

Oracle® General Ledger

Implementation Guide

Release 12.2

Part No. E48747-09

November 2023

Oracle General Ledger Implementation Guide, Release 12.2

Part No. E48747-09

Copyright © 1988, 2023, Oracle and/or its affiliates.

Contributing Author: Stacey Tucker-Blosch

Contributor: Gowri Arur

This software and related documentation are provided under a license agreement containing restrictions on use and disclosure and are protected by intellectual property laws. Except as expressly permitted in your license agreement or allowed by law, you may not use, copy, reproduce, translate, broadcast, modify, license, transmit, distribute, exhibit, perform, publish, or display any part, in any form, or by any means. Reverse engineering, disassembly, or decompilation of this software, unless required by law for interoperability, is prohibited.

The information contained herein is subject to change without notice and is not warranted to be error-free. If you find any errors, please report them to us in writing.

If this is software or related documentation that is delivered to the U.S. Government or anyone licensing it on behalf of the U.S. Government, then the following notice is applicable:

U.S. GOVERNMENT END USERS: Oracle programs, including any operating system, integrated software, any programs installed on the hardware, and/or documentation, delivered to U.S. Government end users are "commercial computer software" pursuant to the applicable Federal Acquisition Regulation and agency-specific supplemental regulations. As such, use, duplication, disclosure, modification, and adaptation of the programs, including any operating system, integrated software, any programs installed on the hardware, and/or documentation, shall be subject to license terms and license restrictions applicable to the programs. No other rights are granted to the U.S. Government.

This software or hardware is developed for general use in a variety of information management applications. It is not developed or intended for use in any inherently dangerous applications, including applications that may create a risk of personal injury. If you use this software or hardware in dangerous applications, then you shall be responsible to take all appropriate fail-safe, backup, redundancy, and other measures to ensure its safe use. Oracle Corporation and its affiliates disclaim any liability for any damages caused by use of this software or hardware in dangerous applications.

Oracle and Java are registered trademarks of Oracle and/or its affiliates. Other names may be trademarks of their respective owners.

Intel and Intel Xeon are trademarks or registered trademarks of Intel Corporation. All SPARC trademarks are used under license and are trademarks or registered trademarks of SPARC International, Inc. AMD, Opteron, the AMD logo, and the AMD Opteron logo are trademarks or registered trademarks of Advanced Micro Devices. UNIX is a registered trademark of The Open Group.

This software or hardware and documentation may provide access to or information about content, products, and services from third parties. Oracle Corporation and its affiliates are not responsible for and expressly disclaim all warranties of any kind with respect to third-party content, products, and services unless otherwise set forth in an applicable agreement between you and Oracle. Oracle Corporation and its affiliates will not be responsible for any loss, costs, or damages incurred due to your access to or use of third-party content, products, or services, except as set forth in an applicable agreement between you and Oracle.

For information about Oracle's commitment to accessibility, visit the Oracle Accessibility Program website at <http://www.oracle.com/pls/topic/lookup?ctx=acc&id=docacc>.

Oracle customers that have purchased support have access to electronic support through My Oracle Support. For information, visit <http://www.oracle.com/pls/topic/lookup?ctx=acc&id=info> or visit <http://www.oracle.com/pls/topic/lookup?ctx=acc&id=trs> if you are hearing impaired.

Contents

Send Us Your Comments

Preface

1 General Ledger Setup

Overview of Setting Up	1-1
Implementation Considerations.....	1-1
Setting Up General Ledger.....	1-4
General Ledger Setup Flowchart.....	1-5
Accounting Setup Manager.....	1-6
Setup Checklist	1-7
General Ledger Setup Steps	1-16
Planning and Installation	1-28
Defining Your Chart of Accounts.....	1-28
The Intercompany Segment and Use of Security Rules.....	1-32
Defining Descriptive Flexfields for General Ledger.....	1-33
Designing Your Accounting Flexfield	1-34
Determining Your Account Needs.....	1-37
Designing Your Account Segments.....	1-39
Defining an Accounting Flexfield Segment for Future Use.....	1-43
Defining Your Account Structure.....	1-44
Permitted Chart of Accounts Changes.....	1-50
Assigning the Management Segment to an Existing Chart of Accounts.....	1-51
Defining Segment Qualifiers.....	1-52
Parent and Child Values and Rollup Groups.....	1-55
Defining Accounts	1-59
Segment Value Inheritance.....	1-61

The Account Hierarchy Manager	1-66
Account Hierarchy Manager Overview.....	1-66
Planning Your Hierarchies.....	1-68
Security.....	1-68
Starting the Account Hierarchy Manager.....	1-69
The Account Hierarchy Manager Interface.....	1-70
Displaying Multiple Hierarchies.....	1-75
The Account Hierarchy Manager Toolbar	1-75
The Account Hierarchy Manager Menu	1-76
Mouse Activated Menus.....	1-77
Adding or Changing Account Hierarchies with the Account Hierarchy Manager	1-79
Adding or Changing Parent Values with the Account Hierarchy Manager.....	1-81
Adding or Changing Child Values with the Account Hierarchy Manager.....	1-84
Adding and Changing Rollup Groups with the Account Hierarchy Manager	1-86
Exporting From the Account Hierarchy Manager.....	1-88
Closing the Account Hierarchy Manager	1-89
Project Tracking in General Ledger	1-89
Maintaining Project Balances.....	1-91
Reporting on Projects in General Ledger	1-92
Mapping Charts of Accounts	1-92
Definition Access Set Security.....	1-94
Selecting Mapping Rules.....	1-94
Rollup Rules.....	1-97
Using Summary Accounts.....	1-100
Period Types	1-101
Calendars	1-102
Defining Calendars.....	1-103
Adding Periods to a Calendar.....	1-104
Changing a Calendar.....	1-107
Defining Transaction Calendars	1-108
Business Day Defaults.....	1-109
Defining Ledgers	1-110
Defining Ledger Sets	1-116
Securing Ledger Sets.....	1-117
Data Access Sets	1-118
Planning Your Data Access Sets.....	1-121
Using Data Access Sets.....	1-123
Data Access Set Examples.....	1-123
Defining Data Access Sets.....	1-125
Definition Access Sets	1-128
Defining Definition Access Sets.....	1-130

Securing Definitions.....	1-135
Modifying Definition Privileges.....	1-137
Setting Up Journal Approval.....	1-137
Setting Up General Ledger.....	1-156
Journal Sources.....	1-156
Journal Categories.....	1-162
Suspense Accounts.....	1-168
Transaction Codes.....	1-169
Setting Up Transaction Codes.....	1-175
Defining Transaction Codes.....	1-176
Planning Your Summary Accounts	1-177
Determining Your Summary Account Needs.....	1-178
Planning the Summary Account Structure	1-179
Planning Parent Values and Rollup Groups	1-183
Planning Summary Account Templates	1-184
Defining Summary Accounts.....	1-186
Entering Summary Account Templates	1-188
Maintaining Summary Accounts.....	1-189
Setting the Summary Account Budgetary Control Options.....	1-190
Defining Statistical Accounts.....	1-192
Defining Statistical Units of Measure	1-193
Document Sequences.....	1-194
Defining Document Sequences.....	1-195
Assigning Document Sequences.....	1-196
Assigning Document Sequences by Ledger and Entry Method.....	1-198
Upgrading Balances to Track Balances Entered in the Ledger Currency.....	1-199
Conflicts with Other Processes and Activities.....	1-202
Entering Employees.....	1-203
Setting Up Automatic Tax Calculation.....	1-203
Setting Up Journal Reconciliation.....	1-210
1. Enable Reconciliation for Account Segment Values.....	1-210
2. Enable Reconciliation for Code Combinations.....	1-211
Defining Financial Schedules	1-212
Storage Parameters for Interim Tables	1-213
Opening and Closing Accounting Periods.....	1-214
Data Access Sets.....	1-215
Open and Close Periods Window.....	1-216
Opening an Encumbrance Year.....	1-218
Open and Close Periods Programs.....	1-219

2 Oracle General Ledger Command Center Setup	
General Ledger Command Center Configuration.....	2-2
Setting Up General Ledger Command Center.....	2-2
Setup and Configuration Steps for General Ledger Command Center.....	2-2
Reviewing Data Access Security Setup for General Ledger Command Center.....	2-2
Profile Options for General Ledger Command Center.....	2-3
Loading General Ledger Data.....	2-5
3 Integrating with Oracle Fusion Applications	
Overview of Oracle Fusion Applications.....	3-1
Overview of Oracle General Ledger and Oracle Fusion Accounting Hub Integration.....	3-1
4 Integrating Hyperion Data Relationship Management (DRM) with Oracle General Ledger	
Overview of Hyperion Data Relationship Management.....	4-1
Explaining DRM Configurations.....	4-2
Configuring Oracle General Ledger.....	4-2
Setting System Profile Values.....	4-2
Populating the Data Relationship Management Password.....	4-6
Loading Values from the Oracle E-Business Suite to DRM.....	4-7
Loading Segment Values and Hierarchies into Oracle General Ledger.....	4-7
Using DRM to Manage Segment Values and Hierarchies for Oracle General Ledger.....	4-8
5 Improving General Ledger Performance	
Improving General Ledger Performance.....	5-1
Running the Maintain Summary Templates Program.....	5-2
Running the Optimizer Program.....	5-2
Setting Profile Options for Concurrent Program Performance.....	5-4
Optimizing Performance by Creating Indices on GL_CODE_COMBINATIONS Table.....	5-5
6 Function Security	
Function Security in General Ledger.....	6-1
7 Business Events	
Business Event System Seed Data for Oracle General Ledger.....	7-1

Index

Send Us Your Comments

Oracle General Ledger Implementation Guide, Release 12.2

Part No. E48747-09

Oracle welcomes customers' comments and suggestions on the quality and usefulness of this document. Your feedback is important, and helps us to best meet your needs as a user of our products. For example:

- Are the implementation steps correct and complete?
- Did you understand the context of the procedures?
- Did you find any errors in the information?
- Does the structure of the information help you with your tasks?
- Do you need different information or graphics? If so, where, and in what format?
- Are the examples correct? Do you need more examples?

If you find any errors or have any other suggestions for improvement, then please tell us your name, the name of the company who has licensed our products, the title and part number of the documentation and the chapter, section, and page number (if available).

Note: Before sending us your comments, you might like to check that you have the latest version of the document and if any concerns are already addressed. To do this, access the new Oracle E-Business Suite Release Online Documentation CD available on My Oracle Support and www.oracle.com. It contains the most current Documentation Library plus all documents revised or released recently.

Send your comments to us using the electronic mail address: appsdoc_us@oracle.com

Please give your name, address, electronic mail address, and telephone number (optional).

If you need assistance with Oracle software, then please contact your support representative or Oracle Support Services.

If you require training or instruction in using Oracle software, then please contact your Oracle local office and inquire about our Oracle University offerings. A list of Oracle offices is available on our Web site at www.oracle.com.

Preface

Intended Audience

Welcome to Release 12.2 of the *Oracle General Ledger Implementation Guide*.

This guide assumes you have a working knowledge of the following:

- The principles and customary practices of your business area.
- Computer desktop application usage and terminology.

If you have never used Oracle E-Business Suite, we suggest you attend one or more of the Oracle E-Business Suite training classes available through Oracle University.

See Related Information Sources on page x for more Oracle E-Business Suite product information.

Documentation Accessibility

For information about Oracle's commitment to accessibility, visit the Oracle Accessibility Program website at <http://www.oracle.com/pls/topic/lookup?ctx=acc&id=docacc>.

Access to Oracle Support

Oracle customers that have purchased support have access to electronic support through My Oracle Support. For information, visit <http://www.oracle.com/pls/topic/lookup?ctx=acc&id=info> or visit <http://www.oracle.com/pls/topic/lookup?ctx=acc&id=trs> if you are hearing impaired.

Structure

- 1 General Ledger Setup
- 2 Oracle General Ledger Command Center Setup

- 3 Integrating with Oracle Fusion Applications**
- 4 Integrating Hyperion Data Relationship Management (DRM) with Oracle General Ledger**
- 5 Improving General Ledger Performance**
- 6 Function Security**
- 7 Business Events**

Related Information Sources

Integration Repository

The Oracle Integration Repository is a compilation of information about the service endpoints exposed by the Oracle E-Business Suite of applications. It provides a complete catalog of Oracle E-Business Suite's business service interfaces. The tool lets users easily discover and deploy the appropriate business service interface for integration with any system, application, or business partner.

The Oracle Integration Repository is shipped as part of the Oracle E-Business Suite. As your instance is patched, the repository is automatically updated with content appropriate for the precise revisions of interfaces in your environment.

Do Not Use Database Tools to Modify Oracle E-Business Suite Data

Oracle **STRONGLY RECOMMENDS** that you never use SQL*Plus, Oracle Data Browser, database triggers, or any other tool to modify Oracle E-Business Suite data unless otherwise instructed.

Oracle provides powerful tools you can use to create, store, change, retrieve, and maintain information in an Oracle database. But if you use Oracle tools such as SQL*Plus to modify Oracle E-Business Suite data, you risk destroying the integrity of your data and you lose the ability to audit changes to your data.

Because Oracle E-Business Suite tables are interrelated, any change you make using an Oracle E-Business Suite form can update many tables at once. But when you modify Oracle E-Business Suite data using anything other than Oracle E-Business Suite, you may change a row in one table without making corresponding changes in related tables. If your tables get out of synchronization with each other, you risk retrieving erroneous information and you risk unpredictable results throughout Oracle E-Business Suite.

When you use Oracle E-Business Suite to modify your data, Oracle E-Business Suite automatically checks that your changes are valid. Oracle E-Business Suite also keeps track of who changes information. If you enter information into database tables using database tools, you may store invalid information. You also lose the ability to track who has changed your information because SQL*Plus and other database tools do not keep a record of changes.

General Ledger Setup

Overview of Setting Up

Consider the guidelines in this chapter as you set up General Ledger for your organization. References in this chapter to other areas of this and other Oracle E-Business Suite User's Guides can enhance your understanding of how setting up General Ledger affects the behavior of specific features and functions.

Implementation Considerations

Oracle Applications is an integrated suite of business applications that connects and automates the entire flow of business processes across both front and back office operations and addresses the needs of a global enterprise. Because Oracle Applications are engineered to work together, you can streamline your setup process by sharing common setup data across applications.

Define Accounting Setups Using Accounting Setup Manager

The Accounting Setup Manager streamlines the implementation of your Oracle Financial Applications by centralizing the setup steps for the following common setup components that are shared across Oracle Financial Applications:

- Legal entities
- Ledgers (primary and secondary ledgers)
- Reporting currencies
- Oracle Subledger Accounting (SLA)
- Intercompany accounts
- Intracompany balancing rules

- Sequencing options

Use the Accounting Setup Manager to define an accounting setup. Each accounting setup defines the accounting context for one or more legal entities or a business need that does not involve legal entities.

If defining an accounting setup for one or more legal entities, the accounting setup includes the legal entities, ledgers, and transaction processing options that control the accounting for the legal entities.

The accounting setup process consists of the following steps:

1. **Create an Accounting Setup Structure:** The accounting setup structure creates the framework of the accounting setup and identifies the legal entities, if any, type of accounting setup, and ledgers.
2. **Complete Accounting Options:** Depending on the type of accounting setup you define, you must complete different accounting options to specify how you want to perform accounting and process transactions. Accounting options include ledger options, reporting currency options, subledger accounting options, intercompany accounts, intracompany balancing rules, and sequencing options.

Note: For accounting setups with multiple legal entities, enabling intracompany balancing enables both intercompany and intracompany balancing for a journal that includes multiple legal entities.

3. **Complete the Accounting Setup:** Completing the accounting setup marks the accounting setup complete and launches the General Ledger Accounting Setup program. This program performs the necessary validations to make the setup components of an accounting setup ready for transaction processing and journal entry.

See: *Oracle Financials Implementation Guide*

Complete General Ledger Setup Steps

To create accounting setups, you must complete the General Ledger prerequisites that are used to create ledgers and other setup components in Accounting Setup Manager.

You need to perform this step once for each ledger you define with differences in charts of accounts, accounting calendars, and currencies.

See: *Setting Up General Ledger*, page 1-4.

Define Legal Entities

If you plan to record accounting transactions for one or more legal entities, you can use Oracle Legal Entity Configurator or the Legal Entities tab in Accounting Setup Manager

to define your legal entities.

Note: The Legal Entity pages of Accounting Setup Manager are the same as the Legal Entity pages in Legal Entity Configurator. The only difference is that you can assign balancing segment values to legal entities using Accounting Setup Manager. It is strongly recommended that you assign specific and unique balancing segment values to your legal entities to help you identify legal entities during transaction processing and reporting and take full advantage of all of the legal entity-related features.

Note: If you plan to use jurisdictions that do not come seeded, you can define your own jurisdictions using Legal Entity Configurator before you define legal entities. A jurisdiction is the intersection of the physical territory and type of legislation within which judicial authority may be exercised. The jurisdiction is used to assign a territory to a legal entity.

Note: In General Ledger, a legal entity set up in the Accounting Setup Manager cannot be associated to an Human Resources (HR) organization. General Ledger views each as separate entities. The HR model does not use this model. To satisfy the HR requirement you can select GRE/LE as the HR organization type.

See: Defining Jurisdictions.

See: Defining Legal Entities.

Define Subledger Accounting Methods

If you plan to use Oracle Subledger Accounting (SLA) to integrate data from Oracle Financial Subledgers and non-Oracle systems with Oracle General Ledger, you can define subledger accounting methods using Oracle Subledger Accounting (SLA).

Oracle Subledger Accounting seeds two subledger accounting methods: Standard Accrual and Standard Cash. If you want to define your own subledger accounting methods, you must define them using Oracle Subledger Accounting.

When you define ledgers in Accounting Setup Manager, you can optionally assign a subledger accounting method to your ledger to use this feature.

You must perform this step for each subledger accounting method.

See: Defining Subledger Accounting Methods.

Setting Up General Ledger

Oracle iSetup

If you are implementing a new instance of the Oracle e-Business Suite and have relatively standard implementation requirements, you can use Oracle iSetup to rapidly configure the following applications:

- Oracle General Ledger
- Oracle Payables
- Oracle Receivables
- Oracle Cash Management
- Oracle Assets
- Oracle Purchasing

Important: In order to use Oracle iSetup, the source, central, and target instances must be the same patch set level. For more information refer to the *Oracle iSetup User Guide*.

Related Product Setup Steps

The following steps may need to be performed to implement Oracle General Ledger. These steps are discussed in detail in the Setting Up sections of other Oracle product user's guides. The following table lists each step with a reference to the various Oracle Application user guides.

Set Up Underlying Oracle Applications Technology

During GL setup, you need to complete several steps related to other products:

- Performing system-wide setup tasks such as configuring concurrent managers and printers
- Managing data security, which includes setting up responsibilities to allow access to a specific set of business data and complete a specific set of transactions, and assigning individual users to one or more of these responsibilities.
- Setting up Oracle Workflow

System Administration Setup Steps

Use the *Oracle E-Business Suite Setup Guide* and *Oracle E-Business Suite Flexfields Guide* for help in completing the following setup steps.

Step	Reference
Set up printers, security, and audit trails. <i>See: Oracle E-Business Suite Setup Guide</i>	Common Applications
Set up accounting and descriptive flexfields. <i>See: Oracle E-Business Suite Flexfields Guide</i>	Common Applications

Oracle Human Resources Setup Steps

Use the Setting Up Oracle Human Resources section in the *Oracle Human Resources User's Guide* for help in completing the following setup steps.

Step	Reference
Define Your Employees <i>See: Enter Person., Oracle Human Resources Management System User's Guide</i>	Common Applications

Note: You can enter employee information in Oracle General Ledger if Oracle Human Resources is not installed. *See: Entering a New Employee, Oracle Human Resources Guide.*

Related Topics

Oracle E-Business Suite Setup Guide

Oracle Workflow Guide

General Ledger Setup Flowchart

While you can set up your Oracle General Ledger application in many different ways, and defer optional set up steps until you are ready to use the corresponding functionality, we recommend you use the order suggested in the following flowchart:

Some of the steps outlined in this flowchart and setup checklist are **Required** and some

are Optional. You need to perform **Optional** steps only if you plan to use the related feature or complete certain business functions.

The following setup steps are a high level overview of the setup steps related to Oracle General Ledger and Accounting Setup Manager. The detailed steps are listed on the following pages.

Oracle General Ledger Setup Steps

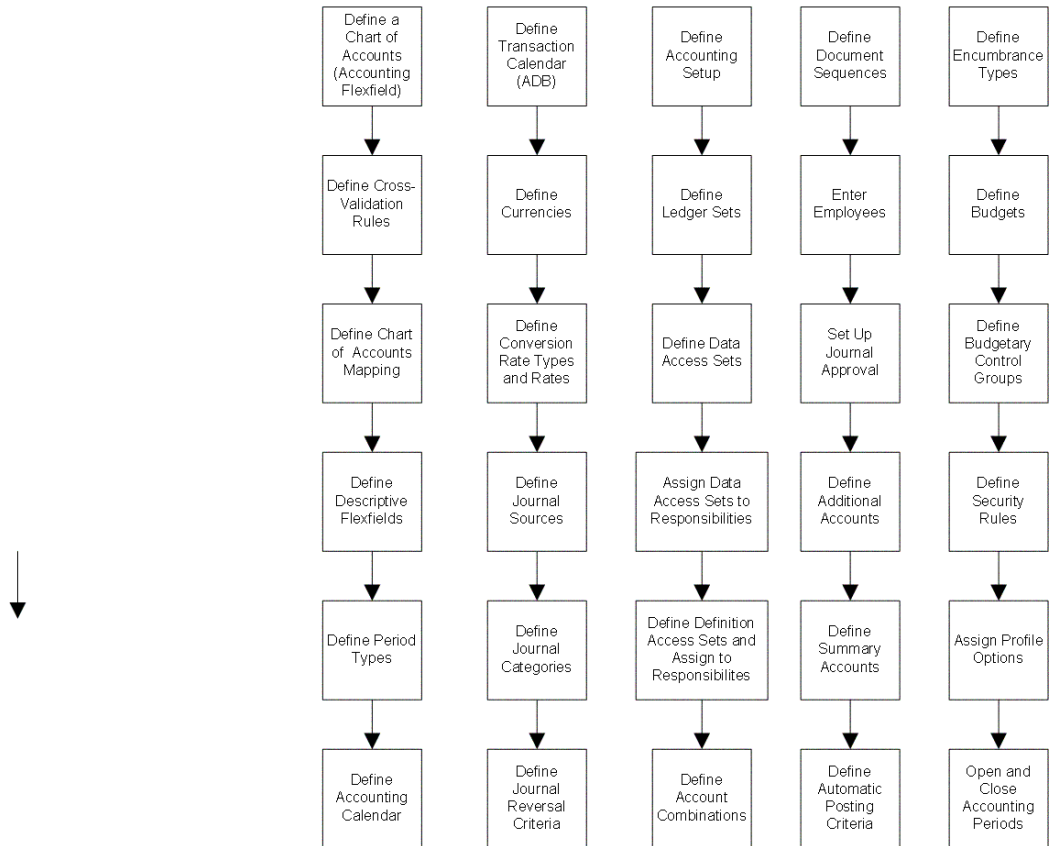

Accounting Setup Manager

To create an accounting setup using Accounting Setup Manager, see *Creating Accounting Setup*.

Note: The steps listed in the Accounting Setup Manager Checklist need to be repeated for each accounting setup you define. Before you can use ledgers in Oracle General Ledger, you must assign them to a complete accounting setup using Accounting Setup Manager

Setup Checklist

The following table provides a more detailed list of Oracle General Ledger setup steps, the Applications area to which each step relates, and whether the step is optional or required. After you log on to Oracle Applications, complete these steps to implement Oracle General Ledger:

Step No.	Required	Step	Reference
Step 1	Required	Define your chart of accounts. See: Defining Your Chart of Accounts, page 1-28.	Common Applications
Step 2	Optional	Define Cross-Validation Rules to prevent certain account combinations from being created.	Common Applications
Step 3	Optional	Define a chart of accounts mapping to map two or more charts of accounts. The chart of accounts mapping is used by Accounting Setup Manager to complete the setup steps for secondary ledgers, and it is used by the Global Consolidation System (GCS) to consolidate data between ledgers.	Common Applications
Step 4	Optional	Define Your Descriptive Flexfields See: Defining Descriptive Flexfields for General Ledger, page 1-33	Common Applications

Step No.	Required	Step	Reference
Step 5	Optional	<p>If you want to use period types not installed with General Ledger, define your accounting period types.</p> <p>See: Period Types, page 1-101</p>	Common Applications
Step 6	Required	<p>Define your accounting calendar. Review the Calendar Validation report to note common setup errors.</p> <p>See: Defining Calendars, page 1-103</p>	Common Applications
Step 7	Optional	<p>If you plan to use average balance processing, define a transaction calendar and valid business days for that calendar.</p> <p>The transaction calendar ensures that journals created in Oracle General Ledger and Oracle Subledger Accounting (SLA), if used, will be posted on valid business days.</p> <p>See: Defining Transaction Calendars, page 1-108</p>	Common Applications

Step No.	Required	Step	Reference
Step 8	Required	<p>Define the currency for your ledger. Also define or enable any reporting currencies you plan to use.</p> <p>See: Oracle General Ledger User's Guide Defining Currencies, <i>Oracle General Ledger User's Guide</i></p>	Common Applications
Step 9	Optional	<p>Define conversion rate types and conversion rates, such as daily rates and historical rates.</p> <p>See: Overview of Multi-Currency Accounting, <i>Oracle General Ledger User's Guide</i></p>	Common Financials
Step 10	Optional	<p>Define additional journal entry sources. If you have enabled average balance processing, specify an Effective Date Rule for each journal source you define.</p> <p>See: Journal Sources, page 1-156</p>	Oracle General Ledger
Step 11	Optional	<p>Define additional journal categories.</p> <p>See: Journal Categories, page 1-162</p>	Oracle General Ledger

Step No.	Required	Step	Reference
Step 12	Optional	Define Journal Reversal criteria. See: Automatic Journal Reversal Overview, <i>Oracle General Ledger User's Guide</i>	Oracle General Ledger

Step No.	Required	Step	Reference
Step 13	Required	<p data-bbox="971 310 1198 594">Define an accounting setup using Accounting Setup Manager to combine legal entities, ledgers, reporting currencies, subledger accounting methods, and other setup information.</p> <p data-bbox="971 625 1198 968">Before you can enter transactions and journal entries to ledgers, you must complete the ledger options for all ledgers assigned to an accounting setup and the accounting setup status must be complete.</p> <p data-bbox="971 999 1198 1146">See: Creating Accounting Setups Oracle Financials Implementation Guide</p> <p data-bbox="971 1178 1198 1556">Define additional journal entry sources and categories. If you have enabled average balance processing, specify an Effective Date Rule for each journal source you define. See: Journal Sources, page 1-156 and Journal Categories, page 1-162</p>	Oracle General Ledger

Step No.	Required	Step	Reference
Step 14	Optional	Define Ledger Sets to group ledgers that share the same chart of accounts and accounting calendar/period type combination to take advantage of processing efficiencies, such as opening and closing periods across ledgers in a ledger set.	Oracle General Ledger
Step 15	Optional	Define data access sets to secure read and write access to ledgers, balancing segment values, and management segment values for one or more ledgers. See: Data Access Sets, page 1-118	Public Sector Applications
Step 16	Required	Assign a ledger to the profile option GL Ledger Name for each Oracle subledger. This profile option controls the ledger chart of accounts that each subledger will use for transaction processing.	Oracle General Ledger

Step No.	Required	Step	Reference
Step 17	Required	<p>Assign a data access set to the profile option GL: Data Access Set for each General Ledger responsibility.</p> <p>See: Data Access Sets, page 1-118</p> <p>See: Setting General Ledger Profile Options, <i>Oracle General Ledger Reference Guide</i></p>	Oracle General Ledger
Step 18	Optional	<p>Define Definition Access Sets and assign them to responsibilities. Once you begin securing your definitions, you can assign the Definition Access Sets assigned to your responsibilities.</p> <p>See: Definition Access Sets, page 1-130</p>	Oracle General Ledger
Step 19	Optional	<p>Define account combinations that can be used for data entry if you did not enable Dynamic Insertion for your chart of accounts structure.</p> <p>See: Defining Accounts, page 1-59</p>	Oracle General Ledger
Step 20	Optional	<p>Define and assign document sequences.</p> <p>See: Defining Document Sequences, page 1-195</p>	Oracle General Ledger

Step No.	Required	Step	Reference
Step 21	Optional	<p>Define Your Employees. (Oracle Human Resources Management System User's Guide)</p> <p>See: Entering a New Employee</p>	Oracle General Ledger
Step 22	Optional	<p>Setup Journal Approval.</p> <p>See: Setting Up Journal Approval, page 1-137</p>	Oracle General Ledger
Step 23	Optional	<p>Define one or more of the following optional accounts:</p> <ol style="list-style-type: none"> 1. Suspense accounts. See: Suspense Accounts, page 1-168 2. Statistical Units of Measure. <p>See: Defining Statistical Units of Measure, page 1-193</p>	Oracle General Ledger
Step 24	Required	<p>Define transaction codes if you use Public Sector General Ledger.</p> <p>See: Setting Up Transaction Codes</p>	Oracle General Ledger

Step No.	Required	Step	Reference
Step 25	Optional	<p>Create summary accounts.</p> <p>See: Defining Summary Accounts, page 1-186</p>	Oracle General Ledger
Step 26	Optional	<p>Set up Automatic Tax Calculation if you do not have Oracle Receivables and Oracle Payables installed.</p> <p>See: Setting Up Automatic Tax Calculation, page 1-203</p>	Oracle General Ledger
Step 27	Optional	<p>Define your automatic posting criteria.</p> <p>See: Posting Journal Batches Automatically, <i>Oracle General Ledger User's Guide</i></p>	Oracle General Ledger
Step 28	Optional	<p>Define encumbrance types.</p> <p>See: Defining Encumbrance Types, <i>Oracle General Ledger User's Guide</i></p>	Oracle General Ledger
Step 29	Optional	<p>Set up Budgets.</p> <p>See: Defining Budgets, <i>Oracle General Ledger User's Guide</i></p>	Oracle General Ledger

Step No.	Required	Step	Reference
Step 30	Optional	If you enabled budgetary control, define one or more budgetary control groups. See: Creating a Budgetary Control Group, <i>Oracle General Ledger User's Guide</i>	
Step 31	Optional	Define Security Rules. See: Defining Security Rules	
Step 32	Required	Set your General Ledger profile options. See: Setting General Ledger Profile Options, <i>Oracle General Ledger Reference Guide</i>	
Step 33	Required	Open an accounting period. See: Opening and Closing Accounting Periods, page 1-214	
Step 34	Optional	Set up the Global Consolidation System (GCS). See: Global Consolidation System, <i>Oracle General Ledger User's Guide</i>	

General Ledger Setup Steps

For each step, we include a Context section that indicates whether you need to repeat the step for each ledger, set of tasks, inventory organization, HR organization, or other

operating unit under Multiple Organizations.

Note: You can use Reporting Currencies to maintain your transactions and account balances in multiple currencies. For setup and user information, see: Reporting Currencies.

1. Define Your Chart of Accounts

Define your chart of accounts using the Flexfield Title, Accounting Flexfield. When you first define your chart of accounts, you must enable Dynamic Insertion. This will enable you to create the necessary account combinations when you define your ledgers using Accounting Setup Manager. After you complete your ledger options, you can optionally disable dynamic insertion for your chart of accounts.

Context: You can define multiple charts of accounts per installation, or you can define a single chart of accounts that is shared by multiple ledgers within a single instance. If you use multiple charts of accounts, it is recommended that you share the same value set for the balancing segment across all charts of accounts. .

See: Defining Your Chart of Accounts, page 1-28. See: Defining Accounts, page 1-59.

See: *Oracle E-Business Suite Flexfields Guide*.

2. Define Your Cross-Validation Rules (optional)

Define cross-validation rules to control the account combinations that can be created during setup and data entry. If you skip this step, no security will be provided to prevent invalid combinations from being created during setup and data entry.

Context: You can define multiple cross-validation rules per chart of accounts. This step is recommended if you have dynamic insertion enabled for your chart of accounts. Perform this step before entering accounts during setup to prevent the creation of invalid combinations that may violate cross-validation rules.

See: Defining Your Cross-Validation Rules.

3. Define Your Chart of Accounts Mapping (optional)

Define a chart of accounts mapping to provide instructions for mapping accounts or entire account segments from one chart of accounts to another for consolidation purposes and secondary ledgers.

For consolidations using the Global Consolidation System, the chart of accounts mapping enables you to transfer consolidation data from your subsidiary ledger to your parent ledger.

For secondary ledgers that use a different chart of accounts from their associated primary ledgers, the chart of accounts mapping enables you to transfer journals and balances from the primary ledger to the secondary ledger. A chart of accounts

mapping is required for all secondary ledgers that use a different chart of accounts from the primary ledger.

Context: Perform this step for each pair of charts of accounts.

See: Mapping Charts of Accounts, page 1-92.

See: Primary to Secondary Ledger Mapping.

4. Define Your Descriptive Flexfields (optional)

Use descriptive flexfields to tailor General Ledger to fit your unique information needs. For example, you may want to collect additional information on budget organizations, such as the manager and the size of the organization. You can even define context-sensitive flexfields that prompt you for additional information based on your previous entries.

There are many other descriptive flexfields in General Ledger. For example, you can set up a descriptive flexfield to store additional information about your transactions.

Context: You need to perform this step only once per installation. You can define descriptive flexfields at any time after General Ledger is set up.

See: Defining Descriptive Flexfields for General Ledger, page 1-33

5. Define Your Accounting Period Types

You can define your own period types to use in addition to the General Ledger standard period types Month, Quarter and Year. You use these period types when you define the accounting calendar for your organization.

Each ledger has an associated period type. When you assign a calendar to a ledger, the ledger only accesses the periods with the appropriate period type. Thus, you can define an accounting calendar with periods of more than one period type. However, each ledger will only use periods of a single period type.

Context: You need to perform this step only once per ledger.

6. Define Your Accounting Calendar

Create a calendar to define an accounting year and the periods it contains. You should set up one year at a time, specifying the types of accounting periods to include in each year. You should define your calendar at least one year before your current fiscal year.

You can define multiple calendars and assign a different calendar to each ledger. For example, you can use a monthly calendar for one ledger, and a quarterly calendar for another.

Note: If you close your balance sheet using the Create Balance Sheet Closing Journals program, you should create an accounting

calendar with two adjusting periods, one on the last day of the year and one on the first day of the year.

Special Note for Average Balance Ledgers: Create an accounting calendar with two adjusting periods that are both at the end of the year. The first adjusting period, representing the last day of the fiscal year, is used to generate the Create Balance Sheet Closing Journals program. The second adjusting period, also representing the last day of the fiscal year, is used to reverse the closing journal. This ensures that the average balance calculation is unaffected in the following year.

Context: You need to perform this step for as many unique accounting calendars you need for your ledgers.

See: Defining Calendars, page 1-103

7. Define Your Transaction Calendar (conditionally required)

Each ledger for which average balance processing is enabled, must be assigned a transaction calendar, which is used to control transaction posting in Oracle General Ledger and Oracle Subledger Accounting. When you define the transaction calendar, you choose which days of the week will be business days. You can also specify other non-business days, such as holidays, by maintaining the transaction calendar.

Context: Perform this step for as many unique transaction calendars you need for your ledgers.

See: Defining Transaction Calendars, page 1-108

8. Define the Currency for Your Ledger

Define the currency for your ledger, or enable one of the predefined ISO (International Standards Organization) currencies. You should also define or enable any additional currencies you plan to use. See: Defining Currencies, *Oracle General Ledger User's Guide*.

Context: You need to perform this step only once per ledger and reporting currency.

See: Defining Currencies, *Oracle General Ledger User's Guide*.

9. Define Conversion Rate Types and Conversion Rates to Support Multiple Currencies (optional).

Conversion Rate Types: Define the conversion rate types you want to use to maintain daily exchange rates and to enter foreign currency journals. General Ledger comes with four predefined conversion rate types: Spot, Corporate, User, and EMU Fixed. See: Defining Conversion Rate Types, *Oracle General Ledger User's*

Guide.

Daily Rates: Enter the daily rates you will need. Typically, you will enter rates to convert foreign currency journal entries into your ledger currency and reporting currencies. See: *Entering Daily Rates, Oracle General Ledger User's Guide.*

Note: If you do not define daily rates, you cannot use daily rates for foreign currency journal entry and Reporting Currencies will not function properly.

Historical Rates: Enter historical rates or amounts to translate selected account balances in accordance with generally accepted accounting standards. General Ledger also uses historical rates and amounts to remeasure selected account balances.

Note: If you do not define Historical Rates for Owners' Equity accounts, General Ledger will use the rate type you specified for the ledger's Period End Rate Type or Period Average Rate Type to create the historical rates.

Context: Perform this step for as many conversion rate types and rates as required. Historical Rates must be created for each ledger.

See: *Overview of Multi-Currency Accounting, Oracle General Ledger User's Guide.*

10. Define Additional Journal Entry Sources (optional)

Define your own journal entry sources in addition to the ones installed with General Ledger to differentiate journal entries and enhance your audit trail. If you have enabled average balance processing, you must also specify an Effective Date Rule for each journal source you define.

Context: Perform this step once per installation.

See: *Journal Sources, page 1-156*

11. Define Additional Journal Entry Categories (optional)

Define your own journal entry categories in addition to the ones installed with General Ledger to differentiate journal entries and enhance your audit trail.

Context: Perform this step once per installation.

See: *Journal Categories, page 1-162*

12. Define Journal Reversal Criteria (optional)

Define journal reversal criteria for journal categories if you want specific journal categories to be reversed using specific rules. Journal reversal criteria lets you specify the default reversal period, date, method, and automatic generation and

posting of reversal journals.

When you create a journal entry you want to automatically reverse, specify a journal category that has been assigned a reversal criterion. Your journal will be reversed, based on the method, period and date criteria you defined for that journal category.

Context: Perform this step once per installation. You can assign the same Journal Reversal Criteria Set to multiple ledgers you define in Accounting Setup Manager. You can complete this step at any time.

See: Automatic Journal Reversal, *Oracle General Ledger User's Guide*.

13. Define Accounting Setups

Define an accounting setup using Accounting Setup Manager to link legal entities to ledgers and other setup components, such as reporting currencies, subledger accounting options, intercompany accounts, intracompany balancing rules, and sequencing options. Each accounting setup must have a status of Complete before you can use its ledgers and setup components for transaction .

If you plan to use average balance processing, you must specifically enable average balance processing, assign a transaction calendar, and define a Net Income account.

If you need to represent your primary ledger transactions in another accounting method, chart of accounts, calendar, currency, and/or ledger processing options, assign secondary ledgers to each accounting setup.

Context: Perform this step once for each accounting setup.

See: Using Accounting Setup Manager.

See: Ledger Options, page 1-110.

See: Reporting Currencies.

14. Define Ledger Sets (optional)

Define Ledger Sets to take advantage of processing efficiencies for General Ledger processes, such as opening and closing General Ledger periods across multiple ledgers in a ledger set, generating MassAllocations across ledgers, or reporting across ledgers.

Context: Perform this step once for each ledger set. Only ledgers that share the same chart of accounts and accounting calendar/period type combination can be grouped in the same ledger set.

See: Defining Ledger Sets, page 1-116.

15. Define Data Access Sets (optional)

Define data access sets to secure read and write access to ledgers, balancing segment values, and management segment values assigned to a ledger. Only one data access set can be assigned to a responsibility.

Note: To streamline the process for users, General Ledger automatically creates a data access set for each ledger and ledger set. The intention is to make data access sets transparent. For example, a user defines a ledger or ledger set and then assigns it to a directly to responsibility. The user doesn't need to be aware that there is such a thing as a data access set. As far as the user can tell, they are assigning the ledger/ledger set directly.

If you skip this step, you will only be able to assign the system generated data access sets to the profile option GL: Data Access Set. The system automatically creates data access sets each time you define a ledger, reporting currency (Journal and Subledger Levels) and ledger set. The system generated data access set provides full read and write access to the ledgers.

Context: Perform this step if you do not want to use the system generated data access sets. Only ledgers, reporting currencies and ledger sets that share the same chart of accounts and accounting calendar/period type combination can be grouped in the same data access set.

See: Data Access Sets, page 1-118.

16. Assign a Ledger to the GL Ledger Name Profile Option

If using Oracle Subledgers whose menus contain General Ledger windows that require data access set information, you must assign the appropriate ledger to the profile option GL Ledger Name for each subledger application or responsibility. This profile option controls the ledger that each subledger will use for transaction processing.

If you skip this step, you will not be able to enter transactions for a ledger in your subledgers. The ledger specified for the GL Ledger Name profile is automatically applied to the GL: Data Access Set profile option, but the GL: Data Access Set profile option can be changed to control the ledgers accessible by General Ledger users.

Context: You need to perform this step only once per installation. This profile option can be set at the application or responsibility level for every Oracle Financial subledger.

17. Set Your GL: Data Access Set Profile Option

To use ledgers in Oracle General Ledger, you must assign a system-generated or user-defined data access set to the GL: Data Access Set profile option.

If using Oracle Subledgers, the ledger you assigned to the GL Ledger Name profile option is automatically assigned to the GL: Data Access Set profile option. You can override the setting if you want to access multiple ledgers in Oracle General Ledger or limit read and write access to ledgers and their balancing segment values and management segment values for General Ledger only. If you choose to override the

GL: Data Access Set profile option, be sure that one of the ledgers in your data access set contains the ledger used by your subledger applications in order to successfully transfer subledger journals to Oracle General Ledger.

If no value is entered for the GL: Data Access Set profile option, you will not be able to enter transactions for a ledger using Oracle General Ledger. This profile option controls which General Ledger responsibilities can access ledgers contained in a data access set.

Context: Perform this step once for each General Ledger responsibility.

See: Data Access Sets, page 1-118.

See: Setting General Ledger Profile Options, *Oracle General Ledger Reference Guide*.

18. Define Definition Access Sets (optional)

Define definition access sets and assign them to responsibilities if you want to secure use, view, and modify access to certain General Ledger definitions, such as MassAllocations and FSG Reports. Once users begin securing their definitions, the Definition Access Sets that have been assigned to their responsibilities will be available.

Context: Perform this step as often as needed.

See Definition Access Sets, page 1-130.

19. Define Account Combinations (conditionally required)

Define account combinations manually in the GL Accounts window if you disabled Dynamic Insertion for your chart of accounts.

Context: You can add or disable multiple account combinations per chart of accounts at any time.

See: Defining Accounts, page 1-59.

20. Define and Assign Document Sequences

Create a document sequence to uniquely number each document generated by an Oracle application. In General Ledger you can use document sequences to number journal entries upon saving a journal, enabling you to account for every journal entry.

Note: Once you define a document sequence, you can change the Effective To date and message notification, as long as the document sequence is not assigned. You cannot change a document sequence that is assigned.

Context: Perform this step once per ledger.

See: Defining Document Sequences, *Oracle Applications User's Guide*.

21. Define Your Employees and Authorization Limits (optional)

Use the Enter Person window in Oracle General Ledger to define employees or contract (contingent) workers. You must enter any employees or contract (contingent) workers, and specify their journal authorization limits in the Journal Authorization Limits window before you can use Journal Approval.

If you previously defined your employees or contract (contingent) workers while setting up a different Oracle Applications product, you only need to set up their journal authorization limits to specify their threshold amounts in Oracle General Ledger.

Context: Perform this step once per installation.

See: *Entering a New Employee, Oracle Applications HRMS User's Guide*

See: *Setting Up Journal Approval, page 1-137.*

22. Set Up Journal Approval (optional)

Set Up Journal Approval for your ledger.

Context: You need to perform this step only once per ledger. You can set up Journal Approval at any time.

See: *Setting Up Journal Approval, page 1-137*

23. Define Additional Accounts (optional)

Suspense Accounts

Create suspense accounts to automatically balance journal entries from particular journal sources and categories. If you skip this step, you will not have unique suspense accounts for different journal sources and categories.

Context: Perform this step once per ledger

See: *Suspense Accounts, page 1-168.*

Statistical Units of Measure (optional)

General Ledger lets you maintain statistical, as well as monetary balances for any account. However, in some cases you may want to set up separate accounts specifically for statistical information. For example, you might want to enter the units sold statistic in your Sales Revenue and Sales Expense accounts, but enter the square feet statistic in only a single account.

Context: Perform this step once per installation.

See: *Defining Statistical Units of Measure, page 1-193.*

24. Define Transaction Codes (Public Sector Installations Only)

If you are a government customer, you can use transaction codes to assign additional debit and credit pairs to a single transaction and have General Ledger create the additional entries automatically.

You can use transaction codes to assist in budget execution or in any situation where you would like to customize the accounting effects of one transaction. When you reference a transaction code on a data entry window, General Ledger automatically generates the additional accounting entries predefined for that transaction code.

Context: Perform this step once.

See Transaction Codes, page 1-169.

25. Create Summary Accounts (optional)

A summary account is an account whose balance is the sum of balances from multiple detail accounts for a ledger. Use summary accounts to perform online summary inquiries, as well as speed the processing of financial reports, MassAllocations, and recurring journal formulas.

Context: Perform this step once per ledger.

See: Defining Summary Accounts, page 1-186.

26. Set Up Automatic Tax Calculation if You Do Not Have Oracle Receivables and Oracle Payables Installed (optional)

Since journal entry taxes are computed similarly to taxes within Payables or Receivables, much of your Payables or Receivables setup is reusable. If you do not use those applications, you can also access the setup forms from within General Ledger.

Other journal entry tax setup information is associated with a particular ledger; therefore, you need to complete this setup for each ledger. Also, if you use multiple organization support in Payables and Receivables, tax information is associated with a specific operating unit, so you need to complete this setup for each operating-unit-specific responsibility.

Context: Perform this step once per ledger.

See: Setting Up Automatic Tax Calculation, page 1-203.

27. Define Your Automatic Posting Criteria (optional)

You can automatically post journal batches that meet specific criteria that you have defined in an AutoPost criteria set. You can define multiple criteria sets that include a range of journal effective dates and multiple AutoPost priorities. AutoPost priorities can be defined for combinations of journal source, journal category, balance type, and period.

Context: Perform this step once per criteria set for your installation.

See: Posting Journal Batches Automatically, *Oracle General Ledger User's Guide*.

28. Define Encumbrance Types (optional)

Define custom encumbrance types in addition to the encumbrance types installed with General Ledger to classify and track your expenditures according to your purchasing approval process.

Context: Perform this step once per installation.

See: *Defining Encumbrance Types, Oracle General Ledger User's Guide*

29. Set Up Budgets (optional)

Use budgets to enter estimated account balances for a specified range of periods. You can use these estimated amounts to compare actual balances with projected results, or to control actual and anticipated expenditures.

Define a budget to represent specific estimated cost and revenue amounts for a range of accounting periods. You can create as many budget versions as you need for a ledger.

Context: You can create one or multiple budgets for a ledger at any time. You can create budget hierarchies by assigning a master budget to lower-level budgets. This enables you to track budgeted amounts against a control budget.

Note: You must complete this step if you want to enable budgetary control.

See: *Defining Budgets, Oracle General Ledger User's Guide*.

30. If You Enabled Budgetary Control, Define One or More Budgetary Control Groups (optional)

You can create a budgetary control group by specifying funds check level (absolute, advisory, or none) by journal entry source and category, together with tolerance percent and tolerance amount, and an override amount allowed for insufficient funds transactions. You must define at least one budgetary control group to assign to a site through a profile option.

Important: You must install General Ledger to use budgetary control, encumbrance accounting, budgetary accounts, and funds checking. Full use of these features also requires installing Purchasing and Payables.

Context: Perform this step once per installation.

See: *Creating a Budgetary Control Group, Oracle General Ledger User's Guide*.

31. Define Security Rules (optional)

Define segment value security rules to restrict user access to certain segment values when entering journals, performing online inquiries, and running FSG and some standard reports. Segment value security rules can work alone or with data access

set security that secures data in ledgers, balancing segment values, or management segment values.

If you skip this step, you will be able to use and view all segment values defined, assuming you have read and write access to those values via your data access set.

Context: You can perform this step at anytime. The same security rules can be applied to multiple Responsibility and Application combinations.

See: Defining Security Rules.

32. Set Your General Ledger Profile Options (optional)

Profile options specify how your Oracle General Ledger application controls access to and processes data. In general, profile options can be set at one or more of the following levels: site, application, responsibility, and user. See: Overview of Setting User Profiles.

Context: You need to perform this step only once per installation.

See: Setting General Ledger Profile Options, *Oracle General Ledger Reference Guide*

See: Overview of User Profiles and Setting User Profile Options.

33. Open Accounting Period

Open and close accounting periods to control journal entry and journal posting, as well as to compute the beginning period balances when opening the first period of a new year.

Context: Perform this step once per ledger.

See: Opening and Closing Accounting Periods, page 1-214

34. Set Up the Global Consolidation System (optional)

Set up the Global Consolidation System (GCS) if you want to consolidate multiple companies using separate ledgers.

If you skip this step, you cannot use the Global Consolidation System to consolidate financial results of multiple companies in your organization to a parent company.

Context: Perform this step once per installation.

See: Global Consolidation System, *Oracle General Ledger User's Guide*.

Related Topics

Project Tracking in General Ledger, page 1-89

Overview of Multi-Currency Accounting, *Oracle General Ledger User's Guide*

Using Budgetary Control and Online Funds Checking, *Oracle General Ledger User's Guide*

Overview of Average Balance Processing, *Oracle General Ledger User's Guide*

Global Consolidation System (GCS), *Oracle General Ledger User's Guide*

Intercompany and Intracompany Balancing

Overview of Flexfield Value Security, *Oracle Applications Flexfields Guide*

Overview of Accounting Setups

Planning and Installation

You need to create and set up one or more ledgers in Accounting Setup Manager. The number of books you set up and the types of ledgers depend on various factors, such as whether you have multiple subsidiaries, if those subsidiaries must adhere to different countries' legal requirements, and if each subsidiary requires their own ledgers or can share the same ledger. If you need to represent your transactions in a different accounting method, chart of accounts, calendar, currency, and/or ledger processing options, a secondary ledger and/or reporting currencies will need to be defined.

Below are detailed instructions for each of the Planning and Installation steps outlined in the overview section. There are references to other sections of this guide for more detailed instructions.

- Defining Your Chart of Accounts, page 1-28
- Defining Descriptive Flexfields for General Ledger, page 1-33

Defining Your Chart of Accounts

Before you begin setting up your chart of accounts, consider your organizational structure and the dimensions of your business. By carefully evaluating your business needs, you can design your chart of accounts to take advantage of General Ledger's flexible tools for recording and reporting your accounting information.

Note: Read about planning and setting up summary accounts before you set up your chart of accounts. See: Planning Your Summary Accounts, page 1-177.

Warning: Oracle General Ledger uses two types of key flexfields for the chart of accounts; the Accounting Flexfield and the GL Ledger Flexfield. The Accounting Flexfield is the primary Accounting Flexfield and should be the only key flexfield used to define and update your chart of accounts. The GL Ledger Flexfield is a copy of the Accounting Flexfield with an added Ledger segment that is created by running the Generate Ledger Flexfield Program. You should never make changes to the GL Ledger Flexfield directly. Doing so can cause data corruption issues. This flexfield is used exclusively for certain General Ledger

features, such as MassAllocations, Recurring Journals and FSG reports.

To set up your chart of accounts:

1. Define value sets. Value sets determine the attributes of your account segments such as the segment length, value alignment, and value security.

Note: Child values should not be assigned to the T Value in a value set.

See: *Defining Value Sets, Oracle Applications Flexfields Guide*

2. Define your account structure using the Accounting Flexfield. Indicate how many separate segments your account will have, and for each segment, enter a name, sequence number, and an associated value set.

Note: Number your segments starting with 1, then 2, 3, 4 and so on.

Warning: Plan your account segment order carefully. Once you freeze your Accounting Flexfield account structure in the Key Flexfield Segments window and begin using account numbers in data entry, you should not modify the flexfield definition. Changing the existing flexfield structure after flexfield data has been created can cause serious data inconsistencies. Modifying your existing structures may also adversely affect the behavior of cross-validation rules and shorthand aliases. For a list of permitted chart of accounts changes, see *Permitted Chart of Accounts Changes*, page 1-50.

- Designate one of your segments as the natural account segment and another as the balancing segment. You can optionally designate a cost center segment, management segment, secondary tracking segment and/or intercompany segment. If you are using Oracle Assets or Oracle Projects, you must specify a cost center segment.
- The optional Secondary Tracking Segment qualifier designates another segment in your chart of accounts in addition to your balancing segment to track Retained Earnings, Cumulative Translation Adjustment, and Unrealized Gains and Losses. This segment can be any segment, except the balancing segment, natural account segment, or intercompany segment. This segment can be the same as your cost center segment. See: *Secondary Tracking Segment, Oracle General Ledger User's Guide*.

- Optionally assign a management segment if you want to secure management values or perform management reporting. The management segment can be any segment, except the balancing segment or natural account segment. Typically, the management segment is a segment that has management responsibility, such as the department, cost center, or line of business. By designating a segment of your chart of accounts to be the management segment, you can secure access to the management segment values with data access sets.

Note: You can assign a management segment to an existing chart of accounts at any time by running two programs in sequence: Prepare Journal Batches for Management Segment Upgrade and Complete Management Segment Upgrade.

- Optionally, assign the intercompany flexfield qualifier to one of the segments in your chart of accounts. You cannot use the primary balancing, cost center, or natural account as the intercompany segment.
- Use dependent account segments when you want a "context-sensitive" segment whose values have different meanings when you combine them with different values of another segment.

Warning: Plan your chart of accounts segments carefully. You cannot make changes to your segments or flexfield qualifiers later. Any changes made to any segment, such as adding one, removing one, changing the associated flexfield qualifier, or changing the associated value set will cause data corruption.

Note: For a list of permitted chart of accounts changes, see Permitted Chart of Accounts Changes, page 1-50.

See: Designing Your Accounting Flexfield, page 1-34

Note: If you plan to use General Ledger for basic project tracking, define a project segment. See: Project Tracking in General Ledger, page 1-89.

3. Define rollup groups to create summary accounts whose summary balances you can review. You assign parent segment values to rollup groups.

See: Defining Rollup Groups, *Oracle Applications Flexfields Guide*

4. Define your account segment values. If you plan on defining summary accounts or

reporting hierarchies, you must define parent values as well as child or detail values.

You can set up hierarchy structures for your segment values. Define parent values that include child values. You can view a segment value's hierarchy structure as well as move the child ranges from one parent value to another.

See: *Defining Segment Values, Oracle Applications Flexfields Guide*

5. Define Security Rules to restrict user access to certain account segment values.

See: *Defining Security Rules, Oracle Applications Flexfields Guide*

6. Define cross-validation rules to control the account combinations that can be created during data entry. For example, you may decide that your sales cost centers, 600 to 699, should only enter amounts to product sales accounts, 4000 to 4999. If you have dynamic insertion enabled, it is recommended that you also define cross-validation rules to provide additional security to prevent invalid combinations from being created during data entry.

Note: Cross-Validation rules only affect new account combinations that are created after you define or enable the rules. If you have existing combinations that violate your rules, your cross-validation rules will not be enforced. You will need to disable all existing combinations that violate your rules before your cross-validation rules can take effect.

See: *Defining Your Cross-Validation Rules, Oracle Applications Flexfields Guide*

7. Define or enable descriptive flexfields.

See: *Defining Descriptive Flexfields for General Ledger, page 1-33*

8. Define account shorthand aliases to speed entry of account segment values. If you enable shorthand alias flexfield entry when you define your account structure, then you can define aliases, or codes, which stand for complete or partial accounts.

See: *Defining Shorthand Aliases, Oracle Applications Flexfields Guide*

9. Define summary accounts to create and maintain summary balances for quick reporting and online inquiry of summarized balances.

See: *Defining Summary Accounts, page 1-186*

10. Create account combinations.

If you allow dynamic insertion, you can create new account combinations automatically as you use them during journal entry. If you do not allow dynamic insertion, define new account combinations manually in the GL Accounts window.

You can define new account combinations or disable existing account combinations at any time.

In the GL Accounts window, check the preserve check box to preserve account combinations against attribute updates when you run the Segment Value Inheritance program.

See: Defining Accounts, page 1-59

Related Topics

Designing Your Accounting Flexfield, page 1-34

Defining Accounts, page 1-59

Permitted Chart of Accounts Changes, page 1-50

Defining Descriptive Flexfields for Oracle General Ledger, page 1-33

Defining Summary Accounts, page 1-186

Defining Value Sets, *Oracle Applications Flexfields Guide*

Defining Key Flexfields, *Oracle Applications Flexfields Guide*

Defining Segment Values, *Oracle Applications Flexfields Guide*

Defining Rollup Groups, *Oracle Applications Flexfields Guide*

Defining Your Cross-Validation Rules, *Oracle Applications Flexfields Guide*

Defining Shorthand Aliases, *Oracle Applications Flexfields Guide*

Overview of Shorthand Flexfield Entry, *Oracle Applications Flexfields Guide*

The Intercompany Segment and Use of Security Rules

Instead of sharing the same value set, use different value sets for the primary balancing segment and the intercompany segment where both value sets have the same values. If the primary balancing segment and intercompany segment share the same value set, the intercompany segment is affected when the segment value security is enabled.

For example, your organization has companies 01, 02, 03, and 04 sharing the same ledger. Current security rules prevent these companies from posting transactions to one another. Instead, the companies must agree on the transactions, then manually enter and post their respective side of the transaction. Should the intercompany segment adopt the same security rules, automatic intercompany balancing would conflict with the security rules.

There are two ways to modify General Ledger to function appropriately with the intercompany segment:

- In the Segments window, disable security for the intercompany segment.
- Create an intercompany segment with an identical value set as the balancing

segment. Establish your own security rules for the intercompany segment value set.

Defining Descriptive Flexfields for General Ledger

Use descriptive flexfields to tailor General Ledger to fit your unique information needs. For example, you may want to collect additional information on budget organizations, such as the manager and the size of the organization. You can even define context-sensitive flexfields that prompt you for additional information based on your previous entries. For example, if you classify the budget organization as a large organization, your descriptive flexfield could ask for the name and telephone number of the controller of the organization.

To define a descriptive flexfield for General Ledger:

1. Define a value set for each of the segments that you want to include. You can use a value set that you included in your account structure.

You can define your descriptive flexfield to have global and context-sensitive segments. Global segments collect the same information all of the time, while context-sensitive segments collect different information depending on the situation.

2. Choose the form and window where you want to enter additional information. General Ledger lets you define a unique descriptive flexfield for virtually any window of any form.
3. Define a list of values or acceptable choices for your descriptive flexfield segments. You can define descriptive flexfield segments that allow any entered values or segments that allow only certain values.

To enable the Journals - Captured Information descriptive flexfield:

The Journals - Captured Information descriptive flexfield is context sensitive, based on the natural account segment value of the account in your journal entry line. Define this descriptive flexfield with the following values:

Field Name	Value
Prompt	Account Number
Value Required	Yes
Default Value	(leave blank)
Override Allowed	No

Field Name	Value
Reference Field	CONTEXT3

Define context field values that match your natural account segment values, and define context-sensitive segments that will capture the desired information based on the natural account segment value you enter in the journal entry line. You can define up to ten segments for each context field value, less any global segments you define.

Related Topics

Entering Journal Lines, *Oracle General Ledger User's Guide*

Planning Your Descriptive Flexfields, *Oracle Applications Flexfields Guide*

Descriptive Flexfield Concepts, *Oracle Applications Flexfields Guide*

Designing Your Accounting Flexfield

Use Accounting Flexfields to design the structure of your General Ledger accounts. By providing flexible account structures, Accounting Flexfields enable you to take advantage of General Ledger flexible tools for recording and reporting accounting information. You can design an account structure that best meets the needs of your organization.

Accounting Flexfields let you:

- Define a flexible account structure that accommodates your current organization, and anticipates the way you will run your organization in the future.
- Define an account structure large enough to reflect the important aspects of your organization, but small enough so that it is manageable and meaningful.
- Define an account structure that accommodates and properly classifies information from your other financial information sources.
- Create an account structure that provides a logical ordering of values by grouping related accounts in the same range of values. Additionally, create an account structure that allows for expansion and development of new categories.

Warning: Plan your Accounting Flexfield structures carefully, including segment information such as segment order and field lengths. Once you define your Accounting Flexfields and enter flexfield values, you cannot change your structures. Attempting to do so may create data inconsistencies that impact the behavior of

your application or require a complex conversion program. Changing your existing structures may also adversely affect the behavior of items that reference your present flexfield structure, such as financial statements, recurring journal entries, allocations, consolidations, cross-validation rules and shorthand aliases.

Warning: Oracle General Ledger has two types of key flexfields for the chart of accounts, the Accounting Flexfield and the General Ledger Flexfield. When defining or making permitted changes to your chart of accounts, always use the Accounting Flexfield. For a list of permitted chart of accounts changes, see Permitted Chart of Accounts Changes, page 1-50.

Major Features

Account Structure

Define the Accounting Flexfield to create accounts that fit the specific needs of your organization. You choose the number of segments, the length of each segment, and the name and order of each segment in your account code structure.

Flexible Organizational Structures

General Ledger lets you quickly reorganize your company or agency by using parent values. Not only can you change reporting structures by assigning a range of child values to a new parent and using that parent in report definitions, but you can also maintain the old structure for comparative purposes by having the same range of child values rollup to two different parents.

For example, if your company reassigns a product to a different division, you can easily move the child values that rollup to the old parent level division to the new parent level division and produce reports for the new division.

Multiple Rollups

You can review your summary accounting information from multiple perspectives.

For example, you may want a summary account that shows the total of all product sales for each division. You can also summarize the same set of detail accounts in a different way and see instead, the total sales of personal computer products across all divisions.

Financial Statement Generator

You can build your custom reports without programming by using your Oracle General Ledger application Financial Statement Generator. You can define reports online with complete control over the rows, columns and contents of your report.

Account Ranges

Throughout General Ledger, you can use ranges to quickly specify a group of accounts. With a well-planned account structure, you can use ranges to group accounts in reports, to specify validation rules and to define summary accounts and reporting hierarchies.

Related Topics

Determining Your Account Needs, page 1-37

Designing Your Account Segments, page 1-39

Defining Your Account Structure, page 1-44

Defining Segment Qualifiers, page 1-52

Key Flexfields in Oracle Applications, *Oracle Applications Flexfields Guide*

Determining Your Account Needs

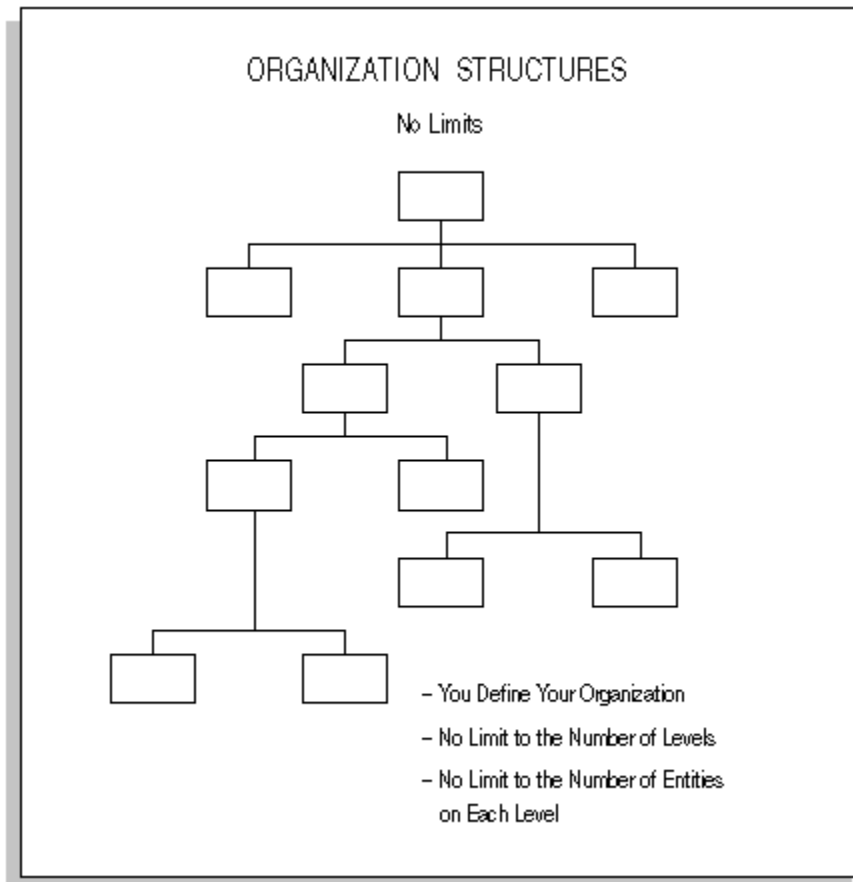

To make effective decisions about your account structure, consider the structure and dimensions of your organization. Remember as you analyze your account needs, there is no limit to the number of levels you can define in your organization. There is also no limit to the number of entries at each level.

To determine the account structure that best suits your organization:

1. Examine your organization structure to identify how you measure performance and profitability.

You may even want multiple organizational structures to allow views of the organization from multiple perspectives. For example, if you have both regional and country managers, you can set up one segment which is based on "Location". You can use summary accounts to roll up managers from each location to their respective country managers.

2. Visualize each segment of your account as a unit dimension of your business. Combine units that are based on similar dimensions to avoid using multiple

segments that measure the same dimension.

3. Identify the functions, products, programs, funding sources, regions, or any other business dimensions you want to track.
4. Determine how you want to model your legal entities. It is highly recommended that you model your legal entities using the balancing segment so that you can take optimal advantage of Oracle's product features related to legal entity accounting. You should assign specific balancing segment values to each legal entity to enable you to easily identify transactions and balances for a specific legal entity. It also allows you to use certain legal entity accounting features, such as Intercompany Accounting.
5. Determine your reporting needs. Consider the following questions as you begin defining your account structure:
 - What information will better help you manage your organization?
 - What different ways can you look at your operations?
 - What kinds of reports do managers ask for? Product or service managers may want to see a gross margin report for each of their products or services. Managers responsible for a particular functional area, such as the Vice President of Research and Development, might want to see an employee expense report for the entire division.
 - What reports are currently difficult to prepare?
 - What reports do you need, that are provided by other financial information systems such as a revenue tracking system?
 - What statistical reporting, such as headcount by division, or unit sales by product, do you want to perform?
 - Do you need to perform project reporting?
 - At what levels of detail do you produce reports?

Related Topics

Overview of Accounting Setups

Defining Your Chart of Accounts, page 1-28

Designing Your Account Segments, page 1-39

Defining Accounts, page 1-59

Planning Your Summary Accounts, page 1-177

Designing Your Accounting Flexfield, page 1-34

Designing Your Account Segments, page 1-39

Defining Your Account Structure, page 1-44

Key Flexfields in Oracle Applications, *Oracle Applications Flexfields Guide*

Designing Your Account Segments

The account structure helps you categorize your accounting information as you record it. You create an account structure by defining Accounting Flexfield segments that comprise the account. You should design your accounts to determine the number and characteristics of the segments you need.

Below are some common entities that many organization define with separate account segments. You can also identify one of these as a secondary tracking segment or management segment, unless you have already designated it as the primary balancing, intercompany, and natural account segments.

- **Legal Entity:** A segment that identifies the legal entity for your operations. If your company uses more than one legal entity and you want the ability to identify legal entities during transaction processing, you should designate the balancing segment of your chart of accounts as the legal entity or company segment.
- **Company:** A segment that indicates legal entities for commercial, for-profit organizations.
- **Fund:** A segment that indicates a fiscal and accounting entity with a self-balancing set of accounts for governmental or not-for-profit organizations.
- **Cost Center or Department:** A segment that indicates functional areas of your business or agency, such as Accounting, Facilities, Shipping, and so on.
- **Account:** A segment that indicates your "natural" account, such as Cash, Accounts Payable, or Salary Expense.
- **Product:** A segment that indicates products, such as disk drives, printer cables or magnetic tapes manufactured by a commercial, for-profit organization.
- **Program:** A segment that indicates programs, such as, for a university, scholarship program, endowment program, or annual giving program.
- **Project:** A segment that indicates projects such as work orders, contracts, grants, or other entities for which you want to track revenues and expenses.
- **District:** A segment that indicates geographical locations, such as Northern California, Central Florida or Western New York.

- **Distribution Channel:** A segment that indicates the method by which your product reaches your customer, such as Wholesale, Retail, OEM, and so on.
- **Intercompany:** A segment that indicates intercompany entities. This segment usually mirrors your company or legal entity segment.

To determine your account segment needs:

1. Determine the segment that captures the natural account, such as assets, liabilities, expenses, and so on.
2. Define a separate Accounting Flexfield segment for each dimension of your organization on which you want to report, such as regions, products, services, programs, and projects.

For example, you may want to record and report on expenses by project. To do this, your account must categorize expenses by project. Define your account to include a "Project" segment. By doing this, you automatically categorize all your accounting information by project as you enter it, and you can easily report on project information.

3. Group similar business dimensions into one segment. This allows a more simplified and flexible account structure

For example, you only need one segment to record and report on both districts and regions, as illustrated below. Because regions are simply groups of districts, you can easily create regions within your district segment by defining a parent for each region with the relevant districts as children. Use these parents when defining summary accounts to maintain account balances and reporting hierarchies to perform regional reporting.

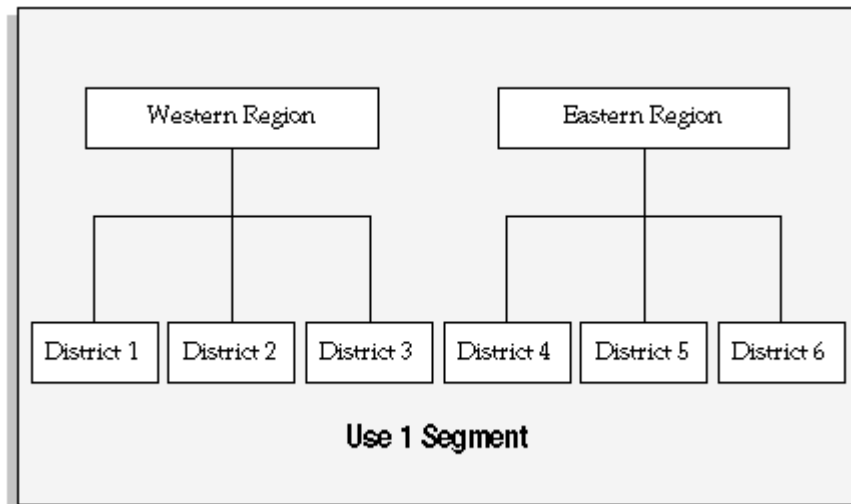

For a text description of this figure, see Text Description of Use 1 Segment, *Oracle*

General Ledger Online Help

This method accommodates reorganizations. Using the previous example, if you want to move district 4 into the Western region, you simply redefine your parents so that district 4 rolls up into the Western region. You can even define new parents for your new organizational structure and retain your old organizational structure for comparative purposes.

4. Consider information you track in other accounting information systems. You may not need to capture certain organizational dimensions if another system already records and reports on this information.

For example, if you need to report on sales by product and your sales tracking system already provides this information, General Ledger account structure does not need to categorize information by product. If you are a government or not-for-profit agency using a labor costing system which captures work breakdown structure for reimbursable billing, you may not need to capture this in your account structure.

5. Identify segments that you might need in the future. Consider future expansion and possible changes in your organization and reporting needs. For example, you may not need a region segment now, but eventually you plan to expand your organization to cover multiple regions. See: *Defining an Accounting Flexfield Segment for Future Use*, page 1-43.

Remember, once you define your account structure and begin using it, you cannot modify it. Try to build flexibility for future needs into your account structure during setup.

6. Determine the length of each segment. Consider the structure of values you plan to maintain within the segment. For example, you might use a 3 character segment to capture project information, and classify your projects so that all Administrative projects are in the 100 to 199 range, all the Facilities projects are in the 200 to 299 range, and so on. If you develop more than 10 classifications of projects, you would run out of values within this segment. You might want to add an extra character to the size of each segment to anticipate future needs.
7. To perform multi-company or fund accounting within a ledger, choose a primary balancing segment. You must define one and only one primary balancing segment in your account. General Ledger automatically balances all journal entries for each value of this balancing segment and performs any necessary intercompany or interfund posting to the intercompany or interfund account you specify when you define your ledger.

If you generate many intercompany transactions, you can use an intercompany segment to augment resulting intercompany payables and receivables.

8. Identify a secondary tracking segment in your chart of accounts. General Ledger will track retained earnings, cumulative translation adjustments, and revaluation

gains/losses by both the primary balancing segment and the secondary segment to provide you with more accounting detail. The secondary tracking segment cannot be the primary balancing segment, intercompany segment, or natural account segment. Assign the Secondary Tracking Segment Qualifier to your secondary tracking segment.

9. If you want to perform management reporting and secure read and write access to segment values for the management segment, designate one of your segments to be the management segment. This segment can be any segment, except the balancing segment, natural account segment, or intercompany segment. Typically, you should choose a segment that has management responsibility, such as the department, cost center, or line of business.
10. If you plan to maintain and consolidate multiple ledgers, think of common elements among your separate account structures. Consider which segments can share value sets, or where opportunities for rolling up segments from a subsidiary ledger into a parent ledger exist.
11. Plan your value sets. To reduce maintenance and to maintain consistency between ledgers, you can reuse value sets when defining multiple charts of accounts. Using the same value sets allow two different ledgers to reference the same segment values and descriptions for a specified segment. For example, the values in your natural account segment, such as Cash, Accounts Payable, and so on, may be equally applicable to each of your ledgers. Ideally, when you set up a new ledger you should consider how you will map your new Accounting Flexfield segments for consolidation. When a common natural account segment is used between ledgers, it is easier to map account balances from your subsidiary ledgers to a consolidating entity.

If you have multiple legal entities or companies that use different charts of accounts and you have designated the balancing segment as the legal entity or company segment, you should share the same value set for the balancing segment across all charts of accounts. This enables you to assign unique balancing segment values for each legal entity that is consistent across charts of accounts. This is very beneficial in enabling you to easily identify transactions per legal entity, and it allows you to take full advantage of the legal entity accounting features available, such as Intercompany Accounting.

Related Topics

- Defining Your Chart of Accounts, page 1-28
- Overview of Accounting Setups
- Defining Your Account Structure, page 1-44
- Defining Accounts, page 1-59
- Planning Your Summary Accounts, page 1-177

Designing Your Accounting Flexfield, page 1-34

Determining Your Account Needs, page 1-37

Defining Your Account Structure, page 1-44

Defining Segment Qualifiers, page 1-52

Key Flexfields in Oracle Applications, *Oracle Applications Flexfields Guide*

Defining an Accounting Flexfield Segment for Future Use

When you define your segments, you can define additional segments for future use. This provides greater flexibility if you later decide you need to track your transactions by an additional segment. Otherwise, once you have defined your segments, you would need to create a ledger to add additional segments because once you begin using your chart of accounts, you cannot make any changes, such as adding segments, changing the length of your segments, or changing the assigned flexfield qualifier.

To define a future use segment:

1. Navigate to the Key Flexfield Segments window.
2. In the Application field, select Oracle General Ledger and Accounting Flexfield as the Flexfield Title from your list of values.

Warning: Oracle General Ledger has two types of key flexfields for the chart of accounts: the Accounting Flexfield and the GL Ledger Flexfield. When making any changes to your chart of accounts, always use the Accounting Flexfield.

3. Place your cursor on the desired Accounting Structure and choose the Segments button.
4. Define your future use segment.
5. Verify the Displayed and Enabled boxes have been checked.
6. Choose the Open button.
7. In the validation region of the window, verify that the Required check box has also been enabled.
8. For zeros to default for the segment value during transaction entry, enter the correct number of zeros for that segment in the Default Value field. Make sure you also define the default value in the Segment Values window for this segment.
9. Save your changes.

Note: The future use segment(s) must be displayed and enabled when you define them.

Defining Your Account Structure

Follow these guidelines, *in addition* to generic flexfield definition instructions, when defining your Accounting Flexfield structure.

Note: The Accounting Flexfield has several special requirements and limitations for its definition. Follow these recommendations carefully, since an incorrectly-defined Accounting Flexfield will adversely affect your chart of accounts, and application features such as Mass Allocations.

To define your account structure:

1. Define your Accounting Flexfield value sets using the Define Value Set form. General Ledger does not support the use of predefined value sets with the Accounting Flexfield.
 - You must specify a format type of Char for each segment value. The Accounting Flexfield supports only the Char format type because the alpha character T is used by Summary Template values and dependent segments. If you want to limit your segment values to numbers only, choose the Char format type, then enter only numeric values for your segment values. You should not select the Numbers Only check box for the Accounting Flexfield.

Note: By defining alphanumeric segment values instead of all numbers, you have more flexibility when designing segment value hierarchies. For example, you can use numbers for child segment values and characters for parent segment values. This allows you to quickly distinguish between child and parent segment values.
 - We recommend that you set Right-justify Zero-fill Numbers to Yes for value sets you use with the Accounting Flexfield.
 - Value sets for the Accounting Flexfield must be independent, table, or dependent-type value sets. Do not use value sets with a validation type of None, Pair, or Special for the Accounting Flexfield.
 - Do not specify a hidden ID column for any value set used with the Accounting Flexfield.

- You should not use a WHERE clause and/or ORDER BY clause for a table validated value set you intend to use with the Accounting Flexfield.
 - We recommend that you allow parent values for segments in your Accounting Flexfield. Parent values are used to create summary accounts and define security rules. Using parent and child values increases the productivity of General Ledger.
 - You can define three types of security for value sets.
 - No Security - All security is disabled for your value set.
 - Hierarchical Security - Any security rule defined for a parent value also applies to its child values.
 - Non-Hierarchical Security - Any security rule defined for a parent value does not apply to its child values.
2. Enable the Allow Dynamic Inserts option for each chart of accounts until you have created an accounting setup using Accounting Setup Manager and assigned a data access set to the GL: Data Access Set profile option. Keep this option enabled if you want to allow the automatic creation of new accounts as you enter them in transactions. If you disable this option, you must define all accounts manually in the GL Accounts window before entering transactions.
- Tip:** Enable Dynamic Insertion for new charts of accounts to allow you to perform your setup, such as assigning a retained earnings account to your ledger in Accounting Setup Manager. After you have completed your accounting setup and have assigned a data access set to the GL: Data Access Set profile option, you can disable Dynamic Insertion for the chart of accounts for transaction processing purposes.
- Important:** If you are defining an Accounting Flexfield for Oracle Projects, you must define your segments with the Allow Dynamic Inserts option set to Yes. Refer to the *Oracle Projects User's Guide* for further suggestions on using the Accounting Flexfield with Oracle Projects.
3. Define your Accounting Flexfield segments. You can define up to 30 segments for your account structure. You must define at least two segments for your account structure, one for the balancing segment and one for the natural account segment (the two required flexfield qualifiers).

- When specifying the column you want to use for your Accounting Flexfield segment, do not use any columns other than those named SEGMENT1 through SEGMENT30. Since the names of these columns are embedded in the Oracle Applications products, using other columns may adversely affect your application features such as summarization.
 - Enter the segment number for this segment. The Accounting Flexfield requires consecutive segment numbers beginning with 1 (such as 1, 2, 3, ...).
 - Only Oracle General Ledger applications use the Indexed check box for the Optimization feature. Mark this option if you want the database column that stores this key segment in the combinations table to have a single-column index. You should create indexes for segments you expect to have many distinct values (instead of just a few distinct values).
 - You *must* enter a value set in the Value Set field for each segment of the Accounting Flexfield. Value sets for the Accounting Flexfield must be independent, table, or dependent-type value sets. Do not use value sets with a validation type of None for the Accounting Flexfield.
 - We recommend that you set the Description Size for each of your Accounting Flexfield segments to 30 or less so that your flexfield pop-up window does not scroll horizontally.
 - You *must* check the Display check box for each segment. The Accounting Flexfield requires that all segments be displayed. Hiding segments will adversely affect your application features, such as MassAllocations.
 - You *must* check the Required check box for each segment.
 - When defining a segment for future use, you must adhere to all the rules listed above. It is recommended you define a default value for the segment, such as zeros to ease data entry. See: Defining an Accounting Flexfield Segment for Future Use, page 1-43.
4. Define your flexfield qualifiers for your Accounting Flexfield. Oracle Applications use flexfield qualifiers to identify certain segments in your Accounting Flexfield. You specify your flexfield qualifier values in the Qualifiers region of the Define Key Flexfield Segments form.
 5. Define the natural account segment. A natural account segment contains values representing account types, such as cash, accounts receivable, product revenue and salary expense. In the Flexfield Qualifiers window, select the Enabled check box for the Natural Account Segment to indicate that the segment you are defining is your natural account segment. You can define only one natural account segment in your account.

6. Define the primary balancing segment. General Ledger uses your primary balancing segment to ensure that all journals balance for each value of your primary balancing segment. General Ledger also uses your primary balancing segment to ensure that entries that impact more than one balancing segment use the appropriate intercompany or intracompany balancing.

Indicate whether the segment you are defining is a primary balancing segment. You can define only one primary balancing segment for an account. The segment you use as a primary balancing segment *must* be an independent segment (it cannot use a dependent value set). Most users of General Ledger designate company/legal entity or fund as their primary balancing segment. If using multiple charts of accounts, you should share the same balancing segment across all charts of accounts.

7. Define the Cost Center segment. Cost centers indicate functional areas of your organization, such as Accounting, Facilities, Shipping, and so on. In the Flexfield Qualifiers window, select the Enabled check box to indicate that the segment you are defining is a Cost Center segment.

Oracle Assets and Oracle Projects require you to qualify a segment as cost center in your account.

8. (Optional) Define a management segment if you want to perform management reporting and secure read and write access to segment values for the management segment. This segment can be any segment, except the balancing segment, natural account segment, or intercompany segment.
9. Identify a secondary tracking segment in your chart of accounts and assign the Secondary Tracking Segment qualifier to it. General Ledger tracks retained earnings, cumulative translation adjustments, and revaluation gains/losses by both the balancing segment and the secondary tracking segment to provide you with more accounting detail. The secondary tracking segment cannot be the same segment as the balancing segment, intercompany segment, or natural account segment. See: Secondary Tracking Segment, *Oracle General Ledger User's Guide*.
10. (Optional) Define the intercompany segment. General Ledger automatically uses the intercompany segment in account code combinations to track intercompany transactions within a single ledger and among multiple ledgers. The intercompany segment has the same value set as the balancing segment.
11. Define dependent segments to create context-sensitive segments. Context-sensitive segment values can have one meaning when combined with a particular independent segment value, and have a different meaning when combined with a different segment value.

You can define more than one dependent segment for an independent segment. You can also define more than one independent segment to have different dependent segments. You cannot, however, define a dependent segment for any

segment with validation type other than Independent nor have multiple levels of dependency for the same segment.

12. Define your Accounting Flexfield segment values. When specifying a parent value, be sure to mark the Parent check box and enter the rollup group level information and hierarchy details. Be sure you do not assign overlapping ranges of child values to the same parent value. For multi-level hierarchies, be sure that grandparents do not share the same child ranges as their lower level parent values. This causes looping and will affect your summary accounts.

You use rollup groups to create summary accounts. Decide your segment hierarchy before you create parent and child segment values.

13. Enter Segment Qualifiers. Segment qualifiers hold extra information about individual segments such as if the account is an asset, liability, or expense, if you can post to the account, and more.
14. Freeze and compile your account structure in the Key Flexfield Segments form when you are ready to begin using it. You must recompile your flexfield *every time* you make changes to your structure and segments, including enabling or disabling cross-validation rules and enabling or disabling shorthand entries using the Shorthand Aliases window.

You will see your flexfield changes immediately after you freeze and recompile your flexfield. Other users will see the changes after they change responsibilities or exit the application and log back in.

Warning: Plan your key flexfield structures carefully. Once you freeze your structure and begin using it, you should not modify your structure. Attempting to do so may create data inconsistencies that can seriously impact your application or require a complex conversion program.

15. After you freeze and compile your Accounting Flexfield, you should submit the Generate Ledger Flexfield program from the Requests window. This program dynamically creates the GL Ledger Flexfield. This flexfield is a copy of the Accounting Flexfield with an added Ledger segment. This flexfield is used exclusively by General Ledger features, such as MassAllocations, Recurring Journals and FSG reports that use the Ledger segment.

Warning: You should never use the GL Ledger Flexfield to modify your chart of accounts structure or segment values. You should only use the Accounting Flexfield.

Note: If one or more segments in your Accounting Flexfield use

table validated value sets, you must run the following programs after you freeze and compile your Accounting Flexfield:

- Setup Flattening Program for Table Validated Value Sets: This program needs to be submitted for each table-validated value set in your Accounting Flexfield.
 - Generate Ledger Flexfield: This program needs to be submitted once for each Accounting Flexfield.
16. Define cross-validation rules to control the combinations of values you use to create accounts. Refer to the Designing Your Cross-Validation Rules essay for suggestions on designing your Accounting Flexfield cross-validation rules.
17. Define Flexfield security rules for a responsibility to restrict access to specific segment values or ranges of segment values. Security rules can be applied to hierarchies. Security rules defined for a parent in a hierarchy can extend to all its children.

Security rules restrict access to specific segment values or ranges of segment values:

- When you enter data in General Ledger windows. For example, you cannot enter an account code combination in the Enter Journals window that contains a restricted segment value.
- When you perform online inquiries
- When you run FSG reports
- When you run Standard Reports for Account Analysis, Journals, General Ledger, and Trial Balance.

Note: Programs, such as the subledger transfer programs to General Ledger, Journal Import, or Posting program, do not enforce segment value security rules.

Related Topics

Defining Segment Qualifiers, page 1-52

Defining Accounts, page 1-59

Defining Summary Accounts, page 1-186

Designing Your Accounting Flexfield, page 1-34

Determining Your Account Needs, page 1-37

Designing Your Account Segments, page 1-39

Defining Value Sets, *Oracle Applications Flexfields Guide*

Defining Key Flexfield Segments, *Oracle Applications Flexfields Guide*

Defining Security Rules, *Oracle Applications Flexfields Guide*

Cross-Validation Rules, *Oracle Applications Flexfields Guide*

Permitted Chart of Accounts Changes

After you have used your chart of accounts for transaction processing, you can make changes to certain options. Most of these changes can be made from the Key Flexfield Segments form. Other changes, such as enabling the management segment, can only be made by running two programs in sequence: Prepare Journal Batches for Management Segment Upgrade and Complete Management Segment Upgrade. See Assigning the Management Segment to an Existing Chart of Accounts, page 1-51.

The following changes are permitted from the Key Flexfield Segments window. Before you can make these changes, you must unfreeze your chart of accounts structure.

- **Cross-Validate Segments:** You can enable or disable this option at anytime in the Key Flexfield Segments window.
- **Freeze Rollup Groups:** You can enable or disable this option at anytime in the Key Flexfield Segments window.
- **Allow Dynamic Inserts:** You can enable or disable this option at anytime in the Key Flexfield Segments window.
- **Window Prompt label:** You can change the segment label displayed for each segment in the Segments Summary window.
- **Default Value:** You can change or remove the default value specified for Segments in the Segments window.
- **Security Enabled:** You can enable security for a segment in the Segments window.
- **List of Values Prompt and Window Prompt:** You can change the prompt for the List of Values and window for each segment in the Segments window.

Note: After making the permitted changes, you must save your changes, then freeze and compile your chart of accounts.

Warning: When defining or making the permitted changes to your chart of accounts, always use the Accounting Flexfield. Any changes made to the GL Ledger Flexfield could cause data corruption issues.

Assigning the Management Segment to an Existing Chart of Accounts

The only flexfield qualifier that can be enabled for an existing chart of accounts is the management segment. The management segment can be any segment except the balancing segment, natural account segment, or intercompany segment.

Note: You should never use the Flexfield Qualifiers window to enable the management segment for an existing chart of accounts that has been assigned to a ledger. Doing so could cause data corruption issues.

To enable the management segment for an existing chart of accounts, you must run the following concurrent programs in the following order:

1. **Prepare Journal Batches for Management Segment Upgrade:** When you run this program, you select a chart of accounts and designate a segment to be the management segment. This program begins preparing the chart of accounts to assign the management segment. This program should not be run when users are entering journals or updating balances, such as posting journals.

This program automatically launches the second program, Process Posted Journal Batches for Management Segment Upgrade. This program selects all posted journal batches that exist for all ledgers that use the chart of accounts and prepares them to be upgraded with the new management segment. This is a longer running program that can be run at the same time users are entering and posting journals. The only programs that are incompatible with this program are the archive and purge programs in General Ledger. You can stop and restart this program at anytime.

To restart the program, you must re-run the Prepare Journal Batches for Management Segment Upgrade program. Each time you resubmit the program, the program automatically submits the second program and continues processing the posted journal batches from where it left off when you last cancelled the program.

2. **Complete Management Segment Upgrade:** This program completes the management segment upgrade by processing any remaining journal batches, both posted and unposted, that were not processed from the first two programs and assigns the management segment qualifier to the chart of accounts. This program should not be run when users are entering or posting journals.

Conflicts with Other Processes and Activities

You should only run the first and last programs, the Prepare Journal Batches for Management Segment Upgrade and the Complete Management Segment Upgrade programs, when no conflicting activity is taking place for all ledgers that use the chart of accounts. The following categories of activities conflict with these programs:

- **Journal Creation:** includes entering manual or budgetary control journals, importing journals, running revaluation, MassAllocations, recurring formulas, and

eliminations.

- **Balance Processing:** includes posting, archiving, and purging.

All concurrent processes and online activity that fall into the preceding categories should be completed before you submit both programs.

Tip: Consider excluding the programs from the standard concurrent manager. Instead, assign the program to a special concurrent manager queue that becomes active only at specified times.

To enable the management segment for an existing chart of accounts:

1. Navigate to the Submit Requests window.
2. Select the concurrent program, Prepare Journal Batches for Management Segment Upgrade
3. In the Parameters window, choose a chart of accounts and a segment to be the management segment. You can choose any segment except the balancing segment or natural account segment.

Note: Choose your management segment carefully. Once you submit the program, you cannot change your selection later.

4. Submit the request.
5. Once the request completes, a second program called Process Posted Journal Batches for Management Segment Upgrade is launched automatically.
6. After the second program completes, you must submit the last program named Program – Complete Management Segment Upgrade.

After all programs have completed, your chart of accounts has the management segment assigned. You can query your chart of accounts structure in the Key Flexfield Segments window to see the changes.

Defining Segment Qualifiers

When you define a segment value for your natural account segment in the Segment Values window, you must also assign qualifiers which determine the account type (asset, liability, expense, revenue, or equity), whether budgeting is allowed, whether posting is allowed and other information specific to the segment value. For segments other than the natural account segment, you must specify if budgeting or posting are allowed for each value.

When you change the Budget Entry or Posting Allowed qualifiers for segment values that you already defined, you should also make a corresponding change to all accounts that include the value in the account code combination.

You can run the Segment Value Inheritance program to propagate these changes to all accounts that contain the changed segment value instead of changing all affected account code combinations individually in the GL Accounts window. See Segment Value Inheritance, page 1-61.

Note: Segment qualifiers can be defined for other Oracle Applications. These are listed in each Oracle E-Business Suite User's Guide. Additional segment qualifiers can be defined for use by your custom programs.

You can define the following segment qualifiers for your Accounting Flexfield:

- **Account Type:** Defines the account type for the natural account segment value. You can enter only valid account types.
- **Budget Entry Allowed:** Indicates whether General Ledger should allow detailed budgeting to accounts with this segment value.
- **Posting Allowed:** Indicates whether General Ledger should allow detailed posting to Accounting Flexfields with this segment value.
- **Reconciliation Flag:** Indicates whether General Ledger should allow reconciliation for natural accounts that should balance to zero. You can enable or disable reconciliation for an account segment value or for specific account code combinations.
- **Other Segment Qualifiers:** You can define additional segment qualifiers that are used by other Oracle Applications and your custom programs.

To set the Account Type segment qualifier:

Enter a valid account type for this segment qualifier. This segment qualifier requires a value for the natural account segment only. Account code combinations have the same account type as the natural account segment value they include.

The default value for this field is Expense. Accept this value or change it to one of the other valid account types. Enter the type of your proprietary account (Asset, Liability, Owners' Equity, Revenue or Expense) or the type of your budgetary account (Budgetary Dr or Budgetary Cr) your segment value represents. Choose any proprietary balance sheet account type if you are defining a statistical account segment value. If you choose a proprietary income statement account type for a statistical account segment value, your statistical balance will zero-out at the end of the fiscal year.

If you assigned the wrong account type to your account, see Correcting Misclassified

To set the Budget Entry Allowed segment qualifier:

Enter Yes for Allow Budgeting Entry to perform detailed budgeting for accounts with this segment value. If you do not allow budgeting for a segment value, you cannot assign accounts with this segment value to budget organizations, and you cannot define budget formulas for those accounts.

If you are defining a parent segment value, you must enter No. You cannot enter budget amounts to a segment value that is a parent of other detail segment values where detail budgeting is already allowed.

To set the Posting Allowed segment qualifier:

Enter Yes for Allow Posting to allow detailed posting to accounts with this segment value. If you do not allow posting for a segment value, you cannot use accounts with this segment value when you enter journals, and you cannot use the accounts in recurring journals.

If you are defining a parent segment value by marking the Parent check box, enter No to Allow Posting and Budgeting. Parent values cannot be used for budgeting or posting.

To set the Third Party Control Account segment qualifier:

Enter Payables, Receivables, or Yes for the Third Party Control Account to designate the account as a Control Account. Access to this account will be restricted to Oracle Payables, Receivables, and Inventory.

If you do not specify the account as a control account, you will be able to use the account for all Oracle Applications.

Additional Information: When journals are uploaded through Oracle Web Applications Desktop Integrator, the code combinations for the journals are validated using the value selected for the segment qualifier Third Party Control Account. If the value is selected as either Yes, Customer, Supplier, or Restrict Manual Journals, then the journal upload sends the following error message, "You cannot use control accounts. Please choose a different account." If the value for the account is selected as No, then the journal is successfully uploaded.

To set the Reconciliation Flag segment qualifier:

Enter Yes for Reconciliation Flag to allow reconciliation for natural accounts that should balance to zero.

Related Topics

Designing Your Account Segments, page 1-39

Defining Summary Accounts, page 1-186
Correcting Misclassified Account Types, *Oracle General Ledger User's Guide*
Defining Accounts, page 1-59
Designing Your Accounting Flexfield, page 1-34
Determining Your Account Needs, page 1-37
Designing Your Account Segments, page 1-39
Segment Value Inheritance, page 1-61
Defining Your Account Structure, page 1-44
Defining Hierarchy and Qualifiers Information, *Oracle Applications Flexfields Guide*
Key Flexfields in Oracle Applications, *Oracle Applications Flexfields Guide*
Oracle Financials for European Localizations User Guides

Parent and Child Values and Rollup Groups

You can create parent-child relationships for account segments with a validation type of Independent or Table. You cannot create parent-child relationships for dependent value sets or value sets with a validation type of None.

Note that parent and child value sets have a relationship different from the relationship between independent and dependent values.

See: Designing Your Accounting Flexfield, page 1-34

See: Planning Your Summary Accounts, page 1-177

The following figure shows an example of rollup groups with a value set that has parent and child values.

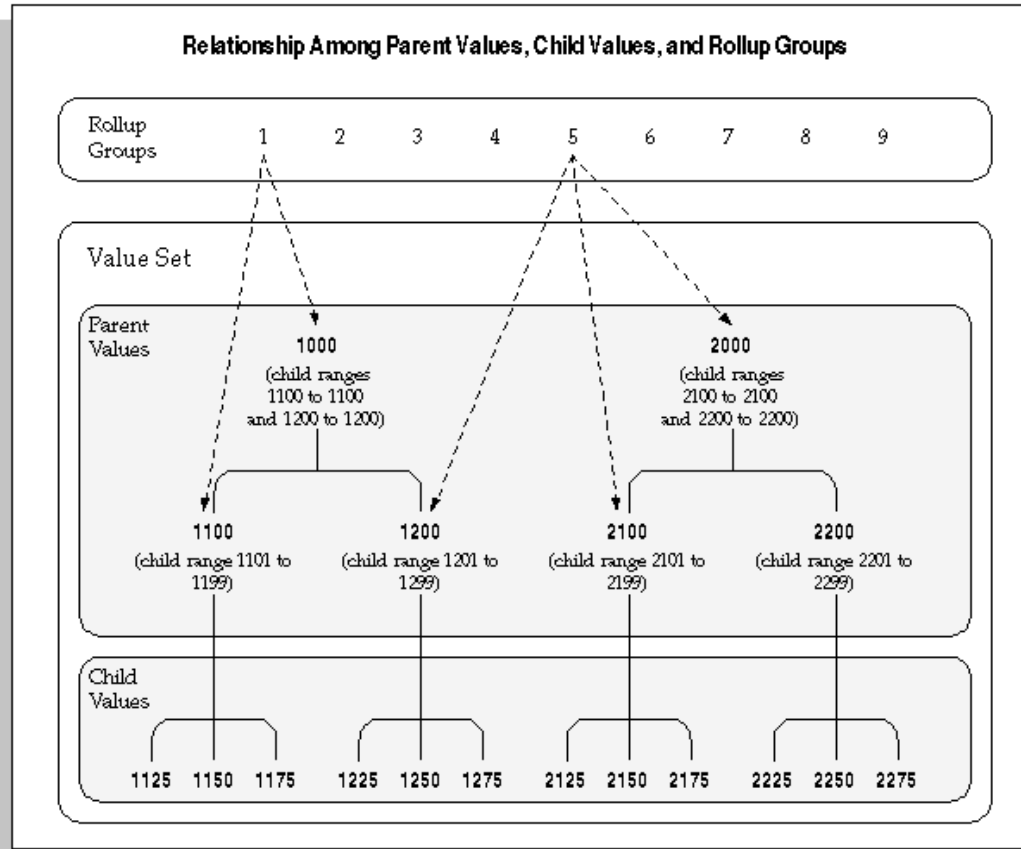

For a text description of the preceding figure, see Text Description of Relationship Among Parent Values, Child Values, and Rollup Groups, *Oracle General Ledger Online Help*.

Parent Value

A parent value is a value that has one or more child values associated with it. A parent value can be assigned to a rollup group. You create parent-child relationships by defining a range of child values that belong to a parent value. You can use parent-child relationships for reporting and other application purposes. In the figure above, account 1000 is a parent value with child values 1100 and 1200. Account 1100 is a parent value with child values 1125, 1150, and 1175.

Child Value

A child value is a value that lies in a range of values belonging to a parent value. A child value can belong to more than one parent value. A child value is not a dependent value; that is, the actual value of the child does not depend on the value of another segment. You create parent-child relationships by defining a range of child values that belong to a parent value. In the figure above, accounts 1125, 1150, and 1175 are child values of parent value 1100.

"T" Value

If you plan to use summary accounts, you should specify the pseudo parent value "T" for each segment. This segment should not have any child values assigned to it. The value "T" is reserved by the system for use in Summary Accounts and represents all child values for that segment.

Warning: The segment value "T" should only be used to mean all segment values, in other words, the total of all parent values. You cannot use it for any other purposes.

Rollup Group

A rollup group is a collection of parent values. Only parent values can be assigned to a rollup group. Parent values and child values belong to the same value set, which is then attached to a key flexfield segment.

A rollup group allows you to group related parent values for creating summary templates. Given a summary template, General Ledger creates summary balances using all parent values assigned to that rollup group.

You define rollup groups using the Rollup Groups window before you define your key segment values. Then, you assign your parent values to the rollup groups when you define the parent values.

See: Rollup Groups Window, *Oracle Applications Flexfields Guide*
Segment Values Window, *Oracle Applications Flexfields Guide*

Rollup groups are separate from parent-child relationships. You can assign any parent value to a given rollup group, regardless of that parent value's position in a value hierarchy you might create. In the previous figure, rollup group 5 is composed of parent values 2000, 2100, and 1200. In this case the parent values in the rollup group are from different branches in the value set hierarchy.

Creating Parent-Child relationships and Rollup Groups

Oracle Applications provides you with windows to define relationships between parent and child values. You create these relationships by defining a parent value and assigning a range of values to become the children of the parent value.

For instructions on how to define rollup groups, see *Oracle E-Business Suite Flexfields Guide*.

You can also use the Account Hierarchy Manager to define new rollup groups then graphically create parent-child relationships and assign parent values to rollup groups.

For information on the Account Hierarchy Manager, see: *The Account Hierarchy Manager*, page 1-66.

An Independent value set provides a predefined list of values for a segment. A

Dependent value set is also a list of values, but the list of available values and their associated meanings depends on which independent value is selected for the previous flexfield segment. You can see the relationship between independent and dependent value sets and parent values and child values in the following diagram:

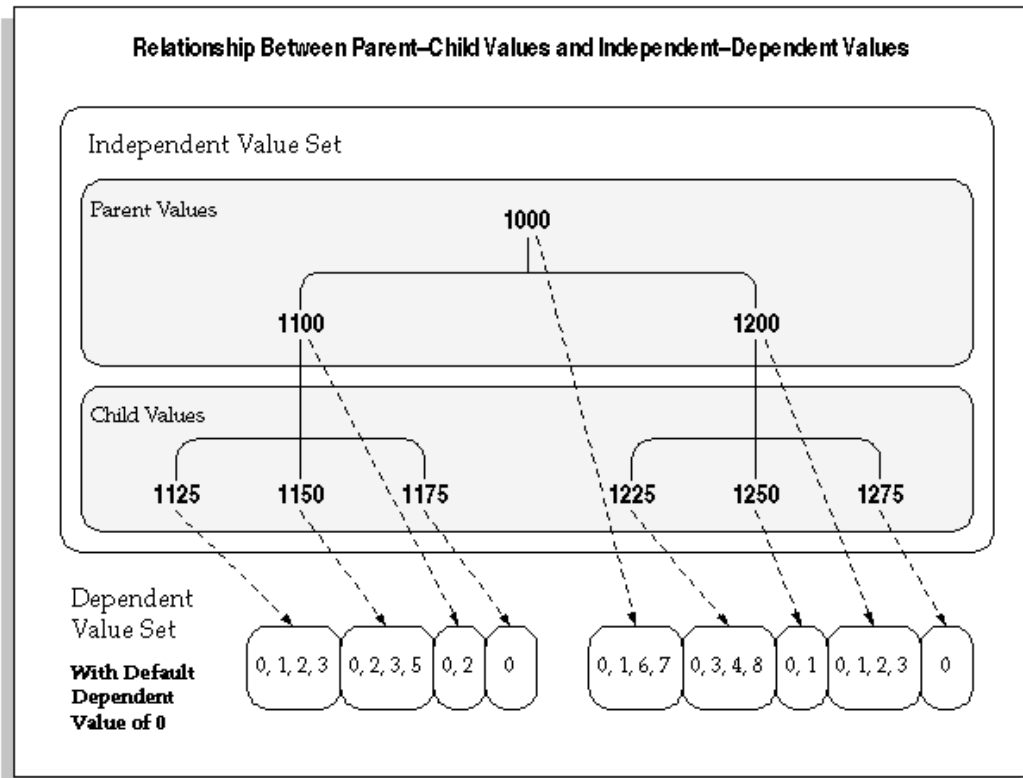

For a text description of this figure, see Text Description of Relationship Between Parent-Child Values and Independent-Dependent Values, *Oracle General Ledger Online Help*

Oracle Applications stores parent-child relationship information in the FND_FLEX_VALUES and FND_FLEX_VALUE_HIERARCHIES tables.

Parent-Child relationships Using Validation Tables

You can create parent-child relationships for any independent value set used by a key flexfield segment. If your value set is a Table validation type value set, you can also use the Define Segment Values form to create parent values for the values in your table. You cannot create new child values using this form, however (you must create your own application form to maintain your validation table). Oracle Applications stores your parent values for you in the Oracle Application Object Library table and does not add your new parent values to your validation table. In the previous diagram, the parent values would reside in the Object Library table, and the child values would reside in your validation table, though all the values are part of the same value set.

Warning: Do not use the Value Sets form to enter parent values that already exist as values in your validation table. Doing so can cause data corruption issues. If two different descriptions for the same value exist, you will not be able to choose values from the list of values on that segment.

Note: You must run the program called Setup Flattening Program for Table Validated Value Sets whenever you change the parent/child hierarchies or add segment values to the value set.

Related Topics

Overview of Values and Value Sets, *Oracle Applications Flexfields Guide*

Rollup Groups Window, *Oracle Applications Flexfields Guide*

Value Set Windows, *Oracle Applications Flexfields Guide*

Validation Table Information Window, *Oracle Applications Flexfields Guide*

Segment Values Window, *Oracle Applications Flexfields Guide*

Defining Segment Values, *Oracle Applications Flexfields Guide*

Defining Accounts

Define new accounts by creating new combinations of account segment values. You must define all new accounts manually if you do not allow dynamic insertion to create new accounts automatically.

You can enable or disable specific account combinations at any time.

Note: Use the Summary Accounts window to define or maintain summary accounts.

Prerequisites

- Define your chart of accounts structure and choose whether to enable dynamic insertion. For new charts of accounts, you must enable Dynamic Insertion to successfully complete your ledger options when creating accounting setups in Accounting Setup Manager.
- Define your account segment values.
- Create an accounting setup using Accounting Setup Manager. The accounting setup must have a complete status.

- Assign a data access set to the GL: Data Access Set profile option for your responsibility.

To add a new account:

1. Navigate to the GL Accounts window.
2. Enter the account combination you want to add. General Ledger checks the account combination against your security and cross-validation rules. If you enter a valid account segment combination, General Ledger automatically displays the account Type of the natural account segment value.
3. (Optional) If you enter an Effective Date range, your account will only be effective during the days defined by the From and To dates.
4. Select Enabled to activate the account. If you entered an Effective Date range, the account is only enabled within that date range.
5. Select Preserved to maintain the current attributes associated with this account. The default setting is unpreserved.

Note: Individual segment value attributes override the account attributes you set here. For example, should you disable an account segment value and run the Segment Value Inheritance program, all accounts that include that segment value and not marked Preserved, will also be disabled.

6. Choose whether to Allow Posting and Allow Budgeting for the account.

Note: You cannot Allow Posting for the Net Income account which is specified for a ledger with average balance processing enabled.

Oracle Receivables Note: Receivables does not use the Allow Budgeting option.

7. (Optional) Specify an alternate account combination for this account combination. The alternate account, if specified, is used by the Journal Import program and the Create Accounting program in Subledger Accounting to replace the original account combination if the latter is disabled or end-dated.

Additional Information: The alternate account will not be used to replace an account combination that has posting/budgeting disabled.

Additional Information: The balancing segment value for the alternate account must be the same as the original account.

8. Choose whether you would like this account included in Global Reconciliation.
9. Save your work.

To disable an account:

Prerequisites

Verify that all subledger transactions that use this account are complete. For example, in Payables, complete the Payables Transfer to General Ledger process before disabling an account that would be updated by the transfer.

1. Navigate to the GL Accounts window.
2. Query the Account you want to disable.
3. De-select Enabled.
4. Save your work.

Note: The Oracle Workflow Business Event System, introduced in Release 2.6, allows products to seed business events and event subscriptions.

Disabling an account is a seeded business event. See: Business Events, page 7-1.

Segment Value Inheritance

The Segment Value Inheritance program automatically propagates the attributes of a segment value to all account combinations that contain that segment value.

To protect account combinations from changes when you run the Segment Value Inheritance program, check the Preserve check box in the GL Accounts window. See: Defining Accounts, page 1-59.

You can assign attributes at two levels:

- The individual segment value in the Segment Values window. See: Defining Segment Qualifiers, page 1-52.
- The account combination in the GL Accounts window.

For example, you can disable the 200 cost center segment in the Segment Values

window, but retain existing account combinations using cost center 200 by marking the Preserve check box for each combination in the GL Accounts window. Then, when you run the Segment Value Inheritance program, all account combinations that contain the 200 cost center will be disabled except for those you preserved and no new combinations will be created during data entry. You can view the account code combinations that have been changed in either the GL Accounts window or the Segment Value Inheritance Execution Report.

Warning: Individual segment value attributes override account combination attributes. See the table below for guidelines.

How Segment Value Attributes Override Account Code Combination

Segment Value Attribute	Account combination attribute in GL Accounts window	Result When Running the Segment Value Inheritance program and the Account Combination is not Preserved
Segment Value Disabled	Account combination enabled	All account combinations that contain that segment value will be disabled.
Segment Value Enabled	Account combination disabled	All account combinations that contain that segment value will be enabled.
Budgeting Not Allowed	Budgeting Allowed	All the account combinations that contain that segment value will not allow budgeting.
Budgeting Allowed	Budgeting Not Allowed	All account combinations that contain that segment value will allow budgeting.
Posting Not Allowed	Posting Allowed	All account combinations that contain that segment value will not allow posting.
Posting Allowed	Posting Not Allowed	All the account combinations that contain that segment value will allow posting.

Segment Value Attribute	Account combination attribute in GL Accounts window	Result When Running the Segment Value Inheritance program and the Account Combination is not Preserved
From Date	Latest date used	If you have a three-segment accounting flexfield, and each segment value has a different start date, the segment value with the latest start date determines the effective date of that account combination.
To Date	Earliest date used	If you have a three-segment accounting flexfield, and each segment value has a different end date, the segment value with the earliest end date determines the effective date of that account combination.
Control Account: No	N/A	All the account combinations that contain that segment value will not become control accounts.
Control Account: Yes	N/A	All the account combinations that contain that segment value will become control accounts.
Control Account: Payables	N/A	All the account combinations that contain that segment value will become Payables control accounts.
Control Account: Receivables	N/A	All the account combinations that contain that segment value will become Receivables control accounts.
Reconciliation: Yes	No	All the account combinations that contain that segment value will allow Global Reconciliation.

Segment Value Attribute	Account combination attribute in GL Accounts window	Result When Running the Segment Value Inheritance program and the Account Combination is not Preserved
Reconciliation: No	Yes	All the account combinations that contain that segment value will not allow Global Reconciliation.

To populate attributes of a segment value to all account combinations containing that segment value:

1. Navigate to the GL Accounts window.
2. Query the account combinations you want to protect from changes and check the Preserve check box.
3. Save your work.
4. Navigate to the Segment Values window.
5. Change the attributes associated with your chosen segment value.
6. Save your work.
7. Navigate to the Key Flexfield Segment window.
8. Check the Freeze Flexfield Definition check box to freeze your accounting flexfield structure.
9. Navigate to the Submit Requests window.
10. From the List of Values, choose Program - Inherit Segment Value Attributes. In the parameters window, choose Yes or No to automatically generate the Segment Value Inheritance Execution Report. The program automatically updates the accounting flexfield structure assigned to the Data Access Set for your responsibility. If you want to update another accounting flexfield structure, you must use the responsibility for that structure.
11. Submit your request.
12. (Optional) If you choose to generate the Segment Value Inheritance Execution Report, note the concurrent request ID. The report lists all account combinations that have been updated and details which attributes were changed.

Warning: Check the Freeze Flexfield Definition check box to protect your accounting flexfield structure after you change attributes associated with your segment value.

Tip: If you want to protect the updated account combinations from any additional changes, query the account combinations in the GL Accounts window and check the Preserve check box.

Note: The Oracle Workflow Business Event System, introduced in Release 2.6, allows products to seed business events and event subscriptions.

A General Ledger account disabled by the Inherit Segment Value Attributes program is a seeded business event. See: Business Events, page 7-1

Table Validated Chart of Accounts

If you run the Inherit Segment Value Attributes program for a chart of accounts that contains a table validated value set, the table must contain two columns: last update date and creation date. Both these columns must contain values; they cannot be Null. If the table does not have these columns, the Inherit Segment Value Attributes program cannot determine which segment value's attributes have changed since it was last run, and it assumes that no segment value changed. The execution report shows the same information for both the original and current attributes and the Inherit Segment Value Attributes program issues a warning upon completion.

Note: You must run the program called Setup Flattening Program for Table Validated Value Sets whenever you change the parent/child hierarchies or add segment values to the value set. This program moves the relevant information from your table validated value set into GL hierarchy and security tables.

Related Topics

Designing Your Accounting Flexfield, page 1-34

Defining Segment Qualifiers, page 1-52

Defining Key Flexfields, *Oracle Applications Flexfields Guide*

Defining Segment Values, *Oracle Applications Flexfields Guide*

Defining Summary Accounts, page 1-186

The Account Hierarchy Manager

Account Hierarchy Manager Overview

With the Account Hierarchy Manager you can graphically create, maintain, and review account structure hierarchies. You can define new parent and child segment values, as well as change parent/child dependencies. You can also create new rollup groups from the Account Hierarchy Manager and have your changes reflected automatically in both the Key Segment Values and Rollup Groups windows.

Note: When you change parent/child relationships that affect existing summary accounts, run the Incremental Add/Delete Summary Templates program to update your summary account balances.

See: Maintaining Summary Accounts, page 1-189

Note: The Account Hierarchy Manager allows you to graphically create and modify account hierarchies and related information stored in General Ledger. You can only use the Account Hierarchy Manager for segments with value sets using Independent validation.

Note: There are two applications that allow you to graphically create and modify account hierarchies and related information stored in General Ledger. The Account Hierarchy Manager is accessed through the General Ledger Navigator. Applications Desktop Integrator's Account Hierarchy Editor is a client server application accessed from your desktop.

Prerequisites

- Define the profile option TCF: Host.
- Define the profile option TCF: Port.
- (Optional) Define the profile option GL AHM: Allow User to Modify Hierarchy, *Oracle General Ledger Reference Guide*.

Parent Levels in an Account Hierarchy

The diagram below illustrates the concept of parent levels in an account hierarchy. This concept is used throughout the remainder of this chapter.

A parent level contains a parent segment value that has one or more child segment values associated with it. Parent levels are displayed in Account Hierarchy Manager in a top-down fashion. The level 1 parent is always the topmost parent, as shown in the diagram. The remaining parent levels, starting with level 2, are referred to as lower level parents.

Parent Levels in an Account Hierarchy

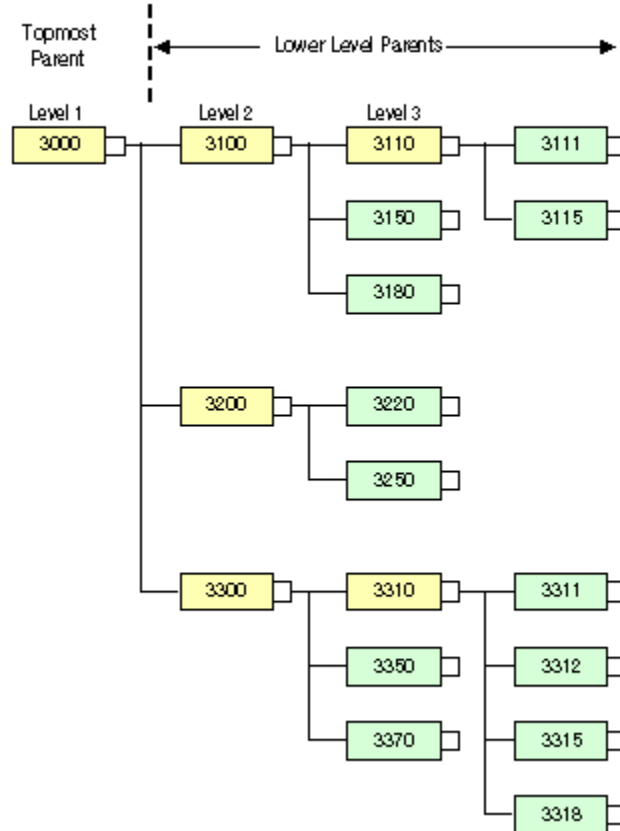

As illustrated in the diagram, a parent value can be a child of a higher level parent. For example, in the diagram, parent value 3110 has two child segment values, 3111 and 3115. The parent is itself a child of the higher level parent value 3100, which also includes the child values 3150 and 3180. Parent value 3100 is, in turn, a child of the topmost parent value, 3000, which also includes the lower level parent values 3200 and 3300, as well as all of their child values.

When you select a parent level in the Account Hierarchy Manager, you are selecting the parent segment value plus all of its child values, which include lower level parents and their associated child values. For example, if you select the parent value 3300 from the hierarchy shown in the diagram above, you are selecting the values 3300, 3310, 3311, 3312, 3315, 3318, 3350, and 3370.

Related Topics

- Planning Your Hierarchies, page 1-68
- Security, page 1-68
- The Account Hierarchy Manager Interface, page 1-70
- The Account Hierarchy Manager Menu, page 1-76
- Adding or Changing Account Hierarchies, page 1-79
- Adding or Changing Parent Values, page 1-81
- Adding or Changing Child Values, page 1-84
- Adding or Changing Rollup Groups, page 1-86
- Closing the Account Hierarchy Manager, page 1-89

Planning Your Hierarchies

Plan your hierarchies carefully. When you create and save Parent and Child segment values, they become permanent. You cannot change or delete Parent or Child segment values using the Account Hierarchy Manager or Oracle General Ledger. You can only disable them. Disabled segment values are displayed in the Account Hierarchy Manager as greyed out.

Related Topics

- Security, page 1-68
- The Account Hierarchy Manager Interface, page 1-70
- The Account Hierarchy Manager Menu, page 1-76
- Adding or Changing Account Hierarchies, page 1-79
- Adding or Changing Parent Values, page 1-81
- Adding or Changing Child Values, page 1-84
- Adding or Changing Rollup Groups, page 1-86
- Closing the Account Hierarchy Manager, page 1-89

Security

The Account Hierarchy Manager has security rules that work together. You can control read only or read/write access and control access to hierarchies, segment values, and charts of accounts. The security rules are outlined below:

- Read Only, Read/Write Security
 - Read Only - Disables you from modifying or saving hierarchies or segment values

and parameters. You can only query, view hierarchy, view details, and export to a tab delimited file. Read Only is displayed in the title bar of the Account Hierarchy Manager.

Read/Write Security - Gives you read/write access to all segment values in the Chart of Accounts. Segment Value Security may limit the segment values you can access.

Set the profile option GL AHM: Allow Users to Modify Hierarchy to No for Read Only, Yes for Read/Write access. You can set this profile option at the site, responsibility or user level. See: *Setting General Ledger Profile Options, Oracle General Ledger Reference Guide*

- Segment Value Security - An Oracle Applications feature that lets you exclude a segment value or ranges of segment values for a specific user responsibility.
- Chart of Accounts Security - You have access to those charts of accounts associated with your user responsibility(s). If you need access to charts of accounts not available to you, see your system administrator.

The Account Hierarchy Manager, page 1-66

Planning Your Hierarchies, page 1-68

The Account Hierarchy Manager Interface, page 1-70

The Account Hierarchy Manager Menu, page 1-76

Adding or Changing Account Hierarchies, page 1-79

Adding or Changing Parent Values, page 1-81

Adding or Changing Child Values, page 1-84

Adding or Changing Rollup Groups, page 1-86

Closing the Account Hierarchy Manager, page 1-89

Starting the Account Hierarchy Manager

To start the Account Hierarchy Manager, choose Setup > Accounts > Manager from the Navigator.

Choose:

- Yes - to use the Account Hierarchy Manager to edit existing hierarchies or create new hierarchies. You can save your changes.
- No - to use the Account Hierarchy Manager only to view account hierarchies.

Note: The profile option GL AHM: Allow Users to Modify Hierarchy governs your ability to modify charts of accounts. See: *Security*, page 1-68

Related Topics

Security, page 1-68

The Account Hierarchy Manager Interface, page 1-70

The Account Hierarchy Manager Menu, page 1-76

Adding or Changing Account Hierarchies, page 1-79

Adding or Changing Parent Values, page 1-81

Adding or Changing Child Values, page 1-84

Adding or Changing Rollup Groups, page 1-86

Closing the Account Hierarchy Manager, page 1-89

The Account Hierarchy Manager Interface

The Account Hierarchy Manager interface consists of multiple windows to help you find, manage, and create hierarchies.

- **Chart of Accounts- Segments window:** Lists all the Charts of Accounts you can access subject to security rules, page 1-68. For example, you can see US Operations Chart of Accounts and the corresponding segments of Company, Department, Account, Sub-Account, and Product.
- **Query Values window:** Helps you find existing segment values using a variety of search criteria.
- **Values List window:** Lists segment values returned from search criteria specified in the Query Values window.
- **Hierarchy window:** Graphically displays all parents and children belonging to a segment selected in the Values List window.
- **Attributes window:** Displays all attributes for parent and child values listed in the Hierarch window.

The Account Hierarchy Manager displays the following icons to represent hierarchy relationships in many of the windows.





Icon	Level
	Top Parent Level - Represents an entire charts of accounts structure.
	Charts of Accounts Segment - Represents an individual segment of a particular chart of accounts structure.
	Parent Level - Represents a parent segment value.
	Child - Represents a child segment value.

Chart of Accounts - Segments Window

The Chart of Accounts-Segments window lists all the Chart of Accounts you can access subject to Chart of Accounts Security, page 1-69

To display Parents and Children in a graphical hierarchy:

1. Expand any Chart of Accounts folder to view the individual segments, such as Company, Department, Account, etc.
2. Highlight a specific segment and choose Find in the Query Values window.
The window changes to the Values List window and displays all the Parent and Child values for that segment.
3. Highlight any parent value and choose the View Hierarchy button.
The Hierarchy window appears. Parent and Child values are displayed in a graphical hierarchy.

Query Values Window

Enter search criteria in the Query Values window to search for existing segment values. Values you can access are subject to Segment Value Security , page 1-69. Criteria entered in the Parent and Child tabs work together in your search. The Parent and Child tabs have Values, Status, and Dates tabs to help you limit your query. You can sort the results of your search by Value or Description.

Only the Values tab lists options that are different for the Parent or Child tabs.

Parents /Values Tab

- All Levels - Includes all levels of parent values.

- Top level - Includes only top level parents.
- None - Omits all parents from the search.
- From - Defines the beginning range of values.
- To - Defines the ending range of values.
- Description - Limits your search to values with descriptions that match the description or partial description you enter. Use % to enter partial descriptions.

Children/Values Tab

- All - Includes all child values.
- None - Includes no child values. Check this option if you do not want to find any child values in your search.
- Unassigned - Includes those child values that have not been assigned to parents.
- From - Defines the beginning range of values.
- To - Defines the ending range of values.
- Description - Limits your search to values with descriptions that match the description or partial description you enter. Use % to enter partial descriptions.

The following options apply both to Parent and Child tabs:

Status Tab

- All - Finds enabled and disabled segment values
- Enabled - Finds enabled segment values only
- Disabled - Finds disabled segment values only

Dates Tab

- All - Finds segment values without any effective date limitation.
- From/To - Finds segment values for a specified effective date range. You must enter the specific From and To dates for your query.

Note: You must clear the All Dates check box to enter date ranges. Use the format MM-DD-YYYY when entering dates.

Note: When you are specifying your search criteria, be sure to

search using both the Parent tab and Child tab. Both of these tabs work in conjunction. For example, if you want to find only parent values ranging from 1000-2000, enter the range 1000-2000 in the Parent/Values tab. Select the Child/Values tab and specify that no child values should be displayed. Otherwise, the query will return parent values between 1000-2000 and all child values.

Query Examples

The examples below demonstrate two ways to use the Query Values window.

Example 1: To find only parent values that are enabled and contain the word Total in their description, you would enter the following:





1. Select the Parent/Values tab, and enter %Total% in the Description field.
2. Select the Parent/Status tab and check the enabled check box.
3. Select the Child/Values tab and check the None check box to indicate no child values.
4. Select the Find button to launch your query.

Example 2: To find only unassigned child values ordered by Description, enter the following:

1. Select the Parent/Values tab and check the None check box to indicate no parent values.
2. Select the Child/Values tab and check the Unassigned check box to find child values that have not been assigned to parents.
3. Leave the status for both parent and child to All.
4. Leave the dates for both parent and child to All Dates.
5. In the Order By field, enable the Description check box to order your query results by Description.
6. Select the Find button to launch your query.

Values List Window

Expand a Chart of Accounts, select a Segment and choose Find in the Query Values window. The Account Hierarchy Manager displays 100 segment values at a time in the Values Detail window. You can choose the arrows to scroll through the list.

Arrows	Description
	displays the first 100 segment values in your list
	displays the previous 100 segment values in your list
	displays the next 100 segment values in your list
	displays the last 100 segment values in your list

Values Detail Window

The Account Hierarchy Manager displays your hierarchies and attributes in two windows:

Note: The title of the Values Detail window is dynamic to reflect the segment you are working with. For example, highlight a parent value for the account segment in the Account Values window and choose the View Hierarchy button from the toolbar. The parent and its children are displayed in the Hierarchy and Attributes sub windows of the *Account Values Detail* window. The displayed title of the Values Detail window, in this case, is *Account Values Detail*.

Hierarchy window: Displays your hierarchies graphically. From a Hierarchy window, you can build, modify, and view account hierarchies.

To build a hierarchy, select a parent value from the Values List window and choose the View Hierarchy button from the toolbar. The parent value and all its children are displayed in the Hierarchy window.

To continue building a hierarchy, select additional values from the Values List window, then drag and drop them in the Hierarchy window. Any new values must be added to existing parent values in the hierarchy window. For example, you can select a child value, drag it to the Hierarchy window, then drop it onto any parent value. You can also select a parent value, drag it to the Hierarchy window, and drop it on any parent value.

However, there are instances when you cannot drop a selected value onto an existing value in the hierarchy diagram. For example, you cannot drop a child value onto another child value. The Account Hierarchy Manager will prevent you from completing the drag and drop in these instances.

To remove a value from a hierarchy, select it and choose Remove from the right-click mouse menu.

Attributes window: Lists the attributes of segment values displayed in the Hierarchy

window. Attributes are: Description, Rollup Group, Account Type, Effective Date Ranges, Enabled, Budgeting Allowed, and Posting Allowed.

Related Topics

Security, page 1-68

Displaying Multiple Hierarchies, page 1-75

The Account Hierarchy Manager Menu, page 1-76

Adding or Changing Account Hierarchies with the Account Hierarchy Manager, page 1-79

Adding or Changing Parent Values with the Account Hierarchy Manager, page 1-81

Adding or Changing Child Values with the Account Hierarchy Manager, page 1-84

Adding or Changing Rollup Groups with the Account Hierarchy Manager, page 1-86

Closing the Account Hierarchy Manager, page 1-89

Displaying Multiple Hierarchies

To display multiple hierarchies simultaneously, you must create a new Hierarchy window for each hierarchy. From the Values List window, select the value to use as the parent value of the new hierarchy, then choose View Hierarchy from the View menu.

Displaying Segment Value Details

Segment value details can be displayed in the Parent Attributes window, Child Attributes window or the Attributes window. These windows can be accessed in a variety of ways.

Related Topics

The Account Hierarchy Manager Toolbar, page 1-75

The Account Hierarchy Manager Menu, page 1-76

Mouse Activated Menus, page 1-77





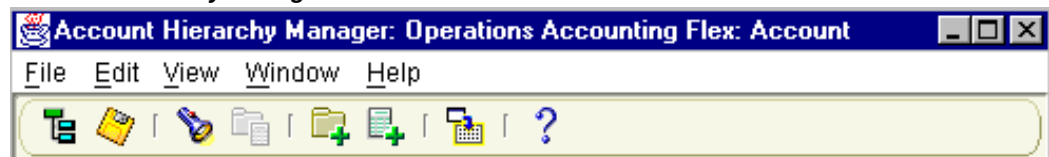



The Account Hierarchy Manager Toolbar

Account Hierarchy Manager Toolbar



The Account Hierarchy Manager toolbar provides push button shortcuts for various

menu commands, as follows:

Pushbutton Shortcut	Description	Pushbutton Shortcut	Description
	View Hierarchy		Save
	View Query		View Values List
	New Parent		New Child
	Export Hierarchy		Help

Related Topics

The Account Hierarchy Manager Menu, page 1-76

Mouse Activated Menus, page 1-77

The Account Hierarchy Manager Menu

File Menu

The File Menu includes the following selections:

Close Window: Closes the active hierarchy window. Only affects the hierarchy window, not the underlying data.

Close All Windows: Closes all active windows.

Save: Launches a concurrent process to apply any changes you have made to the account hierarchy since you last saved it. There is a toolbar icon for this menu selection.

Revert: Discards all changes made since you last performed a Save operation. Reverts to the previously saved version.

Export Hierarchy: Exports a selected hierarchy to a delimited file.

Exit: Exit the Account Hierarchy Manager.

Edit Menu

The Edit Menu includes the following selections:

New Parent: Opens the Parent Attributes window. Complete the Account Value, Description, and Account Type fields to create a new parent value.

New Child: Opens the Child Attributes window. Complete the Account Value, Description, and Account Type fields to create a new child value.

Rollup Groups: Opens the Rollup Groups window, where you can create a new rollup group or edit an existing rollup group.

View Menu

The View Menu includes the following selections:

Hierarchy: Displays the hierarchy of the segment you select in the Values List window.

Values List: Displays the Values List window if it is closed.

Query: Displays the Query Values window.

Description: Enable to display the segment value descriptions.

Window Menu

The Window Menu includes the following options:

Tile Vertically: Tiles Multiple Hierarchies vertically.

Tile Horizontally: Tiles Multiple Hierarchies horizontally.

Related Topics

Mouse Activated Menus, page 1-77

Mouse Activated Menus

Use your right mouse button to access the toolbar pushbutton shortcuts or the commands listed in the Account Hierarchy menus. The right-click menus that appear depend on the window you are working in.

Values List Window

Right-click to use the following options:

Menu Option	Description	Menu Option	Description
View Hierarchy	Displays the hierarchy of the selected segment.	New Child	Opens a blank child attributes window.
New Parent	Opens a blank Parent Attributes window.	View Attributes	Opens the Parent Attributes or Child Attributes window.

You can double-click on any parent or child value to activate the Parent Attributes or Child Attributes window.

Hierarchy Window

Right-click to use the following options:

Menu Option	Description	Menu Option	Description
Remove	Removes the selected segment from the hierarchy.	View Attributes	Opens the Parent Attributes or Child Attributes window.
New Parent	Opens a blank Parent Attributes window.	Export Hierarchy	Allows you to export a selected hierarchy to a delimited file.
New Child	Opens a blank child attributes window.		

Attributes Window

Right-click to use the following options:

Menu Option	Description	Menu Option	Description
Remove	Removes the selected segment from the hierarchy.	Edit Ranges	Allows you to merge, delete, edit, and create new child ranges assigned to a parent.
New Parent	Opens a blank Parent Attributes window.	Delete Row	Allows you to delete a selected row if you have not performed the Save action.
New Child	Opens a blank child attributes window.		

Related Topics

Planning Your Hierarchies, page 1-68

The Account Hierarchy Manager Interface, page 1-70

The Account Hierarchy Manager Menu, page 1-76

Adding or Changing Account Hierarchies, page 1-79

Adding or Changing Parent Values, page 1-81

Adding or Changing Child Values, page 1-84

Adding or Changing Rollup Groups, page 1-86

Closing the Account Hierarchy Manager, page 1-89

Adding or Changing Account Hierarchies with the Account Hierarchy Manager

You can use the Account Hierarchy Manager, instead of the Key Segment Values window in General Ledger, to define a hierarchy for a segment of your chart of accounts. In addition to building new hierarchies, you can use the Account Hierarchy Manager to change existing hierarchies, regardless of where you defined them.

Tip: When you create a new hierarchy, start from the top of the hierarchy organization and build down. In other words, start with a top level grandparent, then add parent nodes and child entries.

You change a hierarchy by:

- Adding child and parent segment values
- Moving child or parent values within a hierarchy
- Removing values

Prerequisite

- Define the Accounting Flexfield structure that represents your chart of accounts.
See: Defining Your Account Structure, page 1-44

To create a new hierarchy:

1. Start the Account Hierarchy Manager by navigating to Setup > Accounts > Manager.
2. In the Chart of Accounts - Segments window, select the Chart of Accounts and Segment for which you want to create a hierarchy. Choose Find in the Query window.
3. From the resulting Value List, select the segment value representing the parent value of your hierarchy. Optionally, you can create a new parent segment value.

See: Adding or Changing Parent Values with the Account Hierarchy Manager, page 1-81

4. Choose New Parent from the File menu.
Complete the fields in the Parent Attributes window.
5. Choose the new parent value from the Values List and select Hierarchy from the View menu.
6. Add values to your hierarchy, as needed, working down from the topmost node.
7. Save your work.

To add values to an existing hierarchy:

1. Select the Chart of Accounts and Segment for the existing hierarchy.
2. Select the segment value that represents the parent value of your hierarchy, and choose Hierarchy from the View menu. The Account Hierarchy Manager displays the parent value and all of its child values.
3. From the Values List window, select the value you want to add to your hierarchy.
4. Drag the selected value to the intended parent value in the Hierarchy window, then drop it.

Note: You can add a parent segment value between existing parent and child values. Drop the new parent value on one of the lines connecting existing parent and child values. The Account Hierarchy Manager inserts the new parent value.

Important: When you change parent/child relationships that affect existing summary accounts the Incremental Add/Delete Summary Templates program to update your summary account balances.

See: Maintaining Summary Accounts, page 1-189

5. Save your work.

To move values within an existing hierarchy:

1. Display the hierarchy you want to modify in the Hierarchy window.
2. Select the value you want to move and drag it to the new intended parent value.

Note: If you are using multiple hierarchy diagram windows, you

can move values between the windows just as you would move values within a single window. Simply select the value and drag it to its new location.

3. Save your work.

To remove values from an existing hierarchy:

1. Display the hierarchy you want to modify in the Hierarchy window.
2. Select the value you want to remove in the Hierarchy window. Choose Remove from the right-click mouse menu.

Note: You are not deleting the value, you are simply removing it from the hierarchy.

3. Save your work.

Related Topics

Planning Your Hierarchies, page 1-68

The Account Hierarchy Manager Interface, page 1-70

The Account Hierarchy Manager Menu, page 1-76

Adding or Changing Parent Values with the Account Hierarchy Manager, page 1-81

Adding or Changing Child Values with the Account Hierarchy Manager, page 1-84

Adding or Changing Rollup Groups with the Account Hierarchy Manager, page 1-86

Closing the Account Hierarchy Manager, page 1-89

Adding or Changing Parent Values with the Account Hierarchy Manager

You can use the Account Hierarchy Manager to add new parent segment values, assign child ranges for a parent segment value, change parent attributes, and merge child ranges.

To create a new parent segment value:

1. Start the Account Hierarchy Manager by navigating to Setup > Accounts > Manager.
2. In the Chart of Accounts - Segment window, select the Chart of Accounts and Segment for the existing hierarchy. Choose Find in the Query Values window.

3. Choose New Parent Value from the Edit menu. The Parent Attributes window appears.
4. Enter a new Segment Value. The segment value must comply with the security rules you defined for the value set associated with the segment. The Account Hierarchy Manager validates the value when you close the Parent Attributes window.
5. Optionally, enter a Description, assign a Rollup Group, and specify a range of Effective Dates.
6. If you are creating a new parent value for the natural account segment, specify an Account Type.
7. Review the Enable checkbox. For, example, if you do not want to use this segment value in the Enter Journals window, uncheck the Enable checkbox.

Note: Once you create and save a new parent segment value, you cannot delete it. You can, however, disable the segment value at any time, by unchecking the Enable check box in the Parent Attributes window.

8. Optionally, assign child value ranges to your parent value (See the next task). You must first save a new Parent Segment before you can assign child value ranges to that parent.
9. Choose OK, then save your work.

To assign child value ranges to a parent value:

1. In the Values List window, select the parent value to which you want to assign child value ranges. Choose View Attributes from the right-click mouse menu.
The Parent Attributes window opens.
2. Choose New. The Range window appears.
3. Select Parent Range or Child Range as the range type.

Note: A parent range includes only the parent segment values falling within the range. A child range includes all child values falling within the range.

4. Enter a segment value range. Values are validated when you close the Parent Attributes window.

Note: You can not enter overlapping child ranges for a parent segment value. The Account Hierarchy Manager prevents you from making an overlapping range selection.

Important: If you change parent/child relationships that affect existing summary accounts, run the Incremental Add/Delete Summary Templates program to update your summary account balances.

See: Maintaining Summary Accounts, page 1-189

5. Choose OK to close the Range window. The newly defined Child or Parent range appears in the Ranges region of the Parent Attributes window.
6. Choose OK when you are finished assigning child ranges.
7. Save your work.

To change the attributes for a parent segment value:

1. In the Values List window, double-click on the parent node whose attributes you want to change.
The Parent Attributes window opens.
2. Make any changes in the Parent Attributes window, then save your work.

Note: If you edit a node that appears more than once in a hierarchy, the Account Hierarchy Manager changes all occurrences of that node to keep the attributes consistent.

Warning: When you save segment value attribute changes to General Ledger, you can also change General Ledger account code combination attributes.

See: Segment Value Inheritance, page 1-61

Merging Ranges

When you create hierarchies using the drag and drop feature of the Account Hierarchy Manager, the system automatically updates parent segment attributes as you build your hierarchies. For example, if you drag the child segment value "1100-Accounts Receivable" to the parent segment value "1000-Assets", the Account Hierarchy Manager changes the attributes of 1000-Assets to include the child range 1100-1100.

If you do this repeatedly for multiple child values, a parent segment can accumulate many entries for child ranges-ranges which are actually adjacent in your chart of accounts. You can use the Account Hierarchy Manager to consolidate adjacent child ranges into a single entry in the Parent Attributes window. For example, separate entries for child ranges 1100-1100, 1200-1200, 1300-1300, and 1400-1400, are combined into one range, 1100-1400.

Note: The character set of the General Ledger database can affect how ranges are merged. For more information, see: *Oracle E-Business Suite Flexfields Guide*.

To merge child ranges for a parent segment value:

1. In the Values List window, double-click on the parent value whose ranges you want to merge.
The Parent Attributes window appears.
2. Choose Merge.
The Preview Merged Ranges window appears. The left region shows the current child ranges. The right region shows the merged ranges as they will appear if you confirm the merge operation.
3. Choose Accept Merge to confirm the merge operation or choose Cancel to abort.

Related Topics

Planning Your Hierarchies, page 1-68

The Account Hierarchy Manager Interface, page 1-70

The Account Hierarchy Manager Menu, page 1-76

Adding or Changing Account Hierarchies with the Account Hierarchy Manager, page 1-79

Adding or Changing Child Values with the Account Hierarchy Manager, page 1-84

Adding or Changing Rollup Groups with the Account Hierarchy Manager, page 1-86

Closing the Account Hierarchy Manager, page 1-89

Adding or Changing Child Values with the Account Hierarchy Manager

You can use the Account Hierarchy Manager to add new child segment values or modify existing child values.

To create a new child segment value for your hierarchy:

1. Start the Account Hierarchy Manager by navigating to Setup > Accounts > Manager.
2. From the Chart of Accounts - Segments window, select the Chart of Accounts and Segment for the existing hierarchy you want to work with.
3. Choose Find in the Query Values window.
4. Choose New Child from the Edit menu.
The Child Attributes window appears.
5. Enter a new Segment Value. The Account Hierarchy Manager validates the value when you close the Child Attributes window.
6. Optionally, enter a Description and specify a range of Effective Dates.
7. If you are creating a new child value for the natural account segment, specify an Account Type. The default is Expense.
8. Mark the Enable check box if you want to use this segment value-for example, in the Enter Journals window in General Ledger.

Note: Once you create and save a new child segment value, you cannot delete it. To disable the segment value at any time, uncheck the Enable check box in the Child Attributes window.

9. Determine whether you want the Allow Posting and Allow Budgeting check boxes enabled or disabled. The defaults are enabled.
10. Choose OK to close the Child Attributes window.
11. Save your work.

To change the attributes for a child segment value:

1. In the Values List window, double-click on the child value whose attributes you want to change.
The Child Attributes window opens.
2. Make any changes in the Child Attributes window, then save your work.

Note: If you edit a child value that appears more than once in a

hierarchy, the Account Hierarchy Manager changes all occurrences of that value to keep the attributes consistent.

Warning: When you upload segment value attribute changes to General Ledger, you can also change General Ledger account code combination attributes.

See: Segment Value Inheritance, page 1-61

Related Topics

Planning Your Hierarchies, page 1-68

The Account Hierarchy Manager Interface, page 1-70

The Account Hierarchy Manager Menu, page 1-76

Adding or Changing Account Hierarchies with the Account Hierarchy Manager, page 1-79

Adding or Changing Parent Values with the Account Hierarchy Manager, page 1-81

Adding or Changing Rollup Groups with the Account Hierarchy Manager, page 1-86

Closing the Account Hierarchy Manager, page 1-89

Adding and Changing Rollup Groups with the Account Hierarchy Manager

You can create new rollup groups or edit existing rollup groups using the Account Hierarchy Manager. Rollup groups are groups of parent segment values you use to create summary accounts.

Important: When you change the contents of a rollup group that is used in a summary template, run the Incremental Add/Delete Summary Templates program to update your summary account balances.

- Rollup groups must be unfrozen for the current chart of accounts. See: Defining Key Flexfields, *Oracle Applications Flexfields Guide*.

To create a new rollup group:

1. Start the Account Hierarchy Manager by navigating to Setup > Accounts > Manager.
2. Choose Rollup Groups from the Edit menu. The Rollup Groups window appears.
3. Choose New. The Rollup Group window appears.

4. Enter a name and description for the new rollup group.
5. Choose OK to close the Rollup Group window.
6. Repeat steps 3 through 6 for each rollup group you want to create. When you are finished, choose OK to close the Rollup Groups window.
7. Save your work.

To change an existing rollup group:

1. Choose the existing hierarchy whose rollup groups you want to change.
2. Choose Rollup Groups from the Edit menu.
3. Select the rollup group you want to change.
4. Choose Edit.
5. After making your changes, choose OK.
6. Repeat steps 3 through 5 for each rollup group you want to change. When you are finished, choose OK.
7. Save your work.

To delete an existing rollup group:

1. Choose the existing hierarchy whose rollup groups you want to delete.
2. Choose Rollup Groups from the Edit menu.
3. Select the rollup group you want to change.
4. Choose Delete.
5. After making your changes, choose OK.
6. Repeat steps 3 through 5 for each rollup group you want to delete. When you are finished, choose OK.
7. Save your work.

Related Topics

Planning Your Hierarchies, page 1-68

The Account Hierarchy Manager Interface, page 1-70

The Account Hierarchy Manager Menu, page 1-76

Adding or Changing Account Hierarchies with the Account Hierarchy Manager, page 1-79

Adding or Changing Parent Values with the Account Hierarchy Manager, page 1-81

Adding or Changing Child Values with the Account Hierarchy Manager, page 1-84

Closing the Account Hierarchy Manager, page 1-89

Defining Rollup Groups, *Oracle Applications Flexfields Guide*

Exporting From the Account Hierarchy Manager

You can export your hierarchies to a delimited file that can be opened and printed in other applications.

To export a hierarchy:

1. Display the hierarchy you want to export in the Hierarchy subwindow of the Values Detail window.
2. Choose the Export Hierarchy icon from the toolbar.
The Export File window opens.
3. Complete the fields in the Export File window.
 - Choose the delimiter you want to use for the export file.
 - In the File field, enter the path and filename for your export file.
Alternatively, you can choose the browse button to explore alternative paths. Once you select a path and filename using Browse, you can edit the path and filename that appear in the File field. Choose Save.
 - Choose OK to export your file.

Related Topics

Planning Your Hierarchies, page 1-68

The Account Hierarchy Manager Interface, page 1-70

The Account Hierarchy Manager Menu, page 1-76

Adding or Changing Account Hierarchies with the Account Hierarchy Manager, page 1-79

Adding or Changing Parent Values with the Account Hierarchy Manager, page 1-81

Adding or Changing Child Values with the Account Hierarchy Manager, page 1-84

Adding or Changing Rollup Groups with the Account Hierarchy Manager, page 1-86

Closing the Account Hierarchy Manager, page 1-89

Closing the Account Hierarchy Manager

To close the Account Hierarchy Manager:

1. Choose File > Exit from the Account Hierarchy Manager menu.
2. If you have not already done so, the system asks if you want to save any changes you've made. Choose Yes to save your work, or No to abandon your changes.

Related Topics

Planning Your Hierarchies, page 1-68

The Account Hierarchy Manager Interface, page 1-70

The Account Hierarchy Manager Menu, page 1-76

Adding or Changing Account Hierarchies with the Account Hierarchy Manager, page 1-79

Adding or Changing Parent Values with the Account Hierarchy Manager, page 1-81

Adding or Changing Child Values with the Account Hierarchy Manager, page 1-84

Adding or Changing Rollup Groups with the Account Hierarchy Manager, page 1-86

Project Tracking in General Ledger

You can set up General Ledger for basic project tracking capabilities. You can set up your accounts to record project activity, and you can use the Financial Statement Generator to produce customized project tracking reports.

If you set up your accounts for project tracking, General Ledger automatically maintains project-to-date balances. The project-to-date balance is based on the project start date you enter when you define a project segment value. Project-to-date balances are useful since project time periods rarely coincide with a fiscal year. General Ledger carries forward project-to-date balances for all accounts, including revenue and expense accounts, even across fiscal years.

For more advanced project tracking functionality, you should use the Oracle Projects products. You can keep detail project information in Oracle Projects, import journals into General Ledger, and report on project balances in General Ledger.

To set up General Ledger for project tracking:

1. When you define your account structure, define a project segment. If necessary, you

can define more than one project segment.

2. Define the project segment values. Enter a new project value (project name, number or code) and a description of each project. Specify a start date and end date for each project, so that you can only enter amounts for that project within that date range. The start date is also the reference point for the project-to-date-balance.

3. Define parent project segment values to summarize projects. For example, you might define project 9999 as the sum of all your other projects. You could then produce a report for project 9999 that shows the total of all your projects.

You can also define project summary accounts to summarize other detail project account balances. Whenever you update the balances of your detail accounts, General Ledger automatically updates the balances of your summary accounts at the same time.

4. Define and assign cross-validation rules to allow only certain segment values in combination with your project. For example, you can define a cross-validation rule that only allows certain expense accounts to be used with certain projects.
5. Create accounts by combining your project segment values with other account segments. This enables you to account for a project any way you want -- within a single cost center, across departments or across companies.

To set up project budgets:

You can enter budgets for projects with your regular budgeting. Assign project accounts to your budget organizations. When your budget organizations prepare their budgets, they can budget project amounts.

You can also perform project budgeting independent of other budgeting. Define a project as a separate budget organization, and prepare its budget independently from the rest of your company.

Related Topics

Overview of Setting Up, page 1-1

Defining Your Cross-Validation Rules, *Oracle Applications Flexfields Guide*

Defining Segment Values, *Oracle Applications Flexfields Guide*

Defining Key Flexfield Segments, *Oracle Applications Flexfields Guide*

Defining Summary Accounts, page 1-186

Defining Accounts, page 1-59

Defining Budget Organizations, *Oracle General Ledger User's Guide*

Defining Budgets, *Oracle General Ledger User's Guide*

Maintaining Project Balances

You keep your project balances current by entering, generating, or importing journals.

To enter project journals:

Enter project journals the same way you enter standard journals, except that you enter a project code in the project segment of your account. You can combine multiple projects in a single journal batch.

To generate project journals:

Set up recurring journal entries for your project tracking.

- Use a skeleton recurring journal entry if the amounts vary each accounting period but the accounts remain the same.
- Use standard recurring journals for transactions whose amounts are the same every accounting period, such as standard accruals or depreciation charges.
- Use formulas to automatically calculate project journal amounts.

To import project journals:

Use Journal Import to import journals to your projects from your feeder systems or other applications.

To generate project allocations:

You can perform simple or complex allocations to or from your projects. Define project allocations the same way you define regular allocations, using a project code in the project segment of your account.

To define a project allocation, you must specify the cost objective (where you want the costs to go), the cost pool (the account from which you want to allocate), and the allocation method. You can define any kind of allocation you want for your projects, including usage-based, rate-based, and step-down allocations. You can include multiple projects in a single allocation entry.

You define your project allocations once and then generate them periodically as necessary.

Related Topics

Creating Journal Batches, *Oracle General Ledger User's Guide*

About Recurring Journals, *Oracle General Ledger User's Guide*

Creating Recurring Journal Formula Batches, *Oracle General Ledger User's Guide*

Creating Allocation Entries, *Oracle General Ledger User's Guide*

About MassAllocations, *Oracle General Ledger User's Guide*

Importing Journals, *Oracle General Ledger User's Guide*

Posting Journals, *Oracle General Ledger User's Guide*

Reporting on Projects in General Ledger

Use the Financial Statement Generator to build custom project reports. By combining report components such as row sets, column sets and content sets, you can produce reports that contain exactly the information you want in the format you want.

Because General Ledger automatically maintains project-to-date balances for all project accounts, you can include any project amounts from the start of your project through the period you designate when requesting your report. In addition, you can report on period-to-date, quarter-to-date, and year-to-date amounts, as well as actual, budget, and variance amounts and percentages.

When you create a project report, you can define a row set to specify the format and content of rows in your reports. You may want to define a standard project row set that you use to produce reports for all your projects.

Define a content set to override the information in your row set and to specify how many reports you want. For example, you can define a content set to produce one report for each project plus a consolidated report that shows the total of all projects.

In addition to Financial Statement Generator reports, you can generate a complete listing of all the projects you have defined in General Ledger by running the Segment Values Listing.

Related Topics

Overview of Financial Statement Generator, *Oracle General Ledger User's Guide*

Mapping Charts of Accounts

A chart of accounts mapping is a set of instructions for mapping accounts or entire account segments from one chart of accounts to another chart of accounts. You can use chart of accounts mapping for consolidation purposes and for secondary ledgers.

Consolidation

A chart of accounts mapping can be assigned to a consolidation definition that is used to transfer consolidation data from your subsidiary ledger to your parent ledger.

The number of mappings that you need depends on the number of different charts of accounts used by each ledger or subsidiary. If all of your ledgers or subsidiaries share the same chart of accounts, you only need to create one chart of accounts mapping for consolidation purposes.

Secondary Ledger

A chart of accounts mapping is required for secondary ledgers that use a different chart of accounts from their respective primary ledgers. If you do not assign a chart of accounts mapping when your primary and secondary ledgers use different charts of accounts, it will cause errors with Oracle Subledger Accounting and General Ledger Posting, depending on the data conversion level for your secondary ledger.

Note: To assign the chart of accounts mapping, use the Primary to Secondary Ledger Mapping page in Accounting Setup Manager.

If your primary and secondary ledgers use the same chart of accounts, you can optionally assign a chart of accounts mapping to the Journal level and Balance level secondary ledgers. This allows you more flexibility to use different rollup rules when transferring journals or balances from the primary ledger to the secondary ledger. For example, you can maintain more detailed information in your primary ledger but maintain more summarized information in your secondary ledger, depending on the rollup rules you define for your chart of accounts mapping.

For more information, see Secondary Ledger.

Definition Access Sets

If you want to secure use, view, or modify access to your chart of accounts mapping, you can secure your mapping using definition access sets. For example, you can prevent a mapping from being used in consolidations, viewed online or in reports, or modified by other users.

See Definition Access Sets, page 1-130.

Prerequisites

- Define your charts of accounts.

To define a chart of accounts mapping:

1. Navigate to the Chart of Accounts Mappings window.
2. Enter a Mapping name and Description.
3. In the Chart of Accounts region, choose the Target chart of accounts and the Source chart of accounts.
4. Select Mapping Rules to map segment rules and/or account rules from your source and target charts of accounts. See: Select Mapping Rules, page 1-94.
5. (Optional) Select the Enable Security checkbox to apply definition access set

security to your chart of accounts mapping.

Definition access sets are an optional security feature that allows you to control access to your General Ledger definitions. For example, you can prevent certain users from viewing, making changes, or using your chart of accounts mapping for consolidation definitions.

If you do not enable security, all users will be able to use, view, modify, and delete your chart of accounts mapping.

If the Assign Access function is available for your responsibility, the Assign Access button is enabled once you select the Enable Security check box. Choose the Assign Access button to assign the definition to one or more definition access sets with the desired privileges.

For more information, see Definition Access Sets, page 1-130.

6. Save your chart of accounts mapping.

Definition Access Set Security

The following describes what Use, View, and Modify access mean as it pertains to chart of accounts mappings:

Use Access: Allows specific users to use the chart of accounts mapping when creating Consolidation Definitions. If you have Use access, you will be unable to view or modify the definition in the Chart of Accounts Mapping window.

View Access: Allows specific users to only view the chart of accounts mapping definition from the Chart of Accounts Mapping window and the Chart of Accounts Mapping Rules report. If you have View access, you cannot make changes to the mapping rules or use the mapping when creating Consolidation Definitions.

Modify Access: Allows specific users to view, delete, and make changes to the chart of accounts mapping. This includes being able to make changes to the definition access set if the Assign Access button is available.

Selecting Mapping Rules

Use segment rules, account rules, or a combination of both to specify how to transfer balances or transactions from your source chart of accounts to your target chart of accounts.

Notes: You must define a segment rule action for each segment in your target's chart of accounts. You cannot define more than one action per segment.

Segment rules: Map the source account segments to the target account segments. For example, you can map the Department segment of your source chart of accounts to the Cost Center segment of your target chart of accounts.

Account rules: Map a specific source account or a range of accounts to a specific

account in your target chart of accounts. For example, you can map source account 02.300.5400.100 to the account 01.100.3000.000.000 in your target chart of accounts. Or, you might map the entire range of the source accounts 02.300.5400.100 through 02.300.6999.100 to account 01.100.3000.000.000 in your target chart of accounts.

Segment rules are preferable to account rules because:

- You can quickly create a chart of accounts mapping by using segment rules. For example, if your target account has only three segments, you can map the entire chart of accounts from the source with just three segment rules.
- If using the chart of accounts mapping for consolidations, consolidations based on segment rules process faster.

Note: Use account rules only for specific exceptions where a source account cannot be mapped correctly with a segment rule.

- Account rules override segment rules if there is any conflict.
- If you define segment rules for dependent segments in your chart of accounts, the list of values for the dependent segment value may appear to contain duplicate entries if you have defined the same dependent value and description for different independent segment values. Choose any entry with the appropriate value; the Global Consolidation System does not use the description

To enter segment rules:

1. Navigate to the Chart of Accounts Mapping window.
2. Enter or query a chart of accounts mapping.
3. Choose the Segment Rules button.
4. For each source segment being mapped, enter the target segment name to which it will map, an Action, and the source segment name. You can use only one action for each target segment. Possible Actions include:

Copy Value From: Copy all values in your source segment to the same values in your target segment. The segments do not have to use the same value set, but must use the same segment values.

Note: This action produces the same result as the Copy Value segment rule in earlier versions of General Ledger. General Ledger also prevents you from copying larger source segments to smaller target segments. For example, you cannot copy the subsidiary value 101 to a target value set with a maximum length of 2.

Assign Single Value: Assign one specific value that will be used for the target segment. You must enter the value that the target chart of accounts will use.

Tip: Use this action when your target account has more segments than your source account.

Note: This action produces the same result as the Single Value segment rule in earlier versions of General Ledger.

Use Rollup Rules From: Map values from your source segments to your target segments using the rule specified in the Rollup Rules region.

5. If you chose the Use Rollup Rules From action in the previous step, enter the mapping rules in the Rollup Rules region.
6. Save your work.

Additional Information: Once you save your work, you cannot modify your rollup rules, except to change the target and source segment detail values. To change a rollup rule, delete it and then create a new one.

To enter account rules:

1. Navigate to the Chart of Accounts Mapping window.
2. Enter or query a chart of accounts mapping.
3. Choose the Account Rules button.
4. Enter the source accounts that you want to consolidate. If you enter multiple ranges, they must not overlap.
5. Enter the target account to which you want to map each source account range.
6. Save your work.

Related Topics

Consolidation Run Options, *Oracle General Ledger User's Guide*

Global Consolidation System, *Oracle General Ledger User's Guide*

Consolidation Workbench, *Oracle General Ledger User's Guide*

Transferring Subsidiary Data to Your Parent, *Oracle General Ledger User's Guide*

Transferring Consolidation Sets, *Oracle General Ledger User's Guide*

Posting Subsidiary Data, *Oracle General Ledger User's Guide*

Creating Eliminating Entries, *Oracle General Ledger User's Guide*

Secondary Ledgers

Primary to Secondary Ledger Mapping

Special Considerations for Average Daily Balance Ledgers, *Oracle General Ledger User's Guide*

Special Considerations for Average Balance Consolidation Ledgers, *Oracle General Ledger User's Guide*

Rollup Rules

You can choose one of four rollup rules when specifying segment rules for your chart of accounts mapping. A rollup rule consists of a Transfer Level value and a Using value, entered in the Segment Rules window. The four rollup rules are shown in the following table:

Rollup Rules

Transfer Level	Using	Resulting Effect
Detail	Detail Ranges	Maps a range of detail values from your source chart of accounts into one detail value in your target chart of accounts. Note: This rule produces the same result as the Detail Rollup segment rule in earlier versions of General Ledger

Detail	Parent	<p>Maps a target value from your source chart of accounts into a detail value in your target chart of accounts.</p> <p>Note: This rule produces the same result as the Parent Rollup segment rule in earlier versions of General Ledger.</p>
Summary	Parent	<p>Maps a source segment parent value into a segment value in your target chart of accounts. This transfers balances from a summary account associated with the source segment parent value.</p> <p>Note: This rollup rule can only be used with the balances consolidation method. You cannot use this rollup rule for mapping accounts from Primary Ledger to Secondary Ledger.</p>

Summary	Parent Ranges	<p>Maps one or more ranges of source segment parent values into a segment value in your target chart of accounts. This transfers balances from the summary accounts associated with the source segment parent values.</p> <p>Note: This rollup rule can only be used with the balances consolidation method. You cannot use this rollup rule for mapping accounts from Primary Ledger to Secondary Ledger.</p>
---------	---------------	---

When specifying a rollup rule, you must enter the Target Segment Detail Value, Transfer Level, and Using fields. If you select the Detail/Parent or Summary/Parent rules, you must also enter a Source Segment Parent Value. If you select the Detail/Detail Ranges or Summary/Parent Ranges rules, you must enter Low and High values for the Source Segment Ranges.

You can enter multiple rollup rules for a single segment as long as the segment values specified in each rule do not overlap.

You can enter more than one source segment range as long as the segment values included in the ranges do not overlap.

Note: An overlap occurs when two or more rollup rules map the same detail source accounts to the same target account. The matching detail source accounts in the different rollup rules may be a partial or complete match.

Related Topics

Consolidation Run Options, *Oracle General Ledger User's Guide*

Global Consolidation System, *Oracle General Ledger User's Guide*

Consolidation Workbench, *Oracle General Ledger User's Guide*

Transferring Subsidiary Data to Your Parent, *Oracle General Ledger User's Guide*

Transferring Consolidation Sets, *Oracle General Ledger User's Guide*

Posting Subsidiary Data, *Oracle General Ledger User's Guide*

Creating Eliminating Entries, *Oracle General Ledger User's Guide*

Creating Accounting Setups

Special Considerations for Average Daily Balance Ledgers, *Oracle General Ledger User's Guide*

Special Considerations for Average Balance Consolidation Ledgers, *Oracle General Ledger User's Guide*

Using Summary Accounts

If you are using Global Consolidation System to consolidate balances from a subsidiary ledger to a parent ledger or to transfer primary ledger balances to a Balance level secondary ledger, you can choose to transfer summary balances from your source ledger's summary accounts to your target ledger's detail accounts. Transferring summary balances generally run faster than transferring detail balances because there is less data to transfer.

Note: You cannot transfer summary balances from a primary ledger to a Journal level or Subledger level secondary ledger. You can only transfer summary balances to a Balance level secondary ledger that relies on the Global Consolidation System to populate its balances.

When you transfer summary balances from your source ledger, General Ledger checks for overlapping accounts. If overlapping accounts are defined solely within your segment rules, the consolidation transfer fails and the system generates an exception report showing the overlapping accounts.

If accounts defined by your segment rules overlap with accounts defined by your account rules, the account rules override the segment rules. General Ledger corrects any double-counted balances that result from the overlapped accounts.

If your source account has more segments than your target, the additional source segments are left unmapped. During a summary balance transfer, the unmapped segment is treated as a summary account segment with a value of "T".

Warning: The segment value "T" should only be used to mean all segment values, in other words, the total of all parent values. You cannot use it for any other purposes.

To map source ledger summary accounts:

1. Specify segment rules for your chart of accounts mapping.
2. For your account segments, select the Use Rollup Rules From action.
3. For your rollup rules, use either the Summary/Parent or Summary/Parent Ranges

rule.

4. Select your summary accounts. For the Summary/Parent rollup rule, enter the summary account in the Source Segment Parent Value field. For the Summary/Parent Ranges rollup rule, enter a range of summary accounts in the Low and High fields of the Source Segment Ranges region.

Tip: Map summary accounts first before mapping the entire chart of accounts.

Related Topics

Mapping Charts of Accounts, page 1-92

Global Consolidation System, *Oracle General Ledger User's Guide*

Consolidation Workbench, *Oracle General Ledger User's Guide*

Period Types

You can define your own period types to use in addition to the General Ledger standard period types Month, Quarter and Year. You use these period types when you define the accounting calendar for your organization.

Defining Period Types

Each ledger has an associated period type. When you assign a calendar to a ledger using Accounting Setup Manager, the ledger only accesses the periods with the appropriate period type. Thus, you can define an accounting calendar with periods of more than one period type; however, each ledger will only use periods of a single period type.

Note: If you close your balance sheet using the Create Balance Sheet Closing Journals program, define enough accounting periods for your period type to allow for two adjusting periods. See: Year End Closing Journals, *Oracle General Ledger User's Guide*.

Warning: Do not change the number of accounting periods per year for a period type. Doing so will cause data corruption.

To define a new period type:

1. Navigate to the Period Types window.

2. Enter a unique Name for your accounting period type.
3. Enter the number of accounting Periods per Year. For example, you could define a Week period type and specify 52 periods per year. You can assign up to 366 accounting periods per fiscal year for any period type, and maintain actual balances for those periods. However, for budgets you can only use the first 60 periods.
4. Enter the Year Type to specify whether the period is part of a fiscal or calendar year. General Ledger uses the year type to assign a year in the accounting period system name when you set up your calendar.
 - Choose *Calendar* to use the year in which an accounting period begins for the system name.
 - Choose *Fiscal* to use the year in which your fiscal year ends for the system name.

For example, assume your fiscal year spans from July 1 to June 30 and the current date is July 15, 2005. If you choose the Calendar year type, General Ledger appends the year 2005 to the period name (JUL-05) because July begins in 2005. If you choose the Fiscal year type, General Ledger appends 2006 to the period name (JUL-06) because the fiscal year ends in 2006.

Using the same July to June fiscal year example, if the current date is March 15, 2005 and you choose the Fiscal year type, General Ledger appends the year 2005 to the period name because the fiscal year ends in 2005.

5. (Optional) Enter a Description for the period type.
6. Save your work.

Related Topics

Defining Calendars, page 1-103

Calendars

Create a calendar to define an accounting year and the periods it contains. You should set up one year at a time, specifying the types of accounting periods to include in each year. Defining one year at a time helps you be more accurate and reduces the amount of period maintenance you must do at the start of each accounting period. You should define your calendar at least one year before your current fiscal year.

Related Topics

Defining Calendars, page 1-103

Adding Periods to a Calendar, page 1-104

Changing a Calendar, page 1-107

Defining Calendars

You can define multiple calendars and assign a different calendar to each ledger. For example, you can use a monthly calendar for ledger, and a quarterly calendar for another.

Calendars you create are validated online. Full calendar validation is launched whenever you exit the Accounting Calendar window. Navigate to Help>View My Requests to view or print the Calendar Validation Report. You may also choose this report from the Standard Reports list to identify any errors associated with the calendar you created.

Securing Calendars

You can secure your calendar definition using definition access sets. Definition access sets are an optional security feature that allows you to control use, view, and modify access to your General Ledger definitions.

For accounting calendars, only View and Modify access are applicable.

View Access: Allows specific users to view the calendar definition from the Accounting Calendar window. If you have view access, you will be unable to make changes to the calendar definition.

Modify Access: Allows specific users to view and make changes to the calendar from the Accounting Calendar window.

Prerequisite

- Carefully consider the type of calendar you need for your organization, since it can be difficult to change your calendar (e.g., from a fiscal year to a calendar year) once you've used it to enter accounting data. Changing your calendar may require assistance from an Oracle consultant.
- Define your accounting period types

To define a new calendar:

1. Navigate to the Accounting Calendar window.
2. Enter a Name and Description for the calendar.
3. Add the periods that make up the calendar year.
4. (Optional) Select the Enable Security check box to apply definition access set

security to the Calendar definition.

If you do not enable security, all users who have access to this calendar definition will be able to view and modify the calendar definition.

If the Assign Access function is available for your responsibility, the Assign Access button is enabled once you check the Enable Security check box. Choose the Assign Access button to assign the calendar definition to one or more Definition Access Sets with the desired privileges. See Definition Access Sets, page 1-130.

If the Assign Access function has been excluded from your responsibility, you will not be able to view the Assign Access button in the Accounting Calendar window. You can still secure the calendar by checking the Enable Security check box, but only Definition Access Sets that are AutoAssigned will be automatically assigned to this calendar. See your System Administrator for more information on Function Security.

5. Save your work.

Note: When you exit the Accounting Calendar window, full calendar validation is launched. You can choose to validate all calendars or the current calendar. Navigate to Help > View > My Requests to view or print the Calendar Validation Report. This report helps you identify any errors in your calendar that might interfere with the proper operation of General Ledger.

Related Topics

[Adding Periods to a Calendar, page 1-104](#)

[Changing a Calendar, page 1-107](#)

[Period Types, page 1-101](#)

[Defining Transaction Calendars, page 1-108](#)

[Calendar Validation Execution Report, *Oracle General Ledger User's Guide*](#)

[Year-End Closing Journals, *Oracle General Ledger User's Guide*](#)

[Definition Access Sets, page 1-130](#)

Adding Periods to a Calendar

Add accounting periods to your calendar to define the number of periods in the calendar year. You can add periods to a calendar at any time. Your calendar can contain both adjusting and non-adjusting accounting periods.

Note: If your calendar is secured using Definition Access Sets, you

must have Modify access to the calendar to make changes.

Note: You cannot assign a calendar to a ledger using Accounting Setup Manager if the calendar contains gaps between periods or it does not have a full fiscal year defined.

When you add periods, keep in mind these important rules:

- Accounting periods cannot overlap, except for adjusting periods. If any of your non-adjusting accounting periods overlap, General Ledger reports an error.
- Adjusting periods must overlap non-adjusting periods.
- Periods of the same period type must be consecutively numbered in ascending order without gaps.
- All periods must have period numbers assigned between 1 and the maximum number for that period type.
- All periods must have quarter numbers assigned between 1 and the maximum number for the period type.
- All non-adjusting periods should contain dates that span the entire calendar or fiscal year.

Note: This should include the 29th day in February for leap years.

- Period ordering must be based on the period starting dates.
- The starting fiscal year must start no earlier than one year before the calendar year and end no later than one year after the calendar year.
- Periods should be defined for the full year.
- You cannot report on a year that has no periods defined.

Note: You cannot perform foreign currency translations for the first accounting period in a calendar. You must define at least one period preceding, as well as the period immediately following, the first period for which you will perform translations.

Note: If you close your balance sheet using the Create Balance Sheet Closing Journals program, define a calendar using a period

type that contains two adjusting periods, one at the beginning of the year and one at the end of the year.

If you are using Average Daily Balance Non-Consolidation ledgers and you close your balance sheet, define a calendar with two adjusting periods at the end of the year. The first adjusting period, representing the last day of the fiscal year, is used to generate the Create Balance Sheet Closing Journals program. The second adjusting period, also representing the last day of the fiscal year, is used to reverse the closing journal. This ensures that the average balance calculation is unaffected in the following year.

See: Year End Closing Journals, *Oracle General Ledger User's Guide*.

To add periods to your calendar:

1. Navigate to the Accounting Calendar window.
2. Enter or query the Name of the calendar.
3. Enter a period Prefix for each accounting period. General Ledger combines this prefix with the year to create the period name. For example, you can enter Jan, Feb, Mar, etc. or Period1, Period2, Period3, etc.

Note: If a period you specify here has been used (opened or used in an open budget or encumbrance year), the resulting name in the Name field cannot be updated.
4. Enter the period Type.
5. Enter the Year of the accounting period. This is the year in which your fiscal year ends. For example, if your fiscal year begins in 2005 and ends in 2006, enter 2006 for all periods in the fiscal year.
6. Enter a number to specify which Quarter of your fiscal year your accounting period is in. General Ledger uses this number to determine how your accounting periods roll up for quarter-to-date balances.
7. Enter the Number of the period within the fiscal year. Be sure to number your accounting periods sequentially, based on the period starting dates you specify in the From/To range.
8. Enter the range of dates (From and To) when the accounting period begins and ends.

General Ledger automatically creates and displays a period Name for each

accounting period. The name consists of your period prefix and the last two digits of either your calendar year or your fiscal year, depending on the year type you assigned in the period type definition. General Ledger displays the period name whenever you choose an accounting period.

9. If you choose to make an accounting period an Adjusting period, it must overlap the dates of other accounting periods. For example, you can define a period called DEC-06 that includes 01-DEC-2006 through 31-DEC-2006. You can also define an adjusting period called DEC31-06 that includes only one day: 31-DEC-2006 through 31-DEC-2006. Both your adjusting and non-adjusting periods should have the same period type associated with your ledger.

Adjusting periods apply only to General Ledger. They are not used in Oracle feeder systems, such as Inventory, Payables, Purchasing, and Receivables.

10. Save your work.

Note: When you exit the Accounting Calendar window, full calendar validation is launched. You can choose to validate all calendars or the current calendar. Navigate to Help > View > My Requests to view or print the Calendar Validation Report. This report helps you identify any errors in your calendar that might interfere with the proper operation of General Ledger.

Related Topics

Defining Calendars, page 1-103

Changing a Calendar, page 1-107

Calendar Validation Execution Report, *Oracle General Ledger User's Guide*

Year-End Closing Journals, *Oracle General Ledger User's Guide*

Changing a Calendar

You can change a period's specifications, except for the period type, as long as the period has not been used for transaction processing in General Ledger or Oracle Subledgers. You cannot change a calendar period that is open, closed, future enterable, permanently closed, or is included in an open budget or encumbrance year.

Note: If the calendar has been secured using definition access sets, you must have Modify access to the calendar to make changes.

Related Topics

Defining Calendars, page 1-103

Defining Transaction Calendars

Each ledger with average balance processing enabled, must be assigned a transaction calendar, which is used to control transaction posting in Oracle General Ledger and Oracle Subledger Accounting. When you define the transaction calendar, you choose which days of the week will be business days. You can also specify other non-business days, such as holidays, by maintaining the transaction calendar.

Transaction calendars ensure that journals created in Oracle General Ledger and Oracle Subledger Accounting, if used, are only posted on valid business days.

Note: General Ledger is currently designed to support daily aggregate balances of up to 35 days per period.

Securing Transaction Calendars

You can secure your transaction calendar definition using definition access sets. Definition access sets are an optional security feature that enables you to control use, view, and modify access to your General Ledger definitions.

For transaction calendars, only View and Modify access are applicable.

View Access: Allows specific users to view the Transaction Calendar definition from the Transaction Calendar window. Users will not be able to assign the calendar to ledgers or make changes to the business days of the Transaction Calendar.

Modify Access: Allows specific users to view and make changes to the Transaction Calendar from the Transaction Calendar window.

To define a transaction calendar:

1. Navigate to the Transaction Calendar window.
2. Enter a Name and Description for the transaction calendar.
3. Optionally, choose Defaults to change the Business Day defaults.
4. (Optional) Select the Enable Security check box to secure the Transaction Calendar definition to prevent some users from viewing or making changes to the calendar.

If you do not enable security, all users who have access to this Transaction Calendar definition will be able to view and modify it. See *Securing Calendars*, page 1-103.

If the Assign Access function is available for your responsibility, the Assign Access button is enabled once you check the Enable Security check box. Choose the Assign Access button to assign the definition to one or more Definition Access Sets with the

desired privileges. See Definition Access Sets, page 1-130.

If the Assign Access function has been excluded from your responsibility, you will not be able to view the Assign Access button in the Transaction Calendar window. You can still secure the Transaction Calendar by checking the Enable Security check box, but only Definition Access Sets that are AutoAssigned will be automatically assigned to this calendar. See your System Administrator for more information on function security.

5. Save your work.

To establish the first transaction day, General Ledger looks at all calendars in the system to determine which calendar has the earliest period. January 1st for the year in which this earliest period occurs is the first transaction day.

To maintain a transaction calendar:

1. Navigate to the Transaction Calendar window.

2. Query the transaction calendar you want to maintain.

General Ledger will display the requested transaction calendar. Note that valid business days have a checkmark in the corresponding Business Day check box.

3. Query the specific date, or range of dates, that you want to maintain.

4. To make a date a valid business day, mark the Business Day checkbox for the date line. To make a date a non-business day, unmark the checkbox.

5. Save your work.

Related Topics

Business Day Defaults, page 1-109

Defining Calendars, page 1-103

Overview of Average Balance Processing, *Oracle General Ledger User's Guide*

Definition Access Sets, page 1-130

Business Day Defaults

When you first define a transaction calendar, General Ledger uses default values for determining which days are business days and which are non-business days. You can change the business day defaults before you have General Ledger generate your initial transaction calendar.

To change the default business days:

1. Navigate to the Transaction Calendar window.
2. Choose Defaults. The Creation Defaults window appears.
3. Mark the checkbox next to those days of the week that you want to be used as default business days when General Ledger generates your initial transaction calendar. Unmark those days that you do not want as default business days.
4. Choose OK to save your work.

Related Topics

Defining Transaction Calendars, page 1-108

Overview of Average Balance Processing, *Oracle General Ledger User's Guide*

Definition Access Sets, page 1-130

Defining Ledgers

A ledger determines the currency, chart of accounts, accounting calendar, ledger processing options and subledger accounting method, if used, for a legal entity, group of legal entities, or some other business purpose that does not involve legal entities.

You define ledgers when you create accounting setups in Accounting Setup Manager. Each accounting setup requires a primary ledger and optionally one or more secondary ledgers and reporting currencies.

Types of Ledgers

There are two types of ledgers: primary and secondary.

Note: Additional actions are required if you are adding a new subledger level secondary/reporting ledger to an existing primary ledger that already has final accounted subledger journal entries. See the Oracle Subledger Accounting Implementation Guide section on Conversion of Historical Data for Reporting Currencies and Secondary Ledgers for the additional actions.

Primary Ledger

The primary ledger acts as the main record-keeping ledger. If used for the purpose of maintaining transactions for one or more legal entities, it uses the legal entities' main chart of accounts, accounting calendar, currency, subledger accounting method, and ledger processing options to record and report on all of their financial transactions. If

used for another business purpose where no legal entities are involved, then the primary ledger is defined with the chart of accounts, accounting calendar, and currency that is suited for the business need. One primary ledger is required for each accounting setup.

Note: The currency for your local statutory reporting (transaction-based, such as VAT or withholding tax) must be the currency of your primary ledger. Oracle supports local compliance by having local currency as the primary ledger currency.

Secondary Ledger

The secondary ledger is an optional, additional ledger that is associated with the primary ledger for an accounting setup. Secondary ledgers can be used to represent your primary ledger's accounting data in another accounting representation that differs in one or more of the following from the primary ledger:

- Chart of accounts
- Accounting calendar/period type combination
- Currency
- Subledger accounting method
- Ledger processing options

Secondary ledgers can be used in many ways. For example, if a legal entity must perform corporate and statutory reporting, you can use the primary ledger to satisfy corporate reporting requirements and then use a secondary ledger to satisfy statutory reporting requirements.

If a legal entity is a subsidiary of a parent company and must produce its financial results according to the parent company's reporting requirements in addition to its own local reporting requirements, then a secondary ledger may be used to satisfy the additional reporting requirement.

Secondary ledgers can be maintained at the following data conversion levels:

- **Subledger:** The Subledger level secondary ledger maintains subledger journals, general ledger journal entries, and balances in the additional accounting representation. This data conversion level uses both Oracle Subledger Accounting and General Ledger Posting to create the necessary journals in both your primary and secondary ledgers simultaneously.
- **Journal:** The journal level secondary ledger maintains your primary ledger journal entries and balances in an additional accounting representation. This type of secondary ledger is maintained using the General Ledger Posting Program. Every

time you post a journal in your primary ledger, the same journal can be automatically replicated and maintained in the secondary ledger for those journal sources and categories that are set up for this behavior.

- **Balance:** The balance level secondary ledger maintains your primary ledger account balances in another accounting representation. This type of secondary ledger requires you to use Oracle General Ledger Consolidation to transfer your primary ledger balances to this secondary ledger.
- **Adjustments Only:** The Adjustments Only Secondary Ledger is an incomplete accounting representation that only holds adjustments. The adjustments can be manual adjustments or automated adjustments from Oracle Subledger Accounting. This type of ledger must share the same chart of accounts, accounting calendar/period type combination, and currency as the associated primary ledger. To obtain a complete secondary accounting representation that includes both the transactional data and the adjustments, you must then combine the adjustments-only secondary ledger with the primary ledger when running reports.

Warning: The following warning message appears if you add the secondary ledger to the existing primary ledger:

Please note that Subledger Accounting will fail to create accounting for transaction reversal and accounting entries derived using business flows if the subledger level secondary ledger is added to a Primary Ledger that has final accounted transactions in any subledger application. Use the SLA Secondary/ALC Ledger Historic Upgrade program to replicate accounting entries in the secondary ledger or reporting currency before creating new transactions in the subledger applications.

For more information on secondary ledgers, see [Secondary Ledgers](#).

Note: If you only need to represent your primary ledger transactions in another currency, you do not need to use secondary ledgers; you can use reporting currencies.

Note: Additional actions are required if you are adding a new subledger level secondary/reporting ledger to an existing primary ledger that already has final accounted subledger journal entries. See the Oracle Subledger Accounting Implementation Guide section on [Conversion of Historical Data for Reporting Currencies and Secondary Ledgers](#) for the additional actions.

For more information on reporting currencies, see [Reporting Currencies](#), page 1-113.

Reporting Currencies

If you want to maintain your accounting for your ledger in multiple currencies, you can use reporting currencies. Reporting currencies are additional currency representations of primary or secondary ledgers. Unlike secondary ledgers, reporting currencies can only differ by currency from their source ledger and must share the same chart of accounts, accounting calendar/period type combination, subledger accounting method, if used, and ledger processing options. Reporting currencies can be used for supplementary reporting purposes, such as consolidation or management reporting. They can also be used if you operate in countries with highly inflationary economies.

Reporting currencies can be maintained at the following currency conversion levels:

- **Balance Level:** The Balance level reporting currency is maintained only for GL account balances by using translation to convert the balances from the ledger currency to the reporting currency. Balance level reporting currencies can be assigned to primary and secondary ledgers using Accounting Setup Manager, or they can be system-generated the first time you run translation using a different currency.
- **Journal Level:** The Journal level reporting currency is maintained for GL journal entries and balances when you post journals in your primary or secondary ledger. This type of reporting currency is maintained using the General Ledger Posting program. Each time you post a journal entry in the associated primary or secondary ledger, another journal is created and posted to the Journal level reporting currency within the same journal batch.
- **Subledger Level:** The Subledger level reporting currency is maintained for primary ledgers only. They maintain a currency representation of the primary ledgers' subledger journals, journal entries, and balances. This type of reporting currency is maintained by Oracle Subledger Accounting (SLA) and the GL Posting program.

Journal level and Subledger level reporting currencies are intended for use by organizations that must regularly and routinely report their financial results in multiple currencies. For example, an organization with a once-a-year need to translate its financial statements to its parent company's currency for consolidation purposes, but no other foreign currency reporting needs should use the balance level reporting currency instead of journal or subledger levels.

The choice of balance level (translation) versus journal or subledger level reporting currencies depends on whether a company wants to track balances or transaction level details in the reporting currencies. Typically, you should consider using journal or subledger level reporting currencies when:

- You operate in a country whose unstable currency makes it unsuitable for managing your business. As a result, you need to manage your business in a more stable currency and still be able to report your transactions and account balances in the unstable local currency

- Your company is multinational, and you need to report financial information in a common currency other than that of the transaction or your ledger's currency.

General Ledger stores reporting currency amounts. These amounts can be used with many other General Ledger features, such as translation, consolidation, multi-currency accounting, and formula journals.

You can use General Ledger's online inquiry features to display information about reporting currencies. You can also request standard reports, as well as create your own custom Financials Statement Generator reports to report in reporting currency balances.

You define reporting currencies when you create accounting setups using Accounting Setup Manager.

See: Reporting Currencies.

Warning: The following warning message appears if you add the secondary ledger to the existing primary ledger:

Please note that Subledger Accounting will fail to create accounting for transaction reversal and accounting entries derived using business flows if the subledger level secondary ledger is added to a Primary Ledger that has final accounted transactions in any subledger application. Use the SLA Secondary/ALC Ledger Historic Upgrade program to replicate accounting entries in the secondary ledger or reporting currency before creating new transactions in the subledger applications.

Ledger Prerequisites

The following need to be defined or enabled in Oracle General Ledger before you can create ledgers using Accounting Setup Manager:

- Chart of accounts
- Accounting calendar
- Transaction calendar, if you plan to use average balance processing and want to ensure journals created in Oracle General Ledger and Oracle Subledger Accounting (SLA) only get booked on valid business days
- Currencies
- Currency conversion rate types and rates, if you plan to use more than one currency
- Journal reversal criteria, if you plan to automatically reverse journals
- The following accounts:

- Retained Earnings account
- Suspense account, if you want to enable suspense posting
- Cumulative Translation Adjustment account, if you plan to translate balances
- Rounding Differences account, if you want to use a specific account to track small currency differences during currency conversion
- Non-Postable Net Income account, if you plan to use average balance processing. This account is used to capture the net activity of all revenue and expense accounts when calculating the average balance for retained earnings.
- Reserve for Encumbrance account, if you plan to use Encumbrance Accounting
- Entered Currency Balancing Account, if you plan to use Oracle Subledgers and want to balance foreign currency subledger journals by the entered currency and balancing segment value
- Ledger Currency Balancing Account, if you plan to use Oracle Subledgers and want to balance subledger journals by the ledger currency and balancing segment value

See: Ledger Options.

Assigning Ledgers to Profile Options

If using Oracle Subledgers, you must assign a ledger to the GL Ledger Name profile option to indicate the ledger that will be used for transaction processing by your subledger applications. The ledger specified is automatically assigned to the GL: Data Access Set profile option to control the ledgers that can be used by Oracle General Ledger.

If you want to access more than one ledger for Oracle General Ledger, assign a data access set to the GL: Data Access Set profile option. This data access set should include the same ledger used by your Oracle Subledgers so you can view subledger data transferred to General Ledger.

See: Data Access Sets, page 1-118.

Ledger Sets

To achieve processing efficiencies, such as opening periods for multiple ledgers or summarizing balances across ledgers using FSGs, you can group multiple ledgers into a ledger set.

All ledgers in a ledger set must share the same chart of accounts and accounting calendar/period type combination. This includes reporting currencies at the Journal and

Subledger levels that you may want to combine with the primary ledger to allow you to synchronize accounting periods or view data across ledgers.

See: Defining Ledger Sets, page 1-116.

Data Access Sets

Data access sets control which ledgers can be accessed by different responsibilities. Data access sets can also limit a user from accessing certain balancing segment values or management segment values or grant read-only or read and write access to data in a ledger.

General Ledger automatically creates a data access set when you define a ledger or ledger set. This system-generated data access set provides full read and write access to ledgers. You can also provide more limited access to your ledgers and ledger sets by defining your own data access sets.

Your System Administrator must assign the data access set that you want to use to the profile option GL: Data Access Set for each responsibility.

See: Data Access Sets, page 1-118.

Defining Ledger Sets

A ledger set is a group of ledgers that share the same chart of accounts and calendar/period type combination. Ledger sets allow you to run processes and reports for multiple ledgers simultaneously.

For example, you can open/close periods for multiple ledgers at once, run recurring journals that update balances for multiple ledgers, or run consolidated financial reports that summarize balances across multiple ledgers in a ledger set.

You can group all types of ledgers in a ledger set, such as primary ledger, secondary ledgers, and reporting currencies (journal and subledger levels), as long as they share the same chart of accounts and calendar/period type combination. The same ledger can belong to multiple ledger sets, and ledger sets can contain other ledger sets.

Reporting Currencies

If using reporting currencies at the journal-level or subledger level, it is recommended that you group reporting currencies with their associated source ledgers in a ledger set. Doing so makes it easier to maintain the same number of open and closed periods for the ledgers and their reporting currencies. It also enables you to view transactions, journals, or balances across ledgers and reporting currencies in a single view.

See: Overview of Reporting Currencies, *Oracle General Ledger User's Guide*.

Securing Ledger Sets

You can secure your ledger set using definition access sets. Definition access sets are an optional security feature that enables you to control use, view, and modify access to your General Ledger definitions.

The following describes what Use, View, and Modify access mean as it pertains to ledger sets:

- **Use Access:** Allows specific users to assign the ledger set to another ledger set definition or data access set. If you have Use Access, you will be unable to view the ledger set definition or make changes to the ledger set.
- **View Access:** Allows specific users to view the ledger set definition from the Ledger Sets window. If you have View Access, you will be unable to make changes to the ledger set, such as adding and removing ledgers or ledger sets.
- **Modify Access:** Allows specific users to view and make changes to the ledger set from the Transaction Calendar window.

Prerequisites

- Define ledgers or ledger sets.

To define a ledger set:

1. Navigate to the Ledger Set window.
2. Enter a name for the Ledger Set.
3. Enter a Short Name for the ledger set.
4. (Optional) Enter a Description for the ledger set.
5. Choose a Chart of Accounts.
6. Choose a Calendar and Period Type.
7. (Optional) Specify a default ledger. The default ledger automatically defaults in all windows where the Ledger field is required.

Note: A Default Ledger is required for Financial Statement Generator (FSG).

8. (Optional) Select the Enable Security checkbox to secure the Ledger Set definition. If you do not enable security, all users who have access to this definition will be able to use, view, and modify the ledger set definition.

If the Assign Access function is available for your responsibility, the Assign Access button will be enabled once you select the Enable Security checkbox.

Choose the Assign Access button to assign the definition to one or more Definition Access Sets with the desired privileges. For more information, see Definition Access Sets, page 1-130.

If the Assign Access function has been excluded from your responsibility, you will be unable to view the Assign Access button in the Ledger Sets window. You can still secure the Ledger Set definition by selecting the Enable Security checkbox, but only Definition Access Sets that are AutoAssigned will be automatically assigned to this Ledger Set. See your System Administrator for more information on Function Security.

9. In the Ledger/Ledger Set column, choose the ledgers and/or ledger sets to be included in the ledger set. Only those ledgers and ledger sets that share the same chart of accounts, calendar, and period type specified for the ledger set definition will be available.

If you use reporting currencies (journal or subledger level), you can choose reporting currencies to be included in the ledger set. Only those reporting currencies that share the same chart of accounts, calendar, and period type specified for the ledger set definition will be available

10. Save your work. The General Ledger Accounting Setup Program will be submitted. Ensure this program completes successfully.

Once saved, a ledger set cannot be deleted. You can only add or remove ledgers and ledger sets from ledger sets.

Note: You must have at least one ledger or ledger set assigned to a ledger set.

Before you can begin using the ledgers contained in your ledger set for transaction processing, you must assign the ledger set to the profile option, GL: Data Access Set.

Related Topics

Creating Accounting Setups

Data Access Sets

Data access sets control which ledgers can be accessed by different responsibilities. Data access sets can also limit a user from accessing certain balancing segment values or management segment values or grant read-only or read and write access to data in a ledger. The ledgers and ledger sets assigned to a data access set must share the same chart of accounts, calendar, and period type.

You can define three types of data access sets:

- **Full Ledger:** Grants access to all the data in a ledger. For example, in a data access set with two ledgers, A and B, you can grant read-only privileges to all the data in Ledger A and grant read and write privileges to all the data in Ledger B.
- **Balancing Segment Value:** Grants access to all or specific ledger/balancing segment value (BSV) combinations. For example, you can have a data access set with Ledger A, and grant read-only privileges to balancing segment value 01, grant read and write privileges to balancing segment value 02, and grant no access to balancing segment value 03 in the same ledger. This is useful for companies that use a small number of ledgers with a high number of balancing segment values to represent multiple companies or legal entities.
- **Management Segment Value:** Grants access to all or specific ledger/management segment value (MSV) combinations. For example, you can have a data access set with ledger A and grant read only privileges to management segment value 100, grant read and write privileges to management segment value 200, and grant no access to management segment value 300. This can only be used if you have specified a management segment in your chart of accounts

Note: The Full Ledger access set type provides better system performance than the Balancing Segment Value or Management Segment Value access set type.

Note: When you assign specific balancing segment values/management segment values, you can specify all values, parent values that include their child values, or child values individually.

You must specify one of the three types for each data access set. Once defined, you cannot alter the type. You can only add or delete ledgers/ledger sets and segment values specified in the data access set.

Oracle General Ledger automatically creates a data access set when the following occurs:

- A ledger is created
- A ledger set is defined

The system-generated data access set for a ledger uses the same name as the ledger. This data access set uses the Full Ledger access set type that provides full read and write access to the ledgers.

The system-generated data access set for ledger sets uses the same name as the ledger set. This data access set uses the Full Ledger access set type that provides full read and

write access to all of the ledgers assigned to the ledger set.

If the level of access provided by the system-generated data access set is sufficient for your needs, you do not need to manually create a data access set; just use the one created by the system.

You only need to create your own data access sets when you want to further limit read and write access to ledgers, ledger sets, or specific balancing segment values or management segment values for a ledger or ledger set.

Full Ledger Access

Full ledger access is required to perform certain operations, such as opening and closing periods, creating summary accounts, creating budgets, and performing Mass Maintenance. Full ledger access means having full read and write access to the ledger and all of its balancing segment values or management segment values.

To obtain full ledger access, your data access set must be one of the following types:

- The Full Ledger data access set type that provides read and write access to the ledger.
- The Balancing Segment Value data access set type that provides read and write access to all balancing segment values for a ledger using the All Values checkbox.
- The Management Segment Value data access set type that provides read and write access to all management segment values for a ledger using the All Values checkbox.

Note: Choosing the All Values check box for the Balancing Segment Value or Management Segment Value access set type is not equivalent to assigning all of the balancing segment values or all of management segment values individually.

To prevent potential errors in processing, such as not being able to open or close a ledger's periods, make sure at least one responsibility has a data access set assigned with full ledger access.

Note: Data Access Sets work with Segment Value Security Rules and Cross-Validation Rules. If you have defined Segment Value Security Rules that prevent certain responsibilities from accessing certain segment values, those rules are combined with data access set security.

For example, if you defined Segment Value Security rules to exclude Balancing Segment Value 01 and then defined data access set security that provides read-only access to values 01-03, the user assigned this responsibility would not be able to read segment value 01 due to the

Segment Value Security rule.

Defining Your Cross-Validation Rules and Defining Segment Values.

Reporting Currencies

If you use reporting currencies, Oracle General Ledger automatically creates both of the following:

- a data access set with the source ledger and the journal-level or subledger-level reporting currencies
- a data access set with the journal-level or subledger-level reporting currency only

The system-generated data access set for a reporting currency uses the same name as the reporting currency. This data access set uses the Full Ledger access set type that provides full read and write access to the reporting currency.

If a ledger set is defined that includes reporting currencies (journal or subledger level), the system-generated data access set for the ledger set uses the Full Ledger access set type that provides full read and write access to all of the reporting currencies assigned to the ledger set.

Planning Your Data Access Sets

Before creating data access sets, consider the following:

Securing Balancing Segment Values

When you create accounting setups in Accounting Setup Manager, it is recommended that you assign specific balancing segment values to legal entities. This enables you to easily identify transactions by legal entity and take advantage of many legal entity features, such as Intercompany Accounting.

Optionally, you can assign balancing segment values to the ledger itself if you want to reserve specific values for non-legal entity related transactions, such as adjustments.

If you assign specific balancing segment values to legal entities and ledgers, you will only be able to use those balancing segment values during transaction processing and journal entry.

Example

Assume the following legal entities share the same primary ledger called Vision Operations. Each legal entity has the following balancing segment values assigned:

Legal Entity and Balancing Segment Value Assignment for Vision Operations

Legal Entity	Balancing Segment Value Assignment
Vision USA	01,02
Vision Services	03
Vision Distribution	04

When entering subledger transactions or journal entries for the ledger, Vision Operations, you will only be able to use the balancing segment values assigned to the legal entities for that ledger, values 01– 04.

If you also assigned one or more balancing segment values to the ledger, such as value 99, then you would also be able to use value 99 to enter journal entries and view data in reports.

When you assign balancing segment values to legal entities and ledgers, all users who have access to the ledger will be able to use those balancing segment values for data entry and reporting. If you want to further limit read-only or read and write access to the balancing segment values, then you must create data access sets to secure those values.

Using the same example above, assume you want to prevent users who enter data for Vision USA from viewing and entering data for Vision Services and Vision Distribution. You can create the following data access set with the following parameters:

- Data Access Set: Vision Services Only
- Data Access Set Type: Balancing Segment Value

Data Access Set

Ledger	Balancing Segment Value	Privileges
Vision USA	01	Read and Write
Vision USA	02	Read and Write

By assigning this data access set to the responsibilities for Vision Services, the Vision Services users will only be able to enter and view data using balancing segment values 01 and 02.

Note: The balancing segment values you secure using data access sets should correspond to the values assigned to the legal entities of a particular ledger. In this example, if you created a data access set that only provided read and write access to balancing segment values 21 and 22, which are not assigned to the legal entities for the Vision USA ledger, users would not be able to enter or view data for any balancing segment value.

Securing Management Segment Values

When securing management segment values for a ledger, take note of the management segment values you used when you assigned the default accounts to the ledger, such as the retained earnings account and the cumulative translation adjustment account. Make sure that your data access set that uses the Management Segment Value Access Set Type includes read and write access to the management segment values you used for the ledger's default accounts.

For example, if your ledger's retained earnings account is 11-000-3110, where 000 is the management segment value, make sure all data access sets using the Management Segment Value Access Set Type includes read and write access to value 000. This will prevent processing errors when users perform certain processes, such as Translation and Posting, that automatically update the ledger's default accounts.

Using Data Access Sets

To use a data access set that allows you to access data in one or more ledgers for transaction processing, you must have your System Administrator assign the data access set to a General Ledger responsibility using the profile option GL: Data Access Set. Each responsibility can have only one data access set assigned.

Because General Ledger uses many profile options that you can assign to General Ledger responsibilities to control journal processing, you should carefully plan your data access sets to combine similar ledgers that will use the same processing options.

For example, the profile option called GL: Owners Equity Translation Rule controls the method to use when translating owner's equity accounts. If you set this profile option to YTD at the Responsibility level, all ledgers in the data access set that are assigned to the same responsibility will use the YTD method. If you combined ledgers that needed to use a mixture of PTD and YTD Translation methods, you will need to change the profile option setting before running Translation for each ledger individually.

Data Access Set Examples

For the examples below, assume you have defined the following ledgers and ledger sets:

- Vision Services Ledger

- Vision Operations Ledger
- Vision Global Industries Ledger Set contains three ledgers: US Operations, Canada Operations, and a Consolidation Ledger

Example A: Full Ledger Access Set Type

Assume you define the following data access set with the Full Ledger Access Set Type:

Example A - Full Ledger Data Access Set Type

Ledgers/Ledger Sets	Privileges
Vision Services	Read and Write
Vision Operations	Read-Only
Vision Global Industries Ledger Set	Read-Only

Responsibilities using this data access set will have full read and write access to the Vision Services ledger. Users can enter journals, perform account inquiries, and run reports for the Vision Services ledger. Users can only view existing data for the Ledgers Vision Operations, US Operations, Canada Operations, and Consolidation, such as querying journals or running reports. They cannot enter journals or update balances for these ledgers because they have read-only access to these ledgers.

Example B: Balancing Segment Value Data Access Set Type

Assume you define the following data access set with the Balancing Segment Value Access Set Type:

Example B: Balancing Segment Value Data Access Set Type

Ledgers/Ledger Sets	Balancing Segment Value	Privileges
Vision Services	All	Read and Write
Vision Operations	01	Read-Only
Vision Operations	20 (Parent of child values 21–29)	Read and Write

Vision Global Industries Ledger Set	All	Read and Write
--	-----	----------------

Users with responsibilities using this data access set will have read and write access to the data in Vision Services and for all of its balancing segment values. Users can only view the existing data in Vision Operations for balancing segment value 01. Users have read and write access to the data in Vision Operations for balancing segment value 20, including its child values (21–29). Users have read and write access to the data in all balancing segment values in Ledger Set, Vision Global Industries.

Example C: Management Segment Value Data Access Set Type

Assume you define the following data access set with the Management Segment Value Access Set Type:

Example C: Management Segment Value Data Access Set Type

Ledgers/Ledger Sets	Management Segment Value	Privileges
Vision Services	All	Read-Only
Vision Operations	001	Read-Only
Vision Operations	003 (Parent of child values 010–020)	Read and Write
Vision Global Industries Ledger Set	All	Read and Write

Users with responsibilities using this data access set can view data for all of the management segment values in Vision Services. Users can only view the data for Vision Operations for management segment value 001. Users can read and write data for Vision Operations for management segment value 003, including its child values (010–020). Users can read and write to data in all management segment values in Ledger Set Vision Global Industries.

Defining Data Access Sets

Prerequisites

- Ledgers must be assigned to accounting setups that have a complete status.

To define a Data Access Set:

1. Navigate to the Data Access Set window.
2. Enter a name for the data access set.
3. (Optional) Enter a Description for the data access set.
4. Enter the name of the Chart of Accounts for the data access set.
5. Enter the Calendar for the data access set. The Period Type will default.
6. Choose a value from the Access Set Type field:
Full Ledger: To grant privileges to an entire ledger or ledger set.
Balancing Segment Value: To grant privileges for all or specific balancing segment values in a ledger or ledger set.
Management Segment Value: To grant privileges for all or specific management segment values in a ledger or ledger set.
7. In the Ledger/Ledger Set column, enter the ledger or ledger set that you want to include in the data access set. You can only choose ledgers and ledger sets that share the same chart of accounts, calendar, and period type as the data access set.

Note: You will not be able to choose a ledger unless it is assigned to a complete accounting setup.

Note: If you use reporting currencies (journal or subledger level), then you may enter a reporting currency that shares the same chart of accounts, calendar, and period type as the data access set.

You can assign the same ledger and/or ledger sets to multiple data access sets, but you cannot assign one data access set to another data access set.

8. If you specified the Full Ledger Access Set Type, skip to step 9. If you specified the Balancing Segment Value or Management Segment Value Access Type, specify one of the following:
 - Check the All checkbox to grant privileges to all balancing or management segment values in the ledger.
 - Enter a specific balancing or management segment value for the ledger or ledger set. To include more than one balancing or management segment value per ledger or ledger set, complete additional rows.

Note: If you specify a parent segment value, then the read-only and read and write privileges are automatically propagated to all of its child values at all levels of the hierarchy.

9. Choose a Privilege:

Read Only: Allows users to view data in ledgers and balancing or management segment values.

Read and Write: Allows users to view and enter data in ledgers and balancing or management segment values.

10. (Optional) Choose the Default Ledger button to specify a default ledger for this data access set. The default ledger will automatically default in all windows that provide a Ledger field.

11. Save your work. The General Ledger Accounting Setup Program will be submitted. Note the Request ID and ensure this program completes successfully.

Close the form to create and update a Data Access Set.

Once saved, you cannot delete the data access set. Ledgers and ledger sets can be added or removed from the data access set.

If you need to change the segment value or privilege for a ledger or ledger set in the Segment Values region, you must first delete the ledger or ledger set and then add it back with the preferred segment value or privilege.

You can use the Data Access Set Listing report to review the details of your data access sets.

Note: Before you can use a system-generated or user-defined data access set for General Ledger processing, you must have your System Administrator assign it to the profile option GL: Data Access Set at the General Ledger Application, or Responsibility level. This profile option controls the ledgers that can be accessed by Oracle General Ledger.

If using Oracle Subledgers, you must assign a ledger to the GL Ledger Name profile option to indicate the ledger to use for your subledger applications. The ledger specified is automatically assigned to the GL: Data Access Set profile option, but you can override it. If you want to access more than one ledger for Oracle General Ledger processes, assign a data access set to the GL: Data Access Set profile option. This data access set should include the same ledger used by your Oracle Subledgers so you can view subledger data transferred to General Ledger.

Definition Access Sets

Definition Access Sets are an optional security feature that allow you to secure shared General Ledger definitions such as MassAllocations, Recurring Journal Formulas, and Financial Statement Generator (FSG) components. Definition Access Sets allow you to:

- Assign a user or group of users access to specific definitions.
- Specify what actions can be performed on secured definitions for a user or group of users.

For example, you can secure FSG reports to allow some users to modify the report definition, other users to only view the report definition, while other users can modify, view, and submit the report.

To use Definition Access Set security you:

1. Create a Definition Access Set.
2. Assign it to one or more responsibilities.
3. Create a definition.
4. Secure the definition in its respective window and assign it to a Definition Access Set with the proper privileges.

Access Privileges

You can control who has access to definitions by assigning them to Definition Access Sets with one or more of the following privileges:

- **Use:** Enables a user to use a definition in a process or report, such as FSG Report components, Recurring Journal, and MassAllocation definitions. It also enables a user to use the definition to create another definition, such as using a Recurring Journal to create an AutoAllocation Set or using a FSG Report component to create a FSG report.

If a user only has Use access to a definition, that user cannot view or modify the definition. For example, if a user only has Use access to a MassAllocation definition, that user can generate journals using the MassAllocation in the Generate MassAllocation Journals window, but she cannot view or modify the definition in the Define MassAllocation window.

- **View:** Enables a user to view a definition.

If a user only has View access to a definition, that user cannot use or modify the definition. If AutoCopy is available as a function for that particular definition, the user will be able to use AutoCopy to create a copy of the definition. This allows the

user to create a definition based on an existing definition without changing the original.

- **Modify:** Enables a user to View and Modify a definition. Modify access automatically includes View access.

If a user only has Modify access to a definition, that user cannot use the definition.

Note: The actions permitted by Use, View, and Modify access vary by definition. Table 1–21 specifies Use, View, and Modify access in the context of each definition that can be secured in General Ledger.

Definition Access Sets and Responsibilities

One or more Definition Access Sets can be assigned to one or more responsibilities. If a user has multiple responsibilities assigned with multiple Definition Access Sets that secure the same definition, she will obtain the aggregate effect of all the privileges for that definition. One or more Definition Access Sets can be assigned to one or more responsibilities. If a user has multiple responsibilities assigned with multiple Definition Access Sets that secure the same definition, she will obtain the aggregate effect of all the privileges for that definition.

Example

Consider the following:

Responsibility	Definition Access Set	Report Definition Secured	Privilege
GL Budget User	Report Viewers	Balance Sheet	View
GL Report User	Report Users	Balance Sheet	Use
GL Manager	Reporting All	Balance Sheet	Modify

This combination of responsibilities and Definition Access Sets allow any single responsibility to give her View, Use, and Modify access to the Balance Sheet FSG report.

When a definition is secured, it is automatically assigned to the Definition Access Set called Super User Definition Access Set that has full privileges; Use, View, and Modify access to all secured definitions. Anyone with access to the Definition Access Set window can query the Super User Definition Access Set to view all secured definitions. You can assign the Super User Definition Access Set to any responsibility to grant unlimited access to all secured definitions. The Super User Definition Access Set is intended for use by the System Administrator for maintenance purposes.

Note: Only Definition Access Sets assigned to your responsibilities can be assigned to a definition. If you need to create a definition and assign it to users beyond your Definition Access Sets, you must ask the Super User or someone with broader privileges to do so.

Definition Access Set Reports

You can view Definition Access Sets and a list of secured definitions using one of the following reports that can be submitted from the Submit Request window:

- **Definition Access Set Listing:** This report lists all of the definitions and their privileges that have been assigned to a specific Definition Access Set.
- **Definition Access by User:** This report lists the secured definitions and their privileges that have been assigned to Definition Access Sets for a specific user.

Defining Definition Access Sets

To create a Definition Access Set, perform the following steps.

To create a Definition Access Set:

1. Navigate to the Definition Access Set window.
2. Enter a Name and Description. You cannot modify or delete the Name once it is saved.

Tip: You can initially create a Definition Access Set that has no associated definitions. While subsequently creating a definition, you can secure it by choosing the Definition Access Set from the List of Values in the Definition's Assign window.

Tip: For ease of maintenance, consider a naming convention for your Definition Access Sets that group similar definitions together. For example, you can create a Definition Access Set that groups similar definitions together, such as all of your FSG components. Alternatively, you can create definition access sets that group definitions by privileges, such as Use, View, and Modify privileges. Because you can have an unlimited number of Definition Access Sets assigned to a responsibility, a good naming convention prevents confusion as you secure more definitions in the future.

3. (Optional) From the Definitions region, you can add definitions to the Definition

Access Set. To do so, choose a Definition Type and Name from the List of Values. Only definitions that have been secured with the Enable Security checkbox checked in the definition window will be available.

4. Assign one or more privileges to the definition:

Use: The definition can be used.

View: The definition can be viewed.

Modify: The definition can be viewed and modified. View defaults automatically.

See Table 1–21 for more information on Use, View, and Modify access.

5. Repeat steps 3 and 4 to add more definitions to the Definition Access Set.
6. Save your work.
7. Navigate to the Definition Access Set Assignments window to assign a Definition Access Set to a Responsibility.
8. Select a General Ledger Responsibility that will be assigned to the Definition Access Set .
9. In the Assignments region, choose one or more Definition Access Sets to assign.

Note: The definition access sets you assign will appear in the list of values in the Assign window when securing each definition in their respective definition window.

10. (Optional) Enable the AutoAssign checkbox to automatically have definitions created by responsibility assigned to the Definition Access Set. If you enable AutoAssign, you must choose default privileges for those responsibilities. Specify one or more AutoAssign Privileges for the Definition Access Set: your choices are Use, View, and Modify.

Note: You will be able to override the privileges when securing the individual definitions if you have the Assign Access button available in the respective definition window.

If the Assign Access function has been excluded for this definition from your responsibility, the button will not appear in the respective definition window.

The following table lists General Ledger definitions that can be secured and explains what Use, View, and Modify access mean for each definition.

General Ledger Definitions

Definition	Use Access	View Access	Modify Access (with View Access)
Accounting Calendar	N/A	View calendars in the Accounting Calendar window.	Modify calendars.
AutoAllocation	Generate and Schedule AutoAllocation Sets.	View AutoAllocations in the AutoAllocation Workbench window.	Modify AutoAllocationSets.
AutoPost Criteria Set	Generate or schedule AutoPost Criteria Sets.	View AutoPost Criteria Sets in the AutoPost Criteria Sets window.	Modify AutoPost Criteria Sets.
Budget Formula	Calculate Budget Amounts from the Calculate Budget Amounts window. Calculate/schedule Budget Amounts from the Define Budget Formula window if combined with View privilege.	View the Budget Formula in the Define Budget Formula Window.	Modify Budget Formulas.
Budget Organization	Use Budget Organizations when entering budget amounts or journals.	View Budget Organizations in the Define Budget Organization window.	Modify Budget Organizations.
Chart of Accounts Mapping	Assign the mapping to Consolidations.	View mappings in the Chart of Accounts Mapping window.	Modify Mappings.

Definition	Use Access	View Access	Modify Access (with View Access)
Consolidation Definition	Use Consolidation definitions in the Consolidation Transfer window. Assign Consolidation Definitions to Consolidation Sets.	View Consolidation definitions in the Consolidation Definition window that can also be accessed from the Consolidation Sets window.	Modify Consolidation definitions in the Consolidation Definition window that can also be accessed from the Consolidation Set window
Consolidation Sets	Use Consolidation Sets in the Transfer Consolidation DataSet window.	View Consolidation Sets in the Consolidation Set window.	Modify Consolidation Sets.
Elimination Sets	Generate Elimination Sets.	View Elimination Sets in the Elimination Sets window.	Modify Elimination Sets.
FSG Report	Submit FSG reports regardless of access to FSG components. Assign FSG Reports to a Report Set.	View FSG Reports in the Define Financial Reports window.	Modify FSG reports
FSG Report Components	Assign FSG components to a FSG Report.	View FSG components in their respective definition windows.	Modify FSG components in their respective definition windows.
FSG Report Set	Submit the Report Set regardless of the privileges to the reports in the set.	View the Report Set definition in the Financial Report Set window.	Modify Report Sets.
Journal Reversal Criteria (AutoReversal)	N/A	View Journal Reversal Criteria in the Reversal Criteria window.	Modify Journal Reversal Criteria.

Definition	Use Access	View Access	Modify Access (with View Access)
Ledger Set	Use or assign Ledger Sets to Data Access Sets or another Ledger Set.	View Ledger Sets in the Ledger Set window.	Modify Ledger Sets.
MassAllocation	Generate MassAllocations and assign them to AutoAllocation Sets. If combined with the View privilege, you can generate/schedule MassAllocations from the Define MassAllocation window.	View MassAllocations in the Define MassAllocation window.	Modify MassAllocations.
MassBudget	Generate/schedule MassBudgets and assign them to AutoAllocation Sets. If combined with the View privilege, you can generate/schedule MassBudgets from the Define MassBudget window.	View MassBudgets in the Define MassBudget window.	Modify MassBudgets.
Rate Type	Use or assign the rate type when entering journals, defining MassAllocations, or running Revaluations.	View Rate Type in the Conversion Rate Types window. View rates associated with Rate Types in the Daily Rates window.	Modify Rate Types. Create, update, and delete rates associated with the Rate Types in the Daily Rates window.

Definition	Use Access	View Access	Modify Access (with View Access)
Recurring Journal	Generate Recurring Journals and assign them to AutoAllocation Sets. If combined with the View privilege, you can generate/schedule Recurring Journals from the Define Recurring Journal window.	View Recurring Journals in the Define Recurring Journal window.	Modify Recurring Journals.
Revaluation	Generate Revaluations and assign them to Request Sets.	View Revaluations in the Define Revaluation window.	Modify Revaluations.
Transaction Calendar	N/A	View Transaction Calendars in the Transaction Calendar window.	Modify Transaction Calendars.

Securing Definitions

Caution: Once a definition is secured, use Function Security to prevent a user with Modify access from modifying the privileges for a definition. For more information, refer to Modifying Definition Privileges, page 1-137.

Definitions are secured in their respective windows. For example, you secure Row Sets in the Row Sets window. Once a definition is secured, you can assign the definition to other Definition Access Sets using the Definition Access Set window.

Prerequisite

- Create one or more Definition Access Sets and assign one or more of your responsibilities to them.

To secure a definition:

1. Navigate to a definition window, such as, the Accounting Calendar or AutoPost Criteria Sets window.

See Table 1–21 for a list of all definitions that can be secured using Definition Access Sets.

2. Check the Enable Security checkbox. Definition Access Sets that have been marked as AutoAssign for this responsibility are automatically assigned.
3. Choose the Assign Access button to open the Assign window for that definition. Assign this definition to one or more pre–defined Definition Access Sets.

See: Definition Access Sets, page 1-130

Note: You must assign at least one Definition Access Set to this definition.

Note: If the Assign Access function has been excluded for this definition and responsibility in the Responsibilities window, the Assign Access button is not displayed. Any definition access sets that have been marked as AutoAssign for this responsibility are automatically assigned. See your System Administrator for more information on Function Security.

4. Specify the privileges you want to assign to each Definition Access Set.

If you choose to AutoAssign a Definition Access Set, the Definition Access Set and its privileges are automatically assigned to the definition once you check the Enable Security checkbox in the definition window.

You can always remove the default Definition Access Sets assigned or modify the privileges for the Definition Access Sets. You can include any additional Definition Access Set by choosing from the List of Values. Adjust the privileges as necessary.

The actions for the buttons at the bottom of the definition's Assign window are as follows:

- **Clear Record:** Removes the selected Definition Access Set assignment that has not been saved from your definition.
- **Delete Record:** Deletes the selected Definition Access Set assignment that has been previously saved from your definition.
- **OK:** Saves the settings in this window.

- **Cancel:** Cancels the settings in this window.
5. Choose OK in the Assign window.
 6. Save your work

General Ledger submits a concurrent request called Compile Definition Access Sets to add the definition to the Definition Access Sets. Your definition will not be secured until the concurrent request completes successfully.

To remove security on a definition:

You can remove security on a definition at any time by disabling the Enable Security checkbox. This removes all Definition Access Sets assigned to the definition.

Modifying Definition Privileges

You must have Modify privilege for a definition to change the privileges on a definition. There are two ways to modify Definition Access Set Privileges:

Query the definition in the respective definition window. Then select the Assign Access button to open the Assign window and change the privileges.

OR

Query the Definition Access Set in the Definition Access Sets window. Then Locate the definition type and name and modify the privileges.

Note: Use Function Security to prevent a user with Modify access from modifying the privileges for a definition. For example, if a user has Modify privileges on an FSG Report, the user can potentially change his privileges to include Use access. To prevent this, exclude the Assign Access function for those definitions from the user's responsibility.

The Assign Access function is called Secure <Object Name>. For example, if the Secure Financial Report function is excluded from a responsibility, then the Assign Access button is hidden from the Define Financial Report window for that responsibility.

Setting Up Journal Approval

You can set up journal approval using the following features:

1. Oracle General Ledger Journal Approval, page 1-138
2. Oracle General Ledger Journal Approvals Integration with Oracle Approvals Management and Oracle Workflow, page 1-140

Oracle General Ledger Journal Approval

Use General Ledger's Journal Approval feature to ensure that journal entries and batches are approved by appropriate individuals before the journals can be posted to your account balances.

Journal Approval uses Oracle Workflow to control and monitor the approval process, sending notifications to journal batch preparers and approvers when needed. Some of the Journal Approval components can be customized to meet your organization's specific needs. See: Journal Approval, *Oracle General Ledger User's Guide*.

Before you use Journal Approval, you must enable journal approval for your ledgers. You must also set up your journal sources to use journal approval. Finally, you must create an approval hierarchy and define your approver authorization limits.

You can also restrict who a journal approval request is reassigned to by running a program that restricts the assignee list of values. The restricted list of values includes valid employees or contract (contingent) workers who are application users with journal authorization limits. Otherwise, the assignee list of values lists employees or contract (contingent) workers, whether they have or do not have journal authorization limits or they are or are not associated with application users.

Prerequisites

Before you use Journal Approval, you or your system administrator must:

- Set up Oracle Workflow. See: Setting Up Oracle Workflow, *Oracle Workflow Guide*
- Set the two profile options Journals: Allow Preparer Approval and Journals: Find Approver Method. See: Setting General Ledger Profile Options, *Oracle General Ledger Reference Guide*.
- Configure the GL Journal Approval Process in Oracle Workflow Builder. Specifically, you must set the performer for the Notify System Administrator - No Approver and Notify System Administrator - No Approver Manager activities. Also, you can change the default settings for Request Approval From Approver timeout and the Reached Manager Notification Resend Limit. See: Journal Approval, *Oracle General Ledger User's Guide*.
- Enable Journal Approval for your ledger in Accounting Setup Manager.

To enable Journal Approval for your ledgers:

When you define your ledgers using Accounting Setup Manager, mark the Enable Journal Approval check box on the Ledgers page.

If you use reporting currencies (journal or subledger level), you can enable Journal Approval for your reporting currencies in Accounting Setup Manager.

See: Defining Ledgers, page 1-110

See: Creating Accounting Setups.

To specify journal sources that require journal approval:

On the Journal Sources window, mark the Require Journal Approval check box for each journal source that should be subject to approval.

When a journal entry or batch is created using one of these journal sources, the journal must be approved before it can be posted.

See: Defining Journal Sources, page 1-156

To create an approval hierarchy:

Use the Enter Person window in Oracle General Ledger to enter all of your employees or contract (contingent) workers who are involved in preparing and approving journal entries and batches.

See: Entering a New Employee, *Oracle Human Resources User's Guide*

When you enter an employee or contract (contingent) worker, you also enter the supervisor or manager name. The supervisor is the default next approver for journal entries and batches. Likewise, the supervisor's manager is the next approver after the supervisor.

To define authorization limits:

1. Navigate to the Journal Authorization Limits window.
2. Enter the ledger in the Ledger column. You can select a ledger in your data access set if you have read/write access to at least one or more balancing segment values or management segment values in the ledger.

Note: If you use reporting currencies (journal or subledger level), you can enter a reporting currency in the Ledger column if you have read/write access to one or more balancing segment values or management segment values in the reporting currency.

3. The Currency column defaults to the currency of the ledger or reporting currency you entered in the previous step.
4. Enter the Employee name, or select it from the list of values.
5. Enter the amount of the employee's Authorization Limit.
6. Repeat the previous two steps for each employee for whom you want to define authorization limits.
7. Save your work.

To query authorization limits:

1. Navigate to the Journal Authorization Limits window.
2. In the Find Journal Authorization Limits window, enter the ledger and or employee you are trying to find.

Note: You can select a ledger in your data access set if you have read access to at least one or more balancing segment values or management segment values in the ledger.

Note: If you use reporting currencies (journal or subledger level), you can enter a reporting currency in the Ledger field if you have read access to one or more balancing segment values or management segment values in the reporting currency.

To restrict the assignee list of values for journal approval requests:

To restrict the assignee list of values for journal approval requests, perform the following steps.

1. From the Submit Requests window, run the program named Program - Maintain Authorized Users for Journal Approval Reassignment to restrict the assignee list of values to valid application users who have journal authorization limits.
2. Run this program as frequently as needed to include any changes to employees' statuses, application user effective dates, or to journal authorization limits.

If any of the preceding changes occur, run this program to update the assignee list of values to reflect the changes for journal approval requests.

To restrict the notification reassignment approval list:

To restrict the notification reassignment list to employees or contract (contingent) workers who have journal authorization limits in your Oracle Applications instance, run the program Maintain Authorized Users for Journal Approval Reassignment. Run the program as needed to implement changes to employees' or contract (contingent) workers' statuses, application users, or journal authorization limits. The reassignment list will display active employees or contract (contingent) workers associated with valid application users who have journal authorization limits.

Oracle General Ledger Journal Approvals Integration with Oracle Approvals Management and Oracle Workflow

You can also set up journal approval by integrating with Oracle Approvals

Management and Oracle Workflow. With this feature you can configure flexible rules for the routing of journals to one or more approvers, sequentially or in parallel, as well as tracking the approval status for the journals processed.

To set up Oracle General journal approvals integration with Oracle Approvals Management and Oracle Workflow:

1. Install the Oracle Workflow Builder client component program to modify the Journal Approval Workflow.
 1. Set up approvers to receive notifications. You can set up Oracle Workflow Notification Mailer so the Journal Approval Workflow Program uses e-mail, and your system administrator can grant approvers access to view journal approval notifications from the Oracle Workflow Notification Worklist web page.
 2. Complete additional Oracle Workflow setup steps. Specify the timeout value, the time period in which an approver needs to respond before sending a reminder notification or escalating the request to the approver's manager.
 3. (Optional) Modify the Journal Approval Workflow. For example, you can modify the message text that appears on your notifications.
 4. Set up a designated person who receives notification of workflow errors through the Oracle Workflow Default Error Process. Oracle recommends that the person who receives Oracle Approvals Management error notifications should also receive Oracle Workflow process error notifications.

Tip: If you are an existing Oracle E-Business Suite customer who has already integrated another Oracle E-Business Suite product with Oracle Approvals Management and Oracle Workflow, such as the Oracle Payables invoice approval process, you may already have installed the Oracle Workflow Builder client component program and Oracle Approvals Management. You will not need perform this installation again.

Setting Up Oracle Workflow, *Oracle Workflow Guide*

2. Install and set up Oracle Approvals Management (AME).

Tip: If you are an existing Oracle E-Business Suite customer who has already integrated another Oracle E-Business Suite product with Oracle Approvals Management and Oracle Workflow, such as the Oracle Payables invoice approval process, you may already have installed the Oracle Workflow Builder client component

program and Oracle Approvals Management. You will not need perform this installation again.

3. Enable Journal Approval for relevant ledgers.

The check box for Enable Journal Approval must be selected in the Journal Processing region of the Ledger setup within the Accounting Setup Manager for each ledger that requires the journal approvals process.

4. Two new profile options must be reviewed and set for the Oracle General Ledger (GL) Journal Approvals Management Integration with Oracle Approvals Management and Oracle Workflow, as follows:

- GL: Use Approval Management (AME) for journal approval - Determines if Oracle Workflow will follow the existing process of approving journals using the Supervisor hierarchy and Employee Limits form, or if it will use the new integration with Oracle Approvals Management and Oracle Workflow.

Important: Set this profile option to Yes at Site level to use Oracle Approval Management (AME) and Oracle Workflow for journal approval in Oracle General Ledger.

- GL: Number of journal lines to display in AME journal approval notification - Determines the maximum number of lines to display in the journal approvals notification, which is sent to the journal approvers. The default value is set to 5. If the journal contains more than five lines, a hyperlink enables the approvers to access the full journal in Oracle General Ledger.

Tip: It is recommended that you do not set the value to higher than 10 due to a limitation with the file size of the workflow approval notification.

5. Create a HR Supervisor Approval Hierarchy Use the Enter Person window in Oracle General Ledger to enter all of your employees who are involved in preparing and approving journal entries and batches.

For more information see the Entering a New Employee section of the *Oracle Human Resources Management System User's Guide*

When you enter an employee, you will also enter the employee's supervisor or manager name. The supervisor is the default next approver for journal entries and batches. Likewise, the supervisor's manager is the next approver after the supervisor.

6. Create and maintain approval limits. This is an optional step but is useful for

subsequent AME definitions.

Navigate to the Journal Authorization Limits form within the Oracle General Ledger Super User responsibility to create and maintain the approver limits:

1. Enter the ledger in the Ledger column. You can select a ledger in your data access set if you have read/write access to at least one or more balancing segment values or management segment values in the ledger.

Note: If you use reporting currencies (journal or subledger level), you can enter a reporting currency in the Ledger column if you have read and write access to one or more balancing segment values or management segment values in the reporting currency.

The Currency column defaults to the currency of the ledger or reporting currency that you entered in the previous step.

2. Enter the Employee name, or select it from the list of values.
 3. Enter the amount of the employee authorization limit. Repeat the previous two steps for each employee for whom you want to define authorization limits.
 4. Save.
7. Configure Oracle Approvals Management (AME) Rules.

Note: Use the Approvals Management Business Analyst responsibility

1. A prerequisite to using the Approvals Management Business Analyst responsibility and the Business Analyst Dashboard is to first add roles to the AME Setup user through the User Management responsibility, and to grant data access to the AME Setup user through the Functional Administrator responsibility. Without the proper roles and data access the AME Setup user will not be able to define AME rules.
2. In AME, you will define the rules that the system uses to determine the appropriate approvers for a journal batch or journal in Oracle General Ledger.
3. Navigate to the Business Analyst Dashboard and click on the setup for GL Journal Approval transaction type.
4. Navigate to the Conditions tab and set up a new condition to enable the rule for AME.

5. After all the conditions are set, click on the Rules tab and create rules to check for AME Approval.
6. Set up the Action type and define Voting Method, which will be followed by the Oracle Workflow integration with Oracle Approvals Management for journal approval in Oracle General Ledger.
7. Action Types can be set up at Supervisor level or Approval Group chain of authority. To set up Dynamic Approvers, the Action type should be set as Approval Group chain of Authority and Voting Method should be set. To set up a normal HR Supervisor Hierarchy level approval, select the Action Type as Supervisory Level and set the Voting method.
8. If the approver level needs to be Dynamic or Static, then you must create a new Approver Group and select the Usage Type field as Static or Dynamic.
 1. If the usage type selected is Dynamic, then you must write a SQL Query to derive the approver list. For more details on how to use the AME Attributes refer *Oracle Approvals Management Implementation Guide*.
 2. If the usage type selected is Static, then the Approver Type must be updated.
9. Test your AME rules for Oracle General Ledger journals.
 1. To ensure that the AME rules satisfy the conditions and actions you can create a journal and then test it using the AME Test Workbench before submitting the journal for approval. It is advisable to test every time AME rules are modified or for debugging of journals.
 2. If the submitted journal satisfies AME rules, it will follow the approval hierarchy in the AME setup for the Action Type.
 3. In case the journals do not satisfy any of the AME rules, and complete in error, use the Test Workbench to troubleshoot.

Implementation Considerations

AME Rules

Typically a system administrator works with the finance department to configure and maintain the approval rules utilizing the Approvals Management Business Analyst responsibility. You can use conditions to identify values and value ranges for the attributes. Conditions can be created using the AME Business Analyst Dashboard by selecting the Conditions link. From the dashboard you can also create rules by selecting the Rules link.

Business Rules and Logic

The following business rules and logic apply to the journal approvals process in Oracle General Ledger when integrating with Oracle Approvals Management and Oracle Workflow:

- Enable Journal Approval should be checked in the Accounting Setup Manager for the ledger.
- Journal Approval in Oracle General Ledger is required when a journal is input or reversed using the Journals page in Oracle General Ledger, but only when the journal source is set to Require Journal Approval.
- Batches may consist of multiple journals with many lines. A batch may have two journals, where the first journal relates to ledger A, and the second journal relates to ledger B. For each of the journals a different approver may be required. You can define the rules to track a journal batch as approved only after approvals are received from all approvers for all journals (related to different ledgers) in the batch.
- The approval list generation is controlled through AME. This enables you to modify the conditions for the business rules. Those rules are also available for use by other subscribing applications to AME.
- When an approver receives a journal approval notification, the approver reviews the journal details and selects one of the following:
 - Approve
 - Reject
 - Reassign: Delegate authority to another Oracle user
 - Request Information: Request more information from the journal preparer
- The approver is approving or rejecting all relevant lines within a journal. There is no option to approve some journal lines while rejecting other journal lines for a journal. The journal batch is approved after all of the required responses are positive.
- If a journal is rejected, a Rejection Notification is sent to both the preparer and all approvers.
- You must define a business process to handle the subsequent actions after the rejection of journals by approvers.
- Approvers can use the standard vacation rules to route to other approvers in the event of vacation or absence. If a notification times out, then the HR Supervisor Hierarchy is used in the AME rules. In this case the approver's supervisor receives the notifications to approve or reject. If the supervisor approves, then the journal is

approved after all other approvers approve and if supervisor rejects then the journal is rejected.

- When no approver can be found for a journal in Oracle General Ledger, the workflow system administrator and the preparer receives a notification. The notification to the preparer is for information purposes only.
- The AME or workflow system administrator and preparer receive notifications on two occasions, when the AME Rule:
 - setup is invalid.
 - has no approvers.
- After the system administrator fixes the AME rule, and the administrator resubmits the journal batch for approval, then the preparer receives a notification that the problem is fixed and that the journal is resubmitted for approval.
- Journals created from previously approved journals with an auto-reversal element, do not require approval again, because the original journal was already approved.
- Journals that are generated using an auto-reversal process occur at the start of accounting periods.
- Time-outs within Oracle Workflow are set to a 7 day default.

Monitor Exceptions

The Workflow system administrator should monitor the Journal Batch workflow type for workflows that end in an error state.

Action History

There is an history table named `GL_WF_ACTION_HISTORY` that tracks approver responses to the Oracle Workflow journal approval notifications. You can use table to create custom reports to audit the current status of journals approvals.

Oracle General Ledger Attributes Available for AME Rules Configuration

The following Oracle General Ledger attributes are available in Oracle Approvals Management to build your approval rules:

Item Class - Header (Matches with Journal Batch Level Attributes)

Attribute Name	Description
-----------------------	--------------------

BATCH_PERIOD	Specify separate approval chain for journals submitted for instance in adjustment periods or for instance for journals submitted in the final period of the financial year.
BATCH_DEBIT_RUNNING_TOTAL	Specify separate approver groups depending on the journal batch debit amount. For instance, if the journal batch debit amount is greater than 1 million USD then request for approval should go to senior management group.
BATCH_CREDIT_RUNNING_TOTAL	Specify separate approver groups depending on the journal batch credit amount. For instance if the journal batch credit amount greater than 1 million USD then request for approval should go to senior management group.
BATCH_ATTRIBUTE1	Used for any specific client business requirement, information for which is captured in journal batch Descriptive Flexfield segment 1.
BATCH_ATTRIBUTE2	Used for any specific client business requirement, information that is captured in journal batch Descriptive Flexfield segment 2.
BATCH_ATTRIBUTE3	Used for any specific client business requirement, information that is captured in journal batch Descriptive Flexfield segment 3.
BATCH_ATTRIBUTE4	Used for any specific client business requirement, information that is captured in journal batch Descriptive Flexfield segment 4.
BATCH_ATTRIBUTE5	Used for any specific client business requirement, information that is captured in journal batch Descriptive Flexfield segment 5.
BATCH_ATTRIBUTE6	Used for any specific client business requirement, information that is captured in journal batch Descriptive Flexfield segment 6.

BATCH_ATTRIBUTE7	Used for any specific client business requirement, information that is captured in journal batch Descriptive Flexfield segment 7.
BATCH_ATTRIBUTE8	Used for any specific client business requirement, information that is captured in journal batch Descriptive Flexfield segment 8.
BATCH_ATTRIBUTE9	Used for any specific client business requirement, information that is captured in journal batch Descriptive Flexfield segment 9.
BATCH_ATTRIBUTE10	Used for any specific client business requirement, information that is captured in journal batch Descriptive Flexfield segment 10.
FISCAL_YEAR	Used along with combination of other attributes, in order to create conditions to select approvers.
PERIOD_START_DATE	Select a separate approver groups based on journal dates. For instance, if the date falls during the last week of the period then approver group to be separate from normal dates.
PERIOD_END_DATE	Select a separate approver groups based on journal dates. For instance, if the date falls during the last week of the period then approver group to be separate from normal dates.
JOURNAL_TYPE	Approve journals based on the journal types, such as Actual, Budget, and Encumbrance.

Item Class - Line (Matches with Journal Header Level Attributes)

Attribute Name	Description
-----------------------	--------------------

JOURNAL_CATEGORY	Identify approval groups based on journal categories. JOURNAL_SOURCE Used for identifying approval groups based on journal source.
JOURNAL_DATE	Identify approval groups based on journal date.
JOURNAL_HEADER_DEBIT_RUNNING_TOTAL	Specify separate approver groups depending on the journal header debit amount. For instance, if the journal header debit amount is greater than 1 million then request for approval should go to senior management group.
JOURNAL_HEADER_CREDIT_RUNNING_TOTAL	Specify separate approver groups depending on the journal header debit amount. For instance, if the journal header debit amount is greater than 1 million then request for approval should go to senior management group.
JOURNAL_HEADER_ATTRIBUTE1	Used for any specific client business requirement, information that is captured in journal header Descriptive Flexfield segment 1.
JOURNAL_HEADER_ATTRIBUTE2	Used for any specific client business requirement, information that is captured in journal header Descriptive Flexfield segment 2.
JOURNAL_HEADER_ATTRIBUTE3	Used for any specific client business requirement, information that is captured in journal header Descriptive Flexfield segment 3.
JOURNAL_HEADER_ATTRIBUTE4	Used for any specific client business requirement, information that is captured in journal header Descriptive Flexfield segment 4.
JOURNAL_HEADER_ATTRIBUTE5	Used for any specific client business requirement, information that is captured in journal header Descriptive Flexfield segment 5.

JOURNAL_HEADER_ATTRIBUTE6	Used for any specific client business requirement, information that is captured in journal header Descriptive Flexfield segment 6.
JOURNAL_HEADER_ATTRIBUTE7	Used for any specific client business requirement, information that is captured in journal header Descriptive Flexfield segment 7.
JOURNAL_HEADER_ATTRIBUTE8	Used for any specific client business requirement, information that is captured in journal header Descriptive Flexfield segment 8.
JOURNAL_HEADER_ATTRIBUTE9	Used for any specific client business requirement, information that is captured in journal header Descriptive Flexfield segment 9.
JOURNAL_HEADER_ATTRIBUTE10	Used for any specific client business requirement, information that is captured in journal header Descriptive Flexfield segment 10.
LEDGER_NAME	Used to select approver groups based on the Ledger assigned to the journal.
LEDGER_CURRENCY	Used to select approver groups based on the Ledger currency assigned to the journal.
LEDGER_CURRENCY_TYPE	Used to select approver groups based on the Ledger Currency Type assigned to the journal such as the Journal is for Statistical or Entered currency.

Item Class - Distribution (Matches with Journal Line Level Attributes)

Attribute Name	Description
-----------------------	--------------------

JOURNAL_LINE_BSV	Create AME conditions based on balancing segment value, such as depending on Balancing Segment (Qualifier) values forward the journal to a specific approver group.
JOURNAL_LINE_COST_CENTRE	Create AME conditions based on Cost Centre segment value, such as depending on Cost Centre Segment (Qualifier) values forward the journal to specific approver group.
JOURNAL_LINE_NATURAL_ACCOUNT	Create AME conditions based on Natural Account segment value, i.e. depending on Natural Account Segment (Qualifier) Values forward the journal to specific approver group.
JOURNAL_LINE_INTERCOMPANY	Create AME conditions based on Intercompany segment value, such as depending on Intercompany Segment (Qualifier) Values forward the journal to specific approver group.
JOURNAL_LINE_MANAGEMENT_SEG	Create AME conditions based on Management segment value, such as depending on Management Segment (Qualifier) Values forward the journal to specific approver group.
JOURNAL_LINE_SECONDARY_TRACKING	Create AME conditions based on Secondary Tracking segment value, such as depending on Secondary Tracking Segment (Qualifier) Values forward the journal to specific approver group.
JOURNAL_LINE_ATTRIBUTE1	Used for any specific client business requirement, information that is captured in journal line Descriptive Flexfield segment 1.
JOURNAL_LINE_ATTRIBUTE2	Used for any specific client business requirement, information that is captured in journal line Descriptive Flexfield segment 2.
JOURNAL_LINE_ATTRIBUTE3	Used for any specific client business requirement, information that is captured in journal line Descriptive Flexfield segment 3.

JOURNAL_LINE_ATTRIBUTE4	Used for any specific client business requirement, information that is captured in journal line Descriptive Flexfield segment 4.
JOURNAL_LINE_ATTRIBUTE5	Used for any specific client business requirement, information that is captured in journal line Descriptive Flexfield segment 5.
JOURNAL_LINE_ATTRIBUTE6	Used for any specific client business requirement, information that is captured in journal line Descriptive Flexfield segment 6.
JOURNAL_LINE_ATTRIBUTE7	Used for any specific client business requirement, information that is captured in journal line Descriptive Flexfield segment 7.
JOURNAL_LINE_ATTRIBUTE8	Used for any specific client business requirement, information that is captured in journal line Descriptive Flexfield segment 8.
JOURNAL_LINE_ATTRIBUTE9	Used for any specific client business requirement, information that is captured in journal line Descriptive Flexfield segment 9 .
JOURNAL_LINE_ATTRIBUTE10	Used for any specific client business requirement, information that is captured in journal line Descriptive Flexfield segment 10.
JOURNAL_LINE_ATTRIBUTE11	Used for any specific client business requirement, information that is captured in journal line Descriptive Flexfield segment 11.
JOURNAL_LINE_ATTRIBUTE12	Used for any specific client business requirement, information that is captured in journal line Descriptive Flexfield segment 12.
JOURNAL_LINE_ATTRIBUTE13	Used for any specific client business requirement, information that is captured in journal line Descriptive Flexfield segment 13.
JOURNAL_LINE_ATTRIBUTE14	Used for any specific client business requirement, information that is captured in journal line Descriptive Flexfield segment 14.

JOURNAL_LINE_ATTRIBUTE15	Used for any specific client business requirement, information that is captured in journal line Descriptive Flexfield segment 15.
JOURNAL_LINE_ATTRIBUTE16	Used for any specific client business requirement, information that is captured in journal line Descriptive Flexfield segment 16.
JOURNAL_LINE_ATTRIBUTE17	Used for any specific client business requirement, information that is captured in journal line Descriptive Flexfield segment 17.
JOURNAL_LINE_ATTRIBUTE18	Used for any specific client business requirement, information that is captured in journal line Descriptive Flexfield segment 18.
JOURNAL_LINE_ATTRIBUTE19	Used for any specific client business requirement, information that is captured in journal line Descriptive Flexfield segment 19.
JOURNAL_LINE_ATTRIBUTE20	Used for any specific client business requirement, information that is captured in journal line Descriptive Flexfield segment 20.
GL_JOURNAL_LINE_DEBIT_AMOUNT	Used to specify separate approver groups depending on the journal lines debit amount. For instance, if the journal line debit amount is greater than ten thousand USD, then approver should go to Accountants/Supervisors.
GL_JOURNAL_LINE_CREDIT_AMOUNT	Specify separate approver groups depending on the journal lines credit amount. For instance, if the journal line credit amount is greater than ten thousand USD, then approver should go to Accountants/Supervisors.

Tip: When you define approval rules and conditions in Oracle Approvals Management using any of the preceding attributes you must consider whether attributes at journal line level will clash with any other attributes you might use for rules definitions at a higher level such as at journal header or journal batch level.

Action History Table

The action history table tracks the journal status based on the responses the approvers give to the Oracle Workflow routed journal approval notifications. Refer to the Implementation Considerations, page 1-144 for further information about the Action History table.

Action History Table

Column Name	Data Type	Column Description
OBJECT_TYPE_CODE Name of the object.	VARCHAR2	GLJOURNAL for Journal Batch Approval.
OBJECT_ID	NUMBER	Journal batch Id.
SEQUENCE_NUM	NUMBER	Sequence number of the record.
WF_ITEM_TYPE	VARCHAR2	Workflow Item type of parent process GLBATCH for 'Journal Batch Approval.
WF_ITEM_KEY	VARCHAR2	Workflow Item key of parent process.
WF_PREPARER_NAME	VARCHAR2	Name of the preparer who submitted the journal batch for approval.
WF_APPROVER_NAME	VARCHAR2	Name of the approver who responded to the journal batch approval notification.
LAST_UPDATE_DATE	DATE	Last update date for the notification.
LAST_UPDATED_BY	NUMBER	Last updated by for the notification.
CREATION_DATE	DATE	Creation date for the notification.

CREATED_BY	NUMBER	Created by for the notification.
ACTION_CODE	VARCHAR2	Current status for the notification.
ACTION_DATE	DATE	Date when the action was updated.
EMPLOYEE_ID	NUMBER	Approver to whom the notification is sent.
NOTE	VARCHAR2	Comments from the responder of the notification.
LAST_UPDATE_LOGIN	NUMBER	Last updated logic.
APPROVAL_GROUP_ID	NUMBER	Approval group Id to which the employee_id belongs.

Tip: The Action History table tracks the status only for the Oracle General Ledger Integration with Oracle Approvals Management and Oracle Workflow.

Guidance on AME Rules Setup for Oracle General Ledger Journal Approvals

This section provides guidance on Oracle Approvals Management (AME) rules setup for the Oracle General Ledger Journal Approvals process. You must first complete you the setup steps, page 1-141 previously outlined.

To Create a GL Journal Approval Rule in Oracle Approvals Management:

1. Navigate to Business Analyst Dashboard.
2. Select the GL Journal Approval transaction type and select (I) Setup.
3. Navigate to the Conditions tab to set up a new condition and enable the rule for AME.
4. Select Create to create new AME Conditions and enter details.
5. Select the Action Types tab to create new Actions.
6. Create new Approver Groups to use Static or Dynamic approvers.

If the approver level needs to be Dynamic or Static, then you must create a new approver group and set the Usage Type field as Static or Dynamic. If the usage type selected is:

- Dynamic, then you must write a SQL Query to derive the approver list.
- Static, then the approver type must be updated.

Related Topics

Journal Approval, *Oracle General Ledger User's Guide*

Defining Ledgers, page 1-110

Journal Sources, page 1-156

Entering Employees, *Oracle General Ledger Implementation Guide*

Setting Up General Ledger

Once you have completed your planning and implementation activities, you need to set up General Ledger for your organization's use.

Below are detailed instructions for each of the General Ledger setup steps outlined in the overview section. There are references to other sections of this guide for more detailed instructions and background.

Journal Sources

Journal sources identify the origin of your journal entries. General Ledger supplies a number of predefined journal sources. In addition, you should define at least one journal source for each of your own, non-Oracle feeder systems to help you track imported journal entries.

Defining Journal Sources

For each journal source, you can choose to:

- **Import Journal References:** To import detail reference information for summary journals you import from your Oracle feeder systems. If you choose this option, you can also use the Account Inquiry window to drilldown to subledger transactions, transferred from Oracle subledgers in summary or detail, for a specified source.
- **Freeze Journals:** To freeze the journal source, preventing users from making changes to any unposted journals from that source, or reversing journals for Subledger Accounting journal sources.
- **Require Journal Approval:** To require journals with a specific journal source be

approved by higher management levels before posting. Journal Approval must be enabled for your ledger.

- **Import Using Key:** To use a language-independent and instance-independent key, as specified in the Source Key field. This option allows you to identify a particular journal source and category consistently across all languages and instances.

General Ledger provides predefined journal entry sources, listed in the table below:

Name	Description
AX Inventory	AX Inventory Entry
AX Payables	AX Payables Entry
AX Receivables	AX Receivables Entry
Assets	Fixed Asset System
Average Consolidation	Average Balance Consolidation
Budget Journal	Budget Journal
Carry Forward	Carry Forward Journal Entry
Closing Journal	Closing Journal
Consolidation	Consolidation Transfer
Contract Commitment	Contract Commitment
Conversion	Historical Data Conversion
Elimination	Intercompany Elimination
Encumbrance	Manual Encumbrance Entry
Inflation	Inflation Journal Entry
Inflation Accounting	Inflation Accounting
Intercompany	Intercompany Transactions

Name	Description
Intercompany Allocations	Allocations transferred from Oracle Intercompany
Inventory	Inventory Control System
Lease	Oracle Lease Management
Manual	Manual Journal Entry
Manufacturing	Manufacturing
Marketing	Marketing Online System
MassAllocation	MassAllocation
Move/Merge	Move/Merge
Move/Merge Reversal	Move/Merge Reversal
Other	All other sources
Payables	Accounts Payable System
Payroll	Payroll System
Periodic Inventory	Periodic Inventory Control System
Personnel	Personnel System
Projects	Project Accounting
Property Manager	Property Manager
Public Sector Budget	Public Sector Budget
Purchasing	Purchasing System
Receivables	Accounts Receivable System
Recurring	Recurring Journal Entry

Name	Description
Revaluation	Revaluation Journal Entry
Revenue	Revenue Accounting System
Spreadsheet	Spreadsheet
Statistical	Statistical Journal Entry
Student System	Student System
Transfer	Budget Transfer
Treasury	Treasury

To define a new journal entry source:

1. Navigate to the Journal Sources window.
2. Enter a unique Source, Source Key and Description for your journal entry source. The Source and Source Key can be the same or different. You cannot delete a source name after saving your work.

Note: You can change the source name at any time. For user-defined sources, you can change the source name and source key at any time.

3. Enable/Disable the following check boxes for this journal source:

Import Journal References

Enabled:

- In the Account Inquiry window, you can drilldown to subledger transactions, transferred from subledgers in summary or detail, for this source.
- Journal References will be imported from your feeder systems to maintain a mapping of summarized transactions when you run Journal Import, whether you run Journal Import in summary or detail. This information is stored in the GL_IMPORT_REFERENCES table.

You can request a mapping report from your feeder systems after Journal Import completes. Or, you can write your own report referencing the

GL_IMPORT_REFERENCES table which stores the mapping information.

Disabled:

- In the Account Inquiry window, you cannot drilldown to subledger transactions, transferred from subledgers in summary or detail, for this source.

Warning: Do not disable Import Journal References if you plan to drill down to transactions from the Account Inquiry window. Once you disable Import Journal References, you will not be able to drill down to transactions subsequently imported using that journal source.

Freeze Journals

Choose an option from the list:

- Yes: Journals from this source cannot be changed in the Enter Journals form nor the Journal Correction form. In addition, you cannot reverse journals with Subledger Accounting journal sources that are frozen.
- No: Journals from this source can be changed in both the Enter Journals form and the Journal Correction form. In addition, you can reverse journals with unfrozen Subledger Accounting journal sources.
- Journal Entry Page Only: Journals from this source cannot be changed in the Enter Journals form but can be changed in the Journal Correction form. In addition, you cannot reverse journals with Subledger Accounting journal sources that have this option.

Require Journal Approval

If journal approval is enabled for your ledger and you enter a journal whose journal source requires journal approval, the batch must be approved before it can be posted.

Import Using Key

Enabled:

- If you enable this checkbox, the Journal Import program uses the value entered in the Source Key field, instead of the Source field, when importing journals for a given source.
- The Source Key is a language-independent and instance-independent key that helps you identify a particular journal source and category consistently across all languages and instances.
- You should check the checkbox for custom sources if want to use the Source

Key values instead of the Source values upon importing journals.

Disabled:

- By default, the checkbox is unchecked. The Journal Import program uses the value entered in the Source field when importing journals for a given source.
4. (Average Balance Processing only) From the poplist, select an Effective Date Rule for this journal source:
- **Fail:** Journal Import will reject transactions when the effective date is not a valid business day. No posting takes place.
 - **Leave Alone:** Journal import will accept all transactions regardless of the effective date.
 - **Roll Date:** Journal Import will accept the transaction, but roll the effective date back to the nearest valid business day within the same period. If there is no prior valid business day within the same period, the effective date is rolled forward.

Note: The Effective Date Rule field will not appear unless you have average balance processing enabled for at least one ledger.

5. Save your work.

To review or change an existing journal entry source:

1. Navigate to the Journal Sources window.
2. Query the journal entry source you want to review or change. You can change the Name, Description, Import Journal References setting, Freeze Journals setting, Require Journal Approval, and Import Using Key setting. You can change the Effective Date Rule for any journal source except Average Consolidation.

Warning: Do not disable Import Journal References if you plan to drill down to transactions from the Account Inquiry window. Once you disable Import Journal References, you will not be able to drill down to transactions subsequently imported using that journal source.

3. Save your work.

Related Topics

Integrating General Ledger Using Journal Import, *Oracle General Ledger User's Guide*

Importing Journals, *Oracle General Ledger User's Guide*

Overview of Average Balance Processing, *Oracle General Ledger User's Guide*

Journal Categories

Journal categories help you differentiate journal entries by purpose or type, such as accrual, payments or receipts. When you enter journals, you specify a category.

Defining Journal Categories

You can define intercompany and suspense accounts for specific categories. You can also use document sequences to sequentially number journal entries by category. Journal categories appear in standard reports, such as the General Journals report.

General Ledger provides the predefined journal categories shown in the following table:

Name	Description
Accrual	Month End Accrual Entry
Addition	Addition
Adjustment	Adjusting Journal Entry
Allocation	Allocation
Allowance	Allowance
Application Fee	Application Fee transactions from Admissions
Asset Disposition	Asset Disposition
Balance Sheet Close	Balance Sheet Close
Bank Charges	Bank Charges
Bank Receipts	Bank Receipts

Name	Description
Bills Receivable	Bills Receivable
Budget	Budget
Burden Cost	Burden Cost
Campaigns	Campaigns
Cancellation	Bank Collection Cancellation
Carry Forward	Carry Forward Journal Entry
Chargebacks	Chargebacks
Charges	Charge transactions from Student Finance
CIP Addition	CIP Addition
CIP Adjustment	CIP Adjustment
CIP Reclassification	CIP Reclassification
CIP Retirement	CIP Retirement
CIP Transfer	CIP Transfer
Confirmation	Confirmation
Confirmed	Contract Commitment - Confirmed
Consolidation	Consolidation
Credit Memo Applications	Credit Memo Applications
Credit Memos	Credit Memos
Credits	Credit transactions from Student Finance
Cross Charges	Internal Trading Cross Charges

Name	Description
Cross Currency	Cross Currency
Debit Memos	Debit Memos
Deductions	Deductions
Deferred Depreciation	Deferred Depreciation
Deposits	Deposit transactions from Student Finance
Depreciation	Fixed Asset Depreciation
Depreciation Adjustment	Depreciation Adjustment
Discounts	Discounts
Elimination	Intercompany Elimination
Exchange Gain/Loss	Gain or Loss from Foreign Currency
Freight	Shipping Charges
Headcount	Statistical Entry for Headcount
Income Offset	Income Offset
Income Statement Close	Income Statement Close
Intercompany Allocations	Allocations transferred from Oracle Intercompany
Intercompany Transfer	Intercompany Transfer
Internal Charge	Internal Trading Cross Charge Category
Internal Receipts	Internal Order Receipts of Process Items
Internal Shipments	Internal Order Shipments of Process Items
Inventory	Inventory

Name	Description
Labor Cost	Labor Costs
Loss Provision	Loss Provision
Misc Receipts	Miscellaneous Receipts
Miscellaneous	Miscellaneous
Misc Transaction	Miscellaneous Transaction
Move/Merge	Move/Merge
Move/Merge Reversal	Move/Merge Reversal
MTL	Material Transactions
Other	All other categories
Payments	Cash Disbursements
Payroll	Payroll Distribution Entry
PM Expense	Property Manager Expense
PM Revenue	Property Manager Revenue
Prov Cost Reclass	Provider Cost Reclassification
Provisional	Contract Commitment - Provisional
Purchase Invoices	Accounts Payable Invoices
Purchases	Purchase Orders
Rate Adjustments	Rate Adjustments
Rebook	Rebook
Receipts	Cash Receipts

Name	Description
Receiving	Inventory Receipts
Reclass	Reclassification
Reconciled Payments	Reconciled Disbursements
Refund Offset	Refund transactions from Student Finance
Rejection	Rejection
Release	Release
Remittance	Remittance
Renewal	Renewal
Requisitions	Requisitions
Retirement	Retirement
Revaluation	Revaluation Journal Entry
Revalue Profit/Loss	Revaluation Journal Entry for Profit/Loss Accounts
Revenue	Revenue
Reverse	Reverse
Sales Invoices	Accounts Receivable Invoices
Settlement	Settlement of Claims/Deductions
Sub-Allotment	Sub-Allotment
Sub-Allowance	Sub-Allowance
Syndication	Syndication
Tax	Tax Journal Entry

Name	Description
Total Burdened Cost	Total Burdened Cost
Trade Receipts	Trade Receipts
Transfer	Transfer
Treasury	Treasury
Treasury Confirmation	Treasury Confirmation
Usage Cost	Usage Cost
WIP	Work in Process
Write-Off	Write-Off

To define a new journal category:

1. Navigate to the Journal Categories window.
2. Enter a unique Category, Category Key, and Description for your journal category. The Category and Category Key can be the same or different. You cannot delete a category after saving your work.

The Category Key is a language-independent and instance-independent key that Journal Import uses to identify a particular journal source and category consistently across all languages and instances. If you checked the Import Using Key check box for a specific journal source, then the Journal Import program will use the Source Key and Category Key to identify the journal source and category of the imported journal.

Note: You cannot delete a category after saving your work. You can change the category name at any time. For user-defined categories, you can change the category and category key at any time.

3. (Optional) Specify the Reversal Method you want to use for this category in the Journal Reversal Criteria window. See: *Automatic Journal Reversal Overview, Oracle General Ledger User's Guide*
4. Save your work.

To review or change an existing journal category:

1. Navigate to the Journal Categories window.
2. Query the journal category you want to review or change.
3. (Optional) Make any needed changes.
4. Save your work.

Related Topics

Importing Journals, *Oracle General Ledger User's Guide*

Automatic Journal Reversal, *Oracle General Ledger User's Guide*

Suspense Accounts

If you allow suspense posting for your ledger, General Ledger uses suspense accounts to balance journals for specific sources and categories.

Defining Suspense Accounts

When you define your ledger, you enable suspense posting and assign a default suspense account to your ledger. You can define other suspense accounts in addition to the default suspense account for your ledger. General Ledger posts a balancing amount to the default account when there is no suspense account defined with a matching source and category.

Prerequisites

- Define your ledger. The ledger's data access set should be assigned to the GL: Data Access Set profile option.
- Define your journal entry sources
- Define your journal entry categories

To define a suspense account:

1. Navigate to the Suspense Accounts window.
2. Specify the Ledger. Your data access set must provide read and write access to the ledger and one or more balancing segment values or management segment values.
3. Specify the Source and Category that applies to the suspense account you are

defining.

The default suspense account you specified when you defined your ledger appears with the source and category Other. You can define additional suspense accounts using Other for either the source or the category, but not both.

Note that if you update the suspense account in the Ledger Options page in Accounting Setup Manager, the default suspense account is updated in the Suspense Accounts window. Likewise, if you update the default account in the Suspense Accounts window, the account in the Ledger Options page is updated.

4. Enter the Account against which the balancing amount should be posted. You can assign multiple unique combinations of source and category to a single account.

Note: To create the account, your data access set must provide read and write access to the ledger and the balancing segment value or management segment value used in the suspense account. You only need read-only access to view the account.

General Ledger automatically creates a suspense account for each balancing segment value. For example, if you want to create additional suspense accounts for the five companies in your chart of accounts, define suspense accounts for only one company segment value. General Ledger uses the account you enter for one company as a template for the remaining four companies. When you post out-of-balance transactions against any of the other four companies, General Ledger automatically substitutes the appropriate company segment value in your template.

5. Save your work.

Related Topics

Defining Ledgers, page 1-110

Journal Sources, page 1-156

Journal Categories, page 1-162

Transaction Codes

Important: The following section is applicable to customers who need to create additional journal lines for subledger transactions or manual journals. This feature will generate additional debit/credit pairs for any transaction line that is also tagged with a transaction code. Transaction codes are typically used by U.S. federal government customers to produce both proprietary and budgetary accounting entries for a given transaction. This feature is currently only available in public sector

installations.

Using transaction codes, you can assign additional debit and credit pairs to a single transaction and have General Ledger create the additional entries automatically. You can use transaction codes to assist in budget execution or in any situation where you would like to customize the accounting effects of one transaction. When you reference a transaction code on a data entry window, General Ledger automatically generates the additional accounting entries predefined for that transaction code.

In addition to entering transaction codes in General Ledger, you can enter transaction codes in some Purchasing, Payables and Receivables windows.

Transaction Codes and Budgetary Control

If you are using budgetary control and your Enable Transaction Code profile option is set to Yes, then General Ledger automatically generates budgetary transactions for proprietary transactions that have transaction codes and performs funds checking and funds reservation on both the proprietary and the budgetary accounts.

To use transaction codes, you must enable budgetary control. However, if you want to use transaction codes but do not want to perform budgetary control, do not set up a funding budget and turn off encumbrance accounting for your entire range of accounts.

Listing Your Transaction Codes

Use the Transaction Code Listing to view transaction codes and their associated account pairs. See: Transaction Code Listing, *Oracle General Ledger User's Guide*.

When to Use Transaction Codes

Use transaction codes whenever you need to create additional debit and credit pairs for a transaction.

Example:

You operate in compliance with the United States Standard General Ledger (USSGL), and you want to record goods or services received. You record the following proprietary entry upon receipt of goods:

DR 6100 Operating Program Expense CR 2110 Accounts Payable

And you record an additional entry to budgetary accounts to record the movement of funds as required by the USSGL:

DR 4800 Undelivered Orders CR 4900 Expended Appropriation

Example:

Your agency purchases computer equipment, and you want to set aside money to cover its replacement. You record the following proprietary entry to record receiving the computer equipment:

DR 1000 Asset For Computer Equipment CR 2110 Accounts Payable

And you record an additional proprietary entry to reserve money for future replacement:

DR 3100 Fund Balance CR 3120 Reserve For Capital Equipment

In such cases you can set up the system to generate the additional entries automatically.

Defining Transaction Codes

Use the Define Transaction Code window in General Ledger to define your transaction codes and to assign them additional accounting entries.

Example:

You define transaction code T1 with the following account pair:

DR 4800 Undelivered Orders CR 4900 Expended Appropriation

Whenever you enter Transaction Code T1 on a data entry window, General Ledger creates the additional pair of entries you specified using the Accounting Flexfield information from the original transaction.

Entering Transaction Codes

You can enter transaction codes in some windows in General Ledger, Payables, Purchasing and Receivables. The system defaults the transaction code entered to each succeeding level, such as line, shipment, and distribution. You can always override the transaction code at lower levels.

After you transfer your transactions to General Ledger, the system verifies that you have a valid enabled transaction code on each transaction. General Ledger then creates additional journal entries based on what you defined in the Define Transaction Code setup window.

Example:

Consider the following example in which a budgetary transaction is created from a proprietary transaction. The following setup is in effect:

- Accounting Flexfield structure: Appropriation--Account--Organization--Project
- The accounts listed in the table below are part of your chart of accounts.

Some accounts in your chart of accounts

ACCOUNT NAME	ACCOUNT NUMBER	ACCOUNT TYPE
Accounts Payable	2100	Liability

ACCOUNT NAME	ACCOUNT NUMBER	ACCOUNT TYPE
Undelivered Orders	4800	Budgetary
Expended Appropriation	4900	Budgetary
Operating Expense	6100	Expense

- Transaction code TC1 is defined with the pair of associated accounts as shown in the table below.

The definition of transaction code TC1.

TRANSACTION CODE	DEBIT ACCOUNT	CREDIT ACCOUNT
TC1	4800	4900

In Purchasing, you approve a purchase order and enter transaction code TC1 as shown in the table below.

The definition of transaction code TC1.

ACCOUNTING FLEXFIELD	DEBIT	CREDIT	TRANSCODE
2010804-6100-1200-700	150		TC1

The table below shows how General Ledger automatically generates the additional lines against your budgetary accounts when you check and reserve funds for the transaction, or when you post your transactions.

To create the new Accounting Flexfields, General Ledger takes the original transaction Accounting Flexfield from the shipment or distribution and substitutes the required account segment values as defined by the transaction code. General Ledger derives the dollar amounts from the original transaction.

Additional lines automatically generated by General Ledger.

ACCOUNTING FLEXFIELD	DEBIT	CREDIT
2010804-4800-1200-700	150	
2010804-4900-1200-700		150

Changing the Transaction Code on a Transaction

When you modify the transaction code at the header level of a transaction, the new transaction code defaults to any new lines or distributions you create. You cannot, therefore, change the transaction code on the lines, shipments, or distributions level by changing the transaction code at the header level.

When encumbrance accounting is on, you can modify the transaction code for an individual line, shipment or distribution only if that line, shipment or distribution has not yet been approved.

When encumbrance accounting is off, you can modify the transaction code only if the transaction has not yet been posted. If the transaction has already been approved or posted, then you must reverse or cancel the transaction.

Reversing a Transaction with a Transaction Code

When you reverse or cancel a transaction, the system copies the transaction codes from the original lines to the reversing lines.

Example:

You enter and approve a purchase order for \$150 with a transaction code of TC1 and then you later cancel the purchase order. The table below shows the original entry for the purchase order; the table that follows the table below shows the negative entry Purchasing creates when you cancel the purchase order.

Original entry for purchase order.

ACCOUNTING FLEXFIELD	DEBIT	CREDIT	TRANSCODE
2010804-6100-1200-700	150		TC1

Reversed entry created when you cancel the purchase order.

ACCOUNTING FLEXFIELD	DEBIT	CREDIT	TRANSCODE
2010804-6100-1200-700	-150		TC1

The reversed entry also has the same transaction code. Initially when you transfer your transactions from Purchasing to General Ledger, General Ledger creates the additional entries associated with the original transaction as shown in the table below. Later when you cancel the purchase order, General Ledger creates the necessary reversing entries as shown in the table following the table below.

Original additional entries created for purchase order with transaction code TC1.

ACCOUNTING FLEXFIELD	DEBIT	CREDIT
2010804-4800-1200-700	150	
2010804-4900-1200-700		150

Additional entries created to cancel purchase order with transaction code TC1.

ACCOUNTING FLEXFIELD	DEBIT	CREDIT
2010804-4800-1200-700	-150	
2010804-4900-1200-700		-150

Related Topics

Defining Preferences with User Profile Options, *Oracle Applications User's Guide*

Using Budgetary Control and Online Funds Checking, *Oracle General Ledger User's Guide*

Setting Up Transaction Codes, page 1-175

Defining Transaction Codes, page 1-176

Setting Up Transaction Codes

For transactions to generate the additional debit and credit pairs, you must install General Ledger, enable the Transaction Code profile option, and define your transaction codes. You must also enable budgetary control in your ledger.

If you want to use transaction codes but do not want to perform budgetary control, do not set up a funding budget, and turn off encumbrance accounting for your entire range of accounts.

Prerequisites

- Define your Accounting Flexfields and budgetary accounts, according to the requirements of your agency.

To set up transaction codes in your ledger:

1. Enable Budgetary Control on budgetary accounts to control expenditures against your appropriation limits. See: *Defining Ledgers*, page 1-110

Note: To use transaction codes, you must enable budgetary control, even if you do not implement budgetary control. If you do not implement budgetary control, do not set up a funding budget and turn off Encumbrance Accounting for your entire range of proprietary and budgetary accounts.

2. Enable the Enable Transaction Code profile option. See: *Setting General Ledger Profile Options*, *Oracle General Ledger Reference Guide*

Enabling this option lets you enter transaction codes in General Ledger, Oracle Purchasing, Oracle Payables, and Oracle Receivables. You can set this value at the site, application, or responsibility level.

3. Define your transaction codes by assigning them to account pairs of any type, budgetary and proprietary or both. See: *Defining Transaction Codes*, page 1-176
4. If you are subject to the Prompt Payment Act and want to associate a transaction code with interest payments, assign a transaction code to your Interest Invoices in the Define System Options and Defaults window in Payables.

When you confirm payment of interest invoices, Payables automatically creates additional transactions for your interest invoices using the transaction code you define as a system option.

Related Topics

Using Budgetary Control and Online Funds Checking, *Oracle General Ledger User's Guide*

Setting Your Personal User Profile, *Oracle Applications User's Guide*

Confirming Payment Batches, *Oracle Payables User's Guide*

Prompt Payment Support, *Oracle Payables User's Guide*

Defining Transaction Codes

Define transaction codes to assign additional debit and credit pairs to a single transaction. The system creates these additional entries automatically. When you enter actual or encumbrance journals, you can enter transaction codes at the batch, header and line level.

You cannot delete or change your transaction code once you save your work. Rather, you restrict the use of your transaction code by assigning start and end dates. Note that you can delete or modify the transaction pairs associated with a code.

You can use transaction codes across your ledgers that share the same chart of accounts.

Prerequisites

- Define your ledger using Accounting Setup Manager.
- Set the Enable Transaction Code profile option for your ledger.

To define transaction codes:

1. Navigate to the Transaction Codes window.
2. Enter the name of your transaction Code. Optionally enter the Start and End Dates that you want this transaction code to be enabled.
3. Enter the Debit and Credit Account segment values that you want automatically debited or credited when you associate this transaction code with a journal. You can enter any number of account segment value pairs for each transaction code.

When you enter a journal, General Ledger will generate additional journal lines that debit your debit accounts and credit your credit accounts for the amounts in your journal entry.

4. Save your work.

Related Topics

Setting Up Transaction Codes, page 1-175

Transaction Code Listing, *Oracle General Ledger User's Guide*

Defining Ledgers, page 1-110

Defining Preferences with User Profile Options, *Oracle Applications User's Guide*

Setting General Ledger Profile Options, *Oracle General Ledger Reference Guide*

Planning Your Summary Accounts

A summary account is an account whose balance is the sum of balances from multiple detail accounts. Use summary accounts to perform online summary inquiries, as well as speed the processing of financial reports, MassAllocations, and recurring journal formulas.

To plan your summary accounts:

1. Determine your summary account needs.
2. Plan the summary account structure to meet your needs.
3. Plan the parent segment values and rollup groups you need for your summary accounts. Make sure the pseudo parent value "T" is specified for each segment. Do not assign child accounts or ranges to this value.

Warning: The segment value "T" should only be used to mean all segment values, in other words, the total of all parent values. You cannot use it for any other purposes.

4. Plan your summary account templates to generate multiple summary accounts.

Note: You must have read and write access to the ledger and all of its balancing segment values or management segment values as defined by your data access set to create summary accounts.

You can only create summary accounts if you are using one of the following data access sets:

- The Full Ledger data access set type that provides read and write access to the ledger.
- The Balancing Segment Value data access set type that provides

read and write access to all balancing segment values for a ledger using the All Values checkbox.

- The Management Segment Value data access set type that provides read and write access to all management segment values for a ledger using the All Values checkbox.

Related Topics

Determining Your Summary Account Needs, page 1-178

Planning the Summary Account Structure, page 1-179

Planning Parent Values and Rollup Groups, page 1-183

Planning Summary Account Templates, page 1-184

Determining Your Summary Account Needs

The first step in defining your summary accounts is to determine your summary account needs. Summary accounts provide you with significant benefits when you produce summary reports and perform allocations.

To determine your summary account needs:

1. Consider the summary information you need for reports. Although you can easily define financial statements that sum a number of accounts together for a given row, you can use summary accounts for faster access to summarized balances.

For example, many of the reports for upper management in your company may include summary level amounts. You may have summary income or revenue statements and balance sheets, a summary overhead expense analysis and many other summary level reports in your management reporting package.

2. Identify the summary balances you need for online inquiries.

For example, you may need "flash" inquiries on the total of all cash balances for your domestic organizations to make daily decisions about investments or foreign currency hedging. You may also want to review the amount of working capital (current assets less current liabilities) for each division or department on a weekly basis.

3. Consider how you want to use summary accounts in formulas and allocations. You can use summary accounts as factors when defining journal formulas and allocations.
 - Use summary accounts to reference summary balances in a recurring journal

formula. For example, to estimate a sales commission accrual based on the total of all product sales for each division, you can use a summary account that totals all product sales in each division.

- Use summary accounts to reference summary budget balances in a budget formula. For example, to base the budget for employee benefits in each company on the total of all budgeted employee salaries, use summary accounts that total all employee salaries in each company.
- Use summary accounts when entering budgets with budget rules. For example, you can base your budget for the current year's Salary account on a percentage of the prior year's total Overhead expense, a summary account.
- Use summary accounts to indicate the total amount you want to allocate when defining your allocation formulas. Also, use summary accounts to help you calculate the allocation ratios to use in your allocation formulas.

Related Topics

Planning the Summary Account Structure, page 1-179

Planning Parent Values and Rollup Groups, page 1-183

Planning Summary Account Templates, page 1-184

Creating Recurring Journal Entries, *Oracle General Ledger User's Guide*

Creating Budget Formula Entries, *Oracle General Ledger User's Guide*

Defining MassBudgets, *Oracle General Ledger User's Guide*

Planning the Summary Account Structure

After determining your summary account needs, plan your summary account structure according to how you want to summarize your accounting information.

To determine your summary account structure:

1. Choose ways to summarize your accounting information depending on the structure of your account and your informational needs. Generally, organizations structure their accounts such that each segment represents a particular dimension, or a way of looking at their organization.

Here are some common dimensions and examples of ways you can summarize information within each dimension:

Company: A segment that indicates legal entities. You might summarize companies by major industry, such as Electronics Companies; by regions within a country, such as Eastern Companies; or by country group, such as European Companies.

Cost Center: A segment that indicates functional areas of your business, such as Accounting, Facilities, Shipping, and so on. You might keep track of functional areas at a detailed level, but produce summary reports that group cost centers such as Accounting, Planning & Analysis and Facilities, into one division called Administration.

Account: A segment that indicates your "natural" account, such as Cash, Accounts Payable, or Salary Expense. You will likely summarize your accounts by account type, namely your Assets, Liabilities, Equity, Revenues and Expenses. You might also summarize at a more detailed level, with summary accounts like Current Assets or Long-Term Liabilities.

Product: A segment that indicates products. You might want to summarize products into product groups such as personal computer components, storage devices, and so on.

District: A segment that indicates geographical locations, such as Northern California, Central Florida or Western New York. If you define segments that record data within smaller geographical areas, such as districts, you can easily summarize districts into states, or even into groups of states you can call regions.

2. For any organizational dimension you want to summarize, determine how many summarization levels you want within that dimension.

For example, you can summarize your natural accounts into Assets and Liabilities, or you can summarize at a more detailed level, such as Current Assets, Non-Current Assets, and so on. You can also summarize products into product groups and into larger groups called product categories. Likewise, you can summarize districts into states and then into regions.

You can also summarize at different levels within an organizational dimension. For example, you may decide to group your East Coast offices together, your West Coast offices into another group, and your Midwest offices into a third group. Each of these summary groups can then be included in separate rollup groups namely Eastern States, Western States and Midwestern States. Then, you may decide to combine these three groups into a higher level group, United States offices, and define a rollup group named Total Country Offices. If you have a single Canadian Office, you may decide to designate it as a group in itself and assign it to the rollup group Total Country Offices as well. In this example, your United States offices group is at the same summary level as your Canadian office group, but you have one summary level below the United States level, while you have no summary levels below your Canadian office.

3. To clarify your plans, sketch your summarization levels on paper. The following illustration represents the summarization of districts into states and regions:

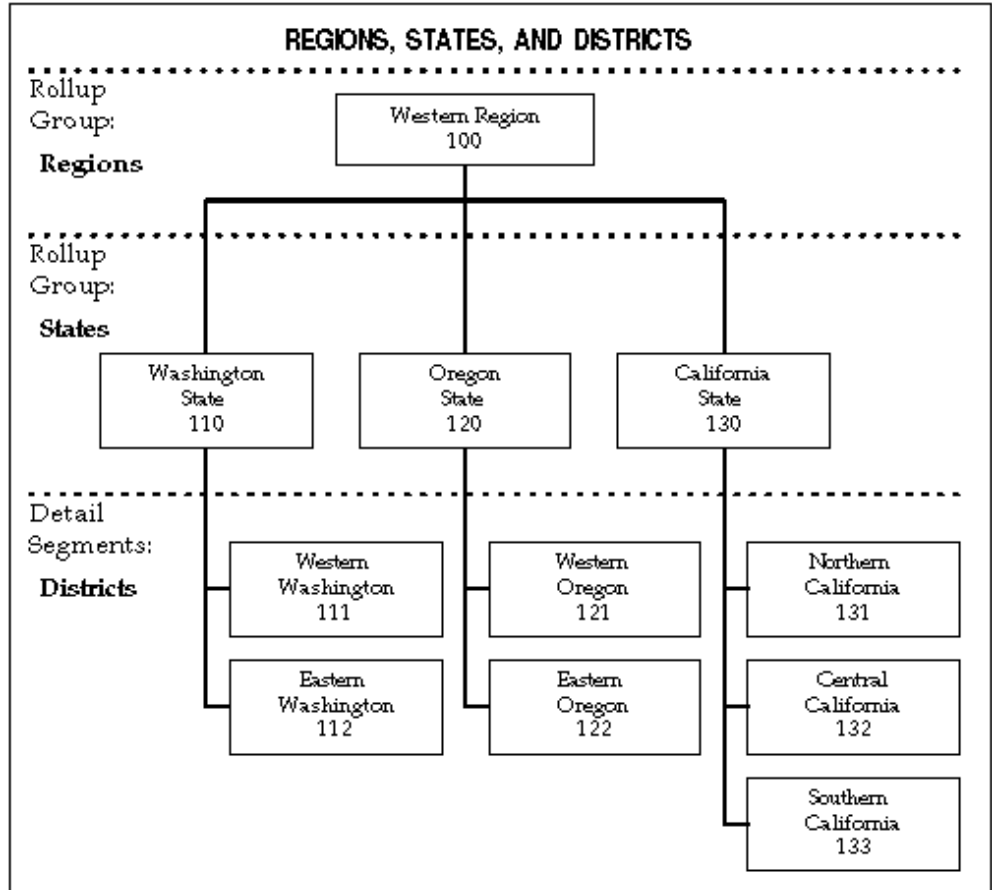

For a text description of this illustration, see *Text Description of Regions, States, and Districts, Oracle General Ledger Online Help*.

Indicate the segment value and description of each of the parents in your sketch. Also write the rollup group name or number and a description of the summary level next to each of your summarization levels. You do not need to include every parent value in a rollup group. You may define some parent values for reporting or formula definition purposes only.

For example, you may decide to group all of your cost centers under the parent value "All Cost Centers." However, if you do not plan to report on your cost centers at a summary level, there is no need to assign these parent values to a rollup group.

You can define multiple summary levels by assigning children that are parents themselves (grandparenting). For example, you can assign cost centers or departments 110, 120 and 130 as the children for cost center or department 100 - Western Region. General Ledger automatically maintains rollup relationships from the summary level to the lowest detail level so that when you transfer a child value from one parent to another, all the values assigned to the child are transferred as well. However, you can only drill down balances from the summary level to the lowest detail level, not to intermediate levels.

4. After considering how you want to summarize within each of your organizational dimensions, think about how you want to combine your summary views across different organizational dimensions. For example, if you summarize departments into divisions and districts into regions, you may wish to reference and report on divisions by region.

You can also combine a particular summary level for one organizational dimension with a different summary level for another organizational dimension. For example, you may wish to reference and report on departments by region.

To decide upon the combinations of summary views across your organizational dimensions, you can lay your summarization level sketches side by side so that you can consider your summarization levels conceptually. The following chart shows how you might roll up your account segments into several levels:

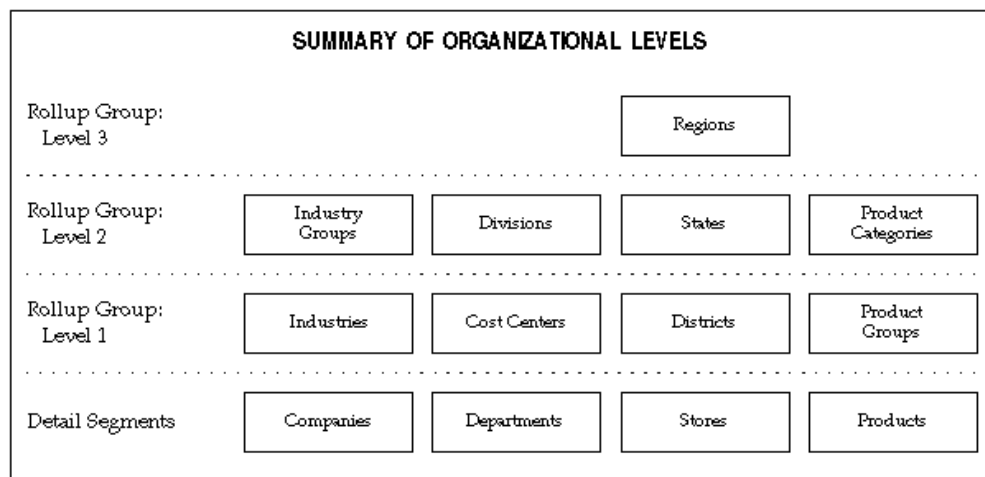

For a text description of this illustration, see *Text Description of Summary of Organizational Levels, Oracle General Ledger Online Help*

5. Consider whether you want to create these summary relationships with summary accounts, or with reporting hierarchies. You can achieve the benefits of summary reporting with reporting hierarchies instead of summary accounts. A significant benefit of using reporting hierarchies instead of summary accounts is easier reorganizations.

Use reporting hierarchies instead of summary accounts when:

- You want to easily reorganize your summary views in the future.
- Your primary use for summarization is reporting. You cannot reference reporting hierarchies in formulas, allocations or online.

Use summary accounts instead of reporting hierarchies when:

- Your summary relationships are more permanent.

- You want to use summary accounts in formulas and allocations, as well as reporting.
 - You want online inquiry of these summary amounts.
 - You want faster financial reporting of these summary amounts.
 - You want summary level budgetary control.
6. To define parents for each of your account segments, organize your account structure so you can use ranges to easily define the children for your parent values.
- For example, if you know that all of your administration cost centers are between 100 and 199, you can define the Administration parent as the range of cost center values between 100 and 199.

Related Topics

Determining Your Summary Account Needs, page 1-178

Planning Parent Values and Rollup Groups, page 1-183

Planning Summary Account Templates, page 1-184

Defining Summary Accounts, page 1-186

Entering Summary Account Templates, page 1-188

Planning Parent Values and Rollup Groups

After determining your needs and organizing your summary account structure, define your parent values and your rollup groups.

Note: You can use the Account Hierarchy Manager to create and edit your account hierarchies graphically. You can use the Account Hierarchy Manager to define parent and child segment values, as well as rollup groups.

For information on the Account Hierarchy Manager, see: The Account Hierarchy Manager, page 1-66

To determine the parent values and rollup groups you need to define:

1. Plan your parent segment values. When determining the values of parents for each account segment, consider the structure of values within that segment. If your segment values are logically organized and the child values for your parent are all in a contiguous range, a logical value for the parent is the first or last value in the range. For example, if all of your Assets are between 1000 and 1999, an appropriate

value for your Total Assets parent is 1999. If you want to use parent values like this, reserve the first or last value in your ranges for a summary value.

If your segment values do not follow a particular structure, and your segment allows alphabetic characters, you can use alphabetic characters for parent values. The alphabetic characters not only distinguish your parent values from your detail values, but they can also provide some description for the parent value.

For example, you could group your United States companies, companies 07, 12 and 18 into a parent with a value of "US."

2. Define the parent segment values, and enter meaningful segment value descriptions. For example, for rollup groups that summarize districts into states and regions you might use descriptions for your parent values such as "Washington State," and "Western Region."
3. Decide how many rollup groups you need. A rollup group maintains a summarized balance for each parent value assigned to the rollup group. You can have one rollup group for all levels of the hierarchy, or you can have one rollup group for each level of the hierarchy. Having one rollup group for all levels of the hierarchy can help reduce the number of summary templates you define, which improves performance. Having one rollup group for each level of the hierarchy enables you to only create those summary accounts that you need, but may result in more summary templates that need to be defined, which could impact performance.

Related Topics

Determining Your Summary Account Needs, page 1-178

Planning the Summary Account Structure, page 1-179

Planning Summary Account Templates, page 1-184

Entering Summary Account Templates, page 1-188

Designing Your Accounting Flexfield, page 1-34

Parent and Child Values and Rollup Groups, page 1-55

Defining Segment Values, *Oracle Applications Flexfields Guide*

Defining Rollup Groups, *Oracle Applications Flexfields Guide*

Planning Summary Account Templates

Set up templates to define and maintain summary accounts. You can enhance the speed of your summarizations by controlling the number of summary accounts created by your template. The number of summary accounts your template creates depends on the template segment values.

Use the following formula to determine the number of summary accounts any given template will create:

Number of Summary Accounts Created

=

Number of Detail Segment Values
for Each Segment with a "D" Value

X

**Number of Parent Segment Values
in the Rollup Group**
for Each Segment with a Rollup Group Name

X

1
for Each Segment with a "T" Value

For a text description of the formula, see: Text Description of the Number of Summary Accounts Created Formula, *Oracle General Ledger Online Help*

Consider the following example for a 3-segment account:

Template: D - T - States

Description	Value
Number of values in the first segment	10
Number of parent values in the rollup group for States	12
Total number of summary accounts produced	120

Related Topics

Determining Your Summary Account Needs, page 1-178

Planning the Summary Account Structure, page 1-179

Planning Parent Values and Rollup Groups, page 1-183

Defining Summary Accounts, page 1-186

Entering Summary Account Templates, page 1-188

Defining Summary Accounts

General Ledger uses summary templates to create summary accounts, whose balances are the sums of multiple detail accounts for a single ledger. Use summary accounts to perform online summary inquiries, as well as to speed the processing of financial reports, MassAllocations, and recurring journal formulas.

You specify when you want General Ledger to begin maintaining your summary account balances. You can also assign budgetary control options to a summary template for which you want to perform summary level budgetary control.

When you delete a summary template, General Ledger deletes all summary accounts created from that template and their associated balances.

Tip: To improve performance when deleting large volumes of summary templates, see *GL: Summarization Profile Options, Oracle General Ledger Reference Guide*

Data Access Sets

The data access set assigned to your responsibility determines if you can create a summary account for a ledger or query existing summary accounts.

Full Ledger Access

You must have read and write access to the ledger and all of its balancing segment values or management segment values to create and delete summary accounts.

To obtain full ledger access, your data access set must be one of the following types:

- The Full Ledger data access set type that provides read and write access to the ledger
- The Balancing Segment Value data access set type that provides read and write access to all balancing segment values for a ledger using the All Values checkbox
- The Management Segment Value data access set type that provides read and write access to all management segment values for a ledger using the All Values checkbox

Partial Access

If you have read-only access to a ledger or read and write access to some of its balancing segment values and management segment values, you will not be able to create or delete summary accounts. You will only be able to view existing summary accounts for that ledger.

Prerequisites

- Define your account segments.
- Define your rollup groups and assign the rollup groups to your parent segment values.
- Define ledgers in Accounting Setup Manager.
- If budgetary control is enabled for your ledger, define a funding budget that requires budget journals.

To define a new summary account template:

1. Navigate to the Summary Accounts window.
2. Enter a Name for the summary account template.
3. Choose the Ledger for your summary account template.

Note: Your data access set must provide read and write access to the ledger and all of its balancing segment values or management segment values to create a summary account for the ledger.

If you use reporting currencies (journal or subledger level), you can choose a reporting currency.

4. Enter the Template.
5. Enter the Earliest Period for which you want General Ledger to maintain your actual, encumbrance and budget summary account balances. General Ledger maintains summary account balances for this accounting period and for subsequent periods.
6. Enter a Description.
7. If you are using budgetary control for your ledger, set the budgetary control options for the summary template.
8. Save your work. General Ledger submits a concurrent request to add the summary accounts, and displays the Status of your summary template.

Current: The summary accounts are active.

Adding: The concurrent request to create summary accounts is pending or running.

Deleting: The concurrent request to delete summary accounts is pending or running.

Related Topics

Planning your Summary Accounts, page 1-177

Defining Summary Accounts, page 1-186

Entering Summary Account Templates, page 1-188

Maintaining Summary Accounts, page 1-189

Setting the Summary Account Budgetary Control Options, page 1-190

Defining Ledgers, page 1-110

Defining Key Flexfields, *Oracle Applications Flexfields Guide*

Defining Rollup Groups, *Oracle Applications Flexfields Guide*

Defining Segment Values, *Oracle Applications Flexfields Guide*

Entering Summary Account Templates

You enter summary account templates to create summary accounts. General Ledger uses the templates in combination with parent segment value definitions to create summary accounts.

To enter a summary account template:

From the Summary Accounts window, enter the summary account Template using one of the following values for each segment:

D: Your template creates and maintains a summary account for every detail segment value. This value creates the most summary accounts of any template value.

Note: General Ledger will not allow you to define a summary account template using only D template values.

T: Your template creates and maintains a summary account that sums balances of all detail segment values. This value creates the fewest summary accounts of any template value.

If you enter T for a segment, all summary accounts created by the template will have the value T for the segment. Therefore, the value T must be defined and enabled for the segment. Also, the segment value must be a parent and detail posting and budgeting are not allowed.

Note: Do not define a summary account template using only T template values. A template using T values for every segment will have a zero balance if your general ledger is in balance.

[Rollup Group Name]: Your template creates and maintains a summary account for each parent segment value assigned to the rollup group you specify. The more parent segment values in a given rollup group, the more summary accounts your template creates.

Related Topics

Planning your Summary Accounts, page 1-177

Planning Summary Account Templates, page 1-184

Defining Summary Accounts, page 1-186

Maintaining Summary Accounts, page 1-189

Setting the Summary Account Budgetary Control Options, page 1-190

Defining Rollup Groups, *Oracle Applications Flexfields Guide*

Maintaining Summary Accounts

If you make changes to your flexfield hierarchies that affect summary accounts, run the Incremental Add/Delete Summary Templates program to update your summary account balances with the flexfield hierarchy changes. This program lets you make changes to account hierarchies without having to drop and recreate the summary template.

The following actions cause changes in the summary account reporting structure:

- Addition of child ranges assigned to a parent value.
- Removal of child ranges assigned to a parent value.
- Assigning a new parent segment value to a rollup group.
- Removing a rollup group assignment from a parent segment value.
- Changing rollup group assignment for a parent segment value.
- Change the segment value type from a child to a parent or from a parent to a child

Changes to the account hierarchies and rollup group assignments are ignored until the Incremental Add/Delete Summary Templates Program is run.

Choose the Incremental Add/Delete Summary Templates from the Submit Request window.

Note: You also need to run the program, Maintain Summary Templates to update summary accounts for flexfield hierarchy- related changes that will not update balances.

Incremental Add/Delete Summary Template Program Performance

The amount of time it takes the Incremental Add/Delete Summary Template Program to complete depends on several factors, such as:

- Degree of complexity of the summary account template.
- Number of parents assigned to each affected rollup group.
- Number of detail child values that are assigned to the affected parent values.
- Number of periods for which summary account balances have to be maintained.
- Maintenance of average daily balances for summary accounts.
- Extent of changes made to the account hierarchies.

Maintain Summary Templates Program

Use this program to ensure that summary account balances reflect new detail accounts that may have been added to that summary account. The posting process automatically maintains summary accounts but running this program is beneficial if many new detail account combinations have been created since the last posting. Run this program when you make changes to detail accounts to improve the performance of the posting program.

Related Topics

Planning your Summary Accounts, page 1-177

Defining Summary Accounts, page 1-186

Entering Summary Account Templates, page 1-188

Setting the Summary Account Budgetary Control Options, page 1-190

Setting the Summary Account Budgetary Control Options

You can set various budgetary control options for a summary account template, such as the funds check level and the funding budget.

To set the budgetary control options for a summary account template:

1. Navigate to the Summary Accounts window.

2. Enter the summary account template Name.
3. Choose the Ledger.

Note: Your data access set must provide read and write access to the ledger and all of its balancing segment values or management segment values to create a summary account for the ledger.

4. Enter the summary account Template.
5. Enter the Earliest Period for which you want General Ledger to maintain your actual, encumbrance and budget summary account balances. General Ledger maintains summary account balances for this accounting period and for subsequent periods.
6. Select the Budget Control button and enter the Funds Check Level, *Oracle General Ledger User's Guide*.

If you choose the Advisory or Absolute funds check level, you must enter values in the remaining budgetary control fields. You cannot enter values in these fields if you choose the None funds check level.

7. Assign a Debit or Credit balance type to your summary template. General Ledger uses the balance type to determine if funds are available, based on the funds available equation:

Funds Available = Budget - Actual - Encumbrance

- For summary accounts with a Debit balance, General Ledger considers funds available to be sufficient if the funds available equation yields a positive result.
- For summary accounts with a Credit balance, General Ledger considers funds available to be sufficient if the funds available equation yields a negative result.

Assigning a balance type of debit or credit to a summary account does not restrict the balance type of the detail accounts that roll up into a summary account.

8. Enter the Amount Type, or cumulative balance used in the funds checking interval. See: Amount Type and Boundary, *Oracle General Ledger User's Guide*
9. Enter the Boundary, or the endpoint of the funds checking interval. Combined with the amount type you specify, boundary determines the time interval over which to perform summary level budgetary control. See: Amount Type and Boundary, *Oracle General Ledger User's Guide*
10. Enter the Funding Budget against which you want General Ledger to check or reserve funds.

You can only choose a funding budget that requires journal entries. General Ledger requires you to create budget journal entries for your funding budget to enforce budgetary control.

To change the funds check level:

You are not allowed to add new rows after the summary template is saved, because then the associated rows is missing from the GL_BC_PACKETS table. You are not allowed to delete rows after the summary template is saved, because extra rows would exist in GL_BC_PACKETS table.

If you want to change the funds check level from *None* to *Advisory* or *Absolute*, you must delete the summary template and then recreate it with the appropriate funds check level. General Ledger does not perform summary level budgetary control retroactively for the summary accounts it creates.

Related Topics

Planning your Summary Accounts, page 1-177

Defining Summary Accounts, page 1-186

Entering Summary Account Templates, page 1-188

Maintaining Summary Accounts, page 1-189

Defining Budgets, *Oracle General Ledger User's Guide*

Using Online Budgetary Control and Online Funds Checking, *Oracle General Ledger User's Guide*

Defining Statistical Accounts

General Ledger lets you maintain statistical as well as monetary balances for any account. However, in some cases you may want to set up separate accounts specifically for statistical information. For example, you might want to enter the units sold statistic in your Sales Revenue and Sales Expense accounts, but enter the square feet statistic in only a single account, say the SQFT account.

To define a statistical account:

Set up your statistical accounts the same way you set up all other accounts. When you define your statistical accounts, you can also define cross-validation rules. This ensures that the combination of segments you enter is always valid. For example, you might decide that statistical accounts 9000-9025 should only be used with company 01 because these statistical accounts hold the headcount totals for each division in company 01 only.

Reporting on Statistics

If you maintain statistical information in General Ledger, you can produce standard and custom reports to track statistical balances. You can also run online inquiries to see statistical data.

Standard Reports: Request one of the General Ledger standard reports, specifying STAT as your currency. You can produce the report for specific accounts and accounting periods.

Custom Reports: Use the Financial Statement Generator to combine statistical and monetary information in a single report, or create separate statistical reports.

- To produce a statistical report, use a row set that contains only statistical rows.
- To combine statistical and financial information in a single report, use a column set that contains both monetary and statistical type columns. This type of column set will be useful when you want to produce a consolidating report for your multi-company organization that includes revenue, expense and resource information.

Inquiries: Perform journal and account inquiries to review information about your statistical journal transactions and statistical account balances. When you run an inquiry, enter STAT as the currency to see only statistical data.

Related Topics

Defining Accounts, page 1-59

Defining Cross-Validation Rules, *Oracle Applications Flexfields Guide*

Defining Row Sets, *Oracle General Ledger User's Guide*

Running Financial Reports, *Oracle General Ledger User's Guide*

Defining Financial Report Sets, *Oracle General Ledger User's Guide*

Performing a Journal Entry Inquiry, *Oracle General Ledger User's Guide*

Performing an Account Inquiry, *Oracle General Ledger User's Guide*

Running Reports and Programs, *Oracle Applications User's Guide*

Defining Statistical Units of Measure

Define statistical units of measure if you want to enter both statistical and monetary amounts for the same account within a single journal entry. You can maintain any type of statistical account, including headcount, number of units produced or sold, and so on. You associate a single unit of measure with an account segment value. You must also enable the profile option Journals:Mix Statistical and Monetary.

Note: To enter both statistical and monetary amounts for budget journals, you must assign accounts to your budget organization using both monetary and STAT currencies. Also, you cannot enter statistical amounts for budget journals if you are using budgetary control.

Use the Units of Measure Report to review your statistical units of measure and the account segment values to which you assigned them.

Prerequisite

- Define your column in Accounting Setup Manager.
- A data access set that includes the ledger must be assigned to the GL: Data Access Set profile option.

To define a statistical unit of measure:

1. Navigate to the Statistical Units of Measure window.
2. Enter the Account segment value that you want to associate with a statistical unit of measure. You can only enter detail account segment values (no parent account segment values), and you can enter only one unit of measure for each account segment value.

You can change the unit of measure associated with an account segment value at any time.

3. Enter a Unit of Measure name and Description. For example, you might enter a unit of measure "Hours" with a description "Hours Worked."
4. Save your work.

Related Topics

Defining Ledgers, page 1-110

Entering Statistical Journals, *Oracle General Ledger User's Guide*

Unit of Measure Report, *Oracle General Ledger User's Guide*

Document Sequences

Document Sequences are used in General Ledger, but discussed in the *Oracle E-Business Suite Setup Guide*. For convenience, we have reproduced the related section of that guide here.

For more information, please see the *Oracle E-Business Suite Setup Guide*.

Defining Document Sequences

Create a document sequence to uniquely number each document generated by an Oracle application. In General Ledger, you can use document sequences to number journal entries, enabling you to account for every journal entry.

Important: Once you define a document sequence, you can change the Effective To date and message notification as long as the document sequence is not assigned. You cannot change a document sequence that is assigned.

To create a new document sequence:

1. Navigate to the Document Sequences window.
2. Enter a unique Name for your document sequence.
3. Select Oracle General Ledger as the Application to associate with the document sequence. Audit records for your sequence are stored in the application's audit table.
4. Enter the Effective From and To dates for your document sequence.

If there is no end date defined and there are no assignments for a sequence, you can disable the sequence by entering the current date as the end date. Once disabled, you cannot reactivate a sequence.

5. Select the Type of numbering you want your documents to have from the following options:
 - **Automatic:** General Ledger sequentially assigns a unique number to each document as it is created. Documents are numbered in order by date and time of creation. Numbers are in sequential order by date and time of creation.
 - **Gapless:** General Ledger sequentially assigns a unique number for each document, but ensures that the document was successfully generated before assigning the number. With Gapless numbering, no sequence numbers are lost due to incomplete or failed document creation.

Tip: We recommend that you choose this type only when gapless numbering is essential, as it may affect the performance of your system.

- **Manual:** The user must assign a number to each document when it is created.

You must enter unique values. Sequential ordering and completeness are not enforced.

6. For an automatic sequence, choose whether to display a Message to inform the user of the sequence name and number.
7. For an automatic sequence, enter an Initial Value for the first document in your sequence.
8. Save your work.

General Ledger launches a concurrent process to create the document sequence.

9. When the concurrent process is completed, assign the sequence to an application and category, and optionally to a ledger and method.

Assigning Document Sequences

After defining document sequences, you must assign a specific sequence to an application and category. If you enabled the Ledger and/or Method Document Flexfield segments, you can also assign sequences based on the ledger and/or creation method of the document.

You can assign sequence numbers to journal entries, but only to those journals created for actual transactions. You can choose to assign sequence numbers to journal entries that General Ledger automatically creates, or to journal entries you enter manually in the Enter Journals window. General Ledger automatically creates journal entries for actual transactions when you perform the following tasks:

- Import Journals
- Reverse Journals
- Revalue Balances
- Generate Recurring Journals
- Generate MassAllocation Journals
- Consolidate Ledgers
- Eliminations

You can assign only one active document sequence scheme to each unique combination of Application, Category, Ledger, and Method. However, you can assign the same document sequence to more than one combination of Application, Category, Ledger, and Method.

Note: You should not assign a manual sequence to an Automatic method.

Prerequisite

- Define your document sequences.

To assign document sequences:

1. Navigate to the Sequence Assignments window.
2. Enter the Application that generates the documents you want to number. For General Ledger, enter Oracle General Ledger.
3. Select the Category of the journals you want to number.
4. Enter a Start Date for the sequence assignment. Once you define a sequence assignment, you cannot change the Start Date.
5. Enter an optional End Date. If you enter an end date and define your sequence assignment, the end date cannot be modified later. If you leave this field blank, your sequence assignment does not expire.

Note: If you enter start and end dates, you can only use your sequence assignment to assign document numbers to journal entries for which the journal effective date falls between the start and end dates.

If there is no end date defined and there are no active assignments for a sequence, you can disable the sequence assignment by entering the current date as the end date. Once disabled, you cannot reactivate a sequence assignment.

6. Enter a Sequence name. You can only choose document sequences that you defined for the application you specified.

Related Topics

Planning Your Descriptive Flexfields, *Oracle Applications Flexfields Guide*

Assigning Document Sequences by Ledger and Entry Method, page 1-198

Defining Descriptive Flexfield Segments, *Oracle Applications Flexfields Guide*

Defining Document Sequences, *Oracle Applications User's Guide*

Assigning Document Sequences by Ledger and Entry Method

You can also assign document sequences based on the ledger and/or the creation method of the document. To assign sequences by ledgers and/or entry method, you must enable the Ledger and/or Method Document Flexfield segments.

Prerequisite

- Define your document sequences.
- Enable the Ledger and/or Method Document Flexfield segments.

To assign document sequences:

1. Navigate to the Sequence Assignments window.
2. Select the Application that generates the documents you want to number.
3. Select the Category of the documents you want to number.
4. If you are assigning document sequences by the ledger, enter the Ledger to which the document numbering applies.
5. If you are assigning document sequences by entry method, select the creation Method of the documents:

Automatic: Assign sequential numbers to journal entries created automatically by General Ledger. Do not assign sequences defined with a manual numbering type to an automatic creation method.

Manual: Assign sequential numbers to journal entries you enter manually using the Enter Journals window.
6. Enter a Start Date for the sequence assignment. Once you define a sequence assignment, you cannot change the Start Date.
7. Enter an optional End Date.
8. Enter a Sequence name. You can only choose document sequences that you defined for the application you specified.

Note: You should not assign sequences defined with a manual entry method to an automatic creation method.

You can assign only one active document sequence scheme to each unique combination of Application, Ledger, Category, and Method. However, you can assign the same document sequence to more than one combination of Application, Ledger, Category, and Method.

Related Topics

Assigning Document Sequences, page 1-196

Defining Descriptive Flexfield Segments, *Oracle Applications Flexfields Guide*

Defining Document Sequences, *Oracle Applications User's Guide*

Upgrading Balances to Track Balances Entered in the Ledger Currency

You can optionally choose to track entered currency balances that have been entered using the ledger currency separately from balances that have been converted to the ledger currency.

If you are upgrading Oracle General Ledger from Release 11.5.10, you can optionally choose to track entered ledger currency balances separately from converted ledger currency balances. This enables you to view account balances that were entered using your ledger currency separately from those foreign currency entered amounts that were converted to your ledger currency.

For example, assume your ledger currency is USD; the currency that has been assigned to your ledger. Assume you enter the journals below. The first journal is entered using the ledger currency and the last two journals are entered using foreign currencies, CAD and EUR, respectively.

USD Entered Amounts

Account	Debit	Credit
01.110.6110	1000.00	
01.000.2110		1000.00

Account	CAD Entered Amounts		USD Converted Amounts	
	Debit	Credit	Debit	Credit
01.110.6110	1500.00		1233.00	
01.000.2110		1500.00		1233.00

Account	EUR Entered Amounts		USD Converted Amounts	
	Debit	Credit	Debit	Credit
01.110.6110	1000.00		1294.00	
01.000.2110		1000.00		1294.00

If you choose to track your entered ledger currency balances separately from the balances that have been converted to your ledger currency, the following balances would be maintained for the following accounts.

Entered Ledger Currency Balances:

Choosing to view account balances that were entered using your ledger currency would retrieve the following balances.

Account	USD Entered Ledger Currency Balances	
	Debit	Credit
01.110.6110	1000.00	
01.000.2110		1000.00

Any foreign currency amounts that were converted to the ledger currency are ignored in this query.

Note: If you do not choose to track your entered and converted ledger currency balances separately, then you would not be able to obtain this view of your account balances.

Converted Ledger Currency Balances:

Choosing to view all balances by your ledger currency would retrieve the following balances:

USD Converted Ledger Currency Balances		
Account	Debit	Credit
01.110.6110	3527.00	
01.000.2110		3527.00

These amounts include all amounts that were entered using the ledger currency as well as foreign currency amounts that were converted to your ledger currency.

Generate Upgrade for Balances Entered in Ledger Currency Program

To upgrade your balances to track balances entered in your ledger currency separately from balances converted to your ledger currency, you must run the Generate Upgrade for Balances Entered in Ledger Currency program. This program automatically launches the following child requests:

1. **Upgrade Balances Entered in Ledger Currency:** This program upgrades all balances to enable you to track entered ledger currency balances separately from converted ledger currency balances.
2. **Upgrade Balances Moved by Mass Maintenance:** This program upgrades all balances in the interim move/merge tables that were created using Mass Maintenance. This program ensures that all interim tables are properly upgraded in the event that you reverse the move/merge after upgrade.

Parameters

When you run the Generate Upgrade for Balances Entered in Ledger Currency program, you must specify the following parameters:

- **Number of Accounts to Process Per Batch:** Determines the number of account combinations to process at a time.
The default value is 1000. This means that each worker will process 1000 account combinations at a time when upgrading balances.
- **Number of Upgrade Workers:** Allows multiple upgrade processes to run in parallel to speed processing when you have large volumes of balances to upgrade. If one upgrade process fails due to an error, the other processes will continue.
Specify a number equal to the number of processes you want to run at the same time. The default value is 2, and one worker is always required for the Upgrade Balances Moved by Mass Maintenance program. You can change the default to a

higher number to have additional workers submitted for the Upgrade Balances Entered in Ledger Currency program.

For example, if you enter 10 for the Number of Upgrade Workers, then nine programs will be submitted for the Upgrade Balances Entered in Ledger Currency program and one program will be reserved for the Upgrade Balances Moved by Mass Maintenance program.

Note: You can run the Generate Upgrade for Balances Entered in Ledger Currency program at any time after you upgrade from Release 11i.

Note: If you do not run this program, you will not be able to take advantage of the Entered Ledger Currency Balances feature. When you view account balances, you will not be able to view those balances that were entered using the ledger currency.

Conflicts with Other Processes and Activities

You should only run the Generate Upgrade for Balances Entered in Ledger Currency program when no conflicting activity is taking place. The following categories of activities conflict with this program:

- **Balance Processing:** includes posting, archiving and purging, and opening periods.
- **Mass Maintenance:** includes moving and merging balances.

All concurrent processes and online activity that fall into the above categories should be completed before you submit the program.

Tip: Consider excluding the program from the standard concurrent manager. Instead, assign the program to a special concurrent manager queue that becomes active only at specified times.

To upgrade balances to track balances entered in your ledger currency:

1. Navigate to the Submit Requests window.
2. Select the concurrent program named Program – Generate Upgrade for Balances Entered in Ledger Currency.
3. In the Parameters window, choose the Number of Accounts to Process Per Batch and the Number of Upgrade Workers.

4. Submit the request.
5. This request automatically launches two programs: Upgrade Balances Entered in Ledger Currency and Upgrade Balances Moved by Mass Maintenance.

After all programs have completed, your balances are upgraded. You will be able to query and report on balances that have been entered in your ledger currency separately from those balances that have been converted to your ledger currency.

If you are using reporting currencies (journal or subledger level), running these programs also tracks entered currency balances that have been entered using the reporting currency separately from balances that have been converted to the reporting currency.

Entering Employees

Some GL features, such as Journal Approval, require setting up employees or contract (contingent) workers in Oracle Human Resources Management System. This setup can be performed whether or not Oracle HRMS is installed in your environment. For convenience, the related section of the Oracle HRMS documentation is included here.

If you want to read the entire HRMS chapter, please see the *Oracle Human Resources Management User's Guide*.

Setting Up Automatic Tax Calculation

Use the Tax Options window to set up automatic tax calculation on taxable journal entry lines. You can set up tax details at the ledger level to default to all taxable journal lines entered in the ledger, or at the natural account level to default to taxable journal entry lines for specific accounting segments. E-Business Tax calculates the tax according to the tax configuration and the tax rules defined for the configuration owner, tax regime and tax.

Set up tax calculation default information for each combination of ledger and configuration owner that requires taxable journal entries. E-Business Tax uses the tax determination processes of the configuration owner to calculate taxes in each ledger. If journal entries for a specific account are usually or always taxed at a certain rate or with a certain tax rate code, you can set up tax calculation default information for this account only.

The tax information that you define at the ledger level defaults to the journal entry line Tax Information descriptive flexfield. If defined, the ledger level tax rate code or natural account segment tax rate code defaults to the journal entry line Tax Rate Code field.

Because the E-Business Tax tax rate code applies to either Procure to Pay or Order to Cash transactions, the tax class for tax records created in Release 12 is *Input/Output*. If you are using Release 11*i* migrated tax data on journal entry lines, then the Ledger region displays two records for *Input* tax class and *Output* tax class. You can set up a

record for the complementary tax class, as necessary.

If you assign a tax rate code to a natural account segment, you can use the Enforce Tax from Account configuration option to use this tax rate code to calculate tax on transactions associated with the natural account segment of the account entered in the distribution. You set this option for each applicable configuration owner and event class.

You can also use the Tax Options window to set up natural account segment default information for tax classification codes that use the Release 11i defaulting hierarchy model. See: Setting Up Tax Classification Code Defaults, page 1-209 for more information.

Prerequisites

- Update your standard operating procedures for entering journals for taxable transactions.
- Enable the journal entry tax option for each applicable ledger. See: Creating Accounting Setups, *Oracle Financials Implementation Guide* for more information.
- Set up the basic tax configuration and tax rules for each applicable configuration owner. See: Evaluating Your Tax Configuration, *Oracle E-Business Tax User Guide* for more information.
- Set up configuration options for the applicable configuration owners and event classes with the Enforce Tax from Account option enabled. See: Setting Up Configuration Owner Tax Options, *Oracle E-Business Tax User Guide* for more information.

To set up automatic tax calculation during journal entry:

1. Enter the ledger and configuration owner.
The Tax Reporting Currency field displays the ledger functional currency and the Precision field displays the default precision for the ledger functional currency.
2. Enter or update the parameters to use to calculate tax amounts in the ledger functional currency. If defined, these values override the values defined at the tax regime or tax level, if different:
 - In the Precision field, enter a one-digit number to indicate the number of decimal places to calculate tax.
 - In the Minimum Accountable Unit field, enter the smallest unit a tax amount can have. For example, enter .01 for the US dollar.
 - If applicable, check the Allow Rounding Rule Override box to let users override the rounding rule defined at the ledger level or account level in the taxable

journal Tax Information descriptive flexfield.

3. Select the calculation level:
 - *Journal* - E-Business Tax groups together tax lines with the same tax regime, tax, tax status code and tax rate code into one tax line.
 - *Line* - E-Business Tax creates separate tax lines and does not perform any grouping operation.
4. Define ledger level defaulting values in the Ledger tabbed region. These values default to all accounts in the ledger:
 - Select the tax class.

For Release 12 records, the read-only tax class is Input/Output. For migrated records, if there is a default defined for either Input or Output only, then create a record for the other tax class. E-Business Tax still derives the tax rate from the tax rate code.
 - Enter the tax regime code.

You can enter any tax regime belonging to the configuration owner.
 - Enter the tax, tax status code, and tax rate code.
 - Select the rounding rule to use for this ledger.

The rounding rule is the method to use to round off taxes to the minimum accountable unit.
 - Check the Amount Includes Tax box to calculate tax amounts for this ledger using a tax inclusive formula.
5. Navigate to the Account Tax Rates tabbed region to define defaulting values for a natural account segment.

Note: You cannot specify account-level defaults for different cost centers or other Accounting Flexfield segments.
6. Enter an account belonging to the ledger.

The values you define here override the values defined at the ledger level for this account.
7. Select a tax class:
 - *Input/Output* - Tax class for Release 12 records.

- *Input or Output* - For migrated records, create either an Input or Output record, as necessary. E-Business Tax still derives the tax rate from the tax rate code.
 - *Non Taxable* - Tax is not calculated on journal line entries for this account segment. The regime-to-rate fields are disabled.
8. Enter the tax regime, tax, tax status, and tax rate code to use for this account segment.
 9. Check the Allow Tax Rate Code Override box to let users override the tax rate code defaulted to the taxable journal Tax Rate Code field.
 10. Check the Amount Includes Tax box to calculate tax amounts for this account segment using a tax inclusive formula.

Tax Calculation Rules

This section describes the rules used to calculate taxes on taxable journal entry lines.

Formulas and Rounding

For tax-exclusive entered amounts, the system creates additional journal lines with the appropriate calculated tax amount, and leaves the entered line untouched:

$$\text{Calculated tax amount} = \text{entered amount} \times \text{tax rate}$$

$$\text{Net amount} = \text{entered amount}$$

For tax-inclusive amounts, the system calculates the amount of tax inherent in the entered amount and creates a corresponding tax line, and it also replaces the entered amount with a smaller *net* amount:

$$\text{Calculated tax amount} = \text{entered amount} \times (\text{tax rate} / (100 + \text{tax rate}))$$

$$\text{Net amount} = \text{entered amount} - \text{calculated tax amount}$$

Each calculated tax amount is denoted in the current ledger functional currency, and uses a tax precision and minimum accountable unit specified by the tax options for the current ledger. (The tax precision can be different from the overall precision for a currency.)

Tax amounts are rounded Up, Down, or Nearest to meet the tax precision and minimum accounting unit, according to the rounding rule entered, defaulted, or enforced for the ledger.

Rounding Example

Suppose you are calculating taxes in a particular legislation and that the minimum accountable unit is .01. Even though the minimum accountable unit for that legislation currency is .01, tax amounts are always rounded to the nearest .05 currency units. You would define this by specifying a tax precision of 2 and a tax minimum accountable unit of .05 for your ledger. Then, a calculated tax amount of 1.45 will be rounded up to 1.50.

Generated Tax Line

The system creates a journal line for each calculated tax amount; the journal line debits or credits the account associated with the corresponding tax rate code of the entered amount.

The system derives a Description for each calculated tax line as follows:

(tax rate code) tax at (tax rate)% for line (line number): (line description)

Line-level Tax Calculation

For line-level calculation, each journal line is considered one at a time. If an amount is tax-exclusive, the system creates a separate, corresponding tax line, debiting or crediting the appropriate tax liability by the calculated tax amount. For tax-inclusive amounts, the system creates a separate tax line, and it also *reduces* the entered amount (existing line) by the calculated tax amount.

Example: Line Level Calculation

Suppose you need to enter information for an employee business trip expense. You received the employee expense report, which contains the information shown in the following table:

Line	Description	Amount	Tax	Gross Amount
1	Hotel fee	40	1	41
2	Travel expense	57 (tax included)	-	57
	Total			98

In this transaction, the hotel expense amount in line 1 excludes tax, while the travel expense in line 2 includes tax.

Let us also assume that the following tax parameters apply to this transaction:

Parameter	Value
Tax rate code:	Consumption (3% tax rate)
Rounding rule:	Down
Tax account:	01-000-2200
Tax currency precision:	0

Using the Journal Entry window, you enter the first line as an expense of 40 (ignoring the tax), and the second line as an expense of 57, as shown in the table below:

Line	Account	Debit	Credit	Desc	Tax Rate Code	Includes Tax?	Rounding Rule
1	01.000.51 00	40		Hotel Fee	Consump	No	Down
2	01.000.52 00	57		Travel Expense	Consump	Yes	Down

Note that the resulting journal will temporarily be out of balance.

At this point, you can calculate tax on the journal line (by saving, then choosing Tax Journal).

Calculating tax for line 1, we get a tax amount of 1.2, which we then round down to 1. The entered amount is left untouched, since it is tax exclusive.

For line 2, we get a tax amount of 1.66, which is then rounded down to 1, and a net amount of 56 (57 minus 1).

After you calculate tax, the journal looks like the information in the following table:

Line	Account	Debit	Credit	Desc	Tax Rate Code	Includes Tax?	Rounding Rule
1	01.000.51 00	40		Hotel Fee	Consump	No	Down
2	01.000.52 00	56		Travel Expense	Consump	Yes	Down
3	01.000.55 00	1		Consump Tax at 3% of line 1: Hotel fee	Consump		
4	01.000.55 00	1		Consump tax at 3% of line 2: Travel expense	Consump		

Note that the tax calculation process automatically reduced the travel expense amount from 57 to 56, since this amount included tax.

You can then enter an offsetting total liability line in your journal to balance, as shown in the table below.

Line	Account	Debit	Credit	Desc	Tax Rate Code	Includes Tax?	Rounding Rule
5	01.000.21 00		98	Liability			

Journal-level Tax Calculation

Journal-level tax calculation differs from line-level calculation in several ways:

- The system generates one tax amount line for all tax amounts calculated by the same tax regime, tax, tax status, and tax rate, rather than generating one tax amount line for each entered amount line.
- Tax-inclusive entered amounts are reduced by the calculated tax amount, similar to line-level calculation.

General Ledger applies any rounding correction to the calculated tax amount of the largest taxable line in a group.

Setting Up Tax Classification Code Defaults

If a Payables or Receivables tax code was assigned to an operating unit account in Release 11i, the tax code migrates to E-Business Tax as a tax classification code. Use the Tax Classification Code Defaults tabbed region to update or assign a tax classification code to an operating unit account, if you use the Natural Account or Revenue Account option in the Application Tax Options defaulting hierarchy to retrieve a valid tax classification code.

E-Business Tax defaults a Natural Account tax classification code to a Payables invoice or a Revenue Account tax classification code to a Receivables invoice. If defined, you can update the tax classification code on the transaction line. E-Business Tax uses the tax classification code to evaluate direct tax rate determination rules for tax determination and tax calculation.

Note: The Tax Classification Code Defaults tabbed region is only used for selecting tax classification codes for direct tax rate determination. It is not related to the setup of ledgers and ledger accounts for automatic tax calculation of taxable journal entries.

To update or assign a tax classification code to an account:

1. Enter the operating unit and operating unit account.

You can select any operating unit within your security profile.

2. Select an *Input* tax class if this is a Payables account, or an *Output* tax class if this is a Receivables account.
3. Enter or update the tax classification code.
4. Check the Allow Tax Classification Code Override box to let users override the defaulted tax classification code on the invoice line.

Related Topics

Using Application Tax Options, *Oracle E-Business Tax User Guide*

Using Direct Tax Rate Determination, *Oracle E-Business Tax User Guide*

Using Tax Classification Codes, *Oracle E-Business Tax User Guide*

Setting Up Journal Reconciliation

This section describes the steps for setting up General Ledger Entry Reconciliation. Use this checklist to help you complete the appropriate steps in the correct order.

1. Enable reconciliation for account segment values, page 1-210
2. Enable reconciliation for code combinations, page 1-211
3. Select the Enable Journal Reconciliation checkbox for the ledger in the Ledger Options page in Accounting Setup Manager.

For information on ledger setup, see Completing Ledger Options.

1. Enable Reconciliation for Account Segment Values

Enable reconciliation for the natural accounts that should balance to zero. You can enable or disable reconciliation for an account segment value in the Segment Qualifiers window.

After you enable or disable reconciliation for an account segment value, all new code combinations created with that account segment value inherit that reconciliation setting. If you want existing code combinations to inherit the reconciliation settings, you can run the Inherit Segment Attributes program. You can also override the default reconciliation setting for a specific code combination by enabling or disabling reconciliation at code combination level. For more information, see Step 2. Enable Reconciliation for Code Combinations, page 1-211.

To enable or disable reconciliation for account segment values:

1. Navigate to the Segment Values window. The Find Key Flexfield Segment window

appears on top of the Segment Values window.

2. In the Find Key Flexfield Segment window, query your Accounting Flexfield structure by entering the structure name in the Structure field and the account segment name in the Account field, and pressing the Find button.
3. Navigate to the Values region.
4. In the Values region, navigate to the Values, Hierarchy, Qualifiers tabbed region.
5. Navigate to the Qualifiers field for the account segment value that you want. The Segment Qualifiers window appears.
6. Select *Yes* from the list of values in the Reconciliation Flag field to enable reconciliation for this account segment value. Select *No* to disable reconciliation for this account segment value.
7. Press the OK button.
8. Repeat steps 5 through 7 for each account segment value that you want.
9. Save your work.

2. Enable Reconciliation for Code Combinations

You can enable or disable reconciliation for specific accounting code combinations using the Reconciliation Combinations flexfield in the GL Accounts window. In this way, you can override the default reconciliation setting inherited from the account segment value.

Note: To keep existing account code combinations with the reconciliation flag already enabled active as reconciliation accounts, its natural account segment value also has to have the reconciliation flag enabled.

To enable or disable reconciliation for accounting code combinations:

1. Navigate to Setup > Accounts > Combinations.
2. Query your account combination.
3. Scroll to the right.
4. Select or deselect the Reconcile checkbox to enable or disable reconciliation respectively.
5. Save.

Defining Financial Schedules

You can create General Ledger financial schedules based on different calendars and period types. You can then schedule standard reports, Financial Statement Generator (FSG) reports, AutoAllocation sets, Recurring Journals, MassAllocations, Budget Formulas, and MassBudgets to run according to the General Ledger schedules you have defined. Your journals are automatically generated based on the schedule you assigned. All schedules can be shared across ledgers regardless of the calendar or period type used in the schedule. You can define multiple schedules for each calendar and period type in General Ledger.

To define a financial schedule:

1. Navigate to the Concurrent Request Schedules window.
 2. Enter a schedule name.
 3. Choose a pre-defined calendar:
 4. Choose a period type.
 5. Enter a Run Day:

Enter a number from 1 to 366. For example, selecting 5 for run day sets your request to run on the 5th day of the period.

If you want to run the schedule on the last day of every period, enter a number greater than the maximum number of days in any period, such as 32 for a monthly period containing 31 days. Any number that exceeds the maximum number of days for any period automatically sets the system to run the schedule on the last day of that period.
 6. Enter the time in 24 hour format HH:MM:SS. This is the time you want your program to run on the day specified above.
 7. Check the enabled check box to allow scheduling to be applied from the Standard Report Submission Form.
 8. Save your work.
- Note:** In order to use this feature, The Scheduler/PreReleaser concurrent manager must be running. This is a separate concurrent manager used for advanced scheduling purposes.

Related Topics

Defining Calendars, page 1-103

Automatic Journal Scheduling, *Oracle General Ledger User's Guide*

Storage Parameters for Interim Tables

You can change the storage parameters for all interim tables and indexes in General Ledger. Several concurrent programs in General Ledger use interim tables as temporary storage space for transaction data. These programs create interim tables when they start and drop them when they finish.

Although the default storage parameters meet the needs of most installations, you can increase interim table allocations if the default parameters are inadequate.

The following General Ledger concurrent programs use interim tables:

Average Balance Translation: GL_DAILY_XRATE_INT, GL_DAILY_XLATE_INT

Consolidation: GL_CONS_INTERIM, GL_CONS_INTERFACE

MassAllocations: GL_ALLOC_INTERIM

Move/Merge: GL_MOVEMERGE_INTERIM, GL_MOVEMERGE_BAL,
GL_MOVEMERGE_DAILY_BAL

Archive and Purge: GL_ARCHIVE_BALANCES, GL_ARCHIVE_BATCHES,
GL_ARCHIVE_DAILY_BALANCES, GL_ARCHIVE_HEADERS,
GL_ARCHIVE_LINES, GL_ARCHIVE_REFERENCES,
GL_ARCHIVE_SEGMENT_VALS

Segment Value Inheritance: GL_SEGVAL_INHERIT_INT

Prerequisite

- Determine the amount of storage space that you want to allocate to interim tables and indexes.

To set the storage parameters:

1. Navigate to the Storage Parameters window.

General Ledger automatically displays all the interim tables and indexes it uses and the corresponding default storage parameters. General Ledger indicates the Object Type (Table or Index) and the Object Name.
2. Enter the Tablespace where you want the interim table or index to reside.
3. Enter the size (in kilobytes) of the Initial Extent you want General Ledger to allocate when it creates the interim table or index.

4. Enter the size (in kilobytes) of the Next Extent you want General Ledger to allocate for the interim table or index. This size is a base value which may remain constant for each subsequent extent, or may change depending on the value you enter for percent increase. The default extent values vary with the individual table or index. To see an explanation for the default value of a particular table or index, refer to the Description.
5. Enter the Maximum number of extents allowed for the interim table or index.
6. Enter the Pctincrease, or percentage for which you want each next extent size to increase over the last extent allocated. If percentage increase is zero (0), then the size of each additional extent remains constant.

Tip: We recommend that you specify a percent increase of either 0 or 100 for your interim tables. Other values can increase the rate of fragmentation of your interim tablespace.

Related Topics

Tablespaces and Segments

(Oracle7 Server Concepts Manual)

Opening and Closing Accounting Periods

Open and close accounting periods to control journal entry and journal posting, as well as compute period-end and year-end actual and budget account balances for reporting.

You can open and close accounting periods in two ways:

- The Open and Close Periods window
- The Open and Close Periods programs

If you have Ledger Sets defined, you can open and close periods for multiple ledgers in a single process using the Open and Close Periods programs.

See: Open and Close Periods Programs, page 1-219.

Accounting periods can have one of the following statuses:

Open: Journal entry and posting allowed.

Closed: Journal entry and posting not allowed until accounting period is reopened. Reporting and inquiry allowed.

Permanently Closed: Journal entry and posting not allowed. You cannot change this period status. Reporting and inquiry allowed.

Never Opened: Journal entry and posting are not allowed. General Ledger assigns this

status to any period preceding the first period ever opened in your calendar, or to any period that has been defined, but is not yet future-enterable. You cannot change this period status.

Future-Entry: Journal entry is allowed, but posting is not. Your period is not yet open, but falls within the range of future-enterable periods you designated when defining your Ledger. You cannot change this period status without using the concurrent process to open the period.

You can open new accounting periods, close accounting periods, reopen closed accounting periods, and open an encumbrance year (if you are using encumbrance accounting).

If you are using the secondary tracking segment with the Closing and Translation option enabled, General Ledger processing is affected. See: Secondary Tracking Segment, *Oracle General Ledger User's Guide*

Note: When you define a new ledger in Accounting Setup Manager, choose carefully the First Ever Opened Period for your ledger. This period will default when you open the first period for your ledger and cannot be changed. Once you open your first accounting period, General Ledger does not allow you to open prior accounting periods.

Additionally, you cannot translate account balances for the first period ever opened. Therefore, we recommend that you open at least one period prior to the first accounting period in which you wish to enter transactions.

Note: The Oracle Workflow Business Event System, introduced in Release 2.6, allows products to seed business events and event subscriptions.

Period Opened, Period Closed, and Period Re-Opened are seeded business events. See: Business Events, page 7-1.

Data Access Sets

The Data Access Set assigned to your responsibility controls whether or not you can change the status of a ledger's accounting period.

Full Ledger Access: You must have read and write access to the ledger and all of its balancing segment values or management segment values to open and close a ledger's periods.

To obtain full ledger access, your data access set must be one of the following types:

- The Full Ledger data access set type that provides read and write access to the ledger

- The Balancing Segment Value data access set type that provides read and write access to all balancing segment values for a ledger using the All Values checkbox
- The Management Segment Value data access set type that provides read and write access to all management segment values for a ledger using the All Values checkbox

Partial Access: If you have read-only access to a ledger or read and write access to some of its balancing segment values and management segment values, you will not be able to open and close its accounting periods. You will only be able to view the status of the accounting periods in the Open and Close Periods window after the First Ever Opened Period has been opened.

Open and Close Periods Window

You can open and close accounting periods for individual ledgers using the Open and Close Periods window.

Prerequisite

- Define your ledger.
- Define periods in your accounting calendar.
- If closing a period, all journals must be posted.

To open the first accounting period:

1. Navigate to the Open and Close Periods window. The Find Periods window will appear.
2. Choose a Ledger from the list of values and select Find. Your data access set must provide read and write access to the ledger and all of its balancing segment value and management segment values to open its first accounting period.
3. For new ledgers that have never been opened, the First Ever Opened period defined for the ledger will default in the Period field and cannot be changed.
4. Select Open. A decision box appears. Select Yes to open the first period in your ledger.

To open subsequent accounting periods:

1. Navigate to the Open and Close Periods window.
The Find Periods window will be displayed.
2. Choose a Ledger from the list of values.

Your data access set must provide read and write access to the ledger and all of its balancing segment values and management segment values to open its accounting periods.

3. Choose the Period Status of the periods you want to find.
Any is the default to indicate any period status.
4. (Optional) Specify a Period, Fiscal Years, or Period Number to find specific periods for the ledger. If you leave these fields blank, all periods will be retrieved.
5. Select Find.
The Open and Close Periods window shows all open and future enterable periods.
6. Choose Open Next Period to open the next period. To confirm that you want to open the next period, select the Yes button in the decision box.

General Ledger launches a concurrent process to calculate the ending and beginning account balances for the current period and subsequent period.

Tip: Although you can have several open accounting periods, to maximize the efficiency of the General Ledger posting process, as well as to minimize the possibility of user error, limit the number of accounting periods that are open at one time.

If you open the first period of a new fiscal year, General Ledger automatically updates the Retained Earnings account.

7. Alternatively, choose Open Target Period, which opens another form to specify the target period. After you select the target period from the LOV, choose Open Period to launch the concurrent request.

After you select the target period from the LOV, click Open Period to launch the concurrent request.

This opens the target period and any prior periods that are between the target period and the latest open period for that ledger.

General Ledger launches a concurrent process to calculate the ending and beginning account balances for the current period and subsequent periods up to the target period.

To close an accounting period:

1. Repeat Steps 1 through 5 above to open subsequent accounting periods.
2. Find the period you want to close. Use the List of Values to change its status to one of the following:

- **Closed:** To prevent entering or posting journals to that period. You can reopen a closed period at any time. A period can only be closed if it is an open period.
 - **Permanently Closed:** To prevent entering or posting journals to that period. You cannot reopen a permanently closed period. A period can only be permanently closed if its status is closed. When you permanently close a period, all prior periods will also be permanently closed for you.
3. Save your work. When you close the window, a concurrent process is submitted. If General Ledger finds unposted journals or data that has not been imported from General Ledger's interface tables for your closed periods, your Close Period request completes with a warning. If you close or permanently close multiple periods, a separate concurrent request is submitted for each closed period.

To reopen an accounting period:

1. Repeat Steps 1 through 5 above to open subsequent accounting periods
2. Choose the Open Period button. Specify a closed period in the Target Period field, and then choose the Open button. You can reopen any closed period that is not permanently closed.

Related Topics

Defining Calendars, page 1-103

Defining Ledgers, page 1-110

Entering Journals, *Oracle General Ledger User's Guide*

Posting Journal Batches, *Oracle General Ledger User's Guide*

Overview of Reporting Currencies, *Oracle General Ledger User's Guide*

Opening an Encumbrance Year

When you open the first period defined for your ledger, General Ledger automatically opens your first encumbrance year as well. When you open additional encumbrance years, General Ledger automatically rolls your project-to-date encumbrance balances forward through the last period of the latest open encumbrance year.

You do not need to open encumbrance years if you are not using encumbrance accounting.

Note: There is no concept of closing encumbrance periods or years. Once you open an encumbrance year, you will always be able to enter and post encumbrance journals to any period up to the latest open encumbrance year.

To open an encumbrance year:

1. Navigate to the Open and Close Periods window.

The Find Periods window appears.

General Ledger automatically displays your Latest Open encumbrance year. You can enter and post encumbrance balances up to the last period of your latest open encumbrance year.

2. Choose a Ledger from the list of values and choose Find.

Your data access set must provide read and write access to the ledger and all of its balancing segment values and management segment values to open its encumbrance year.

Choose Open Next Year. General Ledger submits a concurrent process to open the next encumbrance year.

3. Choose the Period Status of the periods you want to find. Any is the default to indicate any period status.

4. (Optional) Specify a Period, Fiscal Years, or Period Number to find specific periods for the ledger. If you leave these fields blank, all periods are retrieved.

5. Select Find.

The Open and Close Periods window display the latest open encumbrance year.

6. Select Open Next Year.

General Ledger submits a concurrent process to open the next encumbrance year.

Related Topics

Overview of Encumbrance Accounting, *Oracle General Ledger User's Guide*

Entering Encumbrances, *Oracle General Ledger User's Guide*

Opening and Closing Accounting Periods, page 1-214

Setting Up Oracle Purchasing and Oracle Public Sector Purchasing (*Oracle E-Business Suite User's Guide*)
Setting Up Oracle Purchasing and Oracle Public Sector Purchasing (*Oracle E-Business Suite User's Guide*)

Open and Close Periods Programs

You can open and close periods for a single ledger or multiple ledgers in a ledger set with one of the following programs:

- **Periods – Open Periods:** To open periods up to and including the specified target

period for one or more ledgers.

- **Periods – Close Period:** To close a single period for one or more ledgers. Only open periods can be closed.

Note: The Close Period program completes with a warning if unposted journals exist in the period.

- **Periods – Gapless Close Period:** To close a consecutive range of open periods for one or more ledgers. This program closes the specified period and all prior periods that are still open.
- **Periods – Permanently Close Period:** To permanently close one or more closed periods for one or more ledgers. Periods starting from the initial period must be closed before you can permanently close them. To permanently close a range of closed periods, the specified period and any prior periods must have a status of Closed or Permanently Closed.

Caution: When you permanently close a period, all prior periods are also permanently closed and can never be re-opened.

You can schedule your Period programs to run automatically based on schedules you define in Oracle Applications or in General Ledger.

You must have read and write access to the ledger and all of its balancing segment values and management segment values to open and close periods.

Prerequisite

- Define your ledger and ledger sets.

To run the Periods programs:

1. Navigate to the Submit Request window.
2. Choose to Submit a Single Request.
The Submit Request window appears.
3. In the Request Name field, select one of the following Period programs:
 - Period: Open Periods
 - Period: Close Period
 - Period: Gapless Close Period

- Period: Permanently Close Period
4. Complete the following parameters:
 - **Ledger/Ledger Set:** Enter the name of the ledger or ledger set. You can only access ledger sets that are included in your data access set.

Note: You must have read and write access to the ledger and all of its balancing segment values and management segment values to run the Period programs.
 - **Period Name:** Enter the period you want to open, close, or permanently close.
 5. Select OK to close the Parameters window.
 6. Submit the program. A concurrent process is launched.

For a ledger set, the program launches a parent request and separate child requests for each ledger in the ledger set. The parent request execution report outlines all the ledgers that were processed.

Reporting Currencies

If you use reporting currencies (Journal or Subledger Level), you need to open and close the periods for your reporting currencies separately from your ledgers. You can open and close periods for your reporting currencies in the same way that you do for your ledgers by selecting the name of your reporting currency in the Ledger field in the Open and Close Periods window or SRS programs. You can even include your reporting currencies in a ledger set with your other ledgers to open and close periods for all of your ledgers and reporting currencies simultaneously.

Average Daily Balances

If average balance processing is enabled for your ledgers, the Periods – Open Periods program submits two requests per ledger, one for standard balances and another for average balances. If opening an adjusting period, only one process is submitted for standard balances because average balances are not maintained for adjusting periods.

Oracle General Ledger Command Center Setup

This chapter covers the following topics:

- Setting Up General Ledger Command Center
- Setup and Configuration Steps for General Ledger Command Center
- Reviewing Data Access Security Setup for General Ledger Command Center
- Profile Options for General Ledger Command Center
- Loading General Ledger Data

General Ledger Command Center Configuration

Setting Up General Ledger Command Center

See General Ledger Command Center Overview, *Oracle General Ledger User's Guide*.

The General Ledger Command Center configuration setup must be completed after the installation and common configurations are completed as described in My Oracle Support Knowledge Document 2495053.1, *Installing Oracle Enterprise Command Center Framework, Release 12.2*.

See Setup and Configuration Steps for General Ledger Command Center, page 2-2.

Setup and Configuration Steps for General Ledger Command Center

See General Ledger Command Center Overview, *Oracle General Ledger User's Guide*.

Prerequisites

1. Ensure that the *Create Accounting* program is run to create and transfer journal entries. Set the *Transfer to General Ledger* parameter to Yes to populate journal entries in the GL_INTERFACE table.
2. Check the *SLA: Disable Journal Import* profile option. It must be set to Yes to load interface lines to the ECC data store.

Complete the following steps to set up the General Ledger Command Center:

1. Review the data access security that is setup for the General Ledger Command Center, page 2-2.
2. Set profile options, page 2-3.
3. Load the General Ledger data, page 2-5.

Reviewing Data Access Security Setup for General Ledger Command Center

See Setup and Configuration Steps for General Ledger Command Center, page 2-2.

The General Ledger Command Center uses the same data access security mechanisms as Oracle General Ledger.

The following data access security mechanisms apply:

- GL: Data Access Set profile option: The command center displays data for a ledger

or ledgers based on the value that is set for the GL: Data Access Set profile option. See *General Ledger Profile Options, Oracle General Ledger Reference Guide*.

- Data access sets: Data access sets control the ledgers that users with different responsibilities can access. Data access sets can also limit a user from accessing certain balancing segment values or management segment values or grant read-only or read and write access to data in a ledger. See *Data Access Sets*, page 1-118.

Important: Security rules affect the calculation of metrics and the plotting of charts, which use only the data to which the user has access. When implementing the command center, you must consider the security structure and ensure that the concerned financial team members have appropriate access to the General Ledger data. If security is not set up correctly, then the General Ledger data and any calculation based on that data may be incorrectly displayed for the given user.

Profile Options for General Ledger Command Center

See *Setup and Configuration Steps for General Ledger Command Center*, page 2-2.

You must set the following profile options before you run the data load concurrent program.

Profile Option Name	Description
FND: KFF Hierarchy Level for ECC	<p>This site-level profile option controls the number of hierarchy levels of the <i>Natural Account</i> segment that are loaded to the ECC data store and displayed on the following components:</p> <ul style="list-style-type: none"> • Account Analysis dashboard: Period Activities by Account Hierarchy table of the Account Analysis dashboard. • Balances dashboard: YTD Balances and Detailed Trial Balance tabs. <p>If no value is set, then 15 levels of hierarchy are loaded to the ECC data store.</p> <p>Define the profile option value depending on the levels of hierarchy set up in the chart of accounts in your enterprise. For example, if there are five levels of hierarchy set in your chart of accounts, then enter 5.</p> <p>Important: Oracle recommends that you base the profile value on your business requirements and must consider the volume of data and ECC performance.</p>
GL: Number of Latest Open Periods for ECC	<p>This site-level profile option controls the number of latest open periods that get displayed by default on the dashboard.</p> <p>This profile option is applicable to the following dashboards:</p> <ul style="list-style-type: none"> • Account Analysis • Journal Processing • Balances <p>The default value is 2. You can change the profile value as required. If the profile option is blank, then the default value is considered.</p>

Loading General Ledger Data

See Setup and Configuration Steps for General Ledger Command Center, page 2-2.

To load the data from Oracle E-Business Suite to the General Ledger Command Center data sets, run the *General Ledger Command Center Data Load* concurrent program, which is located under **General Ledger Super User >Other >Requests**.

This program loads the following data sets based on the load rule of each data set.

Data Set Name	Description	Associated General Ledger Command Center Dashboard	Applicable Load Type
gl-aa	GL Account Analysis	Account Analysis	Full Load and Incremental Load
gl-imp	GL Journal Import	Journal Processing	Full Load
gl-ab	GL Balances	Balances	Full Load and Incremental Load

Note: This program loads data only for primary ledgers, open accounting periods, and the Actual balance type. To load data for the gl-imp data set, the program considers interface lines that are not in the Processed status.

Prerequisite Step: To load data for a specific ledger or ledgers, note the ledger IDs before you run the data load.

Run the concurrent program from the **Submit Request** window.

General Ledger Command Center Data Load

The screenshot shows a software interface for submitting a request. The main window is titled 'Submit Request' and contains a 'Run this Request' section with a 'Copy' button. Below this, there are input fields for 'Name' (containing 'General Ledger Command Center Data Load'), 'Operating Unit', 'Parameters', and 'Language' (set to 'American English'). A secondary 'Parameters' dialog box is overlaid on top, containing the following fields: 'Load Type' (highlighted), 'Data Set', 'Languages', 'Log Level', 'SQL Trace', 'Ledger ID' (highlighted), and 'Set/Reset Data'. The 'Parameters' dialog box has 'OK', 'Cancel', 'Clear', and 'Help' buttons at the bottom.

To load General Ledger data:

1. In the **Name** field, select **General Ledger Command Center Data Load**.
2. Select the appropriate load type.
 - **Full Load:** Loads all General Ledger data and must be run for the first data load.
 - The full load option performs a complete data reset and loads data only for the open accounting periods. If an accounting period is closed, then the data for that period is not loaded to the ECC data store.
 - If you select the gl-imp data set to load data for the Journal Processing dashboard, then you must select the full load option as the load type.

Important: If you transfer a transaction that is in the subledger, then you must run the data load program with the full load option only.

- **Incremental Load:** Loads only the data that has been modified since the previous load.
 - The incremental load type does not apply to the gl-imp data set.
 - For the gl-aa data set, if you select the incremental load type and an

accounting period is closed, then transactions that belong to the closed period are deleted from the data set.

- **Metadata Load:** Loads Descriptive Flexfield (DFF) metadata.
3. In the **Languages** field, enter one or more language codes for the output. For multiple language codes, use the format AA,BB,NN. If the field is blank, then the data will be loaded for the base language only (usually US).
 4. Select the log level that you want the program to report. The default value is Error.
 5. Select **True** to enable SQL trace. Otherwise, select **False**.
 6. In the **Ledger ID** field, enter the ID of the ledger for which you want to load data. If there are multiple ledgers for data load, then enter the ledger IDs using comma.
 7. Use the **Set/Reset Data** parameter with caution.
 - If you run full load for the first time or want to reset the data, then set the parameter value to TRUE. If set to TRUE, this action wipes out all the data that was loaded earlier and loads the new data for the selected ledger or ledgers. After the completion of full load, data of only the selected ledger or ledgers will be available in the ECC data store.
 - For subsequent full loads, to append the new data to the data set, set the parameter value to FALSE.
 - For incremental loads, you need not select a value, because the value is always FALSE.
 8. Submit the concurrent request.
 9. Review your request using the **Requests** page.
 10. Monitor data loading using the **Data Load Tracking** page of the ECC Developer responsibility.

Integrating with Oracle Fusion Applications

Overview of Oracle Fusion Applications

Oracle Fusion Applications are a modular suite of applications designed to work as a complete solution or as modular extensions to your existing financial applications portfolio. This chapter covers integration points between Oracle Fusion Accounting Hub and Oracle General Ledger.

Overview of Oracle General Ledger and Oracle Fusion Accounting Hub Integration

The Oracle Fusion Accounting Hub provides integration for the Oracle General Ledger.

Important: To use this integration you must first install Oracle GoldenGate, see Note 1324692.1 on My Oracle Support, *Configure Oracle GoldenGate to Integrate the E-Business Suite Ledger with the Fusion Accounting Hub*.

This integration provides you with the opportunity to leverage the Oracle Fusion Accounting Hub with minimal implementation effort and without disruption to your current financial management processes. You can continue to use Oracle E-Business applications for your procure-to-pay and the credit-to-collections processes without disruption and you can also continue to account for transactions in Oracle General Ledger without changing their accounting treatments.

Integration between the Oracle Fusion Accounting Hub and Oracle General Ledger includes the ability to transfer full or incremental period balances to the Fusion General Ledger. You can convert charts of account values and accounting period information to align with Fusion ledger configurations. You can also drill from the summary information posted in the Fusion Accounting Hub back to the Oracle E-Business Suite (EBS).

The integration requires the following:

- Setting up basic mapping between Oracle E-Business Suite and Oracle Fusion.
- Transferring balances between Oracle E-Business Suite and Oracle Fusion, which is done through concurrent programs.

This section covers the following:

- Setting Up Calendar Mapping, page 3-2
- Setting Up Ledger Mapping, page 3-3
- Transferring Balances, page 3-4
- Drilling from Oracle Fusion General Ledger to Oracle General Ledger, page 3-5
- Setting Profile Options, page 3-6

Within Oracle General Ledger, you can access setup windows for the Oracle Fusion Accounting Hub from the Fusion Coexistence Mapping menu. To find this menu in Oracle General Ledger, navigate to (N) Setup > Financials menu.

Setting Up Calendar Mapping

You can use calendar mapping functionality to transform the balance transfer journals period information from the E-Business Suite to Fusion.

Note: The Oracle E-Business Suite calendar and the Oracle Fusion Applications calendar must use the same functional currency.

Example

Convert an EBS period of January 2010 to a Fusion period of Quarter 1 2010.

This is useful if there is a consolidated ledger in Fusion that uses a different period. You can create calendar mappings within Oracle General Ledger by using the Calendar Mappings window.

You will select an E-Business Suite calendar and a Fusion calendar; then map periods between the two.

Note: If you do not use a calendar map, the GL date on the balance transfer is compared to the Fusion calendar associated with the Fusion ledger to determine the GL period.

You can create calendar mappings in Oracle General Ledger by selecting Calendar from the Fusion Coexistence Mapping menu.

To create a calendar mapping:

1. Navigate to the Calendar Mappings page.
2. Select Create.
3. In the Name field, enter a name for your mapping.
4. Select a calendar from the E-Business Calendar LOV.
5. Select a calendar from the Fusion Calendar LOV.
6. Optionally, enter a description.
7. Select a period type from the E-Business Suite Period Type LOV.
8. Update the calendar mappings in the Map Periods section, for example, enter Jan-10-10 in the E-Business Suite Calendar Period field and Q1-10 in the Fusion Calendar Period field.
9. Select Apply.

ORACLE Fusion Coexistence Mapping

Calendar Mappings >
Create Calendar Mapping
Calendar mappings are used to assign GL periods during the balance transfer process from EBS to Fusion. Cancel Apply

Calendar Mapping

* Indicates required field

* Name: Monthly to Quarterly
Description: EBS Monthly to Fusion Quarterly

* E-Business Suite Calendar: 15 Period
* E-Business Suite Period Type: 15 Period

* Fusion Calendar: AccountingQuart

Map Periods

Add or update the calendar mapping period assignments.

E-Business Suite Calendar			Fusion Calendar		
Period	Start Date	End Date	Period	Start Date	End Date
Jan-10-10	01-Jan-2010	31-Jan-2010	Q1-10	01-Jan-2010	31-Mar-2010

Setting Up Ledger Mapping

Ledger Mapping allows you to create pairings of E-Business Suite and Fusion ledgers to route the balance transfer journals. When you create a ledger mapping, you can select a calendar map and/or a chart of accounts map. The calendar and chart of accounts mapping converts values during the balance transfer. The mapped values are used on the balance transfer journals.

You can map multiple EBS ledgers to the same Fusion ledger.

You can create ledger mappings in Oracle General Ledger by selecting Ledger from the Fusion Coexistence Mapping menu.

To set up ledger mapping:

1. Navigate to the E-Business Suite - Fusion Ledger Mappings page.
2. Select Create.
3. Select a ledger from the E-Business Suite Ledger LOV.
4. Select a ledger from the Fusion Ledger LOV.
5. Optionally, select a mapping from the Accounting Calendar Mapping LOV.
6. Optionally, select a mapping from the Chart of Accounts Mapping LOV.

Note: If you do not select an accounting calendar or chart of accounts mapping, then the Fusion ledger uses the same values as the E-Business Suite ledger for the calendar period and the chart of accounts values.

The screenshot shows the Oracle Fusion Coexistence Mapping interface. The page title is "ORACLE Fusion Coexistence Mapping". The breadcrumb trail is "E-Business Suite - Fusion Ledger Mappings > Create Ledger Mapping". There are navigation links for "Navigator", "Favorites", "Diagnostics", "Home", "Logout", and "Preferences". A note states "* Indicates required field". The form contains four fields: "* E-Business Suite Ledger" (set to "Vision Operations (USA)"), "* Fusion Ledger" (set to "Vision Operations (USA)"), "Accounting Calendar Mapping", and "Chart of Accounts Mapping". Each field has a search icon. There are "Cancel" and "Apply" buttons at the bottom right of the form.

Transferring Balances

You can transfer balances for either:

- The total balance for an E-Business Suite period.
- The change in balance for the E-Business Suite period since the last balance. This is known as an incremental transfer.

Each time you run the balance transfer program, a journal is created in the Fusion General Ledger. To complete the balance transfer, run the Fusion Balance Transfer – Full or the Fusion Balance Transfer - Incremental programs from Oracle General Ledger. These programs generate a report that details the total amounts transferred and the exceptions.

To run the Fusion Balance Transfer - Full program:

1. From the Submit Requests form, select Fusion Balance Transfer - Full program.

2. In the Parameters window, select:
 - From Ledger
 - From Period
3. Select OK.
4. Select Submit.

To run the Fusion Balance Transfer - Incremental program:

1. From the Submit Requests form, select Fusion Balance Transfer - Incremental program.
2. In the Parameters window, select a ledger from the Ledger LOV.
3. Select OK.
4. Select Submit.

Successfully transferred rows are not removed from the interface table on either the Fusion or the E-Business Suite side. To remove these rows, run the Fusion Balance Transfer - Purge Interface program. This program will remove successfully transferred rows from the interface table in both Fusion and E-Business Suite. It will not remove rows that have not yet been successfully transferred.

To run the Fusion Balance Transfer - Purge Interface program:

1. From the Submit Requests form, select Fusion Balance Transfer - Purge Interface program.
2. Select OK.
3. Select Submit.

Drilling from Oracle Fusion General Ledger to Oracle General Ledger

You can drill from Oracle Fusion General Ledger to Oracle General Ledger in order to audit balance transfer journals that record Oracle General Ledger balances. This is done with a balance inquiry in the Fusion General Ledger, using the Account Monitor from the General Accounting Manager dashboard.

For more information refer to the *Oracle Fusion Applications Financial Control and Reporting, Accounting Transactions, Tax Transactions, and Reporting Guide*.

Setting Profile Options

The following profile options affect how Oracle General Ledger communicates with Oracle Fusion Applications:

- **GL: Applications Coexistence Fusion User:** Set this profile to the Fusion user to be associated with the Fusion balance transfer programs. The programs will run with the privileges and access of this user. To access the Fusion files and execution reports, you must log in as the user defined within this profile.
- **GL: Applications Coexistence System Identifier:** Set this profile to the system identifier of this EBS system as registered on the Fusion system.

Integrating Hyperion Data Relationship Management (DRM) with Oracle General Ledger

Overview of Hyperion Data Relationship Management

Oracle Hyperion Data Relationship Management (DRM), Fusion Edition functions as a master data management solution where reporting structures are maintained, analyzed, and validated before moving throughout the enterprise. Data Relationship Management does the following:

- Manages business entities, hierarchies, attributes, and mappings across multiple systems.
- Validates data relationships and calculates attribute values using business rules.
- Enforces referential integrity across all subscribing systems and hierarchies.
- Enables you to create and manage alternate views.
- Merges independent data sets from different sources and combines them into a master set.
- Maintains historical versions for comparative reporting and analysis.
- Tracks all hierarchy and attribute changes with a full-featured audit log.
- Can serve as the main point-of-entry to update subscribing systems or be used subsequently for reconciliation and analysis.

You can use Data Relationship Management to manage charts of accounts segment values and hierarchies for Oracle General Ledger. You can create new segment values, edit their properties, and maintain hierarchies using DRM. This information can be

synchronized to one or more general ledger instances using a concurrent request program in the Oracle E-Business Suite.

For more information on how to use Data Relationship Management, see the *Oracle Hyperion Data Relationship Management, Fusion Edition, Oracle General Ledger Integration Guide*.

Explaining DRM Configurations

You must complete configuration setups in Oracle Hyperion DRM in order to integrate with the Oracle Fusion General Ledger and the Oracle E-Business Suite (EBS) General Ledger. These setups are typically completed by an administrative user.

1. Create a DRM user.
2. Load metadata by uploading the application template.
3. Update the external connections to the Oracle E-Business Suite and Oracle Fusion General Ledger instances.

For more information refer to the *Oracle Hyperion Data Relationship Management, Fusion Edition, Oracle General Ledger Integration Guide* and the *Hyperion Data Management Integration with the Oracle Fusion and E-Business Suite General Ledgers White Paper*, Note 1315694.1 on My Oracle Support.

Configuring Oracle General Ledger

You must perform the following configuration steps in each Oracle General Ledger instance with which you are integrating Data Relationship Management.

- Set system profile values, page 4-2.
- Populate the Data Relationship Management password, page 4-6.

Setting System Profile Values

You must set several system profile options. The following table provides details about each option.

Profile Option	Description
----------------	-------------

GL: DRM Username

Set this site-level profile option to the user name for the Data Relationship Management user created during the configuration. This profile option applies only to E-Business Suite.

GL: DRM Property for Value Set Name

Set this profile option to be equal to the property that was created in Data Relationship Management to hold the value of the alternate value set for the instance which is being updated. This profile option stores the name of the version-level property in Data Relationship Management, which supplies the value set name for an instance. For example, suppose ACME Corporation creates a Data Relationship Management property entitled, UK Value Sets to link its United Kingdom general ledger value sets to Data Relationship Management versions. In this case, the profile option is UK Value Sets.

Note: This step is required only if you need to store alternate names for value sets with Data Relationship Management versions

GL: DRM Property to Allow Version Export

This profile option indicates whether to export values to an instance. If you are exporting to only one general ledger, the default values for this property are correct and do not need to be changed. If you are exporting to multiple general ledgers, then copy the exports provided by Oracle General Ledger as described *Configuring Data Relationship Management Metadata for Oracle General Ledger* chapter of the *Oracle Hyperion Data Relationship Management, Fusion Edition, Oracle General Ledger Integration Guide*. Use the names for the respective exports that you created for the value set and hierarchy exports.

GL: DRM Property to Allow Hierarchy Export

This profile option indicates whether to export a hierarchy to an instance. If you are exporting to only one general ledger, the default values for this property are correct and do not need to be changed. If you are exporting to multiple general ledgers, then copy the exports provided by Oracle General Ledger as described in the *Configuring Data Relationship Management Metadata for Oracle General Ledger* chapter of the *Oracle Hyperion Data Relationship Management, Fusion Edition, Oracle General Ledger Integration Guide*. Use the names for the respective exports that you created for the value set and hierarchy exports.

GL: DRM API Adapter URL

Set this profile option to the URL of the Data Relationship Management API Adapter. The Data Relationship Management instance exposes its Web Service operations through this URL.

GL: DRM WSDL URL

Set this profile for the DRM WSDL for use by the E-Business Suite Services Invocation Framework (SIF) in accessing the DRM web service. SIF validates the SOAP requests against this WSDL and also derives the endpoint URL (the web service URL).

GL: DRM Template for Hierarchy Export

Set this profile to specify which DRM export to use for hierarchy export.

If you are exporting to multiple EBS general ledgers, then you should have copied the hierarchy export provided by Oracle (the process for this is described in the Hyperion DRM configuration section of the *Hyperion Data Management Integration with the Oracle Fusion and E-Business Suite General Ledgers White Paper*, Note 1315694.1 on My Oracle Support).

Example

Your company has two EBS instances, North America and the United Kingdom and you want to integrate with DRM. You can use the default hierarchy export provided by Oracle for one of the instances, such as the North America instance. For this instance you will leave the default value for the profile option GL: DRM Template for Hierarchy Export. You must both create and name a new export in DRM for the United Kingdom instance, since exports are connected to specific databases. You then update the value for the profile option GL: DRM Template for Hierarchy Export to use the name of the export that you created.

GL: DRM Template for Version Export

Set this profile to specify which DRM export to use for version export.

If you are exporting to multiple EBS general ledgers, then you should have copied the value set export provided by Oracle (the process for this is described in the Hyperion DRM configuration section of the *Hyperion Data Management Integration with the Oracle Fusion and E-Business Suite General Ledgers White Paper*, Note 1315694.1 on My Oracle Support).

Example

If your company has two EBS instances, North America, and the United Kingdom and you want to integrate with DRM. You can use the default value set export provided by Oracle for one of the instances, such as the North America instance. For this instance, you leave the default value for the profile option GL: DRM Template. However, you must create and name a new export in DRM for the United Kingdom instance, since exports are connected to specific databases. You then update the value for the profile option GL: DRM Template for Version Export to use the name of the export that you created.

Populating the Data Relationship Management Password

The Data Relationship Management password must be stored in Oracle E-Business Suite to enable access to Data Relationship Management when loading values and hierarchies. You populate the Data Relationship Management password in E-Business Suite by running a script. This script is stored in FND_VAULT.

The script is run as:

```
sqlplus apps/apps@db @$FND_TOP/sql/afvltput.sql SQLGL <KEY> <VALUE>
```

The table below describes the two parameters used in the script:

Parameter	Value
-----------	-------

Key	The name of the DRM user stored in the profile option: GL: DRM Username
Value	The DRM password for the user identified in the profile option: GL: DRM Username

Loading Values from the Oracle E-Business Suite to DRM

Oracle E-Business Suite provides an initialization program that is run from Oracle General Ledger.

Note: This step is only required if you would like to start using DRM with EBS value set values and hierarchies (parent-child relationships).

The Initialize Segment Values and Hierarchies program is run from each general ledger instance to output data for loading into DRM. Each request can extract one value set of segment values and hierarchies. When you select the Initialize Segment Values and Hierarchies program from the Submit Request window, you will then be prompted to select a value from the Value Set Name field within the Parameters window. Request sets can be created to run the request for multiple value sets.

The Oracle General Ledger application template includes an import profile to load the import file produced by the E-Business Suite initialization program. The following Data Relationship Management import profile is included in the application template:

- **EBSValueSetImport:** Loads data created by the Initialize Segment Values and Hierarchies concurrent request program in E-Business Suite

Using DRM as a master data management solution may require data cleansing to transition from disparate sources of information for charts of accounts to a single, unified application. The data cleansing is completed in DRM.

For more information refer to the *Oracle Hyperion Data Relationship Management, Fusion Edition, Oracle General Ledger Integration Guide* and the *Hyperion Data Management Integration with the Oracle Fusion and E-Business Suite General Ledgers White Paper*, Note 1315694.1 on My Oracle Support.

Loading Segment Values and Hierarchies into Oracle General Ledger

Chart of accounts segment values and hierarchies are loaded from Data Relationship Management into Oracle General Ledger using a concurrent request program. The Load Segment Values and Hierarchies request is run from each general ledger instance to retrieve data from Data Relationship Management. Each request can load one value set of segment values and hierarchies. When you select the Load Segment Values and

Hierarchies program from the Submit Request window, you will then be prompted to select a value from the Value Set Name field within the Parameters window. Request sets can be created to run the request for multiple value sets.

The Load Segment Values and Hierarchies request will only create or update segment values and hierarchies for the chart of accounts accessible through your general ledger data access setting. The request also requires that only one Data Relationship Management version is defined as the master for each value set using the Value Set Master property.

An accompanying report for the Load Segment Values and Hierarchies request indicates whether the load into Oracle General Ledger is successful and provides summary information about the information imported from Oracle Hyperion Data Relationship Management, Fusion Edition.

Data Relationship Management node types are automatically enabled for hierarchies that are imported from Oracle General Ledger. New hierarchies that are created directly in Data Relationship Management will not have Oracle General Ledger node types enabled without additional configuration.

You must perform one of the following actions to enable node types for new hierarchies to be exported to Oracle General Ledger:

- Assign OracleGL.NodeType as the default value of the Hierarchy Node Type property definition in the Core namespace. This configuration will enable node types for all hierarchies using the Node Type property in the OracleGL namespace. This task can be performed by an application administrator only.
- Select the Node Type property from the OracleGL namespace for the value of the Hierarchy Node Type property in the System category for each new hierarchy created.

For more information refer to the *Oracle Hyperion Data Relationship Management, Fusion Edition, Oracle General Ledger Integration Guide*.

Using DRM to Manage Segment Values and Hierarchies for Oracle General Ledger

The Data Relationship Management data model is significantly different from that of the Oracle E-Business Suite. Data Relationship Management groups multiple hierarchies consisting of multiple nodes into one or more versions, whereas Oracle E-Business Suite has multiple chart of accounts value sets (segments), each with segment values (nodes). For an example comparing the Oracle General Ledger and Data Relationship Management data models refer to the *Managing Segment Values and Hierarchies for Oracle General Ledger* chapter in the *Oracle Hyperion Data Relationship Management, Fusion Edition, Oracle General Ledger Integration Guide*.

Improving General Ledger Performance

Improving General Ledger Performance

There are many ways you can improve General Ledger's performance and processing times for programs, such as the Maintain Summary Templates, Journal Import, and MassAllocation/MassBudget programs.

The following two programs improve General Ledger's performance:

Maintain Summary Templates Program: updates summary account information in the current ledger.

Optimizer Program: create or drop indexes for those segments in your chart of accounts that you have marked for indexing.

You can improve the performance of the Journal Import, and MassAllocation/MassBudget programs by setting the following profile options:

1. **GL: Number of Accounts in Memory:** affects the performance of your MassAllocation and MassBudget programs
2. **GL: Number of Records to Process at Once:** affects the performance of your Journal Import, MassAllocation and MassBudget programs.

Related Topics

Running the Maintain Summary Templates Program, page 5-2

Running the Optimizer Program, page 5-2

Setting Profile Options for Concurrent Program Performance, page 5-4

Optimizing Performance by Creating Indices on GL_CODE_COMBINATIONS Table, page 5-5

Running the Maintain Summary Templates Program

Run the Maintain Summary Templates program to update summary account information for one or more ledgers. This program ensures that your summary account templates reflect any new detail accounts you may have added.

Although General Ledger maintains summary templates automatically during the posting process, running the Maintain Summary Templates program before posting can improve the performance of the posting program. This is especially useful if you have added several new detail accounts since your last posting operation.

Prerequisites

- See: Defining Summary Accounts, page 1-186.

To run the Maintain Summary Templates program:

1. Navigate to the Submit Request window.
2. Select the Maintain Summary Templates program.
3. Select a value from the Ledger LOV.
4. Submit the report.

Related Topics

Running Reports and Programs, *Oracle Applications User's Guide*

Defining Key Flexfields, *Oracle Applications Flexfields Guide*

Defining Segment Values, *Oracle Applications Flexfields Guide*

Defining Summary Accounts, page 1-186

Running the Optimizer Program

Run the General Ledger Optimizer program to create or drop indexes for those segments in your chart of accounts that you have marked for indexing.

You can also update statistical information about your data, such as the size of your balances and combinations tables, the number of accounts with a particular segment value, and the number of account balances associated with each accounting period. This information improves the performance of your journal entry posting and financial reporting process.

To keep these statistics current, you should run the Optimizer at least once a period, or any time you add several segment values, define a new chart of accounts, or add or

delete summary templates.

Prerequisites

- Define your account segments.
- Specify whether you want to index a particular segment in your chart of accounts using the Key Flexfield Segments window.
- Define your account segment values.
- Define summary templates.

To create and drop indexes for your chart of accounts:

1. Freeze your account structure.
2. Navigate to the Submit Request window.
3. Select the Optimizer program.
4. Enter *Yes* for Maintain Indexes to create or drop the indexes for your chart of accounts.

The Optimizer creates an index on a segment if one does not yet exist, and drops an index on a segment if you no longer index the segment. This is useful when you define a new chart of accounts for which you want to index particular segments or when you want to add or drop an index for an existing segment in your chart of accounts.

To update statistical information about your data:

1. Navigate to the Submit Request window.
2. Select the Optimizer program.
3. Enter *Yes* for Gather Statistics. The Optimizer program gathers and updates statistical information about the size of your balances and combinations table, the number of account combinations with a particular segment value, and the number of account balances associated with each accounting period.

Related Topics

Running Reports and Programs, *Oracle Applications User's Guide*

Defining Key Flexfields, *Oracle Applications Flexfields Guide*

Defining Segment Values, *Oracle Applications Flexfields Guide*

Setting Profile Options for Concurrent Program Performance

You can improve the performance of the Journal Import, and MassAllocation/MassBudgeting programs by setting the profile options GL: Number of Accounts in Memory and GL: Number of Records to Process at Once. For example, you can speed Journal Import by increasing the number of records to process at once by increasing the number assigned to the GL: Number of Records to Process at Once profile option.

The profile option GL: Number of Accounts in Memory affects the performance of your MassAllocation and MassBudget programs. The default for this profile option is 2500 to indicate that those programs will process 2500 accounts at once.

The profile option GL: Number of Records to Process at Once affects the performance of your Journal Import, MassAllocation and MassBudget programs. The default for this profile option is 1000 to indicate that 1000 records will be processed at once.

By increasing the number assigned to these profile options, you increase the amount of memory the Journal Import or MassAllocation/MassBudgeting programs can use, thereby increasing their throughput

Prerequisites

1. Run the Optimizer program to create indexes on segments of your account.
2. Determine the amount of your computer's memory that you want to allocate to concurrent programs.

To Set Your Profile Options

1. 1. Navigate to the System Profile Values window from the System Administrator responsibility.
2. 2. Query the profile option GL: Number of Accounts in Memory and/or the GL: Number of Records to Process at Once.
3. 3. Set the profile option at the Site, Application, Responsibility, or User level.
4. 4. Save your work.

See Also

1. Running the Optimizer Program, page 5-2

2. Defining Key Flexfields
3. Importing Journals, *Oracle General Ledger User's Guide*

Optimizing Performance by Creating Indices on GL_CODE_COMBINATIONS Table

To optimize performance you can add a non-unique concatenated index on just the active segments of the GL_CODE_COMBINATIONS table.

To determine which columns must be in the concatenated index, use the following SQL statement (Assume active segments are from 1 through 6.).

```
SELECT idfs.application_column_name FROM gl.gl_ledgers gl, ledger, applsys.  
fnd_id_flex_segments idfs WHERE ((gl.ledger.chart_of_accounts_id = idfs.  
id_flex_num) AND (gl.ledger.NAME = '&LedgerName')) AND (idfs.application_id  
= 101) AND (idfs.id_flex_code = 'GL#') ORDER BY idfs.segment_num ASC;
```

To find what indexes you already have, use the following SQL statement:

```
SELECT aic.index_name, aic.column_name, aic.column_position FROM  
all_ind_columns aic, all_indexes ai WHERE ai.index_name = aic.index_name AND  
ai.table_name = 'GL_CODE_COMBINATIONS' ORDER BY aic.index_name, aic.  
column_position
```

It is also recommended that you create single segment indices on individual segments that are selective. However, you should not create a single segment index on the segment with which the concatenated index starts.

Function Security

Function Security in General Ledger

Use function security to control user access to General Ledger functions. By default, access to General Ledger functionality is NOT restricted; you must ask your system administrator to customize your responsibilities to restrict access. Your system administrator customizes each responsibility at your site by including or excluding registered functions and menus of functions for a responsibility in the Responsibilities window.

The following are common results that may occur when function security is enforced:

- Window or menu does not appear in the Navigator window
- Button is hidden
- Field cannot be updated
- Alternative or tab region is hidden

Use function security to control any of the General Ledger functions shown in the table below:

Function Security

User Function Name	Restrictions
Journal Batches and Journal Entries:	
AutoAllocation Workbench: General Ledger	Creating and changing Oracle General Ledger allocation definitions.

User Function Name	Restrictions
AutoAllocation Workbench: Projects	Creating and changing Oracle Projects allocation definitions.
AutoPost Criteria	Entering or changing AutoPost criteria sets.
Define Recurring Journal Formula	Defining recurring journal entry formulas.
Define MassAllocations	Defining MassAllocation formulas.
Enter Encumbrances	Entering and updating encumbrance entries.
Enter Journals	Creating, entering, and changing journal entries and journal batches.
Enter Journals: Post	Posting journal entries and journal batches from the Enter Journals window.
Journal Entry Inquiry	Inquire on journals and journal batches.
Enter Journals: Reverse	Reversing journal entries and journal batches from the Enter Journals window.
Generate AutoAllocation	Generating AutoAllocation sets.
Generate AutoAllocation: Run Budget Formula Request	Generating budget formulas in AutoAllocation sets.
Generate AutoAllocation: Run MassAllocation Request	Generating MassAllocation formulas in AutoAllocation sets.
Generate AutoAllocation: Run Recurring Journal Request	Generating recurring journal formulas in AutoAllocation sets.
Generate AutoAllocation: Run AutoAllocation Request	Generating AutoAllocation sets.
Generate AutoAllocation: Schedule MassAllocation Requests	Scheduling MassAllocation formulas in AutoAllocation sets.
Generate AutoAllocation: Schedule MassBudget Requests	Scheduling MassBudget formulas in AutoAllocation sets.

User Function Name	Restrictions
Generate AutoAllocation: Schedule Budget Formula Requests	Scheduling budget formulas in AutoAllocation sets.
Generate AutoAllocation: Schedule Recurring Journal Requests	Scheduling recurring journal formulas in AutoAllocation sets.
Generate MassAllocations	Generating MassAllocation journal entries and journal batches based on a MassAllocation definition.
Generate Recurring Journals	Generating recurring journal entries and journal batches from a recurring journal definition.
Reversal Criteria	Entering or changing journal reversal criteria sets.
View AutoAllocation Status	Viewing and monitoring the status of Oracle General Ledger AutoAllocation definitions.
View PA AutoAllocation Status	Viewing and monitoring the status of Oracle Projects AutoAllocation definitions.
Reconciliation	Reconciling journal lines that net to zero.
Reverse Reconciliation	Reversing reconciliation of journal lines.
Post Journals	Posting journal entries and journal batches.
Reverse Journals	Reversing journal entries and journal batches.
Journal Import:	
Correct Journal Import Data	Making corrections to journal entries and journal batches after Journal Import errors occur.
Delete Journal Import Data	Deleting journal entries and journal batches after Journal Import errors occur.
Import Journals	Importing journal entries and journal batches.

User Function Name	Restrictions
Budgets:	
Budget Transfer	Transferring budget amounts from one account to another.
Calculate Budget Amounts	Calculating budget amounts.
Define Budget	Defining or modifying budgets.
Define Budget Formula	Defining budget formulas.
Define Budget Organization	Defining or modifying budget organizations.
Define MassBudgets	Defining MassBudget formulas.
Enter Budget Amounts	Entering or changing budget amounts.
Enter Budget Journals	Entering or changing budget journals.
Freeze Budgets	Freezing and unfreezing budgets.
Generate MassBudgets	Generating MassBudget journal entries and journal batches based on a MassBudget definition.
Upload Budgets	Uploading budget amounts to the budget interface table.
Budgetary Control:	
Budgetary Control Transactions	Entering budgetary control transactions.
Budgetary Control Group	Creating or modifying budgetary control groups.
Consolidations:	
Consolidation Definitions: Allow Any Definition	Creating or changing any consolidation definition.
Consolidation Definitions	Allow any definition.

User Function Name	Restrictions
Consolidation Sets	Creating or changing consolidation definitions for any subsidiary.
Consolidation Workbench	Accessing and using the Consolidation Workbench functions.
Consolidation Workbench: Post	Posting consolidation journals.
Consolidation Workbench: Translate	Updating subsidiary translations from the Consolidation Workbench.
Consolidation Workbench: Translate for Subsidiaries	Parent updating translations for its subsidiaries.
Elimination Sets	Creating or changing elimination formulas.
Generate Eliminations	Generating elimination formulas.
Purge Consolidation Audit Data	Purging consolidation audit data.
Transfer Consolidation Data Set	Transferring subsidiary data to the parent via a transfer set.
Transfer Consolidation Data	Transferring subsidiary data to the parent.
Multiple Currencies:	
Currencies	Creating and enabling currencies.
Conversion Rate Types	Creating or changing conversion rate types.
Daily Rates	Entering or changing daily exchange rates.
Historical Rates	Entering or changing historical exchange rates.
Revaluation	Revaluing account balances.
Translate Balances	Translating account balances.
Daily Rates (Currency Rates Manager)	Entering or changing daily exchange rates.

User Function Name	Restrictions
Historical Rates (Currency Rates Manager)	Entering or changing historical exchange rates.
Rate Types (Currency Rates Manager)	Entering or changing daily exchange rates.
Search Cross Rate Rules (Currency Rates Manager)	Searching cross rates.
Define Cross Rate Rules (Currency Rates Manager)	Creating or changing cross rates.
Online Inquiry and Reporting:	
Account Inquiry	Performing account balance inquiries.
Account Inquiry: Consolidation Drilldown	Drilling down to subsidiary data during an account inquiry.
Account Inquiry: Move/Merge Source Drilldown	Drilling down on Move/Merge sources during an account inquiry.
Account Inquiry: Subledger Drilldown	Drilling down to subledger details during an account inquiry.
Average Balance Inquiry	Performing average balance inquiries.
Budget Inquiry	Performing budget inquiries.
Funds Available Inquiry	Performing a funds availability inquiry.
Revaluation: Submit	Submitting revaluation from Standard Request Submission window.
Run Requests	Running standard programs and reports, and scheduling FSG reports.
Financial Statement Generator (FSG):	
Autocopy	Autocopying FSG components.
Column Set	Creating and changing column sets.

User Function Name	Restrictions
Content Set	Creating and changing content sets.
Database Links	Creating and changing database links.
Display Group	Creating and changing display groups.
Display Set	Creating and changing display sets.
Financial Report	Creating and changing FSG reports.
Financial Report Set	Creating and changing FSG report sets.
Row Order	Creating and changing row orders.
Row Set	Creating and changing row sets.
Run Financial Reports	Generating FSG reports.
Setting Up General Ledger:	
Accounting Setup Manager Main Page	Defining or modifying a legal entity, ledger, or accounting setup.
Calendars	Creating, modifying, or updating accounting calendars.
Chart of Accounts Mappings	Creating and changing chart of accounts mappings.
Common Stock	Creating and changing common stock data.
Concurrent Program Controls	Setting or changing the concurrent program controls that affect the performance of various General Ledger features.
Data Access Sets	Creating and changing data access sets.
Assign Definition Access Sets	Assigning definition access sets to responsibilities.
Define Definition Access Set	Creating or changing definition access sets.

User Function Name	Restrictions
Definition Access Set Search Launch	Creating and assigning definition access sets (web user interface).
Encumbrance Types	Defining or changing encumbrance types.
GL Accounts	Creating or changing accounts.
Restrictions User Function Name	
GL Enter Employees	Entering, changing, or deleting employees or contract (contingent) workers that make up the Journal Approval hierarchy.
Government Transaction Codes	Defining or changing government transaction codes.
Journal Authorization Limits	Defining or changing an employee's authorization limit for approving journal batches.
Journal Categories	Defining or changing journal categories.
Journal Sources	Defining or changing journal sources.
Ledger Sets	Defining or changing ledger sets.
Period Types	Defining or changing period types.
Secure an AutoPost Criteria Set	Securing AutoPost Criteria Sets using definition access sets.
Secure a Journal Reversal Criteria Set	Securing Journal Reversal Criteria sets using definition access sets.
Secure an AutoAllocation	Securing AutoAllocation sets using definition access sets.
Secure a Budget Formula	Securing Budget Formulas using definition access sets.

User Function Name	Restrictions
Secure a Budget Organization	Securing Budget Organizations using definition access sets.
Secure an Accounting Calendar	Securing Accounting Calendars using definition access sets.
Secure a Chart of Accounts Mapping	Securing Chart of Accounts Mappings using definition access sets.
Secure a Consolidation	Securing Consolidation definitions using definition access sets.
Secure a Consolidation Set	Securing Consolidation Definition Sets using definition access sets.
Secure an Elimination Set	Securing Elimination Sets using definition access sets.
Secure a FSG Column Set	Securing FSG Column Sets using definition access sets.
Secure a FSG Content Set	Securing FSG Content Sets using definition access sets.
Secure a FSG Report	Securing FSG Reports using definition access sets.
Secure a FSG Report Set	Securing FSG Report Sets using definition access sets.
Secure a FSG Row Order	Securing FSG Row Orders using definition access sets.
Secure a FSG Row Set	Securing FSG Row Sets using definition access sets.
Secure a MassAllocation	Securing MassAllocations using definition access sets.
Secure a MassBudget	Securing MassBudgets using definition access sets.

User Function Name	Restrictions
Secure a Rate Type	Securing Currency Rate Types using definition access sets.
Secure a Recurring Journal	Securing Recurring Journals using definition access sets.
Secure a Revaluation	Securing Revaluations using definition access sets.
Secure a Transaction Calendar	Securing Transaction Calendars using definition access sets
Submission Schedules	Creating or changing GL submission schedules.
Statistical Units of Measure	Defining or changing statistical units of measure used to enter non-monetary data in journal entries and journal batches.
Storage Parameters	Changing the storage parameters of interim tables and indexes used by General Ledger.
Summary Accounts	Defining or modifying summary accounts.
Suspense Accounts	Defining or changing suspense accounts.
Tax Options	Defining or changing the options for automatic tax calculation.
Transaction Calendars	Defining or changing transaction calendars used for average balance processing.
Maintaining General Ledger:	
Account Hierarchy Manager	Creating or changing segment values and their attributes.
Account Hierarchy Manager Super User	Creating or changing segment values and their attributes for all charts of accounts in the system.

User Function Name	Restrictions
Archive and Purge	Archiving and purging actual, translated, budget, and encumbrance account balances, and journal batches, entries, lines, and associated journal references.
Open and Close Periods	Opening and closing accounting periods.
Year-End Carry Forward	Carrying forward year-end encumbrances, encumbered budgets, and funds available into the following year.
Mass Maintenance Workbench:	
Mass Maintenance Workbench	Accessing and using Mass Maintenance Workbench features.
Mass Maintenance Workbench: Purge	Purging Move/Merge tables.
Mass Maintenance Workbench: Reverse	Reversing a Move/Merge operation.
Mass Maintenance Workbench: Submit	Submitting a Move/Merge or Mass Creation operation.
Mass Maintenance Workbench: Pre-Validate	Prevalidating Move/Merge accounts.

Related Topics

Overview of Function Security, *Oracle Applications System Administrator's Guide*

How Function Security Works, *Oracle Applications System Administrator's Guide*

Implementing Function Security, *Oracle Applications System Administrator's Guide*

Defining a New Menu Structure, *Oracle Applications System Administrator's Guide*

Business Events

Business Event System Seed Data for Oracle General Ledger

The Oracle Workflow Business Event System, introduced in Release 2.6, allows products to seed business events and event subscriptions. The seeded business events in General Ledger are listed below.

You can define subscriptions to seeded events that specify the processing to perform when these events occur.

See Also: To View and Maintain Event Subscriptions, *Oracle Workflow Developer's Guide*.

Seeded Business Events

The following are General Ledger seeded business events:

- account disabled
- period opened
- period closed
- period re-opened
- journal import started
- journal import completed
- posting completed
- accounting setup completed
- reporting currency deleted
- secondary ledger deleted

- ledger balancing segment value removed
- legal entity balancing segment removed
- legal entity removed from accounting setup

Account Disabled

A General Ledger account is disabled in the GL Accounts window or by the Inherit Segment Value Attributes program.

- Internal Name: oracle.apps.gl.Maintenance.account.disable
- Generate Function: None
- Product Name: General Ledger
- Product Short Name: GL

Period Opened

A period is opened for the first time.

- Internal Name: oracle.apps.gl.CloseProcess.period.open
- Generate Function: None
- Product Name: General Ledger
- Product Short Name: GL

Period Closed

A period is closed.

- Internal Name: oracle.apps.gl.CloseProcess.period.close
- Generate Function: None
- Product Name: General Ledger
- Product Short Name: GL

Period Re-Opened

A period is re-opened after it was previously closed.

- Internal Name: oracle.apps.gl.CloseProcess.period.reopen
- Generate Function: None
- Product Name: General Ledger
- Product Short Name: GL

Journal Import Started

The journal import process has been initiated.

- Internal Name: oracle.apps.gl.Journals.journal.startImport
- Generate Function: None
- Product Name: General Ledger
- Product Short Name: GL

Journal Import Completed

The journal import process has completed.

- Internal Name: oracle.apps.gl.Journals.journal.completeImport
- Generate Function: None
- Product Name: General Ledger
- Product Short Name: GL

Posting Completed

Posting has completed.

- Internal Name: oracle.apps.gl.Journals.journal.post
- Generate Function: None
- Product Name: General Ledger
- Product Short Name: GL

Accounting Setup Completed

Accounting setup is marked complete in Accounting Setup Manager.

- Internal Name: oracle.apps.gl.Setup.AccountingSetup.complete
- Generate Function: None
- Product Name: General Ledger
- Product Short Name: GL

Reporting Currency Deleted

REPORTING CURRENCY is deleted from accounting setup.

- Internal Name: oracle.apps.gl.Setup.ReportingLedger.delete
- Generate Function: None
- Product Name: General Ledger
- Product Short Name: GL

Secondary Ledger Deleted

Secondary Ledger is deleted from accounting setup.

- Internal Name: oracle.apps.gl.Setup.SecondaryLedger.delete
- Generate Function: None
- Product Name: General Ledger
- Product Short Name: GL

Ledger Balancing Segment Value Removed

Balancing segment value is removed from ledger.

- Internal Name: oracle.apps.gl.Setup.Ledger.BalancingSegmentValueRemove
- Generate Function: None
- Product Name: General Ledger
- Product Short Name: GL

Legal Entity Balancing Segment Removed

Balancing segment value is removed from legal entity.

- Internal Name: oracle.apps.gl.Setup.LegalEntity.BalancingSegmentValueRemove
- Generate Function: None
- Product Name: General Ledger
- Product Short Name: GL

Legal Entity Removed from Accounting Setup

Legal entity is removed from accounting setup.

- Internal Name: oracle.apps.gl.Setup.Ledger.LegalEntityRemove
- Generate Function: None
- Product Name: General Ledger
- Product Short Name: GL

Index

A

Account Hierarchy Editor

- planning parent values and rollup groups, 1-183

Account Hierarchy Editor Manager

- edit menu, 1-76

account hierarchy manager

- overview, 1-66

- security, 1-68

Account Hierarchy Manager

- adding/changing account hierarchies, 1-79

- adding or changing child values, 1-84

- adding or changing parent values, 1-81

- adding or changing rollup groups, 1-86

- Chart of Account Segments window, 1-71

- closing, 1-89

- displaying multiple hierarchies, 1-75

- displaying segment value details, 1-75

- exporting from, 1-88

- file menu, 1-76

- interface, 1-70

- menu, 1-76

- merging ranges, 1-83

- mouse activated menus, 1-77

 - attributes window, 1-78

 - hierarchy window, 1-78

 - values list window, 1-77

- overview, 1-66

- parent levels concept, 1-66

- planning your hierarchies, 1-68

- Query Values window, 1-71

- starting, 1-69

- toolbar, 1-75

- using, 1-66

- Value Details window, 1-74

- Value List window, 1-73

- view menu, 1-77

- window menu, 1-77

accounting flexfield

- future use, 1-43

accounting flexfields

- child values, 1-56

- defining account structure, 1-44

- defining balancing segments, 1-47

- defining cost center segments, 1-47

- defining dependent segments, 1-47

- defining segment value qualifiers, 1-52

- designing, 1-34

- designing account segments, 1-39

- determining your account needs, 1-37

- major features, 1-35

- natural account segment, 1-46

- parent values, 1-56

- qualifiers, 1-46

- rollup groups, 1-57

- value hierarchies, 1-55, 1-57

accounting flexfield segment

- future use, 1-43

accounts

- defining, 1-59

- defining statistical accounts, 1-192

- defining summary accounts, 1-186

- defining suspense accounts, 1-168

- disabling, 1-61

- populating attributes, 1-64
- segment value inheritance, 1-61
- using Account Hierarchy Manager, 1-66
- account structure
 - defining, 1-44
 - defining segment value qualifiers, 1-48
- approval hierarchy
 - creating, 1-139
- authorization limits
 - defining, 1-139
- average balance processing
 - adjusting periods ignored, 1-107
 - average consolidation journal source, 1-157
 - defining transaction calendars, 1-108
 - effective date rule for journal sources, 1-161
 - enabling for a ledger, 1-110
 - posting not allowed for net income account, 1-60
- average balance processing setup
 - assigning transaction calendars, 1-21
 - defining a net income account, 1-21
 - defining transaction calendars, 1-108
 - enabling average balance processing, 1-21
 - specifying effective date rules for journal sources, 1-11, 1-20

B

- balancing segments, 1-47
- budgetary control
 - setting summary account options, 1-190
 - using transaction codes with, 1-170

C

- calendars
 - adding periods, 1-104
 - assigning to a ledger, 1-110
 - changing, 1-107
 - defining, 1-103
- Calendar window, 1-103, 1-107
- chart of accounts
 - defining, 1-28
 - defining descriptive flexfields, 1-33
- closing Account Hierarchy Manager, 1-89
- Code combinations, 1-210
- currencies
 - assigning a functional currency, 1-110

D

- descriptive flexfields
 - defining in General Ledger, 1-33
 - Journals - Captured Information, 1-33
- document sequences
 - assigning, 1-196
 - assigning by entry method, 1-198
 - assigning by ledger, 1-198

E

- effective date rule, 1-161
- encumbrances
 - opening an encumbrance year, 1-218
- entering
 - Italic
 - index entries for specific object to enter, 1-139
- Enter Person window, 1-139
- exporting from Account Hierarchy Manager, 1-88

F

- financial schedules
 - defining, 1-212
- Find Key Flexfield Segment window, 1-210
- freezing subledger journals, 1-156
- function security in General Ledger, 6-1

G

- general ledger
 - setup, 1-156
- General Ledger
 - Account Hierarchy Manager, 1-66
- General Ledger Command Center
 - data access security, 2-2
 - loading data, 2-5
 - profile options, 2-3
 - setting up, 2-2
 - setup and configuration, 2-2
- General Ledger performance
 - improving, 5-1
- GL Accounts window, 1-59, 1-211

I

implementation considerations, 1-1
improving performance, 5-1
installation
 planning, 1-28
intercompany segment, 1-32

J

journal approval
 creating an approval hierarchy, 1-139
 defining authorization limits, 1-139
 enabling in a ledger, 1-138
 journal sources, 1-139
 notification reassignment approval list, 1-140
 setting up, 1-137
Journal Authorization Limits window, 1-139
journal categories
 defining, 1-162
Journal Categories window, 1-162
journal entries
 defining categories, 1-162
 defining sources, 1-156
journal import
 defining sources, 1-156
Journals - Captured Information descriptive
flexfield, 1-33
journal sources
 average consolidation, 1-157
 defining, 1-156
 effective date rule used for average balance
 processing, 1-161
 freezing, 1-156
 requiring journal approval, 1-139
Journal Sources window, 1-156

K

key flexfields
 accounting flexfields, 1-34

L

ledger
 defining, 1-110
 enabling average balance processing, 1-110
ledger window, 1-110

M

Maintain Authorized Users for Journal Approval
Reassignment program, 1-140
Maintain Summary Templates program, 5-2
managing system resources
 running the Maintain Summary Templates
 program, 5-2
 running the Optimizer program, 5-2
 storage parameters for interim tables, 1-213

N

notification reassignment approval list
 restricting, 1-140

O

Open and Close Periods window, 1-214, 1-218
Optimizer program, 5-2
overview
 segment value inheritance, 1-61

P

parent-child relationships
 creating, 1-57
parent levels concept
 account hierarchy manager, 1-66
parent values, 1-55
 planning and defining, 1-183
performance
 improving for General Ledger, 5-1
periods
 adding to a calendar, 1-104
 defining future-enterable periods, 1-110
 defining period types, 1-101
 opening and closing, 1-214
 reopening, 1-214
period status
 closed, 1-214
 future-entry, 1-215
 never opened, 1-214
 open, 1-214
 permanently closed, 1-214
Period Types window, 1-101
programs
 Maintain Authorized Users for Journal
 Approval Reassignment, 1-140
 Maintain Summary Templates, 5-2

- Optimizer, 5-2
- project tracking
 - maintaining project balances, 1-91
 - reporting on projects in GL, 1-92
 - setting up in GL, 1-89
 - setting up project budgets, 1-90

Q

- qualifiers
 - accounting flexfields, 1-46

R

- Reconciliation for account segment values
 - enabling, 1-210
- Reconciliation for code combinations
 - enabling, 1-211
- rollup groups, 1-57
 - accounting flexfields, 1-55
 - creating, 1-57
 - planning and defining, 1-183

S

- security rules, 1-32
- Segment Qualifiers window, 1-211
- segment value inheritance, 1-61
- segment value qualifiers, 1-52
- Segment Values window, 1-210
- Sequence Assignments window, 1-196
- setting up, 1-110
 - defining accounts, 1-59
 - defining calendars, 1-102
 - defining descriptive flexfields, 1-33
 - defining financial schedules, 1-212
 - defining project segments, 1-89
 - defining summary accounts, 1-186
 - defining transaction codes, 1-176
 - defining your chart of accounts, 1-28
 - General Ledger setup flowchart, 1-5
 - journal approval, 1-137
 - journal categories, 1-162
 - journal sources, 1-156
 - opening and closing accounting periods, 1-214
 - period types, 1-101
 - project tracking in GL, 1-89
 - statistical accounts, 1-192

- suspense accounts, 1-168
- transaction calendars, 1-108
- transaction codes, 1-175
- setup, 1-1
 - related products, 1-4
- setup checklist, 1-7
- setup steps, 1-16
- STAT
 - (see: Statistics and Currencies), 1-194
- Statistical Units of Measure window, 1-193
- statistics
 - defining statistical accounts, 1-192
 - defining units of measure, 1-193
 - reporting on, 1-193
- storage parameters
 - setting, 1-213
- Storage Parameters window, 1-213
- summary accounts
 - defining, 1-186
 - determining your needs, 1-178
 - entering templates, 1-188
 - maintaining, 1-189
 - planning, 1-177
 - planning parent values and rollup groups, 1-183
 - planning summary account templates, 1-184
 - planning the structure, 1-179
 - setting budgetary control options, 1-190
- Summary Accounts window, 1-186, 1-188, 1-190
- suspense account
 - defining, 1-168
- Suspense Accounts window, 1-168

T

- tax
 - calculation rules, 1-206
 - formulas and rounding, 1-206
 - journal-level calculation, 1-209
 - line-level calculation, 1-207
 - setting up automatic tax, 1-203
- transaction calendars
 - business day defaults, 1-109
 - defining, 1-108
- transaction codes
 - changing, 1-173
 - defining, 1-176

- entering, 1-171
- overview, 1-169
- reversing a transaction with, 1-173
- setting up, 1-175
- using budgetary control with, 1-170
- when to use, 1-170

Transaction Codes window, 1-176

U

units of measure

- defining, 1-193

V

values

- child, 1-55
- detail, 1-55
- parent, 1-55
- summary, 1-55

value sets

- parent values, 1-55
- value hierarchies, 1-57

W

Windows

- GL Accounts window, 1-211
- Segment Qualifiers window, 1-211
- Segment Values window, 1-210

workflow

- business event system, 7-1

