

**Oracle® Communications
EAGLE**

ENUM User's Guide

Release 46.4

E79820 Revision 1

December 2016

Oracle Communications EAGLE ENUM User's Guide, Release 46.4

Copyright © 1993, 2016, Oracle and/or its affiliates. All rights reserved.

This software and related documentation are provided under a license agreement containing restrictions on use and disclosure and are protected by intellectual property laws. Except as expressly permitted in your license agreement or allowed by law, you may not use, copy, reproduce, translate, broadcast, modify, license, transmit, distribute, exhibit, perform, publish, or display any part, in any form, or by any means. Reverse engineering, disassembly, or decompilation of this software, unless required by law for interoperability, is prohibited.

The information contained herein is subject to change without notice and is not warranted to be error-free. If you find any errors, please report them to us in writing.

If this is software or related documentation that is delivered to the U.S. Government or anyone licensing it on behalf of the U.S. Government, then the following notice is applicable:

U.S. GOVERNMENT END USERS: Oracle programs, including any operating system, integrated software, any programs installed on the hardware, and/or documentation, delivered to U.S. Government end users are "commercial computer software" pursuant to the applicable Federal Acquisition Regulation and agency-specific supplemental regulations. As such, use, duplication, disclosure, modification, and adaptation of the programs, including any operating system, integrated software, any programs installed on the hardware, and/or documentation, shall be subject to license terms and license restrictions applicable to the programs. No other rights are granted to the U.S. Government.

This software or hardware is developed for general use in a variety of information management applications. It is not developed or intended for use in any inherently dangerous applications, including applications that may create a risk of personal injury. If you use this software or hardware in dangerous applications, then you shall be responsible to take all appropriate fail-safe, backup, redundancy, and other measures to ensure its safe use. Oracle Corporation and its affiliates disclaim any liability for any damages caused by use of this software or hardware in dangerous applications.

Oracle and Java are registered trademarks of Oracle and/or its affiliates. Other names may be trademarks of their respective owners.

Intel and Intel Xeon are trademarks or registered trademarks of Intel Corporation. All SPARC trademarks are used under license and are trademarks or registered trademarks of SPARC International, Inc. AMD, Opteron, the AMD logo, and the AMD Opteron logo are trademarks or registered trademarks of Advanced Micro Devices. UNIX is a registered trademark of The Open Group.

This software or hardware and documentation may provide access to or information about content, products, and services from third parties. Oracle Corporation and its affiliates are not responsible for and expressly disclaim all warranties of any kind with respect to third-party content, products, and services unless otherwise set forth in an applicable agreement between you and Oracle. Oracle Corporation and its affiliates will not be responsible for any loss, costs, or damages incurred due to your access to or use of third-party content, products, or services, except as set forth in an applicable agreement between you and Oracle.

Table of Contents

Chapter 1: Introduction.....	8
Overview.....	9
Scope and Audience.....	9
Documentation Admonishments.....	9
Manual Organization.....	10
My Oracle Support (MOS).....	10
Emergency Response.....	11
Related Specifications.....	11
Customer Training.....	11
Locate Product Documentation on the Oracle Help Center Site.....	12
Chapter 2: Feature Description.....	13
Introduction.....	14
Redundancy/Failover.....	16
ENUM Connection States.....	17
Congestion Manager.....	18
Flow Control.....	18
ENUM DNS Interface.....	19
Header Section Format.....	20
Question Section Format.....	22
Resource Record Format.....	22
ENUM Query Format.....	26
ENUM Response Format.....	27
ENUM Application.....	31
ENUM Query Screening.....	31
ENUM Query Validation.....	32
ENUM Response.....	33
ENUM Database.....	35
ENUM Profile Selection Table (ENUMPRID).....	35
ENUM DN Block Profile Table (ENUMDNBK).....	36
ENUM Profile Table (ENUMPROF).....	38
ENUM Options Table (ENUMOPTS).....	40
ENUM Query Processing for MNP.....	40
MNP RxDDB Lookup.....	44

ENUM Feature Limitations.....	45
Hardware Requirements.....	46
Chapter 3: Commands.....	51
Introduction.....	52
EAGLE Commands Added to Support ENUM.....	52
EAGLE Commands Modified to Support ENUM.....	55
EAGLE Pass-Through Commands.....	56
Chapter 4: Feature Configuration.....	57
Introduction.....	58
ENUM Configuration.....	58
Chapter 5: Measurements.....	60
ENUM Measurements.....	61
Chapter 6: Maintenance.....	64
Alarms.....	65
UIMs.....	65
Thermal Management Parameters.....	66
Glossary.....	68

List of Figures

Figure 1: ENUM Architecture on EAGLE.....15

Figure 2: ENUM Tier Record Resolution.....16

Figure 3: Network Redundancy for ENUM Cards.....17

Figure 4: ENUM Message Flow for MNP.....42

Figure 5: ENUM Message Flow within EAGLE.....43

Figure 6: ENUM Default Profile Response.....44

Figure 7: MNP RxDDB Database Lookup.....45

Figure 8: SLIC ENUM Card - Ethernet Interface Connections and Status LEDs.....48

Figure 9: SLIC Faceplate Status LEDs.....49

List of Tables

Table 1: Admonishments.....	9
Table 2: ENUM Connection States.....	18
Table 3: ENUM Congestion Thresholds.....	18
Table 4: DNS Header Section Format.....	20
Table 5: DNS Question Section Format.....	22
Table 6: DNS Resource Record Format.....	23
Table 7: NAPTR Resource Record Format.....	24
Table 8: ENUM Query Section Format - Header Section	26
Table 9: ENUM Query Section Format - Question Section	27
Table 10: ENUM Response Format - Header Section.....	27
Table 11: ENUM Response Format - Question Section.....	28
Table 12: ENUM Response Format - Answer Section.....	28
Table 13: ENUM Response Format - Authority Section.....	29
Table 14: ENUM Error Response Codes (RCODEs).....	30
Table 15: ENUM Error Response - Header Section.....	30
Table 16: ENUMACL Table.....	32
Table 17: ENUMACL Table Example Entries.....	32
Table 18: ENUM Query Validation Errors.....	32
Table 19: Pre-defined Fields for NAPTR Response.....	33
Table 20: ENUM NAPTR RR Regular Expression Format.....	34
Table 21: ENUM NS Response Pre-defined Fields.....	34
Table 22: ENUM CNAME Response Pre-defined Fields.....	35

Table 23: ENUMPRID Table Parameters.....	36
Table 24: ENUMPRID Table Example Entries.....	36
Table 25: ENUMDNBK Table Parameters.....	37
Table 26: ENUMDNBK Table Example Entries.....	37
Table 27: ENUMPROF Table Parameters.....	38
Table 28: ENUMPROF Table Example Entries.....	39
Table 29: ENUMOPTS Table Parameters.....	40
Table 30: E5-SM8G-B Faceplate IP Interface/Logical Link Status LED Operation for Port A.....	47
Table 31: E5-SM8G-B Faceplate IP Interface/Logical Link Status LED Operation for Port B.....	47
Table 32: SLIC Faceplate IP Interface/Logical Link Status LED Operation for Port A (Represented by LED 1).....	49
Table 33: SLIC Faceplate IP Interface/Logical Link Status LED Operation for Port B (Represented by LED 3).....	50
Table 34: EAGLE Commands Modified to Support ENUM.....	55
Table 35: ENUM System Level Measurements Pegs.....	61
Table 36: ENUM Card Level Measurements Pegs.....	62
Table 37: ENUM Entity Level Measurements Pegs.....	62
Table 38: ENUM ACL Level Measurements Pegs.....	63
Table 39: Unsolicited Alarm Messages.....	65
Table 40: Unsolicited Information Messages.....	66
Table 41: Thermal Management Parameters.....	67

Chapter 1

Introduction

Topics:

- *Overview.....9*
- *Scope and Audience.....9*
- *Documentation Admonishments.....9*
- *Manual Organization.....10*
- *My Oracle Support (MOS).....10*
- *Emergency Response.....11*
- *Related Specifications.....11*
- *Customer Training.....11*
- *Locate Product Documentation on the Oracle Help Center Site.....12*

This chapter provides a brief description of the ENUM Mobile Number Portability and Tier One Address Resolution (ENUM) feature of the Oracle Communications EAGLE. The chapter also includes the scope, audience, and organization of the manual; how to find related publications; and how to contact Oracle for assistance.

Overview

This manual provides feature descriptions, along with commands, maintenance, measurements, and configuration details associated with the ENUM Mobile Number Portability and Tier One Address Resolution (ENUM) feature of the Oracle Communications EAGLE. The ENUM feature adds an E.164 Number Mapping (ENUM) interface to allow ENUM Number Portability Query messages to be received by an EAGLE ENUM card, processed by the database (RxDB, ENUM), and then a Tier 1 ENUM Response message pointing to a carrier Tier 2 server returned to the requestor. The ENUMHC and ENUM64 GPLs support the ENUM protocol over UDP; these GPLs run on the E5-SM8G-B or SLIC card.





Scope and Audience

This manual is intended for anyone responsible for installing, maintaining, and using the Oracle Communications EAGLE ENUM Mobile Number Portability and Tier One Address Resolution feature. Users of this manual must have a working knowledge of telecommunications and network installations.

Documentation Admonishments

Admonishments are icons and text throughout this manual that alert the reader to assure personal safety, to minimize possible service interruptions, and to warn of the potential for equipment damage.

Table 1: Admonishments

Icon	Description
 DANGER	Danger: (This icon and text indicate the possibility of <i>personal injury</i> .)
 WARNING	Warning: (This icon and text indicate the possibility of <i>equipment damage</i> .)
 CAUTION	Caution: (This icon and text indicate the possibility of <i>service interruption</i> .)
 TOPPLE	Topple: (This icon and text indicate the possibility of <i>personal injury and equipment damage</i> .)

Manual Organization

This document is organized into the following chapters:

- *Introduction* contains general information about the ENUM Mobile Number Portability and Tier One Address Resolution documentation, the organization of this manual, and how to request technical assistance.
- *Feature Description* provides a functional description of the ENUM Mobile Number Portability and Tier One Address Resolution feature, including feature options, considerations, and call flows.
- *Commands* describes the commands that support the ENUM Mobile Number Portability and Tier One Address Resolution feature.
- *Feature Configuration* contains procedures to configure the ENUM Mobile Number Portability and Tier One Address Resolution feature.
- *Measurements* describes the measurements and reports available for the ENUM Mobile Number Portability and Tier One Address Resolution feature.
- *Maintenance* describes maintenance information available for the ENUM Mobile Number Portability and Tier One Address Resolution feature which may include: Oracle Communications EAGLE Application Processor (EPAP) status and alarms, hardware verification messages, system status reports and commands, code and application data loading, and alarms.

My Oracle Support (MOS)

MOS (<https://support.oracle.com>) is your initial point of contact for all product support and training needs. A representative at Customer Access Support (CAS) can assist you with MOS registration.

Call the CAS main number at 1-800-223-1711 (toll-free in the US), or call the Oracle Support hotline for your local country from the list at <http://www.oracle.com/us/support/contact/index.html>. When calling, make the selections in the sequence shown below on the Support telephone menu:

1. Select **2** for New Service Request
2. Select **3** for Hardware, Networking and Solaris Operating System Support
3. Select one of the following options:
 - For Technical issues such as creating a new Service Request (SR), Select **1**
 - For Non-technical issues such as registration or assistance with MOS, Select **2**

You will be connected to a live agent who can assist you with MOS registration and opening a support ticket.

MOS is available 24 hours a day, 7 days a week, 365 days a year.

Emergency Response

In the event of a critical service situation, emergency response is offered by the Customer Access Support (CAS) main number at 1-800-223-1711 (toll-free in the US), or by calling the Oracle Support hotline for your local country from the list at <http://www.oracle.com/us/support/contact/index.html>. The emergency response provides immediate coverage, automatic escalation, and other features to ensure that the critical situation is resolved as rapidly as possible.

A critical situation is defined as a problem with the installed equipment that severely affects service, traffic, or maintenance capabilities, and requires immediate corrective action. Critical situations affect service and/or system operation resulting in one or several of these situations:

- A total system failure that results in loss of all transaction processing capability
- Significant reduction in system capacity or traffic handling capability
- Loss of the system's ability to perform automatic system reconfiguration
- Inability to restart a processor or the system
- Corruption of system databases that requires service affecting corrective actions
- Loss of access for maintenance or recovery operations
- Loss of the system ability to provide any required critical or major trouble notification

Any other problem severely affecting service, capacity/traffic, billing, and maintenance capabilities may be defined as critical by prior discussion and agreement with Oracle.

Related Specifications

For information about additional publications related to this document, refer to the Oracle Help Center site. See [Locate Product Documentation on the Oracle Help Center Site](#) for more information on related product publications.

Customer Training

Oracle University offers training for service providers and enterprises. Visit our web site to view, and register for, Oracle Communications training:

<http://education.oracle.com/communication>

To obtain contact phone numbers for countries or regions, visit the Oracle University Education web site:

www.oracle.com/education/contacts

Locate Product Documentation on the Oracle Help Center Site

Oracle Communications customer documentation is available on the web at the Oracle Help Center (OHC) site, <http://docs.oracle.com>. You do not have to register to access these documents. Viewing these files requires Adobe Acrobat Reader, which can be downloaded at <http://www.adobe.com>.

1. Access the Oracle Help Center site at <http://docs.oracle.com>.
2. Click **Industries**.
3. Under the Oracle Communications subheading, click the **Oracle Communications documentation** link.
The Communications Documentation page appears. Most products covered by these documentation sets will appear under the headings "Network Session Delivery and Control Infrastructure" or "Platforms."
4. Click on your Product and then the Release Number.
A list of the entire documentation set for the selected product and release appears.
5. To download a file to your location, right-click the **PDF** link, select **Save target as** (or similar command based on your browser), and save to a local folder.

Chapter 2

Feature Description

Topics:

- *Introduction.....14*
- *ENUM DNS Interface.....19*
- *ENUM Application.....31*
- *ENUM Feature Limitations.....45*
- *Hardware Requirements.....46*

This chapter describes the ENUM Mobile Number Portability and Tier One Address Resolution feature.

Introduction

The ENUM Mobile Number Portability and Tier One Address Resolution (ENUM) feature of the Oracle Communications EAGLE enhances the ability of EAGLE to access the Number Portability database (RxDB) using ENUM protocol. Using the ENUM interface supported on UDP, EAGLE is able to process a destination number lookup in an IP-based addressing scheme in the Number Portability database and provide a routing solution to the originating carrier.

ENUM Architecture

Figure 1: ENUM Architecture on EAGLE shows the overall system architecture for the ENUM feature on the EAGLE.

- The ENUM application runs on the E5-SM8G-B or SLIC card loaded with the ENUMHC/ENUM64 GPL.
- The ENUM application communicates with OAMHC on EAGLE using the IMT bus.
- The ENUM card connects to the EPAP using Ethernet Port A.
- The ENUM card connects to the ENUM clients (switches or CSCF) using Ethernet Port B.

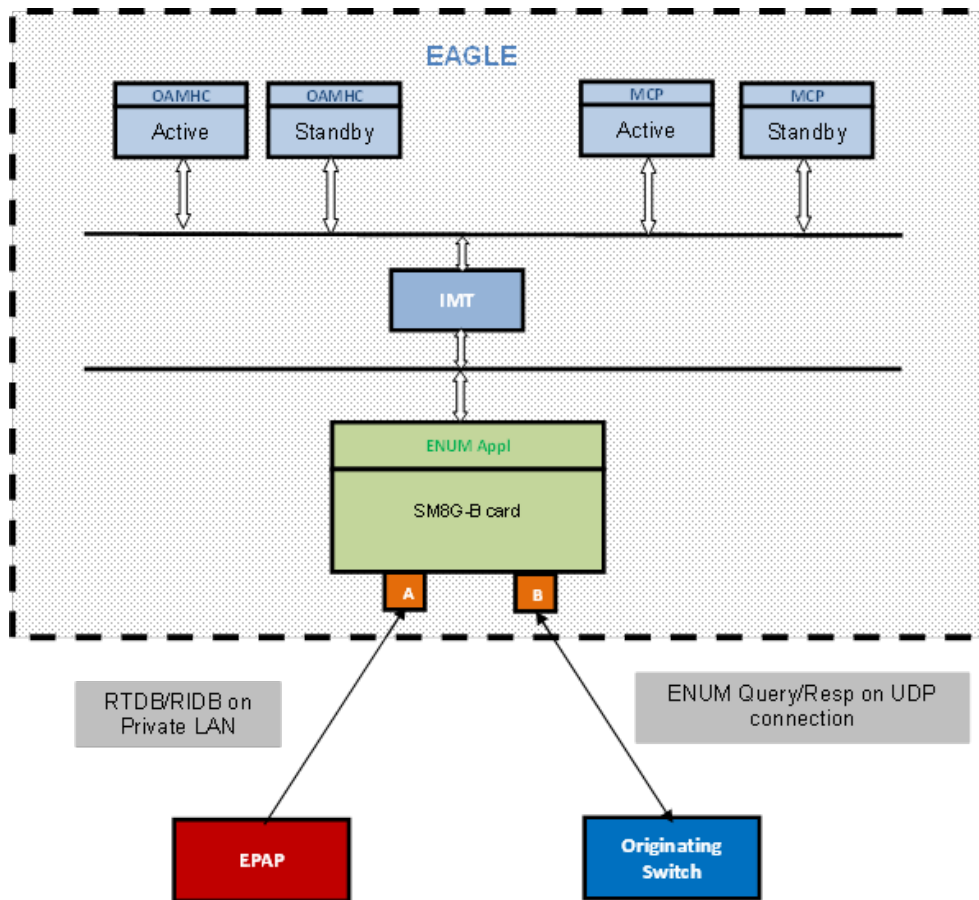

Figure 1: ENUM Architecture on EAGLE

E.164 Number Mapping (ENUM)

E.164 Number Mapping (ENUM) is a Telephone Number Mapping standard defined for mapping of traditional PSTN numbers in E.164 format to IP-based format such as URI. ENUM uses a special DNS record type to translate a telephone number into a URI that can be used in an IP network. ENUM allows Internet-based services, such as E-mail, VOIP, and Voice Mail to be located based on the telephone number. ENUM accomplishes this by placing the telephone numbers into the global Domain Name System (DNS).

An ENUM Tier resolution from a DNS perspective example is shown in [Figure 2: ENUM Tier Record Resolution](#). The ENUM data format begins with a phone number, then reverses the digits, places a "." between each number, and adds an .e164.arpa root domain that is common across both ENUM and this feature.

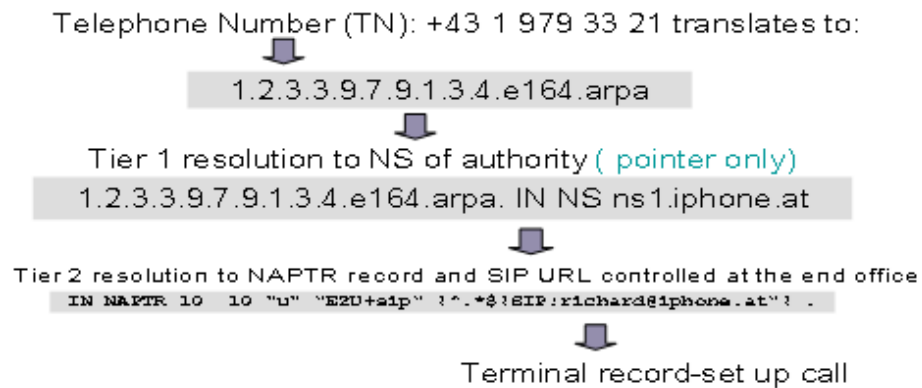

Figure 2: ENUM Tier Record Resolution

ENUM implementation is based on a tiered architecture. At Tier 0 is the RIPE NCC which maintains the e164.arpa zone. Entries in the RIPE NCC DNS server correspond to country codes or portions of country codes and point to the Tier 1 Registry that is the authoritative DNS server for that country code or portion of country code. The Tier 1 Registry maintains records that indicate the authoritative DNS server for individual E.164 numbers in the country code or portion thereof. The Tier 2 Provider for an E.164 number maintains the actual NAPTR records that contain information for specific communication services.

Redundancy/Failover

Redundancy is divided into the Signaling Network redundancy and the Private Network redundancy. [Figure 3: Network Redundancy for ENUM Cards](#) shows the network redundancy for ENUM cards on EAGLE.

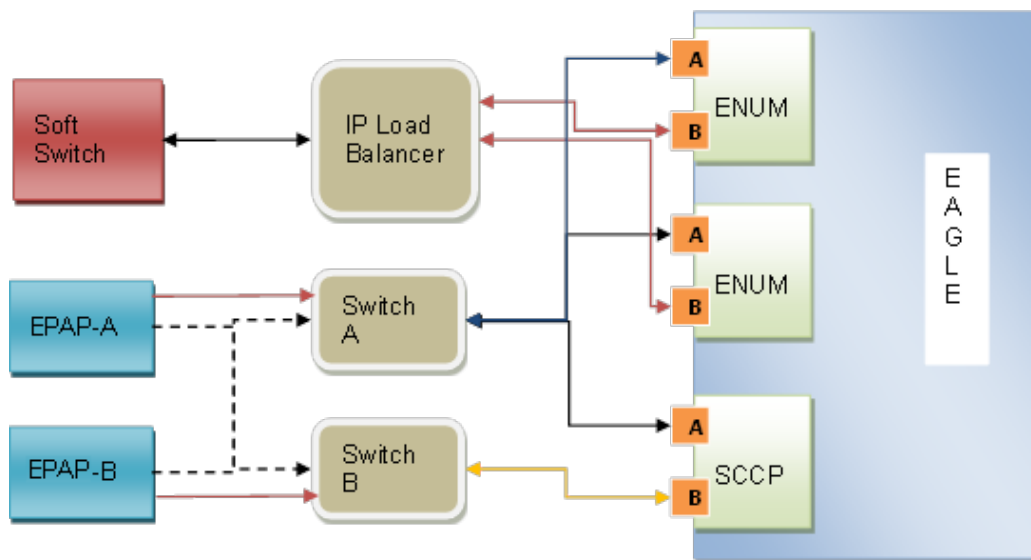

Figure 3: Network Redundancy for ENUM Cards

Signaling Network

EAGLE supports up to 16 ENUM cards. Each ENUM card has its own IP address and operates independently. EAGLE does not provide load balancing between multiple ENUM cards. Users can implement load balancing on the client side or use a third-party load balancer between the client and the ENUM server on EAGLE which tracks connection status of each ENUM card. The ENUM client or load balancer must implement a failover mechanism in the event of connection failure and ENUM application card failure.

An ENUM card discards incoming messages from the ENUM client and pegs measurements for discarded ENUM queries in these two scenarios:

- Inbound connection congestion on the ENUM card - Socket queue or Application Receive queue becoming full
- Connection failure - ENUM messages on Receive and Transmit queues discarded

Private Network

An ENUM card connects to the EPAP on a private network using Ethernet Port A. The RxDB data is downloaded to the ENUM card in same manner as Service Module cards are loaded.

However EPAP connectivity to an ENUM card and a Service Module card are different in the event of failure of Switch A. If Switch A (between EPAP A and EAGLE) or Port A on the EAGLE Service Module card fails, the Service Module card starts data download using Switch B or Port B. For the ENUM card, the connecting cable must be moved manually to the other switch, and then the ENUM card re-provisioned with the address of the other EPAP.

ENUM Connection States

The ENUM server connection is based on UDP socket and it has three states as shown in [Table 2: ENUM Connection States](#).

Table 2: ENUM Connection States

State	Description
OPEN	ENUM connection is set OPEN=YES by OAM. The ENUM server UDP socket is created and listening for incoming ENUM packets
CLOSING	ENUM connection is set OPEN=NO by OAM. Transit state to process outstanding messages before moving to Closed state. All incoming ENUM requests are rejected in this state.
CLOSED	ENUM server UDP socket is closed.

The ENUM card is not allowed to be in the In-Service (IS-NR) state unless an ENUM server connection is provisioned on the ENUM card. Initially after provisioning a new ENUM server connection, the connection is set to the CLOSED state with OPEN=NO. When OPEN is changed to YES, the ENUM application creates a new UDP socket listening for incoming ENUM Request messages and the connection is changed to the OPEN state. In the OPEN state, the ENUM card is ready to receive and process incoming ENUM traffic. When the ENUM connection is set to OPEN=NO, the connection state transitions to the CLOSING state. In the CLOSING state, new incoming ENUM Request messages are rejected; only outstanding ENUM Response messages are processed and sent back to the client before transitioning to CLOSED state. In the CLOSED state, all incoming ENUM packets are discarded.

Congestion Manager

The UDP protocol used between the ENUM client and server does not support congestion handling. The ENUM application supports congestion detection and alarming for each ENUM connection. Two congestion thresholds can be configured and are derived using the ENUM card TPS as shown in [Table 3: ENUM Congestion Thresholds](#).

Table 3: ENUM Congestion Thresholds

Congestion Threshold	Value (% of Card TPS)	Notes
Congestion Level 1	0 – 100 (Default = 40)	Raise a Minor alarm when the card TPS exceeds Congestion Threshold Level 1.
Congestion Level 2	0 – 100 (Default = 80)	Raise a Major alarm when the card TPS exceeds Congestion Threshold Level 2.

The congestion caused by TPS flow control is handled according to [Flow Control](#).

Flow Control

An ENUM card can process up to 4000 messages per second (4000 TPS). Above the 4000 TPS limit, the ENUM card:

- may discard the messages
- notify the client with an ENUM Error Response message if the ENUMOPTS option CNGNTFY = TRUE

- notify the client with an ENUM Error Response Code configured in the ENUMOPTS option CNGRCODE

The allowed values for the ENUMOPTS option CNGRCODE are 5 (ENUM_QRY_REFUSED), and 11 to 15. The default value of CNGRCODE is 5. ENUM Error Response messages due to congestion are paced at a rate of one error message per 100 discarded ENUM messages at the application level.

- peg the measurements for Total Discarded ENUM Messages and Messages Discarded due to Congestion at the application level

Any incoming message discarded due to the UDP socket receive buffer overflow are silently discarded by the network stack. For those messages, discard measurement are not pegged at the application level. This may cause the Error Response message count to not match exactly the rate of one error message per 100 incoming messages causing congestion.

ENUM DNS Interface

ENUM is a telephone number mapping system designed to locate applicable communication servers on the Internet for servicing a given telephone number using DNS queries. ENUM uses a telephone number translated into URI format that is used in a DNS lookup to retrieve a DNS record that can be used in Internet communication.

The Domain Name System (DNS) is the method by which Internet addresses in mnemonic form are converted into the equivalent numeric IP address. For example, sunc.scit.wlv.ac.uk. is converted to 134.220.4.1. To the user and application process this translation is a service provided either by the local host or from a remote host using the Internet. The DNS server (or *resolver*) may communicate with other Internet DNS servers if the DNS server cannot translate the address itself. The message formats used for exchange of queries and responses between hosts and DNS servers are defined by IETF standards (RFC 1035). Queries and responses can be transferred either by TCP or UDP; the EAGLE ENUM application supports only UDP. Both queries and responses have the same general format, containing up to five individual sections carrying information.

DNS Message Format

All communications inside of the domain protocol are carried in a single format called a message. The top level format of message is divided into five sections. Some sections are empty in certain cases. The five sections are shown below.

Header	
Question	Question for the DNS Server
Answer	Resource Records answering the question
Authority	Resource Records pointing toward an authority
Additional	Resource Records holding additional information

The Header section is always present. The Header section includes fields that specify which of the remaining sections are present, and also specify whether the message is a query or a response, a standard query, or other opcode.

The names of the sections after the Header section are derived from their use in standard queries. The Question section contains fields that describe a question to a DNS Server. These fields are a Query Type (QTYPE), a Query Class (QCLASS), and a Query Domain Name (QNAME). The last three sections are the same format: a list of concatenated Resource Records (RRs) which may be empty. The Answer section contains RRs that answer the question. The Authority section contains RRs that point toward an authoritative DNS Server; the additional records section contains RRs which relate to the query, but are not strictly answers for the question.

Header Section Format

The Header section contains the following fields:

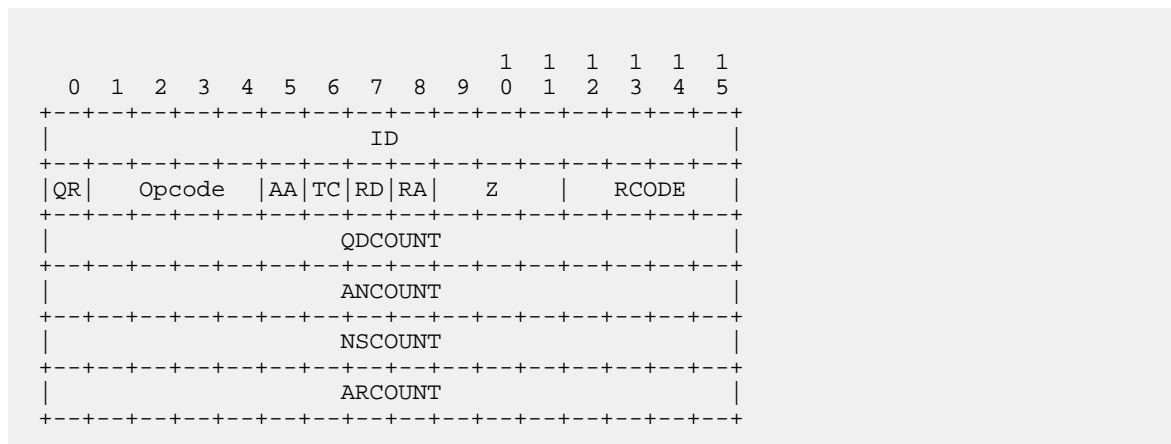

The Header section fields are described in [Table 4: DNS Header Section Format](#). The total size of the Header section format is 12 octets.

Table 4: DNS Header Section Format

Field	Type	Description
ID	Ushort	This 16-bit identifier is assigned by the program that generates any kind of query. This identifier is copied to the corresponding reply and can be used by the requester to match replies to outstanding queries.
QR	Bitfield	This 1-bit field specifies whether this message is a query (0), or a response (1).
OPCODE	Bitfield	This 4-bit field specifies the kind of query in this message. This value is set by the originator of a query and copied into the response. The values are: <ul style="list-style-type: none"> 0 - a standard query (QUERY) 1 - an inverse query (IQUERY) 2 - a server status request (STATUS)

Field	Type	Description
		Values 3 -15 are reserved for future use.
AA	Bitfield	The Authoritative Answer bit is valid in responses, and specifies that the responding DNS server is an authority for the domain name in question section.
TC	Bitfield	The Truncation bit specifies that this message was truncated due to a message length greater than the length permitted on the transmission channel.
RD	Bitfield	The Recursion Desired bit may be set in a query and is copied into the response. If the RD bit is set, the DNS server is directed to pursue the query recursively. Recursive query support is optional.
RA	Bitfield	The Recursion Available bit is set or cleared in a response, and denotes whether recursive query support is available in the DNS server.
Z	Bitfield	These bits are reserved for future use. These bits must be zero in all queries and responses.
RCODE	Bitfield	<p>The 4-bit Response Code field is set as part of responses. The values are:</p> <ul style="list-style-type: none"> 0 - No error condition 1 - Format error: The DNS server was unable to interpret the query. 2 - Server failure: The DNS server was unable to process this query due to a problem with the DNS server. 3 - Name Error: This code is only for responses from an authoritative DNS server. This code signifies that the domain name referenced in the query does not exist. 4 - Not Implemented: The DNS server does not support the requested kind of query. 5 - Refused: The DNS server refuses to perform the specified operation for policy reasons. For example, a DNS server may not wish to provide the information to the particular requester, or a DNS server may not wish to perform a particular operation (example: zone transfer) for particular data. <p>Values 6-15 are reserved for future use.</p>
QDCOUNT	Ushort	This field is an unsigned 16-bit integer specifying the number of entries in the Question section.
ANCOUNT	Ushort	This field is an unsigned 16-bit integer specifying the number of resource records in the Answer section.
NSCOUNT	Ushort	This field is an unsigned 16-bit integer specifying the number of DNS server resource records in the Authority Records (Name Server) section.

field in the header - ANCOUNT, NSCOUNT, ARCOUNT. A Resource Record (RR) has the following format:

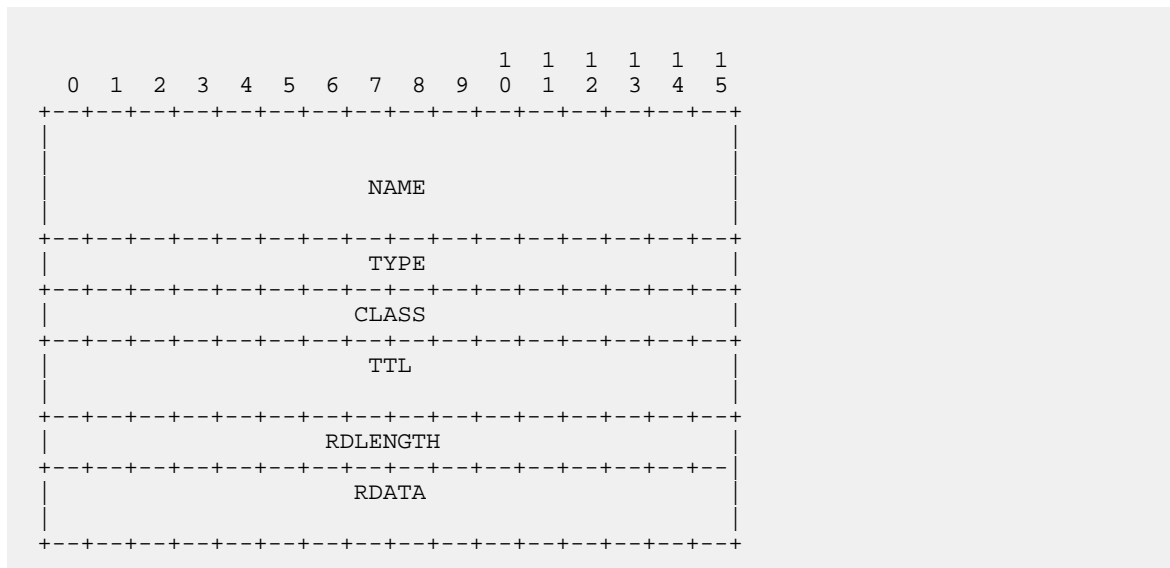

The Resource Record fields are described in [Table 6: DNS Resource Record Format](#).

Table 6: DNS Resource Record Format

Field	Type	Description
NAME	Char[]	This field is a domain name to which this resource record pertains.
TYPE	Ushort	This 2-octet field contains one of the Resource Record type codes. This field specifies the meaning of the data in the RDATA field.
CLASS	Ushort	This 2-octet field specifies the class of the data in the RDATA field.
TTL	Ulong	This field is a 32-bit unsigned integer that specifies the time interval in seconds that the Resource Record may be cached before it should be discarded. Zero values are interpreted to mean that the Resource Record can be used only for the transaction in progress, and should not be cached.
RDLENGTH	Ushort	This field is a 16-bit unsigned integer that specifies the length in octets of the RDATA field.
RDATA	Uchar[]	This variable length string of octets describes the resource. The format of this information varies according to the TYPE and CLASS of the Resource Record. For example, if the TYPE = A and CLASS = IN, the RDATA field is a 4-octet ARPA Internet address.

NAPTR Resource Record Format

The DNS type code for NAPTR is 35. The packet format for the NAPTR Resource Record (RR) is:

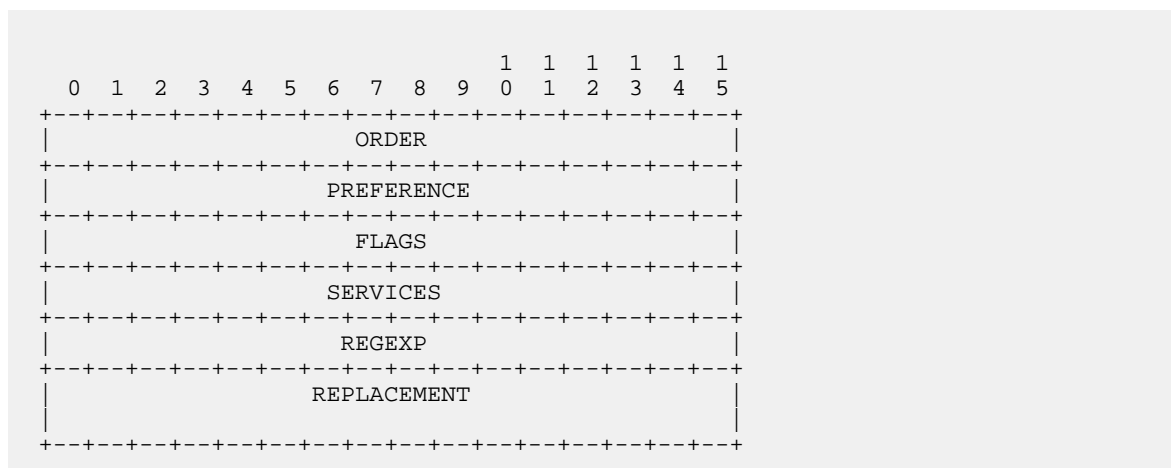

The NAPTR RR packet format fields are described in [Table 7: NAPTR Resource Record Format](#).

Table 7: NAPTR Resource Record Format

Field	Type	Description
ORDER	Ushort	This field is a 16-bit unsigned integer specifying the order in which the NAPTR records must be processed to accurately represent the ordered list of Rules. The ordering is from lowest to highest. If two records have the same order value, then they are considered to be the same rule and should be selected based on the combination of the Preference values and Services offered.
PREFERENCE	Ushort	<p>This field is a 16-bit unsigned integer that specifies the order in which NAPTR records with equal ORDER values should be processed. Low numbers are processed before high numbers.</p> <p>Although the field is identified as "Preference" in deference to DNS terminology, this field is equivalent to the Priority value in the DDDS Algorithm. This field is similar to the Preference field in an MX record, and is used to allow domain administrators to direct clients towards more capable hosts or lighter weight protocols. A client may look at records with higher preference values if the client has a valid reason (example: not capably supporting a particular protocol or service).</p> <p>The important difference between ORDER and PREFERENCE fields is that when a match is found the client must not consider records with a different ORDER but the client may process records with the same ORDER but different PREFERENCES. The only exception to this is noted in the second important note in the DDDS algorithm specification</p>

Field	Type	Description
		<p>concerning allowing clients to use more complex Service determination between steps 3 and 4 in the algorithm. PREFERENCE is used to communicate a higher quality of service to rrules that are considered the same from an authority standpoint but not from a simple load-balancing perspective.</p> <p>Note that DNS contains several load-balancing mechanisms. If load balancing among otherwise equal services is needed, then methods such as SRV records or multiple A records should be utilized to accomplish load balancing.</p>
FLAGS	Char[]	<p>This field is a character string containing flags to control aspects of the rewriting and interpretation of the fields in the record. Allowable values are single alphanumeric characters (A-Z, 0-9). Alphabetic characters can be upper case or lower case with no significance. The field can be empty. The application must specify how it is using this database to define the flags in this field, and must define which flags are terminal and which are not.</p>
SERVICES	Char[]	<p>This field is a character string that specifies the service parameters applicable to this delegation path. The application must specify the values found in this field.</p>
REGEXP	Char[]	<p>This field is a character string containing a substitution expression that is applied to the original string held by the client in order to construct the next domain name to lookup.</p> <p>As stated in the DDDS algorithm which provides the syntax of this field, the regular expressions must not be used in a cumulative fashion; they can be applied only to the original string held by the client and never to the domain name produced by a previous NAPTR rewrite.</p>
REPLACEMENT	Char[]	<p>This field is a domain name which is the next domain name to query, depending on the potential values found in the FLAGS field. The REPLACEMENT field is used when the regular expression is a simple replacement operation. Any value in this field must be a fully-qualified domain name. Name compression cannot be used for this field.</p> <p>The REPLACEMENT field and the REGEXP field together make up the Substitution Expression in the DDDS Algorithm. This field exists for reasons of historical optimization, specifically for DNS compression. The fields are mutually exclusive. If a record is returned that has values for both fields, then it is considered to be in error and either should be ignored or an error returned.</p>

NS Resource Record Format

NSDNAME is a domain name which specifies a host which should be authoritative for the specified class and domain.

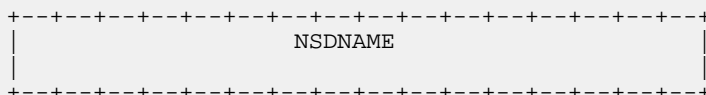

CNAME Resource Record Format

CNAME is a domain name which specifies the canonical or primary name for the owner. The owner name is an alias.

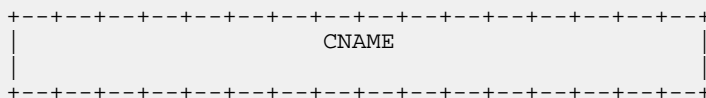

ENUM Query Format

The ENUM application (Tier 1 NAPTR) expects a DNS Query with the formats for the Header and Question sections, as shown respectively in [Table 8: ENUM Query Section Format - Header Section](#) and [Table 9: ENUM Query Section Format - Question Section](#) :

Table 8: ENUM Query Section Format - Header Section

Data Field	Description	Possible Values
ID	This 16-bit identifier is used to correlate queries and responses.	any valid 16-bit number
QR	The Query/Response field must be 0.	0 = Query
OPCODE	The OPCODE field specifies the type of query and must be 0.	0 = Standard Query
AA	The Authoritative Answer bit is ignored by the ENUM application.	0 or 1
TC	The Truncation bit must be 0.	0
RD	The Recursion Desired bit may be 0 or 1.	0 or 1
RA	The Recursion Available bit may be 0 or 1.	0 or 1
Z	Reserved; must be 0	0
RCODE	The Response Code field must be 0 in a query.	0
QDCOUNT	The Question section count must be 1.	1

Data Field	Description	Possible Values
ANCOUNT	The Answer section count must be 0.	0
NSCOUNT	The Authority Records (Name Server) section count is ignored.	0
ARCOUNT	The Additional Records section count is ignored.	0

Table 9: ENUM Query Section Format - Question Section

Data Field	Description	Possible Values
QNAME	This field is the Telephone Number to be queried in an e164.arpa format.	any valid e164.arpa format Telephone Number
QTYPE	This field is the type of Question.	<ul style="list-style-type: none"> • NAPTR (35) • NS (2) • CNAME (5)
QCLASS	This field is the class of Question.	1 (Internet)

ENUM Response Format

The ENUM application (Tier 1 NAPTR) responds with a DNS Response with the following formats for the Header, Question, Answer, and Authority sections, if no errors occurred and the carrier associated with the telephone number was found:

Table 10: ENUM Response Format - Header Section

Data Field	Description	Possible Values
ID	This identifier is used to correlate queries and responses.	The ID from the Query is placed in the ID field of the Response.
QR	The Query/Response field must be 1.	1 = Response
OPCODE	The OPCODE field specifies the type of Query and must be 0.	0 = Standard Query
AA	The Authoritative Answer bit must be 1.	1
TC	The Truncation bit must be 0.	0
RD	The Recursion Desired bit depends on the Query RD value. The RD from the Query is placed in the RD field of the Response.	0 or 1
RA	The Recursion Available bit must be 0. Recursion is not supported.	0

Data Field	Description	Possible Values
Z	Reserved; must be 0	0
RCODE	The Response Code depends on the error. (Table 14: ENUM Error Response Codes (RCODEs))	0, 1, 2, 3, 4, 5, 11 - 15
QDCOUNT	The Question section count must be 1.	1
ANCOUNT	The Answer section count can be up to 2.	0, 1, or 2
NSCOUNT	The Authority Records (Name Server) section count can be 0 or 1.	0 or 1
ARCOUNT	The Additional Records section count is ignored.	0

The Question section in the ENUM Response message reflects the Question section of the received Query.

Table 11: ENUM Response Format - Question Section

Data Field	Description	Possible Values
QNAME	This field is the Telephone Number in an e164.arpa format.	valid e164.arpa format Telephone Number of Query
QTYPE	This field is the type of Question.	<ul style="list-style-type: none"> • NAPTR (35) • NS (2) • CNAME (5)
QCLASS	This field is the class of Question.	1 (Internet)

The DNS Response from the ENUM application may include multiple Answer Response Records with the following format.

Table 12: ENUM Response Format - Answer Section

Data Field	Description	Possible Values
NAME	This field is the Telephone Number in an e164.arpa format.	valid e164.arpa format Telephone Number of Query
TYPE	This field contains the Resource Record type code.	<ul style="list-style-type: none"> • NAPTR (35) • NS (2) • CNAME (5)
CLASS	The CLASS must be 1 for Internet.	1
TTL	The Time to Live for a Resource Record to be cached in seconds is 0.	0

Data Field	Description	Possible Values
RDLENGTH	This field is the length in octets of the RDATA field.	variable
RDATA	The Resource Data field is a variable length string of octets that describes the resource.	variable
ORDER	This field specifies the order in which NAPTR records are processed. The lowest number is the highest order.	variable; 16-bit unsigned number (0 - 63535)
PREFERENCE	This field specifies the order in which NAPTR records with identical ORDER values are processed. The lowest number is the highest order.	variable; 16-bit unsigned number (9 - 63535)
FLAGS	This field controls the rewriting and interpretation of the record.	U - Terminal Rule
SERVICES	This field specifies the protocol associated with a service.	E2U+pstn:tel E2U+pstn:sip E2U+SIP
REGEXP	This field specifies the substitution expression applied to the original string.	!^.*\$!sip:\1;npdi; m=\1%40gw.example.com;user=phone! !^.*\$!sip:+1442079460148@example.com!

The Authority Section contains the name of the host on which the ENUM server (Tier 1 NAPTR) is running as authoritative for the requested query.

Table 13: ENUM Response Format - Authority Section

Data Field	Description	Possible Values
NAME	This field is the domain name to which this Resource Record pertains.	1.e164.arpa
TYPE	The Resource Record TYPE must be 2.	2 = authoritative DNS server
CLASS	The CLASS of this Query must be 1 for Internet.	1
TTL	The Time to Live for a Resource Record to be cached in seconds is 0.	0
RDLENGTH	This field is the length of the RDATA field	variable

Data Field	Description	Possible Values
RDATA	This field is the resource data.	variable
hostname	This is the hostname of the Tier 1 NAPTR ENUM Server	variable

The ENUM application uses the following response codes when responding to erroneous queries. RCODES values 6 - 10 are reserved for future use.

Table 14: ENUM Error Response Codes (RCODEs)

RCODE	Name	Error
0	No Error	Query processed successfully
1	Format Error	QR field other than 0 (a response)
1	Format Error	Could not parse Query
2	Server Failure	Database inaccessible
3	NXDomain	QNAME-domain does not match what is provisioned
4	Not Implemented	Opcode value other than 0 (not a standard DNS Query)
4	Not Implemented	TC value other than 0 (Truncated Queries are not required to be supported.)
4	Not Implemented	Z value other than 0 (Z is reserved for future use.)
4	Not Implemented	QDCOUNT value other than 1
4	Not Implemented	QTYPE value other than NAPTR (35), CNAME(5), or NS (2)
4	Not Implemented	QCLASS value other than 1
5, 11 - 15	Query Refused	Query refused due to inbound congestion

The ENUM application responds to badly-formed queries with an error response with the following format:

Table 15: ENUM Error Response - Header Section

Data Field	Description	Possible Values
ID	This identifier is used to correlate queries and responses.	The ID from the Query is placed in the ID field of the Response.
QR	The Query/Response field must be 1.	1 = Response

Data Field	Description	Possible Values
OPCODE	The OPCODE field specifies the type of Query and must be 0.	0 = Standard Query
AA	The Authoritative Answer bit must be 1.	1
TC	The Truncation bit must be 0.	0
RD	The Recursion Desired bit depends on the Query RD value. The RD from the Query is placed in the RD field of the Response.	0 or 1 This bit is ignored regardless of its value.
RA	The Recursion Available bit must be 0. Recursion is not supported.	0
Z	Reserved; must be 0	0
RCODE	The Response Code depends on the error. (Table 14: ENUM Error Response Codes (RCODEs))	0, 1, 2, 3, 4, 5, 11 - 15
QDCOUNT	The Question section count must be 1.	1
ANCOUNT	The Answer section count must be 0.	0
NSCOUNT	The Authority Records (Name Server) section count can be 0 or 1.	0 or 1
ARCOUNT	The Additional Records section count is ignored.	0

ENUM Application

The ENUM application task on each ENUM card provides the following functions:

- Receive ENUM Query messages
- Verify client IP addresses
- Validate incoming ENUM Queries
- Perform lookups in Number Portability database (RxDB) and ENUM database
- Create and send ENUM Response messages

ENUM Query Screening

The ENUM application allows ENUM Query messages to be received from only trusted ENUM clients. The ENUMACL table is used to provision the IP addresses of trusted ENUM clients. A Query message is discarded and the ENUMACLDISC measurement is pegged if the Query message is received from a client other than a trusted ENUM client stored in the ENUMACL table. The ENUMACL table has a maximum capacity of 100 IPADDR entries.

Table 16: ENUMACL Table

Field Name	Constraints	Comments
IPADDR	<ul style="list-style-type: none"> Four numbers in the range 0-255 separated by dots Mandatory 	The ENUM client IP address is allowed to query the ENUM server.

Wild Cards () in IP Addresses*

An ACL IPADDR entry of *.*.* is invalid. ACL entries which overlap with other entries with wild cards are not allowed. EAGLE allows the use of wild cards to support IP address ranges covered by an ACL entry as follows:

- xxx.xxx.xxx.*
- xxx.xxx.*.*
- xxx.*.*.*

Table 17: ENUMACL Table Example Entries

IPADDR
10.250.80.41
10.250.60.*
10.252.*.*

ENUM Query Validation

The ENUM application validates the incoming ENUM Query message to verify whether the the message conforms to the Query format specified in [ENUM Query Format](#). At a minimum, EAGLE supports validations for the error conditions shown in [Table 18: ENUM Query Validation Errors](#) to be handled during the validation of ENUM query.

Table 18: ENUM Query Validation Errors

Error Condition	Response
QR (Query /Response flag) Field in ENUM Query Header = 1	ENUM Error Response with RCODE=1 (Format Error)
OPCODE other than 0 (Not a standard DNS query)	ENUM Error Response with RCODE=4 (Not Implemented)
TC (Truncation Flag) in ENUM Query Header = 1	ENUM Error Response with RCODE=4 (Not Implemented)
TC (Truncation Flag) in ENUM query header = 0 and query packet size > 512 bytes	ENUM Error Response with RCODE=4 (Not Implemented)
Z (Reserved Field) in ENUM Query Header = 1	ENUM Error Response with RCODE=4 (Not Implemented)

Error Condition	Response
RCODE(Response Code) in ENUM Query Header = 1	ENUM Error Response with RCODE=1 (Format Error)
QDCOUNT (Question Count) in ENUM Query Header > 1	ENUM Error Response with RCODE=4 (Not Implemented)
ENUM Query Question Section QNAME field root other than e164.arpa	ENUM Error Response with RCODE=3 (Non-Existent Domain Error)
ENUM Query Question Section QTYPE field other than NAPTR (35), NS (2) or CNAME (5)	ENUM Error Response with RCODE=4 (Not Implemented)
ENUM Query Question Section QCLASS field other than 1 (Internet)	ENUM Error Response with RCODE=4 (Not Implemented)

ENUM Response

The ENUM application generates ENUM Response messages using:

- Pre-defined values for some of the fields in the Response message
- Configurable data in the ENUMPROF table
- Dynamic data resulting from the RxDDB lookup, such as Entity ID (RN)

Refer to [ENUM Profile Table \(ENUMPROF\)](#) for details on configurable fields in the ENUMPROF table to be used in building an ENUM response for NAPTR, CNAME and NS Queries.

Pre-defined Fields for NAPTR Response

[Table 19: Pre-defined Fields for NAPTR Response](#) describes the pre-defined NAPTR Resource Record (RR) fields.

Table 19: Pre-defined Fields for NAPTR Response

Data Field	Description	Pre-Defined Values
TYPE	Resource Record Type	NAPTR – 35
CLASS	Class of Query (1 for Internet)	1
TTL	Time to Live in seconds for an RR to be cached	0
ORDER	Order in which NAPTR records are processed 16-bit unsigned value (Range = 0 to 63535). Lowest number = Highest order	10
PREFERENCE	Order in which equal order NAPTR records are processed	100 - If PREF field in the ENUMPROF table = FALSE 10 – if PREF field in the ENUMPROF table = TRUE

Data Field	Description	Pre-Defined Values
FLAGS	Controls rewriting and interpretation of the record U = Terminal Rule	U
SERVICE TYPE	Supported ENUM services are: <ul style="list-style-type: none"> E2U+pstn:tel E2U+pstn:sip E2U+SIP 	Values defined for SERVICE TYPE in ENUMPROF tables are: <ul style="list-style-type: none"> PSTNTEL PSTNSIP SIP The default value is PSTNTEL.

NAPTR Resource Record Regular Expression

NAPTR Resource Record (RR) Regular expression is used to build a URI to be sent to the ENUM client in the NAPTR response. The format used for preparing regular expression in NAPTR is:

"!^.*\$!<URI>!"

The PSTNSIP URI uses percent encoding for the "@" symbol (%40). [Table 20: ENUM NAPTR RR Regular Expression Format](#) describes the format for Regular expression forming URIs for all services.

Table 20: ENUM NAPTR RR Regular Expression Format

Service	Ported	Non-Ported
PSTNSIP	<u>sip</u> :<+Called Party DN>;npdi;RN=<RN from the NPDB lookup>%40<domain name defined in ENUMPROF Table>	<u>sip</u> :<+Called Party DN>;npdi%40<domain name defined in ENUMPROF Table>
PSTNTEL	<u>Tel</u> :<+Called Party DN>;npdi;RN=<RN from the NPDB lookup>	<u>Tel</u> :<+Called Party DN>;npdi
SIP	<u>sip</u> :<+Called Party DN>@<domain name defined in ENUMPROF Table>	<u>sip</u> :<+Called Party DN>@<domain name defined in ENUMPROF Table>

Pre-defined Fields for NS Response

[Table 21: ENUM NS Response Pre-defined Fields](#) describes the NS Resource Record (RR) fields which are pre-defined.

Table 21: ENUM NS Response Pre-defined Fields

Data Field	Description	Pre-Defined Values
TYPE	Resource Record Type	2
CLASS	Class of Query (1 for Internet)	1
TTL	Time to Live in seconds for an RR to be cached	0

Pre-defined Fields for CNAME Response

[Table 22: ENUM CNAME Response Pre-defined Fields](#) describes the CNAME Resource Record (RR) which are pre-defined.

Table 22: ENUM CNAME Response Pre-defined Fields

Data Field	Description	Pre-Defined Values
TYPE	Resource Record Type	5
CLASS	Class of Query (1 for Internet)	1
TTL	Time to Live in seconds for an RR to be cached	0

ENUM Database

To generate a Response for an ENUM Query, the ENUM application performs two database lookups:

- Number Portability RxDDB lookup to find the matching Entity ID for a DN included in the incoming Query
- ENUM Database lookup to generate an ENUM response using the Entity Id as the key

The ENUM Database is composed of three tables on the EAGLE which store the data needed for generating ENUM Response based on the incoming DN in the ENUM Query.

- ENUM Profile Selection table (ENUMPRID)
- ENUM DN Block table (ENUMDNBK)
- ENUM Profile table (ENUMPROF)

The ENUMACL table which stores the IP Addresses of trusted ENUM clients is described in [ENUM Query Screening](#).

Another table used with the ENUM Mobile Number Portability and Tier One Address Resolution (ENUM) feature is the ENUM Options (ENUMOPTS) table which contains the system-wide configuration information required for the operation of the ENUM application. The ENUMOPTS table is part of the EGGLEOPTS table.

ENUM Profile Selection Table (ENUMPRID)

The ENUM Profile Selection table (ENUMPRID) provides the mapping between Entity ID and ENUM Profile Selection ID, which is used as the lookup key in the ENUM Profile table (ENUMPROF). The primary advantage of the ENUMPRID table is the flexibility provided to dynamically change the ENUM Response Resource Record format (NAPTR, NS, or CNAME) for a specific Entity ID without making provisioning changes in the Number Portability RxDDB using LSMS.

The ENUMPRID table allows a single Entity ID to be mapped to a maximum of four ENUM Profile IDs. Of the maximum of four ENUM Profile IDs, a maximum of two are for NAPTR records, one is for an NS record, and one is for a CNAME record from the ENUM Profile table (ENUMPROF). At least one Profile name must be assigned to an Entity ID entry in the ENUMPRID table. The maximum number of entries allowed in the ENUMPRID table is 1024.

Table 23: ENUMPRID Table Parameters

Name	Constraints	Comment
ENTITYID	<ul style="list-style-type: none"> digit string 1-15 digits mandatory 	This field is an individual Entity ID found from the DN or DN Block lookup in the Number Portability RxDDB.
PRN1	<ul style="list-style-type: none"> character string 10 characters 1 alphabetic character followed by 9 alphanumeric characters optional 	First Profile Name; PRN1 must be of NS type.
PRN2	<ul style="list-style-type: none"> character string 10 characters 1 alphabetic character followed by 9 alphanumeric characters optional 	Second Profile Name; PRN2 must be of CNAME type.
PRN3	<ul style="list-style-type: none"> character string 10 characters 1 alphabetic character followed by 9 alphanumeric characters optional 	Third Profile Name; PRN3 must be of NAPTR type.
PRN4	<ul style="list-style-type: none"> character string 10 characters 1 alphabetic character followed by 9 alphanumeric characters optional 	Fourth Profile Name; PRN4 must be of NAPTR type.

Table 24: ENUMPRID Table Example Entries

ENTITYID	PROFILE
1234	PROF1, PROF2
3244	PROF2

ENUM DN Block Profile Table (ENUMDNBK)

The ENUM DN Block Profile table (ENUMDNBK) provides the mapping between DN Blocks and the ENUM Profile Selection ID, which is used as the lookup key in the ENUM Profile table (ENUMPROF). The primary advantage of the ENUMDNBK table is that it provides an ENUM Profile Selection for DNs which are missing from the Individual DN table and the DN Block table in the Number Portability RxDDB. Another advantage of the ENUMDNBK table is the flexibility provided to dynamically change the ENUM Response Resource Record format (NAPTR, NS, or CNAME) for a specific DN Block without making provisioning changes in the Number Portability RxDDB using LSMS.

The ENUMDNBK table allows a single DN Block to be mapped to a maximum of four ENUM Profile IDs. Of the maximum of four ENUM Profile IDs, a maximum of two are for NAPTR records, one is for an NS record, and one is for a CNAME record from the ENUM Profile table (ENUMPROF). At least one Profile name must be assigned to a DN Block entry in the ENUMDNBK table. The maximum number of entries allowed in the ENUMDNBK table is 1024.

Table 25: ENUMDNBK Table Parameters

Name	Constraints	Comment
SDN	<ul style="list-style-type: none"> digit string 5-15 hex digits mandatory 	This field is the Starting DN in a DN Block range.
EDN	<ul style="list-style-type: none"> digit string 5-15 hex digits mandatory 	This field is the Last DN in a DN Block range. The number of EDN digits must be identical to the number of SDN digits. The EDN parameter value must be greater than the SDN parameter value.
PRN1	<ul style="list-style-type: none"> character string 10 characters 1 alphabetic character followed by 9 alphanumeric characters optional 	First Profile Name; PRN1 must be of NS type.
PRN2	<ul style="list-style-type: none"> character string 10 characters 1 alphabetic character followed by 9 alphanumeric characters optional 	Second Profile Name; PRN2 must be of CNAME type.
PRN3	<ul style="list-style-type: none"> character string 10 characters 1 alphabetic character followed by 9 alphanumeric characters optional 	Third Profile Name; PRN3 must be of NAPTR type.
PRN4	<ul style="list-style-type: none"> character string 10 characters 1 alphabetic character followed by 9 alphanumeric characters optional 	Fourth Profile Name; PRN4 must be of NAPTR type.

Table 26: ENUMDNBK Table Example Entries

SDN	EDN	PROFILE
9194841000	9194841999	PROF1, PROF2

SDN	EDN	PROFILE
7733548000	7733548999	PROF1

ENUM Profile Table (ENUMPROF)

The ENUM Profile table (ENUMPROF) contains the data needed to generate an ENUM Response for three supported Resource Record formats: NAPTR, NS and CNAME. The Profile ID selected from the Profile Selection table (ENUMPRID) lookup is used as the key to find the matching entry for the ENUM Response. The maximum allowed ENUM Profile Name (PRN) entries in the ENUMPROF table is 1024.

Table 27: ENUMPROF Table Parameters

	Constraints	Comment
PRN	<ul style="list-style-type: none"> character string 10 characters 1 alphabetic character followed by 9 alphanumeric characters mandatory 	<p>Profile Name</p> <p>The Profile Name provides the key for Profile lookup in the ENUMPROF Table.</p>
RTYPE	<ul style="list-style-type: none"> character string valid Response Type value: NAPTR [default], NS, CNAME optional 	<p>Response Type</p> <p>The Response Type determines the type of Response (NAPTR, NS, or CNAME) to send to the ENUM client.</p>
PREF	<ul style="list-style-type: none"> Boolean valid value: YES, NO [default] optional 	<p>Preferred Response</p> <p>Because the ENUM application allows only two NAPTR Resource Records in a single ENUM Response, the Preferred Response (PREF) parameter determines the values for the Order and Preference fields to be encoded for each NAPTR Resource Record. The value of this field does not apply if only one NAPTR Resource Record is in a single ENUM Response. The PREF parameter is valid for only the NAPTR Response Type.</p>
SPARM	<ul style="list-style-type: none"> character string valid values: PSTNTEL [default], PSTNSIP, SIP optional 	<p>Service Parameter (Service Type)</p> <p>The ENUM application supports only three ENUM Services: E2U+pstn:tel, E2U+pstn:sip, E2U+SIP. The SPARM parameter is valid for only the NAPTR Response Type.</p>
RRDOMAIN	<ul style="list-style-type: none"> character string valid values: 0-9 A-Z - . 	<p>Domain Name in Regular Expression</p>

	Constraints	Comment
	<ul style="list-style-type: none"> Default value is no character (<i>blank</i>) 64 characters maximum optional, except with RTYPE=NAPTR and SPARM=PSTNSIP/SIP when this parameter is mandatory 	The Domain Name in Regular Expression is the domain name used in SIP URI for both ported and non-porting numbers. The RRDOMAIN parameter is valid for only the NAPTR Response Type.
RPDOMAIN	<ul style="list-style-type: none"> character string valid values: 0-9 A-Z - . Default value is no character (<i>blank</i>) 64 characters maximum optional, except with RTYPE=NS and RTYPE=CNAME when this parameter is mandatory 	Replacement Domain Name This field is used for: <ul style="list-style-type: none"> Replacement domain name in NAPTR record Domain name of the DNS server in the NS record Canonical Name of domain server in the CNAME records

Table 28: ENUMPROF Table Example Entries

PRN	RTYPE	PREF	SPARM	RRDOMAIN	RPDOMAIN
Default	NS	NO			Gw.ns1example.com
PROF1	NAPTR	NO	PSTNTEL		
PROF2	NAPTR	YES	PSTNSIP	Gw3.nptrexample.com	
PROF3	CNAME	NO			Gw4.cnexample.com
PROF4	NS	NO			Gw4.nsexample.com
PROF5	NAPTR	YES	SIP	Gw3.nptrexample.com	

Default Profile

Upon start-up, the ENUM application initializes the first entry in the ENUM Profile table (ENUMPROF) as a default profile with these values:

- Profile Name (PRN) = default
- Response Type (RTYPE) = NAPTR
- Service Parameter (SPARM) = PSTNTEL

These provisioning rules apply to the ENUM default profile:

- Default profile cannot be deleted.
- Response Type (RTYPE) can be changed only for the default profile and no other profiles.
- Response Type (RTYPE) = CNAME is invalid for the default profile.
- Changing Response Type (RTYPE) = NS to Response Type (RTYPE) = NAPTR requires that the SPARM parameter must remain set to the default value of PSTNTEL.

- Changing Response Type (RTYPE) = NAPTR to Response Type (RTYPE) = NS requires that the Replacement Domain (RPDOMAIN) be provisioned, and the RRDOMAIN, PREF and SPARM parameters must be set to blank values.

ENUM Options Table (ENUMOPTS)

The ENUM Options table (ENUMOPTS) contains the system-wide configuration information required for the operation of the ENUM application. The ENUMOPTS table is part of the EGLEOPTS table.

Table 29: ENUMOPTS Table Parameters

Name	Constraints	Comment
MAXDNDIGS	<ul style="list-style-type: none"> • integer • range: 5 - 15 • default value: 15 	<p>Maximum Number of Digits from an Incoming ENUM Query</p> <p>If the incoming ENUM Query has a DN with the number of digits exceeding MAXDNDIGS, then only the first MAXDNDIGS digits will be used for lookup in the RxDB DN and DN Block tables.</p>
CONGLVL1	<ul style="list-style-type: none"> • integer • range: 1 - 99 • default value: 40 	ENUM Card Congestion Threshold Level 1
CONGLVL2	<ul style="list-style-type: none"> • integer • range: 2 - 100 • default value: 80 	ENUM Card Congestion Threshold Level 2
CNGNTFY	<ul style="list-style-type: none"> • Boolean • range: YES, NO • default value: NO 	Congestion Notification Flag
CNGRCODE	<ul style="list-style-type: none"> • integer • range: 5, 11 - 15 • default value: NO 	<p>RCODE Values in ENUM Error Response</p> <p>The RCODEs are sent due to congestion on the ENUM card.</p> <ul style="list-style-type: none"> • 5 = ENUM_QRY_REFUSED • 11 - 15 = USER CONFIGURABLE

ENUM Query Processing for MNP

Figure 4: ENUM Message Flow for MNP and *Figure 5: ENUM Message Flow within EAGLE* show the overall flow of ENUM messages within the ENUM application for Mobile Number Portability (MNP). The flow of of ENUM messages within the ENUM application for MNP is described below.

1. The ENUM Query is received on the ENUM card over the UDP port.

2. If the incoming Query is received from a client IP address that is not in the Access Control List (ENUMACL table), the ENUM Query is rejected.
3. The ENUM Query is validated. If the ENUM Query is invalid, then an Error Response is sent to the originator of ENUM Query.
4. The ENUM Query domain is verified. If the ENUM Query domain is other than E.164 ARPA, then an Error Response is sent to the originator.
5. The ENUM Query is decoded. Number conditioning is performed on the digits string in the Query to extract the E.164 DN.
6. **Incoming DN Digits as Lookup Key:** Determine the number of digits from the incoming DN to be used as a lookup key for both the RxDDB and ENUM databases:
 - If the number of digits from the incoming DN is greater than or equal to the MAXDNDIGS option in the ENUMOPTS table, then use the first MAXDNDIGS digits for the lookup key.
 - If the number of digits from the incoming DN is less than the MAXDNDIGS option in the ENUMOPTS table, then use all of the incoming digits in DN as the lookup key.
7. An RxDDB lookup with the lookup key determined in item 6 is performed in the Individual DN table of the RxDDB.
8. If the Incoming DN is found in Individual DN table of the RxDDB with an associated Entity ID (RN/SP), use that Entity ID to retrieve the associated Profile ID from the ENUM Profile Selection table (ENUMPRID). If a Profile ID is found, use that to generate the ENUM Response. Otherwise, form the ENUM Response as shown below in *Default Profile Response*.
9. If the Incoming DN is found in the Individual DN table of the RxDDB without an associated Entity ID (RN/SP), then a lookup is performed in the ENUM DN Block Profile table (ENUMDNBK) with the incoming DN digits determined in item 6 as the lookup key. If the Profile ID is found, then use that to generate the ENUM Response. Otherwise, form the ENUM Response as shown below in *Default Profile Response*.
10. If the incoming DN digits determined in item 6 are not found in the Individual DN table of the RxDDB, then an RxDDB DN Block table lookup is performed
11. If the incoming DN digits determined in item 6 are found in the RxDDB DN Block table with an associated Entity ID (RN/SP), use that Entity ID to retrieve the associated Profile ID from the ENUM Profile Selection table (ENUMPRID). If a Profile ID is found, use that to generate the ENUM Response. Otherwise, form the ENUM Response as shown below in *Default Profile Response*.
12. If the incoming DN digits determined in item 6 are not found in the RxDDB DN Block table, then a lookup is performed in the ENUM DN Block Profile table (ENUMDNBK) with the incoming DN digits determined in item 6 as the lookup key. If a Profile ID is found, use that to generate the ENUM Response. Otherwise, form the ENUM Response as shown below in *Default Profile Response*.

Default Profile Response

If the Default Profile is RTYPE = NS, then send an ENUM Response message with RCODE = 0 and NS in the Authority Section.

If the Default Profile is RTYPE = NAPTR and QTYPE = NAPTR, then send an ENUM NAPTR Response message with RCODE = 0.

Otherwise, send an ENUM Error Response message with RCODE=3 (Non-Existent Domain).

See *Figure 6: ENUM Default Profile Response*.

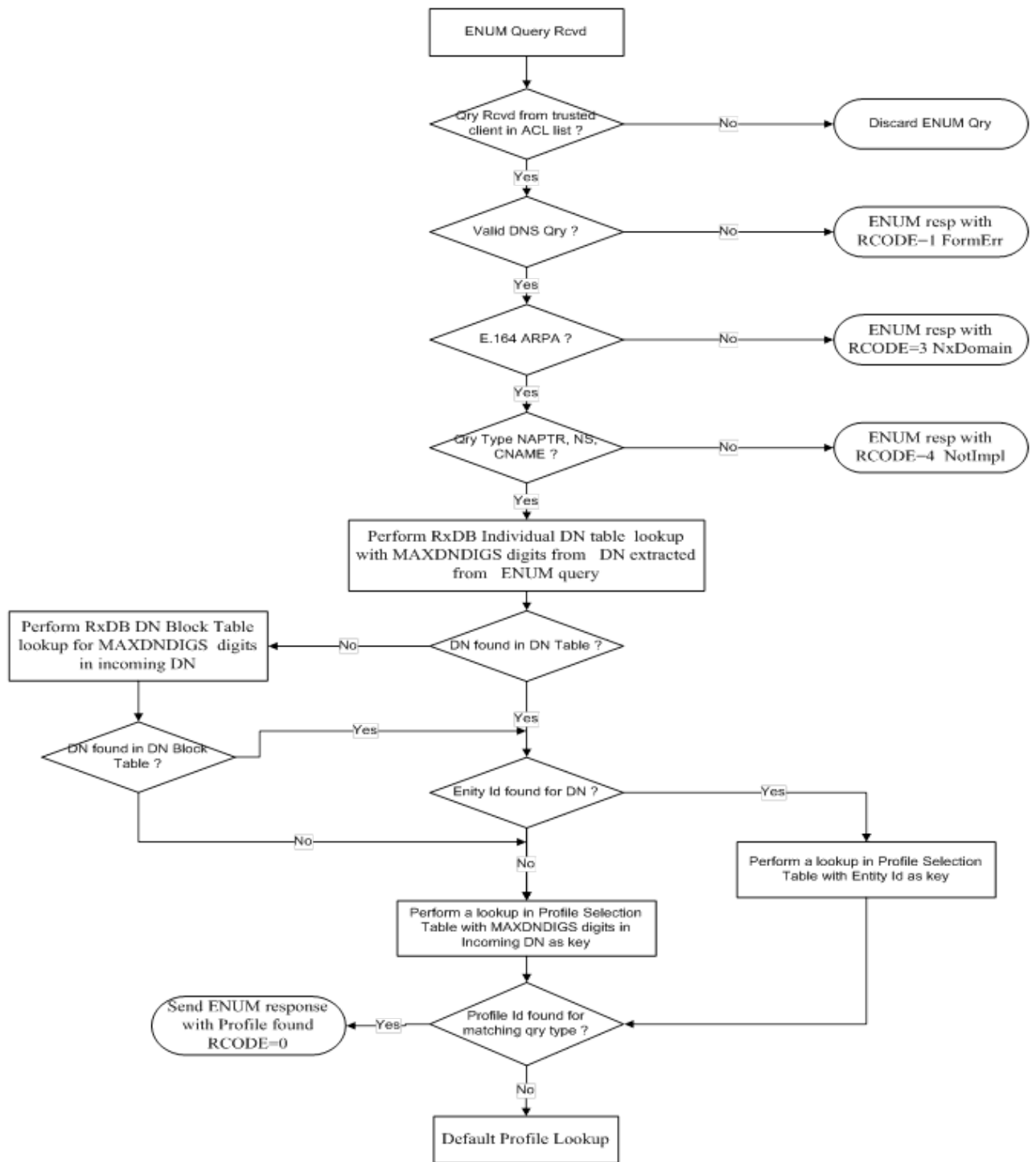

Figure 4: ENUM Message Flow for MNP

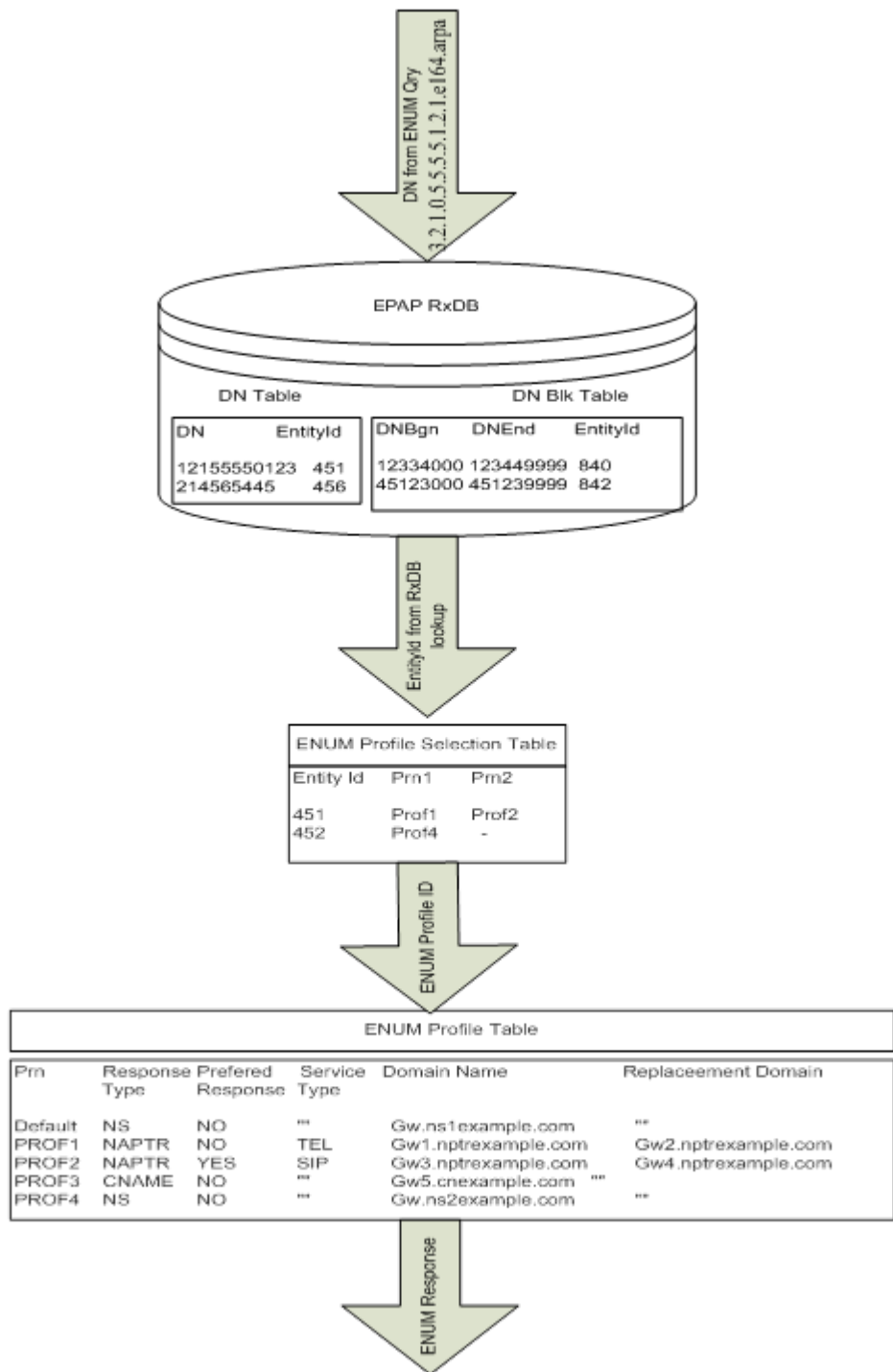

Figure 5: ENUM Message Flow within EAGLE

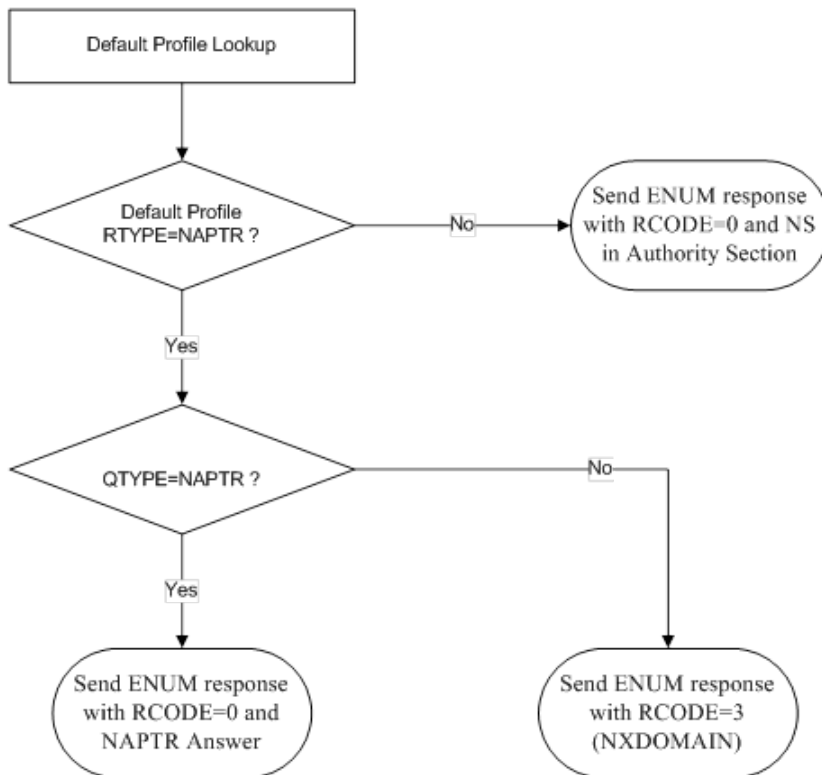

Figure 6: ENUM Default Profile Response

MNP RxDDB Lookup

For EAGLE with MNP support, the ENUM Response generated for a specific ENUM Query is determined by the result of RxDDB lookup and ENUM database lookup. [Figure 7: MNP RxDDB Database Lookup](#) shows the various MNP RxDDB database lookup scenarios during the processing of the ENUM Query.

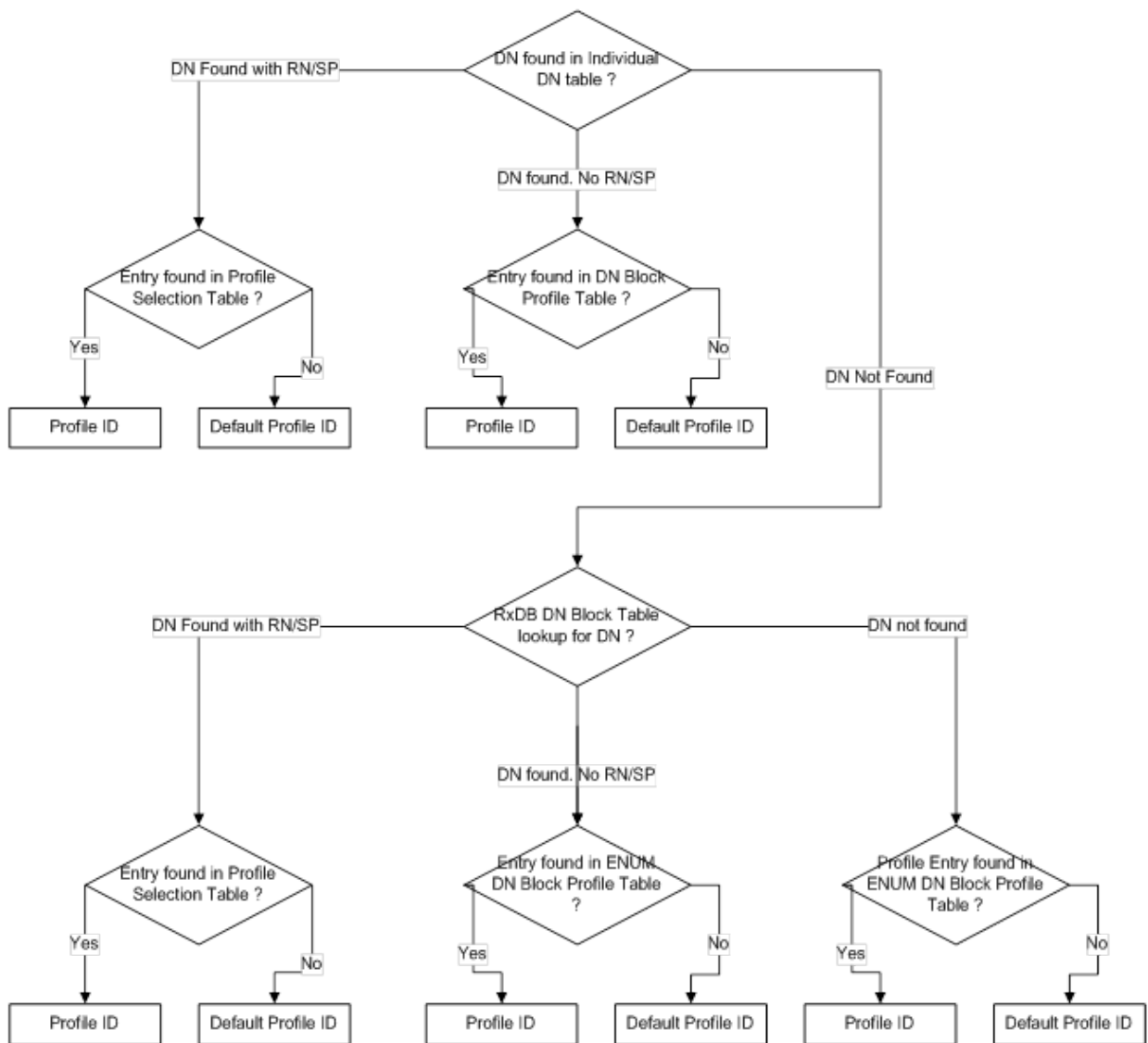

Figure 7: MNP RxD B Database Lookup

ENUM Feature Limitations

- If the ENUM card loses its EPAP connection, the cable from the ENUM card must be moved manually to the other switch and the ENUM card re-provisioned with the IP address of the other switch.
- If the EPAP database connection is lost, the ENUM card continues to process traffic with the copy of the database it had before the connection was lost, even if the database is stale.
- If the Signaling Network interface on an ENUM card stops functioning, the ENUM traffic corresponding to that Signaling Network interface is discarded.

- If the ENUM application stops functioning on an ENUM card, all open ENUM transactions handled by that card are lost.
- Load-balancing of ENUM on the EAGLE is not supported.
- STC Monitoring, SLAN Copy, and Fast Copy are not supported for ENUM Traffic.
- The EPAP Data Split feature must be turned on at the EAGLE with 240M EPAP database (120M DNs + 120 M IMSIs) to download the EPAP database on the ENUM card and bring the ENUM card to an in-service state (IS-NR).

ENUM Measurement Limitations

The measurement registers of ENUM-based reports store a maximum count of 4,294,967,295, due to the size of the register. An additional measurement peg above this limit rolls over the register count to 0.

This limitation constrains the number of ENUM cards in the system running at the maximum of 4000 TPS per ENUM card or the maximum TPS value of the maximum number of allowed ENUM cards (16) in the system.

- A maximum of 12 ENUM card can process at the maximum of 4000 TPS per card in the system without exceeding the count capacity.
- The maximum number of allowed ENUM cards (16) in the system can run at a maximum of 3100 TPS per card in the system without exceeding the count capacity.
- The maximum number of allowed ENUM cards (16) running at the maximum of 4000 TPS per card in the system can run for 18 hours before the count capacity is exceeded.

This measurement register limitation does not affect the processing of traffic. If the limits described above are not respected, then the value of the measurement register will roll over after reaching its maximum value and the peg count will be incorrect.

Hardware Requirements

The ENUM Mobile Number Portability and Tier One Address Resolution (ENUM) feature is supported on the E5-SM8G-B or SLIC card. A maximum of 16 E5-SM8G-B or SLIC cards per EAGLE can be configured as ENUM cards.

EPAP: An EPAP system can support up to 32 Service Module cards (E5-SM4G, E5-SM8G-B, or SLIC cards). Sixteen of the E5-SM8G-B or SLIC cards can be configured as ENUM cards running the ENUMHC/ENUM64 GPL. EPAP-related features that perform an RxDB lookup require Service Module cards (E5-SM4G, E5-SM8G-B, or SLIC cards) running the SCCPHC application.

A Third Party Load Balancer product is required to achieve load-sharing and fault tolerance for the ENUM application.

ENUM Card

The ENUM card is an E5-SM8G-B or SLIC card running the ENUMHC/ENUM64 GPL.

On the E5-SM8G-B card, Ethernet Interface A is used for EPAP/ELAP (ExAP) connectivity and Ethernet Interface B is used for the Signaling Network. [Table 30: E5-SM8G-B Faceplate IP Interface/Logical Link Status LED Operation for Port A](#) and [Table 31: E5-SM8G-B Faceplate IP Interface/Logical Link Status LED Operation for Port B](#) describe LED operations for the Ethernet Interfaces on E5-SM8G-B cards.

Table 30: E5-SM8G-B Faceplate IP Interface/Logical Link Status LED Operation for Port A

IP Interface Status	ExAP Connection		
	ExAP Connection Status	PORT A LED	ACT A LED
IP port not configured	N/A	Off	Off
Card inhibited			
Cable removed and/or not synched	N/A	Red	Red
Sync and/or act-ip-lnk	IP connection down	Green (100 Mbps) / Amber (1 Gbps)	Red
	IP connection up	Green (100 Mbps) / Amber (1 Gbps)	Green
dact-ip-lnk	N/A	Green	Red

Table 31: E5-SM8G-B Faceplate IP Interface/Logical Link Status LED Operation for Port B

IP Interface Status	Signaling Connection		
	Link/Connection Status	PORT B LED	ACT B LED
IP port not configured	N/A	Off	Off
Card inhibited			
Cable removed and/or not synched	N/A	Red	Red
Sync	Not configured	Green	Red
Sync and/or act-ip-lnk	Configured but ENUM UDP connection CLOSED (open=no)	Green	Red
	ENUM UDP Connection is ACTIVE (open=yes)	Green	Green
dact-ip-lnk	N/A	Green	Red

With the SLIC card, the port A Ethernet interface is used for ExAP connectivity and the port B Ethernet interface is used for the signaling network. As shown in [Figure 8: SLIC ENUM Card - Ethernet Interface Connections and Status LEDs](#), backplane DB26 ports A and B are labeled on the backplane for each slot of the shelf (that is, **Port <slot number> A** and **Port <slot number> B**). Backplane adaptors (part number 830-1102-03) are attached to backplane ports A and B. The adaptor connected to backplane port A supports the port A Ethernet interface through adaptor port P3, and the adaptor connected to backplane port B supports the port B Ethernet interface through adaptor port P3.

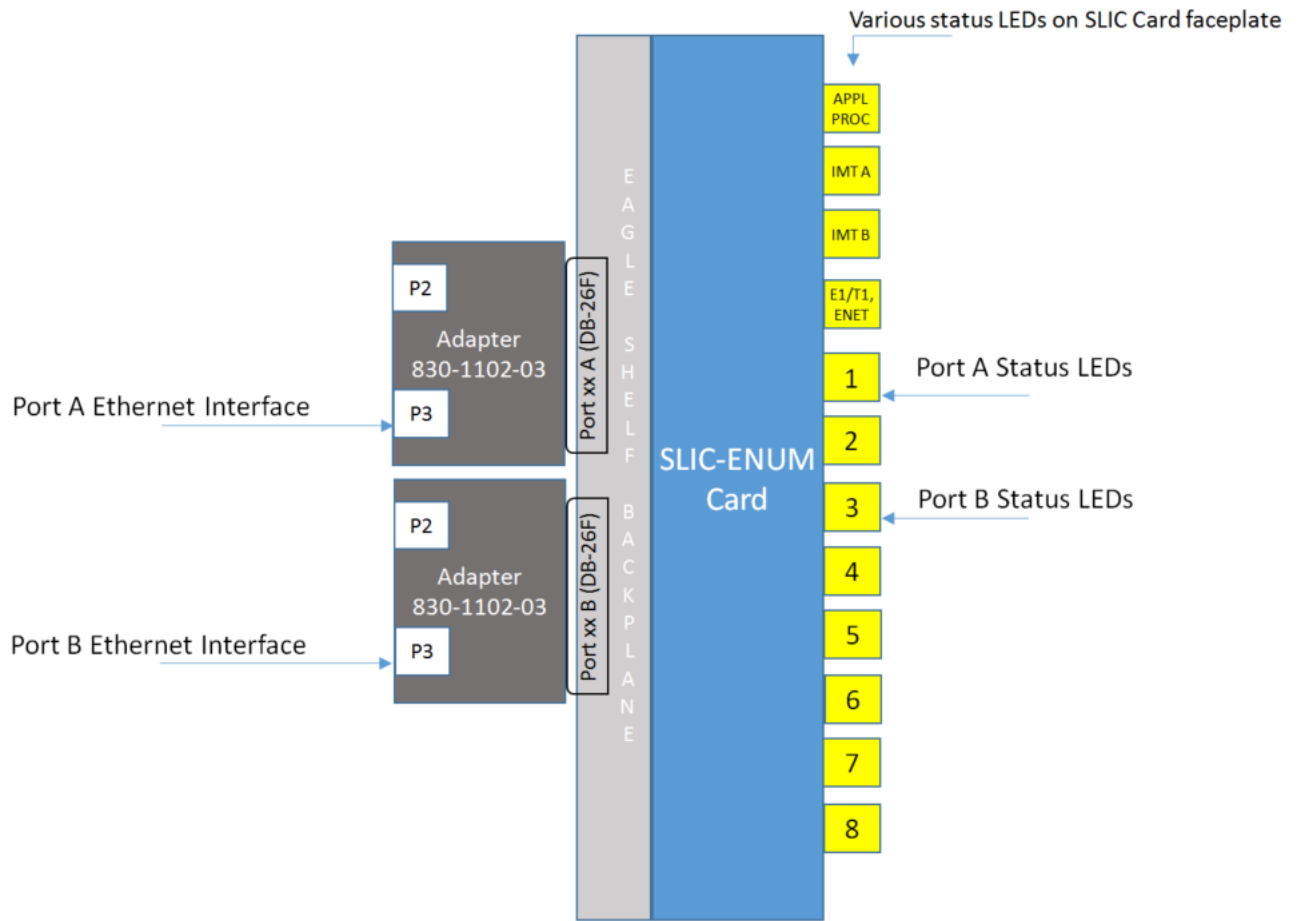

Figure 8: SLIC ENUM Card - Ethernet Interface Connections and Status LEDs

Figure 8: SLIC ENUM Card - Ethernet Interface Connections and Status LEDs also shows the status LEDs 1 and 3 that are on the SLIC faceplate, and their associations with the A and B Ethernet interface ports. The status LEDs on the SLIC faceplate are pictured in *Figure 9: SLIC Faceplate Status LEDs*.

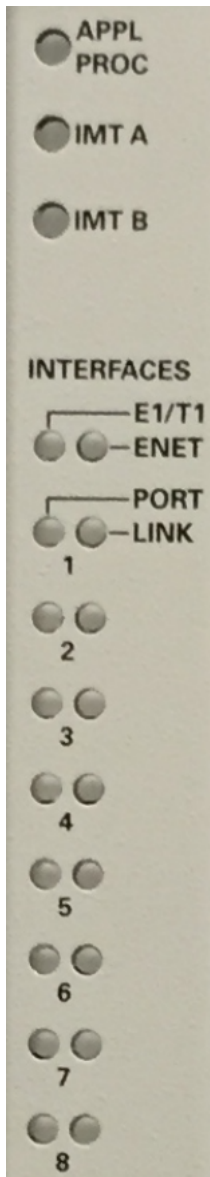

Figure 9: SLIC Faceplate Status LEDs

Table 32: SLIC Faceplate IP Interface/Logical Link Status LED Operation for Port A (Represented by LED 1) and Table 33: SLIC Faceplate IP Interface/Logical Link Status LED Operation for Port B (Represented by LED 3) describe LED operations for the Ethernet Interfaces on SLIC cards.

Table 32: SLIC Faceplate IP Interface/Logical Link Status LED Operation for Port A (Represented by LED 1)

IP Interface Status	ExAP Connection Status on IP Port A	ExAP Connection	
		PORT A LED	LINK A LED
IP port not configured	N/A	Off	Off

IP Interface Status	ExAP Connection Status on IP Port A	ExAP Connection	
		PORT A LED	LINK A LED
Card inhibited			
Cable removed and/or not synched	N/A	Red	Red
Sync and/or act-ip-lnk	IP connection down	Green (100 Mbps) / Amber (1 Gbps)	Red
	IP connection up	Green (100 Mbps) / Amber (1 Gbps)	Green
dact-ip-lnk	N/A	Green	Red

Table 33: SLIC Faceplate IP Interface/Logical Link Status LED Operation for Port B (Represented by LED 3)

IP Interface Status	Signaling Link/Connection Status on IP Port B	Signaling Connection	
		PORT B LED	LINK B LED
IP port not configured	N/A	Off	Off
Card inhibited			
Cable removed and/or not synched	N/A	Red	Red
Sync	Not configured	Green	Red
Sync and/or act-ip-lnk	Configured but ENUM UDP connection CLOSED (open=no)	Green	Red
	ENUM UDP Connection is ACTIVE (open=yes)	Green	Green
dact-ip-lnk	N/A	Green	Red

Chapter 3

Commands

Topics:

- *Introduction.....52*
- *EAGLE Commands Added to Support ENUM.....52*
- *EAGLE Commands Modified to Support ENUM.....55*
- *EAGLE Pass-Through Commands.....56*

This chapter contains brief descriptions of the EAGLE commands used for the configuration and control of the ENUM Mobile Number Portability and Tier One Address Resolution feature.

Introduction

This chapter contains the EAGLE commands used to support the ENUM Mobile Number Portability and Tier One Address Resolution (ENUM) feature. Refer to *Commands User's Guide* for complete command descriptions including parameter names, valid parameter values, examples, and dependencies.

EAGLE Commands Added to Support ENUM

The new commands to support configuration of the ENUM Mobile Number Portability and Tier One Address Resolution (ENUM) feature are described below. Refer to [ENUM Database](#) for descriptions of the ENUM-related tables.

ENUM Profile ID Tables Commands

These commands are used to add, modify, delete, and display entries in the ENUM Profile Selection table (ENUMPRID) and the ENUM DN Block Profile table (ENUMDNBK).

ent-enum-profsel This command adds a new entry in the ENUM Profile Selection table (ENUMPRID) mapping Entity ID to Profile ID or the ENUM DN Block Profile table (ENUMDNBK) mapping DN Blocks to Profile ID.

Command Examples:

- **ent-enum-profsel:entityid=1234:prn1=prof1:prn2=prof2**
- **ent-enum-profsel:sdn=9194841000:edn=914841999:prn1=prof1:prn2=prof2**

chg-enum-profsel This command modifies an existing entry in ENUM Profile Selection table (ENUMPRID) mapping Entity ID to Profile ID or ENUM DN Block Profile table (ENUMDNBK) mapping DN Blocks to Profile ID.

Command Examples:

- **chg-enum-profsel:entityid=1234:prn2=prof4**
- **chg-enum-profsel:sdn=9194841000:prn1=prof5**
- **chg-enum-profsel:edn=9194841999:prn2=prof6**

dlt-enum-profsel This command deletes an entry in ENUM Profile Selection table (ENUMPRID) for a specific Entity ID or an entry from ENUM DN Block Profile table (ENUMDNBK) for a specific DN Block.

Command Examples:

- **dlt-enum-profsel:entityid=1234**
- **dlt-enum-profsel:sdn=9194841000**
- **dlt-enum-profsel:edn=9194841999**

rtrv-enum-profsel This command displays an entry for a specific Entity ID in table ENUMPRID, an entry for a specific DN Block in table ENUMDNBK, or all entries in table ENUMPRID and ENUMDNBK

Command Examples:

- `rtrv-enum-profsel:entiyid=1234`
- `rtrv-enum-profsel:sdn=9194841000`
- `rtrv-enum-profsel:edn=9194841999`
- `rtrv-enum-profsel`

ENUM Profile Table Commands

These commands are used to add, modify, delete, and display entries in the ENUM Profile table (ENUMPROF) which contains data to generate the ENUM Response for the supported Resource Record formats: NAPTR, NS, CNAME.

ent-enum-prof This command adds a new entry in the ENUM Profile table (ENUMPROF) containing the ENUM Response Resource Records (RRs) in the supported formats.

Command Examples:

- `ent-enum-prof:prn=prof1:rtype=naptr:sparm=pstntel`
- `ent-enum-prof:prn=prof2:rtype=ns:rpdomain=gw100.nc.oracle.com`

chg-enum-prof This command changes an existing entry in the ENUM Profile table (ENUMPROF) containing the ENUM Response Resource Records (RRs) in the supported formats.

Command Examples:

- `chg-enum-prof:prn=prof1:rrdomain=gw4.example.com`
- `chg-enum-prof:prn=pr3:rpdomain=def.oracle.com`

dlt-enum-prof This command deletes an entry in the ENUM Profile table (ENUMPROF).

Command Examples:

- `dlt-enum-prof:prn=prof1`
- `dlt-enum-prof:prn=pr3`

rtrv-enum-prof This command displays an entry for a specific Profile ID or all entries in the ENUM Profile table (ENUMPROF).

Command Examples:

- `rtrv-enum-prof:prn=prof1`
- `rtrv-enum-prof:rtype=naptr`
- `rtrv-enum-prof`

ENUM Access Control List Table Commands

These commands are used to add, delete, and display entries in the ENUM Access Control List table (ENUMACL) which contains IP addresses of trusted ENUM clients.

ent-enum-acl This command adds a new entry of the IP address of a trusted ENUM client to the ENUM Access Control List table (ENUMACL).

Command Examples:

- `ent-enum-acl:ipaddr=10.250.8.120`

- **ent-enum-acl:ipaddr=10.240.*.***

dlt-enum-acl This command deletes an entry from the ENUM Access Control List table (ENUMACL).

Command Examples:

- **dlt-enum-acl:ipaddr=10.250.8.120**
- **dlt-enum-acl:ipaddr=10.248.6.66**

rtrv-enum-acl This command displays a specific entry or all entries in the ENUM Access Control List table (ENUMACL).

Command Examples:

- **rtrv-enum-acl**
- **rtrv-enum-acl:ipaddr=10.248.13.9**

ENUM Options Table Commands

These commands are used to change and display ENUM-specific data in the ENUM Options table (ENUMOPTS).

chg-enumopts This command changes the ENUM-specific data in the ENUM Options table (ENUMOPTS).

Command Examples:

- **chg-enumopts:conglvl1=50:congrlvl2=85:cngntfy=yes:cngrcode=11**
- **chg-enumopts:maxdndigs=12**
- **chg-enumopts:conglvl1=50**
- **chg-enumopts:conglvl2=10**
- **chg-enumopts:cngntfy=yes**
- **chg-enumopts:cngrcode=6**

rtrv-enumopts This command displays the ENUM-specific data in the ENUM Options table (ENUMOPTS). This command has no parameters.

Command Example: **rtrv-enumopts**

ENUM Feature Verification Command

The **rept-stat-enum** command displays the overall status of the ENUM service on the EAGLE. If the **rept-stat-enum** command is entered without any parameters, the displayed status includes the per-ENUM-card status and TPS, the total ENUM system statistics, and the ENUM-related alarms. The **rept-stat-enum** command is used with the **rept-stat-db** command, which reports database status, to display the various statuses which verify that the ENUM service is operating correctly.

Command Examples:

- **rept-stat-enum**
- **rept-stat-enum:peakreset=yes:loc=1101**
- **rept-stat-enum:loc=1101**
- **rept-stat-enum:mode=perf**

EAGLE Commands Modified to Support ENUM

These commands are modified as described below to support the ENUM Mobile Number Portability and Tier One Address Resolution (ENUM) feature.

Table 34: EAGLE Commands Modified to Support ENUM

Modifications	Affected Commands
Generate measurements reports and FTPed ENUM measurements data	rept-ftp-meas
Verify Warm Restart capability for ENUM cards	alw-card init-card init-network init-sys
Support ENUM tables	chg-upgrade-config copy-tbl copy-fta disp-disk-stats disp-tbl set-tbl
Support ENUM as a file type	act-ftp-trans
Support ENUMHC/ENUM64 GPL	act-gpl chg-gpl copy-gpl inh-card rept-stat-gpl rmv-card rst-card rtrv-gpl
Support appl=enumhc for ENUM cards	alw-card ent-card rept-stat-card
Support for auditing of ENUMHC/ENUM64 GPL and ENUM tables	aud-data

Modifications	Affected Commands
Support display of alarms	rept-stat-alm rept-stat-trbl
Support ENUM cards	rept-stat-mps rept-stat-rtdb rtrv-stp
Support status display of databases on ENUM cards	rept-stat-db
Allow enable/disable of the automatic generation and FTP transfer of ENUM measurement reports	chg-mtc-measopts
Support status display of ENUM scheduled maintenance measurements reports	rtrv-mtc-measopts
Support configuration/deletion of ENUM transport on ENUM cards	chg-ip-conn dlt-ip-conn ent-ip-conn
Support configuration/display of IP for ENUM cards	chg-ip-lnk rtrv-ip-lnk

EAGLE Pass-Through Commands

The ENUM application supports the following pass-through commands:

- **arp** - display and modify the Internet to Ethernet address translation tables used by the address resolution protocol
- **connmgr** - connection manager event logging services used to display different connection details of the card
- **cpum** - display cpu utilization
- **ee** - Eagle Eyes support on ENUM cards for capturing ENUM packet wireshark traces
- **msucount** - display number of queries and responses for an ENUM connection
- **netstat** - display network statistics from the tcp/ip stack
- **nslookup** - return the ip address for a given hostname or return a hostname for a given ip address
- **ping** - test for the presence of hosts on the network
- **sysstat** - display sys buffer, cpuconfig, database-related information
- **traceroute** - determine the path taken by a UDP message to a specified remote host

For additional details about the pass-through commands, refer to *Commands User's Guide*.

Chapter 4

Feature Configuration

Topics:

- [Introduction.....58](#)
- [ENUM Configuration.....58](#)

This chapter provides the procedure for configuring the EAGLE ENUM Mobile Number Portability and Tier One Address Resolution feature.

Introduction

This chapter contains example commands for configuring the ENUM Mobile Number Portability and Tier One Address Resolution (ENUM) feature of the Oracle Communications EAGLE.

Refer to *Commands User's Guide* for complete command descriptions including parameter names, valid parameter values, examples, and dependencies.

ENUM Configuration

Example commands for configuring the ENUM feature are as follows:

1. Enter the serial number.

```
ent-serial-num:serial=nt00001659
ent-serial-num:serial=nt00001659:lock=yes
```

2. Provision an ENUM card.

```
ent-card:loc=1105:type=dsm:appl=enumhc:data=epap
```

3. Configure Port A and Port B of an ENUM card.

```
chg-ip-lnk:port=a:submask=255.255.255.0:mcast=yes:ipaddr=192.168.120.11:loc=1101:duplex=full:speed=100
chg-ip-lnk:port=b:submask=255.255.255.0:mcast=yes:ipaddr=10.248.13.11:loc=1101:duplex=full:speed=100
```

4. Set up the ENUM connections.

```
ent-ip-host:host=tekelec.com:ipaddr=192.168.120.133:type=local
ent-ip-host:host=abc.com:ipaddr=250.001.001.001:type=remote
chg-ip-card:loc=1105:domain=tekelec.com:defrouter=10.248.13.9
ent-ip-conn:lport=1025:lhost=tekelec.com:prot=udp:cname=c1
chg-ip-conn:open=yes:cname=c1
alw-card:loc=1105
```

5. Enter profile entries in the ENUM Profile table (ENUMPROF).

```
ent-enum-prof:prn=prof1:rtype=naptr:sparm=pstnsip:rrdomain=gw1.example.com
ent-enum-prof:prn=prof2:rtype=ns:rpdomain=gw2.example.com
```

6. Enter an Entity ID entry in the ENUM Profile Selection table (ENUMPRID).

```
ent-enum-profsel:entityid=1234:prn1=prof2,prn3=prof1
```

7. Enter a DN Block entry in the ENUM DN Block Profile table (ENUMDNBK).

```
ent-enum-profsel:sdn=9194841000:edn=914841999:prn1=prof2,prn3=prof1
```

8. Enter the IP address of a trusted ENUM client in the ENUM ACL table(ENUMACL).

```
ent-enum-acl:ipaddr=10.250.8.120
```

9. Allow the card to come into service.

```
alw-card:loc=1105
```

Additional Configuration Commands

The ENUM Options commands (`chg-enumopts`, `rtrv-enumopts`) are used to change and display ENUM-specific data in the ENUM Options table (ENUMOPTS).

The `rept-stat-enum` command is used to display the overall status of the ENUM feature on the EAGLE.

Chapter 5

Measurements

Topics:

- [ENUM Measurements.....61](#)

This chapter describes the measurements information available from the EAGLE ENUM Mobile Number Portability and Tier One Address Resolution feature.

ENUM Measurements

Refer to *Measurements Reference* for information about measurement systems and reporting.

Refer to *Commands User's Guide* for descriptions of commands used to generate, schedule, and transfer measurements reports.

Refer to *Database Administration - System Management User's Guide* for provisioning information and procedures for these measurement systems:

- Measurements Platform
- E5-OAM Integrated Measurements

System Level Measurements

The ENUM application supports the measurements pegs described in [Table 35: ENUM System Level Measurements Pegs](#) on a per system basis.

Table 35: ENUM System Level Measurements Pegs

Register	Description
ENUMACLDISC	total number of ENUM queries discarded due to ACL validation failure
ENUMCNAMERX	total number of CNAME queries received
ENUMCNGDISC	total number of ENUM queries discarded due to congestion
ENUMNAPTRRX	total number of NAPTR queries received
ENUMNSRX	total number of NS queries received
ENUMQRYRJTD	total number of ENUM queries rejected by ENUM server
ENUMQRYRX	total number of ENUM queries received
ENUMTXDEFPR	total number of ENUM responses sent with default ENUM profile
ENUMTXRC0	total number of successful ENUM response sent (RCODE = 0)
ENUMTXRC1	total number of ENUM error response sent due to ENUM Query format error (Format Error RCODE = 1)
ENUMTXRC2	total number of ENUM error response sent due to ENUM Server failure (Server Failure Error RCODE = 2)
ENUMTXRC3	total number of ENUM error response sent due to non-existent domain error (Non-existent Domain Error RCODE = 3)
ENUMTXRC4	total number of ENUM error response sent due to not implemented error (Not Implemented Error RCODE = 4)
ENUMTXRC5	total number of ENUM error response sent due to refusal by ENUM server (Refused Error RCODE = 5)

Card Level Measurements

The ENUM application supports the measurements pegs described in [Table 36: ENUM Card Level Measurements Pegs](#) on a per card basis.

Table 36: ENUM Card Level Measurements Pegs

Register	Description
ENUMCACLDSC	total number of ENUM queries discarded due to ACL validation failure
ENUMCCNAMRX	total number of CNAME queries received
ENUMCCNGDSC	total number of ENUM queries discarded due to congestion
ENUMCNAPTRX	total number of NAPTR queries received
ENUMCNSRX	total number of NS queries received
ENUMCQRRJTD	total number of ENUM queries rejected by ENUM server
ENUMCQRYRX	total number of ENUM queries received
ENUMCTXDEFP	total number of ENUM responses sent with default ENUM profile
ENUMCTXRC0	total number of successful ENUM response sent (RCODE = 0)
ENUMCTXRC1	total number of ENUM error response sent due to ENUM Query format error (Format Error RCODE = 1)
ENUMCTXRC2	total number of ENUM error response sent due to ENUM Server failure (Server Failure Error RCODE = 2)
ENUMCTXRC3	total number of ENUM error response sent due to non-existent domain error (Non-existent Domain Error RCODE = 3)
ENUMCTXRC4	total number of ENUM error response sent due to not implemented error (Not Implemented Error RCODE = 4)
ENUMCTXRC5	total number of ENUM error response sent due to refusal by ENUM server (Refused Error RCODE = 5)

Entity Level Measurements

The ENUM application supports the following measurements peg described in [Table 37: ENUM Entity Level Measurements Pegs](#) on the basis of per Entity ID in the Entity ID table or per DN in the DN Block Profile table:

Table 37: ENUM Entity Level Measurements Pegs

Register	Description
ENUMENTMSGGS	total number of ENUM queries received or ENUM responses sent per entity

ACL Level Measurements

The ENUM application supports the measurements pegs described in [Table 38: ENUM ACL Level Measurements Pegs](#) on a per Access Control List (ACL) basis.

Table 38: ENUM ACL Level Measurements Pegs

Register	Description
ENUMACLQRCV	total number of ENUM queries received
ENUMACLQRJD	total number of ENUM queries rejected by ENUM server due to congestion and invalid ENUM messages causing error message to be sent to client
ENUMACLRC0	total number of successful ENUM response sent (RCODE = 0)
ENUMACLRC1	total number of ENUM error response sent due to ENUM Query format error (Format Error RCODE = 1)
ENUMACLRC2	total number of ENUM error response sent due to ENUM Server failure (Server Failure Error RCODE = 2)
ENUMACLRC3	total number of ENUM error response sent due to non-existent domain error (Non-existent Domain Error RCODE = 3)
ENUMACLRC4	total number of ENUM error response sent due to not implemented error (Not Implemented Error RCODE = 4)
ENUMACLRC5	total number of ENUM error response sent due to refusal by ENUM server (Refused Error RCODE = 5)

Chapter 6

Maintenance

Topics:

- [Alarms.....65](#)
- [UIMs.....65](#)
- [Thermal Management Parameters.....66](#)

This chapter describes the maintenance information available from the EAGLE ENUM Mobile Number Portability and Tier One Address Resolution feature. The information includes status, alarms (UAMs), and information messages (UIMs).

Alarms

Refer to *Unsolicited Alarm and Information Messages Reference* for descriptions and corrective procedures for alarms related to EAGLE features and functions.

For descriptions of and corrective procedures for MPS-related alarms, refer to *Alarms and Maintenance Guide* for EAGLE Application Processor.

This section lists new Unsolicited Alarm Messages (UAMs) used to support the EAGLE ENUM Mobile Number Portability and Tier One Address Resolution feature.

Table 39: Unsolicited Alarm Messages

UAM	Text	Description	Severity	Output Group
120	ENUM SYSTEM is not available	The system has no ENUM card which is Active/IS-NR.	Critical	SYSTEM
121	ENUM SYSTEM is available	The number of active ENUM cards (IS-NR state) are equal to or more than half the configured ENUM cards.	Normal	SYSTEM
122	ENUM SYSTEM normal, card(s) abnormal	The number of active ENUM cards (IS-NR state) are less than half the configured ENUM cards.	Major	SYSTEM
123	ENUM SYSTEM is removed	All ENUM cards are deleted from the system.	Normal	SYSTEM
124	ENUM Threshold -Level 1 exceeded	CONGLVL1 of ENUM card capacity has been exceeded.	Minor	CARD
125	ENUM Threshold -Level 2 exceeded	CONGLVL2 of ENUM card capacity has been exceeded.	Major	CARD
126	ENUM Threshold Condition cleared	Congestion was cleared on ENUM card.	Normal	CARD
127	ENUM card capacity exceeded	ENUM Card capacity has been exceeded.	Critical	CARD
629	ENUM Card TPS normal	ENUM card capacity is normal.	Normal	CARD

UIMs

This section lists new Unsolicited Information Messages (UIMs) used to support the EAGLE ENUM Mobile Number Portability and Tier One Address Resolution feature. Refer to *Unsolicited Alarm and Information Messages Reference* for complete descriptions of all UIM text and formats.

Table 40: Unsolicited Information Messages

UIM	Text	Description	Output Group
1463	ENUM connection established	ENUM connection has changed to an IS-NR state.	LINK
1464	ENUM connection terminated	ENUM connection is no longer established.	LINK
1465	ENUM card exceeded threshold TPS	The ENUM card TPS is equal to or more than 4000.	CARD
1466	ENUM Dflt Prof & query type mismatch	Default ENUM Profile response type and incoming query type do not match.	APSS
1467	ENUM msg decode failed	ENUM message validation fails.	APSS
1468	ENUM rcvd invalid msg	ENUM query was received with unsupported field values.	APSS
1469	ENUM request rejected	ENUM request was rejected coming from invalid IP addresses.	APSS
1471	ENUM matching prof for qry not found	ENUM Profile Table is missing entry of matching ENUM query type.	APSS

Thermal Management Parameters

The ENUM card supports thermal monitoring to protect the temperature-sensitive hardware components. The processor on the ENUM card can overheat as a result of high ambient temperature or airflow blockage. If the junction temperature increases above operating limits, the CPU halts and the ENUM card shuts itself down to prevent permanent, catastrophic damage. In the event of thermal shutdown all processor activity ceases.

To minimize data loss due to overheating, a graceful shutdown is implemented to detect and alert the user to the increasing thermal conditions. When the CPU temperature rises above nominal range and exceeds a thermal threshold (Temperature Level 1), a major alarm is raised against the ENUM card. If the temperature continues to increase and exceeds a second thermal threshold (Temperature Level 2), a critical alarm is raised against the ENUM card and traffic processing is stopped. When the second thermal threshold is exceeded, the application is notified from the operating system. The state of card will transition to the IN-ANR Restricted state. [Table 41: Thermal Management Parameters](#) shows the thermal events, actions, and alarms.

After the temperature decreases below the Temperature Level 2 threshold, the raised critical alarm is cleared and the corresponding major alarm is raised. When the temperature returns to its nominal range (below Temperature Level 1), a clearing alarm will be raised for the ENUM card and the ENUM card resumes traffic processing. These thermal thresholds (Temperature Level 1 and Temperature Level 2) are user-configurable using the `chg-thm-alm` command.

Table 41: Thermal Management Parameters

Board Temperature	Actions / Clearing Condition	UAM
Temperature Level 1 Exceeded on ENUM card; Major	Major alarm UAM 0078 raised on ENUM card	0078 Card temperature exceeds nominal lvl:T1
Temperature Level 2 Exceeded on ENUM card; Critical	Critical alarm UAM 0077 raised on ENUM card; State of ENUM card transitions to IS-ANR/Restricted	0077 Card temperature is at critical lvl:T2
Temperature abated (cooling below Temp Level 2 but at level 1)	Major alarm UAM 0078 raised on ENUM card; State of ENUM card transitions to IS-NR/Active	0078 Card temperature exceeds nominal lvl:T1
Temperature abated (cooling below Temp Level 1)	Major alarm UAM 0078 cleared	0079 Card temperature again at nominal level

C

CNAME Canonical Name

D

DNS Domain Name Services
Domain Name System

A system for converting Internet host and domain names into IP addresses.

E

ENUM Telephone Number Mapping - A technology for unifying various communications and telephone addresses for private and business numbers, facsimile and mobile phone numbers, SMS services, Instant Messaging and email. ENUM integrates legacy phone numbers with the Domain Name System (DNS). Users can access and maintain a directory that supports all forms of wired communication, mobile communications networks, and the Internet. ENUM allows for an end user to be reached on multiple devices via one phone number and allows the end user to determine which device to contact first or multiple devices simultaneously.
E.164 Number Mapping

N

NAPTR Name Authority Pointer
Domain Name System resource record that identifies possible URLs and numbers that can be returned.

N

NS

Network Server

Notification subscription

A subscription request made by a specific Subscribing Client to a specific subscriber public identity. It contains a list of the subscribed to Entity Alias values, the expiry time of the subscription, and associated flags. It also contains information necessary to build and send a Notification to the Subscribing Client. This is stored as an entry in the individual's SNO record object.

Name Server

National Security