

# Oracle Private Cloud Appliance Expansion Node Setup (part 1)

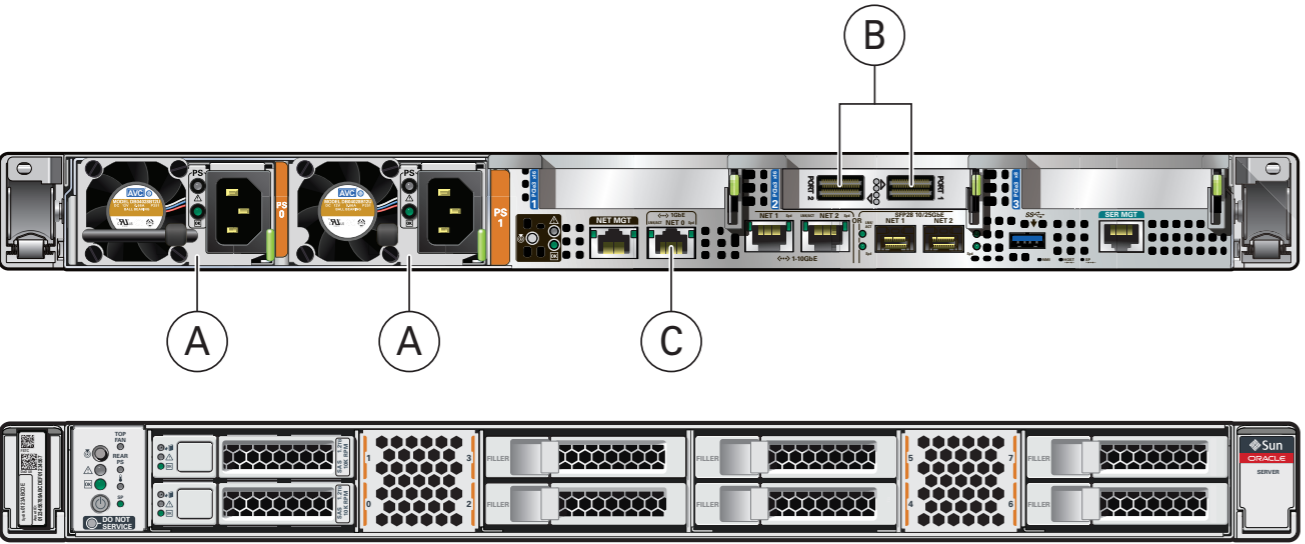

### Server Cabling Requirements

- A Power supplies
- B InfiniBand connectors
- C NET0 Ethernet port

**Note:** Cables are not included in the upgrade kit.  
All cables for all rack units are pre-installed in the appliance rack, and labeled according to the server cabling requirements.

### 1 Verify Installation Requirements

- A Review the safety guidelines and site checklists. Refer to the section "Review Safety Guidelines" in the Oracle Private Cloud Appliance Installation Guide.
- B Review and follow the safety precautions for rackmounting a server. Refer to the section "Rackmount Safety Precautions" in the Oracle Private Cloud Appliance Installation Guide.

### 2 Unpack the Expansion Node Upgrade Kit

- A Remove the packaging.
- B Verify that all items are included:
  - Rackmount kit incl. rack rails, mounting brackets, screws and Rackmounting Template
  - Cable management arm (CMA) assembly with installation instructions
  - Getting Started Guide
  - Legal and safety documents
  - Oracle Server

### 3 Prepare the Private Cloud Appliance rack

- A Remove the front and rear rack doors.
  - Unlock and open the front and rear doors.
  - Detach the top and bottom grounding straps by separating the banana jack (1).
  - Unlatch the bottom hinge, then the top hinge:
    - Pinch the two studs on the hinge towards the center of the hinge (2).
    - Rotate the studs away from the door (3) so that they stay in place and the hinge remains unlatched.
  - Lift the door away from the cabinet (4).
  - Repeat these steps for the two rear doors.
- B Remove the filler panel(s) where the expansion node will be installed. Studs on the back of the filler panel pull out of the holes in the rails. No screwdriver is required to remove them.
- C Remove the cable tray that holds the pre-installed cables in place at the rear side of the rack.
  - Detach the pre-installed cables from the cable tray on the rack unit
  - Use a No. 2 Phillips screwdriver to remove the M6 screws from the cable tray.
  - Remove the cable tray from the rack. Save cable tray and screws for future use.

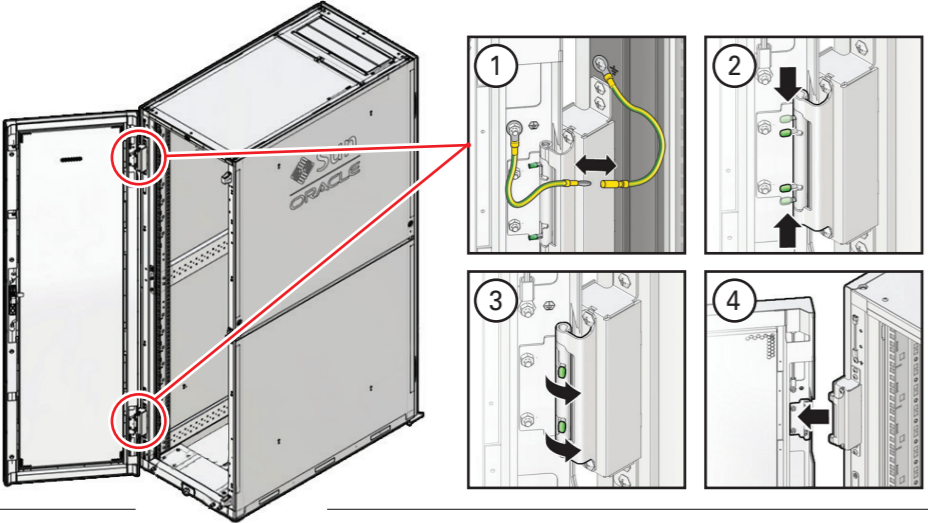

**CAUTION:** The doors are heavy. Have one person hold the door in place while the other operates the hinge latching mechanism. Execute the steps carefully and in the correct order, to avoid damage to the hinges.

**Note:** Always populate the compute rack units starting from the bottom most open slot, and work your way up.

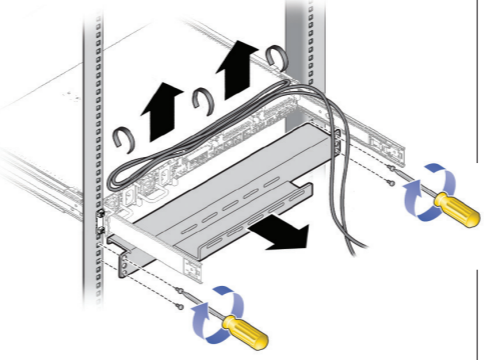

### 4 Install the Mounting Brackets on the Server

- A Install the mounting brackets on the server by placing the bracket against the server with the slide rail lock pointing toward the front and the five keyhole openings aligned with the locating pins on the server.
- B With the locating pins protruding through the keyhole openings, pull the bracket toward the front of the chassis until the clip locks into place with an audible click.
- C Verify that the rear locating pin has engaged the mounting bracket clip.
- D Repeat these steps to install the remaining mounting bracket on the other side of the server.

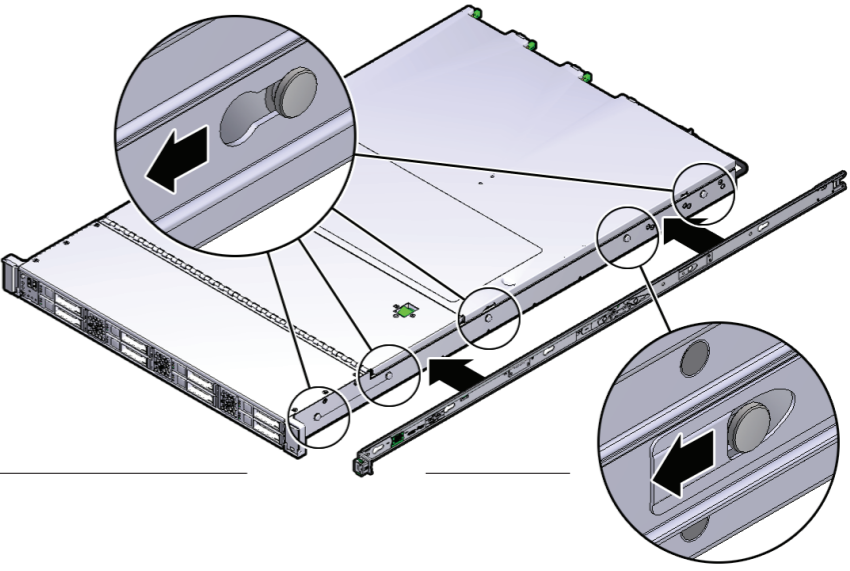

# Oracle Private Cloud Appliance Expansion Node Setup (part 1)

## 5 Attach the slide rail assemblies to the rack

A Orient the slide-rail assembly so that the ball-bearing track (1) is forward and secured in place by the locking mechanism (2).

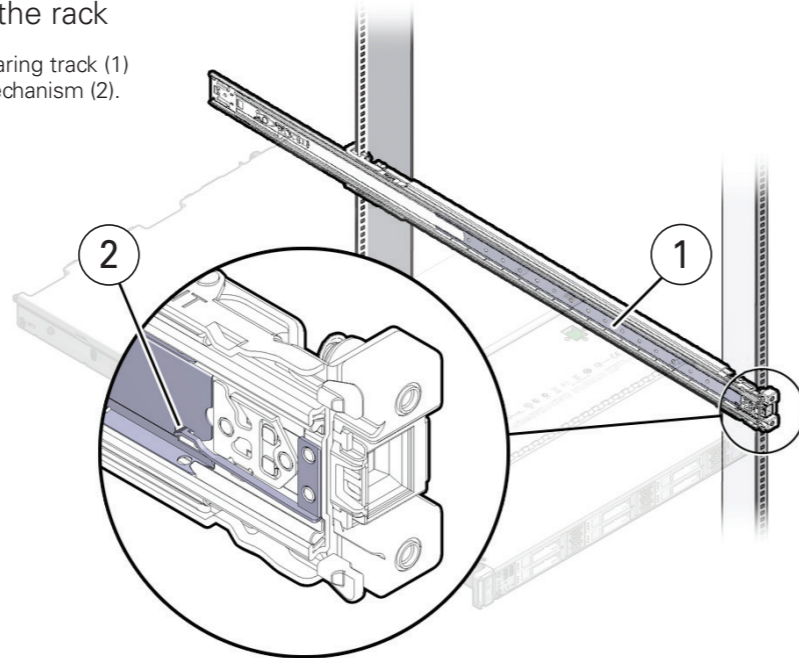

B Align the rear of the slide rail assembly against the inside of the rear rack rail, and push until the assembly locks into place with an audible click.

C Align the front of the slide rail assembly against the outside of the front rack rail, and push until the assembly locks into place with an audible click.

D Repeat these steps to install the remaining slide rail assembly to the other side of the rack.

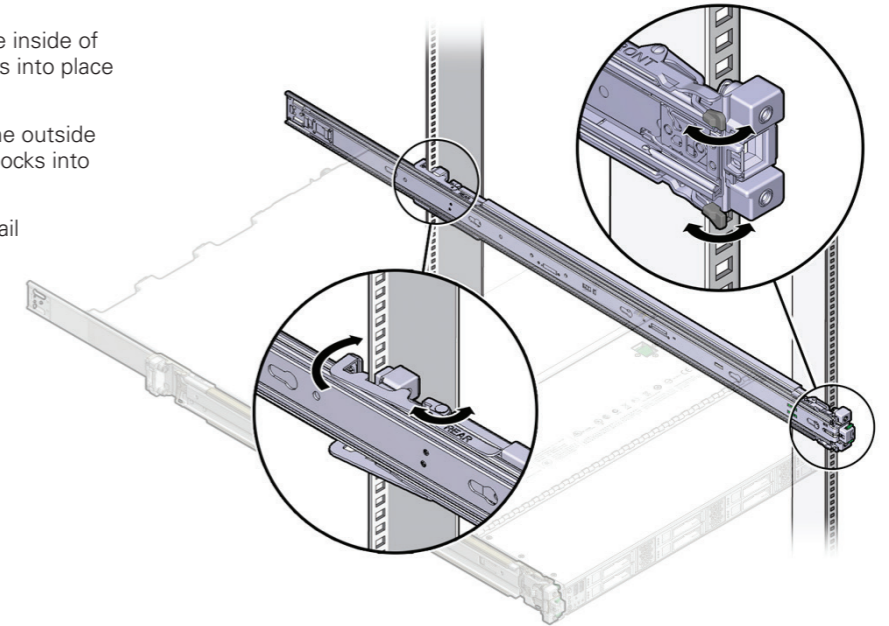

## 6 Install the server in the rack

A Push the slide-rails as far as possible into the slide-rail assemblies in the rack.

B Position the server so that the rear ends of the mounting brackets are aligned with the slide-rail assemblies that are mounted in the rack.

C Insert the mounting brackets into the slide-rails, and then push the server into the rack until the mounting brackets encounter the slide-rail stops (approximately 30cm or 12in).

**Note:** Always populate the compute rack units starting from the bottom most open slot, and work your way up.

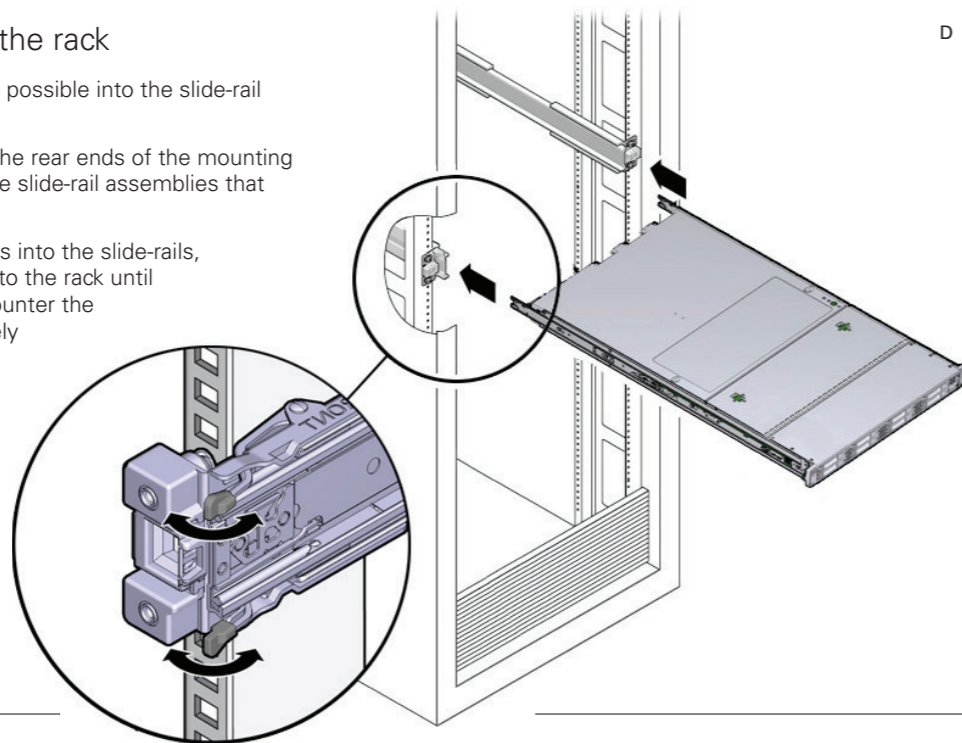

D Simultaneously push and hold the green slide-rail release buttons (1) on each mounting bracket while you push the server into the rack. Continue pushing the server into the rack until the slide-rail locks (2) (on the front of the mounting brackets) engage the slide-rail assemblies with an audible click.

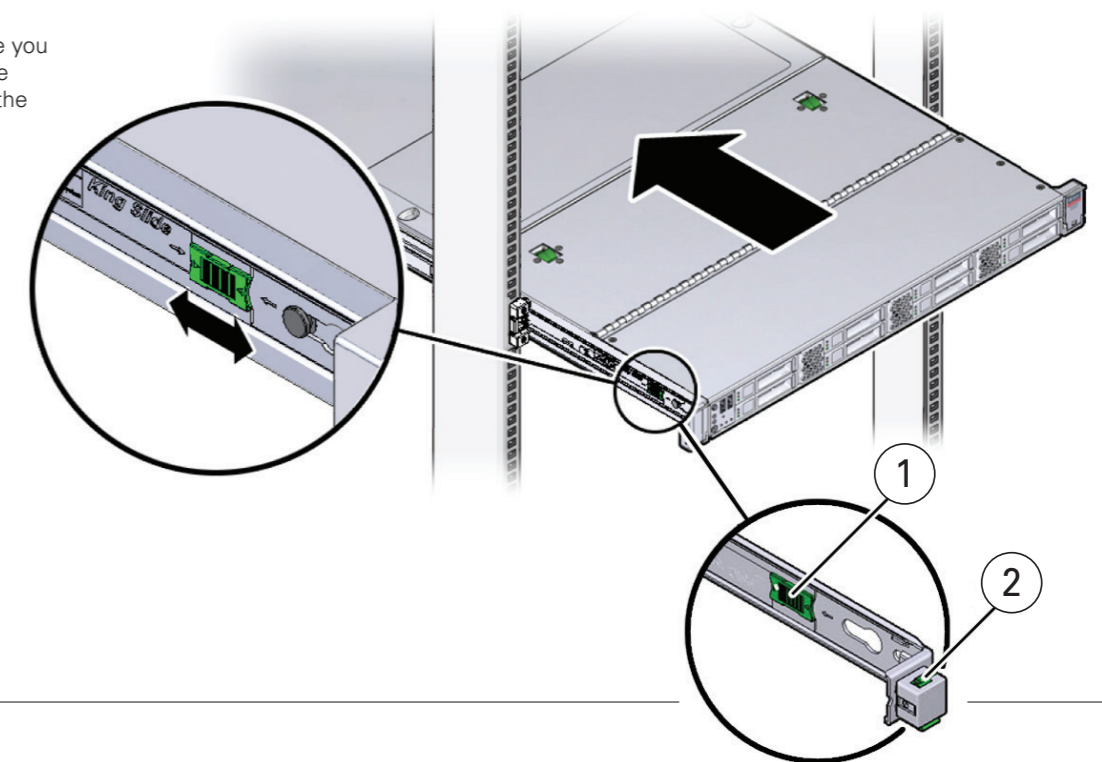

# Oracle Private Cloud Appliance Expansion Node Setup (part 2)

## 7 Install the cable management arm (CMA)

- A To make installation easier, extend the server approximately 13cm (5in) out of the front of the rack. Install the CMA from the back of the rack
- B Insert the CMA's connector A into the front slot on the left slide-rail until it locks into place with an audible click.

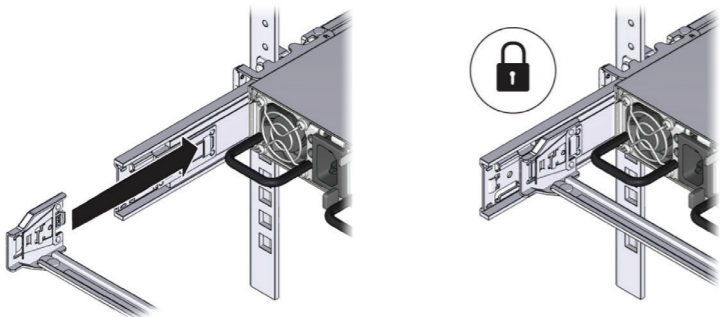

- C Insert the CMA's connector B into the front slot on the right slide-rail until it locks into place with an audible click.

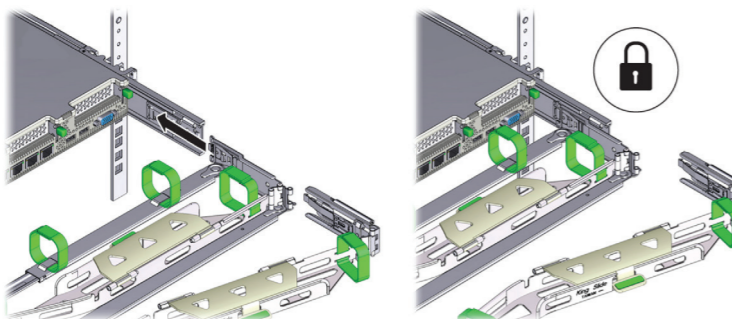

- D Align connector C with the slide-rail so that the locking spring is positioned inside (server side) of the right slide-rail.

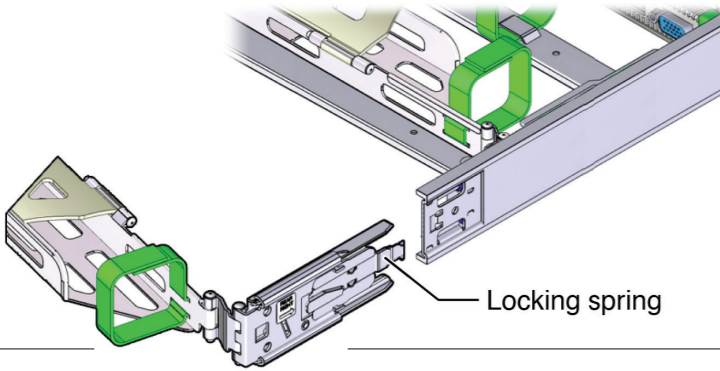

- E Insert connector C into the right side-rail until it locks into place with an audible click.

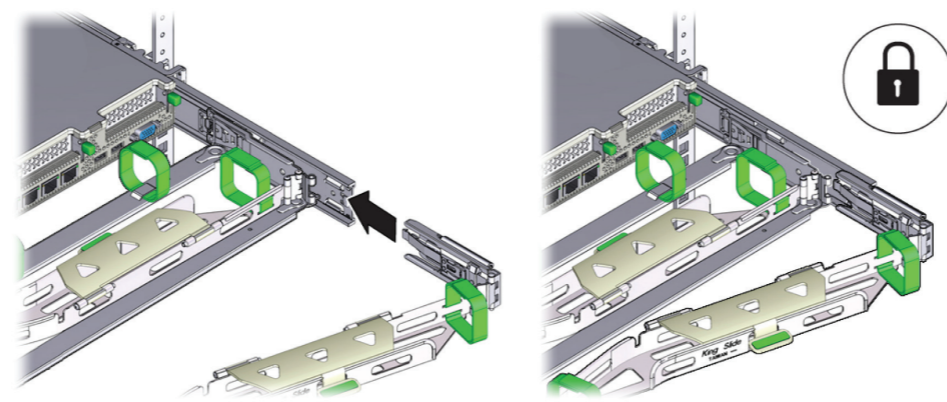

- F Remove the tape that secures the slide-rail latching bracket to connector D and ensure that the latching bracket is properly aligned with connector D.

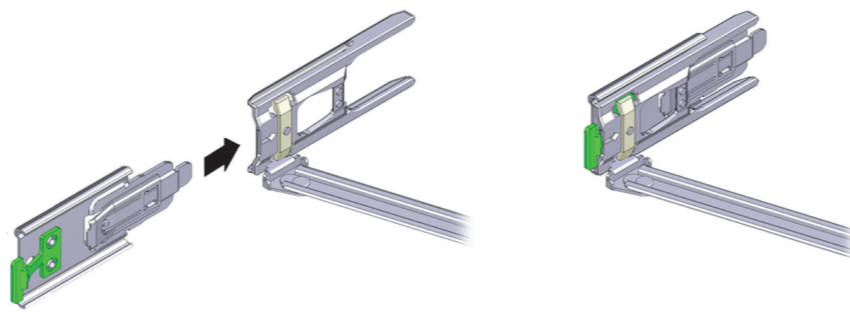

- G While holding the slide-rail latching bracket in place, insert connector D and its associated slide-rail latching bracket into the left slide-rail until connector D locks into place with an audible click.

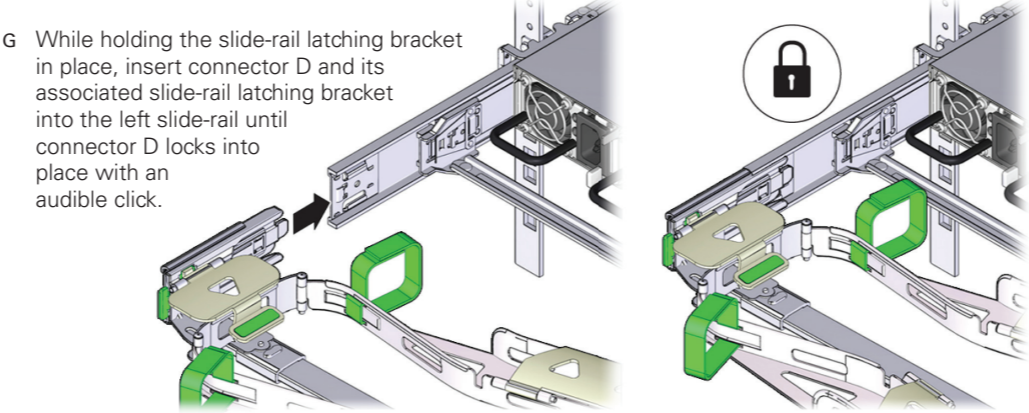

- H Gently tug on the four CMA connection points to ensure that the CMA connectors are fully seated before you allow the CMA to hang by its own weight.
- I Verify that the slide-rails and the CMA are operating properly before routing cables through the CMA.
  - Extend the server from the front of the rack until the CMA is fully extended.
  - Simultaneously pull and hold the two green release tabs (one on each side of the server) toward the front of the server while you push the server into the rack. As you push the server into the rack, verify that the CMA retracts without binding.
  - Continue pushing the server into the rack until the slide-rail locks (on the front of the server) engage the slide-rail assemblies with an audible click.

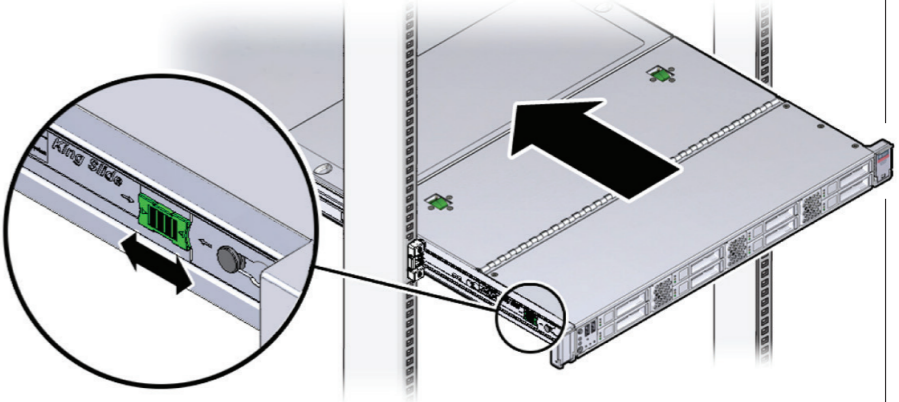

# Oracle Private Cloud Appliance Expansion Node Setup (part 2)

## 8 Cable the server

A Connect the pre-installed power and data cables of the appropriate rack unit to the back of the expansion node, as indicated in the Server Cabling Requirements on page 1.

Start by connecting the data cables; then connect the power cables. This allows the controller software to detect the new compute node and initiate the provisioning process.

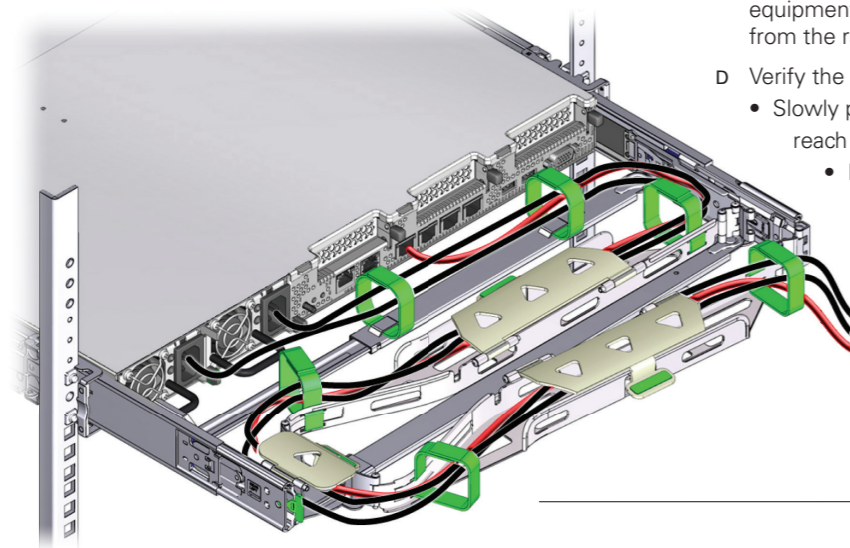

B Open the CMA cable covers, route server cables through the CMA's cable troughs, close the cable covers, and secure the cables with the six Velcro straps. Start with the front-most cable trough, then through the small cable trough, and finally through the rear-most cable trough.

C Ensure that the secured cables do not extend above the top or below the bottom of the server to which they are attached; otherwise, the cables might snag on other equipment installed in the rack when the server is extended from the rack or returned to the rack.

D Verify the operation of the CMA with all cables installed.
 

- Slowly pull the server out of the rack until the slide rails reach their stop.
  - Inspect the attached cables for any binding or kinks.
  - Verify that the CMA extends fully from the slide rails.

## 9 Push the server back into the rack

A Simultaneously pull and hold the two green release tabs (one on each side of the server) toward the front of the server while you push the server into the rack.

B As you push the server into the rack, verify that the CMA retracts without binding.

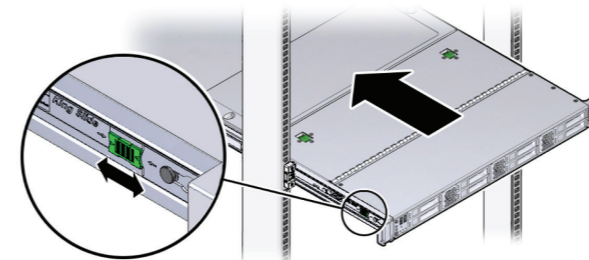

## 10 Replace the doors on the rack

A Lift the door into place, and align the pins on the door with the sleeve on the cabinet (1).  
 B On the top hinge, rotate the two studs on the hinge away from the center of the hinge (2). The pins snap into place (3).  
 C Repeat these steps to reinstall the other rack doors.  
 D Reconnect all grounding straps (4) on all doors.  
 E Close the doors. Optionally, lock the doors.

**CAUTION:** The doors are heavy. Have one person hold the door in place while the other operates the hinge latching mechanism. Execute the steps carefully and in the correct order, to avoid damage to the hinges.

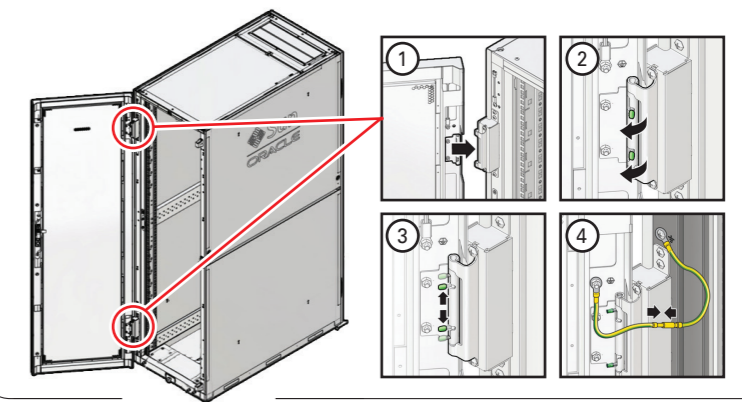

## 11 Automatic provisioning

The Appliance Dashboard detects that one or more new compute nodes are present in the rack. It automatically powers on the new hardware and executes the provisioning procedure.

The expansion compute nodes are incorporated seamlessly into the active system. This requires no further interventions by an administrator.

## 12 What's Next?

### Additional Resources

For more detailed instructions and information about safely using, maintaining, updating and expanding the system, refer to the online product documentation library.

### Oracle Help Center

For up-to-date product information, downloads and documentation, visit the Oracle Private Cloud Appliance product pages. Enter this URL: <http://www.oracle.com/technetwork/server-storage/private-cloud-appliance/>, or scan the QR code.

### Access to Oracle Support

Oracle customers have access to electronic support through My Oracle Support. For information, visit: <http://www.oracle.com/pls/topic/lookup?ctx=acc&id=info> or visit: <http://www.oracle.com/pls/topic/lookup?ctx=acc&id=trs> if you are hearing impaired.

**Note:** You cannot obtain software or support from Oracle without registered hardware and software SIs.



scan to access product overview