

# Oracle® 6.4 TB NVMe SSD v2 User Guide

ORACLE®

Part No: E99809-03  
June 2020



**Part No: E99809-03**

Copyright © 2019, 2020, Oracle and/or its affiliates.

**License Restrictions Warranty/Consequential Damages Disclaimer**

This software and related documentation are provided under a license agreement containing restrictions on use and disclosure and are protected by intellectual property laws. Except as expressly permitted in your license agreement or allowed by law, you may not use, copy, reproduce, translate, broadcast, modify, license, transmit, distribute, exhibit, perform, publish, or display any part, in any form, or by any means. Reverse engineering, disassembly, or decompilation of this software, unless required by law for interoperability, is prohibited.

**Warranty Disclaimer**

The information contained herein is subject to change without notice and is not warranted to be error-free. If you find any errors, please report them to us in writing.

**Restricted Rights Notice**

If this is software or related documentation that is delivered to the U.S. Government or anyone licensing it on behalf of the U.S. Government, then the following notice is applicable:

U.S. GOVERNMENT END USERS: Oracle programs (including any operating system, integrated software, any programs embedded, installed or activated on delivered hardware, and modifications of such programs) and Oracle computer documentation or other Oracle data delivered to or accessed by U.S. Government end users are "commercial computer software" or "commercial computer software documentation" pursuant to the applicable Federal Acquisition Regulation and agency-specific supplemental regulations. As such, the use, reproduction, duplication, release, display, disclosure, modification, preparation of derivative works, and/or adaptation of i) Oracle programs (including any operating system, integrated software, any programs embedded, installed or activated on delivered hardware, and modifications of such programs), ii) Oracle computer documentation and/or iii) other Oracle data, is subject to the rights and limitations specified in the license contained in the applicable contract. The terms governing the U.S. Government's use of Oracle cloud services are defined by the applicable contract for such services. No other rights are granted to the U.S. Government.

**Hazardous Applications Notice**

This software or hardware is developed for general use in a variety of information management applications. It is not developed or intended for use in any inherently dangerous applications, including applications that may create a risk of personal injury. If you use this software or hardware in dangerous applications, then you shall be responsible to take all appropriate fail-safe, backup, redundancy, and other measures to ensure its safe use. Oracle Corporation and its affiliates disclaim any liability for any damages caused by use of this software or hardware in dangerous applications.

**Trademark Notice**

Oracle and Java are registered trademarks of Oracle and/or its affiliates. Other names may be trademarks of their respective owners.

Intel and Intel Inside are trademarks or registered trademarks of Intel Corporation. All SPARC trademarks are used under license and are trademarks or registered trademarks of SPARC International, Inc. AMD, Epyc, and the AMD logo are trademarks or registered trademarks of Advanced Micro Devices. UNIX is a registered trademark of The Open Group.

**Third-Party Content, Products, and Services Disclaimer**

This software or hardware and documentation may provide access to or information about content, products, and services from third parties. Oracle Corporation and its affiliates are not responsible for and expressly disclaim all warranties of any kind with respect to third-party content, products, and services unless otherwise set forth in an applicable agreement between you and Oracle. Oracle Corporation and its affiliates will not be responsible for any loss, costs, or damages incurred due to your access to or use of third-party content, products, or services, except as set forth in an applicable agreement between you and Oracle.

**Pre-General Availability Draft Label and Publication Date**

Pre-General Availability: 2020-01-15

**Pre-General Availability Draft Documentation Notice**

If this document is in public or private pre-General Availability status:

This documentation is in pre-General Availability status and is intended for demonstration and preliminary use only. It may not be specific to the hardware on which you are using the software. Oracle Corporation and its affiliates are not responsible for and expressly disclaim all warranties of any kind with respect to this documentation and will not be responsible for any loss, costs, or damages incurred due to the use of this documentation.

**Oracle Confidential Label**

ORACLE CONFIDENTIAL. For authorized use only. Do not distribute to third parties.

**Revenue Recognition Notice**

If this document is in private pre-General Availability status:

The information contained in this document is for informational sharing purposes only and should be considered in your capacity as a customer advisory board member or pursuant to your pre-General Availability trial agreement only. It is not a commitment to deliver any material, code, or functionality, and should not be relied upon in making purchasing decisions. The development, release, and timing of any features or functionality described in this document remains at the sole discretion of Oracle.

This document in any form, software or printed matter, contains proprietary information that is the exclusive property of Oracle. Your access to and use of this confidential material is subject to the terms and conditions of your Oracle Master Agreement, Oracle License and Services Agreement, Oracle PartnerNetwork Agreement, Oracle distribution agreement, or other license agreement which has been executed by you and Oracle and with which you agree to comply. This document and information contained herein may not be disclosed, copied, reproduced, or distributed to anyone outside Oracle without prior written consent of Oracle. This document is not part of your license agreement nor can it be incorporated into any contractual agreement with Oracle or its subsidiaries or affiliates.

**Documentation Accessibility**

For information about Oracle's commitment to accessibility, visit the Oracle Accessibility Program website at <http://www.oracle.com/pls/topic/lookup?ctx=acc&id=docacc>.

**Access to Oracle Support**

Oracle customers that have purchased support have access to electronic support through My Oracle Support. For information, visit <http://www.oracle.com/pls/topic/lookup?ctx=acc&id=info> or visit <http://www.oracle.com/pls/topic/lookup?ctx=acc&id=trs> if you are hearing impaired.

**Référence: E99809-03**

Copyright © 2019, 2020, Oracle et/ou ses affiliés.

**Restrictions de licence/Avis d'exclusion de responsabilité en cas de dommage indirect et/ou consécutif**

Ce logiciel et la documentation qui l'accompagne sont protégés par les lois sur la propriété intellectuelle. Ils sont concédés sous licence et soumis à des restrictions d'utilisation et de divulgation. Sauf stipulation expresse de votre contrat de licence ou de la loi, vous ne pouvez pas copier, reproduire, traduire, diffuser, modifier, accorder de licence, transmettre, distribuer, exposer, exécuter, publier ou afficher le logiciel, même partiellement, sous quelque forme et par quelque procédé que ce soit. Par ailleurs, il est interdit de procéder à toute ingénierie inverse du logiciel, de le désassembler ou de le décompiler, excepté à des fins d'interopérabilité avec des logiciels tiers ou tel que prescrit par la loi.

**Exonération de garantie**

Les informations fournies dans ce document sont susceptibles de modification sans préavis. Par ailleurs, Oracle Corporation ne garantit pas qu'elles soient exemptes d'erreurs et vous invite, le cas échéant, à lui en faire part par écrit.

**Avis sur la limitation des droits**

Si ce logiciel, ou la documentation qui l'accompagne, est livré sous licence au Gouvernement des Etats-Unis, ou à quiconque qui aurait souscrit la licence de ce logiciel pour le compte du Gouvernement des Etats-Unis, la notice suivante s'applique :

U.S. GOVERNMENT END USERS: Oracle programs (including any operating system, integrated software, any programs embedded, installed or activated on delivered hardware, and modifications of such programs) and Oracle computer documentation or other Oracle data delivered to or accessed by U.S. Government end users are "commercial computer software" or "commercial computer software documentation" pursuant to the applicable Federal Acquisition Regulation and agency-specific supplemental regulations. As such, the use, reproduction, duplication, release, display, disclosure, modification, preparation of derivative works, and/or adaptation of i) Oracle programs (including any operating system, integrated software, any programs embedded, installed or activated on delivered hardware, and modifications of such programs), ii) Oracle computer documentation and/or iii) other Oracle data, is subject to the rights and limitations specified in the license contained in the applicable contract. The terms governing the U.S. Government's use of Oracle cloud services are defined by the applicable contract for such services. No other rights are granted to the U.S. Government.

**Avis sur les applications dangereuses**

Ce logiciel ou matériel a été développé pour un usage général dans le cadre d'applications de gestion des informations. Ce logiciel ou matériel n'est pas conçu ni n'est destiné à être utilisé dans des applications à risque, notamment dans des applications pouvant causer un risque de dommages corporels. Si vous utilisez ce logiciel ou matériel dans le cadre d'applications dangereuses, il est de votre responsabilité de prendre toutes les mesures de secours, de sauvegarde, de redondance et autres mesures nécessaires à son utilisation dans des conditions optimales de sécurité. Oracle Corporation et ses affiliés déclinent toute responsabilité quant aux dommages causés par l'utilisation de ce logiciel ou matériel pour des applications dangereuses.

**Marques**

Oracle et Java sont des marques déposées d'Oracle Corporation et/ou de ses affiliés. Tout autre nom mentionné peut correspondre à des marques appartenant à d'autres propriétaires qu'Oracle.

Intel et Intel Inside sont des marques ou des marques déposées d'Intel Corporation. Toutes les marques SPARC sont utilisées sous licence et sont des marques ou des marques déposées de SPARC International, Inc. AMD, Epyc, et le logo AMD sont des marques ou des marques déposées d'Advanced Micro Devices. UNIX est une marque déposée de The Open Group.

**Avis d'exclusion de responsabilité concernant les services, produits et contenu tiers**

Ce logiciel ou matériel et la documentation qui l'accompagne peuvent fournir des informations ou des liens donnant accès à des contenus, des produits et des services émanant de tiers. Oracle Corporation et ses affiliés déclinent toute responsabilité ou garantie expresse quant aux contenus, produits ou services émanant de tiers, sauf mention contraire stipulée dans un contrat entre vous et Oracle. En aucun cas, Oracle Corporation et ses affiliés ne sauraient être tenus pour responsables des pertes subies, des coûts occasionnés ou des dommages causés par l'accès à des contenus, produits ou services tiers, ou à leur utilisation, sauf mention contraire stipulée dans un contrat entre vous et Oracle.

**Date de publication et mention de la version préliminaire de Disponibilité Générale ("Pre-GA")**

Version préliminaire de Disponibilité Générale ("Pre-GA") : 15.01.2020

**Avis sur la version préliminaire de Disponibilité Générale ("Pre-GA") de la documentation**

Si ce document est fourni dans la Version préliminaire de Disponibilité Générale ("Pre-GA") à caractère public ou privé :

Cette documentation est fournie dans la Version préliminaire de Disponibilité Générale ("Pre-GA") et uniquement à des fins de démonstration et d'usage à titre préliminaire de la version finale. Celle-ci n'est pas toujours spécifique du matériel informatique sur lequel vous utilisez ce logiciel. Oracle Corporation et ses affiliés déclinent expressément toute responsabilité ou garantie expresse quant au contenu de cette documentation. Oracle Corporation et ses affiliés ne sauraient en aucun cas être tenus pour responsables des pertes subies, des coûts occasionnés ou des dommages causés par l'utilisation de cette documentation.

**Mention sur les informations confidentielles Oracle**

INFORMATIONS CONFIDENTIELLES ORACLE. Destinées uniquement à un usage autorisé. Ne pas distribuer à des tiers.

**Avis sur la reconnaissance du revenu**

Si ce document est fourni dans la Version préliminaire de Disponibilité Générale ("Pre-GA") à caractère privé :

Les informations contenues dans ce document sont fournies à titre informatif uniquement et doivent être prises en compte en votre qualité de membre du customer advisory board ou conformément à votre contrat d'essai de Version préliminaire de Disponibilité Générale ("Pre-GA") uniquement. Ce document ne constitue en aucun cas un engagement à fournir des composants, du code ou des fonctionnalités et ne doit pas être retenu comme base d'une quelconque décision d'achat. Le développement, la commercialisation et la mise à disposition des fonctions ou fonctionnalités décrites restent à la seule discrétion d'Oracle.

Ce document contient des informations qui sont la propriété exclusive d'Oracle, qu'il s'agisse de la version électronique ou imprimée. Votre accès à ce contenu confidentiel et son utilisation sont soumis aux termes de vos contrats, Contrat-Cadre Oracle (OMA), Contrat de Licence et de Services Oracle (OLSA), Contrat Réseau Partenaires Oracle (OPN), contrat de distribution Oracle ou de tout autre contrat de licence en vigueur que vous avez signé et que vous vous engagez à respecter. Ce document et son contenu ne peuvent en aucun cas être communiqués, copiés, reproduits ou distribués à une personne extérieure à Oracle sans le consentement écrit d'Oracle. Ce document ne fait pas partie de votre contrat de licence. Par ailleurs, il ne peut être intégré à aucun accord contractuel avec Oracle ou ses filiales ou ses affiliés.

#### **Accessibilité de la documentation**

Pour plus d'informations sur l'engagement d'Oracle pour l'accessibilité de la documentation, visitez le site Web Oracle Accessibility Program, à l'adresse : <http://www.oracle.com/pls/topic/lookup?ctx=acc&id=docacc>.

#### **Accès aux services de support Oracle**

Les clients Oracle qui ont souscrit un contrat de support ont accès au support électronique via My Oracle Support. Pour plus d'informations, visitez le site <http://www.oracle.com/pls/topic/lookup?ctx=acc&id=info> ou le site <http://www.oracle.com/pls/topic/lookup?ctx=acc&id=trs> si vous êtes malentendant.

# Contents

---

<b>Using This Documentation</b> .....	9
Product Documentation Library .....	9
Feedback .....	9
<b>Product Overview</b> .....	11
Oracle 6.4 TB NVMe SSD v2 Overview .....	11
About Oracle 6.4 TB NVMe SSD v2s .....	11
Status Indicators .....	12
About Oracle PCIe NVMe Switch Cards and Oracle 6.4 TB NVMe SSD v2s .....	13
Specifications .....	14
Product Specification .....	15
Characteristics .....	16
Usage Information .....	16
Drive Capacity and Performance .....	17
Electrical Specifications .....	18
Physical Dimensions .....	19
<b>Preparing Oracle 6.4 TB NVMe SSD v2 for Installation</b> .....	21
▼ Prepare for Installation .....	21
Required Tools .....	22
Ship Kit Contents .....	22
Observing Safety Precautions .....	24
General Safety Information .....	24
Safety Symbols .....	24
ESD Safety Measures .....	25
▼ Perform ESD Prevention Measures .....	25
Oracle 6.4 TB NVMe SSD v2 Optimization Guidelines .....	26

- Drive Volume Management ..... 27
- ▼ Update Your System to the Latest Software Release ..... 27
  
- Installing Oracle 6.4 TB NVMe SSD v2s** ..... 29
- Installation Overview ..... 29
- Oracle 6.4 TB NVMe SSD v2 Installation Tasks ..... 29
- ▼ Install a New Oracle 6.4 TB NVMe SSD v2 (CRU) ..... 30
  
- Servicing Oracle 6.4 TB NVMe SSD v2s** ..... 33
- Oracle 6.4 TB NVMe SSD v2 Service Overview ..... 33
- Component Serviceability ..... 34
- ▼ Replace an Existing Oracle 6.4 TB NVMe SSD v2 (CRU) ..... 35
- Troubleshooting Oracle 6.4 TB NVMe SSD v2 Cooling ..... 39
- Technical Support ..... 40
  
- Index** ..... 41

## Using This Documentation

---

- **Overview** – Provides specifications and describes how to install, administer, and service the Oracle 6.4 TB NVMe SSD v2.
- **Audience** – Trained technicians and authorized service personnel who have been instructed on the hazards within the equipment and qualified to remove and replace hardware.
- **Required knowledge** – Advanced experience troubleshooting and replacing hardware.

## Product Documentation Library

Documentation and resources for this product and related products are available at: <https://www.oracle.com/goto/oracleflashf640/docs>

## Feedback

Provide feedback about this documentation at: <https://www.oracle.com/goto/docfeedback>



# Product Overview

---

This section describes the specifications and capabilities of Oracle 6.4 TB NVMe SSD v2.

Review the following product information sections before you install or service your Oracle 6.4 TB NVMe storage drive.

Description	Links
Learn about Oracle 6.4 TB NVMe SSD v2 features and functions.	<a href="#">“Oracle 6.4 TB NVMe SSD v2 Overview” on page 11</a>
Review specifications and capabilities.	<a href="#">“Specifications” on page 14</a>

---

**Note** - To install the Oracle 6.4 TB NVMe SSD v2 in a specific server, refer to your server documentation. For information about restrictions and use of Oracle 6.4 TB NVMe SSD v2s on your server, see the most recent version of the server product notes.

---

## Oracle 6.4 TB NVMe SSD v2 Overview

These topics provide an overview of Oracle 6.4 TB NVMe SSD v2 features and functions:

- [“About Oracle 6.4 TB NVMe SSD v2s” on page 11](#)
- [“Status Indicators” on page 12](#)
- [“About Oracle PCIe NVMe Switch Cards and Oracle 6.4 TB NVMe SSD v2s” on page 13](#)

## About Oracle 6.4 TB NVMe SSD v2s

Oracle 6.4 TB NVMe SSD v2 is designed to deliver high-performance and reliable flash memory. This small form factor SSD storage drive interfaces with the server directly over

Gen3 PCI Express (PCIe) and provides a high-bandwidth, low-latency, flash-based caching tier for various enterprise workloads. Oracle 6.4 TB NVMe SSD integrates a high-performance Non-Volatile Memory Express (NVMe) controller interface. Oracle 6.4 TB NVMe SSD v2 is designed with advanced enterprise multi-level cell TLC 3D NAND 64-tier technology for high-level performance and write durability.

Oracle servers configured with Oracle 6.4 TB NVMe SSD v2s offer high performance with low latency and a low processor (CPU) burden. The Oracle 6.4 TB NVMe SSD v2 is a PCIe Gen3 storage drive that is designed with the high-performance controller interface – NVMe (Non-Volatile Memory Express), delivering leading performance, low latency, and high quality of service. Oracle 6.4 TB NVMe SSD v2 is a block storage device, with block sizing optimization capabilities. You can use the Oracle 6.4 TB NVMe SSD for either nonpersistent or persistent data.

The following illustration shows an Oracle 6.4 TB NVMe SSD v2.

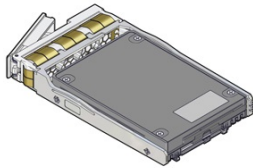

## Related Information



- [“Status Indicators” on page 12](#)
- [“About Oracle PCIe NVMe Switch Cards and Oracle 6.4 TB NVMe SSD v2s” on page 13](#)
- [“Specifications” on page 14](#)

## Status Indicators

Use Oracle 6.4 TB NVMe SSD v2 status indicators to determine the status of each drive and perform service actions as required. Three status indicator LEDs are located on the drive bracket to indicate status and diagnose NVMe storage drive issues.

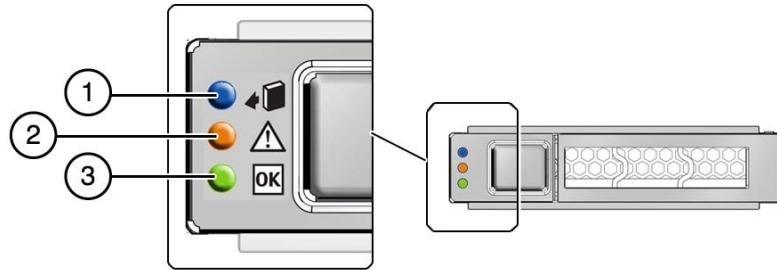
The following illustration shows status indicator LEDs for Oracle 6.4 TB NVMe SSD v2.



Call Out	Status LED	Icon and Color	Description
1	Ready to Remove	 Blue	Indicates that a drive can be removed during a hot-service operation. <ul style="list-style-type: none"> <li>■ OFF – Server is operating normally,</li> <li>■ STEADY ON – Lights when the storage drive is ready to be removed from the server in response to an action initiated from the server operating system.</li> </ul>
2	Fault-Service Required	 Amber	Indicates that the drive has experienced a fault condition. <ul style="list-style-type: none"> <li>■ OFF – Storage drive is operating normally,</li> <li>■ STEADY ON – A fault is present in the storage drive.</li> </ul>
3	OK/Activity	 Green	Indicates the drive's availability for use. Indicates the operational state of the storage drive. <ul style="list-style-type: none"> <li>■ OFF – AC power is not present or Oracle ILOM boot is not complete.</li> <li>■ BLINK – Blinks to show storage drive activity. Storage drive indicator blink rates vary by activity.</li> <li>■ STEADY ON – The storage drive is functioning normally.</li> </ul>

- [“About Oracle 6.4 TB NVMe SSD v2s” on page 11](#)
- [“Servicing Oracle 6.4 TB NVMe SSD v2s” on page 33](#)

## About Oracle PCIe NVMe Switch Cards and Oracle 6.4 TB NVMe SSD v2s

Oracle 6.4 TB NVMe SSD v2s on some servers require a PCIe low-profile form factor NVMe switch controller card to facilitate connections between the host root port and the NVMe devices. Oracle PCIe NVMe Switch Card provides high bandwidth and low latency for up to four NVMe drives. Oracle PCIe NVMe Switch Card plugs into a low profile x4 PCIe Gen3 card slot and uses sixteen lanes to support four NVMe storage drive devices.

The following illustration shows four Oracle 6.4 TB NVMe SSD v2s connected to one Oracle PCIe NVMe Switch Card in an x86 server configuration.

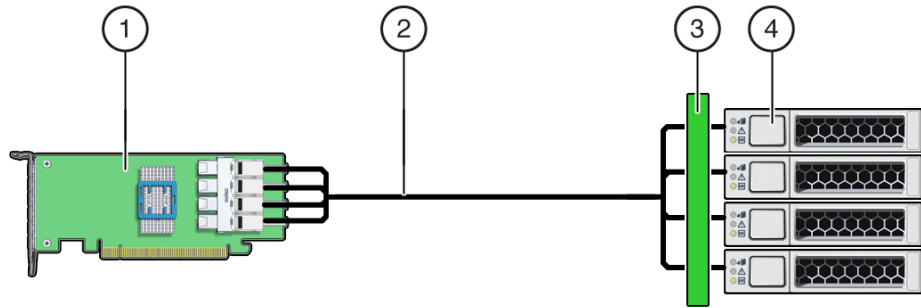

Call Out	Description
1	Oracle PCIe NVMe Switch Card
2	Server NVMe Connecting Cable
3	Server NVMe Disk Backplane
4	Oracle 6.4 TB NVMe SSD v2 storage drives in NVMe bays

### Related Information

- [“Specifications” on page 14](#)
- [“About Oracle 6.4 TB NVMe SSD v2s” on page 11](#)
- [“Oracle 6.4 TB NVMe SSD v2 Product Notes” in Oracle Flash Accelerator F640 PCIe Card v2 and Oracle 6.4 TB NVMe SSD v2 Product Notes.](#)

## Specifications

The following sections provide the specifications and capabilities of Oracle 6.4 TB NVMe SSD v2:

- [“Product Specification” on page 15](#)

- [“Characteristics” on page 16](#)
- [“Usage Information” on page 16](#)
- [“Drive Capacity and Performance” on page 17](#)
- [“Electrical Specifications” on page 18](#)
- [“Physical Dimensions” on page 19](#)

---

**Note** - For server specifications, see the most recent version of the server product notes.

---

## Product Specification

Oracle 6.4 TB NVMe SSD v2 general specifications are listed in the following table.

Specification	Value
Device name	7361456_ICRPC2DD2ORA6.4T
Manufacturing name	SSDPECKE064T8S
Form factors	2.5-inch SFF (small form factor): U.2 2.5-inch 15mm, SFF-8639 compatible connector (U.2), 15mm Z-height  3.5-inch Form Factor (Oracle Server X8-2L)
PCIe interface	PCIe Gen3 x4 lanes
NAND	High-endurance Intel TLC 3D NAND flash memory 64-tier
Flash controller	One Intel flash memory NVMe controller ASIC
Flash controller firmware	Intel custom and proprietary PCIe to NAND flash controller
Product Compliance	<ul style="list-style-type: none"> <li>■ NVM Express 1.2b</li> <li>■ PCI Express Base Specification Rev 3.1</li> <li>■ PCI Express Card Electro-Mechanical (CEM) Specification Rev 3.0</li> <li>■ Enterprise SSD Form Factor Version 1.0a</li> </ul>
Product ecological compliance	RoHS
Certifications and declarations	UL, CE, C-Tick, BSMI, KCC, Microsoft WHCK, VCCI

### Related Information

- [“Oracle 6.4 TB NVMe SSD v2 Overview” on page 11](#)

## Characteristics

Oracle 6.4 TB NVMe SSD v2 has the following hardware and software characteristics.

Characteristic	Value
Minimum operating system versions	Refer to “Supported Hardware and Software” in <i>Oracle Flash Accelerator F640 PCIe Card v2 and Oracle 6.4 TB NVMe SSD v2 Product Notes</i> for minimum operating system versions, hardware, firmware, and software compatibility.
Life monitoring capability	Provides alerts for proactive replacement of the drive before the endurance is depleted. Provides endurance remaining in NVMe SMART logs
High Endurance Technology (HET)	Includes HET NAND silicon enhancements. Includes SSD NAND management techniques to extend SSD write endurance up to 5 drive writes per day for five years.
End-to-end data-path protection	T10 DIF (data integrity field) end-to-end data protection includes multiple levels of data-path protection.
Enhanced power-loss data protection	Energy storage components complete buffered writes to the persistent flash storage in case of a sudden power loss.
Power loss protection capacitor self-test	Supports testing of the power loss capacitor. Power is monitored using SMART (Self-Monitoring, Analysis, and Reporting Technology) attribute critical warning.
Out-of-Band Management (SMBUS)	Managed through the SMBUS. Provides out-of-band management by means of SMBUS interface. This requires 3.3V auxiliary voltage. SMBUS access includes the VPD page and temperature sensor.
Hot-Plug Support	Supports PCIe presence detect and link-up detect. Device advanced power loss protection provides robust data integrity. During IOs, the storage drive integrated monitoring enables the integrity of already committed data on the media and commits acknowledged writes to the media.
Management utilities	Refer to “Server Management Tools” in <i>Oracle Flash Accelerator F640 PCIe Card v2 and Oracle 6.4 TB NVMe SSD v2 Product Notes</i> "Management Utilities" in <i>Oracle 6.4 TB NVMe SSD v2 Product Notes</i> . For more information about management utilities, refer to the server documentation.

### Related Information

- “Oracle 6.4 TB NVMe SSD v2 Overview” on page 11
- “Oracle 6.4 TB NVMe SSD v2 Product Notes” in *Oracle Flash Accelerator F640 PCIe Card v2 and Oracle 6.4 TB NVMe SSD v2 Product Notes*.

## Usage Information

Oracle 6.4 TB NVMe SSD v2s operate and are stored in an environment defined by the parameters and specifications in the following table.

Specification	Value
Operating temperature	<ul style="list-style-type: none"> <li>■ 0 to 35°C ambient, 0 to 70°C case with specified airflow</li> <li>■ Operational environment: 5°C to 35°C (dry bulb)</li> </ul>
Non-operating temperature	Storage and transit environment: -55°C to 95°C (dry bulb)
Temperature monitoring	<p>Temperature monitoring in-band and by way of SMBUS</p> <p>See <a href="#">“Troubleshooting Oracle 6.4 TB NVMe SSD v2 Cooling” on page 39</a> for more information on thermal throttling.</p>
Thermal sensors	<p>Thermal sensors on the storage drives monitor flash memory modules</p> <p>See illustration in <a href="#">“Troubleshooting Oracle 6.4 TB NVMe SSD v2 Cooling” on page 39</a> for thermal sensor locations.</p>
Dry bulb temperature	Maximum dry bulb temperature is derated by 3.3°C per 1000 m above 500 m
Altitude (Simulated)	<ul style="list-style-type: none"> <li>■ Operating: -1,000 to 10,000 ft</li> <li>■ Non-operating: -1,000 to 40,000 ft</li> </ul>
Relative humidity range	<ul style="list-style-type: none"> <li>■ Operational environment: 8% to 80% noncondensing</li> <li>■ Storage and transit environment: 5% to 95% noncondensing</li> <li>■ Non-operating: -20°C to 75°C noncondensing</li> </ul>
Airflow requirement	More than 450 LFM (linear feet/minute) at 25/35°C, airflow towards the connector
Temperature Sensor	<p>Internal temperature sensor with an accuracy of +/-2°C over a range of -10°C to +85°C.</p> <p>Internal temperature sensor can be monitored using NVMe Health Log.</p> <p>The sensor has an accuracy of +/- 3°C over a range of -20°C to 125°C. SMBUS temperature sensor is not reported in NVMe Health Log.</p> <p>Drive provides out-of-band access to temperature by means of SMBUS.</p>

**Note** - For specific site planning guidelines and best practices, refer to the server documentation and product notes for your server. Refer to the system site planning guide, if available.

## Related Information

- [“Oracle 6.4 TB NVMe SSD v2 Overview” on page 11](#)
- [“Oracle 6.4 TB NVMe SSD v2 Service Overview” on page 33](#)

## Drive Capacity and Performance

Oracle 6.4 TB NVMe SSD v2 capacity, performance, and reliability specifications are listed in the following table.

Specification	Value
Capacity	<ul style="list-style-type: none"> <li>■ Usable capacity 6.4 TB</li> <li>■ Unformatted capacity (total user addressable sectors in LBA mode) 12,502,446,768</li> </ul>
Performance <sup>†‡</sup>	<p>Consistently high IOPS and throughput</p> <ul style="list-style-type: none"> <li>■ Sequential read speeds of up to 3.2 GB/s IOPS for 128KB Block Size, QD (Queue Depth) 256</li> <li>■ Sequential write speeds of up to 3.0 GB/s IOPS for 128KB Block Size, QD256</li> <li>■ Random read speeds of up to 694,000 IOPS for 4KB Block Size, QD256</li> <li>■ Random write speeds of up to 274,000 IOPS for 4KB Block Size, QD256</li> </ul>
Latency	<ul style="list-style-type: none"> <li>■ Sequential Latency (typical) Read/Write: 7/9 µseconds</li> <li>■ Random Latency (typical) Read/Write: 79/34 µseconds</li> <li>■ Power On to Ready Latency (typical): 2 seconds</li> <li>■ Less than 18 µsec for sequential access to the SSD.</li> </ul>
Uncorrectable Bit Error Rate (UBER)	< 1 sector per 10 <sup>17</sup> bits read *
Data Retention	Three months power-off retention once storage drive reaches rated write endurance at 40°C. The time period for retaining data in the NAND at maximum rated endurance.
Endurance Rating	<ul style="list-style-type: none"> <li>■ Up to 34.7 PBW (petabytes written) *</li> <li>■ 2.92 Drive Writes/day (JESD219 workload) <sup>5</sup></li> </ul>
Mean Time Between Failures (MTBF)	2 million hours. <sup>6</sup>

<sup>†</sup>Performance values vary by capacity and form factor.

<sup>‡</sup>Performance specifications apply to both compressible and incompressible data.

\*Uncorrectable bit error rate will not exceed one sector in the specified number of bits read. In the unlikely event of a non-recoverable read error, the storage drive will report it as a read failure to the host; the sector in error is considered corrupt and is not returned to the host.

<sup>\*</sup>Endurance rating verification is defined to establish UBER <1E-16 at 60% upper confidence limit.

<sup>5</sup>The number of drive writes is such that the storage drive meets the requirements according to the JESD219 standard.

<sup>6</sup>Mean Time Between Failures is estimated based on Telcordia methodology and demonstrated through Reliability Demonstration Test (RDT).

## Related Information

- [“Oracle 6.4 TB NVMe SSD v2 Overview” on page 11](#)
- [“Servicing Oracle 6.4 TB NVMe SSD v2s” on page 33](#)

## Electrical Specifications

Oracle 6.4 TB NVMe SSD v2 electrical specifications are listed in the following table.

Specification	Value
Power feeds	<ul style="list-style-type: none"> <li>■ 3.3V and 12V Supply Rail</li> <li>■ 3.3Vaux for SMBUS</li> </ul>
Power consumption	<ul style="list-style-type: none"> <li>■ Active Write - Average = 22W</li> <li>■ Active Read - Average = 10W</li> <li>■ Idle = 4W</li> <li>■ Active/Idle (typical): Up to 25W/4W (typical)</li> </ul>
Enhanced power-loss data protection	For data protection, Oracle 6.4 TB NVMe SSD v2 is designed with energy storage components to complete buffered writes to the persistent flash storage in case of a sudden power loss. These energy storage components are designed for the life of the drives and do not require periodic maintenance.
Power Latency	Oracle 6.4 TB NVMe SSD v2s support NVMe specifications for RTD3 Resume Latency and RTD3 Entry Latency. RTD3R Resume latency allows 12 seconds of margin for devices to safely start before main power is applied to the device controller. RTD3E Entry latency allows 10 seconds of margin for active devices to safely shutdown before main power is removed from the device controller.

Oracle 6.4 TB NVMe SSD v2 receives electrical power from the PCI Express +12 VDC and +3.3 VDC power rails as listed in the following table.

Specification	12 V Operating Characteristics	3.3 V aux Operating Characteristics
Operating voltage range	12 V (+10%/-20%)	3.3 V (+-9%)
Rise time (max/min)	50ms/1ms	50ms/1ms
Fall time (max/min)	5s/1ms	5s/1ms
Noise level	1000 mV pp at 10 Hz – 100 KHz	300 mV pp at 10 Hz – 100 KHz
	100 mV pp at 100 KHz – 20 MHz	50 mV pp at 100 KHz – 20 MHz
Minimum off time	3s	3s
Inrush current (typical peak)	1.5 A	1.5 A
Maximum average current	2.45 A	1 mA

## Related Information

- [“Oracle 6.4 TB NVMe SSD v2 Overview” on page 11](#)
- [“Oracle 6.4 TB NVMe SSD v2 Service Overview” on page 33](#)

## Physical Dimensions

The following diagram shows Oracle 6.4 TB NVMe SSD v2 physical dimensions.

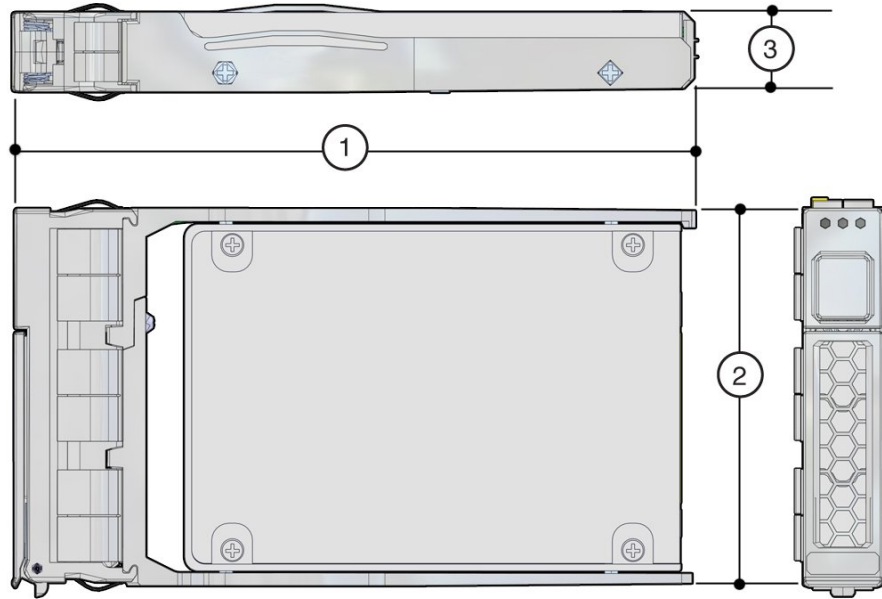

Height (3)	Width (2)	Depth (1)	Weight
0.59 in.	2.75 in.	3.955 in.	4.4 oz
15.0 +/-0.5 mm	69.85 +/- 0.25 mm	100.45 mm maximum	125 g maximum

### Related Information

- [“Oracle 6.4 TB NVMe SSD v2 Overview” on page 11](#)

# Preparing Oracle 6.4 TB NVMe SSD v2 for Installation

---

This section provides information about preparing an Oracle 6.4 TB NVMe SSD v2 for installation.

Description	Links
Prepare to install the SSD.	<a href="#">“Prepare for Installation” on page 21</a>
Gather the required tools.	<a href="#">“Required Tools” on page 22</a>
Unpack the shipping kit.	<a href="#">“Ship Kit Contents” on page 22</a>
Review safety information.	<a href="#">“Observing Safety Precautions” on page 24</a>
Review electrostatic discharge (ESD) safety measures.	<a href="#">“ESD Safety Measures” on page 25</a>
Review 6.4 TB NVMe SSD v2 optimization guidelines.	<a href="#">“Oracle 6.4 TB NVMe SSD v2 Optimization Guidelines” on page 26</a>
Update your system to the latest software release.	<a href="#">“Update Your System to the Latest Software Release” on page 27</a>

---

**Note** - To install Oracle 6.4 TB NVMe SSD v2s in a specific server, refer to your server documentation. For information about restrictions and use of Oracle 6.4 TB NVMe SSD v2s on your server, see the most recent version of the server product notes.

---

## ▼ Prepare for Installation

1. **Gather the required tools.**  
See [“Required Tools” on page 22](#).
2. **Unpack the shipping kit that includes the storage drive.**
  - a. **Unpack the storage drive in a static-free environment.**

See [“Ship Kit Contents” on page 22](#).

- b. Remove the storage drive from its packaging, and place the drive on an antistatic mat, using good antistatic grounding procedures.**

See [“ESD Safety Measures” on page 25](#).

- 3. Carefully inspect the storage drive for shipment damage.**

If you notice any damage, contact Oracle Technical Support or your reseller support representative. See [“Technical Support” on page 40](#).

## Required Tools

You will need the following tools for most service operations:

- Antistatic wrist strap
- Antistatic mat

### Related Information

- [“ESD Safety Measures” on page 25](#)

## Ship Kit Contents

The Oracle 6.4 TB NVMe SSD v2 ship kit contains the components shown in the following illustration.

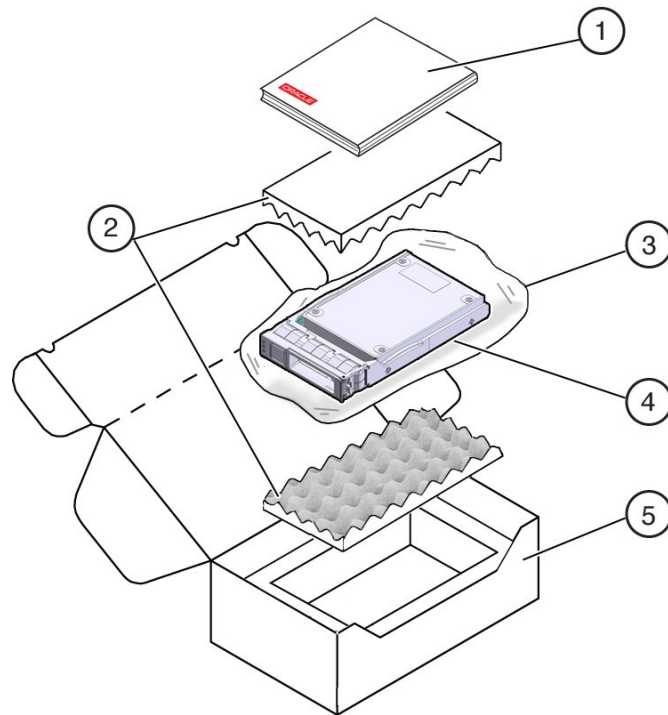

Call Out	Description
1	Documentation
2	Foam
3	Antistatic bag
4	Oracle 6.4 TB NVMe SSD v2
5	Packaging

## Related Information

- [“Oracle 6.4 TB NVMe SSD v2 Overview” on page 11](#)

## Observing Safety Precautions

This section contains safety information about preventing equipment damage and personnel injury.

- [“General Safety Information” on page 24](#)
- [“Safety Symbols” on page 24](#)
- [“ESD Safety Measures” on page 25](#)
- [“Perform ESD Prevention Measures” on page 25](#)

## General Safety Information

For your protection, observe the following safety precautions when setting up your equipment:

- Follow all cautions and instructions marked on the equipment.
- Follow all cautions and instructions described in the documentation shipped with your system and described in the server safety information.
- Follow the electrostatic discharge safety practices as described in this section.

## Safety Symbols

Note the meanings of the following symbols that might appear in this document.



---

**Caution** - There is a risk of personal injury or equipment damage. To avoid personal injury and equipment damage, follow the instructions.

---



---

**Caution** - Hot surface. Avoid contact. Surfaces are hot and might cause personal injury if touched.

---



---

**Caution** - Hazardous voltages are present. To reduce the risk of electric shock and danger to personal health, follow the instructions.

---

## ESD Safety Measures

Circuit boards and drives contain electronic components that are extremely sensitive to static electricity. Ordinary amounts of static electricity from clothing or the work environment can destroy the components located on these boards. Electrostatic discharge (ESD) sensitive devices, such as the storage drives, require special handling.

- Place ESD-sensitive components, such as printed circuit boards and storage drives on an antistatic mat (not provided).
- Wear an antistatic wrist strap when handling ESD-sensitive components.



---

**Caution** - Possible component damage. Do not touch components along connector edges.

---

### ▼ Perform ESD Prevention Measures

1. **Prepare an antistatic surface to set parts on during the removal, installation, or replacement processes.**

Place ESD-sensitive components such as the storage drives on an antistatic mat. The following items can be used as an antistatic mat:

- Antistatic bag used to wrap a replacement part
- ESD mat
- A disposable ESD mat (shipped with some replacement parts or optional system components)

2. **Attach an antistatic wrist strap.**

When servicing or removing server components, attach an antistatic strap to your wrist and then to a metal area on the chassis.

#### Related Information

- [“ESD Safety Measures” on page 25](#)
- [“Oracle 6.4 TB NVMe SSD v2 Service Overview” on page 33](#)

## Oracle 6.4 TB NVMe SSD v2 Optimization Guidelines

To optimize performance, observe the following guidelines when setting up Oracle 6.4 TB NVMe SSD v2s in a server.

- Block size can be configured through a server operating system or file system and is set to a default size with Oracle databases.
- Oracle 6.4 TB NVMe SSD v2s are designed to provide best performance for data transfers that are multiples of 4k size and using addresses that are 4k aligned. Partitions should be aligned to start on 4k boundaries.
- The ZFS file system might require manual alignment. Oracle 6.4 TB NVMe SSD v2 has a maximum transfer size of 128k. IO requests for larger transfer sizes are broken into transfer sizes of 128k or smaller. For optimal performance, transfer sizes should be limited to 128k to avoid additional overhead associated with breaking into smaller transfer sizes.
- Oracle 6.4 TB NVMe SSD v2 should be formatted using a label of type EFI (`format -e` command).

Ensure that when the EFI label is created by ZFS, the default start sector is 256, which aligns S1 with 128k (if the block size is 512). The vtoc label default cylinder size is 50176 (224\*224) blocks. If the block size is 512, the default Oracle Solaris operating system partition aligns with 512k. For example:  $50176 * 512 = 49 * 512 * 1024$ .

Specify and ensure 4k alignment: The default start sector of 34 for EFI labels is not a 4k aligned value. Use the partition subcommand of the Oracle Solaris `format` command to change the start sector to 256, or any other 128k aligned value. Note that there are 512B per sector.

- The ZFS file system automatically aligns partitions to start on 8k boundaries when a full disk is allocated to ZFS (recommended). If you allocate individual EFI partitions to a ZFS pool, ensure that the partition is 4k-aligned.
- For highest performance, ensure that the system meets the physical, environmental, and electrical specifications listed in “Specifications” on page 14.

### Related Information

- Tuning ZFS When Using Flash Storage [https://docs.oracle.com/cd/E53394\\_01/html/E54818/chapterzfs-flash.html](https://docs.oracle.com/cd/E53394_01/html/E54818/chapterzfs-flash.html)

## Drive Volume Management

A volume manager can present multiple SSD devices as one larger volume. Use the Automatic Storage Management (ASM) volume manager or other volume manager to concatenate multiple flash memory domains. For example, a volume manager can be used to concatenate four 6.4 TB domains into a single 25.2 TB volume.

For more information about ASM, refer to "Introduction to Automatic Storage Management (ASM)" in the *Oracle Database Administrator's Guide, Release 18c*.

## ▼ Update Your System to the Latest Software Release

It is highly recommended that you update your system to the latest software release before you use the system. Software releases often include bug fixes, and updating ensures that your server software is compatible with the latest server firmware and other component firmware and software.

---

**Note** - System firmware update releases include Oracle 6.4 TB NVMe SSD v2 component firmware updates. When system firmware updates, as described in the server documentation, Oracle 6.4 TB NVMe SSD v2 firmware automatically updates.

---

1. **Check the Oracle 6.4 TB NVMe SSD v2 Product Notes for the latest firmware requirements.**

The most up-to-date Product Notes document is available at: <https://www.oracle.com/goto/oracleflash640/docs>

2. **Download and install any firmware updates required to support the SSD, host bus adapter (HBA), drive backplane, system BIOS, or OBP/system (SPARC) firmware.**

You can download the latest firmware and software updates from My Oracle Support at <https://support.oracle.com>.

For information about downloading Oracle 6.4 TB NVMe SSD v2 firmware and software from My Oracle Support, refer to "Accessing Software Updates and Firmware Downloads" in *Oracle 6.4 TB NVMe SSD v2 Product Notes*.

Refer also to "Getting Server Firmware and Software Updates" in the server installation guide documentation.

### **Related Information**

- “Download the Device Software Package” in *Oracle 6.4 TB NVMe SSD v2 Product Notes*
- “Update the NVMe Storage Drive Firmware” in *Oracle 6.4 TB NVMe SSD v2 Product Notes*
- “Verify Oracle 6.4 TB NVMe SSD v2 Operation” in *Oracle 6.4 TB NVMe SSD v2 Product Notes*
- [“Oracle 6.4 TB NVMe SSD v2 Overview” on page 11](#)
- [“Oracle 6.4 TB NVMe SSD v2 Service Overview” on page 33](#)

# Installing Oracle 6.4 TB NVMe SSD v2s

---

This section contains information about installing Oracle 6.4 TB NVMe SSD v2s into a server drive bay.

Description	Links
Review installation tasks and performance tuning information before installing the SSD.	<a href="#">“Installation Overview” on page 29</a>
Install a new SSD into a server.	<a href="#">“Install a New Oracle 6.4 TB NVMe SSD v2 (CRU)” on page 30</a>

## Installation Overview

Read this overview information section before installing Oracle 6.4 TB NVMe SSD v2 into a server.

For detailed instructions on how to install your 6.4 TB NVMe SSD, refer to your server service documentation or drive enclosure documentation. Refer to the server service manual for additional installation information.

The drive bracket assembly should not be disassembled for any reason by the user.

## Oracle 6.4 TB NVMe SSD v2 Installation Tasks

To install an Oracle 6.4 TB NVMe SSD v2 into a supported server system, refer to the steps described in the following table.

Steps	Task	See
1.	Prepare the SSD for installation. Carefully unpack the SSD. Inspect the SSD for damage. Follow ESD precautions.	<a href="#">“Preparing Oracle 6.4 TB NVMe SSD v2 for Installation” on page 21</a>
2.	Insert the SSD in an available drive slot.	<a href="#">“Install a New Oracle 6.4 TB NVMe SSD v2 (CRU)” on page 30</a>

### Related Information

- [“Product Overview” on page 11](#)
- [“Oracle 6.4 TB NVMe SSD v2 Service Overview” on page 33](#)

## ▼ Install a New Oracle 6.4 TB NVMe SSD v2 (CRU)

To install a new Oracle 6.4 TB NVMe SSD v2 (2.5-inch small form factor, U.2) into a supported server:

1. **Back up your data, as required, before changing your server configuration.**
2. **Identify a supported and available slot in the server.**

Refer to the server service manual for drive locations on the server.

Refer to “Supported Hardware and Software” in *Oracle 6.4 TB NVMe SSD v2 Product Notes*.

---

**Note** - While using Oracle 6.4 TB NVMe SSD v2 2.5-inch small form factor drive, locate a server slot on the server panel labeled NVMe (with SFF-8639 disk backplane and connector) that is capable of supporting Oracle 6.4 TB NVMe SSD v2. Your server chassis must contain NVMe equipment, including Oracle NVMe Switch Controller Cards and cables. Refer to the server service manual for detailed NVMe SSD installation instructions.

---

3. **Locate the storage drive filler panel in the server.**

If the optional NVMe storage drives are installed in the server front or back panel, they are labeled NVMe0, NVMe1, NVMe2, NVMe3 and so on. However, the server operating system assigns the installed storage drives different names. For the corresponding names assigned by the operating system, refer to the server service manual.

4. **Prepare the SSD for installation.**

See [“Preparing Oracle 6.4 TB NVMe SSD v2 for Installation” on page 21](#).

- 5. Record the serial number of the NVMe SSD and NVMe slot number where the SSD will be installed.**

This drive serial number (WWN) and server slot information can be used at a later time for identifying drives from the console. Refer to the server service manual.

- 6. If necessary, remove the drive filler panel.**

Remove the blank storage drive filler panel on the server chassis that aligns with the empty NVMe drive slot.

For instructions on how to remove drive filler panels, refer to the server service manual.

- 7. Slide the Oracle 6.4 TB NVMe SSD v2 into the supported NVMe slot until the drive is fully seated.**

The following figure shows how to insert the SSD in a server NVMe slot.

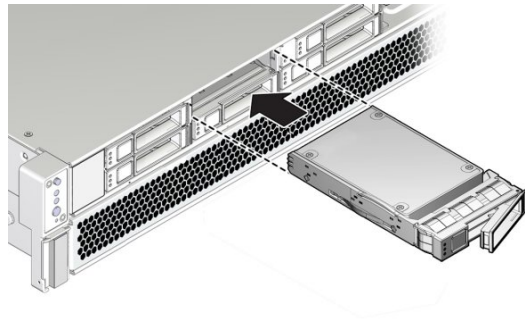

- 8. Close the drive latch to lock the drive in place.**

- 9. Configure the server for the new SSD.**

Refer to the server documentation library for detailed instructions. Refer to the server administration guide or the operating system documentation for detailed NVMe SSD configuration instructions.

- a. If applicable, perform any required commands for your system to install the device driver for the new SSD.**
- b. If applicable, perform any required commands for your system to recognize the new SSD.**

**c. Verify successful installation of the SSD through your server operating system.**

When the installation is complete, the Oracle 6.4 TB NVMe SSD v2 is visible to your server operating system.

**d. Configure the system to maximize flash technology.**

**Related Information**

- [“Product Overview” on page 11](#)
- [“Oracle 6.4 TB NVMe SSD v2 Service Overview” on page 33](#)

## Servicing Oracle 6.4 TB NVMe SSD v2s

---

This section provides service information for Oracle 6.4 TB NVMe SSD v2.

Description	Links
Review service task and troubleshooting information.	<a href="#">“Oracle 6.4 TB NVMe SSD v2 Service Overview” on page 33</a>
Review NVMe drive component serviceability information.	<a href="#">“Component Serviceability” on page 34</a>
Remove and replace NVMe drives.	<a href="#">“Replace an Existing Oracle 6.4 TB NVMe SSD v2 (CRU)” on page 35</a>
Troubleshoot NVMe drive thermal issues.	<a href="#">“Troubleshooting Oracle 6.4 TB NVMe SSD v2 Cooling” on page 39</a>
Contact Technical Support.	<a href="#">“Technical Support” on page 40</a>

### Oracle 6.4 TB NVMe SSD v2 Service Overview

For service, Oracle 6.4 TB NVMe SSD v2 contains updatable flash ROM for storing the BIOS and firmware, as well as NVRAM for storing nonvolatile configuration data. Use Oracle Hardware Management Pack to monitor and service the SSD. You can also use Oracle Hardware Management Pack for troubleshooting. See Server Management in [“Characteristics” on page 16](#) and refer to “Server Management Tools” in *Oracle 6.4 TB NVMe SSD v2 Product Notes*.

In addition, you can monitor Oracle 6.4 TB NVMe SSD v2 health and flash media drive life through SSD bracket status indicator LEDs. The SSD has three status indicator LEDs on the drive bracket to indicate activity, drive life, and status. See [“Status Indicators” on page 12](#).

Oracle 6.4 TB NVMe SSD v2 requires no periodic maintenance. For data protection, Oracle 6.4 TB NVMe SSD v2 is designed with energy storage components to complete buffered writes to the persistent flash storage in case of a sudden power loss. These energy storage components are designed for the life of Oracle 6.4 TB NVMe SSD v2s and do not require periodic maintenance.

Refer to the server documentation for additional service information. Late-breaking information and known issues for the server are included in the server product notes. Late-breaking information and known issues for this product are included in *Oracle 6.4 TB NVMe SSD v2 Product Notes*.

---

**Note** - Refer to the server documentation for additional NVMe storage drive service and firmware download information. Refer to the server service manual for detailed removal and replacement instructions for NVMe SSDs.

---

## Component Serviceability

The following service actions can be performed on an Oracle 6.4 TB NVMe SSD v2.

- Unmount an NVMe storage drive
- Remove an NVMe storage drive from the server
- Verify removal of an NVMe storage drive
- Install an NVMe storage drive in the server
- Power on an NVMe storage drive and attach a device driver

Refer to the server documentation for additional service information. Late-breaking information and known issues for this product are included in the “Oracle 6.4 TB NVMe SSD v2 Product Notes” in *Oracle 6.4 TB NVMe SSD v2 Product Notes*.

Components are either hot serviceable or cold serviceable. Hot-service capability allows you to safely remove this component while the server is running. Cold-service capability requires a powered off state, therefore you need to remove power from the server.

Components are designated either CRU (customer-replaceable unit) or FRU (field-replaceable unit). CRU service capability allows trained technicians and authorized field service personnel to service this component. FRU service capability allows only authorized service personnel to service this component. Oracle 6.4 TB NVMe SSD v2 is a CRU.

The following table lists the serviceability of NVMe components and directs you to replacement instructions.

Component	Serviceability	Replacement Instructions
Oracle 6.4 TB NVMe SSD v2 (and fillers)	Hot	<a href="#">“Installing Oracle 6.4 TB NVMe SSD v2s” on page 29</a>
	CRU	<a href="#">“Replace an Existing Oracle 6.4 TB NVMe SSD v2 (CRU)” on page 35</a>

Component	Serviceability	Replacement Instructions
		For instructions on safe installation and removal of SSDs, refer to the server service manual.
Oracle PCIe NVMe Switch Card	Cold FRU	For instructions on safe installation and removal of cards, refer to the server service manual.
NVMe cables	Cold FRU	For instructions on safe installation and removal of cables and connected drive backplane, refer to the server service manual.

## Related Information

- [“Product Overview” on page 11](#)
- [“Technical Support” on page 40](#)

## ▼ Replace an Existing Oracle 6.4 TB NVMe SSD v2 (CRU)

Replace an Oracle 6.4 TB NVMe SSD v2 if the drive fails or the usable drive life has been exceeded.



**Caution** - Possible component damage. Different server platforms place NVMe-capable bays in different locations. To identify a server’s NVMe-capable bay, observe that the orange silk screen on the server is labeled **NVMe** before inserting an NVMe storage drive into an NVMe-capable slot. Your server chassis must contain an NVMe-capable configuration including Oracle NVMe Switch Controller Cards and cables.



**Caution** - Possible component damage. Circuit boards and drives contain electronic components that are extremely sensitive to static electricity. Ordinary amounts of static electricity from clothing or the work environment can destroy the components located on these boards. Do not touch the components along their connector edges. These procedures require that you handle components that are sensitive to electrostatic discharge. This sensitivity can cause the components to fail. To avoid damage, ensure that you follow antistatic practices as described in [“ESD Safety Measures” on page 25](#).

The following steps provide an example procedure. Follow the server service manual instructions for replacing an NVMe storage drive.

1. **Prepare the server operating system, as required, before you remove drives.**

Follow the server service manual instructions for orderly shutdown during NVMe storage drive insertion and removal service actions.

Unmount the NVMe storage drives.

**2. Identify the physical location of the NVMe drive that you want to remove.**



---

**Caution** - Possible component damage. While using a U.2 2.5-inch 15mm form factor drive, locate a server slot on the server front panel labeled **NVMe** (with SFF-8639 disk backplane and connector) that is capable of supporting the Oracle 6.4 TB NVMe SSD v2 and that is labeled as shown in the following figure. Never insert an NVMe storage drive into a non-NVMe capable slot that supports hard disk drives only (labeled HDD).

---

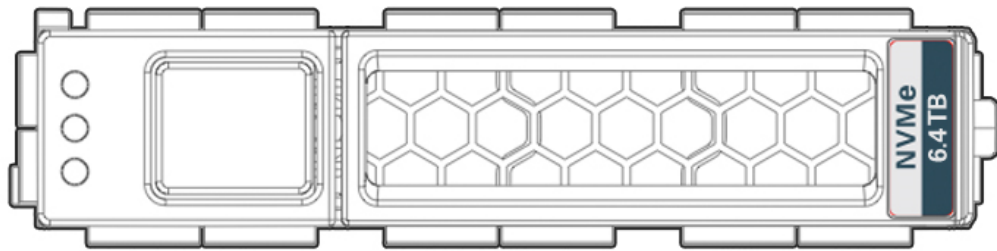

**3. Observe the status indicator LEDs on the front panel of the drive to verify which drive in the server requires replacement.**

- Verify that the blue OK to Remove status indicator LED on the NVMe storage drive is lit.
- Green (operational), amber (faulty disk), blue (SSD has been prepared for removal)
- See [“Status Indicators” on page 12](#).

**4. Remove the NVMe storage drive from the server.**

**a. On the drive that you plan to remove, push the latch release button to open the drive latch.**

Press the release lever button on the drive front panel and then tilt the lever into a fully opened position.

**b. Grasp the opened release lever and gently slide the drive toward you.**

- c. **If you are not immediately replacing the drive, insert a filler panel into the empty drive slot on the server.**

If you are not replacing the drive, install a filler panel in the empty drive slot to maintain proper airflow and perform administrative tasks to configure the server to operate without the drive.

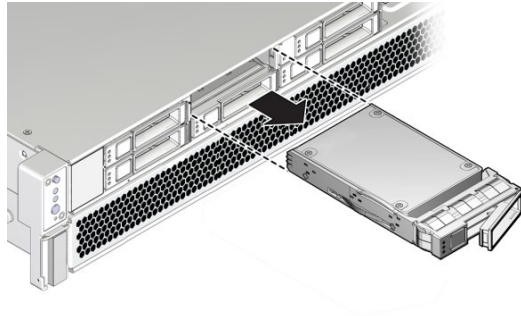

5. **Verify removal of the NVMe storage drive.**

Follow the server service manual instructions for NVMe storage drive identification.

6. **Install (or replace) the NVMe storage drive.**

The drive is physically addressed according to the slot in which it is installed. It is important to install a replacement drive in the same slot as the drive that was removed.

Refer to “Supported Servers and Operating Systems” in *Oracle 6.4 TB NVMe SSD v2 Product Notes*.

- a. **Slide the drive into the vacant slot by pressing the middle of the drive faceplate with your thumb or finger.**

Slide the drive into the slot until the drive is fully seated.

- b. **Close the drive latch to lock the drive in place.**

Using your thumb or finger, press on the middle of the drive faceplate until the release lever engages with the chassis. Close the release lever until it clicks into place and is flush with the front of the server.

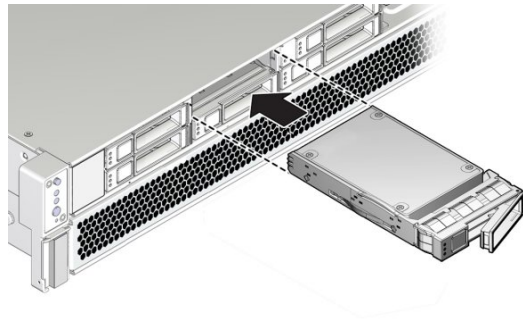

---

**Caution** - Possible component damage. While using a 2.5-inch form factor drive, locate a server slot on the server front panel labeled **NVMe** (with SFF-8639 disk backplane and connector) that is capable of supporting the Oracle 6.4 TB NVMe SSD v2. Never insert an NVMe storage drive into a non-NVMe capable hard disk drive slot (HDD).

---

**7. For hot-plug service actions, configure the NVMe storage drive and verify drive availability.**

- Follow the server service manual instructions for NVMe storage drive configuration and identification.
- Use appropriate software commands to return the system to an operational state:
  - Power on the NVMe storage drive, as required.
  - Attach a device driver, as required.
  - Re-activate mirror if manual intervention is required.
  - Re-sync mirror if manual intervention is required.

**Related Information**

- [“Product Overview” on page 11](#)
- [“Oracle 6.4 TB NVMe SSD v2 Service Overview” on page 33](#)

## Troubleshooting Oracle 6.4 TB NVMe SSD v2 Cooling

Maintaining the proper internal operating temperature of the server is crucial to the health of the server. To prevent server shutdown and damage to components, address overtemperature and hardware-related issues as soon as they occur.

Use the status indicator LEDs to determine the status of the Oracle 6.4 TB NVMe SSD v2. The LEDs provide key status information to diagnose SSD issues. See [“Status Indicators” on page 12](#).

The Oracle 6.4 TB NVMe SSD v2 is designed to provide continuous full bandwidth performance with temperatures up to 73°C. Qualified host platforms with required software updates operate with sufficient margin to the maximum temperature under worst case environments. Should the system maximum operating temperature be exceeded or a system fault occur that causes internal temperatures of the flash memory modules to rise above this limit, the SSD responds as follows:

- 73°C – Drive write throttling is engaged to reduce SSD power.
  - SSD amber status indicator LED is lit, Service Action Required.
  - Temperature warning is displayed in utility output.
- 78°C – Additional drive write throttling is engaged.
  - SSD amber status indicator LED is lit, Service Action Required.
  - Critical temperature status is displayed in utility output.



---

**Caution** - Sustained critical temperatures might cause data loss.

---

Refer to the server documentation for additional service information.

The following image shows the Oracle 6.4 TB NVMe SSD v2 temperature sensor location [1] (inside enclosure).

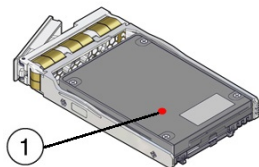

### Related Information

- “Status Indicators” on page 12
- “Product Overview” on page 11
- “Oracle 6.4 TB NVMe SSD v2 Service Overview” on page 33
- “Technical Support” on page 40

## Technical Support

For technical assistance installing, configuring, or running Oracle 6.4 TB NVMe SSD v2s, contact Oracle Technical Support.

- Go to <https://www.oracle.com/support/>. Please have your server Customer Support ID (CSI) ready. Sign in to My Oracle Support to open a service request. You must have purchased support to access My Oracle Support.
- You can also call Oracle support, using the appropriate number from Oracle Global Customer Support Contacts Directory.

### Related Information

- “Supported Hardware and Software” in *Oracle 6.4 TB NVMe SSD v2 Product Notes*

# Index

---

## A

- about the drive, 11
- activity, 12
- antistatic, 25
- automatic storage management, 27

## C

- capabilities, 14
- capacity, 16, 17
- characteristics, 16
- cold service, 34
- compatibility, 16
- components, 15, 34
- controller, 15
- critical temperature, 39
- customer-replaceable unit (CRU), 34

## D

- description, 11
- device name, 15
- dimensions, 19
- drive
  - capacity, 17
  - performance, 17
  - reliability, 17
- drive installation, 29
- drive volume management, 27
- drive write throttling, 39

## E

- EFI label, 26
- electrical specifications, 14, 18
- electrostatic discharge (ESD)
  - antistatic wrist strap, 25
  - preventing using an antistatic mat, 25
  - safety measures, 25
- environmental specifications, 14, 16

## F

- feedback, 9
- field-replaceable unit (FRU), 34
- firmware, 27, 33

## H

- hardware, 16
- host system, 27
- hot service, 34

## I

- indicators, 12, 39
- insertion, 35
- inspecting, 21
- install an SSD, 30
- installation, 29
  - overview, 29
  - task map, 29
- IOPS, 11

## L

LEDs, 12, 39  
life monitoring, 16

## M

maintenance, 33  
manufacturing name, 15

## N

name  
    device, 15  
    manufacturing, 15  
NAND, 15  
new drive installation, 30  
NVMe, 11  
NVMe connecting cable, 13

## O

operating systems, 16  
optimization, 26  
Oracle 6.4 TB NVMe storage drive, 11  
Oracle PCIe NVMe Switch Card, 13, 34  
overview, 11

## P

PCIe, 15  
performance, 17  
physical dimensions, 19  
physical specifications, 14  
precautions, 24  
prepare for installation, 21  
preparing drive for installation, 21  
prevention measures, ESD, 25  
product notes, 9  
product overview, 11  
product specification, 14  
product specifications, 15

## R

reliability specifications, 14, 17  
removal, 35  
replacement, 35  
replacement instructions, 34

## S

safety  
    ESD, 25  
    information, 24  
    precautions, 24  
    symbols, 24  
service information, 33  
service overview, 33  
serviceability, 34  
servicing drives, 33  
ship kit, 22  
SMART logs, 16  
software, 16  
specifications, 14  
SSD description, 11  
status, 12, 39  
storage drives, indicators, 12  
style, form factor, 15  
symbols, 24

## T

task map, 29  
    installation, 29  
technical support, 40  
temperature sensor, 39  
tools required for service, 22  
troubleshooting, 33, 39

## U

unpacking, 21  
updating firmware, 27  
utilities, 16

**Z**

ZFS file system, 26

