

# **OFS Customer Screening**

## **Administration and Configuration Guide**

**Release 8.0.7.0.0**

**July 2019**

**F16453-01**



## OFS Customer Screening Administration and Configuration Guide

Copyright © 2020 Oracle and/or its affiliates. All rights reserved.

This software and related documentation are provided under a license agreement containing restrictions on use and disclosure and are protected by intellectual property laws. Except as expressly permitted in your license agreement or allowed by law, you may not use, copy, reproduce, translate, broadcast, modify, license, transmit, distribute, exhibit, perform, publish, or display any part, in any form, or by any means. Reverse engineering, disassembly, or decompilation of this software, unless required by law for interoperability, is prohibited.

The information contained herein is subject to change without notice and is not warranted to be error-free. If you find any errors, please report them to us in writing.

If this is software or related documentation that is delivered to the U.S. Government or anyone licensing it on behalf of the U.S. Government, then the following notice is applicable:

U.S. GOVERNMENT END USERS: Oracle programs, including any operating system, integrated software, any programs installed on the hardware, and/or documentation, delivered to U.S. Government end users are “commercial computer software” pursuant to the applicable Federal Acquisition Regulation and agency-specific supplemental regulations. As such, use, duplication, disclosure, modification, and adaptation of the programs, including any operating system, integrated software, any programs installed on the hardware, and/or documentation, shall be subject to license terms and license restrictions applicable to the programs. No other rights are granted to the U.S. Government.

This software or hardware is developed for general use in a variety of information management applications. It is not developed or intended for use in any inherently dangerous applications, including applications that may create a risk of personal injury. If you use this software or hardware in dangerous applications, then you shall be responsible to take all appropriate fail-safe, backup, redundancy, and other measures to ensure its safe use. Oracle Corporation and its affiliates disclaim any liability for any damages caused by use of this software or hardware in dangerous applications.

Oracle and Java are registered trademarks of Oracle and/or its affiliates. Other names may be trademarks of their respective owners.

Intel and Intel Xeon are trademarks or registered trademarks of Intel Corporation. All SPARC trademarks are used under license and are trademarks or registered trademarks of SPARC International, Inc. AMD, Opteron, the AMD logo, and the AMD Opteron logo are trademarks or registered trademarks of Advanced Micro Devices. UNIX is a registered trademark of The Open Group.

This software or hardware and documentation may provide access to or information about content, products, and services from third parties. Oracle Corporation and its affiliates are not responsible for and expressly disclaim all warranties of any kind with respect to third-party content, products, and services unless otherwise set forth in an applicable agreement between you and Oracle. Oracle Corporation and its affiliates will not be responsible for any loss, costs, or damages incurred due to your access to or use of third-party content, products, or services, except as set forth in an applicable agreement between you and Oracle.

For information on third party licenses, click [here](#).

# Document Control

Version Number	Revision Date	Change Log
8.0.7.0.25	April 2020	<ul style="list-style-type: none"> <li>Updated the URL for HM Treasury in the Pre-Configured Watch List Information Appendix.</li> <li>Added a section for configuring the shell script file for Accuity in the Pre-Configured Watch List Information Appendix.</li> </ul>
8.0.7.0.0	August 2019	<ul style="list-style-type: none"> <li>Updated EDQ port number to JMX port number in the Scheduling the Customer Screening Run Job section.</li> <li>Added a table to signify the order in which the jobs must be run in the Scheduling the Customer Screening Run Job section.</li> </ul>
8.0.7.0.0	July 2019	<ul style="list-style-type: none"> <li>Added the configurations for Delta updates in the <i>General Configurations</i> chapter.</li> <li>Updated the <i>Real-Time Screening</i> section in the <i>Preparing Customer and External Entity Data for Screening</i> chapter.</li> <li>Updated the Dow Jones Watch list section in the <i>Screening Non-Latin Character Sets</i> chapter.</li> <li>Added new staging and customer table names for alias in the Data Flow section.</li> <li>Added a note which mentions the users who must be mapped to the Realtime Access Group in the <i>Real-Time Screening</i> section.</li> <li>Updated the <code>.properties</code> files in the <i>Configuring Watch List Management, Customer Screening, External Entity Screening and Real-Time Screening</i> chapter.</li> </ul>
8.0.7.0.0	May 2019	Created the 807 guide.

# Table of Contents

<b>1</b>	<b>Introduction .....</b>	<b>7</b>
1.1	Architecture Overview .....	7
1.2	Data Flow .....	8
<b>2</b>	<b>General Configurations .....</b>	<b>9</b>
2.1	Configuring Watch List Management, Customer Screening, External Entity Screening and Real-Time Screening.....	9
2.1.1	<i>Preparing Watch List Data</i> .....	10
2.1.2	<i>Private Watch List Set Up</i> .....	12
2.1.3	<i>Showing Watch List Staged Data/Snapshots in the Server Console UI</i> .....	13
2.1.4	<i>Configuring Match Rules</i> .....	13
2.1.5	<i>Real-Time and Batch Screening Set Up</i> .....	14
2.1.6	<i>Outputting Relationships Data to Files</i> .....	14
2.2	Configurations for Delta Updates .....	14
2.2.1	<i>General Configurations</i> .....	15
2.2.2	<i>Running the Full Watchlist</i> .....	15
2.2.3	<i>Running the Delta Updates</i> .....	16
2.2.4	<i>Additional Configurations</i> .....	16
2.3	Filtering Watch List Data .....	17
2.3.1	<i>Enabling Watch List Filtering</i> .....	17
2.3.2	<i>Configuring Watch List Filtering</i> .....	17
2.3.3	<i>Primary and Secondary Filtering, and Linked Records</i> .....	19
2.3.4	<i>Setting Multiple Values for Primary and Secondary Filters</i> .....	19
2.3.5	<i>Screening All Data Using Sanctions Rules</i> .....	21
2.4	Configuring Enterprise Case Management (ECM) .....	21
2.4.1	<i>Case Class in ECM</i> .....	21
2.4.2	<i>Case Types under Case Class</i> .....	22
2.4.3	<i>Creating Workflows for Case Types</i> .....	22
2.4.4	<i>Searching Customer Screening related Cases in Oracle Financial Services ECM</i> .....	23
2.4.5	<i>Taking Action on Customer Screening related Cases in Oracle Financial Services ECM</i> .....	23
2.4.6	<i>Match Persistence and Flag Keys</i> .....	24

2.5	Scheduling the Customer Screening Run Job .....	24
2.5.1	<i>Loading Data into the CUST tables</i> .....	27
2.5.2	<i>Creating and Running Parallel Batches</i> .....	27
2.6	Risk Scoring .....	29
2.6.1	<i>Adjusting the Risk Scoring Mechanism</i> .....	29
2.6.2	<i>Adjusting the Risk Element Scores</i> .....	30
2.7	Configurations for GDPR .....	33
<b>3</b>	<b>Preparing Customer and External Entity Data for Screening .....</b>	<b>34</b>
3.1	Real-Time Screening .....	34
3.2	Screening Watch list Records in Real Time .....	35
3.3	Configuring the EDQ URL .....	36
3.4	Batch Screening from Financial Services Crime Model (FCDM) .....	37
3.4.1	<i>Staging Database Connection Details</i> .....	37
3.5	FCDM System Name .....	38
3.6	FCDM Data Preparation .....	38
3.6.1	<i>Analyzing Customer Data and External Entity Data Quality</i> .....	39
3.6.2	<i>ETL Database Connection Details</i> .....	40
3.6.3	<i>Batch Screening Job</i> .....	41
3.6.4	<i>Real-Time Screening Job</i> .....	41
<b>4</b>	<b>Workflow Diagrams .....</b>	<b>42</b>
4.1	SAN and PRB Workflow .....	42
4.2	PEP and EDD Workflow .....	42
<b>5</b>	<b>Appendix A: Screening Non-Latin Character Sets .....</b>	<b>43</b>
<b>6</b>	<b>Appendix B: Risk Scoring Reference Data .....</b>	<b>45</b>
6.1	General .....	45
6.2	Country Prohibitions .....	45
6.3	Dow Jones Watchlist .....	45
6.4	Dow Jones Anti-Corruption List .....	45
6.5	EU Reference Data .....	45
6.6	HM Treasury Reference Data .....	46
6.7	OFAC Reference Data .....	46

6.8	UN Reference Data .....	46
6.9	World-Check Reference Data .....	46
6.10	Accuity Reference Data .....	46
6.11	Risk Element Weightings .....	46
<b>7</b>	<b>Appendix C: Pre-Configured Watch List Information .....</b>	<b>47</b>
7.1	HM Treasury Reference Data .....	47
7.2	OFAC Reference Data .....	47
7.3	EU Reference Data .....	48
7.4	UN Reference Data .....	48
7.5	World-Check Reference Data .....	48
7.6	Dow Jones Watchlist Reference Data.....	49
7.7	Dow Jones Anti-Corruption List Reference Data .....	50
7.8	Accuity Reference Data .....	52
7.8.1	<i>Configuring the .sh File</i> .....	53

# 1 Introduction

This document details the steps required to configure the Oracle Financial Services Customer Screening application based on your requirements after the application has been installed.

For information on the installation process, refer to the [Oracle Financial Services Sanctions Pack Installation and Configuration Guide](#).

These instructions assume the reader has a good understanding of Enterprise Case Management (ECM), Financial Crime Data Model (FCDM), Oracle Enterprise Data Quality (OEDQ) and knowledge of Sanctions, PEP, EDD and country prohibition screening requirements.

Oracle Financial Services Customer Screening consists of:

- Customer or External Entity Data in FCDM
- Real-time Screening User Interface and REST web service
- OEDQ functionality for managing watch list data and screening working data
- Enterprise Case Management for Batch Scheduling, Case Types and Workflows

The standard Customer Screening implementation is customized for specific data, screening, watch list and operational requirements.

## 1.1 Architecture Overview

The diagram above gives a high level overview of the Oracle Financial Services Customer Screening architecture.

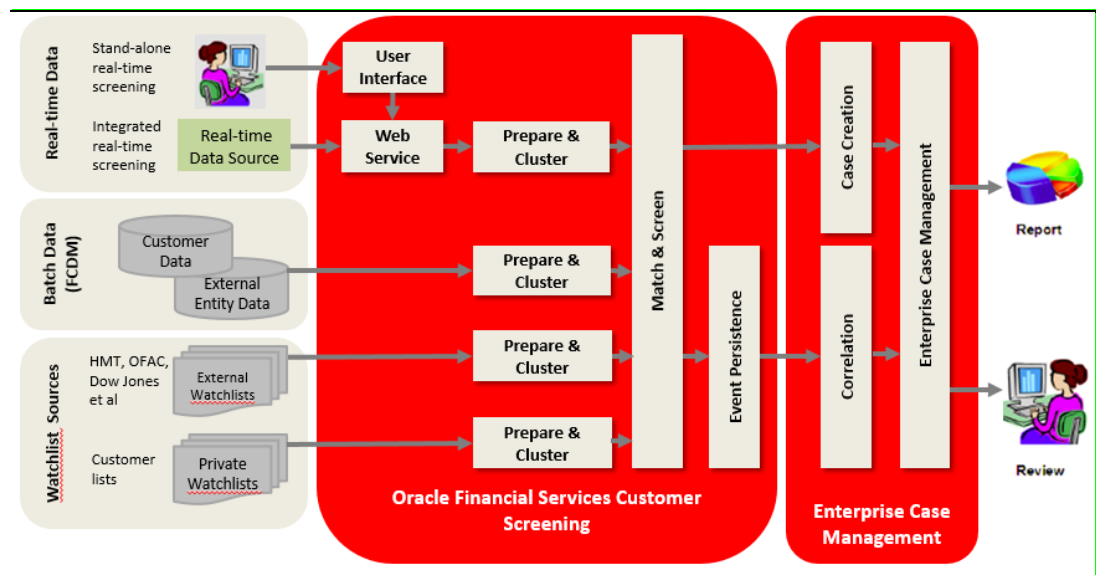

## 1.2 Data Flow

The diagram below describes the data flow from Customer Screening Enterprise Case Management (ECM):

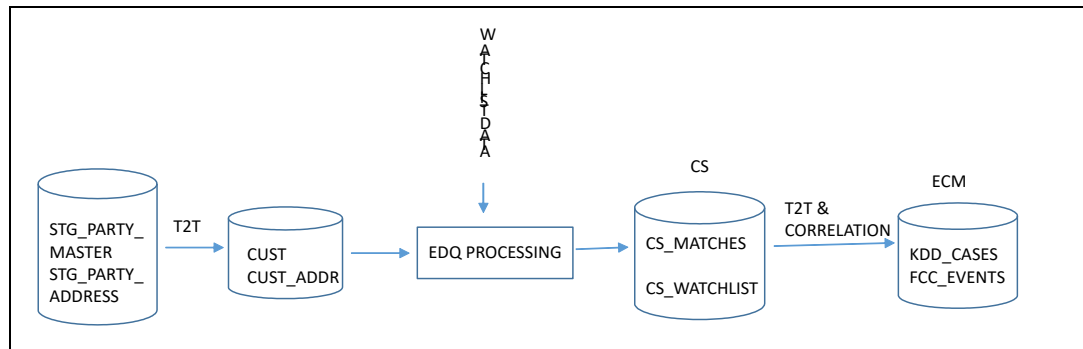

The steps are explained below:

1. Data is moved from the `stg_party_master`, `stg_party_address`, `stg_casa`, `stg_loan_contracts`, `stg_party_account_role_map`, `stg_party_role_map`, `stg_td_contracts`, `stg_trading_account`, and `stg_party_other_names` tables to the `cust` table, `cust_addr` table, `acct` table, `cust_name` and other associated customer tables using T2T.
2. The watch list data is downloaded from the watch list management project in EDQ. This watch list data is matched with the data in the `cust` and `cust_addr` tables in the Customer Screening project.
3. The matches are then loaded into the `cs_matches` table and the corresponding watch list data is loaded into the `cs_watchlist` table.
4. Data from the `cs_matches_hist` table is generated as alerts in the `cs_alerts` and `cs_alerts_matches` tables.

### NOTE

The `cs_matches_hist` table contains all matches. Each time screening is run, the `cs_matches` table is compared to the `cs_matches_hist` table and any new or changed matches are added to the `cs_matches_hist` table and used to create new alerts. Every time you run the customer screening project, data is truncated in the `cs_matches` table.

5. Data is correlated and loaded into the `kdd_cases` and `fcc_events` tables in ECM.



## 2 General Configurations

The sections in this chapter describe the following general configuration areas for Oracle Financial Services Customer Screening:

- [Configuring Watch List Management, Customer Screening, External Entity Screening and Real-Time Screening](#)
- [Configurations for Delta Updates](#)
- [Filtering Watch List Data](#)
- [Configuring Enterprise Case Management \(ECM\)](#)
- [Scheduling the Customer Screening Run Job](#)
- [Risk Scoring](#)
- [Configurations for GDPR](#)

### 2.1 Configuring Watch List Management, Customer Screening, External Entity Screening and Real-Time Screening

The Watch List Management, Customer Screening, External Entity, and Real-time screening properties can be configured using Run Profiles. Run Profiles are optional templates that specify a number of override configuration settings for externalized options when a Job is run. They offer a convenient way of saving and reusing a number of configuration overrides, rather than specifying each override as a separate argument.

Run Profiles are used when running jobs using the `runopsjob` command from the Batch Scheduler. For further information about Run Profiles and using the Command Line Interface, see the [OEDQ online help](#).

Oracle Financial Services Customer Screening distribution contains the following Run Profiles:

- `watchlist-management.properties`
- `customer-screening.properties`
- `external-entity.properties`
- `customer screening- real time.properties`

The `watchlist-management.properties` Run Profile controls:

- which watch lists are downloaded, and the configuration of the download process;
- whether filtering is applied to the watch lists; and
- whether Data Quality Analysis is applied to the watch lists.

The `customer-screening.properties`, `external-entity.properties` and `customer screening- real time` Run Profiles control:

- Real-Time or Batch Screening set up;
- Screening reference ID prefixes and suffixes;
- Watch list routing; and
- configuration of match rules.

**NOTE**

The properties controlling match rules are not included in the `customer-screening.properties`, `external-entity.properties`, and `customer screening- real time.properties` Run Profiles by default. See [Configuring Match Rules](#) for further information.

### 2.1.1 Preparing Watch List Data

Oracle Financial Services Customer Screening is pre-configured to handle reference data from the following sources:

- HM Treasury
- OFAC
- EU consolidated list
- UN consolidated list
- World-Check
- Dow Jones Watchlist
- Dow Jones Anti-Corruption List
- Accuity

Additionally, you can optionally supply reference data from your own private watch list using the Private List Interface (PLI).

Values in the `watchlist-management.properties` Run Profile control which lists are used and how they are downloaded, staged, and filtered (or not).

**NOTE**

1. Watch lists can be downloaded automatically (by setting the appropriate values in the Run Profile) or manually (by navigating to the list provider's web site, downloading the list and saving it to the matching sub-folder in the Landing Area).
2. The staging value must be set to Y the first time a watch list is downloaded. Thereafter, leave it set to Y to refresh the staged data every time a download is performed, or N to preserve the pre-existing staged data.
3. All downloaded watch lists must be set to **filtered** or **unfiltered**.
4. The Accuity, Dow Jones, Dow Jones Anti-Corruption and World-Check lists are all provided as paid services. To use one of these watch lists it is necessary to apply to the individual list providers for an account. Please refer to the relevant provider websites for further information.
5. The option to download private watch lists is not supplied, as it is assumed that this data will be available in house.

For specific configuration information on each of these watch lists, [see Watch List Information](#).

## 2.1.1.1 Example - Preparing the Accuity list

This example describes how to edit the `watchlist-management.properties` Run Profile to allow the download and configuration of the Accuity list. The steps in the example can be applied, with little modification, to other data lists.

### 2.1.1.1.1 Download and Staging

To automatically download the Accuity list, set the following values to Y:

```
phase.ACY\ -\ Download.enabled
phase.ACY\ -\ Stage\ reference\ lists.enabled
```

#### NOTE

To manually download the Accuity list, leave these values set to **N**. Navigate to the URL provided in the Accuity Reference Data section, download the list and save it to the `config/landingarea/Accuity` subfolder.

### 2.1.1.1.2 Filtering

To prepare the Accuity list with filtering, set the following value to Y:

```
phase.ACY\ -\ Prepare\ without\ filtering.enabled
```

To prepare the Accuity list without filtering, set the following values to Y:

```
phase.ACY\ -\ Prepare\ with\ filtering\ (Part\ 1).enabled
phase.ACY\ -\ Prepare\ with\ filtering\ (Part\ 2).enabled
```

For details of how to configure watchlist filtering, See [Filtering Watch List Data](#).

### 2.1.1.1.3 Data Quality Analysis

To enable Data Quality analysis for the Accuity list, set the following values to Y:

```
phase.DQ\ -\ Stage\ ACY\ reference\ lists.enabled
phase.DQ\ -\ ACY\ reference\ data\ quality\ analysis.enabled
stageddata.DQ\ ACY\ -\ Invalid\ Standard\ Country\ in\ Accuity\
Nationality\ to\ Standard\ Country.visible
stageddata.DQ\ ACY\ -\ Missing\ Source\ in\ Accuity\ Source\ Risk\
Scores\ Reference\ Data.visible
stageddata.DQ\ ACY\ -\ Obsolete\ Source\ in\ Accuity\ Source\ Risk\
Scores\ Reference\ Data.visible
```

### 2.1.1.1.4 Enable phases for download and staging

To enable automated download of the Accuity list, the OEDQ server must be connected to the internet.

Enter the username and password combination for the Accuity login in the values ending:

```
ftp://username:password@ftp.financialgo.net/PIDGWL.ZIP
```

If the OEDQ server is connected to the internet via a proxy, set the following properties:

- `proxy_host`

- proxy\_port
- proxy\_username
- proxy\_password

## 2.1.2 Private Watch List Set Up

Oracle financial services Customer Screening is pre-configured to work with a number of commercially-available and government-provided watch lists. However, you can also screen against your own private watch lists. On installation, screening is configured to run against a sample private watch list with minimal additional configuration, allowing the installation to be validated quickly. The sample private watch list is provided in two files - `privateindividuals.csv` and `privateentities.csv` - in the `config/landingarea/Private` folder.

### NOTE

Your OEDQ instance's config folder might not be named *config*. The choice of the config folder's name is made when OEDQ is installed - in some cases a name is automatically allocated. OEDQ release 11g and later has both a *base* and a *local* config folder. The base config folder is often called *oedqhome*, and the local config folder is often called *oedqlocalhome*. In some cases, dots or underscores may be inserted into these names (For example, `oedq_local_home`). Whenever you see a file path in this document that begins with `config`, this always refers to your OEDQ instance's local config folder.

The first step in screening against your own private watch list is to replace the data in the supplied files with your own data. To do this:

1. Transform your private watch list data into the format specified by the Private List Interface (see the Data Interfaces Guide for further information).
2. Replace the data in the `privateindividuals.csv` and `privateentities.csv` files with your transformed private watch list data.

### NOTE

1. The files must be saved in UTF-8 format.
2. To screen against multiple private watch lists, consolidate them into the two files: `privateindividuals.csv` and `privateentities.csv`. These two files can also be used to hold data from external watch lists that Oracle Financial Services Customer Screening is not pre-configured to work with.

The second and final step is to enable the staging and preparation of the private watch list in the `watchlist-management.properties` Run Profile. To stage your private watch list set the following value to Y:

```
phase.PRIV\ -\ Stage\ reference\ lists.enabled
```

Once you have done this, set the following value to **Y** to prepare the private watch list without filtering:

```
phase.PRIV\ -\ Prepare\ without\ filtering.enabled
```

You can also set both of the following values to **Y** to prepare the private watch list with filtering:

```
phase.PRIV\ -\ Prepare\ with\ filtering\ (Part\ 1).enabled
```

```
phase.PRIV\ -\ Prepare\ with\ filtering\ (Part\ 2).enabled
```

### 2.1.3 Showing Watch List Staged Data/Snapshots in the Server Console UI

Certain types of staged data and snapshots are hidden in the Server Console UI by default. These are:

- Watch list snapshots
- Intermediate filtered watch list staged data
- Centralized Reference Data staged data/snapshots

To display this data, set the corresponding visibility property value(s) in the relevant Run Profile(s) to **Y**.

For example, to make all Accuity watch list snapshots generated during Watchlist Management visible, set the following properties in the `watchlist-management.properties` Run Profile:

```
stageddata.ACY\ Sources.visible = Y
```

```
stageddata.ACY_All.visible = Y
```

```
stageddata.ACY_Sources.visible = Y
```

### 2.1.4 Configuring Match Rules

Match rules - and also match clusters - can be configured and controlled by adding a property to the `customer-screening.properties` and `external-entity.properties` Run Profiles.

For example, to disable the **Exact name only** rule for Batch and Real-Time Sanctions screening, add the following property to the Run Profile:

```
phase.*.process.*.[I0100]\ Exact\ name\ only.san_rule_enabled = false
```

The **\*** character denotes a wildcard, and therefore specifies that the above rule applies to all phases and all processes. If disabling the rule for Batch screening only, the property would read:

```
phase.Batch\ screening.process.*.[I0100]\ Exact\ name\ only.san_rule_enabled = false
```

#### NOTE

Capitalization must be respected and characters must be escaped as required.

For further details on tuning Match rules, please refer to the [Oracle Financial Services Customer Screening Matching Guide](#).

## 2.1.5 Real-Time and Batch Screening Set Up

By default, Real-Time and Batch screening is enabled for SAN, PEP and EDD records.

This is controlled by the Real-Time and Batch screening properties in the `customer-screening.properties` and `external-entity.properties` Run Profiles. Using these properties, it is possible to enable or disable Real-Time or Batch screening for all records or by record type.

For example, to only run Real-Time screening for PEP and EDD individual and entity records, change the value of the following properties as indicated:

```
phase.Start\ Batch\ Screening.enabled = N
phase.Real-time\ Screening.process.Individual\ Real-time\
Screening.san_enabled = N
phase.Real-time\ Screening.process.Entity\ Real-time\
Screening.san_enabled = N
```

**NOTE** Ensure all other Real-Time screening properties are set to Y.

## 2.1.6 Outputting Relationships Data to Files

Screening identifies possible relationships, or possible matches, between individuals and entities in your customer data and the external entities on watch lists. These relationships form the basis of the events and cases that you can review in Enterprise Case Management. When you run screening in batch, as well as outputting these relationships to the Customer Screening data layer, you can also output them to `.csv` files. This can be useful if, for example, you want to use Oracle Financial Services Customer Screening to identify the relationships, but you want to review them using another system.

To enable the output of relationships data to files, set the following values to Y in the Batch Screening Setup section of the `customer-screening.properties` and `external-entity.properties` Run Profiles:

```
phase.*.process.*.output_relationships
phase.Export\ Batch\ Relationships.enabled
```

When you run screening with these run profile parameters enabled, two files are created:

- `relns-ent-batch.csv` (which holds relationship data for entities).
- `relns-ind-batch.csv` (which holds relationship data for individuals).

The two files are placed in the `config/landingarea/sentryrelns` folder.

## 2.2 Configurations for Delta Updates

Oracle recommends that you always run the full watchlist. This is the best way to ensure the latest data is used.

**NOTE** Customer Screening always uses the full watchlist. There is no need to perform delta screening due to the clustering strategy which is implemented in our screening processes.

Although using the full watchlist is recommended, some customers may need to download and process watchlist delta files, either due to the time when the files are made available or time taken to download the files.

Customers who need to download and process the watchlist delta files must first do so and then combine them with previous full watchlists before screening the files through the database.

**NOTE** The full list data is available in the `FSI_WATCHLIST_INDIVIDUAL` and `FSI_WATCHLIST_ENTITIES` tables, and the delta updates are available in the `FSI_WATCHLIST_DELTA_INDIVIDUAL` and `FSI_WATCHLIST_DELTA_ENTITIES` table.

Before you run the delta watchlist files, ensure that you run the full watchlist files. You can run the full watchlist files if, for example, delta downloads have failed for multiple days or the filter criteria are changed. You can also run the full watchlist once every week to ensure that the complete data has been processed.

## 2.2.1 General Configurations

The following configurations must be done for both the full watchlist and delta updates:

1. Set `phase.Initialise\ staged\ data.enabled` to **N** to disable the .jmp file updates.
2. Set `phase.Initialise\ staged\ data\ DB.enabled` to **Y** to initialize the database.
3. Set `phase.Initilize\ Prepared\ List\ Data.enabled` to **N** to disable the .jmp file updates.
4. Set `phase.Initilize\ Prepared\ List\ Data\ DB.enabled` to **Y** to prepare the database.
5. To enable the following phase to prepare DJW without filtering, set the value for `phase.DJW\ -\ Prepare\ without\ filtering\ DB.enabled` to **Y**.
6. To enable the following phases to prepare DJW with filtering enabled, set `phase.DJW\ -\ Prepare\ with\ filtering\ DB.enabled` to **Y**.

## 2.2.2 Running the Full Watchlist

To run the full watchlist updates:

1. Navigate to `EDQ_Run_Profile_FOLDER`.
2. Edit the `watchlist management.properties` file as mentioned below:
  - Set `phase.DJW\ -\ Download.enabled` to **Y**.
  - Set `phase.DJW\ -\ Download\ Delta.enabled` to **N**.

- Set phase.DJW\ -\ Stage\ reference\ lists.enabled to **Y**.
  - Set phase.\*.export.\*.ind\_table\_name to FSI\_WATCHLIST\_INDIVIDUAL.
  - Set phase.\*.export.\*.entities\_table\_name to FSI\_WATCHLIST\_ENTITIES.
  - Set phase.Dow\_Jones\_Import1\_Full\_DB.enabled to **Y**.
  - Set phase.Dow\_Jones\_Import2\_Full\_DB.enabled to **Y**.
  - Set phase.Dow\_Jones\_Import3\_Full\_DB.enabled to **Y**.
3. To enable the watchlist external task, set phase.WatchListLoadPreparedData.enabled to **Y**.
  4. To enable the external task and execute the transaction full list:
    - Set phase.WatchListLoadData.enabled to **Y**.
    - Set phase.SanctionedListRefLoadData.enabled to **N**.
    - Set phase.WatchListLoadDeltaData.enabled to **Y**.

### 2.2.3 Running the Delta Updates

To run the delta updates:

1. Navigate to EDQ\_Run\_Profile\_FOLDER.
2. Edit the watchlist management.properties file as mentioned below:
  - phase.DJW\ -\ Download.enabled = N
  - phase.DJW\ -\ Download\ Delta.enabled = Y
  - phase.DJW\ -\ Stage\ reference\ lists.enabled = Y
  - Run  
phase.\*.export.\*.ind\_table\_name=FSI\_WATCHLIST\_DELTA\_INDIVIDUAL and  
phase.\*.export.\*.entities\_table\_name=FSI\_WATCHLIST\_DELTA\_ENTITIES.
3. To merge the delta updates to the full list:
  - Set phase.Delta\ Merge.enabled to **Y**.
  - Set phase.Linked\ Profiles.enabled to **Y**.

### 2.2.4 Additional Configurations

If required, you can also do the following:

- To run DQ for DJW, set the following values to Y to download the delta updates:
  - phase.DQ\ -\ Stage\ DJW\ reference\ lists.enabled = Y
  - phase.DQ\ -\ DJW\ reference\ data\ quality\ analysis.enabled = Y
  - stageddata.DQ\ DJW\ -\ Invalid\ Standard\ Country\ in\ DJ\ Country\ to\ Standard\ Country.visible = Y



- 
- stageddata.DQ\ DJW\ -\ Missing\ Category\ in\ DJW\ SI\ Category.visible = Y
  - stageddata.DQ\ DJW\ -\ Missing\ Category\ in\ DJW\ SI\ Category\ Description.visible = Y
  - stageddata.DQ\ DJW\ -\ Missing\ DJW\ Country\ in\ DJ\ Country\ to\ Standard\ Country.visible = Y
  - stageddata.DQ\ DJW\ -\ Missing\ Name\ in\ DJW\ List\ Provider\ Reference\ Data.visible = Y
  - stageddata.DQ\ DJW\ -\ Missing\ Occupation\ Name\ in\ DJW\ Occupation\ Category.visible = Y
  - stageddata.DQ\ DJW\ -\ Obsolete\ Category\ in\ DJW\ SI\ Category.visible = Y
  - stageddata.DQ\ DJW\ -\ Obsolete\ Category\ in\ DJW\ SI\ Category\ Description.visible = Y
  - stageddata.DQ\ DJW\ -\ Obsolete\ DJW\ Country\ in\ DJW\ Country\ to\ Standard\ Country.visible = Y
  - stageddata.DQ\ DJW\ -\ Obsolete\ Name\ in\ DJW\ List\ Provider\ Reference\ Data.visible = Y
  - stageddata.DQ\ DJW\ -\ Obsolete\ Occupation\ Name\ in\ DJW\ Occupation\ Category.visible = Y
- To switch from the Windows batch file to the Linux shell script:
    - **comment out** phase.DJW\ -\ Download.externaltasks.Download\ Dow\ Jones\ Watchlist.command = download-djw.bat.
    - **uncomment** phase.DJW\ -\ Download.externaltasks.Download\ Dow\ Jones\ Watchlist.command = download-djw.sh.

## 2.3 Filtering Watch List Data

### 2.3.1 Enabling Watch List Filtering

Watch list data is filtered either during List Management, Screening, or both.

To enable filtering for a specific watch list, set the Prepare Filtering phase(s) in the appropriate Run Profile to **Y**, and the Prepare Without Filtering phase(s) to **N**.

### 2.3.2 Configuring Watch List Filtering

Watchlist filtering is controlled by configuring reference data in the Watchlist projects.

**NOTE**

1. The reference data sets in Watchlist Management and Watchlist Screening projects are identical. This is to support installations requiring filtering at different stages. For example, a company may wish to perform initial filtering as watch list data is prepared, and then run several screening projects on specific parts of that data (by country, origin, etc.).
2. Once data is filtered out, it is not possible to filter it back in. E.g. if all entities are filtered out in Watchlist Management, even if the Watchlist Screening project is configured to include entities, they will not show up in results data.

The top level of filtering is controlled by editing the Filter - Settings reference data:

The screenshot shows a window titled "Reference Data Editor - Filter - Settings" with a table of 20 records. The table has columns for List Key, List Sub Key, List/sub-lis..., Individuals..., Entities (Pr..., Vessels (P..., All origins ..., All origin r..., All origin s..., and All name ty... All values in the table are 'Y'.

List Key	List Sub Key	List/sub-lis...	Individuals...	Entities (Pr...	Vessels (P...	All origins ...	All origin r...	All origin s...	All name ty...
ACY	ACY-SAN	Y	Y	Y	Y	Y	Y	Y	Y
ACY	ACY-PEP	Y	Y	Y	Y	Y	Y	Y	Y
ACY	ACY-EDD	Y	Y	Y	Y	Y	Y	Y	Y
HMT	HMT-CONS	Y	Y	Y	Y	Y	Y	Y	Y
HMT	HMT-IB	Y	Y	Y	Y	Y	Y	Y	Y
EU	EU	Y	Y	Y	Y	Y	Y	Y	Y
DJW	DJW-SAN	Y	Y	Y	Y	Y	Y	Y	Y
DJW	DJW-PEP	Y	Y	Y	Y	Y	Y	Y	Y
DJW	DJW-EDD	Y	Y	Y	Y	Y	Y	Y	Y
OFAC	OFAC-SDN	Y	Y	Y	Y	Y	Y	Y	Y
OFAC	OFAC-NS-PLC	Y	Y	Y	Y	Y	Y	Y	Y
UN	UN-ALQ	Y	Y	Y	Y	Y	Y	Y	Y
UN	UN-TAL	Y	Y	Y	Y	Y	Y	Y	Y
WC	WC-SAN	Y	Y	Y	Y	Y	Y	Y	Y
WC	WC-PEP	Y	Y	Y	Y	Y	Y	Y	Y
WC	WC-EDD	Y	Y	Y	Y	Y	Y	Y	Y
PRIV		Y	Y	Y	Y	Y	Y	Y	Y
DJAC	DJAC-SAN	Y	Y	Y	Y	Y	Y	Y	Y
DJAC	DJAC-PEP	Y	Y	Y	Y	Y	Y	Y	Y
DJAC	DJAC-EDD	Y	Y	Y	Y	Y	Y	Y	Y

All the reference data filters are set to Y by default, except Linked Profiles which is set to N. Unless these settings are changed, no actual filtering is performed on watch list data.

In the Filter - Settings reference data, a value of Y indicates that all records should be included - in other words, no filter should be applied.

Broadly speaking, watch list filtering falls into four categories:

1. By list and list sub key.
2. By list record origin characteristics.
3. By list profile record characteristics.
4. By linked profiles.

### 2.3.3 Primary and Secondary Filtering, and Linked Records

The usage of Primary filters, Secondary filters, and Linked Profiles are mentioned below:

1. Primary filtering - These filters are used to return all profiles that match the criteria specified.
2. Linked Profiles - If this value is set to Y, then all profiles linked to those captured by Primary filters are also captured; an example of use is a filter configured to capture all Sanctions and their related PEPs.
3. Secondary filtering - These filters are applied to further filter any linked profiles that are returned.

**NOTE**

Only the World-Check and DJW watch lists can provide Linked Profiles.

### 2.3.4 Setting Multiple Values for Primary and Secondary Filters

The following filter options require further configuration in additional reference data:

1. Origins
2. Origin Regions
3. Origin Statuses
4. Primary and Secondary Name Qualities
5. Primary and Secondary Name Types
6. Primary and Secondary PEP Classifications

To filter using one or more of these options, set the relevant value in the Filter - Settings reference data to N, and then make further changes to the corresponding reference data.

The effect of setting a value in the Filter - Settings reference data to N is that only records that match values set in the corresponding reference data will be included. For example, if you set the value of All name qualities (Primary)? to N in Filter - Settings, then, in the Filter - Primary Name Qualities reference data you could determine which name qualities should be included for each watch list. For instance, if you include a row for High quality names in the EU watch list, but you do not include rows for medium and low quality names for this watch list, then only records with high quality names will be included for this watch list.

Some of these reference data sets will be prepopulated with rows, to be edited or removed as required. These rows contain data (generally, but not always) supplied by each watch list provider, and are all contained within the Watchlist Management project.

For example, to view all possible keywords for World-Check data, open the WC Keyword reference data in the Watchlist Management project. See the following example for further details.

## 2.3.4.1 Example - Filtering World Check Data

This example describes configuring filtering on the World-Check Sanctions list in the Watchlist Management project, and setting further filters in the Watchlist Screening project. Specifically,

1. Enabling filtering in the Run Profiles;
2. Configuring the Primary filters in the Watchlist Management project to return only active records for sanctioned individuals (not entities) originating from the EU list;
3. Enabling the filtering of Linked Profiles in the Watchlist Management project; and
4. Configuring the Secondary filters in the Watchlist Screening project to further filter out all Linked Profiles of deceased individuals.

### 2.3.4.1.1 Setting filtering options in the Run Profiles

In the `watchlist-management.properties` Run Profile, set the World-Check filtering phases as follows:

1. `phase.WC\ -\ Prepare\ without\ filtering.enabled = N`
2. `phase.WC\ -\ Prepare\ with\ filtering\ (Part\ 1).enabled = Y`
3. `phase.WC\ -\ Prepare\ with\ filtering\ (Part\ 2).enabled = Y`

In the `customer-screening.properties` Run Profile, set the World-Check filtering phases as follows:

4. `phase.WC\ -\ Load\ without\ filtering.enabled = N`
5. `phase.WC\ -\ Load\ with\ filtering\ (Part\ 1).enabled = Y`
6. `phase.WC\ -\ Load\ with\ filtering\ (Part\ 2).enabled = Y`

### 2.3.4.1.2 Setting Primary Filters and Linked Profiles in the Watchlist Management project

Follow these steps to set primary filters and linked profiles in the project:

1. In Director, open the Watchlist Management project and expand the Reference Data node.
2. Locate the Filter - Settings reference data, and double-click to open it.
3. Ensure the `List/sub-list (Primary?)` value in the `WC-SAN` row is set to **Y**.
4. Set the `Entities (Primary)?` value in the `WC-SAN` row to **N**.
5. Set the `Inactive (Primary)?` value in the `WC-SAN` row to **N**.
6. Set the `All Origins (Primary)?` value in the `WC-SAN` row to **N**.
7. Ensure all other values in the `WC-SAN` row are set to **Y**.
8. Click **OK** to close the reference data and save changes.
9. Locate the Filter - Origins reference data and double-click to open it.
10. Add a new row with the following values:
  - a. List Key - WC
  - b. List Sub Key - WC-SAN
  - c. Origin - EU

11. Change the `Linked Profiles?` value in the `WC-SAN` row to **Y**.
12. Click **OK** to close the Filter Settings reference data and save changes.

#### 2.3.4.1.3 Setting Secondary Filters in the Watchlist Screening project

Follow these steps to set primary filters and linked profiles in the project:

1. Open the Watchlist Screening project, and expand the reference data link.
2. Locate the Filter - Settings reference data file, and double-click to open it.
3. Set the `Deceased (Secondary)?` value in the `WC-SAN` row to **N**.
4. Click **OK** to close the reference data and save changes.

### 2.3.5 Screening All Data Using Sanctions Rules

By default, watch list records are routed to the different screening processes depending on their record type (that is, SAN, PEP or EDD). This allows different rules, and hence different levels of rigor, to be applied to the list data according to risk appetite.

However, if you want to use the same screening logic for all list records, and do not want the overhead of maintaining separate rulesets, the system can be configured to reroute all list records to the SAN screening processes. To do this, set the `phase.*.process.*.Screen\ all\ as\ SAN?` value in the `customer-screening.properties` Run Profile to **Y**.

## 2.4 Configuring Enterprise Case Management (ECM)

Oracle Financial Services Customer Screening uses the Enterprise Case Management application to investigate and manage cases and events generated by the matching processes.

The following sections describe the default case types and workflows provided with Oracle Financial Services Enterprise Case Management, but all of these can be edited to suit your requirements. For full instructions on editing workflows and case sources, please refer to the [Oracle Financial Services Enterprise Case Management Admin Guide](#).

### 2.4.1 Case Class in ECM

For Oracle Financial Services Customer Screening Application, the following case classes have been added in the Oracle Financial Services Enterprise Case Management Application:

- CS
- CS\_EE
- CS\_RT

To add further new case classes, follow the steps in Adding Case Class in the [Oracle Financial Services Enterprise Case Management Admin Guide](#).

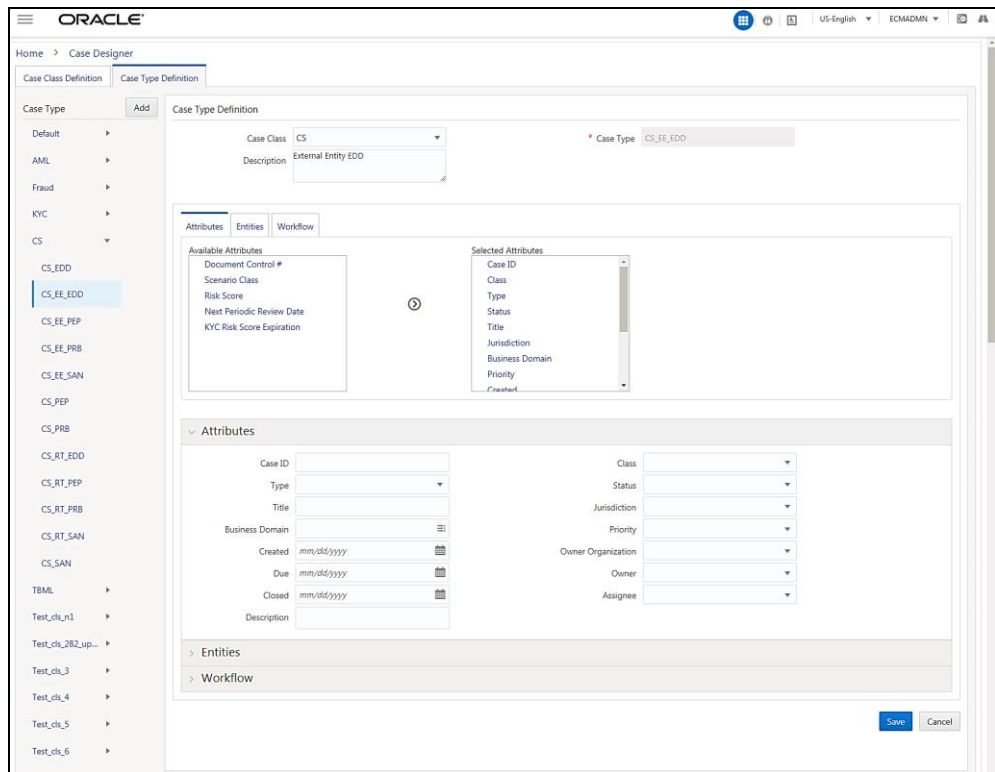

## 2.4.2 Case Types under Case Class

The following case types are created for the CS case class:

- **CS\_EDD** : Enhanced Due Diligence (EDD)
- **CS\_EE\_EDD**: Enhanced Due Diligence (EDD) for External Entity screening
- **CS\_EE\_PEP**: Politically Exposed Person (PEP) for External Entity screening
- **CS\_EE\_PRB**: Prohibition (PRB) for External Entity screening
- **CS\_EE\_SAN**: Sanctions (SAN) for External Entity screening
- **CS\_PEP**: Politically Exposed Person (PEP)
- **CS\_PRB**: Prohibition (PRB)
- **CS\_RT\_EDD**: Enhanced Due Diligence (EDD) for Real Time screening
- **CS\_RT\_PEP**: Politically Exposed Person (PEP) for Real Time screening
- **CS\_RT\_PRB**: Prohibition (PRB) for Real Time screening
- **CS\_RT\_SAN**: Sanctions (SAN) for Real Time screening
- **CS\_SAN**: Sanctions (SAN)

For each Case Type, default Entities (Tabs) have been mapped. If additional Entities (Tabs) are required, follow the steps in Adding Optional Entities to the Case Type in [Oracle Financial Services Enterprise Case Management Admin Guide](#).

## 2.4.3 Creating Workflows for Case Types

For each of the aforementioned Case Types, a workflow is also mapped. To create a workflow, see the section *Creating a Business Process* in [OFSAAI User Guide](#).

Two workflows are provided by default, one for Sanctions Cases and the other which is used for Politically Exposed Persons (PEP), Enhanced Due Diligence (EDD) and Country Prohibition (PRB) cases. For more information, see [Workflow Diagrams](#).

## 2.4.4 Searching Customer Screening related Cases in Oracle Financial Services ECM

Once the Oracle Financial Services Customer Screening batch is run, events are correlated into cases based on watch list record type, so there may be up to four open cases for a customer, one for Sanctions, one for Country Prohibitions, one for Politically Exposed Persons, and one for Enhanced Due diligence events. Correlation rules may be changed if required. The Related Cases Tab will have links to other cases for the given customer.

There are certain ready-to-use Customer Screening case type search criteria. They can be viewed in the Search Cases tab in ECM. To view these fields, click More Search Criteria and select a CS type in the Type field. A new search section called Optional Case Attributes is displayed with the search criteria. For more information on the search fields, see the section Searching Cases in [Oracle Financial Services Enterprise Case Management User Guide](#).

## 2.4.5 Taking Action on Customer Screening related Cases in Oracle Financial Services ECM

The Workflow Actions for Customer Screening Cases depend on the Case Type, User and Status. To take action on a case, follow the steps in Using Take Action Window in [Oracle Financial Services Enterprise Case Management User Guide](#).

The following figure shows a sample of an EDD Workflow which has a *Pending Review* status and logged-in user as *Supervisor*.

The screenshot shows a 'Take Action' dialog box with the following sections and options:

- Selected Cases:** CA100
- Due Date:**
  - Clear Due Date
  - Set Due Date
- Email:**
  - Send Email
  - Send RFI
- Resolution:**
  - Close without SAR
  - Close and Generate SAR
- Assign:**
  - Auto Assignment
  - Set Case Owner
  - Set Case Assignee
- Evidence:**
  - Add Comment
  - Attach Document

Buttons: Save, Cancel

**NOTE**

1. When a decision is taken at the event level, it is possible to configure whether the comments can be made mandatory or optional.
2. To make comments mandatory, set the values of the REQ\_CMMNT\_FL column in the KDD\_ACTION table to Y. In this case, the decision cannot be saved until you provide a comment.
3. To make comments optional, set the values of the REQ\_CMMNT\_FL column in the KDD\_ACTION table to N. In this case, the decision can be saved even if you do not provide a comment.

## 2.4.6 Match Persistence and Flag Keys

Customer Screening screens all customer records against all required watchlist records on a daily basis. This allows new events to be created due to changes in either the customer or the watchlist data. Where there is no change to the customer or the watchlist record and the match is identical to a previously generated relationship no new event is created.

Many attributes can change on a customer or watchlist record but not all should trigger a new event to be reviewed. A flag key is a set of fields in the data which are considered significant when evaluating a match to present a new event to Case Management.

**NOTE**

If a new alias name of a list record is added that matches the customer record this will be presented as a new event.

An example of a potential flag key field is date of birth; some potential matches may be eliminated on the grounds that the date of birth is too different between the customer and watch list records. Therefore, if the date of birth information on either list changes, it is likely that any potential matches which depend on it should be re-reviewed. An example of a field which should not be included in the flag key is account balance. This contains a value which is likely to change rapidly but which does not have any impact on the match decisions.

Flag keys are set in individual match processes and then a hash value is generated which is used for comparison.

**NOTE**

The order of fields in the flag key is important; changing the order will treat the relationship as a new match.

## 2.5 Scheduling the Customer Screening Run Job

To execute a Customer Screening Run job, follow these steps:

1. Navigate to FCI\_DB\_HOME/bin.



2. Execute `EDQInsert.sh` by passing `infodom`. This step is used to register the EDQ server details. Enter the EDQ server IP, JMX port number, user name and password details.

**NOTE** The JMX port number must be 8090.

For example, `./EDQInsert.sh INFODOM NAME`. Replace the `INFODOM NAME` placeholder with your domain name.

```
/scratch/ofsaadb/ES807AX/ES807AX/ficdb/bin>./EDQInsert.sh ES807AXINFO
Started finding Jars
Ended finding Jars
Classpath Created
Calling EDQ Main Method
Inside EDQ insert method
Enter EDQ Server IP:
10.184.152.8
Enter EDQ Server Director Port:
8090
Enter EDQ Server User Name:
weblogic
Enter EDQ Password:
Encrypting password
Enter ECM URL:
https://whf00avg.in.oracle.com:4752/ES807AX
Is Enterprise Case Management Application in the same installation? (Y/N)
N
Enter ECM User Name:
CSConnect
Enter ECM Password:
Encrypting password
```

You must create a new ECM user which has no case privileges, for example, `CSConnect`.

3. For a pack on pack installation with Enterprise Case Management (ECM), you must run the `./EDQInsert.sh` script again. An entry is then made in the `ATOMIC` schema in the `cs_appln_params` table.

```
/scratch/ofsaadb>./EDQInsert.sh ECMSAN80700INFO
Started finding Jars
Ended finding Jars
Classpath Created
Calling EDQ Main Method
Inside EDQ insert method
Enter EDQ Server IP:
10.184.152.8
Enter EDQ Server Director Port:
8090
Enter EDQ Server User Name:
weblogic
Enter EDQ Password:
Encrypting password
Enter ECM URL:
https://whf00ane:5632/E80700S
Is Enterprise Case Management Application in the same installation? (Y/N)
Y
Encrypting password
configurationPath:::/scratch/ofsaadb/E80700S/E80700S
FIC_HOME:/scratch/ofsaadb/E80700S/E80700S/
```

4. Copy the EDQ run profile to `FIC_DB_HOME/conf` folder. Name should be exactly same as `customer-screening.properties`.
5. Load the stage table data for customer related tables. It is mandatory for Customer and Customer Address.
6. Run the `Truncate_Tables` job in the Rule Run Framework screen.

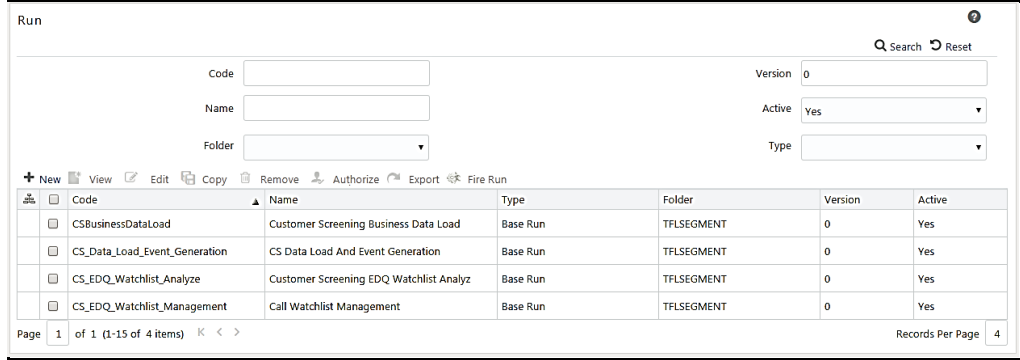

7. Fire the `CS_Data_Load_Event_Generation` run.

The batches must be run in the following order:

Sequence	Batch Name	Description
#1	CS_EDQ_Watchlist_Management	This is used to restart the batch and real-time screening web services. This job must be run daily.
#2	CS_EDQ_Watchlist_Analyze	This needs to be executed only if we need to chk the Data Quality of the Download Watchlist.
#3	CSBusinessDataLoad	This is used to run the data load from staging. This job needs to be run only if it has not been run as a result of the other scheduled processes.
#4	CS_Data_Load_Event_Generation	This is used to run parallel batches for each jurisdiction.

**NOTE**

1. The `CSBusinessDataLoad` job is used to run the data load from staging. This job needs to be run only if it has not been run as a result of the other scheduled processes.
2. The `CS_EDQ_Watchlist_Analyze` job is used to Analyze the processes in EDQ. This job needs to be run as and when required.
3. The `CS_EDQ_Watchlist_Management` is used to restart the batch and real-time screening web services. This job must be run daily.

---

## 2.5.1 Loading Data into the CUST tables

Once the job is run, data is truncated and loaded back into the CUST tables. To prevent this, follow these steps:

1. Login as CSADMN.
2. Click **Common Tasks >> Rule Run Framework >> Run**. The Run page appears.
3. Click **Run** in the RHS menu.
4. Select the checkbox for `CS_Data_Load_Event_Generation`.
5. Click **Edit**.
6. In the Selector menu, click **Job**. The Job window appears.
7. Select the checkbox for `Truncate_Tables`.
8. Click . The Parameters window appears.
9. Change the parameter value to **N**.
10. Click **OK** to close the Parameters window.
11. Click **OK** to close the Job window.
12. Click **Next**.
13. Click **Save**.

## 2.5.2 Creating and Running Parallel Batches

Parallel batches can be run in CS if you want to run batches which have different jurisdictions at the same time. To run parallel batches, you can run the `CS_Data_Load_Event_Generation` job for each jurisdiction.

To create parallel batches, do the following:

### 2.5.2.1 Create a process

To create a process, do the following:

1. Log on to the Customer Screening application.
2. Click **Common Tasks >> Rule Run Framework >> Run**. The Run page appears.
3. Make an entry in the `cs_processing_group` table. For ex, `GROUP_US`.
4. Search for Start in the Code field.
5. Select `CS_End_To_End_Start_Batch`.
6. Click **Copy**. The Run page appears in Copy Mode.
7. In the Folder field, click the folder icon.
8. Click `TFLSEGMENT`.
9. In the Name field, change the job name to include the Jurisdiction Code. For example, `CS_Data_Load_Event_Generation_US`.
10. Select `F_CS_BATCH_RUN`.
11. Select Component.

12. In the Parameter field, change the parameter ORACLECS to the entry made in the `cs_processing_group` table, for example, `GROUP_US`, and the parameter CS to the Jurisdiction Code, for example, `US`.
13. Click **OK**.
14. Click **OK**.
15. Click **Save**.
16. Search for End in the Code field.
17. Select `CS_End_To_End_End_Batch`.
18. Click **Copy**. The Run page appears in Copy Mode.
19. In the Folder field, click the folder icon.
20. Click `TFLSEGMENT`.
21. In the Name field, change the job name to include the Jurisdiction Code. For example, `CS_Data_Load_Event_Generation_US`.
22. Select `F_CS_BATCH_RUN`.
23. Select Component.
24. In the Parameter field, change the parameter ORACLECS to the entry made in the `cs_processing_group` table, for example, `GROUP_US`, and the parameter CS to the Jurisdiction Code, for example, `US`.
25. Click **OK**.
26. Click **OK**.
27. Click **Save**.

A confirmation message appears. The new parameter is now displayed in the Run page.

**NOTE**

In the example above, the new processing batch name has been changed from CS to US. If this change is not made, no data is loaded in the tables.

### 2.5.2.2 Creating a Run

To create a run, do the following:

1. Select `CS_Data_Load_Event_Generation`.
2. Click **Copy**. The Run page appears in Copy Mode.
3. In the Folder field, click the folder icon.
4. Click `TFLSEGMENT`.
5. In the Name field, change the job name to include the Jurisdiction Code. For example, `CS_Data_Load_Event_Generation_US`.
6. Click **Selector >> Job**. The Component Selector page appears.

7. In the Component Selector page, remove the `CS_End_To_End_Start_Batch`, `CS_End_To_End_Start_Batch`, and `Truncate CS Tables` tasks (in that order) by selecting them and clicking . The tasks are moved to the List section.
8. Replace these tasks with the tasks that we have created in step 24 of [Create a process](#). In the above example, the new processing batch name has been changed from `CS` to `US`. If this change is not made, no data is loaded in the tables.

**NOTE**

Ensure that you remove the Truncate CS Tables job, else data will get lost. In the event that you do not move the job, run the `CSBusinessDataLoad` job. This will reload data in the tables

9. Click **OK**.
10. Click **OK**.
11. Click **Save**.

The new job is now displayed in the Run page.

**NOTE**

All the above steps also must be done in the ECM setup. The processes and runs created in Customer Screening create events or alerts, and the processes and runs created in ECM fetches alerts which are converted to events and finally to cases. An example of a process created for ECM is `Oracle_CS_Event_Processing` and an example of a run created for ECM is `Oracle_CS_Event_Processing_US`.

## 2.6 Risk Scoring

Oracle Financial Services Customer Screening includes a mechanism for estimating the relative risk of doing business with a given entity or individual. A risk score is calculated for each individual or entity on each watch list, based on various attributes such as country of residence, operating country, associated regime and so on. For a full description of the risk scores and weightings supplied as defaults with Oracle Financial Services Customer Screening, please refer to Appendix D: Risk scoring reference data.

The risk element score values and weightings supplied with Oracle Financial Services Customer Screening are general defaults only. They should be evaluated and tuned by a risk and compliance expert with knowledge of your business requirements and the relevant legislation.

### 2.6.1 Adjusting the Risk Scoring Mechanism

Oracle Financial Services Customer Screening calculates a risk score and a PEP risk score for every alert created by the screening processes. The risk score is a relative measure, out of a maximum of 100, of the risk posed by the identified individual or entity. The PEP risk score identifies the relative riskiness of the individual or entity when considered as a PEP, and as such does not apply to sanctions. This may be quite different to the non-PEP risk score. Therefore, the same algorithms are used to derive the risk score and PEP risk score, but the underlying scores and weightings on which the calculations are based are different.

**NOTE**

The remainder of this section will use the phrase *risk scores* exclusively. However, the methods and algorithms described apply equally to PEP risk scores.

The overall risk score of a potential match is calculated as a weighted average of the risk scores calculated for the watch list and customer data and external entity records which are involved in the match. In turn, both the watch list risk score and customer data and external entity risk scores are calculated as a weighted average of the risk scores of contributing risk elements. A risk element is a data field, such as country of operation or occupation, which can be assigned a risk score based on its value.

The risk scoring calculation can be customized by adjusting:

1. the scores associated with the values of the risk elements; or
2. the relative weightings of the risk elements; or
3. the relative weight of the watch list risk score, customer data risk score, and external entity risk score.

The reference data tables which must be adjusted to fine-tune the risk scoring mechanism depend on which watch lists you are using in your screening processes.

Alternatively, Oracle Financial Services Customer Screening may be integrated with a third party source of watchlist risk scores which can be used to completely replace the in-process risk score calculation.

## 2.6.2 Adjusting the Risk Element Scores

Risk element scores are adjusted by editing reference data directly. The elements that are considered when calculating a risk score for a record depend on the fields that are present in the watch list (or customer) record.

To edit the risk element values in EDQ, do this:

1. Open the Watchlist Management project.
2. Double-click on the reference data item in the Project Browser.
3. Right-click on the reference data item and select **Edit data**.

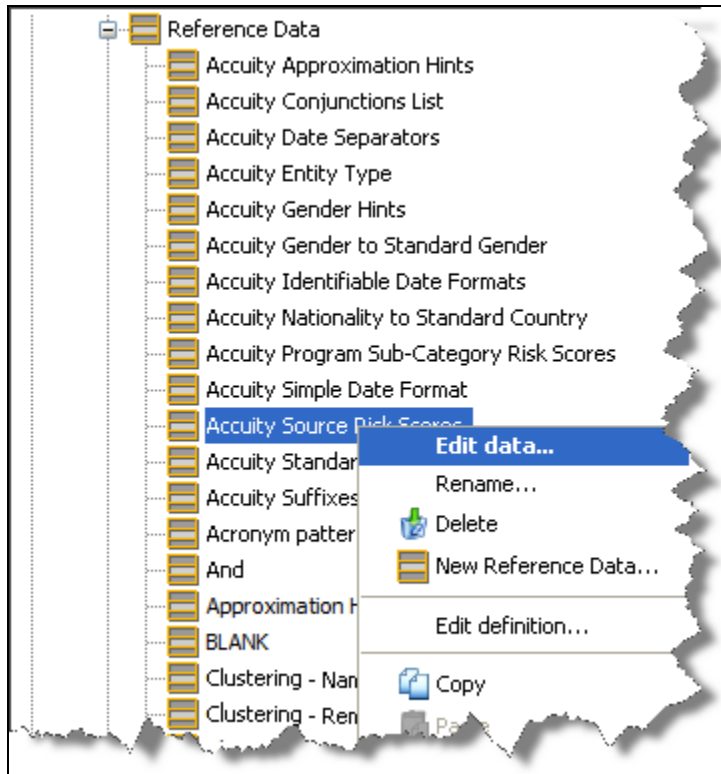

The risk score can then be edited directly in the Reference Data Editor:

Reference Data Editor - Accuity Source Risk Scores

Viewing page 1 of 1 (47 total saved records)

Name	RiskScore	Comment	State	Modified By	Modified On
PEP	25		Active	dnadmin	22-Jul-2010 17:08:47
USP	25		Active	dnadmin	22-Jul-2010 17:08:47
EDI	90		Active	dnadmin	22-Jul-2010 17:08:47
EUL	90		Active	dnadmin	22-Jul-2010 17:08:47
EUA	90		Active	dnadmin	22-Jul-2010 17:08:47
ESA	90		Active	dnadmin	22-Jul-2010 17:08:47
EDA	90		Active	dnadmin	22-Jul-2010 17:08:47
ELK	90		Active	dnadmin	22-Jul-2010 17:08:47
EDC	90		Active	dnadmin	22-Jul-2010 17:08:47
EDE	90		Active	dnadmin	22-Jul-2010 17:08:47
311	75		Active	dnadmin	22-Jul-2010 17:08:47
ACB	75		Active	dnadmin	22-Jul-2010 17:08:47
ARG	75		Active	dnadmin	22-Jul-2010 17:08:47
AUJ	75		Active	dnadmin	22-Jul-2010 17:08:47
BEI	75		Active	dnadmin	22-Jul-2010 17:08:47
BOS	75		Active	dnadmin	22-Jul-2010 17:08:47
BoFE	100		Active	dnadmin	22-Jul-2010 17:08:47
CNA	75		Active	dnadmin	22-Jul-2010 17:08:47
CSL	75		Active	dnadmin	22-Jul-2010 17:08:47
DNB	75		Active	dnadmin	22-Jul-2010 17:08:47
DTC	75		Active	dnadmin	22-Jul-2010 17:08:47
ES	75		Active	dnadmin	22-Jul-2010 17:08:47
EUJ	100		Active	dnadmin	22-Jul-2010 17:08:47
PMU	75		Active	dnadmin	22-Jul-2010 17:08:47
PR	75		Active	dnadmin	22-Jul-2010 17:08:47
HK	75		Active	dnadmin	22-Jul-2010 17:08:47
IA	75		Active	dnadmin	22-Jul-2010 17:08:47
ISN	75		Active	dnadmin	22-Jul-2010 17:08:47
ITL	75		Active	dnadmin	22-Jul-2010 17:08:47
JWF	75		Active	dnadmin	22-Jul-2010 17:08:47
KFT	75		Active	dnadmin	22-Jul-2010 17:08:47

Buttons: Add Row, Add from Clipboard, Remove duplicates, Delete Rows, Delete All Rows, OK, Cancel

**NOTE**

If you edit the risk scores you must re-run the Download, Prepare, Filter and Export All Lists job (in the Watchlist Management project), and then run the MAIN job (in the Watchlist Screening project). Until this is done, the new risk scores will not be reflected in the generated matches.

### 2.6.2.1 Adjusting the Risk Element Weightings

Risk element weightings are controlled in a set of reference data named Risk Element Weightings. This reference data set specifies, for each type of record, which fields in that record contribute to the risk score calculation, and to what degree:

RecordType	ResOpeCo...	NatRegCo...	Membership	Category	Occupation	Deceased	Active	ExternalRisk	Comment
HMT_I	0.2	0.2	0.3	0.3	0	0	0	0	Actri
HMT_E	0.3	0.3	0.3	0.1	0	0	0	0	Actri
OFAC_I	0.2	0.2	0.3	0.3	0	0	0	0	Actri
OFAC_E	0.3	0.3	0.3	0.1	0	0	0	0	Actri
EU_I	0.3	0.3	0.4	0	0	0	0	0	Actri
EU_E	0.3	0.3	0.4	0	0	0	0	0	Actri
UN_I	0.3	0.3	0.3	0.1	0	0	0	0	Actri
UN_E	0.3	0.3	0.3	0.1	0	0	0	0	Actri
WC_I	0.2	0.2	0.3	0.2	0	0.1	0	0	Actri
WC_E	0.3	0.3	0.3	0.1	0	0	0	0	Actri
WC_PEP_I	0.2	0.2	0.3	0	0	0.3	0	0	Actri
WC_PEP_E	0.3	0.3	0.4	0	0	0	0	0	Actri
DJW_I	0.2	0.2	0.2	0.1	0.1	0.1	0.1	0	Actri
DJW_E	0.2	0.2	0.3	0.1	0	0	0.2	0	Actri
DJW_PEP_I	0.2	0.2	0.2	0.1	0.1	0.1	0.1	0	Actri
CUST_I	0.5	0.5	0	0	0	0	0	0	Actri
CUST_E	0.5	0.5	0	0	0	0	0	0	Actri
Accuity_I	0.2	0.2	0.3	0.3	0	0	0	0	Actri
Accuity_E	0.3	0.3	0.3	0.1	0	0	0	0	Actri
Accuity_PEP_I	0.2	0.2	0.3	0.3	0	0	0	0	Actri
Accuity_PEP_E	0.3	0.3	0.3	0.1	0	0	0	0	Actri
PRIV_I	0.5	0.5	0	0	0	0	0	0	Actri
PRIV_E	0.5	0.5	0	0	0	0	0	0	Actri
PRIV_PEP_I	0.5	0.5	0	0	0	0	0	0	Actri
PRIV_PEP_E	0.5	0.5	0	0	0	0	0	0	Actri
DJAC_I	0.2	0.2	0.2	0.1	0.1	0.1	0.1	0	Actri
DJAC_PEP_I	0.2	0.2	0.2	0.1	0.1	0.1	0.1	0	Actri
DJAC_E	0.2	0.2	0.3	0.1	0	0	0.2	0	Actri
DJAC_PEP_E	0.3	0.3	0.4	0	0	0	0	0	Actri

Record types are specified as a combination of the originating watch list and a suffix specifying whether the record represents an individual (\_I), or an entity (\_E). Working records have a record type of CUST\_I or CUST\_E, respectively.

The ResOpeCountries column specifies the weighting for the Residential Country field for individuals, or the Operating Country field for entities. The NatRegCountries column specifies the weighting for the Nationality Country field for individuals, or the Registrations Country field for entities.

This reference data, which is in the Watchlist Management project, can be edited as described above. The higher the weighting number, the more the corresponding element will contribute to the final score. The weighting scores for each row type should add up to 1.

The overall risk score calculation for a record containing n elements is therefore as follows:

$$\text{Risk Score} = E1w1 + E2w2 + \dots + Enwn$$



Where the risk element score for element  $x$  is represented by  $E_x$ , the weighting for element  $x$  is represented by  $w_x$ , and  $(w_1 + w_2 + \dots + w_n = 1)$ .

**NOTE**

If no data is present for a given element, it is not assumed to have a risk score of zero, but instead will not be included in the risk score calculation.

### 2.6.2.2 Setting Thresholds for Case Priorities

Case priority is based on the case type and risk score. You can see the case priority in the `FCC_CASE_PRIORITY` table. For more information, refer to the [Oracle Financial Services Enterprise Case Management Administration Guide](#).

## 2.7 Configurations for GDPR

The following configurations need to be made for GDPR:

1. Create a user who will do the GDPR configurations in the same database, for example, `GDPR`.
2. Assign the `OFS_NOSEC_DATA` privilege to the user by executing the following grant:
3. `GRANT OFS_NOSEC_DATA to GDPR.`

**NOTE**

Before you execute the grant, you must first connect to the user. To do this:

1. Create a synonym called `cs_customer` for the user by executing the following command:

```
CREATE PUBLIC SYNONYM cs_customer FOR  
{dbname}.cs_customer;
```

`{dbname}` is the user who has the cust data and GDPR applied.

2. In the Project Browser pane in EDQ, click **FCCM Batch Data**. The Edit Data Source window appears.
3. In the Edit Data Source window, give the details of the user.

Once you complete the above steps, you will be able to access the complete data in the `CUST` table.

# 3 Preparing Customer and External Entity Data for Screening

The sections in this chapter describe the steps needed to prepare the customer data and external entity data for Oracle Financial Services Customer Screening.

## 3.1 Real-Time Screening

Real-time screening is deployed in conjunction with a back-office batch screening approach, allowing the business to screen individuals and entities at the point of data acquisition and on an ongoing basis.

The below image gives the flow of Real-time screening:

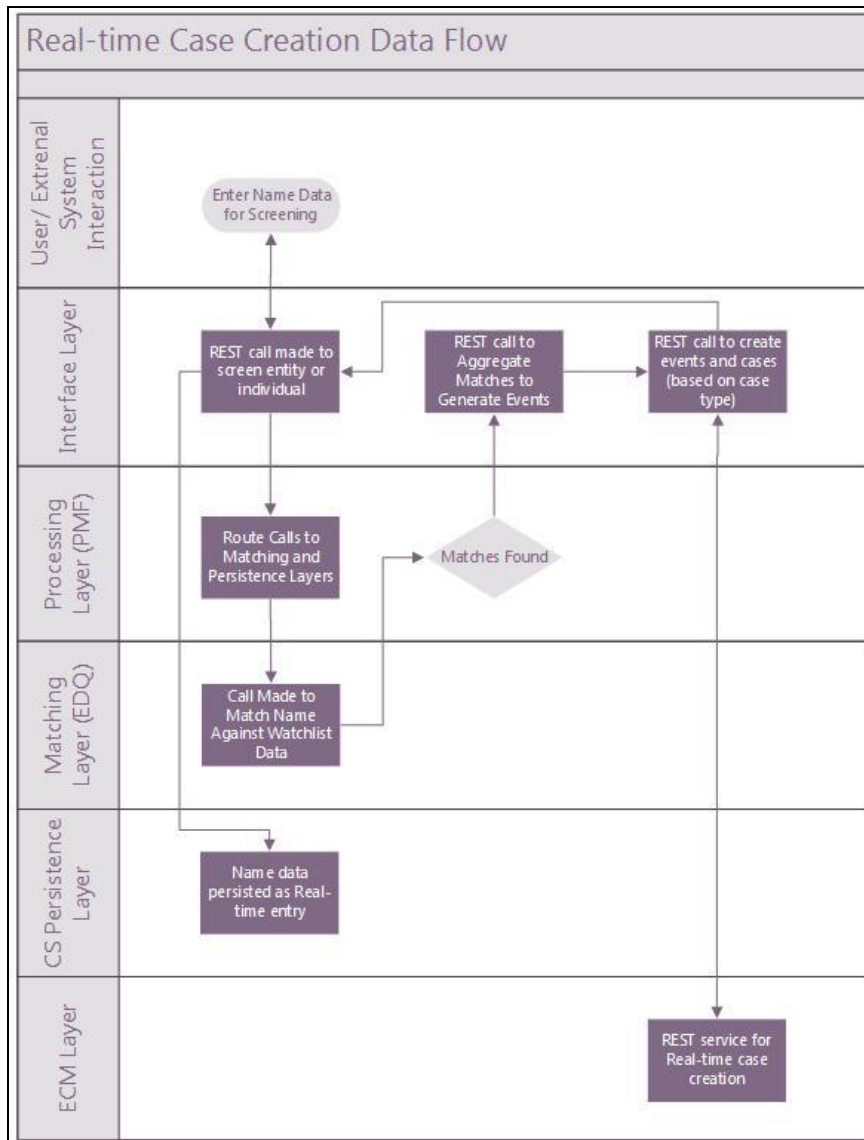

There are two ways to perform real-time screening: using the Real-Time Screening page in Customer Screening (CS) or by making a REST call.

When you provide data in the Real-Time Screening page (see section below), a REST call is made to the individual or entity being screened in the Process Modelling Framework (PMF) system. The call is then routed to the Enterprise Data Quality (EDQ) system, and

data is matched against the watch list data. Data is also persisted as external entities in the FCT\_RTSCR\_REQUEST table.

If a match is found, matches are aggregated, and events and responses are generated in PMF. The aggregated matches are used to create events and cases for external entities in FCDM and AAI and generate responses in PMF. The cases are displayed in the Case Summary page in Enterprise Case Management (ECM) and can be reviewed.

**NOTE**

1. Real-time screening can be performed only when the real-time screening job in EDQ is running.
2. If you need to cancel either of the real-time screening processes for any reason other than as part of a scheduled job, it is important that you select **Shutdown web services** in the *Cancel Individual Real-time Screening web services* dialog box.
3. The Real-time access group must only be mapped to the case supervisor or the case analyst users, and must not be mapped to the admin user.

### 3.2 Screening Watch list Records in Real Time

To screen watch list records, do the following:

1. Log on to the Customer Screening application.
2. Click **Real-Time Screening**. The Real-Time Screening page appears.

3. Select the search type as **Individual** or **Entity**.
4. Enter the Jurisdiction, Family Name, Given Name, and Business Domain for the Individual search type, and the Jurisdiction, Entity Name, and Business Domain for the Entity search type. You can also provide additional details such as the Address Country, City, External ID Type, and External ID.

There are some additional fields specific to only the Individual search type, such as the Country of Birth, Date of Birth, Residency Country, and Nationalities. There are also some additional fields specific to only the Entity search type, such as the Operating Countries and Registration Country.

5. Click **Scan**. The screened watch list records appear.

Select the search type:  Individual  Entity

Given Names: Robert  
 Family Names: Mugabe  
 Original Script Name:   
 Date of Birth: mm/dd/yy

Jurisdiction \*: Americas  
 Business Domain \*: GEN  
 City:   
 Address Country:   
 Residency Country:   
 Nationalities:   
 Country of Birth:   
 External ID Type:   
 External ID:   
 Scan Clear

1 Cases created with 1 events

Case ID : CA383 | Record Type: SAN

List Key	Name Type	Primary Name	Full Name	Original Script Name	Watchlist ID	Match Rule	Match Score	Country	Nationality
EU	Primary	ROBERT GABRIEL MUGABE	ROBERT GABRIEL MUGABE		1	(I0600) Abbreviated standardized given name only	81		

Page 1 of 1 (1 of 1 items)

### 3.3 Configuring the EDQ URL

To configure the EDQ URL for Real-time screening, do the following:

1. Navigate to FCI\_DB\_HOME/bin.
2. Execute EDQInsert.sh by passing the infodom. This step is used to register the EDQ server details. Enter the EDQ server IP, Port number, user name and password details.

For example, ./EDQInsert.sh SANCTIONSINFO

```

/scratch/ofsaadb/PACK806BS/PACK806BS/ficdb/bin>./EDQInsert.sh BDPACKINFO
Started finding Jars
Ended finding Jars
Classpath Created
Calling EDQ Main Method
Inside EDQ insert method
Enter EDQ Server IP:
10.184.158.232
Enter EDQ Server Director Port:
8090
Enter EDQ Server User Name:
weblogic
Enter EDQ Password:
Encrypting password
Enter ECM URL:
https://mum00ctf.in.oracle.com:7501/BDPACK
Enter ECM User Name:
ECMADMN
Enter ECM Password:
Encrypting password
    
```

3. Configure the EDQ URL in config schema. To do this, run the following script and replace the placeholders in the v\_method\_name and v\_param\_1 columns with your EDQ URL and EDQ user name and password respectively:

```

select t.*,t.rowid from aai_wf_application_api_b t where
t.v_process_id='CSRT' and t.v_app_api_id in
('1521535704140','1521535760435');
    
```

For example. The placeholder for the EDQ URL may be <http://whf00bte.in.oracle.com:7008/edq>. You must replace this with the URL of your EDQ server.

**NOTE**

The placeholders for the EDQ user name and password may be weblogic and weblogic1. You must replace this with the user name and password of your EDQ server.

## 3.4 Batch Screening from Financial Services Crime Model (FCDM)

### 3.4.1 Staging Database Connection Details

In order to be able to run the Customer Screening jobs using FCDM as source of customer data and external entity data, you need to tell EDQ about the connection details of the staging database into which FCDM will place the Customer Information to be screened.

Database parameters have to be set in Data Stores. To set the parameters, follow these steps:

- For Customer Screening:
  - a. Open **Director**.
  - b. Select the **Customer-Screening** project.
  - c. In Data stores, open **FCDM Batch Data**.
  - d. Edit and enter the data base details.

The screenshot shows the 'Edit Data Store' dialog box. The title bar reads 'Edit Data Store'. The main area is titled 'Oracle Configuration' and contains the following fields:

- Database host: Local Host
- Port: 1521
- Database name: Database Name
- Name type: SID (dropdown menu)
- User name: User Name
- Password: (empty text box)
- Schema: (empty text box)

Below the fields is a note: 'The schema need not be entered if it is the default for the user'. At the bottom right of the configuration area is a 'Test...' button. At the bottom right of the dialog box are 'OK' and 'Cancel' buttons.

- For External Entity Screening:
  - a. Open Director.
  - b. Select the Customer-Screening project.
  - c. In Data stores, open FCDM Batch Data.
  - d. Edit and enter the data base details.

**NOTE**

Your OEDQ instance's config folder might not be named *config*. The choice of the config folder's name is made when OEDQ is installed - in some cases a name is automatically allocated. OEDQ release 11g and later has both a *base* and a *local* config folder. The base config folder is often called *oedqhome*, and the local config folder is often called *oedqlocalhome*. In some cases, dots or underscores may be inserted into these names (For example, *oedq\_local\_home*). Whenever you see a file path in this document that begins with *config*, this always refers to your OEDQ instance's local config folder.

- Amend the parameter values so that they reflect the connection details of your staging database. For example, in the top line, replace hostname with the name or IP address of the machine that hosts your staging database.

**NOTE**

1. It is not necessary to enter the schema if the user you input is the schema owner.
2. The parameters can be passed as externalized values in the `runopsjob` command.

## 3.5 FCDM System Name

The FCDM Integration section of the `customer-screening.properties` Run Profile contains the following parameters:

```
phase.Batch\ Screening\ FCDM.enabled = Y
phase.Snapshot\ External\ Entity\ Data.enabled = N
```

The FCDM Integration section of the `external.entity.properties` Run Profile contains the following parameter:

```
phase.Snapshot\ External\ Entity\ Data.enabled = Y
```

You can optionally amend this parameter's value to a value of your choice. Whatever value you associate with this parameter is presented to reviewers as the List Sub Key in Enterprise Case Management.

## 3.6 FCDM Data Preparation

There is a FCDM specific data preparation process which needs to be run prior to the standard Customer Entities Preparation and Customer Individuals Preparation Process. This process performs a number of transformations:

1. Splits records into individuals and entities based on Customer Type Code
2. Creates additional rows of data for aliases
3. Creates name attributes compatible with CDI
4. Derives gender and year of birth for individuals

**NOTE**

The FCDM Data Preparation job is built on expected population of data in FCDM. This needs to be validated for each specific implementation and the process adapted if needs be.

### 3.6.1 Analyzing Customer Data and External Entity Data Quality

Oracle Financial Services Customer Screening is supplied with a process which checks the appropriateness of data in FCDM for screening. This process can be run independently of the screening process, and identifies potential issues with the customer data and external entity data quality which may affect the efficiency of screening.

#### 3.6.1.1 Running the Data Quality Analysis

To analyze your working customer data and external entity data:

1. Ensure that your working data has been loaded into FCDM and the customer-screening project has the correct database parameters.
2. Run the Analyze FCDM Customer Data Quality job.

**NOTE**

The Analyze FCDM Customer Data Quality job needs to be run with the FCDM version along with the customer-screening.properties file to get customer data and external-entity-screening.properties file to get external entity data.

The job checks your customer data for any quality issues that may have a negative impact on the screening process. The results of the quality analysis are written as staged data and can be viewed using the Server Console UI.

#### 3.6.1.2 Data Quality Errors

The error codes and the associated messages that can be raised by the customer data and external entity data quality analysis are listed in the CDI Error Codes reference data. Each error message is assigned an error severity, from 1 to 4, which corresponds to the likely impact the issue will have on screening efficiency. The error severities are as follows:

Severity code	Description
1	Severe data error which prevents screening.
2	Invalid data which will limit the effectiveness of screening.
3	Missing data which will limit the effectiveness of screening.

Severity code	Description
4	Invalid data which has no effect on screening. Errors in this category will not affect the output of the match processor, but may cause issues when manually evaluating any potential matches that are raised.

Please refer to the Oracle Financial Services Customer Screening Customer Data Interface Guide for a more complete description of the data quality checks and potential validation errors.

Any rows in your customer data and external entity data which cause a severity 1 error message to be raised will also be rejected by the screening process. These rows lack data in the core attributes used by the screening process, and so cannot be processed meaningfully.

The screening processes will output rows which cannot be screened into the CUST\_Individuals\_Invalid staged data or the CUST\_Entities\_Invalid staged data, as appropriate. The error codes associated with each row will also be written to the database.

### 3.6.2 ETL Database Connection Details

After screening has run relationships (matches) and watchlist records are exported to the Customer Screening database for further processing and publishing to ECM.

Database parameters are set in *ECM Matches Output* under the *Data stores* in the *Customer-Screening* project.

Ensure that the following parameters are present, and add them if they are not:

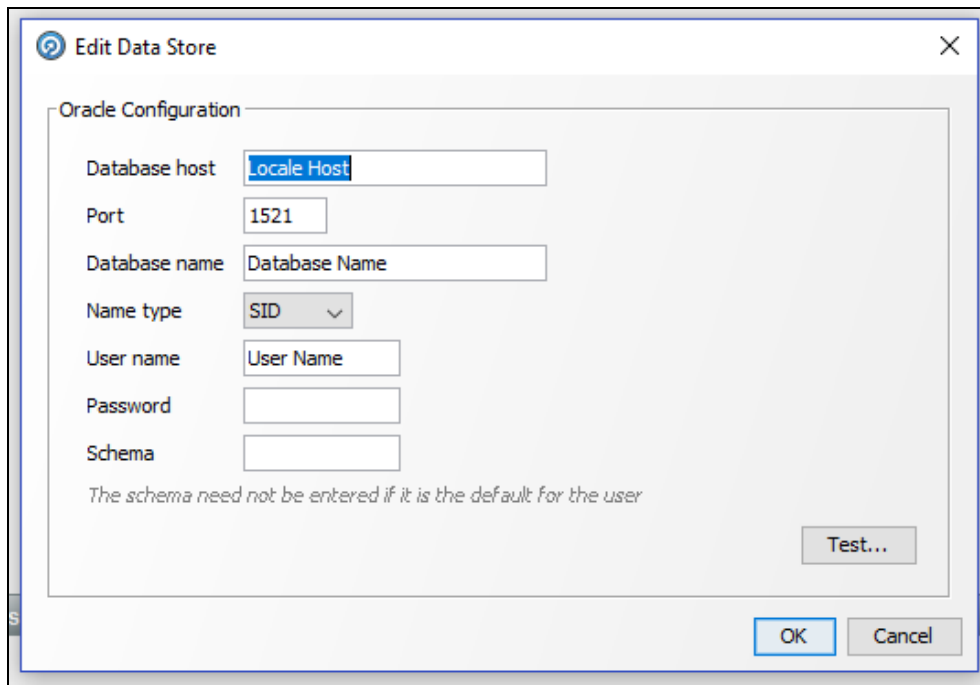



**NOTE**

3. It is not necessary to enter the schema if the user you input is the schema owner.
4. The parameters can be passed as externalized values in the runopsjob command.

### 3.6.3 Batch Screening Job

To source the data from FCDM and run the FCDM data preparation process, the MAIN batch screening job phase needs to be disabled and the FCDM version enabled in the customer screening.properties and external-entity.properties Run Profiles:

```
# Globally turns on/off batch screening types
phase.Batch\ Screening.enabled = N
phase.Batch\ Screening\ FCDM.enabled = Y
```

To export the data to the Customer Screening database these job phases also need to be enabled.

```
phase.ECM\ Export\ Matches.enabled = Y
phase.ECM\ Export\ Watchlist.enabled = Y
```

### 3.6.4 Real-Time Screening Job

To source the data from FCDM and run the FCDM data preparation process, the MAIN\_RT real-time screening job phase needs to be disabled and the FCDM version enabled in the customer screening-real-time.properties and external-entity.properties Run Profiles:

```
phase.Start\ Real-time\ Screening.enabled = Y

# Control single real-time screening types
phase.Real-time\ Screening.process.Individual\ Real-time\
Screening.san_enabled = Y
phase.Real-time\ Screening.process.Individual\ Real-time\
Screening.pep_enabled = Y
phase.Real-time\ Screening.process.Individual\ Real-time\
Screening.edd_enabled = Y

phase.Real-time\ Screening.process.Entity\ Real-time\
Screening.san_enabled = Y
phase.Real-time\ Screening.process.Entity\ Real-time\
Screening.pep_enabled = Y
phase.Real-time\ Screening.process.Entity\ Real-time\
Screening.edd_enabled = Y
```

## 4 Workflow Diagrams

The following diagrams represent the workflow:

### 4.1 SAN and PRB Workflow

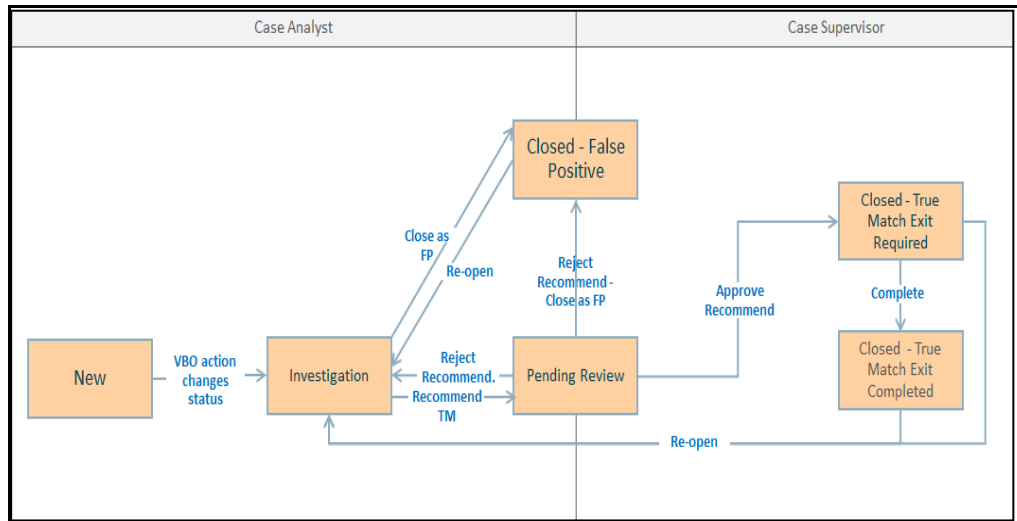

### 4.2 PEP and EDD Workflow

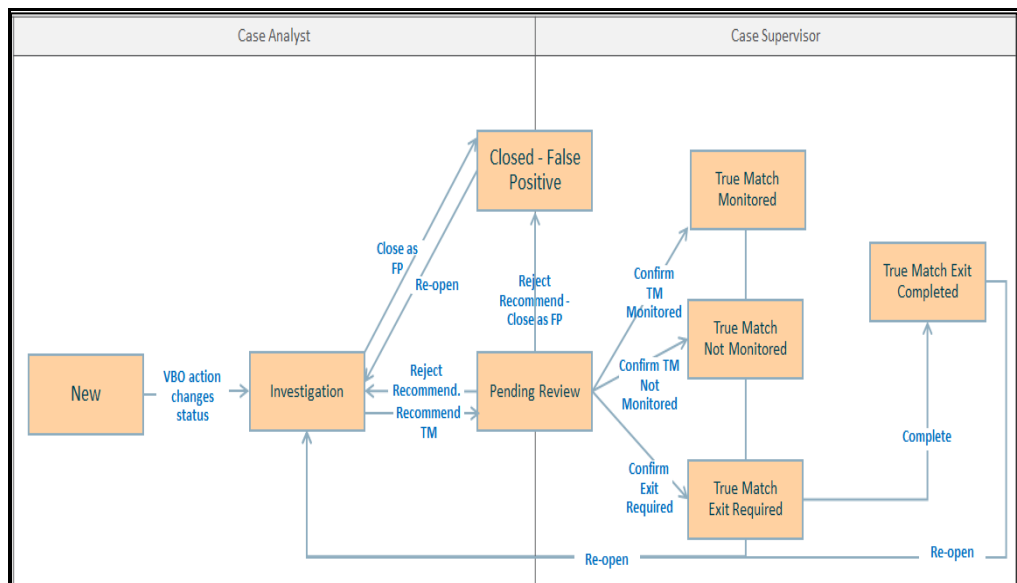

## 5 Appendix A: Screening Non-Latin Character Sets

The reference data sources supported by Oracle Financial Services Customer Screening are all provided in the Latin character set, and some in original scripts as well. The screening processes can be used with non-Latin data if required. In addition, Oracle can provide linguistic name matching and culture derivation by integration with IBM's Global Name Recognition product.

Non-Latin working data can be screened against the existing supported Latin reference data sources by performing transliteration of the working data from the non-Latin character set to the Latin character set.

Non-Latin working data can be screened against non-Latin reference data without any changes to the product although certain fuzzy text matching algorithms may not be as effective in the non-Latin character set. Text will be processed on a left-to-right basis.

### NOTE

It may be necessary to install additional language packs in order to display non-Latin data.

The screenshot below shows the transliteration of Cyrillic to the Latin character set:

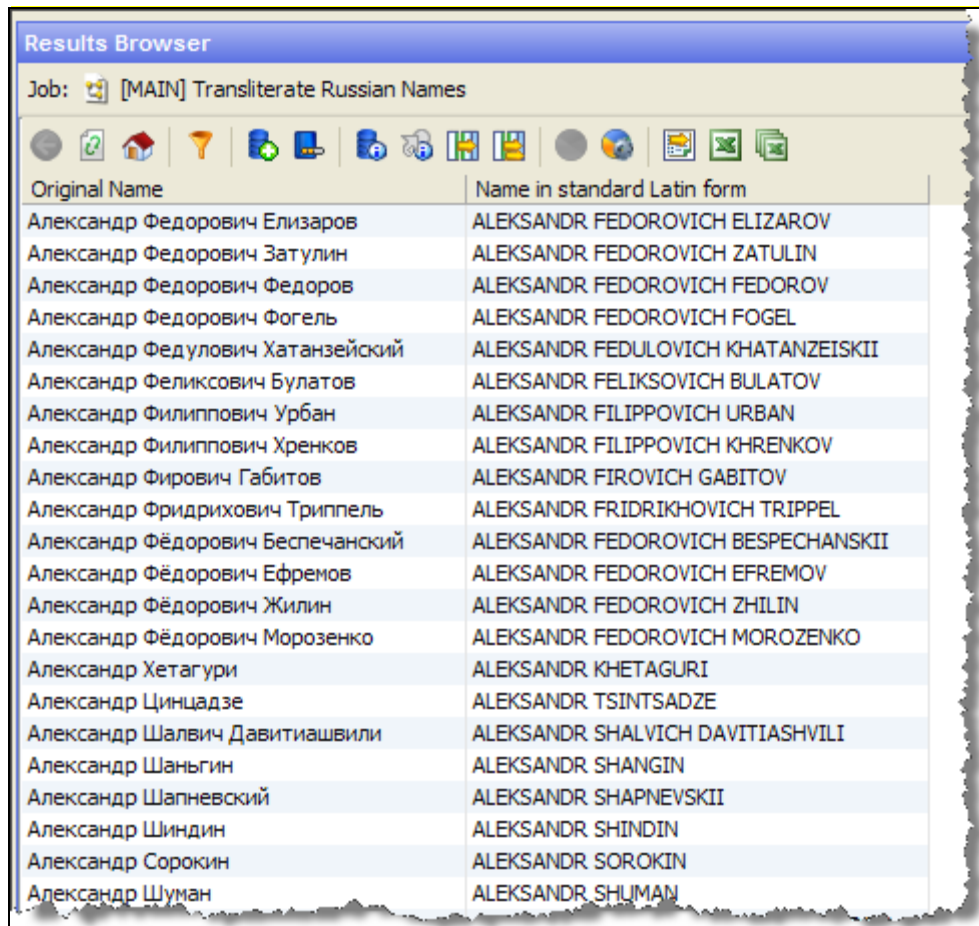

Original Name	Name in standard Latin form
Александр Федорович Елизаров	ALEKSANDR FEDOROVICH ELIZAROV
Александр Федорович Затулин	ALEKSANDR FEDOROVICH ZATULIN
Александр Федорович Федоров	ALEKSANDR FEDOROVICH FEDOROV
Александр Федорович Фогель	ALEKSANDR FEDOROVICH FOGEL
Александр Федулович Хатанзейский	ALEKSANDR FEDULOVICH KHATANZEISKII
Александр Феликсович Булатов	ALEKSANDR FELIKSOVICH BULATOV
Александр Филиппович Урбан	ALEKSANDR FILIPPOVICH URBAN
Александр Филиппович Хренков	ALEKSANDR FILIPPOVICH KHRENKOV
Александр Фирович Габитов	ALEKSANDR FIROVICH GABITOV
Александр Фридрихович Триппель	ALEKSANDR FRIDRIKHOVICH TRIPPEL
Александр Фёдорович Беспечанский	ALEKSANDR FEDOROVICH BESPECHANSKII
Александр Фёдорович Ефремов	ALEKSANDR FEDOROVICH EFREMOV
Александр Фёдорович Жилин	ALEKSANDR FEDOROVICH ZHILIN
Александр Фёдорович Морозенко	ALEKSANDR FEDOROVICH MOROZENKO
Александр Хетагури	ALEKSANDR KHETAGURI
Александр Цинцадзе	ALEKSANDR TSINTSADZE
Александр Шалвич Давитиашвили	ALEKSANDR SHALVICH DAVITIASHVILI
Александр Шаньгин	ALEKSANDR SHANGIN
Александр Шапневский	ALEKSANDR SHAPNEVSKII
Александр Шиндин	ALEKSANDR SHINDIN
Александр Сорокин	ALEKSANDR SOROKIN
Александр Шуман	ALEKSANDR SHUMAN

---

### 5.1.1.1 Original Script Matching

To match original script data against reference data:

1. Prepare customer data and external entity data such that non-Latin names are populated in the Original Script Name fields of the Customer Data interface; and
2. Enable Original Script Name match rules and clusters.

For further details on preparing customer data and external entity data and to enable match rules, see the [Customer Data Interface and Matching Guides](#).

---

**NOTE**

Changes will be required to the FCDM Customer Preparation process to support this.

---

## 6 Appendix B: Risk Scoring Reference Data

This appendix lists the reference data tables supplied with Oracle Financial Services Customer Screening which contain data used to calculate risk scores and PEP risk scores. You can find these reference data tables in the Watchlist Management project.

### 6.1 General

The following reference data table contains risk score values used by multiple screening processes:

Risk - ISO 3166-1 Country to Risk Score (used by the lookup Risk - ISO 3166-1-alpha-2 code to Risk Score) is used to derive a risk score from a country code.

### 6.2 Country Prohibitions

The following reference data tables contain risk score values used in country prohibition screening processes:

- Country Prohibitions - Entities
- Country Prohibitions - Individuals

### 6.3 Dow Jones Watchlist

The following reference data tables contain risk score values used when calculating risk scores for the Dow Jones Watchlist records:

- DJW Occupation Category
- DJW List Provider Risk Scores
- DJW SI Category Description
- DJW SI Category

### 6.4 Dow Jones Anti-Corruption List

The following reference data tables contain risk score values used when calculating risk scores for the Dow Jones Watchlist records:

- DJAC Occupation Category
- DJAC List Provider Risk Scores
- DJAC SI Category Description

### 6.5 EU Reference Data

There are no reference data tables containing risk score values used only for calculating risk scores for the EU reference data records.

## 6.6 HM Treasury Reference Data

The following reference data table contains risk score values used when calculating risk scores for the HM Treasury Reference Data records:

- HMT Regime

## 6.7 OFAC Reference Data

The following reference data table contains risk score values used when calculating risk scores for the OFAC Reference Data records:

- OFAC SDN Program

## 6.8 UN Reference Data

The following reference data table contains risk score values used when calculating risk scores for the UN Reference Data records:

- UN List Type

## 6.9 World-Check Reference Data

The following reference data tables contain risk score values used when calculating risk scores for the World-Check Watchlist records:

- WC Category
- WC Keyword (used by the lookup WC Keyword - Risk Score Lookup)

## 6.10 Accuity Reference Data

The following reference data tables contain risk score values used when calculating risk scores for the Accuity Reference Data records:

- Accuity Program Sub-Category Risk Scores
- Accuity Source Risk Scores

## 6.11 Risk Element Weightings

The following reference data table contains the weightings used when calculating a record risk score from the various contributing elements:

- Risk – Risk Element Weighting

---

## 7 Appendix C: Pre-Configured Watch List Information

This appendix contains details of each of the pre-configured watch lists that can be used by Oracle Financial Services Customer Screening.

### 7.1 HM Treasury Reference Data

The HM Treasury publishes a sanctions list that can be used for screening in Oracle Financial Services Customer Screening. The sanctions list provides a consolidated list of targets listed by the United Nations, European Union and United Kingdom under legislation relating to current financial sanctions regimes.

The HM Treasury website provides more details about the list at:

<https://www.gov.uk/government/publications/financial-sanctions-consolidated-list-of-targets>

Oracle Financial Services Customer Screening uses the list in a semi-colon delimited form. It can be downloaded from:

<https://ofsistorage.blob.core.windows.net/publishlive/ConList.csv>

### 7.2 OFAC Reference Data

The US Treasury website states: *The US Treasury's Office of Foreign Assets Control (OFAC) administers and enforces economic and trade sanctions based on US foreign policy and national security goals against targeted foreign countries, terrorists, international narcotics traffickers, and those engaged in activities related to the proliferation of weapons of mass destruction.* More details on the OFAC list can be found on the US Treasury website, at:

<http://www.treasury.gov/ofac/>

Oracle Financial Services Customer Screening supports two lists that are produced by OFAC:

- The OFAC Specially Designated Nationals (SDN) list, which is available for download in three separate parts from the following links:

<https://www.treasury.gov/ofac/downloads/sdn.csv>

<https://www.treasury.gov/ofac/downloads/add.csv>

<https://www.treasury.gov/ofac/downloads/alt.csv>

- The OFAC Consolidated Sanctions List, which can be downloaded in three separate parts from the following links:

[https://www.treasury.gov/ofac/downloads/consolidated/cons\\_prim.csv](https://www.treasury.gov/ofac/downloads/consolidated/cons_prim.csv)

[https://www.treasury.gov/ofac/downloads/consolidated/cons\\_add.csv](https://www.treasury.gov/ofac/downloads/consolidated/cons_add.csv)

[https://www.treasury.gov/ofac/downloads/consolidated/cons\\_alt.csv](https://www.treasury.gov/ofac/downloads/consolidated/cons_alt.csv)

## 7.3 EU Reference Data

The European Union applies sanctions or restrictive measures in pursuit of the specific objectives of the Common Foreign and Security Policy (CFSP) as set out in Article 11 of the Treaty on European Union.

The European Commission offers a consolidated list containing the names and identification details of all persons, groups and entities targeted by these financial restrictions. See the European Commission website for more details:

[http://eeas.europa.eu/cfsp/sanctions/index\\_en.htm](http://eeas.europa.eu/cfsp/sanctions/index_en.htm)

To download the consolidated list:

1. Go to <https://webgate.ec.europa.eu/europeaid/fsd/fsf#!/account> and create a user name and password to the site.
2. Navigate to <https://webgate.ec.europa.eu/europeaid/fsd/fsf#!/files> and open show settings for crawler/robot.
3. Copy the URL for 1.0 XML (Based on XSD). This will be in the format [https://webgate.ec.europa.eu/europeaid/fsd/fsf/public/files/xmlFullSanctionsList/content?token=\[username\]](https://webgate.ec.europa.eu/europeaid/fsd/fsf/public/files/xmlFullSanctionsList/content?token=[username]). You must replace the [username] placeholder with the user name you have created.
4. Enter this URL in your run profile or download task.

## 7.4 UN Reference Data

The United Nations consolidated list includes all individuals and entities subject to sanctions measures imposed by the Security Council.

Details are here: <https://www.un.org/sc/suborg/en/sanctions/un-sc-consolidated-list>

Download link is:

<https://www.un.org/sc/suborg/sites/www.un.org.sc.suborg/files/consolidated.xml>

## 7.5 World-Check Reference Data

World-Check provides a subscription based service, offering a consolidated list of PEPs (Politically Exposed Persons) and entities and individuals appearing on the HM Treasury, OFAC, and other world lists. Three levels of subscription are provided: Standard, Premium and Premium+. Some features of the World-Check lists are only available to users with a higher subscription level.

To download the World-Check Premium+ feed, set values in the *WC Setup* section of the `watchlist-management.properties` Run Profile as follows:

```
phase.WC\ -\ Download.enabled = Y
phase.WC\ -\ Download\ native\ aliases.enabled = Y
phase.WC\ -\ Stage\ reference\ lists.enabled = Y
phase.*.process.*.use_accelus_url = Y
```

To download the Standard or Premium feeds, set values in the *WC Setup* section of the `watchlist-management.properties` Run Profile as follows:

```
phase.WC\ -\ Download.enabled = Y
```



```
phase.WC\ -\ Download\ native\ aliases.enabled = N
phase.WC\ -\ Stage\ reference\ lists.enabled = Y
phase.*.process.*.use_accelus_url = Y
```

When the parameter is set to Y, content from the following URL is displayed:

<https://app.accelus.com/#accelus/fsp/%7B%22location%22%3A%22%3Flocale%3Den-US%23fsp%2Fquickid%2F>

When the parameter is set to N, content from the following URL is displayed:

<https://www.world-check.com/frontend/profile/>

See the World-Check website for more details:

<https://risk.thomsonreuters.com/en/products/third-party-risk/world-check-know-your-customer.html>

#### NOTE

If your instance of Oracle Financial Services Customer Screening uses the WebLogic application server, and you are screening against the World-Check watch list, then, in order to download the World-Check reference data successfully, you must add the following to the *Server Start* arguments of your EDQ managed server:

```
-DUseSunHttpHandler=true
```

This is only required if you are using the WebLogic application server and screening against the World-Check watch list.

## 7.6 Dow Jones Watchlist Reference Data

Dow Jones provide a subscription based service offering a consolidated list of PEPs (Politically Exposed Persons) and entities and individuals appearing on the various sanctions lists. See the Dow Jones website for more details:

<https://www.dowjones.com/products/risk-compliance/>

The Dow Jones Watchlist automated download task uses one of two script files that are provided with Oracle Financial Services Customer Screening to provide further configuration of the download process. These script files are:

- `download-djw.sh` (for use on Unix platforms)
- `download-djw.bat` (for use on Windows platforms)

The script files are invoked by the automated task and will download the data files and copy them to the appropriate sub-folder of the OEDQ landing area. The script files must be modified to provide the appropriate download URL and any required proxy server details for your Internet connection, as detailed in the following procedure:

1. Open the **External Tasks** node for your List Management project in the project browser, and double click on the **Download Dow Jones Watchlist** task.

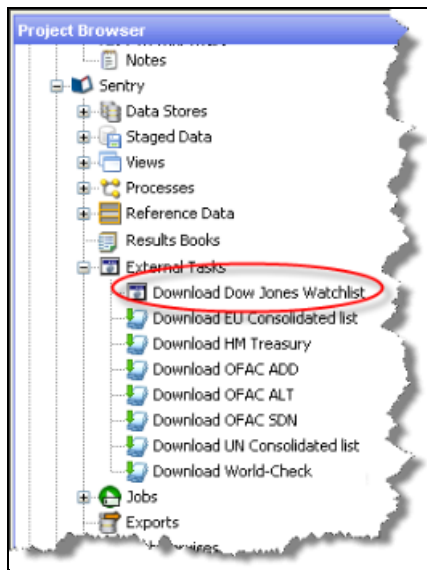

2. Configure the external task to call the batch or shell file, as appropriate, that is in use for your installation:

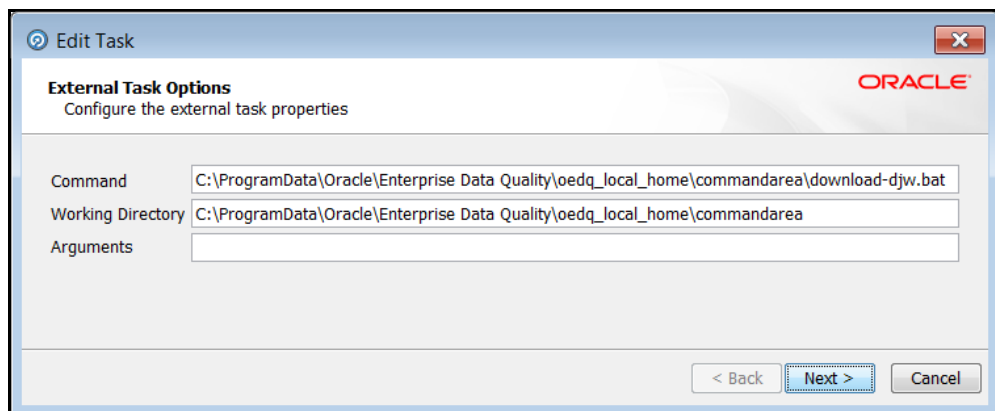

3. Configure your PATH system variable to include the path to your Java installation. The external file invokes Java directly, so the PATH must be configured appropriately.
4. Finally, edit your batch or script file to include your Dow Jones authentication information and any proxy server configuration details that are applicable.

## 7.7 Dow Jones Anti-Corruption List Reference Data

Dow Jones provide a subscription based service containing data to help you assess, investigate and monitor third-party risk with regard to anti-corruption compliance regulation. See the Dow Jones website for more details:

<https://www.dowjones.com/products/risk-compliance/>

The Dow Jones Anti-Corruption List automated download task uses one of two script files that are provided with Oracle Financial Services Customer Screening to provide further configuration of the download process. These script files are:

- `download-djac.sh` (for use on Unix platforms)

- `download-djac.bat` (for use on Windows platforms)

The script files are invoked by the automated task and will download the data files and copy them to the appropriate sub-folder of the OEDQ landing area. The script files must be modified to provide the appropriate download URL and any required proxy server details for your Internet connection, as detailed in the following procedure:

1. Open the External Tasks node for your Watchlist Management project in the project browser, and double click on the **Download Dow Jones Anti-Corruption List** task.

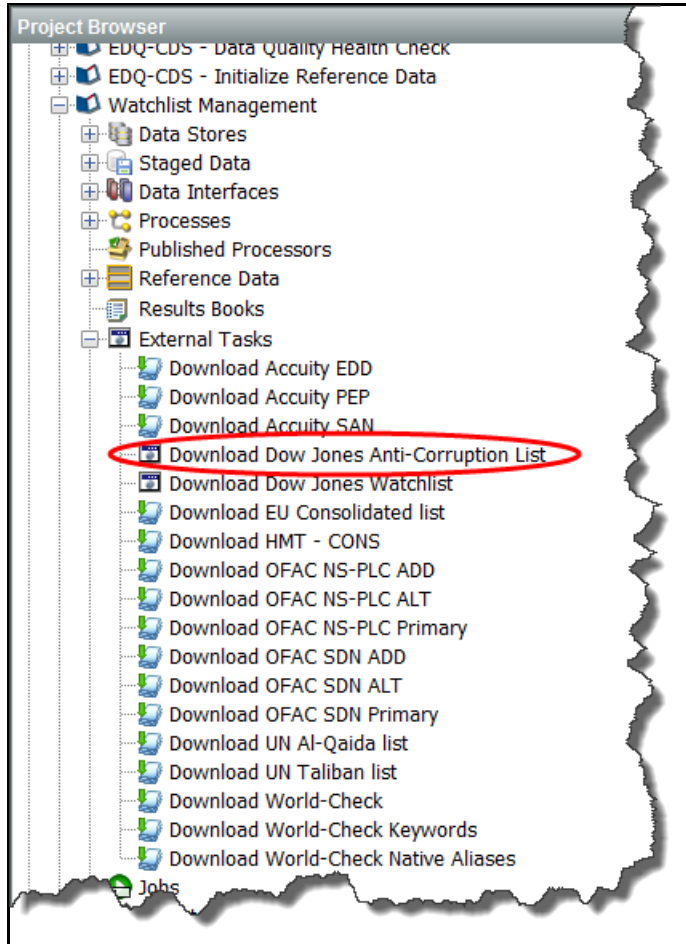

2. Configure the external task to call the batch or shell file, as appropriate, that is in use for your installation:

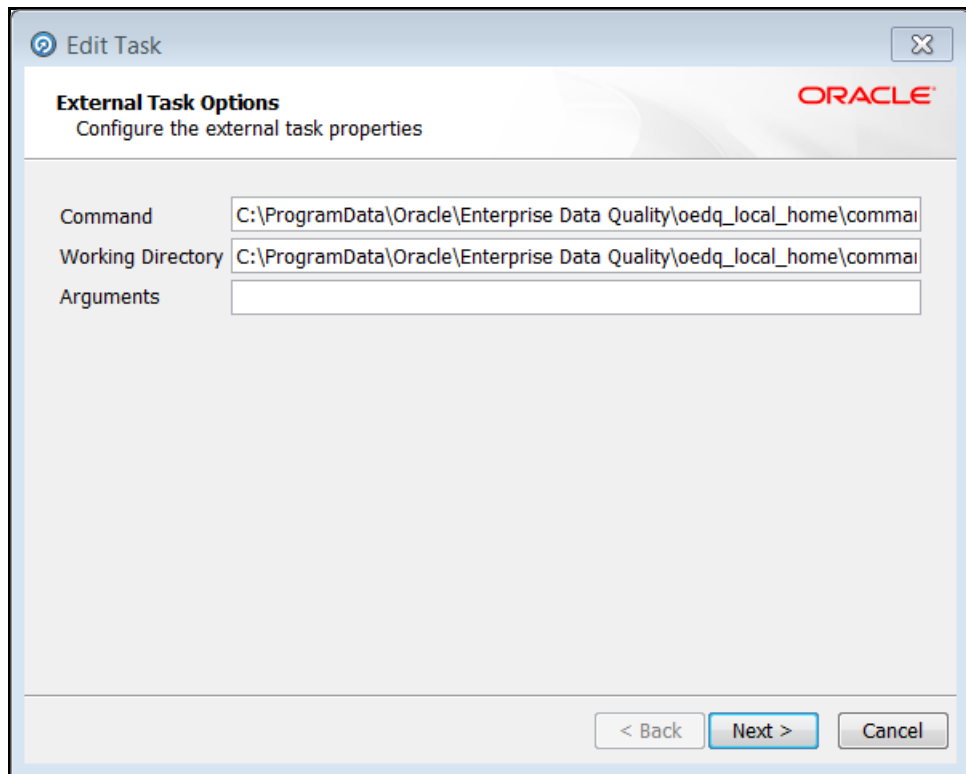

3. Configure your PATH system variable to include the path to your Java installation. The external file invokes Java directly, so the PATH must be configured appropriately.
4. Finally, edit your batch or script file to include your Dow Jones Anti-Corruption List authentication information and any proxy server configuration details that are applicable.

## 7.8 Accuity Reference Data

The Accuity Global Watchlist is a subscription based service. The Accuity website states:

*Accuity's proprietary collection of watch list screening databases is an aggregation of specially designated individuals and entities compiled from dozens of regulatory and enhanced due diligence lists from around the world. Global WatchList provides the ideal framework for your customer screening and interdiction filtering processes.*

Accuity provide their aggregated data as a set of three lists, as follows:

1. The Regulatory Due Diligence (RDD) Lists, covering sanctioned entities and individuals. Optionally, the Accuity Group File can be used in conjunction with this list. For more information, see [Using the Accuity Group File](#).
2. Enhanced Due Diligence (EDD) lists, covering entities and individuals who are not part of the regulatory sanctions lists, but whose activity it may be desirable to monitor.
3. The Politically Exposed Persons (PEPs) Due Diligence Database, covering PEPs.

Any or all of the lists can be downloaded and used separately or in conjunction with each other.

Please refer to the Accuity website for further details:

<http://www.accuity.com/compliance/>

## 7.8.1 Configuring the .sh File

The Accuity watch list automated download task uses the following script files that are provided with Oracle Financial Services Customer Screening to provide further configuration of the download process:

- `download-acy-edd.sh`
- `download-acy-pep.sh`
- `download-acy-san.sh`

The script files are invoked by the automated task and will download the data files and copy them to the appropriate sub-folder of the OEDQ landing area. The script files must be modified to provide the appropriate download URL and any required proxy server details for your Internet connection, as detailed in the following procedure:

1. Open the **External Tasks** node for your List Management project in the project browser, and double click on the **Download Accuity EDD** task.

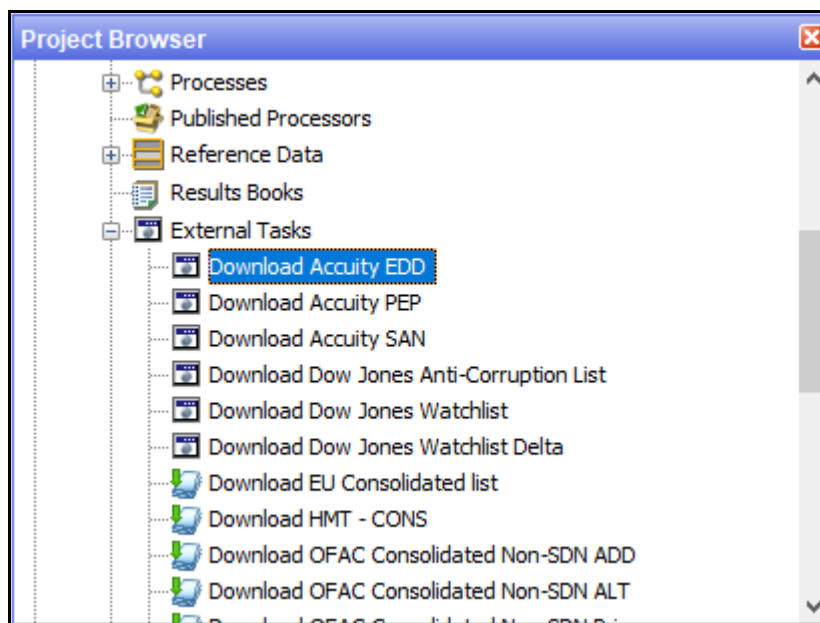

2. Replace `EDQ_DOMAIN` with the installed domain path for `EDD`, `PEP`, and `SAN`.

3. Configure your PATH system variable to include the path to your Java installation. The external file invokes Java directly, so the PATH must be configured appropriately.
4. Edit the `download-acy-edd.sh`, `download-acy-pep.sh`, and `download-acy-san.sh` script files in `<EDQ_DOMAIN>/config/fmwconfig/edq/oedq.local.home/commandarea` to include your Accuity authentication information and any proxy server configuration details that are applicable.

**NOTE**

To ensure that you have the SFTP protocol enabled for automatic password recognition, you must install `sshpass`.

### 7.8.1.1 Using the Accuity Group File

The Accuity Global Watchlist is created by aggregating many other lists. As such, any given individual or entity may be represented in the list by multiple entries.

The group file, `GROUP.XML`, provides a way to work with a data set of this type in Oracle Financial Services Customer Screening. All records which represent the same individual or entity are collected into groups, and each group is assigned a unique group ID. The group ID is used, with a prefix indicating the fact that this is a group ID, in place of the original record identifier in Case Management. Records which are not included in a group use their original Accuity record ID, with a different prefix to indicate that they are single records.

**NOTE**

The group file only applies to sanctions screening. That is, only entities and individuals on the Regulatory Due Diligence (RDD) Lists are included in the group file.

The group file allows case generation to be centered on real-world individuals, rather than separate watch list records. Groups are used by default. To change this, open the **Accuity Data Store** in the Watchlist Management project, and deselect the **Use groups** option:

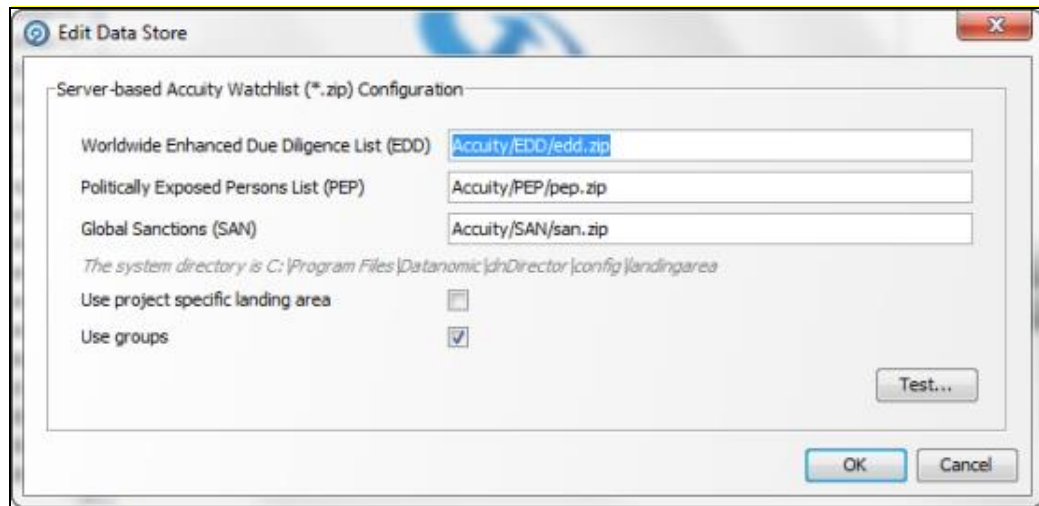

If you choose to use the group file but it is not present in your downloaded data, an error will be generated.

### 7.8.1.2 New Alerts Resulting from Use of the Group File

Using the group file causes the original list ID for an entry to be replaced with the appropriate group ID. The list ID is used in the alert key, so changes to the list ID will result in new alerts being raised for existing, known relationships. There are two main scenarios in which this may occur:

1. Individuals or entities are moved into, out of or between groups by Accuity, new alerts will be generated for existing relationships.

#### NOTE

Use of the group file may result in new alerts being raised for existing relationships if the group file structure is changed by Accuity. Currently, there is no way to circumvent this issue.

2. The Use Groups setting is changed after cases and alerts have already been generated.

#### WARNING

The setting for the Use Groups option should be selected during the implementation phase of the project. Once screening has started, it should not be changed unless absolutely necessary. Changing this setting is likely to result in existing alerts being re-raised with a new alert ID.

## OFSAAI Support

Raise a Service Request (SR) in [My Oracle Support \(MOS\)](#) for queries related to OFSAA applications.



## Send Us Your Comments

Oracle welcomes your comments and suggestions on the quality and usefulness of this publication. Your input is an important part of the information used for revision.

- Did you find any errors?
- Is the information clearly presented?
- Do you need more information? If so, where?
- Are the examples correct? Do you need more examples?
- What features did you like most about this manual?

If you find any errors or have any other suggestions for improvement, indicate the title and part number of the documentation along with the chapter/section/page number (if available) and contact the Oracle Support.

Before sending us your comments, you might like to ensure that you have the latest version of the document wherein any of your concerns have already been addressed. You can access My Oracle Support site which has all the revised/recently released documents.

