

Oracle® ZFS Storage Appliance Installation Guide

For ZS7-x, ZS5-x, ZS4-4, ZS3-x, 7x20 Controllers, and DEx-24,
Sun Disk Shelves, Release OS8.8.0

ORACLE®

Part No: E91289-02
January 2019

Part No: E91289-02

Copyright © 2009, 2019, Oracle and/or its affiliates. All rights reserved.

This software and related documentation are provided under a license agreement containing restrictions on use and disclosure and are protected by intellectual property laws. Except as expressly permitted in your license agreement or allowed by law, you may not use, copy, reproduce, translate, broadcast, modify, license, transmit, distribute, exhibit, perform, publish, or display any part, in any form, or by any means. Reverse engineering, disassembly, or decompilation of this software, unless required by law for interoperability, is prohibited.

The information contained herein is subject to change without notice and is not warranted to be error-free. If you find any errors, please report them to us in writing.

If this is software or related documentation that is delivered to the U.S. Government or anyone licensing it on behalf of the U.S. Government, then the following notice is applicable:

U.S. GOVERNMENT END USERS: Oracle programs, including any operating system, integrated software, any programs installed on the hardware, and/or documentation, delivered to U.S. Government end users are "commercial computer software" pursuant to the applicable Federal Acquisition Regulation and agency-specific supplemental regulations. As such, use, duplication, disclosure, modification, and adaptation of the programs, including any operating system, integrated software, any programs installed on the hardware, and/or documentation, shall be subject to license terms and license restrictions applicable to the programs. No other rights are granted to the U.S. Government.

This software or hardware is developed for general use in a variety of information management applications. It is not developed or intended for use in any inherently dangerous applications, including applications that may create a risk of personal injury. If you use this software or hardware in dangerous applications, then you shall be responsible to take all appropriate fail-safe, backup, redundancy, and other measures to ensure its safe use. Oracle Corporation and its affiliates disclaim any liability for any damages caused by use of this software or hardware in dangerous applications.

Oracle and Java are registered trademarks of Oracle and/or its affiliates. Other names may be trademarks of their respective owners.

Intel and Intel Xeon are trademarks or registered trademarks of Intel Corporation. All SPARC trademarks are used under license and are trademarks or registered trademarks of SPARC International, Inc. AMD, Opteron, the AMD logo, and the AMD Opteron logo are trademarks or registered trademarks of Advanced Micro Devices. UNIX is a registered trademark of The Open Group.

This software or hardware and documentation may provide access to or information about content, products, and services from third parties. Oracle Corporation and its affiliates are not responsible for and expressly disclaim all warranties of any kind with respect to third-party content, products, and services unless otherwise set forth in an applicable agreement between you and Oracle. Oracle Corporation and its affiliates will not be responsible for any loss, costs, or damages incurred due to your access to or use of third-party content, products, or services, except as set forth in an applicable agreement between you and Oracle.

Access to Oracle Support

Oracle customers that have purchased support have access to electronic support through My Oracle Support. For information, visit <http://www.oracle.com/pls/topic/lookup?ctx=acc&id=info> or visit <http://www.oracle.com/pls/topic/lookup?ctx=acc&id=trs> if you are hearing impaired.

Référence: E91289-02

Copyright © 2009, 2019, Oracle et/ou ses affiliés. Tous droits réservés.

Ce logiciel et la documentation qui l'accompagne sont protégés par les lois sur la propriété intellectuelle. Ils sont concédés sous licence et soumis à des restrictions d'utilisation et de divulgation. Sauf stipulation expresse de votre contrat de licence ou de la loi, vous ne pouvez pas copier, reproduire, traduire, diffuser, modifier, accorder de licence, transmettre, distribuer, exposer, exécuter, publier ou afficher le logiciel, même partiellement, sous quelque forme et par quelque procédé que ce soit. Par ailleurs, il est interdit de procéder à toute ingénierie inverse du logiciel, de le désassembler ou de le décompiler, excepté à des fins d'interopérabilité avec des logiciels tiers ou tel que prescrit par la loi.

Les informations fournies dans ce document sont susceptibles de modification sans préavis. Par ailleurs, Oracle Corporation ne garantit pas qu'elles soient exemptes d'erreurs et vous invite, le cas échéant, à lui en faire part par écrit.

Si ce logiciel, ou la documentation qui l'accompagne, est livré sous licence au Gouvernement des Etats-Unis, ou à quiconque qui aurait souscrit la licence de ce logiciel pour le compte du Gouvernement des Etats-Unis, la notice suivante s'applique :

U.S. GOVERNMENT END USERS: Oracle programs, including any operating system, integrated software, any programs installed on the hardware, and/or documentation, delivered to U.S. Government end users are "commercial computer software" pursuant to the applicable Federal Acquisition Regulation and agency-specific supplemental regulations. As such, use, duplication, disclosure, modification, and adaptation of the programs, including any operating system, integrated software, any programs installed on the hardware, and/or documentation, shall be subject to license terms and license restrictions applicable to the programs. No other rights are granted to the U.S. Government.

Ce logiciel ou matériel a été développé pour un usage général dans le cadre d'applications de gestion des informations. Ce logiciel ou matériel n'est pas conçu ni n'est destiné à être utilisé dans des applications à risque, notamment dans des applications pouvant causer un risque de dommages corporels. Si vous utilisez ce logiciel ou ce matériel dans le cadre d'applications dangereuses, il est de votre responsabilité de prendre toutes les mesures de secours, de sauvegarde, de redondance et autres mesures nécessaires à son utilisation dans des conditions optimales de sécurité. Oracle Corporation et ses affiliés déclinent toute responsabilité quant aux dommages causés par l'utilisation de ce logiciel ou matériel pour des applications dangereuses.

Oracle et Java sont des marques déposées d'Oracle Corporation et/ou de ses affiliés. Tout autre nom mentionné peut correspondre à des marques appartenant à d'autres propriétaires qu'Oracle.

Intel et Intel Xeon sont des marques ou des marques déposées d'Intel Corporation. Toutes les marques SPARC sont utilisées sous licence et sont des marques ou des marques déposées de SPARC International, Inc. AMD, Opteron, le logo AMD et le logo AMD Opteron sont des marques ou des marques déposées d'Advanced Micro Devices. UNIX est une marque déposée de The Open Group.

Ce logiciel ou matériel et la documentation qui l'accompagne peuvent fournir des informations ou des liens donnant accès à des contenus, des produits et des services émanant de tiers. Oracle Corporation et ses affiliés déclinent toute responsabilité ou garantie expresse quant aux contenus, produits ou services émanant de tiers, sauf mention contraire stipulée dans un contrat entre vous et Oracle. En aucun cas, Oracle Corporation et ses affiliés ne sauraient être tenus pour responsables des pertes subies, des coûts occasionnés ou des dommages causés par l'accès à des contenus, produits ou services tiers, ou à leur utilisation, sauf mention contraire stipulée dans un contrat entre vous et Oracle.

Accès aux services de support Oracle

Les clients Oracle qui ont souscrit un contrat de support ont accès au support électronique via My Oracle Support. Pour plus d'informations, visitez le site <http://www.oracle.com/pls/topic/lookup?ctx=acc&id=info> ou le site <http://www.oracle.com/pls/topic/lookup?ctx=acc&id=trs> si vous êtes malentendant.

Contents

Installation Overview	11
Installation Prerequisites and Hardware Overviews	13
Prerequisites for Installation	13
Security Information	14
Safety Information	14
Cabinet and Tool Requirements	14
▼ Disconnecting an RJ-45 Cable	16
Cabinet Configuration Guidelines	17
Cabinet Configuration	17
Load Distribution	17
Cable Lengths	18
Cable Bend Radius	18
Supported Disk Shelf Combinations and HBAs	19
Maximum Disk Shelves per Controller Configuration	20
Overview of Disk Shelves	23
Oracle Storage Drive Enclosure DE3-24	23
Oracle Storage Drive Enclosure DE2-24	31
Sun Disk Shelf	37
Disk Shelf Components	41
Overview of ZS7-2 Controller	42
ZS7-2 Physical Specifications	42
ZS7-2 Electrical Specifications	43
ZS7-2 Acoustic Noise Emissions	43
ZS7-2 Configuration Options	43
ZS7-2 Front Panel Components	44
ZS7-2 Rear Panel Components	46
Overview of ZS5-4 Controller	47

ZS5-4 Physical Specifications	47
ZS5-4 Electrical Specifications	47
ZS5-4 Acoustic Noise Emissions	48
ZS5-4 Configuration Options	48
ZS5-4 Front Panel Components	48
ZS5-4 Rear Panel Components	49
Overview of ZS5-2 Controller	51
ZS5-2 Physical Specifications	51
ZS5-2 Electrical Specifications	51
ZS5-2 Acoustic Noise Emissions	52
ZS5-2 Configuration Options	52
ZS5-2 Front Panel Components	52
ZS5-2 Rear Panel Components	53
Cable Management Arm	54
Overview of ZS4-4 Controller	56
ZS4-4 Front Panel Components	56
ZS4-4 Rear Panel Components	57
Overview of ZS3-4 Controller	60
ZS3-4 Electrical Specifications	60
ZS3-4 Configuration Options	60
ZS3-4 Front Panel Components	61
ZS3-4 Rear Panel Components	62
Overview of ZS3-2 Controller	64
ZS3-2 Physical Specifications	64
ZS3-2 Electrical Specifications	64
ZS3-2 Acoustic Noise Emissions	65
ZS3-2 Configuration Options	65
ZS3-2 Front Panel Components	65
ZS3-2 Rear Panel Components	66
Optional Cable Management Arm	69
Overview of 7420 Controller	70
7420 Physical Specifications	70
7420 Electrical Specifications	70
7420 Configuration Options	71
7420 Front Panel Components	72
7420 Rear Panel Components	73
Overview of 7320 Controller	74

7320 Electrical Specifications	75
7320 Base Configurations	75
7320 Front Panel Components	76
7320 Rear Panel Components	77
Overview of 7120 Controller	78
7120 Physical Specifications	78
7120 Electrical Specifications	78
7120 Front Panel Components	79
7120 Rear Panel Components	80
Installing Disk Shelves	83
▼ Installing a DE3-24P Disk Shelf	83
▼ Installing a DE3-24C Disk Shelf	87
▼ Installing a DE2-24P Disk Shelf	93
▼ Installing a DE2-24C Disk Shelf	98
▼ Installing a Sun Disk Shelf	103
Installing a ZS7-2 Controller	109
▼ Installing the Slide Rails onto a ZS7-2	109
▼ Installing the Slide Rails into the Rack for a ZS7-2	110
▼ Installing a ZS7-2 onto the Rack Slide Rails	112
▼ Installing a ZS7-2 Cable Management Arm	114
▼ Verifying Operation of ZS7-2 Slide-Rails and CMA	121
Installing a ZS5-4 Controller	123
▼ Installing the Slide Rails onto a ZS5-4	123
▼ Installing the Slide Rails into the Rack for a ZS5-4	124
▼ Installing a ZS5-4 onto the Rack Slide Rails	126
▼ Installing a ZS5-4 Cable Management Arm	128
▼ Verifying Operation of ZS5-4 Slide-Rails and CMA	130
Installing a ZS5-2 Controller	133
▼ Installing the Mounting Brackets and Slide Rail Assemblies for a ZS5-2	133
▼ Installing a ZS5-2 onto the Rack Slide Rails	139
▼ Installing a ZS5-2 Cable Management Arm	140
▼ Verifying Operation of ZS5-2 Slide-Rails and CMA	150

Installing a ZS4-4 or ZS3-4 Controller	151
▼ Installing the Slide Rails onto a ZS4-4 or ZS3-4	151
▼ Installing the Slide Rails into the Rack for a ZS4-4 or ZS3-4	152
▼ Installing a ZS4-4 or ZS3-4 onto the Rack Slide Rails	154
▼ Installing a ZS4-4 or ZS3-4 Cable Management Arm	157
Installing a ZS3-2 Controller	161
▼ Installing the Mounting Brackets and Slide Rail Assemblies for a ZS3-2	161
▼ Installing a ZS3-2 onto the Rack Slide Rails	167
▼ Installing a ZS3-2 Cable Management Arm	168
▼ Verifying Operation of ZS3-2 Slide-Rails and CMA	177
Installing a 7x20 Controller	179
▼ Removing the 7x20 Mounting Brackets from inside the Slide Rails	179
▼ Installing the Mounting Brackets on a 7x20	181
▼ Installing a 7x20 onto the Rack Slide Rails	183
▼ Installing a 7x20 Cable Management Arm	188
Cabling the Appliance	195
▼ Connecting System Cables	195
▼ Connecting Cluster Cables	196
▼ Connecting Disk Shelf Cables	200
Powering On the Appliance	203
▼ Powering On a DE3-24 or DE2-24 Disk Shelf	203
▼ Powering On a Sun Disk Shelf	205
▼ Powering On a Controller	205
Powering Off a Controller	206
▼ Powering Off a Disk Shelf	207
Configuring the Appliance for the First Time	209
▼ Configuring the System	210
▼ Performing Initial Configuration (BUI)	213
▼ Performing Initial Configuration (CLI)	227

Troubleshooting Hardware Faults	237
▼ Connecting to Oracle ILOM	237

Installation Overview

This guide describes installation procedures for Oracle ZFS Storage Appliance.

Each controller should have at least one NIC port configured as a management interface. If necessary, install additional NIC card(s) into the appropriate PCIe slot(s) before initial controller installation. For information on installing a PCIe card, see the appropriate section for your controller in the [Oracle ZFS Storage Appliance Customer Service Manual](#).

Follow these steps to install your appliance:

1. Read [“Prerequisites for Installation”](#) on page 13.
2. Review the information about your disk shelves and controllers in [“Installation Prerequisites and Hardware Overviews”](#) on page 13.
3. Install your disk shelves using the appropriate procedure in [“Installing Disk Shelves”](#) on page 83.
4. Install your controllers:
 - [“Installing a ZS7-2 Controller”](#) on page 109
 - [“Installing a ZS5-4 Controller”](#) on page 123
 - [“Installing a ZS5-2 Controller”](#) on page 133
 - [“Installing a ZS4-4 or ZS3-4 Controller”](#) on page 151
 - [“Installing a ZS3-2 Controller”](#) on page 161
 - [“Installing a 7x20 Controller”](#) on page 179
5. Cable the appliance as described in [Getting Started with Cabling](#).
For the maximum number of disk shelves supported per controller configuration, see [“Maximum Disk Shelves per Controller Configuration”](#) on page 20.
6. Power on your appliance using the procedures in [“Powering On the Appliance”](#) on page 203.
7. Complete first-time configuration and prepare the appliance for production using the procedures in [“Configuring the Appliance for the First Time”](#) on page 209.

For information about troubleshooting hardware faults using Oracle Integrated Lights Out Manager (ILOM), see [“Troubleshooting Hardware Faults”](#) on page 237.

Installation Prerequisites and Hardware Overviews

This section gives an overview of the Oracle ZFS Storage Appliance disk shelves and controllers, as well as the prerequisites for installation.

For safety information and configuration guidelines, see:

- [“Prerequisites for Installation” on page 13](#)
- [“Cabinet Configuration Guidelines” on page 17](#)
- [“Maximum Disk Shelves per Controller Configuration” on page 20](#)

For hardware overviews, see:

- [“Overview of Disk Shelves” on page 23](#)
- [“Overview of ZS7-2 Controller” on page 42](#)
- [“Overview of ZS5-4 Controller” on page 47](#)
- [“Overview of ZS5-2 Controller” on page 51](#)
- [“Overview of ZS4-4 Controller” on page 56](#)
- [“Overview of ZS3-4 Controller” on page 60](#)
- [“Overview of ZS3-2 Controller” on page 64](#)
- [“Overview of 7420 Controller” on page 70](#)
- [“Overview of 7320 Controller” on page 74](#)
- [“Overview of 7120 Controller” on page 78](#)

Prerequisites for Installation

This section contains the safety information as well as the tools and information required for installing Oracle ZFS Storage Appliance disk shelves and controllers.

Read the following sections before beginning installation:

- [“Security Information” on page 14](#)

- [“Safety Information” on page 14](#)
- [“Cabinet and Tool Requirements” on page 14](#)
- [“Disconnecting an RJ-45 Cable” on page 16](#)

Security Information

To understand the security issues relevant to initial installation of the Oracle ZFS Storage Appliance, refer to the [Oracle ZFS Storage Appliance Security Guide, Release OS8.8.0](#).

Safety Information

Take the following precautions when installing disk shelves and controllers into a rack.

Note - If your rail kit shipped with installation instructions, use those instructions instead.

- Before you begin installation, read the Safety Agency Compliance Statements section in the Safety and Compliance Guide for your controller.
- For safety reasons, mount the heaviest equipment, typically disk shelves, at the bottom of the rack. For rack-mounting guidelines, refer to the Safety and Compliance Guide for your controller.
- Always load equipment into a rack from the bottom up so that it will not become top-heavy and tip over. Deploy the anti-tip bar to prevent the rack from tipping during equipment installation.
- Ensure that the temperature in the rack will not exceed the equipment's maximum ambient rated temperatures. Consider the total airflow requirements of all equipment installed in the rack to ensure that the equipment is operated within its specified temperature range.
- Always use the width spacer alignment tool when installing rails into racks that use cage nuts and mounting screws. Failure to use the spacer can cause the glides and sliders to jam and damage the rail.
- Do not remove a component if you do not have an immediate replacement. The disk shelf must not be operated without all components in place.
- Do not lift a disk shelf by the handles on the power supply with fan modules; they are not designed to take the weight.

Cabinet and Tool Requirements

Use one of the following racks for a DEx-24 disk shelf:

Note - Position the rack where the shelf is to be installed adjacent to the rack where the controller is installed, if separate. Stabilize the cabinet and lock the casters. To facilitate access, remove doors from cabinets.

- Oracle Rack Cabinet 1242
- Sun Rack II 1042/1242 cabinet
- Any 19-inch wide, 4-post, EIA-compatible rack or cabinet with a front-to-back depth between vertical cabinet rails of 61 cm to 91 cm (24 in. to 36 in.). The cabinet can have threaded or unthreaded cabinet rails. Threaded cabinets must be M6 or 10-32 cabinets. Cabinets must be able to support the weight of all equipment contained within them.

Use one of the following racks for a Sun Disk Shelf:

Note - Position the rack where the shelf is to be installed adjacent to the rack where the controller is installed, if separate. Stabilize the cabinet and lock the casters.

- Sun Rack 900/1000 cabinet
- Sun Fire cabinet
- Sun StorEdge Expansion cabinet
- Sun Rack II 1042/1242 cabinet
- Any 19-inch wide, 4-post, EIA-compatible rack or cabinet with a front-to-back depth between vertical cabinet rails of 61 cm to 91 cm (24 in. to 36 in.). The cabinet can have threaded or unthreaded cabinet rails.

To install a disk shelf, you need the following tools:

- A Phillips-head No. 2 screwdriver that is a minimum of 4 inches long.
- A T20 Torx driver, if using a threaded cabinet (DE2-24P).
- A mechanical lift is highly recommended because the chassis can be too heavy to lift otherwise. At least three people are required: two to install the shelf and one spotter to engage the rails.

Note - For DEx-24 disk shelves, if a mechanical lift is not available, you can remove the power supply with fan modules to reduce the weight. For instructions, refer to [“Servicing the Disk Shelves”](#) in *Oracle ZFS Storage Appliance Customer Service Manual*.

- A flashlight for the spotter to ensure the shelf is engaged in the rails.

To install a controller, you need the following tools:

- No. 2 Phillips screwdriver

- ESD mat and grounding strap
- Pencil, stylus, or other pointed device, for pushing front panel buttons
- Optional mechanical lift

You also need a system console device, such as one of the following:

- Workstation
- ASCII terminal
- Terminal server
- Patch panel connected to a terminal server

▼ Disconnecting an RJ-45 Cable

Use the following procedure to properly disconnect an RJ-45 cable.

1. **Using your index finger, press down fully on the RJ-45 release tab. Be sure the tab is fully disengaged from the port.**

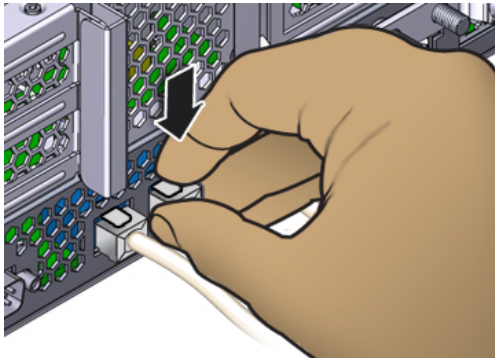

2. **Using your thumb and middle finger, apply a slight downward pressure while pulling the plug out of the port. *Do not* pull the plug upward or pinch the release tab with your fingers below the plug, as shown below.**

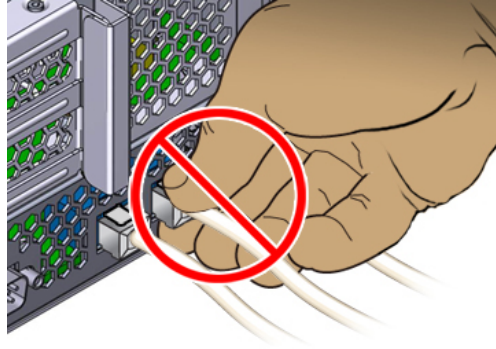

Cabinet Configuration Guidelines

This section contains guidelines for properly placing and connecting the disk shelves.

Cabinet Configuration

- For safety reasons, mount the heaviest equipment, typically disk shelves, at the bottom of the cabinet. Refer to the appropriate Oracle Safety and Compliance Guide for rack-mounting guidelines.
- To best prepare for cabling controllers to disk shelves, now and in the future, mount controllers in the middle of the cabinet. This also allows for optimal air circulation, whether in a floor- or ceiling-cooled environment.
- Do not remove cabinet panels to run cables between cabinets.

Load Distribution

- Balance the number of disk shelves across the disk chains in your system.
- Balance the number of disk chains across the number of HBAs in your system. For example, attaching two chains to two separate HBAs will have better performance than attaching two chains to a single HBA.
- Do not mix disks with different capacities or rotation speeds within a single disk shelf.
- To maximize performance, use the maximum number of disk chains supported by the controller's SAS HBAs. For example, four SAS HBAs with eight chains and eight disk

shelves will have better performance than two SAS HBAs with four chains and eight disk shelves.

- To maximize performance, do not attach more than four DE2-24C, DE2-24P, or DE3-24C disk shelves to a single chain, and do not attach more than three DE3-24P disk shelves to a single chain. This only applies to systems that are performance critical. The maximum of six disk shelves per chain is available for cases where capacity is preferred over performance.

Cable Lengths

- Active optical cables (AOCs) are required for attaching ZS7-2 controllers to DE3-24 disk shelves. Other controllers and/or disk shelves in the future may adapt AOC cabling. AOCs are available in the following lengths: 3 meters, 6 meters, and 20 meters. The maximum AOC length between a controller and disk shelves that span further than two adjacent cabinets is 20 meters.
- The maximum copper cable length between a controller and disk shelves is 6 meters.
- The maximum copper or AOC cable length between DE3-24 disk shelves in a single chain that spans two adjacent cabinets is 6 meters copper, 6 meters AOC, or 20 meters AOC; only one pair of 6-meter cables is allowed per chain.
- The maximum copper cable length between DE3-24 disk shelves that span across adjacent cabinets is 3 meters.
- The maximum copper cable length between DE2-24 disk shelves that span across adjacent cabinets is 3 meters.
- The maximum copper cable length between Sun Disk Shelves that span across adjacent cabinets is 3 meters.

Cable Bend Radius

Do not bend SAS cables less than the following minimum radius:

SAS Cable Type	SAS Cable Length	Minimum Bend Radius
Copper	1 meter	26 mm
Copper	3 meters	28 mm
Copper	6 meters	35 mm
Active Optic Cable	All lengths	25 mm

Supported Disk Shelf Combinations and HBAs

Disk shelves are supported by specific HBAs in the controller, and can be combined in certain configurations within a system. Use the following table to determine the HBA type required by each disk shelf model.

TABLE 1 Required HBA per Disk Shelf Model

Disk Shelf Model	Required HBA
DE3-24P All-Flash	SAS-3 4x4 port HBA
DE3-24 Disk Shelf	SAS-3 4x4 port HBA or SAS-2 4x4 port HBA
DE2-24 Disk Shelf	SAS-3 4x4 port HBA, SAS-2 4x4 port HBA or SAS-2 2x4 port HBA
Sun Disk Shelf	SAS-2 4x4 port HBA or SAS-2 2x4 port HBA
DE2-24 and Sun Disk Shelf together	SAS-2 4x4 port HBA SAS-2 2x4 port HBA for only Sun ZFS Storage 7120

The following table describes which disk shelf models can be used together for which controller configurations, starting with software release OS8.7.0. See [“Cabinet and Cabling Guidelines” in Oracle ZFS Storage Appliance Cabling Guide](#) for disk shelf intermixing guidelines and all-flash disk shelf usage. To understand which controllers support which HBA types, see [“Maximum Disk Shelves per Controller Configuration” on page 20](#).

Note - For optimal performance, do not attach all-flash and non-all-flash disk shelves to the same SAS-3 HBA.

TABLE 2 Supported Disk Shelf Combinations per Controller Configuration

Controller Configuration	DE3-24P All-Flash	All DE3 Disk Shelves (except All-Flash)	All DE2 Disk Shelves	DE3 and DE2 Disk Shelves	DE2 and Sun Disk Shelves
ZS7-2 with SAS-3 4x4 port HBAs	Yes	Yes	No	No	No
ZS5-4 with SAS-3 4x4 port HBAs	Yes	Yes	Yes	Yes	No
ZS5-4 with SAS-2 4x4 port HBAs	No	Yes	Yes	Yes	No
ZS5-2 with SAS-3 4x4 port HBAs	Yes	Yes	Yes	Yes	No

Maximum Disk Shelves per Controller Configuration

Controller Configuration	DE3-24P All-Flash	All DE3 Disk Shelves (except All-Flash)	All DE2 Disk Shelves	DE3 and DE2 Disk Shelves	DE2 and Sun Disk Shelves
ZS5-2 with SAS-2 4x4 port HBAs	No	Yes	Yes	Yes	No
ZS4-4 with SAS-3 4x4 port HBAs	Yes	Yes	Yes	Yes	No
ZS4-4 with SAS-2 4x4 port HBAs	No	Yes	Yes	Yes	No
ZS3-4 with SAS-2 4x4 port HBAs	No	Yes	Yes	Yes	Yes
ZS3-2 with SAS-3 4x4 port HBAs	No	Yes	Yes	Yes	No
ZS3-2 with SAS-2 4x4 port HBAs	No	Yes	Yes	Yes	Yes
7420 with SAS-2 4x4 port HBAs	No	No	Yes	No	Yes
7420 with SAS-2 2x4 port HBAs	No	No	Yes	No	No
7320 with SAS-2 4x4 port HBAs	No	No	Yes	No	Yes
7320 with SAS-2 2x4 port HBAs	No	No	Yes	No	No
7120 with SAS-2 2x4 port HBAs	No	No	Yes	No	Yes

Maximum Disk Shelves per Controller Configuration

When determining how many disk shelves a controller configuration supports, it is important to remember that each disk shelf chain can support up to six disk shelves, and some controller configurations are limited to a specific number of total disk shelves. The following table details the number of supported disk shelf chains per HBA type.

TABLE 3 Supported Disk Shelf Chains per HBA

HBA Type	Number of Disk Shelf Chains per HBA
SAS-3 4x4 port	2

HBA Type	Number of Disk Shelf Chains per HBA
SAS-2 4x4 port	2
SAS-2 2x4 port	1

As of software release OS8.7.0, 4x4 port SAS-3 HBAs and 4x4 port SAS-2 HBAs can be used together in the same system. Controllers cannot simultaneously use 2x4 port SAS-2 HBAs and 4x4 port SAS-2 HBAs. Sun Disk Shelves are not supported in any system that includes a SAS-3 HBA, or a combination of SAS-3 and SAS-2 HBAs.

The following table shows the maximum number of HBAs per controller, and the maximum number of disk shelves supported per controller configuration. Both standalone and clustered controllers support the same maximum number of disk shelves. For information on disk compatibility, see the [Oracle Systems Handbook](#).

TABLE 4 Maximum Disk Shelves per Controller Configuration

Controller	Max. Shelves	Max. 2x4 Port SAS-2 HBA	Max. 4x4 Port SAS-2 HBA	Max. 4x4 Port SAS-3 HBA	Guidelines
ZS7-2 high-end model	48	NA	NA	4	Disk shelves can include 24x HDD/SSD, or combine 20x HDD/SSD plus 4x write-optimized and/or read-optimized flash accelerators (SSDs). Total number of chains is eight. Any combination of disk-only and write- or read-optimized shelves may be combined within the chain in any order.
ZS7-2 mid-range model	16	NA	NA	2	Disk shelves can include 24x HDD/SSD, or combine 20x HDD/SSD plus 4x write-optimized and/or read-optimized flash accelerators (SSDs). Total number of chains is four. Any combination of disk-only and write- or read-optimized shelves may be combined within the chain in any order.
ZS5-4	48	NA	4	4	Disk shelves can include 24x HDD/SSD, or combine 20x HDD/SSD plus 4x write-optimized and/or read-optimized flash accelerators (SSDs). Total number of chains is eight. Any combination of disk-only and write- or read-optimized shelves may be combined within the chain in any order.
ZS5-2	16	NA	2	2	Disk shelves can include 24x HDD/SSD, or combine 20x HDD/SSD plus 4x write-optimized and/or read-optimized flash accelerators (SSDs). Total number of chains is four. Any combination of disk-only and write- or read-optimized shelves may be combined within the chain in any order.
ZS4-4	36	NA	4	4	Disk shelves can include 24x HDD/SSD, or combine 20x HDD/SSD plus 4x write-optimized and/or read-optimized flash accelerators (SSDs). Total number of chains is eight. Any combination of disk-only and write-

Maximum Disk Shelves per Controller Configuration

Controller	Max. Shelves	Max. 2x4 Port SAS-2 HBA	Max. 4x4 Port SAS-2 HBA	Max. 4x4 Port SAS-3 HBA	Guidelines
					optimized shelves can be combined within the chain in any order.
ZS3-4	36	NA	4	NA	Disk shelves can include 24x HDD, or combine 20x HDD plus 4x write-optimized flash accelerators (SSDs). Total number of chains is eight. Any combination of disk-only and write-optimized shelves can be combined within the chain in any order. You can also connect mixed disk shelf types (DE2 and legacy Sun Disk Shelves) to the same controllers, but each chain must contain only the same disk shelf type. Directly connecting different disk shelf types is not supported.
ZS3-2	16	NA	2	2	Disk shelves can include 24x HDD, or combine 20x HDD plus 4x write-optimized flash accelerators (SSDs). Total number of chains is four. Any combination of disk-only and write-optimized shelves can be combined within the chain in any order. You can also connect mixed disk shelf types (DE2 and legacy Sun Disk Shelves) to the same controllers, but each chain must contain only the same disk shelf type. Directly connecting different disk shelf types is not supported.
7420	36	6	6	NA	Disk shelves can include 24x HDD, or combine 20x HDD plus 4x write-optimized flash accelerators (SSDs). Total number of chains is six with 2X4 port SAS-2 HBAs, and 12 with 4X4 port SAS-2 HBAs. Any combination of disk-only and write-optimized shelves can be combined within the chain in any order. You can also connect mixed disk shelf types (DE2 and legacy Sun Disk Shelves) to the same controllers, but each chain must contain only the same disk shelf type. Directly connecting different disk shelf types is not supported.
7320	6	1	1	NA	Any combination of disk-only and write-optimized shelves may be combined within the chain in any order. The cabling configurations are unchanged. You can also connect mixed disk shelf types (DE2 and legacy Sun Disk Shelves) to the same controllers, but each chain must contain only the same disk shelf type. Directly connecting different disk shelf types is not supported.
7120	2	1	NA	NA	Write-optimized SSDs are not supported in the expansion storage for the 7120. The disk shelves must be fully populated with 24 HDDs. You can also connect mixed disk shelf types (DE2 and legacy Sun Disk Shelves) to the same controllers.

Overview of Disk Shelves

This section provides an overview of the Oracle ZFS Storage Appliance disk shelves. For installation instructions, refer to [“Installing Disk Shelves” on page 83](#). For service instructions, refer to [“Servicing the Disk Shelves” in Oracle ZFS Storage Appliance Customer Service Manual](#). For information on disk compatibility, refer to [Oracle Systems Handbook](#).

Oracle disk shelves are high-availability serial attached SCSI (SAS) devices that provide expanded storage. The main components are hot-swappable, including drives, I/O Modules (IOMs) or SAS Interface Module (SIM) boards for connecting to controllers and other disk shelves, and dual load-sharing power supply with fan modules. This provides a fault-tolerant environment with no single point of failure. Component status is indicated with lights on the disk shelf, and in the Maintenance Hardware screen of the BUI.

To understand disk shelf components and configurations, see the following topics.

- [“Oracle Storage Drive Enclosure DE3-24” on page 23](#)
- [“Oracle Storage Drive Enclosure DE2-24” on page 31](#)
- [“Sun Disk Shelf” on page 37](#)
- [“Disk Shelf Components” on page 41](#)

Oracle Storage Drive Enclosure DE3-24

This section introduces the front and rear panel components of the DE3-24P and DE3-24C disk shelves.

DE3-24P Disk Shelf

The Oracle Storage Drive Enclosure DE3-24P is a 2U chassis that supports 24 2.5" SAS-3 drives. The high-performance HDDs provide reliable storage. The SSDs provide accelerated write operations, and for some controllers, read-optimized cache operations. This disk shelf features dual, redundant I/O Modules (IOMs), and dual power supply with fan modules.

FIGURE 1 DE3-24P Drive Locations (Front View)

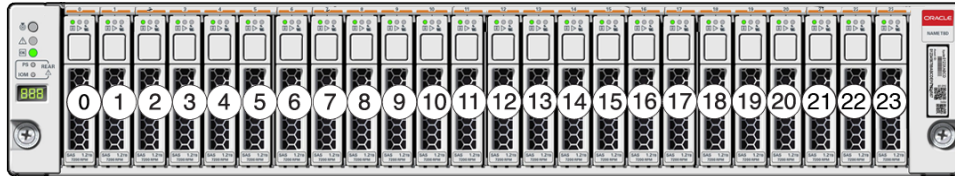

Up to four write-optimized log SSDs are supported per disk shelf. Log devices should be populated in order of slots 20, 21, 22, and 23.

Read-optimized cache SSDs can also be installed in the DE3-24P disk shelf, for some controllers. For slot configuration details and minimum software requirements, see [“Disk Shelf Configurations” in Oracle ZFS Storage Appliance Customer Service Manual](#).

FIGURE 2 DE3-24P Status Indicators (Front View)

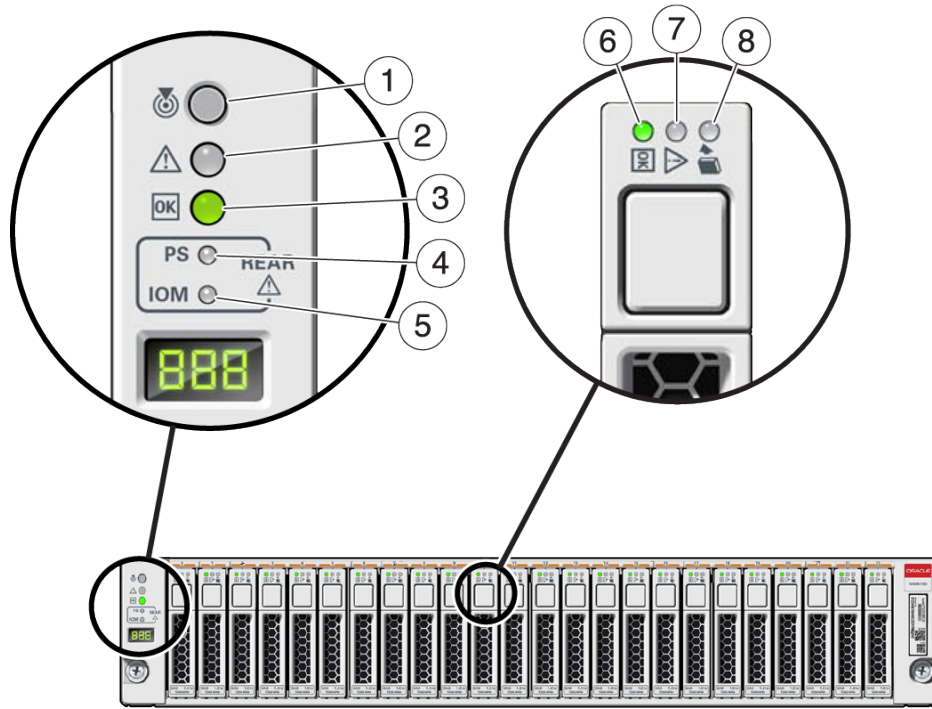

Figure Legend		
1 Locate indicator	2 Service required indicator	3 OK indicator
4 Power supply fault indicator	5 SAS I/O Module fault indicator	6 Power/Activity indicator
7 Drive service required indicator	8 Ready-to-remove indicator	

FIGURE 3 DE3-24P Rear Panel

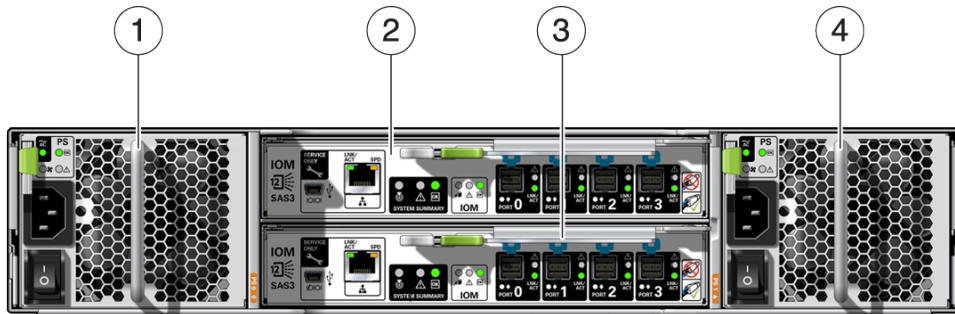

Figure Legend

1 Power supply with fan module 0	2 I/O Module 1
3 I/O Module 0	4 Power supply with fan module 1

DE3-24C Disk Shelf

The Oracle Storage Drive Enclosure DE3-24C is a 4U chassis that supports 24 3.5" SAS-3 drives. The high-performance HDDs provide reliable storage. The SSDs provide accelerated write operations, and for some controllers, read-optimized cache operations. This disk shelf features dual, redundant I/O Modules (IOMs), and dual power supply with fan modules.

FIGURE 4 DE3-24C Drive Locations (Front View)

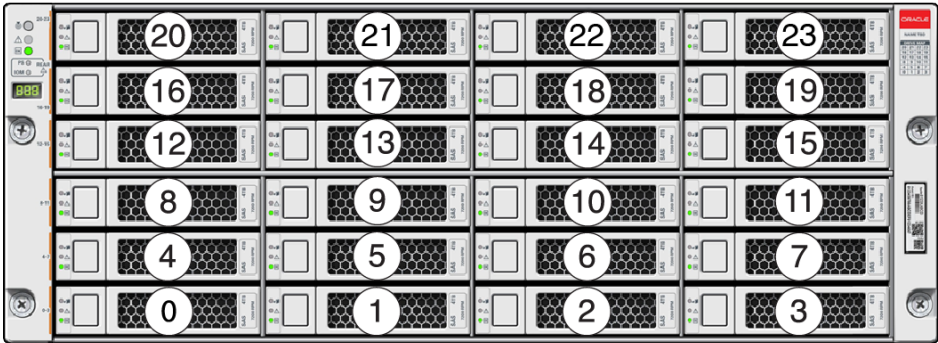

Up to four write-optimized log SSDs are supported per disk shelf. Log devices should be populated in order of slots 20, 21, 22, and 23.

Read-optimized cache SSDs can also be installed in the DE3-24C disk shelf, for some controllers. For slot configuration details and minimum software requirements, see [“Disk Shelf Configurations” in Oracle ZFS Storage Appliance Customer Service Manual](#).

FIGURE 5 DE3-24C Status Indicators (Front View)

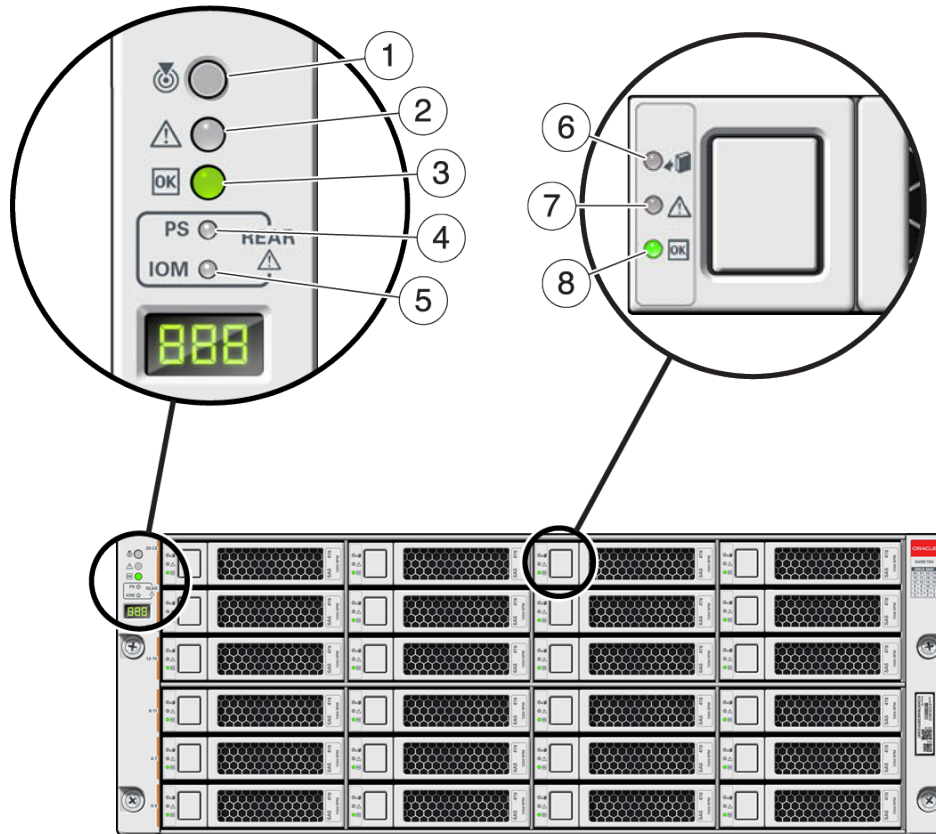

Figure Legend

1 Locate indicator	2 Service required indicator	3 OK indicator
4 Power supply fault indicator	5 SAS I/O Module fault indicator	6 Ready-to-remove indicator
7 Drive service required indicator	8 Power/Activity indicator	

FIGURE 6 DE3-24C Rear Panel

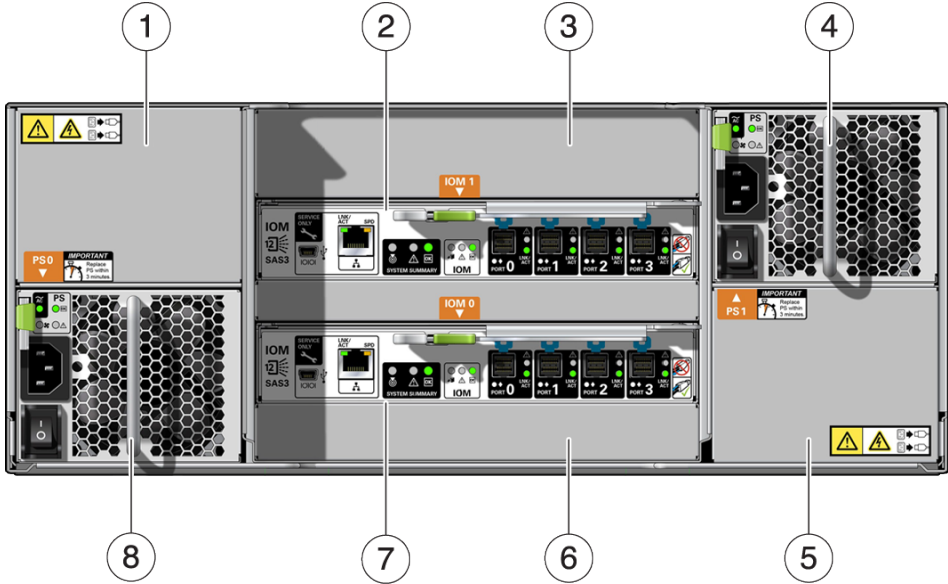

Figure Legend		
1 Power supply filler panel, slot 4	2 I/O Module 1	3 I/O Module filler panel
4 Power supply with fan module 2	5 Power supply filler panel, slot 2	6 I/O Module filler panel
7 I/O Module 0	8 Power supply with fan module 1	

Note - It is especially important that power supplies and their filler panels are in the correct slots.

FIGURE 7 DE3 I/O Module Indicators

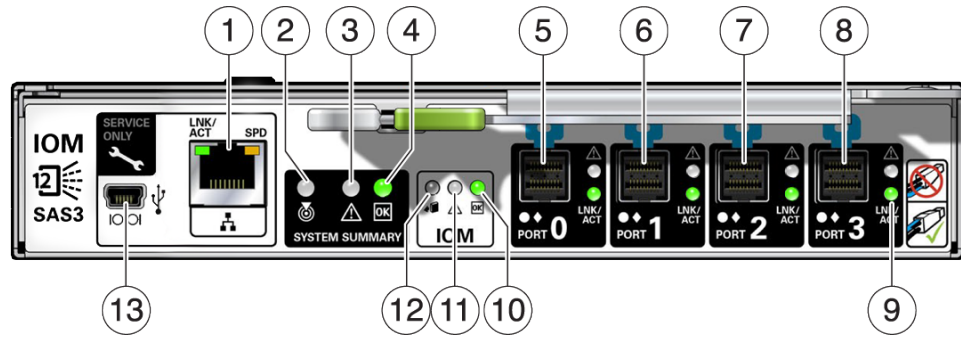

Figure Legend

1 For Oracle service only	2 Locate indicator	3 Service required indicator
4 OK indicator	5 SAS-3 Port 0	6 SAS-3 Port 1
7 SAS-3 Port 2	8 SAS-3 Port 3	9 Host port activity indicator
10 Power/Activity indicator	11 Drive service required indicator	12 Ready-to-remove indicator
13 For Oracle service only		

The DE3-24C and DE3-24P disk shelves use the same I/O Module.

FIGURE 8 DE3 Power Supply Indicators

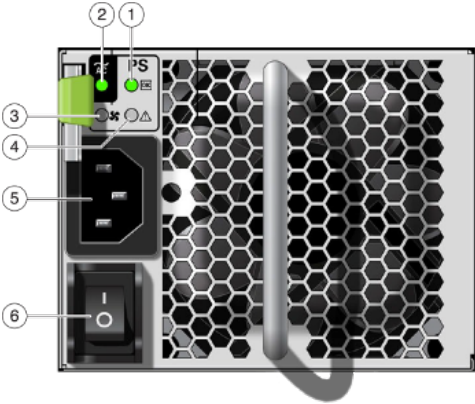

Figure Legend		
1 Power supply status indicator	2 AC power fail indicator	3 Fan fail indicator
4 DC power fail indicator	5 Universal power input connector	6 Power on/off switch

The DE3-24C and DE3-24P disk shelves use the same power supply.

Oracle Storage Drive Enclosure DE2-24

This section introduces the front and rear panel components of the DE2-24P and DE2-24C disk shelves.

DE2-24 Disk Shelf

The Oracle Storage Drive Enclosure DE2-24P is a 2U chassis that supports 24 2.5" SAS-2 drives. The high-capacity HDDs provide reliable storage. The SSDs provide accelerated write operations, and for some controllers, read-optimized cache operations. This disk shelf features dual, redundant I/O Modules (IOMs), and dual power supply with fan modules.

FIGURE 9 DE2-24P Drive Locations (Front View)



Up to four write-optimized log SSDs are supported per disk shelf. Log devices should be populated in order of slots 20, 21, 22, and 23.

Read-optimized cache SSDs can also be installed in the DE2-24P disk shelf, for some controllers. For slot configuration details and minimum software requirements, see [“Disk Shelf Configurations” in Oracle ZFS Storage Appliance Customer Service Manual](#).

FIGURE 10 DE2-24P Status Indicators (Front View)

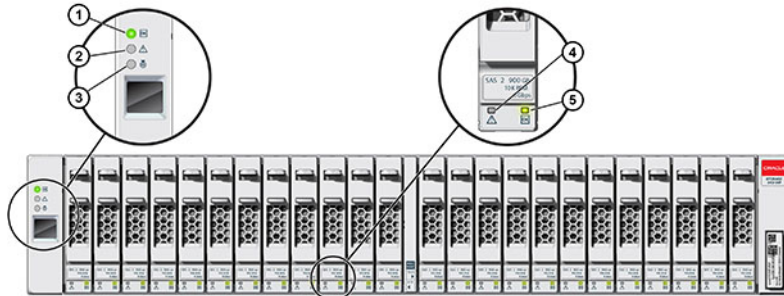
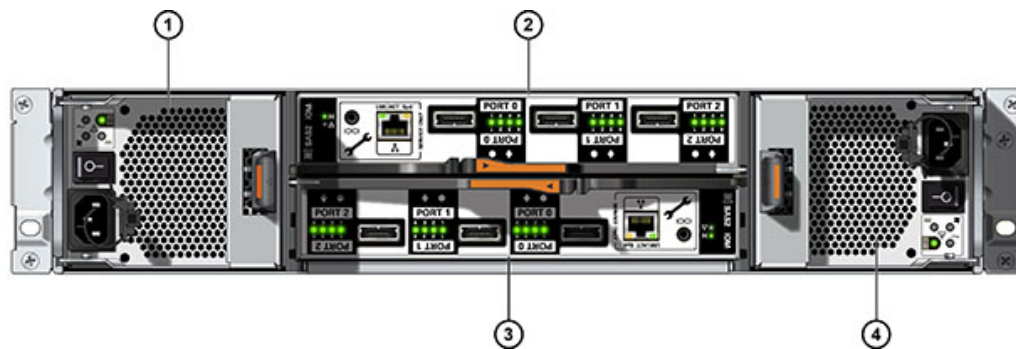

Figure Legend

1 System power indicator	2 Module fault indicator	3 Locate indicator
4 Power/Activity indicator	5 Drive fault indicator	

FIGURE 11 DE2-24P Rear Panel**Figure Legend**

1 Power supply with fan module 0

2 I/O Module 1

3 I/O Module 0

4 Power supply with fan module 1

DE2-24C Disk Shelf

The Oracle Storage Drive Enclosure DE2-24C is a 4U chassis that supports 24 3.5" SAS-2 drives. The high-capacity HDDs provide reliable storage. The SSDs provide accelerated write operations, and for some controllers, read-optimized cache operations. This disk shelf features dual, redundant I/O Modules (IOMs), and dual power supply with fan modules.

FIGURE 12 DE2-24C Drive Locations (Front View)



Up to four write-optimized log SSDs are supported per disk shelf. Log devices should be populated in order of slots 20, 21, 22, and 23.

Read-optimized cache SSDs can also be installed in the DE2-24C disk shelf, for some controllers. For slot configuration details and minimum software requirements, see [“Disk Shelf Configurations” in Oracle ZFS Storage Appliance Customer Service Manual](#).

FIGURE 13 DE2-24C Status Indicators (Front View)

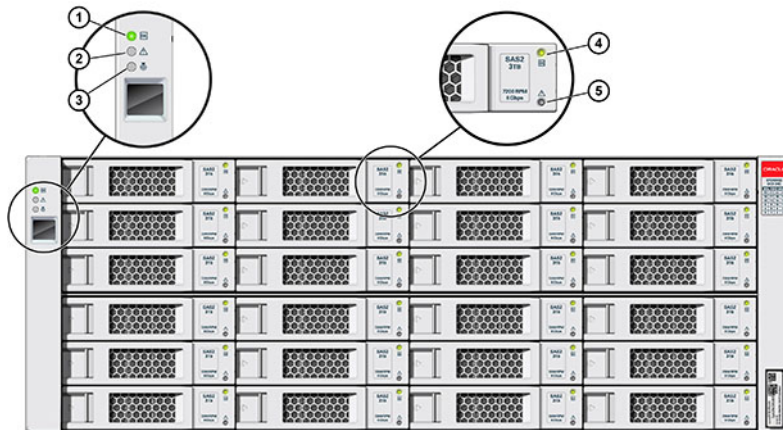

Figure Legend

1 System power indicator	2 Module fault indicator	3 Locate indicator
4 Power/Activity indicator	5 Drive fault indicator	

FIGURE 14 DE2-24C Rear Panel

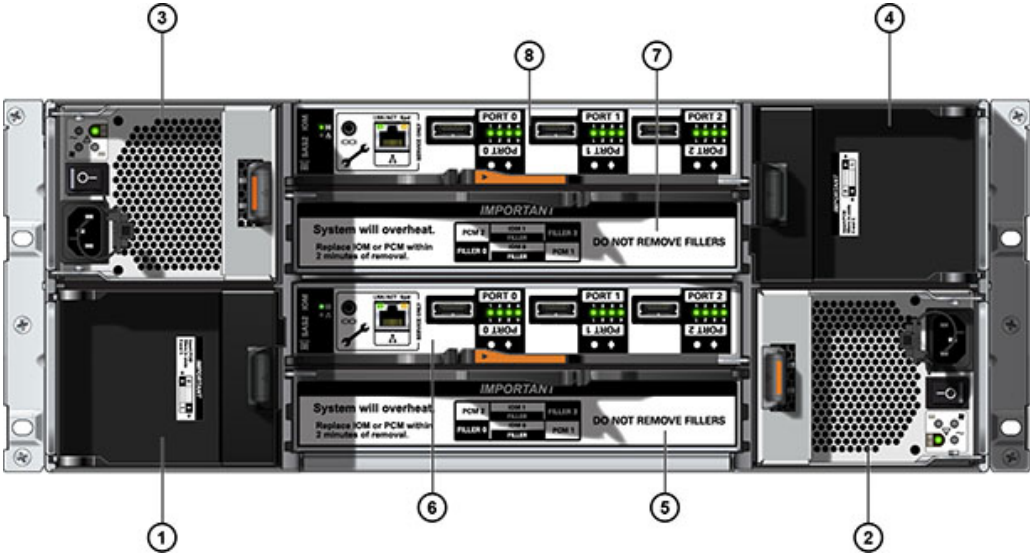

Figure Legend

1 Power supply filler panel, slot 0	2 Power supply with fan module 1	3 Power supply with fan module 2
4 Power supply filler panel, slot 3	5 I/O Module filler panel	6 I/O Module 0
7 I/O Module filler panel	8 I/O Module 1	

Note - It is especially important that power supplies and their filler panels are in the correct slots.

FIGURE 15 DE2 I/O Module Indicators

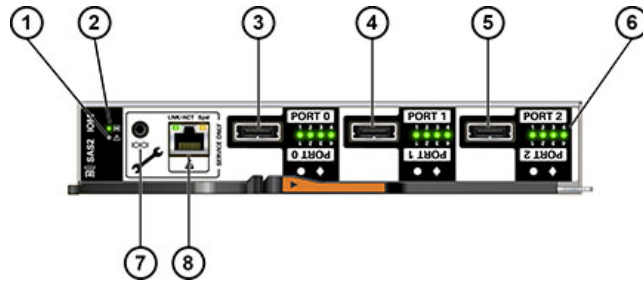

Figure Legend

1 Fault/Locate indicator	2 Power/OK indicator	3 SAS-2 Port 0
4 SAS-2 Port 1	5 SAS-2 Port 2	6 Host port activity indicators
7 For Oracle service only	8 For Oracle service only	

The DE2-24C and DE2-24P disk shelves use the same I/O Module.

FIGURE 16 DE2 Power Supply Indicators

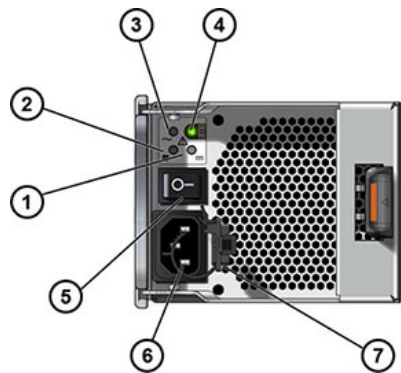

Figure Legend		
1 DC power fail indicator	2 Fan fail indicator	3 AC power fail indicator
4 Power supply status indicator	5 Power on/off switch	6 Universal power input connector
7 Power cord tie wrap		

The DE2-24C and DE2-24P disk shelves use the same power supply.

Sun Disk Shelf

The Sun Disk Shelf is a 4U chassis that supports 24 3.5" SAS-2 drives. The SSDs provide accelerated write operations, and the high-capacity HDDs provide reliable storage. This disk shelf features dual, redundant SAS Interface Module (SIM) boards, and dual power supply with fan modules.

FIGURE 17 Sun Disk Shelf Drive Locations (Front View)

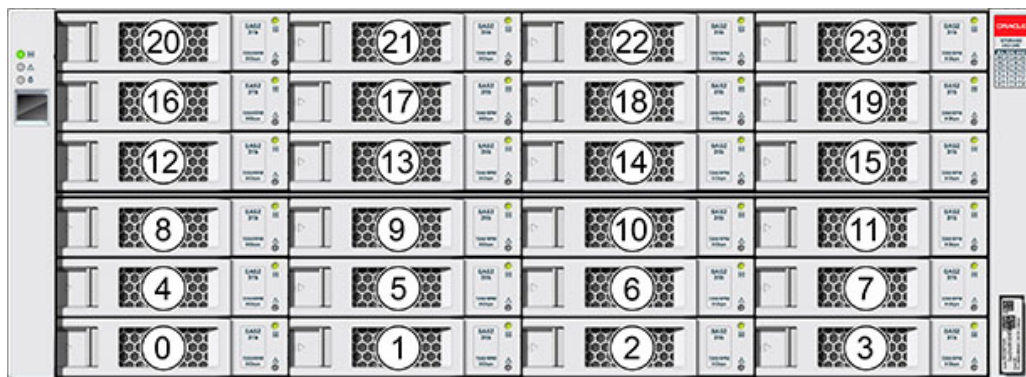

Read cache devices cannot be installed in the Sun Disk Shelf.

FIGURE 18 Sun Disk Shelf Status Indicators (Front View)

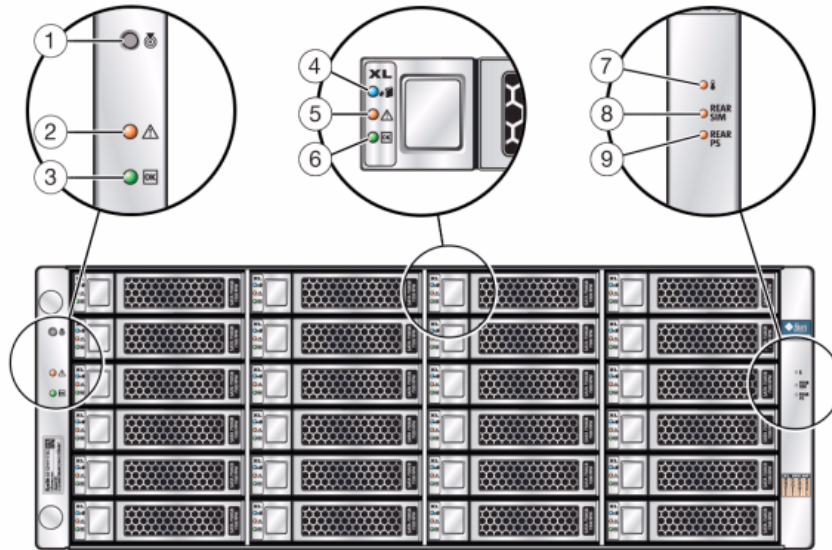

Figure Legend

1 Locate button and indicator	2 System fault indicator	3 System power indicator
4 Disk ready to be removed indicator	5 Disk fault indicator	6 Disk activity indicator
7 Over temperature warning indicator	8 SIM board fault indicator	9 Power supply fault indicator

FIGURE 19 Sun Disk Shelf Rear Panel

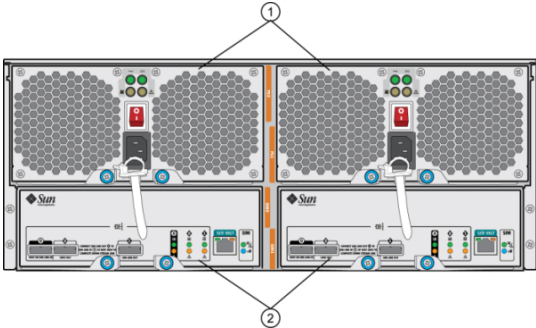

Figure Legend

- | | |
|---|--|
| 1 Power supply modules with built-in fans. Power supply 0 is on the left and power supply 1 is on the right. | 2 Removable SAS Interface Module (SIM) Boards. SIM 0 is on the left, and SIM 1 is on the right. |
|---|--|

FIGURE 20 Sun Disk Shelf SIM Board Indicators

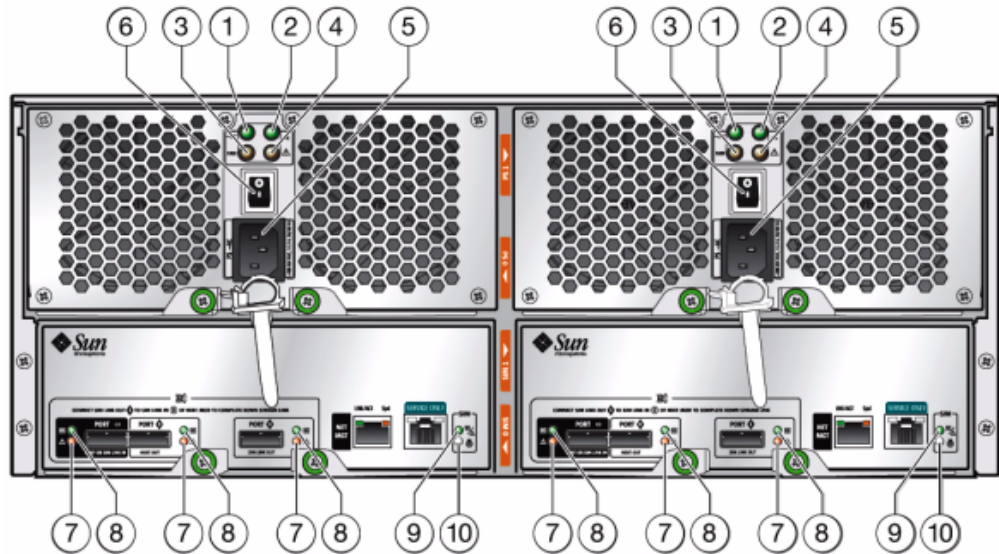
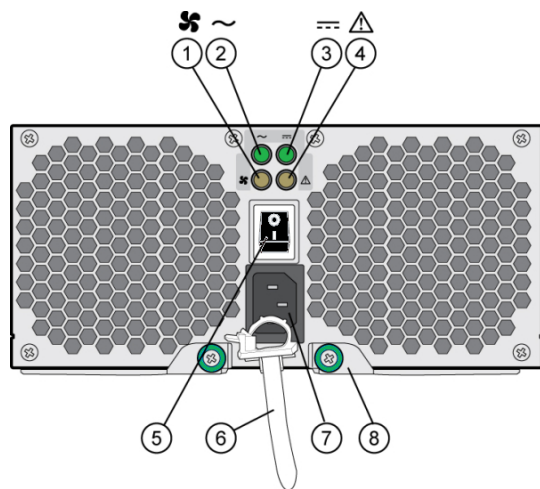

Figure Legend

1 AC power indicator	2 DC power indicator	3 Fan fault indicator
4 Power supply fault indicator	5 Universal power connector	6 Power switch
7 Port fault indicator	8 Port OK indicator	9 SIM board OK indicator (green)/ SIM board fault indicator (amber)
10 SIM locator indicator		

FIGURE 21 Sun Disk Shelf Power Supply and Fan Module Indicators**Figure Legend**

1 Cooling fan status indicator	2 AC power status indicator	3 DC power status indicator
4 Power supply status indicator	5 Power on/off switch	6 Power cord tie wrap
7 Universal power input connector	8 Right ejection arm and captive screw latch	

Disk Shelf Components

The following sections describe each disk shelf's components:

Oracle Storage Drive Enclosure DE3-24P Components

- Drive Enclosure DE3-24P Base Chassis
- Filler Panel, Drive Enclosure DE3-24P
- Up to 24 2.5" SAS-3 HDDs, SSDs. For information about supported HDDs and SSDs, see the [Oracle Systems Handbook](#).

Oracle Storage Drive Enclosure DE3-24C Components

- Drive Enclosure DE3-24C Base Chassis
- Filler Panel, Drive Enclosure DE3-24C

- Up to 24 3.5" SAS-3 HDDs, SSDs. For information about supported HDDs and SSDs, see the [Oracle Systems Handbook](#).

Oracle Storage Drive Enclosure DE2-24P Components

- Drive Enclosure DE2-24P Base Chassis
- Filler Panel, Drive Enclosure DE2-24P
- Up to 24 2.5" SAS-2 or SAS-3 HDDs, SSDs. For information about supported HDDs and SSDs, see the [Oracle Systems Handbook](#).

Oracle Storage Drive Enclosure DE2-24C Components

- Drive Enclosure DE2-24C Base Chassis
- Filler Panel, Drive Enclosure DE2-24C
- Up to 24 3.5" SAS-2 or SAS-3 HDDs, SSDs. For information about supported HDDs and SSDs, see the [Oracle Systems Handbook](#).

Sun Disk Shelf (DS2) Components

- Sun Disk Shelf (DS2) 24x3.5" SAS-2
- Sun Disk Shelf (DS2) 24x3.5", LOGFiller
- Disk Shelf Rail Kit
- Up to 24 3.5" SAS-2 HDDs, SSDs. For information about supported HDDs and SSDs, see the [Oracle Systems Handbook](#).

Overview of ZS7-2 Controller

This section provides an overview of the Oracle ZFS Storage ZS7-2 controller. For installation instructions, refer to “[Installing a ZS7-2 Controller](#)” on page 109. For service instructions, refer to “[Servicing the ZS7-2 Controller](#)” in *Oracle ZFS Storage Appliance Customer Service Manual*.

Refer to <http://oracle.com/zfsstorage> for the most recent component specification.

ZS7-2 Physical Specifications

The ZS7-2 controller chassis dimensions are as follows:

Dimension	Measurement	Dimension	Measurement
Height	3.42 in./8.69 cm	Depth	29.9 in./75.9 cm

Dimension	Measurement	Dimension	Measurement
Width	17.5 in./44.5 cm	Weight (Maximum)	63 lb./28.6 kg

ZS7-2 Electrical Specifications

The ZS7-2 controller has two hot-swappable rear accessible power supplies with N+N redundancy. To understand the overall power consumption, see Oracle's online power calculator at <http://www.oracle.com/goto/powercalculators>.

Parameter	AC Power Supplies
Nominal input frequencies	50/60 Hz
Operating input voltage range	100-240 VAC
Rated input current	10 A @ 100 to 127 VAC and 7 A @ 200 to 240 VAC
Maximum power consumption of controller	Refer to the Power Calculator (https://www.oracle.com/goto/powercalculators) and see Oracle Server X7-2L for Watt calculations
Maximum heat output of controller	Refer to the Power Calculator (https://www.oracle.com/goto/powercalculators) and see Oracle Server X7-2L for BTU/hr calculations

ZS7-2 Acoustic Noise Emissions

The workplace-dependent noise level of this product is 8.1 Bels A-weighted Operating, and 5.8 Bels A-weighted Idling (measured Sound Power).

ZS7-2 Configuration Options

The ZS7-2 high-end model incorporates one or two controllers and one to forty-eight disk shelves. Each controller has 11 PCIe Gen3 slots in the rear, and 12 3.5" disk slots in the front, two of which are occupied by system disks. Read cache devices are installed in disk shelves; therefore, the remaining ten front disk slots have permanent filler panels. The following table describes the configuration options.

CPU	Memory	System Disks	PCIe Slots	HBA
2x24-core, 2.1 GHz	1.5 TB	2x3.5" SAS-3	Six dedicated; five available	4-port (4x4) SAS-3 12 Gb/s external

The ZS7-2 mid-range model incorporates one or two controllers and one to sixteen disk shelves. Each controller has 11 PCIe Gen3 slots in the rear, and 12 3.5" disk slots in the front, two of which are occupied by system disks. Read cache devices are installed in disk shelves; therefore, the remaining ten front disk slots have permanent filler panels. The following table describes the configuration options.

CPU	Memory	System Disks	PCIe Slots	HBA
2x18-core, 2.3 GHz	512 GB or 1024 GB	2x3.5" SAS-3	Four dedicated; five available; two unavailable (permanent filler panels)	4-port (4x4) SAS-3 12 Gb/s external

The most recent component specification is located at <https://www.oracle.com/storage/nas/index.html>.

ZS7-2 Front Panel Components

The ZS7-2 controller drive slots and front panel components are shown in the following figure.

FIGURE 22 ZS7-2 Front Panel

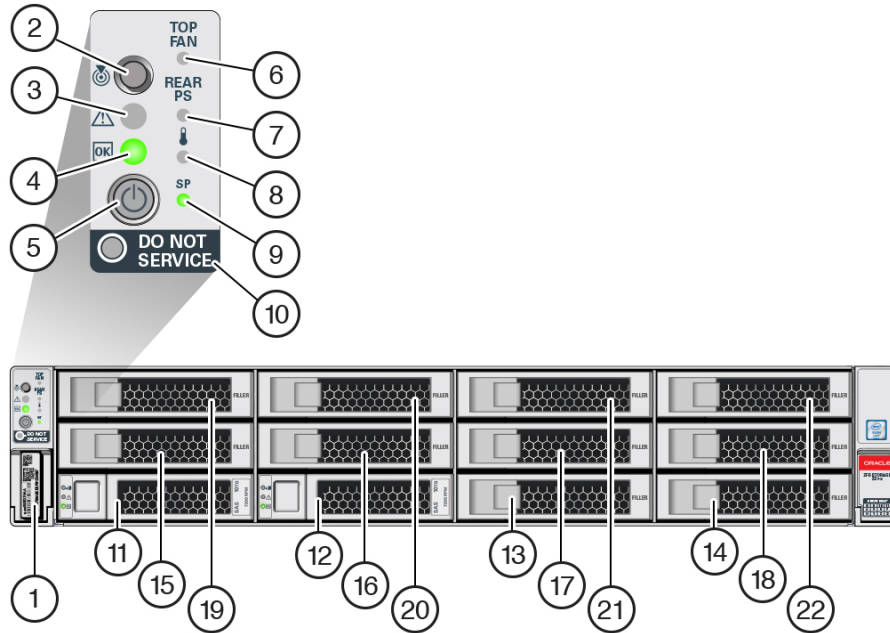

1 RFID tag	2 System status LED: Locator (white)	3 System status LED: Service Action Required (amber)
4 System status LED: Power/OK (green)	5 Power button	6 Fan service action required (amber)
7 Power Supply (PS) service action required (amber)	8 Over-temperature warning (amber)	9 Service Processor (SP) OK (green)
10 Do Not Service indicator	11 System disk 0	12 System disk 1
13 Filler panel	14 Filler panel	15 Filler panel
16 Filler panel	17 Filler panel	18 Filler panel
19 Filler panel	20 Filler panel	21 Filler panel
22 Filler panel		

ZS7-2 Rear Panel Components

The ZS7-2 controller PCIe slots and rear panel components are shown in the following figure.

FIGURE 23 ZS7-2 Rear Panel

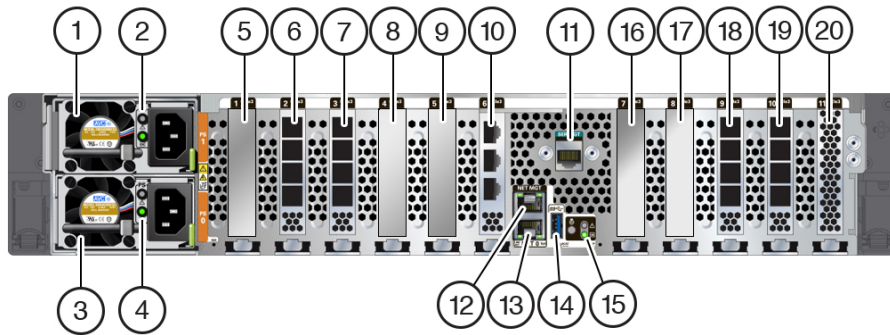

1 Power Supply Unit (PSU) 1	2 PSU 1 status indicators (top to bottom): <ul style="list-style-type: none"> ■ Attention (amber) ■ Power/OK (green) 	3 PSU 0
4 PSU 0 status indicators (top to bottom): <ul style="list-style-type: none"> ■ Attention (amber) ■ Power/OK (green) 	5 Fifth PCIe option (slot 1)	6 External SAS-3 HBA (slot 2)
7 Slot 3: <ul style="list-style-type: none"> ■ High-end model: External SAS-3 HBA ■ Mid-range model: Filler panel 	8 First PCIe option (slot 4)	9 Third PCIe option (slot 5)
10 Cluster interface card (slot 6)	11 Serial management (SER MGT) RJ-45 serial port	12 Service Processor (SP) NET MGT port
13 Network (NET) 100/1000BASE-T RJ-45 Gigabit Ethernet (GbE) port: NET 0	14 USB 3.0 port	15 System status LEDs: <ul style="list-style-type: none"> ■ Locate (white) - left ■ Attention (amber) - right, top ■ Power/OK (green) - right, bottom

16 Fourth PCIe option (slot 7)	17 Second PCIe option (slot 8)	18 Slot 9: <ul style="list-style-type: none"> ■ High-end model: External SAS-3 HBA ■ Mid-range model: Filler panel
19 External SAS-3 HBA (slot 10)	20 Internal SAS-3 HBA (slot 11)	

For information about how to connect cables to form a cluster, see [“Connecting Cluster Cables” in Oracle ZFS Storage Appliance Cabling Guide](#).

Overview of ZS5-4 Controller

This section provides an overview of the Oracle ZFS Storage ZS5-4 controller. For installation instructions, refer to [“Installing a ZS5-4 Controller” on page 123](#). For service instructions, refer to [“Servicing the ZS5-4 Controller” in Oracle ZFS Storage Appliance Customer Service Manual](#).

Refer to <http://oracle.com/zfsstorage> for the most recent component specification.

ZS5-4 Physical Specifications

The ZS5-4 controller chassis dimensions are as follows:

Dimension	Measurement	Dimension	Measurement
Height	5.1 in./129.9 mm	Depth	28.8 in./732.0 mm
Width	17.2 in./436.5 mm	Weight (Maximum)	88 lb./40 kg

ZS5-4 Electrical Specifications

The ZS5-4 controller has two hot-swappable rear accessible power supplies with N+N redundancy. To understand the overall power consumption, see Oracle’s online power calculator at <http://www.oracle.com/goto/powercalculators>.

Parameter	AC Power Supplies
Nominal input frequencies	50/60 Hz

Parameter	AC Power Supplies
Operating input voltage range	200-240 VAC
Rated input current	10 A @ 200 to 240 VAC
Maximum power consumption	200W
Maximum heat output	6824 BTU/hr

ZS5-4 Acoustic Noise Emissions

In compliance with the requirements defined in ISO 9296, the workplace-dependent noise level of this product is less than 75 dBA (bystander position, max. ambient).

ZS5-4 Configuration Options

The ZS5-4 incorporates one or two controllers and one to forty-eight disk shelves. Each controller has eleven PCIe Gen3 slots. Each controller includes six 2.5" disk slots that accommodate two system disks. Read cache devices are installed in disk shelves; therefore, the remaining four disk slots have permanent filler panels. The following table describes the configuration options.

CPU	Memory	System Disks	PCIe Slots	HBA
4x18-core, 2.6 GHz	1536 GB	2x2.5" SAS-3	Four dedicated; seven available	4-port (4x4) SAS-3 12 Gb/s external 4-port (4x4) SAS-2 6 Gb/s external

The most recent component specification is located at <https://www.oracle.com/storage/nas/index.html>.

ZS5-4 Front Panel Components

The ZS5-4 controller drive slots and front panel components are shown in the following figure.

FIGURE 24 ZS5-4 Front Panel

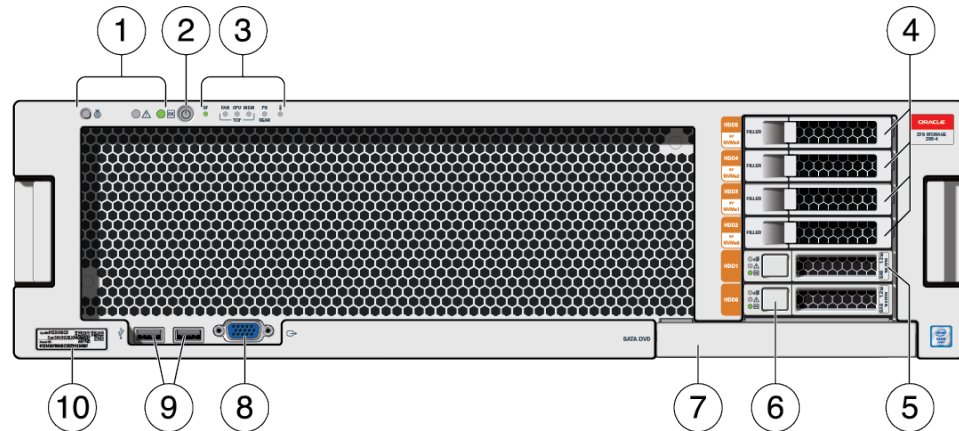

<p>1 LEDs (left to right)</p> <ul style="list-style-type: none"> ■ Locator ■ Service action required ■ Power/OK 	<p>2 Power button</p>	<p>3 Alert indicators (left to right)</p> <ul style="list-style-type: none"> ■ Service Processor (SP) OK/Fault ■ Fan/ CPU/ Memory service action required ■ Power Supply (PS) service action required ■ Over-temperature warning
<p>4 Permanent HDD filler panels</p>	<p>5 System disk 1</p>	<p>6 System disk 0</p>
<p>7 DVD filler panel</p>	<p>8 DB-15 VGA port</p>	<p>9 Two USB 2.0 ports</p>
<p>10 RFID tag</p>		

ZS5-4 Rear Panel Components

The ZS5-4 controller PCIe slots and rear panel components are shown in the following figure.

FIGURE 25 ZS5-4 Rear Panel

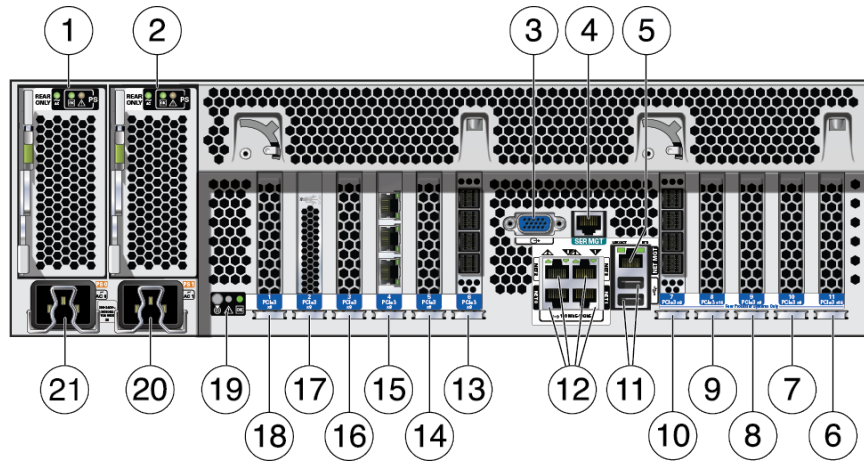

1 Power Supply Unit (PSU) 0	2 PSU 1	3 DB-15 VGA port
4 SER MGT port	5 Service Processor (SP) NET MGT port	6 First PCIe (slot 11)
7 Fifth PCIe (slot 10)	8 Third 4x4 SAS HBA or seventh PCIe (slot 9)	9 Second PCIe (slot 8)
10 4X4 SAS HBA (slot 7)	11 Two USB 2.0 ports	12 Network (NET) 10 Gb Ethernet ports, NET 0 - NET 3
13 4X4 SAS HBA (slot 6)	14 Third PCIe (slot 5)	15 Cluster interface card (slot 4)
16 Fourth 4X4 SAS HBA or sixth PCIe (slot 3)	17 Internal SAS-3 HBA (slot 2)	18 Fourth PCIe (slot 1)
19 System status LEDs (left to right)	20 PSU 1 AC inlet	21 PSU 0 AC inlet
<ul style="list-style-type: none"> ■ Power/OK (green) ■ Attention (amber) ■ Locate (white) 		

Cluster Interface Card Compatibility - The ZS5-4 controller contains a Version 3 cluster interface card, which is incompatible with Version 2.

For information about how to connect cables to form a cluster, see [“Connecting Cluster Cables” in Oracle ZFS Storage Appliance Cabling Guide](#).

Overview of ZS5-2 Controller

This section provides an overview of the Oracle ZFS Storage ZS5-2 controller. For installation instructions, refer to [“Installing a ZS5-2 Controller” on page 133](#). For service instructions, refer to [“Servicing the ZS5-2 Controller” in Oracle ZFS Storage Appliance Customer Service Manual](#).

Refer to <http://oracle.com/zfsstorage> for the most recent component specification.

ZS5-2 Physical Specifications

The ZS5-2 controller chassis dimensions are as follows:

Dimension	Measurement	Dimension	Measurement
Height	3.43 in./87.1 mm	Depth	25.2 in./640.0 mm
Width	17.52 in./445 mm	Weight	38.5 lb./17.5 kg

ZS5-2 Electrical Specifications

The ZS5-2 controller has two N+1 AC redundant hot-swappable AC power supplies, rated 91% efficiency. To understand the overall power consumption, see Oracle's online power calculator at <http://www.oracle.com/goto/powercalculators>.

Parameter	AC Power Supplies
Nominal input frequencies	50/60 Hz
Operating input voltage range	100 VAC (Japan only) 110-127 VAC (90-132 range) 200-240 VAC (180-264 range)
Rated input current	10 A @ 100 VAC 9 A @110-127 VAC 5.5 A @ 200-240 VAC

ZS5-2 Acoustic Noise Emissions

In compliance with the requirements defined in ISO 9296, the workplace-dependent noise level of this product is less than 75 dBA.

ZS5-2 Configuration Options

The ZS5-2 incorporates one or two controllers and one to sixteen disk shelves. Each controller has six PCIe Gen3 slots. Each controller includes eight 2.5" disk slots that accommodate two system disks. Read cache devices are installed in disk shelves; therefore, the remaining six disk slots have permanent filler panels. The following table describes the configuration options.

CPU	Memory	System Disks	PCIe Slots	HBA
2x18-core, 2.3 GHz	384 GB 768 GB	2x2.5" SAS-3	Two dedicated; four available	4-port (4x4) SAS-3 12 Gb/s external 4-port (4x4) SAS-2 6 Gb/s external

Refer to <http://oracle.com/zfsstorage> for the most recent component specification.

ZS5-2 Front Panel Components

The ZS5-2 controller drive slots and front panel components are shown in the following figure.

FIGURE 26 ZS5-2 Front Panel

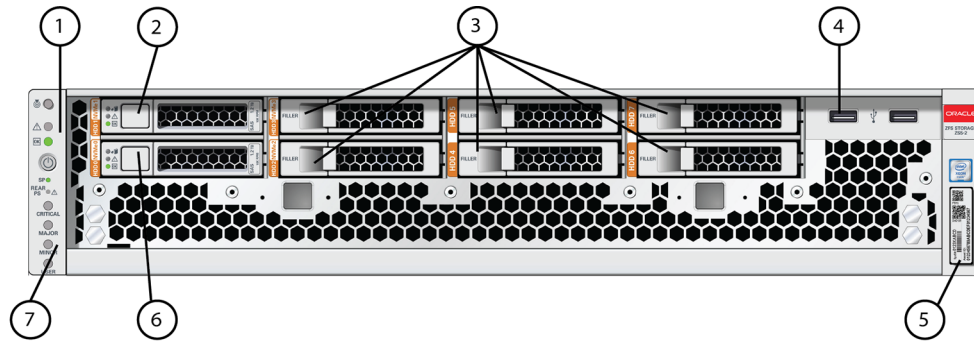

1 LEDs: Locator, Service, Power	2 System disk 1	3 Permanent HDD filler panels
4 Two USB 2.0 ports	5 RFID tag	6 System disk 0
7 Alarm indicators (not used)		

ZS5-2 Rear Panel Components

The ZS5-2 controller PCIe slots and rear panel components are shown in the following figure.

FIGURE 27 ZS5-2 Rear Panel

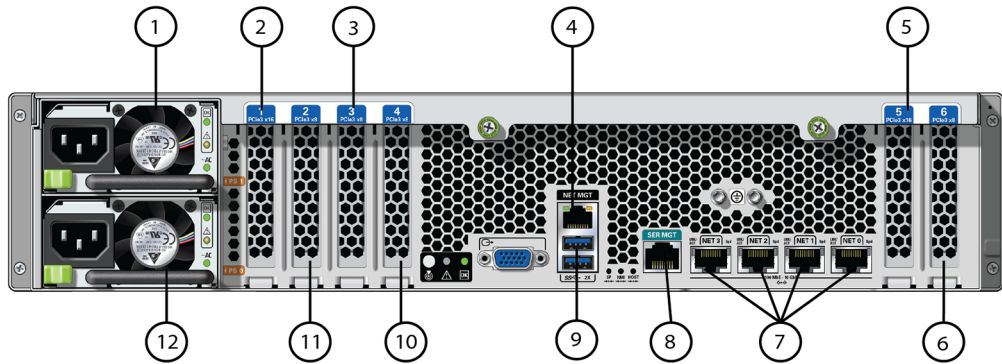

1 Power Supply Unit (PSU) 1	2 Second PCIe option (slot 1)	3 Third PCIe option (slot 3)
4 Network Management (NET MGT) 10/100/1000 BASE-T Ethernet port	5 First PCIe option (slot 5)	6 Second 4x4 SAS HBA, or fourth PCIe option (slot 6)
7 Network (NET) 10 GbE ports: NET 0, NET 1, NET 2, NET 3	8 SER MGT port	9 Two USB 3.0 ports
10 Cluster interface card (slot 4)	11 First 4x4 SAS HBA (slot 2)	12 Power Supply Unit (PSU) 0

Cluster Interface Card Compatibility - The ZS5-2 controller contains a Version 3 cluster interface card, which is incompatible with Version 2.

For information about how to connect cables to form a cluster, see [“Connecting Cluster Cables” in Oracle ZFS Storage Appliance Cabling Guide](#).

Cable Management Arm

The following figure identifies the components of the cable management arm (CMA). For installation instructions, see [“Installing a ZS5-2 Cable Management Arm” on page 140](#).

FIGURE 28 ZS5-2 Controller Cable Management Arm

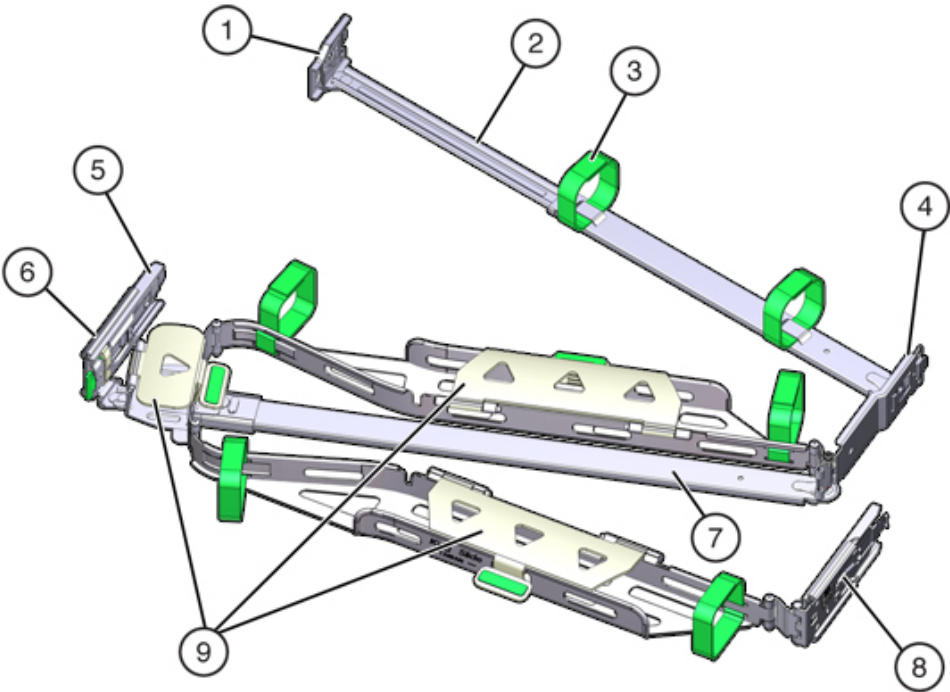

Figure Legend	
1 Connector A	6 Connector D
2 Front slide bar	7 Slide-rail latching bracket (used with connector D)
3 Velcro straps (6)	8 Rear slide bar
4 Connector B	9 Cable covers
5 Connector C	

Overview of ZS4-4 Controller

This section provides an overview of the Oracle ZFS Storage ZS4-4 controller. For installation instructions, refer to “Installing a ZS4-4 or ZS3-4 Controller” on page 151. For service instructions, refer to “Servicing the ZS4-4 Controller” in *Oracle ZFS Storage Appliance Customer Service Manual*.

Refer to <http://oracle.com/zfsstorage> for the most recent component specification.

ZS4-4 Front Panel Components

The ZS4-4 controller drive slots and front panel components are shown in the following figure.

FIGURE 29 ZS4-4 Controller Front Panel

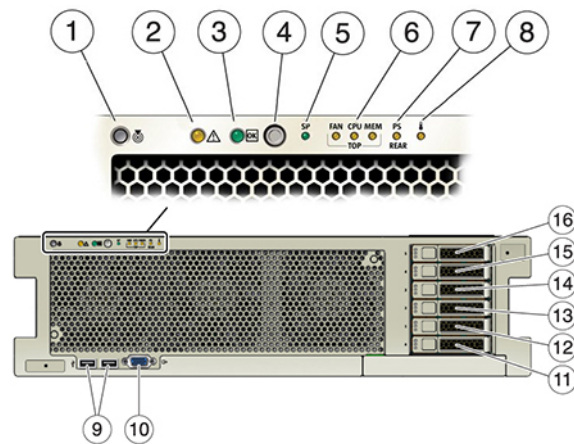

Figure Legend

1 Locator LED/button (white)	2 Service action required LED (amber)	3 Power/OK LED (green)
4 Power button	5 Service Processor (SP) OK (green) /Fault (amber) LED	6 Fan/CPU/Memory Service action required LED (amber)
7 Power Supply (PS) Service action required LED (amber)	8 Over temperature warning LED (amber)	9 USB 2.0 connectors (2)

Figure Legend		
10 DB-15 video port	11 Boot drive 0 (required)	12 Boot drive 1 (required)
13 Solid state drive 2 (optional)	14 Solid state drive 3 (optional)	15 Solid state drive 4 (optional)
16 Solid state drive 5 (optional)		

The ZS4-4 controller has two 2.5-inch SAS system boot drives in slots 0 and 1, configured as a mirrored pair. Up to four SAS read cache SSDs can fill slots 2 through 5, in that order. A filler panel must be installed in empty drive slots. For information about supported HDDs and SSDs, see the [Oracle Systems Handbook](#).

The system boot drive LEDs are shown in the following figure.

FIGURE 30 System Boot Drive LEDs



TABLE 5 System Boot Drive LEDs

Figure Legend		
1 Ready to remove (blue)	2 Service action required (amber)	3 OK/Activity (green)

ZS4-4 Rear Panel Components

The ZS4-4 rear panel is shown in the following figure. Base configuration PCIe cards are not depicted in this illustration. For more information about PCIe cards, see “[ZS4-4 PCIe I/O Cards](#)” in *Oracle ZFS Storage Appliance Customer Service Manual*.

FIGURE 31 ZS4-4 Controller Rear Panel

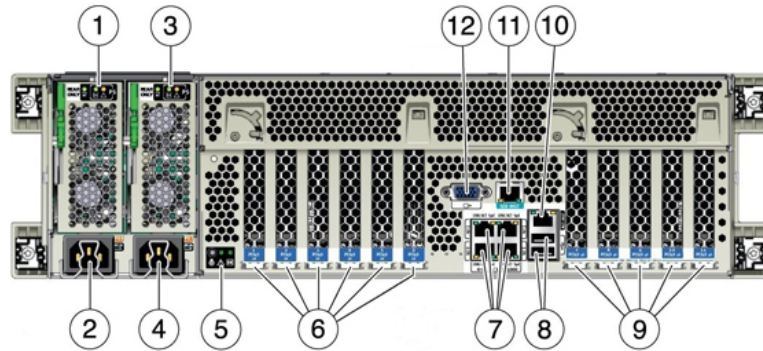

Figure Legend

1 Power supply unit (PSU) 0 indicator panel	2 PSU 0 AC inlet	3 PSU 1 indicator panel
4 PSU 1 AC inlet	5 System status indicator panel	6 PCIe card slots 1-6
7 Network (NET) 10 GbE ports: NET 0, NET 1, NET 2, NET 3	8 USB 2.0 connectors (2)	9 PCIe card slots 7-11
10 Network management (NET MGT) 10/100/1000 BASE-T Ethernet port	11 Serial management (SER MGT) RJ-45 port	12 DB-15 video port

- **PCIe Slots** - The ZS4-4 base configuration contains the following PCIe cards:
 - Slot 2 - One 8-port SAS-2 internal HBA
 - Slot 4 - One cluster interface card
 - Slots 6 and 7 - Two 4-port (4x4) SAS external HBAs

For information about PCIe slot order, see [“ZS4-4 PCIe I/O Cards”](#) in *Oracle ZFS Storage Appliance Customer Service Manual*.

- **Ethernet Ports** - The ZS4-4 has four RJ-45 10-Gigabit Ethernet (10GbE) network connectors on the rear panel, labeled NET 0, NET 1, NET 2, and NET 3 (bottom left to top right), as shown in the following figure. Use these ports to connect the appliance to the network.

The LEDs located above the NET ports, labeled 2, 0, 3, 1 (left to right) are Link/Activity indicators.

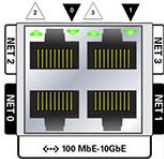

LED	Status
OFF (1)	No Link
ON (0)	Link and no activity
Blink	Link and activity

Note - Speed is not indicated for the NET ports.

- Network Management Port** - The network management connector (NET MGT) is an RJ-45 10/100/1000 BASE-T Ethernet port and provides an alternate terminal interface to the service processor (SP) console.



- Serial Management Port** - The serial management connector (SER MGT) is an RJ-45 port and provides a terminal connection to the SP console.



- HBA Ports** - The 4x4 SAS HBA provides connectivity to external DEx-24 disk shelves. The HBA logical ports are numbered 0-3, bottom to top.



Overview of ZS3-4 Controller

This section provides an overview of the Oracle ZFS Storage ZS3-4 controller. For installation instructions, refer to “Installing a ZS4-4 or ZS3-4 Controller” on page 151. For service instructions, refer to “Servicing the ZS3-4 Controller” in *Oracle ZFS Storage Appliance Customer Service Manual*.

ZS3-4 Electrical Specifications

The following list shows the electrical specifications for the ZS3-4 controller.

Note - The power dissipation numbers listed are the maximum rated power numbers for the power supply. The numbers are not a rating of the actual power consumption of the appliance.

Input

- Nominal frequencies: 50/60Hz
- AC operating range: 200-240 VAC
- Maximum current AC RMS: 12A @ 200 VAC

Power Dissipation

- Max power consumption: 1800 W
- Max heat output: 6143 BTU/hr
- Volt-Ampere rating: 1837 VA @ 240 VAC, 0.98 P.F.

ZS3-4 Configuration Options

The ZS3-4 controller can be configured as a single controller or two controllers to create a high-availability cluster configuration. The following table describes the configuration options:

CPU	Memory	Readzilla SAS-2	Boot Drive SAS-2	HBA SAS-2
4x10-core, 2.40GHz	1TB (16GB DIMMs)	Four SSDs	Two HDDs	4-port (4X4) SAS-2 6Gb/s external

Refer to <http://oracle.com/zfsstorage> for the most recent component specification.

ZS3-4 Front Panel Components

FIGURE 32 ZS3-4 Front Panel

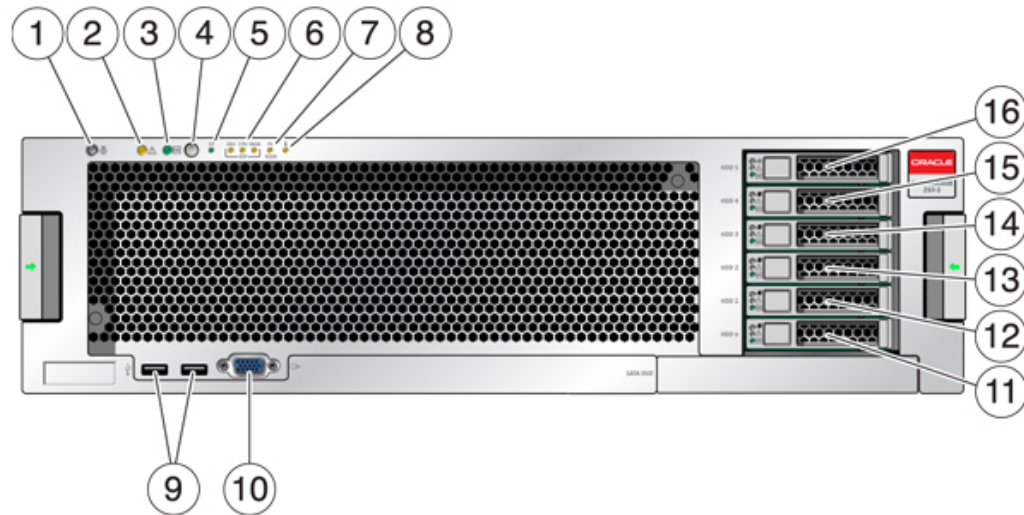

Figure Legend

1 Locator LED and button (white)	2 Service Required LED (amber)	3 Power/OK LED (green)
4 Power button	5 Service Processor (SP) OK LED (green)	6 Fan/CPU/Memory Service Required LED
7 Power Supply (PS) Service Required LED	8 Over Temperature Warning LED	9 USB 2.0 Connectors
10 DB-15 video connector	11 Boot drive 0 (required)	12 Boot drive 1 (required)
13 Solid state drive 2 (optional)	14 Solid state drive 3 (optional)	15 Solid state drive 4 (optional)
16 Solid state drive 5 (optional)		

The ZS3-4 controller has two SAS-2 system boot drives in slots 0 and 1, configured as a mirrored pair. Up to four SAS-2 read cache SSDs can fill slots 2 through 5, in order. For information about supported HDDs and SSDs, see the [Oracle Systems Handbook](#).

FIGURE 33 System Boot Drive LEDs



Figure Legend

1 Ready to remove (blue)	2 Service action required (amber)	3 OK/Activity (green)
--------------------------	-----------------------------------	-----------------------

ZS3-4 Rear Panel Components

The following graphic shows the rear panel of the ZS3-4 controller. Base configuration HBAs are not depicted in this illustration.

For information about PCIe cards, see [“ZS3-4 PCIe I/O Cards”](#) in *Oracle ZFS Storage Appliance Customer Service Manual*.

FIGURE 34 ZS3-4 Rear Panel Components

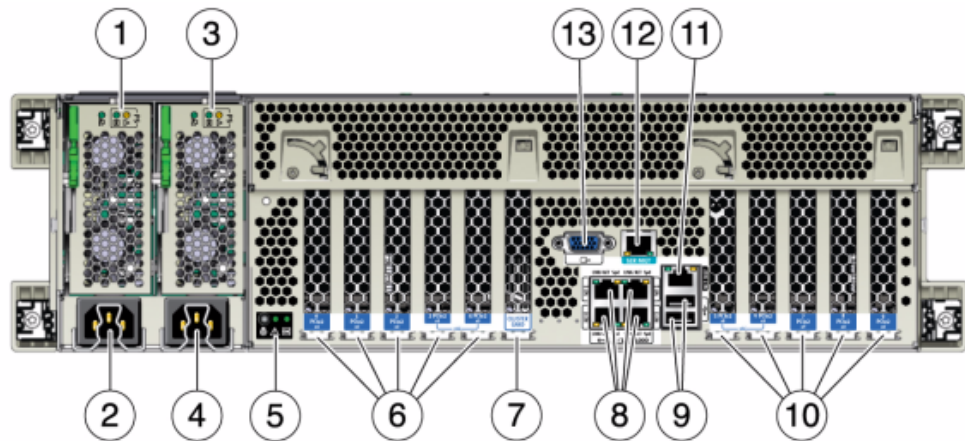
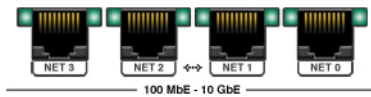

Figure Legend

1 Power supply unit 0 status LEDs OK: green Power Supply Fail: amber AC OK: green	2 Power supply unit 0 AC inlet	3 Power supply unit 1 status LEDs OK: green Power Supply Fail: amber AC OK: green
4 Power supply unit 1 AC inlet	5 System status LEDs Power: green Attention: amber Locate: white	6 PCIe slots 0-4
7 Cluster card slot	8 Network (NET) 10/100/1000 ports: NET 0-NET 3	9 USB 2.0 ports
10 PCIe slots 5-9	11 Network management (NET MGT) 10/100 BASE-T Ethernet port	12 Serial management (SER MGT) port
13 DB-15 video connector		

- **Ethernet Ports** - The ZS3-4 has four RJ-45 Gigabit Ethernet connectors (NET 0, NET 1, NET 2, NET 3) located on the motherboard that operate at 10/100/1000 Mbit/sec. These network interfaces must be configured before use.



- **Network Management Port** - The network management connector (NET MGT) is an RJ-45 10/100 BASE-T Ethernet port and provides a LAN interface to the SP console.



- **Serial Management Port** - The serial management connector (SER MGT) is an RJ-45 connector and provides a terminal connection to the SP console.



- **HBA Ports** - The 4x4 SAS-2 HBA, installed in the ZS3-4, provides connectivity to external DE2 and Sun Disk Shelves. The HBA logical ports are numbered 3-0, top to bottom:

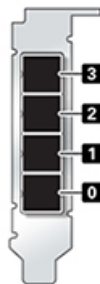

Overview of ZS3-2 Controller

This section provides an overview of the Oracle ZFS Storage ZS3-2 controller. For installation instructions, refer to [“Installing a ZS3-2 Controller” on page 161](#). For service instructions, refer to [“Servicing the ZS3-2 Controller” in Oracle ZFS Storage Appliance Customer Service Manual](#).

ZS3-2 Physical Specifications

The ZS3-2 controller 2U chassis dimensions are as follows:

Dimension	Measurement	Dimension	Measurement
Height	3.44 in./87.4 mm	Depth	20.25 in./514 mm
Width	17.52 in./445 mm	Weight	41.23 lb/18.70 kg

ZS3-2 Electrical Specifications

The ZS3-2 controller electrical specifications are listed below. The power dissipation numbers listed are the **maximum** rated power numbers for the power supply. The numbers are not a rating of the actual power consumption of the appliance.

Connectors

- Two C13 connectors, which work on 110-220v outlets

Input

- Nominal frequencies: 50/60Hz (47 to 63 Hz range)
- Nominal voltage range: 100 to 120/200 to 240 VAC
- Maximum current AC RMS: 6.8 A @ 100-120 V / 3.4 A @ 200-240 V
- AC operating range: 90-264 VAC

Output

- 3.3 VDC STBY: 3.0A
- +12 VDC: 86.7A

Power Dissipation

- Max power consumption: 890 W max
- Max heat output: 3026 BTU/hr
- Volt-Ampere rating: 908 VA @ 240 VAC, 0.98P.F.

ZS3-2 Acoustic Noise Emissions

In compliance with the requirements defined in ISO 7779, the workplace-dependent noise level of this product is less than 70 db (A).

ZS3-2 Configuration Options

The ZS3-2 controller is an enterprise-class, rackmount x86 system powered by the Intel Xeon processor. It provides high performance and room for growth with expandable PCIe slots and 16 DIMM slots in a compact 2U footprint. The following table describes the configuration options.

CPU	Memory	Readzilla	Boot Drive	PCIe Slots	HBA
2x8-core, 2.1 GHz	256GB	1-4 SAS SSDs	Two 2.5-inch SAS HDDs	Two dedicated; four available	4-port (4x4) SAS-3 12Gb/s external
	512GB 16x32GB				4-port (4x4) SAS-2 6Gb/s external

Refer to <http://oracle.com/zfsstorage> for the most recent component specification.

ZS3-2 Front Panel Components

The ZS3-2 controller drive slots and front panel components are shown in the following figure.

FIGURE 35 ZS3-2 Controller Front Panel

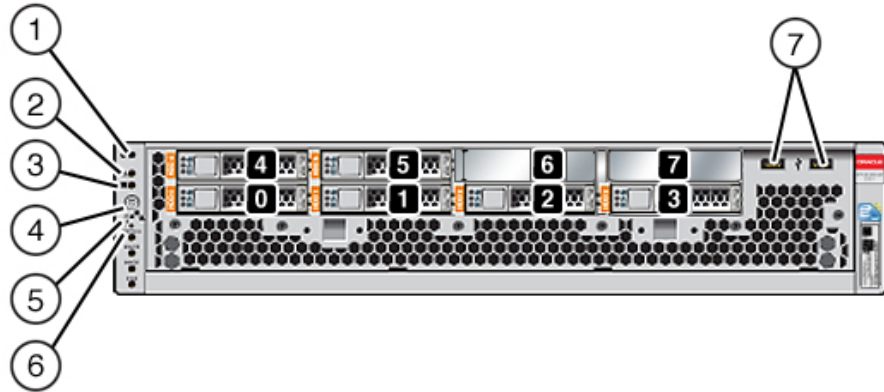

Drive slots 0 and 1 have two mirrored SAS-2 boot drives. Up to four read cache SSDs fill slots 2 through 5, in order. Slots 6 and 7 are empty and must contain drive fillers. For information about supported HDDs and SSDs, see the [Oracle Systems Handbook](#).

Figure Legend

1 Locator LED/button (white)	2 Service Action Required LED (amber)	3 Power OK LED (green)
4 Power button	5 Service Processor OK LED (green)	6 Fan/CPU/Memory Service Required LED
7 USB 2.0 ports		

Note - The LEDs below the Fan/CPU/Memory Service Required LED are not currently used.

ZS3-2 Rear Panel Components

The ZS3-2 controller PCIe slots and rear panel components are shown in the following figure.

For more information about PCIe cards, see “[ZS3-2 PCIe I/O Cards](#)” in *Oracle ZFS Storage Appliance Customer Service Manual*.

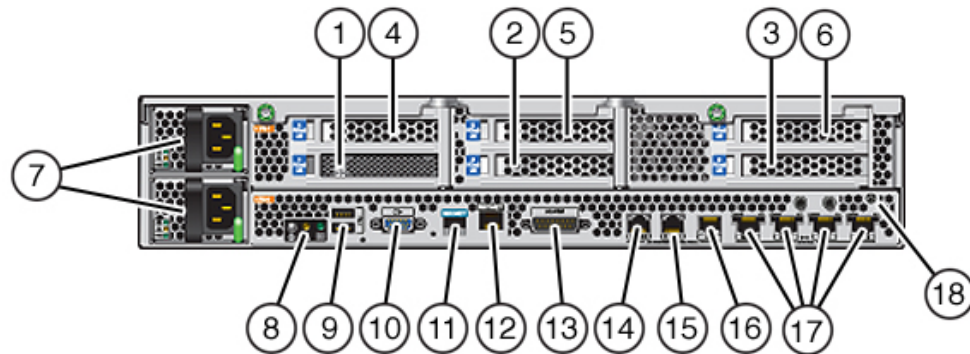
FIGURE 36 ZS3-2 Controller Rear Panel**Figure Legend**

1 SAS-2 internal HBA (slot 1)	2 4x4 SAS external HBA (slot 2)	3 PCIe slot 3
4 PCIe slot 4	5 PCIe slot 5	6 PCIe slot 6
7 AC power supplies PS1 (top), PS0 (bottom)	8 System status LEDs	9 USB 2.0 ports
10 SP 15-pin VGA video port	11 Serial management port	12 Network management (NET MGT) 10/100 BASE-T Ethernet port
13 Alarm port, DB-15 connector (not used for the ZS3-2)	14-16 Cluster I/O ports	17 10-Gbit Ethernet ports
18 Chassis ground post		

Note - The three Cluster I/O ports (0, 1, and GigE) are reserved for cluster interconnection only.

The ZS3-2 controller has the following ports:

- Ethernet Ports** - The ZS3-2 has four RJ-45 10-Gigabit Ethernet (10GbE) network connectors, labeled NET 3, NET 2, NET 1, and NET 0 (left to right) on the rear panel. The ports operate at 100 Mbits/sec, 1000 Mbits/sec, or 10-Gbits/sec. Use these ports to connect the appliance to the network.



The LEDs located above each NET port are Link/Activity (left) and Speed (right) indicators for each port as described in this table:

Connection Type	EEE Terminology	Speed LED Color	Transfer Rate
Fast Ethernet	100BASE-TX	Off	100 Mbts/sec
Gigabit Ethernet	1000BASE-T	Amber	1000 Mbts/sec
10 Gigabit Ethernet	10GBASE-T	Green	10000 Mbts/sec

- Cluster I/O Ports** - Two cluster serial ports (0 and 1) and one Ethernet port provide communication between two controllers to form a cluster configuration. For information about how to connect cables to form a cluster, see [“Connecting Disk Shelf Cables” on page 200](#).



Caution - When disconnecting an RJ-45 cable from a cluster serial port (0 and 1), use extreme care not to damage the internal RJ-45 receptacle. To properly disconnect an RJ-45 cable from a cluster serial port, see [“Disconnecting an RJ-45 Cable” on page 16](#).

- Network Management Port** - The network management connector (NET MGT) is an RJ-45 10/100 BASE-T Ethernet port and provides an alternate terminal interface to the SP console.



- Serial Management Port** - The serial management connector (SER MGT) is an RJ-45 port and provides a terminal connection to the service processor (SP) console.



- HBA Ports** - The 4x4 SAS HBA, installed in PCIe slot 2 of the ZS3-2, provides connectivity to external disk shelves. The HBA logical ports are numbered 0-3, left to right, as shown below:

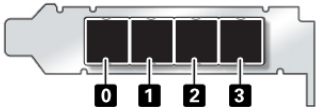

Optional Cable Management Arm

The following figure identifies the components of the second-generation cable management arm (CMA). See the CMA installation instructions.

FIGURE 37 Cable Management Arm Components

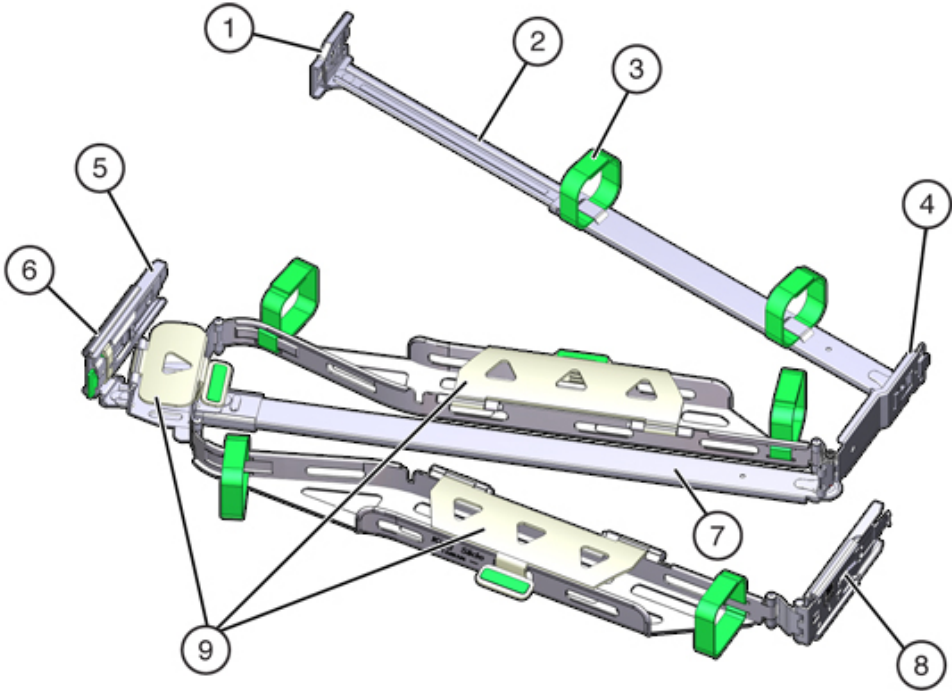

Figure Legend		
1 Connector A	2 Front slide bar	3 Velcro straps (6)

Figure Legend		
4 Connector B	5 Connector C	6 Connector D
7 Slide-rail latching bracket (used with connector D)	8 Rear slide bar	9 Cable covers

Overview of 7420 Controller

This section provides an overview of the Oracle ZFS Storage 7420 controller. For installation instructions, refer to [“Installing a 7x20 Controller” on page 179](#). For service instructions, refer to [“Servicing the 7420 or 7320 Controller” in Oracle ZFS Storage Appliance Customer Service Manual](#).

7420 Physical Specifications

The 7420 controller 3U chassis dimensions are as follows:

Dimension	Measurement	Dimension	Measurement
Height	13.3 cm/5.25 in	Depth	70.6 cm/27.8 in
Width	43.7 cm/17.19 in	Weight	16.36 kg/96 lbs

7420 Electrical Specifications

The following list shows the electrical specifications for the 7420 controller.

Note - The power dissipation numbers listed are the maximum rated for the power supply and are not a rating of the actual power consumption of the appliance.

Input

- Nominal frequencies: 50/60Hz
- AC operating range: 100-127 VAC for 2 CPUs and 200-240 VAC for 2 or 4 CPUs
- Maximum current AC RMS: 12A @ 100 VAC / 12A @ 200 VAC

Power Dissipation

- Max power consumption: 1800 W
- Max heat output: 6143 BTU/hr
- Volt-Ampere rating: 1837 VA @ 240 VAC, 0.98 P.F.

7420 Configuration Options

The Sun ZFS Storage 7420 Appliance consists of a standalone storage controller, or two storage controllers in a high-availability cluster configuration, and one to 36 disk shelves. The following table describes the 7420 configuration options:

Note - 7420 M2 controllers cannot be clustered with 7420 controllers.

Product ID	CPU	DIMMs	Readzilla	Boot Drive
7420 M2	4x8-core, 2.0GHz	8GB, 16GB	1.6TB SAS	900GB SAS
7420 M2	4x10-core, 2.40GHz	8GB, 16GB	1.6TB SAS	900GB SAS
7420	4x8-core, 2.0GHz	8GB, 16GB	512GB SATA	500GB SATA
7420	4x10-core, 2.40GHz	8GB, 16GB	512GB SATA	500GB SATA

For latest information about supported HDDs and SSDs, see the [Oracle Systems Handbook](#).

You can identify your configuration by looking at the product id on the BUI Maintenance screen or by using the CLI configuration `version show` command. You can also check the physical label on the boot drive.

Refer to <http://oracle.com/zfsstorage> for the most recent component specification.

7420 Front Panel Components

FIGURE 38 7420 Front Panel

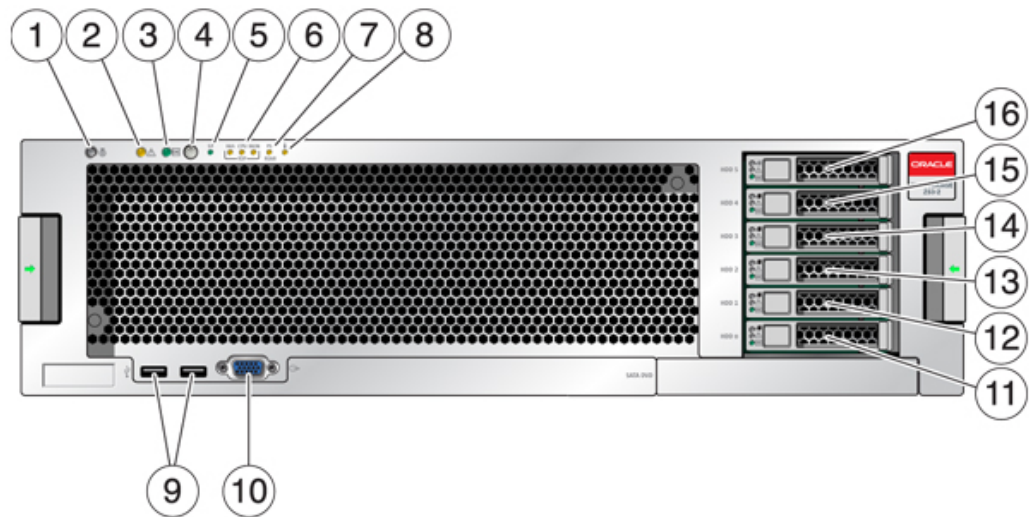

Figure Legend

1 Locator LED and button (white)	2 Service Required LED (amber)	3 Power/OK LED (green)
4 Power button	5 Service Processor (SP) OK LED (green)	6 Fan/CPU/Memory Service Required LED
7 Power Supply (PS) Service Required LED	8 Over Temperature Warning LED	9 USB 2.0 Connectors
10 DB-15 video connector	11 Boot drive 0 (mirrored)	12 Boot drive 1 (mirrored)
13 SSD 2 (optional)	14 SSD 3 (optional)	15 SSD 4 (optional)
16 SSD 5 (optional)		

The 7420 M2 has two SAS-2 system boot drives in slots 0 and 1, configured as a mirrored pair. Up to four SAS-2 read cache SSDs may fill slots 2 through 5, in order. In a 7420 M2 cluster, the number of SSDs installed in each controller can vary.

7420 controllers have two SATA system boot drives in slots 0 and 1, configured as a mirrored pair. Zero, two, three, or four read cache SSDs, may optionally fill slots 2 through 5, in order. In a 7420 cluster, the number of SSDs installed in both controllers must match.

For information about supported HDDs and SSDs, see the [Oracle Systems Handbook](#).

FIGURE 39 SAS-2 and SATA Boot Drive LEDs

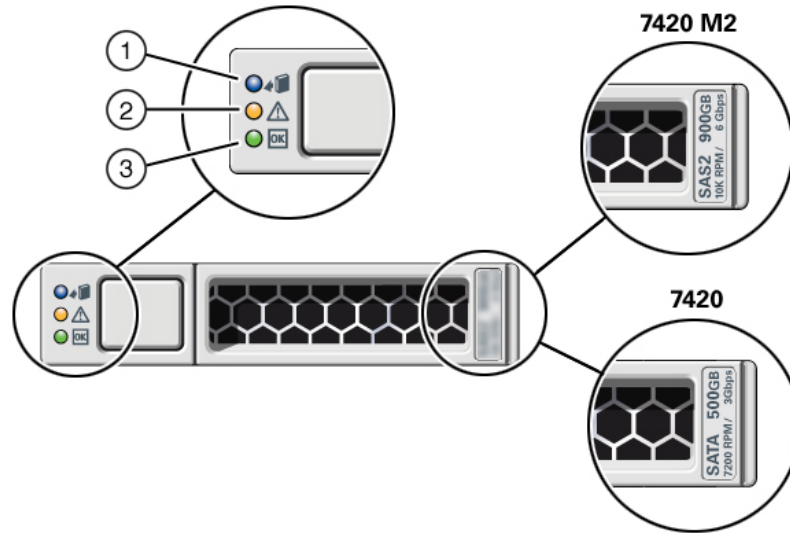

Figure Legend

1 Ready to remove (blue)	2 Service action required (amber)	3 OK/Activity (green)
--------------------------	-----------------------------------	-----------------------

7420 Rear Panel Components

The following graphic shows the rear panel of the controller. Base configuration HBAs are not depicted in this illustration.

For information about PCIe cards, see “7420 PCIe I/O Cards” in [Oracle ZFS Storage Appliance Customer Service Manual](#).

FIGURE 40 7420 Controller Rear Panel

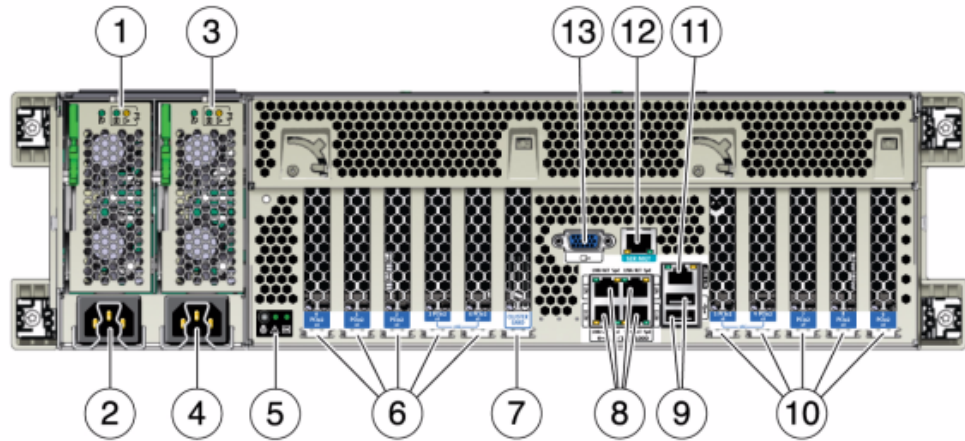

Figure Legend

1 Power supply unit 0 status LEDs OK: green Power Supply Fail: amber AC OK: green	2 Power supply unit 0 AC inlet	3 Power supply unit 1 status LEDs OK: green Power Supply Fail: amber AC OK: green
4 Power supply unit 1 AC inlet	5 System status LEDs Power: green Attention: amber Locate: white	6 PCIe slots 0-4
7 Cluster card slot	8 Network (NET) 10/100/1000 ports: NET 0-NET 3	9 USB 2.0 ports
10 PCIe slots 5-9	11 Network management (NET MGT) 10/100 BASE-T Ethernet port	12 Serial management (SER MGT) port
13 DB-15 video connector		

Overview of 7320 Controller

This section provides an overview of the Oracle ZFS Storage 7320 controller. For installation instructions, refer to [“Installing a 7x20 Controller” on page 179](#). For service instructions, refer to [“Servicing the 7420 or 7320 Controller” in Oracle ZFS Storage Appliance Customer Service Manual](#).

7320 Electrical Specifications

The following list shows the electrical specifications for the 7320 controller.

Note - The power dissipation numbers listed are the maximum rated power numbers for the power supply. The numbers are not a rating of the actual power consumption of the appliance.

Connectors

- Two C13 connectors, which work on 110-220v outlets

Input

- Nominal frequencies: 50/60Hz
- Nominal voltage range: 100-120/200-240 VAC
- Maximum current AC RMS: 9.0 amps Max
- AC operating range: 90-264 VAC

Output

- 3.3 VDC STBY: 3.6A
- +12 VDC: 62.3A

Power dissipation

- Max power consumption: 873 W
- Max heat output: 2977 BTU/hr
- Volt-Ampere rating: 891 VA @ 240 VAC, 0.98P.F.

7320 Base Configurations

The 7320 controller base configuration options are:

- Single or cluster
- 24GB or 96GB RAM
- 2x2.4GHz Quad-Core processors
- One external SAS HBA
- Four 10/100/1000 Ethernet ports

7320 Front Panel Components

The following figure and legend identify the front panel LEDs.

FIGURE 41 7320 Controller Front Panel

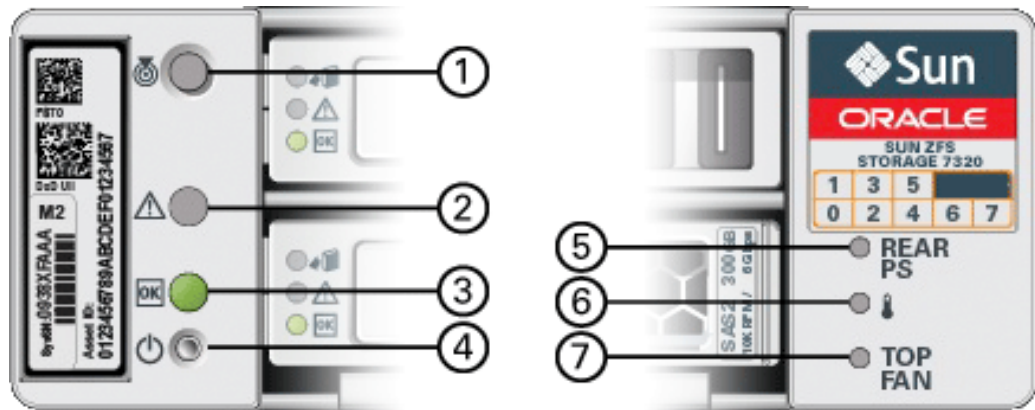

Figure Legend

1 Locate Button/LED	2 Service Required LED (amber)	3 Power/OK LED (green)
4 Power Button	5 Rear Power Supply	6 System Overtemperature LED
7 Top Fan		

The following figure and legend identify the 7320 front panel drive locations. Two mirrored hard disk drives (HDDs) that store the operating system reside in slots 0 and 1. Up to four solid state drives (ReadZilla SSDs), which store the read cache, fill slots 2 through 5, in order. Slots 6 and 7 are empty and must contain drive fillers.

FIGURE 42 7320 Front Panel Drive Locations



Disk Drive Locations				
HDD1	HDD3	HDD5		
HDD0	HDD2	HDD4	HDD6	HDD7

7320 Rear Panel Components

Following is an illustration of the 7320 storage controller rear panel. The Sun 375-3609 belongs in slot 2, cannot be installed in any other slots, and a second is not offered as an option.

For information about PCIe cards, see [“7320 Configuration Options” in Oracle ZFS Storage Appliance Customer Service Manual](#).

FIGURE 43 7320 Controller Rear Panel

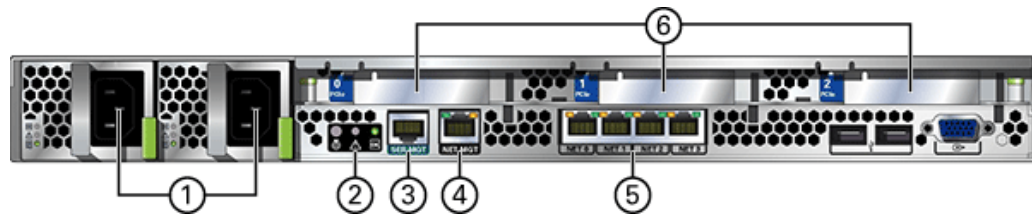

Figure Legend

1 Power supplies	2 SC summary status LEDs	3 Serial management port
4 Network management (NET MGT) 10/100 BASE-T Ethernet port	5 Ethernet ports	6 PCIe slots

The 7320 controller has the following ports:

- **Ethernet Ports** - There are four RJ-45 Gigabit Ethernet ports (NET 0, NET 1, NET 2, NET 3) located on the motherboard that operate at 10/100/1000 Mbit/sec. These network interfaces must be configured before use.
- **Network Management Port** - The network management connector (NET MGT) is an RJ-45 10/100 BASE-T Ethernet port and provides an alternate terminal interface to the SP console.



- **Serial Management Port** - The serial management connector (SERIAL MGT) is an RJ-45 connector and is a terminal connection to the SP console.



Overview of 7120 Controller

This section provides an overview of the Oracle ZFS Storage 7120 controller. For installation instructions, refer to “[Installing a 7x20 Controller](#)” on page 179. For service instructions, refer to the [Oracle ZFS Storage Appliance Customer Service Manual](#).

7120 Physical Specifications

The 7120 controller 2U chassis dimensions are as follows:

Dimension	Measurement	Dimension	Measurement
Height	87.6 mm/3.45 in	Depth	765.25 mm/30.13 in
Width	436.8 mm/17.2 in	Weight	29.54 kg/65 lb

Refer to <https://www.oracle.com/storage/nas/index.html> for the most recent component specification.

7120 Electrical Specifications

The following list shows the electrical specifications for the 7120. Note that the power dissipation numbers listed are the **maximum** rated power numbers for the power supply. The numbers are not a rating of the actual power consumption of the appliance.

Connectors

- Two C13 connectors, which work on 110-220v outlets

Input

- Nominal frequencies: 50/60Hz
- Nominal voltage range: 100-120/200-240 VAC
- Maximum current AC RMS: 13.8A @ 100 VAC
- AC operating range: 90-264 VAC

Output

- 3.3 VDC STBY: 3.0A
- +12 VDC: 86.7A

Power dissipation

- Max power consumption: 1235.3 W
- Max heat output: 4212 BTU/hr
- Volt-Ampere rating: 1261 VA @ 240 VAC, 0.98P.F.

7120 Front Panel Components

The following figure and legend show the front panel and the drive locations. The Logzilla 3.5" SSD belongs in slot 3 and is not supported in controllers configured with the internal Sun Aura flash HBA Logzilla.

FIGURE 44 7120 Controller Front Panel

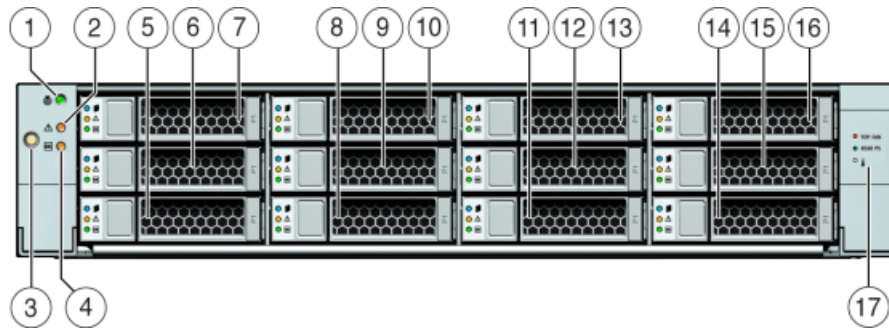

Figure Legend

1 Locator LED/button (white)	2 Service Action Required LED (amber)	3 Power button	4 Power/OK LED (green)
------------------------------	---------------------------------------	----------------	------------------------

Figure Legend			
5 HDD 0	6 HDD 1	7 HDD 2	8 HDD or SSD 3
9 HDD 4	10 HDD 5	11 HDD 6	12 HDD 7
13 HDD 8	14 HDD 9	15 HDD 10	16 HDD 11
17 Drive map			

7120 Rear Panel Components

The following figure and legend show the rear panel.

Note - Optional Sun Dual Port 40Gb/sec 4x Infiniband QDR HCAadapter PCIe cards (375-3606-01) may be located in slots 1, 2, or 3. 375-3606-01 HCA expansion cards are not supported in the 10Gb network configurations. For more information about PCIe cards, see [“7120 PCIe Options”](#) in *Oracle ZFS Storage Appliance Customer Service Manual*.

FIGURE 45 7120 Controller Rear Panel

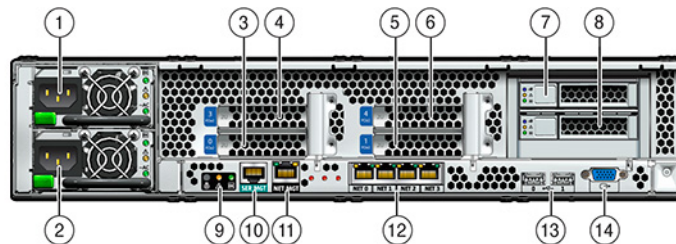

Figure Legend		
1 Power Supply Unit 1	2 Power Supply Unit 0	3 PCIe 0
4 PCIe 3	5 PCIe 1	6 PCIe 4
7 Boot HDD 1	8 Boot HDD 0	9 Rear Panel System Status LEDs
10 Serial Management port	11 Network Management port	12 Gbit Ethernet ports NET 0, 1, 2, 3
13 USB 2.0 ports (0, 1)	14 HD15 Video port	

The 7120 controller has the following ports:

- **Ethernet Ports** - There are four RJ-45 Gigabit Ethernet ports (NET 0, NET 1, NET 2, NET 3) located on the motherboard that operate at 10/100/1000 Mbit/sec. These network interfaces must be configured before use.
- **Network Management Port** - The network management connector (NET MGT) is an RJ-45 port and provides an alternate terminal interface to the SP console.



- **Serial Management Port** - The serial management connector (SER MGT) is an RJ-45 port and provides a terminal connection to the SP console.



Installing Disk Shelves

This section contains installation procedures for DE3-24, DE2-24, and Sun Disk Shelves.

Before beginning installation, review the prerequisites and appropriate hardware overview in [“Installation Prerequisites and Hardware Overviews” on page 13](#). For disk shelf placement within the rack and other considerations, see [“Cabinet Configuration Guidelines” on page 17](#).

Use the following procedures to install disk shelves:

- [“Installing a DE3-24P Disk Shelf” on page 83](#)
- [“Installing a DE3-24C Disk Shelf” on page 87](#)
- [“Installing a DE2-24P Disk Shelf” on page 93](#)
- [“Installing a DE2-24C Disk Shelf” on page 98](#)
- [“Installing a Sun Disk Shelf” on page 103](#)

▼ Installing a DE3-24P Disk Shelf

The Oracle Storage Drive Enclosure DE3-24P requires two rack units (RU), or six rack holes, of vertical space in the cabinet.

- Before You Begin**
- Review [“Prerequisites for Installation” on page 13](#) and [“Overview of Disk Shelves” on page 23](#).
 - To prevent the cabinet from tipping, always load the heaviest equipment, which are disk shelves, starting from the bottom of the cabinet.
 - To best prepare for cabling disk shelves to controllers, now and in the future, mount controllers in the middle of the cabinet.
 - Screws are not provided for installation into a cabinet with M6-sized threaded holes.



Caution - This procedure requires a minimum of two people, or a mechanical lift, because of the weight of the chassis. Attempting this procedure alone could result in equipment damage or personal injury. Do not lift the chassis using the power supply handles.

1. **Starting at the bottom of the cabinet, locate the appropriate rack unit (RU) height.**

2. Unpack the contents of the disk shelf rail kit box, and identify the correct cage nuts for your rack type.

There are two cage nut packets, each containing square or round hole cage nuts. Although a template is also included in the packets, it is not used for the DE3-24P disk shelf.

Note - This procedure shows rail kit installation for a square hole rack. The same steps apply for a round hole rack. Also, screws are not provided for M6-sized threaded rack holes.

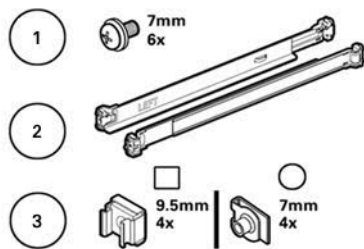

Callout	Description
1	Six 10-32 7 mm screws (two spares)
2	Two adjustable shelf rails
3	Two packets of four 10-32 cage nuts (only one set is required): <ul style="list-style-type: none"> ■ Four 9.5 mm square cage nuts (two spares) ■ Four 7 mm round cage nuts (two spares)

3. Attach the disk shelf rails to the rack, as follows:

- a. Orient the rail so that the stamped label (LEFT or RIGHT) is facing the inside of the rack.
- b. Adjust the rail length to fit the front and rear of the rack [A and B].

Note - Mark which rack rail holes you will be using to ensure the shelf rails are installed evenly.

- c. Press and hold open the clamp lever on each rail end [1], and insert both rail ends into the appropriate rack holes [2].

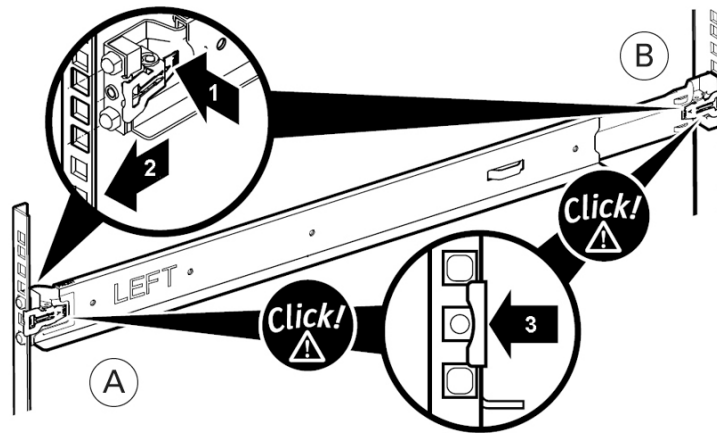

- d. Close the rail clamps over the rails by releasing the clamp lever [3].
You will hear an audible click as the clamps lock in place over the rack rails.
- e. Repeat steps a through d for the second rail.

4. **Install one screw through the rack and into the rear of each rail.**

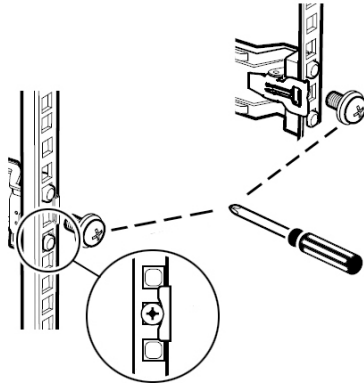

5. **Using a mechanical lift or *two* people, one at each side of the disk shelf, carefully lift and rest the shelf on the bottom ledge of the left and right rails. Do not lift using the power supply handles.**

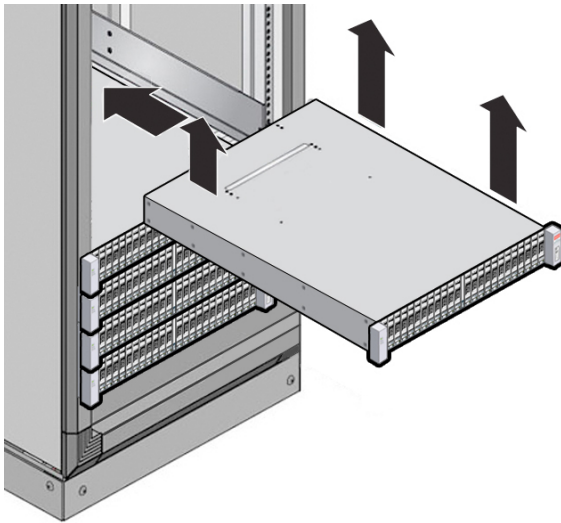

6. **Carefully slide the disk shelf into the cabinet. Ensure that it is fully seated within the rails. If removing the disk shelf to reset it, support it at all times.**

7. Secure the front of the disk shelf using the two captive screws [1 and 2].

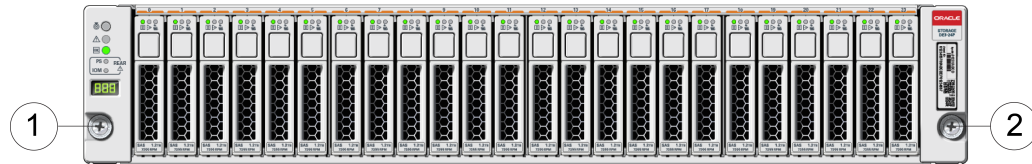

8. If shipping the racked disk shelf, install a screw [1 and 2] into each rear chassis ear [A].

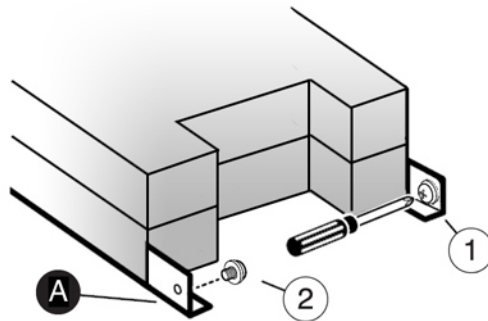

▼ Installing a DE3-24C Disk Shelf

The Oracle Storage Drive Enclosure DE3-24C requires four rack units (RU), or twelve rack holes, of vertical space in the cabinet.

- Before You Begin**
- Review [“Prerequisites for Installation” on page 13](#) and [“Overview of Disk Shelves” on page 23](#).
 - To prevent the cabinet from tipping, always load the heaviest equipment, which are disk shelves, starting from the bottom of the cabinet.
 - To best prepare for cabling disk shelves to controllers, now and in the future, mount controllers in the middle of the cabinet.
 - Screws are not provided for installation into a cabinet with M6-sized threaded holes.



Caution - This procedure requires a minimum of three people, or a mechanical lift, because of the weight of the chassis. Attempting this procedure alone could result in equipment damage or personal injury. Do not lift the chassis using the power supply handles.

1. **Starting at the bottom of the cabinet, locate the appropriate rack unit (RU) height.**
2. **Unpack the contents of the disk shelf rail kit box, and identify the correct cage nuts for your rack type.**

There are two cage nut packets, each containing square or round hole cage nuts. Each packet also contains a template for positioning the cage nuts.

Note - This procedure shows rail kit installation for a square hole rack. The same steps apply for a round hole rack. Also, screws are not provided for M6-sized threaded rack holes.



Callout	Description
1	Six 10-32 7 mm captive screws (two spares)
2	Two adjustable shelf rails
3	Two packets of four 10-32 cage nuts (only one set is required): <ul style="list-style-type: none"> ■ Four 9.5 mm square cage nuts (two spares) ■ Four 7 mm round cage nuts (two spares)

3. **Attach the disk shelf rails to the rack, as follows:**
 - a. **Orient the rail so that the stamped label (LEFT or RIGHT) is facing the inside of the rack.**
 - b. **Adjust the rail length to fit the front and rear of the rack [A and B].**

Note - Mark which rack rail holes you will be using to ensure the shelf rails are installed evenly.

- c. Press and hold open the clamp lever on each rail end [1], and insert both rail ends into the appropriate rack holes [2].

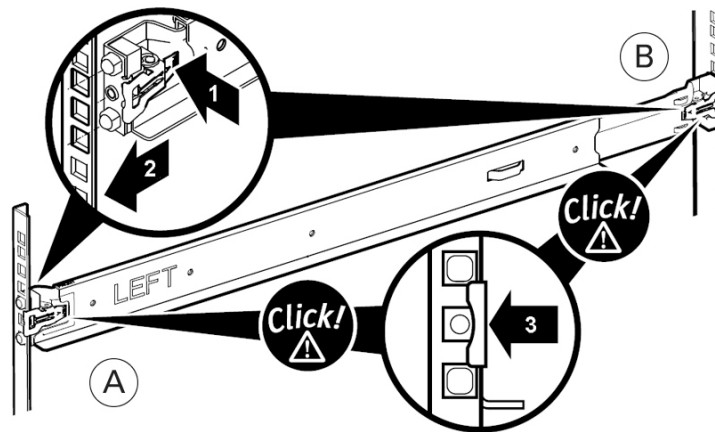

- d. Close the rail clamps over the rails by releasing the clamp lever [3].

You will hear an audible click as the clamps lock in place over the rack rails.

- e. Repeat steps a through d for the second rail.

4. Install one screw through the rack and into the rear of each rail.

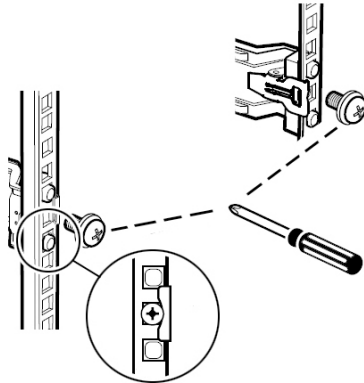

5. Install the front cage nuts.



Caution - A mounted disk shelf is unstable if the front cage nuts are not installed. Always install the cage nuts before mounting the disk shelf.

- a. Use the template to determine cage nut placement [1].

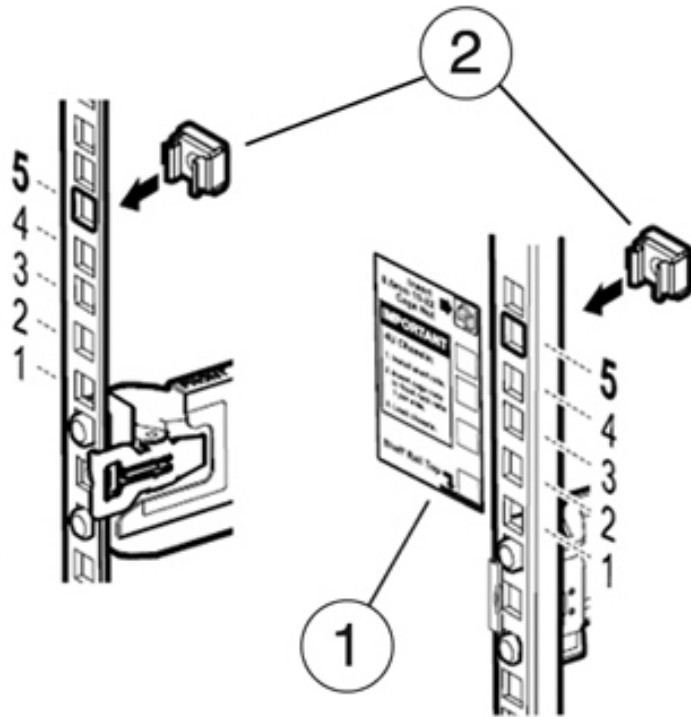

- b. Insert one cage nut into the appropriate hole in each rack rail [2].

- Using a mechanical lift or *three* people, one at each side of the disk shelf and one in front, carefully lift and rest the disk shelf on the bottom ledge of the left and right rails. Do not lift using the power supply handles.

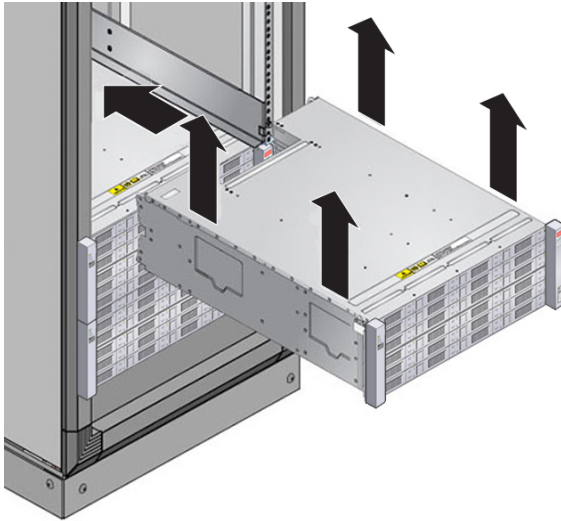

- Carefully slide the disk shelf into the cabinet. Ensure that it is fully seated within the rails. If removing the disk shelf to reset it, support it at all times.
- Secure the front of the disk shelf using the four captive screws [1 - 4].



9. If shipping the racked disk shelf, install a screw [1 and 2] into each rear chassis ear [A].

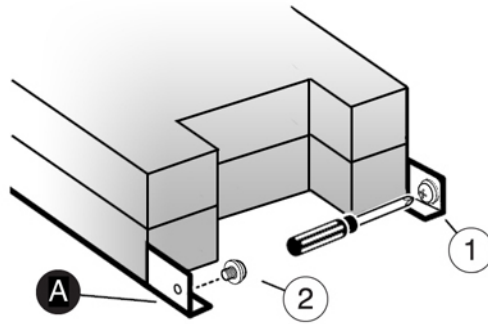

▼ Installing a DE2-24P Disk Shelf

Use the following procedure to install an Oracle Storage Drive Enclosure DE2-24P, which requires two standard mounting rack units (2RU), or six rack holes, of vertical space in the cabinet.

- Before You Begin**
- Review [“Prerequisites for Installation”](#) on page 13 and [“Overview of Disk Shelves”](#) on page 23.
 - To prevent the cabinet from tipping, always load the heaviest equipment, which are disk shelves, starting from the bottom of the cabinet.
 - To best prepare for cabling disk shelves to controllers, now and in the future, mount controllers in the middle of the cabinet.
 - Screws are not provided for installation into a cabinet with M6-sized threaded holes.



Caution - This procedure requires a minimum of two people, or a mechanical lift, because of the weight of the chassis. Attempting this procedure alone could result in equipment damage or personal injury. Do not lift the chassis using the power supply handles.

1. **Extend all anti-tilt and stabilization devices from the bottom of the rack.**
2. **Locate the appropriate rack unit (RU) height, which is six rack holes, starting from the bottom on the cabinet. If your rack is an unthreaded universal 19-inch, Sun Rack II, or Oracle Rack Cabinet 1242 cabinet:**

- a. **Position the front rail location pegs fully inside the appropriate holes in the front of the rack.**

The rail flange must be inside of the cabinet flange, and the rail label facing the inside of the cabinet.

- b. **Insert and tighten one screw through the front of the rack and into the top hole in the rails.**

- c. **Adjust the rail lengths to fit, and position the rear rail location pegs in the corresponding rear rack holes.**

- d. Insert and tighten one screw through the back of the rack and into the back of the rails.

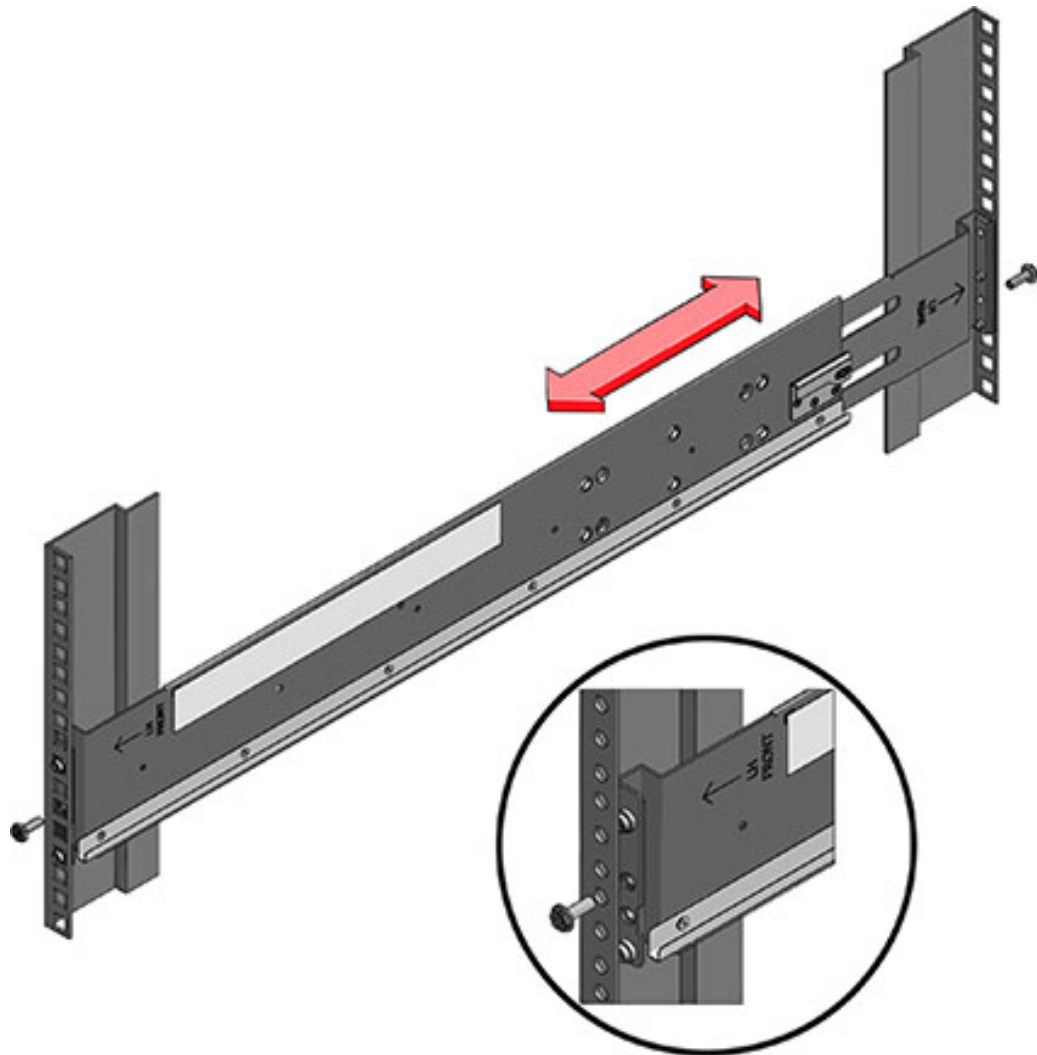

3. If your rack is a threaded universal 19-inch cabinet:

- a. Use the T20 Torx driver to remove the rail location pegs from the front and rear of the rails.
- b. Use the supplied wrench to insert two pins into each end of the rails, in the same location where the location pegs were removed.
- c. Position the front of the rails inside the cabinet, with the rail flange inside of the cabinet flange, and the rail label facing the inside of the cabinet.
The pins should be fully located within the rack holes.
- d. Insert and tighten one screw through the front of the rack and into the top hole in the rails.
- e. Adjust the rail lengths to fit, and locate the rear pins inside the corresponding rear rack holes.
- f. Insert and tighten one screw through the back of the rack and into the back of the rails.

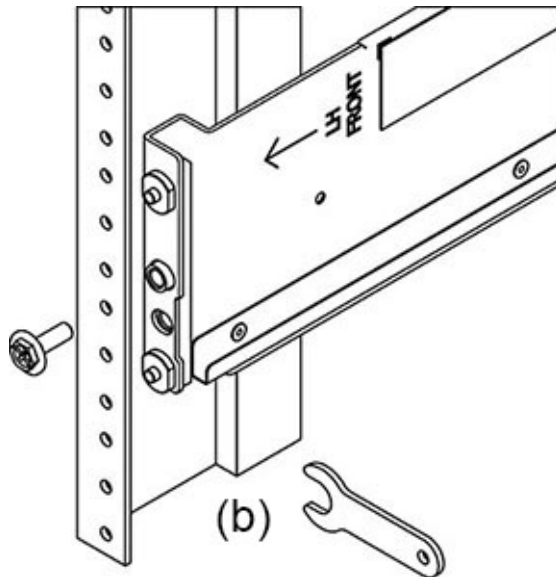

4. Using a mechanical lift or *two* people, one at each side of the disk shelf, carefully lift and rest the shelf on the bottom ledge of the left and right rails. Do not lift using the power supply with fan module handles.

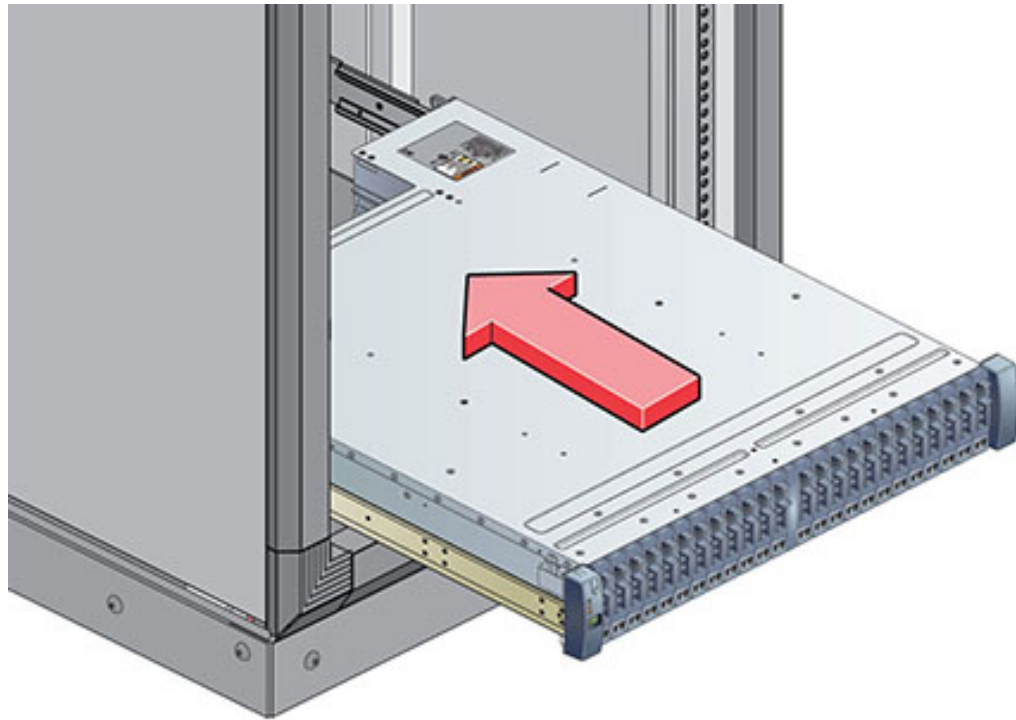

5. Carefully slide the shelf into the rails until it is fully seated within the cabinet. The spotter, using a flashlight, should ensure that the shelf is fully seated within the rails. If removing the shelf to reseal it, support it at all times.

6. **Install one long patchlock screw per rail to secure the rear of the shelf to the rear of the rack. If the screw cannot be inserted, the shelf might not be fully seated within the rails.**

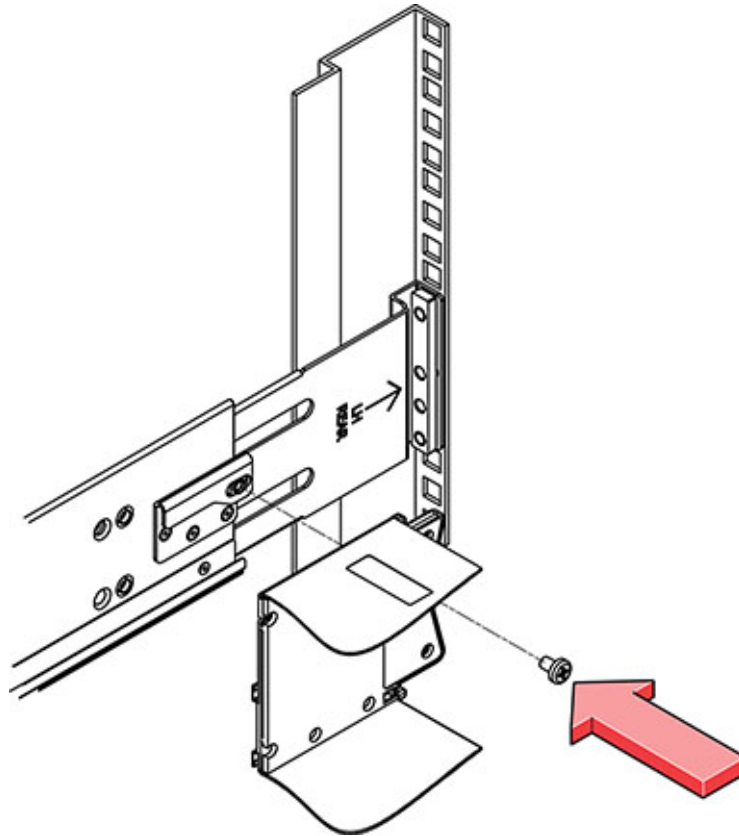

7. **Remove the front side caps, install one screw into each front side, and replace the caps.**

▼ Installing a DE2-24C Disk Shelf

Use the following procedure to install an Oracle Storage Drive Enclosure DE2-24C, which requires four standard mounting rack units (4RU), or twelve rack holes, of vertical space in the cabinet.

- Before You Begin**
- Review [“Prerequisites for Installation” on page 13](#) and [“Overview of Disk Shelves” on page 23](#).
 - To prevent the cabinet from tipping, always load the heaviest equipment, which are disk shelves, starting from the bottom of the cabinet.
 - To best prepare for cabling disk shelves to controllers, now and in the future, mount controllers in the middle of the cabinet.
 - Screws are not provided for installation into a cabinet with M6-sized threaded holes.



Caution - This procedure requires a minimum of three people, or a mechanical lift, because of the weight of the chassis. Attempting this procedure alone could result in equipment damage or personal injury. Do not lift the chassis using the power supply handles.

1. **Extend all anti-tilt and stabilization devices from the bottom of the cabinet.**
2. **Locate the appropriate rack unit (RU) height, which is eight rack holes, starting from the bottom on the cabinet. If using an unthreaded universal 19-inch, Sun Rack II, or Oracle Rack Cabinet 1242 cabinet, snap one supplied cage nut into the appropriate rack holes.**

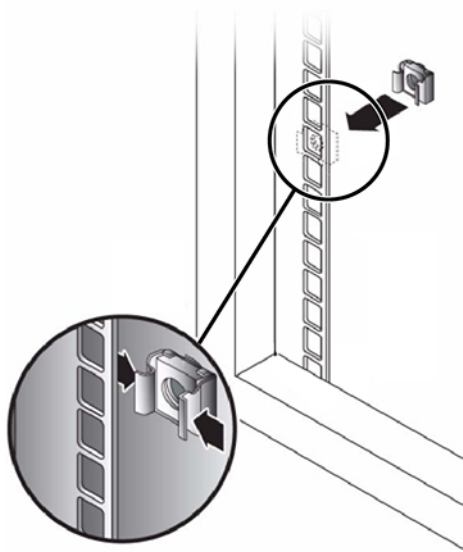

3. **Prepare the screws in each rail end:**

- **Square-hole unthreaded cabinet** - No preparation.
 - **Round-hole unthreaded cabinet** - Remove the screws from each rail end and discard. Locate the screws for round-hole cabinets and place aside.
 - **Threaded cabinet** - Remove screws and replace them in the opposite direction (from the inside of the rail flange) so they act as location pins. Also remove the clip nut from each front rail end and discard.
4. **Position the front of the rails inside the cabinet, with the rail flange inside of the cabinet flange, and the rail label facing the inside of the cabinet.**
- **Square-hole unthreaded cabinet** - The screw heads fit inside the rack holes.
 - **Round-hole unthreaded cabinet** - Install two screws through the rack and into the front of each rail. Do *not* install into the cage nut in the rack, or the clip nut on the rail.
 - **Threaded cabinet** - The location pins fit inside the rack holes.
5. **Adjust the rail lengths to fit.**

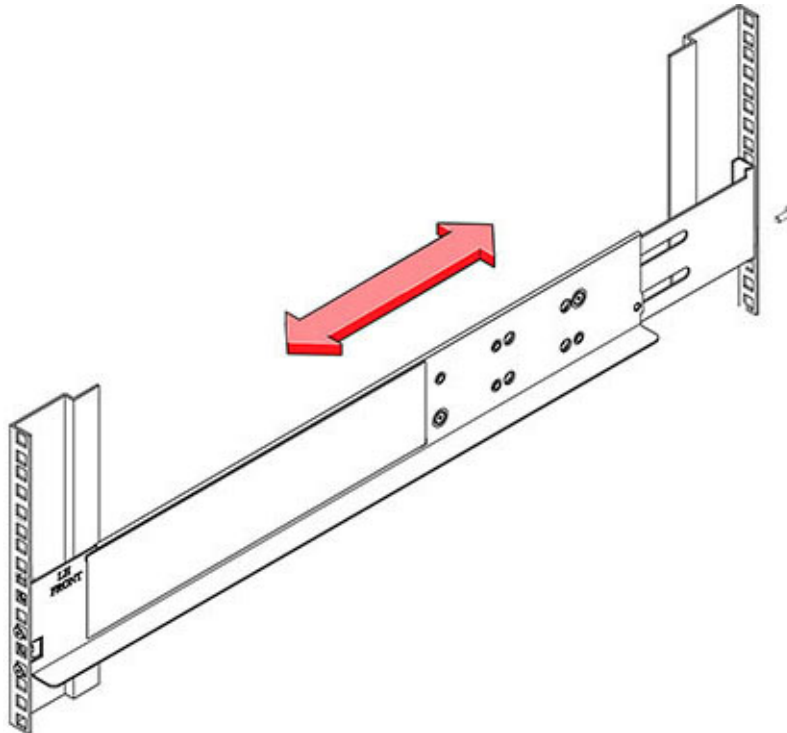

6. Install one screw through the rack and into the rear of each rail.
7. Tighten the two locking screws in the rails.

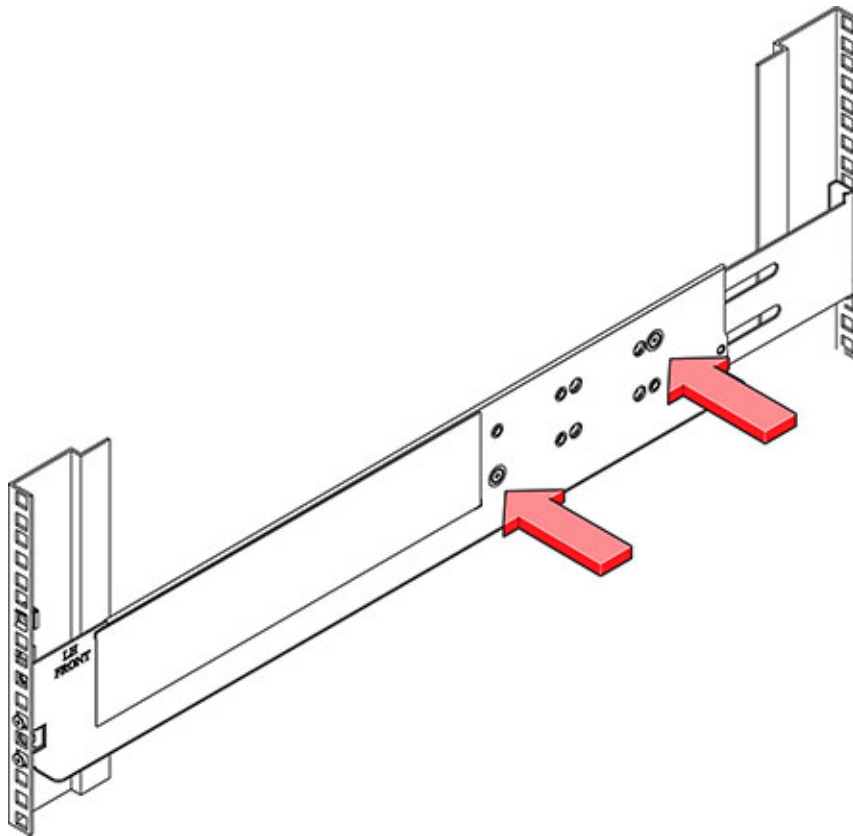

8. Using a mechanical lift or *two* people, one at each side of the disk shelf, carefully lift and rest the shelf on the bottom ledge of the left and right rails. Do not lift using the power supply handles.

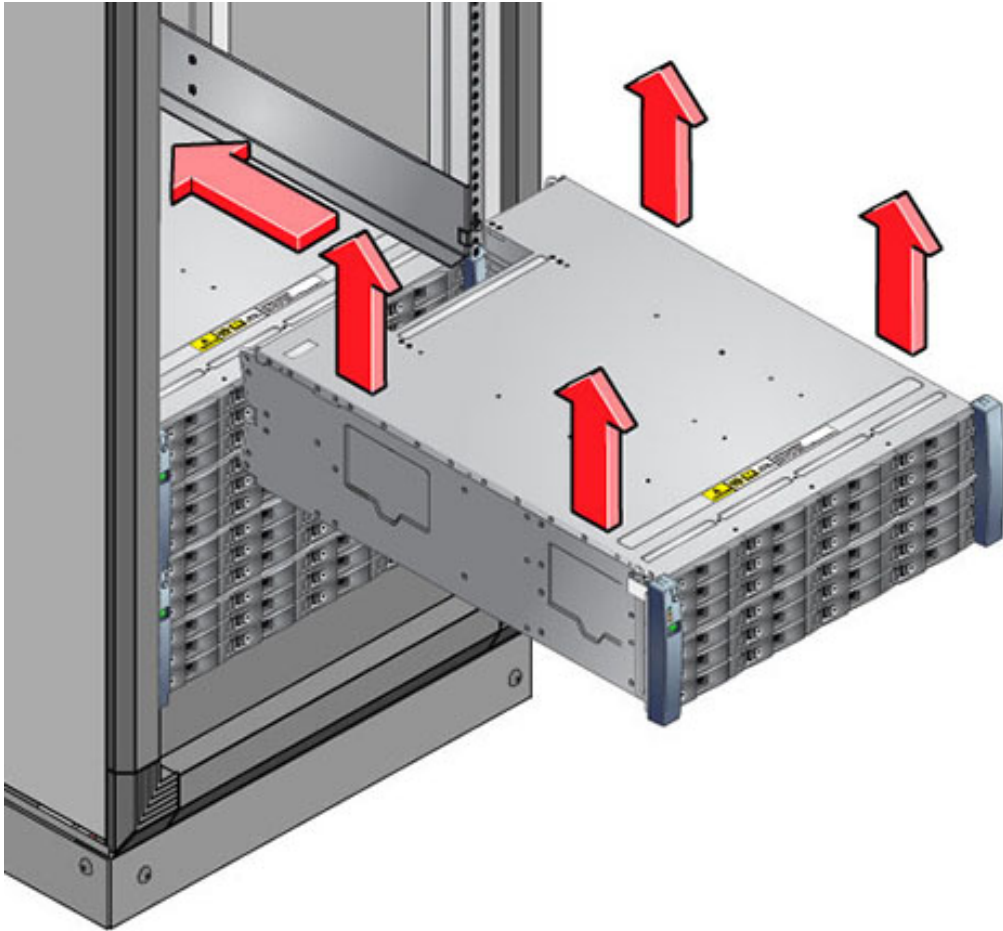

9. Carefully slide the shelf into the cabinet. Ensure that the shelf is fully seated within the rails. If removing the shelf to reseal it, support it at all times.
10. Remove the front side caps, install two screws into each front side, and replace the caps.

11. Install one long patchlock screw per rail to secure the rear of the shelf to the rear of the rack.

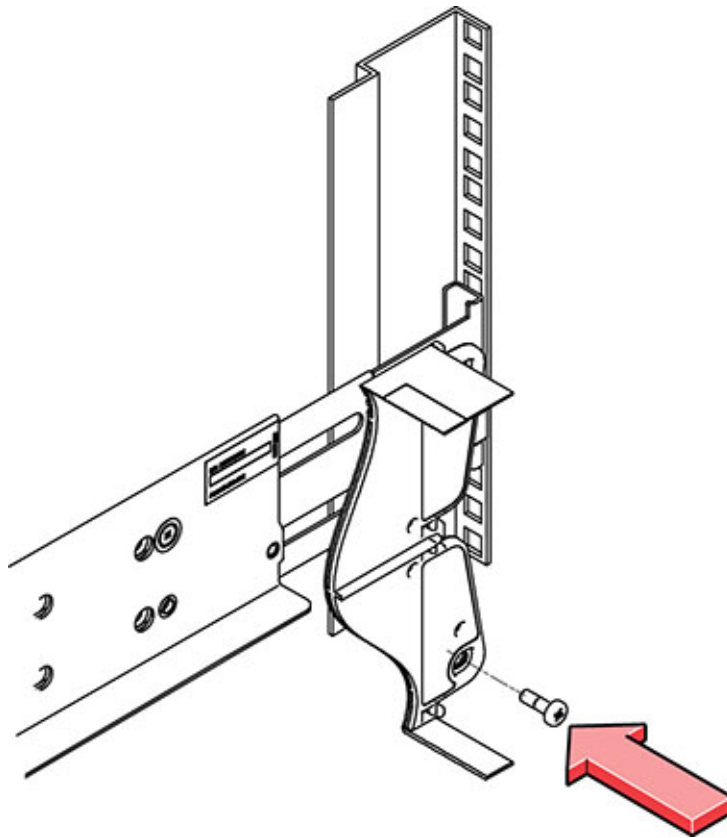

▼ Installing a Sun Disk Shelf

Use the following procedure to install a Sun Disk Shelf.

Starting at the bottom of the cabinet, locate the appropriate rack unit (RU) height. Install Disk Shelves below controllers to prevent rack from tipping. The Sun Disk Shelf requires four standard mounting units (4RU) of vertical space in the cabinet.



Caution - This procedure requires a minimum of two people, or a mechanical lift, because of the weight of the chassis. Attempting this procedure alone could result in equipment damage or personal injury. Always load the heaviest equipment (disk shelves) at the bottom of the rack.

Before You Begin Extend all anti-tilt and stabilization devices from the bottom of the rack.

1. **If you are using a universal 19-inch or Sun Rack II cabinet, snap an M6 square cage nut into the 4U location where you will be installing the system. Install in the top and bottom holes.**

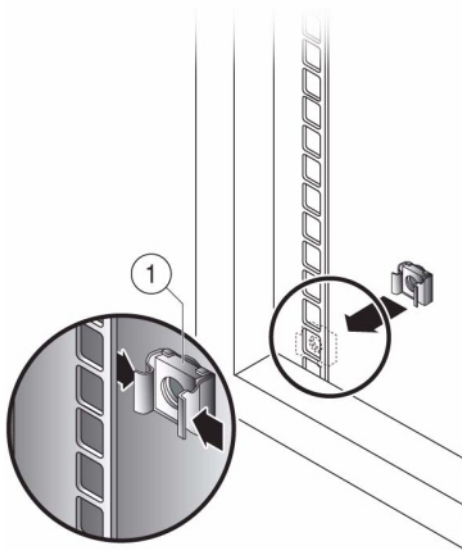

2. **Install appropriate rail plates in four locations on the rack (2 front and 2 back) by aligning the two pins on the rail plate with holes on the cabinet rails.**

3. **Insert M6 screws in the top and bottom holes of each rail plate and tighten (8 total places).**

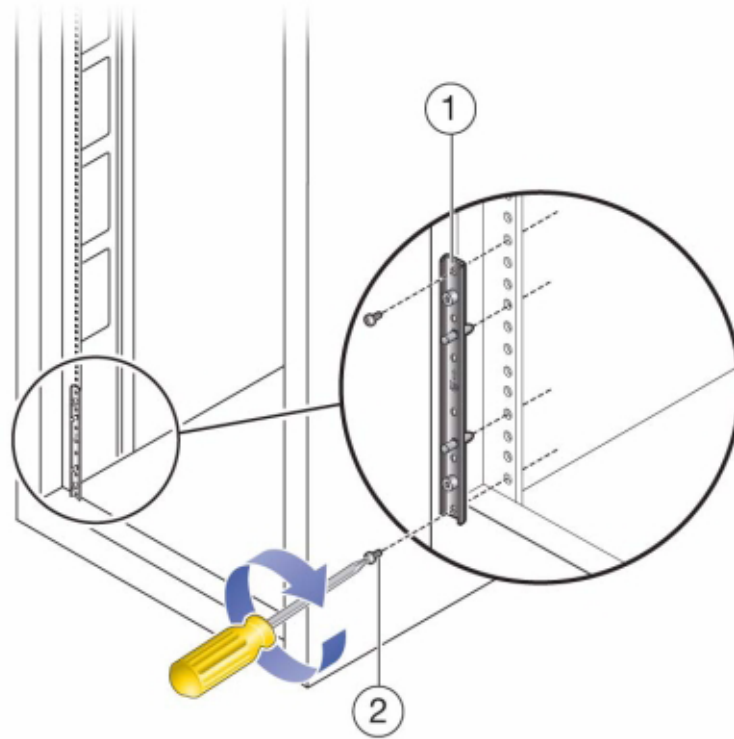

4. **Install each rail by first aligning the front pins of the rack adapter plates with corresponding holes in the front of the rail, then adjust the rail to fit the rack and insert the pins from the rear rack adapter plates into the corresponding holes of the rail.**

5. Install four 8-32 screws into the four remaining front and rear holes of each rack rail (16 total).

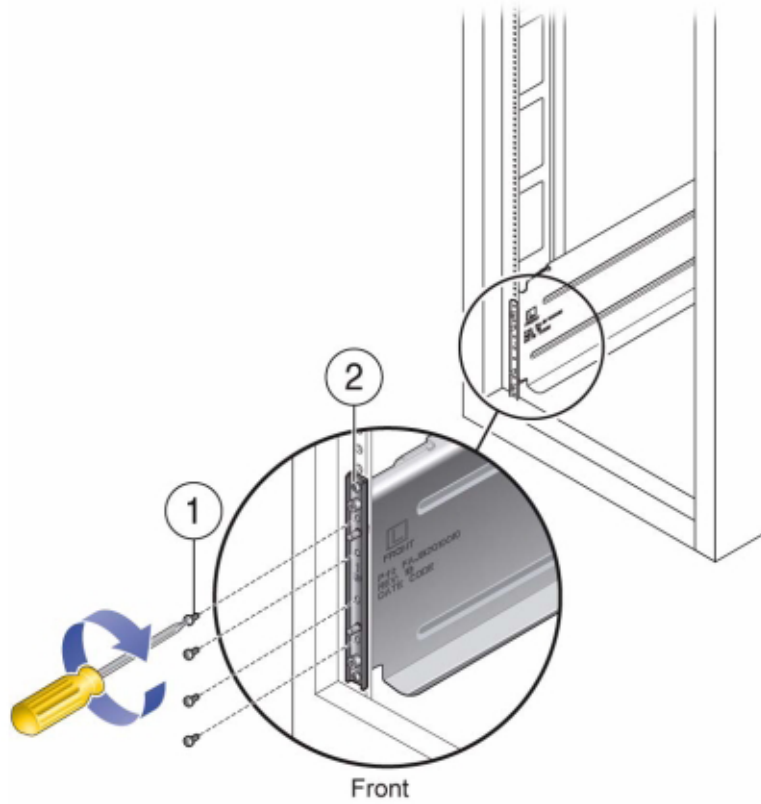

6. Using a mechanical lift or two people, one at each side of the shelf or controller, carefully lift and rest the shelf on the bottom ledge of the left and right rails. The following graphic illustrates the chassis insertion.



7. Carefully slide the shelf into the cabinet until the front flanges of the shelf touch the vertical face of the rack.
8. Tighten the captive screws on each side of the front of the shelf to secure the shelf to the rack.
9. At the back of the disk shelf, slide a system locking clip onto each lower corner of the chassis.

Installing a ZS7-2 Controller

This section contains installation procedures for the ZS7-2 controller.

Before beginning installation, see [“Installation Prerequisites and Hardware Overviews”](#) on page 13.

Use the following procedures to install a ZS7-2 controller:

- [“Installing the Slide Rails onto a ZS7-2”](#) on page 109
- [“Installing the Slide Rails into the Rack for a ZS7-2”](#) on page 110
- [“Installing a ZS7-2 onto the Rack Slide Rails”](#) on page 112
- [“Installing a ZS7-2 Cable Management Arm”](#) on page 114
- [“Verifying Operation of ZS7-2 Slide-Rails and CMA”](#) on page 121

▼ Installing the Slide Rails onto a ZS7-2

Use the following procedure to install the slide rails onto a ZS7-2 controller.

Note - The slide rails can be used with either 9.5-mm square or M6 round mounting hole racks.

1. **Position a mounting bracket against the chassis so that the slide-rail lock is at the front of the chassis, and the five keyhole openings on the mounting bracket are aligned with the five locating pins on the side of the chassis.**

Note - The mounting brackets are identical and can be installed on either side of the chassis.

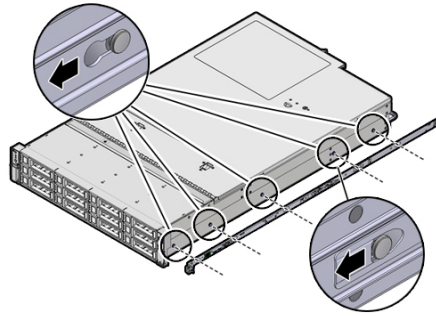

2. **With the heads of the five chassis locating pins protruding through the five keyhole openings in the mounting bracket, pull the mounting bracket toward the front of the chassis until the mounting bracket clip locks into place with an audible click.**
3. **Verify that the rear locating pin has engaged the mounting bracket clip.**
4. **To install the other mounting bracket on the other side of the chassis, repeat Steps 1 through 3.**

▼ Installing the Slide Rails into the Rack for a ZS7-2

Use the following procedure to install the slide rails into the rack for a ZS7-2 controller.

If you plan to move the rack after the controller is installed, use mounting screws and cage nuts to secure the slide-rail assembly. Refer to *Rail Rackmount Kit Overview and Information* card for instructions on inserting these cage nuts. This card is included with the rack kit.

1. **Position a slide-rail assembly in your rack so that the slide-rail assembly front bracket is on the outside of the front rack post and the slide-rail assembly rear bracket is on the inside of the rear rack post.**
2. **Align the slide-rail assembly mounting pins with the front and rear rack post mounting holes. Then lock the assembly into place by pushing the assembly**

toward the rear of the rack until the mounting pins engage the rack with an audible click.

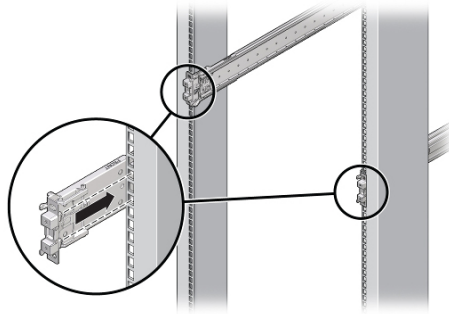

Note - The slide rails can be used with either 9.5-mm square or M6 round mounting hole racks.

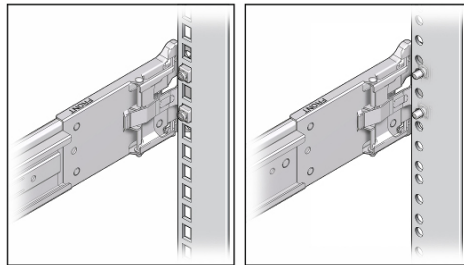

3. **(Optional)** If installing the assembly with cage nuts and mounting screws, insert the cage nuts into the front and rear rack posts in the desired positions. Then

insert the mounting screws through the front and rear slide-rail brackets and rack posts.

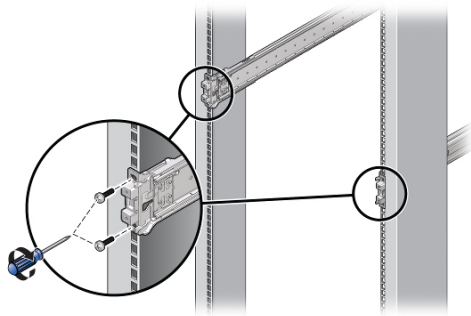

4. Repeat Step 1 to Step 3 for the other slide-rail assembly.

▼ Installing a ZS7-2 onto the Rack Slide Rails

Use the following procedure to install a ZS7-2 controller onto the rack slide rails.



Caution - This procedure requires a minimum of two people, or a mechanical lift, because of the weight of the chassis. Attempting this procedure alone could result in equipment damage or personal injury. Always load the heaviest equipment (disk shelves) at the bottom of the rack.

1. If your rack includes an anti-tip foot, extend it from the bottom of the rack.

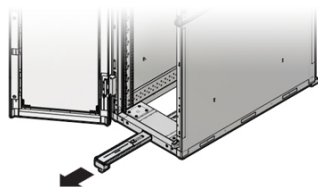

2. Lower the rack stabilization feet if you have not already done so.
3. Push the slide rails into the slide-rail assemblies in the rack as far as possible.

4. **Raise the chassis so that the back ends of the mounting brackets are aligned with the slide rail (1) and insert the chassis into the slide rails, pushing the chassis slowly, until the mounting brackets meet the slide-rail stops (approximately 12 inches, or 30 cm).**



Caution - When inserting the controller into the slide rail, ensure that both the top and bottom mounting lips of the mounting brackets are inserted into the slide rail. The controller should slide forward and backward easily if correctly installed. If the unit does not slide easily, ensure that each mounting lip is inserted properly. If the mounting brackets are not inserted properly, the unit may fall when removing it from the rack, causing equipment damage and possibly personal injury.

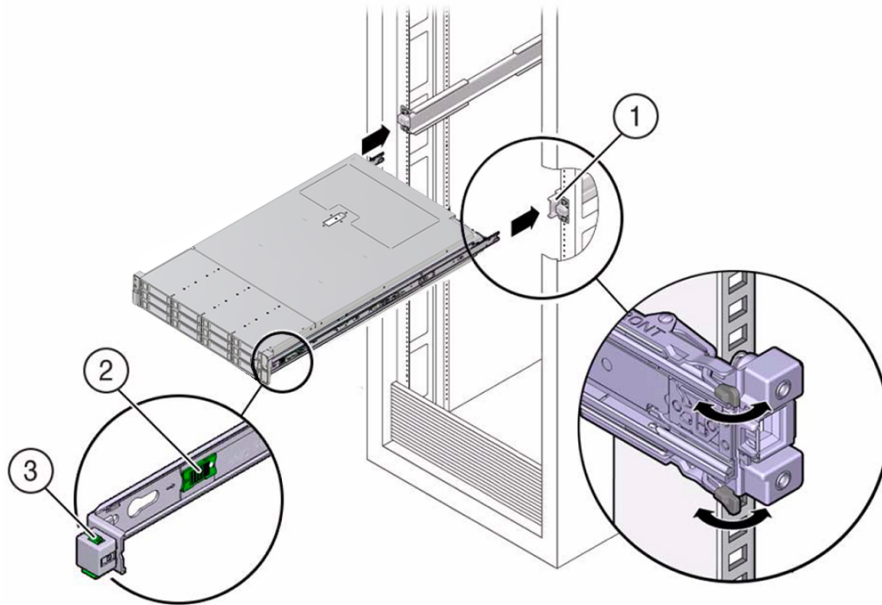

5. **Simultaneously push and hold the green slide-rail release buttons on each mounting bracket (2) while you push the chassis into the rack. Continue pushing**

until the slide-rail locks (on the front of the mounting brackets) engage the slide-rail assemblies (3).

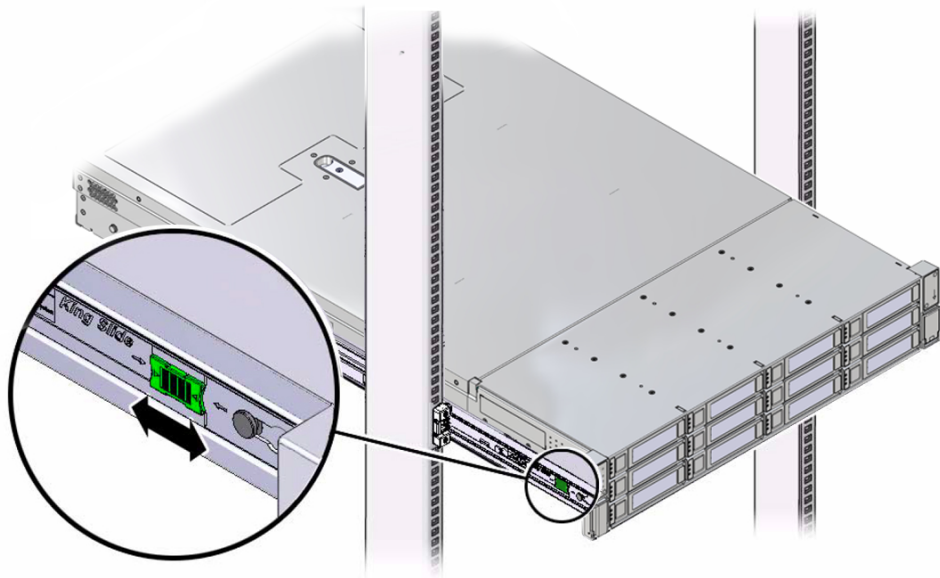

Caution - Verify that the controller is securely mounted in the rack and that the slide-rail locks are engaged with the mounting brackets before continuing, or equipment damage or possibly injury could occur.

▼ Installing a ZS7-2 Cable Management Arm

Use the following procedure to install the cable management arm (CMA) for a ZS7-2 controller.

The CMA is an optional assembly that you can use to route the controller cables in the rack. This procedure is completed from the back of the rack.

Before You Begin To prepare for installing the optional cable management arm (CMA), follow these guidelines:

- Route cluster cables, long-term host cables (including InfiniBand, Fibre Channel, and Ethernet cables) and up to 16 disk shelf SAS cables through the CMA.

- Do not route short SAS daisy chain cables through the CMA. Do not route an excess of cables such that the CMA clamps bow or appear structurally unfit to support the weight.
- If using two clustered controllers mounted in the middle of the rack with disk shelves located above and below them, you can divide the disk shelf SAS cables between the two CMAs so they properly route to the upper and lower disk shelves.
- If later removing the CMA, be sure to support it as you remove the connectors.

1. Unpack the CMA and identify its components.

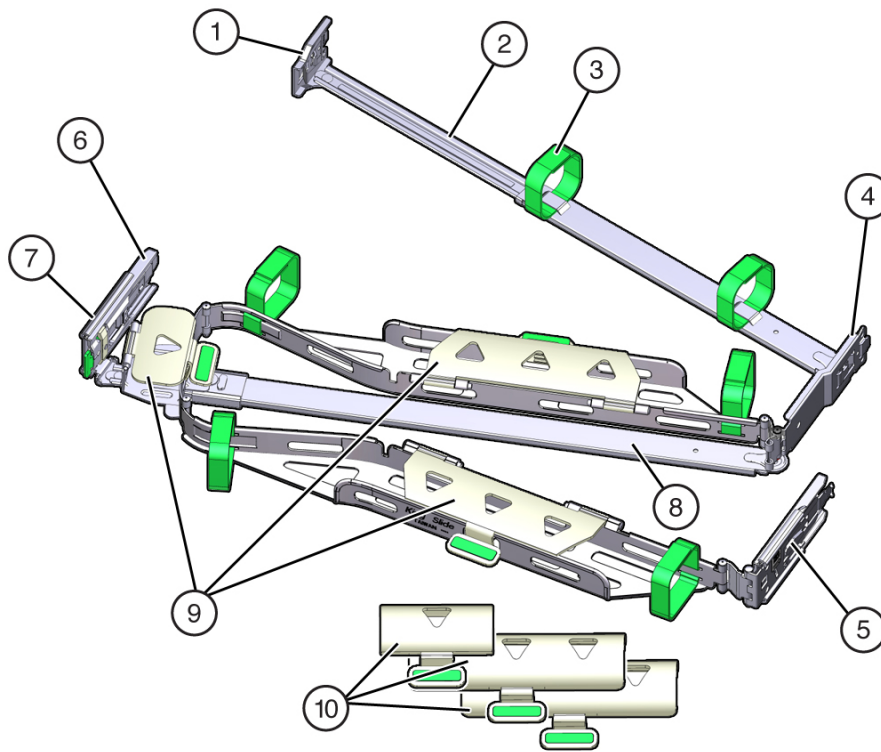

Callout	Description
1	Connector A
2	Front slide bar
3	Velcro straps (6)
4	Connector B

Callout	Description
5	Connector C
6	Connector D
7	Slide-rail latching bracket (used with connector D)
8	Back slide bar
9	Controller flat cable covers
10	Controller round cable covers

2. **Ensure that you install the flat cable covers for your controller on the CMA.**
3. **Ensure that the six Velcro straps are threaded into the CMA.**

Note - Ensure that the two Velcro straps located on the front slide bar are threaded through the opening in the top of the slide bar, as shown in the illustration in Step 1. This prevents the Velcro straps from interfering with the expansion and contraction of the slide bar when the controller is extended out of the rack and returned to the rack.

4. **To make it easier to install the CMA, extend the controller approximately 13 cm (5 inches) out of the front of the rack.**
5. **Take the CMA to the back of the equipment rack, and ensure that you have adequate room to work at the back of the server.**

Note - References to left or right in this procedure assume that you are facing the back of the equipment rack.

Note - Throughout this installation procedure, support the CMA and do not allow it to hang under its own weight until it is secured at all four attachment points.

6. **To install CMA connector A into the left slide-rail:**
 - a. **Insert CMA connector A into the front slot on the left slide-rail until it locks into place with an audible click [frames 1 and 2].**

The connector A tab (callout 1) goes into the slide-rail front slot (callout 2).

- b. Gently tug on the left side of the front slide bar to verify that connector A is properly seated.

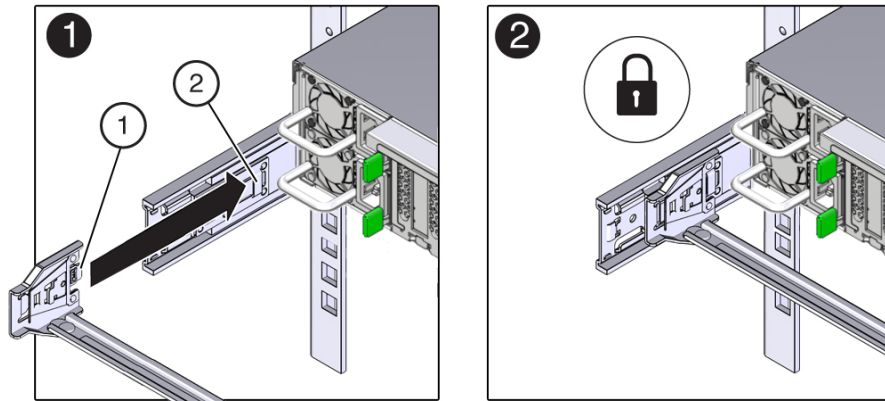

Callout	Description
1	Connector A tab
2	Left slide-rail front slot

7. To install CMA connector B into the right slide-rail:
- a. Insert CMA connector B into the front slot on the right slide-rail until it locks into place with an audible click [frames 1 and 2].
- The connector B tab (callout 1) goes into the slide-rail front slot (callout 2).

- b. Gently tug on the right side of the front slide bar to verify that connector B is properly seated.

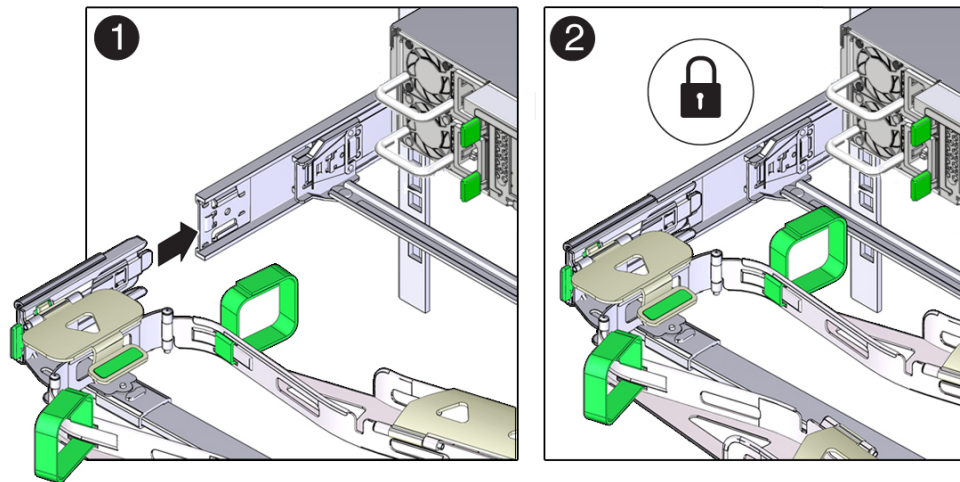

Callout	Description
1	Connector B tab
2	Right slide-rail front slot

8. To install CMA connector C into the right slide-rail:

- a. Align connector C with the slide-rail so that the locking spring (callout 1) is positioned inside (controller side) of the right slide-rail [frame 1].

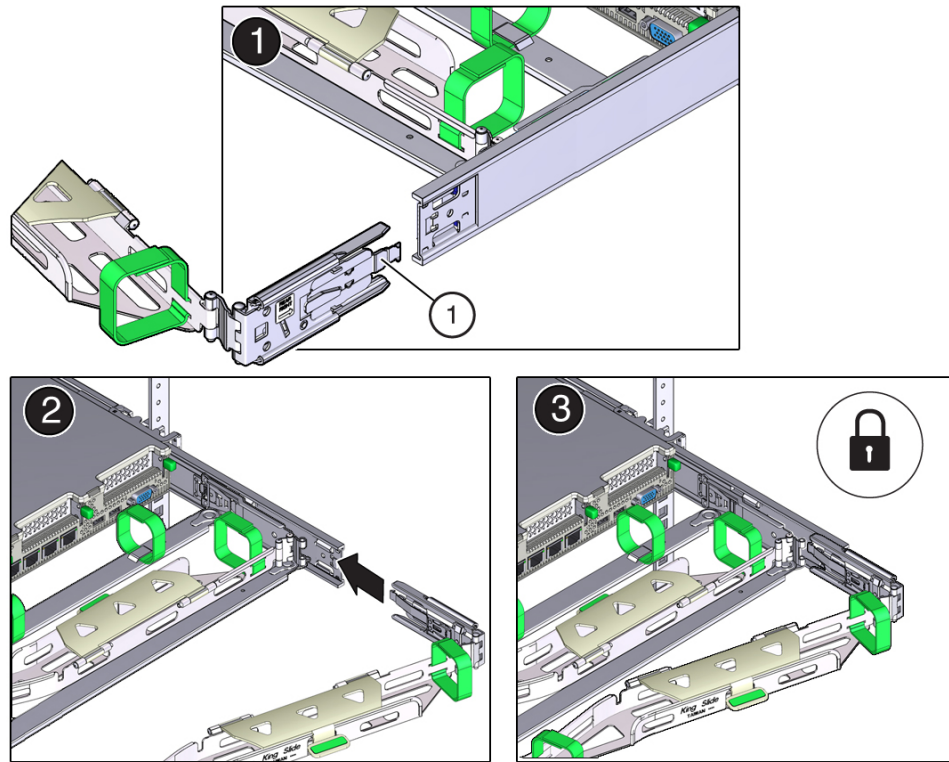

Callout	Description
1	Connector C locking spring

- b. Insert connector C into the right slide-rail until it locks into place with an audible click [frames 2 and 3].
- c. Gently tug on the right side of the CMA back slide bar to verify that connector C is properly seated.

9. To prepare CMA connector D for installation, remove the tape that secures the slide-rail latching bracket to connector D, and ensure that the latching bracket is properly aligned with connector D [frames 1 and 2].

Note - The CMA is shipped with the slide-rail latching bracket taped to connector D. You must remove the tape before you install this connector.

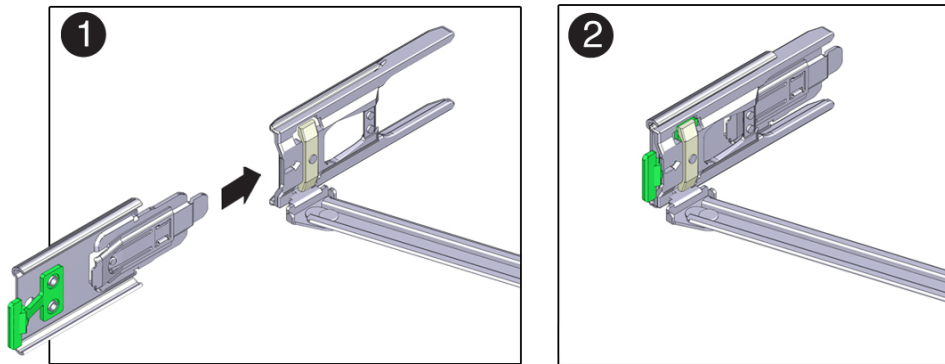

10. To install CMA connector D into the left slide-rail:
 - a. While holding the slide-rail latching bracket in place, insert connector D and its associated slide-rail latching bracket into the left slide-rail until connector D locks into place with an audible click [frames 1 and 2].

Note - When inserting connector D into the slide-rail, the preferred and easier method is to install connector D and the latching bracket as one assembly into the slide-rail.

- b. Gently tug on the left side of the CMA back slide bar to verify that connector D is properly seated.

Note - The slide-rail latching bracket has a green release tab. This tab is used to release and remove the latching bracket so that you can remove connector D.

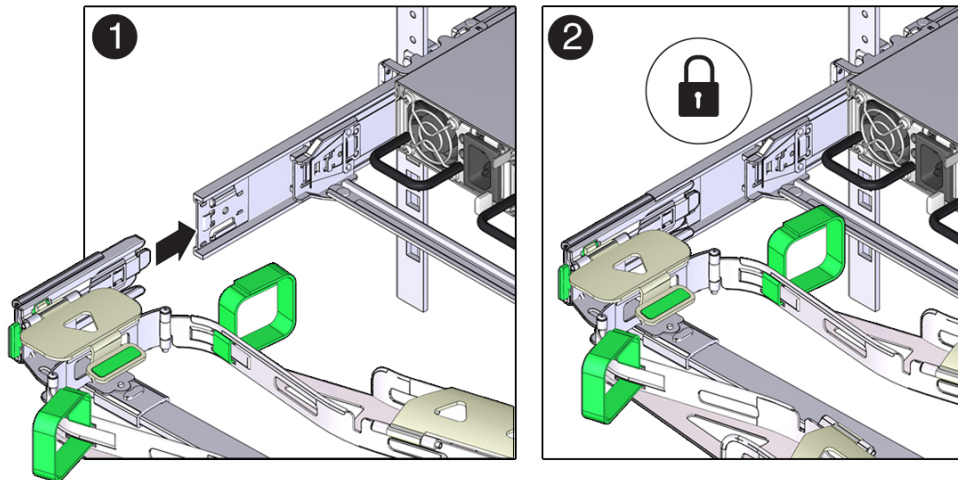

11. Gently tug on the four CMA connection points to ensure that the CMA connectors are fully seated before you allow the CMA to hang by its own weight.
12. Install and route cables to the controller, as required.

▼ Verifying Operation of ZS7-2 Slide-Rails and CMA

Use the following procedure to verify the operation of the CMA and slide rails for a ZS7-2 controller.

Before You Begin Ensure all rack anti-tilt devices are extended to prevent the rack from tipping forward when the storage controller is extended from the rack.

1. Slowly pull the storage controller out of the rack until the slide-rails reach their stops.
2. Inspect the attached cables for any binding or kinks.
3. Verify that the CMA extends fully with the slide-rails.

4. **Push the storage controller back into the rack and verify that the CMA retracts without binding.**
5. **Adjust the cable straps and the CMA, as required.**

Installing a ZS5-4 Controller

This section contains installation procedures for the ZS5-4 controller.

Before beginning installation, see [“Installation Prerequisites and Hardware Overviews”](#) on page 13.

Use the following procedures to install a ZS5-4 controller:

- [“Installing the Slide Rails onto a ZS5-4”](#) on page 123
- [“Installing the Slide Rails into the Rack for a ZS5-4”](#) on page 124
- [“Installing a ZS5-4 onto the Rack Slide Rails”](#) on page 126
- [“Installing a ZS5-4 Cable Management Arm”](#) on page 128
- [“Verifying Operation of ZS5-4 Slide-Rails and CMA”](#) on page 130

▼ Installing the Slide Rails onto a ZS5-4

Use the following procedure to install the slide rails onto a ZS5-4 controller.

Note - The slide rails can be used with either 9.5-mm square or M6 round mounting hole racks.

1. **Position a mounting bracket against the chassis so that the slide-rail lock is at the front of the chassis, and the five keyhole openings on the mounting bracket are aligned with the five locating pins on the side of the chassis.**

Note - The mounting brackets are identical and can be installed on either side of the chassis.

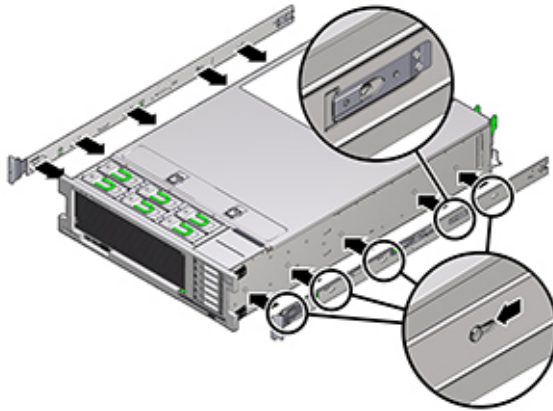

2. **With the heads of the five chassis locating pins protruding through the five keyhole openings in the mounting bracket, pull the mounting bracket toward the front of the chassis until the mounting bracket clip locks into place with an audible click.**
3. **Verify that the rear locating pin has engaged the mounting bracket clip.**
4. **To install the other mounting bracket on the other side of the chassis, repeat Steps 1 through 3.**

▼ Installing the Slide Rails into the Rack for a ZS5-4

Use the following procedure to install the slide rails into the rack for a ZS5-4 controller.

If you plan to move the rack after the controller is installed, use mounting screws and cage nuts to secure the slide-rail assembly. Refer to *Rail Rackmount Kit Overview and Information* card for instructions on inserting these cage nuts. This card is included with the rack kit.

1. **Position a slide-rail assembly in your rack so that the slide-rail assembly front bracket is on the outside of the front rack post and the slide-rail assembly rear bracket is on the inside of the rear rack post.**

2. **Align the slide-rail assembly mounting pins with the front and rear rack post mounting holes. Then lock the assembly into place by pushing the assembly toward the rear of the rack until the mounting pins engage the rack with an audible click.**

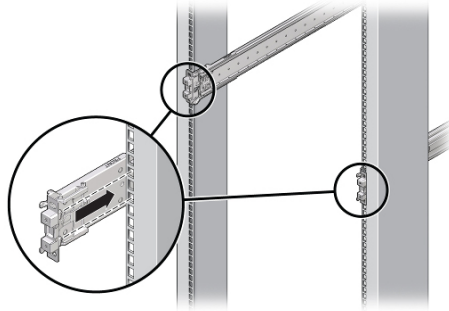

Note - The slide rails can be used with either 9.5-mm square or M6 round mounting hole racks.

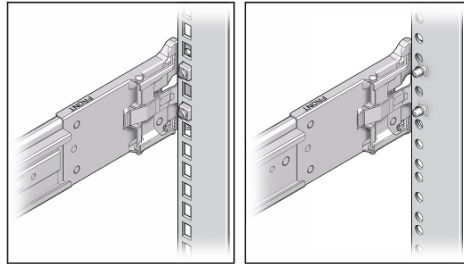

3. **(Optional) If installing the assembly with cage nuts and mounting screws, insert the cage nuts into the front and rear rack posts in the desired positions. Then**

insert the mounting screws through the front and rear slide-rail brackets and rack posts.

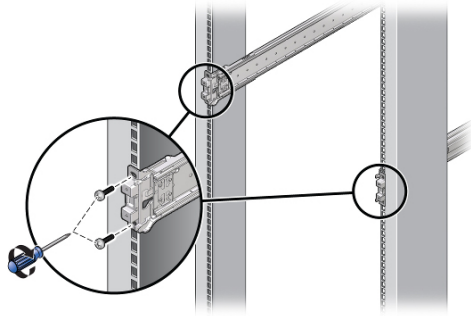

4. Repeat Step 1 to Step 3 for the other slide-rail assembly.

▼ Installing a ZS5-4 onto the Rack Slide Rails

Use the following procedure to install a ZS5-4 controller onto the rack slide rails.



Caution - This procedure requires a minimum of two people, or a mechanical lift, because of the weight of the chassis. Attempting this procedure alone could result in equipment damage or personal injury. Always load the heaviest equipment (disk shelves) at the bottom of the rack.

1. If your rack includes an anti-tip foot, extend it from the bottom of the rack.

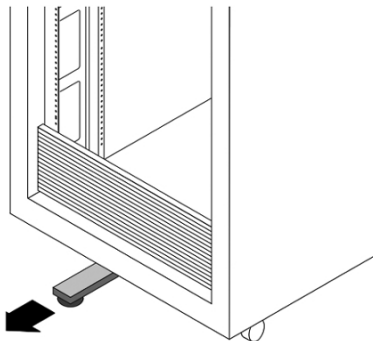

2. Lower the rack stabilization feet if you have not already done so.
3. Push the slide rails into the slide-rail assemblies in the rack as far as possible.
4. Raise the chassis so that the back ends of the mounting brackets are aligned with the slide rail and insert the chassis into the slide rails, pushing the chassis slowly, until the mounting brackets meet the slide-rail stops (approximately 12 inches, or 30 cm).



Caution - When inserting the controller into the slide rail, ensure that both the top and bottom mounting lips of the mounting brackets are inserted into the slide rail. The controller should slide forward and backward easily if correctly installed. If the unit does not slide easily, ensure that each mounting lip is inserted properly. If the mounting brackets are not inserted properly, the unit may fall when removing it from the rack, causing equipment damage and possibly personal injury.

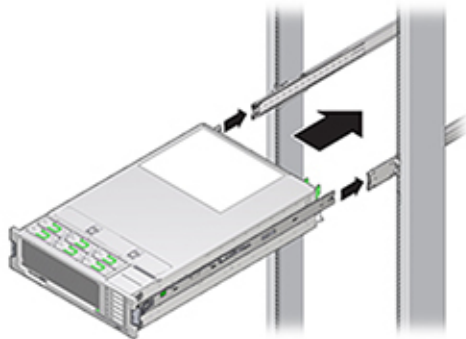

5. Simultaneously push and hold the green slide-rail release buttons on each mounting bracket while you push the chassis into the rack. Continue pushing

until the slide-rail locks (on the front of the mounting brackets) engage the slide-rail assemblies.

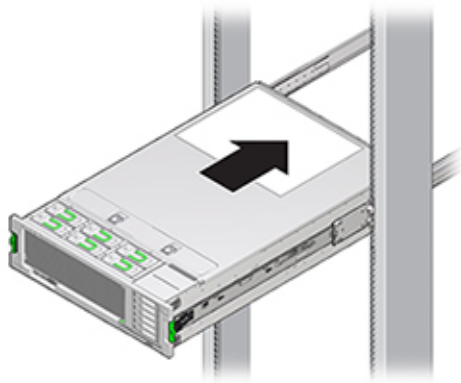

Caution - Verify that the controller is securely mounted in the rack and that the slide-rail locks are engaged with the mounting brackets before continuing, or equipment damage or possibly injury could occur.

▼ Installing a ZS5-4 Cable Management Arm

Use the following procedure to install the cable management arm (CMA) for a ZS5-4 controller.

The CMA is an optional assembly that you can use to route the controller cables in the rack. This procedure is completed from the back of the rack.

Before You Begin Unpack the CMA and identify its components.

To prepare for installing the optional cable management arm (CMA), follow these guidelines:

- Route cluster cables, long-term host cables (including InfiniBand, Fibre Channel, and Ethernet cables) and up to 16 disk shelf SAS cables through the CMA. Older CMAs, generally before 2018, only have a maximum capacity of 12 SAS cables.
- Do not route short SAS daisy chain cables through the CMA. Do not route an excess of cables such that the CMA clamps bow or appear structurally unfit to support the weight.
- If using two clustered controllers mounted in the middle of the rack with disk shelves located above and below them, you can divide the disk shelf SAS cables between the two CMAs so they properly route to the upper and lower disk shelves.

- If later removing the CMA, be sure to support it as you remove the connectors.

1. Insert the CMA mounting bracket connector (1) into the right slide rail (2) until the connector locks into place with an audible click.

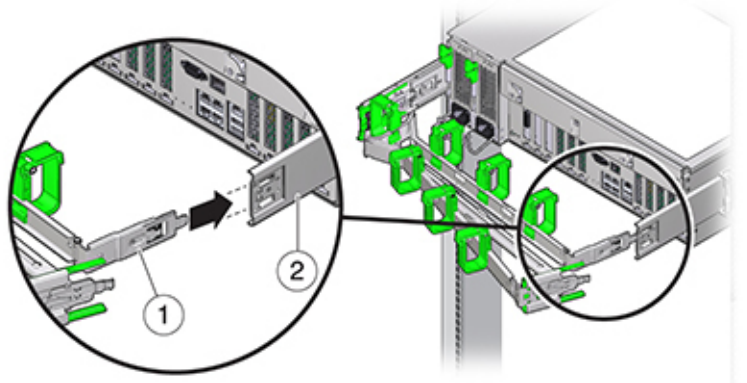

2. Insert the right CMA slide-rail connector (1) into the right slide-rail assembly (2) until the connector locks into place with an audible click.

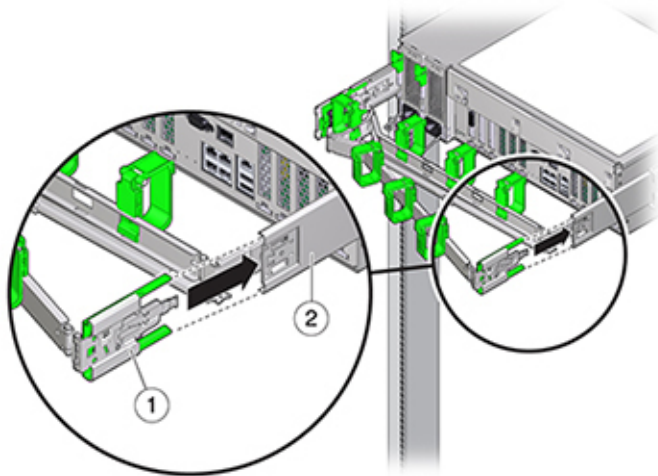

3. Insert the left CMA slide-rail connector into the left slide-rail assembly until the connector locks into place with an audible click.

4. **Install and route cables to the controller, as required.**
5. **If required, attach the cable hook and loop straps to the CMA, and press them into place to secure the cables.**

Note - Cable hooks and loop straps are preinstalled on the CMA. Perform this step if you need to reinstall cable hooks and straps.

6. **For best results, place three cable straps (1), evenly spaced, on the rear-facing side of the CMA arm (2), and three cable straps on the side of the CMA nearest the controller.**

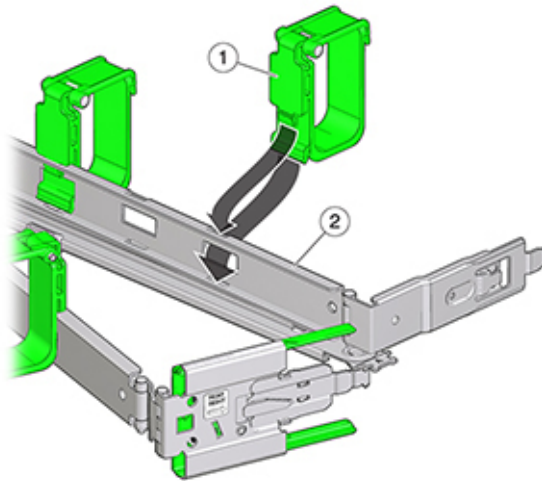

▼ Verifying Operation of ZS5-4 Slide-Rails and CMA

Use the following procedure to verify the operation of the CMA and slide rails for a ZS5-4 controller.

Before You Begin Ensure all rack anti-tilt devices are extended to prevent the rack from tipping forward when the storage controller is extended from the rack.

1. **Slowly pull the storage controller out of the rack until the slide-rails reach their stops.**
2. **Inspect the attached cables for any binding or kinks.**

3. **Verify that the CMA extends fully with the slide-rails.**
4. **Push the storage controller back into the rack and verify that the CMA retracts without binding.**
5. **Adjust the cable straps and the CMA, as required.**

Installing a ZS5-2 Controller

This section contains installation procedures for the ZS5-2 controller.

Before beginning installation, see [“Installation Prerequisites and Hardware Overviews”](#) on page 13.

Use the following procedures to install a ZS5-2 controller:

- [“Installing the Mounting Brackets and Slide Rail Assemblies for a ZS5-2”](#) on page 133
- [“Installing a ZS5-2 onto the Rack Slide Rails”](#) on page 139
- [“Installing a ZS5-2 Cable Management Arm”](#) on page 140
- [“Verifying Operation of ZS5-2 Slide-Rails and CMA”](#) on page 150

▼ **Installing the Mounting Brackets and Slide Rail Assemblies for a ZS5-2**

Use the following procedure to install the mounting brackets and slide rail assemblies for a ZS5-2 controller.

1. **Unpack the slide rails and locate the slide rail lock at the front of the assembly.**
2. **Squeeze and hold the tabs at top and bottom of the lock (1) while you pull the mounting bracket out to the stop.**

3. Push the mounting bracket release button toward the front of the mounting bracket (2) while withdrawing the bracket from the assembly.

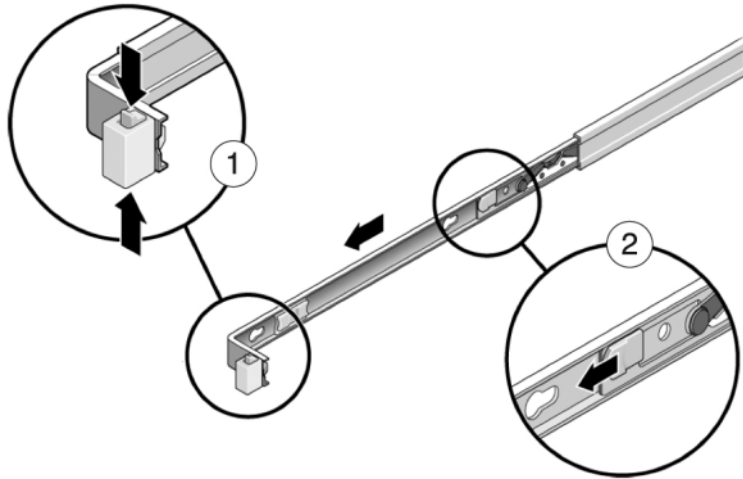

4. Attach a mounting bracket to each side of the controller.

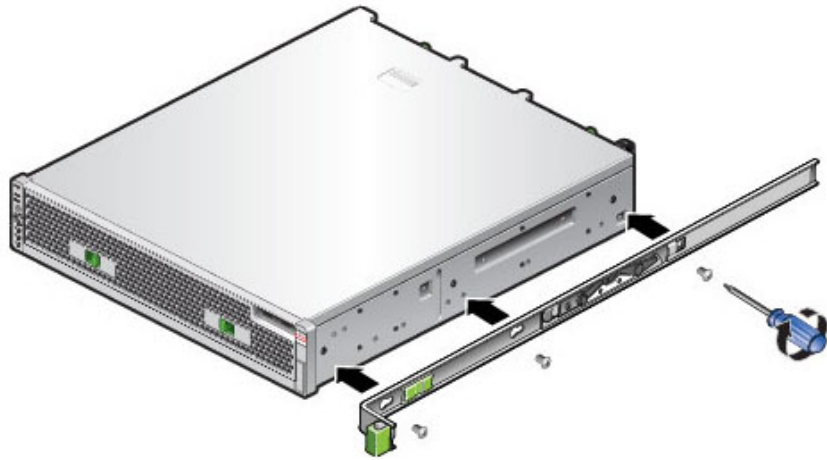

5. If you are using a universal 19-inch cabinet, snap an M6 square cage nut into the top and bottom holes of the location where you will be installing the rail plate as shown.

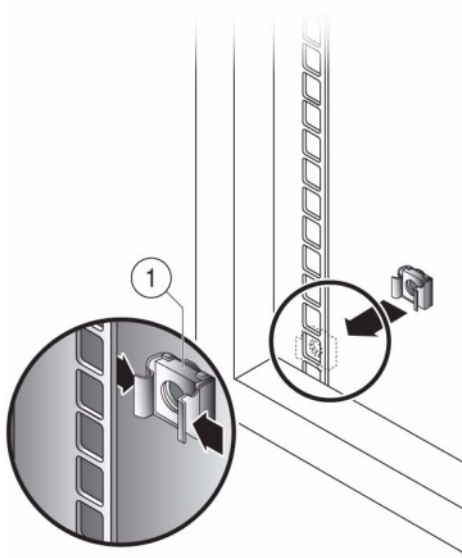

6. **Position a slide rail assembly in your rack so that the brackets at each end of the slide rail assembly are on the outside of the front and back rack posts. The following graphic illustrates the rail assembly brackets.**

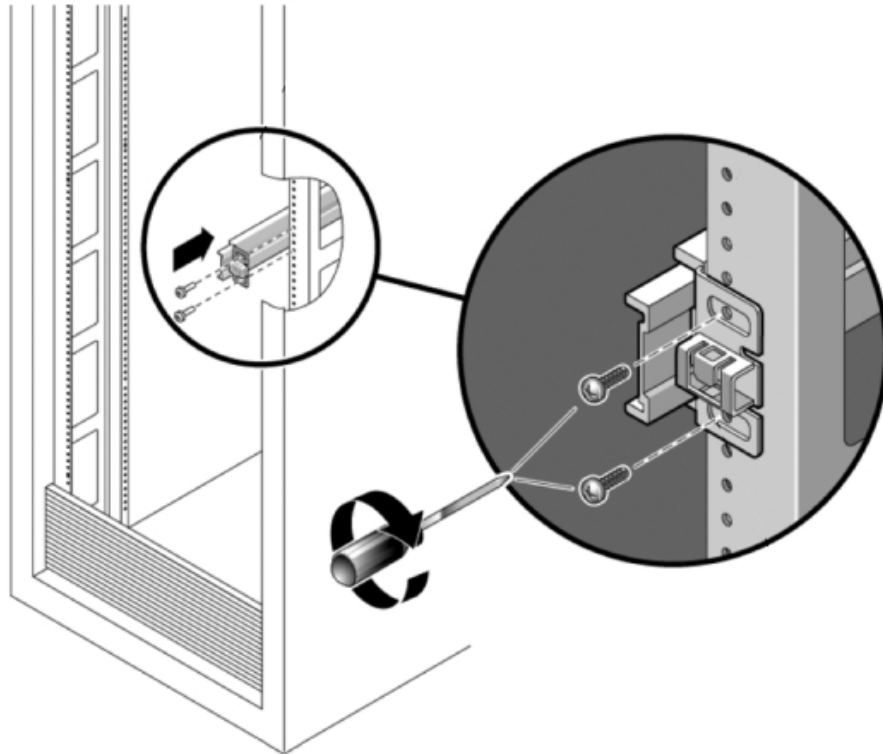

7. **Attach each slide rail assembly to the rack posts, but do not tighten the screws completely.**

8. From the front of the rack, set the proper width of the rails with the width spacer alignment tool (1).

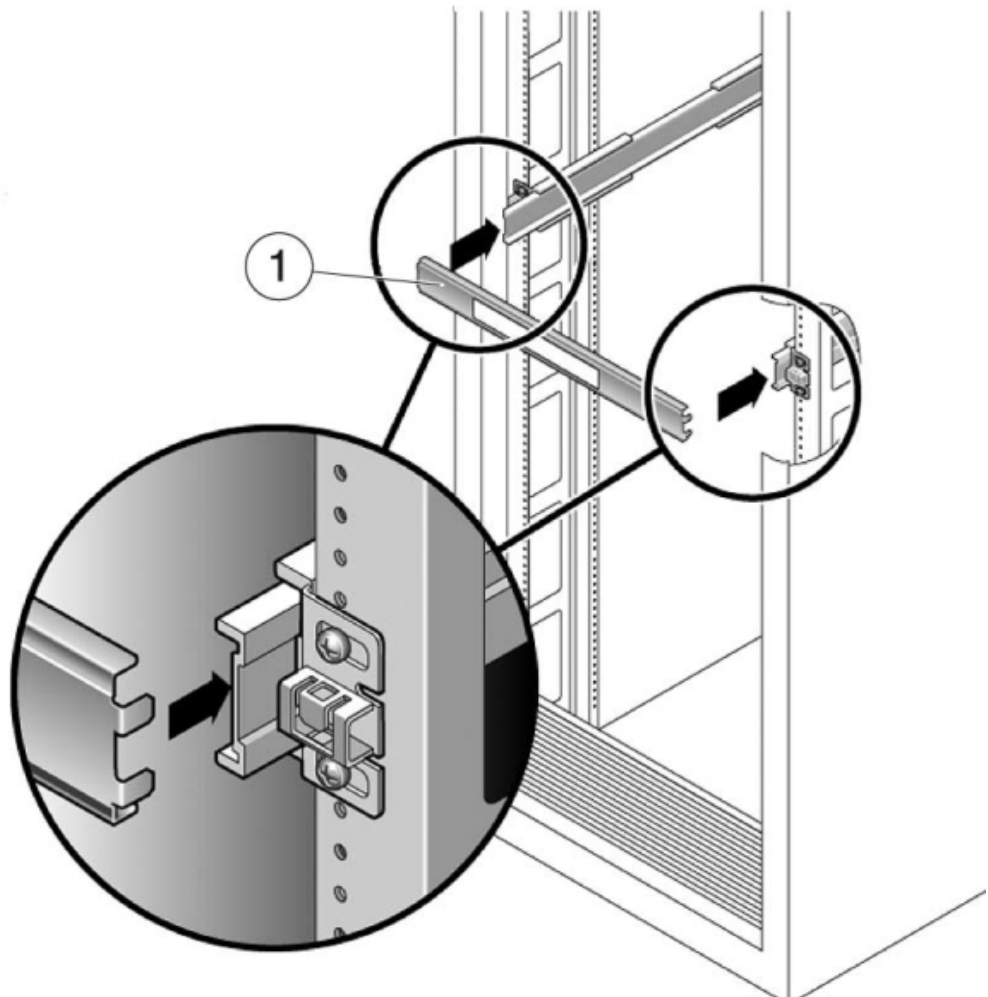

9. Tighten the screws on the brackets. (30 lb. torque)
10. Remove the spacer and confirm that the rails are attached tightly to the rack.
11. Stabilize the rack, using all anti-tilt mechanisms, to prevent it from tipping during installation. See your rack documentation for detailed instructions.

▼ Installing a ZS5-2 onto the Rack Slide Rails

Use the following procedure to install a ZS5-2 controller onto the rack slide rails.



Caution - This procedure requires a minimum of two people because of the weight of the chassis. Attempting this procedure alone could result in equipment damage or personal injury. Always load equipment into rack from the bottom up.

1. **If your rack includes an anti-tip foot, extend it from the bottom of the rack.**

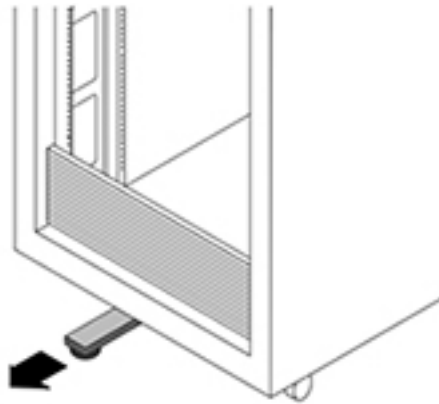

2. **Lower the rack stabilization feet if you have not already done so.**
3. **Pull the slide rails (mounted in the slide-rail assembly) toward you until the slide rails stop (approximately 12 inches (30 cm) out of the rack).**
4. **Raise the chassis so that the back ends of the mounting brackets are aligned with the slide rail and insert the chassis into the slide rails, pushing the chassis slowly, until the mounting brackets meet the slide rail stops (approximately 12 inches (30 cm) out of the rack). You will hear an audible click.**

5. The following graphic illustrates the chassis insertion and slide rail locks usage.

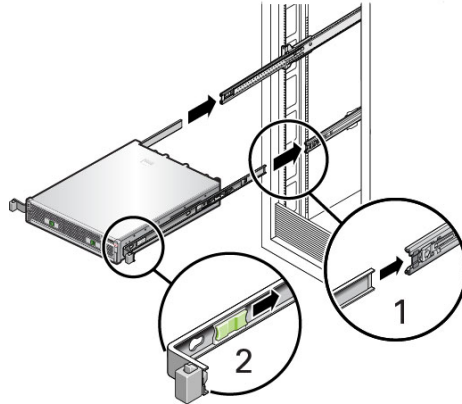

▼ Installing a ZS5-2 Cable Management Arm

Use the following procedure to install the cable management arm (CMA) on a ZS5-2 controller.

The CMA is an optional assembly that you can use to route the controller cables in the rack. This procedure is completed from the back of the rack.

Before You Begin Unpack the CMA and identify its components.

To prepare for installing the cable management arm (CMA), follow these guidelines:

- Route cluster cables, long-term host cables (including InfiniBand, Fibre Channel, and Ethernet Cables) and up to 12 disk shelf SAS cables through the CMA.
 - Do not route short SAS daisy chain cables through the CMA. Do not route an excess of cables such that the CMA clamps bow or appear structurally unfit to support the weight.
 - If using two clustered controllers mounted in the middle of the rack with disk shelves located above and below them, you can divide the disk shelf SAS cables between the two CMAs so they properly route to the upper and lower disk shelves.
 - If later removing the CMA, be sure to support it as you remove the connectors.
1. **If the CMA has flat cable covers (for a 1U chassis), install the 2U round cable covers provided in the accessory kit.**
 2. **To replace the flat cable covers:**

- a. **Remove each flat cable cover by lifting up on the cable cover handle.**
- b. **Open it 180 degrees to the horizontal position.**
- c. **Apply upward pressure to the outside edge of each hinge connector until the hinge connector comes off the hinge.**
- d. **Position each round cable cover horizontally over the hinges, and align the hinge connectors with the hinges.**
- e. **Using your thumb, apply downward pressure on each hinge connector to snap the hinge connector into place.**

- f. Swing the cable covers down and press down on the cable cover handle to lock them into the closed position.

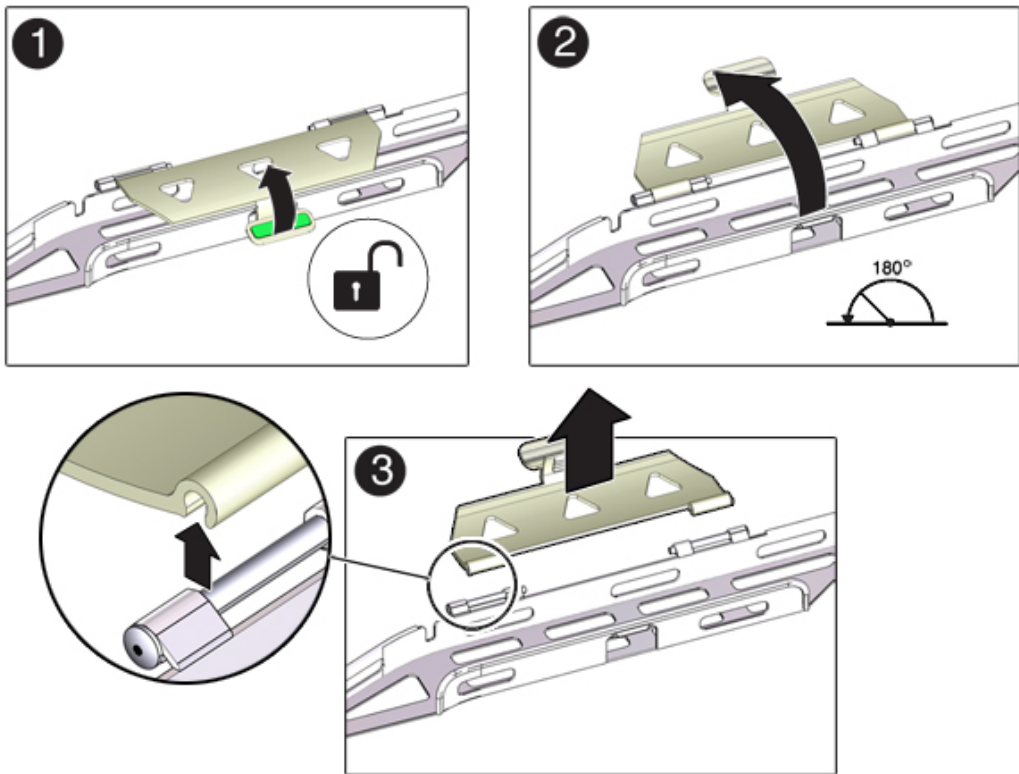

3. Ensure that the six Velcro straps are threaded into the CMA.
4. To prevent the rack from tipping, ensure all anti-tilt devices on the rack are extended.
5. Extend the storage controller approximately 13 cm (5 inches) out of the front of the rack.
6. At the back of the rack, insert the CMA's connector A into the front slot on the left side-rail until it locks into place with an audible click (frames 1 and 2).

The connector A tab (1) goes into the slide-rail's front slot (2). Gently tug on the left side of the front slide bar to verify that connector A is properly seated.

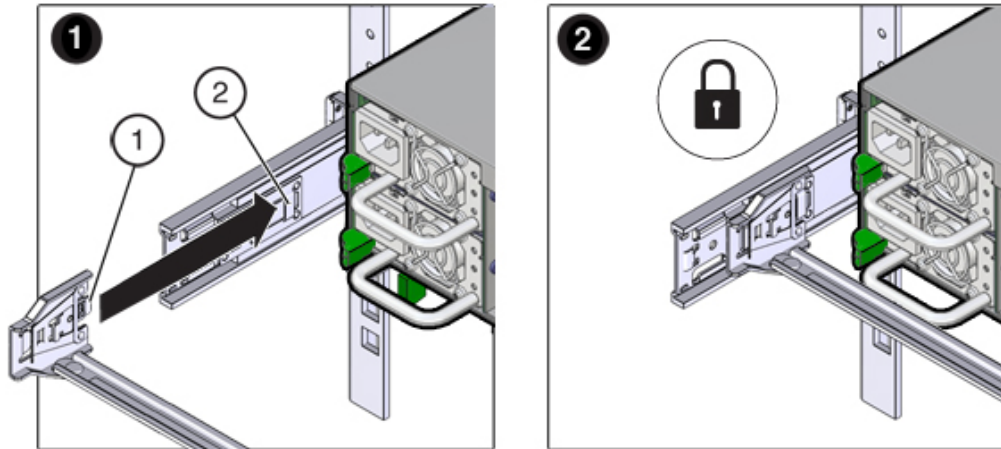

7. **Support the CMA and do not allow it to hang under its own weight until it is secured at all four attachment points.**
8. **Insert the CMA's connector B into the front slot on the right slide-rail until it locks into place with an audible click (frames 1 and 2).**

The connector B tab (1) goes into the slide-rail front slot (2). Gently tug on the right side of the front slide bar to verify that connector B is properly seated.

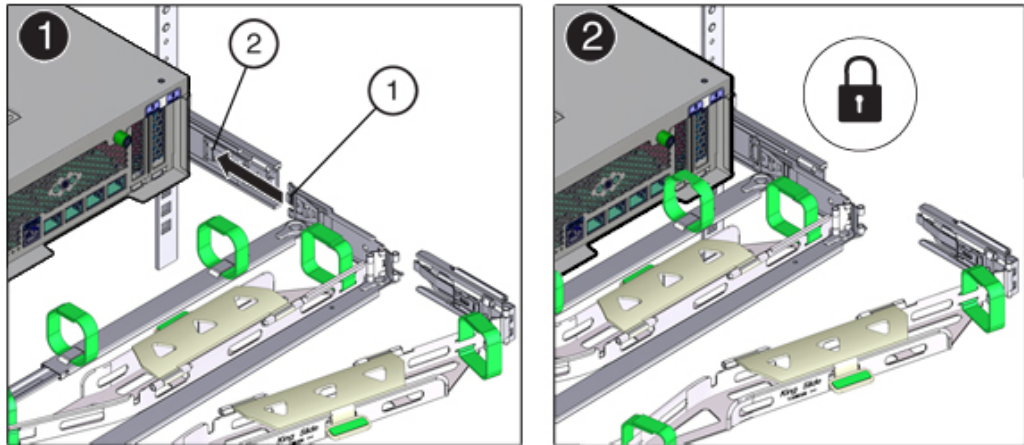

9. To install the CMA's connector C into the right slide-rail, perform the following steps:
 - a. Align connector C with the slide-rail so that the locking spring (1) is positioned inside (server side) of the right slide-rail (frame 1).
 - b. Insert connector C into the right side-rail until it locks into place with an audible click (frames 2 and 3).

- c. Gently tug on the right side of the CMA's rear slide bar to verify that connector C is properly seated.

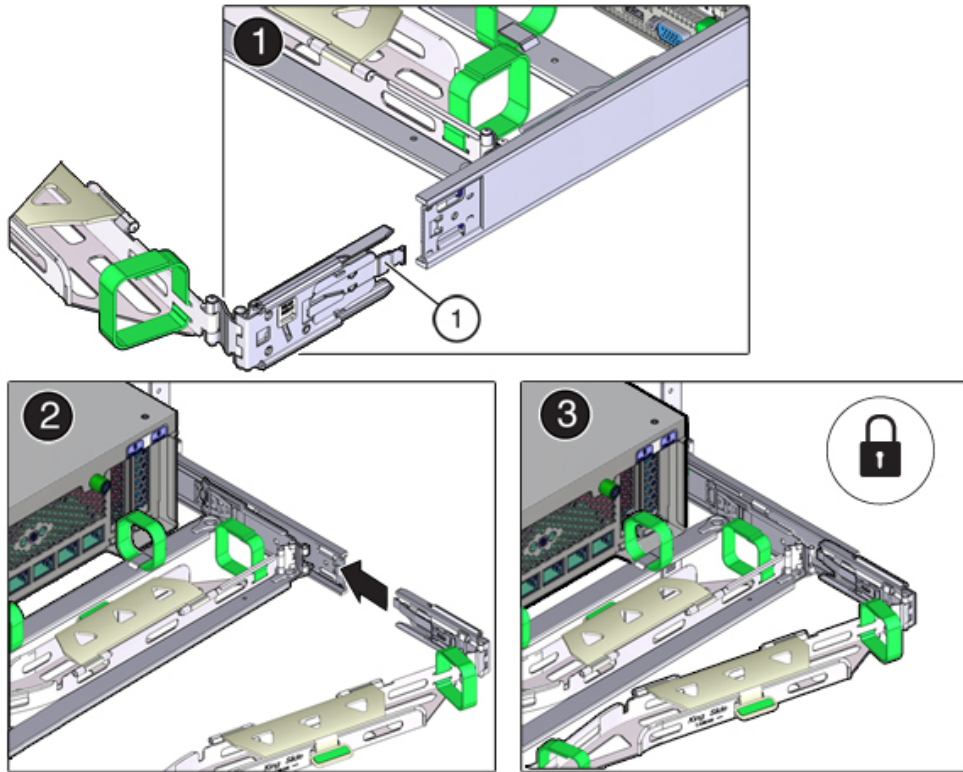

10. To prepare the CMA's connector D for installation, remove the tape that secures the slide-rail latching bracket to connector D and ensure that the latching bracket is properly aligned with connector D (frames 1 and 2).

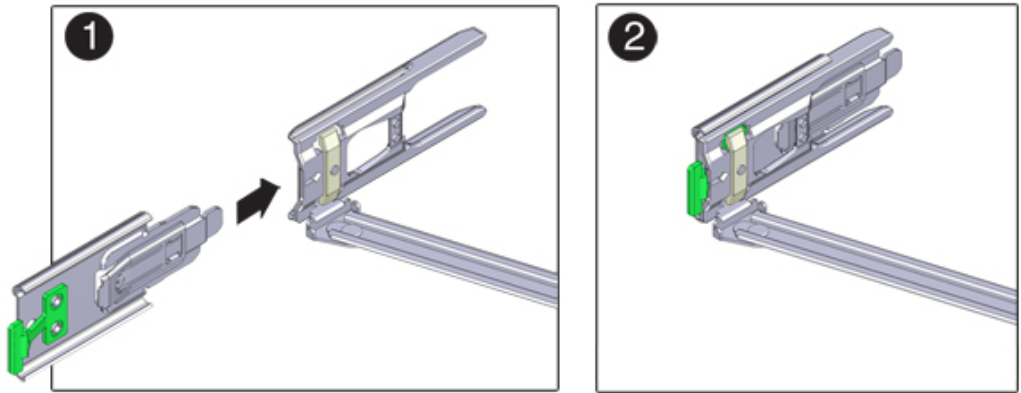

11. While holding the slide-rail latching bracket in place, insert connector D and its associated slide-rail latching bracket into the left slide-rail until connector D locks into place with an audible click (frames 1 and 2).

When inserting connector D into the slide-rail, the preferred and easier method is to install connector D and the latching bracket as one assembly into the slide-rail.

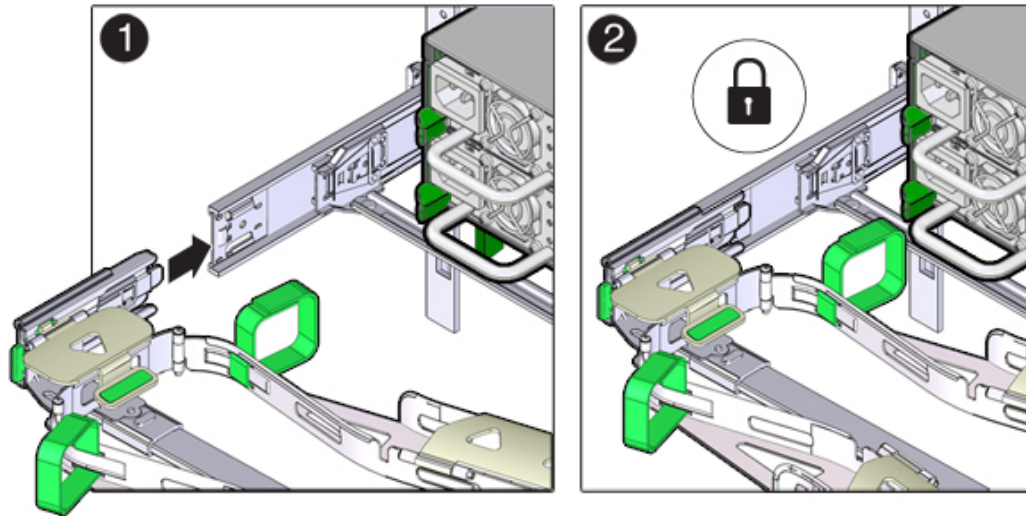

12. Gently tug on the left side of the CMA's rear slide bar to verify that connector D is properly seated.
13. Gently tug on the four CMA connection points to ensure that the CMA connectors are fully seated before you allow the CMA to hang by its own weight.
14. Verify that the slide-rails and the CMA are operating properly before routing cables through the CMA:
 - a. Ensure all rack anti-tilt devices are extended to prevent the rack from tipping.

- b. **Extend the controller from the front of the rack until the CMA is fully extended.**

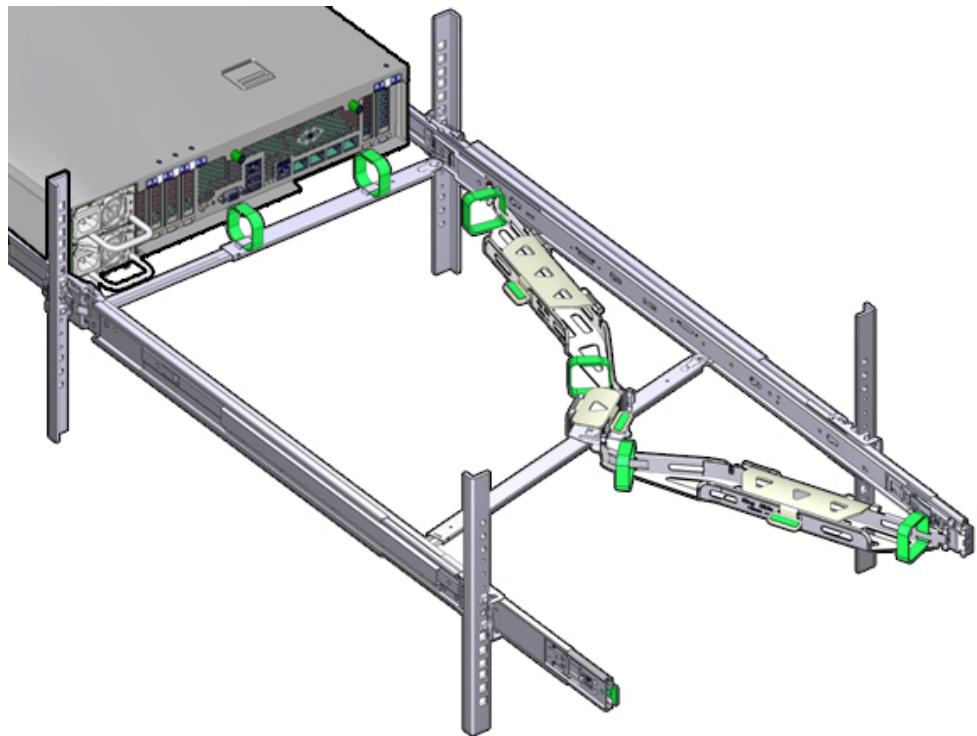

15. **Return the storage controller to the rack. As you push the storage controller into the rack, verify that the CMA retracts without binding.**
16. **Open the CMA cable covers, route controller cables through the CMA's cable troughs, close the cable covers, and secure the cables with the six Velcro straps. Route the cables through the cable troughs in this order: Route the cables**

through the front-most cable trough, then through the small cable trough, then through the rear-most cable trough.

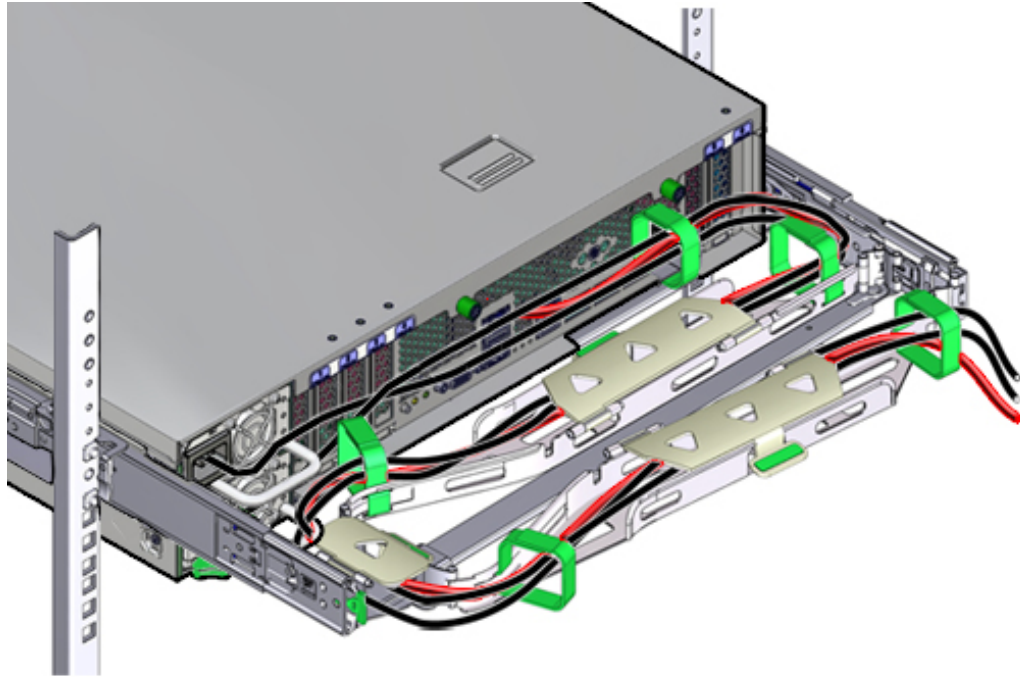

17. **When securing the cables with the Velcro straps located on the front slide bar, ensure that the Velcro straps do not wrap around the bottom of the slide bar.**
Otherwise, expansion and contraction of the slide bar might be hindered when the server is extended from the rack and returned to the rack.
18. **Ensure that the secured cables do not extend above the top or below the bottom of the server to which they are attached.**
Otherwise, the cables might snag on other equipment installed in the rack when the server is extended from the rack or returned to the rack.
19. **If necessary, bundle the cables with additional Velcro straps to ensure that they stay clear of other equipment.**
If you need to install additional Velcro straps, wrap the straps around the cables only, not around any of the CMA components; otherwise, expansion and contraction of the CMA slide bars might be hindered when the server is extended from the rack and returned to the rack.

▼ **Verifying Operation of ZS5-2 Slide-Rails and CMA**

Use the following procedure to verify the operation of the CMA and slide rails for a ZS5-2 controller.

Before You Begin Ensure all rack anti-tilt devices are extended to prevent the rack from tipping forward when the storage controller is extended from the rack.

1. **Slowly pull the storage controller out of the rack until the slide-rails reach their stops.**
2. **Inspect the attached cables for any binding or kinks.**
3. **Verify that the CMA extends fully with the slide-rails.**
4. **Push the storage controller back into the rack and verify that the CMA retracts without binding.**
5. **Adjust the cable straps and the CMA, as required.**

Installing a ZS4-4 or ZS3-4 Controller

This section contains installation procedures for the ZS4-4 or ZS3-4 controller.

Before beginning installation, see [“Installation Prerequisites and Hardware Overviews”](#) on page 13.

Use the following procedures to install a ZS4-4 or ZS3-4 controller:

- [“Installing the Slide Rails onto a ZS4-4 or ZS3-4”](#) on page 151
- [“Installing the Slide Rails into the Rack for a ZS4-4 or ZS3-4”](#) on page 152
- [“Installing a ZS4-4 or ZS3-4 onto the Rack Slide Rails”](#) on page 154
- [“Installing a ZS4-4 or ZS3-4 Cable Management Arm”](#) on page 157

▼ Installing the Slide Rails onto a ZS4-4 or ZS3-4

Use the following procedure to install the slide rails onto a ZS4-4 or ZS3-4 controller.

Note - The slide rails can be used with either 9.5-mm square or M6 round mounting hole racks.

1. **Position a mounting bracket against the chassis so that the slide-rail lock is at the front of the chassis, and the five keyhole openings on the mounting bracket are aligned with the five locating pins on the side of the chassis.**

Note - The mounting brackets are identical and can be installed on either side of the chassis.

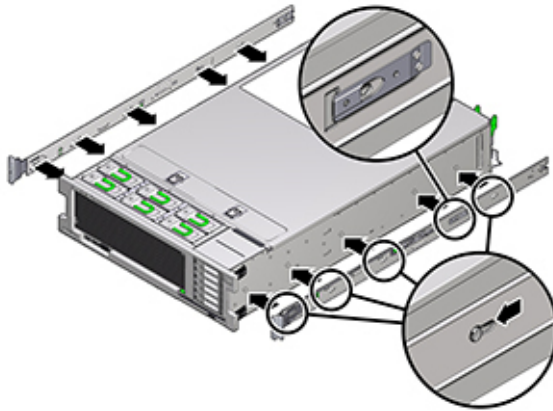

2. With the heads of the five chassis locating pins protruding through the five keyhole openings in the mounting bracket, pull the mounting bracket toward the front of the chassis until the mounting bracket clip locks into place with an audible click.
3. Verify that the rear locating pin has engaged the mounting bracket clip.
4. To install the other mounting bracket on the other side of the chassis, repeat Steps 1 through 3.

▼ Installing the Slide Rails into the Rack for a ZS4-4 or ZS3-4

Use the following procedure to install the slide rails into the rack for a ZS4-4 or ZS3-4 controller.

If you plan to move the rack after the controller is installed, use mounting screws and cage nuts to secure the slide-rail assembly. Refer to the Rail Rackmount Kit Overview and Information card for instructions on inserting these cage nuts. This card is included with the rack kit.

1. Position a slide-rail assembly in your rack so that the slide-rail assembly front bracket is on the outside of the front rack post and the slide-rail assembly rear bracket is on the inside of the rear rack post.
2. Align the slide-rail assembly mounting pins with the front and rear rack post mounting holes. Then lock the assembly into place by pushing the assembly toward the rear of the rack until the mounting pins engage the rack with an audible click.

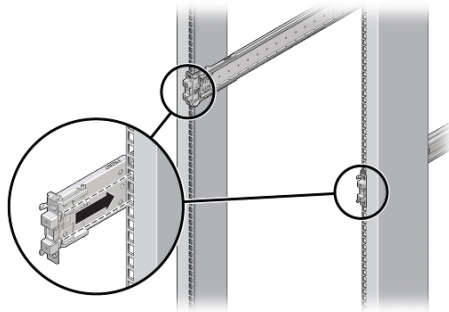

Note - The slide rails can be used with either 9.5-mm square or M6 round mounting hole racks.

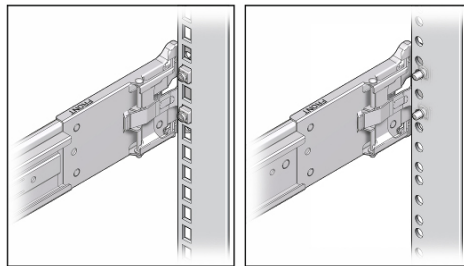

3. (Optional) If installing the assembly with cage nuts and mounting screws, insert the cage nuts into the front and rear rack posts in the desired positions. Then

insert the mounting screws through the front and rear slide-rail brackets and rack posts.

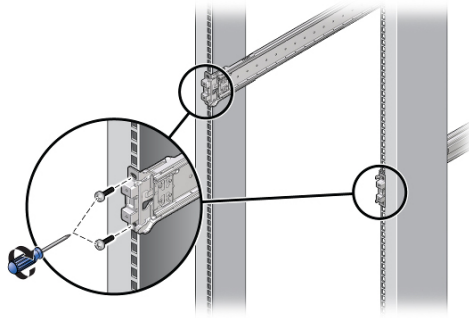

4. Repeat Steps 2 and 3 for the other slide-rail assembly.

▼ Installing a ZS4-4 or ZS3-4 onto the Rack Slide Rails

Use the following procedure to install a ZS4-4 or ZS3-4 controller onto the rack slide rails.



Caution - This procedure requires a minimum of two people, or a mechanical lift, because of the weight of the chassis. Attempting this procedure alone could result in equipment damage or personal injury. Always load the heaviest equipment (disk shelves) at the bottom of the rack.

1. **If your rack includes an anti-tip foot, extend it from the bottom of the rack.**

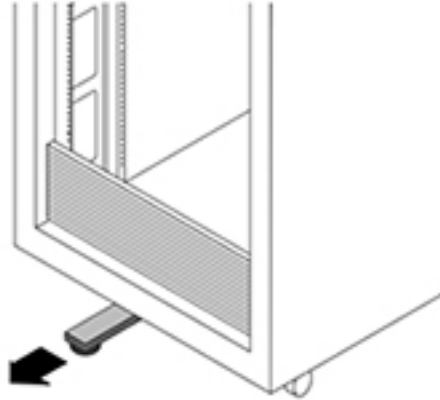

2. **Lower the rack stabilization feet if you have not already done so.**
3. **Push the slide rails into the slide-rail assemblies in the rack as far as possible.**
4. **Raise the chassis so that the back ends of the mounting brackets are aligned with the slide rail and insert the chassis into the slide rails, pushing the chassis slowly, until the mounting brackets meet the slide-rail stops (approximately 12 inches, or 30 cm).**



Caution - When inserting the controller into the slide rail, ensure that both the top and bottom mounting lips of the mounting brackets are inserted into the slide rail. The controller should slide forward and backward easily if correctly installed. If the unit does not slide easily, ensure that each mounting lip is inserted properly. If the mounting brackets are not inserted properly, the unit may fall when removing it from the rack, causing equipment damage and possibly personal injury.

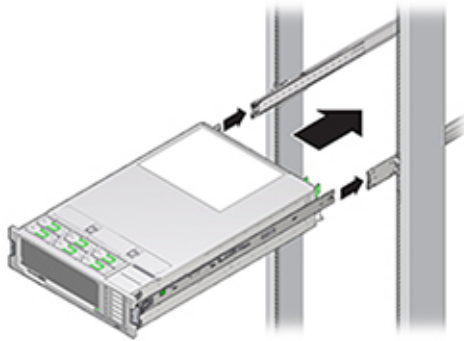

5. **Simultaneously push and hold the green slide-rail release buttons on each mounting bracket while you push the controller into the rack. Continue pushing until the slide-rail locks (on the front of the mounting brackets) engage the slide-rail assemblies with an audible click.**

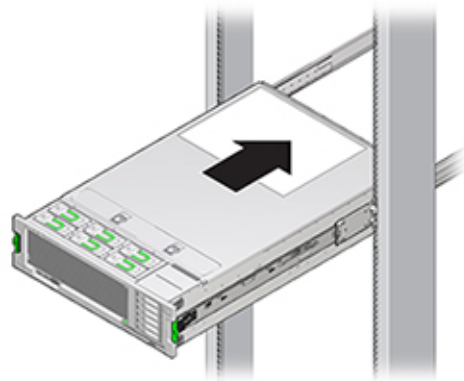



Caution - Verify that the controller is securely mounted in the rack and that the slide-rail locks are engaged with the mounting brackets before continuing, or equipment damage and possibly personal injury could occur.

▼ Installing a ZS4-4 or ZS3-4 Cable Management Arm

Use the following procedure to install the cable management arm (CMA) for a ZS4-4 or ZS3-4 controller.

The CMA is an optional assembly that you can use to route the controller cables in the rack. This procedure is completed from the back of the rack.

Before You Begin To prepare for installing the optional cable management arm (CMA), follow these guidelines:

- Route cluster cables, long-term host cables (including InfiniBand, Fibre Channel, and Ethernet Cables) and up to 12 disk shelf SAS cables through the CMA.
- Do not route short SAS daisy chain cables through the CMA. Do not route an excess of cables such that the CMA clamps bow or appear structurally unfit to support the weight.
- If using two clustered controllers mounted in the middle of the rack with disk shelves located above and below them, you can divide the disk shelf SAS cables between the two CMAs so they properly route to the upper and lower disk shelves.
- If later removing the CMA, be sure to support it as you remove the connectors.

1. **Insert the CMA mounting bracket connector (1) into the right slide rail (2) until the connector locks into place with an audible click.**

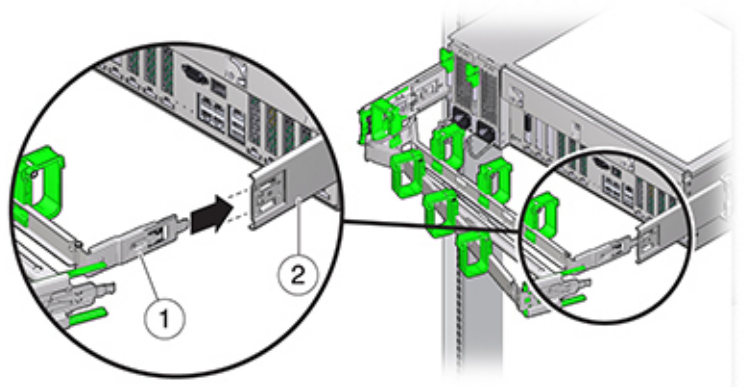

-
- 2. Insert the right CMA slide-rail connector (1) into the right slide-rail assembly (2) until the connector locks into place with an audible click.**

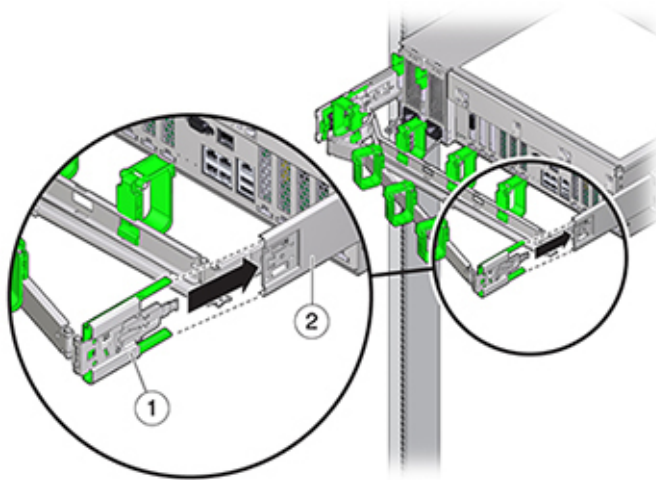

-
-
- 3. Insert the left CMA slide-rail connector into the left slide-rail assembly until the connector locks into place with an audible click.**
- 4. Install and route cables to the controller, as required.**
- 5. If required, attach the cable hook and loop straps to the CMA, and press them into place to secure the cables.**

Note - Cable hooks and loop straps are preinstalled on the CMA. Perform this step if you need to reinstall cable hooks and straps.

6. For best results, place three cable straps (1), evenly spaced, on the rear-facing side of the CMA arm (2), and three cable straps on the side of the CMA nearest the controller.

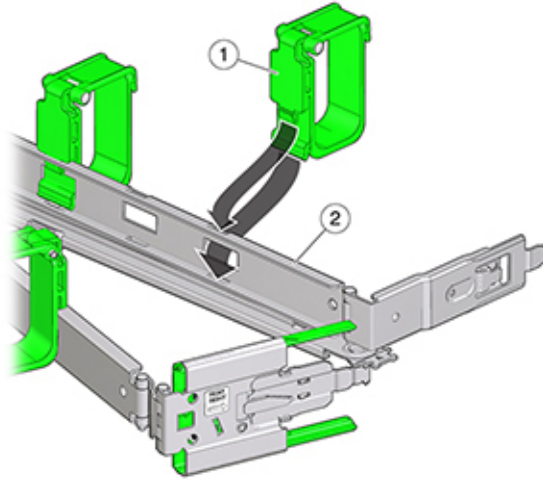

Installing a ZS3-2 Controller

This section contains installation procedures for the ZS3-2 controller.

Before beginning installation, see [“Installation Prerequisites and Hardware Overviews”](#) on page 13.

Use the following procedures to install a ZS3-2 controller:

- [“Installing the Mounting Brackets and Slide Rail Assemblies for a ZS3-2”](#) on page 161
- [“Installing a ZS3-2 onto the Rack Slide Rails”](#) on page 167
- [“Installing a ZS3-2 Cable Management Arm”](#) on page 168
- [“Verifying Operation of ZS3-2 Slide-Rails and CMA”](#) on page 177

▼ **Installing the Mounting Brackets and Slide Rail Assemblies for a ZS3-2**

Use the following procedure to install the mounting brackets and slide rail assemblies for a ZS3-2 controller.

1. **Unpack the slide rails and locate the slide rail lock at the front of the assembly.**
2. **Squeeze and hold the tabs at top and bottom of the lock (1) while you pull the mounting bracket out to the stop.**

3. Push the mounting bracket release button toward the front of the mounting bracket (2) while withdrawing the bracket from the assembly.

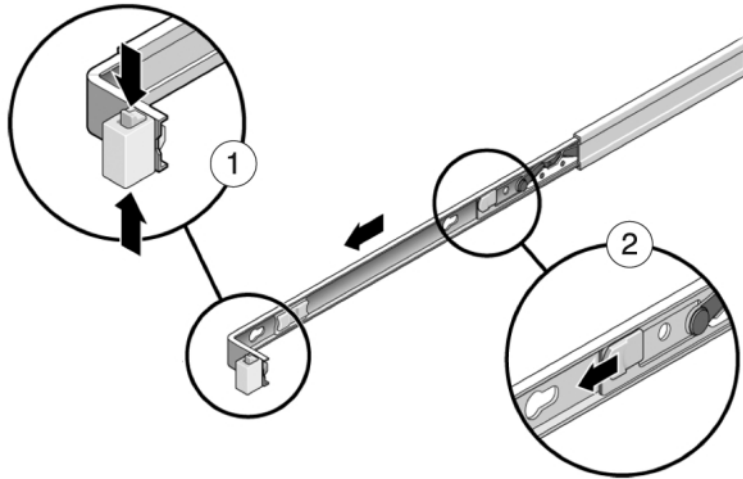

4. Attach a mounting bracket to each side of the controller.

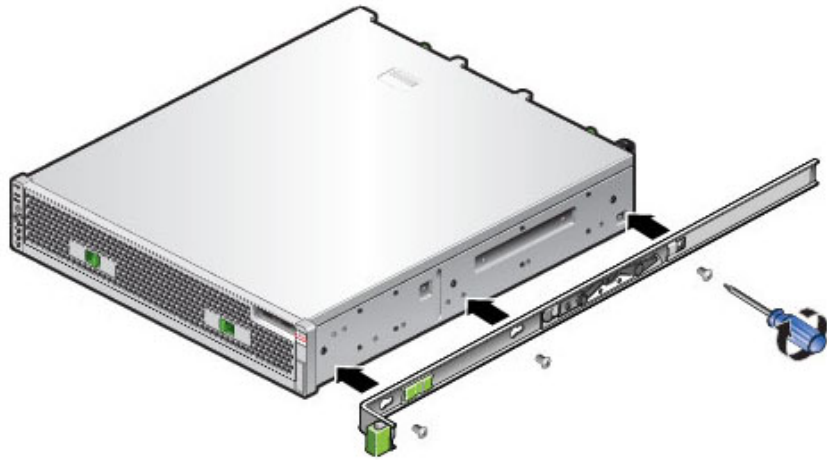

5. If you are using a universal 19-inch cabinet, snap an M6 square cage nut into the top and bottom holes of the location where you will be installing the rail plate as shown.

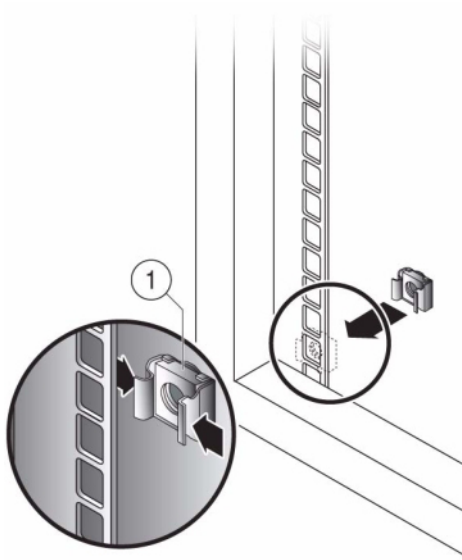

6. **Position a slide rail assembly in your rack so that the brackets at each end of the slide rail assembly are on the outside of the front and back rack posts. The following graphic illustrates the rail assembly brackets.**

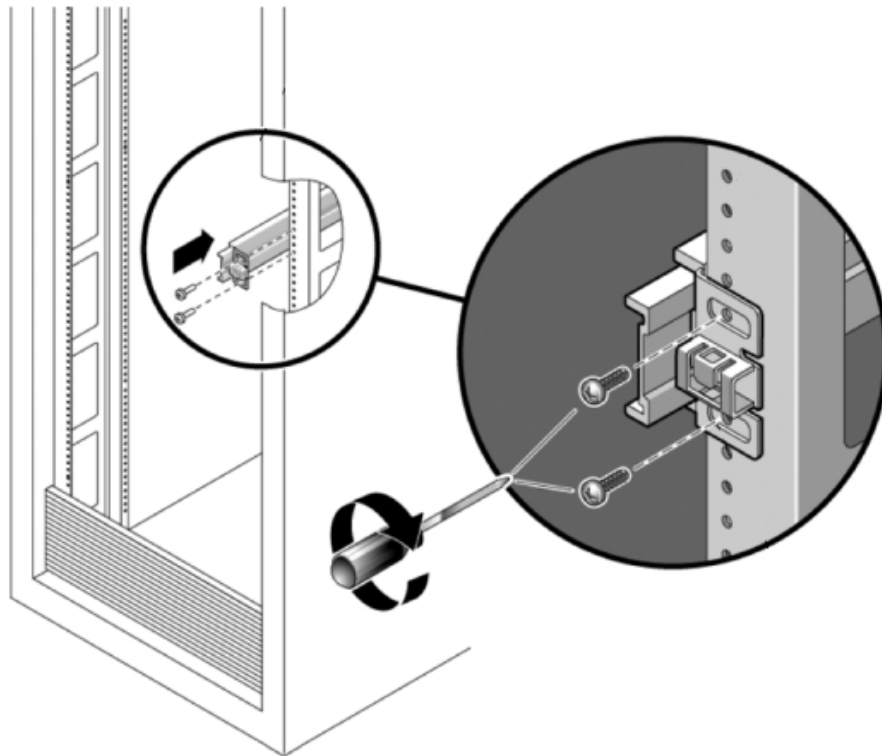

7. **Attach each slide rail assembly to the rack posts, but do not tighten the screws completely.**

8. From the front of the rack, set the proper width of the rails with the width spacer alignment tool (1).

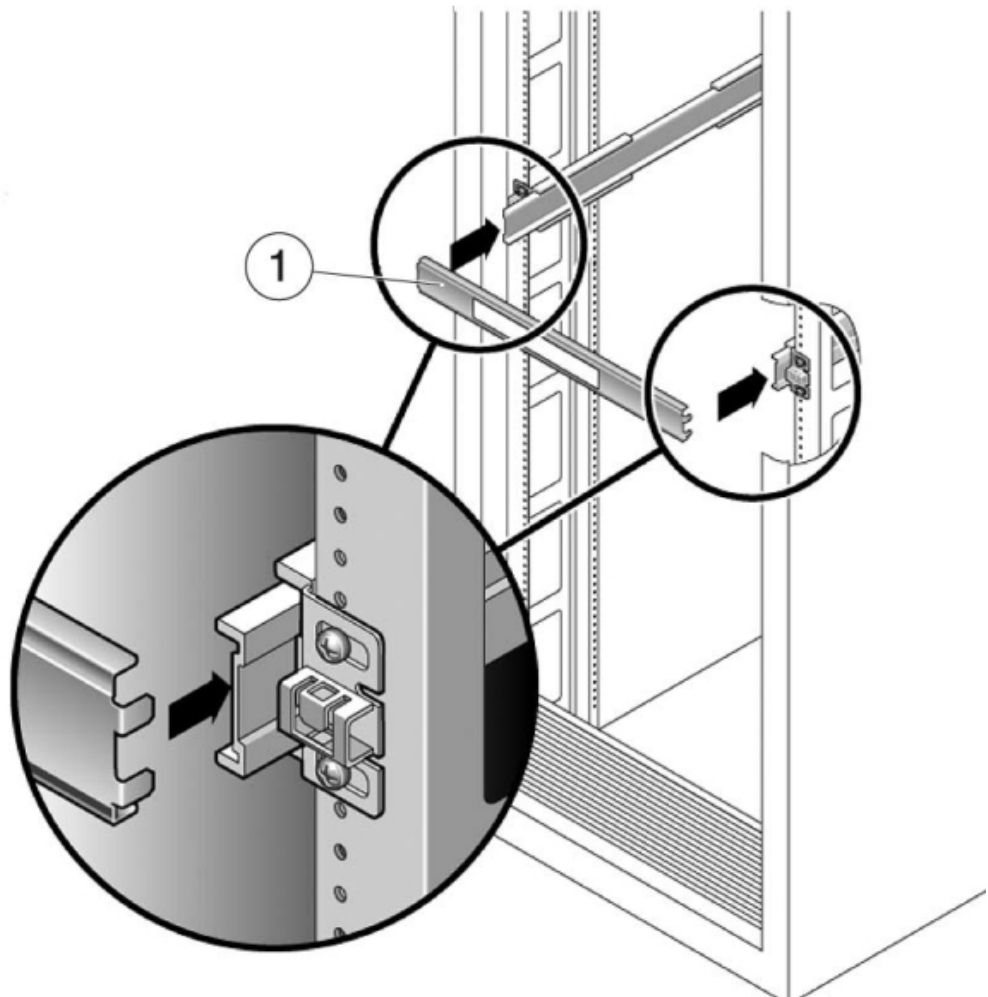

9. Tighten the screws on the brackets. (30 lb. torque)
10. Remove the spacer and confirm that the rails are attached tightly to the rack.
11. Stabilize the rack, using all anti-tilt mechanisms, to prevent it from tipping during installation. See your rack documentation for detailed instructions.

▼ Installing a ZS3-2 onto the Rack Slide Rails

Use the following procedure to install a ZS3-2 controller onto the rack slide rails.



Caution - This procedure requires a minimum of two people because of the weight of the chassis. Attempting this procedure alone could result in equipment damage or personal injury. Always load equipment into rack from the bottom up.

1. **If your rack includes an anti-tip foot, extend it from the bottom of the rack.**

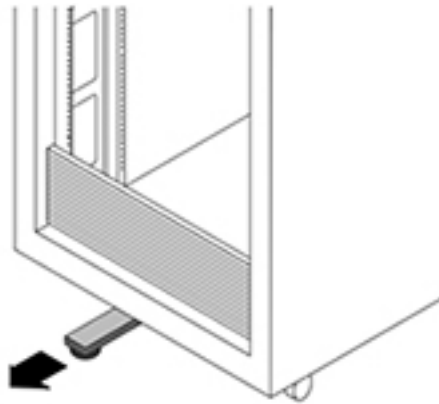

2. **Lower the rack stabilization feet if you have not already done so.**
3. **Pull the slide rails (mounted in the slide-rail assembly) toward you until the slide rails stop (approximately 12 inches, (30 cm) out of the rack).**
4. **Raise the chassis so that the back ends of the mounting brackets are aligned with the slide rail and insert the chassis into the slide rails, pushing the chassis slowly, until the mounting brackets meet the slide rail stops (~12 in or 30 cm). You will hear an audible click.**

5. The following graphic illustrates the chassis insertion and slide rail locks usage.

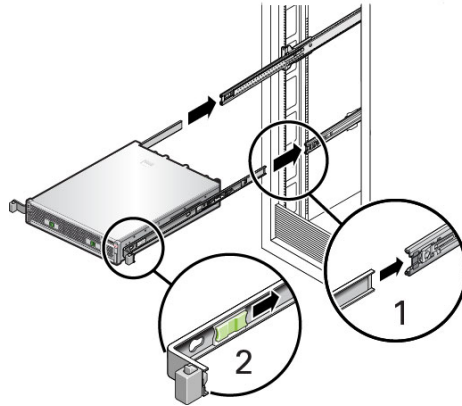

▼ Installing a ZS3-2 Cable Management Arm

Use the following procedure to install the optional cable management arm (CMA) on a ZS3-2 controller.

Before You Begin Unpack the CMA and identify its components.

To prepare for installing the optional cable management arm (CMA), follow these guidelines:

- Route cluster cables, long-term host cables (including InfiniBand, Fibre Channel, and Ethernet Cables) and up to 12 disk shelf SAS cables through the CMA.
 - Do not route short SAS daisy chain cables through the CMA. Do not route an excess of cables such that the CMA clamps bow or appear structurally unfit to support the weight.
 - If using two clustered controllers mounted in the middle of the rack with disk shelves located above and below them, you can divide the disk shelf SAS cables between the two CMAs so they properly route to the upper and lower disk shelves.
 - If later removing the CMA, be sure to support it as you remove the connectors.
1. **If the CMA has flat cable covers (for a 1U chassis), install the 2U round cable covers provided in the accessory kit.**
 2. **To replace the flat cable covers:**
 - a. **Remove each flat cable cover by lifting up on the cable cover handle.**

- b. Open it 180 degrees to the horizontal position.
- c. Apply upward pressure to the outside edge of each hinge connector until the hinge connector comes off the hinge.
- d. Position each round cable cover horizontally over the hinges, and align the hinge connectors with the hinges.
- e. Using your thumb, apply downward pressure on each hinge connector to snap the hinge connector into place.
- f. Swing the cable covers down and press down on the cable cover handle to lock them into the closed position.

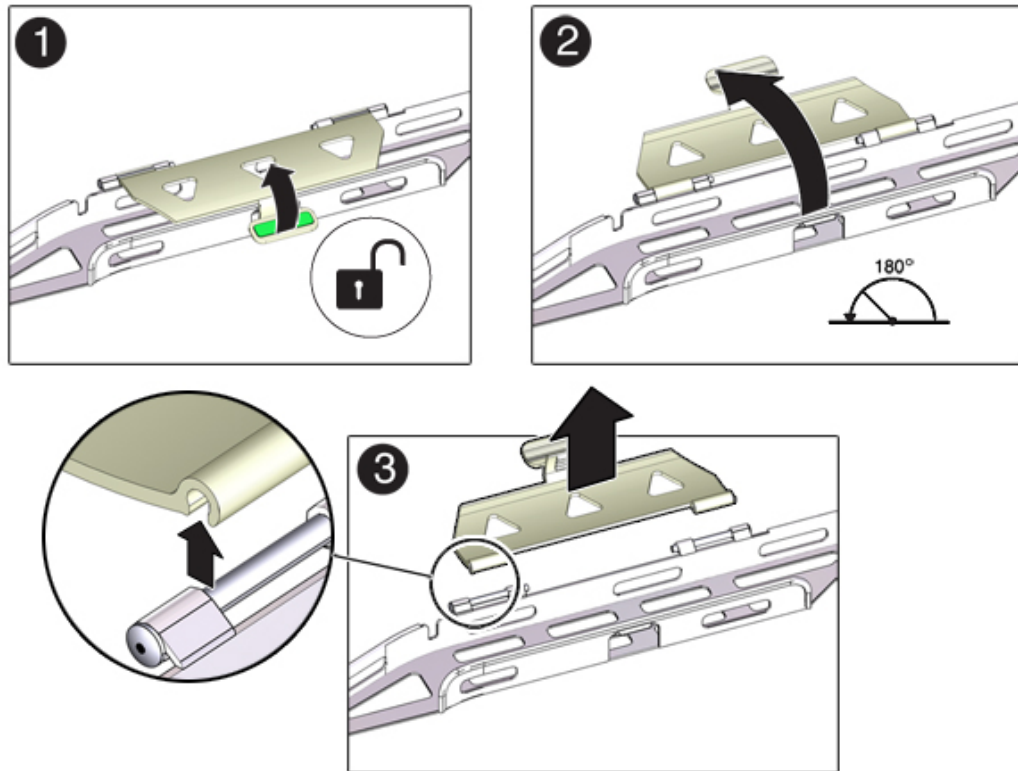

3. **Ensure that the six Velcro straps are threaded into the CMA.**
4. **To prevent the rack from tipping, ensure all anti-tilt devices on the rack are extended.**
5. **Extend the storage controller approximately 13 cm (5 inches) out of the front of the rack.**
6. **At the back of the rack, insert the CMA's connector A into the front slot on the left slide-rail until it locks into place with an audible click (frames 1 and 2).**

The connector A tab (1) goes into the slide-rail's front slot (2). Gently tug on the left side of the front slide bar to verify that connector A is properly seated.

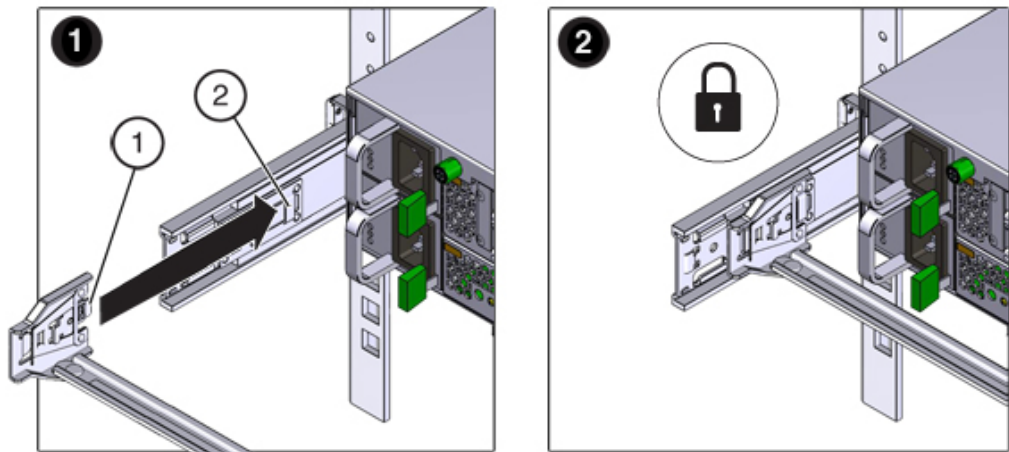

7. **Support the CMA and do not allow it to hang under its own weight until it is secured at all four attachment points.**
8. **Insert the CMA's connector B into the front slot on the right slide-rail until it locks into place with an audible click (frames 1 and 2).**

The connector B tab (1) goes into the slide-rail front slot (2). Gently tug on the right side of the front slide bar to verify that connector B is properly seated.

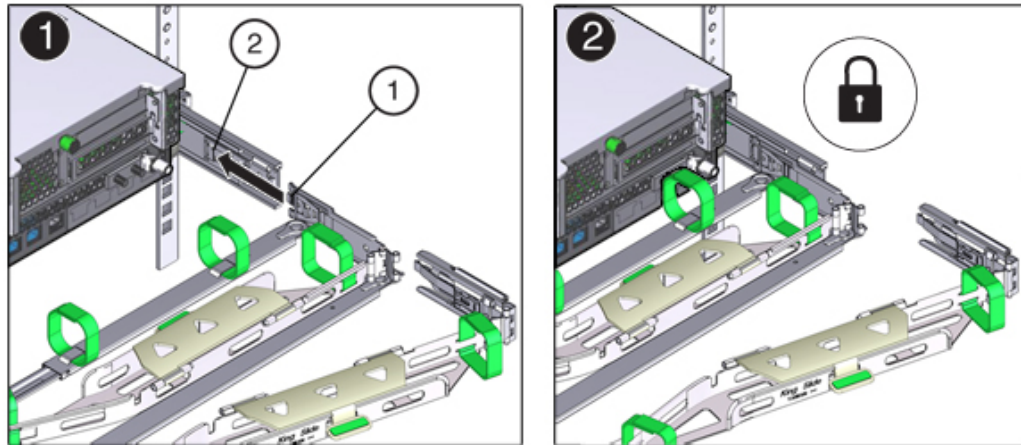

9. To install the CMA's connector C into the right slide-rail, perform the following steps:
 - a. Align connector C with the slide-rail so that the locking spring (1) is positioned inside (server side) of the right slide-rail (frame 1).
 - b. Insert connector C into the right side-rail until it locks into place with an audible click (frames 2 and 3).

- c. Gently tug on the right side of the CMA's rear slide bar to verify that connector C is properly seated.

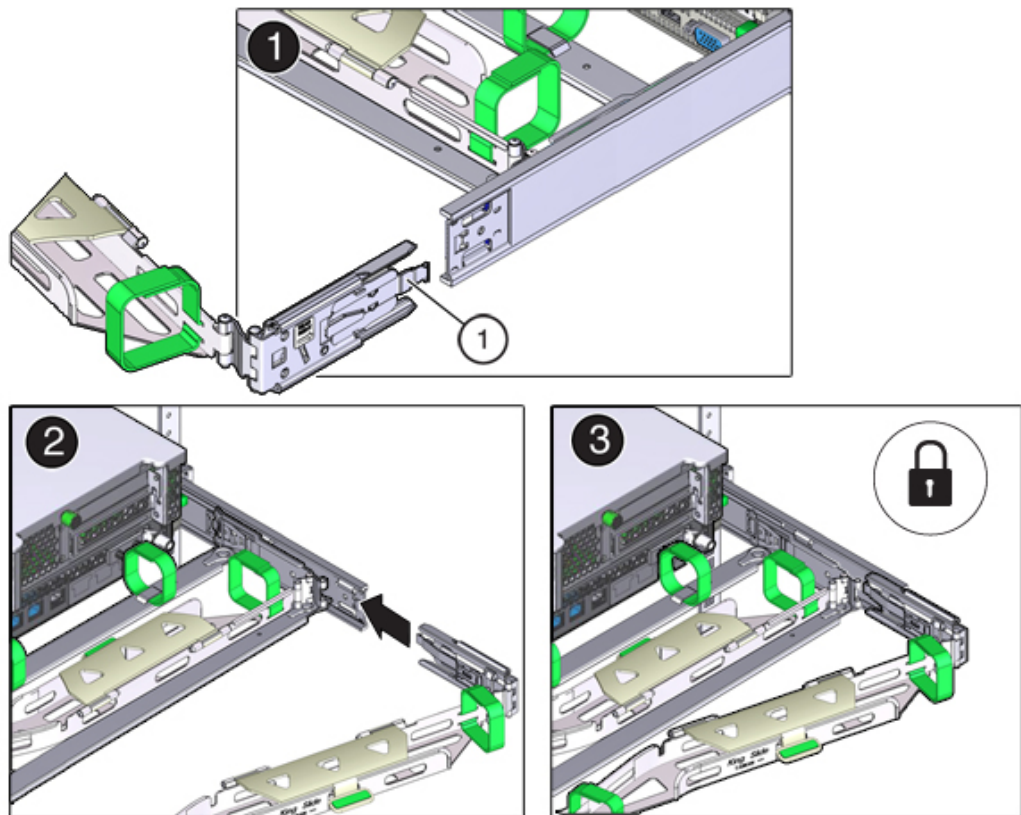

10. To prepare the CMA's connector D for installation, remove the tape that secures the slide-rail latching bracket to connector D and ensure that the latching bracket is properly aligned with connector D (frames 1 and 2).

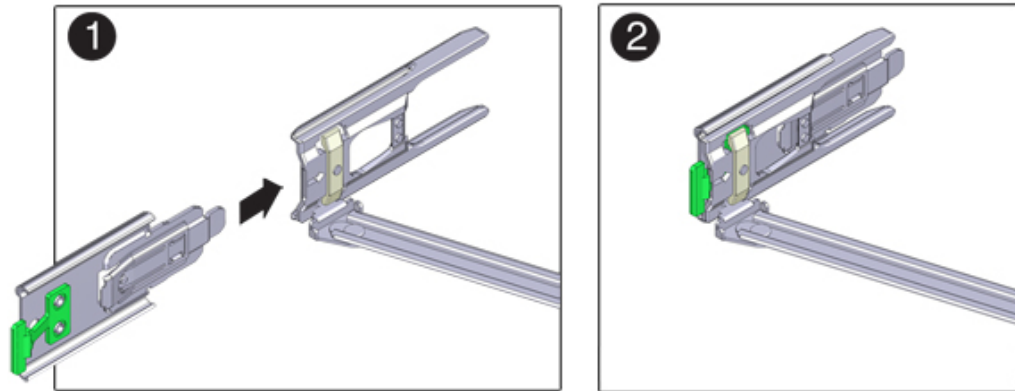

11. While holding the slide-rail latching bracket in place, insert connector D and its associated slide-rail latching bracket into the left slide-rail until connector D locks into place with an audible click (frames 1 and 2).

When inserting connector D into the slide-rail, the preferred and easier method is to install connector D and the latching bracket as one assembly into the slide-rail.

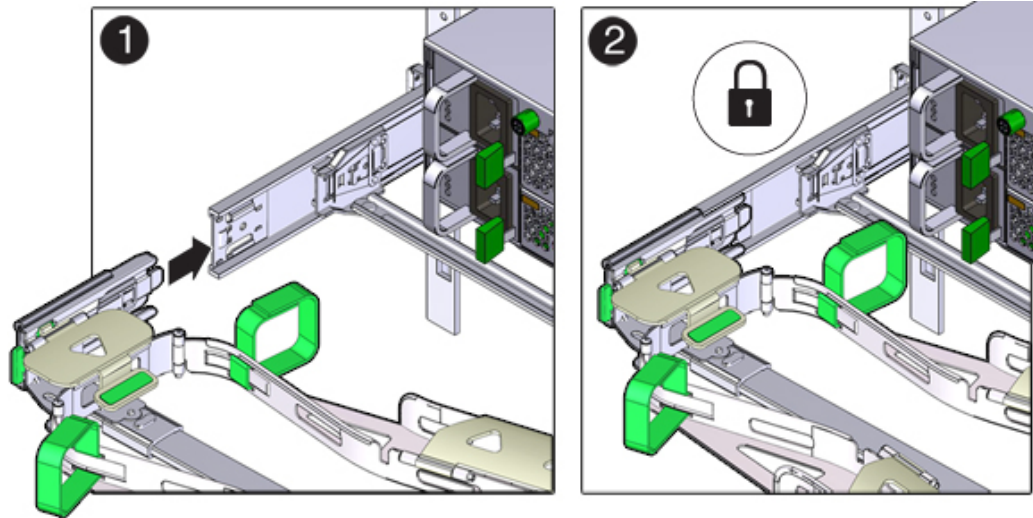

12. Gently tug on the left side of the CMA's rear slide bar to verify that connector D is properly seated.
13. Gently tug on the four CMA connection points to ensure that the CMA connectors are fully seated before you allow the CMA to hang by its own weight.
14. Verify that the slide-rails and the CMA are operating properly before routing cables through the CMA:
 - a. Ensure all rack anti-tilt devices are extended to prevent the rack from tipping.

- b. **Extend the controller from the front of the rack until the CMA is fully extended.**

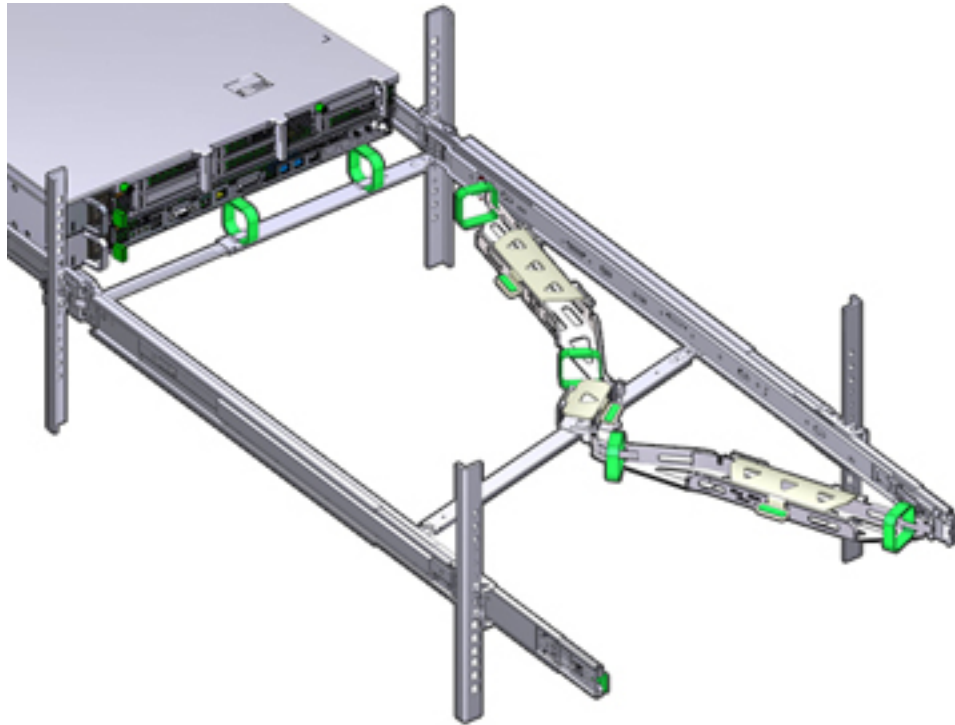

15. **Return the storage controller to the rack. As you push the storage controller into the rack, verify that the CMA retracts without binding.**
16. **Open the CMA cable covers, route controller cables through the CMA's cable troughs, close the cable covers, and secure the cables with the six Velcro straps. Route the cables through the cable troughs in this order: Route the cables**

through the front-most cable trough, then through the small cable trough, then through the rear-most cable trough.

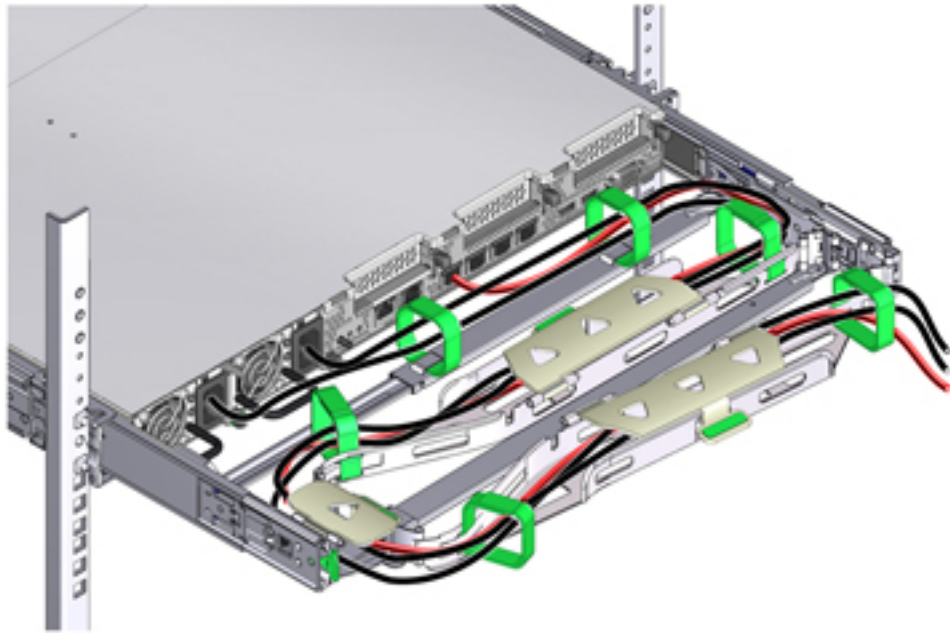

- 17. When securing the cables with the Velcro straps located on the front slide bar, ensure that the Velcro straps do not wrap around the bottom of the slide bar.**
Otherwise, expansion and contraction of the slide bar might be hindered when the server is extended from the rack and returned to the rack.
- 18. Ensure that the secured cables do not extend above the top or below the bottom of the server to which they are attached.**
Otherwise, the cables might snag on other equipment installed in the rack when the server is extended from the rack or returned to the rack.
- 19. If necessary, bundle the cables with additional Velcro straps to ensure that they stay clear of other equipment.**
If you need to install additional Velcro straps, wrap the straps around the cables only, not around any of the CMA components; otherwise, expansion and contraction of the CMA slide bars might be hindered when the server is extended from the rack and returned to the rack.

▼ Verifying Operation of ZS3-2 Slide-Rails and CMA

Use the following procedure to verify the operation of the optional CMA and slide rails on a ZS3-2 controller.

Before You Begin Ensure all rack anti-tilt devices are extended to prevent the rack from tipping forward when the storage controller is extended from the rack.

1. **Slowly pull the storage controller out of the rack until the slide-rails reach their stops.**
2. **Inspect the attached cables for any binding or kinks.**
3. **Verify that the CMA extends fully with the slide-rails.**
4. **Push the storage controller back into the rack and verify that the CMA retracts without binding.**
5. **Adjust the cable straps and the CMA, as required.**

Installing a 7x20 Controller

This section contains installation procedures for the 7420, 7320, and 7120 controllers.

Before beginning installation, see [“Installation Prerequisites and Hardware Overviews”](#) on page 13.

Use the following procedures to install a 7x20 controller:

- [“Removing the 7x20 Mounting Brackets from inside the Slide Rails”](#) on page 179
- [“Installing the Mounting Brackets on a 7x20”](#) on page 181
- [“Installing a 7x20 onto the Rack Slide Rails”](#) on page 183
- [“Installing a 7x20 Cable Management Arm”](#) on page 188

▼ Removing the 7x20 Mounting Brackets from inside the Slide Rails

Use this procedure to remove the 7x20 mounting brackets from inside the slide rails. If the mounting brackets were not shipped inside the slide rails, move on to [“Installing the Mounting Brackets on a 7x20”](#) on page 181.

1. **Unpack the slide rails and locate the slide rail lock at the front of the assembly.**
2. **Squeeze and hold the tabs at top and bottom of the lock (1) while you pull the mounting bracket out to the stop.**
3. **Push the mounting bracket release button toward the front of the mounting bracket (2) while withdrawing the bracket from the assembly.**

Example 1 Disassembling a 7120/7320 Rail Kit

The following graphic illustrates the procedure for disassembling the 7120/7320 rail kit.

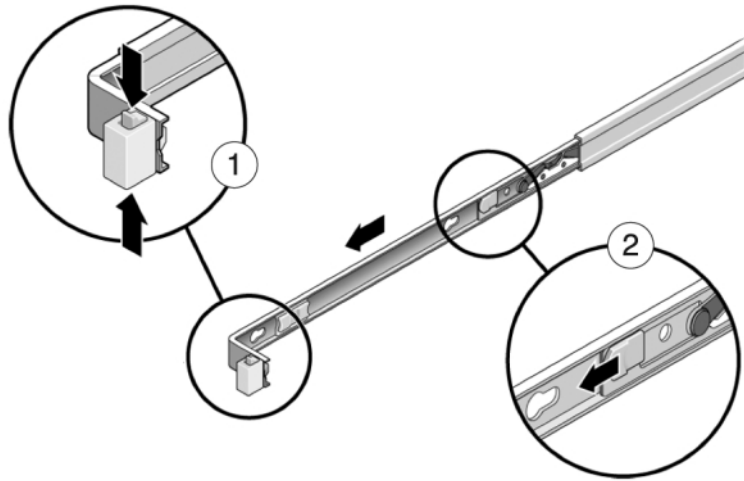

Example 2 Disassembling a 7420 Rail Kit

The following graphic illustrates the procedure for disassembling the 7420 rail kit.

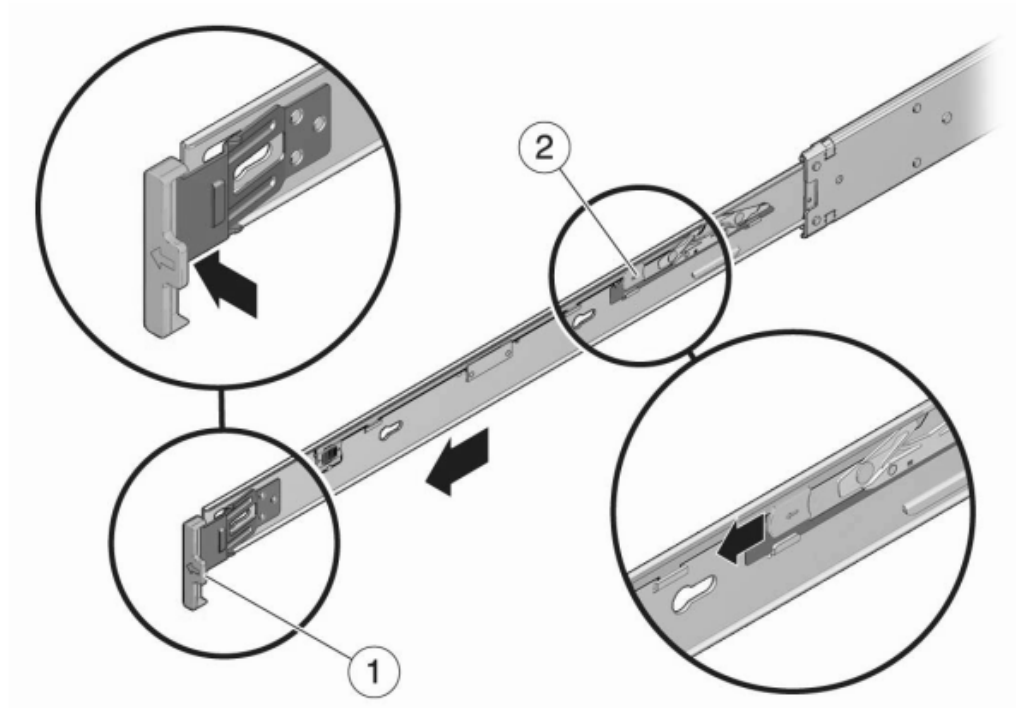

▼ Installing the Mounting Brackets on a 7x20

Use the following procedure to install the mounting brackets on a 7420, 7320, or 7120 controller.

Note - If the mounting brackets are shipped inside the slide rails, you must remove them before beginning this procedure; see [“Removing the 7x20 Mounting Brackets from inside the Slide Rails”](#) on page 179.

1. **Position a mounting bracket against the chassis so that the slide rail lock is at the front of the chassis, and the keyhole openings on the mounting bracket are aligned with the locating pins on the side of the chassis.**

The following graphic illustrates how to attach the 7120/7320 mounting brackets.

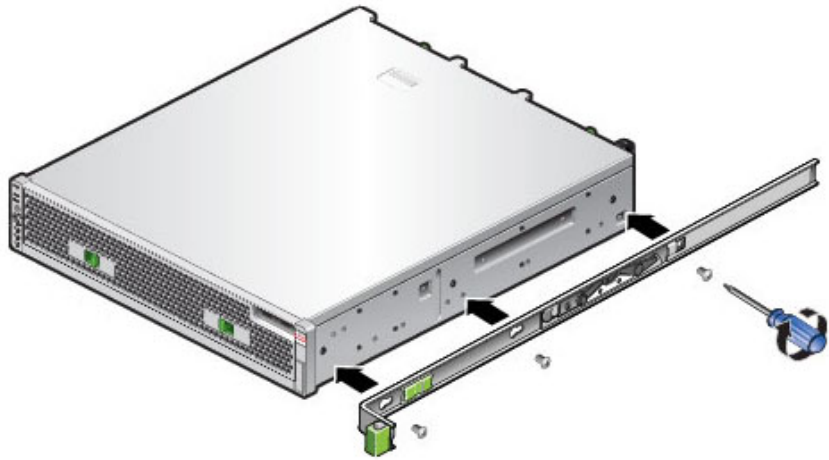

2. The following graphic illustrates how to attach the 7x20 mounting brackets.

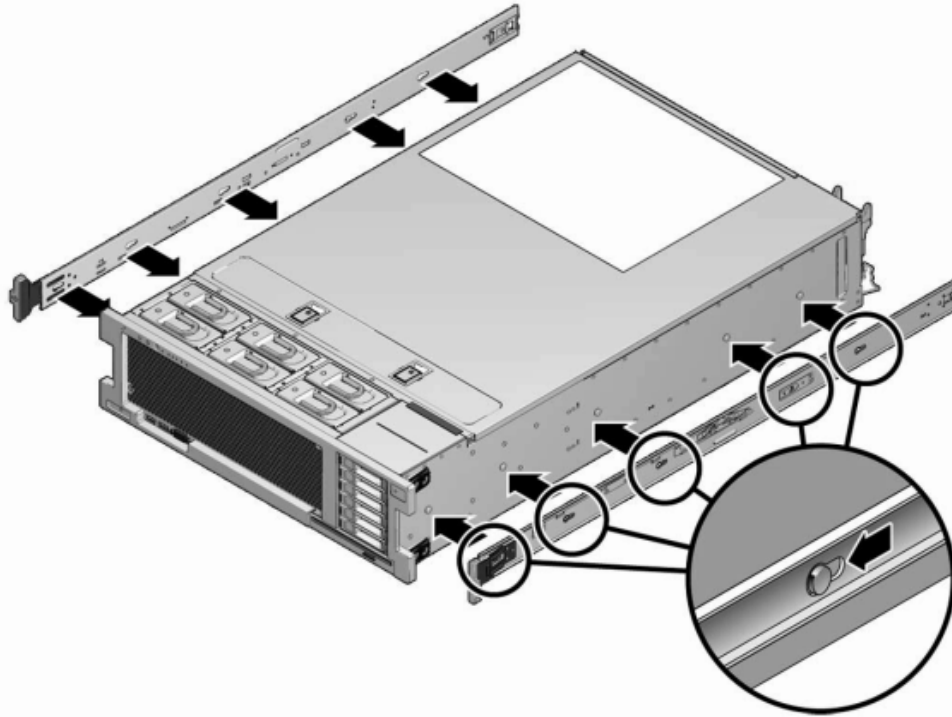

3. With the heads of the four chassis locating pins protruding through the four keyhole openings in the mounting bracket, pull the mounting-bracket toward the front of the chassis until the mounting-bracket clip locks into place with an audible click.
4. Verify that all mounting pins are securely fastened to the chassis.
5. Repeat to install the remaining mounting bracket on the other side of the chassis.

▼ Installing a 7x20 onto the Rack Slide Rails

Use the following procedure to install a 7420, 7320, or 7120 controller onto the rack slide rails.



Caution - This procedure requires a minimum of two people because of the weight of the chassis. Attempting this procedure alone could result in equipment damage or personal injury. Always load equipment into rack from the bottom up.

Before You Begin Extend all anti-tilt and stabilization devices from the bottom of the rack.

1. **If you are using a universal 19-inch cabinet, snap an M6 square cage nut into the top and bottom holes of the location where you will be installing the rail plate as shown.**

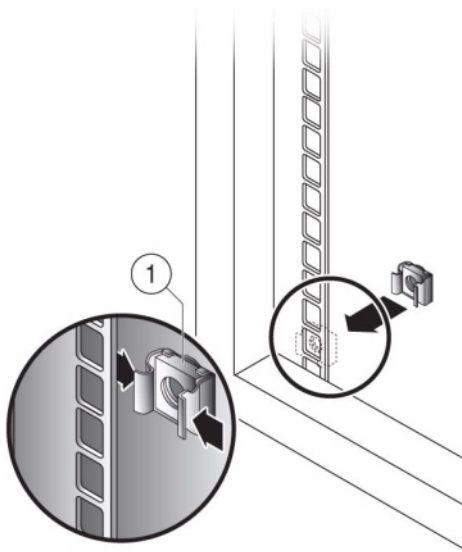

2. **Position a slide rail assembly in your rack so that the brackets at each end of the slide rail assembly are on the outside of the front and back rack posts.**

The following graphic illustrates the rail assembly brackets.

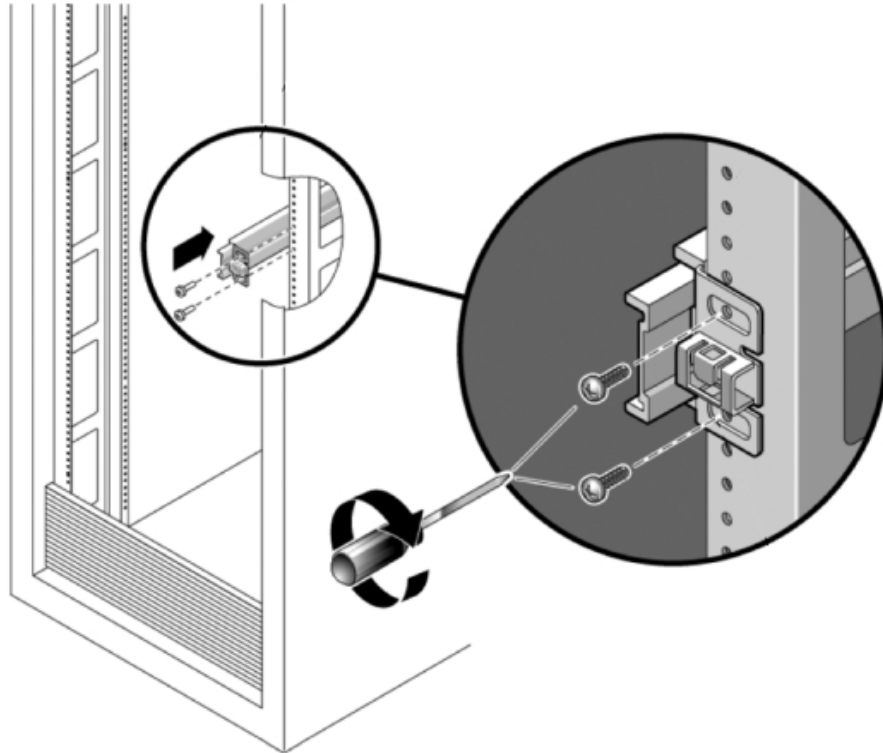

3. **Attach each slide rail assembly to the rack posts, but do not tighten the screws completely.**

4. **From the front of the rack, set the proper width of the rails with the rail-width spacer (1).**

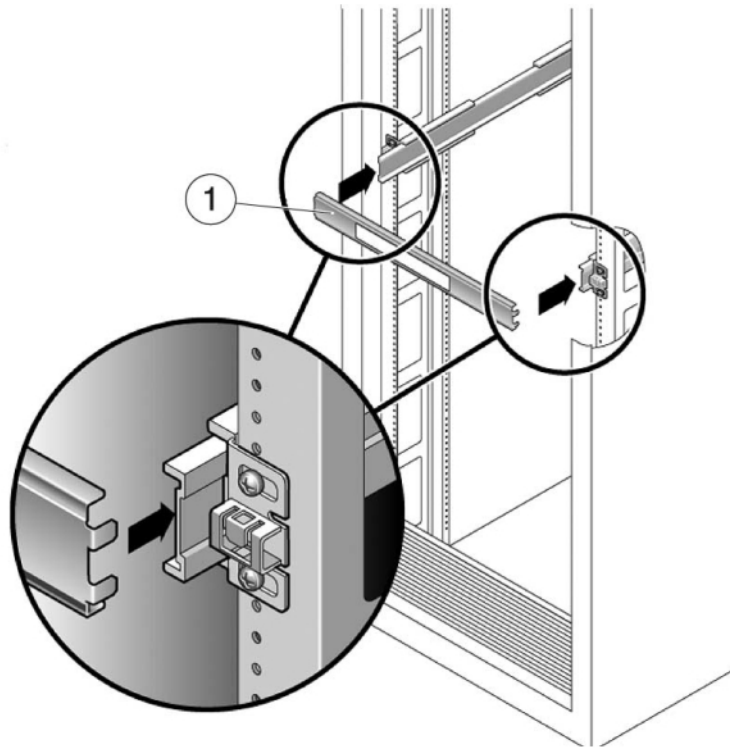

5. **Tighten the screws on the brackets.**
6. **Remove the spacer and confirm that the rails are attached tightly to the rack.**
7. **Lower the rack stabilization and anti-tilt devices if you have not already done so.**
8. **Push the slide rails into the slide rail assemblies in the rack as far as possible.**
9. **Raise the chassis so that the back ends of the mounting brackets are aligned with the slide rail and insert the chassis into the slide rails, pushing the chassis slowly, until the mounting brackets meet the slide rail stops (~12 in or 30 cm).**
You will hear an audible click.

Example 3 Installing a 7120/7320 onto the Rack Slide Rails

The following graphic illustrates the 7120/7320 chassis insertion and slide rail locks usage.

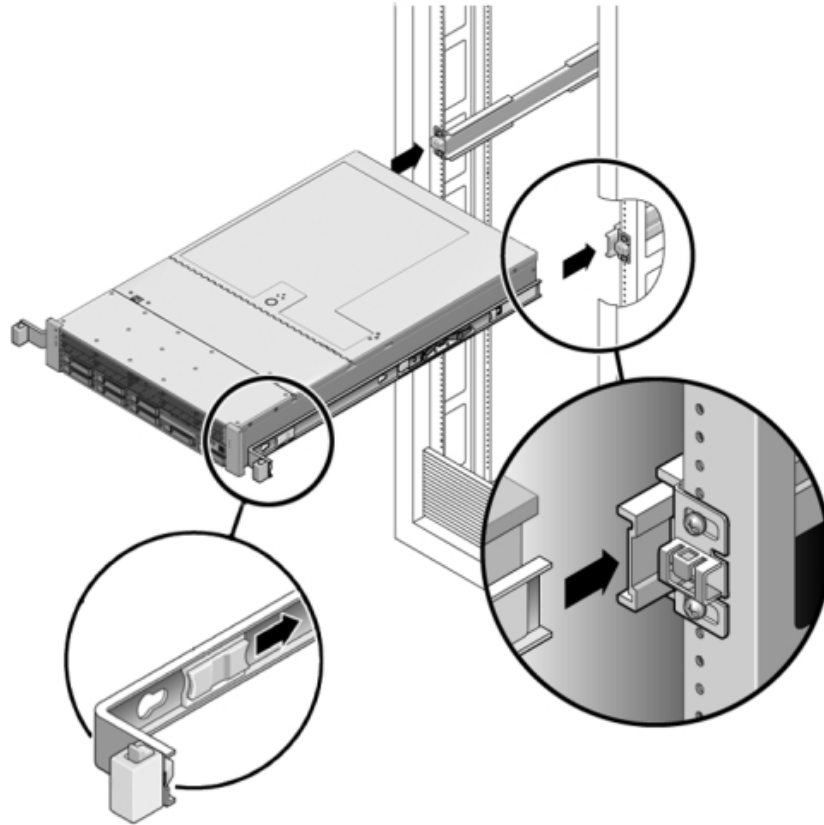

Example 4 Installing a 7420 onto the Rack Slide Rails

The following graphic illustrates 7420 chassis insertion.

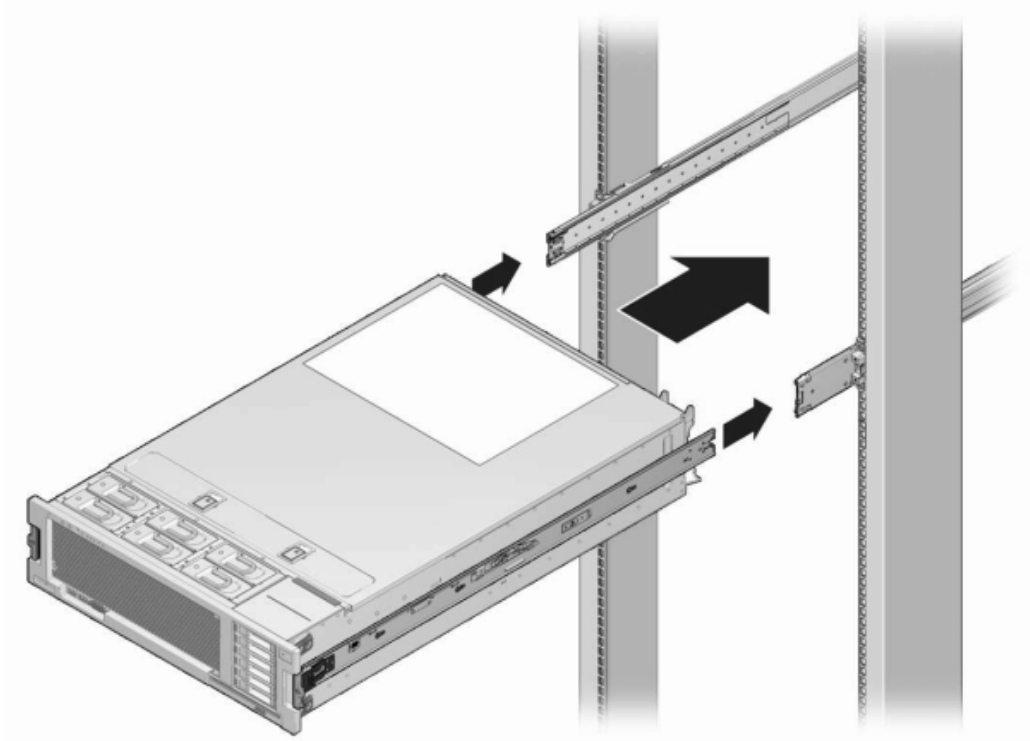

▼ Installing a 7x20 Cable Management Arm

Use the following procedure to install the optional cable management arm (CMA) for a 7x20 controller.

This procedure is completed from the back of the equipment rack.

Before You Begin Unpack the CMA and identify its components.

To prepare for installing the optional cable management arm (CMA), follow these guidelines:

- Route cluster cables, long-term host cables (including InfiniBand, Fibre Channel, and Ethernet Cables) and up to 12 disk shelf SAS cables through the CMA.
- Do not route short SAS daisy chain cables through the CMA. Do not route an excess of cables such that the CMA clamps bow or appear structurally unfit to support the weight.

- If using two clustered controllers mounted in the middle of the rack with disk shelves located above and below them, you can divide the disk shelf SAS cables between the two CMAs so they properly route to the upper and lower disk shelves.
 - If later removing the CMA, be sure to support it as you remove the connectors.
1. **Attach the CMA rail extension to the left slide rail until the extension locks into place.**

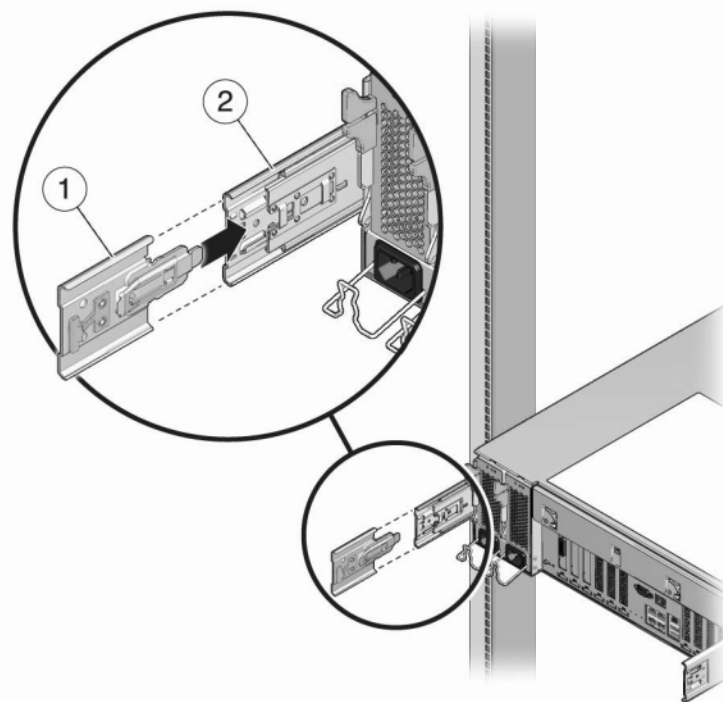

2. Insert the CMA mounting bracket connector into the right slide rail until the connector locks into place.

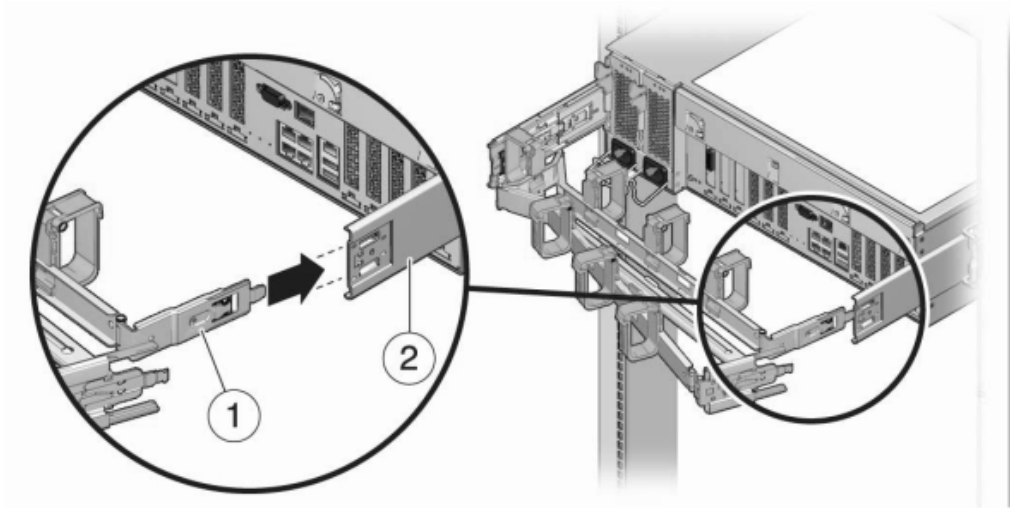

3. Insert the right CMA slide rail connector (1) into the right slide rail assembly (2) until the connector locks into place.

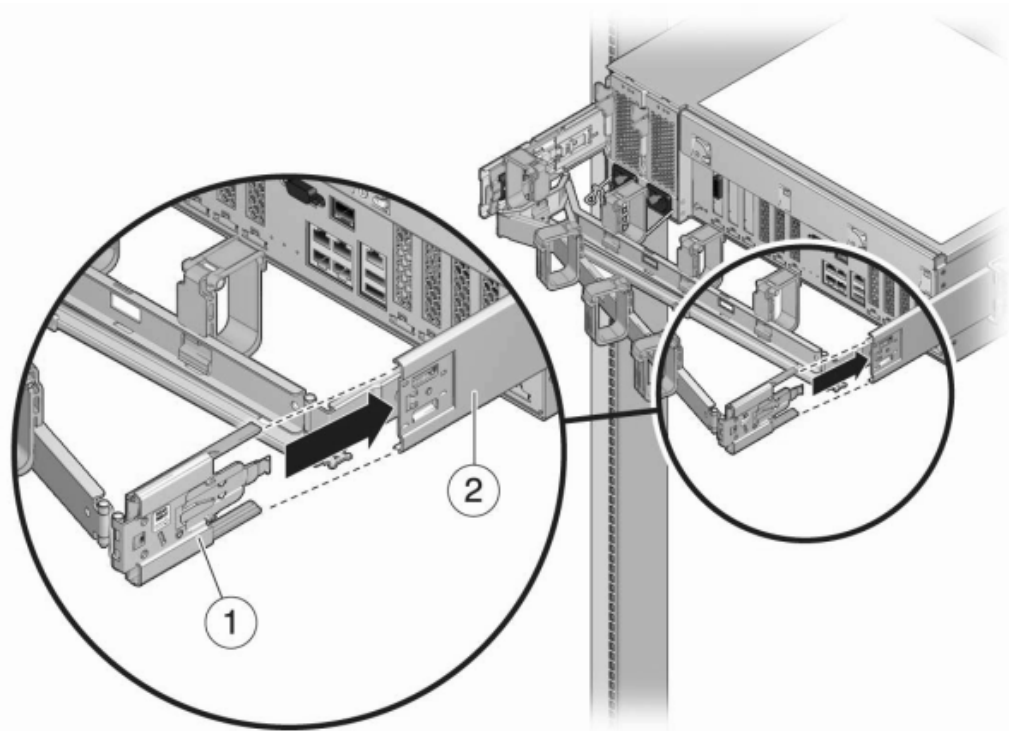

4. Insert the left CMA slide rail connector (1) into the rail extension on the left slide rail assembly (2) until the connector locks into place.

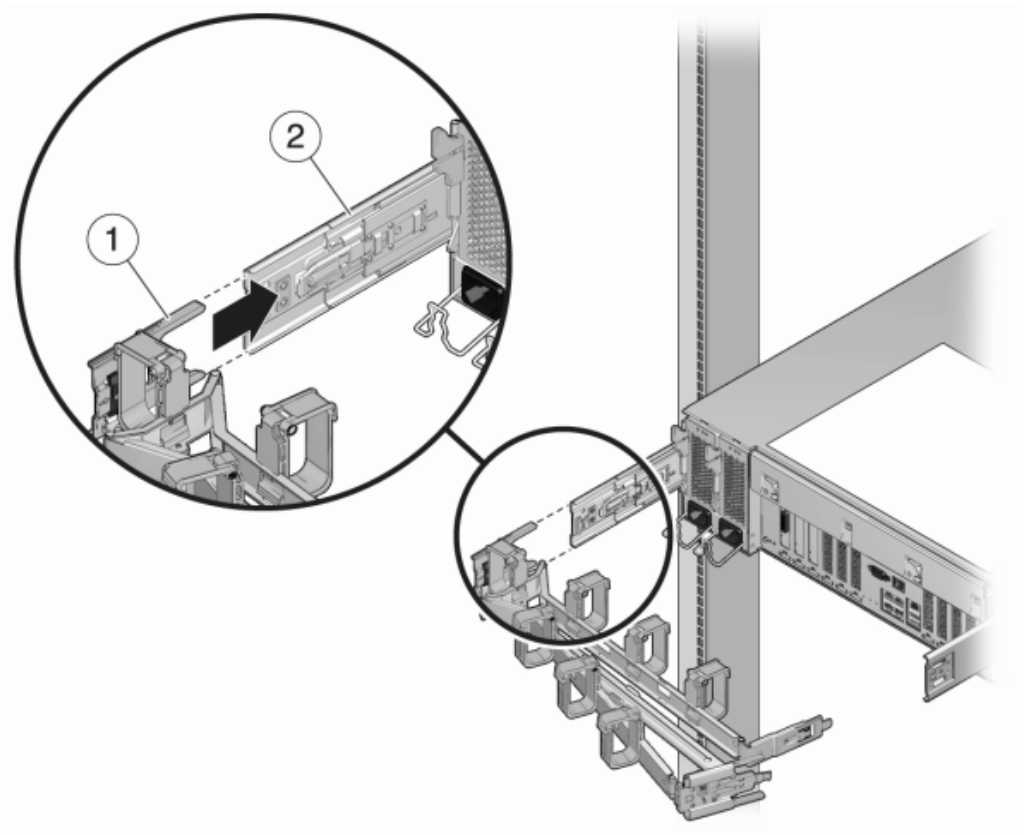

5. After you install and route the cables through the assembly, attach the hook and loop straps (1) to secure the cables. Then attach the right and left outer latches to support the assembly.

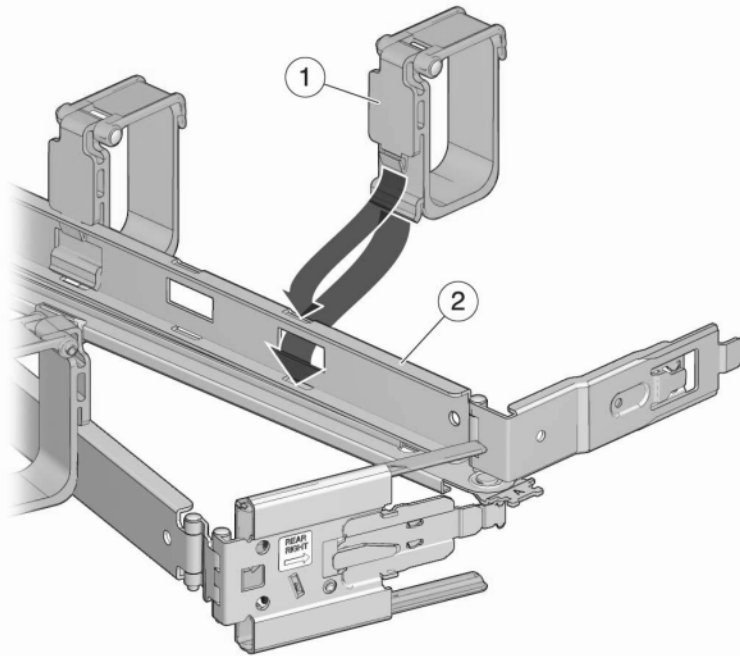

Cabling the Appliance

This section contains cabling procedures for appliance installation, including connections to the controller service processor (SP) and network, cluster cabling, as well as cabling between disk shelves and controllers.

Use the following procedures to cable the appliance:

- [“Connecting System Cables” on page 195](#)
- [“Connecting Cluster Cables” on page 196](#)
- [“Connecting Disk Shelf Cables” on page 200](#)

For cabling and cabinet guidelines, see [“Cabinet Configuration Guidelines” on page 17](#). For a wide range of specific cabling configurations, refer to [“Getting Started with Cabling” in *Oracle ZFS Storage Appliance Cabling Guide*](#).

▼ Connecting System Cables

Use the following procedure to make a physical serial or network connection to Oracle ILOM.

It is strongly recommended that you use a serial SP connection for system configuration and initial configuration because you can monitor progress, especially during system reboots. Afterwards, it is recommended that you remove the serial connection if you do not need it for CLI access. Instead, make a network SP connection, which allows for better collection of platform data.



Caution - Failure to configure Oracle ILOM connectivity after initial setup may lead to longer than necessary hardware fault diagnosis and resolution times. For more information about Oracle ILOM, see [“Using Oracle ILOM to Diagnose Hardware Faults” in *Oracle ZFS Storage Appliance Cabling Guide*](#).

Before You Begin Ensure the storage controllers and disk shelves are installed, but not cabled together.

If making a serial connection to the SP (recommended), ensure that you have configured the administrative client as described in [“Configuring the System” on page 210](#).

To make a network connection to the SP, your network must have a DHCP server.



Caution - Do not connect the power cables until instructed to do so in [“Powering On the Appliance” on page 203](#).

1. **To prepare for system configuration, perform one of the following SP connections:**
 - For a serial SP connection (recommended), attach a serial cable from the SER MGT port on the rear panel of the controller to the serial port on the administrative client. Use a DB9 to RJ45 adapter if necessary.
 - For a network SP connection, attach an Ethernet cable from the NET MGT port on the rear panel of the controller to your Ethernet switch.

If clustered controllers, repeat for the second controller.

2. **Connect an Ethernet cable from the NET-0 port on the rear panel of the controller to your Ethernet switch.**

If clustered controllers, repeat for the second controller.

▼ Connecting Cluster Cables

The cluster interface card provides three redundant links that enable two controllers to communicate with each other. The cluster I/O ports consist of two serial links (0,1) and an Ethernet link. Cluster cabling must be done before powering on either controller, and all three links must be established before configuration can proceed.

Before You Begin Gather the three Ethernet cables that were supplied for connecting clustered controllers. The ZS7-2 and ZS5-x cluster cables are 2.5-meters in length. Cluster cables on other controllers are 1-meter in length. If supplying your own Ethernet cables, ensure they are straight-through, Category 5 or better, and the correct length.

1. **Connect the cluster serial ports of each controller to form a crossover pattern:**
 - a. **Connect one Ethernet cable between serial port 0 of one controller and serial port 1 of the other controller.**
 - b. **Connect another Ethernet cable between serial port 1 of one controller and serial port 0 of the other controller.**

The cables between the serial ports form a crossover pattern, as shown in the following illustrations. For ZS7-2 controllers, use the supplied yellow and green Ethernet cables. Use one cable for step 1a and the other for step 1b; it does not matter which cable you use.

2. Connect one Ethernet cable between the Ethernet ports of each controller.

The following figure shows cluster cabling between two ZS7-2 controllers (high-end model shown). Use the supplied black Ethernet cable.

ZS7-2 Cluster Cabling

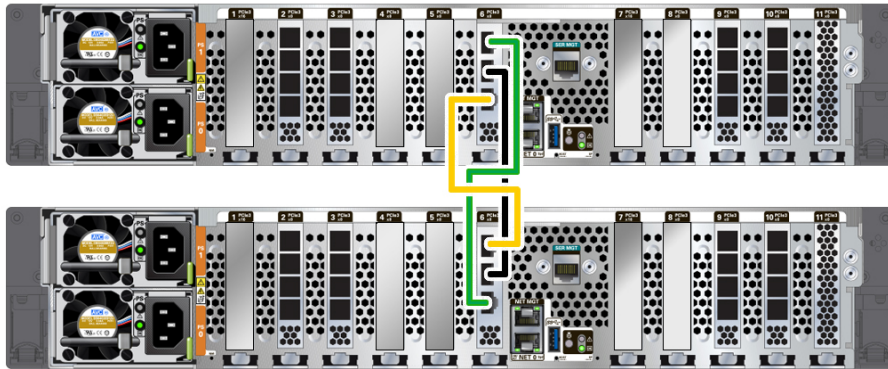

The following figure shows cluster cabling between two ZS5-4 controllers.

ZS5-4 Cluster Cabling

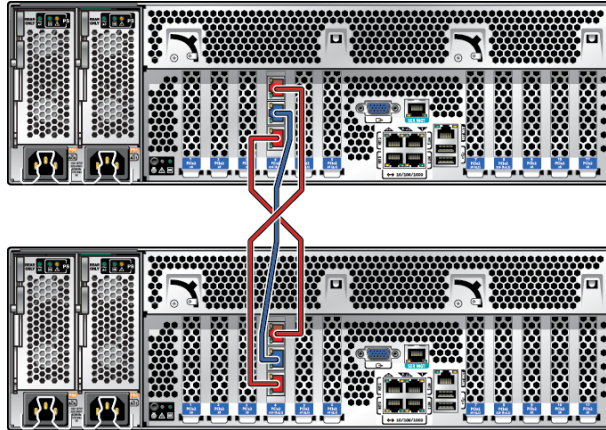

The following figure shows cluster cabling between two ZS5-2 controllers.

ZS5-2 Cluster Cabling

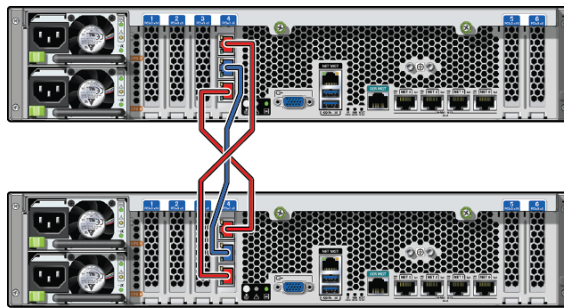

The following figure shows cluster cabling between two ZS4-4 controllers.

ZS4-4, ZS3-4, 7420 Cluster Cabling

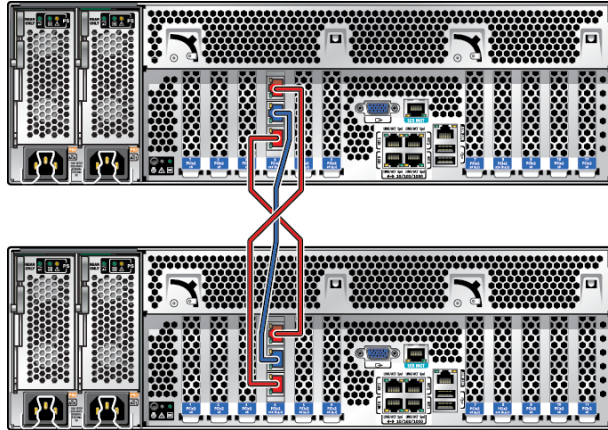

Note - The cluster card for ZS3-4 and 7420 is installed in the Cluster slot, as described in the hardware overview for each controller in [Oracle ZFS Storage Appliance Customer Service Manual](#).

The following figure shows cluster cabling between two ZS3-2 controllers.

ZS3-2 Cluster Cabling

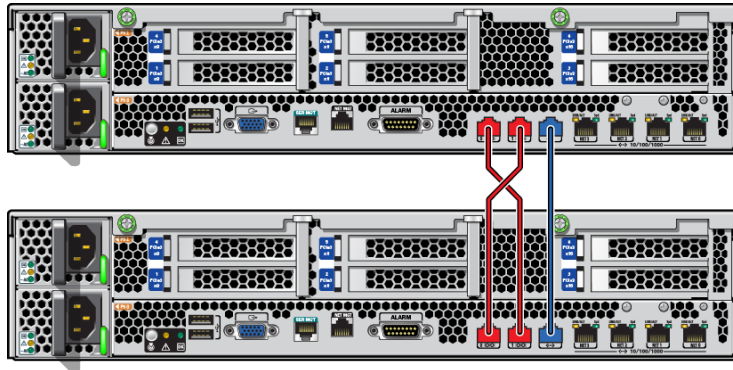

▼ Connecting Disk Shelf Cables

Use the following procedure to connect the cables between storage controller(s) and disk shelves.



Caution - Do not connect the power cables until instructed to do so in [“Powering On the Appliance” on page 203](#).

The cabling configuration for your appliance depends on the number and type of controllers and disk shelves, as well as the number of host bus adapters (HBAs) in your system. Disk shelves attach to other disk shelves with daisy-chained serial attached SCSI (SAS) cables. Controllers attach to each disk shelf chain with a longer SAS cable connected via HBAs located in specified PCIe slots of the controllers. Clustered controllers are attached via three Ethernet cables that provide redundant communication channels: two serial links and an Ethernet link. The cabling methodology designed for the appliance includes bottom-to-top cabling for easier growth with optimum safety, strategic slot placement for optimum load distribution and performance, and interface redundancy for clustered controllers, ensuring no single point of failure.

1. **Locate the appropriate cabling configuration for your system in [“Getting Started with Cabling” in Oracle ZFS Storage Appliance Cabling Guide](#).**
 - [“Cabling DE3-24 Disk Shelves to 4X4 Port SAS-3 HBAs” in Oracle ZFS Storage Appliance Cabling Guide](#)
 - [“Cabling DE2-24 Disk Shelves to 4X4 Port SAS-2 HBAs” in Oracle ZFS Storage Appliance Cabling Guide](#)
 - [“Cabling DE2-24 Disk Shelves to 2X4 Port SAS-2 HBAs” in Oracle ZFS Storage Appliance Cabling Guide](#)
 - [“Cabling Sun Disk Shelves” in Oracle ZFS Storage Appliance Cabling Guide](#)
 - [“Cabling Mixed DE3-24 and DE2-24 Disk Shelves” in Oracle ZFS Storage Appliance Cabling Guide](#)
 - [“Cabling Mixed DE2-24 and Sun Disk Shelves” in Oracle ZFS Storage Appliance Cabling Guide](#)
2. **Connect cables between disk shelves and between storage controller(s) and disk shelves.**

If clustered controllers, be sure to connect the cluster cables as described in [“Connecting Cluster Cables” on page 196](#).

Example 5 Disk Shelf Cabling Example

The following illustration shows the cable connections for two clustered Oracle ZFS Storage ZS4-4 controllers and eight DE2-24C disk shelves. The controllers, as recommended, are located in the middle of the cabinet.

For cabling diagrams of specific configurations, refer to [“Getting Started with Cabling” in Oracle ZFS Storage Appliance Cabling Guide](#).

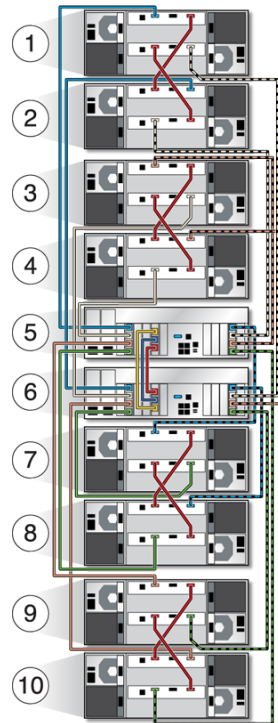

Callout	Description	Callout	Description
1	Shelf 8 (RU 35-38)	6	Controller 2 (RU 17-19)
2	Shelf 7 (RU 31-34)	7	Shelf 4 (RU 13-16)
3	Shelf 6 (RU 27-30)	8	Shelf 3 (RU 9-12)
4	Shelf 5 (RU 23-26)	9	Shelf 2 (RU 5-8)
5	Controller 1 (RU 20-22)	10	Shelf 1 (RU 1-4)

Powering On the Appliance

This section contains power-on procedures for Oracle ZFS Storage Appliance disk shelves and storage controllers.



Caution - Do not power on disk shelves and controllers until all other cabling is complete, as described in [“Cabling the Appliance” on page 195](#).

Follow these steps to power on the appliance:

1. Power on disk shelves using the appropriate procedure:
 - [“Powering On a DE3-24 or DE2-24 Disk Shelf” on page 203](#)
 - [“Powering On a Sun Disk Shelf” on page 205](#)
2. Power on controllers. See [“Powering On a Controller” on page 205](#).

Use the following procedures to power off the appliance:

- [“Powering Off a Disk Shelf” on page 207](#)
- [“Powering Off a Controller” on page 206](#)

▼ Powering On a DE3-24 or DE2-24 Disk Shelf

Use the following procedure to power on a DE3-24P, DE3-24C, DE2-24P or DE2-24C disk shelf.

Before You Begin Ensure you have met the following electrical safety measures before applying power to the disk shelf:

- Provide a suitable power source with electrical overload protection to meet the power supply input voltage range of 100-240 VAC, 50-60 Hz. The disk shelves are compatible with 100-120 VAC or 200-240 VAC sources. The power source must not be overloaded by the total number of disk shelves in the cabinet. At full load, each DE3-24 or DE2-24 draws 707.8W.
- The power source must provide a reliable earth connection for each disk shelf and the cabinet.

- Ensure that the power source is easily accessible because the power cord is the main disconnect device for the disk shelf.

1. **Plug a power cord into each power supply with fan module.**
2. **Plug the other end of the power cords into the external power source for the cabinet.**

Note - To guarantee redundancy, power cords must be connected to two separate and independent power sources.

3. **Supply power to the external power source.**
4. **Place the power supply on/off switches to the "I" on position.**
5. **Turn on the cabinet circuit breakers, if applicable.**
6. **After the disk shelf powers on, which could take several minutes, ensure that the system power indicator on the front of the disk shelf is lit a steady green, and that each power supply with fan module status indicator on the rear is lit a steady green.**

If not, reseal the faulted module after powering off the disk shelf as described in [“Powering Off a Disk Shelf” on page 207](#). If the module status indicator is not a steady green after module reinsertion and powering on, contact Oracle Customer Service.



Related Topics

- [“Powering Off a Disk Shelf” on page 207](#)

- [“Powering Off a Controller” on page 206](#)

▼ Powering On a Sun Disk Shelf

Use the following procedure to power on a Sun Disk Shelf.

Before You Begin Ensure you have met the following electrical safety measures before applying power to the disk shelf:

- Provide a suitable power source with electrical overload protection to meet the power supply input voltage range of 100-240 VAC, 50-60 Hz. The disk shelves are compatible with 100-120 VAC or 200-240 VAC sources. The power source must not be overloaded by the total number of disk shelves in the cabinet. At full load, each Sun Disk Shelf draws 912W.
 - The power source must provide a reliable earth connection for each disk shelf and the cabinet.
 - The power source must be easily accessible because the power cord is the main disconnect device for the disk shelf.
1. **Plug the two power cords into the universal power connectors.**
 2. **Connect the cords to the external power source.**
 3. **Turn on the disk shelf power switches.**
 4. **Wait several minutes until the power indicators are lit a steady green.**

Related Topics

- [“Powering Off a Disk Shelf” on page 207](#)
- [“Powering Off a Controller” on page 206](#)

▼ Powering On a Controller

Use the following procedure to power on an Oracle ZFS Storage Appliance controller.

1. **Plug power cables into power supply 0 and power supply 1 on the storage controller(s).**
2. **Connect cables to the external power source.**

The controller automatically powers on.

3. **Wait until the Power/OK LED on the front panel next to the Power button lights and remains lit (approximately two minutes).**

If the Service Required amber indicator is lit, see [“Using Oracle ILOM to Diagnose Hardware Faults”](#) in *Oracle ZFS Storage Appliance Customer Service Manual*. Also see the Oracle ILOM documentation located in the documentation library for this software release at <http://docs.oracle.com/en/storage/>.

Related Topics

- [“Powering Off a Controller”](#) on page 206

Powering Off a Controller

The recommended methods for powering off a controller depend on whether you have completed initial configuration. Use a power off method from one of the following two situations.

If you have completed initial configuration, power off the controller using one of the following methods:

- Log in to the BUI and click the power icon  on the left side under the masthead.
- SSH in to the appliance and enter the `maintenance system poweroff` command.
- Use a pen or non-conducting pointed object to press and release the Power button on the front panel.

If you have not completed the initial configuration steps, power off the controller using one of the following methods:

- Use a pen or non-conducting pointed object to press and release the Power button on the front panel.
- SSH or use a serial connection to log in to the service processor (SP), and then issue the command `stop /SYS`.
- To initiate an emergency shutdown during which all applications and files will be closed abruptly without saving, press and hold the Power button for at least four seconds until the Power/OK status indicator on the front panel flashes, indicating that the storage controller is in standby power mode. To completely remove power, disconnect the AC power cords from the rear panel of the storage controller.

Related Topics

- [“Powering Off a Disk Shelf” on page 207](#)
- [“Powering On a Controller” on page 205](#)

▼ Powering Off a Disk Shelf

If a disk shelf is a part of a storage pool, powering off or removing all SAS chains from a disk shelf will trigger a kernel panic on the controller(s) to prevent data loss, unless the shelf is part of an NSPF (no single point of failure) data pool. To avoid this, shut down the controller(s) before decommissioning the shelf, as described in [“Powering Off a Controller” on page 206](#).

1. **Place the power supply on/off switches to the "O" off position.**
2. **Disconnect the power cords from the external power source for the cabinet.**

Note - All power cords must be disconnected to completely remove power from the disk shelf.

Related Topics

- [“Powering Off a Controller” on page 206](#)
- [“Powering On a DE3-24 or DE2-24 Disk Shelf” on page 203](#)
- [“Powering On a Sun Disk Shelf” on page 205](#)

Configuring the Appliance for the First Time

This section contains first-time configuration procedures for the Oracle ZFS Storage Appliance.

Follow these steps to complete first-time configuration:

1. Ensure you have completed cabling, including the serial or network cabling for Oracle ILOM connectivity, as described in [“Cabling the Appliance” on page 195](#).
2. Configure the system through Oracle ILOM. See [“Configuring the System” on page 210](#).

Note - After system configuration, a network device and its associated datalink and interface are automatically created with administrative access. You can add interfaces, and add or change administrative access to other interfaces during and after initial configuration.

3. Complete initial configuration using the browser user interface (BUI), which is strongly recommended for clustered controllers, or the command line interface (CLI):
 - [“Performing Initial Configuration \(BUI\)” on page 213](#)
 - [“Performing Initial Configuration \(CLI\)” on page 227](#)

For an overview of network interface configuration, see [“Working with Network Configuration” in Oracle ZFS Storage Appliance Administration Guide, Release OS8.8.0](#).

4. If you did not set a management interface during initial configuration, set it now using the tasks in [“Configuring Management Interfaces” in Oracle ZFS Storage Appliance Administration Guide, Release OS8.8.0](#).
5. For clustered controllers, lock the management interfaces:
 - [“Locking Cluster Management Interfaces \(BUI\)” in Oracle ZFS Storage Appliance Administration Guide, Release OS8.8.0](#)
 - [“Locking Cluster Management Interfaces \(CLI\)” in Oracle ZFS Storage Appliance Administration Guide, Release OS8.8.0](#)
6. Upgrade your controller software to the latest release using the procedures in [“Upgrading the Software” in Oracle ZFS Storage Appliance Customer Service Manual](#).

▼ Configuring the System

Use this procedure to configure the system through Oracle Integrated Lights Out Manager (ILOM) when the appliance is first powered on.

Oracle ILOM, which is pre-installed in all storage controllers, is a service processor (SP) with an embedded operating system. It provides a full-featured, browser-based web interface and has an equivalent command line interface (CLI). Therefore, you can connect to Oracle ILOM through a serial connection or through a network connection if your network has a Dynamic Host Configuration Protocol (DHCP) server.

A serial SP connection is recommended for initial configuration because Oracle ILOM has no initial network connectivity. This connection lets you monitor progress, especially during system reboots. Afterwards, you can remove the serial connection if you do not need it for CLI access. Instead, make a network SP connection, which allows for better collection of platform data, as described in [“Troubleshooting Hardware Faults” on page 237](#).

By keeping an Oracle ILOM connection in place after configuration, you can troubleshoot hardware problems that do not otherwise appear in the appliance software, as well as update the BIOS. Failure to configure Oracle ILOM connectivity may lead to longer than necessary hardware fault diagnosis and resolution times.

- Before You Begin**
- If using a serial connection to the appliance, configure an administrative client with the following settings:
 - 8N1: eight data bits, no parity, one stop bit
 - 9600 baud
 - Disable hardware flow control (CTS/RTS)
 - Disable software flow control (XON/XOFF)
 - Ensure you have completed cabling, including the serial or network cabling for Oracle ILOM connectivity, as described in [“Cabling the Appliance” on page 195](#).
 - For clustered controllers, perform this procedure on only one controller, the primary controller. The software propagates the configuration to the peer controller during cluster initialization. It does not matter which controller you choose as the primary controller. After the cluster is initialized, you can administer the system from either storage controller. However, do not attempt initial configuration on both controllers independently.
1. **Open a terminal or terminal emulator window and log in to Oracle ILOM in one of the following ways:**
 - For a serial connection (recommended), use `root` as the user name. Enter the name of the serial port concentrator, such as `telnet`, followed by `serial-concentrator portnumber`. Use the appropriate value for `portnumber`. For example: `telnet serial-concentrator 100`

- For a network connection, use a Secure Shell (SSH) session and enter **root** as the user name. Determine the IP address by accessing your DHCP server for the address assigned to the service processor MAC address (see the label on the storage controller). For example: `ssh root@192.168.128.256`

2. When prompted, enter the password `changeme`.

Note - This is the default password that provides initial access to Oracle ILOM. You can set a different password for the appliance in step 5.

3. At the command prompt, enter `start /SP/console`.

4. To confirm that you want to start the console, enter `y`.

Text similar to the following is shown on the console:

```
SunOS Release 5.11 Version ak/generic@2013.06.05.0.0,1-1.6 64-bit
Copyright (c) 1983, 2013, Oracle and/or its affiliates. All rights reserved.
System configuration in progress.
Configuring version: ak/nas@2013.06.05.0.0,1-1.6
```

```
Creating active datasets ..... done.
Starting primordial svc.configd
SMF online in 2 seconds
Loading smf(5) service descriptions: 165/165
svccfg: Loaded 165 smf(5) service descriptions
Loading smf(5) service descriptions: 24/24
Applying profile install/akinstall.xml ... done.
Applying service layer generic ... done.
Applying service layer nas ... done.
Applying service layer SUNW,iwashi_plus ... done.
Applying service profile generic ... done.
Enabling auditing of Solaris commands ... done.
Shutting down svc.configd ... done.
Configuring devices.
Configuring network devices.
```

```
Sun ZFS Storage 7120 Version ak/SUNW,iwashi_plus@2013.06.05.0.0,1-1.6
Copyright (c) 2008, 2013, Oracle and/or its affiliates. All rights reserved.
```

```
Checking hardware configuration ... done.
Starting appliance configuration ..... done.
Press any key to begin configuring appliance: [*]
```

5. To begin configuration, press any key.

The shell interface configuration screen appears. The <=> character is displayed next to NET-0 near the top of the screen. If <X> appears by NET-0, check that all cable connections are secure.

```
Sun ZFS Storage 7120 Configuration
Copyright (c) 2008, 2013, Oracle and/or its affiliates. All rights reserved.
```

```
NET-0 <=>  NET-1 <X>  NET-2 <X>  NET-3 <X>
```

```
Host Name: hostname
DNS Domain: us.oracle.com
IP Address: 192.168.1.10
IP Netmask: 255.255.254.0
Default Router: 192.168.1.1
DNS Server: 192.168.1.1
* Password: @@@@
* Re-enter Password: @@@@
```

Please enter the required (*) configuration data

```
ESC-1: Done  ESC-2: Help  ESC-3: Halt  ESC-4: Reboot  ESC-5: Info
```

For help, see <http://www.oracle.com/goto/zfs7120>

- 6. Verify the information on the screen and enter values for fields that are not populated.**
- 7. To apply all of the values, either press ESC-1 or F1, or press Enter after confirming your new password.**

The final screen appears, confirming that your appliance is ready for initial configuration. Two web browser links are shown for configuration using the browser user interface (BUI); you can use either the host name, if assigned, or the IP address.

```
Sun ZFS Storage 7120 Configuration
Copyright (c) 2008, 2013, Oracle and/or its affiliates. All rights reserved.
```

Your new appliance is now ready for configuration. To configure your appliance, use a web browser to visit the following link:

```
https://hostname.us.oracle.com:215/
```

If your network administrator has not yet assigned the network name you chose for the appliance, you can also configure your appliance using the link:

```
https://192.168.1.10:215/
```

Next Steps

- To perform initial configuration through the BUI using any client on the same network, see [“Performing Initial Configuration \(BUI\)” on page 213](#). It is strongly recommended that you select this method for initial configuration of clustered controllers.
- To perform initial configuration through the CLI, see [“Performing Initial Configuration \(CLI\)” on page 227](#).

▼ Performing Initial Configuration (BUI)

Use this procedure, which is a step-by-step utility, to complete initial configuration of network interfaces, the Domain Name Service (DNS), time settings, name services, directory services, storage, and remote support on the appliance. This procedure is for standalone and clustered appliance configuration.

Note - If you are installing clustered controllers, it is strongly recommended that you use the BUI for initial configuration.

For clustered controllers, configure only the primary controller. Do not attempt initial configuration on both controllers independently. For more information about clustering, see [“Appliance Cluster Configuration” in Oracle ZFS Storage Appliance Administration Guide, Release OS8.8.0](#).

- Before You Begin**
- Gather the following information for the interfaces and services you will set up, and network configuration details.

Note - LDAP and NIS are optional for setup, but recommended. LDAP is preferred to NIS; do not run NIS and LDAP at the same time.

- Default router IP address
- IP address and netmask for the management interface (two if clustered controllers)
- IP address and netmask for the data interface (two if clustered controllers)
- DNS/NIS/LDAP domain name
- DNS IP address(es)
- NIS server IP address(es)
- NTP server IP address
- For LDAP:
 - LDAP server IP addresses

- Base search domain name
- Recursive or non-recursive search
- Authentication method: anonymous, self, or proxy (specific user)
- SSL/TLS usage
- You can skip any or all configuration screens by clicking COMMIT without making any changes. For the final and registration step, click LATER if you want to complete the screen later. To return to the beginning of the configuration utility, go to Maintenance > System and click INITIAL SETUP.

1. **Ensure you have configured the system as described in “Configuring the System” on page 210.**
2. **Direct your browser to the appliance using either the IP address or host name you assigned during system configuration as follows:**

`https://ipaddress:215` or `https://hostname:215`

The login screen appears.

Note - If the login screen does not appear and an error message is displayed instead, add an exception and download the certificate.

3. **Log in to the appliance:**

A screenshot of a web-based login interface. It features two input fields: one for 'Username' and one for 'Password'. Below the password field is a button labeled 'LOGIN' with a small lock icon to its right. The background is a light gray color.

- a. **Username - Enter root.**
 - b. **Password - Password you assigned during system configuration.**
 - c. **Click LOGIN or press Enter.**
4. **To begin initial configuration, click START.**

- If configuring clustered controllers, go to step 5.
- If configuring a standalone controller, go to step 6.



5. To configure clustered controllers, click CLUSTER.

Note - Optionally, click SKIP to configure this device as a standalone controller, and go to step 6. To configure clustered controllers later, see [“Upgrading a Standalone Appliance to a Clustered Configuration \(BUI\)”](#) in *Oracle ZFS Storage Appliance Administration Guide, Release OS8.8.0*.

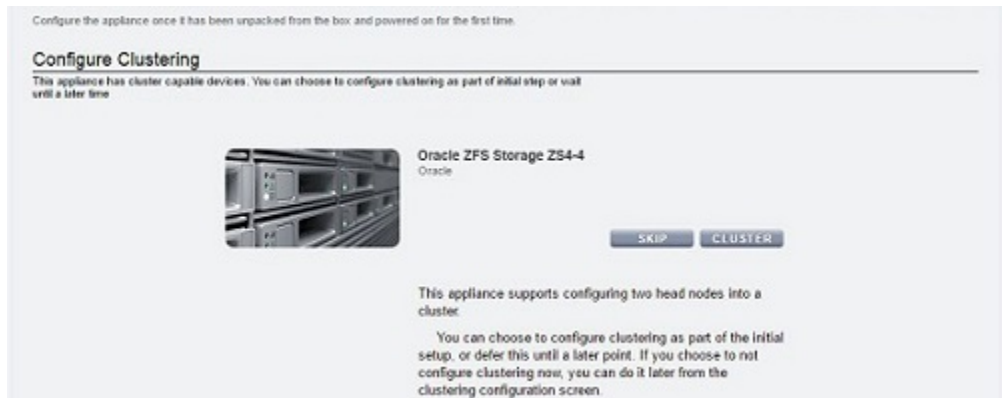

- a. **Ensure that there are three solid lines in the diagram of active cluster links and click COMMIT.**

If you do not see three solid lines, ensure that the three cluster cables connecting the two controllers together are properly connected and secure in their connectors. The system automatically senses these cables in real-time.

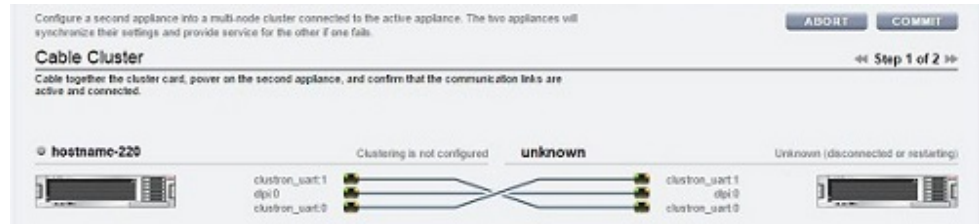

- b. **Set the appliance name and password for the peer controller:**

- **Appliance Name** - Enter the peer controller name (must be different from primary controller name).
- **Root Password** - Enter the same password that you set for the appliance during system configuration.
- **Confirm Password** - Re-enter the password.



- c. **Click COMMIT.**

A status bar in the masthead displays the progress.

6. **Configure the appliance networking interfaces.**

Note - You can create a management interface now, or at another time using a task in “Configuring Management Interfaces” in *Oracle ZFS Storage Appliance Administration Guide, Release OS8.8.0*.



For detailed information, see the following topics:

- “Working with Network Configuration” in *Oracle ZFS Storage Appliance Administration Guide, Release OS8.8.0*
- “Network Configuration” in *Oracle ZFS Storage Appliance Administration Guide, Release OS8.8.0*

To create a management interface now, use the following steps as an example:

- a. Click the add icon  next to Datalinks.
- b. In the Network Datalink dialog box, set the following minimum datalink properties.
 - VNIC - Select this check box.
 - Name - Enter a name for the datalink.

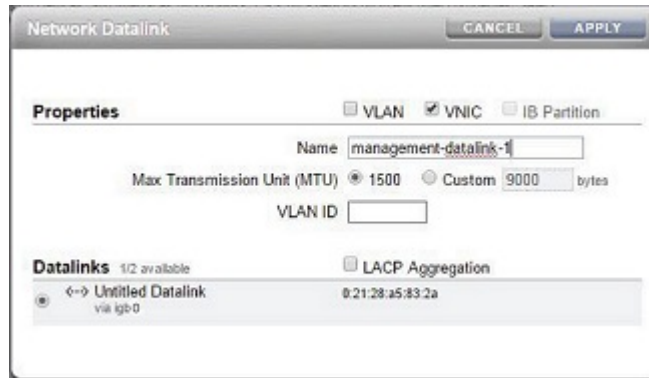

For detailed information, see the following tasks:

- [“Creating a VNIC Without a VLAN ID for Clustered Controllers \(BUI\)”](#) in *Oracle ZFS Storage Appliance Administration Guide, Release OS8.8.0*
- [“Creating VNICs with the Same VLAN ID for Clustered Controllers \(BUI\)”](#) in *Oracle ZFS Storage Appliance Administration Guide, Release OS8.8.0*

c. **Click APPLY.**

d. **Drag the resulting datalink to the Interfaces column.**

e. **In the Network Interface dialog box, set the following minimum interface properties:**

- **Name** - Type a name for the interface.
- **Enable Interface** - Select this check box to enable the interface.
- **Allow Administration** - Select this check box to make this a management interface, which enables BUI connections on port 215 and CLI connections on ssh port 22.
- **Use IPv4 Protocol** or **Use IPv6 Protocol** - Select a protocol, its type of address, and enter one or more IP addresses in CIDR notation.

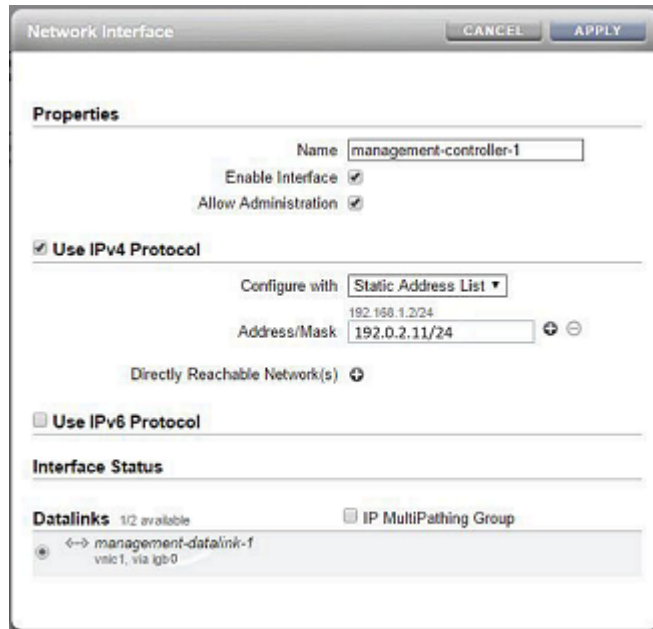

- f. Click **APPLY**.
- g. For clustered controllers, repeat steps a-f for the second controller, and choose a unique controller name.



- h. Click the trash icon  next to the default interface, named **Untitled Interface**, to destroy it and click **APPLY**.

- i. **In the Update Default Route dialog box, type the Default Gateway and select an Interface from the drop-down menu. Click COMMIT WITH ROUTE.**

The default gateway is the default router IP address. For the interface, select the datalink that you assigned to the first management interface.

Note - It is strongly recommended to set a route because it enables communication with the appliance via the BUI and CLI. Without a route, the only means of communication with the appliance is through an Oracle ILOM connection to the SP.

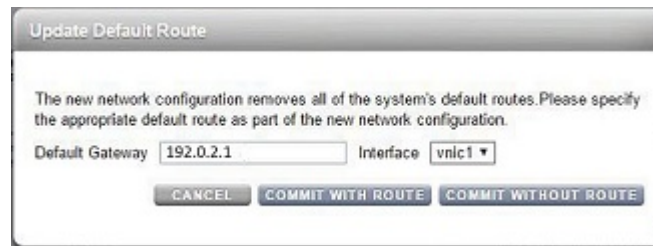

- j. **To configure additional routing, go to step 7. Otherwise, click COMMIT and skip to step 8.**
7. **(Optional) To configure additional routing, use the following steps.**

For clustered controllers and if not using a VNIC, create a route on each interface that is assigned to a controller. For detailed routing information, see [“Configuring Network Routing” in Oracle ZFS Storage Appliance Administration Guide, Release OS8.8.0.](#)

- a. **Click the add icon  next to Routing Table Entries.**

- b. **In the Insert Static Route dialog box, set the following properties:**

- **Family** - Select IPv4
- **Kind** - Select Default
- **Gateway** - Type the same default gateway from step 6i.

- **Interface** - Select the interface for which you want to configure routing.

Insert Static Route

CANCEL ADD

Family IPv4
 IPv6

Kind Default
 Network

Destination

Gateway

Interface

- c. **Click ADD.**

The new route appears in the routing table.

Initial configuration of appliance settings. COMMIT

Configure Networking Step 1 of 6

Configure the appliance network interfaces. The first network interface has been configured for you using the settings you provided at the serial console.

Network Configuration Addresses Routing

Multihoming model Loose Adaptive Strict

Routing Table Entries 5 Total

ALL | STATIC | DYNAMIC | DHCP | SYSTEM | DIRECT

DESTINATION	GATEWAY	FAMILY	TYPE	STATUS	INTERFACE
default	192.0.2.1	IPv4	static	active	management-controller-2 IPv4 static, 192.0.2.12/24, via vnic2
default	192.0.2.1	IPv4	static	active	management-controller-1 IPv4 static, 192.0.2.11/24, via vnic1
192.0.2.22/24	192.0.2.12	IPv4	system	active	management-controller-2 IPv4 static, 192.0.2.12/24, via vnic2
192.0.2.22/24	192.0.2.11	IPv4	system	active	management-controller-1 IPv4 static, 192.0.2.11/24, via vnic1
198.51.100.1/24	198.51.100.77	IPv4	system	active	

- d. **Click COMMIT.**

- 8. **Configure the Domain Name Service (DNS) and click COMMIT.**

For detailed information, see “DNS Configuration” in *Oracle ZFS Storage Appliance Administration Guide, Release OS8.8.0*.

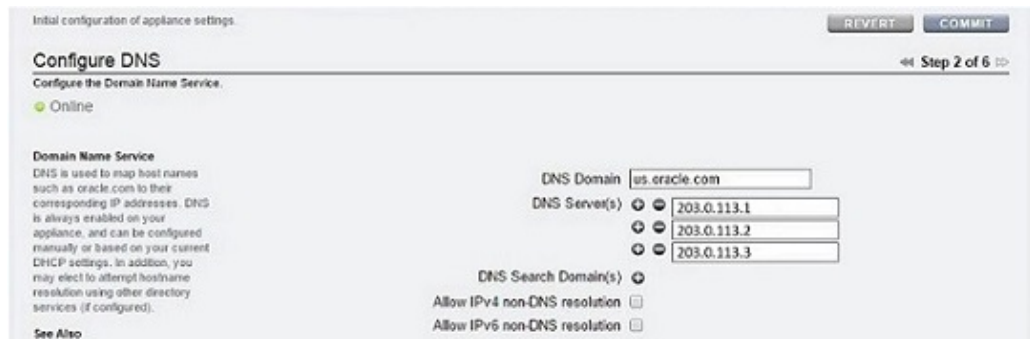

9. **Configure the Network Time Protocol (NTP) to synchronize the appliance clock by performing one of the following options and then click COMMIT:**
- To automatically discover the NTP server and set the appliance time to match your network time, enter the multicast address.
 - To manually set the appliance time to match your network time, enter the NTP server name (s) and select an authentication key.
 - To set the appliance (server) time to match your client browser time, click SYNC.

Note - If you share filesystems using SMB and Active Directory, the client clocks must be synchronized to within five minutes of the appliance clock to avoid user authentication errors. One way to ensure clock synchronization is to configure the appliance and the SMB clients to use the same NTP server.

For detailed information, see “NTP Configuration” in *Oracle ZFS Storage Appliance Administration Guide, Release OS8.8.0*.

Initial configuration of appliance settings. REVERT COMMIT

Configure Time Step 3 of 6

Configure the Network Time Protocol

Disabled

Network Time Protocol
Configure the network time protocol. If you choose to leave the NTP service disabled, you may manually set the time and date to match your time according to your web browser.

See Also
Help: NTP
NTP Project
Wikipedia: NTP

RESTART

ENABLE

NTP Settings

Discover NTP server via multicast address:
203.0.113.4

Manually specify NTP server(s):

SERVER	AUTH KEY
pool.ntp.org	<None>

NTP Authentication Keys

No NTP authentication keys have been established.
Click the button above to add authentication keys.

Clock

Server Time: 2016-3-28 15:25:03
Client Time: 2016-3-28 15:25:03

SYNC

10. Configure name services.

For detailed information, see “Configuring Services” in *Oracle ZFS Storage Appliance Administration Guide, Release OS8.8.0*.

Note - Active Directory has two modes: domain and workgroup mode, which dictate how SMB users are authenticated. In domain mode, SMB clients are authenticated through the Active Directory domain controller, and you must ensure that the times on the appliance and the domain controller match within five minutes.

- a. Click **CONFIGURE** for the appropriate service, set its parameters, and click **APPLY**.

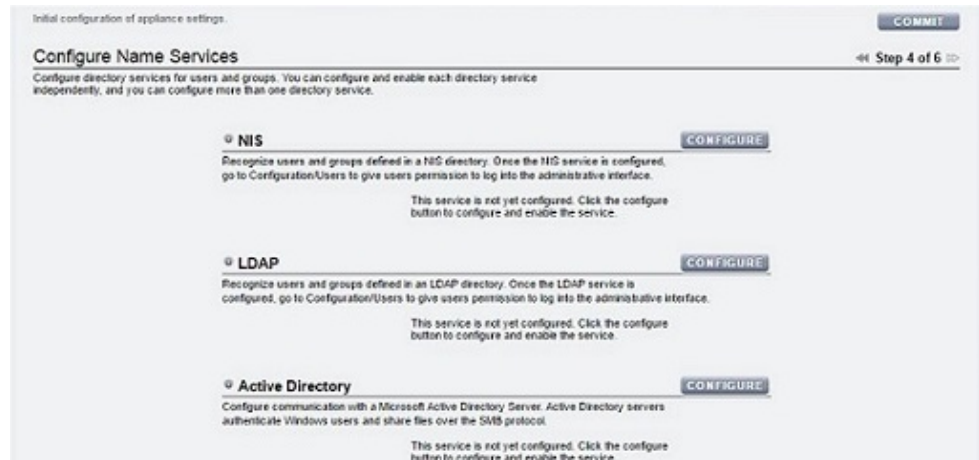

- b. When the summary of Name Services settings is displayed, click **COMMIT** if all settings are complete and correct. Otherwise, click **CONFIGURE** to adjust the settings for a service.

11. Configure storage pools and click COMMIT.

For detailed information, see [“Configuring Storage” in Oracle ZFS Storage Appliance Administration Guide, Release OS8.8.0.](#)

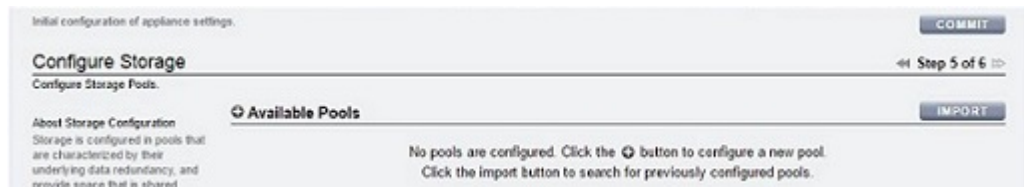

12. Perform one of the following steps:

- **To register your appliance for remote support, complete the fields and click REGISTER.**

If you do not have an Oracle support account, click LATER and see [“Phone Home Configuration” in Oracle ZFS Storage Appliance Administration Guide, Release OS8.8.0.](#)

- To skip remote support configuration, click LATER.



13. Perform one of the following steps:

- If you clicked REGISTER in the previous step, read the privacy statement and click OK.

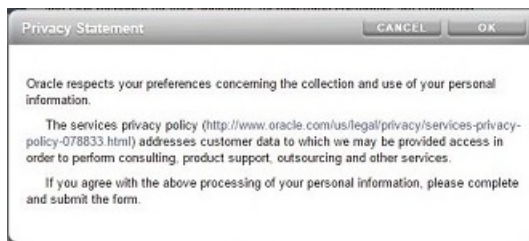

- If you clicked LATER in the previous step, click OK to confirm that you want to skip registration.

You can return to the registration and support screen by going to Configuration > Services > Phone Home. For more information, see [“Phone Home Configuration”](#) in *Oracle ZFS Storage Appliance Administration Guide, Release OS8.8.0*.



14. If you configured clustering, use following steps to failback the resources:
 - a. For the second management interface, click the drop-down menu under OWNER and select the peer controller.
 - b. Click FAILBACK to failback the configured resources to the cluster peer.
 - c. Click OK to confirm your action.
 - d. Click COMMIT.

This creates an active-active configuration.



Next Steps

- If a standalone controller, see [“Upgrading the Software”](#) in *Oracle ZFS Storage Appliance Customer Service Manual*.
- If clustered controllers, see [“Locking Cluster Management Interfaces \(BUI\)”](#) in *Oracle ZFS Storage Appliance Administration Guide, Release OS8.8.0*.

- If you did not configure the management interface yet, see the tasks in [“Configuring Management Interfaces”](#) in *Oracle ZFS Storage Appliance Administration Guide, Release OS8.8.0*.

Related Topics

- For an overview of network interface configuration, see [“Working with Network Configuration”](#) in *Oracle ZFS Storage Appliance Administration Guide, Release OS8.8.0*.
- For further configuration, see [“Configuring the Appliance”](#) in *Oracle ZFS Storage Appliance Administration Guide, Release OS8.8.0*
- For more information about cluster configuration, see [“Appliance Cluster Configuration”](#) in *Oracle ZFS Storage Appliance Administration Guide, Release OS8.8.0*
- To change the root password, see [“Changing a User Password \(BUI\)”](#) in *Oracle ZFS Storage Appliance Administration Guide, Release OS8.8.0*

▼ Performing Initial Configuration (CLI)

Use this procedure, which is a step-by-step utility, to complete initial configuration of network interfaces, the Domain Name Service (DNS), time settings, name services, directory services, storage, and remote support on the appliance using the command line interface (CLI).

Note - If installing clustered controllers, it is strongly recommended that you use the BUI for initial configuration, as described in [“Performing Initial Configuration \(BUI\)”](#) on page 213.

Each step begins by printing its help, which can be reprinted by typing `help`. Use the `done` command to complete each step. In the examples, the existing settings (obtained from the DHCP server) are checked and accepted by typing `done`. To customize them, enter each context (`datalinks`, `devices` and `interfaces`) and type `help` to see available actions for that context.

- Before You Begin**
- Ensure you have configured the system as described in [“Configuring the System”](#) on page 210.
 - This procedure assumes you have just completed configuration of the network interface and are using the same administrative client to access the CLI.

1. Log in using the administrative password that you created during system configuration.

```
hostname console login: root
```

```
Password:
```

To setup your system, you will be taken through a series of steps; as the setup process advances to each step, the help message for that step will be displayed.

Press any key to begin initial configuration ...

2. Configure the appliance network interfaces.

For detailed information, see the following topics:

- [“Working with Network Configuration” in Oracle ZFS Storage Appliance Administration Guide, Release OS8.8.0](#)
- [“Network Configuration” in Oracle ZFS Storage Appliance Administration Guide, Release OS8.8.0](#)

Note - You can create a management interface now, or at another time using a task in [“Configuring Management Interfaces” in Oracle ZFS Storage Appliance Administration Guide, Release OS8.8.0](#).

aksh: starting configuration with "net" ...

Configure Networking. Configure the appliance network interfaces. The first network interface has been configured for you, using the settings you provided at the serial console.

Subcommands that are valid in this context:

```
datalink      => Manage datalinks

devices       => Manage devices

interfaces    => Manage interfaces

help [topic]  => Get context-sensitive help. If [topic] is specified,
                it must be one of "builtins", "commands", "general",
                "help" or "script".

show          => Show information pertinent to the current context

abort         => Abort this task (potentially resulting in a
                misconfigured system)

done          => Finish operating on "net"
```

```
hostname:maintenance system setup net> devices show
Devices:
```

DEVICE	UP	MAC	SPEED
igb0	true	0:14:4f:8d:59:aa	1000 Mbit/s
igb1	false	0:14:4f:8d:59:ab	0 Mbit/s

```

    igb2 false    0:14:4f:8d:59:ac    0 Mbit/s
    igb3 false    0:14:4f:8d:59:ad    0 Mbit/s

```

```

hostname:maintenance system setup net> datalinks show
Datalinks:

```

DATALINK	CLASS	LINKS	LABEL
igb0	device	igb0	Untitled DataLink

```

hostname:maintenance system setup net> interfaces show
Interfaces:

```

INTERFACE	STATE	CLASS	LINKS	ADDRS	LABEL
igb0	up	ip	igb0	192.168.2.80/22	Untitled Interface

```

hostname:maintenance system setup net> done

```

To create a management interface now, use the following steps as an example:

a. Go to maintenance system setup net, and then enter interfaces.

```

hostname:maintenance system setup net> interfaces

```

b. Enter show to view the interface. Enter cd .. to return to the context for the next step.

```

hostname:maintenance system setup net interfaces> show
Interfaces:

```

INTERFACE	STATE	CLASS	LINKS	ADDRS	LABEL
igb0	up	ip	igb0	192.0.2.11/24	Untitled Interface

```

hostname:maintenance system setup net interfaces> cd ..

```

c. Configure routing for the interface labeled Untitled Interface. Enter cd .. to return to the correct context for the next step.

For detailed information, see [“Configuring Network Routing” in Oracle ZFS Storage Appliance Administration Guide, Release OS8.8.0.](#)

```

hostname:maintenance system setup net> routing
hostname:maintenance system setup net routing> create
hostname:maintenance system setup net route (uncommitted)> set destination=0.0.0.0
                        destination = 0.0.0.0 (uncommitted)
hostname:maintenance system setup net route (uncommitted)> set mask=0
                        mask = 0 (uncommitted)
hostname:maintenance system setup net route (uncommitted)> set interface=igb0

```

```

        interface = igb0 (uncommitted)
hostname:maintenance system setup net route (uncommitted)> set gateway=192.0.2.1
        gateway = 192.168.56.101 (uncommitted)
hostname:maintenance system setup net route (uncommitted)> set family=IPv4
        family = IPv4 (uncommitted)
hostname:maintenance system setup net route (uncommitted)> commit
hostname:maintenance system setup net routing> cd ..

```

- d. **Enter `interfaces`, select the interface labeled `Untitled Interface`, and then enter `show` to view its properties.**

```

hostname:maintenance system setup net> interfaces
hostname:maintenance system setup net interfaces> select igb0
hostname:maintenance system setup net interfaces igb0> show
Properties:

```

```

        state = up
        curaddrs = 192.0.2.11/24
        class = ip
        label = Untitled Interface
        enable = true
        admin = true
        links = igb0
        v4addrs =
        v4dhcp = true
        v6addrs =
        v6dhcp = false

```

- e. **Set an IPv4 address, change the protocol from DHCP to static, and set a new label to indicate that it is a management interface. Enter `cd ../..` to return to the correct context for the next step.**

```

hostname:maintenance system setup net interfaces igb0> set v4addrs=192.0.2.11/24
        v4addrs = 192.168.1.101/24 (uncommitted)
hostname:maintenance system setup net interfaces igb0> set v4dhcp=false
        v4dhcp = false (uncommitted)
hostname:maintenance system setup net interfaces igb0(uncommitted)> set
  label=management-controller
        label = management-controller (uncommitted)
hostname:maintenance system setup net interfaces igb0 (uncommitted)> commit
hostname:maintenance system setup net interfaces igb0> cd ../..

```

3. **Configure the Domain Name Service (DNS).**

For detailed information, see “DNS Configuration” in [Oracle ZFS Storage Appliance Administration Guide, Release OS8.8.0](#).

Configure DNS. Configure the Domain Name Service.

Subcommands that are valid in this context:

```

help [topic]      => Get context-sensitive help. If [topic] is specified,
                    it must be one of "builtins", "commands", "general",
                    "help", "script" or "properties".

show              => Show information pertinent to the current context

commit           => Commit current state, including any changes

abort            => Abort this task (potentially resulting in a
                    misconfigured system)

done             => Finish operating on "dns"

get [prop]       => Get value for property [prop]. ("help properties"
                    for valid properties.) If [prop] is not specified,
                    returns values for all properties.

set [prop]       => Set property [prop] to [value]. ("help properties"
                    for list valid properties.) For properties taking list
                    values, [value] should be a comma-separated list of
                    values.

```

```

hostname:maintenance system setup dns> show
Properties:
    <status> = online
    domain = sun.com
    servers = 198.51.100.1

hostname:maintenance system setup dns> set domain=sf.fishworks.com
    domain = sf.fishworks.com (uncommitted)
hostname:maintenance system setup dns> set servers=198.51.100.2
    servers = 198.51.100.2 (uncommitted)
hostname:maintenance system setup dns> commit
hostname:maintenance system setup dns> done
aksh: done with "dns", advancing configuration to "ntp" ...

```

4. Configure the Network Time Protocol (NTP) to synchronize the appliance clock.

Note - If you share filesystems using SMB and Active Directory, the client clocks must be synchronized to within five minutes of the appliance clock to avoid user authentication errors. One way to ensure clock synchronization is to configure the appliance and the SMB clients to use the same NTP server.

For detailed information, see [“NTP Configuration” in Oracle ZFS Storage Appliance Administration Guide, Release OS8.8.0.](#)

Configure Time. Configure the Network Time Protocol.

Subcommands that are valid in this context:

help [topic]	=> Get context-sensitive help. If [topic] is specified, it must be one of "builtins", "commands", "general", "help", "script" or "properties".
show	=> Show information pertinent to the current context
commit	=> Commit current state, including any changes
abort	=> Abort this task (potentially resulting in a misconfigured system)
done	=> Finish operating on "ntp"
enable	=> Enable the ntp service
disable	=> Disable the ntp service
get [prop]	=> Get value for property [prop]. ("help properties" for valid properties.) If [prop] is not specified, returns values for all properties.
set [prop]	=> Set property [prop] to [value]. ("help properties" for valid properties.) For properties taking list values, [value] should be a comma-separated list of values.

```
hostname:maintenance system setup ntp> set servers=0.pool.ntp.org
servers = 0.pool.ntp.org (uncommitted)
hostname:maintenance system setup ntp> commit
hostname:maintenance system setup ntp> done
aksh: done with "ntp", advancing configuration to "directory" ...
```

5. Configure name services.

For detailed information, see [“Configuring Services” in Oracle ZFS Storage Appliance Administration Guide, Release OS8.8.0.](#)

Note - Active Directory has two modes: domain and workgroup mode, which dictate how SMB users are authenticated. In domain mode, SMB clients are authenticated through the Active Directory domain controller, and you must ensure that the times on the appliance and the domain controller match within five minutes.

NIS is an older directory protocol that is not very secure, and largely replaced by LDAP. It is not recommended to run NIS and LDAP at the same time because they use the same domain name setting.

Configure Name Services. Configure directory services for users and groups. You can configure and enable each directory service independently, and you can configure more than one directory service.

Subcommands that are valid in this context:

```

nis                => Configure NIS

ldap               => Configure LDAP

ad                 => Configure Active Directory

help [topic]      => Get context-sensitive help. If [topic] is specified,
                    it must be one of "builtins", "commands", "general",
                    "help" or "script".

show               => Show information pertinent to the current context

abort              => Abort this task (potentially resulting in a
                    misconfigured system)

done               => Finish operating on "directory"

```

```

hostname:maintenance system setup directory> nis
hostname:maintenance system setup directory nis> show
Properties:
    <status> = online
    domain = sun.com
    broadcast = true
    ypservers =

hostname:maintenance system setup directory nis> set domain=fishworks
    domain = fishworks (uncommitted)
hostname:maintenance system setup directory nis> commit
hostname:maintenance system setup directory nis> done
hostname:maintenance system setup directory> done
aksh: done with "directory", advancing configuration to "support" ...

```

6. Configure storage pools.

For detailed information, see [“Configuring Storage” in Oracle ZFS Storage Appliance Administration Guide, Release OS8.8.0.](#)

Configure Storage.

Subcommands that are valid in this context:

```

help [topic]          => Get context-sensitive help. If [topic] is specified,
                        it must be one of "builtins", "commands", "general",
                        "help", "script" or "properties".

show                  => Show information pertinent to the current context

commit                => Commit current state, including any changes

done                  => Finish operating on "storage"

config <pool>         => Configure the storage pool

unconfig              => Unconfigure the storage pool

add                   => Add additional storage to the storage pool

import                => Search for existing or destroyed pools to import

scrub <start|stop>   => Start or stop a scrub

get [prop]            => Get value for property [prop]. ("help properties"
                        for valid properties.) If [prop] is not specified,
                        returns values for all properties.

set pool=[pool]       => Change current pool

```

```
hostname:maintenance system setup storage> show
```

```
Properties:
```

```

    pool = pool-0
    status = online
    profile = mirror
    log_profile = -
    cache_profile = -

```

```
hostname:maintenance system setup storage> done
```

```
aksh: done with "storage", advancing configuration to "support" ...
```

7. Configure remote support.

Note - You can configure remote support now, or at another time. If you do not have an Oracle support account, enter `done` without configuring remote support and complete it later. For more information about configuring remote support later or obtaining an Oracle support account, see [“Phone Home Configuration”](#) in *Oracle ZFS Storage Appliance Administration Guide, Release OS8.8.0*.

Remote Support. Register your appliance and configure remote monitoring.

Subcommands that are valid in this context:

```
tags           => Configure service tags

scrk           => Configure phone home

help [topic]   => Get context-sensitive help. If [topic] is specified,
                 it must be one of "builtins", "commands", "general",
                 "help" or "script".

show           => Show information pertinent to the current context

abort         => Abort this task (potentially resulting in a
                 misconfigured system)

done          => Finish operating on "support"
```

```
hostname:maintenance system setup support> done
aksh: initial configuration complete!
```

Next Steps

- If you did not configure the management interface yet, see the tasks in [“Configuring Management Interfaces”](#) in *Oracle ZFS Storage Appliance Administration Guide, Release OS8.8.0*.
- See [“Upgrading the Software”](#) in *Oracle ZFS Storage Appliance Customer Service Manual*.

Related Topics

- For an overview of network interface configuration, see [“Working with Network Configuration”](#) in *Oracle ZFS Storage Appliance Administration Guide, Release OS8.8.0*.
- For further configuration, see [“Configuring the Appliance”](#) in *Oracle ZFS Storage Appliance Administration Guide, Release OS8.8.0*.
- To change the root password, see [“Changing a User Password \(CLI\)”](#) in *Oracle ZFS Storage Appliance Administration Guide, Release OS8.8.0*.

Troubleshooting Hardware Faults

In rare cases, faults associated with uncorrectable CPU errors are not diagnosable or displayed in the controller. These faults will be preserved by and observable in the Oracle ILOM, located in the service processor. Connect to Oracle ILOM on the server platform to diagnose hardware faults that do not appear in the BUI.



Caution - Failure to configure Oracle ILOM connectivity might lead to longer than necessary hardware fault diagnosis and resolution times.

For more detailed information about Oracle ILOM, see “[Using Oracle ILOM to Diagnose Hardware Faults](#)” in *Oracle ZFS Storage Appliance Cabling Guide*. Also see the Oracle ILOM documentation located in the documentation library for this software release at <http://docs.oracle.com/en/storage/>.

▼ Connecting to Oracle ILOM

After configuring the system and performing initial configuration, it is recommended that you retain a connection to Oracle ILOM, located in the controller SP, for troubleshooting hardware problems that do not otherwise appear in the appliance software.

The server Oracle ILOM provides options for (i) network and (ii) serial port connectivity. Network connection is the preferred choice, as the Oracle ILOM serial port does not always allow adequate means of platform data collection.

- 1. Perform one of the following SP connections:**
 - For a network SP connection (recommended), attach an Ethernet cable from the NET MGT port on the rear panel of the controller to your Ethernet switch.
 - For a serial SP connection, attach a serial cable from the SER MGT port on the rear panel of the controller to the serial port on the administrative client. Use a DB9 to RJ45 adapter if necessary.
- 2. For clustered controllers, repeat for the second controller.**

