

# Oracle Database Appliance Owner's Guide

**ORACLE**

**Part No: E92504-01**  
January 2018



**Part No: E92504-01**

Copyright © 2018, Oracle and/or its affiliates. All rights reserved.

This software and related documentation are provided under a license agreement containing restrictions on use and disclosure and are protected by intellectual property laws. Except as expressly permitted in your license agreement or allowed by law, you may not use, copy, reproduce, translate, broadcast, modify, license, transmit, distribute, exhibit, perform, publish, or display any part, in any form, or by any means. Reverse engineering, disassembly, or decompilation of this software, unless required by law for interoperability, is prohibited.

The information contained herein is subject to change without notice and is not warranted to be error-free. If you find any errors, please report them to us in writing.

If this is software or related documentation that is delivered to the U.S. Government or anyone licensing it on behalf of the U.S. Government, then the following notice is applicable:

U.S. GOVERNMENT END USERS. Oracle programs, including any operating system, integrated software, any programs installed on the hardware, and/or documentation, delivered to U.S. Government end users are "commercial computer software" pursuant to the applicable Federal Acquisition Regulation and agency-specific supplemental regulations. As such, use, duplication, disclosure, modification, and adaptation of the programs, including any operating system, integrated software, any programs installed on the hardware, and/or documentation, shall be subject to license terms and license restrictions applicable to the programs. No other rights are granted to the U.S. Government.

This software or hardware is developed for general use in a variety of information management applications. It is not developed or intended for use in any inherently dangerous applications, including applications that may create a risk of personal injury. If you use this software or hardware in dangerous applications, then you shall be responsible to take all appropriate fail-safe, backup, redundancy, and other measures to ensure its safe use. Oracle Corporation and its affiliates disclaim any liability for any damages caused by use of this software or hardware in dangerous applications.

Oracle and Java are registered trademarks of Oracle and/or its affiliates. Other names may be trademarks of their respective owners.

Intel and Intel Xeon are trademarks or registered trademarks of Intel Corporation. All SPARC trademarks are used under license and are trademarks or registered trademarks of SPARC International, Inc. AMD, Opteron, the AMD logo, and the AMD Opteron logo are trademarks or registered trademarks of Advanced Micro Devices. UNIX is a registered trademark of The Open Group.

This software or hardware and documentation may provide access to or information about content, products, and services from third parties. Oracle Corporation and its affiliates are not responsible for and expressly disclaim all warranties of any kind with respect to third-party content, products, and services unless otherwise set forth in an applicable agreement between you and Oracle. Oracle Corporation and its affiliates will not be responsible for any loss, costs, or damages incurred due to your access to or use of third-party content, products, or services, except as set forth in an applicable agreement between you and Oracle.

**Documentation Accessibility**

For information about Oracle's commitment to accessibility, visit the Oracle Accessibility Program website at <http://www.oracle.com/pls/topic/lookup?ctx=acc&id=docacc>.

**Access to Oracle Support**

Oracle customers that have purchased support have access to electronic support through My Oracle Support. For information, visit <http://www.oracle.com/pls/topic/lookup?ctx=acc&id=info> or visit <http://www.oracle.com/pls/topic/lookup?ctx=acc&id=trs> if you are hearing impaired.

**Référence: E92504-01**

Copyright © 2018, Oracle et/ou ses affiliés. Tous droits réservés.

Ce logiciel et la documentation qui l'accompagne sont protégés par les lois sur la propriété intellectuelle. Ils sont concédés sous licence et soumis à des restrictions d'utilisation et de divulgation. Sauf stipulation expresse de votre contrat de licence ou de la loi, vous ne pouvez pas copier, reproduire, traduire, diffuser, modifier, accorder de licence, transmettre, distribuer, exposer, exécuter, publier ou afficher le logiciel, même partiellement, sous quelque forme et par quelque procédé que ce soit. Par ailleurs, il est interdit de procéder à toute ingénierie inverse du logiciel, de le désassembler ou de le décompiler, excepté à des fins d'interopérabilité avec des logiciels tiers ou tel que prescrit par la loi.

Les informations fournies dans ce document sont susceptibles de modification sans préavis. Par ailleurs, Oracle Corporation ne garantit pas qu'elles soient exemptes d'erreurs et vous invite, le cas échéant, à lui en faire part par écrit.

Si ce logiciel, ou la documentation qui l'accompagne, est livré sous licence au Gouvernement des Etats-Unis, ou à quiconque qui aurait souscrit la licence de ce logiciel pour le compte du Gouvernement des Etats-Unis, la notice suivante s'applique:

U.S. GOVERNMENT END USERS. Oracle programs, including any operating system, integrated software, any programs installed on the hardware, and/or documentation, delivered to U.S. Government end users are "commercial computer software" pursuant to the applicable Federal Acquisition Regulation and agency-specific supplemental regulations. As such, use, duplication, disclosure, modification, and adaptation of the programs, including any operating system, integrated software, any programs installed on the hardware, and/or documentation, shall be subject to license terms and license restrictions applicable to the programs. No other rights are granted to the U.S. Government.

Ce logiciel ou matériel a été développé pour un usage général dans le cadre d'applications de gestion des informations. Ce logiciel ou matériel n'est pas conçu ni n'est destiné à être utilisé dans des applications à risque, notamment dans des applications pouvant causer des dommages corporels. Si vous utilisez ce logiciel ou matériel dans le cadre d'applications dangereuses, il est de votre responsabilité de prendre toutes les mesures de secours, de sauvegarde, de redondance et autres mesures nécessaires à son utilisation dans des conditions optimales de sécurité. Oracle Corporation et ses affiliés déclinent toute responsabilité quant aux dommages causés par l'utilisation de ce logiciel ou matériel pour ce type d'applications.

Oracle et Java sont des marques déposées d'Oracle Corporation et/ou de ses affiliés. Tout autre nom mentionné peut correspondre à des marques appartenant à d'autres propriétaires qu'Oracle.

Intel et Intel Xeon sont des marques ou des marques déposées d'Intel Corporation. Toutes les marques SPARC sont utilisées sous licence et sont des marques ou des marques déposées de SPARC International, Inc. AMD, Opteron, le logo AMD et le logo AMD Opteron sont des marques ou des marques déposées d'Advanced Micro Devices. UNIX est une marque déposée d'The Open Group.

Ce logiciel ou matériel et la documentation qui l'accompagne peuvent fournir des informations ou des liens donnant accès à des contenus, des produits et des services émanant de tiers. Oracle Corporation et ses affiliés déclinent toute responsabilité ou garantie expresse quant aux contenus, produits ou services émanant de tiers, sauf mention contraire stipulée dans un contrat entre vous et Oracle. En aucun cas, Oracle Corporation et ses affiliés ne sauraient être tenus pour responsables des pertes subies, des coûts occasionnés ou des dommages causés par l'accès à des contenus, produits ou services tiers, ou à leur utilisation, sauf mention contraire stipulée dans un contrat entre vous et Oracle.

**Accessibilité de la documentation**

Pour plus d'informations sur l'engagement d'Oracle pour l'accessibilité à la documentation, visitez le site Web Oracle Accessibility Program, à l'adresse <http://www.oracle.com/pls/topic/lookup?ctx=acc&id=docacc>.

**Accès aux services de support Oracle**

Les clients Oracle qui ont souscrit un contrat de support ont accès au support électronique via My Oracle Support. Pour plus d'informations, visitez le site <http://www.oracle.com/pls/topic/lookup?ctx=acc&id=info> ou le site <http://www.oracle.com/pls/topic/lookup?ctx=acc&id=trs> si vous êtes malentendant.



# Contents

---

<b>Preface</b> .....	7
<b>1 Oracle Database Appliance Setup Tasks</b> .....	9
Task Checklist .....	9
<b>2 Overview of Oracle Database Appliance</b> .....	11
Supported Components and Capabilities .....	11
Oracle Database Appliance X7-2 Series Components and Capabilities .....	12
Oracle Database Appliance X6-2 Series Components and Capabilities .....	14
Oracle Database Appliance Version 1 and Models X3-2, X4-2 and X5-2 Components and Capabilities .....	18
Oracle Database Appliance X7-2S/X7-2M Front and Back Panels .....	22
Oracle Database Appliance X7-2S/X7-2M Front Panel .....	22
Oracle Database Appliance X7-2S/X7-2M Back Panel .....	23
Oracle Database Appliance X7-2-HA Front and Back Panels .....	25
Oracle Database Appliance X7-2-HA Front Panel .....	25
Oracle Database Appliance X7-2-HA Back Panel .....	29
Oracle Database Appliance X6-2S/X6-2M/X6-2L Front and Back Panels .....	32
Oracle Database Appliance X6-2S/X6-2M Front Panel .....	33
Oracle Database Appliance X6-2S/X6-2M Back Panel .....	34
Oracle Database Appliance X6-2L Front Panel .....	35
Oracle Database Appliance X6-2L Back Panel .....	36
Oracle Database Appliance X6-2-HA Front and Back Panels .....	37
Oracle Database Appliance X6-2-HA Front Panel .....	37
Oracle Database Appliance X6-2-HA Back Panel .....	40
Oracle Database Appliance X5-2 Front and Back Panels .....	44
Oracle Database Appliance X5-2 Front Panel .....	44
Oracle Database Appliance X5-2 Back Panel .....	47
Oracle Database Appliance X3-2/X4-2 Front and Back Panels .....	51
Oracle Database Appliance X3-2/X4-2 Front Panel .....	51

Oracle Database Appliance X3-2/X4-2 Back Panel .....	54
Oracle Database Appliance Version 1 Front and Back Panels .....	58
Oracle Database Appliance Version 1 Front Panel .....	58
Oracle Database Appliance Version 1 Back Panel .....	60
Oracle Database Appliance Specifications .....	61
Physical Specifications .....	61
Electrical Specifications .....	63
Environmental Specifications .....	65
Technical Support .....	68
<b>3 Site Preparation .....</b>	<b>71</b>
Preparing Your Site .....	71
▼ Prepare Your Site .....	71
<b>4 Installing the System Into a Rack .....</b>	<b>73</b>
Task Overview .....	73
Optional Component Installation .....	74
Safety Precautions When Rackmounting .....	76
ESD Precautions .....	77
Rack Compatibility Requirements .....	77
Inserting Oracle Database Appliance Into a Rack .....	80
Inserting Oracle Database Appliance X6-2S/X6-2M/X6-2L and X7-2S/X7-2M Into a Rack .....	81
Inserting Oracle Database Appliance X3-2/X4-2/X5-2 and X6-2-HA/X7-2-HA Into a Rack .....	83
Inserting Oracle Database Appliance Version 1 Into a Rack .....	111
<b>Index .....</b>	<b>133</b>

# Preface

---

This preface provides the following information:

- [“Documentation and Feedback” on page 7](#)
- [“Change History” on page 7](#)

## Documentation and Feedback

Documentation	Link
All Oracle products	<a href="http://docs.oracle.com">http://docs.oracle.com</a>
Oracle Database Appliance	<a href="http://www.oracle.com/goto/oda/docs">http://www.oracle.com/goto/oda/docs</a>
Oracle Integrated Lights Out Manager (Oracle ILOM) 3.X and 4.X	<a href="http://www.oracle.com/goto/ilom/docs">http://www.oracle.com/goto/ilom/docs</a>

Provide feedback on this documentation:

<http://www.oracle.com/goto/docfeedback>

## Change History

The following lists the release history of this documentation set:

- January 2018. Initial publication.



# ◆◆◆ CHAPTER 1

## Oracle Database Appliance Setup Tasks

---

This chapter describes the tasks you must complete when setting up Oracle Database Appliance.

### Task Checklist

Step	Task	Refer to
1	Access the online product documentation for your release of Oracle Database Appliance.	<a href="http://www.oracle.com/goto/oda/docs">http://www.oracle.com/goto/oda/docs</a>
2	Review safety information before performing the installation.	<i>Oracle Database Appliance Series Safety and Compliance Guide</i> : Online at the product documentation site  <i>Important Safety Information for Oracle's Hardware Systems</i> : Printed document included in the Accessory Kit
3	Review system features and components.	<a href="#">Chapter 2, "Overview of Oracle Database Appliance"</a>
4	Complete the site preparation procedures.	<a href="#">Chapter 3, "Site Preparation"</a>
5	Rackmount the system.	<a href="#">Chapter 4, "Installing the System Into a Rack"</a>
6	Connect cables.	For the Oracle Database Appliance X6 and X7 series, refer to the appropriate <i>Deployment and User's Guide</i> .  For the Oracle Database Appliance X3-2/X4-2/X5-2 or Version 1, refer to the <i>Getting Started Guide</i>
7	Connect to Oracle Integrated Lights Out Manager (ILOM).	For the Oracle Database Appliance X6 and X7 series, refer to the appropriate <i>Deployment and User's Guide</i> .  For the Oracle Database Appliance X3-2/X4-2/X5-2 or Version 1, refer to the <i>Getting Started Guide</i>
8	Deploy Oracle Database Appliance software.	For the Oracle Database Appliance X6 and X7 series, refer to the appropriate <i>Deployment and User's Guide</i> .

## Task Checklist

---

Step	Task	Refer to
		For the Oracle Database Appliance X3-2/X4-2/ X5-2 or Version 1, refer to the <i>Getting Started Guide</i>

## Overview of Oracle Database Appliance

---

This chapter describes Oracle Database Appliance features. There are several versions of Oracle Database Appliance and this document covers all versions:

- Oracle Database Appliance X7-2S/X7-2M
- Oracle Database Appliance X7-2-HA (High Availability)
- Oracle Database Appliance X6-2S/X6-2M/X6-2L
- Oracle Database Appliance X6-2-HA (High Availability)
- Oracle Database Appliance X5-2
- Oracle Database Appliance X4-2
- Oracle Database Appliance X3-2
- Oracle Database Appliance Version 1 (also referred to as "original version" or "V1")

For information about Oracle Database Appliance features:

- [“Supported Components and Capabilities” on page 11](#)
- [“Oracle Database Appliance X7-2S/X7-2M Front and Back Panels” on page 22](#)
- [“Oracle Database Appliance X7-2-HA Front and Back Panels” on page 25](#)
- [“Oracle Database Appliance X6-2S/X6-2M/X6-2L Front and Back Panels” on page 32](#)
- [“Oracle Database Appliance X6-2-HA Front and Back Panels” on page 37](#)
- [“Oracle Database Appliance X5-2 Front and Back Panels” on page 44](#)
- [“Oracle Database Appliance X3-2/X4-2 Front and Back Panels” on page 51](#)
- [“Oracle Database Appliance Version 1 Front and Back Panels” on page 58](#)
- [“Oracle Database Appliance Specifications” on page 61](#)
- [“Technical Support” on page 68](#)

## Supported Components and Capabilities

The following sections describe the components and capabilities of the different versions of Oracle Database Appliance.

- [“Oracle Database Appliance X7-2 Series Components and Capabilities” on page 12](#)
- [“Oracle Database Appliance X6-2 Series Components and Capabilities” on page 14](#)
- [“Oracle Database Appliance Version 1 and Models X3-2, X4-2 and X5-2 Components and Capabilities” on page 18](#)

## Oracle Database Appliance X7-2 Series Components and Capabilities

The following table lists supported components and capabilities for the Oracle Database Appliance X7-2 series systems.

Component	Oracle Database Appliance X7-2S	Oracle Database Appliance X7-2M	Oracle Database Appliance X7-2-HA
Server node	Single 1RU server.	Single 1RU server.	Two 1RU server nodes. Each server node operates independently from the other server node. The lower server node is node 0 (SN0). The upper server node is node 1 (SN1).
CPUs	One 10-core 2.2 GHz Intel Xeon 4114 processor.	Two 18-core 2.3 GHz Intel Xeon 6140 processors.	Two 18-core 2.3 GHz Intel Xeon 6140 processors per server node.
Memory	192 GB – six 32 GB low-voltage DDR4 RDIMMs rated at 2667 MT/sec. <b>Note</b> - Optional memory expansion to 384 GB. See <a href="#">“Optional Component Installation” on page 74</a> .	384 GB – twelve 32 GB low-voltage DDR4 RDIMMs rated at 2667 MT/sec. <b>Note</b> - Optional memory expansion to 768 GB. See <a href="#">“Optional Component Installation” on page 74</a> .	384 GB – twelve 32 GB low-voltage DDR4 RDIMMs rated at 2667 MT/sec per server node. <b>Note</b> - Optional memory expansion to 768 GB per server. Both server nodes must have the same amount of memory. See <a href="#">“Optional Component Installation” on page 74</a> .
Storage devices	The server includes: <ul style="list-style-type: none"> <li>■ Two internal 480 GB M.2 SATA SSDs reserved for operating system storage and system booting</li> <li>■ Two 2.5-inch 6.4 TB NVMe SSDs in slots HDD 0-1</li> </ul>	The server includes: <ul style="list-style-type: none"> <li>■ Two internal 480 GB M.2 SATA SSDs reserved for operating system storage and system booting</li> <li>■ Two 2.5-inch 6.4 TB NVMe SSDs in slots HDD 0-1</li> </ul> <p><b>Note</b> - Up to six optional NVMe SSDs can be added.</p>	Each server node includes: <ul style="list-style-type: none"> <li>■ Two internal 480 GB M.2 SATA SSDs reserved for operating system storage and system booting</li> </ul> <p>The 4RU storage shelf includes:</p>



Component	Oracle Database Appliance X7-2S	Oracle Database Appliance X7-2M	Oracle Database Appliance X7-2-HA
		See <a href="#">“Optional Component Installation”</a> on page 74.	<ul style="list-style-type: none"> <li>■ Four 2.5-inch 800 GB high endurance SAS SSDs (in 3.5-inch mounting brackets) in slots 20-23</li> <li>■ Plus one of the following available configurations: <ul style="list-style-type: none"> <li>■ Five 2.5-inch 3.2 TB SAS SSDs (in 3.5-inch mounting brackets) in slots 0-4 and filler panels in slots 5-19</li> <li>■ Twenty 2.5-inch 3.2 TB SAS SSDs (in 3.5-inch mounting brackets) in slots 0-19</li> <li>■ Five 2.5-inch 3.2 TB SAS SSDs (in 3.5-inch mounting brackets) in slots 15-19 and fifteen 2.5-inch 10 TB SAS HDDs (in 3.5-inch mounting brackets) in slots 0-14</li> </ul> </li> </ul> <p><b>Note</b> - For a partially populated storage shelf, optional 3.2 TB SAS SSDs, or 10 TB SAS HDDs can be added. See <a href="#">“Optional Component Installation”</a> on page 74.</p>
USB 2.0 ports	Two total (one rear and one internal) per server node.	Two total (one rear and one internal) per server node.	Two total (one rear and one internal) per server node.
PCI Express (PCIe) I/O slots	Three external and one internal low-profile PCIe Gen-3 slots. These are shipped empty.	Three external and one internal low-profile PCIe Gen-3 slots. These are shipped empty.	Three external and one internal low-profile PCIe Gen-3 slots for each server node. They contain: <ul style="list-style-type: none"> <li>■ PCIe slot 1: Dual 25 GbE SFP28 PCIe 2.0 Low Profile Adapter</li> <li>■ PCIe slot 2: Dual-port External 12Gb/s SAS3 host bus adapter</li> <li>■ PCIe slot 3: Dual-port External 12Gb/s SAS3 host bus adapter</li> </ul>
Cluster device	N/A	N/A	One integrated cluster device with node-to-node interconnection is provided on each server node through two 10/25GbE ports with SFP28 connections.
SAS ports	Two internal SAS3 ports	Two internal SAS3 ports	Two internal SAS3 and four external SAS3 ports on each server node.  Six SAS3 ports on the storage shelf.  Six SAS3 ports on the storage expansion shelf.
Onboard Ethernet ports	One 10/100/1000Base-T network interface port with RJ-45 connector on each server node rear panel.	One 10/100/1000Base-T network interface port with RJ-45 connector on each server node rear panel.	One 10/100/1000Base-T network interface port with RJ-45 connector on each server node rear panel.

Component	Oracle Database Appliance X7-2S	Oracle Database Appliance X7-2M	Oracle Database Appliance X7-2-HA
Network management (NET MGT) port	Two 10/25GbE SFP28 ports, or two 10 GbE RJ-45 ports located on the back of each server node.  One 10/100/1000Base-T network interface port with RJ-45 connector dedicated to the service processor (SP) on each server node rear panel.	Two 10/25GbE SFP28 ports, or two 10 GbE RJ-45 ports located on the back of each server node.  One 10/100/1000Base-T network interface port with RJ-45 connector dedicated to the service processor (SP) on each server node rear panel.	Two 10/25GbE SFP28 ports, or two 10 GbE RJ-45 ports located on the back of each server node.  One 10/100/1000Base-T network interface port with RJ-45 connector dedicated to the service processor (SP) on each server node rear panel.
Serial management (SER MGT) port	One RS-232 RJ-45 serial port on each server node rear panel.	One RS-232 RJ-45 serial port on each server node rear panel.	One RS-232 RJ-45 serial port on each server node rear panel.
VGA port	N/A	N/A	N/A
Service Processor (SP)	Each server node has a service processor with the following features: <ul style="list-style-type: none"> <li>■ Includes the Baseboard Management Controller (BMC), which supports the industry-standard Intelligent Platform Management Interface (IPMI) feature set.</li> <li>■ Supports remote KVMS over IP.</li> <li>■ Supports Ethernet access to SP through a dedicated 10/100/1000Base-T management port and optionally through one of the host GbE ports (sideband management).</li> </ul>	Each server node has a service processor with the following features: <ul style="list-style-type: none"> <li>■ Includes the Baseboard Management Controller (BMC), which supports the industry-standard Intelligent Platform Management Interface (IPMI) feature set.</li> <li>■ Supports remote KVMS over IP.</li> <li>■ Supports Ethernet access to SP through a dedicated 10/100/1000Base-T management port and optionally through one of the host GbE ports (sideband management).</li> </ul>	Each server node has a service processor with the following features: <ul style="list-style-type: none"> <li>■ Includes the Baseboard Management Controller (BMC), which supports the industry-standard Intelligent Platform Management Interface (IPMI) feature set.</li> <li>■ Supports remote KVMS over IP.</li> <li>■ Supports Ethernet access to SP through a dedicated 10/100/1000Base-T management port and optionally through one of the host GbE ports (sideband management).</li> </ul>
Power supplies	Two hot-pluggable power supplies.	Two hot-pluggable power supplies.	Two hot-pluggable power supplies per server node and per storage shelf.
Cooling fans	Four 40-mm, hot-pluggable fan modules per server node for chassis cooling. Each fan module contains two counter-rotating fan pairs (four rotors total).  Each power supply has its own cooling fans.	Four 40-mm, hot-pluggable fan modules per server node for chassis cooling. Each fan module contains two counter-rotating fan pairs (four rotors total).  Each power supply has its own cooling fans.	Four 40-mm, hot-pluggable fan modules per server node for chassis cooling. Each fan module contains two counter-rotating fan pairs (four rotors total).  Each power supply (server node and storage shelf) has its own cooling fans.
Operating system	Oracle Linux.	Oracle Linux.	Oracle Linux.
Management software	Oracle Integrated Lights Out Manager (ILOM) 4.0.	Oracle Integrated Lights Out Manager (ILOM) 4.0.	Oracle Integrated Lights Out Manager (ILOM) 4.0.

## Oracle Database Appliance X6-2 Series Components and Capabilities

The following table lists supported components and capabilities for the Oracle Database Appliance X6-2 series systems.

Component	Oracle Database Appliance X6-2S	Oracle Database Appliance X6-2M	Oracle Database Appliance X6-2L	Oracle Database Appliance X6-2-HA
Server node	Single 1RU server.	Single 1RU server.	Single 2RU server.	Two 1RU server nodes. Each server node operates independently from the other server node. The lower server node is node 0 (SN0). The upper server node is node 1 (SN1).
CPUs	One 10-core 2.2 GHz Intel Xeon E5-2630 V4 processor.	Two 10-core 2.2 GHz Intel Xeon E5-2630 V4 processors.	Two 10-core 2.2 GHz Intel Xeon E5-2630 V4 processors.	Two 10-core 2.2 GHz Intel Xeon E5-2630 V4 processors per server node.
Memory	128 GB – four 32 GB low-voltage DDR4 RDIMMs rated at 2400 MT/s (2133 MT/s actual maximum). <b>Note</b> - Optional memory expansion to 384 GB. See <a href="#">“Optional Component Installation” on page 74.</a>	256 GB – eight 32 GB low-voltage DDR4 RDIMMs rated at 2400 MT/s (2133 MT/s actual maximum). <b>Note</b> - Optional memory expansion to 512 GB or 768 GB. See <a href="#">“Optional Component Installation” on page 74.</a>	256 GB – eight 32 GB low-voltage DDR4 RDIMMs rated at 2400 MT/s (2133 MT/s actual maximum). <b>Note</b> - Optional memory expansion to 512 GB or 768 GB. See <a href="#">“Optional Component Installation” on page 74.</a>	256 GB – eight 32 GB low-voltage DDR4 RDIMMs rated at 2400 MT/s per server node (2133 MT/s actual maximum). <b>Note</b> - Optional memory expansion to 512 GB or 768 GB per server. Both server nodes must have the same amount of memory. See <a href="#">“Optional Component Installation” on page 74.</a>
Storage devices	The server includes: <ul style="list-style-type: none"> <li>■ Two 2.5-inch 480 GB SATA SSDs in slots HDD 0-1 reserved for operating system storage and system booting</li> <li>■ Two 2.5-inch 3.2 TB NVMe SSDs in slots NVMe 0-1</li> </ul> <b>Note</b> - Two optional NVMe SSDs can be added. See	The server includes: <ul style="list-style-type: none"> <li>■ Two 2.5-inch 480 GB SATA SSDs in slots HDD 0-1 reserved for operating system storage and system booting</li> <li>■ Two 2.5-inch 3.2 TB NVMe SSDs in slots NVMe 0-1</li> </ul> <b>Note</b> - Two optional NVMe SSDs can be added. See	The server includes: <ul style="list-style-type: none"> <li>■ Six 2.5-inch 3.2 TB NVMe SSDs in front slots 0, 1, 3, 4, 6, 7</li> </ul> <b>Note</b> - Three optional NVMe SSDs can be added. See <a href="#">“Optional Component Installation” on page 74.</a> <ul style="list-style-type: none"> <li>■ Two 2.5-inch 480 GB SATA SSDs in rear</li> </ul>	Each server node includes: <ul style="list-style-type: none"> <li>■ Two 2.5-inch 480 GB SATA SSDs in slots 0-1 reserved for operating system storage and system booting</li> </ul> The 4RU storage shelf and the optional storage expansion shelf each include:

Supported Components and Capabilities

Component	Oracle Database Appliance X6-2S	Oracle Database Appliance X6-2M	Oracle Database Appliance X6-2L	Oracle Database Appliance X6-2-HA
	<a href="#">“Optional Component Installation” on page 74.</a>	<a href="#">“Optional Component Installation” on page 74.</a>	slots 0-1 reserved for operating system storage and system booting	<ul style="list-style-type: none"> <li>■ Ten 2.5-inch 1.6 TB SAS SSDs (in 3.5-inch mounting brackets) in slots 0-9</li> <li>■ Base storage shelf configuration: Filler panels in slots 10-19</li> </ul> <p>Full storage shelf or standard storage expansion shelf configuration: Ten 2.5-inch 1.6 TB SAS SSDs (in 3.5-inch mounting brackets) in slots 10-19</p> <p><b>Note</b> - Optional 1.6 TB SAS SSDs can be added to these slots. See <a href="#">“Optional Component Installation” on page 74.</a></p> <ul style="list-style-type: none"> <li>■ Four 2.5-inch 200 GB high endurance SAS SSDs (in 3.5-inch mounting brackets) in slots 20-23</li> </ul>
USB 2.0 ports	Six total (two front, two rear and two internal) per server node.	Six total (two front, two rear and two internal) per server node.	Six total (two front, two rear and two internal) per server node.	Six total (two front, two rear and two internal) per server node.
PCI Express (PCIe) I/O slots	<p>Three external and one internal low-profile PCIe Gen-3 slots. They contain:</p> <ul style="list-style-type: none"> <li>■ PCIe slot 2: NVMe Switch PCIe Card</li> <li>■ PCIe slot 3: Dual 10 GbE SFP+ PCIe 2.0 Low Profile Adapter</li> <li>■ PCIe slot 4: Dual-port Internal 12Gb/s SAS3 host bus adapter</li> </ul>	<p>Three external and one internal low-profile PCIe Gen-3 slots. They contain:</p> <ul style="list-style-type: none"> <li>■ PCIe slot 2: NVMe Switch PCIe Card</li> <li>■ PCIe slot 3: Dual 10 GbE SFP+ PCIe 2.0 Low Profile Adapter</li> <li>■ PCIe slot 4: Dual-port Internal 12Gb/s SAS3 host bus adapter</li> </ul>	<p>Six external internal low-profile PCIe Gen-3 slots. They contain:</p> <ul style="list-style-type: none"> <li>■ PCIe slot 1: Dual 10 GbE SFP+ PCIe 2.0 Low Profile Adapter</li> <li>■ PCIe slots 2, 5, 6: NVMe Switch PCIe Card</li> <li>■ PCIe slot 3: Dual-port Internal 12Gb/s SAS3 host bus adapter</li> </ul>	<p>Three external and one internal low-profile PCIe Gen-3 slots for each server node. They contain:</p> <ul style="list-style-type: none"> <li>■ PCIe slot 1: Dual Port QDR InfiniBand M3 PCIe 3.0 Low Profile Adapter</li> <li>--or--</li> <li>■ PCIe slot 1: Dual 10 GbE SFP+ PCIe 2.0 Low Profile Adapter</li> <li>■ PCIe slot 2: Dual-port External 12Gb/s SAS3 host bus adapter</li> <li>■ PCIe slot 3: Dual-port External 12Gb/s SAS3 host bus adapter</li> <li>■ PCIe slot 4: Dual-port Internal 12Gb/s SAS3 host bus adapter</li> </ul>
Cluster device	N/A	N/A	N/A	One integrated cluster device with node-to-node interconnection is provided

Component	Oracle Database Appliance X6-2S	Oracle Database Appliance X6-2M	Oracle Database Appliance X6-2L	Oracle Database Appliance X6-2-HA
				<p>on each server node through two InfiniBand ports with QSFP+ connections.</p> <p>Alternatively, you have the option of creating the node-to-node interconnection using two of each server node's four 10 GbE network interface ports with RJ-45 connections.</p> <p><b>Note</b> - This alternative configuration is used when the Oracle Database Appliance X6-2-HA is ordered with a Dual 10GbE SFP+ PCIe 2.0 Low Profile Adapter instead of the standard InfiniBand adapter when an Ethernet fiber connection to the data center or public network is required.</p>
SAS ports	Two internal SAS3 ports	Two internal SAS3 ports	Two internal SAS3 ports (only one used for rear drives)	<p>Two internal SAS3 and four external SAS3 ports on each server node.</p> <p>Six SAS3 ports on the storage shelf.</p> <p>Six SAS3 ports on the storage expansion shelf.</p>
Onboard Ethernet ports	Two functional auto-sensing 100/1000/10000 Base-T Ethernet ports with RJ-45 connectors located on the back of the server. <b>Note</b> - Ethernet ports NET 2 and NET 3 are nonfunctional in single-processor systems.	Four auto-sensing 100/1000/10000 Base-T Ethernet ports with RJ-45 connectors located on the back of the server.	Four auto-sensing 100/1000/10000 Base-T Ethernet ports with RJ-45 connectors located on the back of the server.	Four auto-sensing 100/1000/10000 Base-T Ethernet ports with RJ-45 connectors located on the back of each server node.
Network management (NET MGT) port	One 10/100/1000Base-T network interface port with RJ-45 connector dedicated to the service processor (SP) on each server node rear panel.	One 10/100/1000Base-T network interface port with RJ-45 connector dedicated to the service processor (SP) on each server node rear panel.	One 10/100/1000Base-T network interface port with RJ-45 connector dedicated to the service processor (SP) on each server node rear panel.	One 10/100/1000Base-T network interface port with RJ-45 connector dedicated to the service processor (SP) on each server node rear panel.
Serial management (SER MGT) port	One RS-232 RJ-45 serial port on each server node rear panel.	One RS-232 RJ-45 serial port on each server node rear panel.	One RS-232 RJ-45 serial port on each server node rear panel.	One RS-232 RJ-45 serial port on each server node rear panel.
VGA port	One high-density HD-15 video port on each server node rear panel.	One high-density HD-15 video port on each server node rear panel.	One high-density HD-15 video port on each server node rear panel.	One high-density HD-15 video port on each server node rear panel.

Component	Oracle Database Appliance X6-2S	Oracle Database Appliance X6-2M	Oracle Database Appliance X6-2L	Oracle Database Appliance X6-2-HA
Service Processor (SP)	<p>Each server node has a service processor with the following features:</p> <ul style="list-style-type: none"> <li>■ Includes the Baseboard Management Controller (BMC), which supports the industry-standard Intelligent Platform Management Interface (IPMI) feature set.</li> <li>■ Supports remote KVMS over IP.</li> <li>■ Supports Ethernet access to SP through a dedicated 10/100/1000Base-T management port and optionally through one of the host GbE ports (sideband management).</li> </ul>	<p>Each server node has a service processor with the following features:</p> <ul style="list-style-type: none"> <li>■ Includes the Baseboard Management Controller (BMC), which supports the industry-standard Intelligent Platform Management Interface (IPMI) feature set.</li> <li>■ Supports remote KVMS over IP.</li> <li>■ Supports Ethernet access to SP through a dedicated 10/100/1000Base-T management port and optionally through one of the host GbE ports (sideband management).</li> </ul>	<p>Each server node has a service processor with the following features:</p> <ul style="list-style-type: none"> <li>■ Includes the Baseboard Management Controller (BMC), which supports the industry-standard Intelligent Platform Management Interface (IPMI) feature set.</li> <li>■ Supports remote KVMS over IP.</li> <li>■ Supports Ethernet access to SP through a dedicated 10/100/1000Base-T management port and optionally through one of the host GbE ports (sideband management).</li> </ul>	<p>Each server node has a service processor with the following features:</p> <ul style="list-style-type: none"> <li>■ Includes the Baseboard Management Controller (BMC), which supports the industry-standard Intelligent Platform Management Interface (IPMI) feature set.</li> <li>■ Supports remote KVMS over IP.</li> <li>■ Supports Ethernet access to SP through a dedicated 10/100/1000Base-T management port and optionally through one of the host GbE ports (sideband management).</li> </ul>
Power supplies	Two hot-pluggable power supplies.	Two hot-pluggable power supplies.	Two hot-pluggable power supplies.	Two hot-pluggable power supplies per server node and per storage shelf.
Cooling fans	<p>Four 40-mm, hot-pluggable fan modules per server node for chassis cooling. Each fan module contains two counter-rotating fan pairs (four rotors total).</p> <p>Each power supply has its own cooling fans.</p>	<p>Four 40-mm, hot-pluggable fan modules per server node for chassis cooling. Each fan module contains two counter-rotating fan pairs (four rotors total).</p> <p>Each power supply has its own cooling fans.</p>	<p>Four 80-mm, hot-pluggable fan modules per server node for chassis cooling. Each fan module contains two counter-rotating fan pairs (four rotors total).</p> <p>Each power supply has its own cooling fans.</p>	<p>Four 40-mm, hot-pluggable fan modules per server node for chassis cooling. Each fan module contains two counter-rotating fan pairs (four rotors total).</p> <p>Each power supply (server node and storage shelf) has its own cooling fans.</p>
Operating system	Oracle Linux.	Oracle Linux.	Oracle Linux.	Oracle Linux.
Management software	Oracle Integrated Lights Out Manager (ILOM) 3.2.	Oracle Integrated Lights Out Manager (ILOM) 3.2.	Oracle Integrated Lights Out Manager (ILOM) 3.2.	Oracle Integrated Lights Out Manager (ILOM) 3.2.

## Oracle Database Appliance Version 1 and Models X3-2, X4-2 and X5-2 Components and Capabilities

The following table lists supported components and capabilities for the Oracle Database Appliance Version 1, Oracle Database Appliance X3-2, Oracle Database Appliance X4-2 and Oracle Database Appliance X5-2.

Component	Oracle Database Appliance (Version 1)	Oracle Database Appliance X3-2	Oracle Database Appliance X4-2	Oracle Database Appliance X5-2
Server node	Two server nodes per chassis. Each server node operates independently from the other server node. The lower server node is node 0 (SN0). The upper server node is node 1 (SN1).	Two server nodes. Each server node operates independently from the other server node. The lower server node is node 0 (SN0). The upper server node is node 1 (SN1).	Two server nodes. Each server node operates independently from the other server node. The lower server node is node 0 (SN0). The upper server node is node 1 (SN1).	Two server nodes. Each server node operates independently from the other server node. The lower server node is node 0 (SN0). The upper server node is node 1 (SN1).
CPUs	Two 6-core 3.06 GHz Intel Xeon X5675 processors per server node.	Two 8-core 2.9 GHz Intel Xeon E5-2690 processors per server node.	Two 12-core 2.7 GHz Intel Xeon E5-2697 v2 processors per server node.	Two 18-core 2.3 GHz Intel Xeon E5-2699 v3 processors per server node.
Memory	96 GB – six 8 GB low-voltage DDR3 RDIMMs (single or dual rank) at 1333 MT/s per server node. <b>Note</b> - Quad-rank DIMMs are not supported.	256 GB – sixteen 16 GB low-voltage DDR3 RDIMMs at 1600 MT/s per server node.	256 GB – sixteen 16 GB low-voltage DDR3 RDIMMs at 1600 MT/s per server node.	256 GB – eight 32 GB low-voltage DDR4 LRDIMMs at 2133 MT/s per server node. <b>Note</b> - Optional memory expansion to 512 GB or 768 GB. Both server nodes must have the same amount of memory. See <a href="#">“Optional Component Installation” on page 74.</a>
Storage devices	Each server node includes: <ul style="list-style-type: none"> <li>■ Twenty 3.5-inch SAS 600-GB HDDs in slots 0-19</li> <li>■ Four 3.5-inch SAS 73-GB SSDs in slots 20-23</li> <li>■ Two rear accessed, 2.5-inch SATA 500 GB HDDs reserved for operating system storage and system booting</li> <li>■ One internal 4 GB USB thumb drive</li> </ul>	Each server node includes: <ul style="list-style-type: none"> <li>■ Two 2.5-inch 600 GB SAS2 HDDs reserved for operating system storage and system booting</li> </ul> <p>The storage shelf and the optional storage expansion shelf each include:</p> <ul style="list-style-type: none"> <li>■ Twenty 2.5-inch 900 GB SAS2 HDDs in slots 0-19</li> <li>■ Four 2.5-inch 200 GB SAS SSDs in slots 20-23</li> </ul>	Each server node includes: <ul style="list-style-type: none"> <li>■ Two 2.5-inch 600 GB SAS2 HDDs reserved for operating system storage and system booting</li> <li>■ One internal 4 or 8 GB USB thumb drive (reserved for future use)</li> </ul> <p>The storage shelf and the optional storage expansion shelf each include:</p> <ul style="list-style-type: none"> <li>■ Twenty 2.5-inch 900 GB SAS2 HDDs in slots 0-19</li> <li>■ Four 2.5 inch 200 GB SAS SSDs in slots 20-23</li> </ul>	Each server node includes: <ul style="list-style-type: none"> <li>■ Two 2.5-inch 600 GB SAS2 HDDs reserved for operating system storage and system booting</li> <li>■ One internal 8 GB USB thumb drive (reserved for future use)</li> </ul> <p>The storage shelf and the optional storage expansion shelf each include:</p> <ul style="list-style-type: none"> <li>■ Sixteen 3.5-inch 4 TB or 8 TB SAS2 HDDs in slots 0-15</li> <li>■ Four 2.5-inch 400 GB medium endurance SAS SSDs in slots 16-19</li> <li>■ Four 2.5-inch 200 GB high endurance SAS SSDs in slots 20-23</li> </ul>
USB 2.0 ports	Two rear and one internal for each server node.	Six total (two front, two rear and two internal) per server node.	Six total (two front, two rear and two internal) per server node.	Six total (two front, two rear and two internal) per server node.
PCI Express (PCIe) I/O slots	Three external low-profile PCIe Gen-2 slots (x8) for each server node. They contain:	Three external and one internal low-profile PCIe Gen-3 slots for each server node. They contain:	Three external and one internal low-profile PCIe Gen-3 slots for each server node. They contain:	Three external and one internal low-profile PCIe Gen-3 slots for each server node. They contain: <ul style="list-style-type: none"> <li>■ PCIe slot 1: Dual Port QDR InfiniBand M3</li> </ul>

Component	Oracle Database Appliance (Version 1)	Oracle Database Appliance X3-2	Oracle Database Appliance X4-2	Oracle Database Appliance X5-2
	<ul style="list-style-type: none"> <li>■ PCIe slot 0: Dual 10 GbE SFP+ PCIe 2.0 Low Profile Adapter</li> <li>■ PCIe slot 1: Quad-port 1 GbE (Gigabit Ethernet) Network Adapter with RJ-45 connectors</li> <li>■ PCIe slot 2: Dual-port External 6Gb/s SAS2 host bus adapter</li> </ul> <p>One internal low-profile PCIe Gen-2 slot (x8) with a Dual-port Internal 6Gb/s SAS2 host bus adapter</p>	<ul style="list-style-type: none"> <li>■ PCIe slot 1: Dual-port 10 GbE Network Adapter with RJ-45 connectors</li> <li>■ PCIe slot 2: Dual-port External 6Gb/s SAS2 host bus adapter</li> <li>■ PCIe slot 3: Dual-port External 6Gb/s SAS2 host bus adapter</li> <li>■ PCIe Slot 4: Dual-port Internal 6Gb/s SAS2 host bus adapter</li> </ul>	<ul style="list-style-type: none"> <li>■ PCIe slot 1: Dual 10 GbE SFP+ PCIe 2.0 Low Profile Adapter</li> <li>■ PCIe slot 2: Dual-port External 6Gb/s SAS2 host bus adapter</li> <li>■ PCIe slot 3: Dual-port External 6Gb/s SAS2 host bus adapter</li> <li>■ PCIe slot 4: Dual-port Internal 6Gb/s SAS2 host bus adapter</li> </ul>	<p>PCIe 3.0 Low Profile Adapter</p> <ul style="list-style-type: none"> <li>■ PCIe slot 2: Dual-port External 12Gb/s SAS3 host bus adapter</li> <li>■ PCIe slot 3: Dual-port External 12Gb/s SAS3 host bus adapter</li> <li>■ PCIe slot 4: Dual-port Internal 12Gb/s SAS3 host bus adapter</li> </ul>
Cluster device	One integrated cluster device with node-to-node connections is provided on each server node. Each integrated cluster device provides two internal 1 GbE network interface ports and two internal dual-port UART ports.	One integrated cluster device with node-to-node interconnection is provided on each server node through two 10 GbE network interface ports with RJ-45 connections.	One integrated cluster device with node-to-node interconnection is provided on each server node through two 10 GbE network interface ports with dual-rate SFP+ connections.  Alternatively, you have the option of creating the node-to-node interconnection using two of each server node's four 10 GbE network interface ports with RJ-45 connections. Refer to the <i>Oracle Database Appliance Getting Started Guide</i> for more information.	One integrated cluster device with node-to-node interconnection is provided on each server node through two InfiniBand ports with QSFP+ connections.  Alternatively, you have the option of creating the node-to-node interconnection using two of each server node's four 10 GbE network interface ports with RJ-45 connections. Refer to the <i>Oracle Database Appliance Getting Started Guide</i> for more information.
SAS ports	N/A	Two internal SAS2 and four external SAS2 ports on each server node.  Six SAS2 ports on the storage shelf.  Six SAS2 ports on the storage expansion shelf.	Two internal SAS2 and four external SAS2 ports on each server node.  Six SAS2 ports on the storage shelf.  Six SAS2 ports on the storage expansion shelf.	Two internal SAS3 and four external SAS3 ports on each server node.  Six SAS2 ports on the storage shelf.  Six SAS2 ports on the storage expansion shelf.
Onboard Ethernet ports	Two 1 GbE network interface ports with RJ-45 connectors located on the back panel of each server node.	Four auto-sensing 100/1000/10000 Base-T Ethernet ports with RJ-45 connectors located on the back of each server node.	Four auto-sensing 100/1000/10000 Base-T Ethernet ports with RJ-45 connectors located on the back of each server node.	Four auto-sensing 100/1000/10000 Base-T Ethernet ports with RJ-45 connectors located on the back of each server node.  <b>Note</b> - Optionally, you can purchase the Sun Dual 10GbE SFP+ PCIe 2.0 Low Profile Adapter as a replacement for the standard InfiniBand adapter if an Ethernet fiber connection



Component	Oracle Database Appliance (Version 1)	Oracle Database Appliance X3-2	Oracle Database Appliance X4-2	Oracle Database Appliance X5-2
				to the data center or public network is required. See <a href="#">“Optional Component Installation” on page 74.</a>
Network management (NET MGT) port	One 10/100Base-T network interface port with RJ-45 connector dedicated to the service processor (SP) on the back panel of each server node.	One 10/100Base-T network interface port with RJ-45 connector dedicated to the service processor (SP) on the back panel of each server node.	One 10/100Base-T network interface port with RJ-45 connector dedicated to the service processor (SP) on the back panel of each server node.	One 10/100/1000Base-T network interface port with RJ-45 connector dedicated to the service processor (SP) on the back panel of each server node.
Serial management (SER MGT) port	One RS-232 RJ-45 serial port on the back panel of each server node.	One RS-232 RJ-45 serial port on the back panel of each server node.	One RS-232 RJ-45 serial port on the back panel of each server node.	One RS-232 RJ-45 serial port on the back panel of each server node.
VGA port	One high-density HD-15 video port on the back panel of each server node.	One high-density HD-15 video port on the back panel of each server node.	One high-density HD-15 video port on the back panel of each server node.	One high-density HD-15 video port on the back panel of each server node.
Service Processor (SP)	Each server node has a service processor with the following features: <ul style="list-style-type: none"> <li>■ Includes the Baseboard Management Controller (BMC), which supports the industry-standard Intelligent Platform Management Interface (IPMI) feature set.</li> <li>■ Supports remote KVMs over IP.</li> <li>■ Supports Ethernet access to SP through a dedicated 10/100Base-T management port and optionally through one of the host GbE ports (sideband management)</li> </ul>	Each server node has a service processor with the following features: <ul style="list-style-type: none"> <li>■ Includes the Baseboard Management Controller (BMC), which supports the industry-standard Intelligent Platform Management Interface (IPMI) feature set.</li> <li>■ Supports remote KVMs over IP.</li> <li>■ Supports Ethernet access to SP through a dedicated 10/100Base-T management port and optionally through one of the host GbE ports (sideband management).</li> </ul>	Each server node has a service processor with the following features: <ul style="list-style-type: none"> <li>■ Includes the Baseboard Management Controller (BMC), which supports the industry-standard Intelligent Platform Management Interface (IPMI) feature set.</li> <li>■ Supports remote KVMs over IP.</li> <li>■ Supports Ethernet access to SP through a dedicated 10/100Base-T management port and optionally through one of the host GbE ports (sideband management).</li> </ul>	Each server node has a service processor with the following features: <ul style="list-style-type: none"> <li>■ Includes the Baseboard Management Controller (BMC), which supports the industry-standard Intelligent Platform Management Interface (IPMI) feature set.</li> <li>■ Supports remote KVMs over IP.</li> <li>■ Supports Ethernet access to SP through a dedicated 10/100/1000Base-T management port and optionally through one of the host GbE ports (sideband management).</li> </ul>
Power supplies	Two hot-pluggable power supplies per chassis.	Two hot-pluggable power supplies per server node and per storage shelf.	Two hot-pluggable power supplies per server node and per storage shelf.	Two hot-pluggable power supplies per server node and per storage shelf.
Cooling fans	Two redundant hot-pluggable fan modules per server node.	Four 40-mm, hot-pluggable fan modules per server node for chassis cooling. Each fan module contains two counter-rotating fan pairs (four rotors total).  Each power supply (server node and storage shelf) has its own cooling fans.	Four 40-mm, hot-pluggable fan modules per server node for chassis cooling. Each fan module contains two counter-rotating fan pairs (four rotors total).  Each power supply (server node and storage shelf) has its own cooling fans.	Four 40-mm, hot-pluggable fan modules per server node for chassis cooling. Each fan module contains two counter-rotating fan pairs (four rotors total).  Each power supply (server node and storage shelf) has its own cooling fans.

Component	Oracle Database Appliance (Version 1)	Oracle Database Appliance X3-2	Oracle Database Appliance X4-2	Oracle Database Appliance X5-2
Operating system	Oracle Linux.	Oracle Linux.	Oracle Linux.	Oracle Linux.
Management software	Oracle Integrated Lights Out Manager (ILOM) 3.0.	Oracle Integrated Lights Out Manager (ILOM) 3.1.	Oracle Integrated Lights Out Manager (ILOM) 3.1.	Oracle Integrated Lights Out Manager (ILOM) 3.2.

## Oracle Database Appliance X7-2S/X7-2M Front and Back Panels

This section describes Oracle Database Appliance X7-2S/X7-2M front and back panels.

If you have Oracle Database Appliance X7-2-HA, see [“Oracle Database Appliance X7-2-HA Front and Back Panels” on page 25](#). If you have Oracle Database Appliance X6-2S/X6-2M/X6-2L, see [“Oracle Database Appliance X6-2S/X6-2M/X6-2L Front and Back Panels” on page 32](#). If you have Oracle Database Appliance X6-2-HA, see [“Oracle Database Appliance X6-2-HA Front and Back Panels” on page 37](#). If you have Oracle Database Appliance X5-2, see [“Oracle Database Appliance X5-2 Front and Back Panels” on page 44](#). If you have Oracle Database Appliance X3-2/X4-2, see [“Oracle Database Appliance X3-2/X4-2 Front and Back Panels” on page 51](#). If you have Oracle Database Appliance Version 1, see [“Oracle Database Appliance Version 1 Front and Back Panels” on page 58](#).

- [“Oracle Database Appliance X7-2S/X7-2M Front Panel” on page 22](#)
- [“Oracle Database Appliance X7-2S/X7-2M Back Panel” on page 23](#)

## Oracle Database Appliance X7-2S/X7-2M Front Panel

Oracle Database Appliance X7-2S and Oracle Database Appliance X7-2M servers each occupy 1RU.

The following figure shows the components on the front panel of an **Oracle Database Appliance X7-2S/X7-2M**.

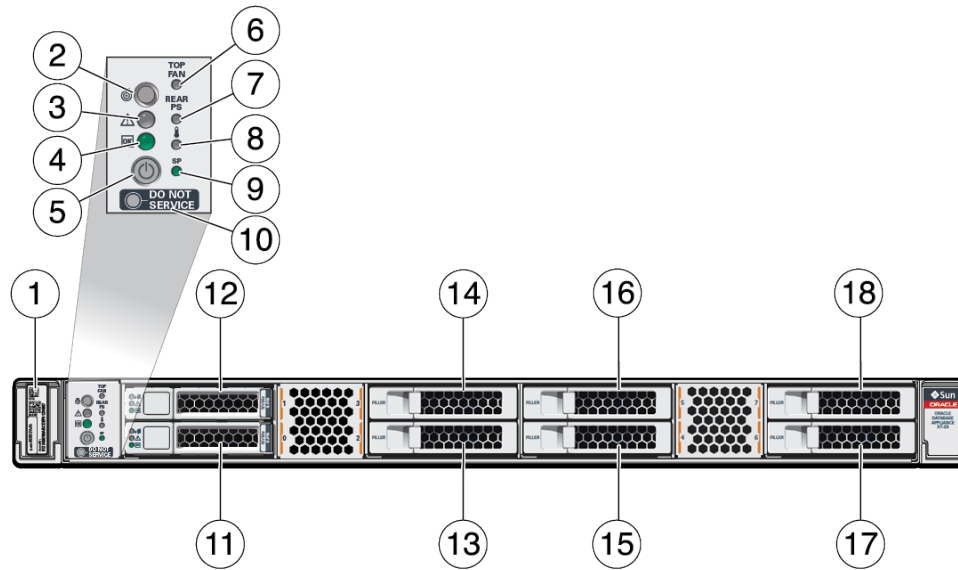

Callout	Description	Callout	Description
1	Product Serial Number (PSN) label and Radio Frequency Identification (RFID) tag	7	Power Supply (PS) Fault LED: amber
2	Locate LED/button: white	8	System Over Temperature Warning LED: amber
3	Service Required LED: amber	9	SP OK LED: green
4	Power/OK LED: green	10	DO NOT SERVICE
5	Power button	11 - 12	NVMe0, NVMe1
6	Fan Fault LED: amber	13 - 18	HDD filler

## Oracle Database Appliance X7-2S/X7-2M Back Panel

The following figure shows the components on the back panel of an **Oracle Database Appliance X7-2S/X7-2M**.

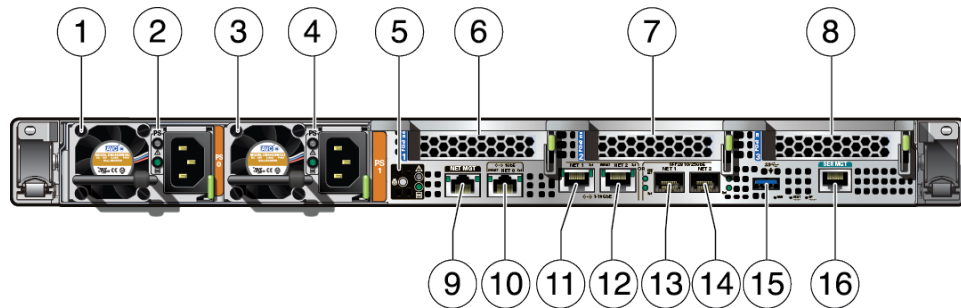

Callout	Description	Callout	Description
1	Power Supply (PS) 0 with fan module	9	NET MGT port. Service processor 10/100/1000Base-T network interface port with RJ-45 connector used to connect to Oracle Integrated Lights Out Manager (ILOM) <b>Caution</b> - The management ports are intended for use by service engineers only.
2	Power Supply (PS) 0 status indicators: Service Required LED: amber, AC OK LED: green	10	1 GbE RJ-45 network interface port: NET 0
3	Power Supply (PS) 1 with fan module	11	1/10 GbE RJ-45 network interface port: NET 1 <b>Note</b> - The system can be configured to use <b>either</b> the 10 GbE RJ-45 network ports or the 10/25 GbE SFP28 ports.
4	Power Supply (PS) 1 status indicators: Service Required LED: amber, AC OK LED: green	12	1/10 GbE RJ-45 network interface port: NET 2 <b>Note</b> - The system can be configured to use <b>either</b> the 10 GbE RJ-45 network ports or the 10/25 GbE SFP28 ports.
5	System status indicators: Locate LED: white, Service Required LED: amber, Power/OK LED: green	13	10/25 GbE SFP28 network interface port: NET 1 <b>Note</b> - The system can be configured to use <b>either</b> the 10 GbE RJ-45 network ports or the 10/25 GbE SFP28 ports.
6	PCIe card slot 1: empty	14	10/25 GbE SFP28 network interface port: NET 2 <b>Note</b> - The system can be configured to use <b>either</b> the 10 GbE RJ-45 network ports or the 10/25 GbE SFP28 ports.
7	PCIe card slot 1: empty	15	USB 2.0 connector
8	PCIe card slot 1: empty	16	SER MGT port. Service processor RJ-45 serial port used to connect to Oracle ILOM

Callout	Description	Callout	Description
	PCIe card slot 4 (internal): empty.		<b>Caution</b> - The management ports are intended for use by service engineers only.

## Oracle Database Appliance X7-2-HA Front and Back Panels

This section describes Oracle Database Appliance X7-2-HA front and back panels.

If you have Oracle Database Appliance X7-2S/X7-2M, see [“Oracle Database Appliance X7-2S/X7-2M Front and Back Panels” on page 22](#). If you have Oracle Database Appliance X6-2S/X6-2M/X6-2L, see [“Oracle Database Appliance X6-2S/X6-2M/X6-2L Front and Back Panels” on page 32](#). If you have Oracle Database Appliance X6-2-HA, see [“Oracle Database Appliance X6-2-HA Front and Back Panels” on page 37](#). If you have Oracle Database Appliance X5-2, see [“Oracle Database Appliance X5-2 Front and Back Panels” on page 44](#). If you have Oracle Database Appliance X3-2/X4-2, see [“Oracle Database Appliance X3-2/X4-2 Front and Back Panels” on page 51](#). If you have Oracle Database Appliance Version 1, see [“Oracle Database Appliance Version 1 Front and Back Panels” on page 58](#).

- [“Oracle Database Appliance X7-2-HA Front Panel” on page 25](#)
- [“Oracle Database Appliance X7-2-HA Back Panel” on page 29](#)

## Oracle Database Appliance X7-2-HA Front Panel

Oracle Database Appliance X7-2-HA includes two server nodes (two Oracle Server X7-2's) and an Oracle DE3-24C storage shelf. The entire unit occupies 6RU. The optional storage expansion shelf requires an additional 4RU, increasing the total to 10RU.

The following figure shows the front of Oracle Database Appliance X7-2-HA with an optional storage expansion shelf.

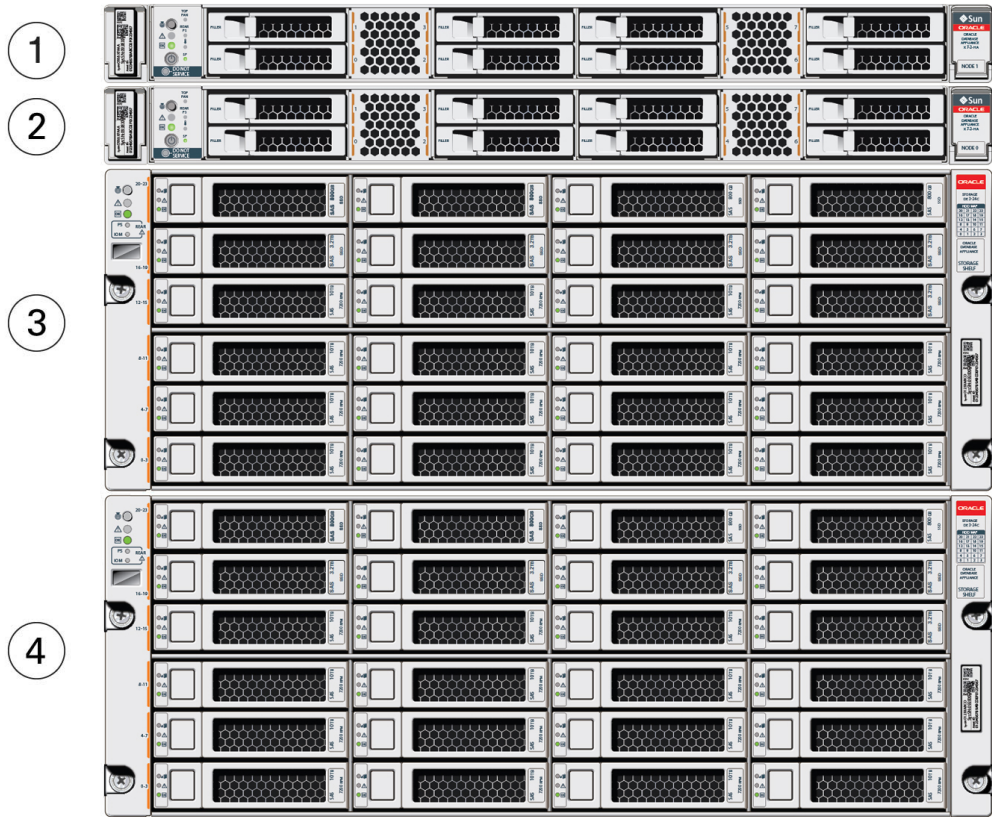

Callout	Description
1	Server node 1
2	Server node 0
3	Storage shelf (DE3-24C)
4	Optional storage expansion shelf (DE3-24C)

## Server Node Front Panel Features

The following figure shows the components on the front panel of an **Oracle Database Appliance X7-2-HA server node**.

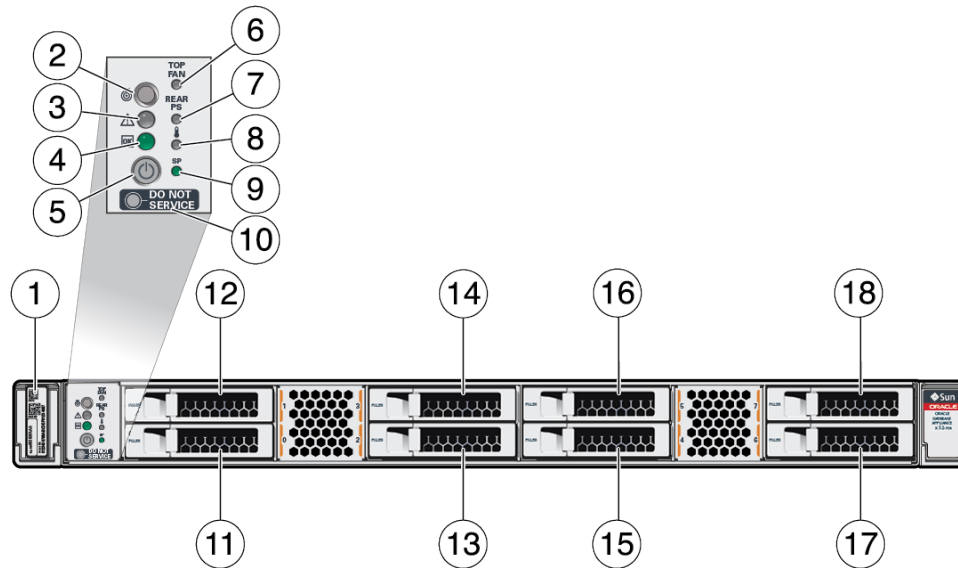

Callout	Description	Callout	Description
1	Product Serial Number (PSN) label and Radio Frequency Identification (RFID) tag	7	Power Supply (PS) Fault LED: amber
2	Locate LED/button: white	8	System Over Temperature Warning LED: amber
3	Service Required LED: amber	9	SP OK LED: green
4	Power/OK LED: green	10	DO NOT SERVICE
5	Power button	11 - 18	HDD/SSD 0 -7 (HDD filler)
6	Fan Fault LED: amber	NA	NA

**Note** - When contacting Oracle Support Services, use the Top Level Identifier (TLI) instead of the serial number. You can find the TLI by looking at the top of either server node or on the top of the storage shelf. For details, see [“Technical Support” on page 68](#).

## Storage Shelf Front Panel Features

The following figure shows the **Oracle Database Appliance X7-2-HA storage shelf** front panel features.

**Note** - There are three base configurations for the storage shelf: two fully populated and one partially populated (disk slots 5-19 are filler panels). Do not attempt to move or switch disks in the base configurations as it could cause the deployment to fail.

You have the option of upgrading the partially populated base configuration storage shelf to add disks to the empty slots. See [“Optional Component Installation” on page 74](#). Upgrading the base configuration to a fully populated storage shelf will allow you to add a storage expansion shelf later, if needed.

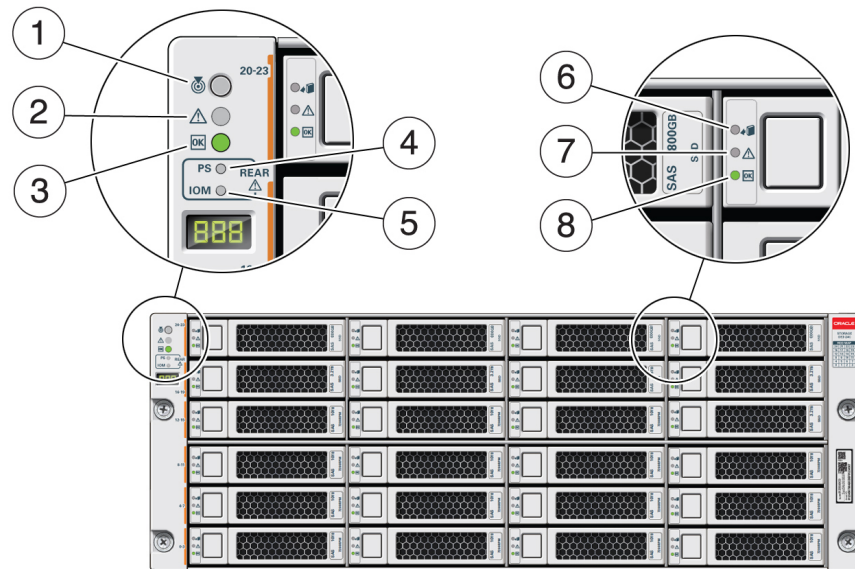

Callout	Description
1	Storage shelf Locate indicator
2	Storage shelf fault indicator
3	Storage shelf OK/power indicator
4	Storage shelf power supply fault indicator
5	Storage shelf IO module fault indicator
6	Drive Ready-to-Remove indicator
7	Drive fault indicator
8	Drive power/activity indicator



## Oracle Database Appliance X7-2-HA Back Panel

This section describes the back panel features for Oracle Database Appliance X7-2-HA. The following figure shows the back of Oracle Database Appliance X7-2-HA.

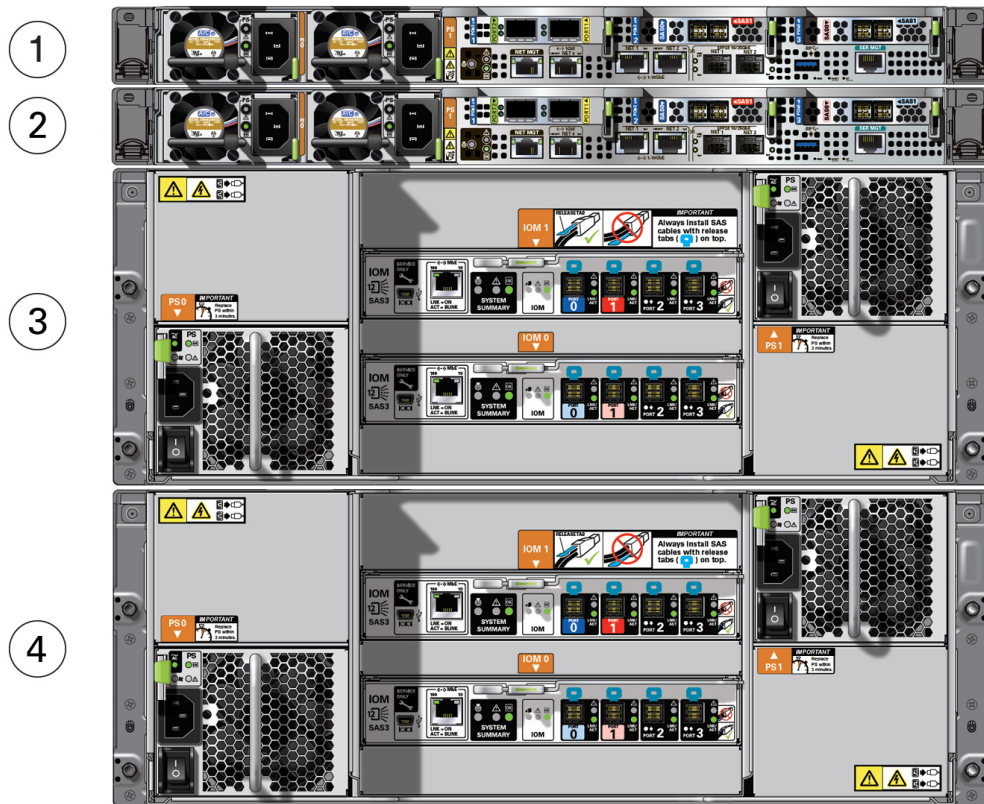

Callout	Description
1	Server node 1
2	Server node 0
3	Storage shelf (DE3-24C)
4	Optional storage expansion shelf (DE3-24C)

## Server Node Back Panel Features

The following figure shows the components on the **Oracle Database Appliance X7-2-HA server node** back panel.

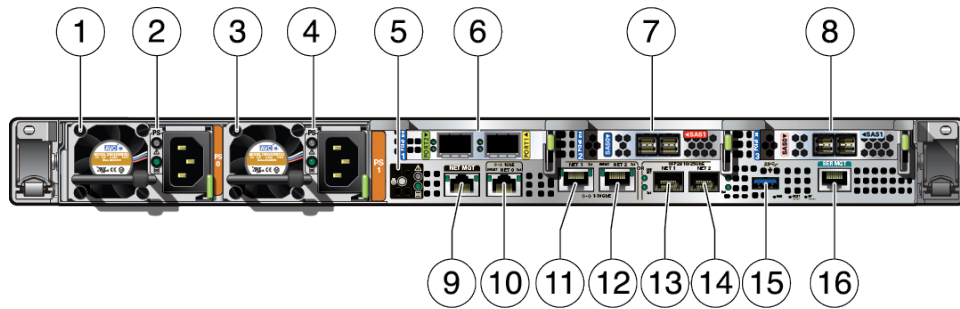

Callout	Description	Callout	Description
1	Power Supply (PS) 0 with fan module	9	NET MGT port. Service processor 10/100/1000Base-T network interface port with RJ-45 connector used to connect to Oracle Integrated Lights Out Manager (ILOM) <b>Caution</b> - The management ports are intended for use by service engineers only.
2	Power Supply (PS) 0 status indicators: Service Required LED: amber, AC OK LED: green	10	1 GbE RJ-45 network interface port: NET 0
3	Power Supply (PS) 1 with fan module	11	1/10 GbE RJ-45 network interface port: NET 1 <b>Note</b> - The system can be configured to use <b>either</b> the 10 GbE RJ-45 network ports or the 10/25 GbE SFP28 ports.
4	Power Supply (PS) 1 status indicators: Service Required LED: amber, AC OK LED: green	12	1/10 GbE RJ-45 network interface port: NET 2 <b>Note</b> - The system can be configured to use <b>either</b> the 10 GbE RJ-45 network ports or the 10/25 GbE SFP28 ports.
5	System status indicators: Locate LED: white, Service Required LED: amber, Power/OK LED: green	13	10/25 GbE SFP28 network interface port: NET 1 <b>Note</b> - The system can be configured to use <b>either</b> the 10 GbE RJ-45 network ports or the 10/25 GbE SFP28 ports.
6	PCIe card slot 1. Provides two 10/25GbE network interface ports with SFP28	14	10/25 GbE SFP28 network interface port: NET 2

Callout	Description	Callout	Description
	connections for a private cluster interconnect between server nodes.  --or--  Create the private cluster interconnect between the server nodes using two of each server node's two built-in 10 GbE network interface ports with RJ-45 connections. Refer to the <i>Deployment and User's Guide</i> for more information.		<b>Note</b> - The system can be configured to use <b>either</b> the 10 GbE RJ-45 network ports or the 10/25 GbE SFP28 ports.
7	PCIe card slot 2. Provides two SAS3 connectors used to connect the servers to the storage shelf and the storage expansion shelf.	15	USB 2.0 connector
8	PCIe card slot 3. Provides two SAS3 connectors used to connect the servers to the storage shelf and the storage expansion shelf.	16	SER MGT port. Service processor RJ-45 serial port used to connect to Oracle ILOM <b>Caution</b> - The management ports are intended for use by service engineers only.

## Storage Shelf Back Panel Features

The following figure shows the **Oracle Database Appliance X7-2-HA storage shelf** back panel features.



**Caution** - The network ports on the storage shelf are intended for use by service engineers only.

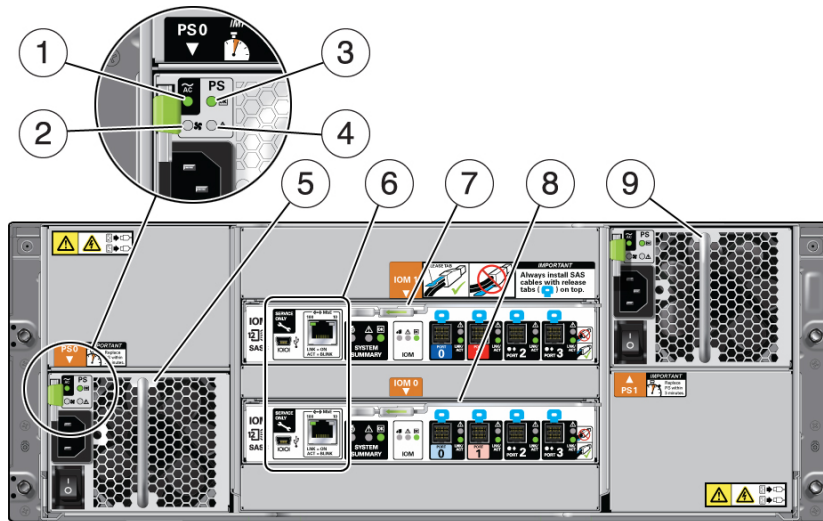

Callout	Description
1	AC power indicator
2	Fan fail indicator
3	Power supply status indicator
4	DC power fail indicator
5	Power Supply with Fan Module 0
6	Service ports (reserved for Oracle Service only)
7	SAS I/O module 1
8	SAS I/O module 0
9	Power Supply with Fan Module 1

## Oracle Database Appliance X6-2S/X6-2M/X6-2L Front and Back Panels

This section describes Oracle Database Appliance X6-2S/X6-2M/X6-2L front and back panels.

If you have Oracle Database Appliance X6-2-HA, see [“Oracle Database Appliance X6-2-HA Front and Back Panels” on page 37](#). If you have Oracle Database Appliance X7-2S/X7-2M, see [“Oracle Database Appliance X7-2S/X7-2M Front and Back Panels” on page 22](#). If you have Oracle Database Appliance X7-2-HA, see [“Oracle Database Appliance X7-2-HA Front and Back Panels” on page 25](#). If you have Oracle Database Appliance X5-2, see [“Oracle Database Appliance X5-2 Front and Back Panels” on page 44](#). If you have

Oracle Database Appliance X3-2/X4-2, see [“Oracle Database Appliance X3-2/X4-2 Front and Back Panels” on page 51](#). If you have Oracle Database Appliance Version 1, see [“Oracle Database Appliance Version 1 Front and Back Panels” on page 58](#).

- [“Oracle Database Appliance X6-2S/X6-2M Front Panel” on page 33](#)
- [“Oracle Database Appliance X6-2S/X6-2M Back Panel” on page 34](#)
- [“Oracle Database Appliance X6-2L Front Panel” on page 35](#)
- [“Oracle Database Appliance X6-2L Back Panel” on page 36](#)

## Oracle Database Appliance X6-2S/X6-2M Front Panel

Oracle Database Appliance X6-2S and Oracle Database Appliance X6-2M servers each occupy 1RU.

The following figure shows the components on the front panel of an **Oracle Database Appliance X6-2S/X6-2M**.

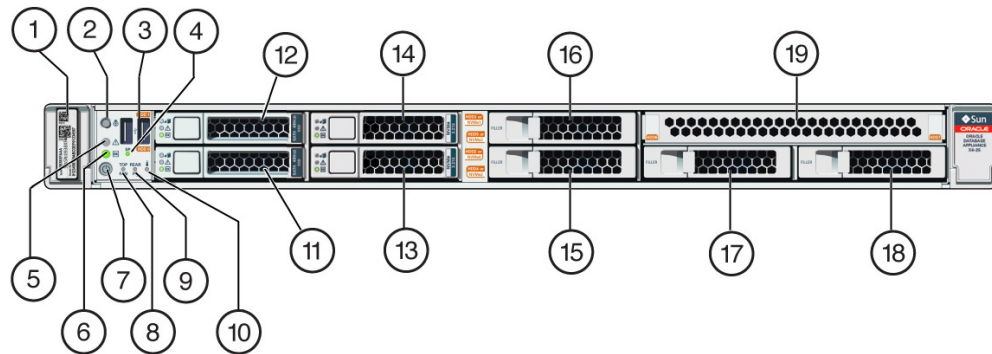

Callout	Description	Callout	Description
1	Product Serial Number (PSN) label and Radio Frequency Identification (RFID) tag	8	Fan Fault LED: amber
2	Locate LED/button: white	9	Power Supply (PS) Fault LED: amber
3	USB 2.0 connectors (2)	10	System Over Temperature Warning LED: amber
4	SP OK LED: green	11 - 12	HDD 0 - HDD 1 (boot drives)
5	Service Required LED: amber	13 - 16	NVMe0, NVMe1, NVMe2 (or HDD filler), NVMe3 (or HDD filler)
6	Power/OK LED: green	17 - 18	HDD filler

Callout	Description	Callout	Description
7	Power button	19	DVD filler

## Oracle Database Appliance X6-2S/X6-2M Back Panel

The following figure shows the components on the back panel of an **Oracle Database Appliance X6-2S/X6-2M**.

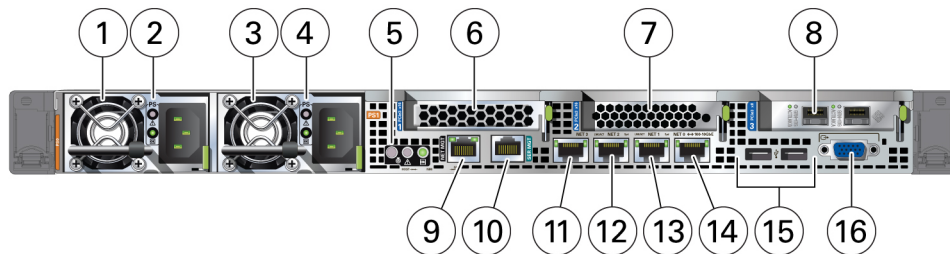

Callout	Description	Callout	Description
1	Power Supply (PS) 0 with fan module	9	NET MGT port. Service processor 10/100/1000Base-T network interface port with RJ-45 connector used to connect to Oracle Integrated Lights Out Manager (ILOM) <b>Caution</b> - The management ports are intended for use by service engineers only.
2	Power Supply (PS) 0 status indicators: Service Required LED: amber, AC OK LED: green	10	SER MGT port. Service processor RJ-45 serial port used to connect to Oracle ILOM <b>Caution</b> - The management ports are intended for use by service engineers only.
3	Power Supply (PS) 1 with fan module	11	10 GbE network interface port with RJ-45 connector <b>Note</b> - Ethernet ports NET 2 and NET 3 are nonfunctional in Oracle Database Appliance X6-2S.
4	Power Supply (PS) 1 status indicators: Service Required LED: amber, AC OK LED: green	12	10 GbE network interface port with RJ-45 connector <b>Note</b> - Ethernet ports NET 2 and NET 3 are nonfunctional in Oracle Database Appliance X6-2S.
5	System status indicators: Locate LED: white, Service Required LED: amber, Power/OK LED: green	13	10 GbE network interface port with RJ-45 connector

Callout	Description	Callout	Description
6	PCIe card slot 1: empty	14	10 GbE network interface port with RJ-45 connector
7	PCIe card slot 2: NVMe Switch PCIe Card	15	USB 2.0 connectors (2)
8	PCIe card slot 3. Dual 10 GbE SFP+ PCIe 2.0 Low Profile Adapter. Provides two 10 GbE dual-rate SFP+ ports.	16	DB-15 video connector
	PCIe card slot 4 (internal). Dual-port Internal 12Gb/s SAS3 host bus adapter. Provides support for the server's internal SAS storage.		

## Oracle Database Appliance X6-2L Front Panel

The Oracle Database Appliance X6-2L server occupies 2RU.

The following figure shows the components on the front panel of an **Oracle Database Appliance X6-2L**.

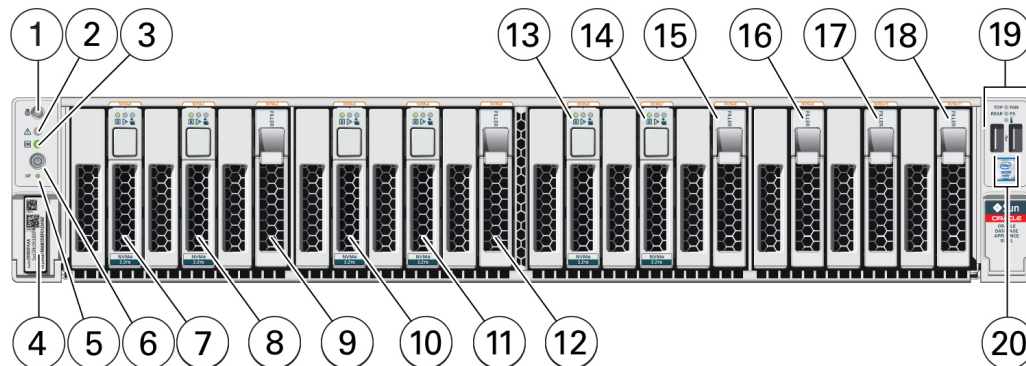

Callout	Description	Callout	Description
1	Locate LED/button: white	6	Power button
2	Service Required LED: amber	7 - 15	NVMe0, NVMe1, NVMe2 (or HDD filler), NVMe3, NVMe4, NVMe5 (or HDD filler), NVMe6, NVMe7, NVMe8 (or HDD filler) <b>Note</b> - Slots NVMe2 (callout 9), NVMe5 (callout 12) and NVMe8 (callout 15) are available for storage expansion on base configuration models. See <a href="#">“Optional Component Installation”</a> on page 74.
3	Power/OK LED: green	16 - 18	Slots NVMe9 - NVMe11

Callout	Description	Callout	Description
4	Product Serial Number (PSN) label and Radio Frequency Identification (RFID) tag	19	Top Fan Fault LED: amber  Power Supply (PS) Fault LED: amber  System Over Temperature Warning LED: amber
5	SP OK LED: green	20	USB 2.0 connectors (2)

## Oracle Database Appliance X6-2L Back Panel

The following figure shows the components on the **Oracle Database Appliance X6-2L back panel**.

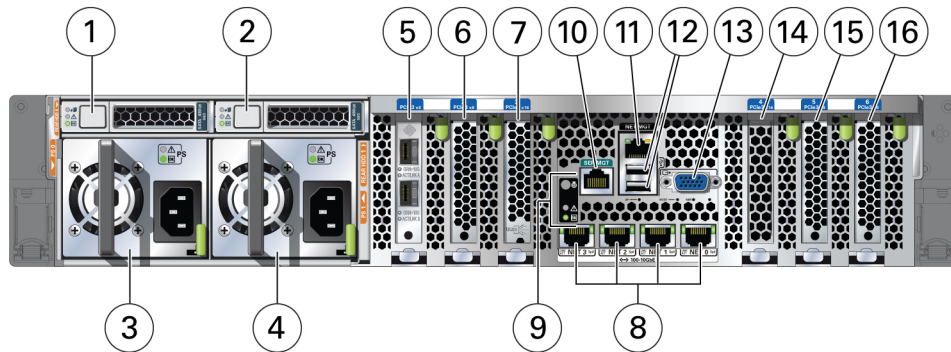

Callout	Description	Callout	Description
1	rear HDD 0 (boot drive)	9	System status indicators: Locate LED: white, Service Required LED: amber, Power/OK LED: green
2	rear HDD 1 (boot drive)	10	SER MGT port. Service processor RJ-45 serial port used to connect to Oracle ILOM <b>Caution</b> - The management ports are intended for use by service engineers only.
3	Power Supply (PS) 0 with fan module  Power Supply (PS) 0 status indicators: Service Required LED: amber, AC OK LED: green	11	NET MGT port. Service processor 10/100/1000Base-T network interface port with RJ-45 connector used to connect to Oracle Integrated Lights Out Manager (ILOM)



Callout	Description	Callout	Description
			<b>Caution</b> - The management ports are intended for use by service engineers only.
4	Power Supply (PS) 1 with fan module  Power Supply (PS) 1 status indicators: Service Required LED: amber, AC OK LED: green	12	USB 2.0 connectors (2)
5	PCIe card slot 1: Sun Dual 10GbE SFP+ PCIe 2.0 Low Profile Adapter	13	DB-15 video connector
6	PCIe card slot 2: Oracle NVMe Switch PCIe card	14	PCIe card slot 4: Filler panel
7	PCIe card slot 3: Oracle Storage 12 Gb SAS3 PCIe RAID Internal HBA	15	PCIe card slot 5: Oracle NVMe Switch PCIe card
8	Four 10 GbE network interface ports with RJ-45 connectors	16	PCIe card slot 6: Oracle NVMe Switch PCIe card

## Oracle Database Appliance X6-2-HA Front and Back Panels

This section describes Oracle Database Appliance X6-2-HA front and back panels.

If you have Oracle Database Appliance X6-2S/X6-2M/X6-2L, see [“Oracle Database Appliance X6-2S/X6-2M/X6-2L Front and Back Panels” on page 32](#). If you have Oracle Database Appliance X7-2S/X7-2M, see [“Oracle Database Appliance X7-2S/X7-2M Front and Back Panels” on page 22](#). If you have Oracle Database Appliance X7-2-HA, see [“Oracle Database Appliance X7-2-HA Front and Back Panels” on page 25](#). If you have Oracle Database Appliance X5-2, see [“Oracle Database Appliance X5-2 Front and Back Panels” on page 44](#). If you have Oracle Database Appliance X3-2/X4-2, see [“Oracle Database Appliance X3-2/X4-2 Front and Back Panels” on page 51](#). If you have Oracle Database Appliance Version 1, see [“Oracle Database Appliance Version 1 Front and Back Panels” on page 58](#).

- [“Oracle Database Appliance X6-2-HA Front Panel” on page 37](#)
- [“Oracle Database Appliance X6-2-HA Back Panel” on page 40](#)

## Oracle Database Appliance X6-2-HA Front Panel

Oracle Database Appliance X6-2-HA includes two server nodes (two Oracle Server X6-2's) and an Oracle DE3-24C storage shelf. The entire unit occupies 6RU. The optional storage expansion shelf requires an additional 4RU, increasing the total to 10RU.

The following figure shows the front of Oracle Database Appliance X6-2-HA with an optional storage expansion shelf.

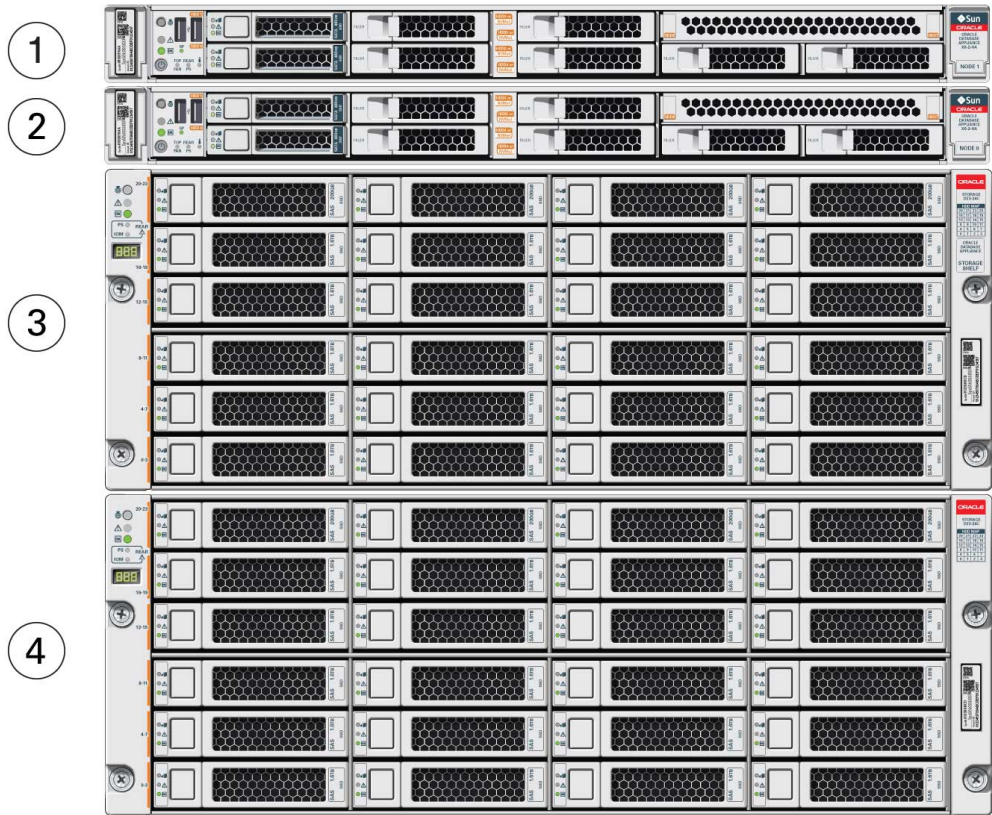

Callout	Description
1	Server node 1
2	Server node 0
3	Storage shelf (DE3-24C)
4	Optional storage expansion shelf (DE3-24C)

## Server Node Front Panel Features

The following figure shows the components on the front panel of an **Oracle Database Appliance X6-2-HA server node**.

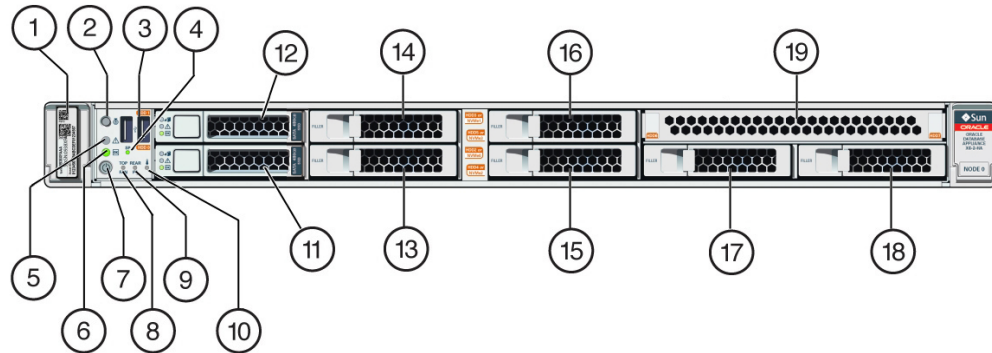

Callout	Description	Callout	Description
1	Product Serial Number (PSN) label and Radio Frequency Identification (RFID) tag	8	Fan Fault LED: amber
2	Locate LED/button: white	9	Power Supply (PS) Fault LED: amber
3	USB 2.0 connectors (2)	10	System Over Temperature Warning LED: amber
4	SP OK LED: green	11	HDD 0 (boot drive)
5	Service Required LED: amber	12	HDD 1 (boot drive)
6	Power/OK LED: green	13 - 18	HDD filler
7	Power button	19	DVD filler

**Note** - When contacting Oracle Support Services, use the Top Level Identifier (TLI) instead of the serial number. You can find the TLI by looking at the top of either server node or on the top of the storage shelf. For details, see [“Technical Support” on page 68](#).

## Storage Shelf Front Panel Features

The following figure shows the **Oracle Database Appliance X6-2-HA storage shelf** front panel features.

**Note** - In the base configuration storage shelf, disk slots 10-19 are empty (filler panels only). The system deployment will fail if the placement of the disks in the base configuration is changed.

You have the option of upgrading the base configuration storage shelf to add an additional ten 1.6 TB SAS SSDs in slots 10-19. See [“Optional Component Installation” on page 74](#). Upgrading the base configuration to a fully populated storage shelf will allow you to add a storage expansion shelf later, if needed.

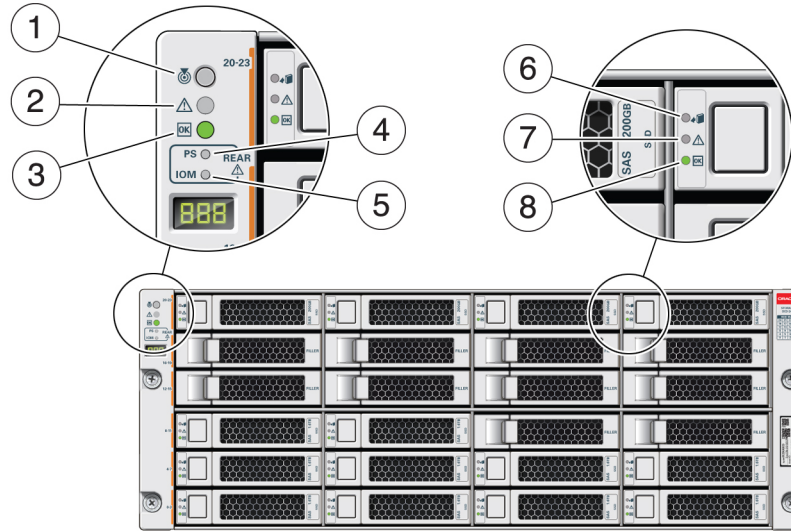

Callout	Description
1	Storage shelf Locate indicator
2	Storage shelf fault indicator
3	Storage shelf OK/power indicator
4	Storage shelf power supply fault indicator
5	Storage shelf IO module fault indicator
6	Drive Ready-to-Remove indicator
7	Drive fault indicator
8	Drive power/activity indicator

## Oracle Database Appliance X6-2-HA Back Panel

This section describes the back panel features for Oracle Database Appliance X6-2-HA. The following figure shows the back of Oracle Database Appliance X6-2-HA.

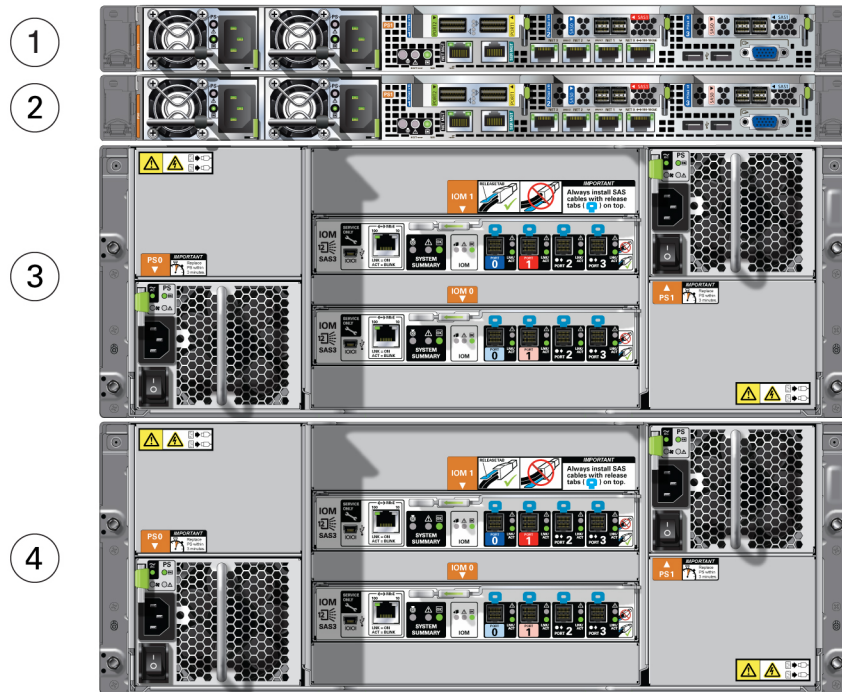

Callout	Description
1	Server node 1
2	Server node 0
3	Storage shelf (DE3-24C)
4	Optional storage expansion shelf (DE3-24C)

## Server Node Back Panel Features

The following figure shows the components on the **Oracle Database Appliance X6-2-HA server node** back panel.

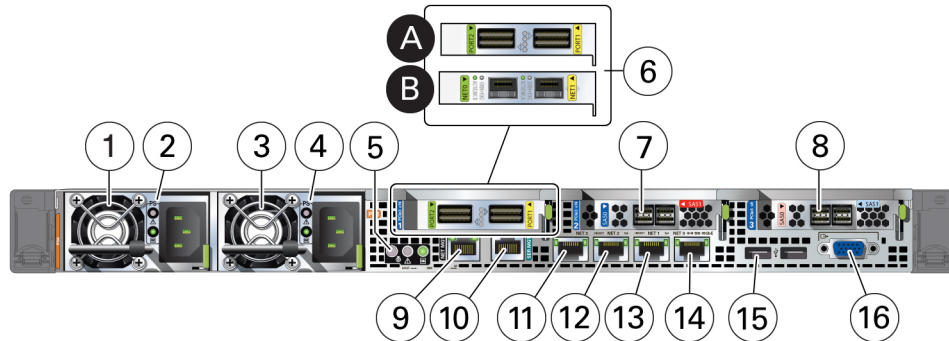

Callout	Description	Callout	Description
1	Power Supply (PS) 0 with fan module	9	NET MGT port. Service processor 10/100/1000Base-T network interface port with RJ-45 connector used to connect to Oracle Integrated Lights Out Manager (ILOM) <b>Caution</b> - The management ports are intended for use by service engineers only.
2	Power Supply (PS) 0 status indicators: Service Required LED: amber, AC OK LED: green	10	SER MGT port. Service processor RJ-45 serial port used to connect to Oracle ILOM <b>Caution</b> - The management ports are intended for use by service engineers only.
3	Power Supply (PS) 1 with fan module	11	10 GbE network interface port with RJ-45 connector
4	Power Supply (PS) 1 status indicators: Service Required LED: amber, AC OK LED: green	12	10 GbE network interface port with RJ-45 connector
5	System status indicators: Locate LED: white, Service Required LED: amber, Power/OK LED: green	13	10 GbE network interface port with RJ-45 connector
6	Two interface options are available from the factory for the appliance: <ul style="list-style-type: none"> <li>■ 6a: PCIe card slot 1. Provides two InfiniBand network interface ports with QSFP+ connections for a private cluster interconnect between server nodes.</li> <li>--or--</li> <li>■ 6b: PCIe card slot 1. Provides two 10GbE network interface ports with SFP+ connections for the data center or public network.</li> </ul> Create the private cluster interconnect between the server nodes using two of each server node's four built-in 10 GbE network interface ports with RJ-45	14	10 GbE network interface port with RJ-45 connector

Callout	Description	Callout	Description
	connections. Refer to the <i>Deployment and User's Guide</i> for more information.		
7	PCIe card slot 2. Provides two SAS3 connectors used to connect the servers to the storage shelf and the storage expansion shelf.	15	USB 2.0 connectors (2)
8	PCIe card slot 3. Provides two SAS3 connectors used to connect the servers to the storage shelf and the storage expansion shelf.	16	DB-15 video connector

## Storage Shelf Back Panel Features

The following figure shows the **Oracle Database Appliance X6-2-HA storage shelf** back panel features.



**Caution** - The network ports on the storage shelf are intended for use by service engineers only.

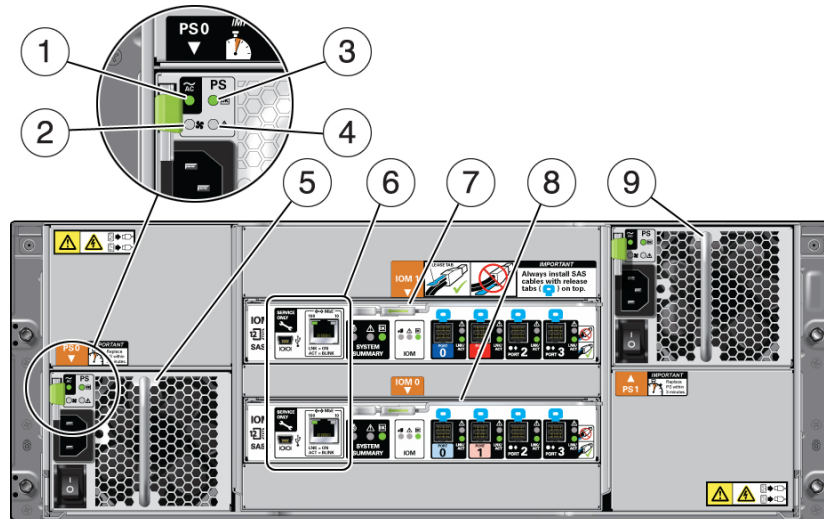

Callout	Description
1	AC power indicator
2	Fan fail indicator



Callout	Description
3	Power supply status indicator
4	DC power fail indicator
5	Power Supply with Fan Module 0
6	Service ports (reserved for Oracle Service only)
7	SAS I/O module 1
8	SAS I/O module 0
9	Power Supply with Fan Module 1

## Oracle Database Appliance X5-2 Front and Back Panels

This section describes Oracle Database Appliance X5-2 front and back panels.

If you have Oracle Database Appliance X7-2S/X7-2M, see [“Oracle Database Appliance X7-2S/X7-2M Front and Back Panels” on page 22](#). If you have Oracle Database Appliance X7-2-HA, see [“Oracle Database Appliance X7-2-HA Front and Back Panels” on page 25](#). If you have Oracle Database Appliance X6-2S/X6-2M/X6-2L, see [“Oracle Database Appliance X6-2S/X6-2M/X6-2L Front and Back Panels” on page 32](#). If you have Oracle Database Appliance X6-2-HA, see [“Oracle Database Appliance X6-2-HA Front and Back Panels” on page 37](#). If you have Oracle Database Appliance X3-2/X4-2, see [“Oracle Database Appliance X3-2/X4-2 Front and Back Panels” on page 51](#). If you have Oracle Database Appliance Version 1, see [“Oracle Database Appliance Version 1 Front and Back Panels” on page 58](#).

- [“Oracle Database Appliance X5-2 Front Panel” on page 44](#)
- [“Oracle Database Appliance X5-2 Back Panel” on page 47](#)

## Oracle Database Appliance X5-2 Front Panel

Oracle Database Appliance X5-2 includes two server nodes (two Oracle Server X5-2's) and an Oracle DE2-24C storage shelf. The entire unit occupies 6RU. The optional storage expansion shelf requires an additional 4RU, increasing the total to 10RU.

The following figure shows the front of Oracle Database Appliance X5-2 with an optional storage expansion shelf.



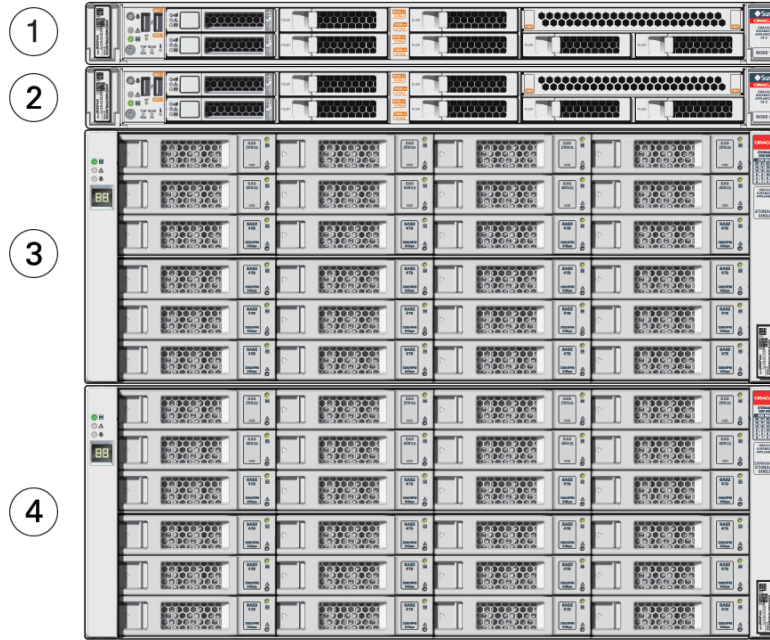

Callout	Description
1	Server node 1
2	Server node 0
3	Storage shelf (DE2-24C)
4	Optional storage expansion shelf (DE2-24C)

## Server Node Front Panel Features

The following figure shows the components on the front panel of an **Oracle Database Appliance X5-2 server node**.

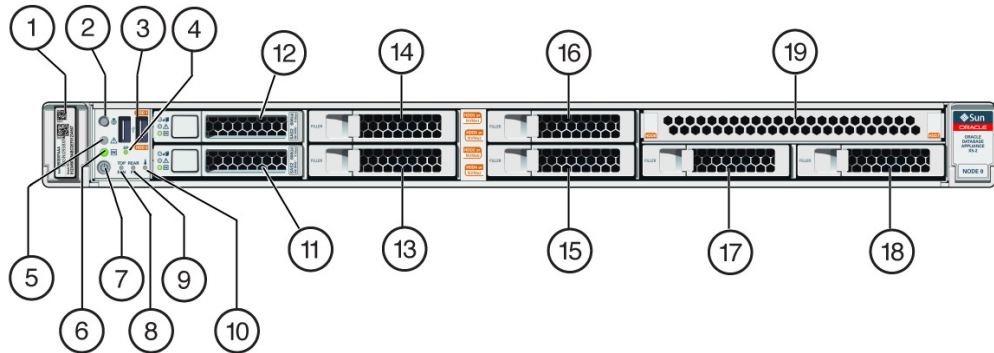

Callout	Description	Callout	Description
1	Product Serial Number (PSN) label and Radio Frequency Identification (RFID) tag	8	Fan Fault LED: amber
2	Locate LED/button: white	9	Power Supply (PS) Fault LED: amber
3	USB 2.0 connectors (2)	10	System Over Temperature Warning LED: amber
4	SP OK LED: green	11	HDD 0 (boot drive)
5	Service Required LED: amber	12	HDD 1 (boot drive)
6	Power/OK LED: green	13 - 18	HDD filler
7	Power button	19	DVD filler

**Note** - When contacting Oracle Support Services, use the Top Level Identifier (TLI) instead of the serial number. You can find the TLI by looking at the top of either server node or on the top of the storage shelf. For details, see [“Technical Support” on page 68](#).

## Storage Shelf Front Panel Features

The following figure shows the **Oracle Database Appliance X5-2 storage shelf** front panel features.

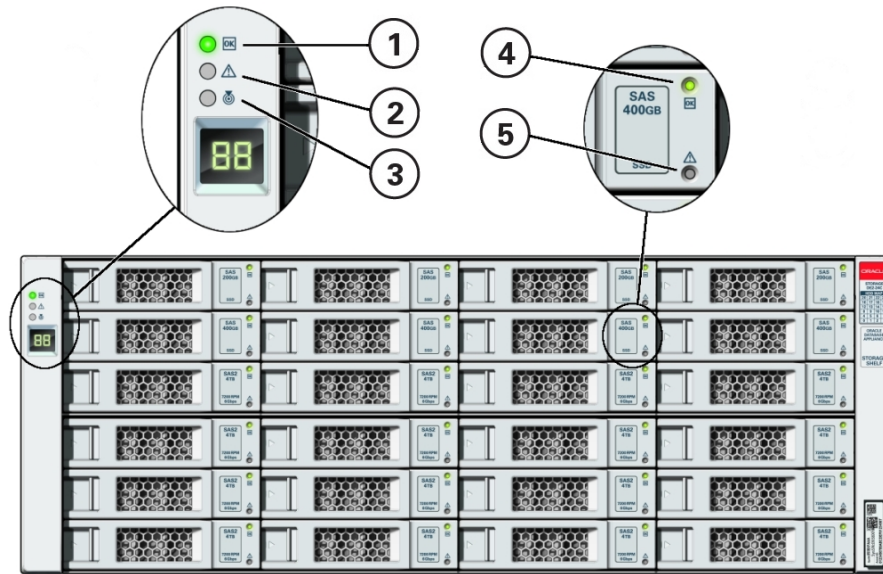

Callout	Description
1	Storage shelf OK/power indicator
2	Storage shelf fault indicator
3	Storage shelf Locate indicator
4	Drive power/activity indicator
5	Drive fault indicator

## Oracle Database Appliance X5-2 Back Panel

This section describes the back panel features for Oracle Database Appliance X5-2. The following figure shows the back of Oracle Database Appliance X5-2.

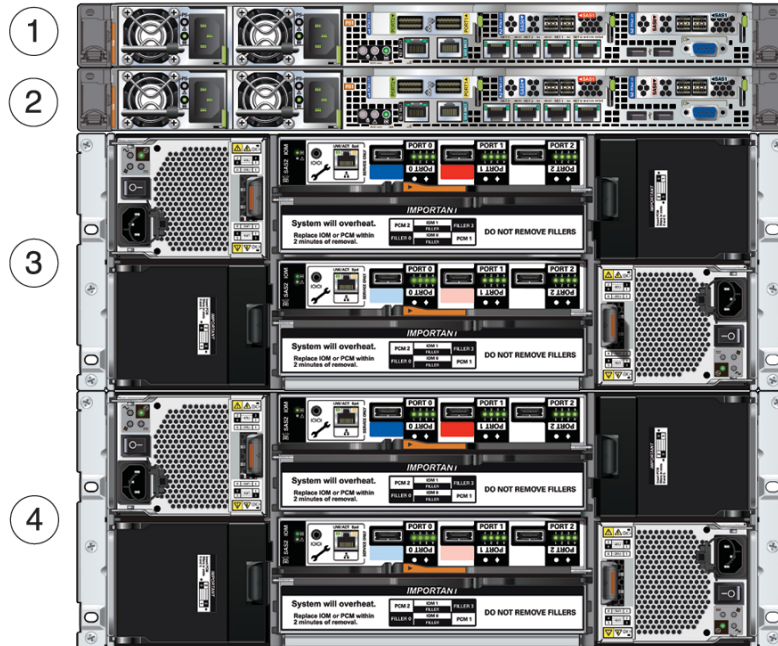

Callout	Description
1	Server node 1
2	Server node 0
3	Storage shelf (DE2-24C)
4	Optional storage expansion shelf (DE2-24C)

## Server Node Back Panel Features

The following figure shows the components on the **Oracle Database Appliance X5-2 server node** back panel.

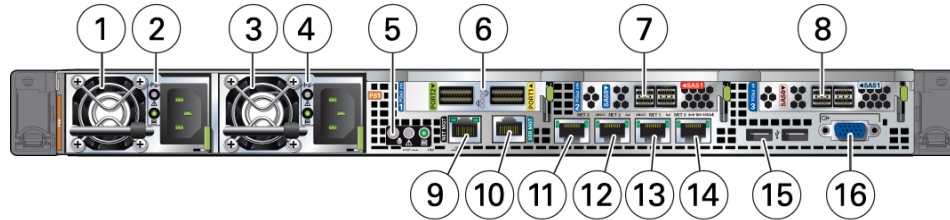

Callout	Description	Callout	Description
1	Power Supply (PS) 0 with fan module	9	NET MGT port. Service processor 10/100/1000Base-T network interface port with RJ-45 connector used to connect to Oracle Integrated Lights Out Manager (ILOM) <b>Caution</b> - The management ports are intended for use by service engineers only.
2	Power Supply (PS) 0 status indicators: Service Required LED: amber, AC OK LED: green	10	SER MGT port. Service processor RJ-45 serial port used to connect to Oracle ILOM <b>Caution</b> - The management ports are intended for use by service engineers only.
3	Power Supply (PS) 1 with fan module	11	10 GbE network interface port with RJ-45 connector
4	Power Supply (PS) 1 status indicators: Service Required LED: amber, AC OK LED: green	12	10 GbE network interface port with RJ-45 connector
5	System status indicators: Locate LED: white, Service Required LED: amber, Power/OK LED: green	13	10 GbE network interface port with RJ-45 connector
6	PCIe card slot 1. Provides two InfiniBand network interface ports with QSFP+ connections for a private cluster interconnect between server nodes.  Alternatively, you have the option of creating the node-to-node interconnection using two of each server node's four 10 GbE network interface ports with RJ-45 connections. Refer to the <i>Oracle Database Appliance Getting Started Guide</i> for more information.	14	10 GbE network interface port with RJ-45 connector
7	PCIe card slot 2. Provides two SAS3 connectors used to connect the servers to the storage shelf and the storage expansion shelf.	15	USB 2.0 connectors (2)
8	PCIe card slot 3. Provides two SAS3 connectors used to connect the servers to the storage shelf and the storage expansion shelf.	16	DB-15 video connector

## Storage Shelf Back Panel Features

The following figure shows the **Oracle Database Appliance X5-2 storage shelf** back panel features.



**Caution** - The network ports on the storage shelf are intended for use by service engineers only.

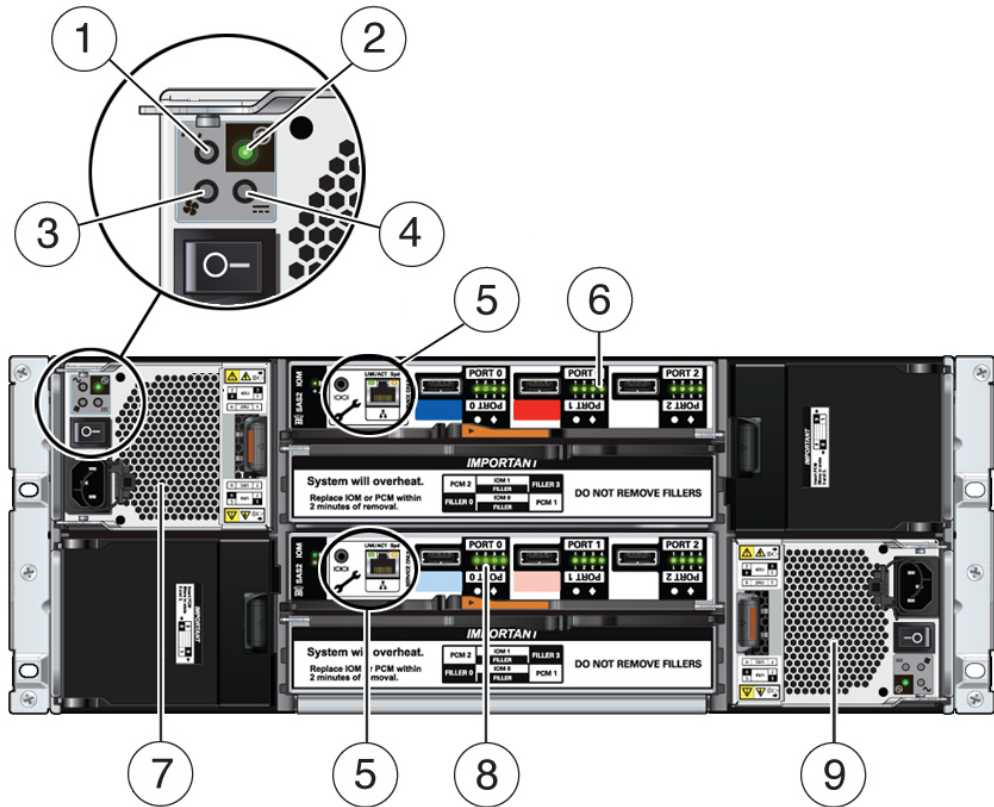

Callout	Description
1	AC power fail indicator
2	Power supply status indicator
3	Fan fail indicator
4	DC power fail indicator

Callout	Description
5	Service ports (reserved for Oracle Service only)
6	SAS I/O module 1
7	Power Supply with Fan Module 2
8	SAS I/O module 0
	Power Supply with Fan Module 1
9	Power Supply with Fan Module 1

## Oracle Database Appliance X3-2/X4-2 Front and Back Panels

This section describes Oracle Database Appliance X3-2/X4-2 front and back panels.

If you have Oracle Database Appliance X7-2S/X7-2M, see [“Oracle Database Appliance X7-2S/X7-2M Front and Back Panels” on page 22](#). If you have Oracle Database Appliance X7-2-HA, see [“Oracle Database Appliance X7-2-HA Front and Back Panels” on page 25](#). If you have Oracle Database Appliance X6-2/X6-2M/X6-2L, see [“Oracle Database Appliance X6-2S/X6-2M/X6-2L Front and Back Panels” on page 32](#). If you have Oracle Database Appliance X6-2-HA, see [“Oracle Database Appliance X6-2-HA Front and Back Panels” on page 37](#). If you have Oracle Database Appliance X5-2, see [“Oracle Database Appliance X5-2 Front and Back Panels” on page 44](#). If you have Oracle Database Appliance Version 1, see [“Oracle Database Appliance Version 1 Front and Back Panels” on page 58](#).

- [“Oracle Database Appliance X3-2/X4-2 Front Panel” on page 51](#)
- [“Oracle Database Appliance X3-2/X4-2 Back Panel” on page 54](#)

## Oracle Database Appliance X3-2/X4-2 Front Panel

Oracle Database Appliance X3-2/X4-2 includes two server nodes (either two Sun Server X3-2's, or two Sun Server X4-2's) and an Oracle DE2-24P storage shelf. The entire unit occupies 4RU. The optional DE2-24P storage expansion shelf requires an additional 2RU, increasing the total to 6RU.

The following figure shows the front of Oracle Database Appliance X3-2 with an optional storage expansion shelf. Except for product labeling, Oracle Database Appliance X4-2 is identical in appearance.



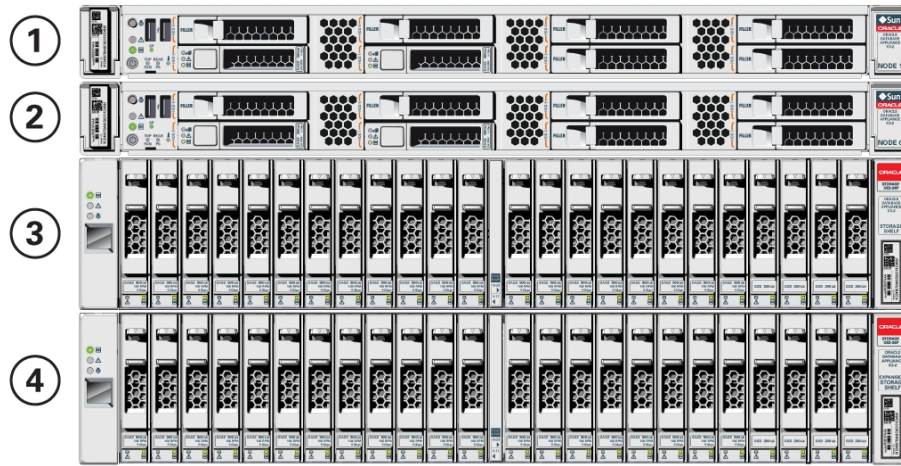

Callout	Description
1	Server node 1
2	Server node 0
3	Storage shelf (DE2-24P)
4	Optional storage expansion shelf (DE2-24P)

## Server Node Front Panel Features

The following figure shows the components on the front panel of an **Oracle Database Appliance X3-2/X4-2 server node**.



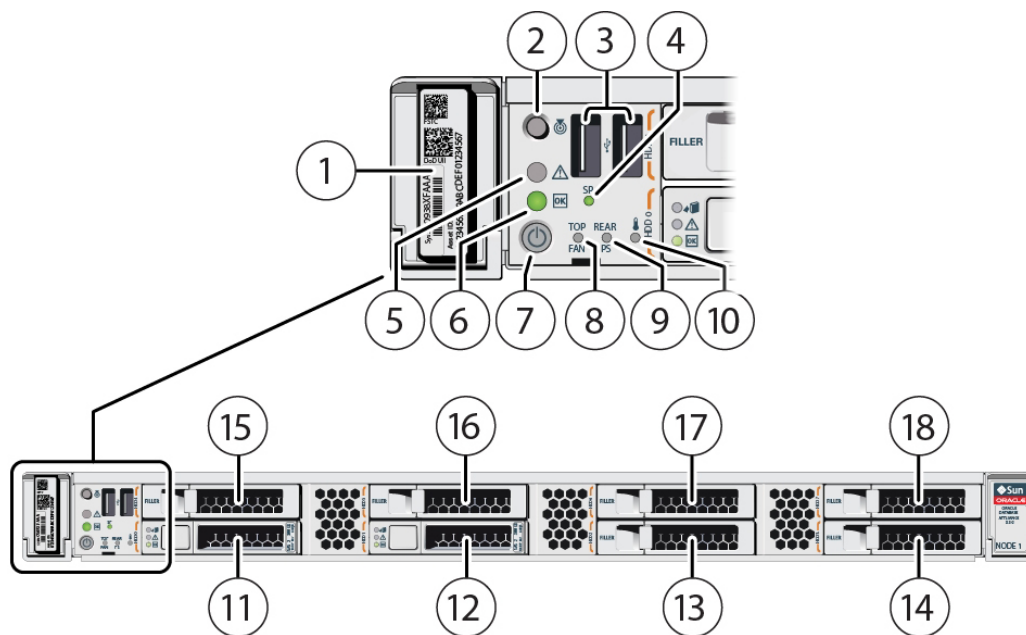

Callout	Description	Callout	Description
1	Product Serial Number (PSN) label and Radio Frequency Identification (RFID) tag	10	System Over Temperature Warning LED: amber
2	Locate LED/button: white	11	HDD 0 (boot drive)
3	USB 2.0 connectors (2)	12	HDD 1 (boot drive)
4	SP OK LED: green	13	HDD filler
5	Service Required LED: amber	14	HDD filler
6	Power/OK LED: green	15	HDD filler
7	Power button	16	HDD filler
8	Fan Fault LED: amber	17	HDD filler
9	Power Supply (PS) Fault LED: amber	18	HDD filler

**Note** - When contacting Oracle Support Services, use the Top Level Identifier (TLI) instead of the serial number. You can find the TLI by looking at the top of either server node or on the top of the storage shelf. For details, see [“Technical Support” on page 68](#).

## Storage Shelf Front Panel Features

The following figure shows the **Oracle Database Appliance X3-2/X4-2 storage shelf** front panel features.

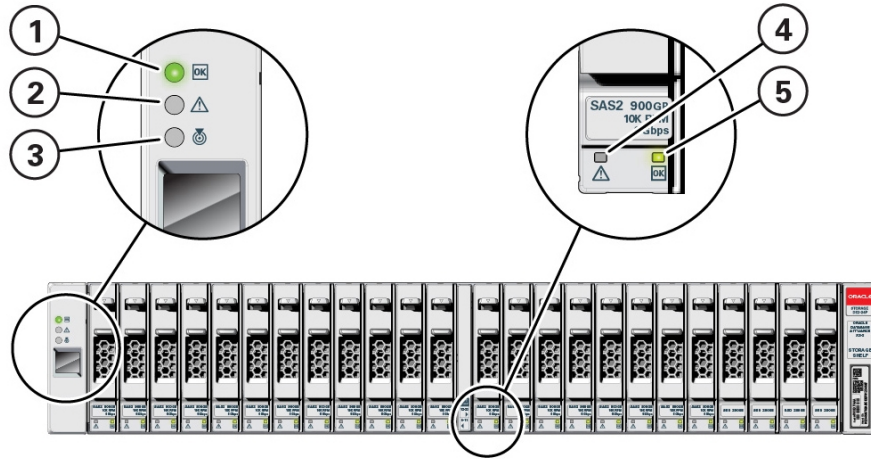

Callout	Description
1	Storage shelf OK/power indicator
2	Storage shelf fault indicator
3	Storage shelf Locate indicator
4	Drive fault indicator
5	Drive power/activity indicator

## Oracle Database Appliance X3-2/X4-2 Back Panel

This section describes the back panel features for Oracle Database Appliance X3-2/X4-2. The following figure shows the back of Oracle Database Appliance X4-2. The Oracle Database Appliance X3-2 and Oracle Database Appliance X4-2 are identical except for the network card in PCIe slot 1 (see [“Server Node Back Panel Features”](#) on page 55).

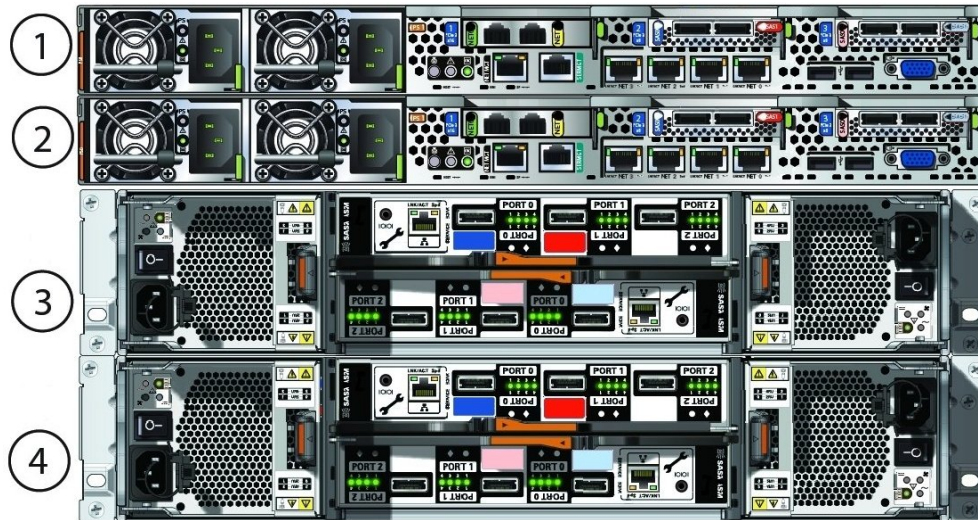

Callout	Description
1	Server node 1
2	Server node 0
3	Storage shelf (DE2-24P)
4	Optional storage expansion shelf (DE2-24P)

## Server Node Back Panel Features

The following figure shows the components on the **Oracle Database Appliance X3-2/X4-2 server node** back panel.

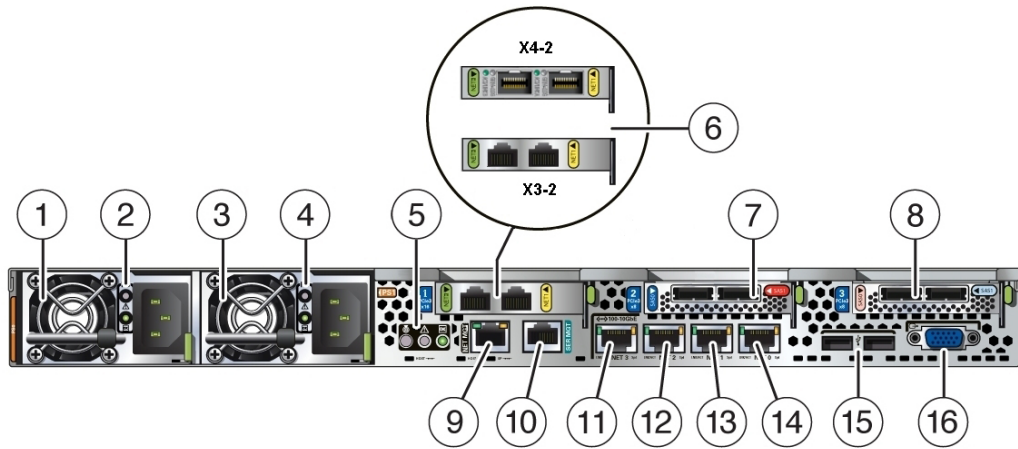

Callout	Description	Callout	Description
1	Power Supply (PS) 0 with fan module	9	NET MGT port. Service processor 10/100BASE-T network interface port with RJ-45 connector used to connect to Oracle Integrated Lights Out Manager (ILOM) <b>Caution</b> - The management ports are intended for use by service engineers only.
2	Power Supply (PS) 0 status indicators: Service Required LED: amber, AC OK LED: green	10	SER MGT port. Service processor RJ-45 serial port used to connect to Oracle ILOM <b>Caution</b> - The management ports are intended for use by service engineers only.
3	Power Supply (PS) 1 with fan module	11	10 GbE network interface port with RJ-45 connector
4	Power Supply (PS) 1 status indicators: Service Required LED: amber, AC OK LED: green	12	10 GbE network interface port with RJ-45 connector
5	System status indicators: Locate LED: white, Service Required LED: amber, Power/OK LED: green	13	10 GbE network interface port with RJ-45 connector
6	<b>Oracle Database Appliance X4-2:</b> PCIe card slot 1. Provides two 10 GbE dual-rate SFP+ ports for a private cluster interconnect between server nodes.  Alternatively, you have the option of creating the node-to-node interconnection using two of each server node's four 10 GbE network interface ports with RJ-45 connections. Refer to the <i>Oracle Database Appliance Getting Started Guide</i> for more information.  <b>Oracle Database Appliance X3-2:</b> PCIe card slot 1. Provides two 10 GbE network interface ports with RJ-45 connectors for a	14	10 GbE network interface port with RJ-45 connector

Callout	Description	Callout	Description
	private cluster interconnect between server nodes.		
7	PCIe card slot 2. Provides two SAS2 connectors used to connect the servers to the storage shelf and the storage expansion shelf.	15	USB 2.0 connectors (2)
8	PCIe card slot 3. Provides two SAS2 connectors used to connect the servers to the storage shelf and the storage expansion shelf.	16	DB-15 video connector

## Storage Shelf Back Panel Features

The following figure shows the **Oracle Database Appliance X3-2/X4-2 storage shelf** back panel features.



**Caution** - The network ports on the storage shelf are intended for use by service engineers only.

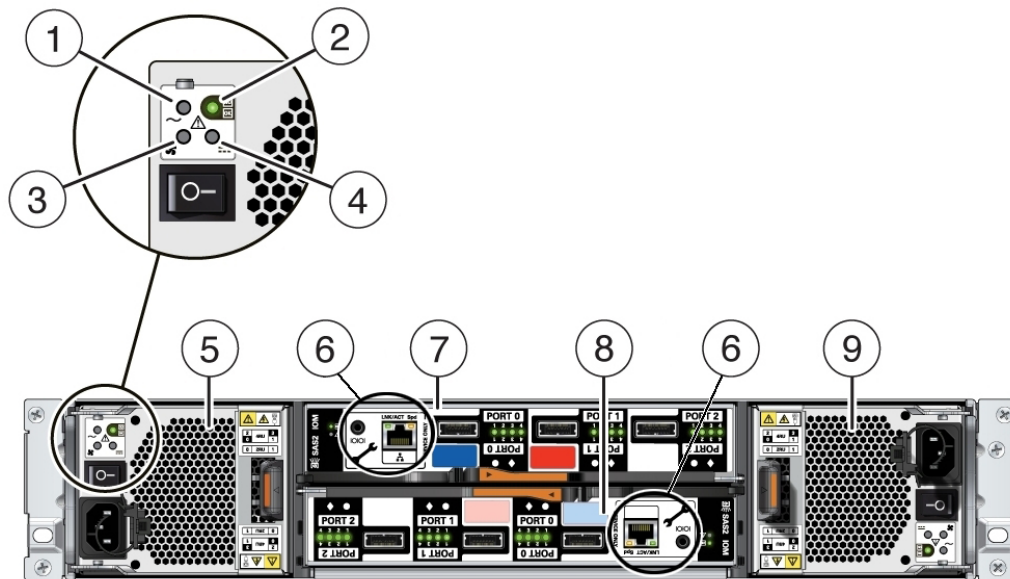

Callout	Description
1	AC power fail indicator
2	Power supply status indicator

Callout	Description
3	Fan fail indicator
4	DC power fail indicator
5	Power Supply with Fan Module 0
6	Service ports (reserved for Oracle Service only)
7	SAS I/O module 1
8	SAS I/O module 0
9	Power Supply with Fan Module 1

## Oracle Database Appliance Version 1 Front and Back Panels

This section describes Oracle Database Appliance Version 1 front and back panels.

If you have Oracle Database Appliance X7-2S/X7-2M, see [“Oracle Database Appliance X7-2S/X7-2M Front and Back Panels” on page 22](#). If you have Oracle Database Appliance X7-2-HA, see [“Oracle Database Appliance X7-2-HA Front and Back Panels” on page 25](#). If you have Oracle Database Appliance X6-2S/X6-2M/X6-2L, see [“Oracle Database Appliance X6-2S/X6-2M/X6-2L Front and Back Panels” on page 32](#). If you have Oracle Database Appliance X6-2-HA, see [“Oracle Database Appliance X6-2-HA Front and Back Panels” on page 37](#). If you have Oracle Database Appliance X5-2, see [“Oracle Database Appliance X5-2 Front and Back Panels” on page 44](#). If you have Oracle Database Appliance X3-2/X4-2, see [“Oracle Database Appliance X3-2/X4-2 Front and Back Panels” on page 51](#).

- [“Oracle Database Appliance Version 1 Front Panel” on page 58](#)
- [“Oracle Database Appliance Version 1 Back Panel” on page 60](#)

## Oracle Database Appliance Version 1 Front Panel

Oracle Database Appliance Version 1 includes two server nodes, SN0 and SN1. SN0 is on the bottom and SN1 is on the top. Server nodes are also called system controllers.

The following figure shows **Oracle Database Appliance Version 1** front panel and describes its components.

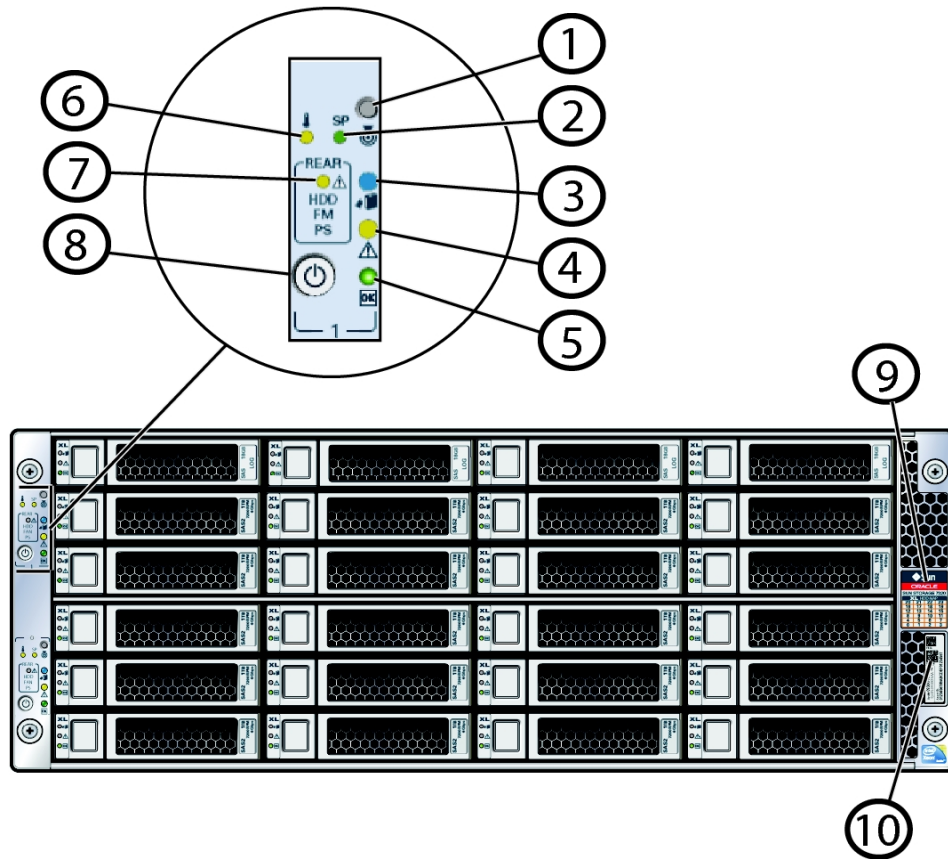

**Note** - The system has **two** each of items 1 through 8; one for each server node. It has only **one** RFID, product serial number tag, and, drive map.

Callout	Description
1	Locate button/LED (white)
2	SP (service processor) OK LED (green = OK, amber = fault)
3	Server Node Ready to Remove LED (blue)
4	Service Required LED (amber)
5	Power/OK LED (green)
6	System Over Temperature LED (amber)
7	Rear HDD (hard disk drive)/PS (power supply)/Fan Fault LED (amber)
8	Power button (recessed)
9	Drive map
10	RFID (radio frequency identification) and product serial number tag



## Oracle Database Appliance Version 1 Back Panel

The following figure shows **Oracle Database Appliance Version 1** back panel and identifies the components on SN0. The components on SN1 are identical.

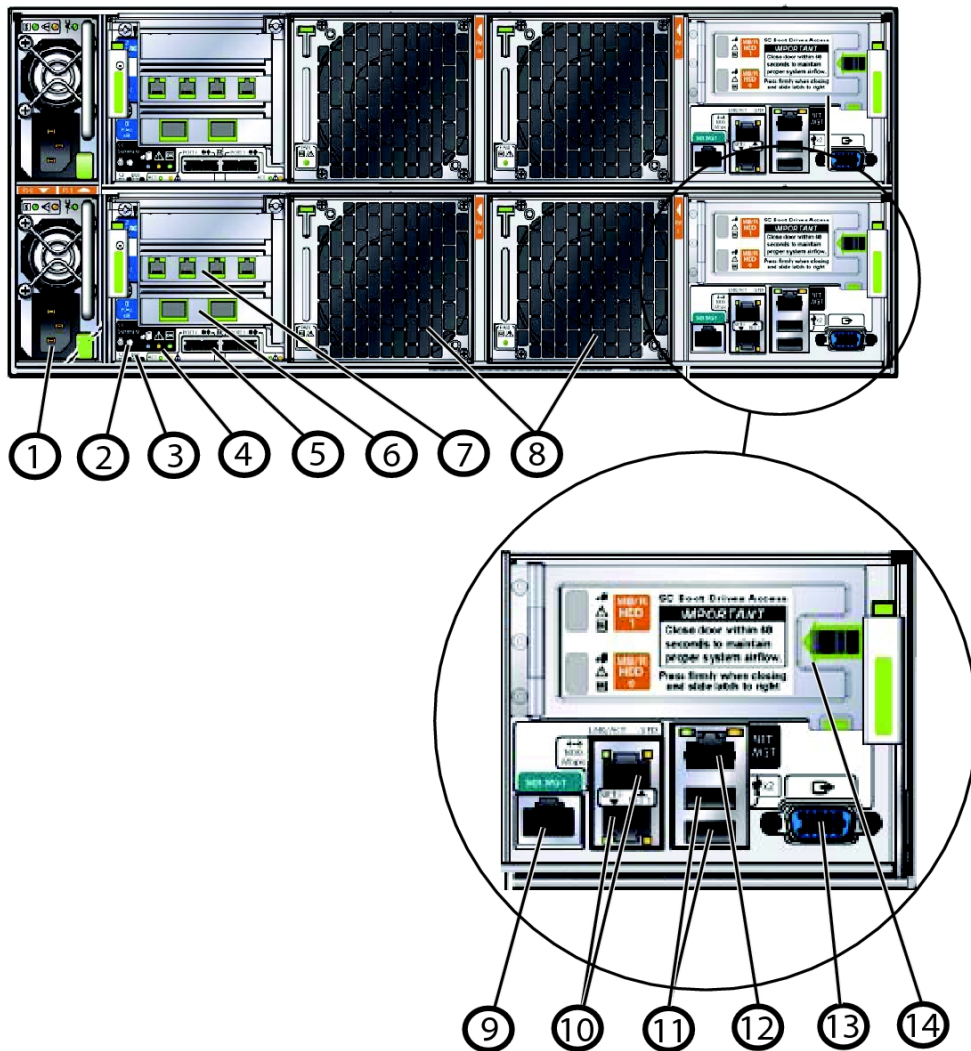

Callout	Description	Callout	Description
1	Power Supply Unit (PSU)	8	Fans



Callout	Description	Callout	Description
2	Locate button/LED (white)	9	SER MGT port. Service processor RJ-45 serial port used to connect to Oracle ILOM <b>Caution</b> - The management ports are intended for use by service engineers only.
3	Host nonmaskable interrupt (NMI) and SP reset recessed switches	10	Dual onboard 1 GbE network interface ports with RJ-45 connectors
4	Status LEDs:  <ul style="list-style-type: none"> <li>■ Server Node Ready to Remove LED (blue)</li> <li>■ Service required LED (amber)</li> <li>■ Power/OK LED (green)</li> </ul>	11	USB ports
5	External MiniSAS ports (2 per server node) – Reserved. Do not use or connect cables to these ports	12	NET MGT port. Service processor 10/100BASE-T network interface port with RJ-45 connector used to connect to Oracle Integrated Lights Out Manager (ILOM) <b>Caution</b> - The management ports are intended for use by service engineers only.
6	PCI Express (PCIe) slot 0 – Dual 10 GbE network interface ports	13	Video connector to console
7	PCIe slot 1 – Quad 1 GbE network interface ports with RJ-45 connectors	14	Rear hard disk drives (RHDDs) (boot drives; 2 per server node) <b>Note</b> - The RHDDs are behind hinged access panels.

## Oracle Database Appliance Specifications

This section describes the physical, electrical and Environmental specifications for the various versions of Oracle Database Appliance.

- [“Physical Specifications” on page 61](#)
- [“Electrical Specifications” on page 63](#)
- [“Environmental Specifications” on page 65](#)

## Physical Specifications

This section describes the physical specifications for the various versions of Oracle Database Appliance.

## Physical Specifications for Oracle Database Appliance X7-2 Series

Item	Oracle Database Appliance X7-2S	Oracle Database Appliance X7-2M	Oracle Database Appliance X7-2-HA
Height	42.6 mm (1.7 in)	42.6 mm (1.7 in)	42.6 mm (1.7 in) per server node  175 mm (6.9 in) per storage shelf
Width	436.5 mm (17.2 in.)	436.5 mm (17.2 in.)	436.5 mm (17.2 in.) per server node  Storage shelf: 446.0 mm (17.6 in)
Depth	737.0 mm (29.0 in)	737.0 mm (29.0 in)	737.0 mm (29.0 in) per server node  Storage shelf: 558.0 mm (22.0 in)
Weight	16.1 kg (34.5 lbs)	16.1 kg (34.5 lbs)	16.1 kg (34.5 lbs) per server node  38.0 kg (84.0 lbs) per storage shelf

## Physical Specifications for Oracle Database Appliance X6-2 Series

Item	Oracle Database Appliance X6-2S	Oracle Database Appliance X6-2M	Oracle Database Appliance X6-2L	Oracle Database Appliance X6-2-HA
Height	42.6 mm (1.7 in)	42.6 mm (1.7 in)	87.6 mm (3.5 in)	42.6 mm (1.7 in) per server node  175 mm (6.9 in) per storage shelf
Width	436.5 mm (17.2 in)	436.5 mm (17.2 in)	445.0 mm (17.5 in)	436.5 mm (17.2 in) per server node  Storage shelf: 446.0 mm (17.6 in)
Depth	737.0 mm (29.0 in)	737.0 mm (29.0 in)	737.0 mm (29.0 in)	737.0 mm (29.0 in) per server node  Storage shelf: 558.0 mm (22.0 in)
Weight	16.1 kg (35.4 lbs)	16.1 kg (35.4 lbs)	29.0 kg (64.0 lbs)	16.1 kg (35.4 lbs) per server node

Item	Oracle Database Appliance X6-2S	Oracle Database Appliance X6-2M	Oracle Database Appliance X6-2L	Oracle Database Appliance X6-2-HA
				38.0 kg (84.0 lbs) per storage shelf

## Physical Specifications for Oracle Database Appliance Version 1 and Models X3-2, X4-2 and X5-2

Item	Oracle Database Appliance Version 1	Oracle Database Appliance X3-2/X4-2	Oracle Database Appliance X5-2
Height	175.1 mm (6.9 in)	42.6 mm (1.7 in) per server node 87.9 mm (3.5 in) per storage shelf	42.6 mm (1.7 in) per server node 175 mm (6.9 in) per storage shelf
Width	437.0 mm (17.2 in) (without mounting ears) 482.6 mm (19 in) (with mounting ears)	Server node: 436.5 mm (17.2 in) Storage shelf: 483.0 mm (19.0 in)	Server node: 436.5 mm (17.2 in) Storage shelf: 483.0 mm (19.0 in)
Depth	762.0 mm (30.0 in) 782.0 mm (30.8 in) (including fan module handles and latches)	Server node: 737.0 mm (29.0 in) Storage shelf: 630.0 mm (24.8 in)	Server node: 737.0 mm (29.0 in) Storage shelf: 630.0 mm (24.8 in)
Weight	72.6 kg (160.0 lbs)	16.3 kg (36.0 lbs) per server node 24.0 kg (52.9 lbs) per storage shelf	16.3 kg (36.0 lbs) per server node 37.2 kg (82.0 lbs) per storage shelf

## Electrical Specifications

This section describes the electrical specifications for the various versions of Oracle Database Appliance.

### Electrical Specifications for Oracle Database Appliance X7-2 Series

Item	Oracle Database Appliance X7-2S	Oracle Database Appliance X7-2M	Oracle Database Appliance X7-2-HA
Server node power supply output rated maximum	1200W at 100-127 VAC 1200W at 200-240 VAC	1200W at 100-127 VAC 1200W at 200-240 VAC	1200W at 100-127 VAC 1200W at 200-240 VAC

Item	Oracle Database Appliance X7-2S	Oracle Database Appliance X7-2M	Oracle Database Appliance X7-2-HA
Server node AC power	7.2A at 100-127 VAC 3.4A at 200-240 VAC	7.2A at 100-127 VAC 3.4A at 200-240 VAC	7.2A at 100-127 VAC 3.4A at 200-240 VAC
Storage shelf power supply output rated maximum	Not included	Not included	580W at 100-127 VAC 580W at 200-240 VAC
Storage shelf AC Power	Not included	Not included	8A at 100-127 VAC 3A at 220-240 VAC
Power usage	For more information on power consumption, see Oracle Server X7-2 <a href="#">Power Calculator</a> .	For more information on power consumption, see Oracle Server X7-2 <a href="#">Power Calculator</a> .	Server node <ul style="list-style-type: none"> <li>■ Maximum: 479W</li> <li>■ Active idle: 172W</li> </ul> Storage shelf <ul style="list-style-type: none"> <li>■ Maximum: 453W</li> <li>■ Typical: 322W</li> </ul>

## Electrical Specifications for Oracle Database Appliance X6-2 Series

Item	Oracle Database Appliance X6-2S	Oracle Database Appliance X6-2M	Oracle Database Appliance X6-2L	Oracle Database Appliance X6-2-HA
Server node power supply output rated maximum	600W at 100-127 VAC 600W at 200-240 VAC	600W at 100-127 VAC 600W at 200-240 VAC	1000W at 100-127 VAC 1000W at 200-240 VAC	600W at 100-127 VAC 600W at 200-240 VAC
Server node AC power	7.2A at 100-127 VAC 3.4A at 200-240 VAC	7.2A at 100-127 VAC 3.4A at 200-240 VAC	8.5 -12A at 100-127 VAC 5.7A at 200-240 VAC	7.2A at 100-127 VAC 3.4A at 200-240 VAC
Storage shelf power supply output rated maximum	Not included	Not included	Not included	580W at 100-127 VAC 580W at 200-240 VAC
Storage shelf AC Power	Not included	Not included	Not included	8A at 100-127 VAC 3A at 220-240 VAC
Power usage	For more information on power consumption,	For more information on power consumption,	For more information on power consumption,	Server node <ul style="list-style-type: none"> <li>■ Maximum: 336W</li> </ul>

Item	Oracle Database Appliance X6-2S	Oracle Database Appliance X6-2M	Oracle Database Appliance X6-2L	Oracle Database Appliance X6-2-HA
	see Oracle Server X6-2 <a href="#">Power Calculator</a> .	see Oracle Server X6-2 <a href="#">Power Calculator</a> .	see Oracle Server X6-2L <a href="#">Power Calculator</a> .	<ul style="list-style-type: none"> <li>■ Active idle: 142W</li> </ul> Storage shelf <ul style="list-style-type: none"> <li>■ Maximum: 453W</li> <li>■ Typical: 322W</li> </ul>

## Electrical Specifications for Oracle Database Appliance Version 1 and Models X3-2, X4-2 and X5-2

Item	Oracle Database Appliance Version 1	Oracle Database Appliance X3-2/X4-2	Oracle Database Appliance X5-2
Server node power supply output rated maximum	1270W at 100-120 VAC 1370W at 200-240 VAC	600W at 100-127 VAC 600W at 200-240 VAC	600W at 100-127 VAC 600W at 200-240 VAC
Server node AC power	12A at 110-127 VAC 7A at 200-240 VAC 13A at 100 VAC (Japan only)	7.2A at 100-127 VAC 3.4A at 200-240 VAC	7.2A at 100-127 VAC 3.4A at 200-240 VAC
Storage shelf power supply output rated maximum	Not supported	580W at 100-127 VAC 580W at 200-240 VAC	580W at 100-127 VAC 580W at 200-240 VAC
Storage shelf AC Power	Not supported	8A at 100-127 VAC 3A at 220-240 VAC	8A at 100-127 VAC 3A at 220-240 VAC
Power usage	Not available	Server node <ul style="list-style-type: none"> <li>■ X4-2 maximum: 439W X4-2 typical: 164W</li> <li>■ X3-2 maximum: 551W X3-2 typical: 178W</li> </ul> Storage shelf <ul style="list-style-type: none"> <li>■ Maximum: 699W</li> <li>■ Typical: 325W</li> </ul>	Server node <ul style="list-style-type: none"> <li>■ Maximum: 727W</li> <li>■ Typical: 508W</li> </ul> Storage shelf <ul style="list-style-type: none"> <li>■ Maximum: 699W</li> <li>■ Typical: 469W</li> </ul>

## Environmental Specifications

This section describes the environmental specifications for a single, non-racked Oracle Database Appliance.

## Environmental Specifications for Oracle Database Appliance X7-2 Series

Item	Oracle Database Appliance X7-2S	Oracle Database Appliance X7-2M	Oracle Database Appliance X7-2-HA
Operating temperature	5° C to 35° C (41° F to 95° F).	5° C to 35° C (41° F to 95° F)	5° C to 35° C (41° F to 95° F)
Nonoperating temperature	-40° C to 70° C (-40° F to 158° F).	-40° C to 70° C (-40° F to 158° F)	-40° C to 70° C (-40° F to 158° F)
Operating humidity	10% to 90% relative humidity, noncondensing	10% to 90% relative humidity, noncondensing	10% to 90% relative humidity, noncondensing
Nonoperating humidity	Up to 93% relative humidity, noncondensing.	Up to 93% relative humidity, non-condensing	Up to 93% relative humidity, non-condensing
Operating altitude	Up to 3,000 m* (9,840 ft); maximum ambient temperature is derated by 1° C per 300 m above 900 m	Up to 3,000 m* (9,840 ft); maximum ambient temperature is derated by 1° C per 300 m above 900 m	Up to 3,000 m* (9,840 ft); maximum ambient temperature is derated by 1° C per 300 m above 900 m
	* Except in China markets where regulations might limit installations to a maximum altitude of 2,000 m (6,560 ft).	* Except in China where regulations might limit installations to a maximum altitude of 2,000 m (6,560 ft).	* Except in China where regulations might limit installations to a maximum altitude of 2,000 m (6,560 ft).
Nonoperating altitude	Up to 12,000 m (39,370 ft)	Up to 12,000 m (39,370 ft)	Up to 12,000 m (39,370 ft)
Cooling	For more information on power consumption, see Oracle Server X7-2 <a href="#">Power Calculator</a> .	For more information on power consumption, see Oracle Server X7-2 <a href="#">Power Calculator</a> .	Server node <ul style="list-style-type: none"> <li>■ At maximum usage: 1146 BTU/h</li> <li>■ At typical usage: 485 BTU/h</li> </ul> Storage shelf <ul style="list-style-type: none"> <li>■ At maximum usage: 1553 BTU/h</li> <li>■ At typical usage: 874 BTU/h</li> </ul>
Acoustic noise	7.0 Bels A-weighted operating, 7.0 Bels A-weighted idling	7.0 Bels A-weighted operating, 7.0 Bels A-weighted idling	7.0 Bels A-weighted operating, 7.0 Bels A-weighted idling

## Environmental Specifications for Oracle Database Appliance X6-2 Series

Item	Oracle Database Appliance X6-2S	Oracle Database Appliance X6-2M	Oracle Database Appliance X6-2L	Oracle Database Appliance X6-2-HA
Operating temperature	5° C to 35° C (41° F to 95° F).	5° C to 35° C (41° F to 95° F)	5° C to 35° C (41° F to 95° F)	5° C to 35° C (41° F to 95° F)

Item	Oracle Database Appliance X6-2S	Oracle Database Appliance X6-2M	Oracle Database Appliance X6-2L	Oracle Database Appliance X6-2-HA
Nonoperating temperature	40° C to 70° C (-40° F to 158° F).	-40° C to 70° C (-40° F to 158° F)	-40° C to 70° C (-40° F to 158° F)	-40° C to 70° C (-40° F to 158° F)
Operating humidity	10% to 90% relative humidity, noncondensing	10% to 90% relative humidity, noncondensing	10% to 90% relative humidity, noncondensing	10% to 90% relative humidity, noncondensing
Nonoperating humidity	Up to 93% relative humidity, noncondensing.	Up to 93% relative humidity, noncondensing	Up to 93% relative humidity, noncondensing	Up to 93% relative humidity, noncondensing
Operating altitude	Up to 3,000 m* (9,840 ft); maximum ambient temperature is derated by 1° C per 300 m above 900 m  * Except in China markets where regulations might limit installations to a maximum altitude of 2,000 m (6,560 ft).	Up to 3,000 m* (9,840 ft); maximum ambient temperature is derated by 1° C per 300 m above 900 m  * Except in China where regulations might limit installations to a maximum altitude of 2,000 m (6,560 ft).	Up to 3,000 m* (9,840 ft); maximum ambient temperature is derated by 1° C per 300 m above 900 m  * Except in China where regulations might limit installations to a maximum altitude of 2,000 m (6,560 ft).	Up to 3,000 m* (9,840 ft); maximum ambient temperature is derated by 1° C per 300 m above 900 m  * Except in China where regulations might limit installations to a maximum altitude of 2,000 m (6,560 ft).
Nonoperating altitude	Up to 12,000 m (39,370 ft)	Up to 12,000 m (39,370 ft)	Up to 12,000 m (39,370 ft)	Up to 12,000 m (39,370 ft)
Cooling	For more information on power consumption, see <a href="#">Oracle Server X6-2 Power Calculator</a> .	For more information on power consumption, see <a href="#">Oracle Server X6-2 Power Calculator</a> .	For more information on power consumption, see <a href="#">Oracle Server X6-2L Power Calculator</a> .	Server node <ul style="list-style-type: none"> <li>■ At maximum usage: 1146 BTU/h</li> <li>■ At typical usage: 485 BTU/h</li> </ul> Storage shelf <ul style="list-style-type: none"> <li>■ At maximum usage: 1553 BTU/h</li> <li>■ At typical usage: 874 BTU/h</li> </ul>
Acoustic noise	7.0 Bels A-weighted operating, 7.0 Bels A-weighted idling	7.0 Bels A-weighted operating, 7.0 Bels A-weighted idling	8.1 Bels A-weighted operating, 5.8 Bels A-weighted idling	7.0 Bels A-weighted operating, 7.0 Bels A-weighted idling

## Environmental Specifications for Oracle Database Appliance Version 1 and Models X3-2, X4-2 and X5-2

Item	Oracle Database Appliance Version 1	Oracle Database Appliance X3-2/X4-2	Oracle Database Appliance X5-2
Operating temperature	5° C to 35° C (41° F to 95° F).	5° C to 35° C (41° F to 95° F)	5° C to 35° C (41° F to 95° F)
Nonoperating temperature	-40° C to 70° C (-40° F to 158° F).	-40° C to 70° C (-40° F to 158° F)	-40° C to 70° C (-40° F to 158° F)

Item	Oracle Database Appliance Version 1	Oracle Database Appliance X3-2/X4-2	Oracle Database Appliance X5-2
Operating humidity	10% to 90% relative humidity, noncondensing	10% to 90% relative humidity, noncondensing	10% to 90% relative humidity, noncondensing
Nonoperating humidity	Up to 93% relative humidity, noncondensing.	Up to 93% relative humidity, non-condensing	Up to 93% relative humidity, non-condensing
Operating altitude	Up to 3000 m* (9,840 ft). Maximum ambient temperature is derated by 1 °C per 300 m (984 ft) above 900 m (2,953 ft)	Up to 3,048 m* (10,000 ft); maximum ambient temperature is derated by 1° C per 300 m above 900 m	Up to 3,048 m* (10,000 ft); maximum ambient temperature is derated by 1° C per 300 m above 900 m
	* Except in China markets where regulations might limit installations to a maximum altitude of 2,000 m (6,562 ft).	* Except in China where regulations might limit installations to a maximum altitude of 2,000 m (6,562 ft).	* Except in China where regulations might limit installations to a maximum altitude of 2,000 m (6,562 ft).
Nonoperating altitude	Up to 12,000 m (39,370 ft)	Up to 12,000 m (39,370 ft)	Up to 12,000 m (39,370 ft)
Cooling	Not available	Server node <ul style="list-style-type: none"> <li>■ X4-2 at maximum usage: 1498 BTU/h</li> <li style="padding-left: 20px;">X4-2 at typical usage: 560 BTU/h</li> <li>■ X3-2 at maximum usage: 1744 BTU/h</li> <li style="padding-left: 20px;">X3-2 at typical usage: 607 BTU/h</li> </ul> Storage shelf <ul style="list-style-type: none"> <li>■ At maximum usage: 2385 BTU/h</li> <li>■ At typical usage: 1108 BTU/h</li> </ul>	Server node <ul style="list-style-type: none"> <li>■ At maximum usage: 2482 BTU/h</li> <li>■ At typical usage: 1734 BTU/h</li> </ul> Storage shelf <ul style="list-style-type: none"> <li>■ At maximum usage: 2385 BTU/h</li> <li>■ At typical usage: 1600 BTU/h</li> </ul>
Acoustic noise	7.8 B operating, 7.1 B idling (LwAd: 1 B=10 dB)	7.9 B operating, 5.58 B idling (LwAd: 1 B=10 dB)	7.0 Bels A-weighted operating, 7.0 Bels A-weighted idling

## Technical Support

For technical support, go to:

<https://support.oracle.com>

When requesting technical support for Oracle Database Appliance, report the following to Oracle Support Services:



---

**Oracle Database Appliance Version 1, X6-2S/X6-2M/X6-2L and X7-2S/X7-2M**

For the Oracle Database Appliance Version 1, X6-2S/X6-2M/X6-2L and X7-2S/X7-2M, report the serial number located on the front panel of the system, the top of the system, or on the Customer Information Sheet that is shipped with the system.

**Note** - You only need to extend the server node a couple of inches on its slide rails to see the serial label on the top of the system. You do not need to release any cables, or slide it to the extended maintenance position.

**Oracle Database Appliance X3-2/X4-2/X5-2 and X6-2-HA/X7-2-HA**

For Oracle Database Appliance X3-2/X4-2/X5-2 and X6-2-HA/X7-2-HA, report the Top Level Identifier (TLI). To see the TLI, look on the Customer Information Sheet or look at the top of a server node or storage shelf on the left-hand side towards the front.

The TLI part number and TLI serial number are the same for all factory-bundled components of an appliance. For example:



If the appliance is in a rack where you cannot see the TLI, do one of the following:

- Look on another component (server node or storage shelf) of the appliance. All factory-bundled components of Oracle Database Appliance have the same TLI numbers.
- Slide a server node partway out on its rails, just far enough to see the TLI. See the *Oracle Database Appliance Service Manual* for details.

**Note** - You only need to extend the server node a couple of inches on its slide rails to see the TLI. You do not need to release any cables, or slide it to the extended maintenance position.

---



## Site Preparation

---

This chapter describes the tasks you must complete *before* installing Oracle Database Appliance into a rack and cabling it.

### Preparing Your Site

Use the following procedure to prepare your site for Oracle Database Appliance installation:

#### ▼ Prepare Your Site

1. Ensure that your site meets the environmental requirements in [“Environmental Specifications” on page 65](#).
2. Ensure that your site meets the electrical specifications in [“Electrical Specifications” on page 63](#).
3. Ensure that your site has adequate clearance for the shipping containers.
4. **Allow the equipment to acclimatize to the computer center environment.**

If significant temperature differences exist ( $> 10^{\circ}\text{C} / 18^{\circ}\text{F}$ ) between the new system and the designated computer center, the equipment should be left in its boxes for a sufficient period of time to allow the temperature of the equipment to come to within a few degrees of the computer center.



---

**Caution - Equipment damage.** The system should never be powered on unless it is within the supported operating range (temperature and humidity).

---

5. **Open the shipping containers.**

You should do this at the location where the system will be installed, but outside of the computer center itself.



**Caution - Equipment damage.** Use a separate area in which to remove the packaging material to reduce particle contamination before entering the computer center.

**6. Check the contents of the shipping container.**



**Caution - System failure.** All items in a shipment are designed to be used together as a single system. Do not mix components from different shipments; this could cause the system to fail.

It should contain:

Oracle Database Appliance Version 1, X6-2S/X6-2M/X6-2L and X7-2S/X7-2M	Oracle Database Appliance X3-2/X4-2/X5-2 and X6-2-HA/X7-2-HA
<ul style="list-style-type: none"> <li>■ Preconfigured system</li> <li>■ Accessory kit, including:                             <ul style="list-style-type: none"> <li>■ <i>Accessing Product Documentation</i> or Setup booklet</li> <li>■ Safety and legal documentation</li> <li>■ Rackmount guide and alignment template</li> <li>■ Rackmount kit</li> </ul> </li> <li>■ Power cords (shipped separately)</li> <li>■ Shipping kit (optional)</li> </ul>	<ul style="list-style-type: none"> <li>■ <b>The server nodes include:</b> <ul style="list-style-type: none"> <li>■ Preconfigured server nodes (0 and 1)</li> <li>■ Accessory kit, including:                                     <ul style="list-style-type: none"> <li>■ Setup poster</li> <li>■ Safety and legal documentation</li> <li>■ Rackmount guide and alignment template</li> <li>■ Rackmount kit</li> <li>■ Power Cords</li> <li>■ SAS cables, Ethernet cables, cluster cables, and labels are shipped with the storage shelf.</li> </ul> </li> </ul> </li> <li>■ <b>The storage shelf includes:</b> <ul style="list-style-type: none"> <li>■ Preconfigured storage shelf</li> <li>■ Rackmount kit</li> <li>■ Power cords</li> <li>■ Cables</li> <li>■ Setup poster</li> </ul> </li> <li>■ If you ordered a storage expansion shelf, it is shipped separately and includes the same list of components as the storage shelf.</li> </ul>

## Installing the System Into a Rack

---

This chapter includes the following sections:

- “Task Overview” on page 73
- “Optional Component Installation” on page 74
- “Safety Precautions When Rackmounting” on page 76
- “ESD Precautions” on page 77
- “Rack Compatibility Requirements” on page 77
- “Inserting Oracle Database Appliance Into a Rack” on page 80

### Task Overview

Follow the appropriate procedures to rack mount your system.

---

**Note** - These procedures describe how to insert the system into a rack. For cabling instructions, refer to the appropriate *Deployment and User’s Guide* for the Oracle Database Appliance X7 and X6 series or the *Getting Started Guide* for the Oracle Database Appliance X3-2/X4-2/X5-2 or Version 1.

---

Oracle Database Appliance Version 1	Oracle Database Appliance X3-2/X4-2	Oracle Database Appliance X5-2, X6-2-HA and X7-2-HA	Oracle Database Appliance X6-2S/X6-2M/X6-2L and X7-2S/X7-2M
<ul style="list-style-type: none"> <li>■ “Optional Component Installation” on page 74</li> <li>■ “Safety Precautions When Rackmounting” on page 76</li> <li>■ “ESD Precautions” on page 77</li> <li>■ “Rack Compatibility Requirements” on page 77</li> <li>■ “Rackmount Kit Contents” on page 112</li> </ul>	<ul style="list-style-type: none"> <li>■ “Optional Component Installation” on page 74</li> <li>■ “Safety Precautions When Rackmounting” on page 76</li> <li>■ “ESD Precautions” on page 77</li> <li>■ “Rack Compatibility Requirements” on page 77</li> <li>■ “Contents of the Shipping Pallet” on page 84</li> <li>■ “Installation Sequence” on page 84</li> </ul>	<ul style="list-style-type: none"> <li>■ “Optional Component Installation” on page 74</li> <li>■ “Safety Precautions When Rackmounting” on page 76</li> <li>■ “ESD Precautions” on page 77</li> <li>■ “Rack Compatibility Requirements” on page 77</li> <li>■ “Contents of the Shipping Pallet” on page 84</li> <li>■ “Installation Sequence” on page 84</li> </ul>	<ul style="list-style-type: none"> <li>■ “Optional Component Installation” on page 74</li> <li>■ “Safety Precautions When Rackmounting” on page 76</li> <li>■ “ESD Precautions” on page 77</li> <li>■ “Rack Compatibility Requirements” on page 77</li> <li>■ “Contents of the Shipping Container” on page 81</li> <li>■ “Tools and Equipment Needed” on page 82</li> </ul>

Oracle Database Appliance Version 1	Oracle Database Appliance X3-2/X4-2	Oracle Database Appliance X5-2, X6-2-HA and X7-2-HA	Oracle Database Appliance X6-2S/X6-2M/X6-2L and X7-2S/X7-2M
<ul style="list-style-type: none"> <li>■ “Staff, Tools, and Equipment Required to Rackmount the System” on page 114</li> <li>■ “Removing Components to Reduce System Weight” on page 114</li> <li>■ “Install Rackmount Hardware Into a Rack” on page 115</li> <li>■ “Install the System Into a Rack” on page 122</li> <li>■ “Installing Shipping Brackets” on page 126</li> </ul>	<ul style="list-style-type: none"> <li>■ “Verify Component Compatibility” on page 85</li> <li>■ “Tools and Equipment Needed” on page 85</li> <li>■ “Stabilize the Rack for Installation” on page 86</li> <li>■ “Applying Labels” on page 86</li> <li>■ “Installing the Storage Shelves Into a Rack” on page 89</li> <li>■ “Add a Storage Expansion Shelf Into an Existing System” on page 110</li> <li>■ “Installing the Server Nodes Into a Rack” on page 110</li> </ul>	<ul style="list-style-type: none"> <li>■ “Verify Component Compatibility” on page 85</li> <li>■ “Tools and Equipment Needed” on page 85</li> <li>■ “Stabilize the Rack for Installation” on page 86</li> <li>■ “Applying Labels” on page 86</li> <li>■ “Installing the Storage Shelves Into a Rack” on page 89</li> <li>■ “Add a Storage Expansion Shelf Into an Existing System” on page 110</li> <li>■ “Installing the Server Nodes Into a Rack” on page 110</li> </ul>	<ul style="list-style-type: none"> <li>■ “Stabilize the Rack for Installation” on page 82</li> <li>■ “Installing the Server Into a Rack” on page 82</li> </ul>

## Optional Component Installation

Standard system components are installed at the factory. Optional components that you purchased independent of the standard configuration are shipped separately, and in most cases should be installed before you install the server in a rack.

The following optional components can be ordered separately:

- **DIMM memory kits:**
  - For Oracle Database Appliance X7-2S, you have the option of ordering memory expansion to 384 GB. Memory kits come in sets of 6 x 32 GB DIMMs.
  - For Oracle Database Appliance X7-2M, you have the option of ordering memory expansion to 768 GB. Memory kits come in sets of 6 x 32 GB DIMMs, which means you need two kits (one for each processor).
  - For Oracle Database Appliance X7-2-HA, you have the option of ordering memory expansion to 768 GB. Memory kits come in sets of 6 x 32 GB DIMMs, which means you need four kits (two for each server node) for 768 GB. Both server nodes must have the same amount of memory. Thus, the total memory for the appliance becomes 1536 GB.
  - For Oracle Database Appliance X6-2S, you have the option of ordering memory expansion to 384 GB. Memory kits come in sets of 8 x 32 GB DIMMs.
  - For Oracle Database Appliance X6-2M/X6-2L, you have the option of ordering memory expansion to 512 GB or 768 GB. Memory kits come in sets of 8 x 32 GB DIMMs.
  - For Oracle Database Appliance X5-2 and Oracle Database Appliance X6-2-HA, you have the option of ordering memory expansion to 512 GB or 768 GB. Memory kits

come in sets of 8 x 32 GB DIMMs, which means you need two kits (one for each server node) for 512 GB, and four kits (two for each server node) for 768 GB. Both server nodes must have the same amount of memory. Thus, the total memory for the appliance is either 1024 GB or 1536 GB, depending on the expanded configuration.

Refer to the *Service Manual* for instructions on installing memory.

■ **Storage drives:**

- For Oracle Database Appliance X7-2M with the default configuration of two NVMe drives, you have the option of ordering three or six additional 2.5-inch 6.4 TB NVMe SSDs for front drive slots 2-7. Drives are available in three-packs.
- For Oracle Database Appliance X7-2-HA, you have the following options:
  - If your base configuration includes a partially populated storage shelf (filler panels in slots 5-19), you can upgrade it as follows:
    - For a high capacity shelf, you can add fifteen optional 10 TB HDDs (available in a fifteen-pack)

---

**Note** - Adding 10 TB HDDs to the base storage shelf (with five 3.2 TB SSDs and four 800 GB SSDs) requires that you move the 3.2 TB SSDs from shelf storage slots 0-4 to slots 15-19. Doing this will require that you redeploy the appliance and restore the database from a backup.

---

--or--

- For a high performance shelf, you can add up to fifteen 3.2 TB SSDs (available in five-packs)
- An additional storage shelf can be added to the appliance as follows:
  - If your base storage shelf configuration is twenty 3.2 TB SSDs and four 800 GB SSDs, you can purchase an additional storage shelf with the identical configuration (same drives in same slots).

--or--

- If your base storage shelf configuration is five 3.2 TB SSDs, fifteen 10 TB HDDs and four 800 GB SSDs, you can purchase an additional storage shelf with the identical configuration (same drives in same slots).

--or--

- If your base storage shelf configuration is five 3.2 TB SSDs and four 800 GB SSDs (with slots 5-19 empty), you can add an additional storage shelf only after you have upgraded the storage in your existing shelf to match one of the fully populated base configurations listed above.

---

**Note** - You **cannot** add a storage shelf (which comes fully populated) unless your existing storage shelf is fully populated and the storage shelf you purchase is configured identically (same drives in same slots) to your existing storage shelf.

---

- For Oracle Database Appliance X6-2S/X6-2M with the default configuration of two NVMe drives, you have the option of ordering two additional 2.5-inch 3.2 TB NVMe SSDs for front drive slots NVMe 2-3. Drives must be installed in pairs.
- For Oracle Database Appliance X6-2L with the default configuration of six NVMe drives, you have the option of ordering three additional 2.5-inch 3.2 TB NVMe SSDs for front drive slots NVMe2, NVMe5 and NVMe8. Drives must be installed as a set of three. Drive slots NVMe9, NVMe10 and NVMe11 are not supported for use with this product.
- For Oracle Database Appliance X6-2-HA, you have the following options:
  - If your base configuration is a half-populated storage shelf (filler panels in slots 10-19), you can upgrade it to a fully populated storage shelf by adding ten 1.6 TB SAS SSDs to fill the empty drive slots (10-19). Drives must be installed as a set of ten.
  - An additional storage shelf can be added if the existing storage shelf is full populated.

---

**Note** - You **cannot** add a storage expansion shelf (which comes fully populated) unless your existing storage shelf is fully populated.

---

- For Oracle Database Appliance X3-2/X4-2/X5-2 that have a single fully populated storage shelf, you can add one optional storage expansion shelf.

Refer to the *Service Manual* for instructions on installing storage drives.

■ **Other optional configurations:**

For Oracle Database Appliance X5-2, you have the option of ordering two Sun Dual 10GbE SFP+ PCIe 2.0 Low Profile Adapters to replace the two standard InfiniBand adapters (one in each server node) to support an Ethernet fiber connection to the data center or public network (it cannot be used for the appliance private node-to-node connection).

To replace the standard InfiniBand adapter, refer to the *Service Manual* for instructions on replacing a PCIe card in Slot 1. After the card is replaced, refer to the *Getting Started Guide* for instructions on cabling and software configuration.

## Safety Precautions When Rackmounting

This section describes safety precautions you must follow when installing the server into a rack.





---

**Caution - Personal injury or equipment damage.** Prevent the rack from tipping over. 1) Deploy the anti-tilt bar or legs on the equipment rack before beginning an installation. 2) Always load equipment into a rack from the bottom up so that the rack will not become top-heavy and tip over. 3) Mount equipment in the rack such that it does not create uneven or dangerous mechanical loading. 4) Do not use slide-rail mounted equipment as a shelf or workspace.

---



---

**Caution - Equipment damage caused by elevated temperature.** 1) If you install the equipment in a closed or multi-unit rack assembly, ensure that the operating ambient temperature inside the rack does not exceed the maximum ambient temperature specified for the server. For server environmental requirements, see [“Environmental Specifications” on page 65](#). 2) Install the equipment in the rack such that airflow is not restricted or impeded.

---



---

**Caution - Supply circuit damage and data loss.** The AC circuits used to supply power to the system must be rated for the maximum amount of power that the system requires. See [“Electrical Specifications” on page 63](#) for input power requirements.

---



---

**Caution - Equipment damage.** Maintain reliable earthing. Pay particular attention to supply connections other than direct connections to the branch circuit (for example, use of power strips).

---

## ESD Precautions



---

**Caution - Equipment damage.** To prevent damage from electrostatic discharge, use the following precautions when installing or servicing components.

---

- Place components on an antistatic surface, such as an antistatic discharge mat, an antistatic bag, or a disposable antistatic mat.
- Wear an antistatic grounding strap connected to a metal surface on the chassis when you work on system components.

## Rack Compatibility Requirements

The rack-mounting hardware can be used only in specialized racks that meet the requirements in the following tables.

For Oracle Database Appliance X7-2 series:

Feature	Oracle Database Appliance X7-2S/ X7-2M	Oracle Database Appliance X7-2-HA
Rack structure	Four-post rack (mounting at both front and rear). Two-post racks are not compatible.	Four-post rack (mounting at both front and rear). Two-post racks are not compatible.
Space available	Must have 1RU (rack units) of space available.	6RU without optional storage expansion shelf.  10RU with optional storage expansion shelf.
Rack horizontal opening and unit vertical pitch	Conforms to ANSI/EIA 310-D-1992 or IEC 60927 standards.	Conforms to ANSI/EIA 310-D-1992 or IEC 60927 standards.
Distance between front and rear mounting planes	Minimum 610 mm and maximum 915 mm (24 in to 36 in).	Minimum 610 mm and maximum 915 mm (24 in to 36 in).
Clearance depth in front of front mounting plane	Distance to front cabinet door is at least 25.4 mm (1 in).	Distance to front cabinet door is at least 25.4 mm (1 in).
Clearance depth behind front mounting plane	Distance to rear cabinet door is at least 900 mm (35.43 in) with the cable management arm, or 800 mm (31.5 in) without the cable management arm.	Distance to rear cabinet door is at least 900 mm (35.43 in) with the cable management arm, or 800 mm (31.5 in) without the cable management arm.
Clearance width between front and rear mounting planes	Distance between structural supports and cable troughs is at least 456 mm (18 in).	Distance between structural supports and cable troughs is at least 456 mm (18 in).
Minimum clearance for service access	Front clearance: 123.2 cm (48.5 in)  Rear clearance: 91 cm (36 in)	Front clearance: 123.2 cm (48.5 in)  Rear clearance: 91 cm (36 in)
Server node dimensions	<a href="#">“Physical Specifications for Oracle Database Appliance X7-2 Series” on page 62</a>	<a href="#">“Physical Specifications for Oracle Database Appliance X7-2 Series” on page 62</a>
Storage shelf dimensions	N/A	<a href="#">“Physical Specifications for Oracle Database Appliance X7-2 Series” on page 62</a>

For Oracle Database Appliance X6-2 series:

Feature	Oracle Database Appliance X6-2S/X6-2M	Oracle Database Appliance X6-2L	Oracle Database Appliance X6-2-HA
Rack structure	Four-post rack (mounting at both front and rear). Two-post racks are not compatible.	Four-post rack (mounting at both front and rear). Two-post racks are not compatible.	Four-post rack (mounting at both front and rear). Two-post racks are not compatible.
Space available	Must have 1RU (rack units) of space available.	Must have 2RU of space available.	6RU without optional storage expansion shelf.  10RU with optional storage expansion shelf.
Rack horizontal opening and unit vertical pitch	Conforms to ANSI/EIA 310-D-1992 or IEC 60927 standards.	Conforms to ANSI/EIA 310-D-1992 or IEC 60927 standards.	Conforms to ANSI/EIA 310-D-1992 or IEC 60927 standards.

Feature	Oracle Database Appliance X6-2S/X6-2M	Oracle Database Appliance X6-2L	Oracle Database Appliance X6-2-HA
Distance between front and rear mounting planes	Minimum 610 mm and maximum 915 mm (24 in to 36 in).	Minimum 610 mm and maximum 915 mm (24 in to 36 in).	Minimum 610 mm and maximum 915 mm (24 in to 36 in).
Clearance depth in front of front mounting plane	Distance to front cabinet door is at least 25.4 mm (1 in).	Distance to front cabinet door is at least 25.4 mm (1 in).	Distance to front cabinet door is at least 25.4 mm (1 in).
Clearance depth behind front mounting plane	Distance to rear cabinet door is at least 900 mm (35.43 in) with the cable management arm, or 800 mm (31.5 in) without the cable management arm.	Distance to rear cabinet door is at least 900 mm (35.43 in) with the cable management arm, or 800 mm (31.5 in) without the cable management arm.	Distance to rear cabinet door is at least 900 mm (35.43 in) with the cable management arm, or 800 mm (31.5 in) without the cable management arm.
Clearance width between front and rear mounting planes	Distance between structural supports and cable troughs is at least 456 mm (18 in).	Distance between structural supports and cable troughs is at least 456 mm (18 in).	Distance between structural supports and cable troughs is at least 456 mm (18 in).
Minimum clearance for service access	Front clearance: 123.2 cm (48.5 in) Rear clearance: 91 cm (36 in)	Front clearance: 123.2 cm (48.5 in) Rear clearance: 91 cm (36 in)	Front clearance: 123.2 cm (48.5 in) Rear clearance: 91 cm (36 in)
Server node dimensions	<a href="#">“Physical Specifications for Oracle Database Appliance X6-2 Series” on page 62</a>	<a href="#">“Physical Specifications for Oracle Database Appliance X6-2 Series” on page 62</a>	<a href="#">“Physical Specifications for Oracle Database Appliance X6-2 Series” on page 62</a>
Storage shelf dimensions	N/A	N/A	<a href="#">“Physical Specifications for Oracle Database Appliance X6-2 Series” on page 62</a>

## For Oracle Database Appliance Version 1 and Oracle Database Appliance X3-2/X4-2/X5-2:

Feature	Oracle Database Appliance Version 1	Oracle Database Appliance X3-2/X4-2	Oracle Database Appliance X5-2
Rack structure	Four-post rack (mounting at both front and rear). Two-post racks are not compatible.	Four-post rack (mounting at both front and rear). Two-post racks are not compatible.	Four-post rack (mounting at both front and rear). Two-post racks are not compatible.
Space available	Must have 4RU (rack units) of space available.	4RU without optional storage expansion shelf. 6RU with optional storage expansion shelf.	6RU without optional storage expansion shelf. 10RU with optional storage expansion shelf.
Rack horizontal opening and unit vertical pitch	Conforms to ANSI/EIA 310-D-1992 or IEC 60927 standards.	Conforms to ANSI/EIA 310-D-1992 or IEC 60927 standards.	Conforms to ANSI/EIA 310-D-1992 or IEC 60927 standards.
Distance between front and rear mounting planes	Minimum 660.4 mm and maximum 876.3 mm (26 in to 34.5 in).	Minimum 610 mm and maximum 915 mm (24 in to 36 in).	Minimum 610 mm and maximum 915 mm (24 in to 36 in).

Feature	Oracle Database Appliance Version 1	Oracle Database Appliance X3-2/X4-2	Oracle Database Appliance X5-2
Clearance depth in front of front mounting plane	Distance to front cabinet door is at least 25.4 mm (1 in).	Distance to front cabinet door is at least 25.4 mm (1 in).	Distance to front cabinet door is at least 25.4 mm (1 in).
Clearance depth behind front mounting plane	Distance to rear cabinet door is at least 700 mm (27.5 in).	Distance to rear cabinet door is at least 900 mm (35.43 in) with the cable management arm, or 800 mm (31.5 in) without the cable management arm.	Distance to rear cabinet door is at least 900 mm (35.43 in) with the cable management arm, or 800 mm (31.5 in) without the cable management arm.
Clearance width between front and rear mounting planes	Distance between structural supports and cable troughs is at least 456 mm (18 in).	Distance between structural supports and cable troughs is at least 456 mm (18 in).	Distance between structural supports and cable troughs is at least 456 mm (18 in).
Minimum clearance for service access	Front clearance: 123.2 cm (48.5 in)	Front clearance: 123.2 cm (48.5 in)	Front clearance: 123.2 cm (48.5 in)
	Rear clearance: 91 cm (36 in)	Rear clearance: 91 cm (36 in)	Rear clearance: 91 cm (36 in)
Server node dimensions	<a href="#">“Physical Specifications for Oracle Database Appliance Version 1 and Models X3-2, X4-2 and X5-2” on page 63</a>	<a href="#">“Physical Specifications for Oracle Database Appliance Version 1 and Models X3-2, X4-2 and X5-2” on page 63</a>	<a href="#">“Physical Specifications for Oracle Database Appliance Version 1 and Models X3-2, X4-2 and X5-2” on page 63</a>
Storage shelf dimensions	N/A	<a href="#">“Physical Specifications for Oracle Database Appliance Version 1 and Models X3-2, X4-2 and X5-2” on page 63</a>	<a href="#">“Physical Specifications for Oracle Database Appliance Version 1 and Models X3-2, X4-2 and X5-2” on page 63</a>



**Caution - Personal injury or equipment damage.** Always load equipment into a rack from the bottom up so that it will not become top-heavy and tip over. Deploy your rack’s anti-tilt bar to prevent the rack from tilting during equipment installation. This caution is not applicable if an earthquake kit has been installed on the rack and it is bolted to the floor.

## Inserting Oracle Database Appliance Into a Rack

This section describes how to install an Oracle Database Appliance into a rack as follows:

- [“Inserting Oracle Database Appliance X6-2S/X6-2M/X6-2L and X7-2S/X7-2M Into a Rack” on page 81](#)
- [“Inserting Oracle Database Appliance X3-2/X4-2/X5-2 and X6-2-HA/X7-2-HA Into a Rack” on page 83](#)
- [“Inserting Oracle Database Appliance Version 1 Into a Rack” on page 111](#)

## Inserting Oracle Database Appliance X6-2S/X6-2M/X6-2L and X7-2S/X7-2M Into a Rack

This section describes how to install Oracle Database Appliance X6-2S/X6-2M/X6-2L and X7-2S/X7-2M servers into a rack.

If you are installing an Oracle Database Appliance X3-2/X4-2/X5-2 or X6-2-HA/X7-2-HA, see [“Inserting Oracle Database Appliance X3-2/X4-2/X5-2 and X6-2-HA/X7-2-HA Into a Rack” on page 83](#). If you are installing Oracle Database Appliance Version 1, see [“Inserting Oracle Database Appliance Version 1 Into a Rack” on page 111](#).

This section includes the following subsections:

- [“Contents of the Shipping Container” on page 81](#)
- [“Tools and Equipment Needed” on page 82](#)
- [“Stabilize the Rack for Installation” on page 82](#)
- [“Installing the Server Into a Rack” on page 82](#)



---

**Caution - Personal injury or equipment damage.** Always install equipment in a rack from the bottom up.

---



---

**Caution - System Failure.** Oracle Database Appliance is shipped with matched sets of components that must be installed together. Mixing components from different systems might cause the system to fail.

---

### Contents of the Shipping Container

Inspect the shipping cartons of your Oracle Database Appliance X6-2S/X6-2M/X6-2L or X7-2S/X7-2M system for evidence of physical damage. If a shipping carton appears damaged, request that the carrier's agent be present when the carton is opened. Keep all contents and packing material for the agent's inspection.

The ship kit for the server includes the following items:

- Power cords, packaged separately with country kit
- Rail kit containing rack rails, hardware, template and installation instructions
- Miscellaneous hardware, cables, and connectors
- Setup booklet
- Legal and safety documents

## Tools and Equipment Needed

Obtain the following tools and equipment before beginning the installation of Oracle Database Appliance X6-2S/X6-2M/X6-2L or X7-2S/X7-2M.

- Phillips head No. 2 screwdriver that is a minimum of 4 inches long
- T20 Torx driver if using a threaded rack
- A mechanical lift is highly recommended

## ▼ Stabilize the Rack for Installation



---

**Caution - Personal injury or equipment damage.** To reduce the risk of personal injury, stabilize the rack cabinet, and extend all anti-tilt devices before installing the server.

---

See your rack documentation for detailed instructions for the following steps.

1. **Open and remove the front and rear doors from the rack cabinet.**

---

**Note** - The front and rear doors need to be removed only if they interfere with the installation.

---

2. **To prevent the rack cabinet from tipping during the installation, fully extend the rack cabinet's anti-tilt legs or anti-tilt bar, which are located at the bottom front of the rack cabinet.**
3. **If there are leveling feet beneath the rack cabinet to prevent it from rolling, extend these leveling feet fully downward to the floor.**

## Installing the Server Into a Rack

**Install the Oracle Database Appliance X7-2S/X7-2M server into the rack:**

---

**Note** - The links in the following table take you to instructions *outside* of the Oracle Database Appliance library to the Oracle Server X7-2 documentation library. Use your browser's Back button to return to the Oracle Database Appliance library.

---

---

Oracle Database Appliance X7-2S	Oracle Database Appliance X7-2M
---------------------------------	---------------------------------

<a href="#">Verify Rackmount Hardware</a>	<a href="#">Verify Rackmount Hardware</a>
---	---

---

Oracle Database Appliance X7-2S	Oracle Database Appliance X7-2M
<a href="#">Install Mounting Brackets</a>	<a href="#">Install Mounting Brackets</a>
<a href="#">Mark the Rackmount Location</a>	<a href="#">Mark the Rackmount Location</a>
<a href="#">Connect AC Power Cables and Slide-Rails</a>	<a href="#">Connect AC Power Cables and Slide-Rails</a>
<a href="#">Attach the Tool-less Slide-Rail Assemblies</a>	<a href="#">Attach the Tool-less Slide-Rail Assemblies</a>
<a href="#">Install the Server into the Slide-Rail Assemblies</a>	<a href="#">Install the Server into the Slide-Rail Assemblies</a>
<a href="#">Install the Cable Management Arm and Verify Operation</a>	<a href="#">Install the Cable Management Arm and Verify Operation</a>

### Install the Oracle Database Appliance X6-2S/X6-2M/X6-2L server into the rack:

**Note** - The links in the following table take you to instructions *outside* of the Oracle Database Appliance library to the Oracle Server X6-2 or Oracle Server X6-2L documentation libraries. Use your browser's Back button to return to the Oracle Database Appliance library.

Oracle Database Appliance X6-2S/X6-2M	Oracle Database Appliance X6-2L
<a href="#">Verify Rackmount Hardware</a>	<a href="#">Verify Rackmount Hardware</a>
<a href="#">Install Mounting Brackets</a>	<a href="#">Install Mounting Brackets</a>
<a href="#">Mark the Rackmount Location</a>	<a href="#">Mark the Rackmount Location</a>
<a href="#">Connect AC Power Cables Before Installing Tool-less Slide-Rails in Sun Rack II 1042</a>	<a href="#">Connect AC Power Cables Before Installing Tool-less Slide-Rails in Sun Rack II 1042</a>
<a href="#">Attach the Tool-less Slide-Rail Assemblies</a>	<a href="#">Attach the Tool-less Slide-Rail Assemblies</a>
<a href="#">Install the Server into the Slide-Rail Assemblies</a>	<a href="#">Install the Server into the Slide-Rail Assemblies</a>
<a href="#">Install the Cable Management Arm and Verify Operation</a>	<a href="#">Install the Cable Management Arm and Verify Operation</a>
<a href="#">Optional: Install the Shipping Bracket With Cable Trough</a>	<a href="#">Optional: Install the Shipping Bracket With Cable Trough</a>

## Inserting Oracle Database Appliance X3-2/X4-2/X5-2 and X6-2-HA/X7-2-HA Into a Rack

This section describes how to install the server nodes and storage shelves of Oracle Database Appliance X3-2/X4-2/X5-2 and X6-2-HA/X7-2-HA into a rack.

If you are installing an Oracle Database Appliance X6-2S/X6-2M/X6-2L or X7-2S/X7-2M, see [“Inserting Oracle Database Appliance X6-2S/X6-2M/X6-2L and X7-2S/X7-2M Into a Rack” on page 81](#). If you are installing Oracle Database Appliance Version 1, see [“Inserting Oracle Database Appliance Version 1 Into a Rack” on page 111](#).

This section includes the following subsections:

- [“Contents of the Shipping Pallet” on page 84](#)

- [“Installation Sequence” on page 84](#)
- [“Verify Component Compatibility” on page 85](#)
- [“Tools and Equipment Needed” on page 85](#)
- [“Stabilize the Rack for Installation” on page 86](#)
- [“Applying Labels” on page 86](#)
- [“Installing the Storage Shelves Into a Rack” on page 89](#)
- [“Installing the Server Nodes Into a Rack” on page 110](#)



---

**Caution - Personal injury or equipment damage.** Always install equipment in a rack from the bottom up. See [“Installation Sequence” on page 84](#).

---



---

**Caution - System Failure.** Oracle Database Appliance is shipped with matched sets of components that must be installed together. Mixing components from different systems might cause the system to fail.

---

## Contents of the Shipping Pallet

Oracle Database Appliance X3-2, Oracle Database Appliance X4-2, Oracle Database Appliance X5-2, Oracle Database Appliance X6-2-HA and Oracle Database Appliance X7-2-HA are shipped with the entire system on a single pallet. It includes all server nodes, storage shelves, mounting hardware, cables, and labels.



---

**Caution - System failure.** All items in a shipment are designed to be used together as a single system. Do not mix components from different shipments; this could cause the system to fail. For details, see [“Verify Component Compatibility” on page 85](#).

---

The items in this shipment include:

- Server node 0 and server node 1
- Rackmounting hardware, cables, and labels for server nodes 0 and 1
- One storage shelf
- Rackmounting hardware for the storage shelf

If you ordered a storage expansion shelf, it is shipped separately.

## Installation Sequence

Always install equipment in a rack starting at the bottom and working upwards. For Oracle Database Appliance X3-2, Oracle Database Appliance X4-2, Oracle Database Appliance X5-2,



Oracle Database Appliance X6-2-HA and Oracle Database Appliance X7-2-HA , install the equipment in the following order:

1. Storage expansion shelf, if equipped.
2. Storage shelf.
3. Server node 0.
4. Server node 1.

## ▼ Verify Component Compatibility

For Oracle Database Appliance X3-2, Oracle Database Appliance X4-2, Oracle Database Appliance X5-2, Oracle Database Appliance X6-2-HA and Oracle Database Appliance X7-2-HA, all appliance components that are bundled at the factory have a Top Level Identifier (TLI) number that is matched for the system. Both server nodes, the storage shelf, and the (optional) storage expansion shelf (if included in the initial appliance configuration from the factory), must have the same TLI.

---

**Note** - If you add a storage expansion shelf to the system after the initial installation (that is, the storage expansion shelf was not part of the initial configuration order for the appliance), its TLI will be different from the rest of the system. In this scenario, an add-on component having a different TLI from the main appliance TLI is appropriate.

---

1. **Locate the TLI for both server nodes, the storage shelf, and (if present) the storage expansion shelf.**

The TLI label is on top of the component, on the left-hand side, near the front.

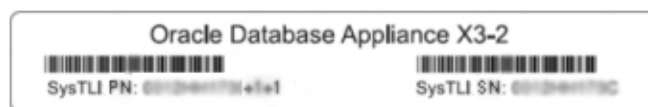

2. **Check to ensure that all components have the same TLI numbers (a TLI part number and TLI serial number).**

## Tools and Equipment Needed

Obtain the following tools and equipment before beginning the installation of Oracle Database Appliance X3-2, Oracle Database Appliance X4-2, Oracle Database Appliance X5-2, Oracle Database Appliance X6-2-HA or Oracle Database Appliance X7-2-HA.

- Phillips head No. 2 screwdriver that is a minimum of 4 inches long
- T20 Torx driver if using a threaded rack
- A mechanical lift is highly recommended



---

**Caution - Personal injury or equipment damage.** The storage shelf weighs approximately 51 lbs (23 kg). If no mechanical lift is available, use three people to place it in the rack.

---

## ▼ Stabilize the Rack for Installation



---

**Caution - Personal injury or equipment damage.** To reduce the risk of personal injury, stabilize the rack cabinet, and extend all anti-tilt devices before installing the server.

---

See your rack documentation for detailed instructions for the following steps.

1. **Open and remove the front and rear doors from the rack cabinet.**

---

**Note** - The front and rear doors need to be removed only if they interfere with the installation.

---

2. **To prevent the rack cabinet from tipping during the installation, fully extend the rack cabinet's anti-tilt legs or anti-tilt bar, which are located at the bottom front of the rack cabinet.**
3. **If there are leveling feet beneath the rack cabinet to prevent it from rolling, extend these leveling feet fully downward to the floor.**

## Applying Labels

Oracle Database Appliance X3-2, Oracle Database Appliance X4-2, Oracle Database Appliance X5-2, Oracle Database Appliance X6-2-HA and Oracle Database Appliance X7-2-HA are shipped with a label kit that provides four labels, to be applied to the front of each server node and storage shelf.

## ▼ To Apply Labels to Server Nodes and Storage Shelves

1. **Find the labels.**

Depending on your model, the shipping kit might include server node labels and a sheet with storage shelve labels.

- Oracle Database Appliance X5-2, Oracle Database Appliance X6-2-HA and Oracle Database Appliance X7-2-HA systems only include server node labels to attach. The storage shelf labels are attached at the factory.
  - Oracle Database Appliance X3-2 and Oracle Database Appliance X4-2 systems include both server node and storage shelf labels that you need to attach.
2. **Verify that the locations where the labels need to go are clean, and free of grease and dirt.**
  3. **Apply the labels where needed:**

For labels that you attach, peel off the backing sheet and apply the label to the corresponding spot on the right-hand side of the appliance front panel.

    - Server Node 1: Apply this label to the top server node [1].
    - Server Node 0: Apply this label to the lower server node [2].
    - Storage shelf: Apply this label to the storage shelf directly beneath server node 0 [3].

- Storage expansion shelf (optional): Apply this label to the bottom storage shelf, if one is present [4].

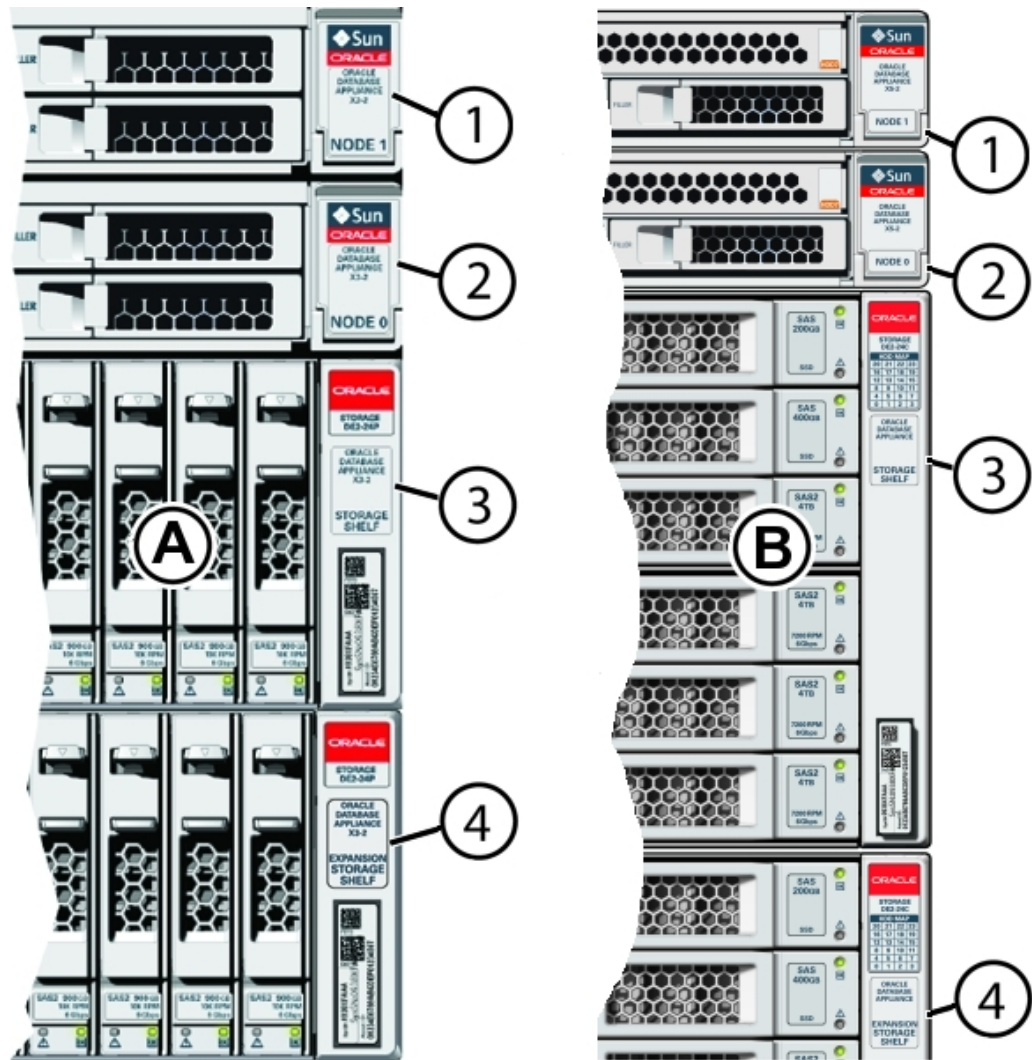

Callout	Description
A	Oracle Database Appliance X3-2 and Oracle Database Appliance X4-2
B	Oracle Database Appliance X5-2, Oracle Database Appliance X6-2-HA and Oracle Database Appliance X7-2-HA
1	Server node 1

Callout	Description
2	Server node 0
3	Storage shelf
4	Optional storage expansion shelf

## Installing the Storage Shelves Into a Rack

This section includes instructions for installing the storage shelf into a rack.

Oracle Database Appliance X3-2, Oracle Database Appliance X4-2, Oracle Database Appliance X5-2, Oracle Database Appliance X6-2-HA and Oracle Database Appliance X7-2-HA require one storage shelf and might include a second storage shelf, called the storage expansion shelf. Both are installed in the same way, with the following caveats:

- If you have a storage expansion shelf, install it first. Follow the procedure for your system:
  - [“Install the Oracle Database Appliance X6-2-HA/X7-2-HA DE3-24C Storage Shelf Into a Rack” on page 89](#)
  - [“Install the Oracle Database Appliance X5-2 DE2-24C Storage Shelf Into a Rack” on page 96](#)
  - [“Install the Oracle Database Appliance X3-2/X4-2 DE2-24P Storage Shelf Into a Rack” on page 101](#)
- If you are adding a storage expansion shelf to an existing system, see [“Add a Storage Expansion Shelf Into an Existing System” on page 110](#) for additional details.

### ▼ Install the Oracle Database Appliance X6-2-HA/X7-2-HA DE3-24C Storage Shelf Into a Rack

The Oracle Storage Drive Enclosure DE3-24C requires four standard mounting units (4RU) of vertical space in the cabinet.

- Before You Begin**
- Ensure that your site meets the requirements in [“Oracle Database Appliance Specifications” on page 61](#)
  - Ensure that the rack meets the requirements in [“Rack Compatibility Requirements” on page 77](#)

---

**Note** - The rail kit included with the shelf can only be used with EIA compliant 9.5 mm square hole racks or 7.0 mm diameter round hole racks.

---

- Observe all precautions in [“Safety Precautions When Rackmounting” on page 76](#)

1. **Starting at the bottom of the cabinet, locate the appropriate rack unit (RU) height.**

Storage shelves must be installed below the server nodes to prevent the rack from tipping.

**2. Open the storage shelf rail kit box and find the cage nut packets included with the kit, and confirm if your rack uses square or round holes.**

The cage nut packets include a special template for either round or square hole racks for positioning the cage nuts.

**Note** - The following steps show rail kit installation with a square hole rack. The same steps would apply for a round hole rack.

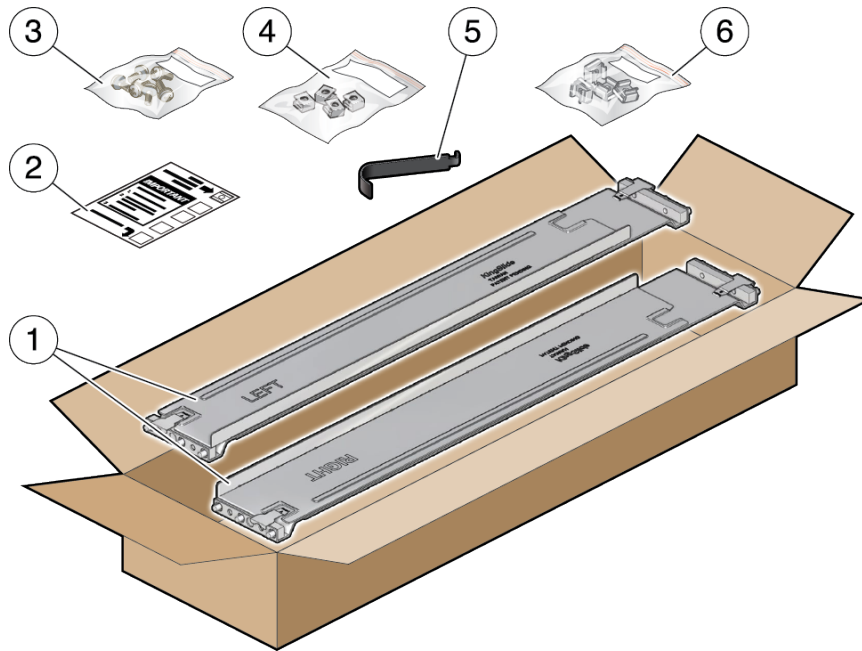

No.	Description
1	Two adjustable storage shelf rails
2	Cage nut installation template
3	Six rear 10-32 7mm shipping screws (2 are spares)
4	Four round 7mm 10-32 cage nuts per set (2 are spares). Only one set is required, either square or round.
5	Cage nut tool
6	Four square 9.5mm 10-32 cage nuts per set (2 are spares). Only one set is required, either square or round.

3. **Attach the storage shelf rails to the rack, as follows:**
  - a. **Orient the rail so that the stamped label (LEFT or RIGHT) is facing the inside of the rack.**
  - b. **Adjust the rail length to fit the front and rear of the rack.**

---

**Note** - Mark which rack rail holes you will be using to ensure the storage shelf rails are installed evenly and correctly the first time.

---

- c. **Hold open the rail clamp at each end of the rail by pressing the clamp lever [1] and insert both ends of the rail into the appropriate rack holes [2].**

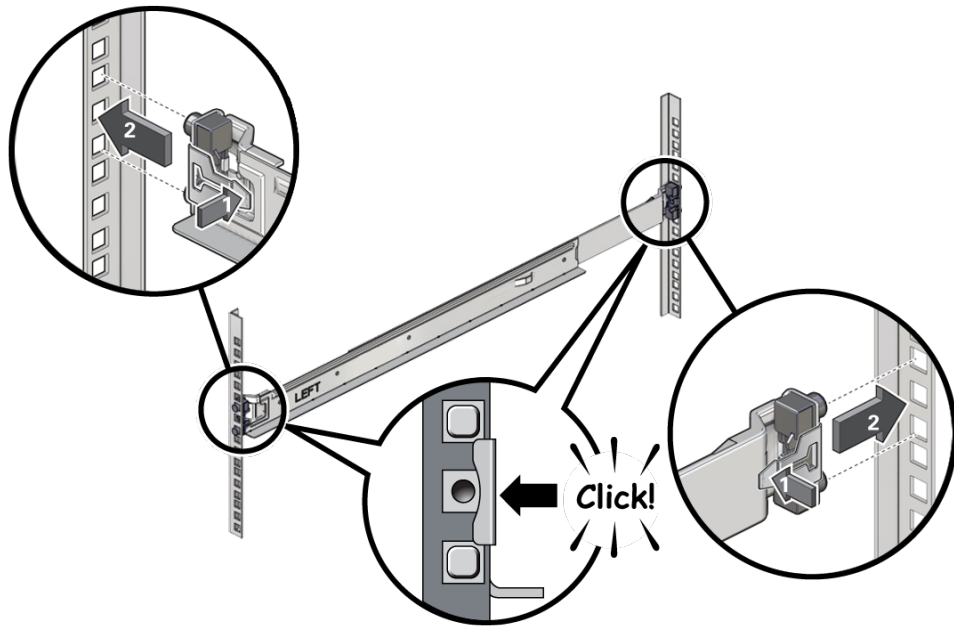

- d. **Close the rail clamps over the rails by releasing the clamp lever.**  
You will hear an audible click as the clamps lock in place over the rack rails.
- e. **Repeat steps 3a through 3d for the second rail.**

4. **Install one screw through the rack and into the rear of each rail.**

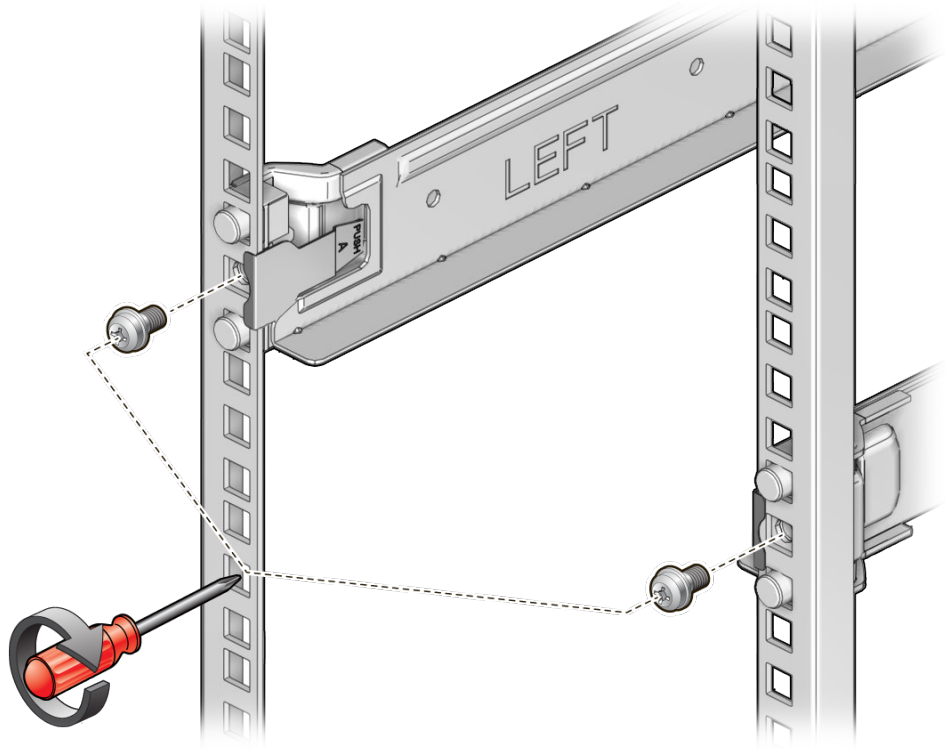

5. **Install the front cage nuts.**





**Caution** - Installing the storage shelf without the front cage nuts will cause the storage shelf to be unstable. You would then need to remove the storage shelf from the rack to install the cage nuts.

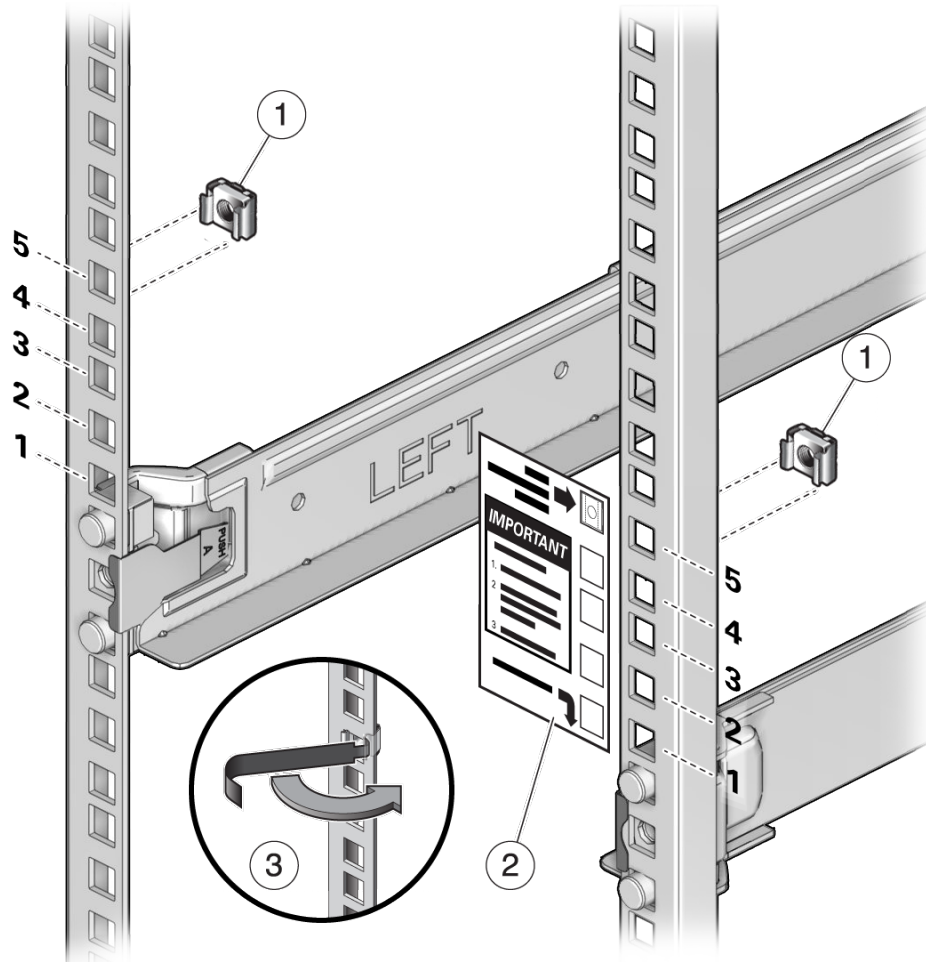

No.	Description
1	Cage nuts
2	Cage nut installation template
3	Cage nut tool

- a. Use the template [2] to determine cage nut placement.
  - b. Retrieve a cage nut and hook one lip of the nut into the appropriate rail hole [1].
  - c. Insert the tip of the cage nut insertion tool through the rail hole [3] and hook the other lip of the cage nut. Pull the cage nut through the hole until the lip snaps into place.
  - d. Repeat through steps 5a through 5c for the second cage nut.
6. Using a mechanical lift or three people, one at each side of the storage shelf and one in front, carefully lift and rest the shelf on the bottom ledge of the left and right rails. Do not lift using the power supply handles.

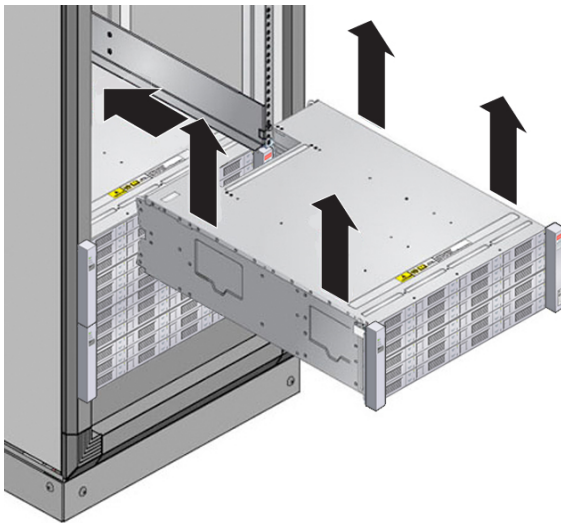

7. Carefully slide the shelf into the cabinet. Ensure that the shelf is fully seated within the rails. If removing the shelf to reset it, support it at all times.

- Secure the front of the shelf using the four captive securing screws [1 - 4].

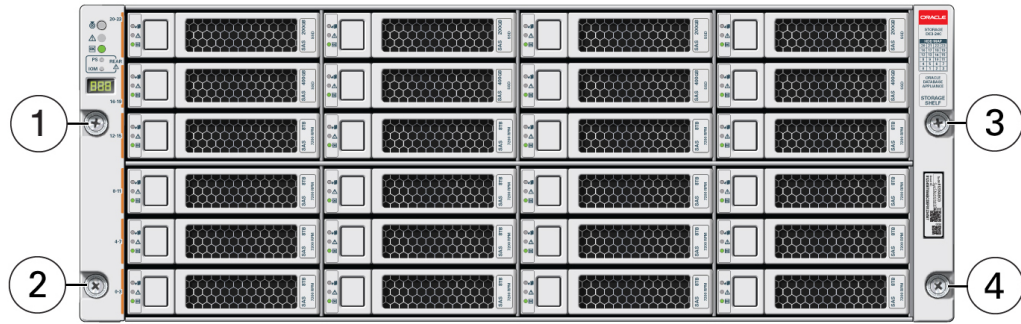

9. To secure the storage shelf in the rack for shipping, install a screw in each rear storage shelf chassis ear.

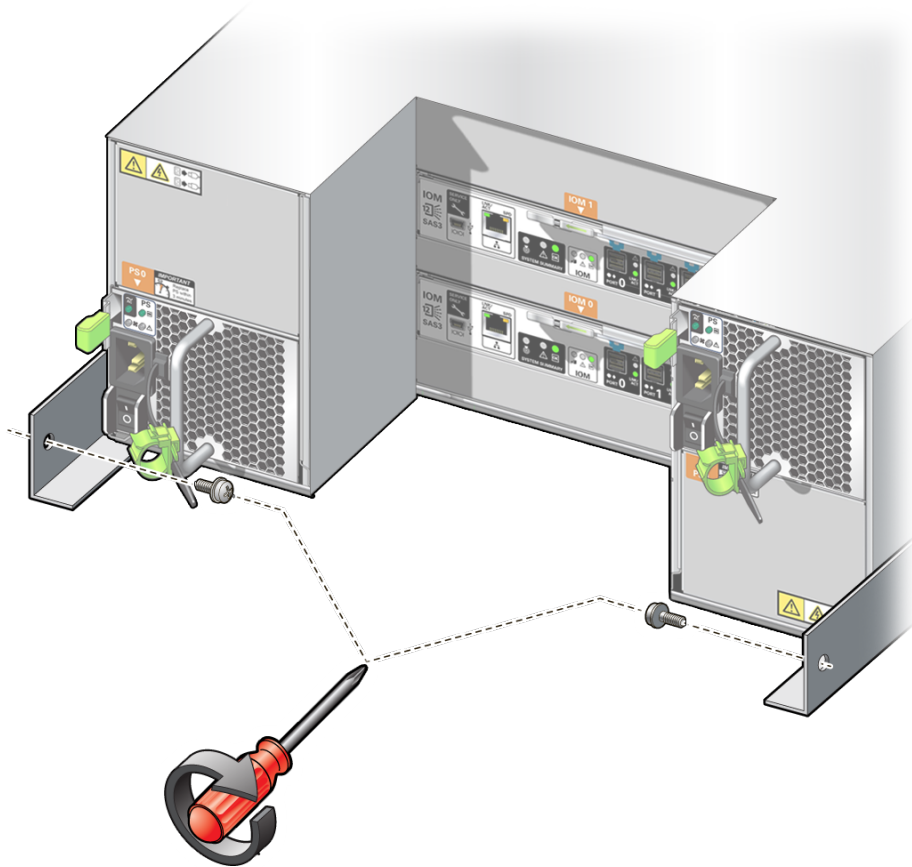

10. Repeat these steps if you have an additional storage shelf to install.

### ▼ Install the Oracle Database Appliance X5-2 DE2-24C Storage Shelf Into a Rack

The Oracle Storage Drive Enclosure DE2-24C requires four standard mounting units (4RU) of vertical space in the cabinet. Starting at the bottom of the cabinet, locate the appropriate rack unit (RU) height. Install storage shelves below controllers to prevent the rack from tipping.

**Before You Begin** This task provides instructions for both threaded and unthreaded racks.

- Ensure that your site meets the requirements in [“Oracle Database Appliance Specifications” on page 61](#)
  - Ensure that the rack meets the requirements in [“Rack Compatibility Requirements” on page 77](#)
  - Observe all precautions in [“Safety Precautions When Rackmounting” on page 76](#)
1. **If using an unthreaded universal 19-inch or Sun Rack II cabinet, snap one supplied cage nut into the 8th rack hole, counting upward, in each front rail of the 4RU space.**

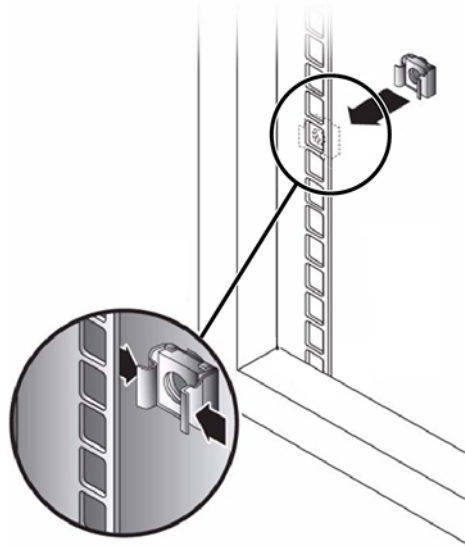

2. **Prepare the screws in each rail end:**
  - Square-hole unthreaded cabinet: No preparation.
  - Round-hole unthreaded cabinet: Remove the screws from each rail end and discard. Locate the screws for round-hole cabinets and place aside.
  - Threaded cabinet: Remove screws and replace them in the opposite direction (from the inside of the rail flange) so they act as location pins. Also remove the clip nut from each front rail end and discard.
3. **Position the front of the rails inside the cabinet, with the rail flange inside of the cabinet flange, and the rail label facing the inside of the cabinet.**
  - Square-hole unthreaded cabinet: The screw heads fit inside the rack holes.

- Round-hole unthreaded cabinet: Install two screws through the rack and into the front of each rail. Do not install into the cage nut in the rack, or the clip nut on the rail.
- Threaded cabinet: The location pins fit inside the rack holes.

**4. Adjust the rail lengths to fit.**

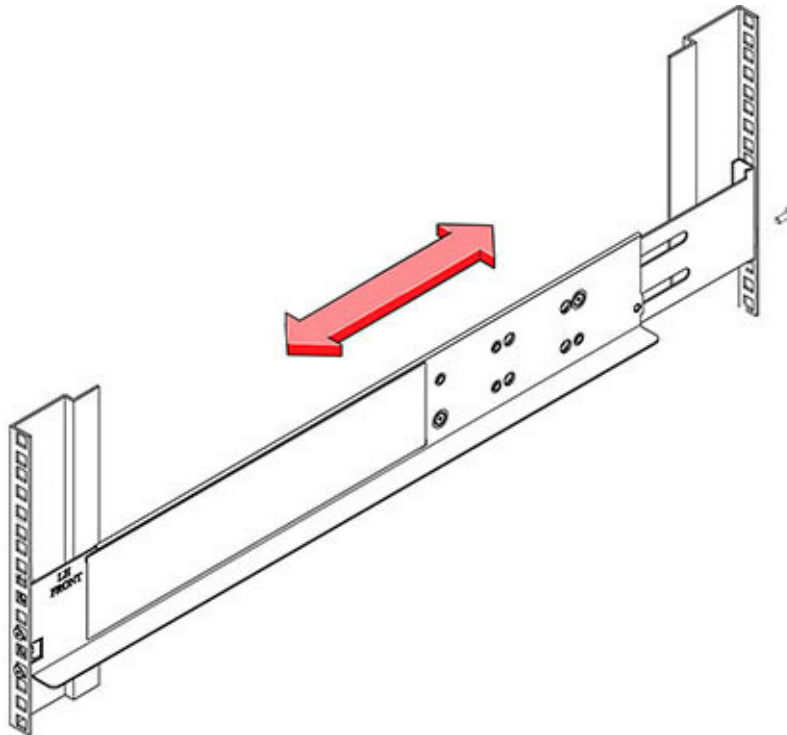

**5. Install one screw through the rack and into the rear of each rail.**

6. Tighten the two locking screws in the rails.

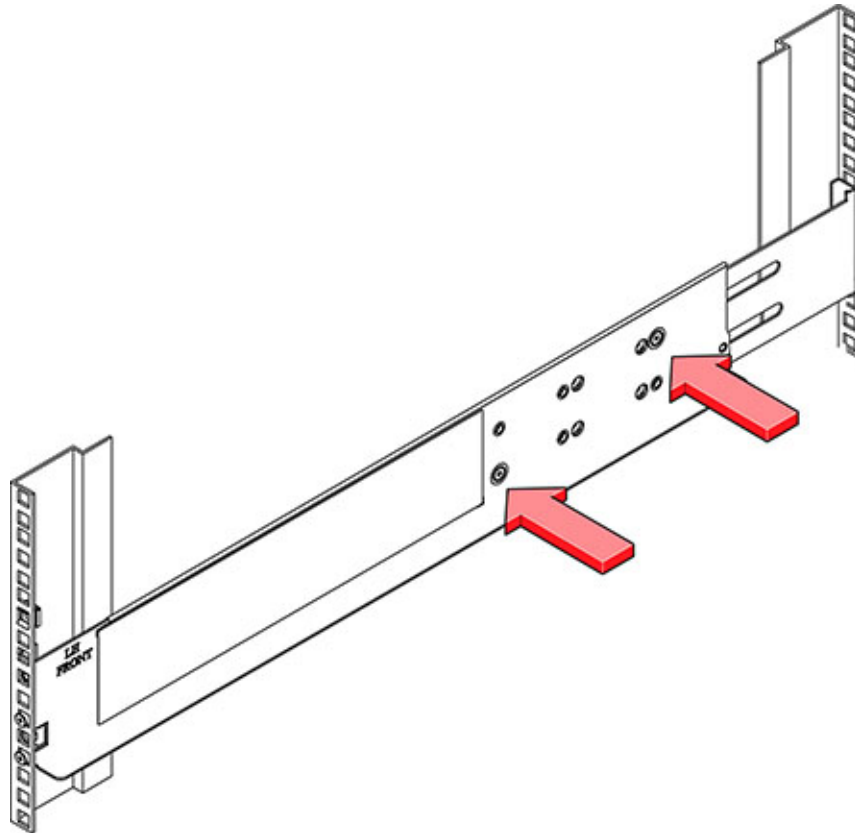

7. **Using a mechanical lift or three people, one at each side of the storage shelf and one in front, carefully lift and rest the shelf on the bottom ledge of the left and right rails. Do not lift using the power supply handles.**

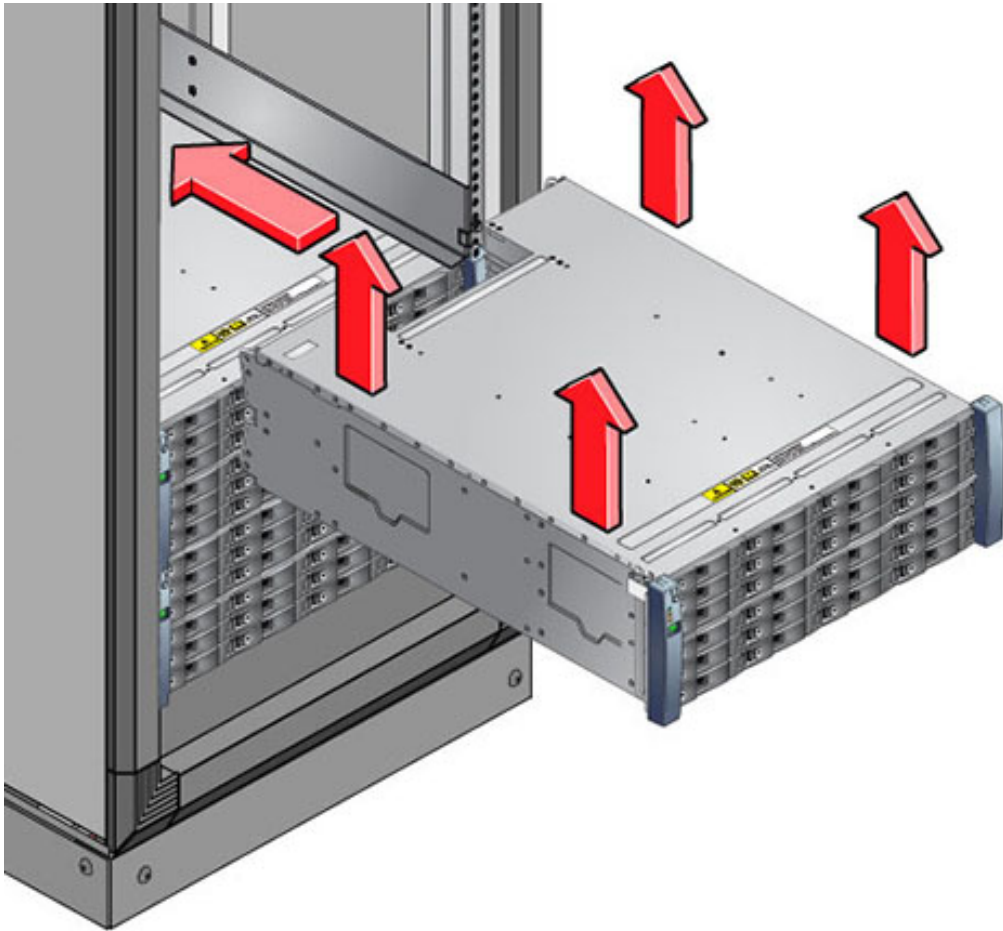

8. **Carefully slide the shelf into the cabinet. Ensure that the shelf is fully seated within the rails. If removing the shelf to reseal it, support it at all times.**
9. **Remove the front side caps, install two screws into each front side, and replace the caps.**



10. **Install one long patchlock screw per rail to secure the rear of the shelf to the rear of the rack.**

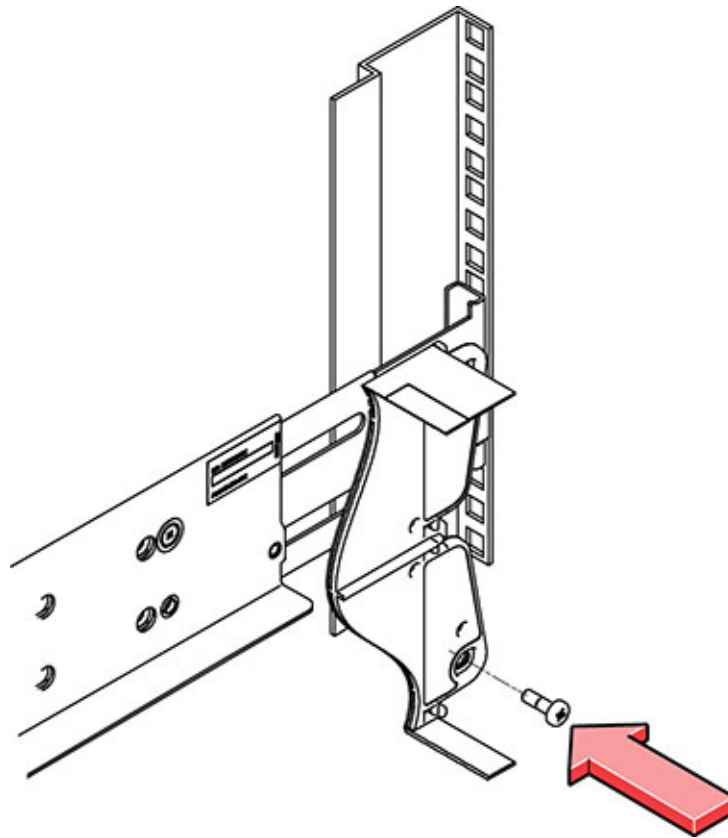

11. **Repeat these steps if you have an additional storage shelf to install.**

### ▼ **Install the Oracle Database Appliance X3-2/X4-2 DE2-24P Storage Shelf Into a Rack**

The Oracle Storage Drive Enclosure DE2-24P requires two standard mounting units (2RU) of vertical space in the cabinet. The storage shelf rack-mount kit contains two rack rails, long and short M6 screws, and a 10mm wrench.

**Before You Begin** This task provides instructions for both threaded and unthreaded racks.

- Ensure that your site meets the requirements in [“Oracle Database Appliance Specifications” on page 61](#)

- Ensure that the rack meets the requirements in [“Rack Compatibility Requirements” on page 77](#)
- Observe all precautions in [“Safety Precautions When Rackmounting” on page 76](#)

**1. Install the rails in the rack.**

- **If you have an unthreaded rack:**
  - a. **Position the front rail location pegs [1] fully inside the appropriate holes in the front of the rack.**

The rail flange [2] must be inside of the cabinet flange, and the rail label facing the inside of the cabinet.
  - b. **Insert and loosely tighten one screw through the front of the rack and into the top hole in the rails [3].**

- c. Insert and loosely tighten one screw through the back of the rack and into the back of the rails [4].

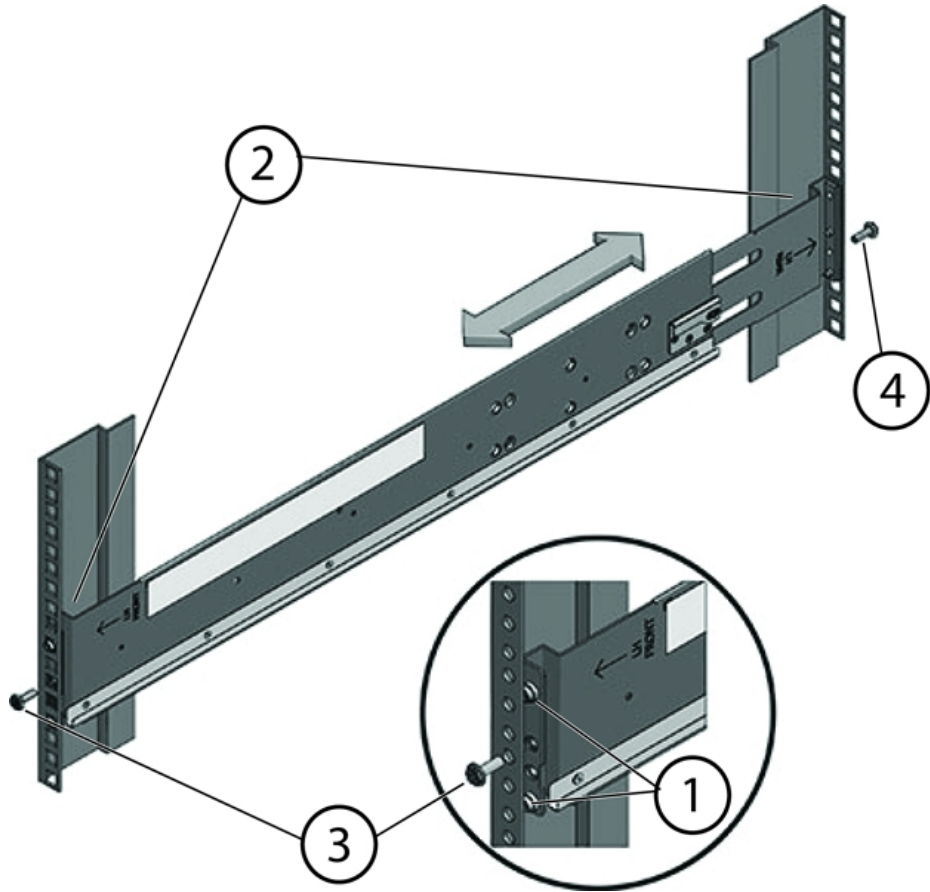

Callout	Description
1	Location pegs
2	Rail flange and label
3	Front mounting screw
4	Rear mounting screw

- If you have a threaded rack:

- a. **Use the T20 Torx driver to remove the rail location pegs from the front and rear of the rails [1].**
- b. **Use a 10mm wrench (supplied) to insert the pins into the ends of the rails where you removed the location pegs [1].**
- c. **Position the front of the rails inside the cabinet, with the rail flange inside of the cabinet flange, and the rail label facing the inside of the cabinet [2].**

The pins should be fully located within the rack holes.

- d. **Insert and loosely tighten one screw through the front of the rack and into the top hole in the rails [3].**

The screws for threaded racks have an unthreaded area near the top of the shaft. Before threading these screws into the rails, thread them through the rack until the threads clear the rack and the screws turn freely.



**Caution - Mechanical failure.** When installing a storage shelf in a threaded rack, be sure to use the screws with the partially unthreaded shaft. Before threading them into the rails, be sure to thread them through the rack until the threads clear the rack and the screws turn freely.

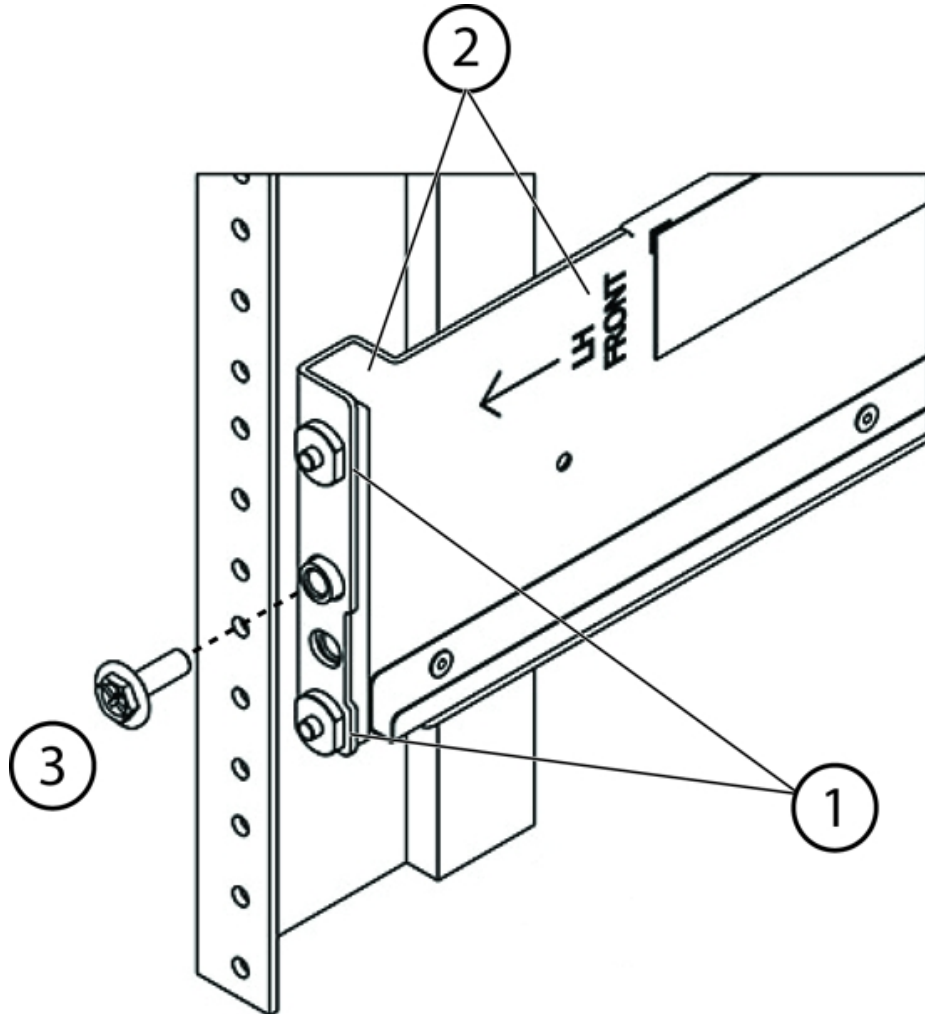

Callout	Description
1	Pins (these replaced the location pegs)
2	Rail flange and label

Callout	Description
3	Front mounting screw

- e. **Adjust the rail lengths to fit, and locate the rear pins inside the corresponding rear rack holes [1].**
- f. **Insert and loosely tighten one screw through the back of the rack and into the back of the rails [2].**

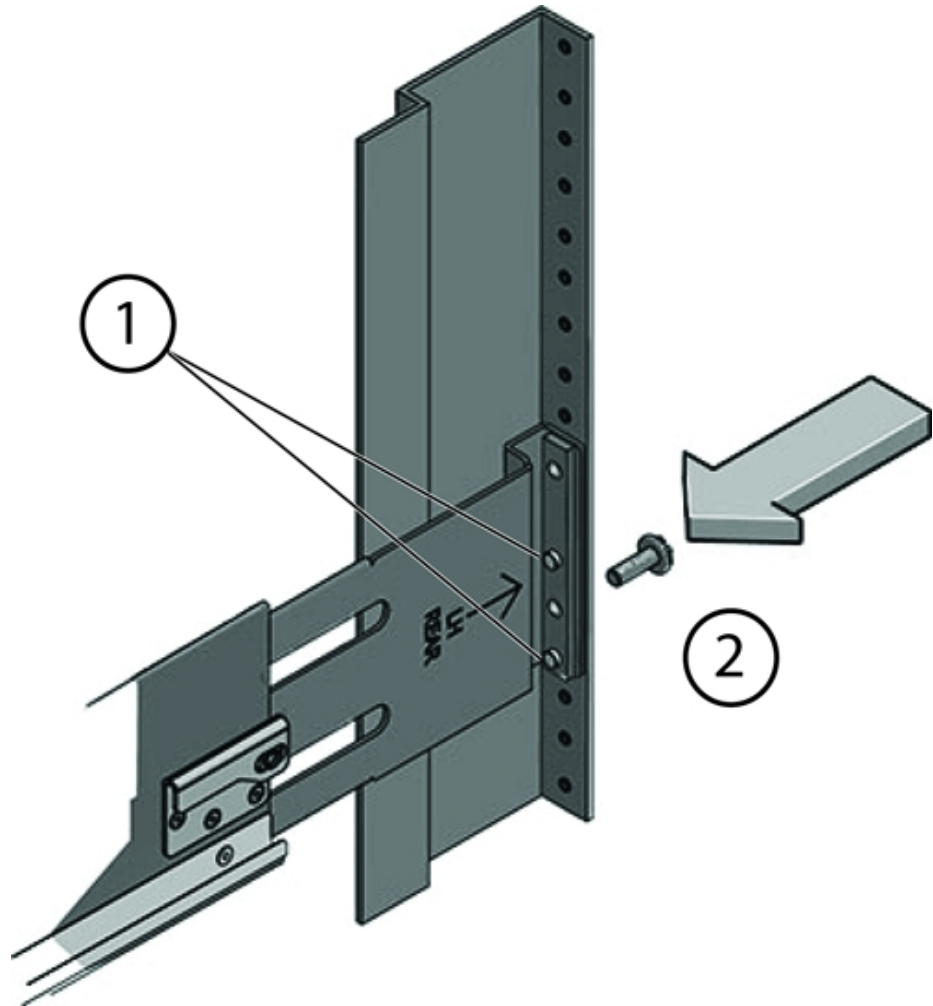

Number	Description
1	Pins (replace location pegs)
2	Rear mounting screw

2. **Carefully slide the storage shelf onto the shelf rails until it is fully seated in the rack.**



---

**Caution - Equipment damage.** Do not lift the storage shelf using the handles on the power supply/fan module.

---



---

**Caution - Personal injury or equipment damage.** Use a mechanical lift, or three persons. If you are using three persons, use two to lift the storage shelf into place, and a third to check that it is resting securely on the rails before releasing it.

---

3. **Pull the storage shelf partway out of the rack until it is approximately 7.8 inches (200 mm) out of the rack.**
4. **Tighten the four screws that fasten the rails to the rack (two in front, two in back).**

5. **Slide the storage shelf back into the rack and check to ensure that it is resting securely on the rails.**

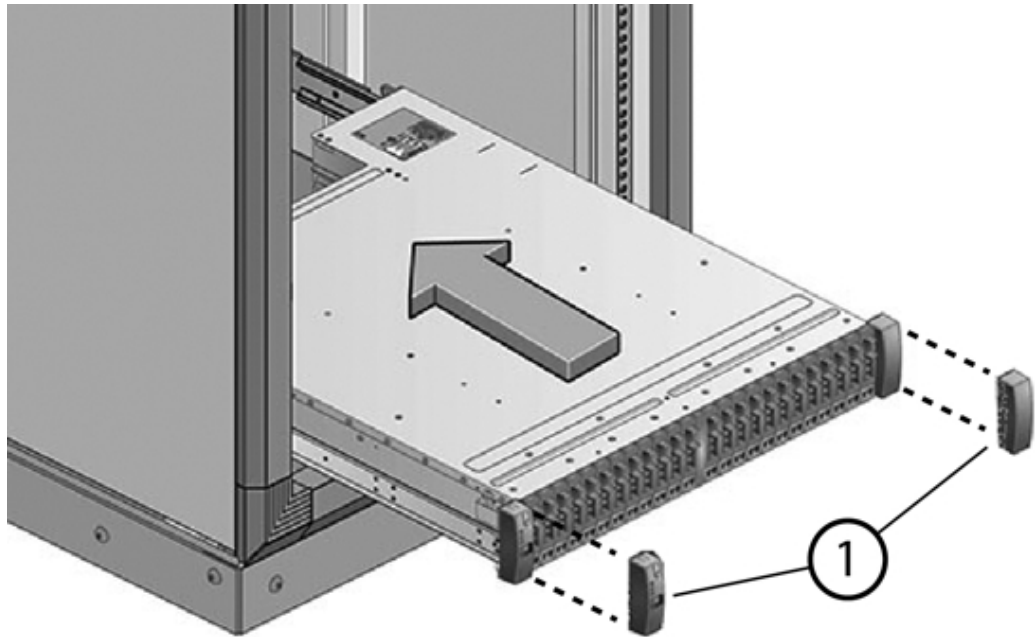

6. **Remove the front end caps that cover the ears on the front of the storage shelf [1]. They snap off.**
7. **Use one short screw on each side to fasten the front of the storage shelf to the rack.**
8. **Snap the end caps back onto the storage shelf.**



9. Use one short screw per rail to secure the rear of the storage shelf to threaded hole on the rail.

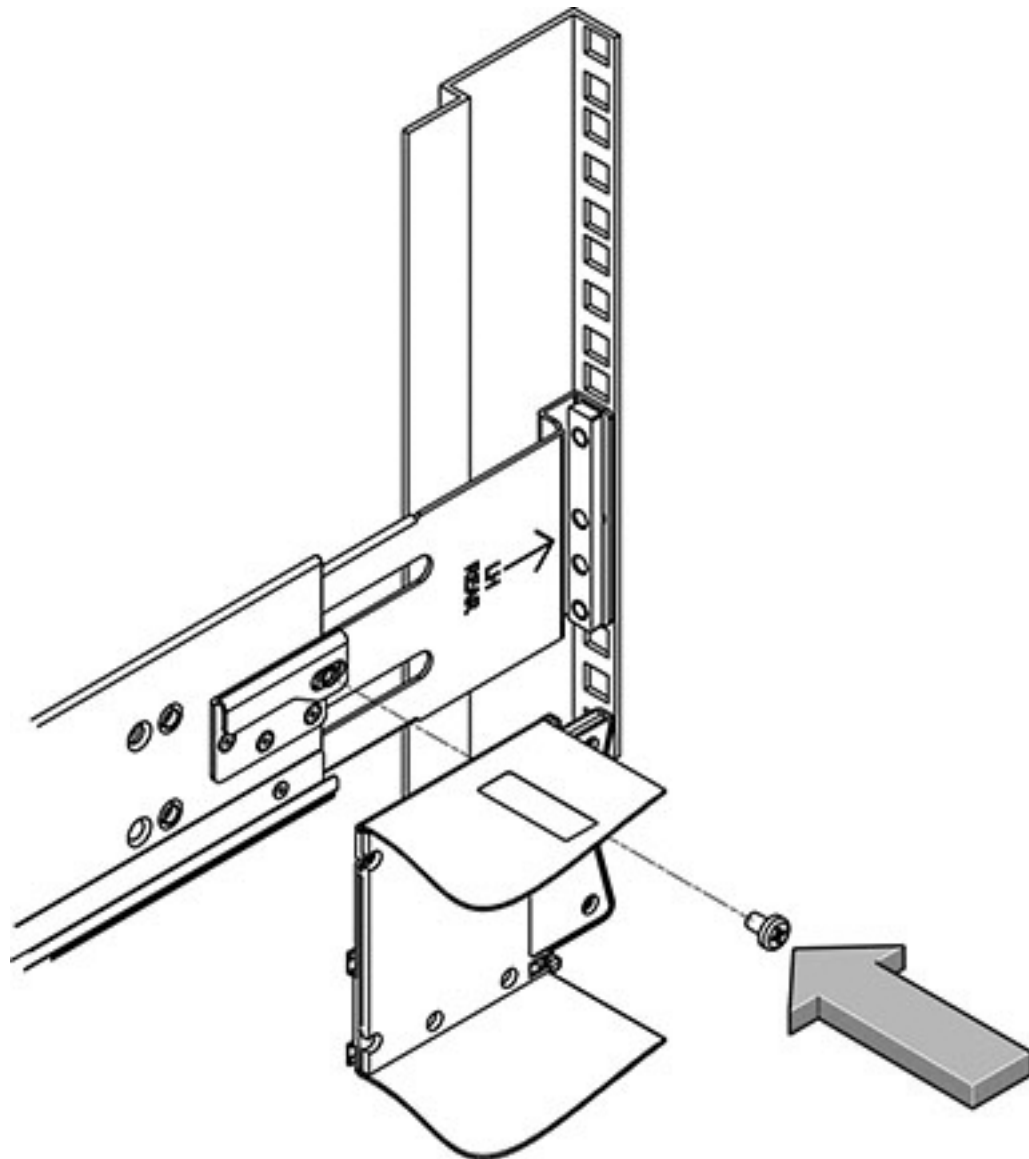

10. Repeat these steps if you have an additional storage shelf to install.

## ▼ Add a Storage Expansion Shelf Into an Existing System

**Before You Begin** This task assumes that you are adding a storage expansion shelf to an already running Oracle Database Appliance X3-2, Oracle Database Appliance X4-2, Oracle Database Appliance X5-2, or Oracle Database Appliance X6-2-HA (must already have a fully populated storage shelf).

It is not necessary to shut down your system to complete this task.

Please note the following exceptional conditions:

- The storage expansion shelf normally sits at the bottom of Oracle Database Appliance, beneath the storage shelf. However, since racks should always be provisioned from the bottom up, that space might be unavailable. In these cases, to avoid re-rackmounting the entire system, it can be placed above the server nodes, or even in a different rack.
- The Top Level Identifier (TLI) on the storage expansion shelf will not match the rest of the system as described in [“Verify Component Compatibility” on page 85](#). However, adding a storage expansion shelf after your initial purchase and setup of the appliance is a supported configuration.

**1. Apply the label, if needed.**

The expansion storage shelf shipment includes a label that says "EXPANSION STORAGE SHELF". If the label is not already applied to the front of the shelf, apply it now as described in [“Applying Labels” on page 86](#).

**2. Install the expansion storage shelf as described in [“Installing the Storage Shelves Into a Rack” on page 89](#).**

**3. Cable, power-on, and verify that the new storage is added.**

Refer to the appropriate *Getting Started Guide* or *Deployment and User's Guide* for additional information.

## Installing the Server Nodes Into a Rack

Use the instructions in this section to install server nodes in the rack.

**Installing the Oracle Database Appliance X6-2-HA or X7-2-HA server nodes into the rack:**

---

**Note** - The links in the following table take you to instructions *outside* of the Oracle Database Appliance library to the Oracle Server X6-2 and Oracle Server X7-2 documentation libraries. Use your browser's Back button to return to the Oracle Database Appliance library.

---

Oracle Database Appliance X6-2-HA	Oracle Database Appliance X7-2-HA
■ <a href="#">Verify Rackmount Hardware</a>	■ <a href="#">Verify Rackmount Hardware</a>

Oracle Database Appliance X6-2-HA	Oracle Database Appliance X7-2-HA
<ul style="list-style-type: none"> <li>■ <a href="#">Install Mounting Brackets</a></li> <li>■ <a href="#">Mark the Rackmount Location</a></li> <li>■ <a href="#">Connect AC Power Cables Before Installing Tool-less Slide-Rails in Sun Rack II 1042</a></li> <li>■ <a href="#">Attach the Tool-less Slide-Rail Assemblies</a></li> <li>■ <a href="#">Install the Server into the Slide-Rail Assemblies</a></li> <li>■ <a href="#">Install the Cable Management Arm and Verify Operation</a></li> <li>■ <a href="#">Optional: Install the Shipping Bracket With Cable Trough</a></li> </ul>	<ul style="list-style-type: none"> <li>■ <a href="#">Install Mounting Brackets</a></li> <li>■ <a href="#">Mark the Rackmount Location</a></li> <li>■ <a href="#">Connect AC Power Cables and Slide-Rails</a></li> <li>■ <a href="#">Attach the Tool-less Slide-Rail Assemblies</a></li> <li>■ <a href="#">Install the Server into the Slide-Rail Assemblies</a></li> <li>■ <a href="#">Install the Cable Management Arm and Verify Operation</a></li> </ul>

### Installing the Oracle Database Appliance X3-2/X4-2/X5-2 server nodes into the rack:

**Note** - The links in the following table take you to instructions *outside* of the Oracle Database Appliance library to the Sun Server X3-2, Sun Server X4-2, Oracle Server X5-2 documentation libraries. Use your browser's Back button to return to the Oracle Database Appliance library.

Oracle Database Appliance X3-2	Oracle Database Appliance X4-2	Oracle Database Appliance X5-2
<ul style="list-style-type: none"> <li>■ <a href="#">Verify Rackmount Hardware</a></li> <li>■ <a href="#">Install Mounting Brackets</a></li> <li>■ <a href="#">Mark the Rackmount Location</a></li> <li>■ <a href="#">Attach the Tool-less Slide-Rail Assemblies</a></li> <li>■ <a href="#">Install the Server into the Slide-Rail Assemblies</a></li> <li>■ <a href="#">Install the Cable Management Arm and Verify Operation</a></li> </ul>	<ul style="list-style-type: none"> <li>■ <a href="#">Verify Rackmount Hardware</a></li> <li>■ <a href="#">Install Mounting Brackets</a></li> <li>■ <a href="#">Mark the Rackmount Location</a></li> <li>■ <a href="#">Attach the Tool-less Slide-Rail Assemblies</a></li> <li>■ <a href="#">Install the Server into the Slide-Rail Assemblies</a></li> <li>■ <a href="#">Install the Cable Management Arm</a></li> <li>■ <a href="#">Verify Operation of Slide Rails and CMA</a></li> </ul>	<ul style="list-style-type: none"> <li>■ <a href="#">Verify Rackmount Hardware</a></li> <li>■ <a href="#">Install Mounting Brackets</a></li> <li>■ <a href="#">Mark the Rackmount Location</a></li> <li>■ <a href="#">Connect AC Power Cables Before Installing Tool-less Slide-Rails in Sun Rack II 1042</a></li> <li>■ <a href="#">Attach the Tool-less Slide-Rail Assemblies</a></li> <li>■ <a href="#">Install the Server into the Slide-Rail Assemblies</a></li> <li>■ <a href="#">Install the Cable Management Arm and Verify Operation</a></li> <li>■ <a href="#">Optional: Install the Shipping Bracket With Cable Trough</a></li> </ul>

## Inserting Oracle Database Appliance Version 1 Into a Rack

This section describes inserting Oracle Database Appliance Version 1 into a rack.

If you are installing an Oracle Database Appliance X6-2S/X6-2M/X6-2L or X7-2S/X7-2M, see [“Inserting Oracle Database Appliance X6-2S/X6-2M/X6-2L and X7-2S/X7-2M Into a Rack” on page 81](#). If you are installing an Oracle Database Appliance X3-2/X4-2/X5-2 or

X6-2-HA/X7-2-HA, see [“Inserting Oracle Database Appliance X3-2/X4-2/X5-2 and X6-2-HA/X7-2-HA Into a Rack”](#) on page 83.

This section includes the following subsections:

- [“Rackmount Kit Contents”](#) on page 112
- [“Staff, Tools, and Equipment Required to Rackmount the System”](#) on page 114
- [“Removing Components to Reduce System Weight”](#) on page 114
- [“Install Rackmount Hardware Into a Rack”](#) on page 115
- [“Install the System Into a Rack”](#) on page 122
- [“Installing Shipping Brackets”](#) on page 126

---

**Note** - If you are going to use a mechanical lift, you do not need to perform this procedure.

---

---

**Note** - The system chassis is fixed in the rack by the rack-mounting kit hardware. The rack-mounting kit does not include slide rails. After the system chassis is installed in the rack, it does not slide in or out of the rack. The server nodes (also called system controllers) can be removed from the chassis while the chassis is installed in the rack.

---

## Rackmount Kit Contents

The Rackmount Kit contains the hardware required to install Oracle Database Appliance Version 1 into a supported rack. The Rackmount Guide and Alignment Template is shipped with the system in the shipping kit. Use this template when you are installing the system into the rack.

---

**Note** - The rackmount kit does *not* include slide rails. After the system is installed, it does not slide in or out of the rack. See the Rackmount Guide and Alignment Template for additional instructions on how to install your system into a four-post rack.

---

The following figure shows the hardware that comes with the rackmount kit.

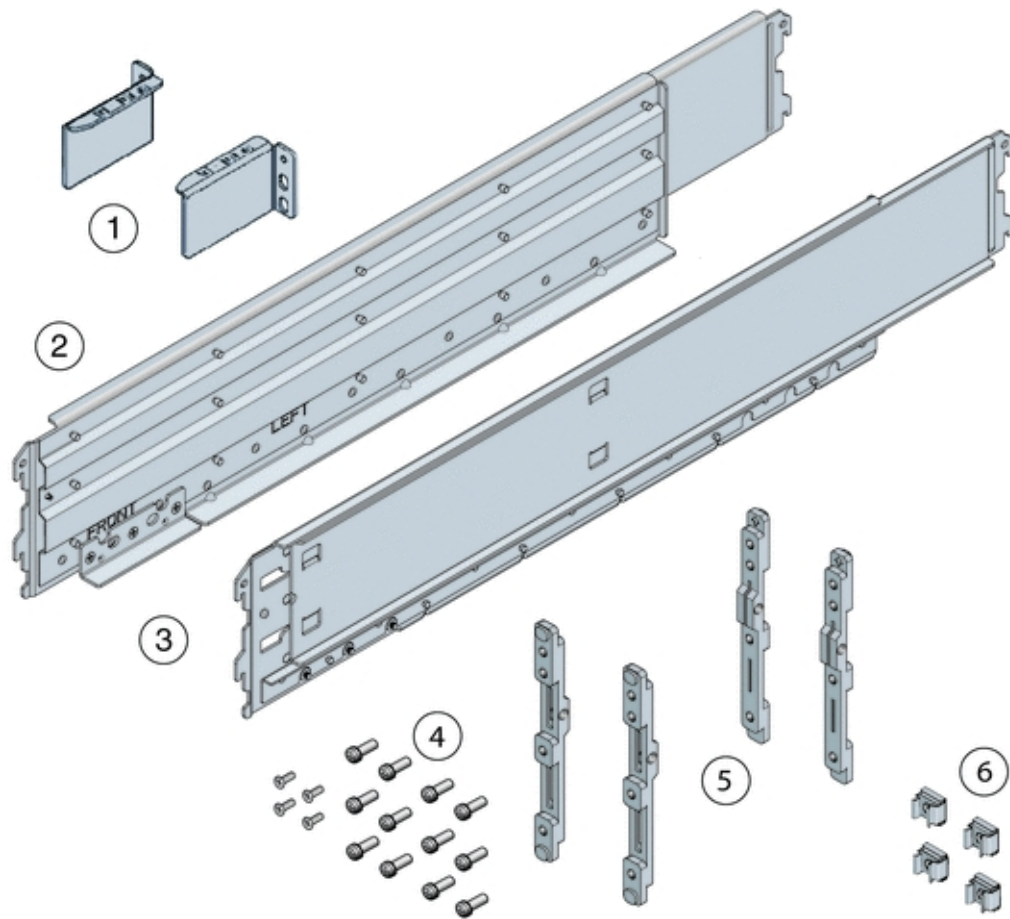

Callout	Description
1	Top rear braces that attach to the posts at the upper rear of the system.
2	Left shelf rail.
3	Right shelf rail.
4	An assortment of M6 and 10-32 screws, including twelve M6 x 16 screws, twelve M6 x 12 screws, four M6 x 4 flathead screws, ten 10-32 screws, and twelve 10-32 shoulder screws.
5	Two sets of four adapter brackets, one set for round-hole racks, and one set for square-hole racks.
6	Four M6 cage nuts. <b>Note</b> - The cage nuts are not used. You can recycle them.

## Staff, Tools, and Equipment Required to Rackmount the System



**Caution - Personal injury or equipment damage.** Use a mechanical lift to install the system or follow the precautions in [“Removing Components to Reduce System Weight” on page 114](#).

---

Before starting the installation, gather the staff, tools, and equipment required to rackmount the system.

Staff, Tools, and Equipment	Notes
Four trained staff	Four people are needed to lift or transport the system. <b>Note</b> - If a mechanical lift is available or components have been removed from the system, it is safe for two people to lift or transport the system.
No. 2 10-inch Phillips screwdriver	A magnetic tip is recommended.
Mechanical lift	Strongly recommended. If not available, reduce the weight of the system. See <a href="#">“Removing Components to Reduce System Weight” on page 114</a> .
Compatible four-post rack	See <a href="#">“Rack Compatibility Requirements” on page 77</a> .
Rackmount kit	See <a href="#">“Rackmount Kit Contents” on page 112</a> .
Transportation kit	See <a href="#">“Transportation Kit Contents” on page 127</a> .
Antistatic wrist strap and antistatic mat	Required only if you remove system components.

## Removing Components to Reduce System Weight

Before installing Oracle Database Appliance Version 1 into a rack, you can remove components to reduce the weight of the system so that two persons can lift the system into the rack. Removing system components reduces the weight to approximately 96 pounds (43.5 kg).

Remove the following components to reduce the system weight:

- Server nodes
- Power supplies

---

**Note** - Because of their light weight, you do not need to remove filler panels from the system.

---

For instructions on removing components from the system and associated safety information, see the *Oracle Database Appliance Service Manual*.

## ▼ Install Rackmount Hardware Into a Rack

Oracle Database Appliance Version 1 rack-mounting hardware consists of shelf rails, front and rear adapter brackets, rear braces, and screws.



---

**Caution - Personal injury or equipment damage.** Use a mechanical lift to install the system, or follow the precautions in [“Removing Components to Reduce System Weight” on page 114](#). Removing components reduces the weight from 160 pounds (72.6 kg) when fully loaded with components to approximately 96 pounds (43.5 kg).

---



---

**Caution - Tip hazard.** Always load equipment into a rack from the bottom up so that it does not become top-heavy and tip over. Deploy your rack’s anti-tilt bar to prevent the rack from tipping during installation.

---



---

**Caution - Elevated operating ambient temperature.** Install this equipment in an environment that does not exceed the maximum ambient temperature (T<sub>ma</sub>) specified in [“Environmental Specifications” on page 65](#). If the system is installed in a closed or multi-unit rack assembly, then the operating ambient temperature of the rack environment might be greater than room ambient temperature.

---



---

**Caution - Thermal damage.** Install the equipment in a rack so that the airflow is not restricted.

---



---

**Caution - Circuit overloading.** Consider the connection of the equipment to the supply circuit and the effect that overloading of the circuits might have on overcurrent protection and supply wiring. Be aware of equipment nameplate power ratings when addressing this concern.

---



---

**Caution - Equipment damage.** Maintain reliable grounding of rack-mounted equipment. Pay attention to supply connections other than direct connections to the branch circuit (for example, use of power strips).

---

1. **Use the *Rackmount Guide and Alignment Template* to measure the 4 rack unit (4RU) space in the rack where you will install the system.**

Also, use that template to align the adapter brackets with the rack posts.

2. **Verify that you have a 4RU space in your rack.**

Place the bottom edge of the *Rackmount Guide and Alignment Template* in the lowest available position in the rack. Align all arrows with holes on the rack post. Ensure that 4RU space is available in the rack.

3. **Select the adapter brackets that match your rack.**

The system ships with two sets of adapter brackets: one set [1] for racks with square holes and one set [2] for racks with round holes.

The adapter brackets are labeled to indicate whether they are for square-hole racks or round-hole racks. Additionally, arrows on the adapter brackets indicate how they should be oriented. Install all brackets with the arrow labeled "Top" pointing up.

**4. Attach the adapter brackets to the front rack posts.**

The following figure shows the front adapter brackets being attached to a square-hole rack [1] and a round-hole rack [2].

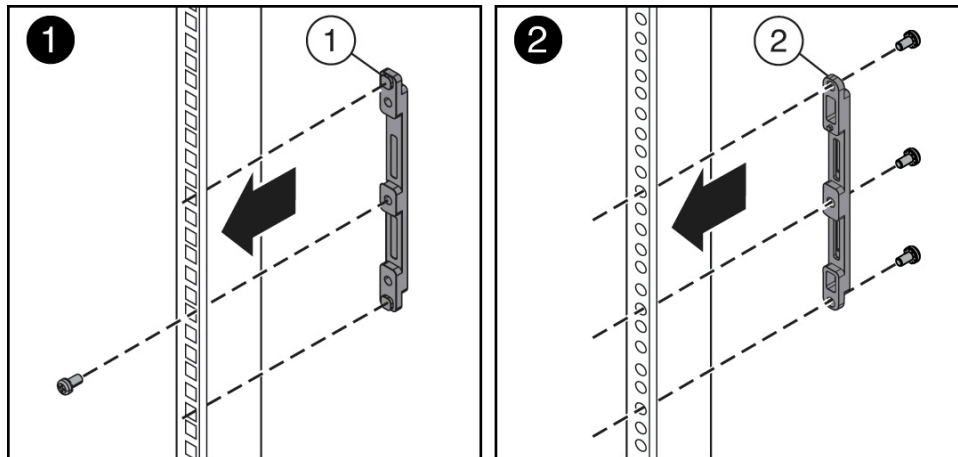

- a. Place the brackets so that the bracket is aligned with the 4RU space where the server will be installed, and verify that the arrow labeled "Top" on the brackets points up.
- b. Select the screws that match your rack.
  - For a square-hole rack, use one M6 x 12 mm screw per adapter bracket.
  - For a threaded round-hole rack, use three M6 x 12 mm screws, or three 10-32 shoulder screws per adapter bracket.

**5. Attach the adapter brackets to the rear rack posts.**

- a. Place the brackets so that the bracket is aligned with the space where the server will be installed and verify that the arrow labeled "Top" on the brackets points up.
- b. Select the screws that match your rack.



- For a square-hole rack, use two M6 x 12 mm screws per adapter bracket.
- For a threaded round-hole rack, use two M6 x 12 mm screws or two 10-32 shoulder screws per adapter bracket.

The following figure shows the rear adapter brackets being attached to a round-hole rack.

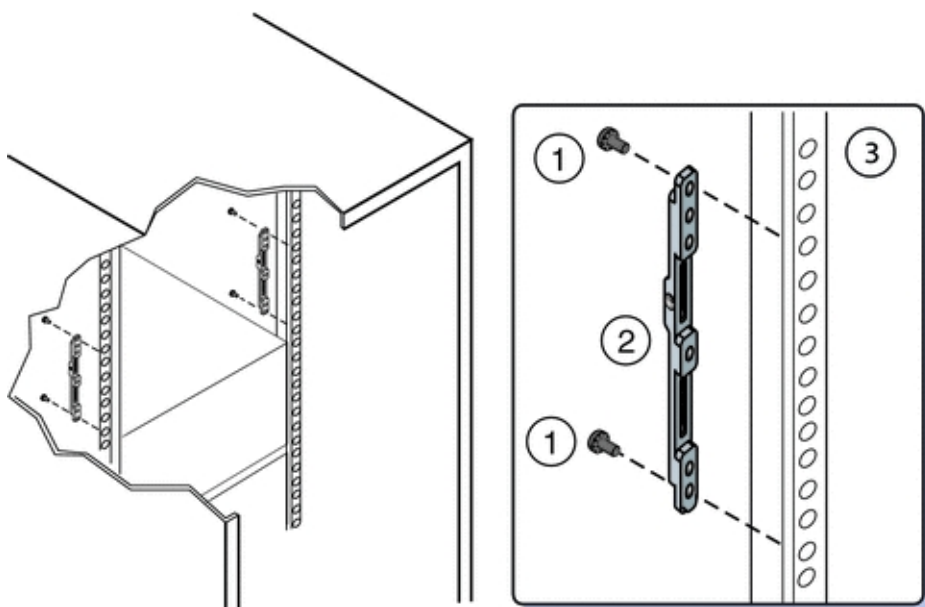

The following figure shows the rear adapter brackets being attached to a square-hole rack.

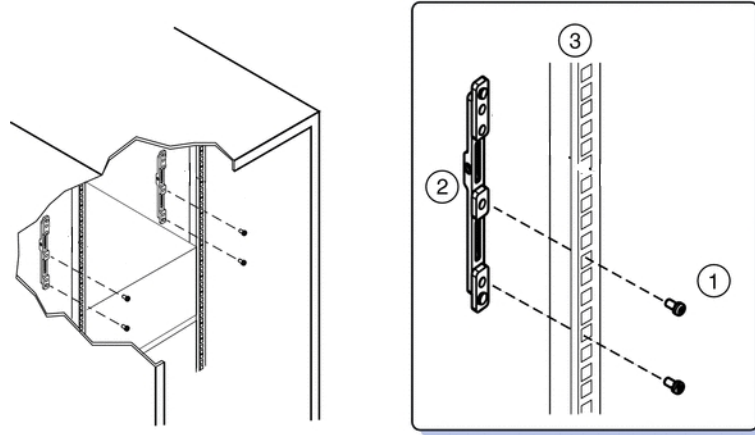

6. **Attach rear braces to the rear rack posts and to the adapter brackets.**
  - a. **Position the rear braces so that the tops of the braces [1] align with the 4U mark on each rear rack post.**

- b. Install two M6 x 12 mm screws [3] or two 10-32 x 10 screws to attach each rear brace to the rack post and the adapter bracket.

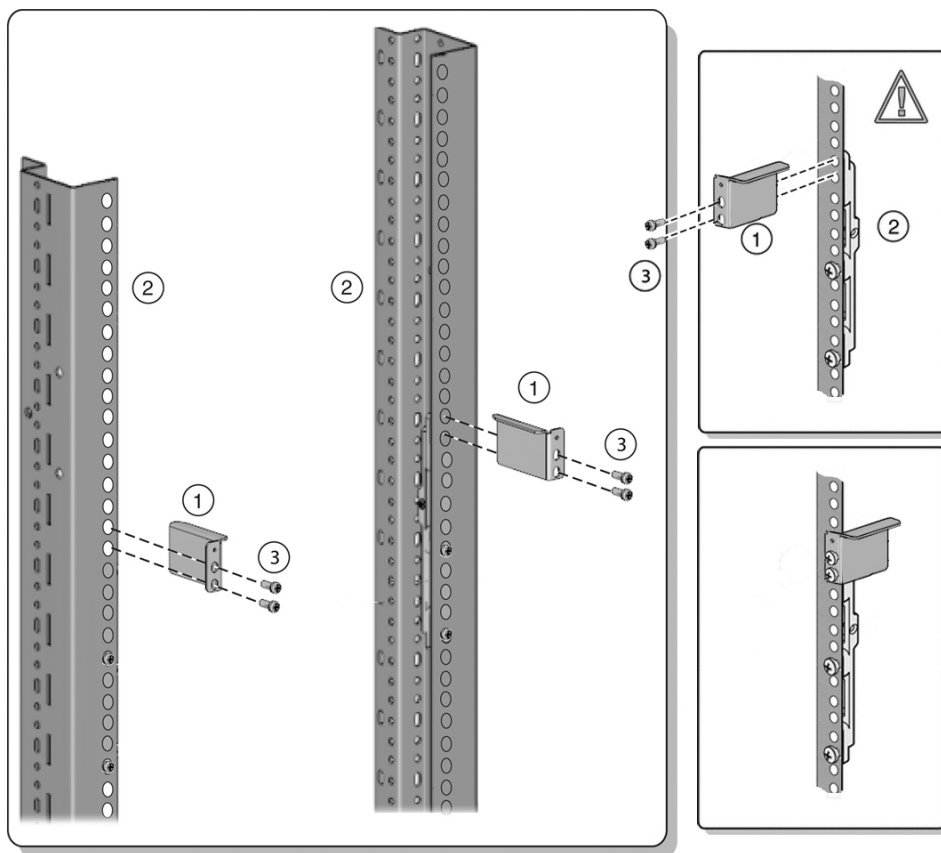

**Note** - Before tightening the screws, slide the brackets [1] up as far as they will go. The holes on the brackets are oval-shaped so they can move up and down when the screws are loose.

7. **Install the shelf rails into the rack.**



**Caution - System failure.** Orient the shelf rails properly, with the shelf facing inward and the gap toward the front of the rack; otherwise, the system might fall.

- a. Expand the shelf rails [1] to fit between the front and rear rack posts.

- b. **Insert the rear hooks of the shelf rails into the slots on the rear adapter brackets [2 and 3] first. Push down on the rail to engage the hooks.**

- c. Insert the front hooks of the shelf rails into the slots on the front adapter bracket. Push down on the rails to engage the hooks.

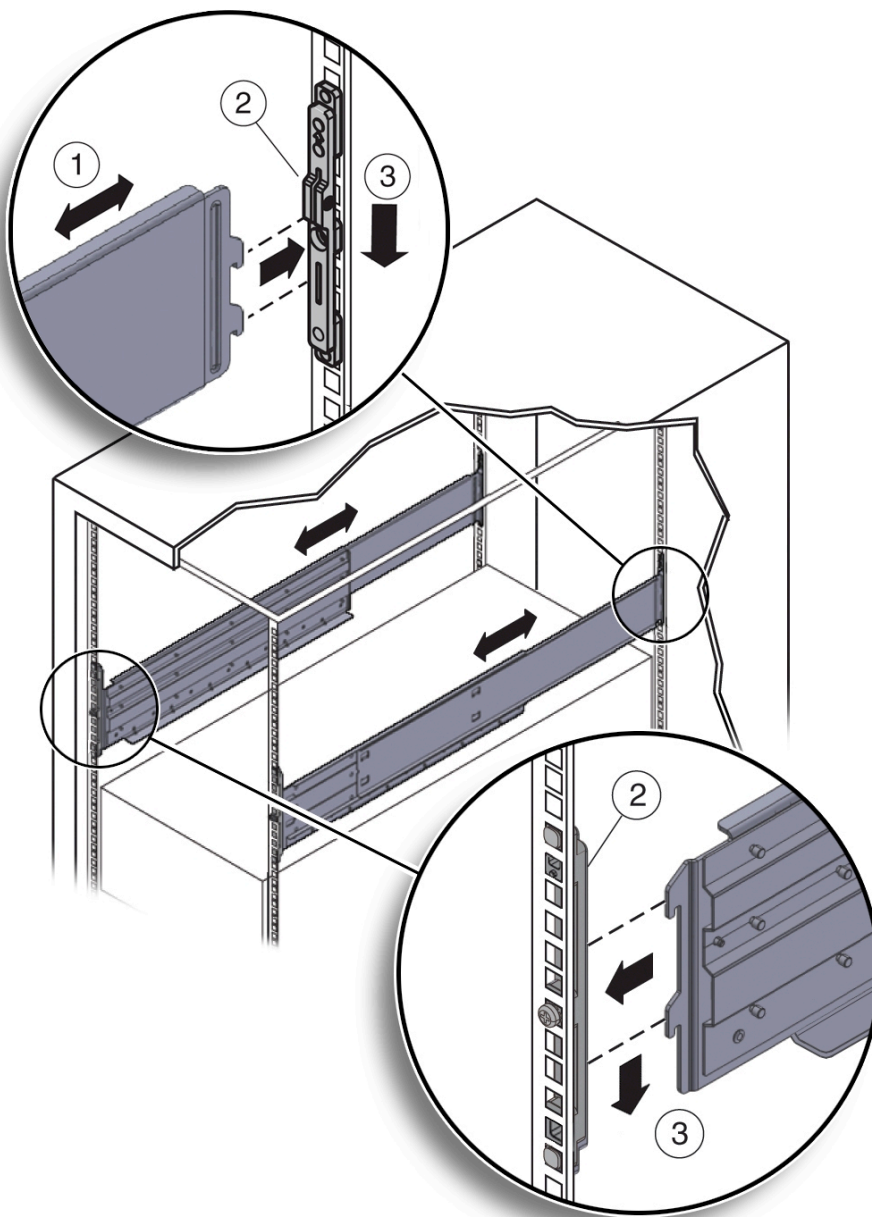

8. **Thread the four M4 x 10 flathead locking screws into the four adapter brackets [1]).**

These screws prevent the shelf rails from accidentally lifting out of the adapter brackets.

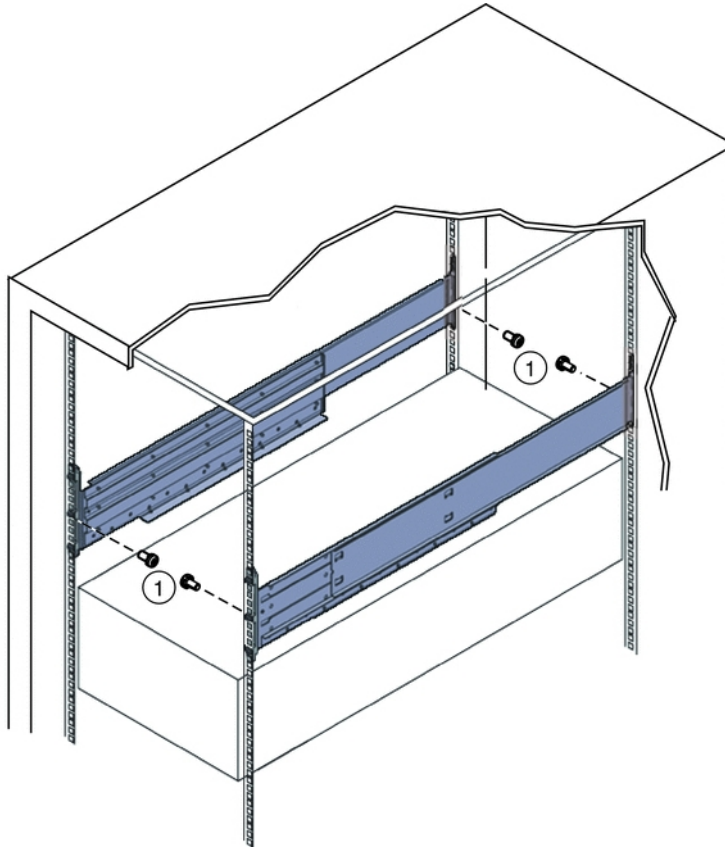

See Also [“Install the System Into a Rack” on page 122](#)

## ▼ Install the System Into a Rack

**Before You Begin** Before you begin installing your Oracle Database Appliance Version 1 into a rack, perform the steps in [“Install Rackmount Hardware Into a Rack” on page 115](#).

1. **Raise the system to slightly above the shelf surfaces.**  
Use a mechanical lift if possible.



---

**Caution - Personal injury or equipment damage.** Use a mechanical lift to install the system, or follow the precautions in [“Removing Components to Reduce System Weight” on page 114](#). Removing components reduces the weight from 160 pounds (72.6 kg) when fully loaded with components to approximately 96 pounds (43.5 kg).

---



---

**Caution - Tip hazard.** Always load equipment into a rack from the bottom up so that it does not become top-heavy and tip over. Deploy your rack’s anti-tilt bar to prevent the rack from tipping during installation.

---

2. **Slide the system onto the shelf rails until the rack-mounting ears contact the rack post. Adjust the top rear braces to fully insert the system.**



---

**Caution - Drop Hazard.** Do not release the system until it is *more* than 12 inches (305 mm) into the rack, and is firmly supported by the shelf rails. The shelf rails do not safely support the system until it is *more* than 12 inches (305 mm) inside the rack.

---

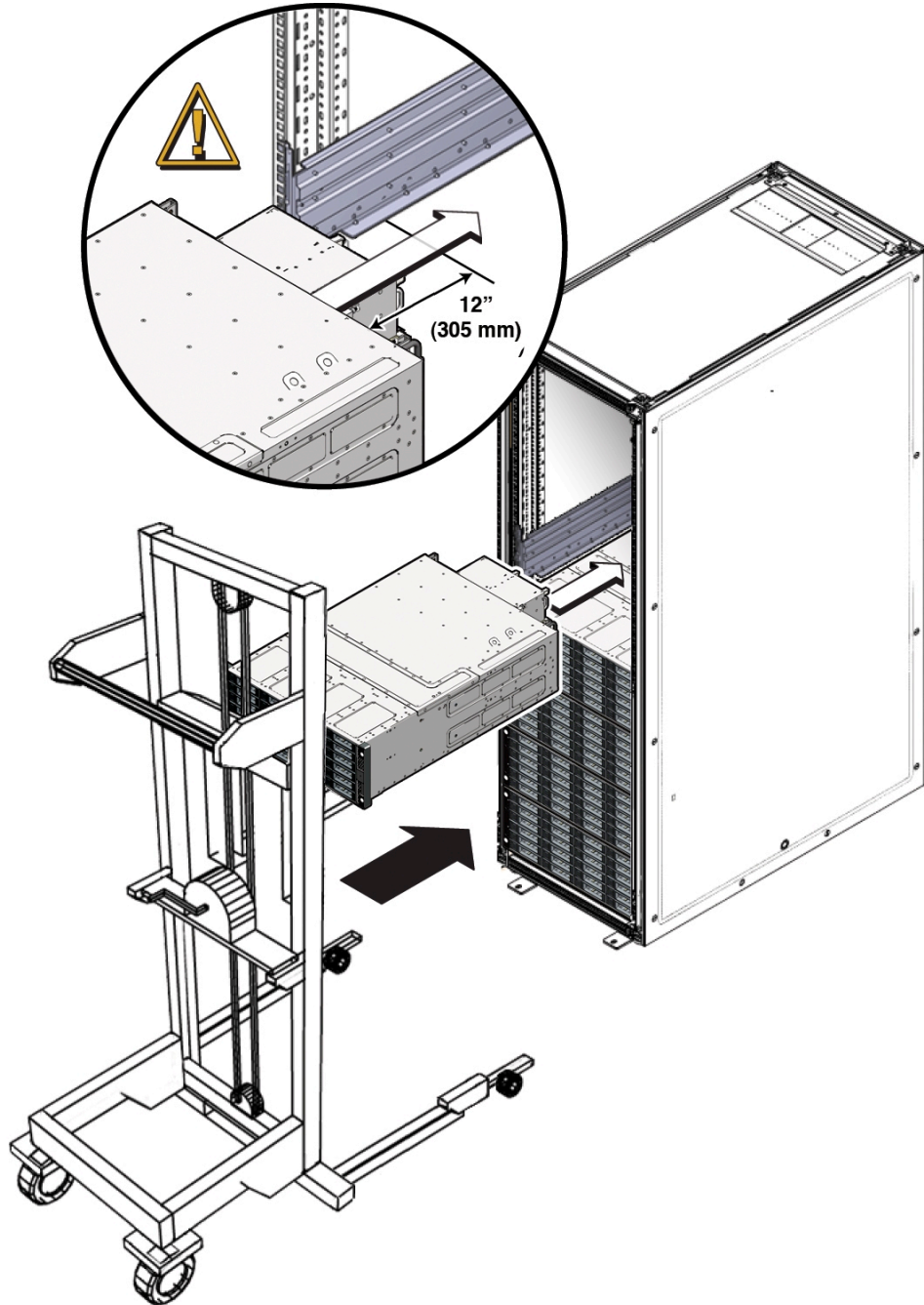



**3. Use four screws to attach the front of the system to the front of the rack.**

- On a threaded, round-hole rack, use four M6 x 12 mm screws or four 10-32 x 10 mm screws.
- On a square-hole rack, use four M6 x 16 mm screws.

---

**Note** - On square-hole racks, the screws pass through the rack and thread into the adapter bracket. On round-hole racks, the screws thread into the rack rails.

---

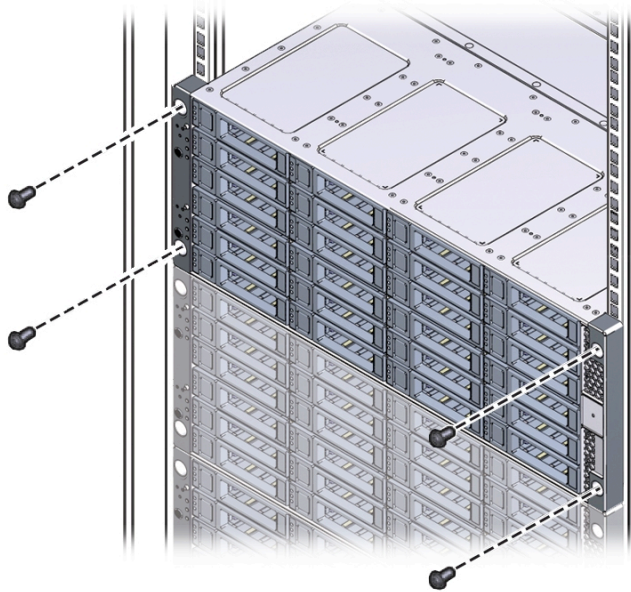

**4. To adjust the rear braces, do the following:**

- a. Loosen the screws on the rear braces [1].
- b. Slide the rear braces down until they rest firmly on top of the system [2].

- c. Tighten the screws in the rear braces [1].

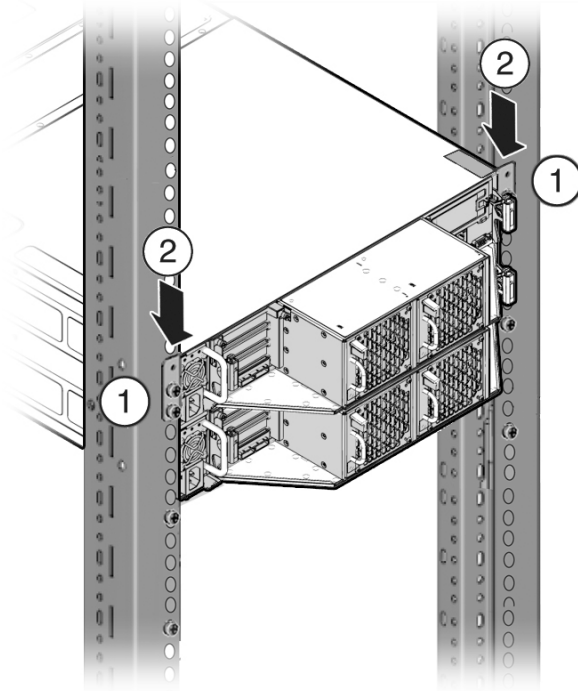

5. If you removed components from the system, replace them.

For instructions, see the *Service Manual*, which is part of the product documentation.

## Installing Shipping Brackets

This section includes the following information about installing the shipping brackets for Oracle Database Appliance Version 1:

- [“Transportation Kit Contents” on page 127.](#)
- If you plan to ship the system in a rack to another destination, see [“Install Shipping Brackets” on page 128.](#)

- If your system is shipped to you in a rack, you must remove the shipping brackets before placing the system into service. For instructions, see the *Oracle Database Appliance Service Manual*.

## Transportation Kit Contents

The following figure shows the hardware that is included in the Oracle Database Appliance Version 1 transportation kit.

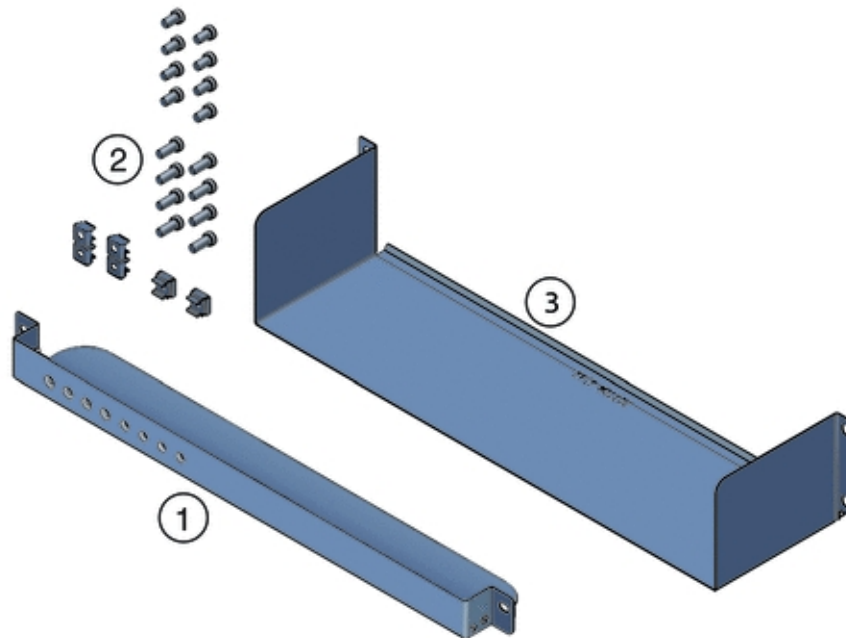

Callout	Description
1	Front shipping bracket.
2	Screws and cage nuts: For the rear shipping bracket: <ul style="list-style-type: none"> <li>■ Two sets of M6 x 30 and 10-32 x 1.25 inch screws, two screws per set.</li> <li>■ Two sets of M6 x 16 mm and 10-32 x 10 mm screws, four screws per set.</li> <li>■ Six M6 cage nuts. <b>NOTE</b> - The cage nuts are not used. Recycle unused hardware.</li> </ul>

Callout	Description
3	Rear shipping bracket.

## ▼ Install Shipping Brackets

If you plan to move or ship Oracle Database Appliance Version 1 in a rack to another location, you need to install the shipping brackets.

1. **Remove the two short screws that fasten the bottom of the system to the rack.**

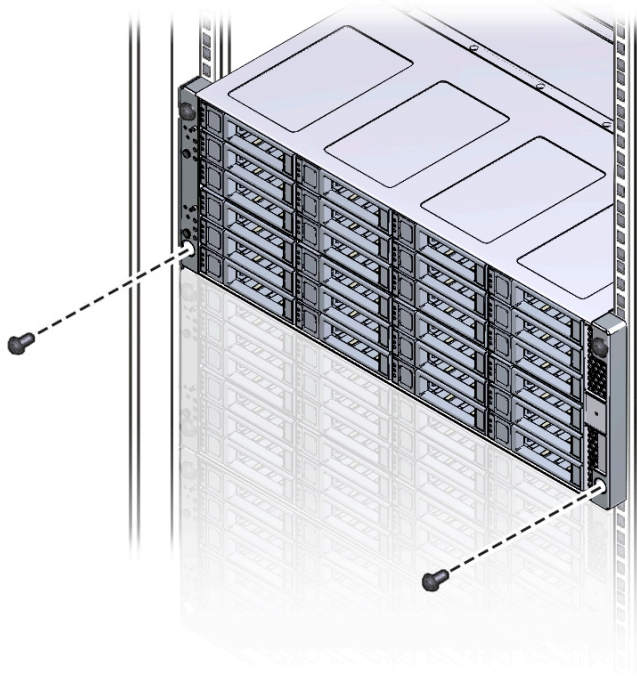

2. Insert the front shipping bracket [2] under the front of the system with the supporting flange underneath the system.

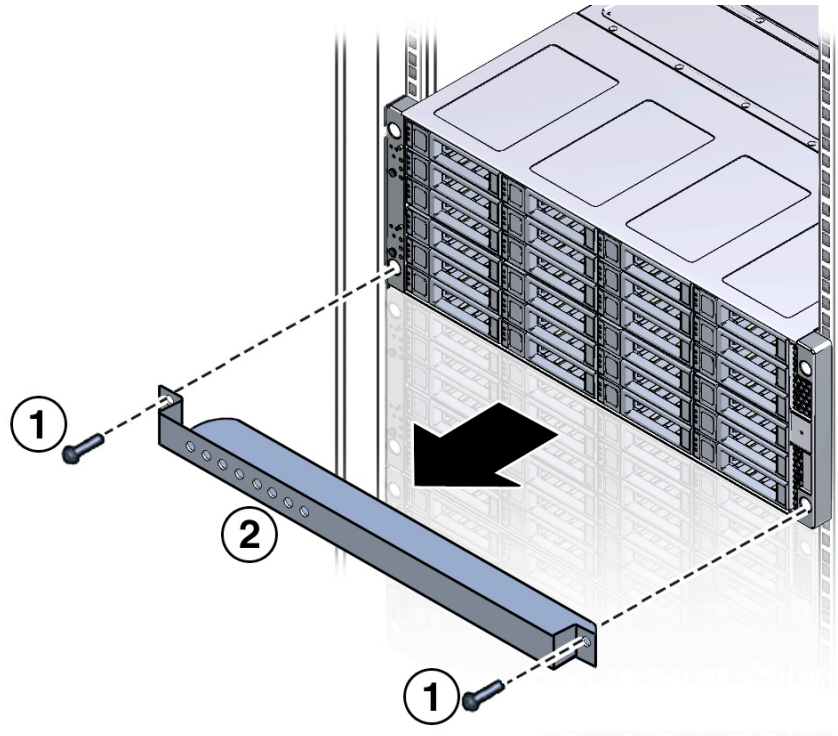

3. Use the two long screws (either the M6 x 30 mm screws or the 10-32 x 1.25 inch screws) [1] to fasten the shipping bracket [2] to the front of the system.  
Tighten the two long screws to secure the shipping bracket and the system to the rack.

---

**Note** - The front shipping bracket includes eight threaded holes used for storing unused screws. When the shipping brackets are not installed, the front shipping bracket holds the long screws used to install them. When the shipping brackets are installed, it stores the short screws that were used to secure the system to the front of the rack before the front shipping bracket was installed.

---

4. Insert the short screws into the four empty storage holes on the front shipping bracket.  
Store the screws so they can be used when the shipping bracket is removed.
5. Remove the bottom two screws that hold the rear adapter brackets in place.



**Caution - Equipment damage.** Do not remove the bottom screws unless you are certain that at least one upper screw is in place; otherwise, the system might fall.

**6. Insert the rear shipping bracket [2] under the back of the system with the side panels facing up.**

Use four screws [1] (either the M6 x 16 mm screws or the 10-32 x 10 mm screws) to fasten the rear shipping bracket to the rack. Do not finish tightening these screws. The screws should be tight enough to hold the bracket in place, but you should still be able to move the bracket slightly.

The bracket should be fastened to the posts, but loose enough to move slightly.

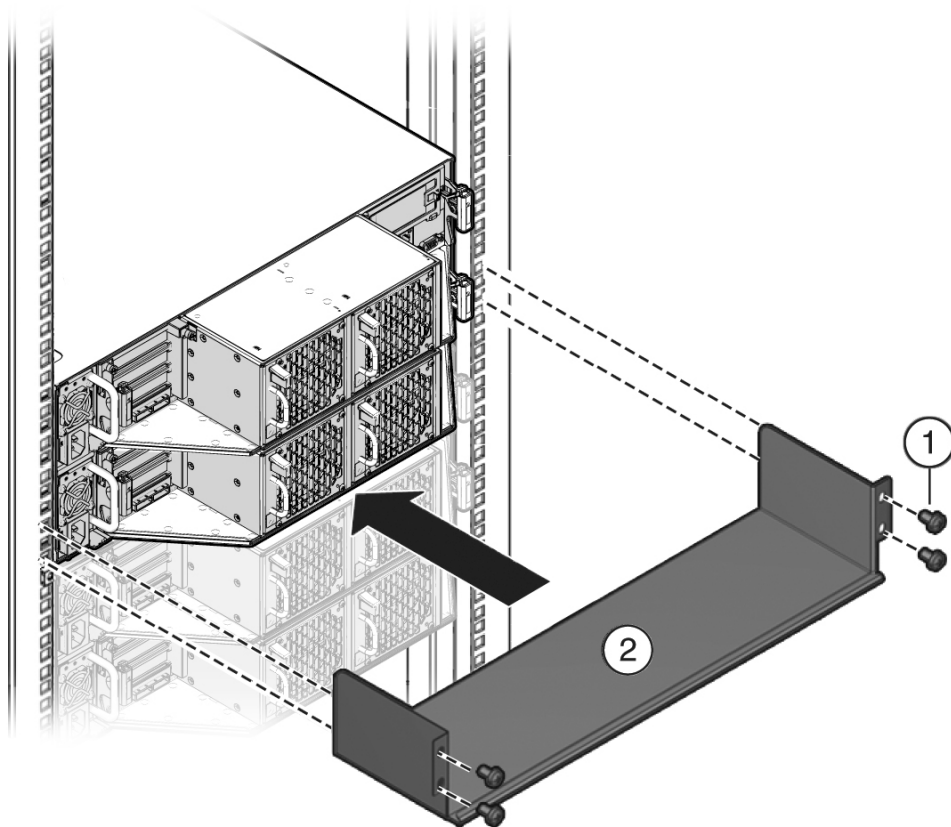

**7. Lift the rear shipping bracket up so that it rests firmly against the bottom of the system, then finish tightening the screws that hold the bracket in place.**

If necessary, loosen the screws enough so that you can move the bracket, then push the bracket against the bottom of the system and tighten the screws.



---

**Caution - Equipment damage.** To prevent damage to the system during shipping, the bottom shipping bracket must be positioned firmly against the bottom of the system.

---





# Index

---

## A

- acclimatization of hardware before installation, 71
- antistatic grounding strap, 77

## B

### back panel

#### features

- Oracle Database Appliance Version 1, 60
- Oracle Database Appliance X3-2/X4-2, 55
- Oracle Database Appliance X5-2, 48
- Oracle Database Appliance X6-2-HA, 41
- Oracle Database Appliance X6-2L, 36
- Oracle Database Appliance X6-2S/X6-2M, 34
- Oracle Database Appliance X7-2-HA, 30
- Oracle Database Appliance X7-2S/X7-2M, 23

#### storage shelf features

- Oracle Database Appliance X3-2/X4-2, 57
- Oracle Database Appliance X5-2, 50
- Oracle Database Appliance X6-2-HA, 43
- Oracle Database Appliance X7-2-HA, 31

#### view of

- Oracle Database Appliance Version 1, 60
- Oracle Database Appliance X3-2/X4-2, 54
- Oracle Database Appliance X5-2, 47
- Oracle Database Appliance X6-2-HA, 40
- Oracle Database Appliance X6-2L, 36
- Oracle Database Appliance X6-2S/X6-2M, 34
- Oracle Database Appliance X7-2-HA, 29
- Oracle Database Appliance X7-2S/X7-2M, 23

### boot drives

#### location

- Oracle Database Appliance Version 1, 60
- Oracle Database Appliance X3-2/X4-2, 52
- Oracle Database Appliance X5-2, 45
- Oracle Database Appliance X6-2-HA, 38

- Oracle Database Appliance X6-2L, 36
- Oracle Database Appliance X6-2S/X6-2M, 33
- Oracle Database Appliance X7-2-HA, 26
- Oracle Database Appliance X7-2S/X7-2M, 22

## C

### cluster

- supported connection, 11

### compatibility

#### appliance components

- Oracle Database Appliance X3-2/X4-2/X5-2, X6-2-HA and X7-2-HA, 85
- with rack systems, 77

### CPUs

- configurations supported, 11

## D

### DE2-24C

- storage shelf back panel, 50
- storage shelf front panel, 46

### DE2-24P

- storage shelf back panel, 57
- storage shelf front panel, 53

### DE3-24C

- storage shelf back panel, 31, 43
- storage shelf front panel, 27, 39

### disk drives

- storage, 11

## E

- electrical specifications, 63
- electrostatic discharge, precautions, 77
- environmental specifications, 65

Ethernet *See* network

## F

fans

supported, 11

front panel

features

- Oracle Database Appliance Version 1, 58
- Oracle Database Appliance X3-2/X4-2, 52
- Oracle Database Appliance X5-2, 45
- Oracle Database Appliance X6-2-HA, 38
- Oracle Database Appliance X6-2L, 35
- Oracle Database Appliance X6-2S/X6-2M, 33
- Oracle Database Appliance X7-2-HA, 26
- Oracle Database Appliance X7-2S/X7-2M, 22

storage shelf features

- Oracle Database Appliance X3-2/X4-2, 53
- Oracle Database Appliance X5-2, 46
- Oracle Database Appliance X6-2-HA, 39
- Oracle Database Appliance X7-2-HA, 27

view of

- Oracle Database Appliance Version 1, 58
- Oracle Database Appliance X3-2/X4-2, 51
- Oracle Database Appliance X5-2, 44
- Oracle Database Appliance X6-2-HA, 37
- Oracle Database Appliance X6-2L, 35
- Oracle Database Appliance X6-2S/X6-2M, 33
- Oracle Database Appliance X7-2-HA, 25
- Oracle Database Appliance X7-2S/X7-2M, 22

## H

hard disk drives *See* storage

## I

Infiniband adapter

replacing with Ethernet fiber adapter

Oracle Database Appliance X5-2, 74

installing *See* racking

## L

labels

applying for component identification

Oracle Database Appliance X3-2/X4-2/X5-2,  
X6-2-HA and X7-2-HA, 86

## M

management software

supported, 11

memory

installing optional components, 74  
supported, 11

## N

network

supported ports, 11

## O

options

installing optional components, 74

## P

PCIe

supported slots, 11

physical specifications, 61

power supplies

supported, 11

preparation *See* site preparation

processors *See* CPUs

## R

racking

applying labels to appliance components

Oracle Database Appliance X3-2/X4-2/X5-2,  
X6-2-HA and X7-2-HA, 86

compatibility, 77

confirming compatible components

Oracle Database Appliance X3-2/X4-2/X5-2,  
X6-2-HA and X7-2-HA, 85

inserting system into rack

Oracle Database Appliance Version 1, 111

Oracle Database Appliance X3-2/X4-2/X5-2,  
X6-2-HA and X7-2-HA, 83

- Oracle Database Appliance X6-2S/X6-2M/  
X6-2L and X7-2S/X7-2M, 81
  - installation sequence
    - Oracle Database Appliance X3-2/X4-2/X5-2,  
X6-2-HA and X7-2-HA, 84
  - installing rackmount hardware
    - Oracle Database Appliance Version 1, 115
    - Oracle Database Appliance X3-2/X4-2/X5-2,  
X6-2-HA and X7-2-HA, 110
    - Oracle Database Appliance X6-2S/X6-2M/  
X6-2L and X7-2S/X7-2M, 82
  - installing shipping brackets
    - Oracle Database Appliance Version 1, 126
    - Oracle Database Appliance X3-2/X4-2/X5-2,  
X6-2-HA and X7-2-HA, 110
    - Oracle Database Appliance X6-2S/X6-2M/  
X6-2L and X7-2S/X7-2M, 82
  - overview of, 73
  - precautions, 76
  - rackmount kit components
    - Oracle Database Appliance Version 1, 112
    - Oracle Database Appliance X3-2/X4-2/X5-2,  
X6-2-HA and X7-2-HA, 110
  - server nodes
    - Oracle Database Appliance X3-2/X4-2/X5-2,  
X6-2-HA and X7-2-HA, 110
    - Oracle Database Appliance X6-2S/X6-2M/  
X6-2L and X7-2S/X7-2M, 82
  - stabilizing the rack
    - Oracle Database Appliance X3-2/X4-2/X5-2,  
X6-2-HA and X7-2-HA, 86
    - Oracle Database Appliance X6-2S/X6-2M/  
X6-2L and X7-2S/X7-2M, 82
  - storage shelf
    - Oracle Database Appliance X3-2/X4-2/X5-2,  
X6-2-HA and X7-2-HA, 89
  - tools required
    - Oracle Database Appliance Version 1, 114
    - Oracle Database Appliance X3-2/X4-2/X5-2,  
X6-2-HA and X7-2-HA, 85
    - Oracle Database Appliance X6-2S/X6-2M/  
X6-2L and X7-2S/X7-2M, 82
  - using the rack anti-tilt bar
    - Oracle Database Appliance Version 1, 122
    - Oracle Database Appliance X3-2/X4-2/X5-2,  
X6-2-HA and X7-2-HA, 86
  - Oracle Database Appliance X6-2S/X6-2M/  
X6-2L and X7-2S/X7-2M, 82
- S**
- SAS
    - supported, 11
  - serial management (SerMgt) port, 11
  - serial number
    - location on system, 68
  - server node
    - back panel features
      - Oracle Database Appliance Version 1, 60
      - Oracle Database Appliance X3-2/X4-2, 55
      - Oracle Database Appliance X5-2, 48
      - Oracle Database Appliance X6-2-HA, 41
      - Oracle Database Appliance X6-2L, 36
      - Oracle Database Appliance X6-2S/X6-2M, 34
      - Oracle Database Appliance X7-2-HA, 30
      - Oracle Database Appliance X7-2S/X7-2M, 23
    - front panel features
      - Oracle Database Appliance X3-2/X4-2, 52
      - Oracle Database Appliance X5-2, 45
      - Oracle Database Appliance X6-2-HA, 38
      - Oracle Database Appliance X6-2L, 35
      - Oracle Database Appliance X6-2S/X6-2M, 33
      - Oracle Database Appliance X7-2-HA, 26
      - Oracle Database Appliance X7-2S/X7-2M, 22
    - how to rack
      - Oracle Database Appliance X3-2/X4-2/X5-2,  
X6-2-HA and X7-2-HA, 110
      - Oracle Database Appliance X6-2S/X6-2M/  
X6-2L and X7-2S/X7-2M, 82
    - supported, 11
    - view of back panel
      - Oracle Database Appliance X3-2/X4-2, 54
      - Oracle Database Appliance X5-2, 47
      - Oracle Database Appliance X6-2-HA, 40
      - Oracle Database Appliance X6-2L, 36
      - Oracle Database Appliance X6-2S/X6-2M, 34
      - Oracle Database Appliance X7-2-HA, 29
      - Oracle Database Appliance X7-2S/X7-2M, 23
    - view of front panel
      - Oracle Database Appliance Version 1, 58
      - Oracle Database Appliance X3-2/X4-2, 51
      - Oracle Database Appliance X5-2, 44

- Oracle Database Appliance X6-2-HA, 37
  - Oracle Database Appliance X6-2L, 35
  - Oracle Database Appliance X6-2S/X6-2M, 33
  - Oracle Database Appliance X7-2-HA, 25
  - Oracle Database Appliance X7-2S/X7-2M, 22
  - service processor (SP)
    - features, 11
  - shipping brackets
    - installing
      - Oracle Database Appliance Version 1, 126
      - Oracle Database Appliance X3-2/X4-2/X5-2, X6-2-HA and X7-2-HA, 110
      - Oracle Database Appliance X6-2S/X6-2M/X6-2L and X7-2S/X7-2M, 82
  - shipping components
    - accessory kit, 71
  - shipping contents
    - shipping pallet
      - Oracle Database Appliance X3-2/X4-2/X5-2, X6-2-HA and X7-2-HA, 84
      - Oracle Database Appliance X6-2S/X6-2M/X6-2L and X7-2S/X7-2M, 81
  - site preparation, 71
  - specifications
    - electrical, 63
    - environmental, 65
    - physical, 61
  - storage
    - installing optional components, 74
    - supported, 11
  - storage expansion shelf *See* DE2-24C storage shelf *See* DE2-24P storage shelf *See* DE3-24C storage shelf
  - storage shelf
    - back panel features
      - Oracle Database Appliance X3-2/X4-2, 57
      - Oracle Database Appliance X5-2, 50
      - Oracle Database Appliance X6-2-HA, 43
      - Oracle Database Appliance X7-2-HA, 31
    - front panel features
      - Oracle Database Appliance X3-2/X4-2, 53
      - Oracle Database Appliance X5-2, 46
      - Oracle Database Appliance X6-2-HA, 39
      - Oracle Database Appliance X7-2-HA, 27
    - how to rack
      - Oracle Database Appliance X3-2/X4-2/X5-2, X6-2-HA and X7-2-HA, 89
    - view of back panel
      - Oracle Database Appliance X3-2/X4-2, 54
      - Oracle Database Appliance X5-2, 47
      - Oracle Database Appliance X6-2-HA, 40
      - Oracle Database Appliance X7-2-HA, 29
    - view of front panel
      - Oracle Database Appliance X3-2/X4-2, 51
      - Oracle Database Appliance X5-2, 44
      - Oracle Database Appliance X6-2-HA, 37
      - Oracle Database Appliance X7-2-HA, 25
  - support
    - for product, 68
- T**
- technical support *See* support
  - TLI (Top Level Identifier)
    - label location
      - Oracle Database Appliance X3-2/X4-2/X5-2, X6-2-HA and X7-2-HA, 85
  - tools
    - required for racking
      - Oracle Database Appliance Version 1, 114
      - Oracle Database Appliance X3-2/X4-2/X5-2, X6-2-HA and X7-2-HA, 85
      - Oracle Database Appliance X6-2S/X6-2M/X6-2L and X7-2S/X7-2M, 82
- U**
- USB
    - supported slots, 11
- V**
- video
    - supported, 11