

Oracle® Database Appliance

Administration and Reference Guide



Release 12.2.1.3.0 for Linux x86-64

E93451-01

May 2018

The Oracle logo, consisting of a solid red square with the word "ORACLE" in white, uppercase, sans-serif font centered within it.

ORACLE®

Copyright © 2014, 2018, Oracle and/or its affiliates. All rights reserved.

This software and related documentation are provided under a license agreement containing restrictions on use and disclosure and are protected by intellectual property laws. Except as expressly permitted in your license agreement or allowed by law, you may not use, copy, reproduce, translate, broadcast, modify, license, transmit, distribute, exhibit, perform, publish, or display any part, in any form, or by any means. Reverse engineering, disassembly, or decompilation of this software, unless required by law for interoperability, is prohibited.

The information contained herein is subject to change without notice and is not warranted to be error-free. If you find any errors, please report them to us in writing.

If this is software or related documentation that is delivered to the U.S. Government or anyone licensing it on behalf of the U.S. Government, then the following notice is applicable:

U.S. GOVERNMENT END USERS: Oracle programs, including any operating system, integrated software, any programs installed on the hardware, and/or documentation, delivered to U.S. Government end users are "commercial computer software" pursuant to the applicable Federal Acquisition Regulation and agency-specific supplemental regulations. As such, use, duplication, disclosure, modification, and adaptation of the programs, including any operating system, integrated software, any programs installed on the hardware, and/or documentation, shall be subject to license terms and license restrictions applicable to the programs. No other rights are granted to the U.S. Government.

This software or hardware is developed for general use in a variety of information management applications. It is not developed or intended for use in any inherently dangerous applications, including applications that may create a risk of personal injury. If you use this software or hardware in dangerous applications, then you shall be responsible to take all appropriate fail-safe, backup, redundancy, and other measures to ensure its safe use. Oracle Corporation and its affiliates disclaim any liability for any damages caused by use of this software or hardware in dangerous applications.

Oracle and Java are registered trademarks of Oracle and/or its affiliates. Other names may be trademarks of their respective owners.

Intel and Intel Xeon are trademarks or registered trademarks of Intel Corporation. All SPARC trademarks are used under license and are trademarks or registered trademarks of SPARC International, Inc. AMD, Opteron, the AMD logo, and the AMD Opteron logo are trademarks or registered trademarks of Advanced Micro Devices. UNIX is a registered trademark of The Open Group.

This software or hardware and documentation may provide access to or information about content, products, and services from third parties. Oracle Corporation and its affiliates are not responsible for and expressly disclaim all warranties of any kind with respect to third-party content, products, and services unless otherwise set forth in an applicable agreement between you and Oracle. Oracle Corporation and its affiliates will not be responsible for any loss, costs, or damages incurred due to your access to or use of third-party content, products, or services, except as set forth in an applicable agreement between you and Oracle.

Contents

Preface

Audience	xv
Documentation Accessibility	xv
Conventions	xvi

1 Updating Oracle Database Appliance Software

1.1	About the Oracle Database Appliance Patch Bundle	1-1
1.2	About Installing the Latest Oracle Database Appliance Patch Bundle	1-3
1.3	Installing the Oracle Database Appliance Patch Bundle	1-5
1.3.1	Preparing to Install Oracle Database Appliance Patch Bundles	1-6
1.3.2	Step 1: Download the Oracle Database Appliance Patch Bundle from My Oracle Support	1-7
1.3.3	Step 2: Copy and Unpack the Patch Bundle	1-8
1.3.4	Step 3: Validate Readiness and Verify Components that Require Patching	1-9
1.3.5	Step 4: Patch the Server	1-11
1.3.6	Step 5: Patch the Shared Storage (Optional)	1-13
1.3.7	Step 6: Patch Oracle Database	1-13
1.3.8	Step 7: Validate the Patch Update	1-14
1.4	Performing a Bare Metal Restore	1-15
1.4.1	About Performing a Bare Metal Restore	1-15
1.4.2	Downloading an ISO Image for Bare Metal Restore	1-16
1.4.3	Re-imaging Oracle Database Appliance	1-16

2 Managing Oracle Database on Oracle Database Appliance

2.1	About the Oracle Database Appliance OAKCLI Utility	2-1
2.2	Oracle Database Features and Oracle Database Appliance	2-2
2.2.1	Oracle Database Appliance Plug-in for Oracle Enterprise Manager	2-3
2.2.2	Oracle EM Express and DB Console	2-3
2.2.3	Data Migration and Management and Oracle Database Appliance	2-3
2.2.4	Oracle Clusterware and Oracle Database Appliance	2-4

2.2.5	Oracle RAC One Node and Oracle Database Appliance	2-4
2.2.6	Oracle Real Application Clusters and Oracle Database Appliance	2-4
2.2.7	Administrative Groups and Users on Oracle Database Appliance	2-5
2.3	Creating and Converting Databases with OAKCLI	2-6
2.3.1	About Creating Databases with OAKCLI Commands	2-6
2.3.2	Creating, Using, and Removing Database Configuration Files with OAKCLI	2-7
2.3.3	Creating Snapshot Databases With OAKCLI	2-8
2.3.4	About Converting Single-Instance Databases to Oracle RAC or Oracle RAC One Node	2-9
2.4	About Managing Multiple Databases on Oracle Database Appliance	2-9
2.4.1	Downloading an End-User RDBMS Clone File	2-10
2.5	About Managing Multiple Database Instances Using Instance Caging	2-11
2.6	About Oracle Database Appliance SSDs	2-12
2.7	How to Upgrade and Update the Oracle Database on Oracle Database Appliance	2-14
2.7.1	About Oracle Database Upgrades and Updates on Oracle Database Appliance	2-14
2.7.2	Updating to Oracle Database 12.1.0.2.161018 from Previous Oracle Database 12.1.0.2.x Releases	2-15
2.7.3	Upgrading to Oracle Database 12.1.x from Oracle Database 11.2.0.4.x Releases	2-16
2.7.4	Upgrading to Oracle Database 11.2.0.4.161018 from Oracle Database 11.2.0.4.x Releases	2-18

3 Managing Storage

3.1	About Managing Storage	3-1
3.2	Preparing for a Storage Upgrade	3-2

4 Managing an Oracle Database Appliance Virtualized Platform

4.1	About Oracle Database Appliance Virtualized Platform	4-2
4.2	Oracle Database Appliance Virtualized Platform Architecture	4-3
4.2.1	About Oracle Database Appliance Virtualized Platform Architecture	4-3
4.2.2	About Virtual Machines and Oracle Database Appliance Virtualized Platforms	4-4
4.3	About Deploying an Oracle Database Appliance Virtualized Platform	4-7
4.4	How to Create and Manage Shared Repositories	4-9
4.4.1	Creating a Shared Repository	4-9
4.4.2	Showing the Status of Shared Repositories	4-10
4.4.3	Starting a Shared Repository	4-10
4.4.4	Stopping a Shared Repository	4-11

4.4.5	Deleting a Shared Repository	4-11
4.4.6	Increasing the Size of a Shared Repository	4-12
4.5	How to Manage Virtual Disks in Shared Repositories	4-12
4.5.1	Creating a Virtual Disk for Use in a Shared Repository	4-12
4.5.2	Viewing Information About Virtual Disks	4-13
4.5.3	Cloning Virtual Disks	4-13
4.5.4	Attaching a Virtual Disk to a Virtual Machine	4-14
4.5.5	Deleting a Virtual Disk	4-14
4.6	How to Manage Virtual Machine Templates	4-15
4.6.1	About Managing Virtual Machine Templates	4-15
4.6.2	Listing Virtual Machine Templates	4-16
4.6.3	Importing Virtual Machine Templates	4-17
4.6.4	Configuring a Virtual Machine Template	4-18
4.6.5	Showing Configured Values for a Virtual Machine Template	4-19
4.6.6	Modifying a Virtual Machine Template Configuration	4-19
4.6.7	Removing a Virtual Machine Template	4-20
4.7	How to Create Clones and Snap Clones of a Template	4-20
4.7.1	About Creating Clones and Snap Clones of a Template	4-20
4.7.2	Cloning a Template With OAKCLI	4-21
4.7.3	Creating a Snap Clone from a Template With OAKCLI	4-21
4.7.4	Creating a Snap Clone of an Existing Virtual Machine With OAKCLI	4-22
4.7.5	Creating a Snap Clone of an Existing Virtual Machine That Uses a Different Domain	4-22
4.8	How to Manage Virtual Machines on Oracle Database Appliance Virtualized Platform	4-23
4.8.1	About Managing Virtual Machines on Oracle Database Appliance Virtualized Platform	4-24
4.8.2	Listing the Virtual Machines in Your Repositories	4-25
4.8.3	Creating a Virtual Machine	4-26
4.8.4	Configuring a Virtual Machine	4-26
4.8.5	Starting and Stopping a Virtual Machine	4-28
4.8.6	Externally Configuring a Virtual Machine	4-28
4.8.7	Opening a Virtual Machine Console for a Virtual Machine	4-28
4.8.8	Creating an Image for a New Virtual Machine	4-29
4.8.9	Setting Up a Virtual Machine for Access from eth0 Using an IP Address	4-29
4.8.10	Adding or Removing a Virtual Disk to or from a Virtual Machine	4-29
4.8.11	Removing a Virtual Machine from a Shared Repository	4-30
4.8.12	Performing a Live Migration for an Oracle Database Appliance Virtual Machine	4-30
4.9	How to Create Driver Domain Virtual Machines	4-31
4.9.1	About Driver Domain Virtual Machines	4-31
4.9.2	Creating a Driver Domain Virtual Machine from a Template	4-32

4.9.3	Converting a Virtual Machine to a Driver Domain Virtual Machine	4-33
4.9.4	Converting a Root Disk to a Driver Domain Disk	4-34
4.10	How to Manage High Availability on Oracle Database Appliance Virtualized Platform	4-41
4.11	How to Manage CPU Pools on Oracle Database Appliance Virtualized Platform	4-42
4.11.1	About Managing CPU Pools for Resource Allocation	4-42
4.11.2	About Over-Subscribed CPU Pools	4-44
4.11.3	Creating a New CPU Pool on Oracle Database Appliance Virtualized Platform Nodes	4-44
4.11.4	Showing the CPU Pools Configured on Oracle Database Appliance Virtualized Platform Nodes	4-44
4.11.5	Changing the Number of CPUs Assigned to a CPU Pool on Oracle Database Appliance Virtualized Platform Nodes	4-45
4.11.6	Assigning a Virtual Machine to a CPU Pool on Oracle Database Appliance Virtualized Platform	4-45
4.12	About Network Infrastructure and Virtual Local Area Networks on Oracle Database Appliance Virtualized Platform	4-46
4.13	Managing Virtual Local Area Networks on User Domains and on ODA_BASE	4-49
4.14	How to Resize ODA_BASE	4-52
4.14.1	About Resizing ODA_BASE	4-52
4.14.2	Changing the ODA_BASE Core Count	4-52

5 Oracle Appliance Manager Command Line Interface

5.1	About the Oracle Appliance Manager Command-line Interface (OAKCLI)	5-3
5.2	Managing OAKCLI Privileges and Security with SUDO	5-4
5.3	oakcli add disk -local	5-6
5.4	oakcli apply	5-7
5.5	oakcli clone commands	5-8
5.5.1	oakcli clone vdisk	5-8
5.5.2	oakcli clone vm	5-9
5.6	oakcli configure commands	5-11
5.6.1	oakcli configure additionalnet	5-12
5.6.2	oakcli configure asr	5-12
5.6.3	oakcli configure cpupool	5-13
5.6.4	oakcli configure firstnet	5-14
5.6.5	oakcli configure ib2fiber	5-14
5.6.6	oakcli configure network	5-15
5.6.7	oakcli configure oda_base	5-15
5.6.8	oakcli configure repo	5-16
5.6.9	oakcli configure vm	5-17

5.6.10	oakcli configure vmtemplate	5-19
5.7	oakcli copy	5-21
5.8	oakcli create commands	5-21
5.8.1	oakcli create cpupool	5-22
5.8.2	oakcli create database	5-23
5.8.3	oakcli create dbhome	5-26
5.8.4	oakcli create dbstorage	5-27
5.8.5	oakcli create db_config_params	5-28
5.8.6	oakcli create repo	5-29
5.8.7	oakcli create snapshotdb	5-30
5.8.8	oakcli create vdisk	5-30
5.8.9	oakcli create vlan	5-31
5.9	oakcli delete commands	5-32
5.9.1	oakcli delete cpupool	5-33
5.9.2	oakcli delete database	5-33
5.9.3	oakcli delete db_config_params	5-33
5.9.4	oakcli delete dbhome	5-34
5.9.5	oakcli delete dbstorage	5-34
5.9.6	oakcli delete repo	5-35
5.9.7	oakcli delete vdisk	5-35
5.9.8	oakcli delete vlan	5-36
5.9.9	oakcli delete vm	5-36
5.9.10	oakcli delete vmtemplate	5-36
5.10	oakcli deploy	5-37
5.11	oakcli describe-cpucores	5-38
5.12	oakcli expand storage	5-39
5.13	oakcli diskwritecache	5-40
5.14	oakcli import vmtemplate	5-40
5.15	oakcli locate disk	5-42
5.16	oakcli manage diagcollect	5-42
5.17	oakcli migrate vm	5-43
5.18	oakcli modify commands	5-44
5.18.1	oakcli modify database	5-44
5.18.2	oakcli modify vm	5-45
5.18.3	oakcli modify vmtemplate	5-46
5.19	oakcli orachk	5-46
5.20	oakcli reconfigure osparams	5-47
5.21	oakcli resize dbstorage	5-49
5.22	oakcli restart oda_base	5-49
5.23	oakcli show commands	5-50
5.23.1	oakcli show asr	5-52

5.23.2	oakcli show cooling	5-53
5.23.3	oakcli show controller	5-53
5.23.4	oakcli show core_config_key	5-54
5.23.5	oakcli show cpupool	5-54
5.23.6	oakcli show databases	5-55
5.23.7	oakcli show db_config_params	5-55
5.23.8	oakcli show dbhomes	5-56
5.23.9	oakcli show dbstorage	5-56
5.23.10	oakcli show disk	5-57
5.23.11	oakcli show diskgroup	5-58
5.23.12	oakcli show enclosure	5-59
5.23.13	oakcli show env_hw	5-59
5.23.14	oakcli show expander	5-59
5.23.15	oakcli show ib	5-60
5.23.16	oakcli show fs	5-60
5.23.17	oakcli show iraid	5-60
5.23.18	oakcli show ismaster	5-60
5.23.19	oakcli show memory	5-61
5.23.20	oakcli show network	5-61
5.23.21	oakcli show power	5-61
5.23.22	oakcli show processor	5-62
5.23.23	oakcli show raidsyncstatus	5-62
5.23.24	oakcli show repo	5-63
5.23.25	oakcli show server	5-64
5.23.26	oakcli show storage	5-64
5.23.27	oakcli show validation storage	5-64
5.23.28	oakcli show validation storage errors	5-64
5.23.29	oakcli show validation storage failures	5-65
5.23.30	oakcli show vdisk	5-65
5.23.31	oakcli show version	5-66
5.23.32	oakcli show vlan	5-67
5.23.33	oakcli show vm	5-68
5.23.34	oakcli show vmconsole	5-69
5.23.35	oakcli show vmtemplate	5-70
5.24	oakcli start commands	5-70
5.24.1	oakcli start oda_base	5-71
5.24.2	oakcli start repo	5-71
5.24.3	oakcli start vm	5-71
5.25	oakcli stop command	5-72
5.26	oakcli stordiag	5-73
5.27	oakcli test asr	5-74

5.28	oakcli unpack	5-74
5.29	oakcli update	5-75
5.30	oakcli upgrade	5-76
5.31	oakcli validate	5-77

6 Validating and Troubleshooting Oracle Database Appliance

6.1	Oracle Database Appliance Diagnostics and Validation	6-1
6.1.1	Oracle Database Appliance Validation Command Overview	6-2
6.1.2	Examples of OAKCLI Validate Command Checks	6-3
6.2	Validate the Host Name	6-5
6.3	Oracle Database Appliance Configuration Error Messages	6-6
6.4	Preparing Log Files for Oracle Support Services	6-8
6.5	Additional Troubleshooting Tools and Commands	6-8
6.5.1	Oracle Appliance Manager Tools for Configuration Auditing and Disk Diagnosis	6-8
6.5.2	Trace File Analyzer Collector	6-9
6.6	Oracle Database Appliance Hardware Monitoring Tool	6-10

A Oracle Database Appliance Software Configuration Defaults

A.1	Directory Paths for Oracle Database Appliance	A-1
A.2	Oracle Groups and Users Configuration for Oracle Database Appliance	A-2
A.3	Database Disk Group Sizes for Oracle Database Appliance	A-2
A.4	Usable Storage on Oracle Database Appliance X5-2	A-4
A.5	Storage on Oracle Database Appliance	A-6
A.5.1	About Oracle Database Appliance Storage	A-6
A.5.2	Oracle ACFS Mount Points and Storage Space	A-7
A.5.3	Oracle ACFS Space Management	A-8
A.6	System Configuration for Oracle Database Appliance	A-9
A.7	Changing the Password	A-10

B Database Templates for Oracle Database Appliance

B.1	Types of Database Templates for Oracle Database Appliance	B-1
-----	-----------------------------------------------------------	-----

Index

List of Examples

4-1	Example of Showing the Status of All Shared Repositories	4-10
4-2	Example of Showing the Status of a Selected Shared Repository	4-10
4-3	Example of Starting a Shared Repository	4-11
4-4	Example of Stopping a Shared Repository	4-11
4-5	Example of Deleting a Shared Repository	4-11
4-6	Example of Increasing the Size of a Shared Repository	4-12
4-7	Example of Creating a Shared Virtual Disk	4-13
4-8	Example of Displaying the Information for All Vdisks	4-13
4-9	Example of Displaying Information for a Single Vdisk	4-13
4-10	Example of Cloning a Virtual Disk	4-14
4-11	Example of Attaching a Virtual Disk To a Virtual Machine	4-14
4-12	Example of Deleting a Virtual Disk from a Shared Repository	4-14
4-13	Example of Importing Virtual Machine Templates from an External Repository Assembly File	4-17
4-14	Example of Importing a Virtual Machine Template from Dom0	4-17
4-15	Example of Importing a Virtual Machine Template Using an External Repository URL	4-18
4-16	Example of Creating a Virtual Machine Clone from a Virtual Machine Template	4-21
4-17	Example of Creating a Snap Clone From a Virtual Machine Template	4-21
4-18	Example of Creating a Snap Clone From an Existing Virtual Machine	4-22
4-19	Example of Configuring a Virtual Machine	4-27
4-20	Example of Migrating a Virtual Machine from the Currently Running Node to Another Node	4-31
4-21	Example of Showing CPU Pools on a Node	4-43
4-22	Example of Creating a New CPU Pool on Oracle Database Appliance Virtualized Platform Nodes	4-44
4-23	Example of Showing CPUs Assigned to Defined CPU Pools on Oracle Database Appliance Virtualized Platform Nodes	4-44
4-24	Example of Changing the Number of CPUs Assigned to a CPU Pool on Oracle Database Appliance Virtualized Platform Nodes	4-45
4-25	Example of Assigning a Virtual Machine to a CPU Pool on Oracle Database Appliance Virtualized Platform	4-45
4-26	Example of Creating a Virtual Local Area Network	4-49
4-27	Example of Assigning and Removing a Virtual Local Area Network for a User Domain	4-50
4-28	Example of Assigning and Removing a Virtual Local Area Network for ODA_BASE	4-50
4-29	Example of Viewing Virtual Local Area Networks	4-51

4-30	Example of Deleting Virtual Local Area Networks	4-51
5-1	Reconfiguring Oracle Database Appliance with a New Core Count	5-7
5-2	Cloning a Virtual Disk	5-8
5-3	Creating a Virtual Machine Image	5-10
5-4	Creating a Virtual Machine Image in Driver Domain Mode	5-10
5-5	Configuring a VM Template	5-21
5-6	Preparing a Copy of the Configuration File	5-21
5-7	Deploying the Complete Oracle Database Appliance	5-37
5-8	Running the Configurator	5-38
5-9	Running the Offline Configurator with Advance Mode	5-38
5-10	Preloading an Existing Configuration File	5-38
5-11	Changing a User Group Name or ID	5-38
5-12	Viewing the Log File	5-38
5-13	Displaying the Current Core Configuration	5-39
5-14	Expanding Storage	5-39
5-15	Displaying the Write Cache Status of Disks	5-40
5-16	Importing a Virtual Machine Template from Dom0	5-41
5-17	Importing a Virtual Machine Template from a Remote Server	5-41
5-18	Importing Virtual Machine Templates from an Assembly on a Remote Server	5-41
5-19	Importing Virtual Machine Templates Into a Shared Repository From an Assembly on a Remote Server	5-41
5-20	Locating an Oracle ASM Disk by Turning on the Disk's LED	5-42
5-21	Modifying the Database Type	5-45
5-22	Modifying the Database Size	5-45
5-23	Sending a Message to a Running Virtual Machine	5-45
5-24	Modifying the Network Defined in a Virtual Machine Template	5-46
5-25	Viewing the Current and Suggested Kernel Parameters	5-48
5-26	Reconfiguring the Kernel Based on Available RAM	5-48
5-27	Increasing the Size of the DATA Volume	5-49
5-28	Displaying Information About the Local Disks	5-58
5-29	Displaying Information About the Shared Disks	5-58
5-30	Displaying Information About a Specific Shared Disk	5-58
5-31	Determining Which Node is the Master Node	5-61
5-32	Displaying Power Supply Information	5-61
5-33	Displaying the Available Virtual Machine Repositories	5-63
5-34	Displaying Details About a Specific Shared Repository	5-63
5-35	Determining if Storage Validation is Enabled	5-64

5-36	Displaying Information for All Virtual Disks	5-65
5-37	Displaying Information for a Single Virtual Disk	5-65
5-38	Displaying Details of Available Virtual Area Networks (VLANs)	5-67
5-39	Displaying Details for All Virtual Machines	5-68
5-40	Displaying Information for a Single Virtual Machine	5-68
5-41	Opening a Virtual Machine Console	5-69
5-42	Display Information About a Virtual Template	5-70
5-43	Starting ODA_BASE on the Local Node	5-71
5-44	Starting a Shared Repository on Node 0	5-71
5-45	Starting a Virtual Machine on Node 0	5-72
5-46	Forcing a Virtual Machine to Stop	5-72
5-47	Stopping a Shared Repository	5-73
5-48	Stopping the Local ODA_Base	5-73
5-49	Running Diagnostic Tests on a Disk in the Expansion Storage Shelf	5-73
5-50	Unpacking Packages into the Oracle Appliance Manager Repository	5-74
5-51	Verify the Contents of a Patch Bundle	5-76
A-1	Oracle ACFS Storage Space	A-8

List of Figures

4-1	Oracle Database Appliance Virtualized Platform Architecture	4-4
4-2	Architecture Overview of Oracle Database Appliance Virtualized Platform Shared Repositories	4-6
4-3	Basic Virtual Machine Local Area Network	4-48
4-4	Oracle Database Appliance Virtualized Platform with Virtual Local Area Networks	4-49

List of Tables

1-1	Patch Components and Purposes	1-2
1-2	Minimum Supported Appliance Manager Software Versions	1-3
2-1	Operating System Groups and Users on Oracle Database Appliance	2-5
4-1	Parameters Available for Configuring a Virtual Machine	4-27
4-2	Oracle Database Appliance Version 1 Virtualized Platform Network Interfaces	4-46
4-3	Oracle Database Appliance Virtualized Platform Dual Port 10-GbE Network Interfaces (Oracle Database Appliance X3-2 and later)	4-47
4-4	Oracle Database Appliance Virtualized Platform On Board Quad Port 10-GbE Network Interfaces (Oracle Database Appliance X3-2 and Later)	4-47
A-1	Directory Paths for Oracle Database Appliance	A-1
A-2	Oracle Groups and Users Configuration for Oracle Database Appliance	A-2
A-3	Approximate Database Disk Group Sizes for Oracle Database Appliance X5-2	A-3
A-4	Approximate Database Disk Group Sizes for Oracle Database Appliance Version 1, X3-2, and X4-2	A-3
A-5	Usable Storage on Oracle Database Appliance X5-2	A-5
A-6	Oracle ACFS Mount Points and Related Oracle ASM Disk Groups and Volume Information	A-7
A-7	System Configuration for Oracle Database Appliance	A-9
B-1	Oracle Database Appliance Database Generic Template Name Conversions	B-3
B-2	Oracle Database Appliance OLTP Database Template Sizes	B-3
B-3	Oracle Database Appliance DSS Database Template Sizes	B-4
B-4	Oracle Database Appliance In-Memory Database Template Size	B-5
B-5	Oracle Database Appliance X5-2 Database Template Size Storage Performance	B-5
B-6	Oracle Database Appliance X4-2 Database Template Size Storage Performance	B-6
B-7	Oracle Database Appliance X3-2 Database Template Size Storage Performance	B-6
B-8	Oracle Database Appliance Version 1 Database Template Size Storage Performance	B-7

Preface

Oracle Database Appliance is an optimized, prebuilt and ready-to-use clustered database system that is easy to deploy, operate, and manage. By integrating hardware and software, Oracle Database Appliance eliminates the complexities of nonintegrated, manually assembled solutions. Oracle Database Appliance reduces the installation and software deployment times from weeks or months to just a few hours while preventing configuration and setup errors that often result in suboptimal, hard-to-manage database environments.

- [Audience](#) (page xv)
- [Documentation Accessibility](#) (page xv)
- [Conventions](#) (page xvi)

Audience

This guide is intended for anyone who configures, maintains, or uses Oracle Database Appliance. This includes:

- System administrators
- Network administrators
- Database administrators
- Application administrators and users

This does not include information about Oracle Database architecture, tools, management, or application development that is covered in the main body of Oracle Documentation unless there are features specific to Oracle Database Appliance. Users of Oracle Database Appliance software are expected to have the same skills as users of any other Linux-based Oracle Database and Oracle Real Application Clusters installations.

Documentation Accessibility

For information about Oracle's commitment to accessibility, visit the Oracle Accessibility Program website at <http://www.oracle.com/pls/topic/lookup?ctx=acc&id=docacc>.

Access to Oracle Support

Oracle customers that have purchased support have access to electronic support through My Oracle Support. For information, visit <http://www.oracle.com/pls/topic/lookup?ctx=acc&id=info> or visit <http://www.oracle.com/pls/topic/lookup?ctx=acc&id=trs> if you are hearing impaired.

Conventions

The following text conventions are used in this document:

Convention	Meaning
boldface	Boldface type indicates graphical user interface elements.
<i>italic</i>	Italic type indicates book titles, emphasis, or placeholder variables for which you supply particular values. Italic type can also indicate a new term.
monospace	Monospace type inside a paragraph indicates an operating system command, or a filepath. In a separate line, it can indicate screen output, or a command example.
<i>monospace italic</i>	Monospace italic type indicates a variable in a command line. You provide the information for your system in place of that variable.
#	The pound (#) prompt indicates that you are logged in as the Superuser (root user) on a Linux operating system.

1

Updating Oracle Database Appliance Software

To keep Oracle Database Appliance running with the latest software, check for and apply the latest Oracle Database Appliance patch bundles when they are released.

Topics:

- [About the Oracle Database Appliance Patch Bundle](#) (page 1-1)
Oracle Database Appliance patching is done using the quarterly Oracle Database Appliance Patch Bundle.
- [About Installing the Latest Oracle Database Appliance Patch Bundle](#) (page 1-3)
Understand how to patch an existing Oracle Database Appliance to the latest version.
- [Installing the Oracle Database Appliance Patch Bundle](#) (page 1-5)
Review these topics to prepare for and install the Oracle Database Appliance Patch Bundle.
- [Performing a Bare Metal Restore](#) (page 1-15)
Reimage Oracle Database Appliance to perform a bare metal restore of Oracle Database Appliance.

1.1 About the Oracle Database Appliance Patch Bundle

Oracle Database Appliance patching is done using the quarterly Oracle Database Appliance Patch Bundle.

The Oracle Database Appliance Patch Bundle includes enhancements and fixes. The patch bundle provides all relevant patches for the entire system (bare metal or virtualized platform), including the following:

- BIOS
- Hardware drivers, Hardware Management Pack (HWM), and firmware drivers for various components
- Oracle Appliance Manager
- Oracle Linux
- Oracle VM
- Java Development Kit (JDK)
- Oracle Integrated Lights Out Manager (Oracle ILOM)
- Oracle Database Patch Set Update (PSU) and Oracle Database Bundle Patch (BP)
- Oracle Auto Service Request (Oracle ASR)
- Oracle Grid Infrastructure
 - Oracle Automatic Storage Management (Oracle ASM)

- Oracle Automatic Storage Management Cluster File System (Oracle ACFS)
- Oracle Trace File Analyzer
- Intelligent Platform Management Interface (IPMI)

The patch bundle consists of three logical groups of patches:

Table 1-1 Patch Components and Purposes

Patch Component	Objects Patched
SERVER (<i>server</i>)	<p>The SERVER component patch is mandatory.</p> <p>Updates the Oracle Linux operating system, Oracle ILOM, BIOS, Hardware Management Pack, IPMI, OAK, Oracle ASR, and local disks.</p> <p>For virtualized environment, the patch includes the Dom0 updates.</p> <p>The Server patch also includes Oracle Grid Infrastructure (GI) stack, including Oracle ASM, Oracle ACFS , and Oracle Trace File Analyzer.</p>
STORAGE (<i>storage</i>)	<p>The STORAGE component patch is recommended.</p> <p>Updates the shared storage disk firmware and Controller Firmware for HDD, SSD, Controller, and Expander.</p>
DB (<i>database</i>)	<p>The DATABASE component patch is optional.</p> <p>Updates the Oracle Database RDBMS stack.</p>

 **Note:**

You must apply patch bundle components in this order:

1. SERVER (*server*)
2. STORAGE (*storage*)
3. DB (*database*)

Oracle Database Appliance Patch Bundle Guidelines

You can carry out rolling upgrades with both the *server* and *DB* patches.

You must patch the *server* component before patching the *storage* and *DB* components. You can defer patching the *DB* component. You must schedule downtime and restart the system for the *storage* patch. However, you can usually defer running the *storage* patch until a scheduled maintenance window. Patching the *DB* component does not require system downtime.

 **Caution:**

Apply the *server* patch before you apply the *storage* patch. Apply the *server* patch to each node before you apply any other patches. You must restart each server node after it is patched. The *server* patch restarts a server node. The *storage* patch restarts both nodes.

If you have Oracle Database running using High Availability options such as Oracle Real Application Clusters (RAC), then there is no downtime required while the patches are being installed. Oracle Appliance Manager verifies that the host meets all prerequisites to prevent you from installing patches in the wrong order. For example, you cannot install the `database` patch before you install the `server` patch. When applied, the output displayed by the patch process advises you if the patch is being installed on one or both nodes. For older patches that only install on a single node, you must run the command `oakcli update -patch` on the second node.

Supported and Recommended Appliance Manager Software Versions

The *Oracle Database Appliance Release Notes* include information about the latest Oracle Database Appliance patch bundle and the supported versions for the components. Oracle recommends updating the appliance with the latest Oracle Database Appliance software version to take advantage of new features, fixes, and the latest supported component versions.

Table 1-2 Minimum Supported Appliance Manager Software Versions

Oracle Database Appliance Hardware Model	Minimum Supported Software Version
X5-2	12.1.2.5.0
X4-2	12.1.2.5.0
X3-2	12.1.2.5.0
V1	12.1.2.5.0

1.2 About Installing the Latest Oracle Database Appliance Patch Bundle

Understand how to patch an existing Oracle Database Appliance to the latest version.

Oracle Database Appliance Patch Bundle releases include software and firmware updates for Oracle Database Appliance.

▲ Caution:

If you have Oracle Database 11.2 or 12.1 that is using Oracle Automatic Storage Management (Oracle ASM) and you want to upgrade to a higher release of Oracle Database, then you must be on at least Oracle Database Appliance 12.1.2.12.0 and Database Home 12.1.0.2.170814. Known issues with Oracle Automatic Storage Management (Oracle ASM) on earlier versions are preventing the REDO diskgroup from mounting for databases.

The upgrade path for Oracle Database 11.2 or 12.1 Oracle ASM is as follows:

- If you are on Oracle Database Appliance version 12.1.2.6.0 or later, then upgrade to 12.1.2.12 or higher before upgrading your database.
- If you are on Oracle Database Appliance version 12.1.2.5 or earlier, then upgrade to 12.1.2.6.0, and then upgrade again to 12.1.2.12 or higher before upgrading your database.

For all database versions and storage, if you are using Oracle Database Appliance version 12.1.2.5.0 or earlier, you must upgrade to 12.1.2.6.0 before upgrading to a higher version of Oracle Database Appliance. Changes introduced in the earlier release re-group the components and control the rolling of Oracle Database Appliance patching from one node to another.

About Oracle Database Appliance Software Updates

To keep Oracle Database Appliance running with the latest software, check for and apply Oracle Database Appliance Patch Bundles when they are released. As well as offering new features, patches may improve the functionality of existing features.

Oracle Database Appliance Patch Bundles are released on a quarterly schedule. The *Oracle Database Appliance Release Notes* include information about the latest Oracle Database Appliance patch bundle and a list of component versions in the patch bundle. Oracle recommends updating the appliance with the latest Oracle Database Appliance software version to take advantage of new features, fixes, and the latest supported component versions. See the *Oracle Database Appliance Release Notes* for the upgrade paths.

▲ Caution:

Do not patch Oracle Database Appliance using individual patches for Oracle Grid Infrastructure, Oracle Database, or Oracle Linux. Also do not use individual infrastructure patches, such as firmware patches. You must only use Oracle Database Appliance patches.

If you use patches that are not intended for Oracle Database Appliance, or if you use Opatch, or a similar patching tool, then Oracle Database Appliance inventory is not updated, and you cannot complete future patch updates.

Overview of the Patch Upgrade

Before patching Oracle Database Appliance, verify that a database is successfully deployed on Oracle Database Appliance. Run the `oakcli orachk` command to confirm that the initial deployment completed successfully.

The patch bundle upgrade consists of the following steps:

1. Download the Oracle Database Appliance Patch Bundle from My Oracle Support.
2. Copy and unpack the patch bundle.
3. Verify components that require patching.
4. Patch the server.
5. (Optional) Patch the shared storage.
6. Patch Oracle Database.
7. Validate the patch update.

Related Topics

- [oakcli orachk](#) (page 5-46)
Use the `oakcli orachk` command to audit configuration settings with the ORAchk utility.

1.3 Installing the Oracle Database Appliance Patch Bundle

Review these topics to prepare for and install the Oracle Database Appliance Patch Bundle.

Topics:

- [Preparing to Install Oracle Database Appliance Patch Bundles](#) (page 1-6)
Decide how you want to patch Oracle Database Appliance.
- [Step 1: Download the Oracle Database Appliance Patch Bundle from My Oracle Support](#) (page 1-7)
Use this procedure to download the Oracle Database Appliance Patch Bundle.
- [Step 2: Copy and Unpack the Patch Bundle](#) (page 1-8)
Copy the patch to your server, and use `oakcli unpack -package` to unpack the patch bundle.
- [Step 3: Validate Readiness and Verify Components that Require Patching](#) (page 1-9)
Use command-line interface commands to check for any problems before you start the patch upgrade and to verify the components that require patching.
- [Step 4: Patch the Server](#) (page 1-11)
Use Oracle Appliance Manager (`oakcli update -patch`) to patch the server. You can use automatic (rolling) or manual patching.
- [Step 5: Patch the Shared Storage \(Optional\)](#) (page 1-13)
Use this procedure to patch the shared storage now, or during a maintenance window.
- [Step 6: Patch Oracle Database](#) (page 1-13)
Apply the Oracle Database Appliance Patch Bundle to update Oracle Database on Node 0 and Node 1.

- [Step 7: Validate the Patch Update](#) (page 1-14)
Run the command `oakcli show version -detail` to verify that all components of the Oracle Database Appliance patch installation are updated.

1.3.1 Preparing to Install Oracle Database Appliance Patch Bundles

Decide how you want to patch Oracle Database Appliance.

You can patch Oracle Database Appliance using either automatic rolling patching, or manual rolling patching. Review the steps for each procedure, and decide which option you want to use. For each option, the steps are the same, except for the server patch.

For both options, the storage patch requires a system restart of Oracle Database Appliance after completing the storage patch update. However, you can defer the update to a maintenance window.

Automatic Rolling Patching Option

The advantage of automatic rolling patching is that it is simple to do, in that you start the patch, and the patch process completes automatically. However, services and clients may experience delays during node restarts.

Automatic rolling patching consists of the following steps:

1. Download the Oracle Database Appliance Patch Bundle from My Oracle Support.
2. Copy and unpack the patch bundle to both Oracle Database Appliance nodes.
3. Verify the components that require patching.
4. From Node 0, start the patch. The automatic patch option performs the server patch update on Node 1, and restarts Node 1. It then patches the server on Node 0, and restarts Node 0.
5. (optional) Patch the shared storage components. This patch requires a system restart, but you can usually defer the restart.
6. Patch Oracle Databases. No restart is required.
7. Validate the Oracle Database and Oracle Grid Infrastructure patch installation.

Manual Rolling Patching Option

The advantage of manual rolling patching is that you can first migrate the services and clients from one node to another before the node restarts, and then manually patch the second node. This migration can be more graceful than a failover, so it can minimize interruptions to ongoing transactions.

Manual rolling patching consists of the following steps:

1. Download the Oracle Database Appliance Patch Bundle from My Oracle Support.
2. Copy and unpack the patch bundle to both Oracle Database Appliance nodes.
3. Verify the components that require patching.
4. Complete the patch manually in a two-step process.
 - a. Log in to Node 0, and patch the server on Node 0 by running the `oakcli patch` command using the `--local` option.
 - b. Wait until the patch operation completes, and Node 0 is available.

- c. Log in to Node 1, and patch the server on Node 1 by running the `oakcli patch` command using the `--local` option.
5. (optional) Patch the shared storage. This patch requires a system restart, but you can usually defer the restart.
6. Patch Oracle Databases. No restart is required.
7. Validate the Oracle Database and Oracle Grid Infrastructure patch installation.

1.3.2 Step 1: Download the Oracle Database Appliance Patch Bundle from My Oracle Support

Use this procedure to download the Oracle Database Appliance Patch Bundle.

Caution:

If you have Oracle Database 11.2 or 12.1 that is using Oracle Automatic Storage Management (Oracle ASM) and you want to upgrade to a higher release of Oracle Database, then you must be on at least Oracle Database Appliance 12.1.2.12.0 and Database Home 12.1.0.2.170814. Known issues with Oracle Automatic Storage Management (Oracle ASM) on earlier versions are preventing the REDO diskgroup from mounting for databases.

The upgrade path for Oracle Database 11.2 or 12.1 Oracle ASM is as follows:

- If you are on Oracle Database Appliance version 12.1.2.6.0 or later, then upgrade to 12.1.2.12 or higher before upgrading your database.
- If you are on Oracle Database Appliance version 12.1.2.5 or earlier, then upgrade to 12.1.2.6.0, and then upgrade again to 12.1.2.12 or higher before upgrading your database.

For all database versions and storage, if you are using Oracle Database Appliance version 12.1.2.5.0 or earlier, you must upgrade to 12.1.2.6.0 before upgrading to a higher version of Oracle Database Appliance. Changes introduced in the earlier release re-group the components and control the rolling of Oracle Database Appliance patching from one node to another.

1. From an external client machine, log into My Oracle Support and locate patch 27648022 for the Oracle Database Appliance Patch Bundle for 12.2.1.3.0.
<https://support.oracle.com/>
2. Review the *Oracle Database Appliance Release Notes* for the available patches and for known issues.
3. Click **Download** for all files to obtain the complete Oracle Database Appliance Patch Bundle.

Either download it directly, or download it to a thumb drive, and copy the file to the server nodes using the thumb drive.

 **Caution:**

Only use either an Oracle Database Appliance Patch Bundle, or if you are an SAP customer, an SAP patch bundle downloaded from the SAP Service Marketplace. Do not patch Oracle Database Appliance using individual patches for Oracle Grid Infrastructure, Oracle Database, or Oracle Linux. Also do not use individual infrastructure patches, such as firmware patches. You must only use Oracle Database Appliance patches.

If you use patches that are not intended for Oracle Database Appliance, or if you use Opatch, or a similar patching tool, then Oracle Database Appliance inventory is not updated, and you cannot complete future patch updates.

1.3.3 Step 2: Copy and Unpack the Patch Bundle

Copy the patch to your server, and use `oakcli unpack -package` to unpack the patch bundle.

On Oracle Database Appliance systems, all patching commands are executed as `root` user.

After you copy the patch to the required location, run the command `oakcli unpack -package`. This command extracts (unzips) the patch bundle, and copies the patch bundle contents into the patch repository. Use the following syntax to specify the complete path to the patch bundle file, where `path` is the absolute path to the patch file:

```
# oakcli unpack -package absolute_package_name
```

 **Note:**

Before patching Oracle Database Appliance, verify that a database is successfully deployed on Oracle Database Appliance. Run the command `oakcli orachk` to confirm that the initial deployment completed successfully.

1. Log in as `root`.
2. Copy the patch files into a temporary directory (such as `/tmp`) on Oracle Database Appliance.
3. Unpack the patch bundle by executing the command `oakcli unpack -package patch bundle name`.

This command unzips and extracts the patch bundle and copies the contents into the patch repository. While unpacking, specify the complete path to the patch bundle file.

```
# oakcli unpack -package /tmp/p27119652_122130_Linux-x86-64_1of3.zip
# oakcli unpack -package /tmp/p27119652_122130_Linux-x86-64_2of3.zip
# oakcli unpack -package /tmp/p27119652_122130_Linux-x86-64_3of3.zip
```

1.3.4 Step 3: Validate Readiness and Verify Components that Require Patching

Use command-line interface commands to check for any problems before you start the patch upgrade and to verify the components that require patching.

Before installing the patch, run commands to verify that Oracle Database Appliance is ready to patch.

Use the `oakcli validate` command on Node 0 to identify any possible problems in your environment, such as missing dependencies or other conflicts that can cause issues with patch installation. Conflicts can be introduced if you customize the standard configuration. Several validation parameters are available.

To review the components that require patching, run the `oakcli update -patch release --verify` command. The output lists the components that require patching. If a component is listed as `Up-to-date` for the supported version that you indicate with the `-ver` flag, then that component does not require patching.

1. Run the `oakcli orachk` command to confirm that the initial deployment completed successfully.
2. Verify that a database is successfully deployed on Oracle Database Appliance.
3. Validate system readiness for patching.

Run the `oakcli validate` command on both nodes using the following syntax to validate your system.

```
# oakcli validate -c ospatch -ver 12.2.1.3.0
```

The output informs you if the patch can be installed on your environment. If the output from the command indicates that there is a problem (for example, if there are missing RPM dependencies on the server), then address the issue, and run `oakcli validate` again.



Note:

These commands run only on the local node. Run the commands on both nodes to check both Oracle Database Appliance nodes.

4. (Optional) Run the `oakcli update -patch release --verify` command on Node 0 and Node 1 to view the proposed changes included in the patch.

When the Supported Version of a component is `Up-to-date` on the report, the existing version on the system is current and that component is not patched. For example, the patch upgrades the OAK component from Installed Version 12.1.2.9.0 to Proposed Version 12.1.2.10.0. For Component OL, the Installed Version is 6.8 and is `Up-to-date`.

```
# oakcli update -patch 12.1.2.10 --verify
```

```
INFO: 2017-02-13 14:20:37: Reading the metadata file now...
```

Patch Version	Component Name	Installed Version	Proposed
-----	-----	-----	-----
	Controller_INT	4.230.40-3739	Up-to-date
	Controller_EXT	09.00.00.00	10.00.00.00

Expander	0291	Up-to-date
SSD_SHARED {		
[c2d20,c2d21,c2d22,c2d23]	A29A	Up-to-date
[c2d0,c2d1,c2d2,c2d3,c2d4,		
c2d5,c2d6,c2d3,c2d4,c2d5,		
c2d6,c2d7,c2d8,c2d9,c2d10,		
c2d11,c2d12,c2d13,c2d14,		
c2d15,c2d16,c2d17,c2d18,		
c2d19]	A29A	Up-to-date
}		
SSD_LOCAL	0R3Q	Up-to-date
ILOM	3.2.7.26.a r112632	3.2.8.24 r114611
BIOS	38050100	38070000
IPMI	1.8.12.4	Up-to-date
HMP	2.3.5.2.5	2.3.5.2.8
OAK	12.1.2.9.0	12.1.2.10.0
OL	6.8	Up-to-date
GI_HOME	12.1.0.2.161018(2400	12.1.0.2.170117(2473
	6101,23854735)	2082,24828633)
DB_HOME	12.1.0.2.160719(2305	12.1.0.2.170117(2473
	4246,23054327)	2082,24828633)
ASR	5.5.1	Up-to-date

Related Topics

- [oakcli orachk](#) (page 5-46)
Use the `oakcli orachk` command to audit configuration settings with the ORAchk utility.
- [oakcli validate](#) (page 5-77)
Validates the state of an Oracle Database Appliance or the viability of an operating system patch.
- [oakcli update](#) (page 5-75)
Use the `oakcli update` command to apply Oracle Database Appliance patches.

1.3.5 Step 4: Patch the Server

Use Oracle Appliance Manager (`oakcli update -patch`) to patch the server. You can use automatic (rolling) or manual patching.

Caution:

If you have Oracle Database 11.2 or 12.1 that is using Oracle Automatic Storage Management (Oracle ASM) and you want to upgrade to a higher release of Oracle Database, then you must be on at least Oracle Database Appliance 12.1.2.12.0 and Database Home 12.1.0.2.170814. Known issues with Oracle Automatic Storage Management (Oracle ASM) on earlier versions are preventing the REDO diskgroup from mounting for databases.

The upgrade path for Oracle Database 11.2 or 12.1 Oracle ASM is as follows:

- If you are on Oracle Database Appliance version 12.1.2.6.0 or later, then upgrade to 12.1.2.12 or higher before upgrading your database.
- If you are on Oracle Database Appliance version 12.1.2.5 or earlier, then upgrade to 12.1.2.6.0, and then upgrade again to 12.1.2.12 or higher before upgrading your database.

For all database versions and storage, if you are using Oracle Database Appliance version 12.1.2.5.0 or earlier, you must upgrade to 12.1.2.6.0 before upgrading to a higher version of Oracle Database Appliance. Changes introduced in the earlier release re-group the components and control the rolling of Oracle Database Appliance patching from one node to another.

Before patching, download the Oracle Database Appliance Patch Bundle from My Oracle Support, copy the patch to both nodes and unpack the bundles. Oracle recommends running commands to validate readiness for patching.

Note:

Before patching Oracle Database Appliance, verify that a database is successfully deployed on Oracle Database Appliance. Run the `oakcli orachk` command to confirm that the initial deployment completed successfully.

Automatic Server Patch Procedure

The automatic server patching process is a rolling upgrade that automatically patches Node 0 after patching Node 1. This automatic procedure enables Oracle Grid Infrastructure to continue to be up and running on one of the nodes during patching.

1. Download the Oracle Database Appliance server patch bundle from My Oracle Support to Node 0.
2. Log in to Node 0 as the root user.

3. Run the command `oakcli update -patch version --server`, where *version* is the Patch Bundle version. Either patch automatically or locally.

```
#!/opt/oracle/oak/bin/oakcli update -patch 12.2.1.3.0 --server
```

This command patches the server on Node 1. After that patch update is complete, it then automatically patches Node 0

4. Observe the patch status reports.

As the patch runs, it displays output that advises you of the installation progress. Part of the server patch update requires node 1 to be restarted, then node 0 to be restarted. Wait until Node 0 shuts down and completes restarting before proceeding to the next step.

Manual Server Patch Procedure

You can manually control patching the nodes. The manual server patching process requires you to log in to a node and run Oracle Appliance Manager (oakcli) using a local node server patch update. After you complete the patch procedure on the first node, log into the second node, and patch the second node.

1. Download the Oracle Database Appliance server patch bundle from My Oracle Support to Node 0.
2. Log in to Node 0 as the root user.
3. Run the Oracle Appliance Manager command `oakcli update -patch version --server --local`, where *version* is the Patch Bundle version.

```
#!/opt/oracle/oak/bin/oakcli update -patch 12.2.1.3.0 --server --local
```

The Oracle Appliance Manager command carries out the patch on Node 0. As the patch runs, it displays output that advises you of the installation progress.

4. Oracle Appliance Manager prompts you to restart the node. Restart the node, and wait until Node 0 shuts down and completes restarting before proceeding to the next step.
5. Log out of Node 0, and log in to Node 1 as the root user.
6. Run Oracle Appliance Manager on Node 1 using the `--local` flag to patch the server.

For example:

```
#!/opt/oracle/oak/bin/oakcli update -patch 12.2.1.3.0 --server --local
```

7. Oracle Appliance Manager prompts you to restart the node. Restart the node, and wait until Node 0 shuts down and completes restarting.

When both servers are patched and restarted, proceed to the next step.

Related Topics

- [oakcli orachk](#) (page 5-46)
Use the `oakcli orachk` command to audit configuration settings with the ORAchk utility.
- [oakcli update](#) (page 5-75)
Use the `oakcli update` command to apply Oracle Database Appliance patches.

1.3.6 Step 5: Patch the Shared Storage (Optional)

Use this procedure to patch the shared storage now, or during a maintenance window.

Patching the storage requires downtime when shared components are being patched and might require rebooting the nodes.

The storage patch updates shared storage, including the Controller (`Control_EXT`), SSD (`SSD_SHARE`), HDD (`HDD_SHARE`), and Expander. While not required, Oracle recommends patching storage.

Do not apply the storage patch until the server is successfully patched on both nodes.

Before patching, run the command `oakcli update -patch release --verify`, where `release` is the Patch Bundle version, and review the output:

- If "Up-to-date" appears in the Proposed Patch Version for the `Control_EXT`, `SSD_SHARE`, and `HDD_SHARE` storage components, then you do not need to apply the storage patch.
- If any of the storage components require updating, then stop the Oracle stack on both nodes before patching.

Start the storage patching command only on the first node (Node 0). The command patches storage for both nodes at the same time.

1. Log into Node 0 as the root user.
2. Stop the shared repository on both nodes by running the command `oakcli stop repo repo_name`, where `repo_name` is the name of the shared repository being patched.

```
#!/opt/oracle/oak/bin/oakcli stop repo shared_repol
```

3. Run the command `oakcli update -patch version --storage`, where `version` is the Patch Bundle version.

For example, run the following command to patch storage to release 12.1.2.12.0.

```
#!/opt/oracle/oak/bin/oakcli update -patch 12.1.2.12.0 --storage
```

The storage patch runs, and automatically installs itself on both nodes. The output displayed by the patch process advises you of the installation progress. If you are running this step in sequence, then wait for the patch to complete before proceeding to the next step.

If a failure occurs, then you can restart the patching process by reissuing the same command.

4. Start the shared repository on both nodes by running the command `oakcli start repo repo_name`, where `repo_name` is the name of the shared repository being patched.

```
#!/opt/oracle/oak/bin/oakcli start repo shared_repol
```

1.3.7 Step 6: Patch Oracle Database

Apply the Oracle Database Appliance Patch Bundle to update Oracle Database on Node 0 and Node 1.

1. Run the command `oakcli show databases` on Node 0.

For example:

```
#oakcli show databases
```

Name	Type	Storage	HomeName	HomeLocation	Version
db1	RAC	ASM	OraDb12102_home1	/u01/app/oracle/product/12.1.0.2/dbhome_1	12.1.0.5.0(20831110,20831110)
db2	SINGLE	ASM	OraDb12102_home2	/u01/app/oracle/product/12.1.0.2/dbhome_2	12.1.0.2.160119(21948354,21948344)
db3	RACOneNode	ASM	OraDb12102_home3	/u01/app/oracle/product/12.1.0.2/dbhome_3	12.1.0.5.0(20831110,20831110)
db4	RAC	ASM	OraDb12102_home4	/u01/app/oracle/product/12.1.0.2/dbhome_4	12.1.0.2.160119(21948354,21948344)

 **Note:**

You cannot perform individual database updates for databases running in the same home. All databases running in the homes that you update are patched to the Oracle Database 12c release 1 patch for Oracle Database Appliance (12.1.0.2.180116). For Oracle Database 11.2, the database is patched to 11.2.0.4.180116.

2. Run the `oakcli update -patch version --database` command, on Node 0 only. The command automatically patches both nodes. If you have more than one database home that can be patched, then the software provides a selection list. You can select, one, a set, or all of the Oracle Database homes to upgrade.

```
# oakcli update -patch 12.2.1.3.0 --database
```

3. After the update command completes on both nodes, run the command `oakcli show databases` on Node 0 to verify that the database version is updated.

```
#oakcli show databases
```

1.3.8 Step 7: Validate the Patch Update

Run the command `oakcli show version -detail` to verify that all components of the Oracle Database Appliance patch installation are updated.

When you apply the patch and then run the command `oakcli show version -detail`, the output shows the installed version and that the supported versions are Up-to-date. If you unpack the patch bundle (`oakcli unpack -pack`) and then run the command `oakcli show version -detail` before applying the patch, the output shows that the supported versions are No-update.

To confirm that your Oracle Grid Infrastructure and Oracle Database software components are updated, run the following command:

```
# /opt/oracle/oak/bin/oakcli show version -detail
```

```
Mon May 23 03:31:48 PST 2017
Reading the metadata. It takes a while...
System Version   Component Name   Installed Version   Supported Version
-----
12.2.1.3.0
Controller_INT   4.650.00-7176   Up-to-date
Controller_EXT   13.00.00.00     Up-to-date
Expander         0291            Up-to-date
SSD_SHARED {
```

[c2d20,c2d21,c2d22, c2d23]	A29A	Up-to-date
[c2d0,c2d1,c2d2,c2d 3,c2d4,c2d5,c2d6,c2d 7,c2d8,c2d9,c2d10,c2 d11,c2d12,c2d13,c2d1 4,c2d15,c2d16,c2d17, c2d18,c2d19]	A29A	Up-to-date
SSD_LOCAL	A29A	Up-to-date
ILOM	4.0.2.20.b-es-r123704	Up-to-date
BIOS	41021300	Up-to-date
IPMI	1.8.12.4	Up-to-date
HMP	2.4.1.0.9	Up-to-date
OAK	12.2.1.3.0	Up-to-date
OL	6.9	Up-to-date
GI_HOME	12.1.0.2.170418(2400 6101,23854735)	Up-to-date
DB_HOME	12.1.0.2.170418(2305 4246,23054327)	Up-to-date

1.4 Performing a Bare Metal Restore

Reimage Oracle Database Appliance to perform a bare metal restore of Oracle Database Appliance.

- [About Performing a Bare Metal Restore](#) (page 1-15)
Bare metal operating system (OS) re-imaging installs Oracle Database Appliance operating system software on the local (boot) drive.
- [Downloading an ISO Image for Bare Metal Restore](#) (page 1-16)
Download the Oracle Database Appliance Bare Metal ISO image on your local machine.
- [Re-imaging Oracle Database Appliance](#) (page 1-16)
Re-image Oracle Database Appliance to perform a bare metal restore of Oracle Database Appliance.

1.4.1 About Performing a Bare Metal Restore

Bare metal operating system (OS) re-imaging installs Oracle Database Appliance operating system software on the local (boot) drive.

Bare Metal is a non-virtualized Oracle Database Appliance configuration. Oracle Database Appliance ships from the factory with a bare metal configuration, default ISO image and Appliance Manager installed.

Use the OS ISO Image to restore the OS to the "shipped from factory" state. Use only when necessary. Reimaging does not patch the firmware or update the component

versions, it only re-images the local system disk from an OS perspective. After imaging is completed, redeploy the End User image, then restore from backup, as needed.

The following are some of the reasons that you might want to reimage to perform a bare metal restore:

- Deploy Bare Metal with latest Oracle Database Appliance software.
In some cases, the Oracle Database Appliance machine is shipped from the factory with an earlier release of Oracle Database Appliance software. To deploy the machine with the latest software, you can perform an update or you can reimage the machine.
- Roll back to an earlier version of Oracle Database Appliance software.
Re-imaging with older release of Oracle Database Appliance software does not rollback the firmware version.

Use the Oracle Integrated Lights Out Manager (ILOM) interface to reimage the Oracle Database Appliance node.

1.4.2 Downloading an ISO Image for Bare Metal Restore

Download the Oracle Database Appliance Bare Metal ISO image on your local machine.

Download patch 12999313 for the Oracle Database Appliance Bare Metal ISO Image to prepare for a bare metal restore for Oracle Database Appliance.

1. Log into My Oracle Support.
2. Download the Oracle Database Appliance 12.2.1.3.0 Bare Metal ISO Image and extract the files.
 - a. Locate patch 12999313 for the Oracle Database Appliance Bare Metal ISO Image.

<https://updates.oracle.com/download/12999313.html>

- b. Select the patch version for release 12.2.1.3.0.

- c. Click **Download** to download the zip file.

p12999313_122130_Linux-x86-64.zip

- d. Extract the files.

```
#unzip p12999313_122130_Linux-x86-64.zip
```

Related Topics

- <https://updates.oracle.com/download/12999313.html>

1.4.3 Re-imaging Oracle Database Appliance

Re-image Oracle Database Appliance to perform a bare metal restore of Oracle Database Appliance.

Bare metal restore uses Oracle Integrated Lights Out Manager (ILOM) to reimage the Oracle Database Appliance node. For Oracle Database Appliance models earlier than X5-2, go to My Oracle Support and locate MOS Note 1373599.1.

 **Note:**

Bare metal OS re-imaging is specific to the node on which the procedure is executed and overwrites the local storage (operating system) on that node. You must reimage both nodes.

 **Note:**

To use Oracle Database Appliance Virtualized Platform, you must reimage Oracle Database Appliance with the virtualized VM ISO image and the VM Template instead of the OS ISO image.

Newer ILOM versions require that the Java client be on `jre-7-linux-i586.rpm` or higher to be able to launch the remote console.

Download the Oracle Database Appliance Bare Metal ISO image to your local machine before you launch the ILOM console.

1. Open a browser and connect to Oracle Integrated Lights Out Manager (ILOM) on Node 0 as root.
2. Launch the Remote Console.
 - a. Expand **Remote Control** in the left navigation.
 - b. Click the **Redirection** tab.
 - c. Click **Launch** for the Remote Console in the Actions menu.

The state of the system determines what appears on the Console page.
3. Add the image.
 - a. Click the **KVMS** tab, then select **Storage**.
 - b. Click **Add**.
 - c. Browse to the Oracle Database Appliance Bare Metal ISO Image, highlight the image, then click **Select**.
 - d. Click **Connect**.

The mounting of the ISO image is successful when the **Connect** button changes to a **Disconnect** button.
 - e. Click **OK**

The CD-ROM icon in the top right corner is highlighted.
4. Configure the CD-ROM as the next boot device.
 - a. Expand **Host Management** in the left menu of the ILOM Remote Console tab.
 - b. Click **Host Control**.
 - c. Select **CDROM** from the Next Boot Device menu, then click **Save**.
5. Power cycle the node.
 - a. Click **Power Control** in the **Host Management** menu.
 - b. Select **Power Cycle** , then click **Save**.

When the node comes back after the power cycle, re-imaging starts automatically. The Oracle Linux page appears, followed by the Running Post-Install scripts page.

The Running Post-Install scripts page is a static page and might give the impression that the reimaging process is not progressing. The post-install process during reimaging will wait until the synchronization between the partitions of the two mirrored local hard disks is complete, which can take 15 to 20 minutes to complete.

To check the progress of resynchronization, press the ALT-F2 key combination to open a second console and enter the following command:

```
# cat /proc/mdstat
```

When the resynchronization is complete, re-imaging is completed and the machine restarts.

6. Repeat the procedure for Node 1.

Reimaging is node specific. You must reimage both nodes.

7. After re-imaging both nodes, verify that the installed version and supported version are up-to-date for each component on Oracle Database Appliance.

```
# /opt/oracle/oak/bin/oakcli show version -detail
```

8. If components are not up-to-date, update the components to the latest version.

Related Topics

- [Downloading an ISO Image for Bare Metal Restore](#) (page 1-16)
Download the Oracle Database Appliance Bare Metal ISO image on your local machine.

2

Managing Oracle Database on Oracle Database Appliance

This chapter describes how to create and manage databases on Oracle Database Appliance. It also covers how to use Oracle Database Appliance solid-state drives (SSDs) and how to update and upgrade Oracle Database on Oracle Database Appliance.

Topics:

- [About the Oracle Database Appliance OAKCLI Utility](#) (page 2-1)
Manage and maintain Oracle Database Appliance components using the Oracle Appliance Manager Command-Line Utility (OAKCLI).
- [Oracle Database Features and Oracle Database Appliance](#) (page 2-2)
Review the Oracle Database features that are available with Oracle Database Appliance.
- [Creating and Converting Databases with OAKCLI](#) (page 2-6)
Use the Oracle Appliance Manager Command Line Interface (OAKCLI) to create and manage databases on Oracle Database Appliance.
- [About Managing Multiple Databases on Oracle Database Appliance](#) (page 2-9)
Review this topic to understand Oracle requirements for multiple Oracle home support.
- [About Managing Multiple Database Instances Using Instance Caging](#) (page 2-11)
Use instance caging to manage your system resources on Oracle Database Appliance.
- [About Oracle Database Appliance SSDs](#) (page 2-12)
Oracle Database Appliance includes solid-state drives (SSDs) to enhance storage performance.
- [How to Upgrade and Update the Oracle Database on Oracle Database Appliance](#) (page 2-14)
Review the information in these topics to select the procedure for upgrading and updating your Oracle Database release.

2.1 About the Oracle Database Appliance OAKCLI Utility

Manage and maintain Oracle Database Appliance components using the Oracle Appliance Manager Command-Line Utility (OAKCLI).

Oracle Database Appliance provides its own command-line tool, OAKCLI, to manage all components on the system. Use OAKCLI commands for the following tasks:

- Create, upgrade, and patch databases
- Create and upgrade Oracle homes
- Create and modify database creation parameter files

Many tasks related to managing Oracle Databases are also required with databases on Oracle Database Appliance. Tasks common to Oracle Database generally are described in the Oracle Database documentation library. However, to simplify database creation and related tasks, use the OAKCLI utility. The OAKCLI utility combines the capabilities of the SYS database administrator role and the operating system Superuser (`root` user). Always perform administrative tasks using the OAKCLI utility.

▲ Caution:

Do not use Oracle Database Configuration Assistant (DBCA) to create databases on Oracle Database Appliance. Only use Oracle Appliance Manager for database configuration. Deploying Oracle Database instances using Oracle Appliance Manager ensures that these databases are properly configured, optimized, and supported on Oracle Database Appliance.

2.2 Oracle Database Features and Oracle Database Appliance

Review the Oracle Database features that are available with Oracle Database Appliance.

Topics:

- [Oracle Database Appliance Plug-in for Oracle Enterprise Manager](#) (page 2-3)
Use the Oracle Database Appliance plug-in for Oracle Enterprise Manager to monitor Oracle Database Appliance targets that are configured in Oracle Database Enterprise Edition.
- [Oracle EM Express and DB Console](#) (page 2-3)
You can use Oracle Enterprise Manager Database Express (EM Express), or the Database Control Console (DB Console) to manage your database.
- [Data Migration and Management and Oracle Database Appliance](#) (page 2-3)
Oracle Database Appliance supports the use of standard Oracle Database loading and migration tools.
- [Oracle Clusterware and Oracle Database Appliance](#) (page 2-4)
Oracle Clusterware provides the clustering infrastructure for Oracle Database Appliance.
- [Oracle RAC One Node and Oracle Database Appliance](#) (page 2-4)
Oracle RAC One Node is available with Oracle Database Appliance.
- [Oracle Real Application Clusters and Oracle Database Appliance](#) (page 2-4)
Oracle Database Appliance supports administrator-managed Oracle RAC Databases.
- [Administrative Groups and Users on Oracle Database Appliance](#) (page 2-5)
Oracle Database Appliance configuration creates operating system groups and users whose members are granted system administration privileges on the appliance.

2.2.1 Oracle Database Appliance Plug-in for Oracle Enterprise Manager

Use the Oracle Database Appliance plug-in for Oracle Enterprise Manager to monitor Oracle Database Appliance targets that are configured in Oracle Database Enterprise Edition.

When you install the Oracle Database Appliance plug-in with Oracle Enterprise Manager Cloud Control 12c or Oracle Enterprise Manager Cloud Control 13c, you can monitor Oracle Database Appliance targets. The plug-in provides configuration and monitoring information about any Oracle Database Appliance target running Appliance Manager 12.1.2.2 or later.

See *Oracle Enterprise Manager Plug-in for Oracle Database Appliance User's Guide* for more information about the plug-in.

Related Topics

- http://docs.oracle.com/cd/E70264_01/index.htm

2.2.2 Oracle EM Express and DB Console

You can use Oracle Enterprise Manager Database Express (EM Express), or the Database Control Console (DB Console) to manage your database.

The EM Express console is available for Oracle Database 12.2.0.1 or 12.1.0.2. The DB Console is available for Oracle Database 11.2.0.4. Both consoles are web-based tools for managing Oracle Databases.

The EM Express console provides the following features:

- Support for basic administrative tasks, such as storage and user management
- Comprehensive solutions for performance diagnostics and tuning
- Performance advisors in a graphic user interface
- Oracle Database utilities in a graphic user interface, such as SQL*Loader and Oracle Recovery Manager (RMAN)

EM Express is built inside the database server and cannot perform actions outside the database.

2.2.3 Data Migration and Management and Oracle Database Appliance

Oracle Database Appliance supports the use of standard Oracle Database loading and migration tools.

If you are loading data or migrating data from an existing database to Oracle Database Appliance, then you can use the standard Oracle Database loading and migration tools. These tools include the following:

- Oracle GoldenGate
- SQL*Loader

- Oracle Data Pump
- transportable tablespaces
- RMAN

You can also use the RMAN utility to back up and recover databases on Oracle Database Appliance.

2.2.4 Oracle Clusterware and Oracle Database Appliance

Oracle Clusterware provides the clustering infrastructure for Oracle Database Appliance.

Oracle Clusterware provides the cluster technology required for Oracle Real Application Clusters (Oracle RAC). In addition, Oracle Clusterware manages applications and processes as resources that you register with Oracle Clusterware, to provide high availability services. The number of resources that you register with Oracle Clusterware to manage an application depends on the application. Applications that consist of only one process are usually represented by only one resource. More complex applications that use multiple processes or components can require multiple resources to maintain high availability.

Related Topics

- [Making Applications Highly Available Using Oracle Clusterware](#)

2.2.5 Oracle RAC One Node and Oracle Database Appliance

Oracle RAC One Node is available with Oracle Database Appliance.

Oracle Real Application Clusters One Node (Oracle RAC One Node) is a single instance of an Oracle RAC database that runs on one node in a cluster. Instead of stopping and starting instances, you can use the Oracle RAC One Node online database relocation feature to relocate an Oracle RAC One Node instance to another server.

Administration of Oracle RAC One Node databases on Oracle Database Appliance is different from administering Oracle RAC or single-instance Oracle Databases. For Oracle RAC One Node databases, one node is the primary node, and the other node is a candidate node, which is available to accommodate services if the primary node fails, or is shut down for maintenance. The nodes, Oracle Databases, and database services reside in the generic server pool.

Related Topics

- [Administering Oracle RAC One Node](#)

2.2.6 Oracle Real Application Clusters and Oracle Database Appliance

Oracle Database Appliance supports administrator-managed Oracle RAC Databases.

Oracle Real Application Clusters (Oracle RAC) provides technology that links two or more individual computers so that they function as one system. Oracle RAC deployed on Oracle Database Appliance enables each node to share access to a database. If one node fails or is taken offline, then the other node continues operating and the entire Oracle RAC database remains available.

Oracle Database Appliance currently supports only administrator-managed databases, where the database administrator allocates each instance of the database to a specific node in the cluster. Oracle Database Appliance does not support Policy-managed databases, where the database administrator defines the number of database instances required, but not the nodes where they run.

When you review the database resource for an administrator-managed database, you see a server pool defined with the same name as the Oracle Database. This server pool is part of a special Oracle-defined server pool, called the Generic server pool. The Generic server pool stores any server that is not in a top-level server pool and is not policy managed. Servers that host administrator-managed databases are statically assigned to the Generic server pool. Oracle RAC manages the Generic server pool to support administrator-managed databases. You cannot use SRVCTL or Oracle Clusterware Control (CRSCTL) utility commands to modify the Generic server pool.

2.2.7 Administrative Groups and Users on Oracle Database Appliance

Oracle Database Appliance configuration creates operating system groups and users whose members are granted system administration privileges on the appliance.

During configuration, two administrative accounts are created for Oracle Database Appliance: the user `grid`, with a user ID (UID) of 1000, and the user `oracle`, with a UID of 1001. The user `grid` is the Oracle Grid Infrastructure installation owner. The user `oracle` is the Oracle Database installation owner, and the owner of all Oracle Database homes (Oracle homes). By default, these users are members of operating system groups whose members are granted privileges to start up and administer Oracle Database and Oracle Automatic Storage Management.

The following table describes the Oracle system privileges groups, and information about the operating system authentication groups:

Table 2-1 Operating System Groups and Users on Oracle Database Appliance

Oracle System Privileges	Group Name	Group ID (GID)	<i>grid</i> is a member	<i>oracle</i> is a member
Oracle Inventory group (OINSTALL)	<code>oinstall</code>	1001	yes (primary group)	yes (primary group)
OSDBA group	<code>dba</code>	1002	no	yes
OSOPER for Oracle RAC group	<code>racoper</code>	1003	yes	yes
OSDBA for ASM group	<code>asmdba</code>	1004	yes	yes
OSOPER for ASM group	<code>asmoper</code>	1005	yes	no
OSASM Group for Oracle ASM	<code>asmadmin</code>	1006	yes	no

If you create an initial database during deployment, then the password for the `sys` and `SYSTEM` users is the same. Change this password for both users as soon as possible after configuration to prevent unauthorized access to your database using these privileged accounts.

2.3 Creating and Converting Databases with OAKCLI

Use the Oracle Appliance Manager Command Line Interface (OAKCLI) to create and manage databases on Oracle Database Appliance.

Topics:

- [About Creating Databases with OAKCLI Commands](#) (page 2-6)
Create additional Oracle Databases using the Oracle Appliance Manager Command-Line Utility (OAKCLI) to ensure that your database is configured optimally for Oracle Database Appliance.
- [Creating, Using, and Removing Database Configuration Files with OAKCLI](#) (page 2-7)
You can use OAKCLI to create and use configuration files to deploy databases on Oracle Database Appliance. Also use OAKCLI to remove unwanted configuration files.
- [Creating Snapshot Databases With OAKCLI](#) (page 2-8)
You can use OAKCLI to create snapshot databases.
- [About Converting Single-Instance Databases to Oracle RAC or Oracle RAC One Node](#) (page 2-9)
Oracle provides utilities to enable you to convert your existing single-instance databases to Oracle Real Application Clusters or Oracle RAC One Node databases.

2.3.1 About Creating Databases with OAKCLI Commands

Create additional Oracle Databases using the Oracle Appliance Manager Command-Line Utility (OAKCLI) to ensure that your database is configured optimally for Oracle Database Appliance.

OAKCLI assists you to deploy Oracle Databases that follow Optimal Flexible Architecture guidelines. The Optimal Flexible Architecture standard provides best practices configurations to help to ensure database deployments that are easier to support and maintain. Optimal Flexible Architecture includes the following

- Structured organization of directories and files, and consistent naming for critical database files, such as control files, redo log files, and other critical files, which simplifies database administration.
- Separation of tablespace contents to minimize tablespace free space fragmentation, and maximize administrative flexibility
- Stripe and Mirror Everything (SAME) deployment, which safeguards against database failures

Refer to "Optimal Flexible Architecture" in *Oracle Database Installation Guide for Linux* for more information about Optimal Flexible Architecture.

Start the OAKCLI utility by using the command `oakcli create database` to create additional databases on Oracle Database Appliance.

When you run this command, respond to each prompt by entering the number that corresponds with the option you want to apply to your database. When a default is supplied, and the default is the value you want to use (typically shown as option 1),

click Enter to accept that value. When there are many options, and the value you want is not displayed, press 0 to show all of the options.

Related Topics

- [Optimal Flexible Architecture](#)

2.3.2 Creating, Using, and Removing Database Configuration Files with OAKCLI

You can use OAKCLI to create and use configuration files to deploy databases on Oracle Database Appliance. Also use OAKCLI to remove unwanted configuration files.

Use the Oracle Appliance Manager Command-Line Utility (OAKCLI) `ommand` option `oakcli create db_config_params` to create a configuration file that you can use to configure multiple Oracle Database deployments. The command uses the following syntax, where `params_file` is the name of the configuration file that you want to create:

```
oakcli create db_config_params params_file
```

When you run `oakcli create db_config_params`, you are prompted to select one of a set of available parameter setting options to use in the configuration file. Respond to each prompt by entering the number that corresponds to the configuration that you want to use to set up your databases. If there is a default value, and you want to use this value (typically option **1**), then press **Enter** to accept that value. If there are many options, then you may need to select option **0** to show all of the available parameter options.

To see your existing database configuration files, use the command `oakcli show db_config_params` command. For example

```
# oakcli show db_config_params
Available DB configuration files are:
default
eurodbs
4kblockdbs
mytest.params
```

Configuration files using the default extension `.dbconf` do not show the extension in this command output. Oracle recommends that you use this default file extension to simplify file management. If you create a configuration file that does not use the `.dbconf` default extension, then the nondefault extension is shown as part of the output of `oakcli show db_config_params`.

To use a database configuration file to create a single Oracle Database, or to use the command to create many Oracle Database instances with the identical profile, use the following command syntax, where `db_name` is the name of the database that you want to create, and `params_file` is the name of the parameter configuration file that you want to use to configure the database:

```
oakcli create database -db db_name -params params_file
```

For example, this command creates the database named `myxldb`, using the parameter configuration file `myxldb.dbconf`:

```
oakcli create database -db myxldb -params myxldb.dbconf
```

After you have completed using configuration files, you can delete files that you do not plan to use again.

Remove unwanted database configuration files using the following command syntax, where *params_file* is the name of the parameter configuration file that you want to delete:

```
oakcli delete db_config_params params_file
```

As with other Oracle Database Appliance Manager commands related to database configuration files, you do not need to include the parameter configuration filename extension if your file has the default extension value, which is `.dbconf`.

2.3.3 Creating Snapshot Databases With OAKCLI

You can use OAKCLI to create snapshot databases.

An Oracle snapshot database is created by taking a snapshot of the Oracle ASM Cluster File System (Oracle ACFS) where the source data files reside. The source database can be a single instance, Oracle RAC, or Oracle RAC One Node. Compared to other methods of creating copies of databases, snapshot databases require less time and storage space and involve no downtime of the source database. Additionally, you can create any database type and class from any other type and class. For example, you can create an Oracle RAC database from an Oracle RAC One Node database. Similarly, you can create a database that is different in size than the source database.

On Oracle Database Appliance, you can create snapshot databases from any Oracle Database instance stored on Oracle ACFS. Beginning with Oracle Database Appliance release 12.1.2.0.0, you can create snapshot databases with Oracle Database 11g release 2 (11.2.0.4) or later databases created or upgraded on the system.

Snapshot database candidates must meet the following requirements:

- They must not be a standby or container database
- They must not be running in read-only mode, or in restricted mode, or in online backup mode
- They must be in ARCHIVELOG mode
- They must have all defined data files available and online
- They must not use centralized wallets with Transparent Data Encryption.

Also, ensure that the system clocks on the two Oracle Database Appliance nodes are synchronized before you create a snapshot database. If the clocks are significantly different, then the command can fail.

To create a snapshot database, use the command `oakcli create snapshotdb`. The following example creates a snapshot database named `snapprod` from the database named `prod`.

```
oakcli create snapshotdb -db snapprod -from prod
```

 **Caution:**

Oracle Database Appliance does not support centralized wallets with Transparent Data Encryption. Recovery of encrypted data may fail in the snapshot database if the source database relies on an external, centralized wallet.

2.3.4 About Converting Single-Instance Databases to Oracle RAC or Oracle RAC One Node

Oracle provides utilities to enable you to convert your existing single-instance databases to Oracle Real Application Clusters or Oracle RAC One Node databases.

Use the procedures for converting your single-instance database as described in *Oracle Real Application Clusters Administration and Deployment Guide*. You can convert a single-instance database either to Oracle Real Application Clusters (Oracle RAC), or to Oracle RAC One Node.

For example, you can use RCONFIG to convert your single instance Oracle Database.

Open the template file `ConvertToRAC_AdminManaged.xml`, and modify it as required for your migration, in accordance with the instructions in the file. Then save the file with a new filename. The information you provide determines how your converted database is configured. The template file is located in the following path:

```
$ORACLE_HOME/sampleXMLs/ConvertToRAC_AdminManaged.xml
```

Refer to the section "Converting Single-Instance Oracle Databases to Oracle RAC and Oracle RAC One Node" in *Oracle Real Application Clusters Installation and Configuration Guide* for more information.

2.4 About Managing Multiple Databases on Oracle Database Appliance

Review this topic to understand Oracle requirements for multiple Oracle home support.

The Oracle home is the directory in which you install Oracle Database binaries, and from which Oracle Database runs. Use Oracle Appliance Manager OAKCLI commands to create and manage multiple Oracle homes and databases on Oracle Database Appliance. Oracle Database Appliance Manager automatically creates an Oracle Database Oracle home that is compliant with Oracle's Optimal Flexible Architecture (OFA) standards.

Oracle Database Appliance supports multiple Oracle homes, including support of different release Oracle Database homes. Check the related `readme` files or the Release Notes to obtain information about the specific Oracle software releases supported for your Oracle Database Appliance platform.

When you use OAKCLI commands to create multiple homes on Oracle Database Appliance, the commands start the Oracle Grid Infrastructure cloning process. In Oracle Database Appliance deployments, the user `oracle` is the software installation owner account that owns the Oracle homes.

 **Note:**

If you are not upgrading from an earlier release, then download the Oracle Database Appliance End-User Bundle for the Oracle Database version that you want to install.

Use OAKCLI commands to create, manage, patch, and upgrade multiple databases on Oracle Database Appliance. The command `oakcli create database` enables you to create a database with minimal user input. When you run this command without any additional options, the command creates a new database home. You can also create a database in an existing home by running the command `oakcli create database -oh oracle_home`, where *oracle_home* is the Oracle home in which you want to create the Oracle Database.

 **Caution:**

Do not apply Oracle Database patches directly to Oracle Databases on Oracle Database Appliance. Only use Oracle Database Appliance patch bundles, which are tested to work across the whole software stack.

Only use `oakcli` commands to create new databases in either existing Oracle homes, or in new Oracle homes.

- [Downloading an End-User RDBMS Clone File](#) (page 2-10)
Download an Oracle Database Appliance End-User RDBMS Clone file onto your local machine to create a new database home.

Related Topics

- [Downloading an ISO Image for Bare Metal Restore](#) (page 1-16)
Download the Oracle Database Appliance Bare Metal ISO image on your local machine.

2.4.1 Downloading an End-User RDBMS Clone File

Download an Oracle Database Appliance End-User RDBMS Clone file onto your local machine to create a new database home.

This software clone file contains the Oracle Database software images for Oracle Database Appliance X5-2, X4-2, X3-2, and V1.

There are no base clone files for 12.1.0.2.170117, 11.2.0.4.161018, or 11.2.0.3.15. In an environment patched to at least Oracle Database Appliance 12.1.2.10.0, you can update the existing database to 12.1.0.2.170117, 11.2.0.4.161018, or 11.2.0.3.15.

Perform the following steps to create new dbhomes for these releases:

1. Download 12.1.0.2.170117, 11.2.0.4.161018, or 11.2.0.3.15 clone file.
2. Unpack the clone file with the command `oakcli unpack -package`.
3. Create a new dbhome for 12.1.0.2.170117, 11.2.0.4.161018, or 11.2.0.3.15.

```
# oakcli create dbhome -version <version_number>
```

4. Create the databases for the new dbhome.

Before you transfer these files to Oracle Database Appliance, complete the hardware setup and configure the public network interface on Oracle Database Appliance.

1. From an external client machine, log on to My Oracle Support.
2. Select the Oracle Database Appliance End-User RDBMS Clone file (Patch) for the supported Oracle Database version.
 - 12.1.0.2.170117: Patch 19520042. Select **12.1.2.10.0** from the Release drop down box.
 - 11.2.0.4.161018: Patch 17770873. Select **12.1.2.9.0** from the Release drop down box.
 - 11.2.0.3.15: Patch 14777276. Select **12.1.2.4.0** from the Release drop down box. Oracle Database 11.2.0.3.x is only supported on X5-2, X4-2, X3-2, and V1 models.
 - 11.2.0.2.12: Patch 14349293. Select **2.8.0.0.0** from the Release drop down box. Oracle Database 11.2.0.2.12 is only supported on X4-2, X3-2, and V1 models.
3. Click **Download** to download the zip file onto your external client.
4. Use either a Secure Copy (scp) command or a USB storage device to copy the file from the external client to `dom0` on Node 0. Use the `/OVS` directory as the target location.



Note:

If you use a USB drive to transfer the file, then format it first as `FAT32`, `ext3`, or `ext4`. NTFS file formats are not supported.

5. When you extract the files, use the command `oakcli unpack -package`.

Related Topics

- <https://updates.oracle.com/download/19520042.html>
- <https://updates.oracle.com/download/17770873.html>
- <https://updates.oracle.com/download/14777276.html>
- <https://updates.oracle.com/download/14349293.html>

2.5 About Managing Multiple Database Instances Using Instance Caging

Use instance caging to manage your system resources on Oracle Database Appliance.

Oracle Database provides a method for managing CPU allocations on a multi-CPU server that runs multiple database instances. This method is called instance caging. Instance caging uses an initialization parameter to limit the number of CPUs that an instance can use simultaneously.

Instance caging and Oracle Database Resource Manager (the Resource Manager) work together to support your desired service levels across multiple instances. Consolidation can minimize idle resources, maximize efficiency, and lower costs.

Oracle Database Appliance templates are already tuned for the size of each database instance workload. They are designed to run on a specific number of cores. Instance caging ensures that each database workload is restricted to the set of cores allocated by the template, enabling multiple databases to run concurrently with no performance degradation, up to the capacity of Oracle Database Appliance. You can select database template sizes larger than your current needs to provide for planned growth.

 **Note:**

Oracle strongly recommends that you use the Oracle Database Appliance templates, because they implement best practices and are configured specifically for Oracle Database Appliance.

The Oracle Database Appliance Manager interface refers to the database sizing templates as database classes.

By default, instance caging is not enabled on Oracle Database Appliance. To enable instance caging, set the initialization parameter, `RESOURCE_MANAGER_PLAN`, for each database on Oracle Database Appliance. The parameter specifies the plan to be used by the Resource Manager for the current instance. Setting this parameter directs the Resource Manager to allocate core resources among databases. If a plan is not specified with this parameter, then the Resource Manager and instance caging are not enabled.

Instance caging allocation of core resources is enabled in accordance with the Oracle Database Appliance database template size that you select for each database. The `CPU_COUNT` initialization parameter is set in the template. Use the `CPU_COUNT` setting that matches the size of each database to consolidate, and follow the standard instructions for configuring instance caging.

2.6 About Oracle Database Appliance SSDs

Oracle Database Appliance includes solid-state drives (SSDs) to enhance storage performance.

Oracle Database Appliance includes solid-state drives (SSDs) to enhance the performance of certain operations. SSDs increase the speed of storage operations by accelerating redo log writes, caching database data more efficiently than standard disk drives, and improving read/write (I/O) performance for database files.

Accelerating Redo Log Writes

Oracle Database Appliance contains four dedicated SSDs in slots 20 through 23 specifically for database redo logs. An Oracle ASM disk group named `+REDO` with High Redundancy is provisioned during the deployment process to accelerate database redo log write operations and improve latency. Databases automatically utilize these SSDs, and no other files can be hosted on them.

Caching Database Data

Oracle Database Appliance X5-2 introduces four additional 400 GB SSDs in slots 16 through 19 that can be used to host database files, or as a database flash cache in addition to the buffer cache.

An Oracle ASM disk group named +FLASH with Normal Redundancy is provisioned on these SSDs. All of the storage in the +FLASH disk group is allocated to an Oracle ASM Dynamic Volume (flashdata), and formatted as an Oracle ACFS file system. Storage in this flashdata file system is then made available as an Oracle ACFS file system and is used to create database flash cache files that accelerate read operations. The file that contains the flash cache is automatically created for each database and is specified using the database `init.ora` parameter `db_flash_cache_file`. By default, `db_flash_cache_size` is set to 3 times the size of SGA, up to 196 GB, unless there is not enough space, in which case the size parameter is set to 0. After you change the `db_flash_cache_size` parameter, you must restart the database to use the newly sized flash cache.

Improving I/O Performance for Database Files

Oracle Database Appliance Manager Configurator and Oracle Appliance Manager (OAKCLI) both give you the option to configure your appliance to store entire databases in flash memory using the flash data Oracle ACFS file system on 400 GB SSDs. These SSDs are also used for the database flash cache.

The OAKCLI command `oakcli create database` gives you the option to create the database using the SSD drives for data file storage. If there is not enough space available in the +FLASH disk group, then the `oakcli create database` command does not prompt you with the option to store the database data files on the SSD drives. Database files instead are created automatically in the +DATA disk group. You can also store database data files on both flash and hard disk drives. However, you must manage this storage allocation manually. Oracle recommends that you attempt to manage your files on both flash and hard disk files only if you have an advanced storage administrator understanding of database usage patterns

Your Oracle Database must meet the following requirements to use SSDs for data file storage:

- Oracle Databases must be release 11.2.0.4 or later
- The database types must be OLTP
- Oracle Databases stored completely in the +FLASH storage space must be non-container databases (non-CDBs).
- There must be 160 GB of available space in the +FLASH disk group.

Related Topics

- [Storage on Oracle Database Appliance](#) (page A-6)
Review this section to understand Oracle Database Appliance storage architecture and options and how to determine usable storage.
- [oakcli create database](#) (page 5-23)
Use the `oakcli create database` command to create additional databases on Oracle Database Appliance.
- [Configuring Database Smart Flash Cache](#)

2.7 How to Upgrade and Update the Oracle Database on Oracle Database Appliance

Review the information in these topics to select the procedure for upgrading and updating your Oracle Database release.

Topics:

- [About Oracle Database Upgrades and Updates on Oracle Database Appliance](#) (page 2-14)
Use Oracle Database Appliance bundles to upgrade or update Oracle Database instances, as well as other components and features of Oracle Database Appliance.
- [Updating to Oracle Database 12.1.0.2.161018 from Previous Oracle Database 12.1.0.2.x Releases](#) (page 2-15)
Use this example to understand steps required to update Oracle Database 12c release 1 (12.1) releases on Oracle Database Appliance.
- [Upgrading to Oracle Database 12.1.x from Oracle Database 11.2.0.4.x Releases](#) (page 2-16)
Use this example to understand steps required to update Oracle Database 12c release 1 (12.1) releases on Oracle Database Appliance.
- [Upgrading to Oracle Database 11.2.0.4.161018 from Oracle Database 11.2.0.4.x Releases](#) (page 2-18)
Use this example to understand steps required to upgrade Oracle Database 11g release 2 (11.2) releases on Oracle Database Appliance.

2.7.1 About Oracle Database Upgrades and Updates on Oracle Database Appliance

Use Oracle Database Appliance bundles to upgrade or update Oracle Database instances, as well as other components and features of Oracle Database Appliance.

Oracle Database Appliance upgrades and updates use specially developed Oracle Database Appliance patch bundles. Only use these patch bundles to perform upgrades and updates on Oracle Database Appliance.

Use the appropriate Oracle Database Appliance patch bundle for your appliance. Typically, Oracle recommends that you use the latest Oracle Database Appliance patch bundle.

Oracle Database Appliance patch bundles can include updates and upgrades to Oracle Database software, and updates and upgrades to other components of Oracle Database Appliance, including updates to Infrastructure (*infra*) and Grid Infrastructure (*gi*) components.

For information about Oracle Database Appliance Patch Bundles, known issues, and workarounds, see the *Oracle Database Appliance Release Notes*. Also refer to the patch `readme` file.

Related Topics

- Oracle Database Appliance X5-2

- Oracle Database Appliance X4-2
- Oracle Database Appliance X3-2
- Oracle Database Appliance V1

2.7.2 Updating to Oracle Database 12.1.0.2.161018 from Previous Oracle Database 12.1.0.2.x Releases

Use this example to understand steps required to update Oracle Database 12c release 1 (12.1) releases on Oracle Database Appliance.

You use Oracle Appliance Manager (OAKCLI) to update Oracle Database installations. In this scenario, you have updated two databases to Oracle Database 12c release 1 12.1.0.2.161018 when you ran the Oracle Database Appliance 12.1.2.6 Patch Bundle, but you have not updated two other Oracle Database instances that are patched at Oracle Database 12c release 1 (12.1.0.2.4). This procedure describes how to update databases manually after the patch bundle.

The Oracle Database Appliance Patch Bundle for Oracle Database uses a new numbering sequence. The Oracle Database update for Oracle Database Appliance Patch Bundle 12.1.2.6 is 12.1.0.2.161018.

1. Run the command `oakcli show databases` on Node 0 only. Review the output of this command to confirm that you have databases with the appropriate release number for this update.

The following example shows that there are four databases, db1, db2, db3, and db4:

```
# oakcli show databases
```

Name	Type	Storage	HomeName	HomeLocation	Version
db1	RAC	ACFS	OraDb12102_home1	/u01/app/oracle/product/12.1.0.2/dbhome_1	12.1.0.2.4(20831110,20831110)
db2	SINGLE	ACFS	OraDb12102_home2	/u01/app/oracle/product/12.1.0.2/dbhome_2	12.1.0.2.4(20831110,20831110)
db3	RACOneNode	ACFS	OraDb12102_home3	/u01/app/oracle/product/12.1.0.2/dbhome_3	12.1.0.2.160119(21948354,21948344)
db4	RAC	ACFS	OraDb12102_home4	/u01/app/oracle/product/12.1.0.2/dbhome_4	12.1.0.2.160119(21948354,21948344)

Note:

In this example, the databases are in separate Oracle home locations. This option provides the ability to update individual databases, but requires more administration and storage allocation. Databases in separate homes must be updated individually.

Databases in the same database home require less storage allocation, and can be updated as a group. However, you cannot update individual databases in a shared Oracle database home location.

2. Run the command `oakcli update -patch 12.1.2.9.0 --database` on Node 0 only. When you run this command without specifying a database or a database home, the command automatically patches both nodes.

If you have more than one database home that is a candidate for patching, then the command displays a selection list from which you can pick one, some, or all of the candidate database homes that you want to update.

3. After the update command completes running, run the command `oakcli show databases` on Node 0 again.

The command and output should now look similar to the following example:

```
# oakcli show databases

Name Type      Storage HomeName      HomeLocation      Version
-----
db1 RAC          ACFS   OraDb12102_home1 /u01/app/oracle/product/12.1.0.2/dbhome_1 12.1.0.2.161018(24927502,24340679)
db2 SINGLE       ACFS   OraDb12102_home2 /u01/app/oracle/product/12.1.0.2/dbhome_2 12.1.0.2.161018(24927502,24340679)
db3 RACOneNode ACFS   OraDb12102_home3 /u01/app/oracle/product/12.1.0.2/dbhome_3 12.1.0.2.161018(24927502,24340679)
db4 RAC          ACFS   OraDb12102_home4 /u01/app/oracle/product/12.1.0.2/dbhome_4 12.1.0.2.161018(24927502,24340679)
```

The Oracle Database instances db1 and db2 are now updated to 12.1.0.2.161018.

2.7.3 Upgrading to Oracle Database 12.1.x from Oracle Database 11.2.0.4.x Releases

Use this example to understand steps required to update Oracle Database 12c release 1 (12.1) releases on Oracle Database Appliance.

You use Oracle Appliance Manager (OAKCLI) to update Oracle Database installations. In this scenario, you are upgrading Oracle Database to a higher version, from 11g release 1 (11.2.0.4.170418) to 12c release 1 (12.1.0.2.170418).

While the target home in this example does show an existing database, having a database in the target home is not required. However, for debugging purposes it is recommended to create the target home with a sample RAC database to confirm the target binaries and home on both nodes work as expected. You can remove the RAC database after confirming the database functions as expected on each node. This example includes the steps for collecting diagnostics to review after a successful or failed upgrade.

Note:

Do not use manual database creation scripts, DBCA, or DBUA to upgrade your databases in Oracle Database Appliance. Instead, use the patches provided by Oracle Database Appliance to create and update your databases.

The existing database and database home, and the target database home must all be created using the Oracle Appliance Manager (oakcli) create commands and you must be a root user to upgrade the database.

1. Run the command `oakcli show dbhomes -detail` on Node 0 only.

Review the output of this command to confirm that you have databases with the appropriate release number for this update. The following example shows that there are two databases, db1 and db2

```
[root@oda-n0 ~] # oakcli show dbhomes -detail
Oracle Home Name      Oracle Home Version      Oracle Home
Location              Database Name  Database Type
-----
OraDb11204_home1     11.2.0.4.170418(24732075,23054319) /u01/app/oracle/product/11.2.0.4/
dbhome_1            db1              RAC
OraDb12102_home1     12.1.0.2.170418(25171037,25942196) /u01/app/oracle/product/12.1.0.2/
dbhome_1            db2              RAC
```

2. Set the ENV for the database home to be upgraded from `source_home`.

- a. Open the environment for the database home to be upgraded. This example is updating the database named `db1` in Oracle Home `OraDb11204_home1`.

```
# # . oraenv
```

- b. Choose the Oracle SID = *database to be upgraded*

```
ORACLE_SID = [root] ? db1
```

You are now in the source home for the database to be upgraded.

```
...The Oracle base has been set to /u01/app/oracle...
```

```
[root@oda-n0 ~]#
```

3. Use the `oakcli upgrade database` command to upgrade the database from the current database home to the target database home.

In this example, we are upgrading `db1` from `OraDb11204_home1` to `OraDb12102_home1`.

```
[root@oda-n0 ~]# oakcli upgrade database -db db1 -from OraDb11204_home1 -to OraDb12102_home1
```

4. Review the output of the log file created by the `oakcli upgrade database` command.

```
INFO: 2017...:07:23: Look at the log file '/opt/oracle/oak/log/oda0/tools/12.1.2.11.0/dbupgrade_16203.log' for more details
```

```
Please enter the 'SYS' password :
```

```
Please re-enter the 'SYS' password:
```

```
INFO: 2017...07:52: Upgrading the database 11204. It will take few minutes.
```

```
Please wait...
```

```
...
```

```
...
```

```
SUCCESS: 2017...22:21: Successfully upgraded the database db1
```

Time to completion varies, depending on a number of factors, including the differences between the source version and target version.

When the log file shows that the database is successfully upgraded, you can run a couple of checks to confirm the database upgrade.

5. (Optional) Confirm the database upgrade.
 - a. Run the command `oakcli show databases` on Node 0 and confirm that the database appears in the new home.

In this example, we are upgrading `db1` from `OraDb11204_home1` to

`OraDb12102_home1`.

```
[root@oda-n0 ~]# oakcli upgrade database -db db1 -from OraDb11204_home1 -to OraDb12102_home1
```

- b. Log into `SQLPLUS>` as user `ORACLE` on the upgraded database to confirm that the upgrade scripts have been executed.

```
# su - oracle
```

```
[oracle@oda-n0 bin]$ export ORACLE_HOME=/u01/app/oracle/product/12.1.0.2/dbhome_1/
```

```
[oracle@oda-n0 bin]$ sqlplus
```

```
SQL*Plus: Release 12.1.0.2.0 Production on Mon ... 2017  
Copyright (c) 1982, 2014, Oracle. All rights reserved.
```

```
Enter user-name: / as sysdba
```

```

Connected to: Oracle Database 12c Enterprise Edition Release 12.1.0.2.0 -
64bit Production
With the Partitioning, Real Application Clusters, OLAP, Advanced Analytics
and Real Application Testing options

```

```

SQL> col comp_name format a34
SQL> col status format a7

```

```

SQL> select comp_name,status, version from dba_registry;
COMP_NAME                                STATUS    VERSION
-----
Oracle XML Database                      VALID     12.1.0.2.0
Oracle Workspace Manager                 VALID     12.1.0.2.0
Oracle Database Catalog Views           VALID     12.1.0.2.0
Oracle Database Packages and Types     VALID     12.1.0.2.0
Oracle Real Application Clusters        VALID     12.1.0.2.0

```

```

SQL> select count(*) from dba_objects where status = 'INVALID';    -- Check
for invalids and compile as needed

```

If this is an Oracle RAC database, repeat this step on the second node (Node 1). If the checks are valid, the database is upgraded.

If the checks are not valid or if there are any problems or failures during a database upgrade, submit a Service Request ticket and include the following information:

- Log file created by the `oakcli upgrade database` command in Step 4.
- All commands in clear text from setting the database home and `. oraenv` through the upgrade steps.
- Oracle Trace File Analyzer (TFA) or `oakcli manage diagcollect` output from before the upgrade through the upgrade to completion or failure.

2.7.4 Upgrading to Oracle Database 11.2.0.4.161018 from Oracle Database 11.2.0.4.x Releases

Use this example to understand steps required to upgrade Oracle Database 11g release 2 (11.2) releases on Oracle Database Appliance.

You use Oracle Appliance Manager (OAKCLI) to upgrade Oracle Database installations. In this scenario, you have upgraded the Oracle Database Appliance infrastructure and Oracle Grid Infrastructure to Oracle Database Appliance Patch Bundle 12.1.2.6, but you have not upgraded Oracle Database installations. This procedure describes how to upgrade Oracle Database 11g release 2 (11.2) databases.

The Oracle Database Appliance Patch Bundle upgrade for Oracle Database uses a new numbering sequence. The Oracle Database upgrade for Oracle Database Appliance Patch Bundle 11.1.2.9 is 11.2.0.4.161018.

Before you start this procedure, you must complete the following tasks:

- Completed running the Oracle Database Appliance 12.1.2.6 Patch Bundle for infrastructure and Oracle Grid Infrastructure.
- Configured at least one Oracle Database Appliance database home for release 11.2.0.4.161018.

You configure an Oracle Database home using Oracle Appliance Manager, either as part of your patch bundle update initially, or as a manual procedure using the command `oakcli create dbhome`. You can run multiple Oracle Database instances on one Oracle Database home, to save storage space and obtain greater ease of management, or you can run Oracle Database instances in individual Oracle Database homes, for greater flexibility.

You must always have an Oracle Database Appliance database home for the database release to which you want to upgrade. In a new 12.1.2.9 deployment, a new 11.2.0.4.161018 Oracle Database home is set up for you automatically. If you are updating from an earlier release, then you must create at least one 11.2.0.4.161018 Oracle Database home manually using `oakcli create dbhome`.

1. If necessary, download the 11.2.0.4.161018 RDBMS Clone Patch from My Oracle Support, and create an Oracle Database home on Node 0 for Oracle Database release 11.2.0.4.161018.

For example:

```
# /opt/oracle/oak/bin/oakcli create dbhome -version 11.2.0.4.161018
```

2. Run the command `oakcli show dbhomes`.

The output appears similar to the following example:

Oracle HomeName	Oracle Home Version	Oracle HomeLocation	Database Name	Database Type
OraDb11204_home1	11.2.0.4.7(20760997,17592127)	/u01/app/oracle/product/11.2.0.4/dbhome_1	db1	RAC

3. Run the command `oakcli show databases` on Node 0 only. Review the output of this command to confirm that you have databases with the appropriate release number for this upgrade.

The following example shows that there is one database, `db1`, which is a database that is not an upgraded from release 11.2.0.4, and that is patched to a level from which you can upgrade (11.2.0.4.7):

```
# oakcli show databases
```

Name	Type	Storage	HomeName	HomeLocation	Version
db1	RAC	ACFS	OraDb11204_home1	/u01/app/oracle/product/11.2.0.4/dbhome_1	11.2.0.4.7(20760997,17592127)

4. Upgrade databases by running the command `oakcli upgrade database` on Node 0.

Run the command on Node 0 only. Provide names of databases that you want to upgrade, and provide names of database homes where you want the upgraded databases placed. Run the command with the following options, where `database` is the name of the database that you want to upgrade, and `dbhome` is the name of the Oracle home where you want the upgraded database to be placed:

```
oakcli upgrade database -db database -to dbhome
```

The following example shows how to upgrade the database `db1` identified in step 3 as an upgrade candidate, and how to place the upgraded database in the new database home, `OraDb12102_home2`, which is also identified in step 3:

```
# oakcli upgrade database -db db1 -to dbhome12102_home2.
```

5. After the upgrade command completes running, run the command `oakcli show databases` on Node 0 again.

The command and output should now look similar to the following example:

Name	Type	Storage	HomeName	HomeLocation	Version
db1	RAC	ACFS	OraDb12102_home2	/u01/app/oracle/product/12.1.0.2/dbhome_1	11.2.0.4.161018(24927502,24340679)

The database db1 is now in release 11.2.0.4, and the database home name is now OraDB12102_home2, which is in the path /u01/app/oracle/product/11.2.0.4/OraDb12102_home2.

3

Managing Storage

You can add storage to fully populate the base storage shelf and add a storage expansion shelf to your Oracle Database Appliance.

Topics:

- [About Managing Storage](#) (page 3-1)
You can add storage at any time without shutting down your databases or applications.
- [Preparing for a Storage Upgrade](#) (page 3-2)
Review and perform these best practices before adding storage to the base shelf or adding the expansion shelf.

3.1 About Managing Storage

You can add storage at any time without shutting down your databases or applications.

Oracle Database Appliance uses raw storage to protect data in the following ways:

- Flash or Fast Recovery Area (FRA) backup. Flash or fast recovery area is a storage area (directory on disk or Oracle ASM diskgroup) that contains redo logs, control file, archived logs, backup pieces and copies, and flashback logs.
- Mirroring. Double or triple mirroring provides protection against mechanical issues.

The amount of available storage is determined by the location of the FRA backup (external or internal) and if double or triple mirroring is used.

Oracle Database Appliance uses storage shelves, a base shelf and an optional storage expansion shelf. You can expand the base storage by adding a pack of solid-state drives (SSDs) to fully populate the base storage. You can further expand the storage by adding a second storage shelf. External NFS storage is supported for online backups, data staging, or additional database files.

 **Note:**

You must fully populate the base storage shelf before adding the expansion shelf.

When you add storage, Oracle Automatic Storage Management (Oracle ASM) automatically rebalances the data across all of the storage including the new drives. Rebalancing a disk group moves data between disks to ensure that every file is evenly spread across all of the disks in a disk group and all of the disks are evenly filled to the same percentage. Oracle ASM automatically initiates a rebalance after storage configuration changes, such as when you add disks.

About Expanding Storage

If you need additional storage after fully populating the base shelf, you can add a storage expansion shelf. The expansion shelf is hot-pluggable, enabling you to expand storage without database downtime. After cabling and powering up the expansion shelf, the system automatically configures Oracle ASM storage and data is automatically distributed to the new shelf.

 **Note:**

The process of rebalancing the data might impact performance until the new storage is correctly balanced across all drives. If possible, add a storage expansion shelf during a non-peak or non-production time period to minimize the performance impact of the automatic storage balancing.

The addition of the storage expansion shelf includes checks across both nodes. It is important to confirm that SSH does work across the nodes and all users can connect as expected using their shared password.

The following are the high level steps to expand storage:

1. Review the Oracle Database Appliance storage options.
2. Prepare for a storage upgrade by running checks to verify that the configuration is ready before adding storage to the base shelf or adding the expansion shelf.
3. Add storage if the base configuration is not full.
4. Add the storage expansion shelf, then log in to each server node and validate the cabling. After you confirm that the cabling is correct, power on the shelf and validate the storage.

 **Caution:**

Review cabling instructions carefully to ensure that you have carried out cabling correctly. Incorrect connections can cause data loss when adding a storage expansion shelf to Oracle Database Appliance with existing databases.

3.2 Preparing for a Storage Upgrade

Review and perform these best practices before adding storage to the base shelf or adding the expansion shelf.

1. Update Oracle Database Appliance to the latest Patch Bundle before expanding storage.
2. Confirm both nodes are at the same version and patch bundle level for software and firmware.

```
# oakcli show version -detail
```



```
#oakcli inventory -q
```



Note:

If oakd is not running on either node, fix the problem before adding storage.

3. Check the disk health of the existing storage disks.

Run the check on both nodes and use the default checks option to check the NetworkComponents, OSDiskStorage, SharedStorage, and SystemComponents.

```
# oakcli validate -d
```

4. Run the oakcli show diskgroup command on each node to display and review Oracle Automatic Storage Management (Oracle ASM) disk group information.

```
# oakcli show diskgroup data
```

```
# oakcli show diskgroup reco
```

```
# oakcli show diskgroup redo
```

5. Confirm Oracle ASM and CRS health on both nodes.

Run the oakcli orachk command on each node. If there is a problem connecting to either node, then check the /etc/bashrc file and remove (or remark out) any values in the profile for root ; oracle ; grid users

Run oakcli orachk on Node 0:

```
# oakcli orachk
...
```

```
Checking Status of Oracle Software Stack - Clusterware, ASM, RDBMS
```

```

.....
-----
Oracle Stack Status
-----
Host Name CRS Installed ASM HOME RDBMS Installed CRS UP ASM UP RDBMS UP DB Instance Name
-----
odax3rm1 Yes No Yes No No No .....
-----

```

```
...
```

Run oakcli orachk on Node 1:

```
# oakcli orachk
...
```

```
Checking Status of Oracle Software Stack - Clusterware, ASM, RDBMS
```

```

.....
-----
Oracle Stack Status
-----
Host Name CRS Installed ASM HOME RDBMS Installed CRS UP ASM UP RDBMS UP DB Instance Name
-----
odax3rm2 Yes Yes Yes Yes Yes Yes b22S2 b23S2 b24S2
-----

```

```
...
```

6. Confirm communications between the nodes and that SSH is working using the same password for oracle, root and grid.

From each node:

- a. ssh to both nodes.
 - b. Ping both nodes.
7. Confirm there is at least 10 GB of space available on each node.

```
[root@oda]# df -h
```

```
[root@odb]# df -h
```

4

Managing an Oracle Database Appliance Virtualized Platform

Review the concepts and procedures for Oracle Database Appliance Virtualized Platform.

These topics provides a conceptual overview of the Oracle Database Appliance Virtualized Platform architecture, and procedures for how to deploy a guest virtual machine, manage high availability, manage CPU pools, and configure network settings for Oracle Database Appliance Virtualized Platform. Learn about resizing your Oracle Database domain (ODA_BASE), a privileged virtual machine.

- [About Oracle Database Appliance Virtualized Platform](#) (page 4-2)
You can use Oracle VM to optimize your system resource use for databases and applications.
- [Oracle Database Appliance Virtualized Platform Architecture](#) (page 4-3)
Review these topics to understand Oracle Database Appliance Virtualized Platform, and how you can use it to optimize system resource use.
- [About Deploying an Oracle Database Appliance Virtualized Platform](#) (page 4-7)
To use the virtualization features, you must reimage the system and configure the appliance as a virtualized platform.
- [How to Create and Manage Shared Repositories](#) (page 4-9)
These topics describe how to use OAKCLI to create and manage shared repositories on Oracle Database Appliance Virtualized Platform.
- [How to Manage Virtual Disks in Shared Repositories](#) (page 4-12)
These topics describe how to use OAKCLI to create, view, clone, attach, and delete virtual disks on Oracle Database Appliance Virtualized Platform.
- [How to Manage Virtual Machine Templates](#) (page 4-15)
These topics describe how to use OAKCLI to import, configure, modify and check virtual machine templates on Oracle Database Appliance Virtualized Platform.
- [How to Create Clones and Snap Clones of a Template](#) (page 4-20)
Review these topics for an overview of clones and snap clones, and for procedures to use to create clones.
- [How to Manage Virtual Machines on Oracle Database Appliance Virtualized Platform](#) (page 4-23)
Review these topics for an overview of virtual machines, and for procedures to create and manage virtual machines.
- [How to Create Driver Domain Virtual Machines](#) (page 4-31)
Use driver domain virtual machines to improve performance.
- [How to Manage High Availability on Oracle Database Appliance Virtualized Platform](#) (page 4-41)
Use the `oakcli configure vm` command to configure high availability services for your virtual machines.

- [How to Manage CPU Pools on Oracle Database Appliance Virtualized Platform](#) (page 4-42)
These topics describe how to use OAKCLI to create and manage CPU pools on Oracle Database Appliance Virtualized Platform.
- [About Network Infrastructure and Virtual Local Area Networks on Oracle Database Appliance Virtualized Platform](#) (page 4-46)
To specify which network you want to use to access a virtual machine, you employ network infrastructure components of Oracle Database Appliance Virtualized Platform.
- [Managing Virtual Local Area Networks on User Domains and on ODA_BASE](#) (page 4-49)
Use these examples to understand how to configure and manage virtual local area networks (VLANs).
- [How to Resize ODA_BASE](#) (page 4-52)
You can increase or decrease the number of CPU cores that you assign the ODA_BASE domain to add or reduce computing power and memory as required for your workloads.

4.1 About Oracle Database Appliance Virtualized Platform

You can use Oracle VM to optimize your system resource use for databases and applications.

You can deploy a virtualized platform on Oracle Database Appliance. The virtual platform is based on Oracle VM. With Oracle Database Appliance Virtualized Platform, you can use the capabilities of Oracle VM to effectively allocate resources to databases and applications running on the same physical Oracle Database Appliance. Rather than simply disabling unnecessary server cores, you can use the excess capacity to host other workloads. This enables consolidation of both databases and applications, while retaining the ease of deployment and management associated with Oracle Database Appliance.

Oracle Database Appliance Virtualized Platform is supported on all versions of Oracle Database Appliance hardware. All templates and operating systems supported by Oracle VM are also supported on Oracle Database Appliance Virtualized Platform. Supported operating systems include Linux, Windows, and Solaris x86.



Note:

All new systems are currently shipped from the factory with the nonvirtualized ISO image

If you are currently on the nonvirtualized deployment of Oracle Database Appliance, and you want to use Oracle Database Appliance as a virtualized platform, then you must reimage the servers with the Oracle Database Appliance Virtualized Platform ISO image.

Why Virtualize?

Oracle Appliance Manager (oakcli) makes it easy to setup and manage the virtualized environment with little virtualization expertise. With the Virtualized Platform

deployment, you can consolidate entire multi-tier environments within a single Oracle Database Appliance system.

The following are some of the advantages of deploying Oracle Database Appliance with the Virtualized Platform option:

1. Deploy database and applications in a single hardware environment.
2. Use the pre-configured VM application templates to rapidly deploy database and applications.
3. Run the database in a virtual machine (ODA_BASE) with direct access to storage (for native performance).
4. Control licensed CPUs by configuring ODA_BASE domain with the required number of CPU cores (and memory).
5. Use your CPU cores (and memory) efficiently. CPU cores not assigned to the ODA_BASE domain are not wasted and are available for use by other, non-database virtual machines.
6. Use virtual local area networks (VLANs) to provide separate networks to different virtual machines.
7. Use shared repository to grow storage for the virtual machine (VM) repository.
8. Improves data center efficiency by increasing space utilization and reducing energy consumption and cooling costs.

4.2 Oracle Database Appliance Virtualized Platform Architecture

Review these topics to understand Oracle Database Appliance Virtualized Platform, and how you can use it to optimize system resource use.

- [About Oracle Database Appliance Virtualized Platform Architecture](#) (page 4-3)
Review this topic to understand how Oracle Database Appliance Virtualized Platform works with Oracle Database Appliance hardware.
- [About Virtual Machines and Oracle Database Appliance Virtualized Platforms](#) (page 4-4)
Oracle Database Appliance Virtualized Platform is designed to run and deploy virtual machines to manage system resources.

4.2.1 About Oracle Database Appliance Virtualized Platform Architecture

Review this topic to understand how Oracle Database Appliance Virtualized Platform works with Oracle Database Appliance hardware.

Oracle Database Appliance Virtualized Platform provides virtualization technology that enables multiple isolated databases and applications to share the same physical server. The Oracle Database Appliance Virtualized Platform ISO image is engineered specifically to leverage the Oracle Database Appliance hardware capabilities.

The Oracle Database Appliance Virtualized Platform architecture uses the virtual machine components shown in the following illustration:

Figure 4-1 Oracle Database Appliance Virtualized Platform Architecture

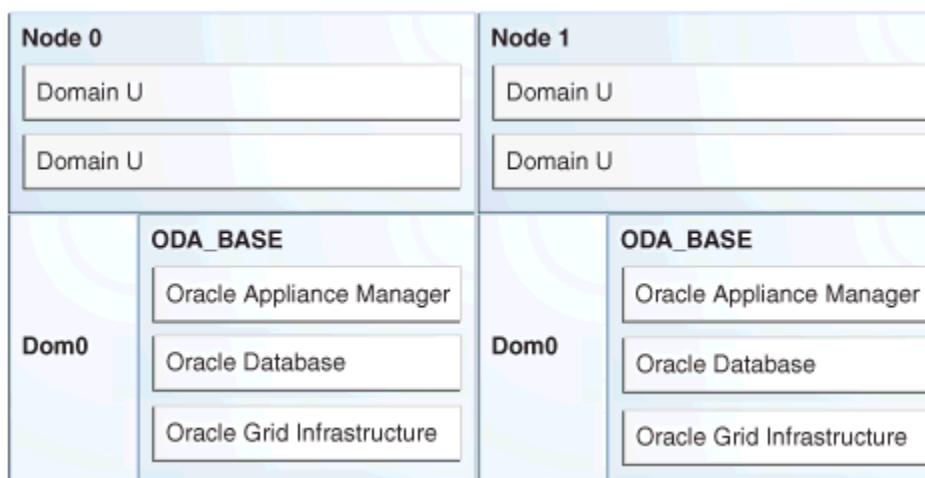

- **Oracle Database Appliance Base Domain (ODA_BASE):** A privileged virtual machine domain, specifically for databases, that provides database performance similar to bare metal deployments. A PCI pass-through driver provides ODA_BASE direct access to the shared storage.
- **Domain 0 (Dom0):** Default domain that initiates Oracle Database Appliance Virtualized Platform provisioning processes and hosts virtual machine templates. Most of the responsibility of hardware detection in an Oracle Database Appliance Virtualized Platform environment is passed to the management domain, referred to as domain zero (or Dom0). On x86-based servers, the Dom0 kernel is actually a small-footprint Linux kernel with support for a broad array of devices, file systems, and software RAID and volume management. In Oracle Database Appliance Virtualized Platform, Dom0 provides access to much of the system hardware, creating, deleting and controlling guest operating systems, and presenting those guests with a set of common virtual hardware.
- **Guest Domains (Domain U):** Virtual machines that are provisioned to host non-database workloads, such as applications and middleware. Guest operating systems each have their own management domain, called a *user domain*, abbreviated to "Domain U". These domains are unprivileged domains that have no direct access to the hardware or to the device drivers. Each Domain U starts after Dom0 is running on Oracle Database Appliance Virtualized Platform.

4.2.2 About Virtual Machines and Oracle Database Appliance Virtualized Platforms

Oracle Database Appliance Virtualized Platform is designed to run and deploy virtual machines to manage system resources.

Configure virtual machines on Oracle Database Appliance Virtualized Platform to manage your application use of shared repository resources, such as the CPU pool, memory, and other shared resources.

Virtual Machine Templates

Virtual machines can be created from a template or assembly containing preconfigured virtual machines. The creation of a virtual machine from a template is based on cloning: the template is imported as an archive, unpacked, and stored as a virtual machine configuration file with disk images. These disk images are cloned to create a new instance in the form of a virtual machine. In the same way, an existing virtual machine can be cloned to create a new virtual machine, or cloned to create a new template.

Virtual Machine Assemblies

Virtual machine assemblies are often described as a template of a group of virtual machines, or a collection of virtual machine templates. An assembly can contain a single virtual machine or a collection of virtual machine templates.

Domains, Guests and Virtual Machines

The terms *domain*, *guest*, and *virtual machine* are often used interchangeably, but they have subtle differences. A *domain* is a configurable set of resources, including memory, virtual CPUs, network devices, and disk devices, in which virtual machines run. A *guest* is a virtualized operating system running within a domain. Multiple guests can run on the same instance of Oracle Database Appliance Virtualized Platform, each within its own domain. A *virtual machine* is granted virtual resources, and can be started, stopped, and restarted independently.

Virtual Disks

In addition to virtual machines, you can create virtual disks in shared repositories. Virtual disks provide additional storage options for virtual machines by enabling you to attach additional block storage to your virtual machines. Similarly, you can detach the storage if you no longer need the additional space. You can use virtual disks to expand existing file system storage inside the virtual machine by extending the storage volume onto a virtual disk, or by creating a new file system on a virtual disk. Your virtual disks can also share multiple virtual machines running on the same shared repository.

A *driver domain* is a user domain that has special privileges and responsibilities for a particular piece of hardware. When you use the driver domain option, the newly created virtual disks are mounted directly from `ODA_BASE` to a guest virtual machine. The option improves performance by enabling guest virtual machines to use `ODA_BASE` instead of `Dom0` to access virtual disks. The driver domain option is available beginning with release 12.1.2.7.0 and is supported with Oracle Linux, Windows, and Oracle Solaris x86 guest operating systems. Live migration of driver domain virtual machines is not supported.

Shared Repositories

A *shared repository* is a central location for storing resources that are essential to creating and managing virtual machines. These resources include virtual machine templates and assemblies, ISO files (virtual DVD images), virtual machine configuration files, and virtual disks. Shared repositories are configured on an Oracle Automatic Storage Management Cluster File System (Oracle ACFS) and then presented to the Oracle Database Appliance nodes that need access to those resources. Oracle Database Appliance Virtualized Platform uses shared repositories to optimize available disk space usage in the environment, and for easy reallocation of

virtual machines if a physical server fails. The virtual machine files can be stored on shared disks, providing shared storage for the virtual machines. Additionally, you can configure CPU pools and a resizable Oracle Database domain (ODA_BASE) to ensure that the virtual machines do not consume cycles from each other or from your assigned database CPU cores.

- The shared disks on Oracle Database Appliance Virtualized Platform are connected directly to ODA_BASE.
- ODA_BASE contains three shared repositories named `fs1`, `fs2`, and `fs3`.
- Each shared repository is an Oracle ACFS in ODA_BASE created on top of the Oracle Automatic Storage Management (Oracle ASM) disk group (DATA or RECO) chosen by the user when creating the shared repository.
- The process that creates a shared repository also performs a network file system (NFS) export of the shared repository to the respective `Dom0` by using the private network.
- The export enables shared storage for the virtual machine files.

Figure 4-2 Architecture Overview of Oracle Database Appliance Virtualized Platform Shared Repositories

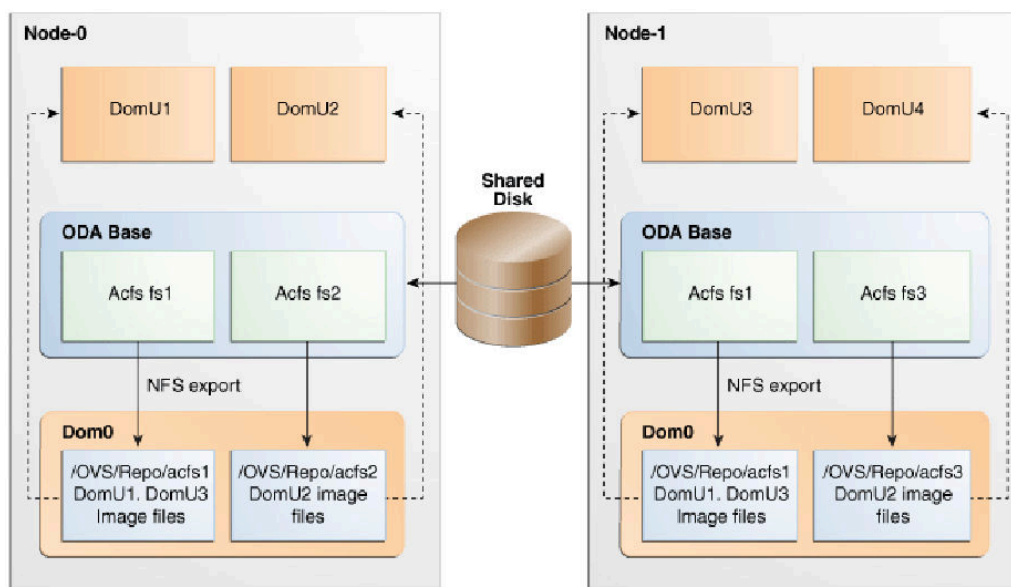

With the configuration shown in the illustration, you can:

- Create multiple repositories.
- Mount these repositories either on the nodes where the virtual machine needs to run (such as `fs2` and `fs3` in the illustration), or on both the nodes (such as `fs1` in the illustration).
- Create one or more virtual machines or virtual machine templates on the shared repositories.
- Use OAKCLI commands to create and manage shared repositories, virtual disks, and their virtual machines, and the underlying architecture shown in the illustration.

 **Note:**

Virtual machine (VM) repositories on Oracle Database Appliance can only be on the boot drives or an Oracle Database Appliance shared storage shelf. External storage cannot be used for VM shared repositories on Oracle Database Appliance.

4.3 About Deploying an Oracle Database Appliance Virtualized Platform

To use the virtualization features, you must reimage the system and configure the appliance as a virtualized platform.

Oracle Database Appliance ships from the factory with a bare metal ISO image installed. To enable virtualization, you must deploy the Virtualized OS ISO image on both nodes, configure your public network, and then deploy the Oracle Database Appliance Virtualization Platform. Oracle Database Appliance ships with various components, including Oracle Integrated Lights Out Manager (ILOM) to help manage the system remotely. The Oracle Integrated Lights Out Manager (ILOM) client must be on at least version `jre-7-linux-i586.rpm` to be able to launch the remote console.

Domain Deployment Configuration

Use the Oracle Appliance Kit Command-Line Interface, also known as OAKCLI, to deploy and configure the Oracle Database Appliance Virtualized Platform.

When you deploy Oracle Database Appliance Virtualized Platform, your system is configured with two domains on each server node: `Dom0` and `ODA_BASE` (also known as `Dom1`). You can use the CPU cores not assigned to Oracle Database (`ODA_BASE`) for virtual machines, each of which is referred to as a `Domain U`.

The virtual disk and `vm.cfg` files are stored in the following directories:

- `Dom0: /Repositories/vm_repo_name/.ACFS/snaps/vm_name/VirtualMachines/vm_name`
- `ODA_BASE: /app/sharedrepo/vm_repo_name/.ACFS/snaps/vm_name/VirtualMachines/vm_name`

Once deployed, you can create and manage shared repositories and create guest virtual machines and Oracle Linux driver domain guests.

Overview of Deploying a Virtualized Platform

The following is an overview of the steps to deploy a virtualized platform:

1. (Optional) Run the standalone Configurator to validate the network and create a configuration file. See “Running the Standalone Oracle Database Appliance Configurator”

While not required, using the standalone Configurator enables you to define your configuration details and validate the network on a separate system. You can save the settings in a configuration file and use the file to quickly pre-populate the configuration fields when you deploy the platform in Step 5.

2. Connect the power and public network cables and start up the systems.

3. Deploy the Virtualized OS ISO image to reimage the appliance operating system on both nodes and create an initial network.
4. Install the Virtualized Platform Template, then configure and deploy the appliance.

The template deploys ODA_BASE on your system, which includes the Oracle Database clone binaries, Oracle Database templates, customized for Oracle Database Appliance deployments, and Oracle Grid Infrastructure clone binaries. After you install the template, you will use the Configurator to define your configuration and network settings and install the appliance. After you successfully deploy the appliance, you can begin creating a virtual environment and virtual machines.

Overview of Deploying a Guest Virtual Machine

Deploying a Guest virtual machine requires the following steps:

1. Create a new repository, if necessary. See "How to Create and Manage Shared Repositories".
2. Import the required template or assembly. See "How to Manage Virtual Machine Templates".
3. Configure the template or assembly. See "Configuring a Virtual Machine Template".
4. Clone the template or assembly. See "How to Create Clones and Snap Clones of a Template".
5. Update the virtual machine as required. See "Modifying a Virtual Machine Template Configuration".
6. Start the virtual machine. See the `oakcli start` commands.
7. Manage the virtual machine using the virtual machine console. See the `oakcli show vmconsole` command.

A driver domain is a user domain with special privileges. The Driver Domain functionality allows guest virtual machines to use ODA_BASE as the driver domain for access to virtual disks. By default, the driver domain functionality applies to non-system disks. Once a virtual machine is created in driver domain mode, any new vDisks are added in driver domain mode.

When a user domain is configured in driver domain mode, the storage in the `vm.cfg` file at DomU might be similar to the following:

```
vm.cfg: disk = [u'file://OVS/Repositories/myreposeh1/.ACFS/snaps/v1_shared/
VirtualMachines/v1_shared/System.img,xvda,w', u'file:/u01/app/sharedrepo/
Repositories/myreposeh1/.ACFS/snaps/v1_shared/VirtualMachines/v1_shared/
u01.img,xvdb,w,oakDom1' ]
```

Note:

The second virtual disk is specified as a file on shared storage (in the shared repository) and it uses the ODA_BASE domain (`oakDom1`) as the driver domain.

4.4 How to Create and Manage Shared Repositories

These topics describe how to use OAKCLI to create and manage shared repositories on Oracle Database Appliance Virtualized Platform.

- [Creating a Shared Repository](#) (page 4-9)
Use the `oakcli create repo` command to create a shared repository on Oracle Database Appliance Virtualized Platforms.
- [Showing the Status of Shared Repositories](#) (page 4-10)
Use the `oakcli show repo` command to display information about virtual machine repositories on Oracle Database Appliance Virtualized Platforms.
- [Starting a Shared Repository](#) (page 4-10)
Use the `oakcli start repo` command to start a virtual machine and assign it to a shared repository on Oracle Database Appliance Virtualized Platforms.
- [Stopping a Shared Repository](#) (page 4-11)
Use the `oakcli stop repo` command to command to stop a shared repository on a node on Oracle Database Appliance Virtualized Platforms.
- [Deleting a Shared Repository](#) (page 4-11)
Use the `oakcli delete repo` command to delete a shared repository on Oracle Database Appliance Virtualized Platforms.
- [Increasing the Size of a Shared Repository](#) (page 4-12)
Use the `oakcli configure repo` command to increase the size of a shared repository on Oracle Database Appliance Virtualized Platforms.

4.4.1 Creating a Shared Repository

Use the `oakcli create repo` command to create a shared repository on Oracle Database Appliance Virtualized Platforms.

When you run the `oakcli create repo` command, you identify the repository name using the option `repo`, you identify the disk group that you want to use for its storage (DATA or RECO) using the option `-dg`, and you identify the size of the repository in gigabytes or megabytes (the default size unit is gigabytes) using the `-size` option.

Other Oracle Appliance Manager shared repository commands, including commands to show and to stop (dismount) existing repositories, are similar to those used for nonshared repositories. Unlike the default repositories, which are permanent, you can delete a shared repository that has no active (mounted) virtual machines.

Example of Creating a Shared Repository

The following command creates a shared repository named `repo1` in the ASM DATA disk group (`data`) with 30 gigabytes of available storage:

```
oakcli create repo repo1 -dg data -size 30
```

4.4.2 Showing the Status of Shared Repositories

Use the `oakcli show repo` command to display information about virtual machine repositories on Oracle Database Appliance Virtualized Platforms.

To see all repositories, omit the repository name and node number. To see a specific shared repository, include the repository name and node number.

Example 4-1 Example of Showing the Status of All Shared Repositories

To show the status of all shared repositories, use the `oakcli show repo` command:

```
oakcli show repo
NAME                TYPE          NODENUM  FREE SPACE  STATE
----                -
odarepo1            local         0         N/A         N/A
odarepo2            local         1         N/A         N/A
repo1                shared        0         68.25%      ONLINE
repo1                shared        1         68.25%      ONLINE
repo2                shared        0         N/A         OFFLINE
repo2                shared        1         89.83%      ONLINE
```

Example 4-2 Example of Showing the Status of a Selected Shared Repository

To display information for a particular node in a shared repository, specify the repository name and node number as part of the command syntax. In the following example, information is displayed for Node 1 in the `repo1` shared repository:

```
oakcli show repo repo1 -node 1

Resource: repo1_1
  AutoStart      : restore
  DG             : DATA
  Device         : /dev/asm/repo1-286
  ExpectedState  : Online
  FreeSpace      : 87.703125M
  MountPoint     : /u01/app/repo1
  Name           : repo1_0
  Node           : all
  RepoType       : shared
  Size           : 30720
  State         : Online
  Version        : 2
```

4.4.3 Starting a Shared Repository

Use the `oakcli start repo` command to start a virtual machine and assign it to a shared repository on Oracle Database Appliance Virtualized Platforms

Before you can assign a virtual machine to a shared repository, use the `oakcli start repo` command to start the repository and make the storage available. Note that the `oakcli start repo` command will also start any virtual machines assigned to the repository that are defined to be automatically started.

You must have a repository already configured. Identify the repository that you start by using the option `repo name`, where `name` is the repository name. Identify the name of the node on which the repository is located by using the option `-node nodename`, where `nodename` is the name of the node on which the repository is located.

Example 4-3 Example of Starting a Shared Repository

This command starts the shared repository named `repo1` on Node 1:

```
oakcli start repo repo1 -node 1
```

4.4.4 Stopping a Shared Repository

Use the `oakcli stop repo` command to command to stop a shared repository on a node on Oracle Database Appliance Virtualized Platforms.

Identify the repository that you want to stop by using the `repo reponame` option, where `reponame` identifies the repository that you want to stop. Identify the node on which the repository that you want to stop is running by using the `-node number` option where `number` is the node number that you want to stop.

Note:

Do not issue an `oakcli stop repo` command while virtual machines are still active in the repository for the selected node.

Example 4-4 Example of Stopping a Shared Repository

The following example stops the shared repository named `repo1` on Node 0:

```
oakcli stop repo repo1 -node 0
```

4.4.5 Deleting a Shared Repository

Use the `oakcli delete repo` command to delete a shared repository on Oracle Database Appliance Virtualized Platforms.

Identify the repository that you want to delete by using the `repo reponame` option, where `reponame` identifies the repository that you want to delete.

Note:

The shared repository that you want to delete must be offline (stopped) on both nodes before you attempt to delete it.

Example 4-5 Example of Deleting a Shared Repository

The following command deletes the shared repository named `repo1` on both nodes:

```
oakcli delete repo repo1
```

4.4.6 Increasing the Size of a Shared Repository

Use the `oakcli configure repo` command to increase the size of a shared repository on Oracle Database Appliance Virtualized Platforms.

Identify the repository that you want to expand by using the `-repo reponame` option, where `reponame` identifies the repository that you want to expand. Use the option `-incsize size` to specify the size of the increase that you want to configure, where `size` is the size (in gigabytes) that you want to add to the configured size.

Example 4-6 Example of Increasing the Size of a Shared Repository

The following command increases the size of the shared repository `rep01` by 2 gigabytes:

```
# oakcli configure repo rep01 -incsize 2G
```

```
Configured Shared Repo : rep01 with new size 3712.0.
```

4.5 How to Manage Virtual Disks in Shared Repositories

These topics describe how to use OAKCLI to create, view, clone, attach, and delete virtual disks on Oracle Database Appliance Virtualized Platform.

- [Creating a Virtual Disk for Use in a Shared Repository](#) (page 4-12)
Use the command `oakcli create vdisk` to create a virtual disk within a shared repository on Oracle Database Appliance Virtualized Platforms.
- [Viewing Information About Virtual Disks](#) (page 4-13)
Use the command `oakcli show vdisk` to view information about virtual disks on Oracle Database Appliance Virtualized Platforms.
- [Cloning Virtual Disks](#) (page 4-13)
Use the `oakcli clone vdisk` command to create clones of virtual disks on Oracle Database Appliance Virtualized Platforms.
- [Attaching a Virtual Disk to a Virtual Machine](#) (page 4-14)
Use the `oakcli modify vm` command to attach a virtual disk to a virtual machine on Oracle Database Appliance Virtualized Platforms.
- [Deleting a Virtual Disk](#) (page 4-14)
Use the `oakcli delete vdisk` command to remove a virtual disk from a shared repository on Oracle Database Appliance Virtualized Platforms.

4.5.1 Creating a Virtual Disk for Use in a Shared Repository

Use the command `oakcli create vdisk` to create a virtual disk within a shared repository on Oracle Database Appliance Virtualized Platforms.

The command `oakcli create vdisk` defines the size of the virtual disk, the shared repository in which that disk is created, defines the unique name for that disk within that shared repository, and defines if the disk is used for one virtual machine, or can be shared by multiple virtual machines.

The name of the vdisk you create is defined by the command `oakcli create vdisk name`, where `name` is the name of the vdisk you create. Identify the repository in which you create the vdisk by using the `-repo reponame` option, where `reponame` identifies the

repository where you want to create the vdisk. Use the option `-size sizeG` to specify the vdisk size (in gigabytes), where `sizeG` is the size (in gigabytes) that you want to add to the configured size. If you want to configure the vdisk as a shared disk, then use the option `-type shared` to designate the vdisk as a shared disk.

Example 4-7 Example of Creating a Shared Virtual Disk

This example creates a virtual disk named `sdisk1` in the `repo2` shared repository that is 1 gigabyte in size, and that virtual machines can share:

```
oakcli create vdisk sdisk1 -repo repo2 -size 1G -type shared
```

4.5.2 Viewing Information About Virtual Disks

Use the command `oakcli show vdisk` to view information about virtual disks on Oracle Database Appliance Virtualized Platforms.

You can use `oakcli show vdisk` by itself to see information about all of your configured virtual disks. To see information about an individual virtual disk, enter the command `oakcli show vdisk diskname -repo reponame`, where `diskname` is the name of the disk that you want to check, and `reponame` is the name of the shared repository where the virtual disk is located.

Example 4-8 Example of Displaying the Information for All Vdisks

This example displays information about all virtual disks configured on an Oracle Database Appliance:

```
# oakcli show vdisk
```

NAME	SIZE	TYPE	REPOSITORY
----	----	----	-----
myvdisk	10G	local	vdiskrepo
newv	1G	local	vdiskrepo

Example 4-9 Example of Displaying Information for a Single Vdisk

This example displays information for the virtual disk named `myvdisk1`:

```
# oakcli show vdisk myvdisk1
Resource: myvdisk_vdiskrepo
Name      : myvdisk_vdiskrepo
RepoName  : vdiskrepo
Size      : 10G
Type      : local
VmAttached : 0
```

4.5.3 Cloning Virtual Disks

Use the `oakcli clone vdisk` command to create clones of virtual disks on Oracle Database Appliance Virtualized Platforms.

The command `oakcli clone vdisk` defines the size of the virtual disk, the shared repository in which that disk is created, defines the unique name for that disk within that shared repository, and defines if the disk is used for one virtual machine, or can be shared by multiple virtual machines.

The name of the vdisk you create is defined by the command `oakcli clone vdisk name`, where `name` is the name of the vdisk you create. Identify the repository in which you

create the vdisk by using the `-repo reponame` option, where *reponame* is the name of the repository where the original vdisk is located. Use the option `-src sourcevdiskname`, where *sourcevdiskname* is the name of the virtual disk that you are cloning. Add the option `-h` to display help for this command.

**Note:**

Once the virtual disk is attached to a virtual machine, the system administrator should perform normal disk addition tasks for the given operating system to make the newly added storage available to the virtual machine.

Syntax

```
oakcli clone vdisk name -repo reponame -src sourcevdiskname [-h]
```

Example 4-10 Example of Cloning a Virtual Disk

This example clones a virtual disk named `my_vdisk2` from an existing virtual disk named `vdisk1` that is stored in the repository named `vrepo1`:

```
oakcli clone vdisk my_vdisk2 -repo vrepo1 -src vdisk1
```

4.5.4 Attaching a Virtual Disk to a Virtual Machine

Use the `oakcli modify vm` command to attach a virtual disk to a virtual machine on Oracle Database Appliance Virtualized Platforms.

The command `oakcli modify vm name` enables you to modify a virtual machine, where *name* is the name of the virtual machine that you want to modify. To attach a disk to a virtual machine, use the option `-attachvdisk vdiskname`, where *vdiskname* is the name of the virtual disk that you want to attach to the virtual machine.

Example 4-11 Example of Attaching a Virtual Disk To a Virtual Machine

This example attaches the virtual disk named `sdisk1` to the virtual machine named `myol6u_test`:

```
oakcli modify vm myol6u_test -attachvdisk sdisk1
```

4.5.5 Deleting a Virtual Disk

Use the `oakcli delete vdisk` command to remove a virtual disk from a shared repository on Oracle Database Appliance Virtualized Platforms.

The command `oakcli delete vdisk vdiskname` removes a virtual disk, where *vdiskname* is the name of the virtual disk that you want to remove. The option `-repo reponame` indicates the shared repository on which the virtual disk is located, where *reponame* is the name of the shared repository.

Example 4-12 Example of Deleting a Virtual Disk from a Shared Repository

This example removes a virtual disk named `t2g` from the shared repository named `repoprod1`:

```
oakcli delete vdisk t2g -repo repoprod1
```

4.6 How to Manage Virtual Machine Templates

These topics describe how to use OAKCLI to import, configure, modify and check virtual machine templates on Oracle Database Appliance Virtualized Platform.

- [About Managing Virtual Machine Templates](#) (page 4-15)
Import and configure virtual machine templates as the source for the virtual machines deployed on Oracle Database Appliance Virtualized Platform.
- [Listing Virtual Machine Templates](#) (page 4-16)
Use the `oakcli show vmtemplate` command to display virtual machine template details.
- [Importing Virtual Machine Templates](#) (page 4-17)
Use the `oakcli import vmtemplate` command to import virtual machine templates and assemblies on Oracle Database Appliance Virtualized Platforms.
- [Configuring a Virtual Machine Template](#) (page 4-18)
Use the `oakcli configure vmtemplate` command to configure a virtual machine template on Oracle Database Appliance Virtualized Platform.
- [Showing Configured Values for a Virtual Machine Template](#) (page 4-19)
Use the `oakcli show vmtemplate` command to show values for the configurable options in a virtual machine template.
- [Modifying a Virtual Machine Template Configuration](#) (page 4-19)
Use the `oakcli modify vmtemplate` command to modify a virtual machine template.
- [Removing a Virtual Machine Template](#) (page 4-20)
Use the `oakcli delete vmtemplate` command to remove a virtual machine template.

4.6.1 About Managing Virtual Machine Templates

Import and configure virtual machine templates as the source for the virtual machines deployed on Oracle Database Appliance Virtualized Platform.

If you have created shared repositories, then import templates into one of those shared repositories. If you have not created shared repositories, then import templates into the local repository on one of the local nodes.

You can import assemblies that contain one or more templates. When you import a template or assembly into a shared repository, select a node that you want to perform the operation. Select the node carefully to avoid overloading the node. After you create the repository, the repository becomes available to both nodes, regardless of which node performs the import.

Templates imported into local nodes use the repository name supplied in the import command to identify the node that completes the import, and that provides the storage. On Node 0, the local repository is named `odarepo1` and on Node 1, the local repository is named `odarepo2`. If you want to import a template to both local repositories, then you must provide a different template name when you import the template into the second node.

 **Note:**

You cannot create or clone templates directly on Oracle Database Appliance Virtualized Platform, you must use the Oracle VM templates that are available in Oracle Software Delivery.

If you import an assembly that contains more than one template, then the command automatically modifies the template name that you provide, so that all template names remain unique. The first template you import has the number "1" appended to the name. The second template as the number "2" appended, and additional templates have 3, 4, 5 and so on appended in sequence.

After you import a virtual machine template, you can customize the template using OAKCLI commands.

 **Note:**

Find virtual machine templates at the following URL:

<http://edelivery.oracle.com/linux>.

4.6.2 Listing Virtual Machine Templates

Use the `oakcli show vmtemplate` command to display virtual machine template details.

The `oakcli show vmtemplate` command displays the name and repository for each virtual machine template as well as the default number of CPUs and default amount of memory that Oracle Database Appliance Virtualized Platform would assign to a virtual machine created from the template.

Example

Display information about the `sample1_odarepol` virtual template:

```
oakcli show vmtemplate sample_odarepol
Resource: sample1_odarepol
  CPUPriority      :      100
  Disks            :      |file:/OVS/Repositories/odarepol/Te
                    |mplates/otml_sample1_odarepol/Syste
                    |m.img,xvda,w||file:/OVS/Repositorie
                    |s/odarepol/Templates/otml_sample1_o
                    |darepol/u01.img,xvdb,w|
  Domain          :      XEN_PVM
  Keyboard        :      en-us
  MaxMemory       :      2048
  MaxVcpu         :      2
  Memory          :      2048
  Mouse           :      OS_DEFAULT
  Name            :      sample1_odarepol
  Networks        :      |bridge=priv1||bridge=net1||bridge=
                    |net2|
  NodeNum        :      0
  OS              :      OL_5
```

```
ProcessorCap    :    100
RepoName       :    odarepo1
Vcpu           :     2
```

4.6.3 Importing Virtual Machine Templates

Use the `oakcli import vmtemplate` command to import virtual machine templates and assemblies on Oracle Database Appliance Virtualized Platforms.

You import virtual machine templates and assemblies contained in an external repository assembly file. Use the name of the shared repository and include a clause to identify the node where you want to import a template or an assembly.

You can import virtual machine templates and assemblies directly from a remote repository using a URL to identify the source of the files. You can choose to use a remote copy command to copy files from the remote repository into your `Dom0 /OVS` directory, and then import the files using the path and names to identify the downloaded files.

Note:

When importing templates or assemblies to a local repository, do not use the `-node` option. The target node is implicit in the name of the repository.

Syntax

```
oakcli import vmtemplate vmtemplatename -files image_files | -assembly assembly_file
-repo repo_name [- node 0 | 1 ]
```

Example 4-13 Example of Importing Virtual Machine Templates from an External Repository Assembly File

Use the `oakcli import vmtemplate vmtemplatename -assembly assembly_file -repo repo_name` command to import virtual machine templates contained in an external template repository assembly file.

This example imports the template in an external template repository assembly file located at the URL `'http://example.com/assemblies/OEL6/OVM_OL6U1_x86_PVHVM.ova'` to a new template named `OL6U1` in a new repository named `odarepo1`:

```
oakcli import vmtemplate OL6U1 -assembly 'http://example.com/assemblies/OEL6/
OVM_OL6U1_x86_PVHVM.ova' -repo odarepo1
```

Note the single quotation marks that enclose the URL.

Example 4-14 Example of Importing a Virtual Machine Template from Dom0

Use this command syntax to import a virtual machine template from the `/OVS` file system on `Dom0`:

```
oakcli import vmtemplate vmtemplatename -files image_files -repo repo_name
```

This example imports the virtual machine template named `OVM_OL5U7_x86_64_PVM_10GB.tgz` from the `/OVS` directory in `Dom0` into the `odarepo1` repository. The template is assigned the name `OL5U7`:

```
oakcli import vmtemplate OL5U7 -files /OVS/OVM_OL5U7_x86_64_PVM_10GB.tgz -repo odarepol
```

Example 4-15 Example of Importing a Virtual Machine Template Using an External Repository URL

Use the command `oakcli import vmtemplate vmtemplatename -files image_files -repo repo_name` to import a virtual machine template file from an external template repository.

This example imports a virtual machine template named `OVM_OL5U7_x86_64_PVM_10GB.tgz` from an external template repository at the URL `'http://example.com/assemblies/OEL6/OVM_OL6U1_x86_PVHVM.tgz'`. Note the single quotation marks that enclose the URL. The template is assigned the name `OL5U7`, and is imported into the `odarepol` repository:

```
oakcli import vmtemplate OL5U7 -files 'http://example.com/assemblies/OEL6/OVM_OL6U1_x86_PVHVM.tgz'-repo odarepol
```

4.6.4 Configuring a Virtual Machine Template

Use the `oakcli configure vmtemplate` command to configure a virtual machine template on Oracle Database Appliance Virtualized Platform.

The values become the default values for any virtual machine cloned from this template. You can change any or all of them later with the `oakcli configure vm` command.

Example

Set values for the virtual machine template named `myol5u7_10gb`:

```
oakcli configure vmtemplate myol5u7_10gb -vcpu 2 -maxvcpu 4 -cpucap 40 -memory 1536M -maxmemory 2G -os OTHER_LINUX
```

- `-vcpu 2` sets the number of CPUs to be assigned when the virtual machine starts up to 2.
- `-maxvcpu 4` sets the maximum number of CPUs that can be assigned to the virtual machine to 4.
- `-cpucap 40` sets the maximum percentage of a CPU's capacity that can be assigned to the virtual machine to 40%.
- `-memory 1536M` sets the amount of memory to be assigned when the virtual machine starts up to 1536 MB.
- `-maxmemory 2G` sets the maximum amount of memory that can be assigned to the virtual machine to 2 GB.
- `-os OTHER_LINUX` sets `OTHER_LINUX` as the operating system used by the virtual machine.

4.6.5 Showing Configured Values for a Virtual Machine Template

Use the `oakcli show vmtemplate` command to show values for the configurable options in a virtual machine template.

Example

Display information about the `sample1_odarepol` virtual template:

```
oakcli show vmtemplate sample_odarepol
Resource: sample1_odarepol
      CPUPriority      :      100
      Disks            :      |file:/OVS/Repositories/odarepol/Te
                          mplates/otml_sample1_odarepol/Syste
                          m.img,xvda,w|file:/OVS/Repositorie
                          s/odarepol/Templates/otml_sample1_o
                          darepol/u01.img,xvdb,w|
      Domain          :      XEN_PVM
      Keyboard        :      en-us
      MaxMemory       :      2048
      MaxVcpu         :      2
      Memory          :      2048
      Mouse           :      OS_DEFAULT
      Name            :      sample1_odarepol
      Networks        :      |bridge=priv1||bridge=net1||bridge=
                          net2|
      NodeNum         :      0
      OS              :      OL_5
      ProcessorCap    :      100
      RepoName        :      odarepol
      Vcpu            :      2
```

4.6.6 Modifying a Virtual Machine Template Configuration

Use the `oakcli modify vmtemplate` command to modify a virtual machine template.

After you import a virtual machine template to a storage repository, examine the template configuration parameters with the `oakcli show vmtemplate` command. If you need to reconfigure the template for specific requirements, then use the `oakcli configure vmtemplate` command. This is useful if you plan to deploy multiple virtual machines with the same characteristics from a single template. If you will be deploying only one virtual machine or many virtual machines but with different characteristics, then set required values in the virtual machines with the `oakcli configure vm` command after you deploy the template.

When you are satisfied with the configuration of your virtual machine template, use the `oakcli modify` command to assign a new network to the virtual machine template.

Example

Replace the network assigned to the `gc_11g` virtual machine template with the `net1` network:

```
oakcli modify vmtemplate gc_11g -addnetwork net1
```

4.6.7 Removing a Virtual Machine Template

Use the `oakcli delete vmtemplate` command to remove a virtual machine template.

If you no longer need a template that you previously stored, then you can remove the template from the repository.

Example

Remove the virtual machine template named `myo16u_15gb3` from Oracle Database Appliance Virtualized Platform:

```
oakcli delete vmtemplate myo16u_15gb3
```

4.7 How to Create Clones and Snap Clones of a Template

Review these topics for an overview of clones and snap clones, and for procedures to use to create clones.

- [About Creating Clones and Snap Clones of a Template](#) (page 4-20)
You can create, or *clone*, virtual machines from imported templates (or assemblies) or from an existing virtual machine on Oracle Database Appliance Virtualized Platforms.
- [Cloning a Template With OAKCLI](#) (page 4-21)
Use the `oakcli clone vm` command to clone virtual machines that have attached virtual disks on Oracle Database Appliance Virtualized Platforms.
- [Creating a Snap Clone from a Template With OAKCLI](#) (page 4-21)
Use the `oakcli clone vm` command to create a snap clone of a virtual machine template on Oracle Database Appliance Virtualized Platforms.
- [Creating a Snap Clone of an Existing Virtual Machine With OAKCLI](#) (page 4-22)
Use the `oakcli clone vm` command to create a snap clone of an existing virtual machine on Oracle Database Appliance Virtualized Platforms.
- [Creating a Snap Clone of an Existing Virtual Machine That Uses a Different Domain](#) (page 4-22)
Use the `oakcli clone vm` command and options to create a virtual machine that uses a different domain than the source virtual machine on Oracle Database Appliance Virtualized Platforms.

4.7.1 About Creating Clones and Snap Clones of a Template

You can create, or *clone*, virtual machines from imported templates (or assemblies) or from an existing virtual machine on Oracle Database Appliance Virtualized Platforms.

Clones and snap clones can be an effective way to provision and clone new databases for test and development systems. They are much more efficient to create than using RMAN scripts, or other cloning approaches.

You can create virtual machines that are a complete clone of the template or assembly, or you can create virtual machines that are snap clones. Snap clones contain only the metadata defined for the virtual machine.

Creating snap clones is a very fast operation compared to cloning the entire template or assembly. However, if you update the contents of a snap clone, then review your

space requirements. Unless your changes to the snap clone are carried out on shared virtual disks, you require additional storage on your system for the clone to retain both the original content, as well as changed content.

4.7.2 Cloning a Template With OAKCLI

Use the `oakcli clone vm` command to clone virtual machines that have attached virtual disks on Oracle Database Appliance Virtualized Platforms.

When you clone virtual machines with attached virtual disks, a clone of a virtual machine contains the contents of virtual disks attached locally, but does not contain contents of virtual disks attached in shared mode. If needed, you can clone the virtual disks required by a cloned virtual machine in a separate step.

Use the command `oakcli clone vm` to create a virtual machine from a virtual machine template. Use the `-repo name` option to provide the name of the shared repository, where *name* is the name of the repository. Use the `-node number` option to identify the node on which you want to perform the cloning process, where *number* is the number of the node.

Note:

The `-node` option identifies the node where the cloning activity is carried out. The node value does not assign the default startup node for the virtual machine. You can set the startup assignment with the command `oakcli configure vm`.

Example 4-16 Example of Creating a Virtual Machine Clone from a Virtual Machine Template

This example creates a virtual machine named `myo16u_test` from the virtual machine template named `myo16u_15gb1`, which is located in a shared repository named `repo2` on Node 0:

```
oakcli clone vm myo16u_test -vmtemplate myo16u_15gb1 -repo repo2 -node 0
```

4.7.3 Creating a Snap Clone from a Template With OAKCLI

Use the `oakcli clone vm` command to create a snap clone of a virtual machine template on Oracle Database Appliance Virtualized Platforms.

Use the `-vmtemplate name` option to provide the name of the virtual machine template that you want to clone, where *name* is the name of the template. Use the `-snap` option to designate that you want to create a snap clone.

Example 4-17 Example of Creating a Snap Clone From a Virtual Machine Template

This example creates a snap clone named `myo115u_snap` from the virtual machine template named `myo15u`:

```
oakcli clone vm myo115u_snap -vmtemplate myo15u -snap
```

4.7.4 Creating a Snap Clone of an Existing Virtual Machine With OAKCLI

Use the `oakcli clone vm` command to create a snap clone of an existing virtual machine on Oracle Database Appliance Virtualized Platforms.

Use the `-vm name` option to provide the name of the virtual machine that you want to clone, where `name` is the name of the virtual machine. Use the `-snap` option to designate that you want to create a snap clone.

Example 4-18 Example of Creating a Snap Clone From an Existing Virtual Machine

This example creates a snap clone named `myol15u_test1` from a virtual machine named `myol15u_test`:

```
oakcli clone vm myol15u_test1 -vm myol15u_test1 -snap
```

4.7.5 Creating a Snap Clone of an Existing Virtual Machine That Uses a Different Domain

Use the `oakcli clone vm` command and options to create a virtual machine that uses a different domain than the source virtual machine on Oracle Database Appliance Virtualized Platforms.

Whether or not the source virtual machine is using a driver domain, you can use the `oakcli clone vm` command and options to specify the type of domain for the cloned virtual machine.

When the source virtual machine is not in driver domain mode, use the `-snap` option to designate that you want to create a snapshot of the source virtual machine and the `-force` and `-driverdomain` options to indicate that the new virtual machine will use the driver domain. Use the `-vm name` option to provide the name of the virtual machine and use `-vmsource virtual machine name` to identify the source virtual machine.

```
oakcli clone vm vm_name -vm src_vm_name -snap -force -driverdomain
```

When the source virtual machine is in driver domain mode, you can clone a virtual machine that does not use the driver domain option. If you want to create a new virtual machine that does not use the domain mode, use the `oakcli clone vm` without specifying the `-driverdomain` option.

```
oakcli clone vm <vm_name> -vm <src_vm_name> -snap [-force]
```



Note:

You must stop the virtual machine before taking the snapshot.

Example of Creating a Virtual Machine in Driver Domain Mode When the Source is not in Driver Domain Mode

The following command creates a virtual machine named `my_vm_1` from the source virtual machine named `my_source_vm`. The source virtual machine is not in driver domain mode, the new virtual machine is in driver domain mode:

```
oakcli clone vm my_vm_1 -vm my_source_vm -snap [-force] [-driverdomain]
```

Example of Creating a Virtual Machine That is Not in Driver Domain Mode When the Source is in Driver Domain Mode

When a virtual machine has the driver domain functionality enabled, you can clone a guest virtual machine that does not use the driver domain option. In this example, the source virtual machine, `my_source_vm`, is in driver domain mode. If you want to create a guest virtual machine that does not use the domain mode, use the `oakcli clone vm` without specifying the `-driverdomain` option.

The following command creates a virtual machine named `my_vm_2` that is using the source virtual machine named `my_source_vm`:

```
oakcli clone vm my_vm_2 -vm my_source_vm -snap [-force]
```

4.8 How to Manage Virtual Machines on Oracle Database Appliance Virtualized Platform

Review these topics for an overview of virtual machines, and for procedures to create and manage virtual machines.

- [About Managing Virtual Machines on Oracle Database Appliance Virtualized Platform](#) (page 4-24)
Deploy virtual machines on Oracle Database Appliance Virtualized Platform to run other workloads that are independent of databases running in ODA_BASE
- [Listing the Virtual Machines in Your Repositories](#) (page 4-25)
Use the `oakcli show vm` command to display details for all of your existing virtual machines or to display details of a specific virtual machine.
- [Creating a Virtual Machine](#) (page 4-26)
Create a virtual machine by cloning an imported template, cloning an assembly that contains configured virtual machines, or cloning an existing virtual machine.
- [Configuring a Virtual Machine](#) (page 4-26)
Use the `oakcli configure vm` command to configure a virtual machine on Oracle Database Appliance Virtualized Platform.
- [Starting and Stopping a Virtual Machine](#) (page 4-28)
Use the `oakcli start vm` command to start a virtual machine on Oracle Database Appliance Virtualized Platform and use the `oakcli stop vm` command to stop a virtual machine.
- [Externally Configuring a Virtual Machine](#) (page 4-28)
You can initially configure your virtual machines externally without connecting to the virtual machine console by using Oracle VM Guest Additions by passing key-value pairs to the virtual machine.

- [Opening a Virtual Machine Console for a Virtual Machine](#) (page 4-28)
Use the `oakcli show vmconsole` command to open a virtual machine console window for an active virtual machine
- [Creating an Image for a New Virtual Machine](#) (page 4-29)
Use the `oakcli clone vm` command to create an image for a new virtual machine on Oracle Database Appliance Virtualized Platform.
- [Setting Up a Virtual Machine for Access from eth0 Using an IP Address](#) (page 4-29)
Configure a network device (`eth0`) with an IP address for a virtual machine.
- [Adding or Removing a Virtual Disk to or from a Virtual Machine](#) (page 4-29)
Use the `oakcli modify vm` command to add or remove a virtual disk (`vdisk`) from a virtual machine.
- [Removing a Virtual Machine from a Shared Repository](#) (page 4-30)
Use the `oakcli delete vm` command to delete the virtual machine and reclaim its storage and resources.
- [Performing a Live Migration for an Oracle Database Appliance Virtual Machine](#) (page 4-30)
If your system meets requirements for live migration, then you can use the `oakcli migrate vm` command to migrate a virtual machine from the currently running node to another node.

4.8.1 About Managing Virtual Machines on Oracle Database Appliance Virtualized Platform

Deploy virtual machines on Oracle Database Appliance Virtualized Platform to run other workloads that are independent of databases running in ODA_BASE

Use OAKCLI commands to create and manage virtual machines, including starting and stopping them, and opening consoles for graphical user interface (GUI) access.



Note:

You can use a Virtual Network Computing (VNC) session to open a GUI console for a virtual machine.

You can reconfigure an active virtual machine. However, your changes do not take effect until you stop and restart the virtual machine. You can display high-level information about all of your virtual machines, or display detailed information about the configuration of single virtual machines. When you no longer have use for a particular virtual machine, delete the virtual machine to regain storage.

 **Note:**

Do not modify the default settings for the following parameters in the guest virtual machine:

- `xen_blkfront.max`: Max Indirect Descriptors, default 32
- `xen_blkback.max_ring_page_order`: Shared Ring Page Order, default 0

4.8.2 Listing the Virtual Machines in Your Repositories

Use the `oakcli show vm` command to display details for all of your existing virtual machines or to display details of a specific virtual machine.

The command displays the name, the repository, and the current state (online or offline) for each virtual machine. The output also contains the default number of CPUs and default amount of memory that Oracle Database Appliance Virtualized Platform will assign to each virtual machine.

- Use the `oakcli show vm` command to display the virtual machine names, memory and vCPU allocations, status, virtual disks, and repository name for all virtual machines.

```
oakcli show vm
```

NAME	MEMORY	VCPU	STATE	REPOSITORY
----	-----	----	-----	-----
sample5_odarepo1 odarepo1	2048	2	OFFLINE	
sample6_odarepo1 odarepo2	2048	2	OFFLINE	
test1_odarepo1 odarepo1	2048	2	OFFLINE	
test2_odarepo2 odarepo2	2048	2	OFFLINE	
vm1_odarepo1 odarepo1	4096	4	ONLINE	
vm2_odarepo2 odarepo2	2048	2	OFFLINE	
win_vm1	1500	1	ONLINE	odarepo1

- Use the `oakcli show vm virtual machine name` command to display information about a specific virtual machine.

For example, use the following command to display details about the `vm1_odarepo1` virtual machine:

```
oakcli show vm vm1_odarepo1
Resource: vm1_odarepo1
  AutoStart      :      restore
  CPUPriority    :      100
  Disks          :      |file:/OVS/Repositories/odarepo1/Vi
                    rtualMachines/vm1_odarepo1/System.i
                    mg,xvda,w||file:/OVS/Repositories/o
                    darepo1/VirtualMachines/vm1_odarepo
                    1/u01.img,xvdb,w|
  Domain        :      XEN_PVM
  ExpectedState  :      online
```

```

FailOver      : false
IsSharedRepo  : false
Keyboard      : en-us
MaxMemory     : 3000
MaxVcpu       : 4
Memory        : 4096
Mouse         : OS_DEFAULT
Name          : vm1_odarepo1
Networks      : |mac=00:21:F6:00:00:E4|
NodeNum       : 0
NodeNumStart  :
OS            : OL_5
PrivateIP     : None
ProcessorCap  : 100
RepoName      : odarepo1
State         : Online
TemplateName  : otml_sample1_odarepo1
Vcpu          : 4
cpupool       : twocpu
vncport       : 5901

```

4.8.3 Creating a Virtual Machine

Create a virtual machine by cloning an imported template, cloning an assembly that contains configured virtual machines, or cloning an existing virtual machine.

A virtual machine is a software emulation of a computer system that is granted virtual resources, and can be started, stopped, and restarted independently.

When you clone a template, the template is imported as an archive, unpacked, and stored as a virtual machine configuration file with disk images. The disk images are cloned to create a new instance in the form of a virtual machine.

Instead of creating a complete clone of a template or assembly, you can create a snap clone, which contains only the metadata defined for the virtual machine.

Related Topics

- [How to Create Clones and Snap Clones of a Template](#) (page 4-20)
Review these topics for an overview of clones and snap clones, and for procedures to use to create clones.

4.8.4 Configuring a Virtual Machine

Use the `oakcli configure vm` command to configure a virtual machine on Oracle Database Appliance Virtualized Platform.

Include a `-prefnode` clause, to identify the node where you want the virtual machine to run by default and a `-failover` clause to indicate if you want the virtual machine to use the other node when the preferred node is not available (either at startup or while already active).

If you reconfigure a virtual machine that is currently running, then your changes do not take effect until you stop and restart the virtual machine.

Table 4-1 Parameters Available for Configuring a Virtual Machine

Parameter	Description
-vcpu 2	Sets two (2) as the number of CPUs to be assigned to the virtual machine when started
-cpuprio 150	Sets the CPU access priority to 150
-cpucap 20	Sets the maximum percentage of a CPU's capacity that will be assigned to the virtual machine to 20%
-memory 1G	Sets the amount of memory assigned when the virtual machine starts to 1 GB
-cpupool linpool	Specifies linpool as the CPU pool to be assigned to the virtual machine
-keyboard en-us	Defines the keyboard type used to access the virtual machine as en-us
-mouse USB_MOUSE	Defines the mouse type used to access the virtual machine as a USB mouse

These values will override values assigned to these same parameters in the virtual machine template from which this virtual machine was derived. The virtual machine will use default values for parameters that are not defined in either the parent template or in a configuration command.

 **Note:**

CPU capacity is controlled by the CPU pool assigned to a virtual machine by either the `-cpupool` parameter or by the `default_unpinned_pool` (if the virtual machine is not configured with a `-cpupool` parameter). Values for `-vcpu` and `-maxvcpu` parameters that are larger than the number of CPUs in the assigned CPU pool are ignored.

Use the `oakcli configure` command and parameters to configure the virtual machine:

```
# oakcli modify vm vmname parameters
```

Example 4-19 Example of Configuring a Virtual Machine

Set values for specific resources in the virtual machine named `myo115u`:

```
oakcli configure vm myo15u
-vcpu 2 -cpuprio 150 -cpucap 20 -memory 1G
-cpupool linpool -keyboard en-us -mouse USB_MOUSE
```

Related Topics

- [oakcli configure vm](#) (page 5-17)
Use the `oakcli configure vm` command to configure a virtual machine on Oracle Database Appliance Virtualized Platform and to increase or decrease resource allocation to user domains.

4.8.5 Starting and Stopping a Virtual Machine

Use the `oakcli start vm` command to start a virtual machine on Oracle Database Appliance Virtualized Platform and use the `oakcli stop vm` command to stop a virtual machine.

Note:

If you reconfigure a virtual machine that is currently running, then your changes will not be effective until you stop and restart the virtual machine.

4.8.6 Externally Configuring a Virtual Machine

You can initially configure your virtual machines externally without connecting to the virtual machine console by using Oracle VM Guest Additions by passing key-value pairs to the virtual machine.

Use the `oakcli modify vm -s` command to pass parameters to the virtual machine:

```
# oakcli modify vm vmname -s 'key1:value1;key2:value2...'
```

The following example has two value pairs:

```
oakcli modify vm vml6u3 -s 'com.oracle.linux.network.device.  
0:eth0;com.oracle.linux.network.ipaddr.0:192.1.2.18'
```

Note:

- For more information about Oracle VM Guest Additions, see "Using the Oracle VM Guest Additions" in the *Oracle VM Utilities Guide for x86* at http://docs.oracle.com/cd/E35328_01/E35333/html/vmutl-guestadd.html.
- Refer to the whitepaper *Oracle Database Appliance: Automated Virtual Machine Provisioning* for more information.

Related Topics

- <http://www.oracle.com/technetwork/database/database-appliance/overview/oda-automatedvmprovisioning-2348232.pdf>

4.8.7 Opening a Virtual Machine Console for a Virtual Machine

Use the `oakcli show vmconsole` command to open a virtual machine console window for an active virtual machine

If the console does not display correctly, then close the console, set the `DISPLAY` environment variable to an appropriate value for your monitor, and then rerun the `oakcli show vmconsole` command.

You can also configure your virtual machine (using `oakcli modify vm` command with the `-s` parameter) to allow access from the OAKCLI command line instead of a graphical user interface (GUI) virtual machine console.

Use the `oakcli show vmconsole vm_name` to open a console for a virtual machine. Open a For example, use the following command to open a console for the virtual machine named `vm1_odarepol`:

```
oakcli show vmconsole vm1_odarepol
```

4.8.8 Creating an Image for a New Virtual Machine

Use the `oakcli clone vm` command to create an image for a new virtual machine on Oracle Database Appliance Virtualized Platform.

By default, the image inherits the content and configuration information from the template or from the virtual machine that you are cloning and resides in the same repository as the source. Unless you are using local repositories for your virtual machines, include the `-node` clause in the `oakcli clone` command to identify the node that should run the cloning process. To create a snap clone, which will only contain the configuration metadata, include the `-snap` clause in the `oakcli clone` command.

4.8.9 Setting Up a Virtual Machine for Access from eth0 Using an IP Address

Configure a network device (`eth0`) with an IP address for a virtual machine.

The following set of commands configures the virtual machine `vmol6u3` (which has `ovmd`) with the IP address `192.168.16.51` for the `eth0` interface and sets the `root` password.

```
oakcli clone vm vmol6u3 -vmtemplate ol6u3 -repo shrepo -node 0
oakcli modify vm vmol6u3 -addnetwork privl
oakcli start vm vmol6u3
oakcli modify vm vmol6u3 -s 'com.oracle.linux.network.device.0:eth0'
oakcli modify vm vmol6u3 -s 'com.oracle.linux.network.onboot.0:yes'
oakcli modify vm vmol6u3 -s 'com.oracle.linux.network.bootproto.0:static'
oakcli modify vm vmol6u3 -s 'com.oracle.linux.network.ipaddr.0:192.168.16.51'
oakcli modify vm vmol6u3 -s 'com.oracle.linux.network.netmask.0:255.255.255.0'
oakcli modify vm vmol6u3 -s 'com.oracle.linux.root-password:password'
```

4.8.10 Adding or Removing a Virtual Disk to or from a Virtual Machine

Use the `oakcli modify vm` command to add or remove a virtual disk (`vdisk`) from a virtual machine.

Do not use the `-attachvdisk` or the `-detachvdisk` option with the `-addnetwork`, `-deletenetwork`, or `-s key:value` pair parameters.

- To attach a virtual disk to a virtual machine, use the `oakcli modify vm vm_name` command with the `-attachvdisk` clause that names the virtual disk.

```
oakcli modify vm vm_name -attachvdisk vdisk_name
```

- To detach a virtual disk from a virtual machine, use the `oakcli modify vm vm_name` command with the `-detachvdisk` clause that names the virtual disk.

```
oakcli modify vm vm_name -detachvdisk vdisk_name
```

4.8.11 Removing a Virtual Machine from a Shared Repository

Use the `oakcli delete vm` command to delete the virtual machine and reclaim its storage and resources.

When you no longer have use for a particular virtual machine, delete the machine. When deleting the machine, you can specify the Oracle Database Appliance node from which you want to remove the virtual machine. If this optional parameter is not included, then the virtual machine is removed from both nodes.

- Delete the virtual machine from Node 1.

For example, run the following command to delete the `ovu22` virtual machine from Node 1.

```
oakcli delete vm ovu22 -server 1
```

- Delete the virtual machine from both nodes.

For example, run the following command to delete the `ovu22` virtual machine from both nodes.

```
oakcli delete vm ovu22
```

4.8.12 Performing a Live Migration for an Oracle Database Appliance Virtual Machine

If your system meets requirements for live migration, then you can use the `oakcli migrate vm` command to migrate a virtual machine from the currently running node to another node.

Live Migration refers to the process of moving a running virtual machine between physical machines without disconnecting the client or application running in the virtual machine. Memory, storage, and network connectivity of the virtual machine are transferred from the original host machine to the destination.

You must meet the following requirements before performing a live migration:

- The virtual machine must be on a shared repository and the repository must be online on both nodes.
- The virtual machine must be running.
- The destination host must have the required resources (memory, CPUs and so on) for successful migration.
- The destination host must have a CPU pool with the same name as the CPU pool of the virtual machine that is being migrated.

Use the `oakcli migrate vm vmname` command to migrate a virtual machine from the currently running node to another node. *vmname* is the name of the virtual machine to be migrated.

When you run this command, the virtual machine must be online and corresponding, and the shared repository must be online on both nodes. If a virtual machine is in the migration process, then OAKCLI will display the virtual machine state as `MIGRATING`.

Example 4-20 Example of Migrating a Virtual Machine from the Currently Running Node to Another Node

This example migrates a virtual machine named `myvm1`

```
# oakcli migrate vm myvm1
```

4.9 How to Create Driver Domain Virtual Machines

Use driver domain virtual machines to improve performance.

- [About Driver Domain Virtual Machines](#) (page 4-31)
Use driver domain virtual machines to improve performance by enabling guest virtual machines (VMs) to use `ODA_BASE` instead of `Dom0` to access virtual disks.
- [Creating a Driver Domain Virtual Machine from a Template](#) (page 4-32)
Create a driver domain virtual machine from a virtual machine template.
- [Converting a Virtual Machine to a Driver Domain Virtual Machine](#) (page 4-33)
Convert a guest virtual machine to a driver domain virtual machine to improve performance.
- [Converting a Root Disk to a Driver Domain Disk](#) (page 4-34)
Set up your guest virtual machine (guest VM) root disk as a driver domain and create a new disk as the boot driver.

4.9.1 About Driver Domain Virtual Machines

Use driver domain virtual machines to improve performance by enabling guest virtual machines (VMs) to use `ODA_BASE` instead of `Dom0` to access virtual disks.

A *driver domain* is a user domain that has special privileges and responsibilities for a particular piece of hardware. When you use the driver domain option, the newly created virtual disks are mounted directly from `ODA_BASE` to a guest virtual machine. The option improves I/O performance by enabling guest virtual machines to use `ODA_BASE` instead of `Dom0` to access virtual disks.

The driver domain functionality applies to non-system disks. Once a virtual machine is created in driver domain mode, any new vDisks are added in driver domain mode. Newly created virtual disks are mounted directly from `ODA_BASE` to a guest virtual machine. To determine if a virtual machine is configured in driver domain mode, use the `oakcli show vm vmname` command. When the virtual machine is in driver mode, the output for the `DriverDomain` attribute is `TRUE`.

The virtual disk and `vm.cfg` files are stored in the following directories:

- `Dom0: /Repositories/vm_repo_name/.ACFS/snaps/vm_name/VirtualMachines/vm_name`
- `ODA_BASE: /app/sharedrepo/vm_repo_name/.ACFS/snaps/vm_name/VirtualMachines/vm_name`

The driver domain only works when you add virtual disks to a guest virtual machine. When a virtual machine is in driver domain mode, the corresponding virtual machine configuration file, `vm.cfg`, has the following disk entries:

When `-driverdomain` is specified, the cloned virtual machine is configured with the driver domain. The corresponding virtual machine configuration file, `vm.cfg`, has the following disk entries:

```
disk = [u'file:/OVS/Repositories/repo5/.ACFS/snaps/vm10/
VirtualMachines/
vm10/System.img,xvda,w',
u'file:/u01/app/sharedrepo/repo5/.ACFS/snaps/
vm10/VirtualMachines/vm10/u01.img,xvdb,w,oakDom1']
```

All disks, with the exception of the `xvda` boot disk, have the path from `oakDom1`, that is `odabase`.

The following guest operating systems are supported for driver domain virtual machines:

- Oracle Linux with the latest Unbreakable Enterprise Kernel 2 (UEK2) or Unbreakable Enterprise Kernel 3 (UEK3).
- Microsoft Windows with Oracle VM Windows PV Driver 3.4.1. Oracle VM Windows PV Driver 3.4.1 release is available for download on My Oracle Support as patch number 23346086.
- Oracle Solaris 11.3 or higher x86.

4.9.2 Creating a Driver Domain Virtual Machine from a Template

Create a driver domain virtual machine from a virtual machine template.

Several options are available to create, or import, a template that you will use to create the clone. Determine the virtual machine template you want, the method to import the template, and the naming convention for the template.

This example imports a virtual machine template from `Dom0` and uses the template to create a driver domain virtual machine. The virtual machine image is named `myol6u_test myol6u_ol5u7_vm_alpha` from the virtual machine template named `myol6u_15gb1 (OL5U7)`, which is stored in the shared repository named `repo2 (odarepo1)` on Node 0 in driver domain mode.

This example

1. Use the `oakcli import vmtemplate` command to import a virtual machine template and name the template.

For example, import virtual machine template `OVM_OL5U7_X86_64_PVM_10GB.tgz` from the `/OVS` directory in `Dom0` into the `odarepo1` shared repository on Node 0 in driver domain mode and name the template file `OL5U7`.

```
oakcli import vmtemplate OL5U7 -files /OVS/OVM_OL5U7_X86_64_PVM_10GB.tgz -repo
odarepo1
```

2. Use the `oakcli clone vm` command to create a clone that uses the driver domain.

For example, create a virtual machine image named `vm1_ol5u7` from the virtual machine template named `OL5U7`, which is stored in the shared repository named `odarepo1` on Node 0:

clone virtual machine

```
oakcli clone vm vm1_ol5u7 -vmtemplate OL5U7 -repo odarepo1 -node 0 -driverdomain
```

3. Run the `oakcli show vm` command to confirm that the virtual machine is configured in driver domain mode.

When the virtual machine is in driver mode, the output for the `DriverDomain` attribute is `TRUE`.

```
oakcli show vm vm1_ol5u7
```

4. Use the `oakcli start vm` command to start the virtual machine.

For example, start the virtual machine named `vm1_ol5u7` on Node 0.

```
oakcli start vm vm1_ol5u7 -node 0
```

Related Topics

- [oakcli import vmtemplate](#) (page 5-40)
Use the `oakcli import vmtemplate` command to import virtual machine templates.
- [oakcli clone vm](#) (page 5-9)
Use the `oakcli clone vm` command to create clones and snap clones of virtual machines.
- [oakcli show vm](#) (page 5-68)
Use the `oakcli show vm` command to display information about virtual machines.
- [oakcli start vm](#) (page 5-71)
Use the `oakcli start vm` command to start a virtual machine on a node.

4.9.3 Converting a Virtual Machine to a Driver Domain Virtual Machine

Convert a guest virtual machine to a driver domain virtual machine to improve performance.

You can clone an existing virtual machine that uses `Dom0` to create a clone virtual machine that uses the driver domain `ODA_BASE` instead of `Dom0`.

In this example, virtual machine `vm-dom0_ol5u7` is on `Dom0` and is not a driver domain virtual machine. The example creates a clone virtual machine named `vm-dd1_ol5u7` that uses the driver domain `ODA_BASE`.

1. Use the `oakcli stop` command to shut down the virtual machine.

For example, stop the virtual machine named `vm-dom0_ol5u7`. Shutting down the virtual machine ensures that there is consistent data from the virtual machine (vm) and virtual disks (vdisk)

```
oakcli stop vm vm2_ol5u7 -force
```

2. Detach the virtual disk (vdisk) from `vm-dom0_ol5u7`

3. Use the `oakcli clone vm` command to clone a new virtual machine from the original.

Create a new virtual machine named `vm-dd1_ol5u7` from the original virtual machine named `vm-dom0_ol5u7`. Use the `-snap` option to create a snapshot of the source virtual machine. Because the original virtual machine is not a driver domain machine, use the `-force` and `-driverdomain` options to create a clone virtual machine that does use the driver domain.

```
oakcli clone vm vm-dd1_ol5u7 -vm vm-dom0_ol5u7 -snap -force -driverdomain
```

4. Attach the virtual disk (vdisk) that you detached from the source virtual machine in Step 2 to the new driver domain virtual machine.

Attaching the vdisk ensures that the `vm.cfg` has the disk information with the driver domain feature.

5. Verify that `oakDom1` is the vdisk in the new `vm.cfg`.
6. Run the `oakcli show vm` to confirm that the newly created virtual machine is configured in driver domain mode.

When the virtual machine, `vm-dd1_ol5u7`, is in driver domain mode, the output for the `DriverDomain` attribute is `TRUE`.

```
oakcli show vm vm-dd1_ol5u7
```

7. Use the `oakcli start vm` command to start the virtual machine.

For example, start the virtual machine named `vm-dd1_ol5u7` on Node 0.

```
oakcli start vm vm-dd1_ol5u7 -node 0
```

Related Topics

- [oakcli stop command](#) (page 5-72)
Use the `oakcli stop` command to stop a virtual machine, to stop a shared repository on a node, or to stop `ODA_BASE` on the local node.
- [oakcli clone vm](#) (page 5-9)
Use the `oakcli clone vm` command to create clones and snap clones of virtual machines.
- [oakcli show vm](#) (page 5-68)
Use the `oakcli show vm` command to display information about virtual machines.
- [oakcli start vm](#) (page 5-71)
Use the `oakcli start vm` command to start a virtual machine on a node.

4.9.4 Converting a Root Disk to a Driver Domain Disk

Set up your guest virtual machine (guest VM) root disk as a driver domain and create a new disk as the boot driver.

This example clones an existing guest virtual machine as a driver domain guest VM and then uses the `OL6U7_x86_64_PVHVM` template to create a guest VM and create a new disk for the boot driver.

Using the driver domain improves the guest VM disk IO performance; however, the driver domain is not applicable for a guest VM virtual disk that is a boot disk. Because the boot disk is generally the root disk, you must create a new disk to be the boot driver.

You can create a guest virtual machine by cloning an existing guest, or use one of the templates, such as `OL6U7_x86_64_PVHVM` or `OVM_OL5U7_X86_64_PVM_10GB.tgz`, that are available in the `/OVS` directory in `Dom0`.

Using driver domains requires at least Oracle Database Appliance version 12.1.2.7.0. In this example, the following is the layout of disks in the original `OL6U7` virtual machine:

```
- boot/root disk '/dev/xvda' (echo -e "p" | fdisk /dev/xvda):
Device Boot Start End Blocks Id System
/dev/xvda1 * 2 503 514048 83 Linux
/dev/xvda2 504 11264 11019264 83 Linux
/dev/xvda3 11265 15360 4194304 82 Linux swap / Solaris
- u01 disk '/dev/xvdb' (echo -e "p" | fdisk /dev/xvdb):
```

```
Device Boot Start End Blocks Id System
/dev/xvdb1 1 13054 104856223+ 83 Linux
```

The `/etc/fstab` is as follows:

```
# cat /etc/fstab
UUID=b072e1e9-05a9-4544-a4dd-b15ba49cea2f / ext4 defaults 1 1
UUID=301e09e2-78e4-47d6-b501-d4f1098b419d /boot ext4 defaults 1 2
UUID=39e5a125-ald8-48f4-9e81-f9e89b4dd51b swap swap defaults 0 0
tmpfs /dev/shm tmpfs defaults 0 0
devpts /dev/pts devpts gid=5,mode=620 0 0
sysfs /sys sysfs defaults 0 0
proc /proc proc defaults 0 0
UUID=770078eb-c083-4d52-81bf-e026ab3f3fa7 /u01 ext4 defaults 1 2
```

The `df -h` is as follows:

```
# df -h
Filesystem Size Used Avail Use% Mounted on
/dev/xvda2 11G 814M 8.9G 9%
/tmpfs 3.9G 0 3.9G 0% /dev/shm
/dev/xvda1 479M 51M 399M 12% /boot
/dev/xvdb1 92G 55G 33G 63% /u01
```

1. Clone a guest VM as a driver domain guest VM.

You can use one of the following commands to clone a virtual machine:

- `oakcli clone vm vm_name -vmtemplate template_name -repo repo_name [-node 0|1] [-driverdomain]`
- `oakcli clone vm vm_name -vmtemplate src_vmtempl_name -snap [-driverdomain]`
- `oakcli clone vm vm_name -vm src_vm_name -snap [-force] [-driverdomain]`

Note:

You must stop the virtual machine before taking a snapshot.

For example, create a driver domain guest VM named `OL6U7` from the `OL6U7_x86_64_PVHVM` source VM template. Use the `-snap` option to designate that you want to create a snapshot of the source virtual machine and the `-driverdomain` option to indicate that the new virtual machine will use the driver domain.

```
oakcli clone vm OL6U7 -vm OL6U7_x86_64_PVHVM -snap -driverdomain
```

2. Create a new boot virtual disk.

```
dd if=/dev/zero of=/u01/app/sharedrepo/repo name/.ACFS/snaps/vm_name/
VirtualMachines/vm_name/virtual diskfile name.img oflag=direct count=0 bs=1M
seek=new size in MB
```

For example, create a 500 MB boot virtual disk named `newboot` for the `OL6U7` virtual machine that is in the `odarepo1` repository:

```
# dd if=/dev/zero of=/u01/app/sharedrepo/odarepo1/.ACFS/snaps/OL6U7/
VirtualMachines/OL6U7/newboot.img oflag=direct count=0 bs=1M seek=500
```

3. Edit the `vm.cfg` file to attach the new boot disk to your guest VM.

- a. Navigate to the `vm.cfg` file.

```
/u01/app/sharedrepo/vm repo/.ACFS/snaps/vm name/VirtualMachines/vm name/
vm.cfg
```

For example, the OL6U7 virtual machine is in the odarepo1 repository:

```
/u01/app/sharedrepo/odarepo1/.ACFS/snaps/OL6U7/VirtualMachines/OL6U7/vm.cfg
```

b. Add the new disk entry on the disk parameter.

```
disk = ['file:virtual disk file path,virtual device,r/w option']
```

For example, add the newboot virtual disk for the OL6U7 virtual machine, which is in the odarepo1 repository.

```
disk =
[u'file:/OVS/Repositories/odarepo1/.ACFS/snaps/OL6U7/VirtualMachines/
OL6U7/15f96d92a66c4b808035116ab6348d0d.img,xvda,w',
u'file:/u01/app/sharedrepo/odarepo1/.ACFS/snaps/oakvdk_ol6u7_u01/
VirtualDisks/oakvdk_ol6u7_u01,xvdb,w,oakDom1',
u'file:/u01/app/sharedrepo/odarepo1/.ACFS/snaps/oakvdk_ol6u7_bootdisk/
VirtualDisks/oakvdk_ol6u7_bootdisk,xvdc,w,oakDom1']
(...)
```

The following example shows the newboot virtual disk:

```
disk =
[u'file:/OVS/Repositories/odarepo1/.ACFS/snaps/OL6U7/VirtualMachines/
OL6U7/15f96d92a66c4b808035116ab6348d0d.img,xvda,w',
u'file:/u01/app/sharedrepo/odarepo1/.ACFS/snaps/oakvdk_ol6u7_u01/
VirtualDisks/oakvdk_ol6u7_u01,xvdb,w,oakDom1',
u'file:/OVS/Repositories/odarepo1/.ACFS/snaps/OL6U7/VirtualMachines/OL6U7/
newboot.img,xvdc,w']
(...)
```

4. Stop and restart your guest VM.

```
oakcli stop vm vm_name
oakcli start vm vm_name
```

For example, stop and restart the OL6U7 guest.

```
oakcli stop vm OL6U7oakcli start vm OL6U7
```

The new disks are available to the guest VM after the restart.

5. Create a disk partition on the new boot driver.

A new empty virtual disk appears as an /dev/xvdc device.

```
# dmesg |grep xvdc
blkfront: xvdc: flush diskcache: enabled; persistent grants: enabled; indirect
descriptors: enabled;
xvdc: unknown partition table
```

Use the fdisk command to partition the disk and make the partition bootable.

```
echo -e "n\np\n1\n\n\nnt\n83\na\n1\nw" | fdisk /dev/xvdc
Device      Boot Start End Blocks Id System
/dev/xvdc1 *          1  63  506016 83 Linux
```

6. Format the new boot disk partition /dev/xvdc1.

```
mkfs.ext4 /dev/xvdc1
```

7. Setup and mount the new boot disk partition and get the single blockID.

```
mkdir /virtual diskfile namemount /dev/xvdc1 /virtual diskfile name
```

a. Setup and mount the new boot disk.

```
mkdir /virtual diskfile namemount /dev/xvdc1 /virtual diskfile name
```

For example, make a directory and mount the `newboot` boot disk:

```
mkdir /newbootmount /dev/xvdc1 /newboot
```

b. Get the single blockID.

```
# blkid /dev/xvdc1/dev/xvdc1: UUID="3d7a177b-0fa0-4212-9c0c-c5554bb1817a"
TYPE="ext4"
```

8. Copy the original boot content to the new boot disk.

```
cp -dpR /boot/* /virtual diskfile name
```

For example, for the disk named `newboot`:

```
cp -dpR /boot/* /newboot
```

9. Make the new boot partition the active boot partition

```
umount /virtual diskfile nameumount /bootmount /dev/xvdc1 /boot
```

```
umount /newbootumount /bootmount /dev/xvdc1 /boot
```

10. Setup Grub in the new boot disk.

Use the `grub` or `grub2` command, where `/dev/xvdc` is the new boot disk device.

- If you are using Oracle Linux 6U7, use `grub`:

```
# grub
grub> device (hd0) /dev/xvdc
grub> root (hd0,0)
grub> setup (hd0)
```

- If you are using Oracle Linux 7u2, use `grub2`:

```
# grub2-mkconfig -o /boot/grub2/grub.cfg
# grub2-install /dev/xvdc
```

The following example uses `grub`:

```
# grub
Probing devices to guess BIOS drives. This may take a long time.
GNU GRUB version 0.97 (640K lower / 3072K upper memory)
[ Minimal BASH-like line editing is supported. For the first word, TAB
lists possible command completions. Anywhere else TAB lists the possible
completions of a device/filename.]
grub> device (hd0) /dev/xvdc
device (hd0) /dev/xvdc
grub> root (hd0,0)
root (hd0,0)
Filesystem type is ext2fs, partition type 0x83
grub> setup (hd0)
setup (hd0)
Checking if "/boot/grub/stage1" exists... no
Checking if "/grub/stage1" exists... yes
Checking if "/grub/stage2" exists... yes
Checking if "/grub/e2fs_stage1_5" exists... yes
Running "embed /grub/e2fs_stage1_5 (hd0)"... 27 sectors are embedded.
succeeded
```

```
Running "install /grub/stage1 (hd0) (hd0)1+27 p (hd0,0)/grub/stage2 /grub/
grub.conf"... succeeded
Done.
grub> quit
quit
```

The following example uses grub2:

```
# grub2-mkconfig -o /boot/grub2/grub.cfg
Generating grub configuration file ...
Found linux image: /boot/vmlinuz-3.10.0-327.3.1.el7.x86_64
Found initrd image: /boot/initramfs-3.10.0-327.3.1.el7.x86_64.img
Found linux image: /boot/vmlinuz-3.8.13-118.2.1.el7uek.x86_64
Found initrd image: /boot/initramfs-3.8.13-118.2.1.el7uek.x86_64.img
Found linux image: /boot/vmlinuz-0-rescue-8f9df86c6d4c4640a01315a3aa93790e
Found initrd image: /boot/initramfs-0-
rescue-8f9df86c6d4c4640a01315a3aa93790e.img
done

# grub2-install /dev/xvdc
Installing for i386-pc platform.
Installation finished.
No error reported.
```

11. Edit `/etc/fstab` with the new boot device.

```
UUID=b072e1e9-05a9-4544-a4dd-b15ba49cea2f / ext4 defaults 1 1
#UUID=301e09e2-78e4-47d6-b501-d4f1098b419d /boot ext4 defaults 1 2 <----
Original boot device
UUID=3d7a177b-0fa0-4212-9c0c-c5554bb1817a /boot ext4 defaults 1 2

UUID=39e5a125-a1d8-48f4-9e81-f9e89b4dd51b swap swap defaults 0 0
tmpfs /dev/shm tmpfs defaults 0 0
devpts /dev/pts devpts gid=5,mode=620 0 0
sysfs /sys sysfs defaults 0 0
proc /proc proc defaults 0 0

UUID=770078eb-c083-4d52-81bf-e026ab3f3fa7 /u01 ext4 defaults 1 2
```

12. Edit the `vm.cfg` file and make the new boot virtual disk the first disk on the list.

Note:

The driver domain device use the following root path `/u01/app/sharedrepo`. The boot disk root path is `/OVS/Repositories`.

The entries in the disk section of the `vm.cfg` file will look something like the following:

```
u'file:/OVS/Repositories/rcrepo/.ACFS/snaps/OL6U7/VirtualMachines/
OL6U7/15f96d92a66c4b808035116ab6348d0d.img,xvda,w',
<<-- original boot/root disk
u'file:/u01/app/sharedrepo/rcrepo/.ACFS/snaps/oakvdk_ol6u7_u01/VirtualDisks/
oakvdk_ol6u7_u01,xvdb,w,oakDoml',
<<-- original u01 disku'file:/OVS/Repositories/rcrepo/.ACFS/snaps/OL6U7/
VirtualMachines/OL6U7/newboot.img,xvdc,w'
<<-- new boot disk
```

Move the new boot virtual disk, `newboot`, to the first disk on the list.

```

u'file:/OVS/Repositories/rcrepo/.ACFS/snaps/OL6U7/VirtualMachines/OL6U7/
newboot.img,xvda,w'
<<-- new boot disk
u'file:/u01/app/sharedrepo/rcrepo/.ACFS/snaps/OL6U7/VirtualMachines/
OL6U7/15f96d92a66c4b808035116ab6348d0d.img,xvdb,w,oakDom1
<<-- original boot/root disk
u'file:/u01/app/sharedrepo/rcrepo/.ACFS/snaps/
oakvdk_ol6u7_u01/VirtualDisks/oakvdk_ol6u7_u01,xvdc,w,oakDom1'
<<-original u01 disk

```

The new boot device (`xvdc`) becomes the first device (not driver domain) and `xvda` is the second domain driver device.

The following is an example of the `vm.cfg` before the edit:

```

# cat vm.cfg
vif = ['type=netfront,bridge=net1']
name = 'OL6U7'
extra = 'NODENAME=OL6U7'
builder = 'hvm'
cpus =
'24,25,26,27,28,29,30,31,32,33,34,35,36,37,38,39,40,41,42,43,44,45,46,47,48,49,50
,51,52,53,54,55,56,57,58,59,60,61,62,63,64,65,6
vcpus = 2
memory = 8192
cpu_cap = 0
vnc = 1
serial = 'pty'
disk =
[u'file:/OVS/Repositories/rcrepo/.ACFS/snaps/OL6U7/VirtualMachines/
OL6U7/15f96d92a66c4b808035116ab6348d0d.img,xvda,w' ,
u'file:/u01/app/sharedrepo/rcrepo/.ACFS/snaps/oakvdk_ol6u7_u01/VirtualDisks/
oakvdk_ol6u7_u01,xvdb,w,oakDom1' ,
u'file:/OVS/Repositories/rcrepo/.ACFS/snaps/OL6U7/VirtualMachines/OL6U7/
newboot.img,xvdc,w' ]
maxvcpus = 2
maxmem = 8192

```

The following is an example of the `vm.cfg` after the edit, where the new boot device (`xvdc`) is the first device and `xvda` is the driver domain device:

```

# cat vm.cfg
vif = ['type=netfront,bridge=net1']
name = 'OL6U7'
extra = 'NODENAME=OL6U7'
builder = 'hvm'
cpus =
'24,25,26,27,28,29,30,31,32,33,34,35,36,37,38,39,40,41,42,43,44,45,46,47,48,49,50
,51,52,53,54,55,56,57,58,59,60,61,62,63,64,65,6
vcpus = 2
memory = 8192
cpu_cap = 0
vnc = 1
serial = 'pty'
disk =[
[u'file:/OVS/Repositories/rcrepo/.ACFS/snaps/OL6U7/VirtualMachines/OL6U7/
newboot.img,xvda,w' ,
u'file:/u01/app/sharedrepo/u'file:/u01/app/sharedrepo/rcrepo/.ACFS/snaps/
oakvdk_ol6u7_u01/VirtualDisks/oakvdk_ol6u7_u01,xvdc,w,oakDom1' ]
maxvcpus = 2
maxmem = 8192

```

13. Stop and restart the guest VM

```
oakcli stop vm vm_name
oakcli start vm vm_name
```

```
oakcli stop vm OL6U7
oakcli start vm OL6U7
```

14. Check the layout of the new disks.

The layout should be similar to the following:

```
# df -h
Filesystem Size Used Avail Use% Mounted on/dev/xvdb2 11G 814M 8.9G 9% /
tmpfs 3.9G 0 3.9G 0% /dev/shm
/dev/xvda1 471M 51M 391M 12% /boot
/dev/xvdc1 92G 55G 33G 63% /u01
```

The swap device is now under the driver domain: /dev/xvdb

```
# swapon -s
Filename Type Size Used Priority
/dev/xvdb3 partition 4194300 0 -1
```

15. (Optional) Synchronize the oakcli virtual machine inventory with the `vm.cfg` file.

When you edit the `vm.cfg` file, the `oakcli show vm vm_name` output displays incorrect information about the disk. You can create a temporary duplicate (snapshot) of the virtual machine to fix the output.

```
oakcli stop vm vm_name
oakcli clone vm tmp_vm_name -vm vm_name -snap -driverdomain
oakcli delete vm vm_name
oakcli clone vm vm_name -vm tmp_vm_name -snap -driverdomain
oakcli delete vm tmp_vm_name
```

Note:

Stop the virtual machine before taking a snapshot.

For example, create a temporary clone called `tmp_OL6U7` of the virtual machine `OL6U7` using the `-snap` and `-driverdomain` options. Delete the virtual machine `OL6U7`, and then use the temporary clone to create a new clone. Delete the temporary virtual machine.

```
oakcli stop vm OL6U7
oakcli clone vm tmp_OL6U7 -vm OL6U7 -snap -driverdomain
oakcli delete vm OL6U7
oakcli clone vm OL6U7 -vm tmp_OL6U7 -snap -driverdomain
oakcli delete vm tmp_OL6U7
```

Note:

The `oakcli clone vm` command creates a duplicate (snapshot) of the VDIs that are attached to the guest VM. Use the `oakcli delete vdisk` command to remove the orphan VDIs.

Run the `oakcli show vm vm_name` command to verify that the oakcli virtual machine inventory is in sync with the `vm.cfg` file.

```

# oakcli show vm OL6U7
The Resource is : OL6U7
AutoStart : restore
CPUPriority : 100
Disks : |file:/OVS/Repositories/rcrepo/.ACFS/snaps/OL6U7/VirtualMachines/OL6U7/newboot.img,xvda,w||file:/u01/app/sharedrepo/rcrepo/.ACFS/snaps/OL6U7/VirtualMachines/OL6U7/15f96d92a66c4b808035116ab6348d0d.img,xvdb,w,oak
Dom1 |
Domain : XEN_PVM
DriverDomain : True
ExpectedState : offline
FailOver : false
IsSharedRepo : true
Keyboard : en-us
MaxMemory : 8192M
MaxVcpu : 2
Memory : 8192M
Mouse : OS_DEFAULT
Name : OL6U7
Networks : |type=netfront,bridge=net1|
NodeNumStart : 0
OS : OL_5
PrefNodeNum : 0
PrivateIP : None
ProcessorCap : 0
RepoName : rcrepo
State : Offline
TemplateName : tmp_OL6U7
VDisks : |oakvdk_snap_3_ol6u7_u01_rcrepo|
Vcpu : 2
cpupool : default-unpinned-pool

```

4.10 How to Manage High Availability on Oracle Database Appliance Virtualized Platform

Use the `oakcli configure vm` command to configure high availability services for your virtual machines.

A system that is highly available is designed to provide uninterrupted computing services during essential time periods, during most hours of the day, and during most days of the week throughout the year. Reliability, recoverability, timely error detection, and continuous operations are primary characteristics of a highly available solution. Two essential parts of high availability are automatic restart and failover.

Unless you are using local repositories, you can set high availability options for your virtual machines. High availability options identify the node where the virtual machine should be started by default and whether the virtual machine should be failed over to the other node. Failover can occur if the node where the virtual machine is already running fails or if the preferred node is not available when the virtual machines attempt to start.

Configuring Automatic Restart for High Availability

A virtual machine automatically restarts after a hardware or software failure or whenever your database host computer restarts. Use the `oakcli configure vm` command to start a virtual machine on a preferred node by using the `-prefnode` option.

Configuring Failover for High Availability

Configuring failover provides high availability by enabling a virtual machine to restart on the other node after an unplanned failure, without requiring manual intervention. Use the command `oakcli configure vm` with the `-failover` option to configure fail over from one node to another.

4.11 How to Manage CPU Pools on Oracle Database Appliance Virtualized Platform

These topics describe how to use OAKCLI to create and manage CPU pools on Oracle Database Appliance Virtualized Platform.

- [About Managing CPU Pools for Resource Allocation](#) (page 4-42)
Use CPU pools to cage and manage resource allocations to workloads for virtual machines on Oracle Database Appliance Virtualized Platforms.
- [About Over-Subscribed CPU Pools](#) (page 4-44)
Configure virtual machines so that they do not subscribe to more CPU resources than the resources available in CPU pools.
- [Creating a New CPU Pool on Oracle Database Appliance Virtualized Platform Nodes](#) (page 4-44)
Use the command `oakcli create cpupool` to create a CPU pool.
- [Showing the CPU Pools Configured on Oracle Database Appliance Virtualized Platform Nodes](#) (page 4-44)
Use the command `oakcli show cpupool` command to display the CPUs assigned to each defined CPU pool.
- [Changing the Number of CPUs Assigned to a CPU Pool on Oracle Database Appliance Virtualized Platform Nodes](#) (page 4-45)
Use the `oakcli configure cpupool` command to change the number of CPUs assigned to a CPU pool.
- [Assigning a Virtual Machine to a CPU Pool on Oracle Database Appliance Virtualized Platform](#) (page 4-45)
Use the command `oakcli configure vm` to assign a virtual machine to a CPU pool.

4.11.1 About Managing CPU Pools for Resource Allocation

Use CPU pools to cage and manage resource allocations to workloads for virtual machines on Oracle Database Appliance Virtualized Platforms.

Workloads are isolated by creating CPU pools and assigning (pinning) virtual machines to a specific CPU pool. When you pin a virtual machine to a CPU pool, you ensure that the virtual machine uses CPUs in only that CPU pool.

When you initially configure Oracle Database Appliance Virtualized Platform, a default-unpinned-pool is created on each node. The size of this pool depends on the hardware model:

- On Oracle Database Appliance X5-2 Virtualized Platform, the default-unpinned-pool contains 72 CPUs.
- On Oracle Database Appliance X4-2 Virtualized Platform, the default-unpinned-pool contains 48 CPUs.
- On Oracle Database Appliance X3-2 Virtualized Platform, the default-unpinned-pool contains 32 CPUs.
- On Oracle Database Appliance Version 1 Virtualized Platform, the default-unpinned-pool contains 24 CPUs.

When you create the ODA_BASE domain, a new CPU pool is created on both nodes. The pool is named `odaBaseCpuPool`. The CPUs required for this pool are removed from the default-unpinned-pool. ODA_BASE is the only domain allowed to use the CPUs in the `odaBaseCpuPool`. When you start other virtual machines, the virtual machines run on CPUs that are left in the default-unpinned-pool, effectively removing ODA_BASE from the work being done by other virtual machines.

You can also cage groups of virtual machines by creating additional CPU pools. These additional pools enable you to pin a virtual machine, or a set of virtual machines, to its own CPU pool. Virtual machines running in a specific CPU pool do not share CPU cycles with virtual machines running in other CPU pools. Define as many CPU pools as you want, up to the number of available CPUs on your system.

If your application requirements change over time, then Oracle recommends that you resize, add, or drop CPU pools as needed to make the best use of your resources. You may also want to resize ODA_BASE. However, if you want to resize ODA_BASE, then you must use a special command that also updates your Oracle Database Appliance Virtualized Platform license.

Example 4-21 Example of Showing CPU Pools on a Node

A CPU pool can have a different size on each node (except for the `odaBaseCpuPool`), as shown by the following `oakcli show cpupool` commands, one for each node:

```
oakcli show cpupool -node 0
      Pool                               Cpu List
default-unpinned-pool [14, 15, 16, 17, 18, 19, 20, 2
                        1, 22, 23]
      twocpu                             [12, 13]
      odaBaseCpuPool [0, 1, 2, 3, 4, 5, 6, 7, 8, 9,
                        10, 11]
```

```
oakcli show cpupool -node 1
      Pool                               Cpu List
default-unpinned-pool [12, 13, 14, 15, 16, 17, 18, 1
                        9, 20, 21, 22, 23]
      odaBaseCpuPool [0, 1, 2, 3, 4, 5, 6, 7, 8, 9,
                        10,11]
```

Related Topics

- [Creating a New CPU Pool on Oracle Database Appliance Virtualized Platform Nodes](#) (page 4-44)
Use the command `oakcli create cpupool` to create a CPU pool.

4.11.2 About Over-Subscribed CPU Pools

Configure virtual machines so that they do not subscribe to more CPU resources than the resources available in CPU pools.

A CPU resource can belong to one, and only one, CPU pool. You can assign multiple virtual machines to a CPU pool. A CPU pool becomes oversubscribed when the virtual machines that are active in the pool require more CPUs than you configured for the pool. For example, if a CPU pool has four CPUs, then you can start two virtual machines that are defined to use four CPUs each. In this case, the CPU pool is oversubscribed, because each of the four CPUs is supporting two virtual machines.

If you stop one of those virtual machines, but start another one that requires two CPUs, then the CPU pool is still oversubscribed. This is because two of the CPUs are supporting both virtual machines. When oversubscribing a CPU pool, assess the performance of the virtual machines in that pool. Reassign one or more virtual machines to a different CPU pool if sharing an oversubscribed pool degrades performance to unacceptable levels.

4.11.3 Creating a New CPU Pool on Oracle Database Appliance Virtualized Platform Nodes

Use the command `oakcli create cpupool` to create a CPU pool.

Manage resource use by creating CPU pools, and then assign these resources to virtual machines.

Example 4-22 Example of Creating a New CPU Pool on Oracle Database Appliance Virtualized Platform Nodes

This example creates a CPU pool named `winpool` that is allocated 4 CPUs on Node 0:

```
oakcli create cpupool winpool -numcpu 4 -node 0
```

4.11.4 Showing the CPU Pools Configured on Oracle Database Appliance Virtualized Platform Nodes

Use the command `oakcli show cpupool` command to display the CPUs assigned to each defined CPU pool.

You can use `oakcli show cpupool` to display any virtual machines assigned to each CPU pool.

Example 4-23 Example of Showing CPUs Assigned to Defined CPU Pools on Oracle Database Appliance Virtualized Platform Nodes

This `oakcli show cpupool` example shows the CPUs assigned to each defined CPU pool on Node 0:

```
oakcli show cpupool -node 0
```

4.11.5 Changing the Number of CPUs Assigned to a CPU Pool on Oracle Database Appliance Virtualized Platform Nodes

Use the `oakcli configure cpupool` command to change the number of CPUs assigned to a CPU pool.

An Oracle VM Server can belong to only one virtual pool. However, you can change the resources allocated to a virtual pool to increase the CPU resources available to the virtual machine.

Example 4-24 Example of Changing the Number of CPUs Assigned to a CPU Pool on Oracle Database Appliance Virtualized Platform Nodes

This `oakcli configure cpupool` example changes the number of CPUs assigned to the CPU pool named `linpool` on Node 1. After the command runs, the new number of CPU resources assigned to the CPU are six.

```
oakcli configure cpupool linpool -numcpu 6 -node 1
```

4.11.6 Assigning a Virtual Machine to a CPU Pool on Oracle Database Appliance Virtualized Platform

Use the command `oakcli configure vm` to assign a virtual machine to a CPU pool.

Review the availability of CPU pools on nodes as part of your placement policy for virtual machines on Oracle Database Appliance Virtualized Platforms.

If your virtual machine is assigned to a specific CPU pool, and the virtual machine is allowed to fail over, then the virtual machine attempts to use the same CPU pool on the secondary node. If the CPU pool exists on the other node, but the CPU pool is a different size, then the performance of your virtual machine can be affected when it runs on the secondary node. If the assigned CPU pool does not exist on the secondary node, then the virtual machine cannot fail over.

Note:

Do not manage `odaBaseCpuPool` by using `oakcli cpupool` commands. Instead, use commands that configure `ODA_BASE`, as discussed in "How to Resize `ODA_BASE`."

Example 4-25 Example of Assigning a Virtual Machine to a CPU Pool on Oracle Database Appliance Virtualized Platform

This `oakcli configure vm` example pins the virtual machine named `wintest` to the CPU pool named `winpool`:

```
oakcli configure vm wintest -cpupool winpool
```

4.12 About Network Infrastructure and Virtual Local Area Networks on Oracle Database Appliance Virtualized Platform

To specify which network you want to use to access a virtual machine, you employ network infrastructure components of Oracle Database Appliance Virtualized Platform.

Oracle Database Appliance Virtualized Platform manages all of the high-level network infrastructure components for you by pre-creating the bridges for all networks. The front-end point for accessing a virtual machine is one of the bridges defined for `Dom0`.

The network interfaces differ, depending on your Oracle Database Appliance hardware. In all cases, connections to user domains are through the selected interfaces. Refer to the tables for your Oracle Database Appliance. Refer to the figure "Basic Virtual Machine Local Area Network" for an overview of network interface configuration.

Oracle Database Appliance Version 1 Virtualized Platform Network Interfaces

The following table lists the default network interfaces for Oracle Database Appliance Virtualized Platform on Oracle Database Appliance version 1 (systems without an external storage shelf).

Table 4-2 Oracle Database Appliance Version 1 Virtualized Platform Network Interfaces

Type	Interfaces at Dom0	Bond Devices at Dom0	Bridge in Dom0	Interfaces in ODA_BASE Domain
Private	eth0 eth1	bond0	priv1	eth0
On Board Public	eth2 eth3	bond1	net1	eth1
1st Pair Quad Port	eth4 eth5	bond2	net2	eth2
2nd Pair Quad Port	eth6 eth7	bond3	net3	eth3
10-GbE Interface	eth8 eth9	xbond0	net4	eth4



Note:

If you define a fiber (instead of copper) public network connection, then `bond0` is configured on PCIe boards.

Oracle Database Appliance Virtualized Platform Network Interfaces for Oracle Database Appliance X3-2 and later

The following two tables the default network interfaces for Oracle Database Appliance Virtualized Platform on Oracle Database Appliance X3-2 and later (systems with an external storage shelf).

Table 4-3 Oracle Database Appliance Virtualized Platform Dual Port 10-GbE Network Interfaces (Oracle Database Appliance X3-2 and later)

Interfaces at Dom0	Bond Devices at Dom0	Bridge in Dom0	Interfaces in ODA_BASE Domain
1. eth0	icbond0	priv1	eth0
2. eth1			

Table 4-4 Oracle Database Appliance Virtualized Platform On Board Quad Port 10-GbE Network Interfaces (Oracle Database Appliance X3-2 and Later)

Interfaces at Dom0	Bond Devices at Dom0	Bridge in Dom0	Interfaces in ODA_BASE Domain
1. eth2	bond0	net1	eth1
2. eth3			
1. eth4	bond1	net2	eth2
2. eth5			

Note:

If you define a fiber (instead of copper) public network connection, then `bond0` is configured on PCIe boards.

Configuration Overview of Oracle Database Appliance Virtual Machine Local Area Networks

When you configure a virtual machine, you define which network the virtual machine should use by identifying the related bridge.

For example, to connect a virtual machine named `myvm1` to the `net1` network, you would use the following command:

```
oakcli modify vm myvm1 -addnetwork net1
```

The illustration "Basic Virtual Machine Local Area Network" shows a typical Oracle Database Appliance local area network configuration that results from this virtual machine network configuration:

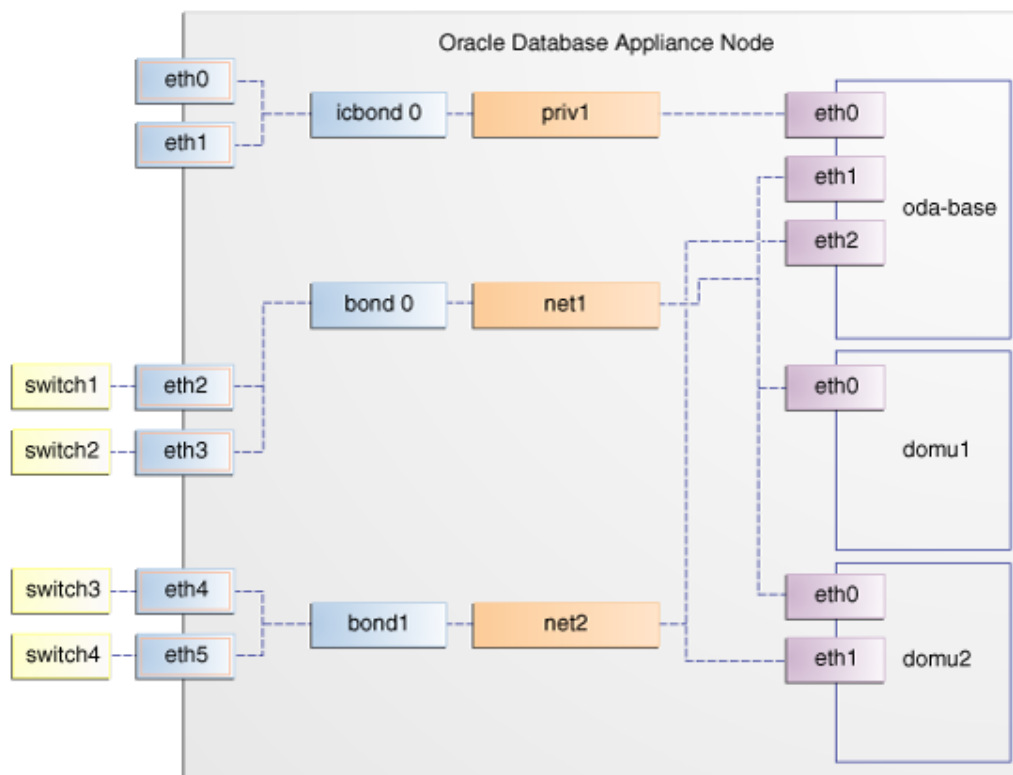
Figure 4-3 Basic Virtual Machine Local Area Network

You assign default Virtual Local Area Networks (VLANs) to ODA_BASE during the installation and configuration of Oracle Database Appliance Virtualized Platform. The figure "Oracle Database Appliance Virtualized Platform with Virtual Local Area Networks" shows a typical Oracle Database Appliance configuration using VLANs. The illustration shows the same configuration as in "Basic Virtual Machine Local Area Networks," but with three tagged VLANs added for backups (backup), for applications (application), and for management (mgnt).

Figure 4-4 Oracle Database Appliance Virtualized Platform with Virtual Local Area Networks

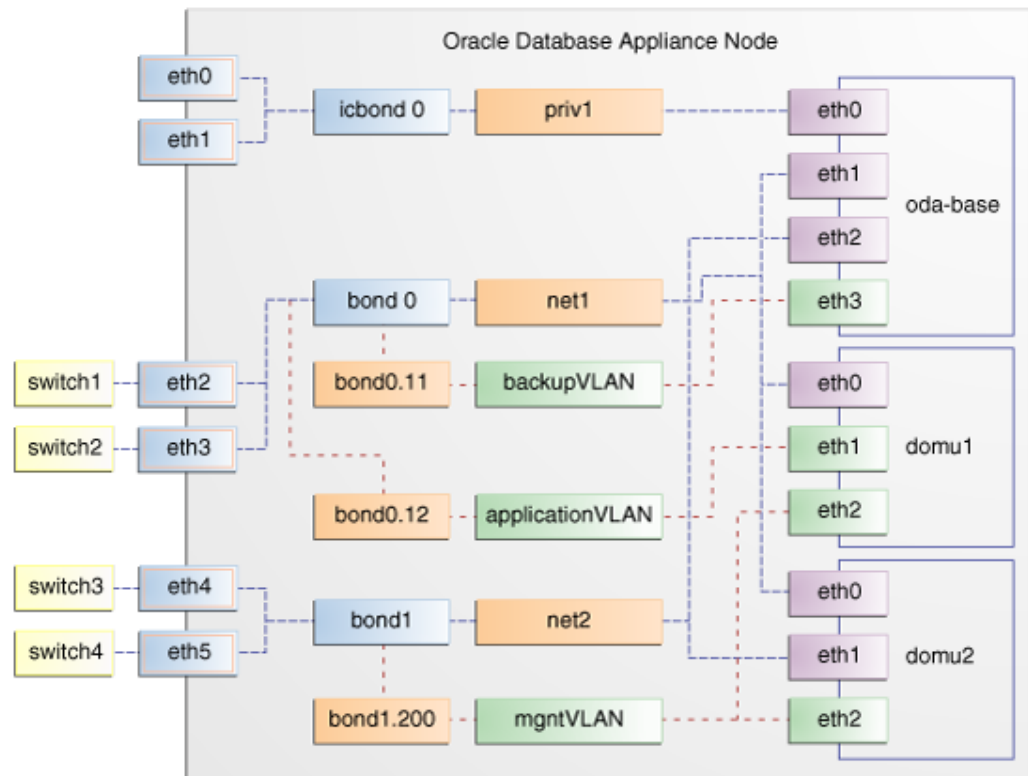

4.13 Managing Virtual Local Area Networks on User Domains and on ODA_BASE

Use these examples to understand how to configure and manage virtual local area networks (VLANs).

To manage VLANs for user domains, log in to ODA_BASE. To manage VLANs for ODA_BASE, log in to Dom0. The examples in this section use a VLAN named `sample10`.

Note:

You can configure VLANs on the physical switches from Dom0 before deploying Oracle Database Appliance or Oracle Database Appliance Virtualized Platform.

Example 4-26 Example of Creating a Virtual Local Area Network

1. Prepare the following information to create a VLAN:
 - A VLAN name that is unique on the node where the VLAN is created (but which can be the same as a VLAN name on the other node of Oracle Database Appliance Virtualized Platform).

- A VLAN tag number between 2 to 4096 inclusive that is unique on the node where the VLAN is created (but which can be the same as a VLAN tag number on the other node of Oracle Database Appliance Virtualized Platform).
 - The name of the interface on which the VLAN is to be created. Find the available interfaces for your hardware listed in the **Bond Devices at Dom0** column in the tables in "About Network Infrastructure and Virtual Local Area Networks on Oracle Database Appliance Virtualized Platform."
 - The node on which to create the VLAN
2. Enter the following command to start creating the VLAN. Enter the information you have prepared when prompted:

```
oakcli create vlan
```

 **Note:**

If you need to create the same VLAN on both nodes, then enter the command `oakcli create vlan` twice: once for Node 0 and once for Node 1.

The following `oakcli create vlan` example creates the VLAN `sample10` on Node 0:

```
oakcli create vlan sample10 -vlanid 10 -if bond0 -node 0
```

 **Caution:**

If you are planning to use a VLAN with a virtual machine created in a shared repository, then create that VLAN on both nodes. A virtual machine fails if an assigned network is not available on the node where the virtual machine is configured to run by default, or where the virtual machine is configured to start up following a failover.

Example 4-27 Example of Assigning and Removing a Virtual Local Area Network for a User Domain

Use the `oakcli modify vm` command with the option `-addnetwork` to assign an existing VLAN to a virtual machine and with a `-deletenetwork` clause to remove a VLAN from a virtual machine. The clauses must also contain the name of the VLAN.

The following `oakcli modify vm` example assigns the `sample10` VLAN to the virtual machine `myol5u_test`:

```
oakcli modify vm myol5u_test -addnetwork sample10
```

Example 4-28 Example of Assigning and Removing a Virtual Local Area Network for ODA_BASE

Use the command `oakcli configure oda_base` to add an existing VLAN to ODA_BASE, or to remove a VLAN from ODA_BASE. Note that this command also enables you to resize ODA_BASE and domain memory size. If you only want to

manage VLANs, then enter the number that corresponds to the number of your current CPU cores and the current number for your memory.

In the following partial example, the CPU core count and default memory values are left unchanged, while the VLAN `test01` is assigned to `ODA_BASE`. Note that the current CPU core count, 6, corresponds to selection number 3 in the Core Licensing Options list of values.

```
# oakcli configure oda_base
Core Licensing Options:
  1. 2 CPU Cores
  2. 4 CPU Cores
  3. 6 CPU Cores
  4. 8 CPU Cores
  5. 10 CPU Cores
  6. 12 CPU Cores
Current CPU Cores      :6
Selection[1 : 6](default 12 CPU Cores) : 3
ODA base domain memory in GB(min 8, max 88)(Current Memory 48G)[default
64]      : 48
INFO: Using default memory size i.e. 64 GB
Additional vlan networks to be assigned to oda_base? (y/n) [n]: y
Select the network to assign (test00,test01,test02,test03): test01
Additional vlan networks to be assigned to oda_base? (y/n) [n]:
Vlan network to be removed from oda_base (y/n) [n]:
INFO: . . .
```

Example 4-29 Example of Viewing Virtual Local Area Networks

To see what VLANs currently exist in `ODA_BASE`, run the `oakcli show vlan` command.

The following example shows VLANs in addition to the `sample10` VLAN used in previous examples:

```
oakcli show vlan

NAME           ID   INTERFACE  NODENUM
----          --   -
net1           1   bond0      0
net1           1   bond0      1
net2           1   bond1      0
net2           1   bond1      1
net3           2   bond1      0
net3           4   bond0      1
net10          20  bond1      0
net10          20  bond1      1
```

Example 4-30 Example of Deleting Virtual Local Area Networks

To remove an unwanted VLAN from a node, use the `oakcli delete vlan` command and provide the VLAN name and the node number.

This example remove the VLAN `sample10` from Node 0 (where the VLAN was assigned in the earlier `oakcli create vlan` example):

```
oakcli delete vlan sample10 -node 0
```

 **Note:**

You cannot delete a native VLAN. A native VLAN is a virtual local area network configured during the deployment of Oracle Database Appliance Virtualized Platform software.

4.14 How to Resize ODA_BASE

You can increase or decrease the number of CPU cores that you assign the ODA_BASE domain to add or reduce computing power and memory as required for your workloads.

Topics:

- [About Resizing ODA_BASE](#) (page 4-52)
Oracle recommends that you use the following guidelines in reviewing your ODA_BASE resource allocation, and in carrying out resizing.
- [Changing the ODA_BASE Core Count](#) (page 4-52)
After you have reviewed the guidelines about resizing ODA_BASE, complete these steps to change the ODA_BASE core count.

4.14.1 About Resizing ODA_BASE

Oracle recommends that you use the following guidelines in reviewing your ODA_BASE resource allocation, and in carrying out resizing.

Increase the number of CPU cores assigned to the ODA_BASE domain on Oracle Database Appliance Virtualized Platform if you need more computing power or memory for your installed Oracle databases. Alternatively, decrease the CPU cores if you need more CPUs assigned to your virtual machine domains. You must increase or decrease the assigned CPU core count on each node by two or multiples of two.

Oracle recommends that you use templates to size the databases that you deploy in ODA_BASE, following the guidelines in Appendix A of *Oracle Database Appliance Getting Started Guide*. Sum the number of CPUs that these databases require, using the tables in that appendix, and divide the value by two to determine the number of CPU cores that you require for ODA_BASE.

The ODA_BASE domain shuts down during the resizing process. For this reason, plan to change your ODA_BASE core count either when there is no critical activity running on your Oracle databases, or when you schedule a planned maintenance window.

4.14.2 Changing the ODA_BASE Core Count

After you have reviewed the guidelines about resizing ODA_BASE, complete these steps to change the ODA_BASE core count.

1. Log in to Dom0 and run the `oakcli configure oda_base` command as shown in this example, which changes the CPU core count from six to eight in ODA_BASE:

```
# oakcli configure oda_base
Core Licensing Options:
  1. 2 CPU Cores
```

```

2. 4 CPU Cores
3. 6 CPU Cores
4. 8 CPU Cores
5. 10 CPU Cores
6. 12 CPU Cores
Current CPU Cores      :6
Selection[1 : 6](default 12 CPU Cores) : 10
ODA base domain memory in GB(min 8, max 88)(Current Memory 64G)[default
32]      :
INFO: Using default memory size i.e. 32 GB
Additional vlan networks to be assigned to oda_base? (y/n) [n]:
Vlan network to be removed from oda_base (y/n) [n]
INFO: Node 0:Configured oda base pool
INFO: Node 1:Configured oda base pool
INFO: Node 0:ODA Base configured with new memory
INFO: Node 0:ODA Base configured with new vcpus
INFO: Changes will be incorporated after the domain is restarted on Node 0
INFO: Node 1:ODA Base configured with new memory
INFO: Node 1:ODA Base configured with new vcpus
INFO: Changes will be incorporated after the domain is restarted on Node 1

```

2. Perform any actions listed in the output from the command. Not all versions of the software, such as the one shown in the preceding example, require any additional actions before restarting ODA_BASE.
3. Restart the domain to implement the changed configuration for ODA_BASE by running the following restart command on Dom0 of both nodes:

```
oakcli restart oda_base
```

5

Oracle Appliance Manager Command Line Interface

Oracle Appliance Manager Command Line Interface (OAKCLI) is a command line interface (CLI) dedicated to Oracle Database Appliance.

Topics:

- [About the Oracle Appliance Manager Command-line Interface \(OAKCLI\)](#) (page 5-3)
The `oakcli` commands are the primary method for performing database and system administration on Oracle Database Appliance, and on Oracle Database Appliance Virtualized Platform.
- [Managing OAKCLI Privileges and Security with SUDO](#) (page 5-4)
Oracle Appliance Manager command-line utility requires `root` system privileges for most administration actions. You may want to use SUDO as part of your system auditing and security policy.
- [oakcli add disk -local](#) (page 5-6)
Use the `oakcli add disk -local` command to add a local disk to the system after physically replacing a failed disk.
- [oakcli apply](#) (page 5-7)
Use the `oakcli apply` command from Node 0 to reconfigure your Oracle Database Appliance core capacity.
- [oakcli clone commands](#) (page 5-8)
Use the `oakcli clone` commands to clone virtual machines or virtual disks.
- [oakcli configure commands](#) (page 5-11)
Use the `oakcli configure` commands to configure components on Oracle Database Appliance.
- [oakcli copy](#) (page 5-21)
Use the `oakcli copy` command to prepare a copy of the configuration file for use during the configuration of Oracle Database Appliance.
- [oakcli create commands](#) (page 5-21)
Use the `oakcli create` commands to create components on Oracle Database Appliance.
- [oakcli delete commands](#) (page 5-32)
Use the `oakcli delete` commands to delete components from Oracle Database Appliance.
- [oakcli deploy](#) (page 5-37)
Use the command `oakcli deploy` to deploy Oracle Grid Infrastructure for a cluster on Oracle Database Appliance.
- [oakcli describe-cpucore](#) (page 5-38)
Use the `oakcli describe-cpucore` command to display the current core configuration and the modification date and time.

- [oakcli expand storage](#) (page 5-39)
Use the `oakcli expand storage` command to configure the solid-state drives (SSDs) for data storage into the existing base configuration to fully populate the base storage shelf.
- [oakcli diskwritecache](#) (page 5-40)
Use the `oakcli diskwritecache` command to locate disks with write cache enabled and to disable disk write cache for those disks.
- [oakcli import vmtemplate](#) (page 5-40)
Use the `oakcli import vmtemplate` command to import virtual machine templates.
- [oakcli locate disk](#) (page 5-42)
Use the `oakcli locate disk` command to locate the physical disk that is associated with a named Oracle ASM disk by turning the disk's LED light on or off.
- [oakcli manage diagcollect](#) (page 5-42)
Use the `oakcli manage diagcollect` command to collect diagnostic information about Oracle Database Appliance for troubleshooting purposes, and for working with Oracle Support Services.
- [oakcli migrate vm](#) (page 5-43)
Use the `oakcli migrate vm` command to migrate a currently running virtual machine to another node.
- [oakcli modify commands](#) (page 5-44)
Use the `oakcli modify` commands to modify the database, an existing virtual machine or virtual machine template.
- [oakcli orachk](#) (page 5-46)
Use the `oakcli orachk` command to audit configuration settings with the ORAchK utility.
- [oakcli reconfigure osparams](#) (page 5-47)
Use the `oakcli reconfigure osparams` command to adjust the kernel parameters based on the available RAM after you upgrade memory or DIMM.
- [oakcli resize dbstorage](#) (page 5-49)
Use the `oakcli resize dbstorage` command to resize the space used for a storage structure that was created for the purpose of migrating databases from Oracle ASM to Oracle ACFS.
- [oakcli restart oda_base](#) (page 5-49)
Use the `oakcli restart oda_base` command to stop and restart ODA_BASE on the local node.
- [oakcli show commands](#) (page 5-50)
Use the `oakcli show` commands to display the status of Oracle Database Appliance components.
- [oakcli start commands](#) (page 5-70)
Use the `oakcli start` commands to start a virtual machine, to start a shared repository on a node, or to start ODA_BASE on the local node.
- [oakcli stop command](#) (page 5-72)
Use the `oakcli stop` command to stop a virtual machine, to stop a shared repository on a node, or to stop ODA_BASE on the local node.
- [oakcli stordiag](#) (page 5-73)
Use the `oakcli stordiag` command to run diagnostic tests on a disk in the storage shelf or storage expansion shelf.

- [oakcli test asr](#) (page 5-74)
Use the `oakcli test asr` command to send a test trap to determine if Oracle Auto Service Request (Oracle ASR) is configured and working correctly.
- [oakcli unpack](#) (page 5-74)
Use the `oakcli unpack` command to unpack packages into the Oracle Appliance Manager repository.
- [oakcli update](#) (page 5-75)
Use the `oakcli update` command to apply Oracle Database Appliance patches.
- [oakcli upgrade](#) (page 5-76)
Use the `oakcli upgrade` command to upgrade the Oracle Database software on Oracle Database Appliance.
- [oakcli validate](#) (page 5-77)
Validates the state of an Oracle Database Appliance or the viability of an operating system patch.

5.1 About the Oracle Appliance Manager Command-line Interface (OAKCLI)

The `oakcli` commands are the primary method for performing database and system administration on Oracle Database Appliance, and on Oracle Database Appliance Virtualized Platform.

You can perform the following tasks with OAKCLI commands:

- List the hardware components
- Validate and diagnose the hardware components
- Install and upgrade software
- Apply software patches
- Create and drop databases
- Install and uninstall Oracle Homes
- Deploy and manage virtual machines
- Test Oracle Auto Service Request (Oracle ASR)
- Enable CPU cores

Depending on your version of Oracle Appliance Manager and your hardware, some of the OAKCLI commands may not be available to you. To see which OAKCLI commands are supported on your version of Oracle Appliance Manager and your hardware, run the help command for OAKCLI: `oakcli -h`

OAKCLI Command Location and Path Configuration

The Oracle Appliance Manager command-line interface is in the following directory:

```
/opt/oracle/oak/bin/oakcli
```

Configure the `root` user account on your Oracle Database Appliance servers to have the `PATH` variable defined to search for `oakcli` commands in the path `/opt/oracle/oak/bin/oakcli`.

OAKCLI Syntax

Oracle Appliance Manager command-line interface commands and parameters are case-insensitive.

An `oakcli` command uses the following command syntax:

```
oakcli command object [options]
```

- *command* is an action you want to perform on the appliance. For example: `show`, `locate`, `apply`.
- *object* is the target or object on which the `oakcli` command performs the operation. For example, you issue a command to create or configure a disk, or a controller, or perform other system or software administration. You can also use object abbreviations.
- *options* are optional parts of the `oakcli` command. Options can consist of one or more options that extend the use of the `oakcli` command carried out on an object. Options include additional information about the action that you want to perform on the object. Option names are preceded with a dash. Many options require the name of an object for the command to perform the action that you want to carry out. The help option (`-h`) is an option that is available with every command. When you include the `-h` option, you can obtain additional information about the command that you want to perform.

Oracle Appliance Manager Command-Line Interface Help

Run the following command to see the usage information for all `oakcli` commands available for your Oracle Database Appliance:

```
oakcli -h
```

Run the following command to see detailed help about a specific `oakcli` command:

```
oakcli command -h
```

Run the following command to see detailed help about a specific `oakcli` command carried out on an object, and the options that are available for you to use with that object.

```
oakcli command object -h
```

5.2 Managing OAKCLI Privileges and Security with SUDO

Oracle Appliance Manager command-line utility requires `root` system privileges for most administration actions. You may want to use SUDO as part of your system auditing and security policy.

For most tasks, Oracle recommends that you log in as `root` to use the Oracle Appliance Manager command-line interface on Oracle Database Appliance. If you are not logged in as `root`, then you cannot carry out most actions on the appliance. For example, if you are not logged in as `root`, then you can view storage information, but you cannot modify the storage.

Allowing Root User Access Using SUDO

In environments where system administration is handled by a different group than database administration, or where security is a significant concern, you may want to limit access to the `root` user account and password. SUDO enables system administrators to grant certain users (or groups of users) the ability to run commands as `root`, while logging all commands and arguments as part of your security and compliance protocol.

A SUDO security policy is configured by using the file `/etc/sudoers`. Within the `sudoers` file, you can configure groups of users and sets of commands to simplify and audit server administration with SUDO commands.

Caution:

Configuring SUDO to allow a user to perform any operation is equivalent to giving that user `root` privileges. Consider carefully if this is appropriate for your security needs.

SUDO Example 1: Allow a User to Perform Any OAKCLI Operation

This example shows how to configure SUDO to enable a user to perform any OAKCLI operation. You do this by adding lines to the commands section in the `/etc/sudoers` file:

```
## The commands section may have other options added to it.
##
Cmnd_Alias OAKCLI_CMDS=/opt/oracle/oak/bin/oakcli *
jdoe ALL = OAKCLI_CMDS
```

In this example, the user name is `jdoe`. The file parameter setting `ALL= OAKCLI_CMDS` grants the user `jdoe` permission to run all `oakcli` commands that are defined by the command alias `OAKCLI_CMDS`. After configuration, you can copy one `sudoers` file to multiple hosts. You can also create different rules on each host.

Note:

Before database creation, you must set up user equivalency with SSH for the root user on each server. If you do not set up user equivalency and configure SSH on each server, then you are prompted to provide the root password for each server during database creation.

After you configure the `sudoer` file with the user, the user `jdoe` can run the set of `oakcli` commands configured with the command alias `OAKCLI_CMDS`. For example:

```
$ sudo oakcli create database -db newdb
```

```
INFO: 2015-08-05 14:40:55: Look at the logfile '/opt/oracle/oak/log/scaoda1011/
tools/12.1.2.4.0/createdb_newdb_91715.log' for more details
```

```
INFO: 2015-08-05 14:40:59: Database parameter file is not provided. Will be using
```

```

default parameters for DB creation
Please enter the 'SYSASM' password:
Please re-enter the 'SYSASM' password:

INFO: 2015-08-05 14:41:10: Installing a new home: OraDb12102_home3 at /u01/app/
oracle/product/12.1.0.2/dbhome_3

Please select one of the following for Database type [1 .. 3]:
1   => OLTP
2   => DSS
3   => In-Memory

```

SUDO Example 2: Allow a User to Perform Only Selected OAKCLI Operations

To configure SUDO to allow a user to perform only selected OAKCLI operations, add lines to the commands section in the `/etc/sudoers` file as follows:

```

## oakcli commands
Cmnd_Alias OAKENV = /opt/oracle/oak/bin/oakcli show env_hw
Cmnd_Alias OAKVER = /opt/oracle/oak/bin/oakcli show version
oracle ALL= OAKENV,OAKVER

```

The following are sample outputs for the commands:

```

$ sudo /opt/oracle/oak/bin/oakcli show env_hw
VM-ODA_BASE ODA X6-2-HA

$ sudo /opt/oracle/oak/bin/oakcli show version
Version
-----
12.2.1.2.0

```

In this example, the user `jdoue2` tries to run the `oakcli show databases` command, which is not part of the set of commands that is configured for that user. Sudo prevents `jdoue2` from running the command.

```

$ sudo /opt/oracle/oak/bin/oakcli show databases
Sorry, user oracle is not allowed to execute '/opt/oracle/oak/bin/oakcli show
databases' as root on servernode1.

```

5.3 oakcli add disk -local

Use the `oakcli add disk -local` command to add a local disk to the system after physically replacing a failed disk.

Syntax

```
oakcli add disk -local
```

Usage Notes

- You cannot add more than two disks per node.
- You must remove the failed drive and replace it with a new drive before running the `oakcli add disk -local` command.
- The new disk must be inserted into the slot before you run this command.
- The `oakcli add disk -local` command is supported only on bare metal deployments. It is not supported on virtualized configurations.

5.4 oakcli apply

Use the `oakcli apply` command from Node 0 to reconfigure your Oracle Database Appliance core capacity.

Syntax

Use the following syntax where `core_config_key_file` is the full path name of a configuration key file generated on My Oracle Support and copied to Oracle Database Appliance:

```
oakcli apply core_configuration_key core_config_key_file [-h]
```

Parameters

Parameter	Description
<code>core_config_key_file</code>	Identifies the full path and name of the configuration key file
<code>-h</code>	(Optional) Display help for using the command.

Usage Notes

-
- Run the `oakcli apply` command from the first node in Oracle Database Appliance as the `root` user.
- After you run the `oakcli apply` command, Oracle Database Appliance applies the key to both nodes and reboots both nodes. Run the `oakcli show core_config_key` command to view the core configuration key.
- The core key application is applicable only to bare metal implementations. It is not available on an Oracle Database Appliance Virtualized Platform.

Example 5-1 Reconfiguring Oracle Database Appliance with a New Core Count

Reconfigure Oracle Database Appliance with a new core count using the configuration key file `/tmp/set8cores.conf`:

```
oakcli apply core_configuration_key /tmp/set8cores.conf
.....done
INFO: Cluster will be rebooted after applying the core_configuration_key successfully
INFO: .....

INFO: Applying core_configuration_key on '192.0.2.21'
INFO: .....
INFO: Running as root: /usr/bin/ssh -l root 192.0.2.21 /tmp/tmp_lic_exec.pl
INFO: Running as root: /usr/bin/ssh -l root 192.0.2.21 /opt/oracle/oak/bin/oakcli
enforce core_configuration_key /tmp/.lic_file
INFO: Applying core_configuration_key on '192.0.2.20'

INFO: .....
INFO: Running as root: /usr/bin/ssh -l root 192.0.2.20 /tmp/tmp_lic_exec.pl
INFO: Running as root: /usr/bin/ssh -l root 192.0.2.20 /opt/oracle/oak/bin/oakcli
enforce core_configuration_key /tmp/.lic_file
INFO: Applying core_configuration_key on '192.0.2.20'
```

Related Topics

- [oakcli show core_config_key](#) (page 5-54)
Use the `oakcli show core_config_key` command to display information about how to deploy your Oracle Database Appliance cores.

5.5 oakcli clone commands

Use the `oakcli clone` commands to clone virtual machines or virtual disks.

Topics:

- [oakcli clone vdisk](#) (page 5-8)
Use the `oakcli clone vdisk` command to create clones of virtual disks.
- [oakcli clone vm](#) (page 5-9)
Use the `oakcli clone vm` command to create clones and snap clones of virtual machines.

5.5.1 oakcli clone vdisk

Use the `oakcli clone vdisk` command to create clones of virtual disks.

Syntax

```
oakcli clone vdisk new_vdisk_name -repo repo_name -src source_vdisk_name [-h]
```

Parameters

Parameter	Description
<i>new_vdisk_name</i>	Name given to the clone virtual disk
<i>repo_name</i>	Name of the repository source for the virtual disk being cloned
<i>source_vdisk_name</i>	Name of the virtual disk being cloned
-h	(Optional) Display help for using the command.

Usage

The virtual disk and `vm.cfg` files are stored in the following directories:

- Dom0: `/Repositories/vm_repo_name/.ACFS/snaps/vm_name/VirtualMachines/vm_name`
- ODA_BASE: `/app/sharedrepo/vm_repo_name/.ACFS/snaps/vm_name/VirtualMachines/vm_name`

Example 5-2 Cloning a Virtual Disk

Clone a virtual disk named `my_vdisk2` from an existing virtual disk named `vdisk1` that is stored in the repository named `vrep01`:

```
oakcli clone vdisk my_vdisk2 -repo vrep01 -src vdisk1
```

5.5.2 oakcli clone vm

Use the `oakcli clone vm` command to create clones and snap clones of virtual machines.

Syntax

To create a virtual machine from a template:

```
oakcli clone vm vm_name -vmtemplate template_name -repo repo_name [-node 0/1] [-driverdomain]
```

To create a snapshot clone of an existing virtual machine:

```
oakcli clone vm vm_name -vm src_vm_name -snap [-force] [-driverdomain]
```

To create a virtual machine snapshot from a template:

```
oakcli clone vm <vm_name> -vmtemplate src_vmtmpl_name -snap [-driverdomain]
```

Parameters

Parameter	Description
<code>-vm<i>vm_name</i></code>	Identifies the name given to the new cloned virtual machine.
<code>-vmtemplate <i>template_name</i></code>	Identifies the name of the template containing the virtual machine that you want to clone.
<code>-repo <i>repo_name</i></code>	Identifies the name of the repository that contains the template being cloned.
<code>-node <i>0 1</i></code>	Identifies the Oracle Database Appliance node that contains the shared repository from which the virtual machine is to be cloned.
<code>-vm <i>src_name</i></code>	Identifies the name of the virtual machine that is to be cloned.
<code>-snap</code>	(Optional) Creates a snapshot of the source virtual machine or virtual machine template.
<code>-driverdomain</code>	(Optional) Creates the virtual machine with the driver domain option. The driver domain option improves performance by enabling guest virtual machines to use ODA_BASE instead of Dom0 to access virtual disks. Newly created virtual disks are mounted directly from ODA_BASE to a guest virtual machine.
<code>-force</code>	(Optional) When cloning a source virtual machine, the <code>-force</code> option enables you to make a change from the source virtual machine. For example, if the source file does not use a driver domain, you can use <code>-force -driverdomain</code> to create a clone virtual machine that does use the driver domain.
<code>-h</code>	(Optional) Displays help for using the command.

Usage Notes

- The `-node` parameter must be used when you clone from a shared repository. The `-node` parameter is invalid for non-shared repositories.
- The virtual disk and `vm.cfg` files are stored in the following directories:

- Dom0: /Repositories/vm_repo_name/.ACFS/snaps/vm_name/
VirtualMachines/vm_name
- ODA_BASE: /app/sharedrepo/vm_repo_name/.ACFS/snaps/vm_name/
VirtualMachines/vm_name
- Live migration of driver domain virtual machines is not supported.
- The driver domain option is supported with the following guest operating systems:
 - Oracle Linux with the latest Unbreakable Enterprise Kernel 2 (UEK2), Unbreakable Enterprise Kernel 3 (UEK3), or Unbreakable Enterprise Kernel Release 4 (UEK R4).
 - Microsoft Windows with Oracle VM Windows PV Driver 3.4.1. Oracle VM Windows PV Driver 3.4.1 release is available for download on My Oracle Support as patch number 23346086.
 - Oracle Solaris 11.3 or higher x86.

- The driver domain only works when you add virtual disks to a guest virtual machine. When `-driverdomain` is specified, the cloned virtual machine is in driver domain mode. The corresponding virtual machine configuration file, `vm.cfg`, has the following disk entries:

When `-driverdomain` is specified, the cloned virtual machine is in driver domain mode. The corresponding virtual machine configuration file, `vm.cfg`, has the following disk entries:

```
disk = [u'file:/OVS/Repositories/repo5/.ACFS/snaps/vm10/  
VirtualMachines/  
vm10/System.img,xvda,w',  
u'file:/u01/app/sharedrepo/repo5/.ACFS/snaps/  
vm10/VirtualMachines/vm10/u01.img,xvdb,w,oakDom1' ]
```

All disks, with the exception of the `xvda` boot disk, have the path from `oakDom1`, that is `odabase`.

- The driver domain functionality applies to non-system disks. Once a virtual machine is created in driver domain mode, any new vDisks are added in driver domain mode.
- To determine if a virtual machine is configured in driver domain mode, use the `oakcli show vm vmname` command. When the virtual machine is in driver mode, the output for the `DriverDomain` attribute is `TRUE`.

Example 5-3 Creating a Virtual Machine Image

Create a virtual machine image named `myol6u_test` from the virtual machine template named `myol6u_15gb1`, which is stored in the shared repository named `repo2` on Node 0:

```
oakcli clone vm myol6u_test -vmtemplate myol6u_15gb1 -repo repo2 -node 0
```

Example 5-4 Creating a Virtual Machine Image in Driver Domain Mode

Create a virtual machine image named `myol6u_test` from the virtual machine template named `myol6u_15gb1`, which is stored in the shared repository named `repo2` on Node 0 in driver domain mode:

```
oakcli clone vm myol6u_test -vmtemplate myol6u_15gb1 -repo repo2 -node 0 -  
driverdomain
```

5.6 oakcli configure commands

Use the `oakcli configure` commands to configure components on Oracle Database Appliance.

- [oakcli configure additionalnet](#) (page 5-12)
Use the `oakcli configure additionalnet` command to configure any unconfigured public networks in bare metal, Domain 0, and ODA_BASE.
- [oakcli configure asr](#) (page 5-12)
Use the `oakcli configure asr` command to configure Oracle Auto Service Request (Oracle ASR) on Oracle Database Appliance.
- [oakcli configure cpupool](#) (page 5-13)
Use the `oakcli configure cpupool` command to configure a CPU pool on one Oracle Database Appliance Virtualized Platform node.
- [oakcli configure firstnet](#) (page 5-14)
Use the `oakcli configure firstnet` command to configure an initial network on Oracle Database Appliance that enables you to download deployment software.
- [oakcli configure ib2fiber](#) (page 5-14)
Run the `oakcli configure ib2fiber` command after replacing InfiniBand 10GbE SFP+ cards (fiber) cards and before deployment to unconfigure IB setup and configure fiber cards.
- [oakcli configure network](#) (page 5-15)
Use the `oakcli configure network` command to configure the network after either replacing a network card or swapping the public network from copper to fiber and vice versa. The meaning of the command changes depending on which parameter you use.
- [oakcli configure oda_base](#) (page 5-15)
Use the `oakcli configure oda_base` command to change the CPU core count assigned to ODA_BASE, add or remove virtual local area networks assigned to ODA_BASE, and adjust resource allocation among user domains and between ODA_BASE and other user domains.
- [oakcli configure repo](#) (page 5-16)
Use the `oakcli configure repo` command to increase the size of a shared repository.
- [oakcli configure vm](#) (page 5-17)
Use the `oakcli configure vm` command to configure a virtual machine on Oracle Database Appliance Virtualized Platform and to increase or decrease resource allocation to user domains.
- [oakcli configure vmtemplate](#) (page 5-19)
Use the `oakcli configure vmtemplate` command to configure a virtual machine template on Oracle Database Appliance Virtualized Platform.

5.6.1 oakcli configure additionalnet

Use the `oakcli configure additionalnet` command to configure any unconfigured public networks in bare metal, Domain 0, and ODA_BASE.

Syntax

```
oakcli configure additionalnet [-h]
```

Parameter

`-h` displays online help for using the command.

Usage Notes

The `oakcli configure additionalnet` command automatically detects any unconfigured networks and runs an interactive script that guides you through how to configure the network. The script requires the following input:

- Interface name
- DHCP [Y/N]
- IP
- Netmask

Note:

If you are running the command on a bare metal deployment, then the interface name expects a bond name. If you are running the command on Dom0, then the interface name expects a net name. If you are running the command on Dom1, then the interface name expects an eth name.

5.6.2 oakcli configure asr

Use the `oakcli configure asr` command to configure Oracle Auto Service Request (Oracle ASR) on Oracle Database Appliance.

Syntax

```
oakcli configure asr [-h]
```

Parameter

`-h` displays help for using the command.

Usage Notes

- The `oakcli configure asr` command initiates an interactive script that requests the following information to implement Oracle ASR on Oracle Database Appliance:
 - Action to be performed (setup internal, setup external, deinstall, or reconfigure Oracle ASR Manager)
 - PROXY server name, port, user ID, and password

- Oracle ASR user ID and password
- Oracle ASR Manager IP and port
- You can configure Oracle ASR on Oracle Database Appliance to use its own ASR Manager (**internal Oracle ASR**) or use Oracle ASR Manager configured on another server in the same network as your appliance (**external Oracle ASR**). If you already have Oracle ASR Manager configured in your environment, you can register Oracle Database Appliance with your existing Oracle ASR Manager.

 **Note:**

With an internal Oracle ASR Manager, an alert is not sent when the server goes down. If a critical event occurs on Oracle Database Appliance with an external Oracle ASR Manager, then an alert can still be sent to Oracle.

Configuring Oracle ASR

```
# oakcli configure asr

INFO : Logging all actions in /opt/oracle/oak/onecmd/tmp/
scaodal011-20150805153300.log and traces in /opt/oracle/oak/onecmd/tmp/
scaodal011-20150805153300.trc

Please enter
1 to setup Internal ASR
2 to setup External ASR
3 to Deinstall ASR
0 to Exit

[1]:INFO : Logging all actions in /opt/oracle/oak/onecmd/tmp/
scaodal011-20150805153300.log and traces in /opt/oracle/oak/onecmd/tmp/
scaodal011-20150805153300.trc
```

5.6.3 oakcli configure cpupool

Use the `oakcli configure cpupool` command to configure a CPU pool on one Oracle Database Appliance Virtualized Platform node.

Syntax

```
oakcli configure cpupool poolname -numcpu cpu_count -node nodenum [-h]
```

Parameters

Parameter	Description
<i>poolname</i>	Unique name for the CPU pool
-numcpu <i>cpu_count</i>	Number of CPUs for the CPU pool
-node <i>nodenum</i>	Node where the CPU pool will be created (0 or 1)
-h	(Optional) Display help for using the command.

Configuring a CPU Pool

Configure a CPU pool named `twonode` with two cores on Node 1 of Oracle Database Appliance Virtualized Platform:

```
oakcli configure cpupool twonode -numcpu 2 -node 1
```

5.6.4 oakcli configure firstnet

Use the `oakcli configure firstnet` command to configure an initial network on Oracle Database Appliance that enables you to download deployment software.

Syntax

```
oakcli configure firstnet
```

Example

The `oakcli configure firstnet` command creates an initial network on a new Oracle Database Appliance using an interactive script. The following example shows how to configure the initial network on a bare metal Oracle Database Appliance:

```
oakcli configure firstnet
Select the interface to configure network on [bond0 bond1 bond2 xbond0]:bond0
Configure DHCP on bond0?(yes/no):no
    INFO: Static configuration selected
    Enter the IP address to configure:192.0.2.18
    Enter the netmask address to configure:255.255.252.0
    Enter the gateway address to configure:192.0.2.1
Plumbing the IPs now
Restarting the network
::::::::::::::::::
```



Note:

Oracle recommends using the `oakcli configure firstnet` command only one time on Oracle Database Appliance. Subsequent use after configuring the initial network can cause unpredictable changes to your network settings.

5.6.5 oakcli configure ib2fiber

Run the `oakcli configure ib2fiber` command after replacing InfiniBand 10GbE SFP+ cards (fiber) cards and before deployment to unconfigure IB setup and configure fiber cards.



Note:

If you are using Oracle Database Appliance Virtualized Platform, then you must execute the command from Dom0.

Usage Notes

This command must be run before deployment to configure 10GbE SFP+ (fiber) cards.

Syntax

```
oakcli configure ib2fiber [-h]
```

Parameter

-h displays help for using the command.

5.6.6 oakcli configure network

Use the `oakcli configure network` command to configure the network after either replacing a network card or swapping the public network from copper to fiber and vice versa. The meaning of the command changes depending on which parameter you use.

Syntax

```
oakcli configure network [-changeNetCard|-publicNet][-h]
```

Parameters

Parameter	Description
-changeNetCard	Configures the network card after it has been replaced. You must run the <code>oakcli configure network -changeNetCard</code> command on each node if the network card was replaced. This parameter is supported on all Oracle Database Appliance hardware models. This command must be executed from Dom0 on virtualized platforms.
-publicNet	Configures the network after you have swapped the public network from copper to fiber and vice versa. You must run the <code>oakcli configure network -publicNet</code> command on each node, and this requires the stack to be down. The stack includes GI and RDBMS. If you are using Oracle Database Appliance Virtualized Platform, the virtual machines must be down. The virtual machines may need some configuration changes, especially if they are using VLANs. This parameter is supported only on Oracle Database Appliance X4-2 hardware models.
-h	(Optional) Display help for using the command.

5.6.7 oakcli configure oda_base

Use the `oakcli configure oda_base` command to change the CPU core count assigned to ODA_BASE, add or remove virtual local area networks assigned to ODA_BASE, and adjust resource allocation among user domains and between ODA_BASE and other user domains.

You must restart the domain for the resource allocation change to take effect.

Syntax

```
oakcli configure oda_base
```

Examples

Here are examples of how to use the `oakcli configure oda_base` command.

Changing the CPU Core Count in ODA_BASE

Change the CPU core count from six to eight in ODA_BASE:

```
# oakcli configure oda_base
Core Licensing Options:
  1. 2 CPU Cores
  2. 4 CPU Cores
  3. 6 CPU Cores
  4. 8 CPU Cores
  5. 10 CPU Cores
  6. 12 CPU Cores
Current CPU Cores      :6
Selection[1 : 6](default 12 CPU Cores) : 4
ODA base domain memory in GB(min 8, max 88)(Current Memory 64G)[default
32]      :
INFO: Using default memory size i.e. 32 GB
Additional vlan networks to be assigned to oda_base? (y/n) [n]:
Vlan network to be removed from oda_base (y/n) [n]
INFO: Node 0:Configured oda base pool
INFO: Node 1:Configured oda base pool
INFO: Node 0:ODA Base configured with new memory
INFO: Node 0:ODA Base configured with new vcpus
INFO: Changes will be incorporated after the domain is restarted on Node 0
INFO: Node 1:ODA Base configured with new memory
INFO: Node 1:ODA Base configured with new vcpus
INFO: Changes will be incorporated after the domain is restarted on Node 1
```

Changing the Amount of Memory Allocated to ODA_BASE

1. Log in to Dom0.
2. Execute the `oakcli configure oda_base` command and change the configuration.
3. Restart ODA_BASE.

Assigning VLANs to ODA_BASE

1. Log in to Dom0.
2. Execute the `oakcli configure oda_base` command.
3. Change the setting for `Additional vlan networks to be assigned to oda_base?` (y/n) to **y**.
4. Follow the prompts to assign additional VLANs to ODA_BASE.
5. Restart ODA_BASE.

5.6.8 oakcli configure repo

Use the `oakcli configure repo` command to increase the size of a shared repository.

Syntax

```
oakcli configure repo reponame -incsize size [M|G] [-h]
```

Parameter	Description
reponame	Name of the shared repository
size	Number that can be followed by M to define the size as megabytes or by G to define as size as gigabytes
-h	(Optional) Display help for using the command.

Increasing the Size of a Shared Repo

Increase the size of the `repol` shared repository by 2 gigabytes:

```
# oakcli configure repo repol -incsize 2G
```

Configured Shared Repo : `repol` with new size 3712.0.

5.6.9 oakcli configure vm

Use the `oakcli configure vm` command to configure a virtual machine on Oracle Database Appliance Virtualized Platform and to increase or decrease resource allocation to user domains.

You must restart the domain for the resource allocation change to take effect.

Syntax

```
oakcli configure vm name [-vcpu cpucount -maxvcpu maxcpu -cpuprio priority
-cpucap cap -memory memsize -maxmemory max_memsize -os sys -keyboard lang -mouse
mouse_type -domain dom -network netlist -autostart astart -disk disks -bootoption
bootstrap -cpupool pool -prefnode 0|1 -failover true|false][-h]
```

Parameters

Parameter	Description
name	The name assigned to the virtual machine.
-vcpu <i>cpucount</i>	Number of nodes assigned to the virtual machine. The range is 1 to 72. This number depends on your Oracle Database Appliance configuration
-maxvcpu <i>maxcpu</i>	Maximum number of CPUs that the virtual machine can consume. The range is 1 to 72. This number depends on your Oracle Database Appliance configuration.
-cpuprio <i>priority</i>	Priority for CPU usage, where larger values have higher priority. The range is 1 to 65535.
-cpucap <i>cap</i>	Percentage of a CPU the virtual machine can receive. The range is 10 to 100.
-memory <i>memsize</i>	Amount of memory given to the virtual machine: (1 to 248)G to (1to 760G) or (1 to 253952)M to (1 to 778240)M, based on RAM. The default is M.
-maxmemory <i>max_memsize</i>	Maximum amount of memory allowed for the virtual machine: (1 to 248)G to (1 to 760)G or (1-253952)M to (1-778240)M, based on RAM. The default is M.

Parameter	Description
-os <i>sys</i>	Operating system used by the virtual machine (WIN_2003, WIN_2008, WIN_7, WIN_VISTA, OTHER_WIN, OL_4, OL_5, OL_6, RHL_4, RHL_5, RHL_6, LINUX_RECOVERY, OTHER_LINUX, SOLARIS_10, SOLARIS_11, OTHER_SOLARIS, or NONE)
-keyboard <i>lang</i>	Keyboard used by virtual machine (en-us, ar, da, de, de-ch, en-gb, es, et, fi, fo, fr, fr-be, fr-ca, hr, hu, is, it, ja, lt, lv, mk, nl, n--be, no, pl, pt, pt-br, ru, sl, sv, th, or tr)
-mouse <i>mouse_type</i>	Mouse type used by the virtual machine (OS_DEFAULT, PS2_MOUSE, USB_MOUSE, or USB_TABLET)
-domain <i>dom</i>	Domain type from the following options: <ul style="list-style-type: none"> • Hardware virtualized guest (XEN_HVM) <ul style="list-style-type: none"> - The kernel or operating system is not virtualization-aware and can run unmodified. - Device drivers are emulated. • Para virtualized guest (XEN_PVM) <ul style="list-style-type: none"> - The guest is virtualization-aware and is optimized for a virtualized environment. - PV guests use generic, idealized device drivers. • Hardware virtualized guest (XEN_HVM_PV_DRIVERS) <ul style="list-style-type: none"> The PV drivers are hypervisor-aware and significantly reduce the overhead of emulated device input/output. • Hardware virtualized guest (UNKNOWN)
-network <i>netlist</i>	MAC address and list of networks used by the virtual machine
-autostart <i>astart</i>	Startup option for virtual machine (always, restore, or never)
-disk <i>disks</i>	List of disks (slot, disktype, and content) used by virtual machine
-bootoption <i>bootstrap</i>	Boot option used to bootstrap the virtual machine (PXE, DISK, or CDROM)
-cpupool <i>pool</i>	Named CPU pool assigned to the virtual machine
-prefnode 0 1	Preferred node on which the virtual machine will attempt to start (Node 0 or Node 1). This parameter is only valid for virtual machines created in shared repositories.
-failover true false	Allow (use the keyword "true") or disallow (use the keyword "false") the virtual machine to start or restart on a node other than the node defined by the -prefnode parameter. This parameter is only valid for virtual machines created in shared repositories.
-h	(Optional) Display help for using the command.

Usage Notes

- All of the parameters, except for *name*, are optional.
- You must include at least one optional parameter for the command to work.
- When you create a virtual machine, select the Processor Cap as a percentage, between 10 and 100%. The default is 100%. This value is then converted to a CPU utilization limit in the `vm.cfg` file for the virtual machine. The value set in the `vm.cfg` file limits the amount of CPU a guest is allowed to consume. If the Processor Cap is set at 100% in Oracle VM, then the value set in `vm.cfg` is 0, which means there is no limit to CPU utilization.

 **See Also:**

Oracle VM release 3.1 documentation contains more information about the options in the preceding table. Access the library at the following URL:

http://docs.oracle.com/cd/E27300_01

For example, refer to 2.8. Virtual Machines for information about the the -domain *dom* options:

http://docs.oracle.com/cd/E27300_01/E27309/html/vmusg-ovm-vms.html

Changing the Number of Virtual CPUs

This command example changes the number of virtual CPUs to 3, and changes the virtual memory size to 4 GB in a virtual machine named `odarep01`:

```
oakcli configure vm odarep01 -vcpu 3 -memory 4196
```

5.6.10 oakcli configure vmtemplate

Use the `oakcli configure vmtemplate` command to configure a virtual machine template on Oracle Database Appliance Virtualized Platform.

Syntax

```
oakcli configure vmtemplate name [-vcpu cpucount -maxvcpu maxcpu -cpuprio
priority -cpucap cap -memory memsize -maxmemory max_memsize -os sys -keyboard
lang -mouse mouse_type -domain dom -network netlist -disk disks][h]
```

Parameters

Parameter	Description
<i>name</i>	Name assigned to the virtual machine template
<code>-vcpu</code> <i>cpucount</i>	Number of nodes assigned to virtual machines cloned from the template: <ul style="list-style-type: none"> On Oracle Database Appliance X5-2, the range is from 1 to 72. On Oracle Database Appliance X4-2, the range is from 1 to 48. On Oracle Database Appliance X3-2, the range is from 1 to 32. On Oracle Database Appliance, the range is 1 to 24.
<code>-maxvcpu</code> <i>maxcpu</i>	Maximum number of CPUs that virtual machines cloned from the template can consume: <ul style="list-style-type: none"> On Oracle Database Appliance X5-2, the range is from 1 to 72. On Oracle Database Appliance X4-2, the range is from 1 to 48. On Oracle Database Appliance X3-2, the range is from 1 to 32. On Oracle Database Appliance, the range is 1 to 24.
<code>-cpuprio</code> <i>priority</i>	Priority for CPU usage, where larger values have higher priority (1 to 256).
<code>-cpucap</code> <i>cap</i>	Percentage of a CPU that virtual machines cloned from the template can receive (1 to 100).
<code>-memory</code> <i>memsize</i>	Amount of memory given to virtual machines cloned from the template (1G to 88 G or 1M to 90112M)

Parameter	Description
<code>-maxmemory</code> <code>max_memsize</code>	Maximum amount of memory allowed for virtual machines cloned from the template
<code>-os sys</code>	Operating system used by virtual machines cloned from the template (WIN_2003, WIN_2008, WIN_7, WIN_VISTA, OTHER_WIN, OL_4, OL_5, OL_6, RHL_4, RHL_5, RHL_6, LINUX_RECOVERY, OTHER_LINUX, SOLARIS_10, SOLARIS_11, OTHER_SOLARIS, or NONE)
<code>-keyboard lang</code>	Keyboard used by virtual machines cloned from the template (en-us, ar, da, de, de-ch, en-gb, es, et, fi, fo, fr, fr-be, fr-ca, hr, hu, is, it, ja, lt, lv, mk, nl, n--be, no, pl, pt, pt-br, ru, sl, sv, th, or tr)
<code>-mouse mouse_type</code>	Mouse type used by virtual machines cloned from the template (OS_DEFAULT, PS2_MOUSE, USB_MOUSE, or USB_TABLET)
<code>-domain dom</code>	Domain type from the following options: <ul style="list-style-type: none"> • Hardware virtualized guest (XEN_HVM) <ul style="list-style-type: none"> - The kernel or operating system is not virtualization-aware and can run unmodified. - Device drivers are emulated. • Para virtualized guest (XEN_PVM) <ul style="list-style-type: none"> - The guest is virtualization-aware and is optimized for a virtualized environment. - PV guests use generic, idealized device drivers. • Hardware virtualized guest (XEN_HVM_PV_DRIVERS) <ul style="list-style-type: none"> The PV drivers are hypervisor-aware and significantly reduce the overhead of emulated device input/output.
<code>-network netlist</code>	MAC address and list of networks used by virtual machines cloned from the template
<code>-disk disks</code>	List of disks (slot, disktype, and content) used by virtual machines cloned from the template
<code>-h</code>	(Optional) Display help for using the command.

Usage Notes

- All of the parameters, except for *name*, are optional.
- You must include at least one optional parameter for the command to work.



See Also:

Oracle VM Release 3.1 documentation, which is available at the following URL:

http://docs.oracle.com/cd/E27300_01 for more information about the options in the preceding table.

For example, see 2.8. Virtual Machines for details about the option `-domain dom`

http://docs.oracle.com/cd/E27300_01/E27309/html/vmusg-ovm-vms.html

Example 5-5 Configuring a VM Template

Set values for the following configuration values in the virtual machine template named `myo15u7_10gb`:

```
oakcli configure vmtemplate myo15u7_10gb
-vcpu 2 -maxvcpu 4 -cpucap 40 -memory 1536M -maxmemory 2G
-network "['type=netfront,bridge=net1']" -os OTHER_LINUX
```

- `-vcpu 2` = Two CPUs will assigned when the virtual machine starts up
- `-maxvcpu 4` = The maximum number of CPUs that can be assigned to the virtual machine is 4.
- `-cpucap 40` = The maximum percentage of a CPU's capacity that will be assigned to the virtual machine is 40%.
- `-memory 1536M` = The amount of memory assigned when the virtual machine starts up is 1536 MB.
- `-maxmemory 2G` = The maximum amount of memory that can be assigned to the virtual machine is 2 GB.
- `-network type=netfront,bridge=net1` = This is the list of networks used by virtual machines cloned from the template.
- `-os` = The operating system used by the virtual machine is OTHER_LINUX.

5.7 oakcli copy

Use the `oakcli copy` command to prepare a copy of the configuration file for use during the configuration of Oracle Database Appliance.

Syntax

```
oakcli copy -conf absolute_conf_file [-h]
```

Parameters

Parameter	Description
<code>-conf <i>absolute_conf_file</i></code>	Specifies the full path name of the configuration file
<code>-h</code>	(Optional) Display help for using the command.

Example 5-6 Preparing a Copy of the Configuration File

If you created a configuration file previously and copied this file to Oracle Database Appliance, then prepare the configuration file to be used during the configuration process. For example, if you copied the file `myserver1.conf` to `/tmp`, then enter the following command:

```
oakcli copy -conf /tmp/myserver1.conf
```

5.8 oakcli create commands

Use the `oakcli create` commands to create components on Oracle Database Appliance.

- [oakcli create cpupool](#) (page 5-22)
Use the command `oakcli create cpupool` to create a CPU pool on one Oracle Database Appliance Virtualized Platform node.
- [oakcli create database](#) (page 5-23)
Use the `oakcli create database` command to create additional databases on Oracle Database Appliance.
- [oakcli create dbhome](#) (page 5-26)
Use the `oakcli create dbhome` command to create a new database home on Oracle Database Appliance.
- [oakcli create dbstorage](#) (page 5-27)
Use the `oakcli create dbstorage` command to create a storage structure for migrating databases from Oracle ASM to Oracle ACFS.
- [oakcli create db_config_params](#) (page 5-28)
Use the `oakcli create db_config_params` command to generate a database configuration file.
- [oakcli create repo](#) (page 5-29)
Use the `oakcli create repo` command to create a new shared repository on Oracle Database Appliance Virtualized Platform.
- [oakcli create snapshotdb](#) (page 5-30)
Use the `oakcli create snapshotdb` command to create a snapshot database from an existing database.
- [oakcli create vdisk](#) (page 5-30)
Use the `oakcli create vdisk` command to create a new virtual disk in a shared repository on Oracle Database Appliance Virtualized Platform.
- [oakcli create vlan](#) (page 5-31)
Use the `oakcli create vlan` command to create a new virtual local area network (VLAN) on an Oracle Database Appliance Virtualized Platform node.

5.8.1 oakcli create cpupool

Use the command `oakcli create cpupool` to create a CPU pool on one Oracle Database Appliance Virtualized Platform node.

Syntax

```
oakcli create cpupool poolname -numcpu cpu_count -node nodenum [-h]
```

Parameters

Parameter	Description
<i>poolname</i>	Uniquely names the CPU pool
<code>-numcpu <i>cpu_count</i></code>	Defines the number of CPUs for the CPU pool
<code>-node <i>nodenum</i></code>	Defines the node where the CPU pool will be created (0 or 1)
<code>-h</code>	(Optional) Display help for using the command.

Example

Create a CPU pool with two CPUs on Node 1 of Oracle Database Appliance Virtualized Platform:

```
oakcli create cpupool twonode -numcpu 2 -node 1
```

5.8.2 oakcli create database

Use the `oakcli create database` command to create additional databases on Oracle Database Appliance.

When you run `oakcli create database`, the command prompts you for further inputs.

Note:

Do not use Oracle Database Configuration Assistant (DBCA) to create databases on Oracle Database Appliance. Only use Oracle Appliance Manager for database configuration. Deploying Oracle Database instances using Oracle Appliance Manager ensures that these databases are properly configured, optimized, and supported on Oracle Database Appliance.

Syntax

```
oakcli create database -db db_name [[[-oh home] | [-version version]] [-storage acfs] [-params params_file] [-cdb][h]
```

Parameters

Parameter	Description
<code>-cdb</code>	(Optional) Creates the database as a container database.
<code>-db <i>db_name</i></code>	Name of the database that you want to create.
<code>-oh <i>home</i></code>	(Optional) Name of an existing Oracle home to use when creating the database. By default, the command creates a new database home.
<code>-params <i>params_file</i></code>	(Optional) Name of the <code>db_config_parameter</code> configuration file. By default, Oracle Database Appliance uses the default configuration file. Use the command <code>oakcli create db_config_params</code> to create a configuration file.
<code>-storage <i>acfs</i></code>	(Optional) Creates an Oracle 12c database in Oracle Automatic Storage Management Cluster File System (Oracle ACFS).
<code>-version <i>version</i></code>	(Optional) Version of the database that you want to create. By default, Oracle Database Appliance uses the highest version that you have downloaded.
<code>-h</code>	(Optional) Display help for using the command.

Usage Notes

- Beginning with Oracle Database 12c release 1 (12.1.0.2), the default database location is Oracle Automatic Storage Management (Oracle ASM). If you prefer to use Oracle ACFS, then use the `-storage acfs` parameter to create an Oracle Database in Oracle ACFS.
- Flash cache is disabled and cannot be enabled.

- The `-oh` and the `-version` parameters are mutually exclusive. Attempting to use both in the same command will generate an error.
- When a database is created without identifying an Oracle home, a new Oracle home is created using a standard naming convention (for example, `OraDb11203_home3`). The number at the end of the name is incremented by one for each new home created with the same version number.
- When you upgrade the database, infrastructure, and Oracle Grid Infrastructure, you must specify an existing home to create a new database.
- If you try to create a database using the option `-version version` before downloading and unpacking the specific version database clone files, then the command will fail.
- You can create configuration files with the `oakcli create db_config_params` command.
- The prompt "Do you want to keep the data files on FLASH storage: [Y | N]" is only shown if you choose the OLTP database type and if there is some free space available on flash storage.

Examples

This section shows different scenarios for using the command `oakcli create database`.

Creating a New Database Showing Prompts

When you run `oakcli create database`, you are prompted for several inputs. The options listed for each input depend on the platform on which you run the command. For example, Database Class options 9 and 10 are available on Oracle Database Appliance X5-2.

The following command creates a database named `mydb` using an existing Oracle home named `OraDb12102_home1`:

```
oakcli create database -db mydb -oh OraDb12102_home1

Please enter the 'root' password : password
Please re-enter the 'root' password: password

Please enter the 'oracle' password : password
Please re-enter the 'oracle' password: password

Please enter the 'SYSASM' password : password
Please re-enter the 'SYSASM' password: password
Please select one of the following for Database Deployment [1 .. 3]:
1   => OLTP
2   => DSS
3   => In-Memory
1
Selected value is : OLTP
Please select one of the following for Database Deployment [1 .. 3]:
1   => EE : Enterprise Edition
2   => RACONE
3   => RAC
3
Selected value is : RAC

Do you want to keep the data files on FLASH storage: [ Y | N ]?N
```

Specify the Database Class (1. odb-01 '1 core, 8 GB memory' 2. Others) [1]:2

```
Please select one of the following for Database Class [1 .. 10]:
1 => odb-01s ( 1 cores , 4 GB memory)
2 => odb-01 ( 1 cores , 8 GB memory)
3 => odb-02 ( 2 cores , 16 GB memory)
4 => odb-04 ( 4 cores , 32 GB memory)
5 => odb-06 ( 6 cores , 48 GB memory)
6 => odb-12 ( 12 cores , 96 GB memory)
7 => odb-16 ( 16 cores , 128 GB memory)
8 => odb-24 ( 24 cores , 192 GB memory)
9 => odb-32 ( 32 cores , 256 GB memory)
10 => odb-36 ( 36 cores , 256 GB memory)
```

Creating a New Database in an Existing Oracle Home

Create a database called `sales1` in `OraDb11203_home2`:

```
oakcli create database -db sales1 -oh OraDb11203_home2
```

Creating a New Database from a Template

Create a database called `sales2` from the `salesdbtemplate.bconf` file (by appending the default file extension to the file name provided). This example also creates a new Oracle home:

```
oakcli create database -db sales2 -params salesdbtemplate
```

Creating a New Database as a Container Database

Create a version 12.1.0.2 container database called `sales3`:

```
oakcli create database -db sales3 -version 12.1.0.2 -cdb
```

Creating a Database in Oracle ACFS

You can create a database called `sales4` in Oracle 12c database in Oracle ACFS:

```
oakcli create database -db sales4 -version 12.1.0.2 -storage acfs
```

Creating an Enterprise Edition Database

Create a version 12.1.0.2 database named `DBPROD` from the database configuration file named `dbprodconf`:

```
oakcli create database -db DBPROD -version 12.1.0.2 -params dbprodconf
```

The `oakcli create database` command starts a wizard that requires some basic inputs such as the root, oracle and SYSASM password. After you enter the password information, specify the type of database and running node:

```
Please select one of the following for Database Deployment [1 .. 3]:
Selected value is: ODADBI2-base
```

```
1 => EE : Enterprise Edition
2 => RACONE
3 => RAC1
```

```
Selected value is: EE
```

```
Please select one of the following
```



```

for Node Number [1 .. 2]:

1 => ODADBI1-base
2 => ODADBI2-base2

Selected value is: ODADBI2-base

Specify the Database Class (1. Medium 2. Others) [1]:2Please select one of the
following for

Database Class [1 .. 8] :
1  => odb-01s (1 cores , 4 GB memory)
2  => odb-01  (1 cores , 8 GB memory)
3  => odb-02  (2 cores , 16 GB memory)
4  => odb-04  (4 cores , 32 GB memory)
5  => odb-06  (6 cores , 48 GB memory)
6  => odb-12  (12 cores, 96 GB memory)
7  => odb-16  (16 cores, 128 GB memory)
8  => odb-24  (24 cores, 192 GB memory)
9  => odb-32  (32 cores, 256 GB memory)
10 => odb-36  (36 cores, 256 GB memory)

3
Selected value is: 2 cores

```

**Note:**

The database class only defines the Oracle Database Configuration Assistant (DBCA) template to be used for the database creation. Oracle Database Appliance comes with a specific number of templates and none can be added. See [Database Templates for Oracle Database Appliance](#) (page B-1) for template specifications.

5.8.3 oakcli create dbhome

Use the `oakcli create dbhome` command to create a new database home on Oracle Database Appliance.

Syntax

```
oakcli create dbhome [-version version] [-h]
```

Parameters

Parameter	Description
<code>-version <i>version</i></code>	(Optional) Version that you want to install. If this is not provided, then Oracle Database Appliance uses the latest available version.
<code>-h</code>	(Optional) Display help for using the command.

Creating a Database Home

Create a database home called `sales1` using Oracle Database version 12.1.0.2.4.

```
oakcli create dbhome -version 12.1.0.2.4
```

5.8.4 oakcli create dbstorage

Use the `oakcli create dbstorage` command to create a storage structure for migrating databases from Oracle ASM to Oracle ACFS.

Syntax

```
oakcli create dbstorage -db db_name [-cdb][-h]
```

Parameters

Parameter	Description
-db <i>db_name</i>	Sets up the required Oracle ACFS storage structure for the database to be created called <i>db_name</i>
-cdb	Must be passed if you are creating a multitenant container database
-h	(Optional) Display help for using the command.

Example

The `oakcli create dbstorage` command requests user input to determine the size of the storage structure to create, as shown in this example:

```
oakcli create dbstorage -db sales

Please enter the 'root' password :
Please re-enter the 'root' password:

Please enter the 'oracle' password :
Please re-enter the 'oracle' password:

Please enter the 'SYSASM' password:
Please re-enter the 'SYSASM' password:

Specify the Database Class (1. odb-01 '1 core, 8 GB memory' 2. Others) [1]:2

Please select one of the following for Database Class [1 .. 8] :
1 => odb-01s ( 1 cores , 4 GB memory)
2 => odb-01 ( 1 cores , 8 GB memory)
3 => odb-02 ( 2 cores , 16 GB memory)
4 => odb-04 ( 4 cores , 32 GB memory)
5 => odb-06 ( 6 cores , 48 GB memory)
6 => odb-12 ( 12 cores , 96 GB memory)
7 => odb-16 ( 16 cores , 128 GB memory)
8 => odb-24 ( 24 cores , 192 GB memory)

Selected value is: odb-01s ( 1 cores , 4 GB memory)
...
```

5.8.5 oakcli create db_config_params

Use the `oakcli create db_config_params` command to generate a database configuration file.

The configuration file is created in `/opt/oracle/oak/install/dbconf` and is given the default extension `.dbconf`.

Syntax

```
oakcli create db_config_params -conf filename [-h]
```

Parameters

Parameter	Description
<code>-conf filename</code>	Name you want to give to the configuration file, without its path name.
<code>-h</code>	(Optional) Display help for using the command

Example

Create the database parameter file: `/opt/oracle/oak/install/dbconf/newconf.dbconf`:

```
# oakcli create db_config_params -conf newconf
```

```
Please select one of the following for Database Block Size [1 .. 4]:
```

```
1 ==> 4096
```

```
2 ==> 8192
```

```
3 ==> 16384
```

```
4 ==> 32768
```

```
2
```

```
Selected value is: 8192
```

```
Specify the Database Language (1. AMERICAN 2. Others) [1]:
```

```
Selected value is: AMERICAN
```

```
Specify the Database Characterset (1. AL32UTF8 2. Others) [1]:2
```

```
Please select one of the following for Database Characterset [0 .. 10] :
```

```
0 => Others
```

```
1 => AL32UTF8
```

```
2 => AR8ADOS710
```

```
3 => AR8ADOS710T
```

```
4 => AR8ADOS720
```

```
5 => AR8ADOS720T
```

```
6 => AR8APTEC715
```

```
7 => AR8APTEC715T
```

```
8 => AR8ARABICMACS
```

```
9 => AR8ASMO708PLUS
```

```
10 => AR8ASMO8X
```

```
1
```

```
Selected value is: AL32UTF8
```

```
Specify the Database Territory (1. AMERICA 2. Others) [1]:2
```

```
Please select one of the following for Database Territory [0 .. 10] :
```

```
0 => Others
```

```

1 => ALBANIA
2 => ALGERIA
3 => AMERICA
4 => ARGENTINA
5 => AUSTRALIA
6 => AUSTRIA
7 => AZERBAIJAN
8 => BAHRAIN
9 => BANGLADESH
10 => BELARUS
3
Selected value is: AMERICA

Specify the Component Language (1. en 2. Others) [1]:2

Please select one of the following for Component Language [0 .. 10] :
0 => Others
1 => en : English
2 => fr : French
3 => ar : Arabic
4 => bn : Bengali
5 => pt_BR : Brazilian Portuguese
6 => bg : Bulgarian
7 => fr_CA : Canadian French
8 => ca : Catalan
9 => hr : Croatian
10 => cs : Czech
1
Selected value is: en
Successfully generated the Database parameter file 'newconf'

```

5.8.6 oakcli create repo

Use the `oakcli create repo` command to create a new shared repository on Oracle Database Appliance Virtualized Platform.

Syntax

```
oakcli create repo repo_name -size size [M|G] -dg DATA|RECO [-h]
```

Parameters

Parameter	Description
<i>repo_name</i>	Name assigned to the shared repository
-size <i>size</i> [M G]	Amount of storage to be assigned to the shared repository. It can be defined in megabytes with the M option or in gigabytes with the G option.
-dg DATA RECO	Oracle ASM disk group in which the shared repository is to be stored, either the DATA+ disk group or the RECO+ disk group, selected by using the DATA or RECO option respectively
-h	(Optional) Display help for using the command.

Usage Notes

- The `-size` parameter requires a whole number for size.

- The minimum value for *size* is 500 when M is used or 1 when G is used for the sizing unit.
- The default unit for *size* is G (gigabytes).
- A shared repository should only be used for the virtual machine and not as a file staging area. Avoid copying or moving files into a shared repository.

Example

Create a 25-gigabyte shared repository named `repoprod1` in the DATA+ disk group:

```
oakcli create repo repoprod1 -dg DATA -size 25
```

5.8.7 oakcli create snapshotdb

Use the `oakcli create snapshotdb` command to create a snapshot database from an existing database.

Syntax

```
oakcli create snapshotdb [-db snap_dbname -from dbname] | [-h]
```

Parameters

Parameter	Description
<code>-db <i>snap_dbname</i></code>	Name of the snapshot database to be created
<code>-from <i>source_dbname</i></code>	Name of the source database
<code>-h</code>	(Optional) Display help for using the command

Example

Create a new snapshot database, name `snapprod`, from the database named `prod`:

```
oakcli create snapshotdb -db snapprod -from prod
```

5.8.8 oakcli create vdisk

Use the `oakcli create vdisk` command to create a new virtual disk in a shared repository on Oracle Database Appliance Virtualized Platform.

Syntax

```
oakcli create vdisk vdisk_name -repo repository_name -size size -type shared|local -sparse [-h]
```

Parameters

Parameter	Description
<code><i>vdisk_name</i></code>	Name assigned to the virtual disk that is unique within the name repository
<code>-repo <i>repository_name</i></code>	Name of the shared repository where the virtual disk will be created and from which it will acquire its storage

Parameter	Description
<code>-size size</code>	Amount of storage to be assigned from the shared repository to the shared disk. The default unit is G (for gigabytes) and the minimum size is 500 M (for megabytes)
<code>-type shared local</code>	Sets the option of allowing the virtual disk to be shared by more than one virtual machine (<code>shared</code>) or used by only one virtual machine (<code>local</code>)
<code>-sparse</code>	Creates a sparse vdisk
<code>-h</code>	(Optional) Display help for using the command.

Example

Create a virtual disk named `t2g` in the shared repository named `repoprod1` for use by only one virtual machine at a time in that repository. Assign the `t2g` virtual disk 2 GB in the `repoprod1` shared repository.

```
oakcli create vdisk t2g -repo repoprod1 -type local -size 2G
```

5.8.9 oakcli create vlan

Use the `oakcli create vlan` command to create a new virtual local area network (VLAN) on an Oracle Database Appliance Virtualized Platform node.

Syntax

```
oakcli create vlan vlan_name -vlanid tag_id -if interface_name -node 0|1 [-h]
```

Parameters

Parameter	Description
<code>vlan_name</code>	Name assigned to the VLAN.
<code>-vlanid tag_id</code>	Tag number, used for packet routing, from 2 to 4096 inclusive. It uniquely identifies the VLAN on a node. You assign the ID and you can use the same tag number on both nodes.
<code>-if interface_name</code>	Name of the interface on which the VLAN network is created
<code>-node 0 1</code>	Node on which the VLAN is created, either Node0 or Node1.
<code>-h</code>	(Optional) Display help for using the command.

Usage Notes

- You can assign VLANs to ODA_BASE during the deployment.
- The VLAN for the ODA_BASE is created from DOM-0.
- Only execute the VLAN created in Dom-0 from Node0.
- VLAN creation in dom0 should be executed only from Node 0.

Examples

Here are examples of how to use the `oakcli create vlan` command.

Creating a New VLAN

Create a VLAN named `sample10` on Node 1 using the `bond1` interface and a tag with the number 10:

```
oakcli create vlan sample10 -vlanid 10 -if bond1 -node 1
```

Duplicating a VLAN on the Second Node

Create a VLAN named `sample10` on Node 0:

```
oakcli create vlan sample10 -vlanid 10 -if bond1 -node 0
```

5.9 oakcli delete commands

Use the `oakcli delete` commands to delete components from Oracle Database Appliance.

- [oakcli delete cpupool](#) (page 5-33)
Use the `oakcli delete cpupool` command to delete a CPU pool from one Oracle Database Appliance Virtualized Platform node.
- [oakcli delete database](#) (page 5-33)
Use the `oakcli delete database` command to delete a database from Oracle Database Appliance.
- [oakcli delete db_config_params](#) (page 5-33)
Use the `oakcli delete db_config_params` command to delete a database configuration file.
- [oakcli delete dbhome](#) (page 5-34)
Use the `oakcli delete dbhome` command to delete a database home from Oracle Database Appliance.
- [oakcli delete dbstorage](#) (page 5-34)
Use the `oakcli delete dbstorage` command to delete a storage structure that was created for the purpose of migrating databases from Oracle ASM to Oracle ACFS.
- [oakcli delete repo](#) (page 5-35)
Use the `oakcli delete repo` command to delete a shared repository.
- [oakcli delete vdisk](#) (page 5-35)
Use the `oakcli delete vdisk` command to delete a virtual disk from a shared repository on Oracle Database Appliance Virtualized Platform.
- [oakcli delete vlan](#) (page 5-36)
Use the `oakcli delete vlan` command to delete a virtual local area network.
- [oakcli delete vm](#) (page 5-36)
Use the `oakcli delete vm` command to delete a virtual machine.
- [oakcli delete vmtemplate](#) (page 5-36)
Use the `oakcli delete vmtemplate` command to delete a virtual machine template.

5.9.1 oakcli delete cpupool

Use the `oakcli delete cpupool` command to delete a CPU pool from one Oracle Database Appliance Virtualized Platform node.

Syntax

```
oakcli delete cpupool poolname -node nodenum [-h]
```

Parameters

Parameter	Description
<i>poolname</i>	Name of the CPU pool to be deleted
-node <i>nodenum</i>	Node from which the CPU pool will be deleted (0 or 1)
-h	(Optional) Display help for using the command.

Example

Delete the CPU pool named *twonode* from Node 1 of Oracle Database Appliance Virtualized Platform:

```
oakcli delete cpupool twonode -node 1
```

5.9.2 oakcli delete database

Use the `oakcli delete database` command to delete a database from Oracle Database Appliance.

Syntax

```
oakcli delete database -db db_name [-h]
```

Parameters

Parameter	Description
<i>db_name</i>	Name of the database that you want to delete
-h	(Optional) Display help for using the command

Example

Delete the database named *sales1*:

```
oakcli delete database -db sales1
```

5.9.3 oakcli delete db_config_params

Use the `oakcli delete db_config_params` command to delete a database configuration file.

Syntax

```
oakcli delete db_config_params -conf filename [-h]
```

Parameters

Parameter	Description
<code>-conffilename</code>	Name of the configuration file that you want to remove, without its path name
<code>-h</code>	(Optional) Display help for using the command

5.9.4 oakcli delete dbhome

Use the `oakcli delete dbhome` command to delete a database home from Oracle Database Appliance.

Syntax

```
oakcli delete dbhome -oh oracle_home [-h]
```

Parameters

Parameter	Description
<code>-oh <i>oracle_home</i></code>	The database home to be uninstalled
<code>-h</code>	(Optional) Display help for using the command.

Example

Delete a database home called `ora11_1`:

```
oakcli delete dbhome -oh ora11_1
```

5.9.5 oakcli delete dbstorage

Use the `oakcli delete dbstorage` command to delete a storage structure that was created for the purpose of migrating databases from Oracle ASM to Oracle ACFS.

For example, run this command if you created a storage structure using `create dbstorage` that is no longer required.

Syntax

```
oakcli delete dbstorage -db db_name [-cdb] [-h]
```

Parameters

Parameter	Description
<code>db <i>db_name</i></code>	Name of the database structure to be deleted
<code>-cdb</code>	Must be passed if you are deleting a multitenant container database
<code>-h</code>	(Optional) Display help for using the command

Example

Delete the `sales` storage structure:

```
oakcli delete dbstorage -db sales
```

5.9.6 oakcli delete repo

Use the `oakcli delete repo` command to delete a shared repository.

Syntax

```
oakcli delete repo repository_name [-h]
```

Parameter

Parameter	Description
<i>repository_name</i>	The name of the shared repository to be deleted
-h	(Optional) Display help for using the command.

Example

Delete the `testrepo01` shared repository:

```
oakcli delete repo testrepo01
```

The command will not succeed if `testrepo01` is active on one or both nodes.

5.9.7 oakcli delete vdisk

Use the `oakcli delete vdisk` command to delete a virtual disk from a shared repository on Oracle Database Appliance Virtualized Platform.

Syntax

```
oakcli delete vdisk vdisk_name -repo repository_name [-h]
```

Parameters

Parameter	Description
<i>vdisk_name</i>	Name assigned to the virtual disk
-repo <i>repository_name</i>	Name of the shared repository where the virtual disk was created
-h	(Optional) Display help for using the command.

Example

Remove a virtual disk named `t2g` from the shared repository named `repoprod1`:

```
oakcli delete vdisk t2g -repo repoprod1
```

5.9.8 oakcli delete vlan

Use the `oakcli delete vlan` command to delete a virtual local area network.

Syntax

```
oakcli delete vlan vlan_name -node node_number [-h]
```

Parameters

Parameter	Description
<code>vlan <i>vlan_name</i></code>	Name of the virtual local area network to be deleted
<code>-node <i>node_number</i></code>	Oracle Database Appliance node from which you want to remove the virtual local area network
<code>-h</code>	(Optional) Display help for using the command.

Example

Delete the `sample1` virtual local area network from Node 1:

```
oakcli delete vlan sample1 -node 1
```

5.9.9 oakcli delete vm

Use the `oakcli delete vm` command to delete a virtual machine.

Syntax

```
oakcli delete vm vm_name [-server node_number] [-h]
```

Parameters

Parameter	Description
<code>vm <i>vm_name</i></code>	(Optional) Name of the virtual machine to be deleted
<code>-server <i>node_number</i></code>	(Optional) Oracle Database Appliance node from which you want to remove the virtual machine. If this optional parameter is not included, then the virtual machine is removed from both nodes.
<code>-h</code>	(Optional) Display help for using the command.

Example

Delete the `ovu22` virtual machine from Node 1:

```
oakcli delete vm ovu22 -server 1
```

5.9.10 oakcli delete vmtemplate

Use the `oakcli delete vmtemplate` command to delete a virtual machine template.

Syntax

```
oakcli delete vmtemplate template_name [-server=node_number][-h]
```

Parameters

Parameter	Description
<i>template_name</i>	Name of the virtual machine template to be removed
-server <i>node_number</i>	(Optional) Oracle Database Appliance node from which you want to remove the virtual machine template. If this optional parameter is not included, then the virtual machine template is removed from both nodes.
-h	(Optional) Display help for using the command.

Example

Delete the `ovu22` virtual machine template from both nodes:

```
oakcli delete vmtemplate ovu22
```

5.10 oakcli deploy

Use the command `oakcli deploy` to deploy Oracle Grid Infrastructure for a cluster on Oracle Database Appliance.

Syntax

```
oakcli deploy [-config] [-conf config_file] [-advance][-h]
```

Parameters

Parameter	Description
-config	(Optional) Run the Oracle Appliance Manager Configurator.
-conf <i>config_file</i>	(Optional) Preload the configuration stored in the named configuration file, <i>config_file</i> .
-advance	(Optional) Perform the deployment, or run the Oracle Appliance Manager Configurator, in advance mode. Use this option to launch Oracle Appliance Manager and change the default user ID or group user ID.
-h	(Optional) Display help for using the command.

Usage Notes

When defining the user ID and the group ID, it is a best practice to use different values.

Examples

Use these examples to understand how to use the command `oakcli deploy`.

Example 5-7 Deploying the Complete Oracle Database Appliance

```
oakcli deploy
```

Example 5-8 Running the Configurator

```
oakcli deploy -config
```

Example 5-9 Running the Offline Configurator with Advance Mode

To run the offline Configurator with advance mode, update the `config.sh` file and add `-advance`.

```
cat config.sh #!/bin/sh java -Djava.util.logging.config.file=onecommand.properties -
jar onecommand.jar config -advance run ./config.sh
```

Example 5-10 Preloading an Existing Configuration File

Preload the configuration stored in the configuration file `MYCONFIG-VM`:

```
oakcli deploy -conf myconfig -vm_file
```

Example 5-11 Changing a User Group Name or ID

You can change the following group user names or IDs on the User Group Information page: GI User, DB User, Install Group, DBA Group, DBA Oper Group, ASM DBA Group, ASM Oper Group, and ASM Admin Group.

1. Run the Configurator or Offline Configurator in `-advance` mode.
2. Select **Custom** to display the User Group Information page.
3. Change the group name or ID, then click **Next**.
4. Click **Finish**.

Example 5-12 Viewing the Log File

The command `oakcli deploy` creates a log file that is prepended with the character string `STEP*`. The log file is stored in the following location:

```
/opt/oracle/oak/onecmd/tmp/
```

5.11 oakcli describe-cpucore

Use the `oakcli describe-cpucore` command to display the current core configuration and the modification date and time.

File Path

```
$ORACLE_HOME/opt/oracle/dcs/bin/oakcli
```

Syntax

```
oakcli describe-cpucore [-h]
```

Parameters

Parameter	Description
<code>--help, -h</code>	(Optional) Displays help for using the command.

Usage Notes

This command applies only to bare metal deployments. It is not available on an Oracle Database Appliance Virtualized Platform.

Example 5-13 Displaying the Current Core Configuration

```
# oakcli describe-cpucore
```

Node	Cores	Modified	Job Status
0	8	November 5, 2016 9:39:59 AM SGT	Configured

5.12 oakcli expand storage

Use the `oakcli expand storage` command to configure the solid-state drives (SSDs) for data storage into the existing base configuration to fully populate the base storage shelf.

File Path

```
$ORACLE_HOME/opt/oracle/oak/bin/oakcli
```

Syntax

```
oakcli expand storage [-h]
```

Parameters

Parameter	Description
-h	(Optional) Display help for using the command.

Usage Notes

After all disks are inserted into the slots, execute the `oakcli expand storage` command on both nodes. First on the master node and then wait for 30 seconds and execute from the slave nodes. It takes about 10 to 12 minutes to add all of the disks.

Review the procedure for how to add the storage shelf for detailed steps on how to add the disks, the timing needed to avoid flooding disk events, and the steps to validate that all disks are online and are in a good state.

Example 5-14 Expanding Storage

```
#oakcli expand storage
```

```
Precheck passed.
Successfully formatted 1.6TB SSD disks...
Check the progress of expansion of storage by executing 'oakcli show disk'
Waiting for expansion to finish ...
```

Related Topics

- [Preparing for a Storage Upgrade](#) (page 3-2)
Review and perform these best practices before adding storage to the base shelf or adding the expansion shelf.

5.13 oakcli diskwritecache

Use the `oakcli diskwritecache` command to locate disks with write cache enabled and to disable disk write cache for those disks.

Enabled write caches should be disabled as soon as downtime for Oracle Database Appliance can be scheduled. During the downtime, use this command with the `disable` option for each disk, in turn, that has an enabled write cache.

Syntax

```
oakcli diskwritecache [disable disk_name | enable disk_name | status ] [-h]
```

Parameters

Parameter	Description
<code>disable <i>disk_name</i></code>	(Optional) Disable disk write cache for named disk.
<code>enable <i>disk_name</i></code>	(Optional) Enable disk write cache for named disk.
<code>status</code>	(Optional) Show the write cache status of all disks.
<code>-h</code>	(Optional) Display help for using the command.

Example 5-15 Displaying the Write Cache Status of Disks

Show the write cache status of all disks:

```
oakcli diskwritecache status
```

5.14 oakcli import vmtemplate

Use the `oakcli import vmtemplate` command to import virtual machine templates.

Syntax

```
oakcli import vmtemplate vmtemplatename -files image_files | -assembly assembly_file  
-repo repo_name [- node 0 | 1 ] [-h]
```

Parameters

Parameter	Description
<code><i>vmtemplatename</i></code>	Name that you want to assign to the template
<code>-files</code>	Use the <code>-files</code> option when importing one or more files that comprise a template.
<code><i>image_files</i></code>	<code><i>image_files</i></code> is one of the following: <ul style="list-style-type: none"> • A single template file name • A comma-separated list of files that comprise a single template • A URL enclosed in single quotation marks that links to a template file
<code>-assembly</code>	Use the <code>-assembly</code> option when importing an assembly file.

Parameter	Description
<i>assembly_file</i>	An assembly file, or a URL enclosed in single quotation marks, that links to an assembly file
<i>repo_name</i>	Name of the repository to store the template or templates that you are importing
-node	When you are importing to a shared repository, use the -node option with a value of 0 or 1 to identify the node.
-h	(Optional) Display help for using the command.

Usage Notes

- Include only one of the options, -files or -assembly, each time you run this command. You cannot include both of these options in the same statement.
- If the command imports more than one template from an assembly, then each template will automatically be given a unique name. These template names will include the name given in the `vmtemplate vmtemplatename` clause followed by a sequence number, such as `vmtemplatename1`, `vmtemplatename2`, and `vmtemplatename3`.
- When importing into a shared repository, you must include the -node option with a valid node number, 0 or 1. Using the -node option for imports into non-shared repositories will cause the command to fail.

Examples

Here are examples of how to use the `oakcli import vmtemplate` command.

Example 5-16 Importing a Virtual Machine Template from Dom0

Import the required template (`OVM_OL5U7_X86_64_PVM_10GB.tgz`) from the `/OVS` directory in Dom0 into the `odarepo1` repository and name the template file `OL5U7`:

```
oakcli import vmtemplate OL5U7 -files /OVS/OVM_OL5U7_X86_64_PVM_10GB.tgz -repo
odarepo1
```

Example 5-17 Importing a Virtual Machine Template from a Remote Server

Import a template from a remote server using a URL to identify the server and the template file:

```
oakcli import vmtemplate OL5U6 -files 'http://example.com/vm-template/OEL-5/
OVM_OL5U6_X86_64_PVM_10GB.tgz' -repo odarepo2
```

Example 5-18 Importing Virtual Machine Templates from an Assembly on a Remote Server

Import the templates contained in the assembly file stored on a remote server at the URL provided into the `odarepo1` repository:

```
oakcli import vmtemplate OL6U1 -assembly 'http://example.com/assemblies/OEL6/
OVM_OL6U1_x86_PVHVM.ova' -repo odarepo1
```

Example 5-19 Importing Virtual Machine Templates Into a Shared Repository From an Assembly on a Remote Server

Import the templates contained in the assembly file stored on a remote server at the URL provided into a shared repository named `repo4` on Node 1:

```
oakcli import vmtemplate OL6U1 -assembly 'http://example.com/assemblies/OEL6/
OVM_OL6U1_x86_PVHVM.ova' -repo repo4 -node 1
```

5.15 oakcli locate disk

Use the `oakcli locate disk` command to locate the physical disk that is associated with a named Oracle ASM disk by turning the disk's LED light on or off.

Syntax

```
oakcli locate disk diskname [on|off][-h]
```

Parameters

Parameter	Description
<i>diskname</i>	Name of the Oracle ASM disk to locate
on	(Optional) Turns on the LED of the named disk
off	(Optional) Turns off the LED of the named disk
-h	(Optional) Display help for using the command.

Example 5-20 Locating an Oracle ASM Disk by Turning on the Disk's LED

Turn on the LED of the Oracle ASM disk named `disk pd_23`:

```
oakcli locate disk pd_23 on
```

5.16 oakcli manage diagcollect

Use the `oakcli manage diagcollect` command to collect diagnostic information about Oracle Database Appliance for troubleshooting purposes, and for working with Oracle Support Services.

Syntax

```
oakcli manage diagcollect [--all | --crs [--crshome crs_home_dir]
(continued)
[--core] | --install | --chmos [--incidenttime time] [--incidentduration time]
(continued)
|--adr adr_location [--afterdate date]
(continued)
[--aftertime time] [--beforetime time] ]
[excl comp1,comp2,...] [--clean] [--storage][-h]
```

Parameters

Parameter	Description
--all	Collect all of the diagnostic information excluding Automatic Diagnostic Repository (ADR) and Cluster Health Monitor. This is the default option.
--crs	Collect Oracle Clusterware diagnostic information.
--crshome <i>crs_home_dir</i>	Specifies the location of the Oracle Clusterware home directory

Parameter	Description
<code>--core</code>	Package core files with the Oracle Clusterware diagnostic data.
<code>--install</code>	Collect the installation logs when the installation failed before running the script <code>root.sh</code> .
<code>--adr <i>adr_location</i></code>	Collect diagnostic information for ADR, where <i>adr_location</i> specifies the location of the ADR information.
<code>--afterdate <i>date</i></code>	Collect archives from the specified date. Specify the date in the <code>mm/dd/yyyy</code> format.
<code>--aftertime <i>time</i></code>	Collect the archives after the specified time. Enter the time using the format <code>YYYYMMDDHHMMSS24</code> . Supported only with the <code>-adr</code> parameter.
<code>--beforetime <i>time</i></code>	Collect the archives before the specified time. Enter the time using the format: <code>YYYYMMDDHHMMSS24</code> . Supported only the with the <code>-adr</code> parameter.
<code>--chmos</code>	Collect Cluster Health Monitor data.
<code>--incidenttime <i>time</i></code>	Collect Cluster Health Monitor data from the specified time. Enter the time using the format: <code>YYYYMMDDHHMMSS24</code> . If you do not use the <code>--incidenttime</code> parameter, then the command collects data for the past 24 hours.
<code>--incidentduration <i>time</i></code>	Collect Cluster Health Monitor data for the duration after the specified time. Enter the time using the format: <code>HH:MM</code> . If you do not specify a duration, then the command collects all Cluster Health Monitor data after the specified incident time.
<code>--excl [<i>comp1,comp2...</i>]</code>	Exclude the specified component logs. Valid components are: <code>acfs</code> , <code>inv</code> , <code>sys</code> , <code>ocr</code> , <code>crs</code> , <code>home</code> , and <code>base</code> .
<code>--clean</code>	Remove the diagnosability information gathered by this command.
<code>--storage</code>	Collect all of the logs for any storage issues. The logs can be used when you are experiencing any problems with storage and need support to diagnose the logs.
<code>--h</code>	(Optional) Display help for using the command.

5.17 oakcli migrate vm

Use the `oakcli migrate vm` command to migrate a currently running virtual machine to another node.

Syntax

```
oakcli migrate vm vmname [-h]
```

Parameters

Parameter	Description
<i>vmname</i>	Name of the virtual machine to be migrated
<code>-h</code>	(Optional) Display help for using the command.

5.18 oakcli modify commands

Use the `oakcli modify` commands to modify the database, an existing virtual machine or virtual machine template.

You can use `oakcli modify` to modify databases, attach virtual disks to or detach virtual disks from virtual machines, transmit first-boot installation configuration messages to virtual machines, and to assign networks to or delete networks from virtual machines and virtual machine templates.

Topics:

- [oakcli modify database](#) (page 5-44)
Use the `oakcli modify database` command to modify the database type or size class for a named database.
- [oakcli modify vm](#) (page 5-45)
Use the `oakcli modify vm` command to modify an existing virtual machine.
- [oakcli modify vmtemplate](#) (page 5-46)
Use the `oakcli modify vmtemplate` command to add networks to or delete networks from an existing virtual machine template.

5.18.1 oakcli modify database

Use the `oakcli modify database` command to modify the database type or size class for a named database.

Syntax

```
oakcli modify database -db db name [-dbtypeOLTP|DSS|in-Memory] [-to dbSizeclass]
```

Parameters

Parameter	Description
<code>-db <i>db-name</i></code>	Identifies the database being modified.
<code>-dbtype <i>OLTP DSS in-Memory</i></code>	(Optional) Changes the database type. The parameter <code>dbtype</code> takes one of the following three options: <ul style="list-style-type: none"> • <code>OLTP</code>: Online transaction processing • <code>DSS</code>: Decision support system • <code>in-Memory</code>: Oracle Database In-Memory
<code>-to <i>dbclass</i></code>	(Optional) Changes the database size class.
<code>-h</code>	(Optional) Displays help for using the command.

Usage Notes



Note:

When you resize the database, the redo log file size is not modified automatically. Change the size of the redo log manually to the size that you require for your applications.

Example 5-21 Modifying the Database Type

Here are examples of how to use the `oakcli modify database` command.

Change the database type assigned to the database `dbhome_1` to a DSS database:

```
oakcli modify database DB dbhome_1 -dbtype DSS
```

Example 5-22 Modifying the Database Size

Change the database size for the database named `dbhome_1` to a 6-core CPU Oracle Database Appliance DSS database template:

```
oakcli modify database dbhome_1 -to odb-06
```

5.18.2 oakcli modify vm

Use the `oakcli modify vm` command to modify an existing virtual machine.

Syntax

```
oakcli modify vm vmname [-attachvdisk|-deletenetworkvlanname] [-s
key1:value1;key2:value2;...] [-addnetwork|-deletenetworkvlanname] [-h]
```

Parameters

Parameter	Description
<code>-attachvdiskvdisk_name</code>	(Optional) Attaches the named VDisk (virtual disk) to the named virtual machine.
<code>-detachvdiskvdisk_name</code>	(Optional) Detaches the named VDisk disk from the named virtual machine.
<code>-s</code> <code>key1:value1;key2:value2;</code> <code>...</code>	(Optional) Identifies a message consisting of one or more semicolon separated key:value pairs to send to the ovmf utility. Each key and value is separated by a colon (:) and each key/value pair is separated from the next key/value pair by quotation marks.
<code>-addnetworkvlanname</code>	(Optional) Adds a VLAN network to the named virtual machine.
<code>-deletenetworkvlanname</code>	(Optional) Removes a VLAN network from the named virtual machine.
<code>-h</code>	(Optional) Displays help for using the command.

Usage Notes

- Do not use the `-attachvdisk` or the `-detachvdisk` option with the `-addnetwork`, `-deletenetwork`, or `-s` parameters.
- Include only one of the `-addnetwork`, `-deletenetwork`, or `-s` parameters when you use this command.

Example 5-23 Sending a Message to a Running Virtual Machine

Update the `root` user password for the `gc_11g` virtual machine:

```
oakcli modify vm gc_11g -s "com.oracle.linux.root-password:password"
```

5.18.3 oakcli modify vmtemplate

Use the `oakcli modify vmtemplate` command to add networks to or delete networks from an existing virtual machine template.

Syntax

```
oakcli modify vmtemplate vmtemplatename [-addnetwork|-deletenetworkvlanname] [-h]
```

Parameters

Parameter	Description
<code>-addnetworkvlanname</code>	(Optional) Adds a VLAN network to the named virtual machine template
<code>-deketenetworkvlanname</code>	(Optional) Deletes a VLAN network from the named virtual machine template
<code>-h</code>	(Optional) Displays help for using the command.

Example 5-24 Modifying the Network Defined in a Virtual Machine Template

Replace the network assigned to the `gc_11g` virtual machine template with the `net1` network:

```
oakcli modify vmtemplate gc_11g -addnetwork net1
```

5.19 oakcli orachk

Use the `oakcli orachk` command to audit configuration settings with the ORAchk utility.

Syntax

```
oakcli orachk [-a|-b|-v|-h|-p|-f|-m[-u -o][o]-c -t][[-clusternodes | -localonly][[-debug][[-dbnames | -dbnone|-dball]][upgrade]listlist
```

Parameters

Parameter	Description
<code>-a</code>	Perform a best practice check and recommended patch check.
<code>-b</code>	Perform a best practice check only without the recommended patch check.
<code>-v</code>	Display version.
<code>-h</code>	Display command usage (help).
<code>-p</code>	Perform patch check only.
<code>-f</code>	Run the command offline.
<code>-m</code>	Exclude checks for Maximum Availability scorecards.
<code>-u -o</code>	Perform check on pre-upgrade best practices (-u -o pre) or on post-upgrade best practices (-u -o post).

Parameter	Description
-o	As an argument to an option, if -o is followed by v, V, Verbose, or VERBOSE, output will display checks that pass on the display. Without the -o option, only failures will display on the screen.
-c	Determines granularity of information displayed on the screen. For use only when working with Oracle Support Services.
-clusternodes <i>list</i>	<i>list</i> is a comma-delimited list containing the names of the nodes where the command should run.
-localonly	Run the command only on the local node.
-debug	Creates a debug log.
-dbnames <i>list</i>	<i>list</i> is a comma-delimited list containing the names of the subset of databases on which the command should run.
-dbnone	Skip all database-related checks on all databases without prompting to select which database to skip.
-dball	Run all database-related checks on all databases without prompting to select which databases to check.
-upgrade	Force upgrade of the version of the ORAchK utility being run.

Usage Notes

- The command offers multiple options that are generic to the ORAchK command when run on servers other than the Oracle Database Appliance server. You can find details about these options by running the command `oakcli orachk -h`. The options are grouped into the following categories, but this document does not list the options for each category:
 - Report Options
 - Auto Restart Options
 - Daemon Options
 - Profile Run Options
- For more information about ORAchK, see My Oracle Support note 1268927.2, "ORAchK Health Checks for the Oracle Stack" at <https://support.oracle.com/CSP/main/article?cmd=show&type=NOT&id=1268927.2>

5.20 oakcli reconfigure osparams

Use the `oakcli reconfigure osparams` command to adjust the kernel parameters based on the available RAM after you upgrade memory or DIMM.

After you change or expand memory on Oracle Database Appliance, use the `oakcli reconfigure osparams` command to display the current configuration and suggested values for `memlock` and `vm.nr_hugepages`. When prompted, answer `yes` or `no` to change the value to the suggested value.

Syntax

```
oakcli reconfigure osparams [-h]
```

Parameters

Parameter	Description
-h	(Optional) Displays help for using the command.

Usage Notes

After you change or expand memory on Oracle Database Appliance, use this command to update the kernel parameters.



Note:

When adjusting the settings, ensure that you make the changes on both nodes.

Example 5-25 Viewing the Current and Suggested Kernel Parameters

In this example, the output displays the configured and suggested values for `memlock` and `vm.nr_hugepages`. When prompted, enter `no` for both parameters to view, but not implement the suggested values.

```
# oakcli reconfigure osparams
Configured value for memlock is: 11000000
Suggested value for memlock is: 11000000
Do you want to use suggested value of memlock?: yes/no
no
User entered no, not updating kernel.memlock
Configured value for vm.nr_hugepages is: 2048
Suggested value for vm.nr_hugepages parameter is: 4150
Do you want to update to suggested value?: yes/no
no
User entered no, not updating kernel.vm.nr_hugepages
```

Example 5-26 Reconfiguring the Kernel Based on Available RAM

In this example, the output displays the configured and suggested values for `memlock` and `vm.nr_hugepages`. The `memlock` value does not require changing. A new value is suggested for `vm.nr_hugepages`. When prompted, enter `yes` to update to the suggested value.



Note:

You must adjust the value on both nodes.

```
# oakcli reconfigure osparams
Configured value for memlock is: 193000000
Suggested value for memlock is: 193000000
Configured and suggested values are same
Configured value for vm.nr_hugepages is: 67815
Suggested value for vm.nr_hugepages parameter is: 67748
Do you want to update to suggested value?: yes/no
yes
```

5.21 oakcli resize dbstorage

Use the `oakcli resize dbstorage` command to resize the space used for a storage structure that was created for the purpose of migrating databases from Oracle ASM to Oracle ACFS.

You can check the current space usage using `oakcli show fs` and then add space using `oakcli resize dbstorage`.

 **Note:**

You cannot decrease the size of the space used for Oracle ACFS.

Syntax

```
oakcli resize dbstorage -data size -reco size -redo size -db db_name [-h]
```

Parameters

Parameter	Description
-data <i>size</i>	Extendable size in GB for the DATA volume.
-reco <i>size</i>	Extendable size in GB for the REDO volume.
-redo <i>size</i>	Extendable size in GB for the RECO volume.
-db <i>db_name</i>	Database for which these volumes must be resized.
-h	(Optional) Display help for using the command.

Example 5-27 Increasing the Size of the DATA Volume

Increase the size of the volume by 10 GB on the DATA volume:

```
oakcli resize dbstorage -data 10
```

5.22 oakcli restart oda_base

Use the `oakcli restart oda_base` command to stop and restart ODA_BASE on the local node.

Use this command only when you are not concerned about the current status of ODA_BASE, because it performs a forced shutdown. You must run this command from `Dom0`. Typically, if ODA_BASE needs to be restarted, then you must restart it on both nodes.

Syntax

```
oakcli restart oda_base [-h]
```

The ODA_BASE that you want to restart is on the same node as the `Dom0` from which you run this command.

Parameter

(Optional) `-h` displays help for using the command.

5.23 oakcli show commands

Use the `oakcli show` commands to display the status of Oracle Database Appliance components.

The `oakcli show` commands display status information for the node where you run the command. To see the list of components available on the current node, use the help option: `oakcli show -h`:

 **Note:**

Depending on your model and version of Oracle Database Appliance software, the `oakcli show` command options may differ from the ones shown in this section and explained in the following sections. To obtain an annotated list of components available on your system, run the command `oakcli show -h`.

- [oakcli show asr](#) (page 5-52)
Use the `oakcli show asr` command to display your Oracle Auto Service Request configuration details.
- [oakcli show cooling](#) (page 5-53)
Use the `oakcli show cooling` command to display the status of the cooling units.
- [oakcli show controller](#) (page 5-53)
Use the `oakcli show controller` command to display information about the disk controllers.
- [oakcli show core_config_key](#) (page 5-54)
Use the `oakcli show core_config_key` command to display information about how to deploy your Oracle Database Appliance cores.
- [oakcli show cpupool](#) (page 5-54)
Use the `oakcli show cpupool` command to display core allocations to virtual machine mappings.
- [oakcli show databases](#) (page 5-55)
Use the `oakcli show databases` command to display information about each existing database, including database name, database type, database home name and location, and database version.
- [oakcli show db_config_params](#) (page 5-55)
Use the `oakcli show db_config_params` command to display configuration file names and parameters.
- [oakcli show dbhomes](#) (page 5-56)
Use the `oakcli show dbhomes` command to display information about each existing Oracle database home, including home name, home location, and database version.

- [oakcli show dbstorage](#) (page 5-56)
Use the `oakcli show dbstorage` command to display database storage information for databases created on Oracle Automatic Storage Management Cluster File System (Oracle ACFS).
- [oakcli show disk](#) (page 5-57)
Use the `oakcli show disk` command to display disk information.
- [oakcli show diskgroup](#) (page 5-58)
Use the `oakcli show diskgroup` command to display Oracle Automatic Storage Management (Oracle ASM) disk group information.
- [oakcli show enclosure](#) (page 5-59)
Use the `oakcli show enclosure` command to display information about the storage enclosure subsystem on the node where the command is executed.
- [oakcli show env_hw](#) (page 5-59)
Use the `oakcli show env_hw` command to display the environment type and hardware version of the current node.
- [oakcli show expander](#) (page 5-59)
Use the `oakcli show expander` command to display information about a SAS expander.
- [oakcli show ib](#) (page 5-60)
Use the `oakcli show ib` command to display InfiniBand card and port information if InfiniBand exists in the system.
- [oakcli show fs](#) (page 5-60)
Use the `oakcli show fs` command to display all database and cloudfs file systems created on ASM Cluster File System (ACFS) in addition to the local file systems on the Oracle Database Appliance node.
- [oakcli show iraid](#) (page 5-60)
Use the `oakcli show iraid` command to display internal RAID and local disk information.
- [oakcli show ismaster](#) (page 5-60)
Use the `oakcli show ismaster` command to determine which node is the master node.
- [oakcli show memory](#) (page 5-61)
Use the `oakcli show memory` command to display information about memory modules.
- [oakcli show network](#) (page 5-61)
Use the `oakcli show network` command to display information about the network subsystem.
- [oakcli show power](#) (page 5-61)
Use the `oakcli show power` command to display information about the power supply subsystem.
- [oakcli show processor](#) (page 5-62)
Use the `oakcli show processor` command to display information about CPU processors.
- [oakcli show raidsyncstatus](#) (page 5-62)
Use the `oakcli show raidsyncstatus` command to display the status of the RAID rebuild after a failed local disk is replaced.

- [oakcli show repo](#) (page 5-63)
Use the `oakcli show repo` command to display information about virtual machine repositories.
- [oakcli show server](#) (page 5-64)
Use the `oakcli show server` command to display information about the server subsystem.
- [oakcli show storage](#) (page 5-64)
Use the `oakcli show storage` command to display information about the storage for controllers, expanders, and disks.
- [oakcli show validation storage](#) (page 5-64)
Use the `oakcli show validation storage` command to show whether validation storage is enabled or disabled.
- [oakcli show validation storage errors](#) (page 5-64)
Use the `oakcli show validation storage errors` command to show hard storage errors.
- [oakcli show validation storage failures](#) (page 5-65)
Use the `oakcli show validation storage failures` command to show soft validation errors. A typical soft disk error would be an invalid version of the disk firmware.
- [oakcli show vdisk](#) (page 5-65)
Use the `oakcli show vdisk` command to display information about virtual disks on Oracle Database Appliance Virtualized Platform.
- [oakcli show version](#) (page 5-66)
Use the `oakcli show version` command to display the applied patch versions for Oracle Database Appliance software and firmware.
- [oakcli show vlan](#) (page 5-67)
Use the `oakcli show vlan` command to display information about virtual local area networks (VLANs) configured on Oracle Database Appliance.
- [oakcli show vm](#) (page 5-68)
Use the `oakcli show vm` command to display information about virtual machines.
- [oakcli show vmconsole](#) (page 5-69)
Use the `oakcli show vmconsole` command to open a GUI virtual machine console to manage a specific virtual machine.
- [oakcli show vmtemplate](#) (page 5-70)
Use the `oakcli show vmtemplate` command to display information about virtual machine templates.

5.23.1 oakcli show asr

Use the `oakcli show asr` command to display your Oracle Auto Service Request configuration details.

Syntax

```
oakcli show asr [-h]
```

Parameters

(Optional) `-h` displays the help for using this command.

5.23.2 oakcli show cooling

Use the `oakcli show cooling` command to display the status of the cooling units.

Syntax

```
oakcli show cooling [-h]
```

Parameters

(Optional) `-h` displays the help for using this command.

Example

Display the cooling unit information for the node where the command is executed:

```
oakcli show cooling
NAME    HEALTH HEALTH_DETAILS LOCATION FAN % FAN SPEED
Fan_0   OK      -             FM0     30 % 6300 RPM
Fan_1   OK      -             FM0     19 % 3800 RPM
Fan_10  OK      -             FM2     34 % 6600 RPM
Fan_11  OK      -             FM2     23 % 4100 RPM
Fan_12  OK      -             FM3     32 % 6300 RPM
Fan_13  OK      -             FM3     22 % 3900 RPM
Fan_14  OK      -             FM3     24 % 4700 RPM
Fan_15  OK      -             FM3     14 % 2500 RPM
Fan_2   OK      -             FM0     29 % 6400 RPM
Fan_3   OK      -             FM0     18 % 3700 RPM
Fan_4   OK      -             FM1     32 % 6400 RPM
Fan_5   OK      -             FM1     20 % 3700 RPM
Fan_6   OK      -             FM1     33 % 6400 RPM
Fan_7   OK      -             FM1     22 % 3800 RPM
Fan_8   OK      -             FM2     33 % 6400 RPM
Fan_9   OK      -             FM2     22 % 3900 RPM
```

5.23.3 oakcli show controller

Use the `oakcli show controller` command to display information about the disk controllers.

Syntax

```
oakcli show controller controller_id [-h]
```

Parameters

Parameter	Description
<code>controller_id</code>	Specifies the controller for which to display information
<code>-h</code>	(Optional) Display help for using the command.

Displaying Disk Controller Details

Display details of controller 0:

```
oakcli show controller 0
```

5.23.4 oakcli show core_config_key

Use the `oakcli show core_config_key` command to display information about how to deploy your Oracle Database Appliance cores.

Syntax

```
oakcli show core_config_key
```

Examples

Here are examples of how to use the `oakcli show core_config_key` command.

Determining Whether the Oracle Database Appliance Core Configuration Key Has Been Applied

Show the core count status on a new Oracle Database Appliance that has not been configured:

```
oakcli show core_config_key
Optional core_config_key is not applied on this machine yet!
```

Displaying the Oracle Database Appliance Core Count Status on a Configured Oracle Database Appliance

Show the core count status on a previously configured Oracle Database Appliance:

```
oakcli show core_config_key
Host's serialnumber = 1132FMW003
Configured Cores = 20
```

5.23.5 oakcli show cpupool

Use the `oakcli show cpupool` command to display core allocations to virtual machine mappings.

Syntax

```
oakcli show cpupool -node nodenum
```

nodenum is the number of the Oracle Database Appliance node that you want to examine, either 0 or 1.

Displaying Core Mapping for Node 0

Display the core mapping information for Node 0:

```
oakcli show cpupool -node 0
      Pool          Cpu List          VM List
default-unpinned-pool [14, 15, 16, 17, 18, 19, 20, 21, 22, 23] ['test1_odarepol', 'sample5_odarepol', 'vm_very_long_name_sample1_odarepol', 'win_vml']
      twocpu        [12, 13]          ['vml_odarepol']
odaBaseCpuPool       [0, 1, 2, 3, 10, 11]
```

5.23.6 oakcli show databases

Use the `oakcli show databases` command to display information about each existing database, including database name, database type, database home name and location, and database version.

Syntax

```
oakcli show databases [-h]
```

Parameters

(Optional) `-h` displays help for using the command.

Example

```
#oakcli show databases
```

Name	Type	Storage	HomeName	HomeLocation	Version
db1	RAC	ACFS	OraDb12102_home1	/u01/app/oracle/product/12.1.0.2/dbhome_1	12.1.0.2.5(21359755,21359758)
db2	SINGLE	ACFS	OraDb12102_home2	/u01/app/oracle/product/12.1.0.2/dbhome_2	12.1.0.2.5(21359755,21359758)
db3	RACOneNode	ACFS	OraDb12102_home3	/u01/app/oracle/product/12.1.0.2/dbhome_3	12.1.0.2.5(21359755,21359758)
db4	RAC	ACFS	OraDb12102_home4	/u01/app/oracle/product/12.1.0.2/dbhome_4	12.1.0.2.5(21359755,21359758)

5.23.7 oakcli show db_config_params

Use the `oakcli show db_config_params` command to display configuration file names and parameters.

The command searches for files with the extension `.dbconf` located in the `/opt/oracle/oak/install/dbconf` directory.

Syntax

```
oakcli show db_config_params [-conf filename] [-detail] [-h]
```

Parameters

Parameter	Description
<code>-conf filename</code>	(Optional) Name of configuration file to be displayed. If not included, then the command displays all configuration files.
<code>-detail</code>	(Optional) Display the parameter values stored in the configuration file or files.
<code>-h</code>	(Optional) Display help for using the command.

Displaying the Default Database Configuration Parameters

Display the default database configuration parameter values stored in the configuration file or files:

```
oakcli show db_config_params -detail
Available DB configuration files are:
    Default
    DATABASE_BLOCK_SIZE      =>      8192
```

```

DATABASE_LANGUAGE      =>  AMERICAN
DATABASE_CHARACTERSET  =>  AL32UTF8
DATABASE_TERRITORY    =>  AMERICA
COMPONENT_LANGUAGES   =>  en

```

5.23.8 oakcli show dbhomes

Use the `oakcli show dbhomes` command to display information about each existing Oracle database home, including home name, home location, and database version.

Syntax

```
oakcli show dbhomes [-detail] [-h]
```

Parameters

Parameter	Description
-detail	(Optional) Include a list of databases associated with each home.
-h	(Optional) Display help for using the command.

Example

```
oakcli show dbhomes -detail
```

Oracle HomeName	Oracle Home Version	Oracle HomeLocation	Database Name	Database Type
OraDb11203_home1	11.2.0.3.15(20760997,17592127)	/u01/app/oracle/product/11.2.0.3/dbhome_1	no DB	available
OraDb11204_home1	11.2.0.4.8(21352635,21352649)	/u01/app/oracle/product/11.2.0.4/dbhome_1	no DB	available
OraDb12102_home1	12.1.0.2.5(21359755,21359758)	/u01/app/oracle/product/12.1.0.2/dbhome_1	one43	RACOneNode
OraDb12102_home1	12.1.0.2.5(21359755,21359758)	/u01/app/oracle/product/12.1.0.2/dbhome_1	ee120	SINGLE
OraDb12102_home1	12.1.0.2.5(21359755,21359758)	/u01/app/oracle/product/12.1.0.2/dbhome_1	one311	RACOneNode
OraDb12102_home1	12.1.0.2.5(21359755,21359758)	/u01/app/oracle/product/12.1.0.2/dbhome_1	ee311	SINGLE
OraDb12102_home1	12.1.0.2.5(21359755,21359758)	/u01/app/oracle/product/12.1.0.2/dbhome_1	rac311	RAC
OraDb12102_home1	12.1.0.2.5(21359755,21359758)	/u01/app/oracle/product/12.1.0.2/dbhome_1	ee43	SINGLE
OraDb12102_home1	12.1.0.2.5(21359755,21359758)	/u01/app/oracle/product/12.1.0.2/dbhome_1	one120	RACOneNode
OraDb12102_home1	12.1.0.2.5(21359755,21359758)	/u01/app/oracle/product/12.1.0.2/dbhome_1	odacn	RAC
OraDb12102_home1	12.1.0.2.5(21359755,21359758)	/u01/app/oracle/product/12.1.0.2/dbhome_1	rac43	RAC
OraDb12102_home1	12.1.0.2.5(21359755,21359758)	/u01/app/oracle/product/12.1.0.2/dbhome_1	rac120	RAC

5.23.9 oakcli show dbstorage

Use the `oakcli show dbstorage` command to display database storage information for databases created on Oracle Automatic Storage Management Cluster File System (Oracle ACFS).

All non-cdb databases are listed together, because they share a common set of volumes. Each CDB database is listed separately.

Syntax

```
oakcli show dbstorage [-db ][-h]db_name
```

Parameters

Parameter	Description
-db <i>dbname</i>	(Optional) Display the name of the database for the storage information.
-h	(Optional) Display help for using the command.

Oracle Database Appliance X5-2 with a Storage Expansion Shelf and Non-CDB Databases

Here is an example of the `oakcli show dbstorage` command output for an Oracle Database Appliance plus the storage expansion shelf. The output includes only non-CDB databases. Half of the available disk group storage is allocated to Oracle ACFS, except for the FLASH disk group. In the FLASH disk group, all storage is allocated to Oracle ACFS.

```
# oakcli show dbstorage

All the DBs with DB TYPE as non-CDB share the same volumes

DB_NAMES      DB_TYPE  Filesystem                Size  Used  Available  AutoExtend Size DiskGroup
-----
db1, db2, db3, db4 non-CDB  /u01/app/oracle/oradata/datastore  62G  27.26G  34.74G      6G      REDO
                /u02/app/oracle/oradata/datastore 3730G  7.86G  3722.14G   373G     DATA
                /u02/app/oracle/oradata/flashdata  558G  205.25G  352.75G    55G     FLASH
                /u01/app/oracle/fast_recovery_area/datastore 4958G  21.05G  4936.95G   495G     RECO
```

Oracle Database Appliance X3-2 or X4-2 with a Storage Expansion Shelf

Here is an example of the `oakcli show dbstorage` command output for an Oracle Database Appliance plus the storage expansion shelf. The output includes both CDB and non-CDB databases. The **Available** heading shows the available AFCS storage, which can be auto-extended. Half of the available disk group storage is allocated to Oracle ACFS, except for the FLASH disk group. In the FLASH disk group, all storage is allocated to Oracle ACFS.

```
# oakcli show dbstorage

All the DBs with DB TYPE as non-CDB share the same volumes

DB_NAMES      DB_TYPE  Filesystem                Size  Used  Available  AutoExtend Size DiskGroup
-----
odacn         CDB      /u01/app/oracle/oradata/rdoodacn    5G   3.15G  1.85G      1G      REDO
                /u02/app/oracle/oradata/datodacn   100G  3.86G  96.14G    10G     DATA
                /u01/app/oracle/fast_recovery_area/rcoodacn 132G  0.92G  131.08G   13G     RECO

rac120, rac401, ra non-CDB  /u01/app/oracle/oradata/datastore  60G  11.30G  48.70G     5G      REDO
c408
                /u02/app/oracle/oradata/datastore 1027G  5.77G  1021.23G  102G     DATA
                /u01/app/oracle/fast_recovery_area/datastore 1336G  7.27G  1328.73G  133G     RECO

cdbracon     CDB      /u01/app/oracle/oradata/rdoodbracon  6G   4.15G  1.85G      1G      REDO
                /u02/app/oracle/oradata/datcdbracon 100G  4.05G  95.95G    10G     DATA
                /u01/app/oracle/fast_recovery_area/rcodbracon 132G  0.79G  131.21G   13G     RECO
```

5.23.10 oakcli show disk

Use the `oakcli show disk` command to display disk information.

Syntax

```
oakcli show disk [-shared | -local | -shared_disk_name |-asm [-all]][-h]
```

Parameters

Parameter	Description
-local	(Optional) Display information for all of the local disks.
-shared	(Optional) Display information for all of the shared disks.
-shared_disk_name	(Optional) Display information for only the specified shared disk.
-asm	(Optional) Displays information for an assembly.
-all	(Optional) Display complete details of the selected disk or disks.
-h	(Optional) Display help for using the command.

Usage Notes

- Running the command with no parameters is identical to running the `oakcli show disk -shared` command.
- The `-all` parameter produces valid output only when used with the `shared_disk_name` parameter. All other parameters are optional and cannot be combined with other parameters.

Example 5-28 Displaying Information About the Local Disks

```
oakcli show disk -local
```

Example 5-29 Displaying Information About the Shared Disks

```
oakcli show disk -shared
```

Example 5-30 Displaying Information About a Specific Shared Disk

Display information about the shared disk named `pd_01`:

```
oakcli show disk -shared pd_01
```

5.23.11 oakcli show diskgroup

Use the `oakcli show diskgroup` command to display Oracle Automatic Storage Management (Oracle ASM) disk group information.

Syntax

```
oakcli show diskgroup [disk_group_name][-h]
```

Parameters

Parameter	Description
<i>disk_group_name</i>	(Optional) The name of an Oracle ASM disk group for which complete details should be displayed. If you do not specify this parameter, then information for all of the Oracle ASM disk groups is displayed.
-h	(Optional) Display help for using the command.

5.23.12 oakcli show enclosure

Use the `oakcli show enclosure` command to display information about the storage enclosure subsystem on the node where the command is executed.

Syntax

```
oakcli show enclosure [-h]
```

Parameter

`-h` displays help for using the command.

5.23.13 oakcli show env_hw

Use the `oakcli show env_hw` command to display the environment type and hardware version of the current node.

Syntax

```
oakcli show env_hw [-h]
```

Parameter

(Optional) `-h` displays help for using the command.

Example

Show the environment type and hardware model when logged in to ODA_BASE on Oracle Database Appliance X3-2 Virtualized Platform:

```
oakcli show env_hw
VM-ODA_BASE ODA X3-2
```

5.23.14 oakcli show expander

Use the `oakcli show expander` command to display information about a SAS expander.

Syntax

```
oakcli show expander [expander_id] [-h]
```

Parameter

Parameter	Description
<i>expander_id</i>	(Optional) Identifies the specific SAS expander
<code>-h</code>	(Optional) Display help for using the command.

5.23.15 oakcli show ib

Use the `oakcli show ib` command to display InfiniBand card and port information if InfiniBand exists in the system.

Syntax

```
oakcli show ib [-h]
```

Parameter

(Optional) `-h` displays help for using the command.

5.23.16 oakcli show fs

Use the `oakcli show fs` command to display all database and cloudfs file systems created on ASM Cluster File System (ACFS) in addition to the local file systems on the Oracle Database Appliance node.

Syntax

```
oakcli show fs [-h]
```

Parameter

(Optional) `-h` displays help for using the command.

5.23.17 oakcli show iraid

Use the `oakcli show iraid` command to display internal RAID and local disk information.

This command is only available on X5-2 systems and later.

Syntax

```
oakcli show iraid [-h]
```

Parameter

(Optional) `-h` displays help for using the command.

5.23.18 oakcli show ismaster

Use the `oakcli show ismaster` command to determine which node is the master node.

File Path

```
$ORACLE_HOME/opt/oracle/oak/bin/oakcli
```

Syntax

```
oakcli show ismaster [-h]
```

Parameters

Parameter	Description
-h	(Optional) Display help for using the command.

Example 5-31 Determining Which Node is the Master Node

```
# oakcli show ismaster
```

5.23.19 oakcli show memory

Use the `oakcli show memory` command to display information about memory modules.

Syntax

```
oakcli show memory [-h]
```

Parameter

(Optional) `-h` displays help for using the command.

5.23.20 oakcli show network

Use the `oakcli show network` command to display information about the network subsystem.

Syntax

```
oakcli show network
```

Parameter

(Optional) `-h` displays help for using the command.

5.23.21 oakcli show power

Use the `oakcli show power` command to display information about the power supply subsystem.

Syntax

```
oakcli show power [-h]
```

Parameter

(Optional) `-h` displays help for using the command.

Example 5-32 Displaying Power Supply Information

Display the power supply information of the node where the command is executed:

```
# oakcli show power
```

```
NAME                HEALTH HEALTH_DETAILS PART_NO. SERIAL_NO.          LOCATION
```

```

INPUT_POWER OUTPUT_POWER INLET_TEMP      EXHAUST_TEMP
Power_Supply_0 OK      -              7047410  476856F+1242CE0020 PS0
Present      113 watts  33.250 degree C 36.688 degree C
Power_Supply_1 OK      -              7047410  476856F+1242CE004J PS1
Present      89 watts  37.000 degree C 39.438 degree C

```

5.23.22 oakcli show processor

Use the `oakcli show processor` command to display information about CPU processors.

Syntax

```
oakcli show processor [-h]
```

Parameter

(Optional) `-h` displays help for using the command.

Displaying CPU Processor Information

Display the CPU processor information of the node where the command is executed:

```

oakcli show processor
      NAME HEALTH HEALTH_DETAILS PART_NO. LOCATION
MODEL                                MAX_CLK_SPEED TOTAL_CORES ENABLED_CORES

      CPU_0 OK      -              060D      P0 (CPU 0)
Intel(R) Xeon(R) CPU E5-2690 2.900 GHZ      8          8
      CPU_1 OK      -              060D      P1 (CPU 1)
Intel(R) Xeon(R) CPU E5-2690 2.900 GHZ      8          8

```

5.23.23 oakcli show raidsyncstatus

Use the `oakcli show raidsyncstatus` command to display the status of the RAID rebuild after a failed local disk is replaced.



Note:

The `show raidsyncstatus` command is only supported on a bare metal platform; it is not supported on the virtualized platform. For general RAID information, use the `oakcli show iraid` command.

Syntax

```
oakcli show raidsyncstatus [-h]
```

Parameter

(Optional) `-h` displays help for using the command.

5.23.24 oakcli show repo

Use the `oakcli show repo` command to display information about virtual machine repositories.

Syntax

```
oakcli show repo [reponame -node 0|1] [-h]
```

Parameters

Parameter	Description
<code>reponame</code>	[Optional] Identifies a specific repository name
<code>-node</code>	[Optional] Identifies the node number 0 or 1
<code>-h</code>	[Optional] Display help for using the command.

To see all repositories, omit the repository name and node number. To see a specific shared repository, include the repository name and node.

Examples

Here are examples of how to use the `oakcli show repo` command.

Example 5-33 Displaying the Available Virtual Machine Repositories

Display the virtual machine repositories on Oracle Database Appliance Virtualized Platform nodes:

```
oakcli show repo
NAME      REPOTYPE  NODENUM
odarepo1  local     0
odarepo2  local     1
repo1     shared    0
repo1     shared    1
```

Example 5-34 Displaying Details About a Specific Shared Repository

Display information about the repository named `repo1` on Node 1:

```
oakcli show repo repo1 -node 1

Resource: repo1_1
AutoStart      : restore
DG             : DATA
Device         : /dev/asm/repo1-286
ExpectedState  : Online
MountPoint     : /u01/app/repo1
Name           : repo1_0
Node           : all
RepoType       : shared
Size           : 102400
State          : Online
```

5.23.25 oakcli show server

Use the `oakcli show server` command to display information about the server subsystem.

Syntax

```
oakcli show server [-h]
```

Parameter

(Optional) `-h` displays help for using the command.

5.23.26 oakcli show storage

Use the `oakcli show storage` command to display information about the storage for controllers, expanders, and disks.

Syntax

```
oakcli show storage -errors [-h]
```

Parameters

Parameter	Description
<code>-errors</code>	Display detailed information about reported errors.
<code>-h</code>	(Optional) Display help for using the command.

5.23.27 oakcli show validation storage

Use the `oakcli show validation storage` command to show whether validation storage is enabled or disabled.

Syntax

```
oakcli show validation storage [-h]
```

Parameter

(Optional) `-h` displays help for using the command.

Example 5-35 Determining if Storage Validation is Enabled

```
# oakcli show validation storage  
Enabled
```

5.23.28 oakcli show validation storage errors

Use the `oakcli show validation storage errors` command to show hard storage errors.

Hard errors include having the wrong type of disk inserted into a particular slot, an invalid disk model, or an incorrect disk size.

Syntax

```
oakcli show validation storage errors [-h]
```

Parameter

(Optional) `-h` displays help for using the command.

5.23.29 oakcli show validation storage failures

Use the `oakcli show validation storage failures` command to show soft validation errors. A typical soft disk error would be an invalid version of the disk firmware.

Syntax

```
oakcli show validation storage failures [-h]
```

Parameter

(Optional) `-h` displays help for using the command.

5.23.30 oakcli show vdisk

Use the `oakcli show vdisk` command to display information about virtual disks on Oracle Database Appliance Virtualized Platform.

Syntax

```
oakcli show vdisk [vdisk_name -repo repository_name] [-h]
```

Parameters

Parameter	Description
<i>vdisk_name</i>	(Optional) Display information for just one virtual disk.
-repo <i>repository_name</i>	Required parameter if a virtual disk is specified in the command
-h	(Optional) Display help for using the command.

Examples

Here are examples of how to use the `oakcli show vdisk` command.

Example 5-36 Displaying Information for All Virtual Disks

Display information about all virtual disks on Oracle Database Appliance Virtualized Platform:

```
# oakcli show vdisk
```

```

NAME                SIZE  TYPE  REPOSITORY
myvdisk             10G   local  vdiskrepo
newv                 1G    local  vdiskrepo
```

Example 5-37 Displaying Information for a Single Virtual Disk

Display information for the virtual disk named `myvdisk1`:

```
# oakcli show vdisk myvdisk1
Resource: myvdisk_vdiskrepo
  Name       : myvdisk_vdiskrepo
  RepoName   : vdiskrepo
  Size       : 10G
  Type       : local
  VmAttached : 0
```

5.23.31 oakcli show version

Use the `oakcli show version` command to display the applied patch versions for Oracle Database Appliance software and firmware.

Syntax

```
oakcli show version [-detail] [-h]
```

Parameter	Description
-detail	(Optional) Display detailed version information.
-h	(Optional) Display help for using the command.

Usage Notes

When you apply the patch and then run the command `oakcli show version -detail`, the output shows the installed version and that the supported versions are `Up-to-date` for each component. If you unpack the patch bundle (`oakcli unpack -pack`) and then run the command `oakcli show version -detail` before applying the patch, the output shows `No-update` in the Supported Version column.



Note:

After unpacking the patch bundle, but before applying the patch, use the `oakcli update -patch version --verify` command to verify the contents of the patch instead of issuing `oakcli show version -detail`.

Displaying the Oracle Database Appliance Version

This is an example of how to determine if all of the components are successfully updated after applying the 12.1.2.10.0 patch. You can also view the applied patch version information for the software and firmware on Oracle Database Appliance. All components are successfully updated when `Up-to-date` appears in the Supported Version column.

```
# oakcli show version -detail

Mon Feb 13 03:31:48 PST 2017
Reading the metadata. It takes a while...
System Version  Component Name  Installed Version  Supported Version
-----
12.1.2.10.0
                Controller_INT  4.230.40-3739    Up-to-date
                Controller_EXT  09.00.00.00     Up-to-date
                Expander       0291             Up-to-date
                SSD_SHARED {
```

```

[ c2d20,c2d21,c2d22,      A29A                Up-to-date
c2d23 ]

[ c2d0,c2d1,c2d2,c2d     A29A                Up-to-date
3,c2d4,c2d5,c2d6,c2d
7,c2d8,c2d9,c2d10,c2
d11,c2d12,c2d13,c2d1
4,c2d15,c2d16,c2d17,
c2d18,c2d19 ]

}

SSD_LOCAL                0R3Q                Up-to-date
ILOM                     3.2.8.24 r114611    Up-to-date
BIOS                    38070000            Up-to-date
IPMI                    1.8.12.4            Up-to-date
HMP                     2.3.5.2.8           Up-to-date
OAK                     12.1.2.10.0         Up-to-date
OL                      6.8                 Up-to-date
GI_HOME                 12.1.0.2.170117(2473  Up-to-date
                        2082,24828633)
DB_HOME                 12.1.0.2.170117(2473  Up-to-date
                        2082,24828633)

```

Related Topics

- [oakcli update](#) (page 5-75)
Use the `oakcli update` command to apply Oracle Database Appliance patches.

5.23.32 oakcli show vlan

Use the `oakcli show vlan` command to display information about virtual local area networks (VLANs) configured on Oracle Database Appliance.

Syntax

```
oakcli show vlan [-h]
```

Parameter

(Optional) `-h` displays help for using the command.

Example 5-38 Displaying Details of Available Virtual Area Networks (VLANs)

Display the names, tag ID numbers, networks, and node assignments for the available virtual local area networks:

```
oakcli show vlan
```

NAME	ID	INTERFACE	NODENUM
net1	1	bond1	0
net1	1	bond1	1

```

net2                1    bond2    0
net2                1    bond2    1
net3                1    bond3    0
net3                1    bond3    1
net4                1    xbond0   0
net4                1    xbond0   1
priv1               1    bond0    0
priv1               1    bond0    1

```

5.23.33 oakcli show vm

Use the `oakcli show vm` command to display information about virtual machines.

Syntax

```
oakcli show vm [vm_name | -h]
```

Parameters

Parameter	Description
<code>vm_name</code>	(Optional) The name of the virtual machine for which details should be displayed. If you do not specify this parameter, then information for all the virtual machines is displayed.
<code>-h</code>	(Optional) Display help for using the command.

Usage Notes

When a virtual machine is configured in driver domain mode, the output of the `oakcli show vm vmname` command displays TRUE for the DriverDomain attribute.

Examples

Here are examples of how to use the `oakcli show vm` command.

Example 5-39 Displaying Details for All Virtual Machines

Display the virtual machine names, memory and vCPU allocations, status, virtual disks, and repository name for all virtual machines:

```
# oakcli show vm
```

NAME	MEMORY	VCPU	STATE	REPOSITORY
sample5_odarepo1	2048	2	OFFLINE	odarepo1
sample6_odarepo1	2048	2	OFFLINE	odarepo2
test1_odarepo1	2048	2	OFFLINE	odarepo1
test2_odarepo2	2048	2	OFFLINE	odarepo2
vm1_odarepo1	4096	4	ONLINE	odarepo1
vm2_odarepo2	2048	2	OFFLINE	odarepo2
win_vm1	1500	1	ONLINE	odarepo1

Example 5-40 Displaying Information for a Single Virtual Machine

Display information about the `vm1_odarepo1` virtual machine:

```
oakcli show vm vm1_odarepo1
Resource: vm1_odarepo1
      AutoStart      :      restore
```

```

CPUPriority      :      100
Disks           :      |file:/OVS/Repositories/odarepo1/Vi
                  rtualMachines/vml_odarepo1/System.i
                  mg,xvda,w||file:/OVS/Repositories/o
                  darepo1/VirtualMachines/vml_odarepo
                  1/u01.img,xvdb,w|
Domain          :      XEN_PVM
ExpectedState   :      online
FailOver        :      false
IsSharedRepo    :      false
Keyboard        :      en-us
MaxMemory       :      3000
MaxVcpu         :      4
Memory          :      4096
Mouse           :      OS_DEFAULT
Name            :      vml_odarepo1
Networks        :      |mac=00:21:F6:00:00:E4|
NodeNum         :      0
NodeNumStart    :
OS              :      OL_5
PrivateIP       :      None
ProcessorCap    :      100
RepoName        :      odarepo1
State           :      Online
TemplateName    :      otml_sample1_odarepo1
Vcpu            :      4
cpupool         :      twocpu
vncport         :      5901

```

5.23.34 oakcli show vmconsole

Use the `oakcli show vmconsole` command to open a GUI virtual machine console to manage a specific virtual machine.

Syntax

```
oakcli show vmconsole vm_name [-h]
```

Parameters

Parameter	Description
<i>vm_name</i>	Name of the virtual machine for which you want to open a console.
-h	(Optional) Display help for using the command.

Example 5-41 Opening a Virtual Machine Console

Open a console for the virtual machine named `vml_odarepo1`:

```
oakcli show vmconsole vml_odarepo1
```

5.23.35 oakcli show vmtemplate

Use the `oakcli show vmtemplate` command to display information about virtual machine templates.

Syntax

```
oakcli show vmtemplate [vmtemplate_name | -h]
```

Parameters

Parameter	Description
<i>vmtemplate_name</i>	(Optional) The name of the virtual template for which details should be displayed. If you do not specify this parameter, then information for all of the virtual templates is displayed.
-h	(Optional) Display help for using the command.

Example 5-42 Display Information About a Virtual Template

Display information about the `sample1_odarepo1` virtual template:

```
oakcli show vmtemplate sample_odarepo1
Resource: sample1_odarepo1
  CPUPriority      :      100
  Disks            :      |file:/OVS/Repositories/odarepo1/Te
                    |mplates/otml_sample1_odarepo1/Syste
                    |m.img,xvda,w||file:/OVS/Repositorie
                    |s/odarepo1/Templates/otml_sample1_o
                    |darepo1/u01.img,xvdb,w|
  Domain          :      XEN_PVM
  Keyboard        :      en-us
  MaxMemory       :      2048
  MaxVcpu         :      2
  Memory          :      2048
  Mouse          :      OS_DEFAULT
  Name            :      sample1_odarepo1
  Networks        :      |bridge=priv1||bridge=net1||bridge=
                    |net2|
  NodeNum        :      0
  OS              :      OL_5
  ProcessorCap    :      100
  RepoName       :      odarepo1
  Vcpu           :      2
```

5.24 oakcli start commands

Use the `oakcli start` commands to start a virtual machine, to start a shared repository on a node, or to start ODA_BASE on the local node.

- [oakcli start oda_base](#) (page 5-71)
Use the `oakcli start oda_base` command to start ODA_BASE on the local node.
- [oakcli start repo](#) (page 5-71)
Use the `oakcli start repo` command to start a shared repository on a node.

- [oakcli start vm](#) (page 5-71)
Use the `oakcli start vm` command to start a virtual machine on a node.

5.24.1 oakcli start oda_base

Use the `oakcli start oda_base` command to start ODA_BASE on the local node.

Syntax

```
oakcli start oda_base [-h]
```

Parameter

(Optional) `-h` displays help for using the command.

Example 5-43 Starting ODA_BASE on the Local Node

Connect to Dom0 on the desired node and enter the following command to start ODA_BASE on that node:

```
oakcli start oda_base
```

5.24.2 oakcli start repo

Use the `oakcli start repo` command to start a shared repository on a node.

Syntax

```
oakcli start repo repo_name [-node node_number] [-h]
```

Parameters

Parameter	Description
<i>repo_name</i>	<i>repo_name</i> is the name of the shared repository to be started.
<code>-node <i>node_number</i></code>	Specifies the node on which to start the shared repository. <i>node_number</i> is the number of the node where it is to be started, either 0 or 1. If <code>-node</code> is not specified, the shared repository is started on both nodes.
<code>-h</code>	(Optional) Displays help for using the command.

Example 5-44 Starting a Shared Repository on Node 0

Start the shared repository named `repo1` on Node 0:

```
oakcli start repo repo1 -node 0
```

5.24.3 oakcli start vm

Use the `oakcli start vm` command to start a virtual machine on a node.

Syntax

```
oakcli start vm vm_name [-node node_number] [-d] [-h]
```

Parameters

Parameter	Description
<i>vm_name</i>	<i>vm_name</i> is the name of the virtual machine to be started.
<code>-node node_number</code>	Specifies the node on which to start the virtual machine. <i>node_number</i> is the number of the node where it is to be started, either 0 or 1. If <code>-node</code> is not specified, a virtual machine is started on both nodes.
<code>-d</code>	Provides details about the virtual machine starting procedure
<code>-h</code>	(Optional) Display help for using the command.

Example 5-45 Starting a Virtual Machine on Node 0

Start the virtual machine named `vm1_odarepo1` on Node 0.

```
oakcli start vm vm_odarepo1 -node 0
```

5.25 oakcli stop command

Use the `oakcli stop` command to stop a virtual machine, to stop a shared repository on a node, or to stop ODA_BASE on the local node.

Syntax

```
oakcli stop [vm vm_name [-force] | repo repo_name [-node node_number] | oda_base ] [-h]
```

Parameters

Parameter	Description
vm <i>vm_name</i>	<i>vm_name</i> is the name of the virtual machine to be stopped.
<code>-force</code>	(Optional) forces the virtual machine to stop.
repo <i>repo_name</i>	<i>repo_name</i> is the name of the shared repository to be stopped.
<code>-node node_number</code>	<i>node_number</i> is the number of the node where the shared repository is to be stopped, either 0 or 1. The <code>-node</code> parameter is only valid when stopping a virtual machine on a shared repository. If <code>-node</code> is not specified, the shared repository is stopped on both nodes.
oda_base	Stops ODA_BASE on the local node
<code>-h</code>	(Optional) Displays help for using the command.

Examples

Here are examples of how to use the `oakcli stop` command.

Example 5-46 Forcing a Virtual Machine to Stop

Force the virtual machine named `vm1_odarepo1` to stop:

```
oakcli stop vm vm_odarepo1 -force
```

Example 5-47 Stopping a Shared Repository

Stop the shared repository named `repo1` on Node 0:

```
oakcli stop repo repo1 -node 0
```

Example 5-48 Stopping the Local ODA_Base

Connect to Dom0 on the desired node and enter the following command to stop ODA_BASE on that node:

```
oakcli stop oda_base
```

5.26 oakcli stordiag

Use the `oakcli stordiag` command to run diagnostic tests on a disk in the storage shelf or storage expansion shelf.

The tool produces a list of 14 disk checks for each node.

Syntax

```
oakcli stordiag resource_type [n] [-h]
```

Parameters

Parameter	Description
<i>resource_type</i>	Prefix that depends on the configuration. See "Usage Notes."
<i>n</i>	(Optional) Disk number (starting with 0 and increasing to one less than the number of disks)
<code>-h</code>	(Optional) Display help for using the command.

Usage Notes

Select the value for *resource_type* based from one of the following options:

- On Oracle Database Appliance Version 1, use `d`.
- On Oracle Database Appliance with a single storage shelf, use `pd_`.
- On Oracle Database Appliance with an expansion storage shelf, use `e0_pd_` for a disk in the storage shelf and use `e1_pd_` for a disk in the expansion storage shelf.

For Oracle Database Appliance systems that have internal storage, use the format `d_[.]` to identify the disk to be diagnosed. For Oracle Database Appliance systems that have connected a storage shelf (and optional storage expansion shelf), use the format `e[0..1] pd_[0..23]` to identify the disk to be diagnosed.

Example 5-49 Running Diagnostic Tests on a Disk in the Expansion Storage Shelf

Runs the diagnostic tests on disk 3 in the expansion storage shelf:

```
# oakcli stordiag e1_pd_3
Node Name : hr0
Test : Diagnostic Test Description

  1 : OAK Check
      NAME          PATH          TYPE          STATE          STATE_DETAILS
```



```

pd_03      /dev/sdw      HDD      ONLINE      Good

2 : ASM Check
. . .
<output truncated>

```

5.27 oakcli test asr

Use the `oakcli test asr` command to send a test trap to determine if Oracle Auto Service Request (Oracle ASR) is configured and working correctly.

The command returns a success message if Oracle ASR is functioning properly.

Syntax

```
oakcli test asr [-h]
```

Parameter

(Optional) `-h` displays help for using the command.

Usage Notes

Run the command on both nodes. The Oracle ASR logs are always on the node where the ASR Manager is installed, which is the master node.

5.28 oakcli unpack

Use the `oakcli unpack` command to unpack packages into the Oracle Appliance Manager repository.

Syntax

```
oakcli unpack -package absolute_package_name
```

Parameters

Parameters	Description
<i>absolute_package_name</i>	Identifies the package to be unpacked using the package's full absolute path and file name
<code>-h</code>	(Optional) Display help for using the command.

Example 5-50 Unpacking Packages into the Oracle Appliance Manager Repository

Unpack the `p13982331_23000_Linux-86-62.zip` package, which was previously copied to `/tmp` on the current node, into the node's Oracle Appliance Manager command-line interface repository:

```
oakcli unpack -package /tmp/p13982331_23000_Linux-86-62.zip
```

5.29 oakcli update

Use the `oakcli update` command to apply Oracle Database Appliance patches.

You can apply patches using the patch bundle and use the `--local` patching option to patch components one node at a time without impacting the other node. This reduces the downtime when applying the patch.

Note:

If you want to update only the Oracle Database software, use the `oakcli upgrade` command.

Syntax

```
oakcli update -patch version [--server | --storage | --database] [--local] [--noreboot] | [--clean] | [--verify][-h]
```

Parameters

Parameter	Description
<code>- patch version</code>	Patch version that you want to install. For example: 12.2.1.3.0.
<code>--server</code>	Contains the patches previously obtained in earlier releases from the Infrastructure (infra) and Grid Infrastructure (gi) patch updates.
<code>--storage</code>	Contains only patches for shared storage components.
<code>--database</code>	(Optional) Patches Oracle database homes.
<code>--local</code>	Patches the component only on the local node on bare metal deployments. By default, this is set to false.
<code>--noreboot</code>	(Optional) Node is not rebooted after patching.
<code>--clean</code>	(Optional) Cleans up all temporary files on the local node.
<code>--verify</code>	(Optional) Lists the patchable components on the node.
<code>-h</code>	(Optional) Display help for using the command.

Usage Notes

After unpacking the patch bundle, but before applying the patch, verify the contents of the patch for the release.

Note:

When patching a virtualized platform, the `--local` option is not supported.

Example 5-51 Verify the Contents of a Patch Bundle

Display the installed version and the version available in the 12.2.1.3.0 release patch bundle for each of the components on the node. When the latest supported version is installed, `Up-to-date` appears in the Proposed column.

```
# oakcli update -patch 12.2.1.3.0 --verify

INFO: 2017-02-13 14:20:37: Reading the metadata file now...
```

Patch Version	Component Name	Installed Version	Proposed
	Controller_INT	4.230.40-3739	Up-to-date
	Controller_EXT	09.00.00.00	10.00.00.00
	Expander	0291	Up-to-date
	SSD_SHARED {		
	[c2d20,c2d21,c2d22,c2d23]	A29A	Up-to-date
	[c2d0,c2d1,c2d2,c2d3,c2d4,c2d5,c2d6,c2d7,c2d8,c2d9,c2d10,c2d11,c2d12,c2d13,c2d14,c2d15,c2d16,c2d17,c2d18,c2d19]	A29A	Up-to-date
	}		
	SSD_LOCAL	0R3Q	Up-to-date
	ILOM	3.2.7.26.a r112632	3.2.8.24 r114611
	BIOS	38050100	38070000
	IPMI	1.8.12.4	Up-to-date
	HMP	2.3.5.2.5	2.3.5.2.8
	OAK	12.2.1.2	12.2.1.3.0
	OL	6.8	Up-to-date
	GI_HOME	12.1.0.2.161018(24006101,23854735)	12.1.0.2.170117(24732082,24828633)
	DB_HOME	12.1.0.2.160719(23054246,23054327)	12.1.0.2.170117(24732082,24828633)
	ASR	5.5.1	Up-to-date

oakcli update -patch Command Examples

Update the appliance with the 12.2.1.3.0 patch:

```
oakcli update -patch 12.2.1.3.0
```

Patch the server on the current node with the 12.2.1.3.0 patch:

```
oakcli update -patch 12.2.1.3.0 --server --local
```

Patch the grid home only on the local node:

```
oakcli update -patch 12.2.1.3.0 --storage --local
```

Patch the Oracle Database homes on both nodes:

```
oakcli update -patch 12.2.1.3.0 --database
```

5.30 oakcli upgrade

Use the `oakcli upgrade` command to upgrade the Oracle Database software on Oracle Database Appliance.

For patching Oracle Database Appliance itself, use the `oakcli update` command.

Syntax

```
oakcli upgrade database [-db db_names | -from source_home] -to destination_home
```

Parameters

Parameter	Description
-db <i>db_names</i>	Specifies the name or names (in a comma-delimited list) of the database or databases you want to upgrade
-from <i>source_home</i>	Specifies the current Oracle Database home of the databases you are upgrading
-to <i>destination_home</i>	Specifies the Oracle Database home containing the version to which you want to upgrade the databases
-h	(Optional) Display help for using the command.

Usage Notes

- You must include either a `-db` parameter or a `-from` parameter.
- Running the command with a `-db` parameter upgrades only the named databases, regardless of their current Oracle Database homes. If you include a `-from` parameter in addition to a `-db` parameter, then the command ignores the `-from` parameter. That is, the command upgrades named databases from other homes and ignores the databases in the named home if they are not listed in the `-db` parameter.
- Running the command without a `-db` parameter will upgrade all of the databases in the named Oracle Database home.
- You must always provide a `-to` parameter that names an existing Oracle Database home.

Example

Upgrade an Oracle 11.2.0.3.1 database named `tpcc` from Oracle Database 11.2.0.3.1 to Oracle Database 12.1.0.2 using the Oracle Database home directory `OraDb12102_home1`:

```
oakcli upgrade database -db tpcc -to OraDb12102_home1
```

5.31 oakcli validate

Validates the state of an Oracle Database Appliance or the viability of an operating system patch.

Syntax

```
oakcli validate [[-V | -l | -h]] | [[-v][-f output_file] [-a | -d | -c checklist][-ver patch_version]]
```

Parameters

Parameter	Description
-V	Display the version of oakValidation.

Parameter	Description
-l	List the items that can be checked (and their descriptions).
-h	(Optional) Display help for using the command.
-v	Show verbose output (must be used with a parameter that generates a validation report).
-f <i>output_file</i>	Send output to a file with a fully qualified file name, <i>output_file</i> , instead of to the screen (stdout).
-a	Run all system checks, including <code>DiskCalibration</code> . Oracle recommends that you use this command to validate system readiness before deployment. Do not run <code>oakcli validate</code> with this option on a busy production system, because the <code>DiskCalibration</code> system check can cause performance issues.
-d	Run only the default checks. The default checks are <code>NetworkComponents</code> , <code>OSDiskStorage</code> , <code>SharedStorage</code> , and <code>SystemComponents</code> . The <code>NetworkComponents</code> validation check is not available on Oracle Database Appliance V1.
-c <i>checklist</i>	Run the validation checks for the items identified in <i>checklist</i> , a comma-delimited list. Use this parameter to check either a single item or subset of items.
-c <i>ospatch</i>	Run the validation checks for the patch version identified in <code>-ver patch_version</code> .
-ver <i>patch_version</i>	Report any reasons for not being able to patch Oracle Database Appliance with the patch named in <i>patch_version</i> .

Listing All Checks and Their Descriptions

```
oakcli validate -l

Checkname -- Description
=====
*SystemComponents -- Validate system components based on ilom sensor data
readings
*OSDiskStorage -- Validate OS disks and filesystem information
*SharedStorage -- Validate Shared storage and multipathing information
DiskCalibration -- Check disk performance with orion
*NetworkComponents -- Validate public and private network components
*StorageTopology -- Validate external JBOD connectivity
asr -- Validate asr components based on asr config file and ilom sensor
data readings
```

* -- These checks are also performed as part of default checks

Running All Checks

Enter the following command to run all checks:

```
oakcli validate -a
```

Validating Storage Cable Connections

Check the cable connections between the system controllers and the storage shelf, as well as the cable connection to the storage expansion shelf (if one is installed):

```
oakcli validate -c storagetopology
```

Oracle recommends that you run the `oakcli validate -c StorageTopology` command *before* deploying the system. This will avoid and prevent problems during deployment due to wrong or missing cable connections. The output shown in the following example reports a successful configuration. If the cabling is not correct, you will see errors in your output.

```
# oakcli validate -c storagetopology
It may take a while. Please wait...
INFO : ODA Topology Verification
INFO : Running on Node0
INFO : Check hardware type
SUCCESS : Type of hardware found : X4-2
INFO : Check for Environment(Bare Metal or Virtual Machine)
SUCCESS : Type of environment found : Virtual Machine(ODA BASE)
SUCCESS : Number of External LSI SAS controller found : 2
INFO : Check for Controllers correct PCIe slot address
SUCCESS : External LSI SAS controller 0 : 00:15.0
SUCCESS : External LSI SAS controller 1 : 00:16.0
INFO : Check if powered on
SUCCESS : 1 : Powered-on
INFO : Check for correct number of EBODS(2 or 4)
SUCCESS : EBOD found : 2
INFO : Check for External Controller 0
SUCCESS : Controller connected to correct ebod number
SUCCESS : Controller port connected to correct ebod port
SUCCESS : Overall Cable check for controller 0
INFO : Check for External Controller 1
SUCCESS : Controller connected to correct ebod number
SUCCESS : Controller port connected to correct ebod port
SUCCESS : Overall Cable check for controller 1
INFO : Check for overall status of cable validation on Node0
SUCCESS : Overall Cable Validation on Node0
INFO : Check Node Identification status
SUCCESS : Node Identification
SUCCESS : Node name based on cable configuration found : NODE0
INFO : Check Nickname
SUCCESS : Nickname set correctly : Oracle Database Appliance - E0
INFO : The details for Storage Topology Validation can also be found in log
file=/opt/oracle/oak/log/<hostname>/storagetopology/
StorageTopology-2014-07-03-08:57:31_7661_15914.log
```

Validating Oracle ASR

Enter the following syntax to validate your Oracle ASR configuration:

```
# oakcli validate -c asr
INFO: oak Asr information and Validations
RESULT: /opt/oracle/oak/conf/asr.conf exist
RESULT: ASR Manager ip:10.139.154.17
RESULT: ASR Manager port:1162
SUCCESS: ASR configuration file validation successfully completed
RESULT: /etc/hosts has entry 141.146.156.46 transport.oracle.com
RESULT: ilom alertmgmt level is set to minor
RESULT: ilom alertmgmt type is set to snmptrap
RESULT: alertmgmt snmp_version is set to 2c
RESULT: alertmgmt community_or_username is set to public
RESULT: alertmgmt destination is set to 10.139.154.17
RESULT: alertmgmt destination_port is set to 1162
SUCCESS: ilom snmp configuration for asr set correctly
```

```
RESULT: notification trap configured to ip:10.139.154.17
RESULT: notification trap configured to port:1162
SUCCESS: Asr notification trap set correctly
INFO: IP_ADDRESS HOST_NAME SERIAL_NUMBER ASR PROTOCOL SOURCE PRODUCT_NAME
INFO: -----
-----
10.170.79.98 oda-02-c 1130FMW00D Enabled SNMP ILOM SUN FIRE X4370 M2 SERVER
10.170.79.97 oda-01-c 1130FMW00D Enabled SNMP ILOM SUN FIRE X4370 M2 SERVER
INFO: Please use My Oracle Support 'http://support.oracle.com' to view the
activation status.
SUCCESS: asr log level is already set to Fine.
RESULT: Registered with ASR backend.
RESULT: test connection successfully completed.
RESULT: submitted test event for asset:10.139.154.17
RESULT: bundle com.sun.svc.asr.sw is in active state
RESULT: bundle com.sun.svc.asr.sw-frag is in resolved state
RESULT: bundle com.sun.svc.asr.sw-rulesdefinitions is in resolved state
RESULT: bundle com.sun.svc.ServiceActivation is in active state
SUCCESS: ASR diag successfully completed
```

Checking the Viability of a Patch

Use the `oakcli validate ospatch -ver patch_version` command to report any reasons for not being able to patch Oracle Database Appliance with the patch named in *patch_version*. Run this command before you attempt to patch Oracle Database Appliance to determine if it will succeed or if you need to make changes before applying the patch.

```
# oakcli validate -c ospatch -ver 12.1.2.5.0
INFO: Validating the OS patch for the version 12.1.2.5.0
WARNING: 2015-10-10 06:30:32: Patching sub directory /opt/oracle/oak/pkgrepos/
orapkgs/OEL/5.10/Patches/5.10.1 is not existing
INFO: 2015-10-10 06:30:32: May need to unpack the Infra patch bundle for the
version: 12.1.2.5.0
ERROR: 2015-10-10 06:30:32: No OS patch directory found in the repository
```

Validating Hardware System and Network Components

The following command runs system checks to validate hardware system components and Oracle Database Appliance network components:

```
# oakcli validate -c SystemComponents,NetworkComponents
```

6

Validating and Troubleshooting Oracle Database Appliance

This chapter contains information about how to validate changes and troubleshoot Oracle Database Appliance problems.

Topics:

- [Oracle Database Appliance Diagnostics and Validation](#) (page 6-1)
Use `oakcli validate` to check your Oracle Database Appliance configuration, and if necessary, to provide information to Oracle Support Services.
- [Validate the Host Name](#) (page 6-5)
The host name at the log in prompt should be `oak1` for Node 0 and `oak2` for Node 1.
- [Oracle Database Appliance Configuration Error Messages](#) (page 6-6)
If you encounter errors while configuring Oracle Database Appliance, then review the following messages and actions:
- [Preparing Log Files for Oracle Support Services](#) (page 6-8)
If necessary, use the command `oakcli manage diagcollect` to collect diagnostic files to send to Oracle Support Services.
- [Additional Troubleshooting Tools and Commands](#) (page 6-8)
This section describes additional tools and commands for diagnosing and troubleshooting problems with Oracle Database Appliance.
- [Oracle Database Appliance Hardware Monitoring Tool](#) (page 6-10)
The Oracle Database Appliance Hardware Monitoring Tool displays the status of different hardware components in Oracle Database Appliance server nodes.

6.1 Oracle Database Appliance Diagnostics and Validation

Use `oakcli validate` to check your Oracle Database Appliance configuration, and if necessary, to provide information to Oracle Support Services.

The `oakcli validate` command is the Oracle Appliance Manager diagnostic and validation utility to identify and resolve support issues. If you experience problems with Oracle Database Appliance, then use the `oakcli validate` command options to verify that your environment is properly configured, and that best practices are in effect. When placing a service request, also use Oracle Appliance Manager as described in this chapter to prepare the log files to send to Oracle Support Services.

Topics:

- [Oracle Database Appliance Validation Command Overview](#) (page 6-2)
Use the `oakcli validate` command and options to validate the status of Oracle Database Appliance.
- [Examples of OAKCLI Validate Command Checks](#) (page 6-3)
Review these examples to see you can perform validation checks using the `oakcli validate` command and options.

6.1.1 Oracle Database Appliance Validation Command Overview

Use the `oakcli validate` command and options to validate the status of Oracle Database Appliance.

You must run the `oakcli validate` command as the `root` user.

Syntax

The command `oakcli validate` uses the following syntax, where *checklist* is a single check or a comma-delimited list of checks, and *output_file* is the name that you designate for a validation output file:

```
oakcli validate -h
oakcli validate [-V | -l | -h]
oakcli validate [-v] [-f output_file] [-a | -d | -c checklist] [-v patch_version]
```

Parameters

Option	Purpose
-a	Run all system checks, including <code>DiskCalibration</code> . Oracle recommends that you use this command to validate system readiness before deployment. Do not run <code>oakcli validate</code> with this option on a busy production system, because the <code>DiskCalibration</code> system check can cause performance degradation.
-c <i>checklist</i>	Run the validation checks for the items identified in <i>checklist</i> , a comma-delimited list. Use this parameter to check either a single item or subset of items.
-d	Run only the default checks. The default checks are <code>NetworkComponents</code> , <code>OSDiskStorage</code> , <code>SharedStorage</code> , and <code>SystemComponents</code> .
-f <i>output_file</i>	Send output to a file with a fully qualified file name, <i>output_file</i> , instead of to the screen (<code>stdout</code>).
-h	Display the online help.
-l	List the items that can be checked (and their descriptions).
-v	Show verbose output (must be used with a parameter that generates a validation report).
-V	Display the version of <code>oakValidation</code> .
-ver <i>patch_version</i>	Report any reasons for not being able to patch Oracle Database Appliance with the patch named in <i>patch_version</i> .

VALIDATE Options

Command	Purpose
-c <code>asr</code>	Validate Oracle Auto Service Request (Oracle ASR) components based on the Oracle ASR configuration file and Oracle Integrated Lights Out Manager (Oracle ILOM) sensor data.

Command	Purpose
-c DiskCalibration	Preinstallation check for the storage disk performance using <code>/opt/oracle/oak/bin/orion</code> Do not run this check after you have deployed Oracle software on Oracle Database Appliance, because running the <code>DiskCalibration</code> command on a deployed system creates performance issues. Use the default check option (<code>oakcli validate -d</code>) if you do not want to perform a system check for disk calibration.
-c NetworkComponents	Validate public and private network hardware connections.
-c OSDiskStorage	Validate the operating system disks, and file system information.
-c ospatch	Validate that the system can complete an upgrade successfully using the named patch.
-c SharedStorage	Validate shared storage and multipathing information.
-c StorageTopology	Validate the storage shelf connectivity.
-c SystemComponents	Validate system components, based on Oracle ILOM sensor data readings.

6.1.2 Examples of OAKCLI Validate Command Checks

Review these examples to see you can perform validation checks using the `oakcli validate` command and options.

Listing All Checks and Their Descriptions

```
oakcli validate -l

Checkname -- Description
=====
*SystemComponents -- Validate system components based on ilom sensor data
readings
*OSDiskStorage -- Validate OS disks and filesystem information
*SharedStorage -- Validate Shared storage and multipathing information
DiskCalibration -- Check disk performance with orion
*NetworkComponents -- Validate public and private network components
*StorageTopology -- Validate external JBOD connectivity
asr -- Validate asr components based on asr config file and ilom sensor
data readings

* -- These checks are also performed as part of default checks
```

Note:

The `NetworkComponents` validation check is not available on hardware prior to Oracle Database Appliance X3-2.

Running All Checks

Enter the following command to run all checks:

```
oakcli validate -a
```

Validating Storage Cable Connections

Check the cable connections between the system controllers and the storage shelf, as well as the cable connection to the storage expansion shelf (if one is installed):

```
oakcli validate -c storagetopology
```

Oracle recommends that you run the `oakcli validate -c StorageTopology` command before deploying the system. This will avoid and prevent problems during deployment due to wrong or missing cable connections. The output shown in the following example reports a successful configuration. If the cabling is not correct, you will see errors in your output.

```
# oakcli validate -c storagetopology
It may take a while. Please wait...
INFO : ODA Topology Verification
INFO : Running on Node0
INFO : Check hardware type
SUCCESS : Type of hardware found : X4-2
INFO : Check for Environment(Bare Metal or Virtual Machine)
SUCCESS : Type of environment found : Virtual Machine(ODA BASE)
SUCCESS : Number of External LSI SAS controller found : 2
INFO : Check for Controllers correct PCIe slot address
SUCCESS : External LSI SAS controller 0 : 00:15.0
SUCCESS : External LSI SAS controller 1 : 00:16.0
INFO : Check if powered on
SUCCESS : 1 : Powered-on
INFO : Check for correct number of EBODS(2 or 4)
SUCCESS : EBOD found : 2
INFO : Check for External Controller 0
SUCCESS : Controller connected to correct ebod number
SUCCESS : Controller port connected to correct ebod port
SUCCESS : Overall Cable check for controller 0
INFO : Check for External Controller 1
SUCCESS : Controller connected to correct ebod number
SUCCESS : Controller port connected to correct ebod port
SUCCESS : Overall Cable check for controller 1
INFO : Check for overall status of cable validation on Node0
SUCCESS : Overall Cable Validation on Node0
INFO : Check Node Identification status
SUCCESS : Node Identification
SUCCESS : Node name based on cable configuration found : NODE0
INFO : Check Nickname
SUCCESS : Nickname set correctly : Oracle Database Appliance - E0
INFO : The details for Storage Topology Validation can also be found in
log file=/opt/oracle/oak/log/<hostname>/storagetopology/
StorageTopology-2014-07-03-08:57:31_7661_15914.log
```

Validating Oracle ASR

Enter the following syntax to validate your Oracle ASR configuration:

```
# oakcli validate -c asr
INFO: oak Asr information and Validations
RESULT: /opt/oracle/oak/conf/asr.conf exist
RESULT: ASR Manager ip:10.139.154.17
RESULT: ASR Manager port:1162
SUCCESS: ASR configuration file validation successfully completed
RESULT: /etc/hosts has entry 141.146.156.46 transport.oracle.com
RESULT: ilom alertmgmt level is set to minor
```

```

RESULT: ilom alertmgmt type is set to snmptrap
RESULT: alertmgmt snmp_version is set to 2c
RESULT: alertmgmt community_or_username is set to public
RESULT: alertmgmt destination is set to 10.139.154.17
RESULT: alertmgmt destination_port is set to 1162
SUCCESS: Ilom snmp configuration for asr set correctly
RESULT: notification trap configured to ip:10.139.154.17
RESULT: notification trap configured to port:1162
SUCCESS: Asr notification trap set correctly
INFO: IP_ADDRESS HOST_NAME SERIAL_NUMBER ASR PROTOCOL SOURCE PRODUCT_NAME
INFO: -----
10.170.79.98 oda-02-c 1130FMW00D Enabled SNMP ILOM SUN FIRE X4370 M2 SERVER
10.170.79.97 oda-01-c 1130FMW00D Enabled SNMP ILOM SUN FIRE X4370 M2 SERVER
INFO: Please use My Oracle Support 'http://support.oracle.com' to view the
activation status.
SUCCESS: asr log level is already set to Fine.
RESULT: Registered with ASR backend.
RESULT: test connection successfully completed.
RESULT: submitted test event for asset:10.139.154.17
RESULT: bundle com.sun.svc.asr.sw is in active state
RESULT: bundle com.sun.svc.asr.sw-frag is in resolved state
RESULT: bundle com.sun.svc.asr.sw-rulesdefinitions is in resolved state
RESULT: bundle com.sun.svc.ServiceActivation is in active state
SUCCESS: ASR diag successfully completed

```

Checking the Viability of a Patch

Use the `oakcli validate ospatch -ver` command to report any reasons for not being able to patch Oracle Database Appliance with the patch named in `patch_version`. Run this command before you attempt to patch Oracle Database Appliance to determine if it succeeds or if you must make changes before applying the patch.

```

# oakcli validate -c ospatch -ver 12.1.2.5.0
INFO: Validating the OS patch for the version 12.1.2.5.0
WARNING: 2015-10-10 06:30:32: Patching sub directory /opt/oracle/oak/pkgrepos/
orapkgs/OEL/5.10/Patches/5.10.1 is not existing
INFO: 2015-10-10 06:30:32: May need to unpack the Infra patch bundle for the
version: 12.1.2.5.0
ERROR: 2015-10-10 06:30:32: No OS patch directory found in the repository

```

Validating Hardware System and Network Components

The following command runs system checks to validate hardware system components and Oracle Database Appliance network components:

```
# oakcli validate -c SystemComponents,NetworkComponents
```

6.2 Validate the Host Name

The host name at the log in prompt should be `oak1` for Node 0 and `oak2` for Node 1.

When a default manufacturing host name, such as `mtnk4t1-d05-01-host`, appears in the log in prompt instead of `oak1` or `oak2`, there is an issue that can cause problems when you configure Oracle Database Appliance.

The most likely cause of unexpected host names is that the storage cabling is incorrect or cables are not properly seated in the ports.

Verify the Storage Cabling for Oracle Database Appliance

Review the cabling instructions for your Oracle Database Appliance model and verify that the color-coded cables are in the correct ports. Also, verify that connections are secure. The SAS cables must be locked in place. Gently pull on each cable to confirm that it is properly seated. If you can pull the cable out, push it into the port until it clicks into place.

Verify the Storage Cabling for Models Earlier than X5-2

How you connect the storage tray to the appliance determines which Server is Node 0 and which is Node 1. This is important as all installation and configuring of software going forward is done from Node 0. In most cases the Server on the bottom is Node 0.

Ensure that the Node Files Exist and are Accurate

If the cabling appears to be correct and you still have unexpected host names, then confirm that the `/opt/oracle/oak/conf/node_num.conf` file exists for each node. Ensure that the `NODENUM` parameter is properly defined for each node. Set the parameter to `NODENUM=0` for Node 0 and `NODENUM=1` for Node 1. Create or edit the files, as needed.

6.3 Oracle Database Appliance Configuration Error Messages

If you encounter errors while configuring Oracle Database Appliance, then review the following messages and actions:

Error Encountered in Step 11 Validation VIP appears to be up on the network

Cause: This message is most likely to occur when you attempt to redeploy the End-User Bundle without cleaning up a previous deployment. This error occurs because an existing VIP is configured for the addresses assigned to Oracle Database Appliance.

Action: Run `cleanupDeploy.pl` on Node 0, and then restart Oracle Appliance Manager.

Error "CRS-4402: The CSS daemon was started in exclusive mode but found an active CSS daemon on node oda2-1, number 1, and is terminating"

Cause: This error occurs when the Oracle Grid Infrastructure CSS daemon attempts to start the node as a standalone cluster node, but during startup discovers that the other cluster node is running, and changes to cluster mode to join the cluster.

Action: Ignore this error.

Installation requires partitioning of your hard drive

Cause: This message occurs on a node if one of the two operating system disks is not installed, but you are attempting to reimage the operating system.

Action: Ensure that both operating system disks are installed and are available.

Machine Check Exception ...This is not a software problem

Cause: There is a hardware system error.

Action: Log in to the Oracle ILOM Remote Console to determine the specific hardware error.

No volume control GStreamer plug-ins and/or devices found

Cause: Operating system plug-ins required for sound cards for the Oracle ILOM remote redirection console are not installed.

Action: Ignore this message. You do not require volume control for the console.

Reboot and select proper boot device or insert boot media in selected boot device and press a key

Cause: One or both operating system disks are not available. This message occurs if you select "Default hard disk" during reimaging the system, but that disk is not available.

Action: Ensure that both operating system disks are installed and are available.

The AoDB Linux installation tree in that directory does not seem to match your boot media

Cause: If you select "Default (use BIOS settings)" as your imaging option, but one or both of the disks is not available, this message occurs on a node if both operating disks are installed, and you choose to reimage the operating system disks.

Action: Ensure that both operating system disks are available for use.

ERROR: Gateway IP is not pingable

Cause: On Windows platforms, the Oracle Appliance Manager configurator uses the echo service on port 7 to contact the gateway. If the echo service is disabled, possibly for security reasons, the ping fails.

Action: Run the native platform ping command. If the ping is successful, then the configurator validation output can be ignored.

ACFS resources failed to start after applying 2.2 INFRA patch

Cause: Oracle Database Appliance operating system upgrade includes upgrade of Oracle Linux to Unbreakable Enterprise Kernel (UEK). Because Oracle Automatic Storage Management Cluster File System (Oracle ACFS) is not supported on all versions of Oracle Linux, a successful upgrade of the operating system may effectively disable Oracle ACFS.

Upgrade to Oracle Database Appliance 2.2 has three options: `-infra`, `-gi`, and `-database`. The `-infra` option includes upgrade from Oracle Linux to UEK. Before the `-infra` upgrade to 2.2, the operating system is Oracle Linux with 11.2.0.2.x Grid Infrastructure. After the `-infra` upgrade, the operating system is UEK and 11.2.0.2.x Oracle ACFS, which is not compatible with UEK.

For example, upgrade to Oracle Linux 2.6.32-300.11.1.el5uek causes `reco.acfsvol.acfs` and `ora.registry.acfs` to temporarily go to an OFFLINE state, because 2.6.32-300.11.1.el5uek does not support Oracle 11.2.0.2.x ACFS. However, when Oracle Grid Infrastructure is upgraded to 11.2.0.3.2, these components are online again.

Action: Upgrade to Oracle Database Appliance 2.2 with the `-gi` option. This version of the software includes Oracle Grid Infrastructure 11.2.0.3.2, which includes Oracle ACFS modules that work with UEK.

For more information, see My Oracle Support note 1369107.1:

<https://support.oracle.com/CSP/main/article?cmd=show&type=NOT&id=1369107.1>

6.4 Preparing Log Files for Oracle Support Services

If necessary, use the command `oakcli manage diagcollect` to collect diagnostic files to send to Oracle Support Services.

If you have a system fault that requires help from Oracle Support Services, then you may need to provide log records to help Oracle support diagnose your issue.

Collect log file information by running the command `oakcli manage diagcollect`. This command consolidates information from log files stored on Oracle Database Appliance into a single log file for use by Oracle Support Services. The location of the file is specified in the command output.

6.5 Additional Troubleshooting Tools and Commands

This section describes additional tools and commands for diagnosing and troubleshooting problems with Oracle Database Appliance.

Although some of these tools are specific to Oracle Database Appliance, others are tools for all clustered systems.

Topics:

- [Oracle Appliance Manager Tools for Configuration Auditing and Disk Diagnosis](#) (page 6-8)
Oracle Appliance Manager provides access to a number of sophisticated monitoring and reporting tools, some of them derived from standalone tools that require their own syntax and command sets.
- [Trace File Analyzer Collector](#) (page 6-9)
Trace File Analyzer (TFA) Collector simplifies diagnostic data collection on Oracle Grid Infrastructure and Oracle Real Application Clusters systems.

6.5.1 Oracle Appliance Manager Tools for Configuration Auditing and Disk Diagnosis

Oracle Appliance Manager provides access to a number of sophisticated monitoring and reporting tools, some of them derived from standalone tools that require their own syntax and command sets.

The following list briefly describes the ORAchk command, and the disk diagnostic tool:

- ORAchk
The ORAchk Configuration Audit Tool audits important configuration settings for Oracle RAC two-node deployments in the following categories:
 - Operating system kernel parameters and packages
 - RDBMS
 - Database parameters, and other database configuration settings
 - Oracle Grid Infrastructure, which includes Oracle Clusterware and Oracle Automatic Storage Management

ORAchk is aware of the entire system. It checks the configuration to indicate if best practices are being followed. For example, ORAchk reviews the system and identifies best practice issues that are specific to Oracle Database Appliance when ORAchk is run by Oracle Appliance Manager. To explore ORAchk on Oracle Database Appliance, use the following command:

```
oakcli orachk -h
```

Also review My Oracle Support note 1268927.2, which is available from My Oracle Support.

- Disk Diagnostic Tool

Use the Disk Diagnostic Tool to help identify the cause of disk problems. The tool produces a list of 14 disk checks for each node. To run the tool, enter the following command:

```
# oakcli stordiag resource_type
```

 **See also:**

<https://support.oracle.com/CSP/main/article?cmd=show&type=NOT&id=1268927.2>

6.5.2 Trace File Analyzer Collector

Trace File Analyzer (TFA) Collector simplifies diagnostic data collection on Oracle Grid Infrastructure and Oracle Real Application Clusters systems.

TFA behaves in a similar manner to the ion utility packaged with Oracle Clusterware. Both tools collect and package diagnostic data. However, TFA is much more powerful than ion, because TFA centralizes and automates the collection of diagnostic information.

TFA provides the following key benefits and options:

- Encapsulation of diagnostic data collection for all Oracle Grid Infrastructure and Oracle RAC components on all cluster nodes into a single command, which you run from a single node
- Option to "trim" diagnostic files during data collection to reduce data upload size
- Options to isolate diagnostic data collection to a given time period, and to a particular product component, such as Oracle ASM, RDBMS, or Oracle Clusterware
- Centralization of collected diagnostic output to a single node in Oracle Database Appliance, if desired
- On-Demand Scans of all log and trace files for conditions indicating a problem
- Real-Time Scan Alert Logs for conditions indicating a problem (for example, Database Alert Logs, Oracle ASM Alert Logs, and Oracle Clusterware Alert Logs)

6.6 Oracle Database Appliance Hardware Monitoring Tool

The Oracle Database Appliance Hardware Monitoring Tool displays the status of different hardware components in Oracle Database Appliance server nodes.

The tool is implemented with the Trace File Analyzer collector. Use the tool both on bare-metal and on virtualized systems.

You can see the list of monitored components by running the command `oakcli show -h`

To see information about specific components, use the command syntax `oakcli show component`, where *component* is the hardware component that you want to query. For example, the command `oakcli show power` shows information specifically about the Oracle Database Appliance power supply:

```
oakcli show power
```

NAME	HEALTH	HEALTH DETAILS	PART_NO.	SERIAL_NO.	LOCATION
INPUT POWER	OUTPUT POWER	INLET TEMP	EXHAUST TEMP		
Power Supply_0	OK	-	7047410	476856F+1242CE0020	PS0
Present	88 watts	31.250 degree C	34.188 degree C		
Power Supply_1	OK	-	7047410	476856F+1242CE004J	PS1
Present	66 watts	31.250 degree C	34.188 degree C		



Note:

Oracle Database Appliance Server Hardware Monitoring Tool is enabled during initial startup of ODA_BASE on Oracle Database Appliance Virtualized Platform. When it starts, the tool collects base statistics for about 5 minutes. During this time, the tool displays the message "Gathering Statistics..." message.

The Oracle Database Appliance Hardware Monitoring Tool reports information only for the node on which you run the command. The information it displays in the output depend on the component that you select to review.

A

Oracle Database Appliance Software Configuration Defaults

Oracle Database Appliance software configuration defaults.

- [Directory Paths for Oracle Database Appliance](#) (page A-1)
Oracle homes on Oracle Database Appliance follow Optimal Flexible Architecture guidelines.
- [Oracle Groups and Users Configuration for Oracle Database Appliance](#) (page A-2)
Review the table to see the groups and default users created when you deploy the appliance. All passwords are set to the Master password that you define during deployment.
- [Database Disk Group Sizes for Oracle Database Appliance](#) (page A-2)
The tables in this section show the sizes for DATA, RECO, REDO, and FLASH disk groups on various configurations of Oracle Database Appliance.
- [Usable Storage on Oracle Database Appliance X5-2](#) (page A-4)
The table shows the usage storage available for various configurations of Oracle Database Appliance X5-2.
- [Storage on Oracle Database Appliance](#) (page A-6)
Review this section to understand Oracle Database Appliance storage architecture and options and how to determine usable storage.
- [System Configuration for Oracle Database Appliance](#) (page A-9)
Review to see the configuration options for Oracle Database Appliance.
- [Changing the Password](#) (page A-10)
Change the administrative account passwords to secure your system.

A.1 Directory Paths for Oracle Database Appliance

Oracle homes on Oracle Database Appliance follow Optimal Flexible Architecture guidelines.

Table A-1 Directory Paths for Oracle Database Appliance

Item	Directory Path
Grid home	<code>/u01/app/release-specific_name/grid</code>
Grid base	<code>/u01/app/grid</code>
Oracle home	<code>/u01/app/oracle/product/dbhome_release-specific_namesequence_number</code>
Oracle base	<code>/u01/app/oracle</code>
Oracle Inventory	<code>/u01/app/oraInventory</code>

A.2 Oracle Groups and Users Configuration for Oracle Database Appliance

Review the table to see the groups and default users created when you deploy the appliance. All passwords are set to the Master password that you define during deployment.

Oracle Groups and Users Configurations

Table A-2 Oracle Groups and Users Configuration for Oracle Database Appliance

Groups and Users	Default Value
Oracle Grid Infrastructure installation owner	grid, UID 1001
Oracle Database installation owner	oracle, UID 1000
Oracle Database system administrator	sys
Oracle Database generic administrator	system
Oracle Inventory system privileges group	oinstall, GID 1001
Oracle ASM Administrators system privileges	asmadmin, GID 1004
Oracle ASM Users system privileges	asmdba, GID 1006
Oracle ASM Operator system privileges	asmoper, GID 1005
Oracle Database Administrators system privileges	dba, GID 1003
Oracle Database Operator system privileges	dbaoper, GID 1002

A.3 Database Disk Group Sizes for Oracle Database Appliance

The tables in this section show the sizes for DATA, RECO, REDO, and FLASH disk groups on various configurations of Oracle Database Appliance.

Each table row has values for either normal or for high redundancy levels. The disk capacities shown in the tables vary, because they are derived by converting disk hardware terabytes (based on 1 kilobyte equals 1,000 bytes) into data storage terabytes (based on 1 kilobyte equals 1,024 bytes).

The space calculated with a storage expansion shelf approximately doubles the space mentioned in these tables.

 **Note:**

The storage expansion shelf can only be used with Oracle Database Appliance X5-2, X4-2, and X3-2.

Table A-3 Approximate Database Disk Group Sizes for Oracle Database Appliance X5-2

Sizing	X5-2 (GB), 4 TB	X5-2 (GB), 8 TB
HDD Size	3,816	7,631
Total HDD	61,056	122,096
Total SSD (REDO Disk Group)	744	744
Total SSD (FLASH Disk Group)	1,492	1,492
Total HDD with High Redundancy	20,352	40,699
Total HDD with Normal Redundancy	30,528	61,048
DATA Disk Group with High Redundancy - External Backup	15,315	30,626
RECO Disk Group with High Redundancy - External Backup	2,493	4,986
DATA Disk Group with High Redundancy - Local Backup	7,473	16,407
RECO Disk Group with High Redundancy - Local Backup	9,906	21,748
DATA Disk Group with Normal Redundancy - External Backup	24,513	49,220
RECO Disk Group with Normal Redundancy - External Backup	4,007	8,013
DATA Disk Group with Normal Redundancy - Local Backup	12,307	24,610
RECO Disk Group with Normal Redundancy - Local Backup	15,920	32,623
REDO Disk Group	248	248
FLASH Disk Group	746	746

 **Note:**

High Redundancy is triple-mirroring and Normal Redundancy is double-mirroring. The REDO Disk Group is always High Redundancy. The FLASH Disk Group is always Normal Redundancy.

Table A-4 Approximate Database Disk Group Sizes for Oracle Database Appliance Version 1, X3-2, and X4-2

Sizing	Version 1 (GB)	X3-2 (GB)	X4-2 (GB)
HDD Size	559	838	838
Total HDD	11,180	16,760	16,760
Total SSD (REDO Disk Group)	272	744	744
Total SSD (FLASH Disk Group)	N/A	N/A	N/A
Total HDD with High Redundancy	3,727	5,587	5,587
Total HDD with Normal Redundancy	5,590	8,380	8,380
DATA Disk Group with High Redundancy - External Backup	3,205	4,805	4,805
RECO Disk Group with High Redundancy - External Backup	522	782	782
DATA Disk Group with High Redundancy - Local Backup	1,603	2,402	2,402
RECO Disk Group with High Redundancy - Local Backup	2,124	3,185	3,185

Table A-4 (Cont.) Approximate Database Disk Group Sizes for Oracle Database Appliance Version 1, X3-2, and X4-2

Sizing	Version 1 (GB)	X3-2 (GB)	X4-2 (GB)
DATA Disk Group with Normal Redundancy - External Backup	4,807	7,207	7,207
RECO Disk Group with Normal Redundancy - External Backup	783	1,173	1,173
DATA Disk Group with Normal Redundancy - Local Backup	2,404	3,603	3,603
RECO Disk Group with Normal Redundancy - Local Backup	3,186	4,777	4,777
REDO Disk Group	91	248	248
FLASH Disk Group	N/A	N/A	N/A

 **Note:**

1. For non-CDB databases, the REDO disk group has 50% free disk space.
2. For CDB databases, an Oracle ACFS mount point is created per CDB database, based on the template log file size. If this is a Single Instance (SI) database, then multiply by 3. If this is an Oracle RAC database, then multiply by 4.
3. Accelerator volume size is 0.4% of the database DATA Oracle ACFS file system size and shared REPO Oracle ACFS file system size.

Related Topics

- [Managing Capacity in Disk Groups](#)

 **See Also:**

See the *Oracle Automatic Storage Management Administrator's Guide*, "Managing Capacity in Disk Groups" for more information about determining the amount of free space in your Oracle Database Appliance disk groups for Oracle ASM. The tables in this topic only provide the raw disk information.

A.4 Usable Storage on Oracle Database Appliance X5-2

The table shows the usage storage available for various configurations of Oracle Database Appliance X5-2.

The reserved storage is the amount of ASM storage required to maintain redundancy in the event of a disk failure. If you use the reserve storage capacity, then the system continues to run, and it is protected through ASM mirroring. However, in the event of a second disk failure, the system is then running in a non-protected and degraded mode. In this event, you must replace disks immediately. Refer to *Oracle Automatic Storage Management Administrator's Guide* for more information about ASM disk group capacity.

Table A-5 Usable Storage on Oracle Database Appliance X5-2

Sizing	Raw Value (GB)	Reserve (GB)	Usable (GB)
Total SSD (REDO Disk Group) (based on an estimated 190,780 GB) See the Note.	764	191	191
Total SSD (FLASH Disk Group) (based on an estimated 3,816 GB)	1,528	382	573
HDD Size: 8 TB	7,631		
External Backup/ Normal Redundancy (86%/14% split)			
DATA Disk Group with Normal Redundancy - External Backup	105,003	6,563	49,220
RECO Disk Group with Normal Redundancy - External Backup	17,093	1,068	8,013
External Backup/ High Redundancy			
DATA Disk Group with High Redundancy - External Backup	105,003	13,125	30,626
RECO Disk Group with High Redundancy - External Backup	17,093	2,137	4,986
Internal Backup/ Normal Redundancy (43%/57% split)			
DATA Disk Group with Normal Redundancy - Internal Backup	52,501	3,281	24,610
RECO Disk Group with Normal Redundancy - Internal Backup	69,595	4,350	32,623
Internal Backup/ High Redundancy			
DATA Disk Group with High Redundancy - Internal Backup	52,501	3,281	16,407
RECO Disk Group with High Redundancy - Internal Backup	69,595	4,350	21,748
HDD Size: 4 TB (Total: HDD Raw: 59,584 GB)	3,816		
External Backup/ Normal Redundancy (86%/14% split)			
DATA Disk Group with Normal Redundancy - External Backup	52,508	3,282	24,613
RECO Disk Group with Normal Redundancy - External Backup	8,548	534	4,007
External Backup/ High Redundancy			
DATA Disk Group with High Redundancy - External Backup	52,508	6564	15,315
RECO Disk Group with High Redundancy - External Backup	8,548	1,068	2,493
Internal Backup/ Normal Redundancy (43%/57% split)			
DATA Disk Group with Normal Redundancy - Internal Backup	26,254	1,641	12,307
RECO Disk Group with Normal Redundancy - Internal Backup	33,963	2,123	15,920
Internal Backup/ High Redundancy			
DATA Disk Group with High Redundancy - Internal Backup	25,621	3,203	7,473
RECO Disk Group with High Redundancy - Internal Backup	33,963	4,245	9,906

Related Topics

- [Administering Oracle ASM Disk Groups](#)

A.5 Storage on Oracle Database Appliance

Review this section to understand Oracle Database Appliance storage architecture and options and how to determine usable storage.

- [About Oracle Database Appliance Storage](#) (page A-6)
Oracle Database Appliance uses the Oracle Automatic Storage Management Cluster File System (Oracle ACFS) for storage of database and virtual machine files.
- [Oracle ACFS Mount Points and Storage Space](#) (page A-7)
Review Oracle ASM Cluster file system (ACFS) mount points for Oracle Database Appliance.
- [Oracle ACFS Space Management](#) (page A-8)
The Oracle ACFS file systems are automatically created when you create a database on Oracle Database Appliance.

A.5.1 About Oracle Database Appliance Storage

Oracle Database Appliance uses the Oracle Automatic Storage Management Cluster File System (Oracle ACFS) for storage of database and virtual machine files.

Oracle ACFS provides both servers with concurrent access to some or all of the shared storage on Oracle Database Appliance. Oracle ACFS supports space-efficient storage snapshots, which provides fast provisioning databases and virtual machines within Oracle Database Appliance.

Storage Systems Used With Oracle Database Appliance

Three types of Oracle ACFS file systems are used in Oracle Database Appliance:

- Database File Systems
- Shared repositories
- General-purpose storage

About Database File Systems

Database file systems are used exclusively for storing database files, and they include a FLASH file system for storing database data files and flash cache files, a DATA file system for database data files, a RECO file system for storing archive files and backups, and a REDO file system for storing redo log files.

About Shared Repositories

Shared repositories are file systems created on Oracle Database Appliance Virtualized Platform, and they are used to store virtual machine templates, runtime images, and virtual disks.

About General Purpose Storage

Every Oracle Database Appliance has a general-purpose cluster file system created by default. That cluster file system is named `cloudfs`. You can use the `cloudfs` file system for general-purpose storage of files that must be shared between the servers. For example, you can use the `cloudfs` file system for staging data loads.

All Oracle ACFS file systems are created on Oracle ASM Dynamic Volumes provisioned from disk groups that are created in the shared disk storage pool. In a bare-metal deployment, these file systems are mounted directly in the operating system hosting the databases. In a virtualized deployment, these file systems are managed and mounted directly in `ODA_BASE`.

A.5.2 Oracle ACFS Mount Points and Storage Space

Review Oracle ASM Cluster file system (ACFS) mount points for Oracle Database Appliance.

If you select Oracle Automatic Storage Management (Oracle ASM) for database storage when you create a database, then an Oracle ASM Cluster file system (ACFS) is not created. All files are in an Oracle ASM diskgroup.

If you select Oracle ACFS for database storage, then each database has its own Oracle ACFS mount point:

- DATA diskgroup: `/u02/app/oracleuser/oradata/db_name`
- RECO diskgroup: `/u03/app/oracleuser`.

With Oracle ACFS, the following are created:

- A 100G ACFS is created from +DATA diskgroup for each database. This Oracle ACFS automatically extends the space on demand.
- A common Oracle ACFS with 25% of +RECO diskgroup is created with auto extension on. This file system is used for fast recovery area and redo logs for all databases.

Table A-6 Oracle ACFS Mount Points and Related Oracle ASM Disk Groups and Volume Information

File System	Oracle ASM Disk Group	Oracle ASM Dynamic Volume	Mount Point
DATA	+DATA	<code>/dev/asm/datdbname-nnn</code> For example: <code>/dev/asm/datodacn-123</code>	<code>/u02/app/oracleuser/oradata/dbname</code> For example: <code>/u02/app/example/oradata/odacn</code>

Table A-6 (Cont.) Oracle ACFS Mount Points and Related Oracle ASM Disk Groups and Volume Information

File System	Oracle ASM Disk Group	Oracle ASM Dynamic Volume	Mount Point
RECO	+RECO	/dev/asm/reco- <i>nn</i>	<p>/u03/app/oracleuser</p> <p>This mount point is shared by all databases for <i>fast_recovery_area</i> and redo logs.</p> <p>For <i>fast_recovery_area</i>, the path is: /u03/app/oracleuser/<i>fast_recovery_area/db_name</i></p> <p>For redo logs, the path is: /u03/app/oracleuser/redo/<i>db_name</i></p>

Example A-1 Oracle ACFS Storage Space

When the Oracle ACFS file systems are created, they do not initially consume all of the storage in the appliance. Space is preserved for additional repositories, or in some cases, database files stored directly in Oracle ASM. You can check for available storage space in your file systems by running the operating system command `df -k` as shown in the following example.

```
# df -k
Filesystem                1K-blocks  Used    Available  Use%    /
Mounted on
/dev/mapper/VolGroupSys-LogVolRoot 30963708 14203568 15187276  49%    /
tmpfs                      65952292    647800  65304492
1% /dev/shm
/dev/sda1                   495844    43872   426372   10%    /
boot
/dev/mapper/VolGroupSys-LogVolOpt  61927420 18594420 40187272  32%    /
opt
/dev/mapper/VolGroupSys-LogVolU01 103212320 49621560 48347880  51%    /
u01
/dev/asm/reco-62            76546048 1469676  75076372
2% /u03/app/oracle
/dev/asm/datrdb2-268        104857600 3872368 100985232
4% /u02/app/oracle/oradata/rdb2
/dev/asm/datndb11-268      104857600 247160  104610440
1% /u02/app/oracle/oradata/ndb11
/dev/asm/datndb12-268      104857600 247160  104610440
1% /u02/app/oracle/oradata/ndb12
```

A.5.3 Oracle ACFS Space Management

The Oracle ACFS file systems are automatically created when you create a database on Oracle Database Appliance.

When you use Oracle ACFS for database storage, the following is created:

- A 100G ACFS is created from +DATA diskgroup for each database. This Oracle ACFS automatically extends the space on demand.

- A common Oracle ACFS with 25% of +RECO diskgroup is created with auto extension on. This file system is used for fast recovery area and redo logs for all databases.

When the Oracle ACFS file systems are created, they do not initially consume all of the storage in the appliance. Space is preserved for additional repositories, or in some cases, database files stored directly in Oracle ASM. You can check for available storage space in your file systems by running the operating system command `df -k` as shown in the following example.

```
# df -k
Filesystem                1K-blocks  Used    Available  Use%    /
Mounted on
/dev/mapper/VolGroupSys-LogVolRoot 30963708 14203568 15187276  49%    /
tmpfs                       65952292   647800  65304492
1% /dev/shm
/dev/sda1                   495844     43872   426372   10%    /
boot
/dev/mapper/VolGroupSys-LogVolOpt  61927420 18594420 40187272  32%    /
opt
/dev/mapper/VolGroupSys-LogVolU01 103212320 49621560 48347880  51%    /
u01
/dev/asm/reco-62            76546048  1469676  75076372
2% /u03/app/oracle
/dev/asm/datrd2-268         104857600  3872368 100985232
4% /u02/app/oracle/oradata/rdb2
/dev/asm/datndb11-268      104857600   247160 104610440
1% /u02/app/oracle/oradata/ndb11
/dev/asm/datndb12-268      104857600   247160 104610440
1% /u02/app/oracle/oradata/ndb12
```

A.6 System Configuration for Oracle Database Appliance

Review to see the configuration options for Oracle Database Appliance.

Table A-7 System Configuration for Oracle Database Appliance

Item	Value
Oracle Linux with the Red Hat-compatible kernel	Oracle Linux 6.9 with kernel-4.1.12-14.13.el6uek.x86_64
Oracle Database release	12.1.0.2.180116, 11.2.0.4.180116 Oracle Database Enterprise Edition, Oracle Database Standard Edition 2, Oracle Database Standard Edition 1, Oracle Database Standard Edition
SCAN port number	1521
Oracle Enterprise Edition DB control port	1158 To access Enterprise Manager , enter the following URL string, where <i>hostname</i> is the name of one of the Oracle Database Appliance server nodes: <code>https://hostname:1158/em</code>

A.7 Changing the Password

Change the administrative account passwords to secure your system.

During deployment, the `root` and database users `SYS`, `SYSTEM` and `PDBADMIN` are set to the master password. After deployment, the `oracle` and `grid` passwords are also set to the master password, which is `welcome1`.



Note:

Change the passwords to comply with your enterprise user security protocols.

Refer to the *Oracle Database Appliance Security Guide* and *Oracle Database Security Guide* for information about the required configuration and best practices to secure database systems.

B

Database Templates for Oracle Database Appliance

Use the information in this appendix to select database templates for your planned databases.

Topics:

- [Types of Database Templates for Oracle Database Appliance](#) (page B-1)
Choose a database template that best meets your database workload and hardware.

B.1 Types of Database Templates for Oracle Database Appliance

Choose a database template that best meets your database workload and hardware.

About Database Templates for Oracle Database Appliance

Oracle Database Appliance enables you to consolidate many databases into a single system. Consolidation can minimize idle resources, maximize efficiency, and lower costs. By using instance caging in conjunction with Oracle Database Resource Manager (the Resource Manager), you can provide desired levels of service across multiple instances on a single Oracle Database Appliance.

Oracle Database Appliance templates are already tuned for the size of each database instance workload. They are designed to run on a specific number of cores. Caging ensures that each database workload is restricted to the set of cores allocated by the template, enabling multiple databases to run concurrently with no performance degradation, up to the capacity of Oracle Database Appliance. You can select database template sizes larger than your current needs to provide for planned growth, which you accommodate later by adjusting System Global Area (SGA) and Program Global Area (PGA) sizes as well as the number of cores.

The Oracle Appliance Manager Configurator refers to the database sizing templates as *classes* of databases.

Note:

Oracle strongly recommends that you use the Oracle Database Appliance templates, because they implement best practices and are configured specifically for Oracle Database Appliance.

Use the following tables to help select the best templates for your databases. When using these tables remember that:

- The information in the tables assumes that you are creating disk backups. The information in the tables assume that you are creating local disk backups. Consider the space requirements for your database and the policy for local disk backups versus external backups. Typically, external backups have more space available for the database than local backups.
- Container databases are created on Oracle ACFS.
- I/O per second (I/Ops) values are derived from an 8-kilobyte random read-write response time of 10 to 12 milliseconds for Hard Disk Drives (HDDs), and less than 1 millisecond for Flash, for Oracle Database Appliance X5-2; 5 to 7 milliseconds for Oracle Database Appliance X4-2 and X3-2; and 5 milliseconds for Oracle Database Appliance Version 1 to service an online transaction processing (OLTP) I/O request. The rates are not based on the number of CPUs and assume that the system is running at capacity.
- Throughput, in megabytes per second (MBps) is based on a 1 MB sequential read/write for a data warehousing system. As with I/Ops, the MBps is a measure of throughput when the system is at capacity. With just a single small database running, the MBps would be the maximum available on the system for a large database.
- The log file size assumes four redo log groups for each instance with a log switch every 15 minutes when the system is running at full capacity.
- Storage is shared between the servers on Oracle Database Appliance.

About Improved Oracle Database Appliance Template Options

Oracle Appliance Manager provides improved database templates that are configured specifically for the type of database workload that you want to carry out on your databases on Oracle Database Appliance. Choose the template that best matches the common workload your databases perform (OLTP, DSS, In-Memory).

The improved Oracle Database templates replace the generic database templates from previous releases that only provided sizing parameters for OLTP workloads. The database sizing tables provide updated template names and sizing based on the number of CPUs and memory attributes for each type of database workload. The table "Oracle Database Appliance Database Template Name Conversions" provides a reference between the generic database template names and the database template names based on CPU cores.

Identify the template type that is appropriate to your database workload and hardware:

- Use Oracle Database Appliance OLTP Database Templates if your database workload is primarily online transaction processing (OLTP).
- Use Oracle Database Appliance DSS database templates if your database workload is primarily decision support services (DSS) or data warehousing.
- Use Oracle Database Appliance In-Memory (IMDB) database templates if your database workload can fit in memory, and can benefit from in-memory performance capabilities.
- Use Oracle Database Appliance X5-2 generic database templates if your database is on Oracle Database Appliance X5-2.
- Use Oracle Database Appliance X4-2 generic database templates if your database is on Oracle Database Appliance X4-2.

- Use Oracle Database Appliance X3-2 generic database templates if your database is on Oracle Database Appliance X3-2.
- Use Oracle Database Appliance Version 1 generic database templates if your appliance is the original model of Oracle Database Appliance.

The templates provide general guidelines about the maximum number of databases on a fully deployed Oracle Database Appliance. Base the memory and CPU sizing on the number of instances per server, not the number of databases. Memory and CPUs are shared by all databases and the number of databases impacts performance. For example, when you have one database, the database receives full I/O throughput. If you have 9 databases, then each database has only 1/9th of the available I/O throughput for all disks.

When you have multiple databases, they share and compete over available CPU resources. When choosing a template, do not have more CPU_COUNTs distributed than available threads in the system. Oracle recommends partitioning, where every database has exclusive CPUs. If you choose to exceed the recommended maximum number of databases on Oracle Database Appliance (over-provision), be aware of your I/O results and performance degradation. With the over-provisioned approach, the sum of the CPU_COUNT across all instances can exceed the number of CPUs. Better resource utilization is provided with over-provisioning; however, it is possible for contention to occur when multiple databases are heavily loaded at the same time. Over-provisioning is best used for systems running non-critical applications. Avoid using over-provisioning for databases with high I/O requirements or those with high transaction rates. If you choose to over-provision, then do not exceed twice the number of total CPUs. Twice the allocation of total CPUs is based on hyper-threading of 2 CPU threads per core.

Table B-1 Oracle Database Appliance Database Generic Template Name Conversions

CPU Core-Based Database Template Names	odb-01s	odb-01	odb-02	odb-04	odb-06	odb-12	odb-16	odb-24
Generic Database Template Names	Very, very small	Very Small	Small	Medium	Large	Extra Large	Extra Extra Large	Extra Extra Extra Large

 **Note:**

Extra Extra Large is applicable to Oracle Database Appliance X3-2 and Oracle Database Appliance X4-2. Extra Extra Extra Large is applicable to Oracle Database Appliance X4-2 only.

Table B-2 Oracle Database Appliance OLTP Database Template Sizes

Template	CPU Cores	SGA	PGA	Flash	Processes	LOG buffer, Redo Log
odb-01s (X5-2, X4-2, X3-2, and V1)	1	2 GB	1 GB	6 GB	200	16 MB, 1 GB
odb-01 (X5-2, X4-2, X3-2, and V1)	1	4 GB	2 GB	12 GB	200	16 MB, 1 GB

Table B-2 (Cont.) Oracle Database Appliance OLTP Database Template Sizes

Template	CPU Cores	SGA	PGA	Flash	Processes	LOG buffer, Redo Log
odb-02 (X5-2, X4-2, X3-2, and V1)	2	8 GB	4 GB	24 GB	400	16 MB, 1 GB
odb-04 (X5-2, X4-2, X3-2, and V1)	4	16 GB	8 GB	48 GB	800	32 MB, 1 GB
odb-06 (X5-2, X4-2, X3-2, and V1)	6	24 GB	12 GB	72 GB	1200	64 MB, 2 GB
odb-12 (X5-2, X4-2, X3-2, and V1)	12	48 GB	24 GB	144 GB	2400	64 MB, 4 GB
odb-16 (X5-2, X4-2, X3-2 Only)	16	64 GB	32 GB	192 GB	3200	64 MB, 4 GB
odb-24 (X5-2, X4-2 Only)	24	96 GB	48 GB	192 GB	4800	64 MB, 4 GB
odb-32 (X5-2 Only)	32	128 GB	64 GB	256 GB	6400	64 MB, 4 GB
odb-36 (X5-2 Only)	36	128 GB	64 GB	256 GB	7200	64 MB, 4 GB



Note:

Flash is applicable to Oracle Database Appliance X5-2 only.

Table B-3 Oracle Database Appliance DSS Database Template Sizes

Template	CPU Cores	SGA (GB)	PGA (GB)	Processes	Redo log file size (GB)	Log buffer (MB)
odb-01s (X5-2, X4-2, X3-2, and V1)	1	1	2	200	1	16
odb-01 (X5-2, X4-2, X3-2, and V1)	1	2	4	200	1	16
odb-02 (X5-2, X4-2, X3-2, and V1)	2	4	8	400	1	16
odb-04 (X5-2, X4-2, X3-2, and V1)	4	8	16	800	1	32
odb-06 (X5-2, X4-2, X3-2, and V1)	6	12	24	1200	2	64
odb-12 (X5-2, X4-2, X3-2, and V1)	12	24	48	2400	4	64
odb-16 (X5-2, X4-2, X3-2 Only)	16	32	64	3200	4	64
odb-24 (X5-2, X4-2 Only)	24	48	96	4800	4	64
odb-32 (X5-2 Only)	32	64	128	6400	4	64
odb-36 (X5-2 Only)	36	64	128	7200	4	64

Table B-4 Oracle Database Appliance In-Memory Database Template Size

Template	CPU Cores	SGA (GB)	PGA (GB)	In-Memory (GB)	Processes	Redo log file size (GB)	Log buffer (MB)
odb-01s (X5-2, X4-2, X3-2, and V1)	1	2	1	1	200	1	16
odb-01 (X5-2, X4-2, X3-2, and V1)	1	4	2	2	200	1	16
odb-02 (X5-2, X4-2, X3-2, and V1)	2	8	4	4	400	1	16
odb-04 (X5-2, X4-2, X3-2, and V1)	4	16	8	8	800	1	32
odb-06 (X5-2, X4-2, X3-2, and V1)	6	24	12	12	1200	2	64
odb-12 (X5-2, X4-2, X3-2, and V1)	12	48	24	24	2400	4	64
odb-16 (X5-2, X4-2, X3-2 Only)	16	64	32	32	3200	4	64
odb-24 (X5-2, X4-2 Only)	24	96	48	48	4800	4	64
odb-32 (X5-2 Only)	32	128	64	64	6400	4	64
odb-36 (X5-2 Only)	36	128	64	64	7200	4	64

Table B-5 Oracle Database Appliance X5-2 Database Template Size Storage Performance

Template	Number of databases that you can deploy using this template	Container Database ACFS Size on DATA Disk Group (GB)	I/Ops with single storage shelf (HDD/FLASH)	Throughput (MBps) with single storage shelf (HDD/FLASH)	I/Ops with storage shelf plus storage expansion shelf (HDD/FLASH)	Throughput (MBps) with storage shelf plus storage expansion shelf (HDD/FLASH)	Log generation (MBps)
odb-01s	36	100	42/4167	83/83	83/8333	167/167	6.83
odb-01	36	100	42/4167	83/83	83/8333	167/167	6.83
odb-02	18	200	83/8.3K	167/167	167/16.7K	333/333	6.83
odb-04	9	400	167/16.7K	333/333	333/33.3K	667/667	13.65
odb-06	6	800	250/25K	500/500	500/50K	1000/1000	27.3
odb-12	3	1600	500/50K	1000/1000	1000/100K	2000/2000	27.3
odb-16	2	1600	750/75K	1500/1500	1500/150K	3000/3000	27.3
odb-24	1	1600	1500/150K	3000/3000	3000/300K	6000/6000	27.3
odb-32	1	1600	1500/150K	3000/3000	3000/300K	6000/6000	27.3
odb-36	1	1600	1500/150K	3000/3000	3000/300K	6000/6000	27.3



Note:

The number of databases that you can deploy using this template is for the entire Oracle Database Appliance.

Actual I/O per second (I/Ops) and throughput for a database depends on the percentage of I/O operations that are serviced through the FLASH, compared with the operations serviced through the hard disk drives (HDDs). The I/Ops weighting in these tables assumes an OLTP workload calculated as a mixed workload (80 percent reads, serviced through the FLASH cache, and 20 percent writes serviced through the HDDs).

Table B-6 Oracle Database Appliance X4-2 Database Template Size Storage Performance

Template	Number of databases that you can deploy using this template	Container Database ACFS Size on DATA Disk Group (GB)	I/Ops with single storage shelf	Throughput (MBps) with single storage shelf	I/Ops with storage shelf plus storage expansion shelf	Throughput (MBps) with storage shelf plus storage expansion shelf	Log generation (MBps)
odb-01s	24	100	138	146	275	229	6.83
odb-01	24	100	138	146	275	230	6.83
odb-02	12	200	275	292	550	458	6.83
odb-04	6	400	550	583	1100	917	13.65
odb-06	4	800	825	875	1650	1375	27.3
odb-12	2	1600	1650	1750	3300	2750	27.3
odb-16	1	1600	3300	3500	6600	5500	27.3
odb-24	1	1600	3300	3500	6600	5500	27.3

Table B-7 Oracle Database Appliance X3-2 Database Template Size Storage Performance

Template	Number of databases that you can deploy using this template	Container Database ACFS Size on DATA Disk Group (GB)	I/Ops with single storage shelf	Throughput (MBps) with single storage shelf	I/Ops with storage shelf plus storage expansion shelf	Throughput (MBps) with storage shelf plus storage expansion shelf	Log generation (MBps)
odb-01s	16	100	206	219	413	344	6.83
odb-01	16	100	206	219	413	344	6.83
odb-02	8	200	413	438	825	688	6.83
odb-04	4	400	825	875	1650	1375	13.65
odb-06	2	800	1650	1750	3300	2750	27.3
odb-12	1	1600	3300	3500	6600	5500	27.3
odb-16	1	1600	3300	3500	6600	5500	27.3

Table B-8 Oracle Database Appliance Version 1 Database Template Size Storage Performance

Template	Number of databases that you can deploy using this template	Container Database ACFS Size on DATA Disk Group (GB)	I/Ops	Throughput (MBps)	Log generation (Mps)
odb-01s	12	100	333	250	6.83
odb-01	12	100	333	250	6.83
odb-02	6	200	667	500	6.83
odb-04	3	400	1333	1000	13.65
odb-06	2	800	2000	1500	27.3
odb-12	1	1600	4000	3000	27.3

 **Note:**

For a single database, select a template that best fits your expected workload (the CPU and I/Ops capabilities you require) on the hardware that you are using. When creating multiple databases, calculate the overall workload; available system resources for any new database are affected by the CPU and I/Ops consumed by the existing databases that are already on the system.

Index

Numerics

10-GbE network interface, [4-46](#)

A

about deploying, [4-7](#)

ACFS, [A-6–A-8](#)

ACFS mount points, [A-7](#)

administrative account users, [2-5](#)

administrative accounts, [2-5](#)

ASM Cluster File System

See Oracle ACFS

ASR

See Oracle ASR (Auto Service Request)

Automatic Storage Management

See Oracle ASM

B

backup and recovery

 RMAN, [2-3](#)

bare metal restore, [1-16](#)

bond

 network interface, [4-46](#)

bridge

 network interface, [4-46](#)

C

caching database data, [2-12](#)

cleaning up deployment, [6-6](#)

cloudfs

 display file systems, [5-60](#)

Cluster Health Monitor

 collect diagnostic data, [5-43](#)

component version

 display, [5-75](#)

Configuration Audit Tool (ORAchk), [6-8](#)

configure virtual machine, [4-41](#)

controllers

 display details, [5-64](#)

convert single instance database

 to Oracle RAC, [2-9](#)

 to Oracle RAC One Node, [2-9](#)

cooling

 show status, [5-53](#)

cores

 display how allocated to virtual machines,
 [5-54](#)

CPU

 caging, [4-42](#)

 display details, [5-54](#)

 display processor details, [5-62](#)

CPU core

 current configuration, [5-38](#)

CPU pool, [4-42](#)

 default-unpinned-pool, [4-42](#)

 over-subscribed, [4-44](#)

D

database, [2-9](#), [B-1](#)

 configuration file, [2-7](#)

 remove, [2-7](#)

 view contents, [2-7](#)

 consolidate multiple, [B-1](#)

 display file systems, [5-60](#)

 home, [2-9](#)

 create multiple, [2-9](#)

 multiple, [2-9](#)

 managing and maintaining, [2-1](#)

 upgrade, [2-14](#)

database configuration

 display parameters, [5-55](#)

database configuration file

 create, [5-28](#)

 delete, [5-33](#)

database snapshot, [2-8](#)

 create, [5-30](#)

database storage, [A-6](#)

database template

 See template, database

database templates, [B-1](#)

dbhome

 delete, [5-34](#)

default groups and users, [A-2](#)

DHCP (Dynamic Host Configuration Protocol)

 initial network, [5-14](#)

directory paths, [A-1](#)

disk
 display details, [5-57](#)
 disk controllers
 display details, [5-53](#)
 disk diagnostic tool, [6-8](#)
 disk group sizes, [A-2](#)
 disk storage
 display details, [5-64](#)
 domain
 definition, [4-4](#)
 Domain 0 (Dom0)
 definition, [4-3](#)
 Domain U
 definition, [4-3](#)
 driver domain virtual machine
 about, [4-31](#)
 Dynamic Host Configuration Protocol
 See DHCP

E

EM Express, [2-3](#)
 Enterprise Manager plug-in, [2-3](#)
 errors
 display validation, [5-64](#)
 expander
 display information, [5-59](#)
 error detection, [5-59](#)
 expanders
 display details, [5-64](#)

F

failures
 display validation, [5-65](#)
 firmware
 display version, [5-66](#)
 invalid version failure, [5-64](#), [5-65](#)
 patching, [5-75](#)
 flash storage, [2-12](#)

G

Grid user, [2-5](#)
 group user
 change name or ID, [5-37](#)
 groups and users defaults, [A-2](#)
 Guest Domains (Domain U)
 definition, [4-3](#)
 guest virtual machine
 definition, [4-4](#)

H

high availability, [4-41](#)

HRD tool, [6-8](#)

I

InfiniBand
 display details, [5-60](#)
 display port, [5-60](#)
 installation owner
 grid, [A-10](#)
 oracle, [A-10](#)
 password, [A-10](#)
 instance caging, [2-11](#)
 enable, [2-11](#)
 template, [B-1](#)
 ISO
 downloading, [1-16](#)

K

kernel parameters
 adjust after memory upgrade, [5-47](#)

L

LED
 physical disk identifier, [5-42](#)
 Linux
 and virtualization, [4-2](#)
 local disk
 display details, [5-60](#)
 local repository, [4-15](#)
 log files
 sending to Oracle Support Services, [6-8](#)
 log switch
 select template, [B-1](#)

M

manual database updates, [2-15](#), [2-16](#)
 manual database upgrades, [2-18](#)
 master node
 command, [5-60](#)
 memory module
 display details, [5-61](#)
 migration
 from an existing database, [2-3](#)
 multiple database instances
 instance caging, [2-11](#)
 multiple Oracle homes, [2-9](#)
 create, [2-9](#)
 My Oracle Support, [6-8](#)
 send log files for troubleshooting, [6-8](#)

N

network

display details, [5-61](#)

network infrastructure, [4-46](#)

network interface

default values, [4-46](#)

O

oakcli

show cooling, [5-53](#)

oakcli commands, [4-7](#)

-driverdomain, [4-22](#)

-repo parameter, [4-21](#)

-snap, [4-21](#), [4-22](#)

-vm, [4-22](#)

-vmtemplate, [4-21](#)

add disk -local, [5-6](#)

apply, [5-7](#)

clone, [5-8](#)

clone vdisk, [4-13](#), [5-8](#)

clone vm, [4-21](#), [4-22](#), [5-9](#)

clones and snap clones, [4-20](#)

configure, [5-11](#)

configure additionalnet, [5-12](#)

configure ASR, [5-12](#)

configure cpupool, [4-45](#), [5-13](#)

configure firstnet, [5-14](#)

configure ib2fiber, [5-14](#)

configure network, [5-15](#)

configure networks, [5-12](#)

configure oda_base, [5-15](#)

configure ODA_BASE, [4-52](#)

configure repo, [4-12](#), [5-16](#)

configure vm, [4-18](#), [4-19](#), [4-41](#), [4-45](#), [4-46](#),
[5-17](#)

configure vmtemplate, [4-18](#), [4-19](#), [5-19](#)

copy, [5-21](#)

create, [5-21](#)

db_config_params, [5-28](#)

dbhome, [2-18](#)

create cpupool, [4-44](#), [5-22](#)

create database, [2-7](#), [2-9](#), [5-23](#)

create db_config_params, [2-7](#)

create dbhome, [5-26](#)

create dbstorage, [5-27](#)

create repo, [4-9](#), [5-29](#)

create vdisk, [4-12](#)

create vlan, [4-49](#), [5-31](#)

delete, [5-32](#)

delete cpupool, [5-33](#)

delete database, [5-33](#)

delete db_config_params, [2-7](#), [5-33](#)

delete dbhome, [5-34](#)

oakcli commands (*continued*)

delete dbstorage, [5-34](#)

delete repo, [4-11](#), [5-35](#)

delete vdisk, [4-14](#)

delete vlan, [4-49](#), [5-36](#)

delete vm, [5-36](#)

delete vmtemplate, [4-20](#), [5-36](#)

deploy

change group name and ID, [5-37](#)

log file, [5-37](#)

describe-cpucore, [5-38](#)

diskwritocache, [5-40](#)

expand storage, [5-39](#)

import vmtemplate, [4-17](#), [5-40](#)

locate, [5-42](#)

manage diagcollec, [6-8](#)

manage diagcollect, [5-42](#)

migrate vm, [5-43](#)

modify, [5-44](#)

modify database, [5-44](#)

modify vm, [4-14](#), [4-49](#), [5-45](#)

-addnetwork parameter, [4-49](#)

modify vmtemplate, [5-46](#)

oakcli create db_config_params, [5-28](#)

oakcli create snapshotdb, [5-30](#)

oakcli create vdisk, [5-30](#)

oakcli delete vdisk, [5-35](#)

oakcli oakcli show ib, [5-60](#)

oakcli show dbstorage, [5-56](#)

oakcli show fs, [5-60](#)

oakcli show iraid, [5-60](#)

oakcli show vmconsole, [5-69](#)

orachk, [5-46](#)

reconfigure kernel parameters, [5-47](#)

reconfigure memlock, [5-47](#)

reconfigure osparams, [5-47](#)

reconfigure vm.nearhugepage, [5-47](#)

resize dbstorage, [5-49](#)

restart oda_base, [5-49](#)

restart ODA_BASE, [4-52](#)

show, [5-50](#)

databases, [1-13](#), [2-15](#), [2-16](#)

dbhome, [2-18](#)

show -h

with Oracle Database Appliance

Hardware Monitoring Tool, [6-10](#)

show asr, [5-52](#)

show controller, [5-53](#)

show core_config_key, [5-54](#)

show cpupool, [4-44](#), [5-54](#)

show databases, [5-55](#)

show db_config_params, [2-7](#), [5-55](#)

show dbhomes, [5-56](#)

show disk, [5-57](#)

show diskgroup, [5-58](#)

- oakcli commands (*continued*)
 - show enclosure, [5-59](#)
 - show env_hw, [5-59](#)
 - show expander, [5-59](#)
 - show ismaster, [5-60](#)
 - show memory, [5-61](#)
 - show network, [5-61](#)
 - show power, [5-61](#)
 - example, [6-10](#)
 - show processor, [5-62](#)
 - show raidsyncstatus, [5-62](#)
 - show repo, [4-10](#), [5-63](#)
 - show server, [5-64](#)
 - show storage, [5-64](#)
 - show validation storage, [5-64](#)
 - show validation storage errors, [5-64](#)
 - show validation storage failures, [5-65](#)
 - show vdisk, [4-13](#), [5-65](#)
 - show version, [1-14](#), [5-66](#)
 - show vlan, [4-49](#), [5-67](#)
 - show vm, [5-68](#)
 - show vmtemplate, [4-16](#), [4-19](#), [5-70](#)
 - start, [5-70](#)
 - start oda_base, [5-71](#)
 - start repo, [4-10](#), [5-71](#)
 - start vm, [4-28](#), [5-71](#)
 - stop, [5-72](#)
 - stop repo, [4-11](#)
 - stop vm, [4-28](#)
 - stordiag, [5-73](#), [6-8](#)
 - test asr, [5-74](#)
 - unpack, [5-74](#)
 - update, [1-13](#), [2-15](#), [2-16](#), [5-75](#)
 - upgrade, [5-76](#)
 - upgrade database, [2-18](#)
 - validate, [5-77](#), [6-1–6-3](#)
 - validate -c ospatch, [1-9](#)
- OAKCLI commands
 - create database, [2-6](#)
- oakcli deploy, [5-37](#)
- ODA_BASE
 - caging, [4-42](#)
 - definition, [4-3](#)
 - Dom1, [4-7](#)
 - domain, [4-42](#)
 - resize, [4-52](#)
 - resizing, [4-52](#)
 - VLAN management, [4-49](#)
- odarepo1
 - local repository, [4-15](#)
- odarepo2
 - local repository, [4-15](#)
- OINSTALL group, [2-5](#)
- Optimal Flexible Architecture and Oracle homes, [A-1](#)
- ORAchk, [6-8](#)
- Oracle ACFS, [4-4](#)
 - display database storage information, [5-56](#)
- Oracle ACFS (Oracle Automatic Storage Management Cluster File System)
 - shared repository, [4-4](#)
- Oracle Appliance Kit
 - Command-Line Interface
 - Database management, [2-1](#)
- Oracle Appliance Manager command-line interface
 - alphabetical list of commands, [5-1](#)
 - help for, [5-3](#)
 - location of, [5-3](#)
 - uses for, [5-3](#)
- Oracle Appliance Manager command-line-interface
 - operational notes, [5-3](#)
- Oracle ASM (Oracle Automatic Storage Management)
 - configuration check, [6-8](#)
 - data migration, [2-3](#)
 - physical disk identifier, [5-42](#)
 - trace file analyzer diagnostics, [6-9](#)
 - user group, [A-2](#)
- Oracle ASM disk group
 - display details, [5-58](#)
- Oracle ASR (Auto Service Request), [5-74](#)
 - configure, [5-12](#)
 - display configuration details, [5-52](#)
 - test asr, [5-74](#)
- Oracle Automatic Storage Management
 - See Oracle ASM
- Oracle Clusterware
 - description, [2-4](#)
- Oracle Database, [2-9](#), [B-1](#)
 - upgrading, [1-13](#)
 - See also database
- Oracle Database Appliance Hardware Monitoring Tool, [6-10](#)
- Oracle Database Appliance Virtualized Platform and oakcli, [5-3](#)
- Oracle Database Resource Manager
 - instance caging, [2-11](#)
- Oracle DBCA (Oracle Database Configuration Assistant)
 - add database, [2-4](#)
 - convert database, [2-9](#)
 - drop database, [2-4](#)
- Oracle Enterprise Manager Database Express, [2-3](#)
- Oracle home
 - multiple, [2-9](#)
- Oracle RAC (Oracle Real Application Clusters), [6-8](#)

- Oracle RAC (Oracle Real Application Clusters) (*continued*)
- check configuration settings, [6-8](#)
 - convert single-instance database to, [2-9](#)
 - description, [2-4](#)
 - Oracle Clusterware, [2-4](#)
 - trace file analyzer, [6-9](#)
- Oracle RAC One Node
- convert single instance database to, [2-9](#)
 - description, [2-4](#)
- Oracle Real Application Clusters
- See Oracle RAC
- Oracle Support Services
- See My Oracle Support
- Oracle user, [2-5](#)
- Oracle VM, [4-2](#)
- OSASM group, [2-5](#)
- OSDBA, [2-5](#)
- OSDBA for ASM group, [2-5](#)
- OSDBA group, [2-5](#)
- OSOPER groups, [2-5](#)
- over-subscribed CPU pool, [4-44](#)
- ## P
-
- password
- changing, [A-10](#)
- patch bundle, [1-1](#)
- unpack, [1-8](#)
- patching, [1-1](#)
- Oracle Database, [1-13](#)
 - validating patches, [1-9](#)
- patching, downloading patch bundle, [1-7](#)
- performance, [2-12](#)
- performance tuning, [4-44](#), [4-45](#)
- physical disk
- LED identifier, [5-42](#)
- power supply
- display details, [5-61](#)
- ## R
-
- RAID
- display details, [5-60](#)
- raidsyncstatus
- display, [5-62](#)
- re-imaging
- bare metal, [1-16](#)
- Real Application Clusters
- See Oracle RAC
- redo log writes
- and SSDs, [2-12](#)
- reimaging
- bare metal, [1-16](#)
- resource management
- CPU pools, [4-44](#)
 - resource management (*continued*)
 - Oracle VM, [4-2](#)
 - supported virtual operating systems, [4-2](#)
- RMAN (Recovery Manager utility)
- database management, [2-3](#)
- ## S
-
- SAS expander
- display details, [5-59](#)
- SCAN (single client access name)
- system configuration, [A-9](#)
- sending log files to Oracle Support Services, [6-8](#)
- server
- display details, [5-64](#)
- shared repositories
- about, [4-4](#)
 - architecture, [4-4](#)
- shared repository
- creating and managing, [4-9](#)
 - delete, [5-35](#)
 - deleting, [4-11](#)
 - increasing the size, [4-12](#)
 - show status, [4-10](#)
 - starting, [4-10](#)
 - stopping, [4-11](#)
- single client access name
- See SCAN
- single instance database
- convert to Oracle RAC or Oracle RAC One Node, [2-9](#)
- snapshot database, [2-8](#)
- software
- installation troubleshooting, [6-6](#)
- Solaris x86
- and virtualization, [4-2](#)
- space management, [A-7](#), [A-8](#)
- SQL*Loader, [2-3](#)
- SRVCTL (server control utility)
- add and remove database, [2-4](#)
- SSDs, [2-12](#)
- storage, [3-1](#)
- show enclosure subsystem, [5-59](#)
- storage expansion
- command, [5-39](#)
- ## T
-
- template
- database
 - choosing, [B-1](#)
 - virtual machine
 - automatic unique naming, [4-15](#)
 - unique name for each node, [4-15](#)
- templates, [B-1](#)

Trace File Analyzer utility, [6-9](#)

troubleshooting

- AoDB Linux installation tree, [6-6](#)
- expander, [5-59](#)
- hrd disk diagnostic tool, [6-9](#)
- log files for Oracle Support Services, [6-8](#)
- machine check exception, [6-6](#)
- partitioning hard drive, [6-6](#)
- performance issues, [6-2](#)
- preinstallation deployment checks, [6-2](#)
- software installation, [6-6](#)
- system startup, [6-6](#)
- trace file analyzer, [6-9](#)

U

upgrade database, [2-14](#)

upgrading

- Oracle Database, [1-13](#)

V

validation errors

- display, [5-64](#)

validation failures

- display, [5-65](#)

virtual disk

- attaching to a virtual machine, [4-14](#)
- cloning, [4-13](#)
- create, [5-30](#)
- creating, [4-12](#)
- delete, [5-35](#)
- deleting, [4-14](#)
- display details, [5-65](#)
- viewing information about, [4-13](#)

virtual disks, [4-4](#)

virtual local area network, [4-46](#)

- assigning to ODA_BASE, [4-49](#)
- assigning to user domain, [4-49](#)
- create, [4-49](#)
- native, [4-49](#)
- on ODA_BASE, [4-49](#)
- on user domains, [4-49](#)
- removing from ODA_BASE, [4-49](#)
- removing from user domain, [4-49](#)

virtual machine

- about, [4-4](#), [4-31](#)
- assemblies, [4-4](#)
- caging, [4-42](#)
- display repository details, [5-63](#)
- high availability, [4-41](#)
- ODA_BASE caging, [4-42](#)
- open console, [5-69](#)
- pin, [4-42](#)
- template, [4-15](#)
- templates, [4-4](#), [4-31](#)

virtual machine templates

- importing, [4-17](#)
- listing, [4-16](#)

virtualization, [4-2](#), [4-7](#)

VLAN

- display details, [5-67](#)

vm templates

- display details, [5-70](#)

W

web interface

- Oracle Enterprise Manager Database Express, [2-3](#)

Windows

- and virtualization, [4-2](#)