

# Oracle® Database Appliance Service Manual



E94177-02  
June 2018



Oracle Database Appliance Service Manual,

E94177-02

Copyright © 2018, Oracle and/or its affiliates. All rights reserved.

Primary Author: Ralph Woodley

This software and related documentation are provided under a license agreement containing restrictions on use and disclosure and are protected by intellectual property laws. Except as expressly permitted in your license agreement or allowed by law, you may not use, copy, reproduce, translate, broadcast, modify, license, transmit, distribute, exhibit, perform, publish, or display any part, in any form, or by any means. Reverse engineering, disassembly, or decompilation of this software, unless required by law for interoperability, is prohibited.

The information contained herein is subject to change without notice and is not warranted to be error-free. If you find any errors, please report them to us in writing.

If this is software or related documentation that is delivered to the U.S. Government or anyone licensing it on behalf of the U.S. Government, then the following notice is applicable:

U.S. GOVERNMENT END USERS: Oracle programs, including any operating system, integrated software, any programs installed on the hardware, and/or documentation, delivered to U.S. Government end users are "commercial computer software" pursuant to the applicable Federal Acquisition Regulation and agency-specific supplemental regulations. As such, use, duplication, disclosure, modification, and adaptation of the programs, including any operating system, integrated software, any programs installed on the hardware, and/or documentation, shall be subject to license terms and license restrictions applicable to the programs. No other rights are granted to the U.S. Government.

This software or hardware is developed for general use in a variety of information management applications. It is not developed or intended for use in any inherently dangerous applications, including applications that may create a risk of personal injury. If you use this software or hardware in dangerous applications, then you shall be responsible to take all appropriate fail-safe, backup, redundancy, and other measures to ensure its safe use. Oracle Corporation and its affiliates disclaim any liability for any damages caused by use of this software or hardware in dangerous applications.

Oracle and Java are registered trademarks of Oracle and/or its affiliates. Other names may be trademarks of their respective owners.

Intel and Intel Xeon are trademarks or registered trademarks of Intel Corporation. All SPARC trademarks are used under license and are trademarks or registered trademarks of SPARC International, Inc. AMD, Opteron, the AMD logo, and the AMD Opteron logo are trademarks or registered trademarks of Advanced Micro Devices. UNIX is a registered trademark of The Open Group.

This software or hardware and documentation may provide access to or information about content, products, and services from third parties. Oracle Corporation and its affiliates are not responsible for and expressly disclaim all warranties of any kind with respect to third-party content, products, and services unless otherwise set forth in an applicable agreement between you and Oracle. Oracle Corporation and its affiliates will not be responsible for any loss, costs, or damages incurred due to your access to or use of third-party content, products, or services, except as set forth in an applicable agreement between you and Oracle.

# Contents

## Preface

---

Audience	x
Documentation Accessibility	x
Related Documents	x
Conventions	xi

## 1 Overview of System Status Indicators and LEDs

---

1.1 Oracle Database Appliance X7-2S/X7-2M Status Indicators	1-1
1.1.1 Oracle Database Appliance X7-2S/X7-2M Server Status Indicators	1-2
1.1.1.1 Server Front Panel Status Indicators	1-2
1.1.1.2 Server Back Panel Status Indicators	1-4
1.2 Oracle Database Appliance X7-2-HA Status Indicators	1-6
1.2.1 Oracle Database Appliance X7-2-HA Server Node Status Indicators	1-6
1.2.1.1 Server Node Front Panel Status Indicators	1-6
1.2.1.2 Server Node Back Panel Status Indicators	1-9
1.2.2 Oracle Database Appliance X7-2-HA Storage Shelf Indicators	1-10
1.2.2.1 Storage Shelf Front Panel Status Indicators	1-10
1.2.2.2 Storage Shelf Back Panel Status Indicators	1-12
1.3 Oracle Database Appliance X6-2S/X6-2M/X6-2L Status Indicators	1-13
1.3.1 Oracle Database Appliance X6-2S/X6-2M Server Status Indicators	1-14
1.3.1.1 Server Front Panel Status Indicators	1-14
1.3.1.2 Server Back Panel Status Indicators	1-16
1.3.2 Oracle Database Appliance X6-2L Server Status Indicators	1-17
1.3.2.1 Server Front Panel Status Indicators	1-18
1.3.2.2 Server Back Panel Status Indicators	1-20
1.4 Oracle Database Appliance X6-2-HA Status Indicators	1-21
1.4.1 Oracle Database Appliance X6-2-HA Server Node Status Indicators	1-22
1.4.1.1 Server Node Front Panel Status Indicators	1-22
1.4.1.2 Server Node Back Panel Status Indicators	1-24
1.4.2 Oracle Database Appliance X6-2-HA Storage Shelf Indicators	1-26
1.4.2.1 Storage Shelf Front Panel Status Indicators	1-26
1.4.2.2 Storage Shelf Back Panel Status Indicators	1-28

1.5	Oracle Database Appliance X5-2 Status Indicators	1-29
1.5.1	Oracle Database Appliance X5-2 Server Node Status Indicators	1-29
1.5.1.1	Server Node Front Panel Status Indicators	1-30
1.5.1.2	Server Node Back Panel Status Indicators	1-32
1.5.2	Oracle Database Appliance X5-2 Storage Shelf Indicators	1-33
1.5.2.1	Storage Shelf Front Panel Status Indicators	1-33
1.5.2.2	Storage Shelf Back Panel Status Indicators	1-35
1.6	Oracle Database Appliance X3-2/X4-2 Status Indicators	1-36
1.6.1	Oracle Database Appliance X3-2/X4-2 Server Node Status Indicators	1-36
1.6.1.1	Server Node Front Panel Status Indicators	1-36
1.6.1.2	Server Node Back Panel Status Indicators	1-39
1.6.2	Oracle Database Appliance X3-2/X4-2 Storage Shelf Indicators	1-40
1.6.2.1	Storage Shelf Front Panel Status Indicators	1-41
1.6.2.2	Storage Shelf Back Panel Status Indicators	1-42
1.7	Oracle Database Appliance Version 1 Status Indicators	1-43
1.7.1	Server Node Front Status Indicators	1-44
1.7.2	Server Node Fan Status Indicators	1-46
1.7.3	Server Node Storage and Boot Drive Status Indicators	1-47
1.7.4	Server Node Power Supply Status Indicators	1-47
1.7.5	Server Node Rear Status Indicators	1-48
1.7.6	Server Node Internal LEDs	1-50
1.7.7	Server Node Ethernet Port Status Indicators	1-51

## 2 Preparing Oracle Database Appliance for Service

---

2.1	Preparing Oracle Database Appliance X7-2 Series for Service	2-1
2.2	Preparing Oracle Database Appliance X6-2 Series for Service	2-2
2.3	Preparing Oracle Database Appliance X3-2/X4-2/X5-2 for Service	2-3
2.4	Preparing Oracle Database Appliance Version 1 for Service	2-4

## 3 Servicing CRUs That Do Not Require System Power Off

---

3.1	Oracle Database Appliance X7-2 Series Server Node Hot-Pluggable Components	3-1
3.1.1	Servicing NVMe Storage Drives (CRU)	3-2
3.1.1.1	Replacing an NVMe Storage Drive	3-3
3.1.1.2	Adding NVMe Expansion Storage	3-5
3.2	Oracle Database Appliance X6-2 Series Server Node Hot-Pluggable Components	3-6
3.2.1	Servicing NVMe Storage Drives (CRU)	3-8
3.2.1.1	Replacing an NVMe Storage Drive	3-8
3.2.1.2	Adding NVMe Expansion Storage	3-10



3.3	Oracle Database Appliance X3-2/X4-2/X5-2 Series Server Node Hot-Pluggable Components	3-12
3.4	Oracle Database Appliance X3-2/X4-2/X5-2 and X6-2-HA/X7-2-HA Storage Shelf Hot-Pluggable Components	3-13
3.4.1	Servicing Storage Shelf Components	3-14
3.4.1.1	Adding Optional Oracle Database Appliance X7-2-HA Storage Shelf Drives (CRU)	3-15
3.4.1.2	Adding Optional Oracle Database Appliance X6-2-HA Storage Shelf Drives (CRU)	3-19
3.4.1.3	Replace a Storage Shelf HDD or SSD (CRU)	3-21
3.4.1.4	Replace a Storage Shelf Power Supply (CRU)	3-24
3.5	Oracle Database Appliance Version 1 Hot-Pluggable Components	3-31

## 4 Servicing CRUs That Require Server Node Power Off

---

4.1	Servicing Oracle Database Appliance X7-2 Series CRUs	4-1
4.2	Servicing Oracle Database Appliance X6-2 Series CRUs	4-2
4.3	Servicing Oracle Database Appliance X3-2/X4-2/X5-2 CRUs	4-3
4.4	Servicing Oracle Database Appliance Version 1 CRUs	4-5

## 5 Servicing FRUs

---

5.1	Servicing Oracle Database Appliance X7-2 Series FRUs	5-1
5.2	Servicing Oracle Database Appliance X6-2 Series FRUs	5-2
5.2.1	Servicing the Internal SAS Host Bus Adapter (HBA) (FRU)	5-4
5.2.1.1	Replace the Internal SAS HBA Card	5-4
5.2.1.2	Replace the Internal SAS HBA Cables	5-8
5.3	Servicing Oracle Database Appliance X3-2/X4-2/X5-2 FRUs	5-10
5.4	Managing System Faults on Oracle Database Appliance X3-2/X4-2/X5-2, X6-2 Series and X7-2 Series	5-11
5.4.1	Component Fault Management	5-11
5.5	Servicing Oracle Database Appliance Version 1 FRUs	5-12

## 6 Returning Oracle Database Appliance to Operation

---

6.1	Returning Oracle Database Appliance X7-2 Series to Operation	6-1
6.2	Returning Oracle Database Appliance X6-2 Series to Operation	6-2
6.3	Returning Oracle Database Appliance X3-2/X4-2/X5-2 to Operation	6-3
6.4	Powering On an Oracle Database Appliance That Includes a Storage Shelf	6-4
6.5	Returning Oracle Database Appliance Version 1 to Operation	6-5

## 7 Server Node Diagnostic Tools and Resetting the Service Processor

---

7.1	Server Node Diagnostic Tools	7-1
7.2	Resetting the Service Processor	7-3

## 8 Server Node Basic Input/Output System (BIOS)

---

8.1	Oracle Database Appliance X7-2 Series BIOS Utility	8-1
8.1.1	Setting Up BIOS Configuration Parameters	8-2
8.1.2	BIOS Setup Utility Menu Options	8-2
8.2	Oracle Database Appliance X6-2 Series BIOS Utility	8-3
8.2.1	Setting Up BIOS Configuration Parameters	8-3
8.2.2	BIOS Setup Utility Menu Options	8-4
8.3	Oracle Database Appliance X3-2/X4-2/X5-2 BIOS Utility	8-4
8.3.1	Setting Up BIOS Configuration Parameters	8-5
8.3.2	BIOS Setup Utility Menu Options	8-5
8.4	Oracle Database Appliance Version 1 BIOS Utility	8-6

## A Servicing the Oracle Database Appliance Version 1

---

A.1	Preparing Oracle Database Appliance Version 1 for Service	A-1
A.1.1	Component Replacement Policy (CRUs and FRUs)	A-2
A.1.2	Safety Information	A-4
A.1.3	Required Tools	A-4
A.1.4	Obtaining the Chassis Serial Number	A-5
A.1.5	Shutting Down a Server Node and Powering Off the System	A-5
A.1.5.1	Shut Down a Server Node	A-6
A.1.5.2	Power Off the System	A-8
A.1.6	Performing Electrostatic Discharge and Antistatic Prevention Measures	A-8
A.1.7	Removing Server Nodes From the System Chassis	A-9
A.1.7.1	Remove a Server Node From the System Chassis	A-10
A.1.8	Removing the Server Node Top Cover	A-11
A.1.8.1	Remove the Server Node Top Cover	A-12
A.1.9	Removing the Middle Section of the System Top Cover	A-12
A.1.9.1	Remove the Middle Section of System Top Cover	A-13
A.2	Servicing Hot-Pluggable Components	A-14
A.2.1	Servicing Storage Drives and Boot Drives (CRU)	A-15
A.2.1.1	Storage and Boot Drive Locations	A-15
A.2.1.2	Remove a Storage Drive	A-17
A.2.1.3	Install a Storage Drive	A-18
A.2.1.4	Remove a Boot Drive	A-20
A.2.1.5	Install a Boot Drive	A-21

A.2.2	Servicing Fan Modules (CRU)	A-22
A.2.2.1	Detecting a Fan Module Failure	A-23
A.2.2.2	Remove a Fan Module	A-23
A.2.2.3	Install a Fan Module	A-24
A.2.3	Servicing Power Supplies (CRU)	A-25
A.2.3.1	Detecting a Power Supply Failure	A-26
A.2.3.2	Remove a Power Supply	A-26
A.2.3.3	Install a Power Supply	A-27
A.3	Servicing CRUs That Require Server Node Power Off	A-28
A.3.1	Server Node CRU Component Locations	A-29
A.3.2	Servicing Memory Modules (DIMMs) (CRU)	A-30
A.3.2.1	DIMM and CPU Physical Layout	A-31
A.3.2.2	Remove Faulty DIMMs	A-32
A.3.2.3	Install DIMMs	A-35
A.3.2.4	Error Correction and Parity Protection	A-37
A.3.3	Servicing PCIe Risers (CRU)	A-37
A.3.3.1	Remove PCIe Riser From Server Nodes	A-38
A.3.3.2	Install PCIe Riser in Server Nodes	A-40
A.3.4	Servicing PCIe Cards (CRU)	A-41
A.3.4.1	PCIe Card Configuration	A-42
A.3.4.2	Remove PCIe Card From PCIe Riser	A-43
A.3.4.3	Install PCIe Card in PCIe Riser	A-44
A.3.4.4	Remove Primary HBA PCIe Card From Motherboard	A-46
A.3.4.5	Install Primary HBA PCIe Card in Motherboard	A-47
A.3.5	Servicing the Server Node Battery (CRU)	A-49
A.3.5.1	Remove Battery	A-50
A.3.5.2	Install Battery	A-51
A.4	Servicing FRUs	A-51
A.4.1	Removing and Installing the Air Duct (FRU)	A-52
A.4.1.1	Remove Air Duct	A-53
A.4.1.2	Install Air Duct	A-54
A.4.2	Servicing Processors (CPUs) (FRU)	A-55
A.4.2.1	Remove Processor (CPU)	A-56
A.4.2.2	Install Processor (CPU)	A-59
A.4.3	Servicing the Boot Disk Backplane (FRU)	A-61
A.4.3.1	Remove Boot Disk Backplane	A-61
A.4.3.2	Install Boot Disk Backplane	A-62
A.4.4	Servicing the Power Distribution Board (FRU)	A-63
A.4.4.1	Remove Power Distribution Board	A-64
A.4.4.2	Install Power Distribution Board	A-66
A.4.5	Servicing the Disk Midplane Module (FRU)	A-67

A.4.5.1	Remove Disk Midplane Module	A-68
A.4.5.2	Install Disk Midplane Module	A-71
A.4.6	Servicing the Disk Midplane Module HDD Cable (FRU)	A-72
A.4.6.1	Remove Disk Midplane Module HDD Cable	A-73
A.4.6.2	Install Disk Midplane Module HDD Cable	A-74
A.4.7	Servicing the Front Indicator Panels (FRU)	A-74
A.4.7.1	Remove Front Indicator Panel	A-75
A.4.7.2	Install Front Indicator Panel	A-77
A.4.8	Servicing Server Node Cables	A-78
A.4.8.1	Servicing Fan Power Cables (FRU)	A-79
A.4.8.2	Servicing the HBA PCIe Card Cables (FRU)	A-81
A.4.8.3	Servicing the SAS Expander Cable (FRU)	A-85
A.4.8.4	Servicing the Boot Disk Backplane Cables (FRU)	A-87
A.4.9	Servicing the Motherboard Assembly (FRU)	A-90
A.4.9.1	Remove Replaceable Components From Motherboard Assembly	A-92
A.4.9.2	Install Replaceable Components in Motherboard Assembly	A-93
A.5	Returning the Appliance to Operation	A-94
A.5.1	Installing the Server Node Top Cover	A-95
A.5.1.1	Install Server Node Top Cover	A-96
A.5.2	Installing a Server Node Into the System Chassis	A-96
A.5.2.1	Install Server Node Into System Chassis	A-97
A.5.3	Powering On Oracle Database Appliance Version 1	A-98
A.5.3.1	Power On Oracle Database Appliance Version 1	A-99
A.6	Server Node Basic Input/Output System (BIOS)	A-101
A.6.1	BIOS Booting and Setup	A-102
A.6.1.1	Default BIOS Power-On Self-Test (POST) Events	A-102
A.6.1.2	BIOS POST F1 and F2 Errors	A-104
A.6.1.3	How BIOS POST Memory Testing Works	A-106
A.6.2	Clearing Server Node CMOS NVRAM	A-107
A.6.2.1	Reset BIOS Password and Clear CMOS NVRAM Using CLR CMOS Button	A-108
A.6.3	Ethernet Port Naming and Boot Order	A-109
A.6.4	Configuring Support for TPM	A-110
A.6.4.1	Configure TPM Support in BIOS	A-111
A.6.5	Configuring SP LAN Settings	A-115
A.6.5.1	Configure LAN Settings for SP	A-116
A.6.6	Configuring Option ROM Settings in BIOS	A-117
A.6.6.1	Enable or Disable Option ROM Settings	A-117
A.6.7	BIOS Setup Utility Hot Keys	A-118
A.6.8	Accessing the BIOS Setup Utility Menus	A-119
A.6.8.1	Access BIOS Setup Utility Menus	A-120

A.6.9	BIOS Setup Utility Screens	A-122
A.6.9.1	BIOS Setup Utility Screen Overview	A-123
A.6.9.2	BIOS Main Menu Screen	A-124
A.6.9.3	BIOS Advanced Menu Screen	A-125
A.6.9.4	BIOS PCI Menu Screen	A-126
A.6.9.5	BIOS Boot Menu Screen	A-127
A.6.9.6	BIOS Security Menu Screen	A-128
A.6.9.7	BIOS Chipset Menu Screen	A-128
A.6.9.8	BIOS Exit Menu Screen	A-129

## Index

---

# Preface

This guide provides instructions for racking the Oracle Database Appliance Version 1, Oracle Database Appliance X3-2, Oracle Database Appliance X4-2, Oracle Database Appliance X5-2, Oracle Database Appliance X6-2 series, and Oracle Database Appliance X7-2 series.

- [Audience](#) (page x)
- [Documentation Accessibility](#) (page x)
- [Related Documents](#) (page x)
- [Conventions](#) (page xi)

## Audience

This document is intended for technicians, system administrators, and authorized service providers responsible for installing the Oracle Database Appliance.

## Documentation Accessibility

For information about Oracle's commitment to accessibility, visit the Oracle Accessibility Program website at <http://www.oracle.com/pls/topic/lookup?ctx=acc&id=docacc>.

### Access to Oracle Support

Oracle customers that have purchased support have access to electronic support through My Oracle Support. For information, visit <http://www.oracle.com/pls/topic/lookup?ctx=acc&id=info> or visit <http://www.oracle.com/pls/topic/lookup?ctx=acc&id=trs> if you are hearing impaired.

## Related Documents

For more information about Oracle Database Appliance, go to <http://www.oracle.com/goto/oda/docs> and click the appropriate release. The following documents are published in the Oracle Database Appliance online documentation library:

- *Oracle Database Appliance Release Notes*
- *Oracle Database Appliance Licensing Information User Manual*
- *Oracle Database Appliance Security Guide*
- *Oracle Database Appliance Accessibility Guide*
- *Oracle Database Appliance X7-2 Deployment and User's Guide*
- *Oracle Database Appliance X6-2S/X6-2M/X6-2L Deployment and User's Guide*

- *Oracle Database Appliance X6-2-HA Deployment and User's Guide*
- *Oracle Database Appliance Getting Started Guide* (for Oracle Database Appliance X3-2/X4-2/X5-2 and Version 1 models)
- *Oracle Database Appliance Administration and Reference Guide*
- *Oracle Database Appliance Owner's Guide*
- *Oracle Database Appliance Service Manual*

## Conventions

The following text conventions are used in this document:

Convention	Meaning
<b>boldface</b>	Boldface type indicates graphical user interface elements associated with an action or terms defined in the text.
<i>italic</i>	Italic type indicates book titles, emphasis, or placeholder variables for which you supply particular values.
monospace	Monospace type indicates commands within a paragraph, URLs, code in examples, text that appears on the screen, or text that you enter.
# prompt	The pound (#) prompt indicates a command that is run as the root user.

# 1

## Overview of System Status Indicators and LEDs

Learn about Oracle Database Appliance indicators and LEDs.

### Note:

For information about system features and racking, refer to the *Oracle Database Appliance Owner's Guide*. For information about cabling, Oracle ILOM initial setup, and appliance software setup, refer to the appropriate *Deployment and User's Guide* for the Oracle Database Appliance X6 or X7 series or the *Getting Started Guide* for the Oracle Database Appliance X3-2/X4-2/X5-2 or Version 1.

There are several versions of Oracle Database Appliance and this document covers all versions.

- [Oracle Database Appliance X7-2S/X7-2M Status Indicators](#) (page 1-1)  
Learn about Oracle Database Appliance X7-2S/X7-2M status indicators.
- [Oracle Database Appliance X7-2-HA Status Indicators](#) (page 1-6)  
Learn about Oracle Database Appliance X7-2-HA status indicators.
- [Oracle Database Appliance X6-2S/X6-2M/X6-2L Status Indicators](#) (page 1-13)  
Learn about Oracle Database Appliance X6-2S/X6-2M/X6-2L status indicators.
- [Oracle Database Appliance X6-2-HA Status Indicators](#) (page 1-21)  
Learn about Oracle Database Appliance X6-2-HA status indicators.
- [Oracle Database Appliance X5-2 Status Indicators](#) (page 1-29)  
Learn about Oracle Database Appliance X5-2 status indicators.
- [Oracle Database Appliance X3-2/X4-2 Status Indicators](#) (page 1-36)  
Learn about Oracle Database Appliance X3-2/X4-2 status indicators.
- [Oracle Database Appliance Version 1 Status Indicators](#) (page 1-43)  
Learn about Oracle Database Appliance Version 1 front and back status indicators.

### 1.1 Oracle Database Appliance X7-2S/X7-2M Status Indicators

Learn about Oracle Database Appliance X7-2S/X7-2M status indicators.

- [Oracle Database Appliance X7-2S/X7-2M Server Status Indicators](#) (page 1-2)  
See a description of the front and back status indicators for the Oracle Database Appliance X7-2S/X7-2M.



## 1.1.1 Oracle Database Appliance X7-2S/X7-2M Server Status Indicators

See a description of the front and back status indicators for the Oracle Database Appliance X7-2S/X7-2M.

- [Server Front Panel Status Indicators](#) (page 1-2)  
See a listing of the various front panel status indicators for the Oracle Database Appliance X7-2S/X7-2M.
- [Server Back Panel Status Indicators](#) (page 1-4)  
See a listing of the various back panel status indicators for the Oracle Database Appliance X7-2S/X7-2M.

### 1.1.1.1 Server Front Panel Status Indicators

See a listing of the various front panel status indicators for the Oracle Database Appliance X7-2S/X7-2M.

The following figure shows the Oracle Database Appliance X7-2S/X7-2M server front panel includes indicators for the system and storage drives.

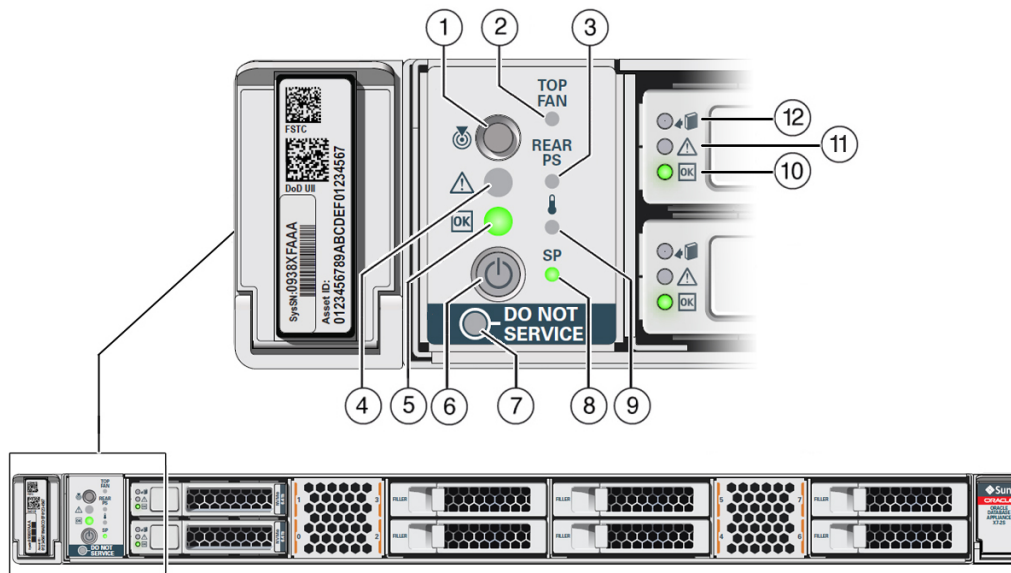

Callout	Indicator/LED: Color	State Meaning
1	Locate: white	<ul style="list-style-type: none"> <li>• Off - Normal operation.</li> <li>• Fast blink - This LED blinks to help locate the system. Operators can turn this indicator on and off remotely using Oracle ILOM.</li> <li>• Pressing this button toggles the fast blink on or off.</li> </ul>

Callout	Indicator/LED: Color	State Meaning
2	Top fan: amber	<p>Indicates that one (or more) of the internal fan modules has failed.</p> <ul style="list-style-type: none"> <li>Off - Indicates steady state; no service is required.</li> <li>On - Indicates service required; service the failed fan module.</li> </ul>
3	Rear PS: amber	<p>Indicates that one (or more) of the power supplies has failed.</p> <ul style="list-style-type: none"> <li>Off - Indicates steady state; no service is required.</li> <li>On - Indicates service required; service the failed power supply.</li> </ul>
4	Service Required: amber	<ul style="list-style-type: none"> <li>Off - Normal operation.</li> <li>On - A fault is present in the server node.</li> </ul> <p>The lighting of this indicator is always accompanied by a system console message that includes a recommended service action.</p>
5	OK: green	<p>Indicates the operational state of the server node:</p> <ul style="list-style-type: none"> <li>On - The server is powered on, and all host POST code checkpoint tests are complete. The server is in one of the following states: 1) the server host is booting the operating system (OS), 2) the server host is running the OS.</li> <li>Off - AC power is not present or the Oracle ILOM boot is not complete.</li> <li>Steady blink - Standby power is on, but the chassis power is off and the Oracle ILOM SP is running.</li> <li>Slow blink - Startup sequence has been initiated on the host. This pattern should begin soon after you power on the server. This status indicates either: (1) POST code checkpoint tests are running on the server host system, or (2) the host is transitioning from the powered-on state to the standby state on shutdown.</li> </ul>
6	Power button	<p>Press to apply full power. Press again to turn main power off, but leave standby power on the Oracle ILOM.</p>

Callout	Indicator/LED: Color	State Meaning
7	DO NOT SERVICE: white	<p>Indicates that the system is not ready to service.</p> <ul style="list-style-type: none"> <li>Off - Normal operation.</li> <li>On - The system is not ready for service.</li> </ul> <p>The DO NOT SERVICE indicator is application specific. This indicator is only illuminated on demand by the Host application.</p>
8	Service processor (SP): green	<ul style="list-style-type: none"> <li>Off - The service processor (SP) is not running.</li> <li>On - The SP is fully operational.</li> <li>Slow blink - SP is booting.</li> </ul>
9	Over temperature warning: amber	<ul style="list-style-type: none"> <li>Off - Normal operation; no service is required.</li> <li>On - The system is experiencing an over temperature warning condition.</li> </ul> <p>This is a warning indication, not a fatal over temperature. Failure to correct this condition might result in the system overheating and shutting down unexpectedly.</p>
10	Drive OK: green	<ul style="list-style-type: none"> <li>Off - Power is off or the installed drive is not recognized by the system.</li> <li>On - The drive is engaged and is receiving power.</li> <li>Random blink - There is disk activity. The indicator blinks on and off to indicate activity.</li> </ul>
11	Drive Service Required: amber	<ul style="list-style-type: none"> <li>Off - The storage drive is operating normally.</li> <li>On - The system has detected a fault with the storage drive.</li> </ul>
12	Drive Ready-to-Remove: blue	<ul style="list-style-type: none"> <li>Off - The storage drive has not been prepared for removal.</li> <li>On - The storage drive can be removed safely during a hot-plug operation.</li> </ul>

### 1.1.1.2 Server Back Panel Status Indicators

See a listing of the various back panel status indicators for the Oracle Database Appliance X7-2S/X7-2M.

The following figure shows the Oracle Database Appliance X7-2S/X7-2M server back panel and includes indicators for the system, power supplies and network ports.

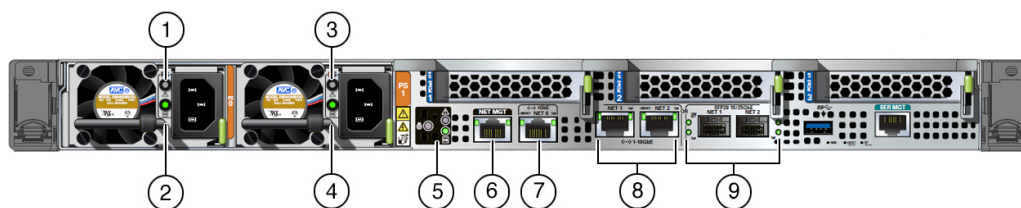

Callout	Indicator/LED: Color	State Meaning
1, 3	PS Service Required: amber	<ul style="list-style-type: none"> <li>Off - Normal operation.</li> <li>On - The power supply (PS) has detected a PS fan failure, PS overtemperature, PS over current, or PS over or under voltage.</li> </ul>
2, 4	PS OK: green	<ul style="list-style-type: none"> <li>Off - No AC power is present.</li> <li>On - Normal operation. Input AC power and DC output voltage are within specification.</li> <li>Slow blink - Normal operation. Input power is within specification. DC output voltage is not enabled.</li> </ul>
5	System locate, service required and OK: various	These operate in the same way as on the front panel.
6	NET MGT port: green	<p>10/100/1000 BASE-T Ethernet management interface.</p> <p>Top left speed indicator:</p> <ul style="list-style-type: none"> <li>On - Green for 1000Base-T link.</li> <li>Off - 10/100BASE-T link.</li> </ul> <p>Top right activity indicator:</p> <ul style="list-style-type: none"> <li>On - Link up.</li> <li>Off - No link or link down.</li> <li>Blinking - Packet activity.</li> </ul>
7	NET 0 port: green	<p>10/100/1000 BASE-T Ethernet interface.</p> <p>Top right speed indicator:</p> <ul style="list-style-type: none"> <li>On - 1000Base-T link.</li> <li>Off - 10/100BASE-T link.</li> </ul> <p>Top left link indicator:</p> <ul style="list-style-type: none"> <li>On - Link up.</li> <li>Off - No link or link down.</li> <li>Blinking - Packet activity.</li> </ul>
8	NET 1 and 2 10 GbE ports: green/amber The 10/25 GbE SFP28 (NET 1 and NET 2) ports are the default network ports for the server. When using an SFP28 port, network connectivity is disabled on the 10GbE RJ-45 ports (NET 1 and NET 2).	<p>10 GbE Ethernet management interface.</p> <p>Top left activity indicator:</p> <ul style="list-style-type: none"> <li>On - Link up.</li> <li>Off - No activity.</li> <li>Flashing - Packet activity.</li> </ul> <p>Top right speed indicator:</p> <ul style="list-style-type: none"> <li>Off - 10/100BASE-T link (if link up).</li> <li>Amber On - 1000BASE-T link.</li> <li>Green On - 10000BASE-T link.</li> </ul>

Callout	Indicator/LED: Color	State Meaning
9	NET 1 and 2 10/25 GbE SFP28 ports: green/amber  The 10/25 GbE SFP28 (NET 1 and NET 2) ports are the default network ports for the server. When using an SFP28 port, network connectivity is disabled on the 10GbE RJ-45 ports (NET 1 and NET 2).	10/25 SFP28 Ethernet management interface.  Top activity indicator: <ul style="list-style-type: none"> <li>• Off - No activity.</li> <li>• Flashing - Packet activity.</li> </ul> Bottom speed indicator: <ul style="list-style-type: none"> <li>• Off - No activity.</li> <li>• Amber On - 10GbE link.</li> <li>• Green On - 25GbE link.</li> </ul>

## 1.2 Oracle Database Appliance X7-2-HA Status Indicators

Learn about Oracle Database Appliance X7-2-HA status indicators.

- [Oracle Database Appliance X7-2-HA Server Node Status Indicators](#) (page 1-6)  
See a description of the Oracle Database Appliance X7-2-HA server node front and back status indicators.
- [Oracle Database Appliance X7-2-HA Storage Shelf Indicators](#) (page 1-10)  
See a description of the front and back Oracle Database Appliance X7-2-HA storage shelf status indicators.

### 1.2.1 Oracle Database Appliance X7-2-HA Server Node Status Indicators

See a description of the Oracle Database Appliance X7-2-HA server node front and back status indicators.

- [Server Node Front Panel Status Indicators](#) (page 1-6)  
See a listing of the various front panel status indicators for the Oracle Database Appliance X7-2-HA server node.
- [Server Node Back Panel Status Indicators](#) (page 1-9)  
See a listing of the various back panel status indicators for the Oracle Database Appliance X7-2-HA server node.

#### 1.2.1.1 Server Node Front Panel Status Indicators

See a listing of the various front panel status indicators for the Oracle Database Appliance X7-2-HA server node.

The following figure shows the Oracle Database Appliance X7-2-HA server node front panel and includes indicators for the system and storage drives.

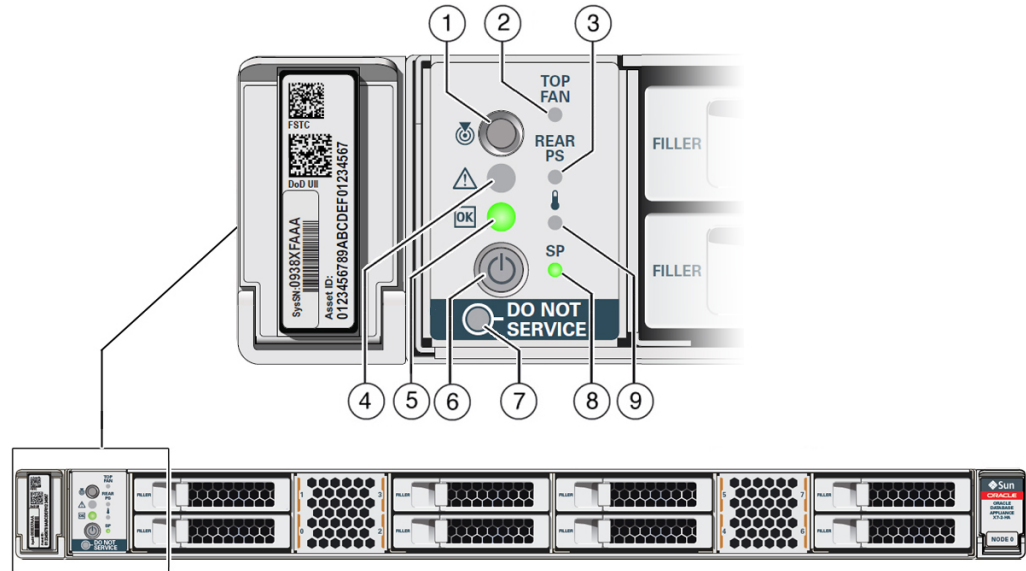

Callout	Indicator/LED: Color	State Meaning
1	Locate: white	<ul style="list-style-type: none"> <li>Off - Normal operation.</li> <li>Fast blink - This LED blinks to help locate the system. Operators can turn this indicator on and off remotely using Oracle ILOM.</li> <li>Pressing this button toggles the fast blink on or off.</li> </ul>
2	Top fan: amber	<p>Indicates that one (or more) of the internal fan modules has failed.</p> <ul style="list-style-type: none"> <li>Off - Indicates steady state; no service is required.</li> <li>On - Indicates service required; service the failed fan module.</li> </ul>
3	Rear PS: amber	<p>Indicates that one (or more) of the power supplies has failed.</p> <ul style="list-style-type: none"> <li>Off - Indicates steady state; no service is required.</li> <li>On - Indicates service required; service the failed power supply.</li> </ul>
4	Service Required: amber	<ul style="list-style-type: none"> <li>Off - Normal operation.</li> <li>On - A fault is present in the server node.</li> </ul> <p>The lighting of this indicator is always accompanied by a system console message that includes a recommended service action.</p>

Callout	Indicator/LED: Color	State Meaning
5	OK: green	<p>Indicates the operational state of the server node:</p> <ul style="list-style-type: none"> <li>On - The server is powered on, and all host POST code checkpoint tests are complete. The server is in one of the following states: 1) the server host is booting the operating system (OS), 2) the server host is running the OS.</li> <li>Off - AC power is not present or the Oracle ILOM boot is not complete.</li> <li>Steady blink - Standby power is on, but the chassis power is off and the Oracle ILOM SP is running.</li> <li>Slow blink - Startup sequence has been initiated on the host. This pattern should begin soon after you power on the server. This status indicates either: (1) POST code checkpoint tests are running on the server host system, or (2) the host is transitioning from the powered-on state to the standby state on shutdown.</li> </ul>
6	Power button	<p>Press to apply full power. Press again to turn main power off, but leave standby power on the Oracle ILOM.</p>
7	DO NOT SERVICE: white	<p>Indicates that the system is not ready to service.</p> <ul style="list-style-type: none"> <li>Off - Normal operation.</li> <li>On - The system is not ready for service.</li> </ul> <p>The DO NOT SERVICE indicator is application specific. This indicator is only illuminated on demand by the Host application.</p>
8	Service processor (SP): green	<ul style="list-style-type: none"> <li>Off - The service processor (SP) is not running.</li> <li>On - The SP is fully operational.</li> <li>Slow blink - SP is booting.</li> </ul>
9	Over temperature warning: amber	<ul style="list-style-type: none"> <li>Off - Normal operation; no service is required.</li> <li>On - The system is experiencing an over temperature warning condition.</li> </ul> <p>This is a warning indication, not a fatal over temperature. Failure to correct this condition might result in the system overheating and shutting down unexpectedly.</p>

## 1.2.1.2 Server Node Back Panel Status Indicators

See a listing of the various back panel status indicators for the Oracle Database Appliance X7-2-HA server node.

The following figure shows the Oracle Database Appliance X7-2-HA server node back panel and includes indicators for the system, power supplies and network ports

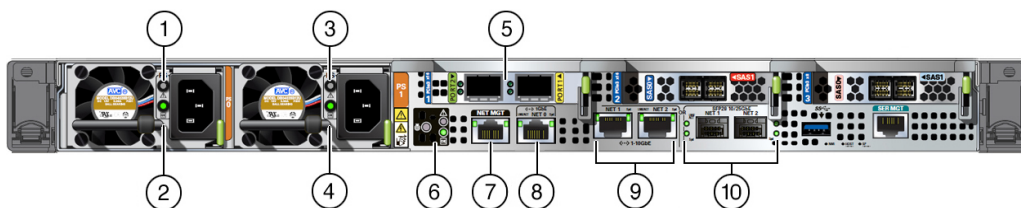

Callout	Indicator/LED: Color	State Meaning
1, 3	PS Service Required: amber	<ul style="list-style-type: none"> <li>Off - Normal operation.</li> <li>On - The power supply (PS) has detected a PS fan failure, PS overtemperature, PS over current, or PS over or under voltage.</li> </ul>
2, 4	PS OK: green	<ul style="list-style-type: none"> <li>Off - No AC power is present.</li> <li>On - Normal operation. Input AC power and DC output voltage are within specification.</li> <li>Slow blink - Normal operation. Input power is within specification. DC output voltage is not enabled.</li> </ul>
5	PORT 1 and 2 private cluster interconnect 10/25 GbE SFP28 ports: green/yellow	<p>10/25 GbE SFP28 interface.</p> <p>Top link indicator:</p> <ul style="list-style-type: none"> <li>Off - No link.</li> <li>Green On - 25GbE link.</li> <li>Yellow On - 10GbE link.</li> </ul> <p>Bottom activity indicator:</p> <ul style="list-style-type: none"> <li>Off - No activity.</li> <li>Flashing - Packet activity.</li> </ul>
6	System locate, service required and OK: various	These operate in the same way as on the front panel.
7	NET MGT port: green	<p>10/100/1000 BASE-T Ethernet management interface.</p> <p>Top left speed indicator:</p> <ul style="list-style-type: none"> <li>On - Green for 1000Base-T link.</li> <li>Off - 10/100BASE-T link.</li> </ul> <p>Top right activity indicator:</p> <ul style="list-style-type: none"> <li>On - Link up.</li> <li>Off - No link or link down.</li> <li>Blinking - Packet activity.</li> </ul>



Callout	Indicator/LED: Color	State Meaning
8	NET 0 port: green	10/100/1000 BASE-T Ethernet interface. Top right speed indicator: <ul style="list-style-type: none"> <li>On - Green for 1000Base-T link.</li> <li>Off - 10/100BASE-T link.</li> </ul> Top left link indicator: <ul style="list-style-type: none"> <li>On - Link up.</li> <li>Off - No link or link down.</li> <li>Blinking - Packet activity.</li> </ul>
9	NET 1 and 2 10 GbE ports: green/amber The 10/25 GbE SFP28 (NET 1 and NET 2) ports are the default network ports for the server. When using an SFP28 port, network connectivity is disabled on the 10GbE RJ-45 ports (NET 1 and NET 2).	10 GbE Ethernet management interface. Top left activity indicator: <ul style="list-style-type: none"> <li>On - Link up.</li> <li>Off - No activity.</li> <li>Flashing - Packet activity.</li> </ul> Top right speed indicator: <ul style="list-style-type: none"> <li>Off - 10/100BASE-T link (if link up).</li> <li>Amber On - 1000BASE-T link.</li> <li>Green On - 10000BASE-T link.</li> </ul>
10	NET 1 and 2 10/25 GbE SFP28 ports: green/amber The 10/25 GbE SFP28 (NET 1 and NET 2) ports are the default network ports for the server. When using an SFP28 port, network connectivity is disabled on the 10GbE RJ-45 ports (NET 1 and NET 2).	10/25 GbE SFP28 interface. Top activity indicator: <ul style="list-style-type: none"> <li>Off - No activity.</li> <li>Flashing - Packet activity.</li> </ul> Bottom speed indicator: <ul style="list-style-type: none"> <li>Off - No activity.</li> <li>Amber On - 10GbE link.</li> <li>Green On - 25GbE link.</li> </ul>

## 1.2.2 Oracle Database Appliance X7-2-HA Storage Shelf Indicators

See a description of the front and back Oracle Database Appliance X7-2-HA storage shelf status indicators.

- [Storage Shelf Front Panel Status Indicators](#) (page 1-10)  
See a listing of the various front panel status indicators for the Oracle Database Appliance X7-2-HA storage shelf.
- [Storage Shelf Back Panel Status Indicators](#) (page 1-12)  
See a listing of the various back panel status indicators for the Oracle Database Appliance X7-2-HA storage shelf.

### 1.2.2.1 Storage Shelf Front Panel Status Indicators

See a listing of the various front panel status indicators for the Oracle Database Appliance X7-2-HA storage shelf.

The following figure shows the controls and indicators on the for the Oracle Database Appliance X7-2-HA storage shelf (DE3-24C) front panel and drives.

**Note:**

The 2 or 3 character LED enclosure ID display panel on the front of the storage shelf is not used with the Oracle Database Appliance product. Any numbers or letters displayed in this panel other than zeros could indicate a fault with either the panel, its cabling (neither of which are customer replaceable), or some other storage shelf component.

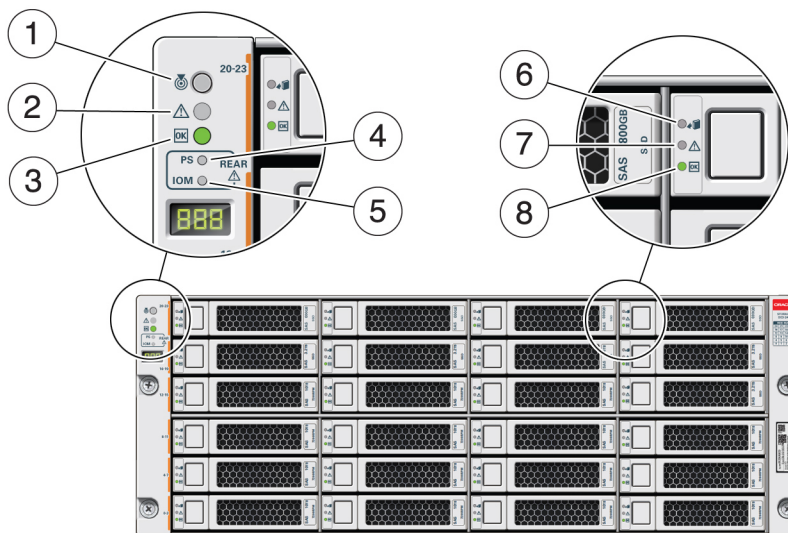

Callout	Indicator/LED: Color	State Meaning
1	Locate: white	<ul style="list-style-type: none"> <li>Off - Normal operation.</li> <li>Fast blink - This LED blinks to help locate the system. Operators can turn this indicator on and off remotely using Oracle ILOM.</li> <li>Pressing this button toggles the fast blink on or off.</li> </ul>
2	Service Required: amber	<ul style="list-style-type: none"> <li>Off - Normal operation.</li> <li>Steady on - A fault is present in the storage shelf.</li> </ul>
3	OK: green	<ul style="list-style-type: none"> <li>On - The storage shelf is powered on and operating normally.</li> <li>Off - The storage shelf is unplugged or turned off.</li> </ul>
4	Power Supply fault indicator: amber	<ul style="list-style-type: none"> <li>On - Indicates a fault with a power supply. View the LEDs at the back of the storage shelf to determine which power supply has the fault.</li> <li>Off - Normal operation.</li> </ul>

Callout	Indicator/LED: Color	State Meaning
5	SAS I/O Module fault indicator: amber	<ul style="list-style-type: none"> <li>On - Indicates a fault with a SAS I/O module. View the LEDs at the back of the storage shelf to determine which module has the fault.</li> <li>Off - Normal operation.</li> </ul>
6	Ready-to-Remove: blue	<ul style="list-style-type: none"> <li>On - The storage drive can be safely removed during a hot-plug operation.</li> <li>Off - The storage drive has not been prepared for removal.</li> </ul>
7	Drive Service Required: amber	<ul style="list-style-type: none"> <li>Off - Normal operation.</li> <li>Steady on - A fault is present in the disk drive.</li> </ul>
8	Power/Activity: green	<ul style="list-style-type: none"> <li>On - The drive is installed and recognized by the system but there is no drive activity.</li> <li>Blink - The LED blinks randomly in response to data being written to or read from the drive.</li> <li>Off - The drive is powered off or the installed drive is not recognized by the system.</li> </ul>

### 1.2.2.2 Storage Shelf Back Panel Status Indicators

See a listing of the various back panel status indicators for the Oracle Database Appliance X7-2-HA storage shelf.

The following figure shows the controls and indicators on the Oracle Database Appliance X7-2-HA storage shelf (DE3-24C) back panel.

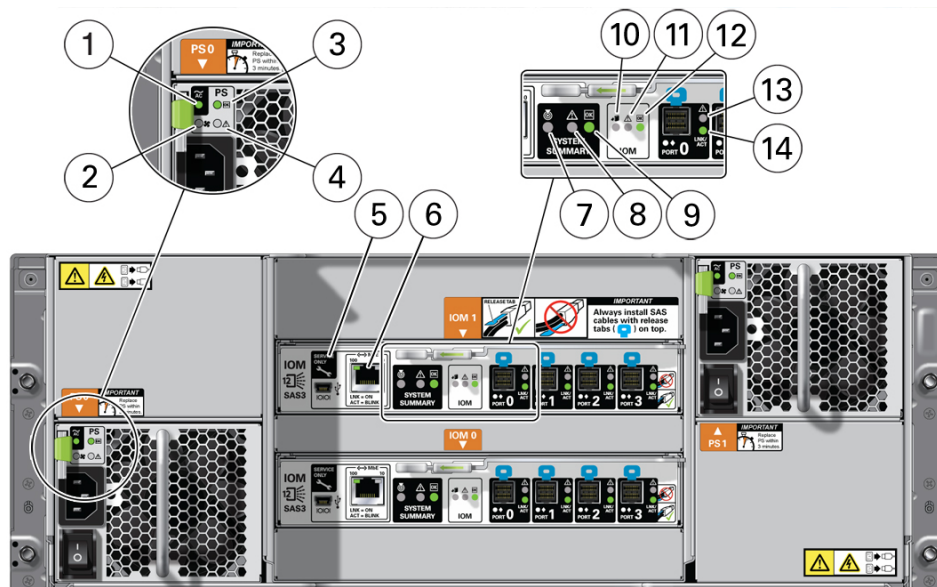

Callout	Indicator/LED: Color	State Meaning
1	AC power fault indicator: amber	<ul style="list-style-type: none"> <li>On - Indicates an AC power fault.</li> <li>Off - Normal operation.</li> </ul>
2	Fan fail indicator: amber	<ul style="list-style-type: none"> <li>On - The fan is faulty.</li> <li>Off - Normal operation.</li> </ul>
3	Power supply status indicator: green	<ul style="list-style-type: none"> <li>On - The power supply is operating normally.</li> <li>Off - The power supply is unplugged or turned off.</li> </ul>
4	DC power fail indicator: amber	<ul style="list-style-type: none"> <li>On - The power supply is faulty.</li> <li>Off - Normal operation.</li> </ul>
5	Reserved	This port is reserved for Oracle Service.
6	Network port (reserved)	This port is reserved for Oracle Service.
7	Locate: white	<ul style="list-style-type: none"> <li>Off - Normal operation.</li> <li>Fast blink - This LED blinks to help locate the system. Operators can turn this indicator on and off remotely using Oracle ILOM.</li> <li>Pressing this button toggles the fast blink on or off.</li> </ul>
8	Service Required: amber	<ul style="list-style-type: none"> <li>Off - Normal operation.</li> <li>Steady on - A fault is present in the storage shelf.</li> </ul>
9	OK: green	<ul style="list-style-type: none"> <li>On - The storage shelf is powered on and operating normally.</li> <li>Off - The storage shelf is unplugged or turned off.</li> </ul>
10	SAS I/O Module Ready-to-Remove: blue	<ul style="list-style-type: none"> <li>On - The I/O module can be safely removed during a hot-plug operation.</li> <li>Off - The I/O module has not been prepared for removal.</li> </ul>
11	SAS I/O Module Service Required indicator: amber	<ul style="list-style-type: none"> <li>Off - Normal operation.</li> <li>Steady on - A fault is present in the SAS I/O module.</li> </ul>
12	SAS I/O Module OK: green	<ul style="list-style-type: none"> <li>On - The I/O module is powered on and operating normally.</li> <li>Off - The I/O module is unplugged or turned off.</li> </ul>
13	Host SAS port Service Required indicator: amber	<ul style="list-style-type: none"> <li>Off - Normal operation.</li> <li>Steady on - A fault is present with the port or connection.</li> </ul>
14	Host SAS port activity indicator: green	<ul style="list-style-type: none"> <li>Random blinking - Indicates host SAS link activity.</li> <li>Off - No link activity.</li> </ul>

## 1.3 Oracle Database Appliance X6-2S/X6-2M/X6-2L Status Indicators

Learn about Oracle Database Appliance X6-2S/X6-2M/X6-2L status indicators.

- [Oracle Database Appliance X6-2S/X6-2M Server Status Indicators](#) (page 1-14)  
See a description of the front and back status indicators for the Oracle Database Appliance X6-2S/X6-2M.
- [Oracle Database Appliance X6-2L Server Status Indicators](#) (page 1-17)  
See a description of the front and back status indicators for the Oracle Database Appliance X6-2L.

## 1.3.1 Oracle Database Appliance X6-2S/X6-2M Server Status Indicators

See a description of the front and back status indicators for the Oracle Database Appliance X6-2S/X6-2M.

- [Server Front Panel Status Indicators](#) (page 1-14)  
See a listing of the various front panel status indicators for the Oracle Database Appliance X6-2S/X6-2M.
- [Server Back Panel Status Indicators](#) (page 1-16)  
See a listing of the various back panel status indicators for the Oracle Database Appliance X6-2S/X6-2M.

### 1.3.1.1 Server Front Panel Status Indicators

See a listing of the various front panel status indicators for the Oracle Database Appliance X6-2S/X6-2M.

The following figure shows the Oracle Database Appliance X6-2S/X6-2M server front panel and includes indicators for the system and storage drives.

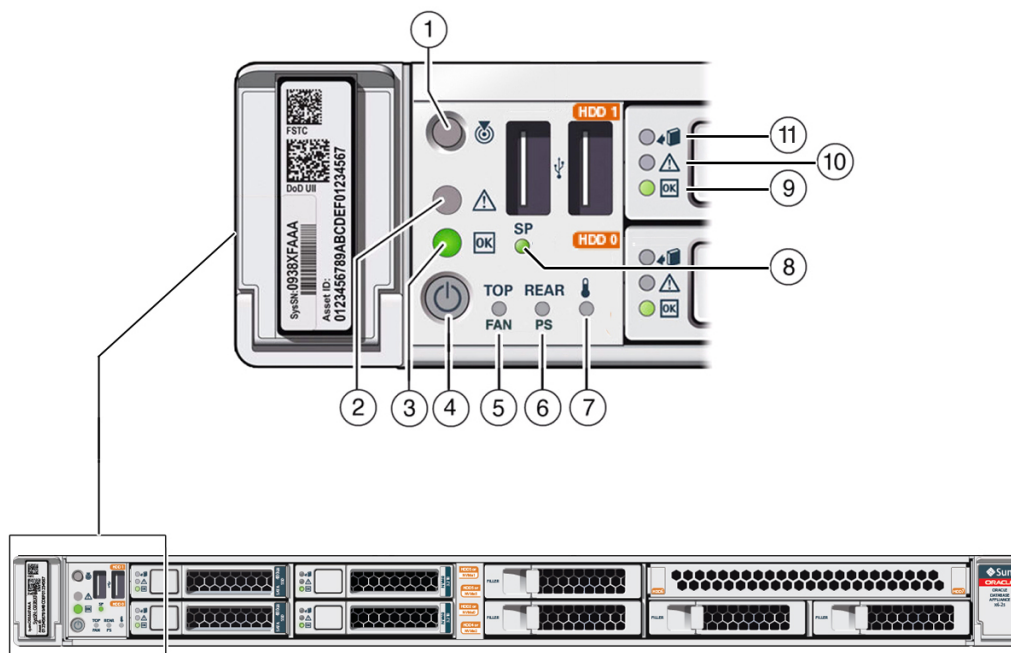

Callout	Indicator/LED: Color	State Meaning
1	Locate: white	<ul style="list-style-type: none"> <li>Off - Normal operation.</li> <li>Fast blink - This LED blinks to help locate the system. Operators can turn this indicator on and off remotely using Oracle ILOM.</li> <li>Pressing this button toggles the fast blink on or off.</li> </ul>
2	Service Required: amber	<ul style="list-style-type: none"> <li>Off - Normal operation.</li> <li>On - A fault is present in the server node.</li> </ul> <p>The lighting of this indicator is always accompanied by a system console message that includes a recommended service action.</p>
3	OK: green	<p>Indicates the operational state of the server node:</p> <ul style="list-style-type: none"> <li>On - The server is powered on, and all host POST code checkpoint tests are complete. The server is in one of the following states: 1) the server host is booting the operating system (OS), 2) the server host is running the OS.</li> <li>Off - AC power is not present or the Oracle ILOM boot is not complete.</li> <li>Steady blink - Standby power is on, but the chassis power is off and the Oracle ILOM SP is running.</li> <li>Slow blink - Startup sequence has been initiated on the host. This pattern should begin soon after you power on the server. This status indicates either: (1) POST code checkpoint tests are running on the server host system, or (2) the host is transitioning from the powered-on state to the standby state on shutdown.</li> </ul>
4	Power button	Press to apply full power. Press again to turn main power off, but leave standby power on the Oracle ILOM.
5	Top fan: amber	<p>Indicates that one (or more) of the internal fan modules has failed.</p> <ul style="list-style-type: none"> <li>Off - Indicates steady state; no service is required.</li> <li>On - Indicates service required; service the failed fan module.</li> </ul>
6	Rear PS: amber	<p>Indicates that one (or more) of the power supplies has failed.</p> <ul style="list-style-type: none"> <li>Off - Indicates steady state; no service is required.</li> <li>On - Indicates service required; service the failed power supply.</li> </ul>

Callout	Indicator/LED: Color	State Meaning
7	Over temperature warning: amber	<ul style="list-style-type: none"> <li>Off - Normal operation; no service is required.</li> <li>On - The system is experiencing an over temperature warning condition.</li> </ul> <p>This is a warning indication, not a fatal over temperature. Failure to correct this condition might result in the system overheating and shutting down unexpectedly.</p>
8	Service processor (SP): green	<ul style="list-style-type: none"> <li>Off - The service processor (SP) is not running.</li> <li>On - The SP is fully operational.</li> <li>Slow blink - SP is booting.</li> </ul>
9	Drive OK: green	<ul style="list-style-type: none"> <li>Off - Power is off or the installed drive is not recognized by the system.</li> <li>On - The drive is engaged and is receiving power.</li> <li>Random blink - There is disk activity. The indicator blinks on and off to indicate activity.</li> </ul>
10	Drive Service Required: amber	<ul style="list-style-type: none"> <li>Off - The storage drive is operating normally.</li> <li>On - The system has detected a fault with the storage drive.</li> </ul>
11	Drive Ready-to-Remove: blue	<ul style="list-style-type: none"> <li>Off - The storage drive has not been prepared for removal.</li> <li>On - The storage drive can be removed safely during a hot-plug operation.</li> </ul>

### 1.3.1.2 Server Back Panel Status Indicators

See a listing of the various back panel status indicators for the Oracle Database Appliance X6-2S/X6-2M.

The following figure shows the Oracle Database Appliance X6-2S/X6-2M server back panel and includes indicators for the system, power supplies and network ports.

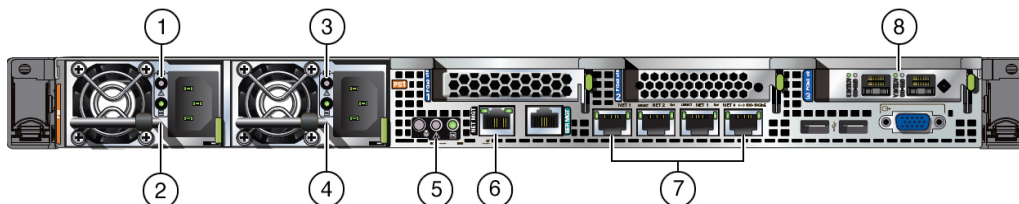

Callout	Indicator/LED: Color	State Meaning
1, 3	PS Service Required: amber	<ul style="list-style-type: none"> <li>Off - Normal operation.</li> <li>On - The power supply (PS) has detected a PS fan failure, PS overtemperature, PS over current, or PS over or under voltage.</li> </ul>
2, 4	PS OK: green	<ul style="list-style-type: none"> <li>Off - No AC power is present.</li> <li>On - Normal operation. Input AC power and DC output voltage are within specification.</li> <li>Slow blink - Normal operation. Input power is within specification. DC output voltage is not enabled.</li> </ul>
5	System locate, service required and OK: various	These operate in the same way as on the front panel.
6	NET MGT port: green	10/100/1000 BASE-T Ethernet management interface. Top left link indicator: <ul style="list-style-type: none"> <li>On - Green for 1000Base-T link.</li> <li>Off - 10/100BASE-T link.</li> </ul> Top right activity indicator: <ul style="list-style-type: none"> <li>On - Link up.</li> <li>Off - No link or link down.</li> <li>Blinking - Packet activity.</li> </ul>
7	NET 0-3 ports: green/amber	100/1000/10000 BASE-T Ethernet management interface. Top left activity indicator: <ul style="list-style-type: none"> <li>On - No function.</li> <li>Off - No activity.</li> <li>Blinking - Packet activity.</li> </ul> Top right link indicator: <ul style="list-style-type: none"> <li>On - Amber for 1000Base-T link; green for 10GBBase-T link.</li> <li>Off - 100BASE-T link.</li> <li>Blinking - No function.</li> </ul>
8	Dual 10 GbE SFP+ PCIe 2.0 Low Profile Adapter ports: green/amber	1000/10000 BASE-T Ethernet management interface. GRN=10G: <ul style="list-style-type: none"> <li>On - Green for 10GbE link; amber for 1GbE link.</li> <li>Off - No function.</li> </ul> ACT/LINK (A or B): <ul style="list-style-type: none"> <li>On - Green for link up.</li> <li>Off - No link.</li> <li>Blinking - Green for packet activity.</li> </ul>

## 1.3.2 Oracle Database Appliance X6-2L Server Status Indicators

See a description of the front and back status indicators for the Oracle Database Appliance X6-2L.



- [Server Front Panel Status Indicators](#) (page 1-18)  
See a listing of the various front panel status indicators for the Oracle Database Appliance X6-2L.
- [Server Back Panel Status Indicators](#) (page 1-20)  
See a listing of the various back panel status indicators for the Oracle Database Appliance X6-2L.

### 1.3.2.1 Server Front Panel Status Indicators

See a listing of the various front panel status indicators for the Oracle Database Appliance X6-2L.

The following figure shows the Oracle Database Appliance X6-2L server front panel and includes indicators for the system and storage drives.

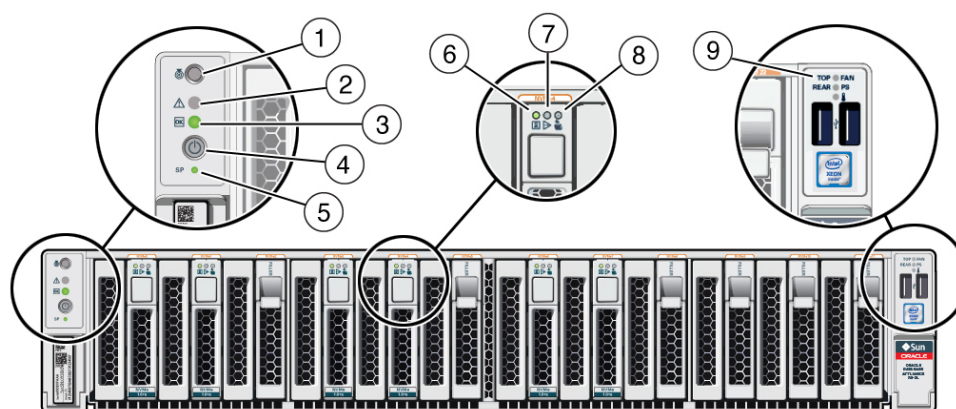

Callout	Indicator/LED: Color	State Meaning
1	Locate: white	<ul style="list-style-type: none"> <li>• Off - Normal operation.</li> <li>• Fast blink - This LED blinks to help locate the system. Operators can turn this indicator on and off remotely using Oracle ILOM.</li> <li>• Pressing this button toggles the fast blink on or off.</li> </ul>
2	Service Required: amber	<ul style="list-style-type: none"> <li>• Off - Normal operation.</li> <li>• On - A fault is present in the server node.</li> </ul> <p>The lighting of this indicator is always accompanied by a system console message that includes a recommended service action.</p>

Callout	Indicator/LED: Color	State Meaning
3	OK: green	<p>Indicates the operational state of the server node:</p> <ul style="list-style-type: none"> <li>On - The server is powered on, and all host POST code checkpoint tests are complete. The server is in one of the following states: 1) the server host is booting the operating system (OS), 2) the server host is running the OS.</li> <li>Off - AC power is not present or the Oracle ILOM boot is not complete.</li> <li>Steady blink - Standby power is on, but the chassis power is off and the Oracle ILOM SP is running.</li> <li>Slow blink - Startup sequence has been initiated on the host. This pattern should begin soon after you power on the server. This status indicates either: (1) POST code checkpoint tests are running on the server host system, or (2) the host is transitioning from the powered-on state to the standby state on shutdown.</li> </ul>
4	Power button	<p>Press to apply full power. Press again to turn main power off, but leave standby power on the Oracle ILOM.</p>
5	Service processor (SP): green	<ul style="list-style-type: none"> <li>Off - The service processor (SP) is not running.</li> <li>On - The SP is fully operational.</li> <li>Slow blink - SP is booting.</li> </ul>
6	Drive OK: green	<ul style="list-style-type: none"> <li>Off - Power is off or the installed drive is not recognized by the system.</li> <li>On - The drive is engaged and is receiving power.</li> <li>Random blink - There is disk activity. The indicator blinks on and off to indicate activity.</li> </ul>
7	Drive Service Required: amber	<ul style="list-style-type: none"> <li>Off - The storage drive is operating normally.</li> <li>On - The system has detected a fault with the storage drive.</li> </ul>
8	Drive Ready-to-Remove: blue	<ul style="list-style-type: none"> <li>Off - The storage drive has not been prepared for removal.</li> <li>On - The storage drive can be removed safely during a hot-plug operation.</li> </ul>

Callout	Indicator/LED: Color	State Meaning
9	Top fan: amber Rear PS: amber Over-temperature warning: amber	<p>Top fan:</p> <ul style="list-style-type: none"> <li>Off - Indicates steady state; no service is required.</li> <li>On - Indicates service required; service the failed fan module.</li> </ul> <p>Rear PS:</p> <ul style="list-style-type: none"> <li>Off - Indicates steady state; no service is required.</li> <li>On - Indicates service required; service the failed power supply.</li> </ul> <p>Over-temperature warning:</p> <ul style="list-style-type: none"> <li>Off - Normal operation; no service is required.</li> <li>On - The system is experiencing an over-temperature warning condition. This is a warning indication, not a fatal over-temperature. Failure to correct this condition might result in the system overheating and shutting down unexpectedly.</li> </ul>

### 1.3.2.2 Server Back Panel Status Indicators

See a listing of the various back panel status indicators for the Oracle Database Appliance X6-2L.

The following figure shows the Oracle Database Appliance X6-2S/X6-2M server back panel and includes indicators for the system, power supplies and network ports.

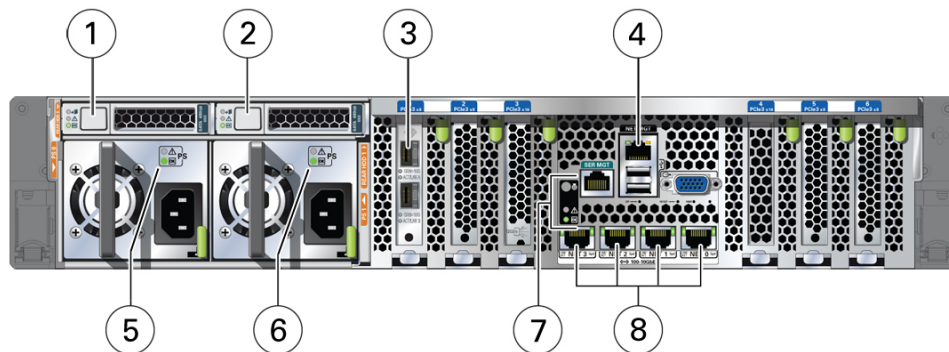

Callout	Indicator/LED: Color	State Meaning
1, 2	Storage drive status: various	These operate in the same way as on the front panel.

Callout	Indicator/LED: Color	State Meaning
3	Dual-port 10 GbE SFP+ PCIe 2.0 Low Profile Adapter ports: green/amber	<p>GRN=10G:</p> <ul style="list-style-type: none"> <li>On - Green for 10GbE link; amber for 1GbE link.</li> <li>Off - No function.</li> </ul> <p>ACT/LINK (A or B):</p> <ul style="list-style-type: none"> <li>On - Green for link up.</li> <li>Off - No link.</li> <li>Blinking - Green for packet activity.</li> </ul>
4	NET MGT port: green	<p>10/100/1000 BASE-T Ethernet management interface.</p> <p>Top left link indicator:</p> <ul style="list-style-type: none"> <li>On - Green for 1000Base-T link.</li> <li>Off - 10/100BASE-T link.</li> </ul> <p>Top right activity indicator:</p> <ul style="list-style-type: none"> <li>On - Link up.</li> <li>Off - No link or link down.</li> <li>Blinking - Packet activity.</li> </ul>
5, 6	PS Service Required: amber PS OK: green	<p>PS Service Required:</p> <ul style="list-style-type: none"> <li>Off - Normal operation.</li> <li>On - The power supply (PS) has detected a PS fan failure, PS over-temperature, PS over current, or PS over or under voltage.</li> </ul> <p>PS OK:</p> <ul style="list-style-type: none"> <li>Off - No AC power is present.</li> <li>On - Normal operation. Input AC power and DC output voltage are within specification.</li> <li>Slow blink - Normal operation. Input power is within specification. DC output voltage is not enabled.</li> </ul>
7	System locate, service required and OK: various	These operate in the same way as on the front panel.
8	NET 0-3 ports: green/amber	<p>100/1000/10000 BASE-T Ethernet management interface.</p> <p>Top left activity indicator:</p> <ul style="list-style-type: none"> <li>On - No function.</li> <li>Off - No activity.</li> <li>Blinking - Packet activity.</li> </ul> <p>Top right link indicator:</p> <ul style="list-style-type: none"> <li>On - Amber for 1000Base-T link; green for 10GBBase-T link.</li> <li>Off - 100BASE-T link.</li> <li>Blinking - No function.</li> </ul>

## 1.4 Oracle Database Appliance X6-2-HA Status Indicators

Learn about Oracle Database Appliance X6-2-HA status indicators.

- [Oracle Database Appliance X6-2-HA Server Node Status Indicators](#) (page 1-22)  
See a description of the Oracle Database Appliance X6-2-HA server node front and back status indicators.
- [Oracle Database Appliance X6-2-HA Storage Shelf Indicators](#) (page 1-26)  
See a description of the front and back Oracle Database Appliance X6-2-HA storage shelf status indicators.

## 1.4.1 Oracle Database Appliance X6-2-HA Server Node Status Indicators

See a description of the Oracle Database Appliance X6-2-HA server node front and back status indicators.

- [Server Node Front Panel Status Indicators](#) (page 1-22)  
See a listing of the various front panel status indicators for the Oracle Database Appliance X6-2-HA server node.
- [Server Node Back Panel Status Indicators](#) (page 1-24)  
See a listing of the various back panel status indicators for the Oracle Database Appliance X6-2-HA server node.

### 1.4.1.1 Server Node Front Panel Status Indicators

See a listing of the various front panel status indicators for the Oracle Database Appliance X6-2-HA server node.

The following figure shows the Oracle Database Appliance X6-2-HA server node front panel and includes indicators for the system and storage drives.

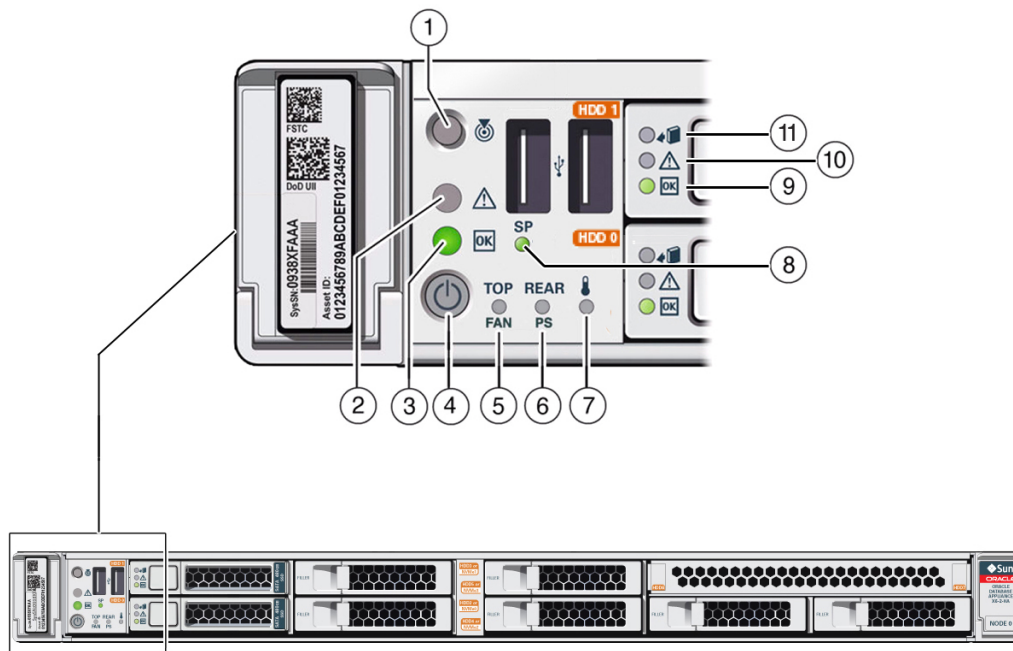

Callout	Indicator/LED: Color	State Meaning
1	Locate: white	<ul style="list-style-type: none"> <li>Off - Normal operation.</li> <li>Fast blink - This LED blinks to help locate the system. Operators can turn this indicator on and off remotely using Oracle ILOM.</li> <li>Pressing this button toggles the fast blink on or off.</li> </ul>
2	Service Required: amber	<ul style="list-style-type: none"> <li>Off - Normal operation.</li> <li>On - A fault is present in the server node.</li> </ul> <p>The lighting of this indicator is always accompanied by a system console message that includes a recommended service action.</p>
3	OK: green	<p>Indicates the operational state of the server node:</p> <ul style="list-style-type: none"> <li>On - The server is powered on, and all host POST code checkpoint tests are complete. The server is in one of the following states: 1) the server host is booting the operating system (OS), 2) the server host is running the OS.</li> <li>Off - AC power is not present or the Oracle ILOM boot is not complete.</li> <li>Steady blink - Standby power is on, but the chassis power is off and the Oracle ILOM SP is running.</li> <li>Slow blink - Startup sequence has been initiated on the host. This pattern should begin soon after you power on the server. This status indicates either: (1) POST code checkpoint tests are running on the server host system, or (2) the host is transitioning from the powered-on state to the standby state on shutdown.</li> </ul>
4	Power button	Press to apply full power. Press again to turn main power off, but leave standby power on the Oracle ILOM.
5	Top fan: amber	<p>Indicates that one (or more) of the internal fan modules has failed.</p> <ul style="list-style-type: none"> <li>Off - Indicates steady state; no service is required.</li> <li>On - Indicates service required; service the failed fan module.</li> </ul>
6	Rear PS: amber	<p>Indicates that one (or more) of the power supplies has failed.</p> <ul style="list-style-type: none"> <li>Off - Indicates steady state; no service is required.</li> <li>On - Indicates service required; service the failed power supply.</li> </ul>

Callout	Indicator/LED: Color	State Meaning
7	Over temperature warning: amber	<ul style="list-style-type: none"> <li>Off - Normal operation; no service is required.</li> <li>On - The system is experiencing an over temperature warning condition.</li> </ul> <p>This is a warning indication, not a fatal over temperature. Failure to correct this condition might result in the system overheating and shutting down unexpectedly.</p>
8	Service processor (SP): green	<ul style="list-style-type: none"> <li>Off - The service processor (SP) is not running.</li> <li>On - The SP is fully operational.</li> <li>Slow blink - SP is booting.</li> </ul>
9	Drive OK: green	<ul style="list-style-type: none"> <li>Off - Power is off or the installed drive is not recognized by the system.</li> <li>On - The drive is engaged and is receiving power.</li> <li>Random blink - There is disk activity. The indicator blinks on and off to indicate activity.</li> </ul>
10	Drive Service Required: amber	<ul style="list-style-type: none"> <li>Off - The storage drive is operating normally.</li> <li>On - The system has detected a fault with the storage drive.</li> </ul>
11	Drive Ready-to-Remove: blue	<ul style="list-style-type: none"> <li>Off - The storage drive has not been prepared for removal.</li> <li>On - The storage drive can be removed safely during a hot-plug operation.</li> </ul>

### 1.4.1.2 Server Node Back Panel Status Indicators

See a listing of the various back panel status indicators for the Oracle Database Appliance X6-2-HA server node.

The following figure shows the Oracle Database Appliance X6-2-HA server node back panel and includes indicators for the system, power supplies and network ports

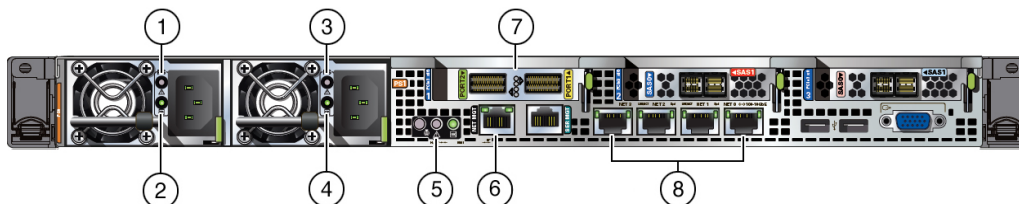

Callout	Indicator/LED: Color	State Meaning
1, 3	PS Service Required: amber	<ul style="list-style-type: none"> <li>Off - Normal operation.</li> <li>On - The power supply (PS) has detected a PS fan failure, PS overtemperature, PS over current, or PS over or under voltage.</li> </ul>
2, 4	PS OK: green	<ul style="list-style-type: none"> <li>Off - No AC power is present.</li> <li>On - Normal operation. Input AC power and DC output voltage are within specification.</li> <li>Slow blink - Normal operation. Input power is within specification. DC output voltage is not enabled.</li> </ul>
5	System locate, service required and OK: various	These operate in the same way as on the front panel.
6	NET MGT port: green	<p>10/100/1000 BASE-T Ethernet management interface.</p> <p>Top left link indicator:</p> <ul style="list-style-type: none"> <li>On - Green for 1000Base-T link.</li> <li>Off - 10/100BASE-T link.</li> </ul> <p>Top right activity indicator:</p> <ul style="list-style-type: none"> <li>On - Link up.</li> <li>Off - No link or link down.</li> <li>Blinking - Packet activity.</li> </ul>
7	<p>Two InfiniBand QSFP+ Adapter ports (shown): green/yellow</p> <p>--or--</p> <p>Dual 10 GbE SFP+ PCIe 2.0 Low Profile Adapter ports (not shown): green/amber</p>	<p><b>InfiniBand QSFP+ interface.</b></p> <ul style="list-style-type: none"> <li>Green on - InfiniBand physical link established.</li> <li>Green off - No link.</li> <li>Yellow on - InfiniBand is discovered over the link, but no data is being passed .</li> <li>Yellow off - A physical and/or logical link has not been established.</li> <li>Yellow blinking - Data being passed.</li> </ul> <p><b>Dual 10 GbE SFP+ interface.</b></p> <ul style="list-style-type: none"> <li>GRN=10G: <ul style="list-style-type: none"> <li>On - Green for 10GbE link; amber for 1GbE link.</li> <li>Off - No function.</li> </ul> </li> <li>ACT/LINK (A or B): <ul style="list-style-type: none"> <li>On - Green for link up.</li> <li>Off - No link.</li> <li>Blinking - Green for packet activity.</li> </ul> </li> </ul>



Callout	Indicator/LED: Color	State Meaning
8	NET 0-3 ports: green/amber	<p>100/1000/10000 BASE-T Ethernet management interface.</p> <p>Top left activity indicator:</p> <ul style="list-style-type: none"> <li>• On - No function.</li> <li>• Off - No activity.</li> <li>• Blinking - Packet activity.</li> </ul> <p>Top right link indicator:</p> <ul style="list-style-type: none"> <li>• On - Amber for 1000Base-T link; green for 10GBBase-T link.</li> <li>• Off - 100BASE-T link.</li> <li>• Blinking - No function.</li> </ul>

## 1.4.2 Oracle Database Appliance X6-2-HA Storage Shelf Indicators

See a description of the front and back Oracle Database Appliance X6-2-HA storage shelf status indicators.

- [Storage Shelf Front Panel Status Indicators](#) (page 1-26)  
See a listing of the various front panel status indicators for the Oracle Database Appliance X6-2-HA storage shelf.
- [Storage Shelf Back Panel Status Indicators](#) (page 1-28)  
See a listing of the various back panel status indicators for the Oracle Database Appliance X6-2-HA storage shelf.

### 1.4.2.1 Storage Shelf Front Panel Status Indicators

See a listing of the various front panel status indicators for the Oracle Database Appliance X6-2-HA storage shelf.

The following figure shows the controls and indicators on the for the Oracle Database Appliance X6-2-HA storage shelf (DE3-24C) front panel and drives.

 **Note:**

The 2 or 3 character LED enclosure ID display panel on the front of the storage shelf is not used with the Oracle Database Appliance product. Any numbers or letters displayed in this panel other than zeros could indicate a fault with either the panel, its cabling (neither of which are customer replaceable), or some other storage shelf component.

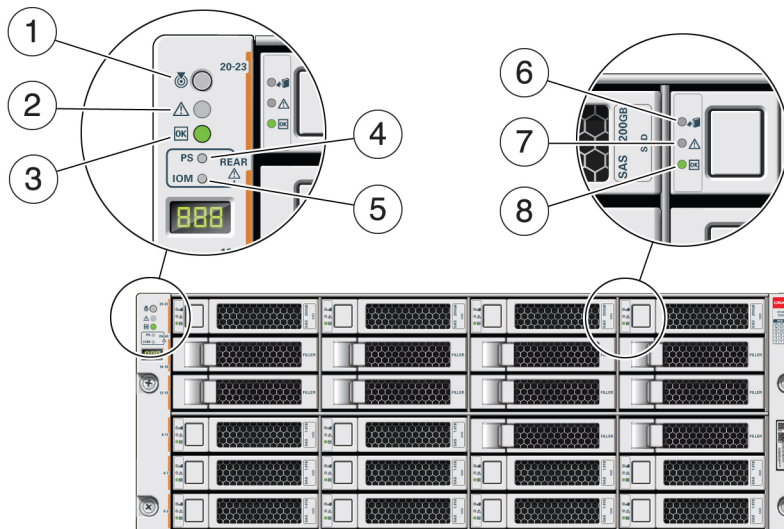

Callout	Indicator/LED: Color	State Meaning
1	Locate: white	<ul style="list-style-type: none"> <li>Off - Normal operation.</li> <li>Fast blink - This LED blinks to help locate the system. Operators can turn this indicator on and off remotely using Oracle ILOM.</li> <li>Pressing this button toggles the fast blink on or off.</li> </ul>
2	Service Required: amber	<ul style="list-style-type: none"> <li>Off - Normal operation.</li> <li>Steady on - A fault is present in the storage shelf.</li> </ul>
3	OK: green	<ul style="list-style-type: none"> <li>On - The storage shelf is powered on and operating normally.</li> <li>Off - The storage shelf is unplugged or turned off.</li> </ul>
4	Power Supply fault indicator: amber	<ul style="list-style-type: none"> <li>On - Indicates a fault with a power supply. View the LEDs at the back of the storage shelf to determine which power supply has the fault.</li> <li>Off - Normal operation.</li> </ul>
5	SAS I/O Module fault indicator: amber	<ul style="list-style-type: none"> <li>On - Indicates a fault with a SAS I/O module. View the LEDs at the back of the storage shelf to determine which module has the fault.</li> <li>Off - Normal operation.</li> </ul>
6	Ready-to-Remove: blue	<ul style="list-style-type: none"> <li>Off - Normal operation.</li> <li>On - The storage drive can be safely removed during a hot-plug operation.</li> <li>Off - The storage drive has not been prepared for removal.</li> </ul>
7	Drive Service Required: amber	<ul style="list-style-type: none"> <li>Off - Normal operation.</li> <li>Steady on - A fault is present in the disk drive.</li> </ul>

Callout	Indicator/LED: Color	State Meaning
8	Power/Activity: green	<ul style="list-style-type: none"> <li>On - The drive is installed and recognized by the system but there is no drive activity.</li> <li>Blink - The LED blinks randomly in response to data being written to or read from the drive.</li> <li>Off - The drive is powered off or the installed drive is not recognized by the system.</li> </ul>

### 1.4.2.2 Storage Shelf Back Panel Status Indicators

See a listing of the various back panel status indicators for the Oracle Database Appliance X6-2-HA storage shelf.

The following figure shows the controls and indicators on the Oracle Database Appliance X6-2-HA storage shelf (DE3-24C) back panel.

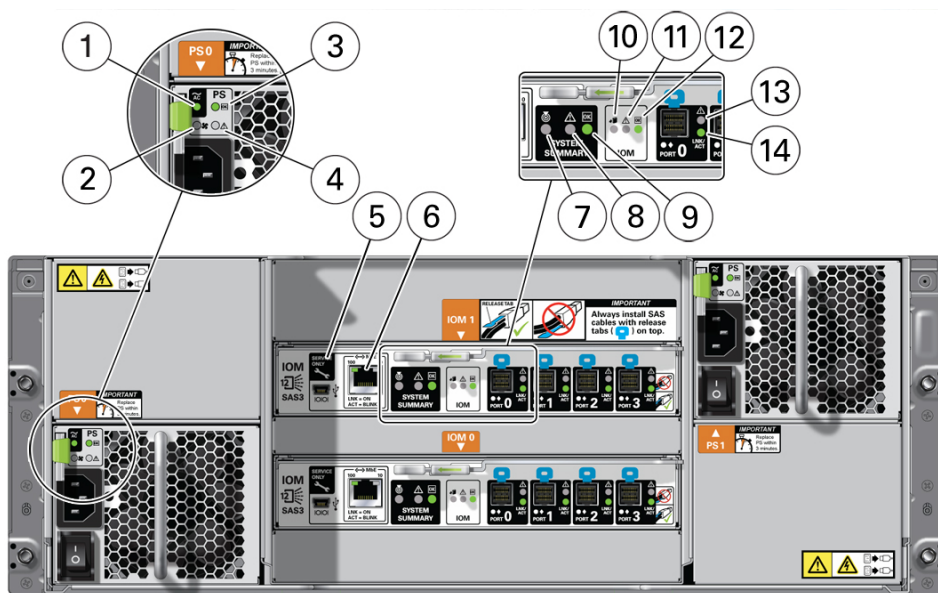

Callout	Indicator/LED: Color	State Meaning
1	AC power fault indicator: amber	<ul style="list-style-type: none"> <li>On - Indicates an AC power fault.</li> <li>Off - Normal operation.</li> </ul>
2	Fan fail indicator: amber	<ul style="list-style-type: none"> <li>On - The fan is faulty.</li> <li>Off - Normal operation.</li> </ul>
3	Power supply status indicator: green	<ul style="list-style-type: none"> <li>On - The power supply is operating normally.</li> <li>Off - The power supply is unplugged or turned off.</li> </ul>
4	DC power fail indicator: amber	<ul style="list-style-type: none"> <li>On - The power supply is faulty.</li> <li>Off - Normal operation.</li> </ul>

Callout	Indicator/LED: Color	State Meaning
5	Reserved	This port is reserved for Oracle Service.
6	Network port (reserved)	This port is reserved for Oracle Service.
7	Locate: white	<ul style="list-style-type: none"> <li>Off - Normal operation.</li> <li>Fast blink - This LED blinks to help locate the system. Operators can turn this indicator on and off remotely using Oracle ILOM.</li> <li>Pressing this button toggles the fast blink on or off.</li> </ul>
8	Service Required: amber	<ul style="list-style-type: none"> <li>Off - Normal operation.</li> <li>Steady on - A fault is present in the storage shelf.</li> </ul>
9	OK: green	<ul style="list-style-type: none"> <li>On - The storage shelf is powered on and operating normally.</li> <li>Off - The storage shelf is unplugged or turned off.</li> </ul>
10	SAS I/O Module Ready-to-Remove: blue	<ul style="list-style-type: none"> <li>On - The I/O module can be safely removed during a hot-plug operation.</li> <li>Off - The I/O module has not been prepared for removal.</li> </ul>
11	SAS I/O Module Service Required indicator: amber	<ul style="list-style-type: none"> <li>Off - Normal operation.</li> <li>Steady on - A fault is present in the SAS I/O module.</li> </ul>
12	SAS I/O Module OK: green	<ul style="list-style-type: none"> <li>On - The I/O module is powered on and operating normally.</li> <li>Off - The I/O module is unplugged or turned off.</li> </ul>
13	Host SAS port Service Required indicator: amber	<ul style="list-style-type: none"> <li>Off - Normal operation.</li> <li>Steady on - A fault is present with the port or connection.</li> </ul>
14	Host SAS port activity indicator: green	<ul style="list-style-type: none"> <li>Random blinking - Indicates host SAS link activity.</li> <li>Off - No link activity.</li> </ul>

## 1.5 Oracle Database Appliance X5-2 Status Indicators

Learn about Oracle Database Appliance X5-2 status indicators.

- [Oracle Database Appliance X5-2 Server Node Status Indicators](#) (page 1-29)  
See a description of the Oracle Database Appliance X5-2 server node front and back status indicators.
- [Oracle Database Appliance X5-2 Storage Shelf Indicators](#) (page 1-33)  
See a description of the front and back Oracle Database Appliance X5-2 storage shelf status indicators.

### 1.5.1 Oracle Database Appliance X5-2 Server Node Status Indicators

See a description of the Oracle Database Appliance X5-2 server node front and back status indicators.

- [Server Node Front Panel Status Indicators](#) (page 1-30)  
See a listing of the various front panel status indicators for the Oracle Database Appliance X5-2 server node.
- [Server Node Back Panel Status Indicators](#) (page 1-32)  
See a listing of the various back panel status indicators for the Oracle Database Appliance X5-2 server node.

### 1.5.1.1 Server Node Front Panel Status Indicators

See a listing of the various front panel status indicators for the Oracle Database Appliance X5-2 server node.

The following figure shows the Oracle Database Appliance X5-2 server node front panel and includes indicators for the system and storage drives.

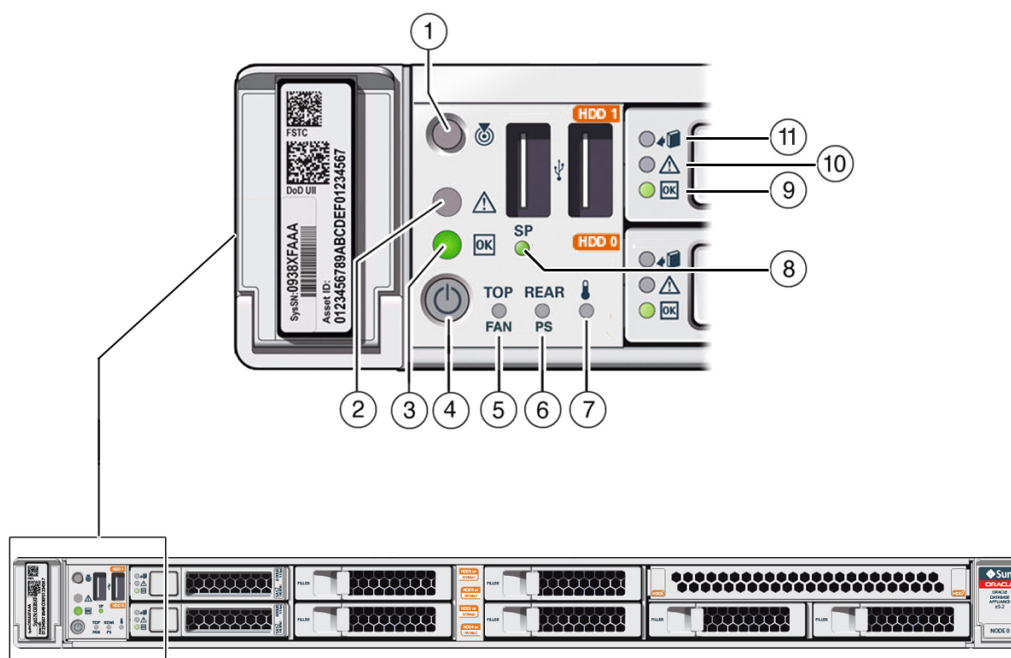

Callout	Indicator/LED: Color	State Meaning
1	Locate: white	<ul style="list-style-type: none"> <li>• Off - Normal operation.</li> <li>• Fast blink - This LED blinks to help locate the system. Operators can turn this indicator on and off remotely using Oracle ILOM.</li> <li>• Pressing this button toggles the fast blink on or off.</li> </ul>
2	Service Required: amber	<ul style="list-style-type: none"> <li>• Off - Normal operation.</li> <li>• On - A fault is present in the server node.</li> </ul> <p>The lighting of this indicator is always accompanied by a system console message that includes a recommended service action.</p>

Callout	Indicator/LED: Color	State Meaning
3	OK: green	<p>Indicates the operational state of the server node:</p> <ul style="list-style-type: none"> <li>On - The server is powered on, and all host POST code checkpoint tests are complete. The server is in one of the following states: 1) the server host is booting the operating system (OS), 2) the server host is running the OS.</li> <li>Off - AC power is not present or the Oracle ILOM boot is not complete.</li> <li>Steady blink - Standby power is on, but the chassis power is off and the Oracle ILOM SP is running.</li> <li>Slow blink - Startup sequence has been initiated on the host. This pattern should begin soon after you power on the server. This status indicates either: (1) POST code checkpoint tests are running on the server host system, or (2) the host is transitioning from the powered-on state to the standby state on shutdown.</li> </ul>
4	Power button	<p>Press to apply full power. Press again to turn main power off, but leave standby power on the Oracle ILOM.</p>
5	Top fan: amber	<p>Indicates that one (or more) of the internal fan modules has failed.</p> <ul style="list-style-type: none"> <li>Off - Indicates steady state; no service is required.</li> <li>On - Indicates service required; service the failed fan module.</li> </ul>
6	Rear PS: amber	<p>Indicates that one (or more) of the power supplies has failed.</p> <ul style="list-style-type: none"> <li>Off - Indicates steady state; no service is required.</li> <li>On - Indicates service required; service the failed power supply.</li> </ul>
7	Over temperature warning: amber	<ul style="list-style-type: none"> <li>Off - Normal operation; no service is required.</li> <li>On - The system is experiencing an over temperature warning condition.</li> </ul> <p>This is a warning indication, not a fatal over temperature. Failure to correct this condition might result in the system overheating and shutting down unexpectedly.</p>
8	Service processor (SP): green	<ul style="list-style-type: none"> <li>Off - The service processor (SP) is not running.</li> <li>On - The SP is fully operational.</li> <li>Slow blink - SP is booting.</li> </ul>

Callout	Indicator/LED: Color	State Meaning
9	Drive OK: green	<ul style="list-style-type: none"> <li>Off - Power is off or the installed drive is not recognized by the system.</li> <li>On - The drive is engaged and is receiving power.</li> <li>Random blink - There is disk activity. The indicator blinks on and off to indicate activity.</li> </ul>
10	Drive Service Required: amber	<ul style="list-style-type: none"> <li>Off - The storage drive is operating normally.</li> <li>On - The system has detected a fault with the storage drive.</li> </ul>
11	Drive Ready-to-Remove: blue	<ul style="list-style-type: none"> <li>Off - The storage drive has not been prepared for removal.</li> <li>On - The storage drive can be removed safely during a hot-plug operation.</li> </ul>

### 1.5.1.2 Server Node Back Panel Status Indicators

See a listing of the various back panel status indicators for the Oracle Database Appliance X5-2 server node.

The following figure shows the Oracle Database Appliance X5-2 server node back panel and includes indicators for the system, power supplies and network ports

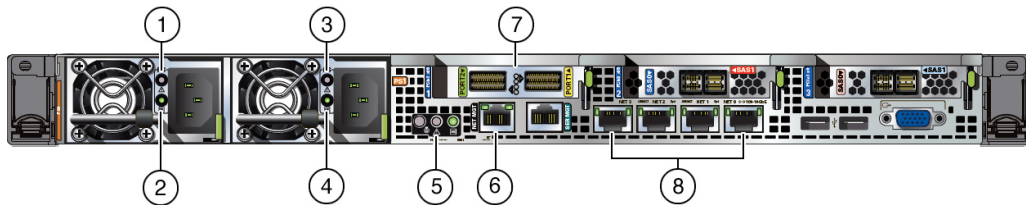

Callout	Indicator/LED: Color	State Meaning
1, 3	PS Service Required: amber	<ul style="list-style-type: none"> <li>Off - Normal operation.</li> <li>On - The power supply (PS) has detected a PS fan failure, PS overtemperature, PS over current, or PS over or under voltage.</li> </ul>
2, 4	PS OK: green	<ul style="list-style-type: none"> <li>Off - No AC power is present.</li> <li>On - Normal operation. Input AC power and DC output voltage are within specification.</li> <li>Slow blink - Normal operation. Input power is within specification. DC output voltage is not enabled.</li> </ul>
5	System locate, service required and OK: various	These operate in the same way as on the front panel.

Callout	Indicator/LED: Color	State Meaning
6	NET MGT port: green	<p>10/100/1000 BASE-T Ethernet management interface.</p> <p>Top left link indicator:</p> <ul style="list-style-type: none"> <li>On - Green for 1000Base-T link.</li> <li>Off - 10/100BASE-T link.</li> </ul> <p>Top right activity indicator:</p> <ul style="list-style-type: none"> <li>On - Link up.</li> <li>Off - No link or link down.</li> <li>Blinking - Packet activity.</li> </ul>
7	Two InfiniBand QSFP+ Adapter ports (shown): green/yellow	<p>InfiniBand QSFP+ interface.</p> <ul style="list-style-type: none"> <li>Green on - InfiniBand physical link established.</li> <li>Green off - No link.</li> <li>Yellow on - InfiniBand is discovered over the link, but no data is being passed .</li> <li>Yellow off - A physical and/or logical link has not been established.</li> <li>Yellow blinking - Data being passed.</li> </ul>
8	NET 0-3 ports: green/amber	<p>100/1000 BASE-T Ethernet management interface.</p> <p>Top left activity indicator:</p> <ul style="list-style-type: none"> <li>On - No function.</li> <li>Off - No activity.</li> <li>Blinking - Packet activity.</li> </ul> <p>Top right link indicator:</p> <ul style="list-style-type: none"> <li>On - Amber for 100 base-T link; green for 1000 base-T link.</li> <li>Off - No link.</li> <li>Blinking - No function.</li> </ul>

## 1.5.2 Oracle Database Appliance X5-2 Storage Shelf Indicators

See a description of the front and back Oracle Database Appliance X5-2 storage shelf status indicators.

- [Storage Shelf Front Panel Status Indicators](#) (page 1-33)  
See a listing of the various front panel status indicators for the Oracle Database Appliance X5-2 storage shelf.
- [Storage Shelf Back Panel Status Indicators](#) (page 1-35)  
See a listing of the various back panel status indicators for the Oracle Database Appliance X5-2 storage shelf.

### 1.5.2.1 Storage Shelf Front Panel Status Indicators

See a listing of the various front panel status indicators for the Oracle Database Appliance X5-2 storage shelf.

The following figure shows the controls and indicators on the Oracle Database Appliance X5-2 storage shelf (DE2-24C) front panel and drives.



 **Note:**

The 2 or 3 character LED enclosure ID display panel on the front of the storage shelf is not used with the Oracle Database Appliance product. Any numbers or letters displayed in this panel other than zeros could indicate a fault with either the panel, its cabling (neither of which are customer replaceable), or some other storage shelf component.

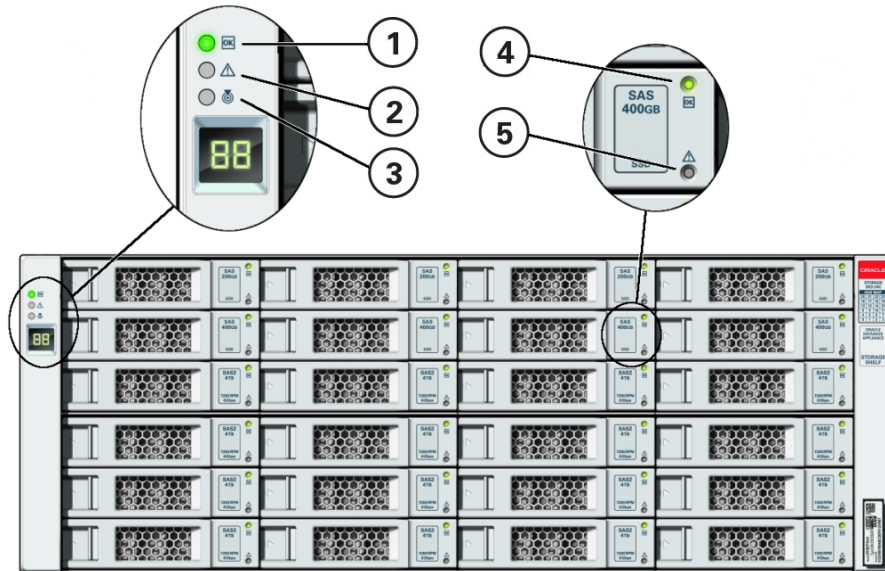

Callout	Indicator/LED: Color	State Meaning
1	OK: green	<ul style="list-style-type: none"> <li>On - The storage shelf is powered on and operating normally.</li> <li>Off - The storage shelf is unplugged or turned off.</li> </ul>
2	Service Required: amber	<ul style="list-style-type: none"> <li>Off - Normal operation.</li> <li>Steady on - A fault is present in the storage shelf.</li> </ul>
3	Locate: white	<ul style="list-style-type: none"> <li>Off - Normal operation.</li> <li>Fast blink - This LED blinks to help locate the system. Operators can turn this indicator on and off remotely using Oracle ILOM.</li> <li>Pressing this button toggles the fast blink on or off.</li> </ul>

Callout	Indicator/LED: Color	State Meaning
4	Power/Activity: green	<ul style="list-style-type: none"> <li>On - The drive is installed and recognized by the system but there is no drive activity.</li> <li>Blink - The LED blinks randomly in response to data being written to or read from the drive.</li> <li>Off - The drive is powered off or the installed drive is not recognized by the system.</li> </ul>
5	Drive Service Required: amber	<ul style="list-style-type: none"> <li>Off - Normal operation.</li> <li>Steady on - A fault is present in the disk drive.</li> </ul>

### 1.5.2.2 Storage Shelf Back Panel Status Indicators

See a listing of the various back panel status indicators for the Oracle Database Appliance X5-2 storage shelf.

The following figure shows the controls and indicators on the Oracle Database Appliance X5-2 storage shelf (DE2-24C) back panel.

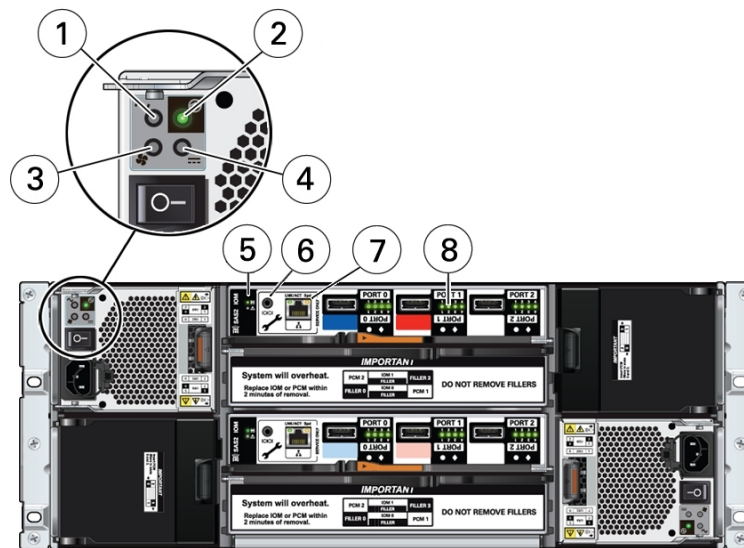

Callout	Indicator/LED: Color	State Meaning
1	AC power fault indicator: amber	<ul style="list-style-type: none"> <li>On - Indicates an AC power fault.</li> <li>Off - Normal operation.</li> </ul>
2	Power supply status indicator: green	<ul style="list-style-type: none"> <li>On - The power supply is operating normally.</li> <li>Off - The power supply is unplugged or turned off.</li> </ul>
3	Fan fail indicator: amber	<ul style="list-style-type: none"> <li>On - The fan is faulty.</li> <li>Off - Normal operation.</li> </ul>

Callout	Indicator/LED: Color	State Meaning
4	DC power fail indicator: amber	<ul style="list-style-type: none"> <li>On - The power supply is faulty.</li> <li>Off - Normal operation.</li> </ul>
5	SAS I/O Module status indicators: green or amber	<ul style="list-style-type: none"> <li>OK - Lights green to indicate normal operation.</li> <li>Service Required - Lights amber to indicate a fault with the I/O module (top module is 0; bottom module is 1).</li> </ul>
6	Reserved	This port is reserved for Oracle Service.
7	Network port (reserved)	This port is reserved for Oracle Service.
8	Host SAS port activity indicators (x4 per port): green	<ul style="list-style-type: none"> <li>Random blinking - Indicates host SAS link activity.</li> <li>Off - No link activity.</li> </ul>

## 1.6 Oracle Database Appliance X3-2/X4-2 Status Indicators

Learn about Oracle Database Appliance X3-2/X4-2 status indicators.

- [Oracle Database Appliance X3-2/X4-2 Server Node Status Indicators](#) (page 1-36)  
See a description of the Oracle Database Appliance X3-2/X4-2 server node front and back status indicators.
- [Oracle Database Appliance X3-2/X4-2 Storage Shelf Indicators](#) (page 1-40)  
See a description of the front and back Oracle Database Appliance X3-2/X4-2 storage shelf status indicators.

### 1.6.1 Oracle Database Appliance X3-2/X4-2 Server Node Status Indicators

See a description of the Oracle Database Appliance X3-2/X4-2 server node front and back status indicators.

- [Server Node Front Panel Status Indicators](#) (page 1-36)  
See a listing of the various front panel status indicators for the Oracle Database Appliance X3-2/X4-2 server node.
- [Server Node Back Panel Status Indicators](#) (page 1-39)  
See a listing of the various back panel status indicators for the Oracle Database Appliance X3-2/X4-2 server node.

#### 1.6.1.1 Server Node Front Panel Status Indicators

See a listing of the various front panel status indicators for the Oracle Database Appliance X3-2/X4-2 server node.

The following figure shows the Oracle Database Appliance X3-2/X4-2 server node front panel and includes indicators for the system and storage drives.

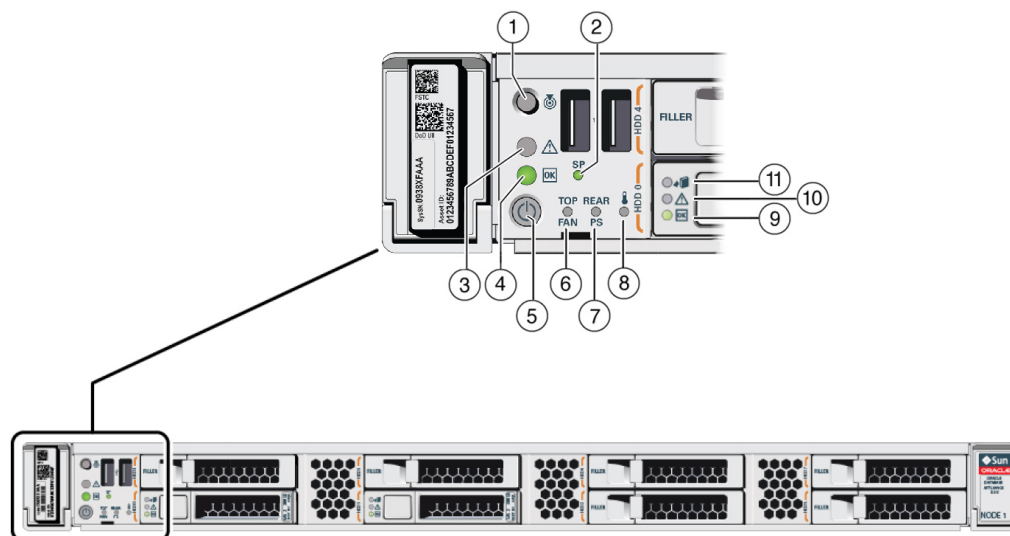

Callout	Indicator/LED: Color	State Meaning
1	Locate: white	<ul style="list-style-type: none"> <li>Off - Normal operation.</li> <li>Fast blink - This LED blinks to help locate the system. Operators can turn this indicator on and off remotely using Oracle ILOM.</li> <li>Pressing this button toggles the fast blink on or off.</li> </ul>
2	Service processor (SP): green	<ul style="list-style-type: none"> <li>Off - The service processor (SP) is not running.</li> <li>On - The SP is fully operational.</li> <li>Slow blink - SP is booting.</li> </ul>
3	Service Required: amber	<ul style="list-style-type: none"> <li>Off - Normal operation.</li> <li>On - A fault is present in the server node.</li> </ul> <p>The lighting of this indicator is always accompanied by a system console message that includes a recommended service action.</p>

Callout	Indicator/LED: Color	State Meaning
4	OK: green	<p>Indicates the operational state of the server node:</p> <ul style="list-style-type: none"> <li>On - The server is powered on, and all host POST code checkpoint tests are complete. The server is in one of the following states: 1) the server host is booting the operating system (OS), 2) the server host is running the OS.</li> <li>Off - AC power is not present or the Oracle ILOM boot is not complete.</li> <li>Steady blink - Standby power is on, but the chassis power is off and the Oracle ILOM SP is running.</li> <li>Slow blink - Startup sequence has been initiated on the host. This pattern should begin soon after you power on the server. This status indicates either: (1) POST code checkpoint tests are running on the server host system, or (2) the host is transitioning from the powered-on state to the standby state on shutdown.</li> </ul>
5	Power button	Press to apply full power. Press again to turn main power off, but leave standby power on the Oracle ILOM.
6	Top fan: amber	<p>Indicates that one (or more) of the internal fan modules has failed.</p> <ul style="list-style-type: none"> <li>Off - Indicates steady state; no service is required.</li> <li>On - Indicates service required; service the failed fan module.</li> </ul>
7	Rear PS: amber	<p>Indicates that one (or more) of the power supplies has failed.</p> <ul style="list-style-type: none"> <li>Off - Indicates steady state; no service is required.</li> <li>On - Indicates service required; service the failed power supply.</li> </ul>
8	Over temperature warning: amber	<ul style="list-style-type: none"> <li>Off - Normal operation; no service is required.</li> <li>On - The system is experiencing an over temperature warning condition.</li> </ul> <p>This is a warning indication, not a fatal over temperature. Failure to correct this condition might result in the system overheating and shutting down unexpectedly.</p>

Callout	Indicator/LED: Color	State Meaning
9	Drive OK: green	<ul style="list-style-type: none"> <li>Off - Power is off or the installed drive is not recognized by the system.</li> <li>On - The drive is engaged and is receiving power.</li> <li>Random blink - There is disk activity. The indicator blinks on and off to indicate activity.</li> </ul>
10	Drive Service Required: amber	<ul style="list-style-type: none"> <li>Off - The storage drive is operating normally.</li> <li>On - The system has detected a fault with the storage drive.</li> </ul>
11	Drive Ready-to-Remove: blue	<ul style="list-style-type: none"> <li>Off - The storage drive has not been prepared for removal.</li> <li>On - The storage drive can be removed safely during a hot-plug operation.</li> </ul>

### 1.6.1.2 Server Node Back Panel Status Indicators

See a listing of the various back panel status indicators for the Oracle Database Appliance X3-2/X4-2 server node.

The following figure shows the Oracle Database Appliance X3-2/X4-2 server node back panel and includes indicators for the system, power supplies and network ports.

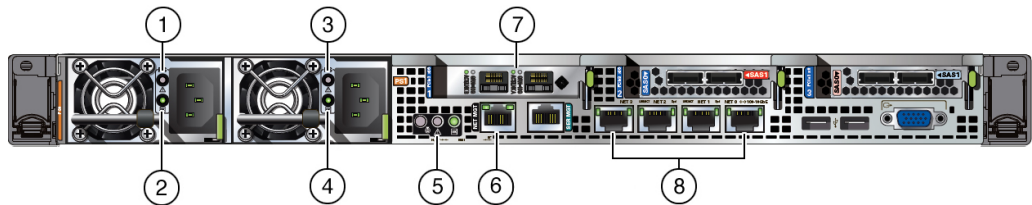

Callout	Indicator/LED: Color	State Meaning
1, 3	PS Service Required: amber	<ul style="list-style-type: none"> <li>Off - Normal operation.</li> <li>On - The power supply (PS) has detected a PS fan failure, PS overtemperature, PS over current, or PS over or under voltage.</li> </ul>
2, 4	PS OK: green	<ul style="list-style-type: none"> <li>Off - No AC power is present.</li> <li>On - Normal operation. Input AC power and DC output voltage are within specification.</li> <li>Slow blink - Normal operation. Input power is within specification. DC output voltage is not enabled.</li> </ul>
5	System locate, service required and OK: various	These operate in the same way as on the front panel.

Callout	Indicator/LED: Color	State Meaning
6	NET MGT port: green/amber	<p>10/100 BASE-T Ethernet management interface.</p> <p>Top left link indicator:</p> <ul style="list-style-type: none"> <li>On - Amber for 10Base-T link; green for 100Base-T link.</li> <li>Off - No link or link down.</li> </ul> <p>Top right activity indicator:</p> <ul style="list-style-type: none"> <li>On - No function.</li> <li>Off - No activity.</li> <li>Blinking - Packet activity.</li> </ul>
7	<p><b>Oracle Database Appliance X4-2:</b> Dual 10 GbE SFP+ PCIe 2.0 Low Profile Adapter ports (shown): green/amber --or--</p> <p><b>Oracle Database Appliance X3-2:</b> Sun Dual Port 10GBase-T Adapter ports (not shown): green/yellow</p>	<p><b>Oracle Database Appliance X4-2</b> with 1000/10000 BASE-T SFP+ Ethernet management interface.</p> <ul style="list-style-type: none"> <li>GRN=10G: <ul style="list-style-type: none"> <li>On - Green for 10GbE link; amber for 1GbE link.</li> <li>Off - No function.</li> </ul> </li> <li>ACT/LINK (A or B): <ul style="list-style-type: none"> <li>On - Green for link up.</li> <li>Off - No link.</li> <li>Blinking - Green for packet activity.</li> </ul> </li> </ul> <p><b>Oracle Database Appliance X3-2</b> with 1000/10000 BASE-T Ethernet management interface.</p> <ul style="list-style-type: none"> <li>1G/100M=YLW: <ul style="list-style-type: none"> <li>On - Green for 1GbE link; yellow for 10GbE link.</li> <li>Off - No link.</li> </ul> </li> <li>ACT/LINK: <ul style="list-style-type: none"> <li>On - Green for link up.</li> <li>Off - No link.</li> <li>Blinking - Green for packet activity.</li> </ul> </li> </ul>
8	NET 0-3 ports: green/amber	<p>100/1000 BASE-T Ethernet management interface.</p> <p>Top left activity indicator:</p> <ul style="list-style-type: none"> <li>On - No function.</li> <li>Off - No activity.</li> <li>Blinking - Packet activity.</li> </ul> <p>Top right link indicator:</p> <ul style="list-style-type: none"> <li>On - Amber for 100Base-T link; green for 1000/10GBase-T link.</li> <li>Off - No link.</li> <li>Blinking - No function.</li> </ul>

## 1.6.2 Oracle Database Appliance X3-2/X4-2 Storage Shelf Indicators

See a description of the front and back Oracle Database Appliance X3-2/X4-2 storage shelf status indicators.

- [Storage Shelf Front Panel Status Indicators](#) (page 1-41)  
See a listing of the various front panel status indicators for the Oracle Database Appliance X3-2/X4-2 storage shelf.
- [Storage Shelf Back Panel Status Indicators](#) (page 1-42)  
See a listing of the various back panel status indicators for the Oracle Database Appliance X3-2/X4-2 storage shelf.

### 1.6.2.1 Storage Shelf Front Panel Status Indicators

See a listing of the various front panel status indicators for the Oracle Database Appliance X3-2/X4-2 storage shelf.

The following figure shows the controls and indicators on the Oracle Database Appliance X3-2/X4-2 storage shelf (DE2-24P) front panel and drives.

 **Note:**

The 2 or 3 character LED enclosure ID display panel on the front of the storage shelf is not used with the Oracle Database Appliance product. Any numbers or letters displayed in this panel other than zeros could indicate a fault with either the panel, its cabling (neither of which are customer replaceable), or some other storage shelf component.

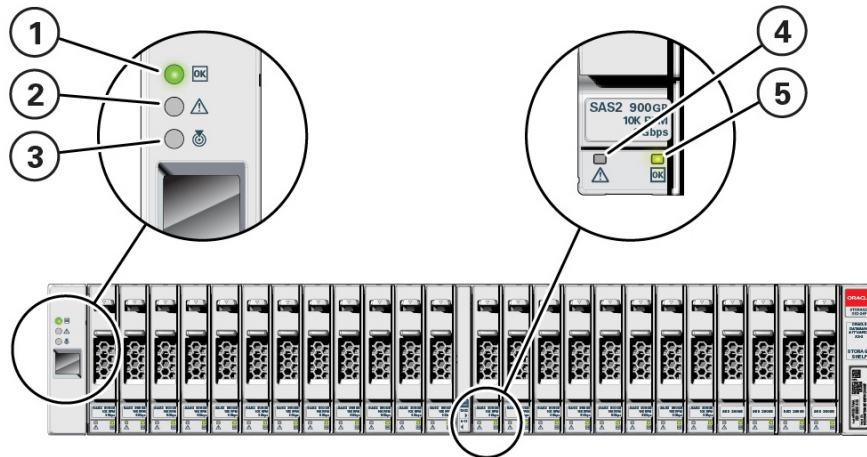

Callout	Indicator/LED: Color	State Meaning
1	OK: green	<ul style="list-style-type: none"> <li>• On - The storage shelf is powered on and operating normally.</li> <li>• Off - The storage shelf is unplugged or turned off.</li> </ul>
2	Service Required: amber	<ul style="list-style-type: none"> <li>• Off - Normal operation.</li> <li>• Steady on - A fault is present in the storage shelf.</li> </ul>



Callout	Indicator/LED: Color	State Meaning
3	Locate: white	<ul style="list-style-type: none"> <li>Off - Normal operation.</li> <li>Fast blink - This LED blinks to help locate the system. Operators can turn this indicator on and off remotely using Oracle ILOM.</li> <li>Pressing this button toggles the fast blink on or off.</li> </ul>
4	Drive Service Required: amber	<ul style="list-style-type: none"> <li>Off - Normal operation.</li> <li>Steady on - A fault is present in the disk drive.</li> </ul>
5	Power/Activity: green	<ul style="list-style-type: none"> <li>On - The drive is installed and recognized by the system but there is no drive activity.</li> <li>Blink - The LED blinks randomly in response to data being written to or read from the drive.</li> <li>Off - The drive is powered off or the installed drive is not recognized by the system.</li> </ul>

### 1.6.2.2 Storage Shelf Back Panel Status Indicators

See a listing of the various back panel status indicators for the Oracle Database Appliance X3-2/X4-2 storage shelf.

The following figure shows the controls and indicators on the Oracle Database Appliance X3-2/X4-2 storage shelf (DE2-24P) back panel.

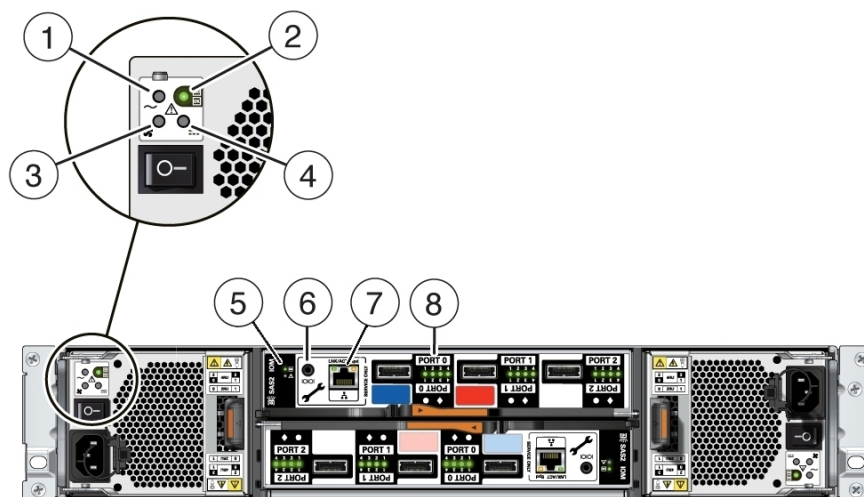

Callout	Indicator/LED: Color	State Meaning
1	AC power fault indicator: amber	<ul style="list-style-type: none"> <li>On - Indicates an AC power fault.</li> <li>Off - Normal operation.</li> </ul>

Callout	Indicator/LED: Color	State Meaning
2	Power supply status indicator: green	<ul style="list-style-type: none"> <li>On - The power supply is operating normally.</li> <li>Off - The power supply is unplugged or turned off.</li> </ul>
3	Fan fail indicator: amber	<ul style="list-style-type: none"> <li>On - The fan is faulty.</li> <li>Off - Normal operation.</li> </ul>
4	DC power fail indicator: amber	<ul style="list-style-type: none"> <li>On - The power supply is faulty.</li> <li>Off - Normal operation.</li> </ul>
5	SAS I/O Module status indicators: green or amber	<ul style="list-style-type: none"> <li>OK - Lights green to indicate normal operation.</li> <li>Service Required - Lights amber to indicate a fault with the I/O module (top module is 0; bottom module is 1).</li> </ul>
6	Reserved	This port is reserved for Oracle Service.
7	Network port (reserved)	This port is reserved for Oracle Service.
8	Host SAS port activity indicators (x4 per port): green	<ul style="list-style-type: none"> <li>Random blinking - Indicates host SAS link activity.</li> <li>Off - No link activity.</li> </ul>

## 1.7 Oracle Database Appliance Version 1 Status Indicators

Learn about Oracle Database Appliance Version 1 front and back status indicators.

- [Server Node Front Status Indicators](#) (page 1-44)  
See a listing of the various system status indicators at the front of an Oracle Database Appliance Version 1 server node.
- [Server Node Fan Status Indicators](#) (page 1-46)  
See a listing of the various status indicators for an Oracle Database Appliance Version 1 server node fans.
- [Server Node Storage and Boot Drive Status Indicators](#) (page 1-47)  
See a listing of the various status indicators for an Oracle Database Appliance Version 1 server node storage drives.
- [Server Node Power Supply Status Indicators](#) (page 1-47)  
See a listing of the various status indicators for an Oracle Database Appliance Version 1 server node power supply.
- [Server Node Rear Status Indicators](#) (page 1-48)  
See a listing of the various system status indicators at the rear of an Oracle Database Appliance Version 1 server node.
- [Server Node Internal LEDs](#) (page 1-50)  
See a listing of the various internal status indicators (LEDs) for an Oracle Database Appliance Version 1 server node.
- [Server Node Ethernet Port Status Indicators](#) (page 1-51)  
See a listing of the various Ethernet port status indicators at the rear of an Oracle Database Appliance Version 1 server node.

## 1.7.1 Server Node Front Status Indicators

See a listing of the various system status indicators at the front of an Oracle Database Appliance Version 1 server node.

The following figure shows the general status indicators on the front panel of each Oracle Database Appliance Version 1 server node.

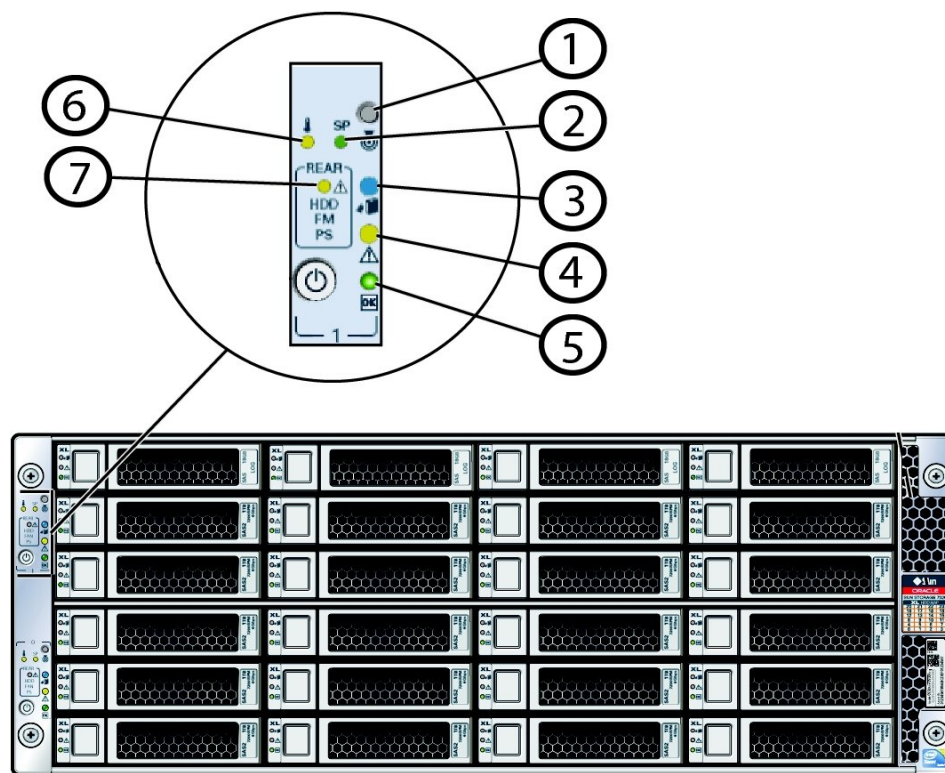

Callout	Indicator/LED: Color	State Meaning
1	Locate button/LED: white	<ul style="list-style-type: none"> <li>Off - Normal operation.</li> <li>Fast blink - This LED blinks to help locate the system. Operators can turn this indicator on and off remotely using Oracle ILOM.</li> <li>Pressing this button toggles the fast blink on or off. It is also used to prove physical presence.</li> <li>Indicator Test Mode - Push and hold the Locate button for 5 seconds to activate the push to test feature, which causes all LEDs except disk activity and power supply LEDs to light for 15 seconds.</li> </ul>

Callout	Indicator/LED: Color	State Meaning
2	SP OK/Fault: bi-color	<ul style="list-style-type: none"> <li>Off - No power is supplied to the SP or it is not functional.</li> <li>Amber - When lit indicates an SP fault.</li> <li>Green - When steady on indicates that Oracle ILOM is fully functional. If blinking, POST diagnostics are running, Oracle ILOM is booting, or firmware is updating.</li> </ul> <p>The amber LED indicates the status of the watchdog timer. The watchdog timer runs continuously, but it times out if it is not reset by Oracle ILOM. If it times out, the amber LED is lit and the green LED is extinguished.</p>
3	Ready to Remove: blue	<ul style="list-style-type: none"> <li>Off - Normal operation.</li> <li>Fast Blink - The system is preparing a customer-replaceable unit (CRU) (disk drive, fan module, or power supply) for safe removal but it is not ready yet.</li> <li>Steady on - The CRU can be safely removed.</li> </ul>
4	Service Required: amber	<ul style="list-style-type: none"> <li>Off - Normal operation.</li> <li>Steady on - A fault is present in system or a subsystem within the chassis.</li> </ul>
5	Power/OK: green	<p>This LED indicates the operational state of the chassis. This LED can be in the following states:</p> <ul style="list-style-type: none"> <li>Off - AC power is not present or the Oracle ILOM boot has not completed.</li> <li>Standby blink - Standby power is on and Oracle ILOM can be accessed, but full chassis power is off. The LED blinks at a 10 percent duty cycle (0.1 second on, 2.9 seconds off), that is, the light is on for a very short period of time.</li> <li>Slow blink - The startup sequence has been initiated on the host. The LED blinks at a 50 percent duty cycle, which is noticeably longer than the STANDBY BLINK. This pattern should begin immediately following powering on the system. This status indicates either 1) power-on self-test (POST) diagnostics running on system host or 2) the host is transitioning from the powered-on state to the standby state on shutdown.</li> <li>Steady on - The system is powered on and all host POST tests passed. The system is one of the following states: 1) the system host is ready to boot, or 2) the system host is booting the operating system (OS), or 3) the system host is running the OS.</li> </ul>
6	Over temperature: amber	<ul style="list-style-type: none"> <li>Off - Normal operation.</li> <li>Steady on - The system is experiencing an over-temperature warning condition.</li> </ul> <p>This is a warning indication, not a fatal over temperature. Failure to correct this can result in the system over heating and shutting down.</p>

Callout	Indicator/LED: Color	State Meaning
7	Rear Component Failure: amber	<ul style="list-style-type: none"> <li>Off - Normal operation.</li> <li>Steady on - The system has detected a power supply fault, a fan fault, or a rear 2.5-inch disk drive fault.</li> </ul> <p>This fault condition is associated with chassis components located in the rear of the chassis. This fault might be caused by:</p> <ul style="list-style-type: none"> <li>Power supply failure (AC fault, 12V/3.3Vaux fault, or power supply fan fault)</li> <li>Rear fan failure</li> <li>Rear 2.5-inch disk failure</li> </ul>

## 1.7.2 Server Node Fan Status Indicators

See a listing of the various status indicators for an Oracle Database Appliance Version 1 server node fans.

Each fan module for Oracle Database Appliance Version 1 has a single bi-colored LED indicating both fan OK and fan fault conditions. The LED lights green to indicate that the fan module is properly plugged into the system and operating within the expected RPM range for a given power management setting. The LED lights amber to indicate a fan fault.

### Note:

The LEDs on the fan modules are not lit amber on initial system power-on. The fan amber LED only lights if Oracle ILOM detects a failure that indicates a faulty fan module or a missing fan that should be installed.

The following figure shows the fan module status indicators viewable from the rear of each server node.

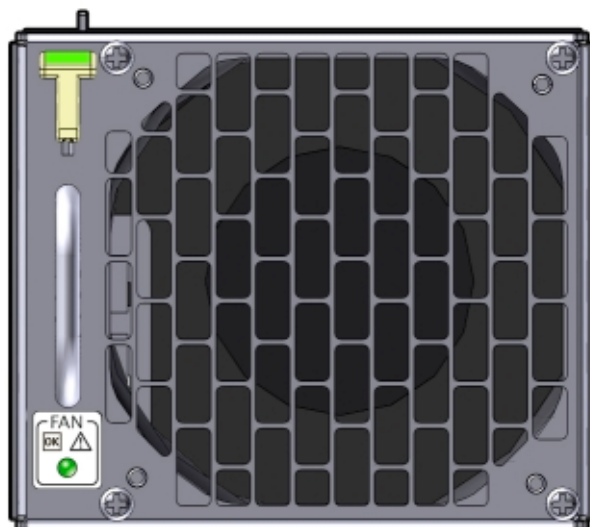

Indicator/LED: Color	State Meaning
OK: green	<ul style="list-style-type: none"> <li>Steady on - The fan is functioning normally.</li> <li>Off - Chassis 3.3V_Standby power is off or there is a fan fault.</li> </ul>
Service Required: amber	<ul style="list-style-type: none"> <li>Off - Normal operation.</li> <li>Steady on - A fault has been detected with the fan.</li> </ul> <p>The front and rear panel Service Required LEDs are also lit if the system detects a fan module fault.</p>

### 1.7.3 Server Node Storage and Boot Drive Status Indicators

See a listing of the various status indicators for an Oracle Database Appliance Version 1 server node storage drives.

Each storage drive for Oracle Database Appliance Version 1 includes three LEDs. They are the same on the front storage drives and the rear-mounted boot drives.

The following figure shows the storage and boot drive status indicators for a server node.



Callout	Indicator/LED: Color	State Meaning
1	Ready to Remove: blue	<ul style="list-style-type: none"> <li>Off - Normal operation.</li> <li>Fast blink - The system is preparing a disk drive for safe removal but it is not ready yet.</li> <li>Steady on - The disk drive can be safely removed.</li> </ul>
2	Service Required: amber	<ul style="list-style-type: none"> <li>Off - Normal operation.</li> <li>Steady on - A fault is present in the disk drive.</li> </ul>
3	OK/Activity: green	<ul style="list-style-type: none"> <li>On - The drive is installed and recognized by the system but there is no drive activity.</li> <li>Blink - The LED blinks randomly in response to data being written to or read from the drive.</li> <li>Off - The drive is powered off or the installed drive is not recognized by the system.</li> </ul>

### 1.7.4 Server Node Power Supply Status Indicators

See a listing of the various status indicators for an Oracle Database Appliance Version 1 server node power supply.

There are three status LEDs on each power supply for Oracle Database Appliance Version 1.

The following figure shows the power supply status indicators viewable from the rear of each server node.



Callout	Indicator/LED: Color	State Meaning
1	OK: green	<ul style="list-style-type: none"> <li>On - The power supply is operating normally.</li> <li>Off - The power supply is unplugged or turned off.</li> </ul>
2	Service Required: amber	<ul style="list-style-type: none"> <li>On - The power supply is faulty. The front REAR PS LED and the front and rear panel Service Required LEDs are also lit if the system detects a power supply fault.</li> <li>Off - Normal operation.</li> </ul>
3	AC Present: green	<ul style="list-style-type: none"> <li>On - The power supply is plugged in and AC power is available, regardless of system power state.</li> <li>Off - The power supply is unplugged or turned off.</li> </ul>

## 1.7.5 Server Node Rear Status Indicators

See a listing of the various system status indicators at the rear of an Oracle Database Appliance Version 1 server node.

Each server node in Oracle Database Appliance Version 1 has four summary status LEDs that are located on its back panel.

The following figure shows the status indicators viewable from the rear of each server node.



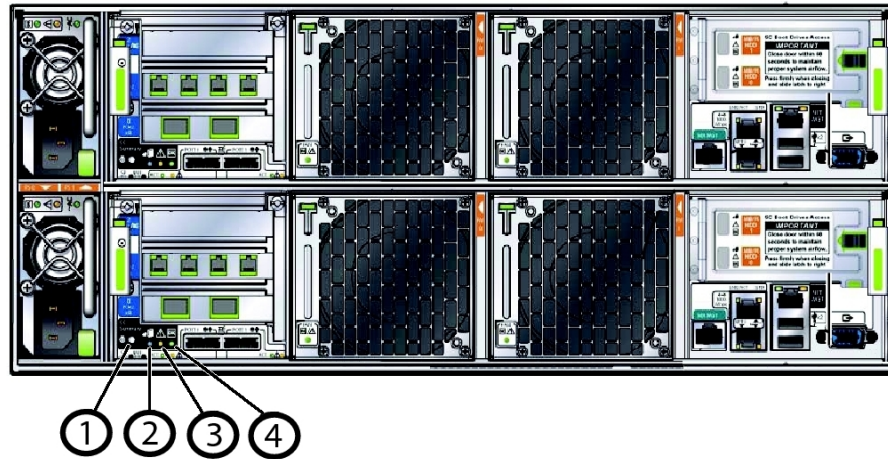

Callout	Indicator/LED: Color	State Meaning
1	Locate: white	<ul style="list-style-type: none"> <li>Off - Normal operation.</li> <li>Fast blink - This LED blinks to help locate the system. Operators can turn this indicator on and off remotely using Oracle ILOM.</li> <li>Pressing this button toggles the fast blink on or off.</li> <li>Indicator Test Mode - Push and hold the Locate button for 5 seconds to activate the push to test feature, which causes all LEDs except disk activity and power supply LEDs to light for 15 seconds.</li> </ul>
2	Ready to Remove: blue	<ul style="list-style-type: none"> <li>Off - Normal operation.</li> <li>Fast Blink - The system is preparing a customer-replaceable unit (CRU) (disk drive, fan module, or power supply) for safe removal but it is not ready yet.</li> <li>Steady on - The CRU can be safely removed.</li> </ul>
3	Service Required: amber	<ul style="list-style-type: none"> <li>Off - Normal operation.</li> <li>Steady on - A fault is present in system or a subsystem within the chassis.</li> </ul>



Callout	Indicator/LED: Color	State Meaning
4	Power/OK: green	<p>This LED indicates the operational state of the chassis. This LED can be in the following states:</p> <ul style="list-style-type: none"> <li>Off - AC power is not present or the Oracle ILOM boot has not completed.</li> <li>Standby blink - Standby power is on and Oracle ILOM can be accessed, but full chassis power is off. The LED blinks at a 10 percent duty cycle (0.1 second on, 2.9 seconds off), that is, the light is on for a very short period of time.</li> <li>Slow blink - The startup sequence has been initiated on the host. The LED blinks at a 50 percent duty cycle, which is noticeably longer than the STANDBY BLINK. This pattern should begin immediately following powering on the system. This status indicates either 1) power-on self-test (POST) diagnostics running on system host or 2) the host is transitioning from the powered-on state to the standby state on shutdown.</li> <li>Steady on - The system is powered on and all host POST tests passed. The system is one of the following states: 1) the system host is ready to boot, or 2) the system host is booting the operating system (OS), or 3) the system host is running the OS.</li> </ul>

## 1.7.6 Server Node Internal LEDs

See a listing of the various internal status indicators (LEDs) for an Oracle Database Appliance Version 1 server node.

The following section describes the internal LEDs for Oracle Database Appliance Version 1. Each server node contains the following internal LEDs:

### Note:

A super capacitor (located on the motherboard) provides power to light the server node fault LEDs for up to 15 minutes after the server node is removed from a powered-on system chassis. After approximately 15 minutes, the capacitor discharges enough so that it cannot light the fault LEDs.

- Fault Remind Power Good LED.

This green LED lights each time the Fault Remind button is pressed, if the capacitor has enough of a charge to light the fault LEDs. This LED is located next to the Fault Remind button.

For the location of Fault Remind button and the Fault Remind Power Good LED, see [Remove Faulty DIMMs](#) (page A-32).

- Memory DIMM Fault LEDs

Each DIMM slot has an adjacent DIMM fault LED. If a DIMM fails, the adjacent LED lights when the Fault Remind button is pressed.

For the location of Fault Remind button and the DIMM fault LEDs, see [Remove Faulty DIMMs](#) (page A-32).

- CPU Fault LEDs

Both CPUs have an associated CPU fault LED. If a CPU fails, the associated LED lights when the Fault Remind button is pressed.

For the location of CPU fault LEDs, see [Remove Processor \(CPU\)](#) (page A-56).

## 1.7.7 Server Node Ethernet Port Status Indicators

See a listing of the various Ethernet port status indicators at the rear of an Oracle Database Appliance Version 1 server node.

Each server node in Oracle Database Appliance Version 1 has two host Ethernet ports (NET0 and NET1) and an SP network management port (NET MGT). Each of these has two LEDs that indicate link activity and port speed.

The following figure shows the status indicators viewable from the rear of each server node.

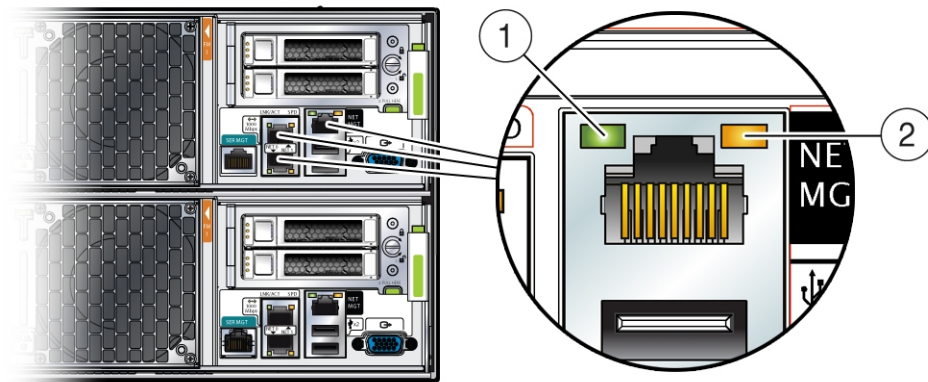

Callout	Indicator/LED: Color	State Meaning
1	Link Activity: green	Lights to indicate link activity.
2	Link Speed: bi-colored	Green - Link established at fastest speed. Amber - Link established at next fastest speed or slower speeds. Off - Link at slowest speed, which is 10 Mbps.

# 2

## Preparing Oracle Database Appliance for Service

How to prepare the Oracle Database Appliance for servicing.

- [Preparing Oracle Database Appliance X7-2 Series for Service](#) (page 2-1)  
This section describes how to prepare an Oracle Database Appliance X7 series system for service.
- [Preparing Oracle Database Appliance X6-2 Series for Service](#) (page 2-2)  
This section describes how to prepare an Oracle Database Appliance X6 series system for service.
- [Preparing Oracle Database Appliance X3-2/X4-2/X5-2 for Service](#) (page 2-3)  
This section describes how to prepare an Oracle Database Appliance X3-2/X4-2/X5-2 system for service.
- [Preparing Oracle Database Appliance Version 1 for Service](#) (page 2-4)  
This section describes how to prepare an Oracle Database Appliance Version 1 system for service.

### 2.1 Preparing Oracle Database Appliance X7-2 Series for Service

This section describes how to prepare an Oracle Database Appliance X7 series system for service.

If you have Oracle Database X6-2 series, go to [Preparing Oracle Database Appliance X6-2 Series for Service](#) (page 2-2). If you have Oracle Database X3-2/X4-2/X5-2, go to [Preparing Oracle Database Appliance X3-2/X4-2/X5-2 for Service](#) (page 2-3). If you have Oracle Database Appliance Version 1, go to [Preparing Oracle Database Appliance Version 1 for Service](#) (page 2-4).

Most service procedures are performed on a single appliance component. Service procedures that require a single server node to be powered off can be performed without shutting down the entire appliance. Before powering off any component for service, refer to the *Deployment and User's Guide* for the Oracle Database Appliance X7 series for any special instructions or commands that must be performed on the appliance to prepare it for service.

#### Note:

The links in the following table take you to instructions **outside** of the Oracle Database Appliance library to the Oracle Server X7-2 documentation library. Use your browser's Back button to return to the Oracle Database Appliance library.

Oracle Database Appliance X7-2S/X7-2M	Oracle Database Appliance X7-2-HA
<a href="#">Safety Precautions</a>	<a href="#">Safety Precautions</a>
<a href="#">Safety Symbols</a>	<a href="#">Safety Symbols</a>
<a href="#">Electrostatic Discharge Safety</a>	<a href="#">Electrostatic Discharge Safety</a>
<a href="#">Required Tools</a>	<a href="#">Required Tools</a>
<a href="#">Powering Down the Server</a>	<a href="#">Powering Down the Server</a>
<a href="#">Disconnect Cables From the Server</a>	<a href="#">Disconnect Cables From the Server</a>
<a href="#">Extend the Server to the Maintenance Position</a>	<a href="#">Extend the Server to the Maintenance Position</a>
<a href="#">Remove the Server From the Rack</a>	<a href="#">Remove the Server From the Rack</a>
<a href="#">Take Antistatic Measures</a>	<a href="#">Take Antistatic Measures</a>
<a href="#">Remove the Server Top Cover</a>	<a href="#">Remove the Server Top Cover</a>

## 2.2 Preparing Oracle Database Appliance X6-2 Series for Service

This section describes how to prepare an Oracle Database Appliance X6 series system for service.

If you have Oracle Database X7-2 series, go to [Preparing Oracle Database Appliance X7-2 Series for Service](#) (page 2-1). If you have Oracle Database X3-2/X4-2/X5-2, go to [Preparing Oracle Database Appliance X3-2/X4-2/X5-2 for Service](#) (page 2-3). If you have Oracle Database Appliance Version 1, go to [Preparing Oracle Database Appliance Version 1 for Service](#) (page 2-4).

Most service procedures are performed on a single appliance component. Service procedures that require a single server node to be powered off can be performed without shutting down the entire appliance. Before powering off any component for service, refer to the *Deployment and User's Guide* for the Oracle Database Appliance X6 series for any special instructions or commands that must be performed on the appliance to prepare it for service.

### Note:

The links in the following table take you to instructions **outside** of the Oracle Database Appliance library to the Oracle Server X6-2 and Oracle Server X6-2L (including Storage Server X6-2 Extreme Flash version) documentation libraries. Use your browser's Back button to return to the Oracle Database Appliance library.

Oracle Database Appliance X6-2S/X6-2M	Oracle Database Appliance X6-2L	Oracle Database Appliance X6-2-HA
<a href="#">Safety Precautions</a>	<a href="#">Safety Precautions</a>	<a href="#">Safety Precautions</a>
<a href="#">Safety Symbols</a>	<a href="#">Safety Symbols</a>	<a href="#">Safety Symbols</a>
<a href="#">Electrostatic Discharge Safety</a>	<a href="#">Electrostatic Discharge Safety</a>	<a href="#">Electrostatic Discharge Safety</a>

Oracle Database Appliance X6-2S/X6-2M	Oracle Database Appliance X6-2L	Oracle Database Appliance X6-2-HA
<a href="#">Required Tools</a>	<a href="#">Required Tools</a>	<a href="#">Required Tools</a>
<a href="#">Powering Down the Server</a>	<a href="#">Powering Down the Server</a>	<a href="#">Powering Down the Server</a>
<a href="#">Disconnect Cables From the Server</a>	<a href="#">Disconnect Cables From the Server</a>	<a href="#">Disconnect Cables From the Server</a>
<a href="#">Extend the Server to the Maintenance Position</a>	<a href="#">Extend the Server to the Maintenance Position</a>	<a href="#">Extend the Server to the Maintenance Position</a>
<a href="#">Remove the Server From the Rack</a>	<a href="#">Remove the Server From the Rack</a>	<a href="#">Remove the Server From the Rack</a>
<a href="#">Take Antistatic Measures</a>	<a href="#">Take Antistatic Measures</a>	<a href="#">Take Antistatic Measures</a>
<a href="#">Remove the Server Top Cover</a>	<a href="#">Remove the Server Top Cover</a> <a href="#">Remove the Server Fan Assembly Door</a>	<a href="#">Remove the Server Top Cover</a>

## 2.3 Preparing Oracle Database Appliance X3-2/X4-2/X5-2 for Service

This section describes how to prepare an Oracle Database Appliance X3-2/X4-2/X5-2 system for service.

If you have Oracle Database X7-2 series, go to [Preparing Oracle Database Appliance X7-2 Series for Service](#) (page 2-1). If you have Oracle Database X6-2 series, go to [Preparing Oracle Database Appliance X6-2 Series for Service](#) (page 2-2). If you have Oracle Database Appliance Version 1, go to [Preparing Oracle Database Appliance Version 1 for Service](#) (page 2-4).

Most service procedures are performed on a single appliance component. Service procedures that require a single server node to be powered off can be performed without shutting down the entire appliance. Before powering off any component for service, refer to the *Getting Started Guide* or the *Administration and Reference Guide* for any special instructions or commands that must be performed on the appliance to prepare it for service.

 **Note:**

The links in the following table take you to instructions **outside** of the Oracle Database Appliance library to the Sun Server X3-2, Sun Server X4-2, and Oracle Server X5-2 documentation libraries. Use your browser's Back button to return to the Oracle Database Appliance library.

Oracle Database Appliance X3-2	Oracle Database Appliance X4-2	Oracle Database Appliance X5-2
<a href="#">Safety Precautions</a>	<a href="#">Safety Precautions</a>	<a href="#">Safety Precautions</a>
<a href="#">Safety Symbols</a>	<a href="#">Safety Symbols</a>	<a href="#">Safety Symbols</a>
<a href="#">Electrostatic Discharge Safety</a>	<a href="#">Electrostatic Discharge Safety</a>	<a href="#">Electrostatic Discharge Safety</a>

Oracle Database Appliance X3-2	Oracle Database Appliance X4-2	Oracle Database Appliance X5-2
<a href="#">Required Tools</a>	<a href="#">Required Tools</a>	<a href="#">Required Tools</a>
<a href="#">Powering Down the Server</a>	<a href="#">Powering Down the Server</a>	<a href="#">Powering Down the Server</a>
<a href="#">Disconnect Cables From the Server</a>	<a href="#">Disconnect Cables From the Server</a>	<a href="#">Disconnect Cables From the Server</a>
<a href="#">Extend the Server to the Maintenance Position</a>	<a href="#">Extend the Server to the Maintenance Position</a>	<a href="#">Extend the Server to the Maintenance Position</a>
<a href="#">Remove the Server From the Rack</a>	<a href="#">Remove the Server From the Rack</a>	<a href="#">Remove the Server From the Rack</a>
<a href="#">Take Antistatic Measures</a>	<a href="#">Take Antistatic Measures</a>	<a href="#">Take Antistatic Measures</a>
<a href="#">Remove the Server Top Cover</a>	<a href="#">Remove the Server Top Cover</a>	<a href="#">Remove the Server Top Cover</a>

## 2.4 Preparing Oracle Database Appliance Version 1 for Service

This section describes how to prepare an Oracle Database Appliance Version 1 system for service.

If you have Oracle Database X7-2 series, go to [Preparing Oracle Database Appliance X7-2 Series for Service](#) (page 2-1). If you have Oracle Database X6-2 series, go to [Preparing Oracle Database Appliance X6-2 Series for Service](#) (page 2-2). If you have Oracle Database Appliance X3-2/X4-2/X5-2, go to [Preparing Oracle Database Appliance X3-2/X4-2/X5-2 for Service](#) (page 2-3).

- [Component Replacement Policy \(CRUs and FRUs\)](#) (page A-2)
- [Safety Information](#) (page A-4)
- [Required Tools](#) (page A-4)
- [Obtaining the Chassis Serial Number](#) (page A-5)
- [Shutting Down a Server Node and Powering Off the System](#) (page A-5)
- [Performing Electrostatic Discharge and Antistatic Prevention Measures](#) (page A-8)
- [Removing Server Nodes From the System Chassis](#) (page A-9)
- [Removing the Server Node Top Cover](#) (page A-11)
- [Removing the Middle Section of the System Top Cover](#) (page A-12)

# 3

## Servicing CRUs That Do Not Require System Power Off

Perform tasks for servicing hot plug components in the Oracle Database Appliance.

Hot-pluggable components can be replaced with the system powered on.

### Note:

Hot-pluggable components can also be replaced with the system powered off. If you choose this method, first power off the system as described in [Preparing Oracle Database Appliance for Service](#) (page 2-1).

- [Oracle Database Appliance X7-2 Series Server Node Hot-Pluggable Components](#) (page 3-1)  
This section describes how to perform hot plug tasks on an Oracle Database Appliance X7-2 series server.
- [Oracle Database Appliance X6-2 Series Server Node Hot-Pluggable Components](#) (page 3-6)  
This section describes how to perform hot plug tasks on an Oracle Database Appliance X6-2 series server.
- [Oracle Database Appliance X3-2/X4-2/X5-2 Series Server Node Hot-Pluggable Components](#) (page 3-12)  
This section describes how to perform hot plug tasks on an Oracle Database Appliance X3-2/X4-2/X5-2 series server.
- [Oracle Database Appliance X3-2/X4-2/X5-2 and X6-2-HA/X7-2-HA Storage Shelf Hot-Pluggable Components](#) (page 3-13)  
Perform hot plug tasks on an Oracle Database Appliance storage shelf.
- [Oracle Database Appliance Version 1 Hot-Pluggable Components](#) (page 3-31)  
This section describes how to perform hot plug tasks on an Oracle Database Appliance Version 1 system.

### 3.1 Oracle Database Appliance X7-2 Series Server Node Hot-Pluggable Components

This section describes how to perform hot plug tasks on an Oracle Database Appliance X7-2 series server.

If you have Oracle Database Appliance X6-2 series, go to [Oracle Database Appliance X6-2 Series Server Node Hot-Pluggable Components](#) (page 3-6). If you have the Oracle Database Appliance X3-2/X4-2/X5-2, go to [Oracle Database Appliance X3-2/X4-2/X5-2 Server Node Hot-Pluggable Components](#) (page 3-12). If you have Oracle

Database Appliance Version 1, go to [Oracle Database Appliance Version 1 Hot-Pluggable Components](#) (page 3-31).

If you are servicing storage shelf hot plug components, see [Oracle Database Appliance X3-2/X4-2/X5-2 and X6-2-HA/X7-2-HA Storage Shelf Hot-Pluggable Components](#) (page 3-13).

Hot-pluggable components are those that can be removed and installed while the system is running. These are designated as Customer Replaceable Units (CRUs).

 **Note:**

After a physical insertion or removal action of a storage component (such as a disk or SAS cable), you should wait before performing the next action to allow the system software to fully process the event. This could take up to 3 minutes to complete.

Refer to the following table for hot-plug component instructions for your appliance.

 **Note:**

Some of the links in the following table take you to instructions *outside* of the Oracle Database Appliance library to the Oracle Server X7-2 documentation library. Use your browser's Back button to return to the Oracle Database Appliance library.

Oracle Database Appliance X7-2S/X7-2M	Oracle Database Appliance X7-2-HA
<a href="#">Servicing NVMe Storage Drives (CRU)</a> (page 3-2) <b>Caution:</b> An NVMe drive must first be powered off before removal. If you do not power off the NVMe drive before removal you can crash the operating system. Oracle Database Appliance uses special commands to remove or add NVMe storage.	Front mounted storage drives are not supported in the server nodes for this product.
<a href="#">Servicing Fan Modules (CRU)</a>	<a href="#">Servicing Fan Modules (CRU)</a>
<a href="#">Servicing Power Supplies (CRU)</a>	<a href="#">Servicing Power Supplies (CRU)</a>

- [Servicing NVMe Storage Drives \(CRU\)](#) (page 3-2)  
Perform tasks for servicing NVMe drives in an Oracle Database Appliance X7 series system.

### 3.1.1 Servicing NVMe Storage Drives (CRU)

Perform tasks for servicing NVMe drives in an Oracle Database Appliance X7 series system.

- [Replacing an NVMe Storage Drive](#) (page 3-3)  
Replace an NVMe drive in an Oracle Database Appliance X7 series system.



- [Adding NVMe Expansion Storage](#) (page 3-5)  
Add NVMe storage to an Oracle Database Appliance X7-2M.

### 3.1.1.1 Replacing an NVMe Storage Drive

Replace an NVMe drive in an Oracle Database Appliance X7 series system.

Before removing an NVMe drive it must be powered off. After installing an NVMe drive it must be powered on. Failed drives are automatically powered off after 5 minutes.

#### ▲ Caution:

If you remove an NVMe drive without first powering it off, you can crash the operating system. Oracle Database Appliance uses special commands to add or remove NVMe storage.

The instructions describe how to replace an NVMe drive using the `odaadmcli power on/off` commands for an Oracle Database X7-2 series system.

The `odaadmcli` commands listed here must be run as the root user.

1. Identify the NVMe drive to be replaced. Type the following command at the host:

```
# odaadmcli show disk
```

For example, the drive names `pd_00` and `pd_01` seen by the host correspond to drive slot labels NMe0 and NVMe1, respectively.

2. Unmount and power off the drive to be replaced. Do one of the following:
  - a. If you are replacing a failed drive, check to see if its blue ready-to-remove light is lit.  
  
If a drive has failed, it should power off automatically and light its blue ready-to-remove indicator after 5 minutes.
  - b. If the drive being replaced doesn't already have its blue ready-to-remove indicator lit, type the following command from the host to unmount and turn off power to the drive:

```
# odaadmcli power disk off pd_xx
```

Where `pd_xx` is the name of the disk to be replaced as described in step 1.

Before proceeding to the next step confirm that the blue ready-to-remove indicator on the drive is lit.

3. Push the latch release button on the front of the drive to open the drive latch [1], grasp the latch, and pull the drive out of the drive slot [2] as shown in the following figure.

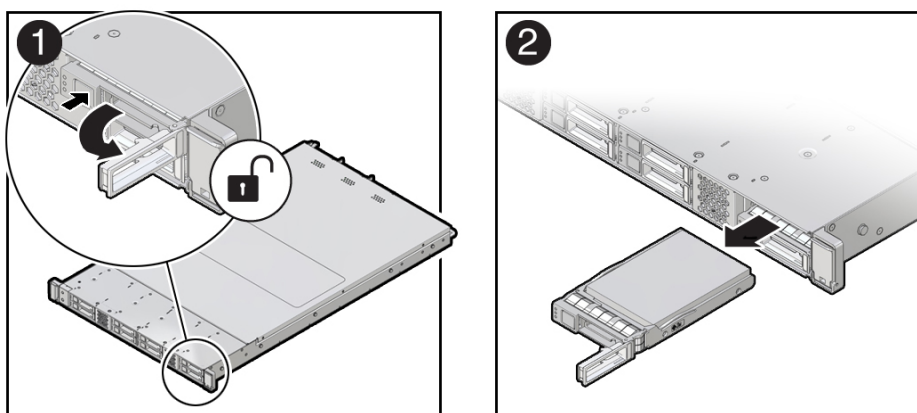

4. Align the replacement drive with the drive slot.

The drive is physically addressed according to the slot in which it is installed. It is important to install a replacement drive in the same slot as the drive that was removed.

5. Slide the drive into the slot until the drive is fully seated [1] and then close the drive latch to lock the drive in place [2] as shown in the following figure.

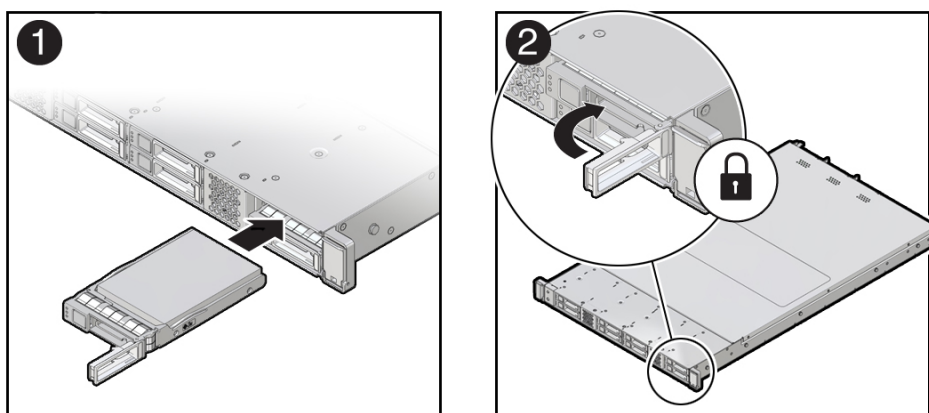

6. Power on and remount the replacement drive. Type the following command from the host:

```
# odaadmcli power disk on pd_xx
```

Where `pd_xx` is the name of the disk being replaced as described in step 1.

It can take a few minutes for the power-on operation to complete. Once complete, the drive's green OK indicator will light.

7. To check the status of the replacement disk, type the following command from the host:

```
# odaadmcli show disk
```

For additional information, refer to the Oracle Database Appliance *Deployment and User's Guide*.

### 3.1.1.2 Adding NVMe Expansion Storage

Add NVMe storage to an Oracle Database Appliance X7-2M.

- The **Oracle Database Appliance X7-2M** supports six expansion slots for NVMe drives. These are slots labeled 2 through 7 as seen from the front of the system (callouts 1 through 6 in the following illustration). Storage drives can be added in sets of three.

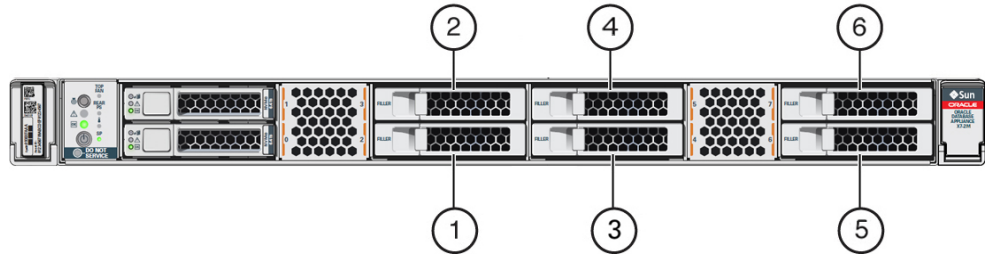

If you have the default configuration of only two NVMe drives (seen as `pd_00` and `pd_01` from the host), you can expand storage by either three (3) or six (6) NVMe drives.

- When expanding storage, populate slots starting with the lowest numbered available slot (for example, slot 2 as seen on the front panel).
  - The drive power-up and storage expansion `odaadmcli` commands listed here should only be run after all new disk drives have been physically installed. Once you expand storage, you cannot revert to a previous storage configuration (for example, the default installation with only two NVMe drives).
  - The `odaadmcli` commands listed here must be run as the root user.
1. Remove the drive filler panel of an unpopulated slot by using your finger to pry open the panel release latch and pulling the filler out of the drive slot.



#### Note:

Replace filler panels with drives one at a time to ensure proper system cooling.

2. Open the latch of the new drive by pressing the release button on the drive.



#### Caution:

Do not over-rotate the latch outwards when opening. Doing so can damage it.

3. Insert the new drive by sliding the drive into the slot until the drive is fully seated. Then close the drive latch to lock the drive in place.

4. Repeat steps 1 - 3 for each new drive.
  - For the **Oracle Database Appliance X7-2M**, the name for these drives to the host will be `pd_02`, `pd_03`, `pd_04`, etc., matching the numbering of their respective drive slots up to `pd_07`.
5. Power on the new drives by entering the appropriate commands from the host.
  - If you are adding three drives, type:
 

```
# odaadmcli power disk on pd_02
# odaadmcli power disk on pd_03
# odaadmcli power disk on pd_04
```
  - If you are adding six drives, additionally type:
 

```
# odaadmcli power disk on pd_05
# odaadmcli power disk on pd_06
# odaadmcli power disk on pd_07
```

It can take a few minutes for the power-on operation to complete. Once complete, the green OK indicators will light for the newly installed drives.

 **Note:**

Do not attempt to power on and expand storage on one new disk and then power on and expand storage on the next new disk. Before you can expand storage, all the new disks must be powered on with their green OK indicators lit.

6. Expand the system storage to include the new drives. Type the following command from the host:
 

```
# odaadmcli expand storage -ndisk number_of_disks
```

Where *number\_of\_disks* is the number of disks being added. The system will then detect and use the new storage.

For additional information, refer to the Oracle Database Appliance *Deployment and User's Guide*.

## 3.2 Oracle Database Appliance X6-2 Series Server Node Hot-Pluggable Components

This section describes how to perform hot plug tasks on an Oracle Database Appliance X6-2 series server.

If you have Oracle Database Appliance X7-2 series, go to [Oracle Database Appliance X7-2 Series Server Node Hot-Pluggable Components](#) (page 3-1). If you have the Oracle Database Appliance X3-2/X4-2/X5-2, go to [Oracle Database Appliance X3-2/X4-2/X5-2 Server Node Hot-Pluggable Components](#) (page 3-12). If you have Oracle Database Appliance Version 1, go to [Oracle Database Appliance Version 1 Hot-Pluggable Components](#) (page 3-31).

If you are servicing storage shelf hot plug components, see [Oracle Database Appliance X3-2/X4-2/X5-2 and X6-2-HA/X7-2-HA Storage Shelf Hot-Pluggable Components](#) (page 3-13).

Hot-pluggable components are those that can be removed and installed while the system is running. These are designated as Customer Replaceable Units (CRUs).

 **Note:**

After a physical insertion or removal action of a storage component (such as a disk or SAS cable), you should wait before performing the next action to allow the system software to fully process the event. This could take up to 3 minutes to complete.

Refer to the following table for hot-plug component instructions for your appliance.

 **Note:**

Some of the links in the following table take you to instructions *outside* of the Oracle Database Appliance library to the Oracle Server X6-2 and Oracle Server X6-2L (including Storage Server X6-2 Extreme Flash version) documentation libraries. Use your browser's Back button to return to the Oracle Database Appliance library.

Oracle Database Appliance X6-2S/X6-2M	Oracle Database Appliance X6-2L	Oracle Database Appliance X6-2-HA
<a href="#">Servicing Non-NVMe Storage Drives (CRU)</a>	<a href="#">Servicing Non-NVMe Storage Drives (CRU)</a>	<a href="#">Servicing Non-NVMe Storage Drives (CRU)</a>
<a href="#">Servicing NVMe Storage Drives (CRU)</a> (page 3-8)	<a href="#">Servicing NVMe Storage Drives (CRU)</a> (page 3-8)	Front mounted storage drives are not supported in the server nodes for this product.
<b>Caution:</b> An NVMe drive must first be powered off before removal. If you do not power off the NVMe drive before removal you can crash the operating system. Oracle Database Appliance uses special commands to remove or add NVMe storage.	<b>Caution:</b> An NVMe drive must first be powered off before removal. If you do not power off the NVMe drive before removal you can crash the operating system. Oracle Database Appliance uses special commands to remove or add NVMe storage.	
<a href="#">Servicing Fan Modules (CRU)</a>	<a href="#">Servicing Fan Modules (CRU)</a>	<a href="#">Servicing Fan Modules (CRU)</a>
<a href="#">Servicing Power Supplies (CRU)</a>	<a href="#">Servicing Power Supplies (CRU)</a>	<a href="#">Servicing Power Supplies (CRU)</a>

- [Servicing NVMe Storage Drives \(CRU\)](#) (page 3-8)  
Perform tasks to service NVMe drives in an Oracle Database Appliance X6 Series system.

## 3.2.1 Servicing NVMe Storage Drives (CRU)

Perform tasks to service NVMe drives in an Oracle Database Appliance X6 Series system.

This section describes servicing NVMe drives in an Oracle Database Appliance X6-2 series system.

- [Replacing an NVMe Storage Drive](#) (page 3-8)  
Replace an NVMe drive in an Oracle Database Appliance X6 series system.
- [Adding NVMe Expansion Storage](#) (page 3-10)  
Add NVMe storage in an Oracle Database Appliance X6 series system.

### 3.2.1.1 Replacing an NVMe Storage Drive

Replace an NVMe drive in an Oracle Database Appliance X6 series system.

Before removing an NVMe drive it must be powered off. After installing an NVMe drive it must be powered on. Failed drives are automatically powered off after 5 minutes.

#### **Caution:**

If you remove an NVMe drive without first powering it off, you can crash the operating system. Oracle Database Appliance uses special commands to add or remove NVMe storage.

The instructions describe how to replace an NVMe drive using the `odaadmcli power on/off` commands for an Oracle Database X6-2 series system.

The `odaadmcli` commands listed here must be run as the root user.

1. Identify the NVMe drive to be replaced. Type the following command at the host:

```
# odaadmcli show disk
```

For example, the drive names `pd_00` and `pd_01` seen by the host correspond to drive slot labels NMe0 and NVMe1, respectively.

2. Unmount and power off the drive to be replaced. Do one of the following:
  - a. If you are replacing a failed drive, check to see if its blue ready-to-remove light is lit.

If a drive has failed, it should power off automatically and light its blue ready-to-remove indicator after 5 minutes.

- b. If the drive being replaced doesn't already have its blue ready-to-remove indicator lit, type the following command from the host to unmount and turn off power to the drive:

```
# odaadmcli power disk off pd_xx
```

Where `pd_xx` is the name of the disk to be replaced as described in step 1.

Before proceeding to the next step confirm that the blue ready-to-remove indicator on the drive is lit.

3. Push the latch release button on the front of the drive to open the drive latch [1], grasp the latch, and pull the drive out of the drive slot [2] as shown in the following figure.

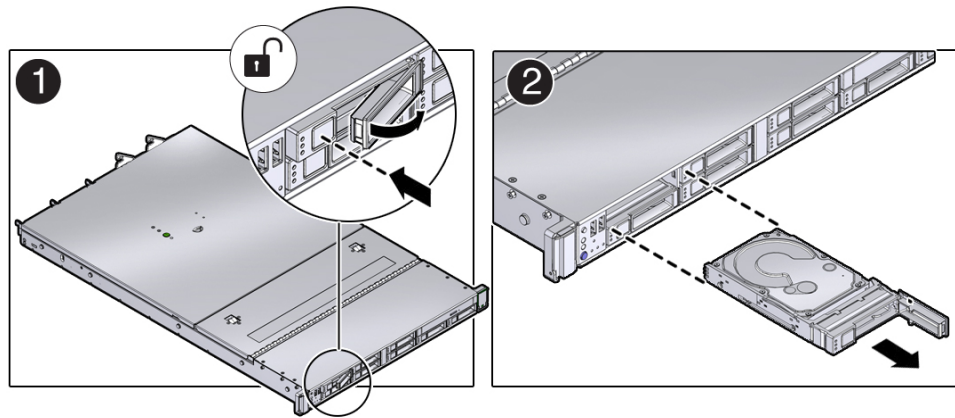

4. Align the replacement drive with the drive slot.  
The drive is physically addressed according to the slot in which it is installed. It is important to install a replacement drive in the same slot as the drive that was removed.
5. Slide the drive into the slot until the drive is fully seated [1] and then close the drive latch to lock the drive in place [2] as shown in the following figure.

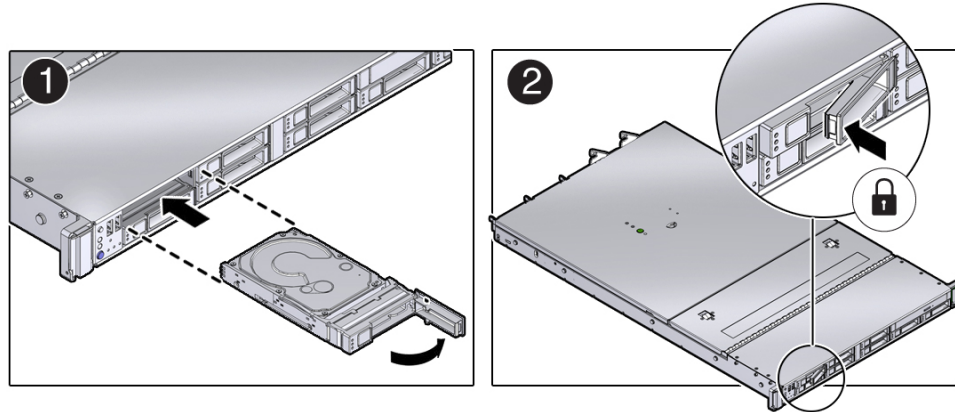

6. Power on and remount the replacement drive. Type the following command from the host:  

```
# odaadmcli power disk on pd_xx
```

Where `pd_xx` is the name of the disk being replaced as described in step 1.  
It can take a few minutes for the power-on operation to complete. Once complete, the drive's green OK indicator will light.
7. To check the status of the replacement disk, type the following command from the host:

```
# odaadmcli show disk
```

For additional information, refer to the Oracle Database Appliance *Deployment and User's Guide*.



### 3.2.1.2 Adding NVMe Expansion Storage

Add NVMe storage in an Oracle Database Appliance X6 series system.

- The **Oracle Database Appliance X6-2S/X6-2M** supports two expansion slots for NVMe drives. These are slots labeled NVMe2 and NVMe3 as seen from the front of the system (callouts 1 and 2 in the following illustration). When adding NVMe storage, you must populate both of these slots.

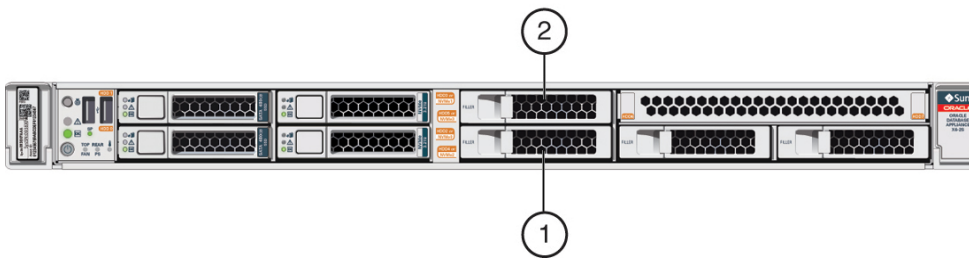

If you have the default configuration of only two NVMe drives (seen as `pd_00` and `pd_01` from the host), you can expand storage by adding two (2) NVMe drives.

- The **Oracle Database Appliance X6-2L** supports three expansion slots for NVMe drives. These are slots labeled NVMe2, NVMe5, and NVMe8 as seen from the front of the system (callouts 1, 2 and 3 in the following illustration). When adding NVMe storage, you must populate all three of these slots.

 **Note:**

Drive slots NVMe9, NVMe10 and NVMe11 are not supported for this product.

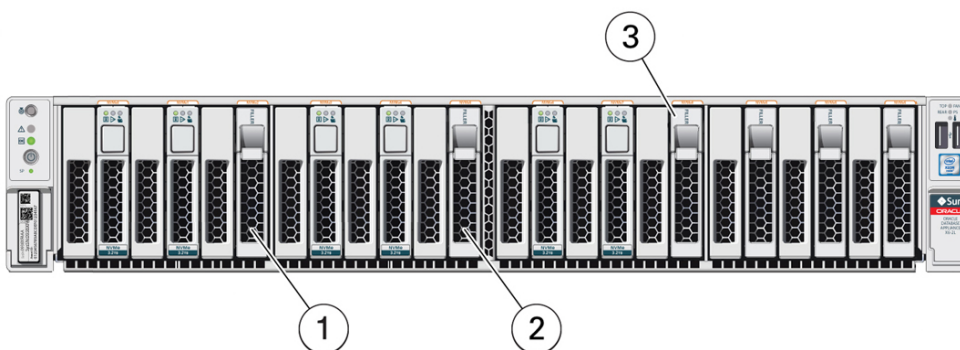

If you have the default configuration of NVMe drives (seen as `pd_00`, `pd_01`, `pd_03`, `pd_04`, `pd_06` and `pd_07` from the host), you can expand storage by adding three (3) NVMe drives.



- The drive power-up and storage expansion `odaadmcli` commands listed here should only be run after all new disk drives have been physically installed. Once you expand storage, you cannot revert to a previous storage configuration (for example, the default factory storage configuration).
  - The `odaadmcli` commands listed here must be run as the root user.
1. Remove the drive filler panel of an unpopulated slot by using your finger to pry open the panel release latch and pulling the filler out of the drive slot.



**Note:**

Replace filler panels with drives one at a time to ensure proper system cooling.

2. Open the latch of the new drive by pressing the release button on the drive.



**Caution:**

Do not over-rotate the latch outwards when opening. Doing so can damage it.

3. Insert the new drive by sliding the drive into the slot until the drive is fully seated. Then close the drive latch to lock the drive in place.
4. Repeat steps 1 - 3 for each new drive.
  - For the **Oracle Database Appliance X6-2S/X6-2M**, the name for these drives to the host will be `pd_02` and `pd_03`, matching the numbering of their respective drive slots.
  - For the **Oracle Database Appliance X6-2L**, the name for these drives to the host will be `pd_02`, `pd_05` and `pd_08`, matching the numbering of their respective drive slots.
5. Power on the new drives by entering the appropriate commands from the host.
  - For the **Oracle Database Appliance X6-2S/X6-2M**, type:
 

```
# odaadmcli power disk on pd_02
# odaadmcli power disk on pd_03
```
  - For the **Oracle Database Appliance X6-2L**, type:
 

```
# odaadmcli power disk on pd_02
# odaadmcli power disk on pd_05
# odaadmcli power disk on pd_08
```

It can take a few minutes for the power-on operation to complete. Once complete, the green OK indicators will light for the newly installed drives.

 **Note:**

Do not attempt to power on and expand storage on one new disk and then power on and expand storage on the next new disk. Before you can expand storage, all the new disks must be powered on with their green OK indicators lit.

6. Expand the system storage to include the new drives. Type the following command from the host:

```
# odaadmcli expand storage
```

The system will then detect and use the new storage.

For additional information, refer to the Oracle Database Appliance *Deployment and User's Guide*.

## 3.3 Oracle Database Appliance X3-2/X4-2/X5-2 Series Server Node Hot-Pluggable Components

This section describes how to perform hot plug tasks on an Oracle Database Appliance X3-2/X4-2/X5-2 series server.

If you have Oracle Database Appliance X7-2 series, go to [Oracle Database Appliance X7-2 Series Server Node Hot-Pluggable Components](#) (page 3-1). If you have Oracle Database Appliance X6-2 series, go to [Oracle Database Appliance X6-2 Series Server Node Hot-Pluggable Components](#) (page 3-6). If you have Oracle Database Appliance Version 1, go to [Oracle Database Appliance Version 1 Hot-Pluggable Components](#) (page 3-31).

If you are servicing storage shelf hot plug components, see [Oracle Database Appliance X3-2/X4-2/X5-2 and X6-2-HA/X7-2-HA Storage Shelf Hot-Pluggable Components](#) (page 3-13).

Hot-pluggable components are those that can be removed and installed while the system is running. These are designated as Customer Replaceable Units (CRUs).

 **Note:**

After a physical insertion or removal action of a storage component (such as a disk or SAS cable), you should wait before performing the next action to allow the system software to fully process the event. This could take up to 3 minutes to complete.

Refer to the following table for hot-plug component instructions for your appliance.

 **Note:**

The links in the following table take you to instructions *outside* of the Oracle Database Appliance library to the Sun Server X3-2, Sun Server X4-2, and Oracle Server X5-2 documentation libraries. Use your browser's Back button to return to the Oracle Database Appliance library.

Oracle Database Appliance X3-2	Oracle Database Appliance X4-2	Oracle Database Appliance X5-2
<a href="#">Servicing Storage Drives (CRU)</a> Note that for bare metal installations of this appliance, you must run the <code>oakcli add disk -local</code> command after replacing a failed disk in a server node. Refer to the <i>Administration and Reference Guide</i> for details.	<a href="#">Servicing Storage Drives (CRU)</a> Note that for bare metal installations of this appliance, you must run the <code>oakcli add disk -local</code> command after replacing a failed disk in a server node. Refer to the <i>Administration and Reference Guide</i> for details.	<a href="#">Servicing Storage Drives (CRU)</a>
<a href="#">Servicing Fan Modules (CRU)</a>	<a href="#">Servicing Fan Modules (CRU)</a>	<a href="#">Servicing Fan Modules (CRU)</a>
<a href="#">Servicing Power Supplies (CRU)</a>	<a href="#">Servicing Power Supplies (CRU)</a>	<a href="#">Servicing Power Supplies (CRU)</a>

## 3.4 Oracle Database Appliance X3-2/X4-2/X5-2 and X6-2-HA/X7-2-HA Storage Shelf Hot-Pluggable Components

Perform hot plug tasks on an Oracle Database Appliance storage shelf.

This section describes replacing hot-pluggable components for the Oracle Database Appliance storage shelf. Only certain versions of Oracle Database Appliance support a storage shelf. If you have Oracle Database Appliance Version 1, go to [Oracle Database Appliance Version 1 Hot-Pluggable Components](#) (page 3-31).

 **Note:**

In certain storage expansion scenarios (explained in the following procedures), adding optional storage might require that the appliance be powered off.

A storage shelf, or expansion storage shelf, are only supported with the following Oracle Database Appliance products:

- Oracle Database Appliance X7-2-HA supports the DE3-24C shelf.
- Oracle Database Appliance X6-2-HA supports the DE3-24C shelf.
- Oracle Database Appliance X5-2 supports the DE2-24C shelf.

- Oracle Database Appliance X3-2 and Oracle Database Appliance X4-2 support the DE2-24P shelf.

Hot-pluggable components are those that can be removed and installed while the system is running. These are designated as Customer Replaceable Units (CRUs).

 **Caution:**

**Data loss.** Do not remove power from both power supplies of the storage shelf or storage expansion shelf (if equipped) while any databases are running. If you must power off the storage shelf or expansion storage shelf, stop the database first.

 **Note:**

After a physical insertion or removal action of a storage component (such as a disk or SAS cable), you should wait before performing the next action to allow the system software to fully process the event. This could take up to 3 minutes to complete.

- [Servicing Storage Shelf Components](#) (page 3-14)  
Perform hot plug tasks on an Oracle Database Appliance storage shelf.

## 3.4.1 Servicing Storage Shelf Components

Perform hot plug tasks on an Oracle Database Appliance storage shelf.

Oracle Database Appliance X7-2-HA (DE3-24C), Oracle Database Appliance X6-2-HA (DE3-24C), Oracle Database Appliance X5-2 (DE2-24C) and Oracle Database Appliance X3-2/X4-2 (DE2-24P) storage shelf components can all be replaced while the storage shelf is powered-on and running. They include:

- [Adding Optional Oracle Database Appliance X7-2-HA Storage Shelf Drives \(CRU\)](#) (page 3-15)  
Add disk storage in an Oracle Database Appliance X7-2-HA storage shelf.
- [Adding Optional Oracle Database Appliance X6-2-HA Storage Shelf Drives \(CRU\)](#) (page 3-19)  
Add disk storage in an Oracle Database Appliance X6-2-HA storage shelf.
- [Replace a Storage Shelf HDD or SSD \(CRU\)](#) (page 3-21)  
Replace a storage disk in an Oracle Database Appliance storage shelf.
- [Replace a Storage Shelf Power Supply \(CRU\)](#) (page 3-24)  
Replace a power supply in an Oracle Database Appliance storage shelf.

### 3.4.1.1 Adding Optional Oracle Database Appliance X7-2-HA Storage Shelf Drives (CRU)

Add disk storage in an Oracle Database Appliance X7-2-HA storage shelf.

- The **Oracle Database Appliance X7-2-HA storage shelf** partially-populated base configuration supports 15 expansion slots for either 3.2 TB SSDs (available in five-packs) or 10 TB HDDs (available in a fifteen-pack). These expansion slots are labeled 5-19 as seen from the front of the system (callouts 5 through 19 in the following illustration).

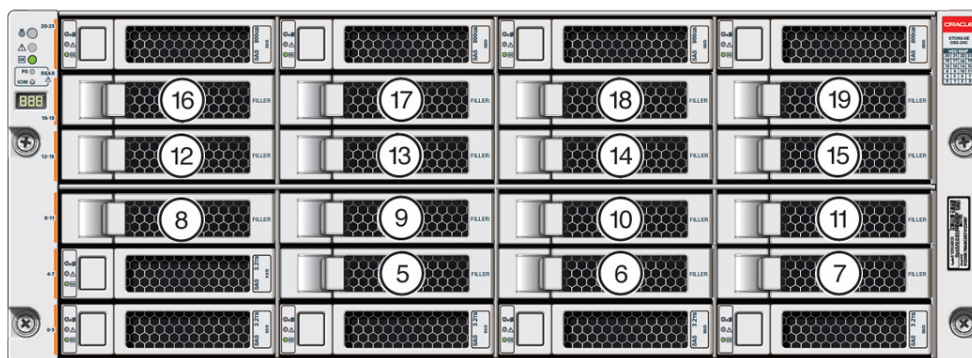

Note the following:

- **Expanding the base configuration storage shelf with 3.2 TB SSDs** can be performed with the appliance running. The base configuration has slots 20-23 populated with 800GB drives for REDO and slots 0-4 with 3.2 TB drives for DATA/RECO. Expansion drives are available in five-packs and are populated in shelf storage slots from the bottom up to be used for DATA/RECO, as follows:
  - \* The first five expansion drives go into slots 5-9.
  - \* The second five expansion drives go into slots 10-14.
  - \* The third five expansion drives go into slots 15-19.

The following illustration shows the expanded drive configuration for 3.2 TB SSDs.

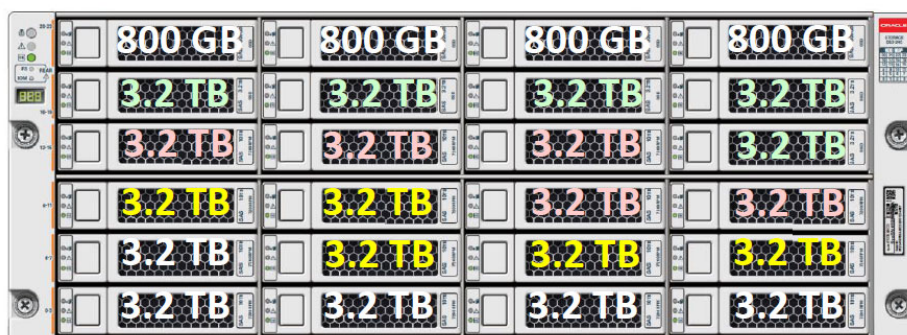

When you expand storage, you must first install all of your expansion disks (5, 10 or 15). Once you expand storage to support additional disks, you cannot revert to the base configuration (no drives in slots 5-19).

- **Expanding the base configuration storage shelf with 10 TB HDDs** requires that you first *power down the appliance*. The base configuration has slots 20-23 populated with 800GB drives for REDO and slots 0-4 with 3.2 TB drives for DATA/RECO. Expansion drives are available in a fifteen-pack and are populated in the storage shelf as follows:
  - \* Move the 3.2 TB DATA/RECO drives from shelf storage slots 0-4 to slots 15-19. These will be used for FLASH after redeployment.
  - \* Install the fifteen 10 TB HDD expansion drives into slots 0-14. These will be used for DATA/RECO after redeployment.

The following illustration shows the expanded drive configuration for 10 TB HDDs.

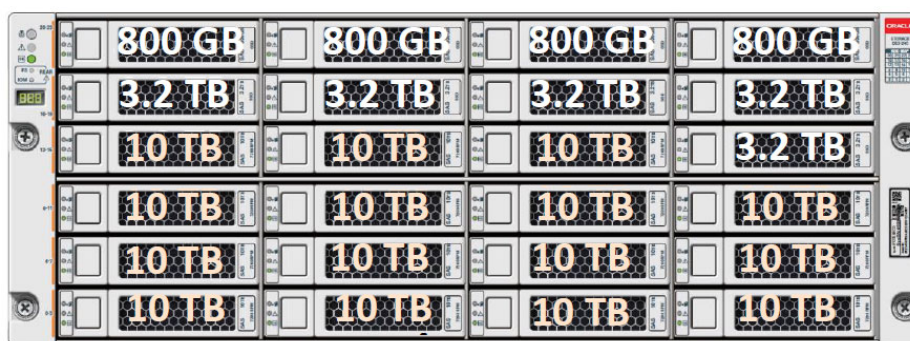

After adding the storage, power on the appliance to perform cleanup, redeploy the appliance and restore the database as described in the *Deployment and User's Guide* for the appliance. Once you expand storage to support additional disks, you cannot revert to the base configuration (no drives in slots 5-19).

- If you plan on adding another storage shelf, it must be populated identically to your first storage shelf.
  - The `odaadmcli` commands listed here must be run as the root user.
1. Do one of the following:
    - If you are adding 3.2 TB SSDs to the storage shelf, leave the appliance powered on and proceed to the next step.
    - If you are adding 10 TB HDDs to the storage shelf, power off the appliance and move the 3.2 TB DATA/RECO drives from shelf storage slots 0-4 to slots 15-19. Proceed to the next step and note that drive removal is similar to filler panel removal (using the release button on the front of the drive).
  2. To install the new drives into the storage shelf, do the following:
    - a. Remove one of the empty slot drive filler panels by pressing its release button [1] and removing it from the drive slot [2] as shown in the following figure.



 **Note:**

Replace filler panels with drives one at a time to ensure proper storage shelf chassis cooling.

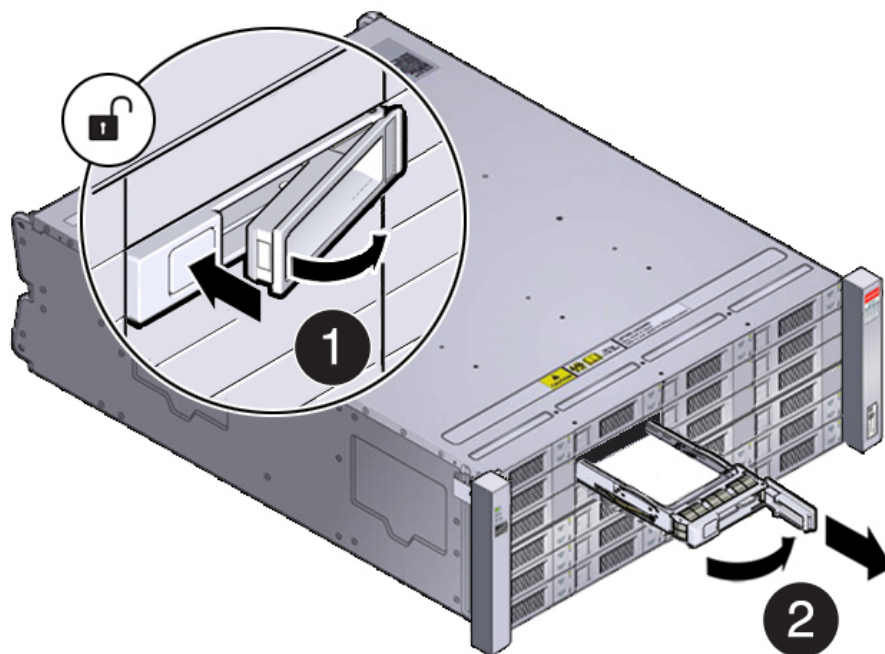

- b. Open the drive lever of the new drive by pressing the release button on the drive.
- c. Slide the new drive into the drive slot [1] until it engages with the backplane connector and then close the lever to fully seat the drive and lock it into place [2] as shown in the following figure.

Check that the drive is locked in place and flush with the other drives.

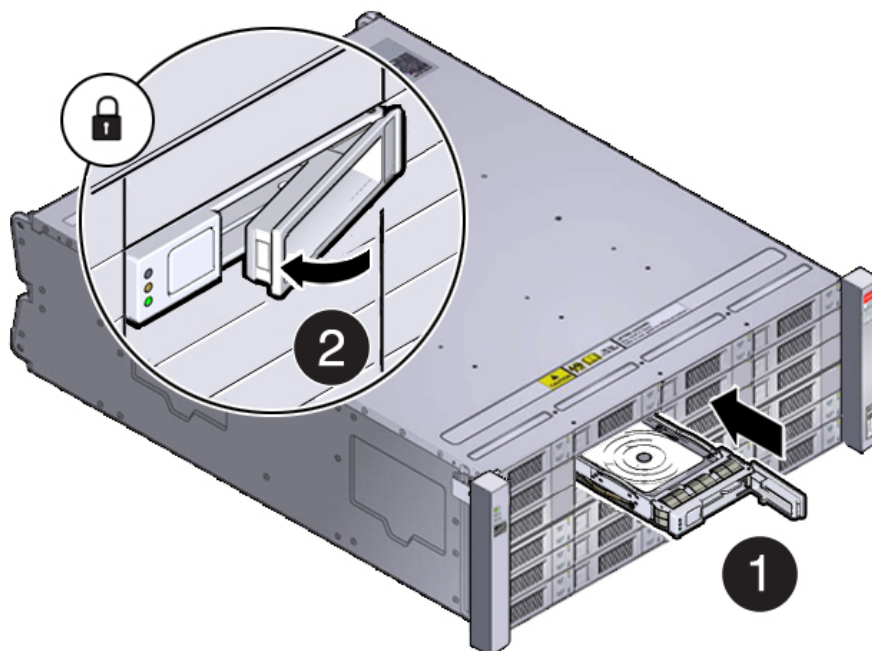

- d. Repeat steps a through c until all of the new drives are installed in the storage shelf.
3. Do one of the following:
  - If you added 3.2 TB SSDs to the shelf, check that the OK indicator on each new drive is steady green to indicate that it is ready. Then expand the system storage to include the new drives by typing the following command from the host:
 

```
# odaadmcli expand storage -ndisk number_of_disks - enclosure 0
```

Where *number\_of\_disks* is the number of disks being added. The system will then detect and use the new storage.
  - If you added 10 TB HDDs to the shelf (and moved the existing 3.2 TB SSDs), power on the appliance and perform cleanup, redeploy the appliance and restore the database as described in the *Deployment and User's Guide* for the appliance.
4. If you are also adding a storage expansion shelf (can only be added to a system with an identically and fully populated storage shelf), you can do so after successfully completing the previous step.

Refer to the Oracle Database Appliance *Owner's Guide* for information on installing a storage expansion shelf into a rack.

Refer to the Oracle Database Appliance *Deployment and User's Guide* for information on cabling and storage expansion commands for a storage expansion shelf.



### 3.4.1.2 Adding Optional Oracle Database Appliance X6-2-HA Storage Shelf Drives (CRU)

Add disk storage in an Oracle Database Appliance X6-2-HA storage shelf.

- The **Oracle Database Appliance X6-2-HA storage shelf** base configuration (half-populated) supports ten expansion slots for 1.6 TB SSD drives. These are slots labeled 10-19 as seen from the front of the system (callouts 10 through 19 in the following illustration). When adding to the storage shelf, you must populate all of these slots at the same time. This upgrade can be performed with the appliance running.

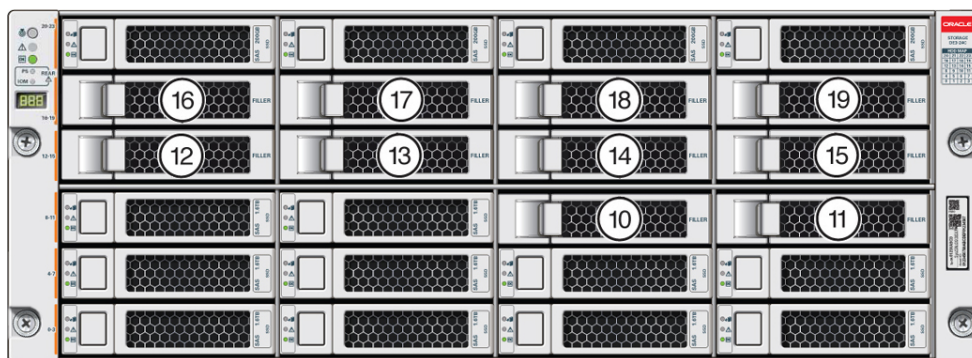

#### Note:

If you expand storage, you must first add all of the disks and then expand storage on all the new disks at the same time. Once you expand storage to support disks in slots 10-19, you cannot revert to the base configuration (no drives in slots 10-19).

- You **cannot** add a storage expansion shelf to your appliance configuration until you have fully populated the existing storage shelf.
  - The `oakcli` commands listed here must be run as the root user.
1. To install the new drives into the storage shelf, do the following:
    - a. Remove one of the drive filler panels from slots 10-19 by pressing its release button [1] and removing it from the drive slot [2] as shown in the following figure.

#### Note:

Replace filler panels with drives one at a time to ensure proper storage shelf chassis cooling.

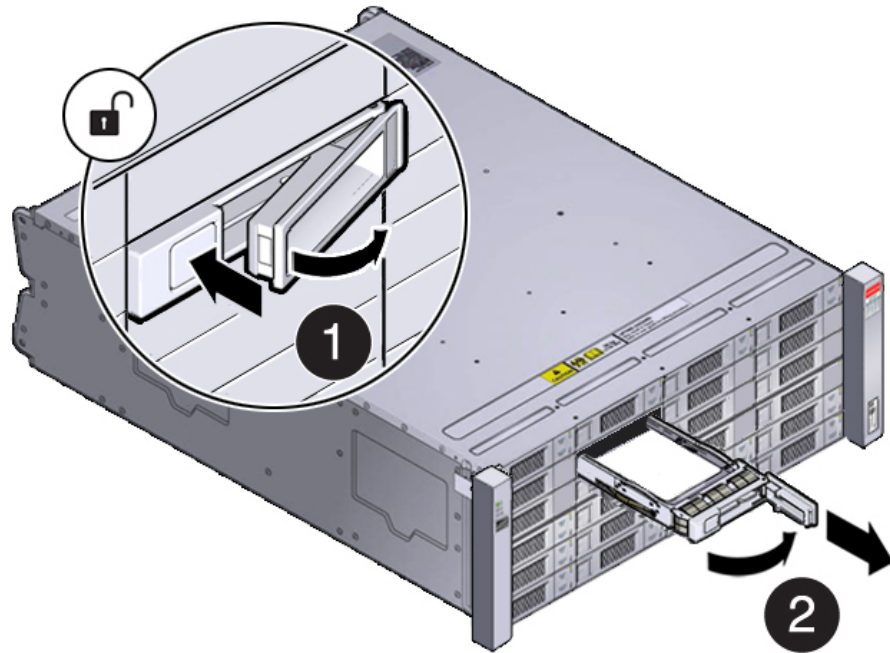

- b. Open the drive lever of the new drive by pressing the release button on the drive.
- c. Slide the new drive into the drive slot [1] until it engages with the backplane connector and then close the lever to fully seat the drive and lock it into place [2] as shown in the following figure.

Check that the drive is locked in place and flush with the other drives.

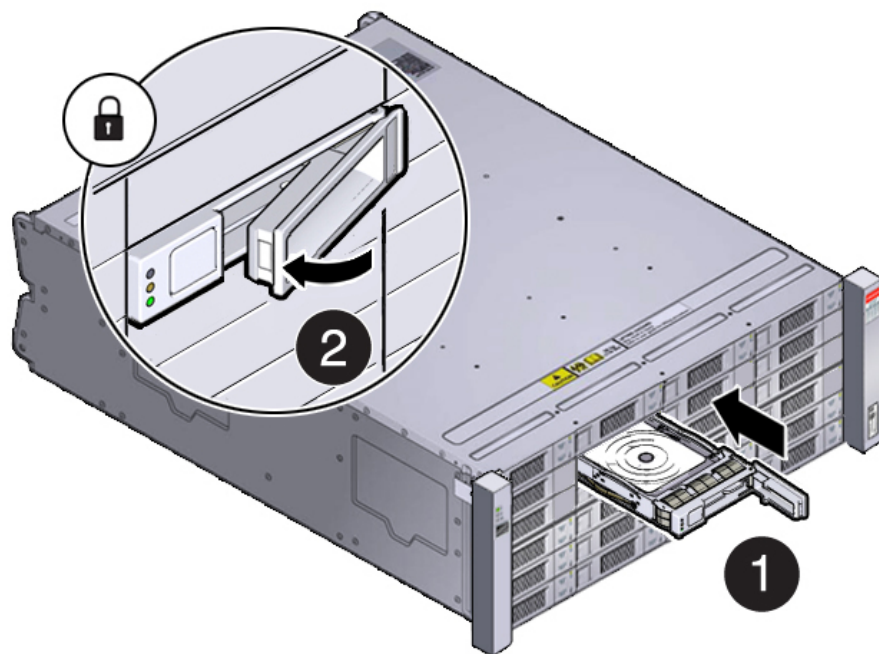

- d. Repeat steps a through c until all of the empty drive slots in the storage shelf are filled with the new drives.

 **Note:**

Before attempting to use the expanded storage, ensure the OK indicator on each new drive is steady green to indicate a ready state.

2. Expand the system storage to include the new drives on the master server node. Type the following command:

```
# oakcli expand storage
```

The system will then detect and use the new storage. After 30 seconds, proceed to the next step.

3. Expand the system storage to include the new drives on the slave server node. Type the following command:

```
# oakcli expand storage
```

The system will then detect and use the new storage.

 **Note:**

It can take up to 12 minutes to add the new storage to the configuration.

4. If you are also adding a storage expansion shelf (can only be added to a system with an identically and fully populated storage shelf), you can do so after successfully completing the previous step.

Refer to the Oracle Database Appliance *Owner's Guide* for information on installing a storage expansion shelf into a rack.

Refer to the Oracle Database Appliance *Deployment and User's Guide* for information on cabling and storage expansion commands for a storage expansion shelf.

### 3.4.1.3 Replace a Storage Shelf HDD or SSD (CRU)

Replace a storage disk in an Oracle Database Appliance storage shelf.

 **Note:**

After a physical insertion or removal action of a storage component (such as a disk or SAS cable), you should wait before performing the next action to allow the system software to fully process the event. This could take several minutes to complete.

1. Locate the failed drive on the front of the storage shelf.

Look for the drive with its Service Required indicator and/or Ready-to-Remove indicator lit.

**⚠ Caution:**

**Equipment damage.** Do not remove a drive unless you have an immediate replacement.

**2. Remove the drive:**

- For the DE3-24C, press the release button [1] to release the drive lever and then, rotate the lever open and, grasping the drive body, slide the drive out of the storage shelf [2] as shown in the following figure.

**✎ Note:**

For the DE2-24C, slide the release latch as indicated by the debossed arrow to release the drive lever.

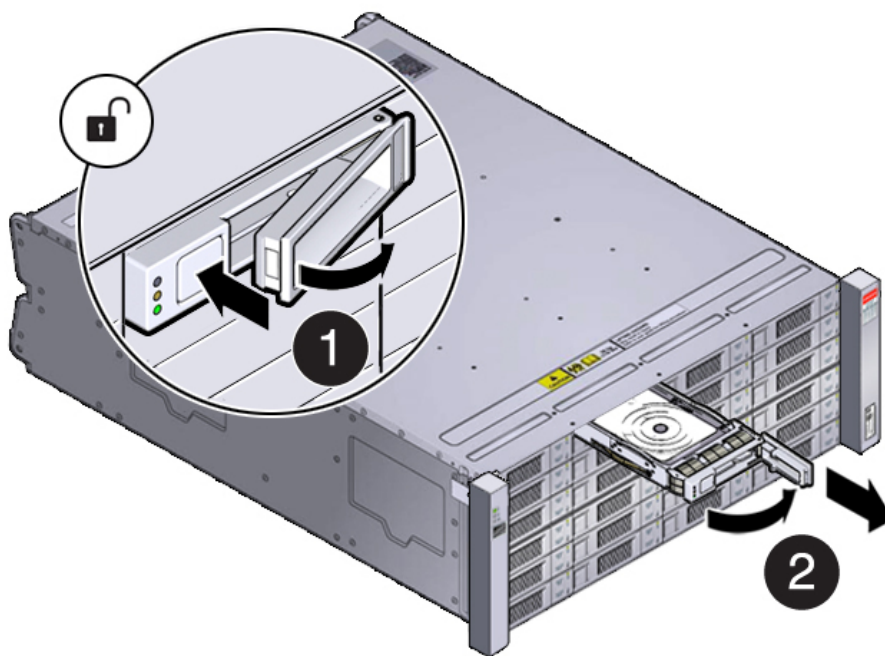

- For the DE2-24P, slide the release latch as indicated by the debossed arrow to release the drive lever and then, rotate the lever open and, grasping the drive body, slide the drive out of the storage shelf as shown in the following figure.

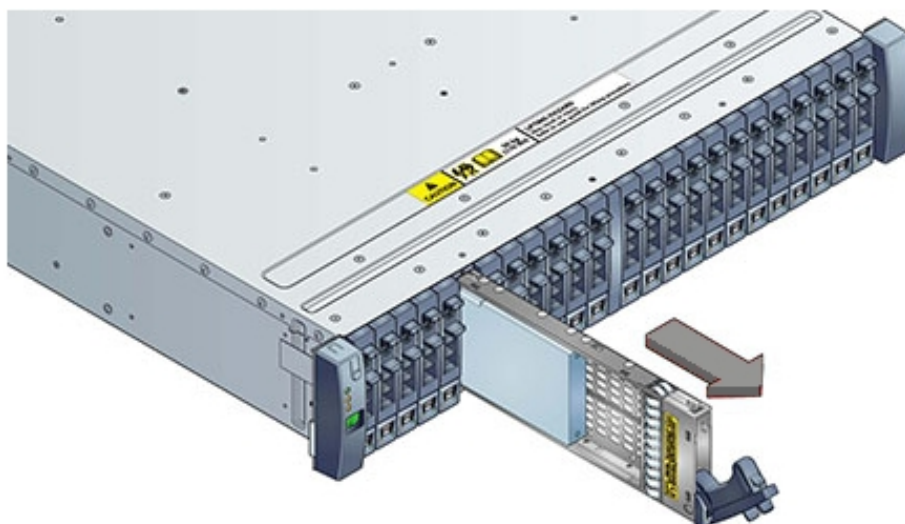

3. Install the replacement drive:

- For the DE2-24C and DE3-24C, open the drive lever on the replacement drive. Slide the new drive into the drive slot [1] until it engages with the backplane connector and then close the lever to fully seat the drive and lock it into place [2] as shown in the following figure.

Check that the drive is locked in place and flush with the other drives.

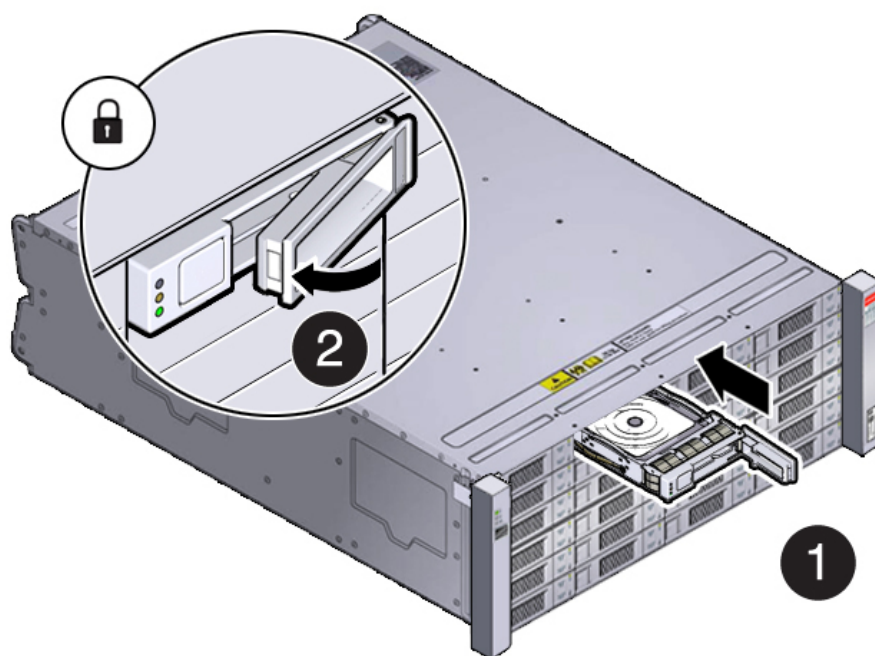

- For the DE2-24P, open the drive lever on the replacement drive. Slide the drive into the drive slot until it engages with the backplane connector and then close the lever to fully seat the drive and lock it into place as shown in the following figure.

Check that the drive is locked in place and flush with the other drives.



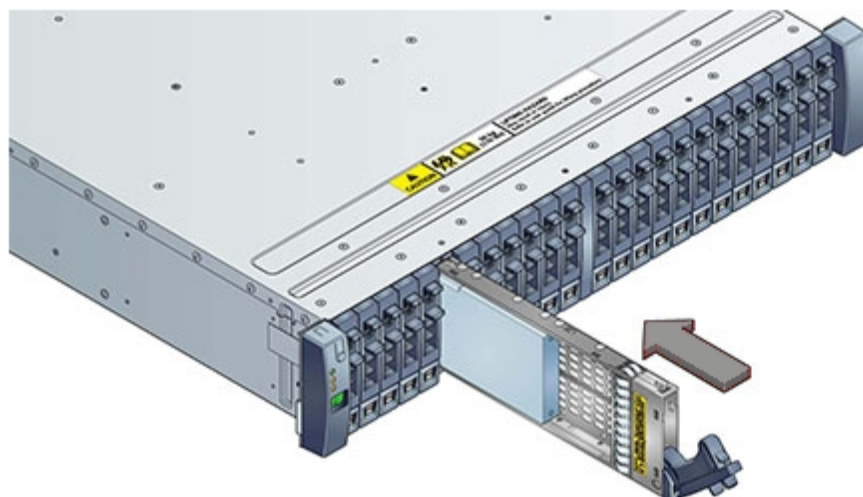

4. Once installed, the system should automatically detect and use the replacement drive. Ensure that the green OK indicator for the replacement drive lights to show that the drive is ready.

This can take a few minutes to complete.

### 3.4.1.4 Replace a Storage Shelf Power Supply (CRU)

Replace a power supply in an Oracle Database Appliance storage shelf.

The storage shelf and the storage expansion shelf each have two power supplies. Indicators (LEDs) on the power supplies indicate their operation state.

The power supplies are redundant and one can be replaced while the appliance is running.

Example figure showing a DE3-24C power supply:

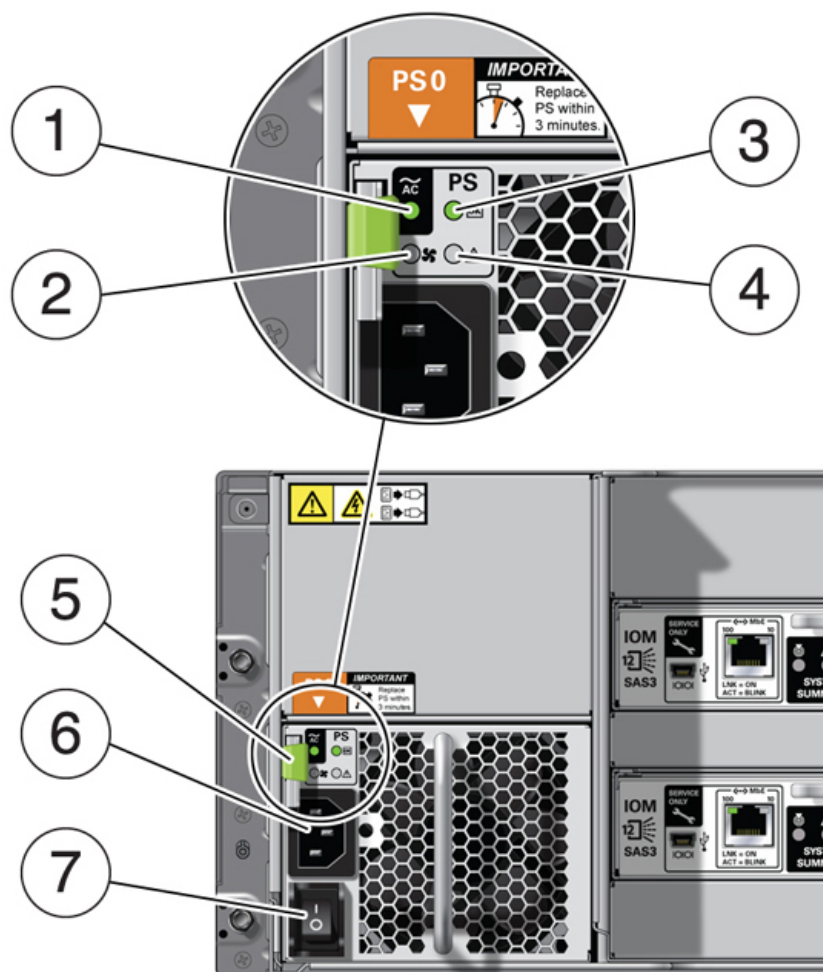

Example figure showing a DE2-24C or DE2-24P power supply:

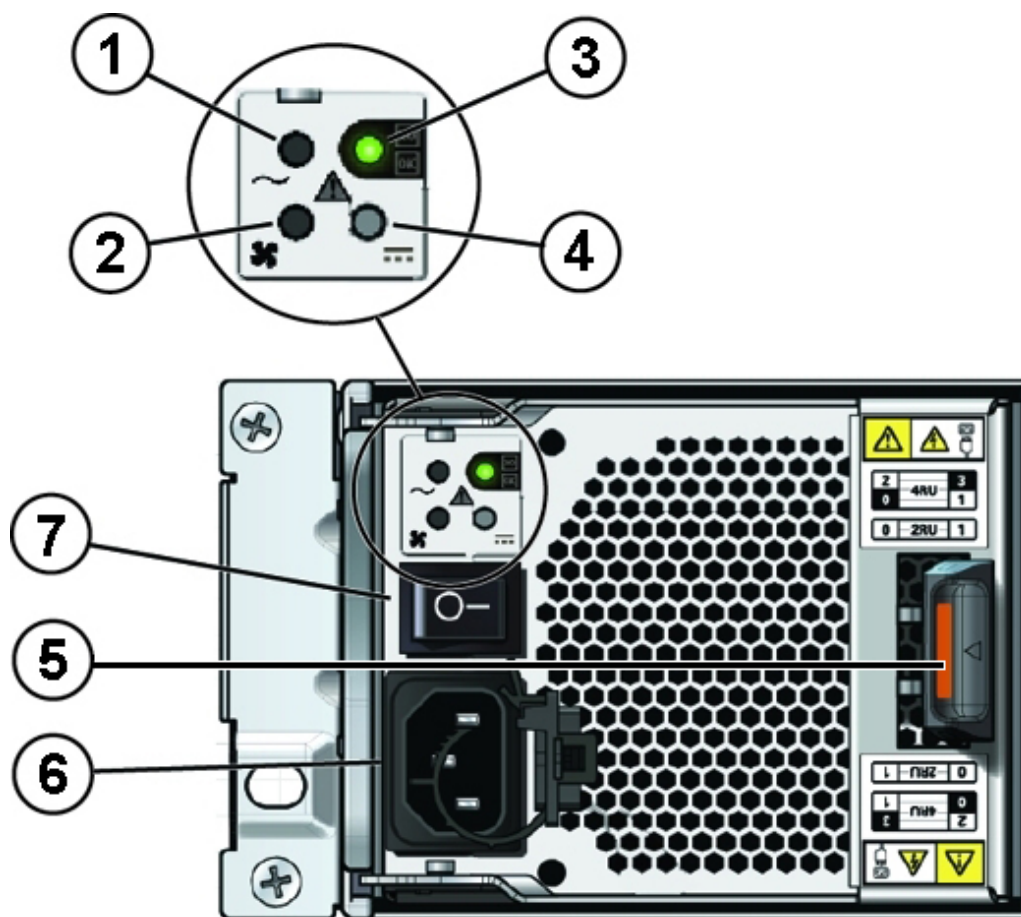

Callout	Description
---------	-------------

1	AC power fail indicator
2	Fan fail indicator
3	Power supply status indicator
4	DC power fail indicator
5	Release lever
6	AC connector
7	On/Off switch

If any of the indicators are amber, or if the power supply status indicator does not light, replace the power supply.

1. Ensure the power supply on/off switch is in the "O" off position.
2. Disconnect the power cord tie strap from the power cord, and unplug the power cord from the power supply.
3. Remove the power supply unit using the procedure for your storage shelf model:
  - For the DE3-24C, grasp the power supply handle, push the release button [1], and slide the power supply out of the chassis [2] as shown in the following figure.



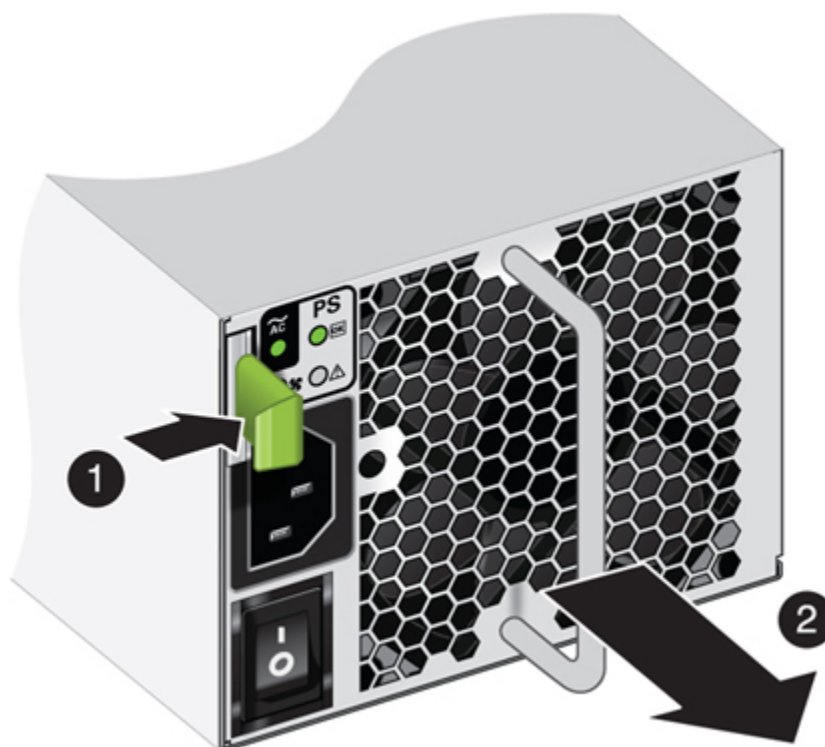

- For the DE2-24C or DE2-24P, push the ejector release button [1], grasp the power supply ejector handle and rotate it to the open position [2] as shown in the following figure. Slide the power supply out of the chassis.

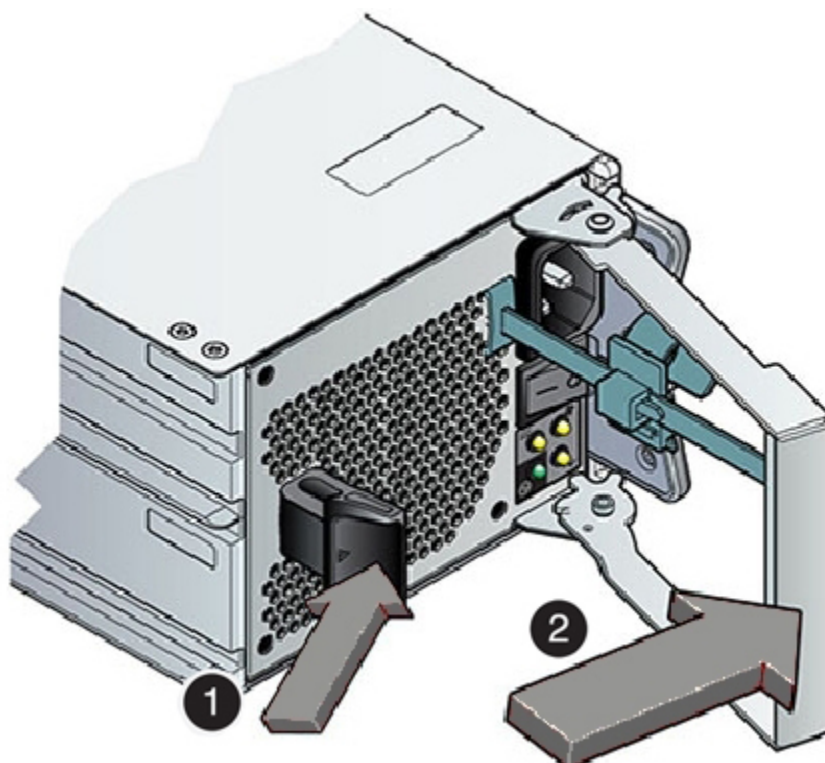

4. Open the lever/ejection arms on the replacement power supply.
  5. Slide the replacement power supply module into the chassis.  
Be careful to not bend the pins.
  6. Close the lever/ejection arms.  
Push the lever fully closed until you hear or feel a click.
- [Replace a Storage Shelf I/O Module \(CRU\)](#) (page 3-28)  
Replace an IO module in an Oracle Database Appliance storage shelf.

### 3.4.1.4.1 Replace a Storage Shelf I/O Module (CRU)

Replace an IO module in an Oracle Database Appliance storage shelf.

Storage Shelf SAS I/O modules are fully redundant and can be replaced while the appliance is running.

#### Note:

After a physical insertion or removal action of a storage component (such as a disk or SAS cable), you should wait before performing the next action to allow the system software to fully process the event. This could take up to 3 minutes to complete.

1. Disconnect the cables from the I/O module (the various models are shown below).  
Be sure to mark the cables so you can return them to their proper connectors.
  - Example figure showing the DE3-24C (callout descriptions are listed in the table below):

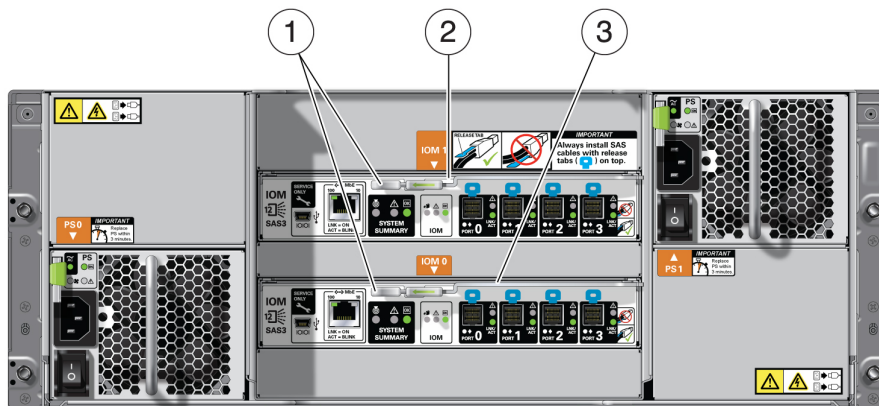

- Example figure showing the DE2-24C (callout descriptions are listed in the table below):

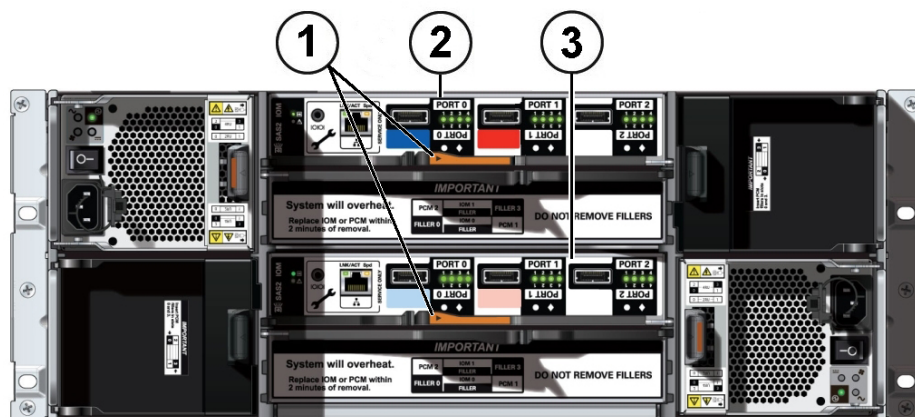

- Example figure showing the DE2-24P (callout descriptions are listed in the table below):

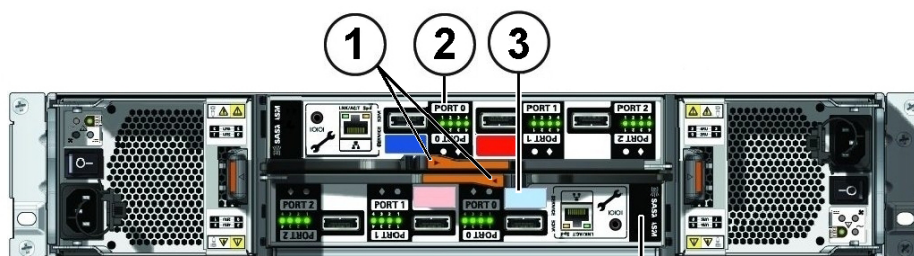

---

#### Callout Description

---

1	I/O module locking levers
2	I/O module 1 (top)
3	I/O module 0 (bottom)

---

2. Remove the I/O module using the procedure for your storage shelf model:
  - For the DE3-24C, using your thumb and forefinger, pinch the release buttons [1] together to release the locking lever [2] as shown in the following figure. Grasp the lever and remove the I/O module from the chassis [3] as shown in the following figure.

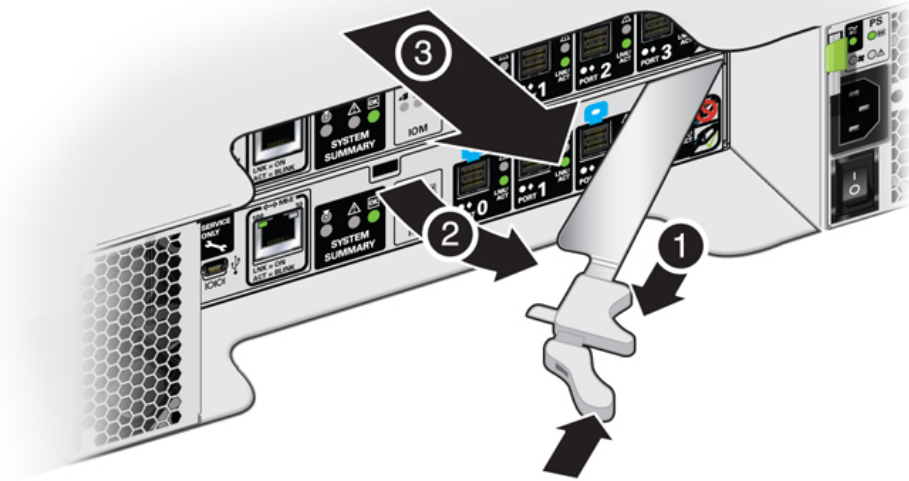

- For the DE2-24C or DE2-24P, using your thumb and forefinger, squeeze the release button [1] toward the locking lever hole to release the lever [2]. Grasp the lever and remove the I/O module from the chassis.

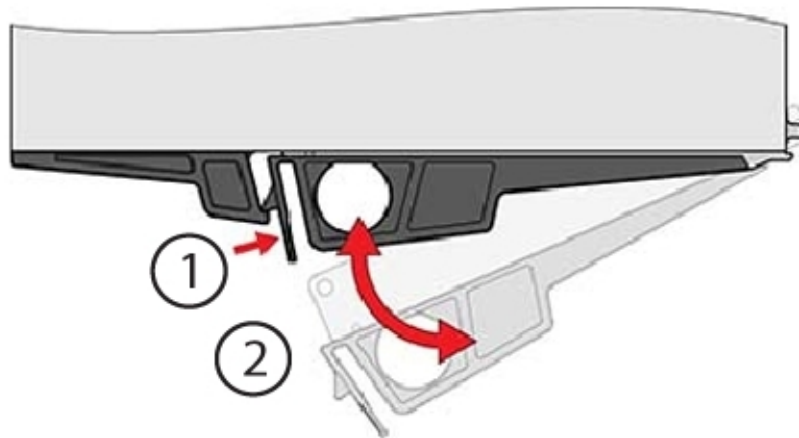

3. Open the lever in the new I/O module if it is not already open.
4. Slide the new I/O module into the disk shelf and close the locking lever.

**⚠ Caution:**

**Equipment damage.** Be careful not to damage the connector pins at the back of the I/O module.

5. Reconnect the cables.
6. Verify that the new I/O module is working correctly.
  - After approximately 60 seconds, the power LED should be solid green and the Fault/Locate LED should be off.

- For each port that has a cable connected, all four activity LEDs should be solid green.

## 3.5 Oracle Database Appliance Version 1 Hot-Pluggable Components

This section describes how to perform hot plug tasks on an Oracle Database Appliance Version 1 system.

If you have Oracle Database Appliance X7-2 series, go to [Oracle Database Appliance X7-2 Series Server Node Hot-Pluggable Components](#) (page 3-1). If you have Oracle Database Appliance X6-2 series, go to [Oracle Database Appliance X6-2 Series Server Node Hot-Pluggable Components](#) (page 3-6). If you have Oracle Database Appliance X3-2/X4-2/X5-2, go to [Oracle Database Appliance X3-2/X4-2/X5-2 Hot-Pluggable Components](#) (page 3-12).

Only certain versions of Oracle Database Appliance support a storage shelf (the Oracle Database Appliance Version 1 does not). If you have Oracle Database Appliance that supports a storage shelf and you need to service its components, go to [Oracle Database Appliance X3-2/X4-2/X5-2 and X6-2-HA/X7-2-HA Storage Shelf Hot-Pluggable Components](#) (page 3-13).

Hot-pluggable components are those that can be removed and installed while the system and the server nodes are running. These are designated as Customer Replaceable Units (CRUs).

In Oracle Database Appliance Version 1, the following devices are hot-pluggable:

- Storage and Boot Drives. See [Servicing Storage Drives and Boot Drives \(CRU\)](#) (page A-14).
- Fan modules. See [Servicing Fan Modules \(CRU\)](#) (page A-22)
- Power supplies. See [Servicing Power Supplies \(CRU\)](#) (page A-25)

# 4

## Servicing CRUs That Require Server Node Power Off

Perform tasks for servicing customer-replaceable units (CRUs) for the Oracle Database Appliance that require you to power off the server node.

All Oracle Database Appliance CRUs are located in the server nodes.

### Note:

The servicing of hot-plug components such as the HDDs, SSDs, power supplies, and fans is described in [Servicing CRUs That Do Not Require System Power Off](#) (page 3-1).

- [Servicing Oracle Database Appliance X7-2 Series CRUs](#) (page 4-1)  
This section describes how to perform CRU service tasks requiring system power off for Oracle Database Appliance X7 series system.
- [Servicing Oracle Database Appliance X6-2 Series CRUs](#) (page 4-2)  
This section describes how to perform CRU service tasks requiring system power off for Oracle Database Appliance X6 series system.
- [Servicing Oracle Database Appliance X3-2/X4-2/X5-2 CRUs](#) (page 4-3)  
This section describes how to perform CRU service tasks requiring system power off for Oracle Database Appliance X3-2/X4-2/X5-2 system.
- [Servicing Oracle Database Appliance Version 1 CRUs](#) (page 4-5)  
This section describes how to perform CRU service tasks requiring system power off for Oracle Database Appliance Version 1 system.

### 4.1 Servicing Oracle Database Appliance X7-2 Series CRUs

This section describes how to perform CRU service tasks requiring system power off for Oracle Database Appliance X7 series system.

If you have Oracle Database Appliance X6-2 series, go to [Servicing Oracle Database Appliance X6-2 Series CRUs](#) (page 4-2). If you have Oracle Database Appliance X3-2/X4-2/X5-2, go to [Servicing Oracle Database Appliance X3-2/X4-2/X5-2 CRUs](#) (page 4-3). If you have Oracle Database Appliance Version 1, go to [Servicing Oracle Database Appliance Version 1 CRUs](#) (page 4-5).

### Note:

When adding DIMMs to the system, refer to the "Optional Component Installation" section in the *Owner's Guide* for supported configurations.



This section describes how to service customer-replaceable units (CRUs) that require you to power off the server.



**Note:**

For the Oracle Database Appliance X7-2-HA, all of the CRUs on the storage shelf and the storage expansion shelf can be replaced while the power is on. See [Oracle Database Appliance X3-2/X4-2/X5-2 and X6-2-HA/X7-2-HA Storage Shelf Hot-Pluggable Components](#) (page 3-13) for storage shelf component replacement procedures.



**Note:**

The links in the following table take you to instructions **outside** of the Oracle Database Appliance library to the Oracle Server X7-2 documentation library. Use your browser's Back button to return to the Oracle Database Appliance library.

Oracle Database Appliance X7-2S/X7-2M	Oracle Database Appliance X7-2-HA
<a href="#">CRU List</a>	<a href="#">CRU List</a>
<a href="#">Servicing DIMMs (CRU)</a>	<a href="#">Servicing DIMMs (CRU)</a>
<a href="#">Servicing PCIe Risers (CRU)</a>	<a href="#">Servicing PCIe Risers (CRU)</a>
<a href="#">Servicing PCIe Cards (CRU)</a>	<a href="#">Servicing PCIe Cards (CRU)</a>
<a href="#">Servicing Internal M.2 Flash SSDs (CRU)</a>	<a href="#">Servicing Internal M.2 Flash SSDs (CRU)</a>
<a href="#">Servicing Internal USB Flash Drives (CRU)</a>	<a href="#">Servicing Internal USB Flash Drives (CRU)</a>
<a href="#">Servicing the Battery (CRU)</a>	<a href="#">Servicing the Battery (CRU)</a>

## 4.2 Servicing Oracle Database Appliance X6-2 Series CRUs

This section describes how to perform CRU service tasks requiring system power off for Oracle Database Appliance X6 series system.

If you have Oracle Database Appliance X7-2 series, go to [Servicing Oracle Database Appliance X7-2 Series CRUs](#) (page 4-1). If you have Oracle Database Appliance X3-2/X4-2/X5-2, go to [Servicing Oracle Database Appliance X3-2/X4-2/X5-2 CRUs](#) (page 4-3). If you have Oracle Database Appliance Version 1, go to [Servicing Oracle Database Appliance Version 1 CRUs](#) (page 4-5).



**Note:**

When adding DIMMs to the system, refer to the "Optional Component Installation" section in the *Owner's Guide* for supported configurations.

This section describes how to service customer-replaceable units (CRUs) that require you to power off the server.

 **Note:**

For the Oracle Database Appliance X6-2-HA, all of the CRUs on the storage shelf and the storage expansion shelf can be replaced while the power is on. See [Oracle Database Appliance X3-2/X4-2/X5-2 and X6-2-HA/X7-2-HA Storage Shelf Hot-Pluggable Components](#) (page 3-13) for storage shelf component replacement procedures.

 **Note:**

The links in the following table take you to instructions **outside** of the Oracle Database Appliance library to the Oracle Server X6-2 and Oracle Server X6-2L (including Storage Server X6-2 Extreme Flash version) documentation libraries. Use your browser's Back button to return to the Oracle Database Appliance library.

Oracle Database Appliance X6-2S/X6-2M	Oracle Database Appliance X6-2L	Oracle Database Appliance X6-2-HA
<a href="#">CRU List</a>	<a href="#">CRU List</a>	<a href="#">CRU List</a>
<a href="#">Servicing DIMMs (CRU)</a>	<a href="#">Servicing DIMMs (CRU)</a>	<a href="#">Servicing DIMMs (CRU)</a>
<a href="#">Servicing PCIe Risers (CRU)</a>	This system does not have PCIe risers.	<a href="#">Servicing PCIe Risers (CRU)</a>
<a href="#">Servicing PCIe Cards (CRU)</a>	<a href="#">Servicing PCIe Cards (CRU)</a>	<a href="#">Servicing PCIe Cards (CRU)</a>
<a href="#">Servicing Internal USB Flash Drives (CRU)</a>	<a href="#">Servicing Internal USB Flash Drives (CRU)</a>	<a href="#">Servicing Internal USB Flash Drives (CRU)</a>
<a href="#">Servicing the Battery (CRU)</a>	<a href="#">Servicing the Battery (CRU)</a>	<a href="#">Servicing the Battery (CRU)</a>

## 4.3 Servicing Oracle Database Appliance X3-2/X4-2/X5-2 CRUs

This section describes how to perform CRU service tasks requiring system power off for Oracle Database Appliance X3-2/X4-2/X5-2 system.

If you have Oracle Database Appliance X7-2 series, go to [Servicing Oracle Database Appliance X7-2 Series CRUs](#) (page 4-1). If you have Oracle Database Appliance X6-2 series, go to [Servicing Oracle Database Appliance X6-2 Series CRUs](#) (page 4-2). If you have Oracle Database Appliance Version 1, go to [Servicing Oracle Database Appliance Version 1 CRUs](#) (page 4-5).



 **Note:**

When adding DIMMs to the system, refer to the "Optional Component Installation" section in the *Owner's Guide* for supported configurations.

This section describes how to service customer-replaceable units (CRUs) that require you to power off the server.

 **Note:**

All of the CRUs on the storage shelf and the storage expansion shelf can be replaced while the power is on. See [Oracle Database Appliance X3-2/X4-2/X5-2 and X6-2-HA/X7-2-HA Storage Shelf Hot-Pluggable Components](#) (page 3-13) for storage shelf component replacement procedures.

 **Note:**

The links in the following table take you to instructions **outside** of the Oracle Database Appliance library to the Sun Server X3-2, Sun Server X4-2, and Oracle Server X5-2 documentation libraries. Use your browser's Back button to return to the Oracle Database Appliance library.

Oracle Database Appliance X3-2	Oracle Database Appliance X4-2	Oracle Database Appliance X5-2
<a href="#">CRU Locations</a>	<a href="#">CRU Locations</a>	<a href="#">CRU List</a>
<a href="#">Servicing DIMMs (CRU)</a>	<a href="#">Servicing DIMMs (CRU)</a>	<a href="#">Servicing DIMMs (CRU)</a>
<a href="#">Servicing PCIe Risers (CRU)</a>	<a href="#">Servicing PCIe Risers (CRU)</a>	<a href="#">Servicing PCIe Risers (CRU)</a>
<a href="#">Servicing PCIe Cards (CRU)</a>	<a href="#">Servicing PCIe Cards (CRU)</a>	<a href="#">Servicing PCIe Cards (CRU)</a>
<a href="#">Servicing a DVD Drive (CRU)</a>	<a href="#">Servicing a DVD Drive (CRU)</a>	An optional DVD drive for this system is considered a FRU. See <a href="#">Servicing Oracle Database Appliance X3-2/X4-2/X5-2 FRUs</a> (page 5-10).
This system does not include an internal USB flash drive.	<a href="#">Servicing the Internal USB Flash Drives (CRU)</a> Note that a factory installed flash drive is reserved for future use.	<a href="#">Servicing the Internal USB Flash Drives (CRU)</a> Note that a factory installed flash drive is reserved for future use.
<a href="#">Servicing the Battery (CRU)</a>	<a href="#">Servicing the Battery (CRU)</a>	<a href="#">Servicing the Battery (CRU)</a>

## 4.4 Servicing Oracle Database Appliance Version 1 CRUs

This section describes how to perform CRU service tasks requiring system power off for Oracle Database Appliance Version 1 system.

If you have Oracle Database Appliance X7-2 series, go to [Servicing Oracle Database Appliance X7-2 Series CRUs](#) (page 4-1). If you have Oracle Database Appliance X6-2 series, go to [Servicing Oracle Database Appliance X6-2 Series CRUs](#) (page 4-2). If you have Oracle Database Appliance X3-2/X4-2/X5-2, go to [Servicing Oracle Database Appliance X3-2/X4-2/X5-2 CRUs](#) (page 4-3).

This section includes information on how to service the following Oracle Database Appliance Version 1 CRUs:

- [Server Node CRU Component Locations](#) (page A-29)
- [Servicing Memory Modules \(DIMMs\) \(CRU\)](#) (page A-30)
- [Servicing PCIe Risers \(CRU\)](#) (page A-37)
- [Servicing PCIe Cards \(CRU\)](#) (page A-41)
- [Servicing the Server Node Battery \(CRU\)](#) (page A-49)

# 5

## Servicing FRUs

Perform tasks for servicing field-replaceable units (FRUs) for the Oracle Database Appliance that require you to power off the system and/or server node.

When servicing FRU components, the server node and/or system must be powered down and the AC power cords disconnected.

### Note:

Only authorized Oracle Service personnel can service FRU components.

- [Servicing Oracle Database Appliance X7-2 Series FRUs](#) (page 5-1)  
This section describes how to perform FRU service tasks on an Oracle Database Appliance X7 series system.
- [Servicing Oracle Database Appliance X6-2 Series FRUs](#) (page 5-2)  
This section describes how to perform FRU service tasks on an Oracle Database Appliance X6 series system.
- [Servicing Oracle Database Appliance X3-2/X4-2/X5-2 FRUs](#) (page 5-10)  
This section describes how to perform FRU service tasks on an Oracle Database Appliance X3-2/X4-2/X5-2 system.
- [Managing System Faults on Oracle Database Appliance X3-2/X4-2/X5-2, X6-2 Series and X7-2 Series](#) (page 5-11)  
How to manage system faults when servicing Oracle Database Appliance X3-2/X4-2/X5-2, X6-2 series and X7-2 series systems.
- [Servicing Oracle Database Appliance Version 1 FRUs](#) (page 5-12)  
This section describes how to perform FRU service tasks on an Oracle Database Appliance Version 1 system.

### 5.1 Servicing Oracle Database Appliance X7-2 Series FRUs

This section describes how to perform FRU service tasks on an Oracle Database Appliance X7 series system.

If you have Oracle Database Appliance X6-2 series, go to [Servicing Oracle Database Appliance X6-2 Series FRUs](#) (page 5-2). If you have Oracle Database Appliance X3-2/X4-2/X5-2, go to [Servicing Oracle Database Appliance X3-2/X4-2/X5-2 FRUs](#) (page 5-10). If you have Oracle Database Appliance Version 1, go to [Servicing Oracle Database Appliance Version 1 FRUs](#) (page 5-12).

Only authorized Oracle Service personnel can service FRU components.

 **Note:**

Most of the links in the following table take you to instructions **outside** of the Oracle Database Appliance library to the Oracle Server X7-2 documentation library. Use your browser's Back button to return to the Oracle Database Appliance library.

Oracle Database Appliance X7-2S/X7-2M	Oracle Database Appliance X7-2-HA
<a href="#">FRU List</a>	<a href="#">FRU List</a>
<a href="#">Servicing Processors (FRU)</a>	<a href="#">Servicing Processors (FRU)</a>
<a href="#">Servicing the Disk Backplane (FRU)</a>	<a href="#">Servicing the Disk Backplane (FRU)</a>
<a href="#">Servicing the Front Indicator Module (FRU)</a>	<a href="#">Servicing the Front Indicator Module (FRU)</a>
<a href="#">Servicing the Temperature Sensor (FRU)</a>	<a href="#">Servicing the Temperature Sensor (FRU)</a>
<a href="#">Servicing the Motherboard (FRU)</a>	<a href="#">Servicing the Motherboard (FRU)</a>
<a href="#">Servicing the NVMe Cables (FRU)</a>	The server nodes for this product do not have NVMe devices.
<a href="#">Servicing the Power, FIM, Disk Backplane Data, and Temperature Sensor Cables (FRU)</a>	<a href="#">Servicing the Power, FIM, Disk Backplane Data, and Temperature Sensor Cables (FRU)</a>
<a href="#">Component Fault Management (page 5-11)</a>	<a href="#">Component Fault Management (page 5-11)</a>

## 5.2 Servicing Oracle Database Appliance X6-2 Series FRUs

This section describes how to perform FRU service tasks on an Oracle Database Appliance X6 series system.

If you have Oracle Database Appliance X7-2 series, go to [Servicing Oracle Database Appliance X7-2 Series FRUs](#) (page 5-1). If you have Oracle Database Appliance X3-2/X4-2/X5-2, go to [Servicing Oracle Database Appliance X3-2/X4-2/X5-2 FRUs](#) (page 5-10). If you have Oracle Database Appliance Version 1, go to [Servicing Oracle Database Appliance Version 1 FRUs](#) (page 5-12).

Only authorized Oracle Service personnel can service FRU components.

 **Note:**

Most of the links in the following table take you to instructions **outside** of the Oracle Database Appliance library to the Oracle Server X6-2 and Oracle Server X6-2L (including Storage Server X6-2 Extreme Flash version) documentation libraries. Use your browser's Back button to return to the Oracle Database Appliance library.

Oracle Database Appliance X6-2S/X6-2M	Oracle Database Appliance X6-2L	Oracle Database Appliance X6-2-HA
<a href="#">FRU List</a>	<a href="#">FRU List</a>	<a href="#">FRU List</a>
<a href="#">Servicing Processors (FRU)</a>	<a href="#">Servicing Processors (FRU)</a>	<a href="#">Servicing Processors (FRU)</a>

Oracle Database Appliance X6-2S/X6-2M	Oracle Database Appliance X6-2L	Oracle Database Appliance X6-2-HA
<a href="#">Servicing the Oracle PCIe NVMe Switch Card (FRU)</a> Note that for this product, the NVMe Switch Card is located in Slot 2.	<a href="#">Servicing the Oracle PCIe NVMe Switch Card (FRU)</a> Note that for this product, the NVMe Switch Cards are located in Slots 2, 5 and 6.	This product does not have a PCIe NVMe Switch Card.
<a href="#">Servicing the internal host bus adapter (HBA) (FRU)</a>	<a href="#">Servicing the Internal SAS Host Bus Adapter (HBA) (FRU) (page 5-4)</a>	<a href="#">Servicing the internal host bus adapter (HBA) (FRU)</a>
<a href="#">Servicing the Disk Backplane (FRU)</a>	<a href="#">Servicing the Front Storage Drive Backplane (FRU)</a> <a href="#">Removing the Rear Storage Drive Backplane (FRU)</a> <a href="#">Installing the Rear Storage Drive Backplane (FRU)</a> Note that for this product, there is a single SAS cable that connects directly from the PCIe HBA in slot 3 to the rear storage drive backplane. It does not route through the chassis mid-wall.	<a href="#">Servicing the Disk Backplane (FRU)</a>
<a href="#">Servicing the DVD Drive (FRU)</a>	This product does not include a slot for a DVD drive.	<a href="#">Servicing the DVD Drive (FRU)</a>
<a href="#">Servicing the Front Indicator Module (FRU)</a>	<a href="#">Servicing the Front LED/USB Indicator Modules (FRU)</a>	<a href="#">Servicing the Front Indicator Module (FRU)</a>
<a href="#">Servicing the Motherboard (FRU)</a>	<a href="#">Servicing the Motherboard (FRU)</a>	<a href="#">Servicing the Motherboard (FRU)</a>
<a href="#">Servicing the SAS Cables (FRU)</a>	<a href="#">Replace the Internal SAS HBA Cables (page 5-8)</a> Note that for this product, there is a single SAS cable that connects directly from the PCIe HBA in slot 3 to the rear storage drive backplane. It does not route through the chassis mid-wall.	<a href="#">Servicing the SAS Cables (FRU)</a>
<a href="#">Servicing the NVMe Cables (FRU)</a> Note that the NVMe Switch Card is located in PCIe slot 2 for this product.	<a href="#">Servicing the NVMe Cables (FRU)</a> Note that the NVMe Switch Cards are located in PCIe slots 2, 5 and 6 for this product.	This product does not have NVMe devices.
<a href="#">Servicing the Power, FIM, Disk Backplane Data, and DVD Cables (FRU)</a>	For this product, cabling for Front Indicator Modules and the disk backplanes are included as part of the FRU servicing procedure for those components listed earlier in this table.	<a href="#">Servicing the Power, FIM, Disk Backplane Data, and DVD Cables (FRU)</a>
<a href="#">Component Fault Management (page 5-11)</a>	<a href="#">Component Fault Management (page 5-11)</a>	<a href="#">Component Fault Management (page 5-11)</a>

- [Servicing the Internal SAS Host Bus Adapter \(HBA\) \(FRU\)](#) (page 5-4)  
Perform tasks for servicing a SAS HBA in an Oracle Database Appliance X6-2L system.

## 5.2.1 Servicing the Internal SAS Host Bus Adapter (HBA) (FRU)

Perform tasks for servicing a SAS HBA in an Oracle Database Appliance X6-2L system.

This section describes servicing the internal Oracle Storage 12 Gb/s SAS PCIe RAID HBA in an Oracle Database Appliance X6-2L system.

- [Replace the Internal SAS HBA Card](#) (page 5-4)  
How to replace a SAS HBA in an Oracle Database Appliance X6-2L system.
- [Replace the Internal SAS HBA Cables](#) (page 5-8)  
How to replace a SAS HBA cables in an Oracle Database Appliance X6-2L system.

### 5.2.1.1 Replace the Internal SAS HBA Card

How to replace a SAS HBA in an Oracle Database Appliance X6-2L system.

#### **Caution:**

Ensure that all power is removed from the server before removing or installing PCIe cards. You must disconnect all power cables from the system before performing these procedures.

1. Prepare the server for service.  
Refer to [Preparing Oracle Database Appliance X6-2 Series for Service](#) (page 2-2) for additional details.
  - a. Power off the server and disconnect the power cords from the power supplies.
  - b. Extend the server to the maintenance position.
  - c. Attach an antistatic wrist strap.
  - d. Remove the server top cover.
2. Remove the super capacitor from the chassis.
  - a. Grasp both ends of the cable connector, press in on the release latch, and then unplug the connector [1] as shown in the following figure.  
  
The HBA super capacitor is secured to the air baffle by a recloseable fastener, which allows it to be easily removed and replaced.

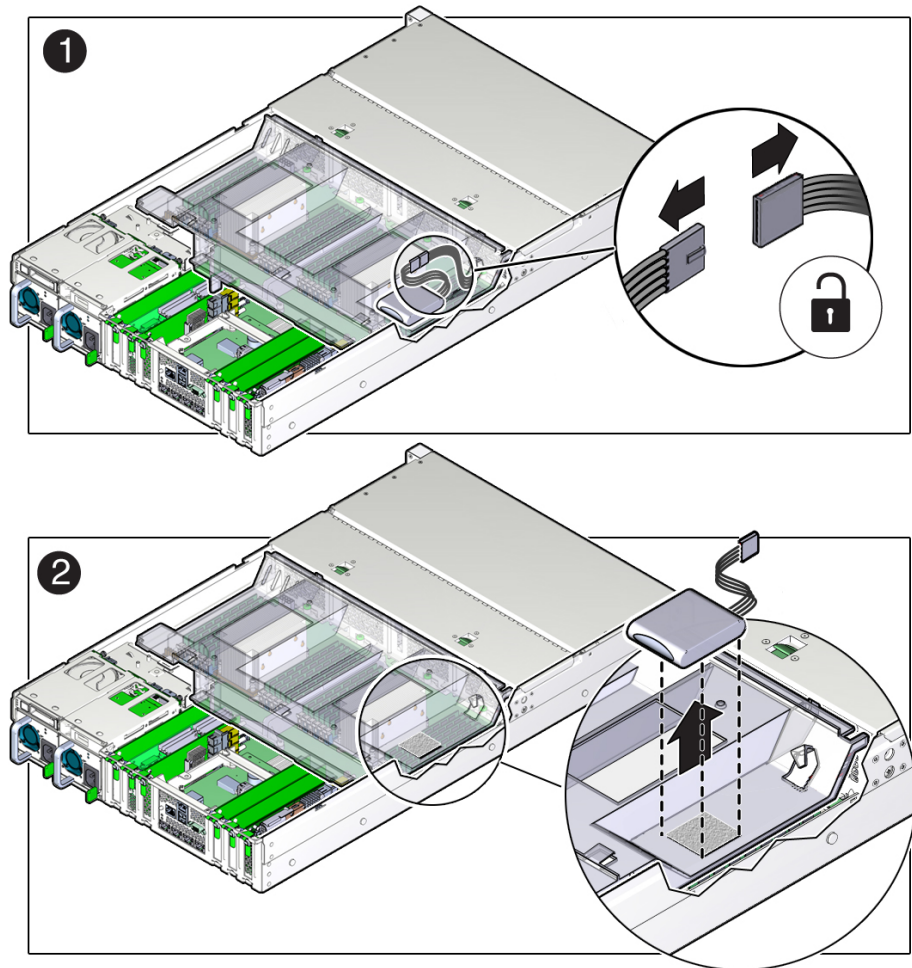

- b. To separate the HBA super capacitor from the air baffle, place your finger under the rear of the super capacitor and lift up [2] as shown in the previous figure.
3. Swivel the air baffle into the upright position to allow access to the super capacitor cable and the SAS HBA card.
4. Rotate the PCIe card locking mechanism, and then lift up on the PCIe HBA card to disengage it from the motherboard connectors [1] as shown in the following figure.

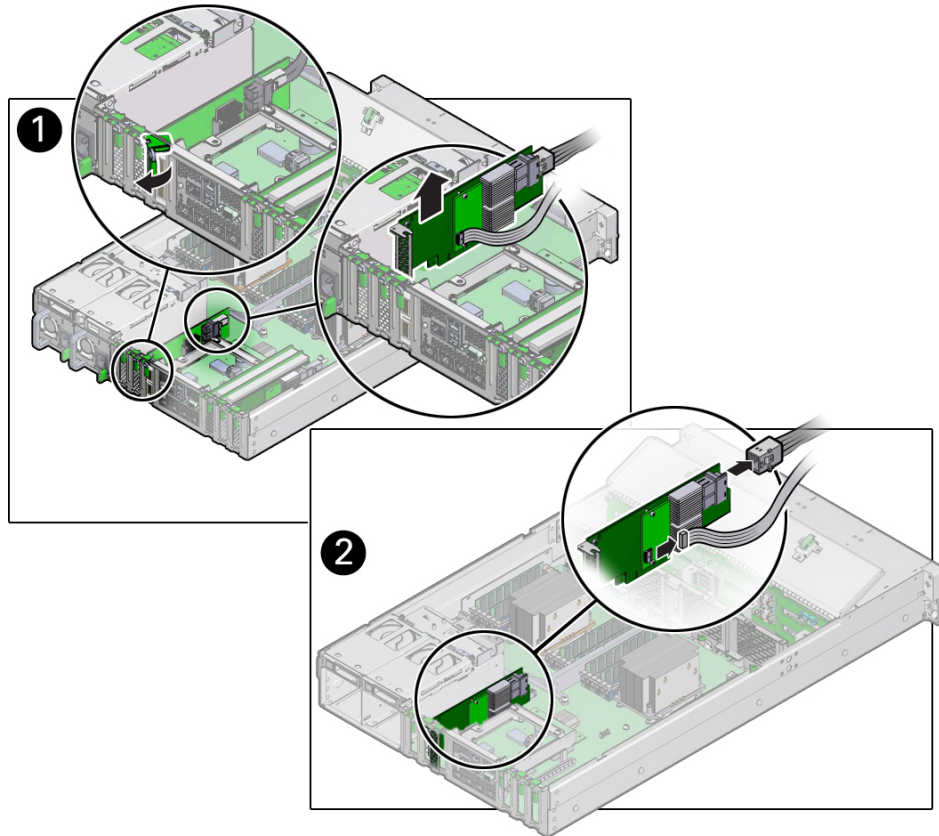

5. Disconnect the super capacitor cable and the SAS cables from the SAS HBA card [2] as shown in the previous figure.
6. Remove the SAS HBA card from the chassis.
7. Remove super capacitor cable from the chassis.  
The super capacitor cable is routed along the left side of the chassis (when facing the front of the system).
8. Unpack the replacement Oracle Storage 12 Gb/s SAS PCIe RAID HBA card and super capacitor, and place them on an antistatic mat.
9. If it isn't already, swivel the air baffle into the upright position and install the super capacitor cable along the left side of the chassis and into its access hole in the air baffle.  
Install the super capacitor cable along the left side of the chassis (when facing the front of the system). Thread the cable connector through the hole on the bottom of the air baffle to where the super capacitor will be installed. Check to ensure it does not interfere with the air baffle when it closes.
10. Connect the super capacitor cable to the SAS HBA card, and then reconnect the SAS cables that you unplugged during the removal procedure [1] as shown in the following figure.



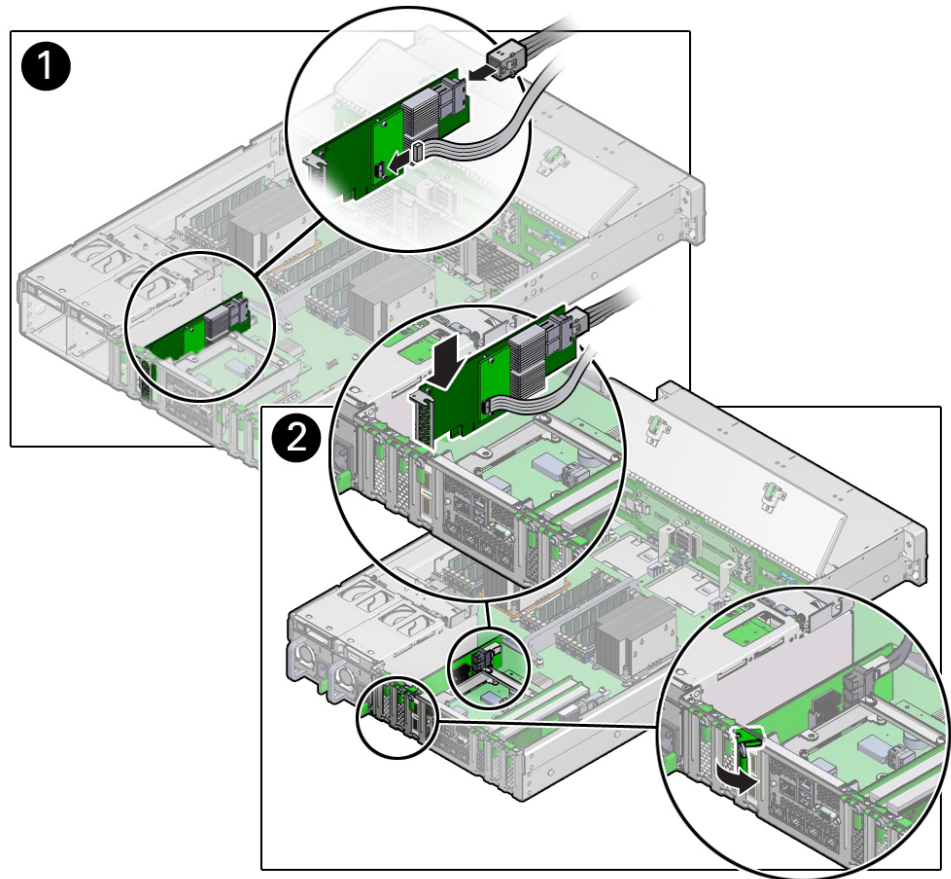

11. Insert the SAS HBA card into PCIe slot 3, and rotate the PCIe locking mechanism to secure the PCIe HBA card in place [2] as shown in the previous figure.

 **Note:**

PCIe slot 3 is the reserved slot for the Oracle Storage 12 Gb/s SAS PCIe RAID HBA card.

12. Install the super capacitor in the chassis.
  - a. Lower the air baffle to the installed position.
  - b. Align the recloseable fastener on the super capacitor with the recloseable fastener on the air baffle and press down [1] as shown in the following figure.

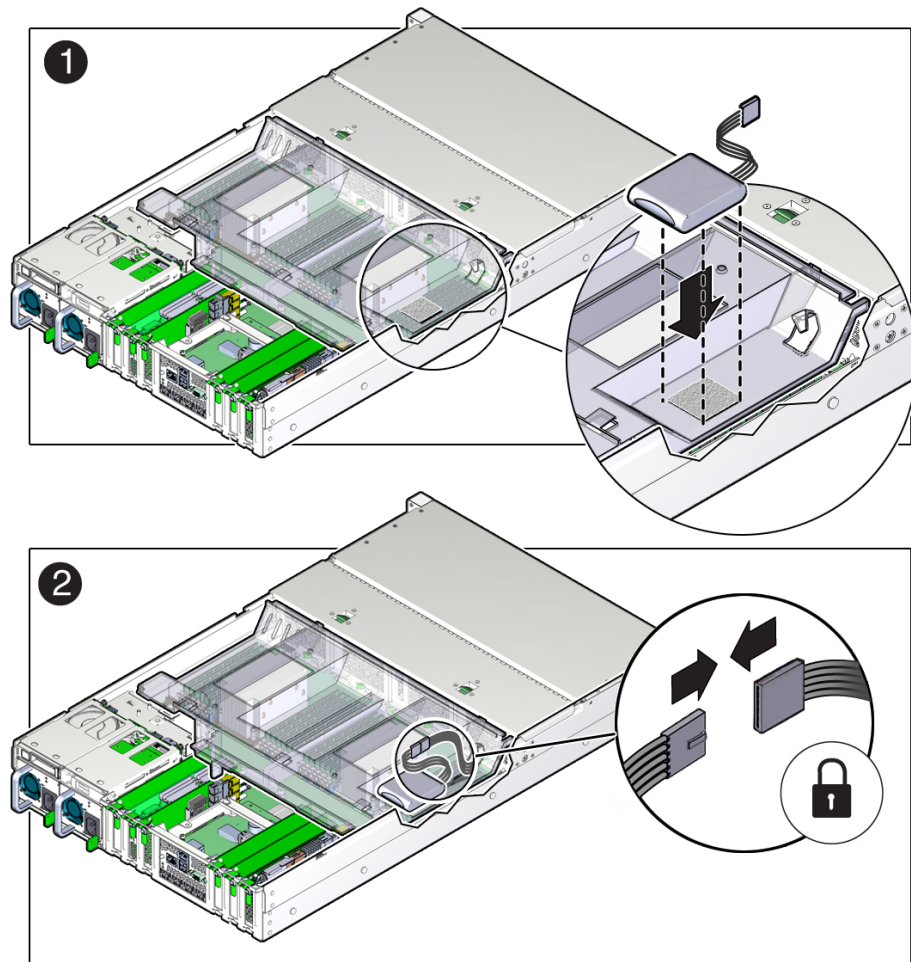

- c. Connect the super capacitor cable to the super capacitor [2] as shown in the previous figure.
13. Return the server to operation.
- a. Install the server top cover.
  - b. Return the server to the normal rack position.
  - c. Reconnect the power cords to the power supplies and power on the server.
14. Use Oracle ILOM to clear any server PCIe card faults.

You can use the Oracle ILOM web interface or the command-line interface (CLI) to manually clear faults. For information on how to use the Oracle ILOM web interface or the CLI to clear server faults, refer to the Oracle Integrated Lights Out Manager (ILOM) Documentation Library at <http://www.oracle.com/goto/ilom/docs>.

### 5.2.1.2 Replace the Internal SAS HBA Cables

How to replace a SAS HBA cables in an Oracle Database Appliance X6-2L system.

These instructions describe replacing SAS cables for the factory installed Oracle Storage 12 Gb/s SAS PCIe RAID HBA in an Oracle Database Appliance X6-2L system.

**▲ Caution:**

The system supplies power to the cables even when the server is powered off. To avoid personal injury or damage to the server, you must disconnect power cords before servicing the cables.

1. Prepare the server for service.  
Refer to [Preparing Oracle Database Appliance X6-2 Series for Service](#) (page 2-2) for additional details.
  - a. Power off the server and disconnect the power cords from the power supplies.
  - b. Extend the server to the maintenance position.
  - c. Attach an antistatic wrist strap.
  - d. Remove the server top cover.
2. Swivel the air baffle into the upright position to allow access to the SAS storage drive cables.
3. Disconnect the SAS cable from the rear disk drive backplane [1] and from the card [2] as shown in the following figure.

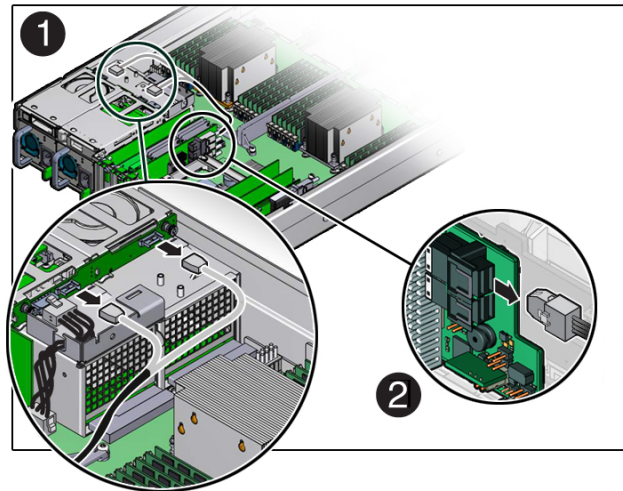

4. Install the replacement SAS cable to the rear disk drive backplane [1] and the SAS card [2] as shown in the following figure.

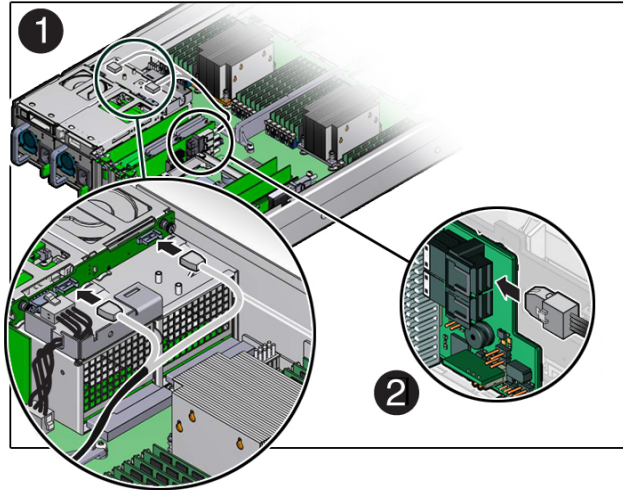

5. Lower the air baffle to the installed position.
6. Return the server to operation.
  - a. Install the server top cover.
  - b. Return the server to the normal rack position.
  - c. Reconnect the power cords to the power supplies and power on the server.

## 5.3 Servicing Oracle Database Appliance X3-2/X4-2/X5-2 FRUs

This section describes how to perform FRU service tasks on an Oracle Database Appliance X3-2/X4-2/X5-2 system.

If you have Oracle Database Appliance X7-2 series, go to [Servicing Oracle Database Appliance X7-2 Series FRUs](#) (page 5-1). If you have Oracle Database Appliance X6-2 series, go to [Servicing Oracle Database Appliance X6-2 Series FRUs](#) (page 5-2). If you have Oracle Database Appliance Version 1, go to [Servicing Oracle Database Appliance Version 1 FRUs](#) (page 5-12).

Only authorized Oracle Service personnel can service FRU components.

### Note:

Most of the links in the following table take you to instructions **outside** of the Oracle Database Appliance library to the Sun Server X3-2, Sun Server X4-2, and Oracle Server X5-2 documentation libraries. Use your browser's Back button to return to the Oracle Database Appliance library.

Oracle Database Appliance X3-2	Oracle Database Appliance X4-2	Oracle Database Appliance X5-2
<a href="#">FRU Locations</a>	<a href="#">FRU Locations</a>	<a href="#">FRU List</a>
<a href="#">Servicing Processors (FRU)</a>	<a href="#">Servicing Processors (FRU)</a>	<a href="#">Servicing Processors (FRU)</a>

Oracle Database Appliance X3-2	Oracle Database Appliance X4-2	Oracle Database Appliance X5-2
<a href="#">Servicing the Disk Backplane (FRU)</a>	<a href="#">Servicing the Disk Backplane (FRU)</a>	<a href="#">Servicing the Disk Backplane (FRU)</a>
An optional DVD drive for this system is considered a CRU. See <a href="#">Servicing Oracle Database Appliance X3-2/X4-2/X5-2 CRUs</a> (page 4-3).	An optional DVD drive for this system is considered a CRU. See <a href="#">Servicing Oracle Database Appliance X3-2/X4-2/X5-2 CRUs</a> (page 4-3).	<a href="#">Servicing a DVD Drive (FRU)</a>
<a href="#">Servicing the Front Indicator Module (FRU)</a>	<a href="#">Servicing the Front Indicator Module (FRU)</a>	<a href="#">Servicing the Front Indicator Module (FRU)</a>
<a href="#">Servicing the Motherboard (FRU)</a>	<a href="#">Servicing the Motherboard (FRU)</a>	<a href="#">Servicing the Motherboard (FRU)</a>
<a href="#">Servicing the SAS Cables (FRU)</a>	<a href="#">Servicing the SAS Cables (FRU)</a>	<a href="#">Servicing the SAS Cables (FRU)</a>
<a href="#">Component Fault Management</a> (page 5-11)	<a href="#">Component Fault Management</a> (page 5-11)	<a href="#">Component Fault Management</a> (page 5-11)

## 5.4 Managing System Faults on Oracle Database Appliance X3-2/X4-2/X5-2, X6-2 Series and X7-2 Series

How to manage system faults when servicing Oracle Database Appliance X3-2/X4-2/X5-2, X6-2 series and X7-2 series systems.

This section describes how to manage system faults when servicing Oracle Database Appliance X3-2/X4-2/X5-2, X6-2 series and X7-2 series. If you have Oracle Database Appliance Version 1, go to [Servicing Oracle Database Appliance Version 1 FRUs](#) (page 5-12).

- [Component Fault Management](#) (page 5-11)  
Perform component fault management on Oracle Database Appliance X3-2/X4-2/X5-2, X6-2 series and X7-2 series systems.

### 5.4.1 Component Fault Management

Perform component fault management on Oracle Database Appliance X3-2/X4-2/X5-2, X6-2 series and X7-2 series systems.

Typically, when a faulty component is replaced and the server is returned to service, the fault state of the component in Oracle ILOM is automatically cleared and the component Service Required indicator will turn off. This is the default behavior for all components that have an embedded FRU serial number in the component firmware.

For replaced components that do not have an embedded FRU serial number, or do not automatically clear their fault state after the component has been repaired and the server is returned to service, you can use Oracle ILOM command line interface to manually clear the fault state. Use the following syntax:

```
set /path_to_target clear_fault_action=true
```

Where *path\_to\_target* is the path to the component (such as a DIMM) that had the fault.



In addition, the Fault Management shell can also be used. Use of the Fault Management shell is reserved for Oracle Service. For more information on component fault management:

- For systems with Oracle ILOM 4.0, see [Using fmadm to Administer Active Hardware Faults](#) in the Oracle Integrated Lights Out Manager Documentation Library.
- For systems with Oracle ILOM 3.2, see [Using fmadm to Administer Active Hardware Faults](#) in the Oracle Integrated Lights Out Manager Documentation Library.
- For systems with Oracle ILOM 3.1, see [Using fmadm to Administer Active Hardware Faults](#) in the Oracle Integrated Lights Out Manager Documentation Library.

## 5.5 Servicing Oracle Database Appliance Version 1 FRUs

This section describes how to perform FRU service tasks on an Oracle Database Appliance Version 1 system.

If you have Oracle Database Appliance X7-2 series, go to [Servicing Oracle Database Appliance X7-2 Series FRUs](#) (page 5-1). If you have Oracle Database Appliance X6-2 series, go to [Servicing Oracle Database Appliance X6-2 Series FRUs](#) (page 5-2). If you have Oracle Database Appliance X3-2/X4-2/X5-2, go to [Servicing Oracle Database Appliance X3-2/X4-2/X5-2 FRUs](#) (page 5-10).



### Note:

Only authorized Oracle Service personnel can service FRU components.

This section includes information on how to service the following Oracle Database Appliance Version 1 FRUs:

- [Removing and Installing the Air Duct \(FRU\)](#) (page A-52)
- [Servicing Processors \(CPUs\) \(FRU\)](#) (page A-55)
- [Servicing the Boot Disk Backplane \(FRU\)](#) (page A-61)
- [Servicing the Power Distribution Board \(FRU\)](#) (page A-63)
- [Servicing the Disk Midplane Module \(FRU\)](#) (page A-67)
- [Servicing the Disk Midplane Module HDD Cable \(FRU\)](#) (page A-72)
- [Servicing the Front Indicator Panels \(FRU\)](#) (page A-74)
- [Servicing Server Node Cables](#) (page A-78)
- [Servicing the Motherboard Assembly \(FRU\)](#) (page A-90)

# 6

## Returning Oracle Database Appliance to Operation

Perform tasks to return the Oracle Database Appliance to operation after service.

- [Returning Oracle Database Appliance X7-2 Series to Operation](#) (page 6-1)  
This section describes how to return an Oracle Database Appliance X7 series system to operation after service.
- [Returning Oracle Database Appliance X6-2 Series to Operation](#) (page 6-2)  
This section describes how to return an Oracle Database Appliance X6 series system to operation after service.
- [Returning Oracle Database Appliance X3-2/X4-2/X5-2 to Operation](#) (page 6-3)  
This section describes how to return an Oracle Database Appliance X3-2/X4-2/X5-2 system to operation after service.
- [Powering On an Oracle Database Appliance That Includes a Storage Shelf](#) (page 6-4)  
Perform tasks required to power on an Oracle Database Appliance that includes at least one storage shelf (DE2-24P, DE2-24C, or DE3-24C).
- [Returning Oracle Database Appliance Version 1 to Operation](#) (page 6-5)  
This section describes how to return an Oracle Database Appliance Version 1 system to operation after service.

### 6.1 Returning Oracle Database Appliance X7-2 Series to Operation

This section describes how to return an Oracle Database Appliance X7 series system to operation after service.

If you have Oracle Database X6-2 series, go to [Returning Oracle Database Appliance X6-2 Series to Operation](#) (page 6-2). If you have Oracle Database X3-2, Oracle Database Appliance X4-2, or Oracle Database Appliance X5-2, go to [Returning Oracle Database Appliance X3-2/X4-2/X5-2 to Operation](#) (page 6-3). If you have Oracle Database Appliance Version 1, go to [Returning Oracle Database Appliance Version 1 to Operation](#) (page 6-5).

#### Note:

Most of the links in the following table take you to instructions **outside** of the Oracle Database Appliance library to the Oracle Server X7-2 documentation library. Use your browser's Back button to return to the Oracle Database Appliance library.

Oracle Database Appliance X7-2S/X7-2M	Oracle Database Appliance X7-2-HA
<a href="#">Install the Top Cover</a>	<a href="#">Install the Top Cover</a>
<a href="#">Remove Antistatic Measures</a>	<a href="#">Remove Antistatic Measures</a>
<a href="#">Reinstall the Server Chassis Into the Rack</a>	<a href="#">Reinstall the Server Chassis Into the Rack</a>
<a href="#">Return the Server to the Normal Rack Position</a>	<a href="#">Return the Server to the Normal Rack Position</a>
<a href="#">Reconnect Data Cables and Power Cords</a>	<a href="#">Reconnect Data Cables and Power Cords</a>
<a href="#">Powering On Oracle Database Appliance X7-2S/X7-2M</a>	<a href="#">Powering On an Oracle Database Appliance That Includes a Storage Shelf</a> (page 6-4)

## 6.2 Returning Oracle Database Appliance X6-2 Series to Operation

This section describes how to return an Oracle Database Appliance X6 series system to operation after service.

If you have Oracle Database X7-2 series, go to [Returning Oracle Database Appliance X7-2 Series to Operation](#) (page 6-1). If you have Oracle Database Appliance X4-2, or Oracle Database Appliance X5-2, go to [Returning Oracle Database Appliance X3-2/X4-2/X5-2 to Operation](#) (page 6-3). If you have Oracle Database Appliance Version 1, go to [Returning Oracle Database Appliance Version 1 to Operation](#) (page 6-5).

### Note:

Most of the links in the following table take you to instructions **outside** of the Oracle Database Appliance library to the Oracle Server X6-2 and Oracle Server X6-2L (including Storage Server X6-2 Extreme Flash version) documentation libraries. Use your browser's Back button to return to the Oracle Database Appliance library.

Oracle Database Appliance X6-2S/X6-2M	Oracle Database Appliance X6-2L	Oracle Database Appliance X6-2-HA
<a href="#">Install the Top Cover</a>	<a href="#">Install the Top Cover</a> <a href="#">Install the Fan Assembly Door</a>	<a href="#">Install the Top Cover</a>
<a href="#">Remove Antistatic Measures</a>	<a href="#">Remove Antistatic Measures</a>	<a href="#">Remove Antistatic Measures</a>
<a href="#">Reinstall the Server Chassis Into the Rack</a>	<a href="#">Reinstall the Server Chassis Into the Rack</a>	<a href="#">Reinstall the Server Chassis Into the Rack</a>
<a href="#">Return the Server to the Normal Rack Position</a>	<a href="#">Return the Server to the Normal Rack Position</a>	<a href="#">Return the Server to the Normal Rack Position</a>
<a href="#">Reconnect Data Cables and Power Cords</a>	<a href="#">Reconnect Data Cables and Power Cords</a>	<a href="#">Reconnect Data Cables and Power Cords</a>
<a href="#">Powering On Oracle Database Appliance X6-2S/X6-2M</a>	<a href="#">Powering On Oracle Database Appliance X6-2L</a>	<a href="#">Powering On an Oracle Database Appliance That Includes a Storage Shelf</a> (page 6-4)



## 6.3 Returning Oracle Database Appliance X3-2/X4-2/X5-2 to Operation

This section describes how to return an Oracle Database Appliance X3-2/X4-2/X5-2 system to operation after service.

If you have Oracle Database X7-2 series, go to [Returning Oracle Database Appliance X7-2 Series to Operation](#) (page 6-1). If you have Oracle Database X6-2 series, go to [Returning Oracle Database Appliance X6-2 Series to Operation](#) (page 6-2). If you have Oracle Database Appliance Version 1, go to [Returning Oracle Database Appliance Version 1 to Operation](#) (page 6-5).

 **Note:**

Most of the links in the following table take you to instructions **outside** of the Oracle Database Appliance library to the Sun Server X3-2, Sun Server X4-2 and Oracle Server X5-2 documentation libraries. Use your browser's Back button to return to the Oracle Database Appliance library.

Oracle Database Appliance X3-2	Oracle Database Appliance X4-2	Oracle Database Appliance X5-2
<a href="#">Install the Top Cover</a>	<a href="#">Install the Top Cover</a>	<a href="#">Install the Top Cover</a>
<a href="#">Remove Antistatic Measures</a>	<a href="#">Remove Antistatic Measures</a>	<a href="#">Remove Antistatic Measures</a>
<a href="#">Reinstall the Server Chassis Into the Rack</a>	<a href="#">Reinstall the Server Chassis Into the Rack</a>	<a href="#">Reinstall the Server Chassis Into the Rack</a>
<a href="#">Return the Server to the Normal Rack Position</a>	<a href="#">Return the Server to the Normal Rack Position</a>	<a href="#">Return the Server to the Normal Rack Position</a>
<a href="#">Reconnect Data Cables and Power Cords</a>	<a href="#">Reconnect Data Cables and Power Cords</a>	<a href="#">Reconnect Data Cables and Power Cords</a>
<a href="#">Powering On an Oracle Database Appliance That Includes a Storage Shelf (page 6-4)</a>	<a href="#">Powering On an Oracle Database Appliance That Includes a Storage Shelf (page 6-4)</a>	<a href="#">Powering On an Oracle Database Appliance That Includes a Storage Shelf (page 6-4)</a>

## 6.4 Powering On an Oracle Database Appliance That Includes a Storage Shelf

Perform tasks required to power on an Oracle Database Appliance that includes at least one storage shelf (DE2-24P, DE2-24C, or DE3-24C).

 **Note:**

If you have an Oracle Database Appliance X7-2S/X7-2M, X6-2S/X6-2M/X6-2L or Oracle Database Appliance Version 1, your system does not support a storage shelf and you should skip this section.

When powering on the system, each server node is powered on separately.

1. If you powered off and disconnected the power cords from a storage shelf (and storage expansion shelf if one is present), reconnect the power cords now.
2. Power on the storage shelf (and storage expansion shelf if one is present) by switching the power supply On/Off button on each power supply to the On position.

The disks begin to initialize and the power supply LEDs light green. This can take several minutes.

 **Note:**

Do not power on the server nodes until the disks on the storage shelf and storage expansion shelf have initialized.

3. If you powered off a server node, reconnect any unplugged power cords.
4. Power on a server node on using one of the following methods:
  - Press the recessed Power button on the server node front panel.
  - Log in to the Oracle ILOM web interface, click Host Management > Power Control, and select **Power On** from the Select Action list box.
  - Log in to the Oracle ILOM command-line interface (CLI), and type the following command at the Oracle ILOM CLI prompt.

```
-> start /SYS
```

When the server is powered on and the power-on self-test (POST) code checkpoint tests have completed, the green Power/OK status indicator on the server node front panel lights and remains lit.

 **Note:**

If you powered off both server nodes prior to servicing, repeat steps 3 and 4 to power on the second server node.

5. Refer to other Oracle Database Appliance documentation for any instructions or commands required to return the appliance to service.

Refer to the appropriate *Deployment and User's Guide* for the Oracle Database Appliance X7 series and X6 series, or the *Administration and Reference Guide* for the Oracle Database Appliance X3-2/X4-2/X5-2 or Oracle Database Appliance Version 1.

## 6.5 Returning Oracle Database Appliance Version 1 to Operation

This section describes how to return an Oracle Database Appliance Version 1 system to operation after service.

If you have Oracle Database X7-2 series, go to [Returning Oracle Database Appliance X7-2 Series to Operation](#) (page 6-1). If you have Oracle Database X6-2 series, go to [Returning Oracle Database Appliance X6-2 Series to Operation](#) (page 6-2). If you have Oracle Database Appliance X3-2/X4-2/X5-2, go to [Returning Oracle Database Appliance X3-2/X4-2/X5-2 to Operation](#) (page 6-3).

- [Installing the Server Node Top Cover](#) (page A-95)
- [Installing a Server Node Into the System Chassis](#) (page A-96)
- [Powering On Oracle Database Appliance Version 1](#) (page A-98)

# 7

## Server Node Diagnostic Tools and Resetting the Service Processor

Learn about server node diagnostic tools and how to reset the SP.

Diagnostic tools are used to troubleshoot or monitor the performance of your system. Data gathered by the service processor (SP) of each server node helps in monitoring and identifying problems with server node hardware. If the SP hangs or becomes inaccessible, it might need to be reset.

### Note:

Most of the tools and procedures described in this chapter are reserved for Oracle Service personnel and should not be run on the appliance unless directed to do so by Oracle Service.

- [Server Node Diagnostic Tools](#) (page 7-1)  
See a listing of the various Oracle Database Appliance diagnostic tools and where to obtain more information about them.
- [Resetting the Service Processor](#) (page 7-3)  
How to reset the service processor (SP) of a server node of an Oracle Database Appliance.

### 7.1 Server Node Diagnostic Tools

See a listing of the various Oracle Database Appliance diagnostic tools and where to obtain more information about them.

Oracle provides a wide selection of diagnostic tools for use with your server node. These tools include lights out management of the system, service processor recovery, power-on self-test (POST), UEFI or Pc-Check diagnostics, as well as hardware LEDs that indicate the status of system components.

### Note:

The links in the following table take you to instructions **outside** of the Oracle Database Appliance library. Use your browser's Back button to return to the Oracle Database Appliance library.

Diagnostic Tool	What It Does	Where to Find Information
Oracle Integrated Lights Out Manager (ILOM)	<p>Monitors server status, environmental conditions, generates alerts (SNMP traps, IPMI PEs, remote syslog), performs fault isolation, provides remote console access.</p> <p>Note that all patching/updating of Oracle Database Appliance is done with the regular Oracle Database Appliance Patch Set Bundle. This includes BIOS and SP firmware. This ensures that all software and firmware component versions are supported to work together. Patches are available through My Oracle Support.</p>	<p>Refer to the appropriate Oracle Integrated Lights Out Manager (ILOM) Documentation Library based on your appliance's supported version of Oracle ILOM.</p> <p><a href="#">Oracle Integrated Lights Out (ILOM) Documentation Library</a></p>
System indicators and LEDs	Provides at-a-glance status of the system and its components.	<ul style="list-style-type: none"> <li>• <a href="#">Overview of System Status Indicators and LEDs</a> (page 1-1)</li> <li>• You can also use Oracle ILOM to check server node indicator status. Refer to the appropriate Oracle Integrated Lights Out Manager (ILOM) Documentation Library based on your appliance's supported version of Oracle ILOM.</li> </ul> <p><a href="#">Oracle Integrated Lights Out (ILOM) Documentation Library</a></p>
Power-On Self-Test (POST)	Tests core components of system: CPUs, memory, and motherboard I/O bridge integrated circuits.	<p>For Oracle Database Appliance X3-2/X4-2/X5-2 and X6-2 series, refer to the appropriate <i>Oracle x86 Servers Diagnostics Guide</i> based on your appliance's supported version of Oracle ILOM.</p> <p><a href="#">Oracle x86 Servers Administration, Diagnostics, and Applications Library</a></p> <p>For the Oracle Database Appliance Version 1, see:</p> <ul style="list-style-type: none"> <li>• <a href="#">Default BIOS Power-On Self-Test (POST) Events</a> (page A-102)</li> <li>• <a href="#">BIOS POST F1 and F2 Errors</a> (page A-104)</li> </ul>
UEFI Diagnostics (for Oracle Database Appliance X4-2/X5-2 and X6 and X7 series)	UEFI-based utility that tests and detect problems on all processor, memory, disk drives, and network ports. It is used on newer Oracle systems.	<p>Refer to the appropriate <i>Oracle x86 Servers Diagnostics Guide</i> based on your appliance's supported version of Oracle ILOM.</p> <p><a href="#">Oracle x86 Servers Administration, Diagnostics, and Applications Library</a></p>

Diagnostic Tool	What It Does	Where to Find Information
Pc-Check (for Oracle Database Appliance X3-2 and Oracle Database Appliance Version 1)	DOS-based utility that tests all motherboard components (CPU, memory, and I/O), ports, and slots.	Refer to the appropriate <i>Oracle x86 Servers Diagnostics Guide</i> based on your appliance's supported version of Oracle ILOM. <a href="#">Oracle x86 Servers Administration, Diagnostics, and Applications Library</a>

## 7.2 Resetting the Service Processor

How to reset the service processor (SP) of a server node of an Oracle Database Appliance.

There are times when you might need to reset the service processor (such as after a firmware update). You can reset the server node SP using Oracle ILOM without affecting the host OS. However, this action disconnects your current Oracle ILOM session and will not allow any new sessions to be initiated until the reset has completed.

To reset the SP using the Oracle ILOM web interface or the CLI, see *Oracle Integrated Lights Out Manager (ILOM) Documentation Library*:

<http://www.oracle.com/goto/ilom/docs>

### Note:

Be sure to refer to the documentation that applies to the version of Oracle ILOM supported with your appliance. See the "Supported Components and Capabilities" section in the *Oracle Database Appliance Owner's Guide*.

If you are unable to reset the SP using the Oracle ILOM web interface or the CLI (for example, if the SP hangs), then use the SP reset button as described in the following tables.

### Note:

The links in the following tables take you to instructions **outside** of the Oracle Database Appliance library. Use your browser's Back button to return to the Oracle Database Appliance library.

### For Oracle Database Appliance X7-2 series:

Oracle Database Appliance X7-2S/X7-2M	Oracle Database Appliance X7-2-HA
<a href="#">Reset the Service Processor From the Server Back Panel</a>	<a href="#">Reset the Service Processor From the Server Back Panel</a>

**For Oracle Database Appliance X6-2 series:**

Oracle Database Appliance X6-2S/X6-2M	Oracle Database Appliance X6-2L	Oracle Database Appliance X6-2-HA
<a href="#">Reset the Service Processor From the Server Back Panel</a>	<a href="#">Reset the Service Processor From the Server Back Panel</a>	<a href="#">Reset the Service Processor From the Server Back Panel</a>

**For Oracle Database Appliance X3-2X4-2/X5-2 and Oracle Database Appliance Version 1:**

Oracle Database Appliance Version 1	Oracle Database Appliance X3-2	Oracle Database Appliance X4-2	Oracle Database Appliance X5-2
<p>1. Find the SP reset button on the rear of the system, next to the power supply and the Locate button/LED.</p> <p>See the "Oracle Database Appliance Version 1 Back Panel" section in the <i>Oracle Database Appliance Owner's Guide</i>.</p> <p>2. Insert a small stylus or non-conductive object into the opening and press the recessed push button switch.</p> <p>The SP resets.</p>	<a href="#">Reset the Service Processor From the Server Back Panel</a>	<a href="#">Reset the Service Processor From the Server Back Panel</a>	<a href="#">Reset the Service Processor From the Server Back Panel</a>

# 8

## Server Node Basic Input/Output System (BIOS)

Learn about the server node BIOS Setup Utility.

The Basic Input/Output System (BIOS) has a Setup Utility stored in the BIOS flash memory. The Setup Utility reports system information and can be used to configure the BIOS settings. The configurable data is provided with context-sensitive help and is stored in the system's battery-backed CMOS RAM. If the configuration stored in the CMOS RAM is invalid, the BIOS settings return to their default optimal values.

### Note:

The BIOS menus shown in this chapter are examples. The BIOS version numbers, menu information, and menu selections are subject to change over the life of the product. You should not change the factory settings unless prompted to do so by Oracle Service personnel.

- [Oracle Database Appliance X7-2 Series BIOS Utility](#) (page 8-1)  
This section describes BIOS Setup Utility for an Oracle Database Appliance X7-2 series system.
- [Oracle Database Appliance X6-2 Series BIOS Utility](#) (page 8-3)  
This section describes BIOS Setup Utility for an Oracle Database Appliance X6-2 series system.
- [Oracle Database Appliance X3-2/X4-2/X5-2 BIOS Utility](#) (page 8-4)  
This section describes BIOS Setup Utility for an Oracle Database Appliance X3-2/X4-2/X5-2 system.
- [Oracle Database Appliance Version 1 BIOS Utility](#) (page 8-6)  
This section describes BIOS Setup Utility for an Oracle Database Appliance Version 1 system.

### 8.1 Oracle Database Appliance X7-2 Series BIOS Utility

This section describes BIOS Setup Utility for an Oracle Database Appliance X7-2 series system.

If you have Oracle Database Appliance X6-2 series, go to [Oracle Database Appliance X6-2 Series BIOS Utility](#) (page 8-3). If you have the Oracle Database Appliance X3-2/X4-2/X5-2, go to [Oracle Database Appliance X3-2/X4-2/X5-2 BIOS Utility](#) (page 8-4). If you have Oracle Database Appliance Version 1, go to [Oracle Database Appliance Version 1 BIOS Utility](#) (page 8-6).

All settings are set to the optimal defaults at startup.



 **Caution:**

You should not configure system BIOS settings. Oracle Database Appliance patch software will do this for you. The only time you might need to configure BIOS settings would be if requested to do so by Oracle Service.

The following topics are included:

- [Setting Up BIOS Configuration Parameters](#) (page 8-2)  
Learn about the BIOS configuration parameters for Oracle Database Appliance X7-2 series.
- [BIOS Setup Utility Menu Options](#) (page 8-2)  
Learn about the BIOS utility menu options for Oracle Database Appliance X7-2 series.

## 8.1.1 Setting Up BIOS Configuration Parameters

Learn about the BIOS configuration parameters for Oracle Database Appliance X7-2 series.

 **Note:**

The links in the following table take you to instructions **outside** of the Oracle Database Appliance library to the Oracle Server X7-2 documentation library. Use your browser's Back button to return to the Oracle Database Appliance library.

Oracle Database Appliance X7-2S/X7-2M	Oracle Database Appliance X7-2-HA
<a href="#">Managing the BIOS Configuration</a>	<a href="#">Managing the BIOS Configuration</a>
<a href="#">Accessing the BIOS Setup Utility</a>	<a href="#">Accessing the BIOS Setup Utility</a>
<a href="#">Using UEFI BIOS</a>	<a href="#">Using UEFI BIOS</a>
<a href="#">Common BIOS Setup Utility Tasks</a>	<a href="#">Common BIOS Setup Utility Tasks</a>

## 8.1.2 BIOS Setup Utility Menu Options

Learn about the BIOS utility menu options for Oracle Database Appliance X7-2 series.

 **Note:**

The links in the following table take you to instructions **outside** of the Oracle Database Appliance library to the Oracle Server X7-2 documentation library. Use your browser's Back button to return to the Oracle Database Appliance library.

Oracle Database Appliance X7-2S/X7-2M	Oracle Database Appliance X7-2-HA
<a href="#">BIOS Main Menu Selections</a>	<a href="#">BIOS Main Menu Selections</a>
<a href="#">BIOS Advanced Menu Selections</a>	<a href="#">BIOS Advanced Menu Selections</a>
<a href="#">BIOS IO Menu Selections</a>	<a href="#">BIOS IO Menu Selections</a>
<a href="#">BIOS Boot Menu Selections</a>	<a href="#">BIOS Boot Menu Selections</a>
<a href="#">BIOS Save and Exit Menu Selections</a>	<a href="#">BIOS Save and Exit Menu Selections</a>

## 8.2 Oracle Database Appliance X6-2 Series BIOS Utility

This section describes BIOS Setup Utility for an Oracle Database Appliance X6-2 series system.

If you have Oracle Database Appliance X7-2 series, go to [Oracle Database Appliance X7-2 Series BIOS Utility](#) (page 8-1). If you have the Oracle Database Appliance X3-2/X4-2/X5-2, go to [Oracle Database Appliance X3-2/X4-2/X5-2 BIOS Utility](#) (page 8-4). If you have Oracle Database Appliance Version 1, go to [Oracle Database Appliance Version 1 BIOS Utility](#) (page 8-6).

All settings are set to the optimal defaults at startup.

### Caution:

You should not configure system BIOS settings. Oracle Database Appliance patch software will do this for you. The only time you might need to configure BIOS settings would be if requested to do so by Oracle Service.

The following topics are included:

- [Setting Up BIOS Configuration Parameters](#) (page 8-3)  
Learn about the BIOS configuration parameters for Oracle Database Appliance X6-2 series.
- [BIOS Setup Utility Menu Options](#) (page 8-4)  
Learn about the BIOS utility menu options for Oracle Database Appliance X6-2 series.

### 8.2.1 Setting Up BIOS Configuration Parameters

Learn about the BIOS configuration parameters for Oracle Database Appliance X6-2 series.

### Note:

The links in the following table take you to instructions **outside** of the Oracle Database Appliance library to the Oracle Server X6-2 and Oracle Server X6-2L documentation libraries. Use your browser's Back button to return to the Oracle Database Appliance library.

Oracle Database Appliance X6-2S/X6-2M	Oracle Database Appliance X6-2L	Oracle Database Appliance X6-2-HA
<a href="#">Managing the BIOS Configuration</a>	<a href="#">Managing the BIOS Configuration</a>	<a href="#">Managing the BIOS Configuration</a>
<a href="#">Accessing the BIOS Setup Utility</a>	<a href="#">Accessing the BIOS Setup Utility</a>	<a href="#">Accessing the BIOS Setup Utility</a>
<a href="#">Using Legacy or UEFI BIOS</a>	<a href="#">Using Legacy or UEFI BIOS</a>	<a href="#">Using Legacy or UEFI BIOS</a>
<a href="#">Using BIOS for Resource Allocation</a>	<a href="#">Using BIOS for Resource Allocation</a>	<a href="#">Using BIOS for Resource Allocation</a>
<a href="#">Common BIOS Setup Utility Tasks</a>	<a href="#">Common BIOS Setup Utility Tasks</a>	<a href="#">Common BIOS Setup Utility Tasks</a>

## 8.2.2 BIOS Setup Utility Menu Options

Learn about the BIOS utility menu options for Oracle Database Appliance X6-2 series.

 **Note:**

The links in the following table take you to instructions **outside** of the Oracle Database Appliance library to the Oracle Server X6-2 and Oracle Server X6-2L documentation libraries. Use your browser's Back button to return to the Oracle Database Appliance library.

Oracle Database Appliance X6-2S/X6-2M	Oracle Database Appliance X6-2L	Oracle Database Appliance X6-2-HA
<a href="#">BIOS Main Menu Selections</a>	<a href="#">BIOS Main Menu Selections</a>	<a href="#">BIOS Main Menu Selections</a>
<a href="#">BIOS Advanced Menu Selections</a>	<a href="#">BIOS Advanced Menu Selections</a>	<a href="#">BIOS Advanced Menu Selections</a>
<a href="#">BIOS IO Menu Selections</a>	<a href="#">BIOS IO Menu Selections</a>	<a href="#">BIOS IO Menu Selections</a>
<a href="#">BIOS Boot Menu Selections</a>	<a href="#">BIOS Boot Menu Selections</a>	<a href="#">BIOS Boot Menu Selections</a>
<a href="#">BIOS Save and Exit Menu Selections</a>	<a href="#">BIOS Save and Exit Menu Selections</a>	<a href="#">BIOS Save and Exit Menu Selections</a>

## 8.3 Oracle Database Appliance X3-2/X4-2/X5-2 BIOS Utility

This section describes BIOS Setup Utility for an Oracle Database Appliance X3-2/X4-2/X5-2 system.

If you have Oracle Database Appliance X7-2 series, go to [Oracle Database Appliance X7-2 Series BIOS Utility](#) (page 8-1). If you have the Oracle Database Appliance X6-2 series, go to [Oracle Database Appliance X6-2 Series BIOS Utility](#) (page 8-3). If you have Oracle Database Appliance Version 1, go to [Oracle Database Appliance Version 1 BIOS Utility](#) (page 8-6).

All settings are set to the optimal defaults at startup.

 **Caution:**

You should not configure system BIOS settings. Oracle Database Appliance patch software will do this for you. The only time you might need to configure BIOS settings would be if requested to do so by Oracle Service.

The following topics are included:

- [Setting Up BIOS Configuration Parameters](#) (page 8-5)  
Learn about the BIOS configuration parameters for Oracle Database Appliance X3-2/X4-2/X5-2.
- [BIOS Setup Utility Menu Options](#) (page 8-5)  
Learn about the BIOS utility menu options for Oracle Database Appliance X3-2/X4-2/X5-2.

### 8.3.1 Setting Up BIOS Configuration Parameters

Learn about the BIOS configuration parameters for Oracle Database Appliance X3-2/X4-2/X5-2.

 **Note:**

The links in the following table take you to instructions **outside** of the Oracle Database Appliance library to the Sun Server X3-2, Sun Server X4-2, and Oracle Server X5-2 documentation libraries. Use your browser's Back button to return to the Oracle Database Appliance library.

Oracle Database Appliance X3-2	Oracle Database Appliance X4-2	Oracle Database Appliance X5-2
<a href="#">Managing the BIOS Configuration</a>	<a href="#">Managing the BIOS Configuration</a>	<a href="#">Managing the BIOS Configuration</a>
<a href="#">Accessing the BIOS Setup Utility</a>	<a href="#">Accessing the BIOS Setup Utility</a>	<a href="#">Accessing the BIOS Setup Utility</a>
<a href="#">Using Legacy or UEFI BIOS</a>	<a href="#">Using Legacy or UEFI BIOS</a>	<a href="#">Using Legacy or UEFI BIOS</a>
<a href="#">Using BIOS for Resource Allocation</a>	<a href="#">Using BIOS for Resource Allocation</a>	<a href="#">Using BIOS for Resource Allocation</a>
<a href="#">Common BIOS Setup Utility Tasks</a>	<a href="#">Common BIOS Setup Utility Tasks</a>	<a href="#">Common BIOS Setup Utility Tasks</a>

### 8.3.2 BIOS Setup Utility Menu Options

Learn about the BIOS utility menu options for Oracle Database Appliance X3-2/X4-2/X5-2.



**Note:**

The links in the following table take you to instructions **outside** of the Oracle Database Appliance library to the Sun Server X3-2, Sun Server X4-2, and Oracle Server X5-2 documentation libraries. Use your browser's Back button to return to the Oracle Database Appliance library.

Oracle Database Appliance X3-2	Oracle Database Appliance X4-2	Oracle Database Appliance X5-2
<a href="#">BIOS Main Menu Selections</a>	<a href="#">BIOS Main Menu Selections</a>	<a href="#">BIOS Main Menu Selections</a>
<a href="#">BIOS Advanced Menu Selections</a>	<a href="#">BIOS Advanced Menu Selections</a>	<a href="#">BIOS Advanced Menu Selections</a>
<a href="#">BIOS IO Menu Selections</a>	<a href="#">BIOS IO Menu Selections</a>	<a href="#">BIOS IO Menu Selections</a>
<a href="#">BIOS Boot Menu Selections</a>	<a href="#">BIOS Boot Menu Selections</a>	<a href="#">BIOS Boot Menu Selections</a>
<a href="#">UEFI Driver Control Menu Selections</a>	<a href="#">UEFI Driver Control Menu Selections</a>	<i>See the Advanced Menu for driver settings.</i>
<a href="#">BIOS Save and Exit Menu Selections</a>	<a href="#">BIOS Save and Exit Menu Selections</a>	<a href="#">BIOS Save and Exit Menu Selections</a>

## 8.4 Oracle Database Appliance Version 1 BIOS Utility

This section describes BIOS Setup Utility for an Oracle Database Appliance Version 1 system.

If you have Oracle Database Appliance X7-2 series, go to [Oracle Database Appliance X7-2 Series BIOS Utility](#) (page 8-1). If you have the Oracle Database Appliance X6-2 series, go to [Oracle Database Appliance X6-2 Series BIOS Utility](#) (page 8-3). If you have Oracle Database Appliance X3-2/X4-2/X5-2, go to [Oracle Database Appliance X3-2/X4-2/X5-2 BIOS Utility](#) (page 8-4).

All settings are set to the optimal defaults at startup.



**Caution:**

You should not configure system BIOS settings. Oracle Database Appliance patch software will do this for you. The only time you might need to configure BIOS settings would be if requested to do so by Oracle Service.

The following topics are included:

- [BIOS Booting and Setup](#) (page A-102)
- [Configuring Support for TPM](#) (page A-110)
- [Configuring SP LAN Settings](#) (page A-115)
- [Configuring Option ROM Settings in BIOS](#) (page A-117)
- [BIOS Setup Utility Hot Keys](#) (page A-118)

- [Accessing the BIOS Setup Utility Menus](#) (page A-119)
- [BIOS Setup Utility Screens](#) (page A-122)

# A

## Servicing the Oracle Database Appliance Version 1

Perform tasks for servicing an Oracle Database Appliance Version 1 (also referred to as "original version" or "V1").

### Note:

Information in this appendix does NOT apply to Oracle Database Appliance X7 series, Oracle Database Appliance X6 series, or Oracle Database Appliance X3-2/X4-2/X5-2. Refer to the preceding chapters in this document for information on servicing those systems.

- [Preparing Oracle Database Appliance Version 1 for Service](#) (page A-1)  
This section describes how to prepare the Oracle Database Appliance Version 1 for service.
- [Servicing Hot-Pluggable Components](#) (page A-14)  
Perform tasks to service hot plug components in an Oracle Database Appliance Version 1 system.
- [Servicing CRUs That Require Server Node Power Off](#) (page A-28)  
Perform tasks for servicing customer-replaceable units (CRUs) for the Oracle Database Appliance Version 1 that require you to power off the server node.
- [Servicing FRUs](#) (page A-51)  
Perform tasks for servicing field-replaceable units (FRUs) for the Oracle Database Appliance Version 1 that require you to power off the system and/or server node.
- [Returning the Appliance to Operation](#) (page A-94)  
Perform tasks for returning the Oracle Database Appliance Version 1 to operation after servicing.
- [Server Node Basic Input/Output System \(BIOS\)](#) (page A-101)  
Learn about the Oracle Database Appliance Version 1 BIOS.

### A.1 Preparing Oracle Database Appliance Version 1 for Service

This section describes how to prepare the Oracle Database Appliance Version 1 for service.

If you have Oracle Database X7-2 series, go to [Preparing Oracle Database Appliance X7-2 Series for Service](#) (page 2-1). If you have Oracle Database X6-2 series, go to [Preparing Oracle Database Appliance X6-2 Series for Service](#) (page 2-2). If you have Oracle Database X3-2/X4-2/X5-2, go to [Preparing Oracle Database Appliance X3-2/X4-2/X5-2 for Service](#) (page 2-3).

- [Component Replacement Policy \(CRUs and FRUs\)](#) (page A-2)  
Listing of CRUs and FRUs for Oracle Database Appliance Version 1.
- [Safety Information](#) (page A-4)  
Learn about important safety information before servicing the Oracle Database Appliance Version 1.
- [Required Tools](#) (page A-4)  
Learn about the tools required to service the Oracle Database Appliance Version 1.
- [Obtaining the Chassis Serial Number](#) (page A-5)  
How to obtain the serial number for the Oracle Database Appliance Version 1.
- [Shutting Down a Server Node and Powering Off the System](#) (page A-5)  
This section describes how to shut down the Oracle Database Appliance Version 1 for servicing.
- [Performing Electrostatic Discharge and Antistatic Prevention Measures](#) (page A-8)  
Learn about ESD and antistatic protection when servicing an Oracle Database Appliance Version 1.
- [Removing Server Nodes From the System Chassis](#) (page A-9)  
Learn about removing an Oracle Database Appliance Version 1 server node from the chassis.
- [Removing the Server Node Top Cover](#) (page A-11)  
Learn about removing the server node top cover for an Oracle Database Appliance Version 1.
- [Removing the Middle Section of the System Top Cover](#) (page A-12)  
Learn about removing the middle section of an Oracle Database Appliance Version 1 server node top cover.

## A.1.1 Component Replacement Policy (CRUs and FRUs)

Listing of CRUs and FRUs for Oracle Database Appliance Version 1.

### Note:

Information in this appendix does NOT apply to Oracle Database Appliance X7 series, Oracle Database Appliance X6 series, or Oracle Database Appliance X3-2/X4-2/X5-2. Refer to the preceding chapters in this document for information on servicing those systems.

The replaceable components in your Oracle Database Appliance Version 1 are designated as either field-replaceable units (FRUs) or customer-replaceable units (CRUs). Some can be replaced with the power on, some require the powering off of a server node, and some require the powering off of the entire system chassis.

- A part designated as a FRU must be replaced by Oracle-qualified service technician.
- A part designated as a CRU can be replaced by a person who is not an Oracle-qualified service technician.



The following table lists replaceable components, their service designation (CRU or FRU), and the system power policy related to servicing the component.

Component	Policy
Storage drives and boot drives (CRU)	Hot-pluggable – Can be removed and replaced when the system is powered on.
Fan modules (CRU)	Hot-pluggable – Can be removed and replaced when the system is powered on.
Power supplies (CRU)	Hot-pluggable – Can be removed and replaced when the system is powered on.
Air duct (FRU)	Cold service, server node – Can only be removed and replaced when the server node is powered off. The other server node and the system chassis can remain on.
DIMMs (CRU)	Cold service, server node – Can only be removed and replaced when the server node is powered off. The other server node and the system chassis can remain on.
PCIe risers (CRU)	Cold service, server node – Can only be removed and replaced when the server node is powered off. The other server node and the system chassis can remain on.
PCIe cards (CRU)	Cold service, server node – Can only be removed and replaced when the server node is powered off. The other server node and the system chassis can remain on.
Boot disk backplane (FRU)	Cold service, server node – Can only be removed and replaced when the server node is powered off. The other server node and the system chassis can remain on.
Server node battery (CRU)	Cold service, server node – Can only be removed and replaced when the server node is powered off. The other server node and the system chassis can remain on.
Processors (CPUs) (FRU)	Cold service, server node – Can only be removed and replaced when the server node is powered off. The other server node and the system chassis can remain on.
Motherboard (FRU)	Cold service, server node – Can only be removed and replaced when the server node is powered off. The other server node and the system chassis can remain on.
Server node internal cables (FRU)	Cold service, server node – Can only be removed and replaced when the server node is powered off. The other server node and the system chassis can remain on.
Power distribution board (FRU)	Cold service, system chassis – Servicing this component requires that the power be completely removed from the system chassis (both server nodes powered off).
Disk midplane module (FRU)	Cold service, system chassis – Servicing this component requires that the power be completely removed from the system chassis (both server nodes powered off).
Disk midplane module HDD cable (FRU)	Cold service, server node – Can only be removed and replaced when the server node is powered off. The other server node and the system chassis can remain on.
Front indicator panels (FRU)	Cold service, system chassis – Servicing this component requires that the power be completely removed from the system chassis (both server nodes powered off).

## A.1.2 Safety Information

Learn about important safety information before servicing the Oracle Database Appliance Version 1.

 **Note:**

Information in this appendix does NOT apply to Oracle Database Appliance X7 series, Oracle Database Appliance X6 series, or Oracle Database Appliance X3-2/X4-2/X5-2. Refer to the preceding chapters in this document for information on servicing those systems.

 **Caution:**

**Hazardous voltage present.** Never run the system with the top cover removed.

 **Caution:**

**Equipment damage.** Install the system top cover properly before starting the system.

For your protection, observe the following safety precautions when setting up your equipment:

- Follow all cautions, warnings, and instructions marked on the equipment and described in *Important Safety Information for Oracle's Hardware Systems* and *Oracle Database Appliance Safety and Compliance Guide*.
- Ensure that the voltage and frequency of your power source match the voltage and frequency inscribed on the equipment's electrical rating label.
- Follow the electrostatic discharge safety practices as described in this chapter.

## A.1.3 Required Tools

Learn about the tools required to service the Oracle Database Appliance Version 1.

 **Note:**

Information in this appendix does NOT apply to Oracle Database Appliance X7 series, Oracle Database Appliance X6 series, or Oracle Database Appliance X3-2/X4-2/X5-2. Refer to the preceding chapters in this document for information on servicing those systems.

- Antistatic wrist strap
- Antistatic mat
- No. 2 10-inch Phillips screwdriver (magnetic tip recommended)
- Flat blade screwdriver
- Stylus or pencil (to press the Clear CMOS button)

## A.1.4 Obtaining the Chassis Serial Number

How to obtain the serial number for the Oracle Database Appliance Version 1.

To obtain support for Oracle Database Appliance Version 1, you need to report your product serial number. The product serial number is located on an RFID tag on the front of the system and on the Customer Information Sheet that is included with the system.

### Note:

Information in this appendix does NOT apply to Oracle Database Appliance X7 series, Oracle Database Appliance X6 series, or Oracle Database Appliance X3-2/X4-2/X5-2. Refer to the preceding chapters in this document for information on servicing those systems.

## A.1.5 Shutting Down a Server Node and Powering Off the System

This section describes how to shut down the Oracle Database Appliance Version 1 for servicing.

### Note:

Information in this appendix does NOT apply to Oracle Database Appliance X7 series, Oracle Database Appliance X6 series, or Oracle Database Appliance X3-2/X4-2/X5-2. Refer to the preceding chapters in this document for information on servicing those systems.

You can shut down either Oracle Database Appliance Version 1 server node using the front panel power button, or Oracle ILOM. Each method provides a **graceful shutdown** and an **emergency shutdown** option.

### Caution:

**Data loss.** To avoid data loss and file system corruption, always use a graceful shutdown unless it is an emergency.

 **Note:**

To use Oracle ILOM to shut down a server node, ensure that you have performed its initial configuration as described in "Connecting and Configuring Oracle ILOM" in the *Oracle Database Appliance Getting Started Guide*.

After you have shut down the server nodes, you can power off the system.

See the following topics in this section to shut down a server node and power off the system chassis:

- [Shut Down a Server Node](#) (page A-6)  
How to shut down an Oracle Database Appliance Version 1 server node.
- [Power Off the System](#) (page A-8)  
How to power off an Oracle Database Appliance Version 1 server node.

### A.1.5.1 Shut Down a Server Node

How to shut down an Oracle Database Appliance Version 1 server node.

You must shut down the server node before you remove it from the system chassis.

 **Note:**

Information in this appendix does NOT apply to Oracle Database Appliance X7 series, Oracle Database Appliance X6 series, or Oracle Database Appliance X3-2/X4-2/X5-2. Refer to the preceding chapters in this document for information on servicing those systems.

1. To shut down a server node using the Power button, perform one of the following:
  - Graceful shutdown: Press and release the recessed Power button on the lower left-hand corner of the server node's front panel (see [1] the following figure). This causes Advanced Configuration and Power Interface (ACPI) to perform an orderly shutdown of the system.
  - Emergency shutdown: Press and hold the recessed Power button on the lower left-hand corner of the server node's front panel for at least five seconds until the main power is off and the server node enters standby power mode (see [1] the following figure).

 **Caution:**

**Data loss.** To avoid data loss and file system corruption, always use a graceful shutdown unless it is an emergency.

When the server node is shut down, the Power/OK LED (see [2] the following figure) on the server node's front panel flashes, indicating that the server node is in standby power mode.

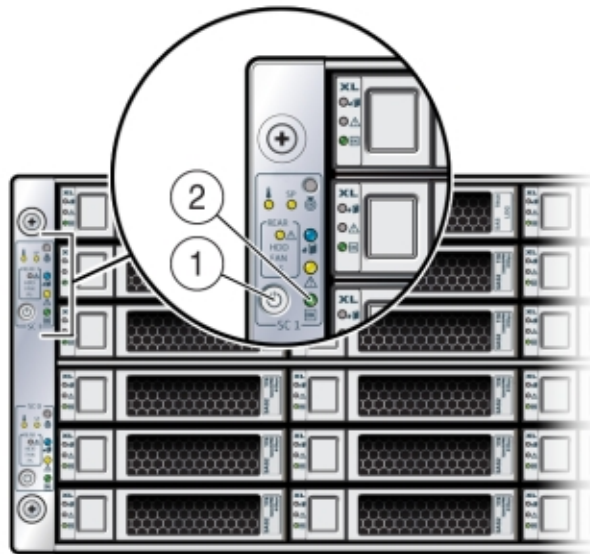

2. To shut down a server node using the Oracle ILOM, perform one of the following:
  - Using the Oracle ILOM web interface:
    - a. Open a browser and enter the server node's service processor IP address in the browser's address field.
    - b. At the log in page, type a user name (the account must have Reset and Host Control (r) privileges) and password, and click the Log In button.
    - c. Go to Remote Power Control and do one of the following:
      - Select **Graceful Shutdown and Power Off** from the Select Action list box and then click Save and OK.  
The server node shuts down gracefully.
      - Select **Immediate Power Off** from the Select Action list box and then click Save and OK.  
The server node shuts down immediately.

**Caution:**

**Data loss.** To avoid data loss and file system corruption, use graceful shutdown unless it is an emergency.

- Using the Oracle ILOM CLI:
  - a. Log in to Oracle ILOM using an ssh client. Type:

```
$ssh username@sp_ip_address
```

Where *username* is a user account name with Reset and Host Control (r) privileges and *sp\_ip\_address* is the IP address of the server node service processor.

- b. When prompted, enter the user account password.
- c. Enter the command to shut down the server node:
  - For a graceful shutdown, type:
 

```
-> stop /SYS
```

The server node shuts down gracefully.
  - For an emergency shutdown, type:
 

```
-> stop -f /SYS
```

The server node shuts down immediately.

 **Caution:**

**Data loss.** To avoid data loss and file system corruption, use graceful shutdown unless it is an emergency.

## A.1.5.2 Power Off the System

How to power off an Oracle Database Appliance Version 1 server node.

The appliance database must be shut down before powering off the entire appliance.

 **Note:**

Information in this appendix does NOT apply to Oracle Database Appliance X7 series, Oracle Database Appliance X6 series, or Oracle Database Appliance X3-2/X4-2/X5-2. Refer to the preceding chapters in this document for information on servicing those systems.

1. Shut down both server nodes.
 

Shutting down both server nodes places the system in standby power mode. See [Shut Down a Server Node](#) (page A-6).
2. Disconnect the AC power cords from the system.
 

Disconnecting the power cords from the system removes all power from the system.

## A.1.6 Performing Electrostatic Discharge and Antistatic Prevention Measures

Learn about ESD and antistatic protection when servicing an Oracle Database Appliance Version 1.

 **Note:**

Information in this appendix does NOT apply to Oracle Database Appliance X7 series, Oracle Database Appliance X6 series, or Oracle Database Appliance X3-2/X4-2/X5-2. Refer to the preceding chapters in this document for information on servicing those systems.

Electrostatic discharge (ESD) sensitive devices, such as the motherboards, PCIe cards, storage drives, and memory cards, require special handling.

 **Caution:**

**Equipment damage.** Follow antistatic precautions and do not touch the components along their connector edges.

When handling components such as storage drive assemblies, circuit boards, or PCIe cards:

- Attach an *antistatic strap* to your wrist and then to a metal area on the chassis. Following this practice equalizes the electrical potential between you and the system.

 **Note:**

An antistatic wrist strap is not included in the system Accessory Kit. However, antistatic wrist straps are included with some options and components.

- Place ESD-sensitive components on an *antistatic mat*. The following items can be used as an antistatic mat:
  - Antistatic bag used to wrap a replacement part
  - ESD mat
  - Disposable ESD mat (shipped with some replacement parts or optional system components)

## A.1.7 Removing Server Nodes From the System Chassis

Learn about removing an Oracle Database Appliance Version 1 server node from the chassis.

 **Note:**

Information in this appendix does NOT apply to Oracle Database Appliance X7 series, Oracle Database Appliance X6 series, or Oracle Database Appliance X3-2/X4-2/X5-2. Refer to the preceding chapters in this document for information on servicing those systems.

You must remove the Oracle Database Appliance Version 1 server node from the chassis to remove or replace internal server node components.

- [Remove a Server Node From the System Chassis](#) (page A-10)  
How to remove an Oracle Database Appliance Version 1 server node from the chassis.

### A.1.7.1 Remove a Server Node From the System Chassis

How to remove an Oracle Database Appliance Version 1 server node from the chassis.

 **Note:**

Information in this appendix does NOT apply to Oracle Database Appliance X7 series, Oracle Database Appliance X6 series, or Oracle Database Appliance X3-2/X4-2/X5-2. Refer to the preceding chapters in this document for information on servicing those systems.

The removal procedure is the same for both server nodes. Note that you do not need to remove the entire system chassis from the rack to perform service procedures on a server node.

 **Note:**

Replacing a server node FRU with a new server node is a service activity that must be performed by an Oracle-qualified service technician. The customer may remove the server node to service other CRU components in the server node.

1. Shut down the server node.  
See [Shut Down a Server Node](#) (page A-6).

 **Caution:**

**Data loss.** To avoid data loss and file system corruption, always use a graceful shutdown unless it is an emergency.



2. To unseat the server node from the system chassis, pull the two latches on the rear of the server node down [1] as shown in the following figure.  
The latches are marked by green tabs. Pull the latches down and away from the rear to the system.

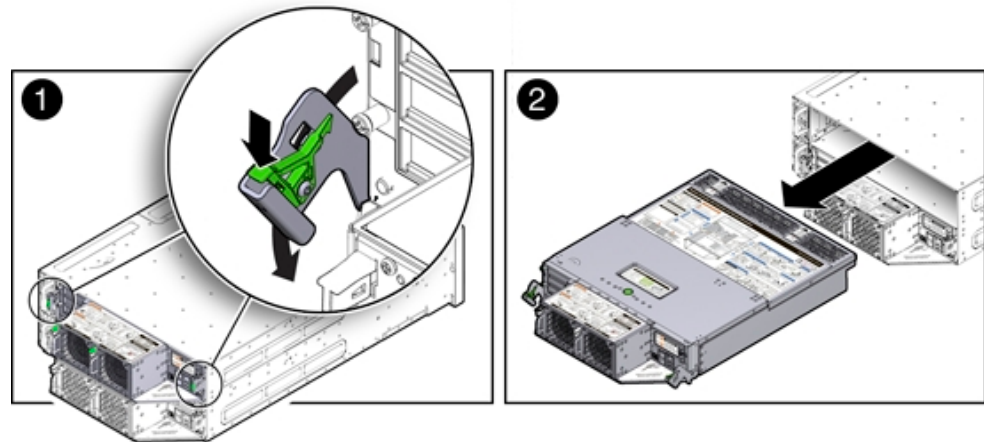

3. Slide the server node to the rear and lift it out of the system [2] as shown in the previous figure.

## A.1.8 Removing the Server Node Top Cover

Learn about removing the server node top cover for an Oracle Database Appliance Version 1.

### Note:

Information in this appendix does NOT apply to Oracle Database Appliance X7 series, Oracle Database Appliance X6 series, or Oracle Database Appliance X3-2/X4-2/X5-2. Refer to the preceding chapters in this document for information on servicing those systems.

To gain access to a most of Oracle Database Appliance Version 1 server node's internal components, you must remove the server node's top cover.

- [Remove the Server Node Top Cover](#) (page A-12)  
How to remove an Oracle Database Appliance Version 1 server node top cover.

## A.1.8.1 Remove the Server Node Top Cover

How to remove an Oracle Database Appliance Version 1 server node top cover.

 **Note:**

Information in this appendix does NOT apply to Oracle Database Appliance X7 series, Oracle Database Appliance X6 series, or Oracle Database Appliance X3-2/X4-2/X5-2. Refer to the preceding chapters in this document for information on servicing those systems.

1. Remove the server node from the system chassis.  
 See [Shut Down a Server Node](#) (page A-6).
2. Remove the top cover.
  - a. To unlatch the server node top cover, press and hold the green release button on the top of the server node cover [1].
  - b. Using the indented area near the green release button, slide the cover toward the front of the server node about 0.5 inches (12.7 mm) [1] as shown in the following figure.
  - c. Lift the cover up and remove it [2] as shown in the following figure.

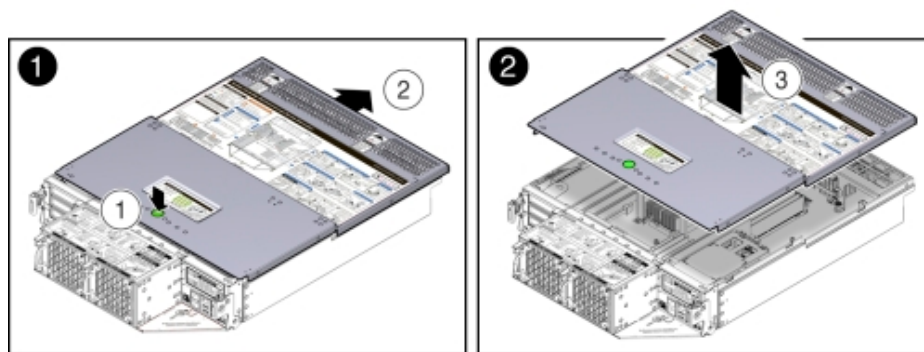

## A.1.9 Removing the Middle Section of the System Top Cover

Learn about removing the middle section of an Oracle Database Appliance Version 1 server node top cover.

 **Note:**

Information in this appendix does NOT apply to Oracle Database Appliance X7 series, Oracle Database Appliance X6 series, or Oracle Database Appliance X3-2/X4-2/X5-2. Refer to the preceding chapters in this document for information on servicing those systems.

To gain access to the Oracle Database Appliance Version 1 power distribution board and the disk midplane board you must remove the middle section of the system's top cover.

- [Remove the Middle Section of System Top Cover](#) (page A-13)  
How to remove an Oracle Database Appliance Version 1 server node top cover middle section.

### A.1.9.1 Remove the Middle Section of System Top Cover

How to remove an Oracle Database Appliance Version 1 server node top cover middle section.

 **Note:**

Information in this appendix does NOT apply to Oracle Database Appliance X7 series, Oracle Database Appliance X6 series, or Oracle Database Appliance X3-2/X4-2/X5-2. Refer to the preceding chapters in this document for information on servicing those systems.

1. Power down the server nodes and remove the power cords from the power supplies.

For instructions, see [Shut Down a Server Node](#) (page A-6).

 **Caution:**

**System fault.** Do not remove the middle section of the system cover while the AC power cords are connected. Otherwise the fault LEDs light and a system fault is logged.

2. Remove the middle section of the system top cover.

To remove the middle section of the system's top cover, remove the captive Phillips screws that secure it to the system as shown in the following figure.

 **Caution:**

**Hazardous voltage present.** Never run the system with the middle section of the system top cover removed.

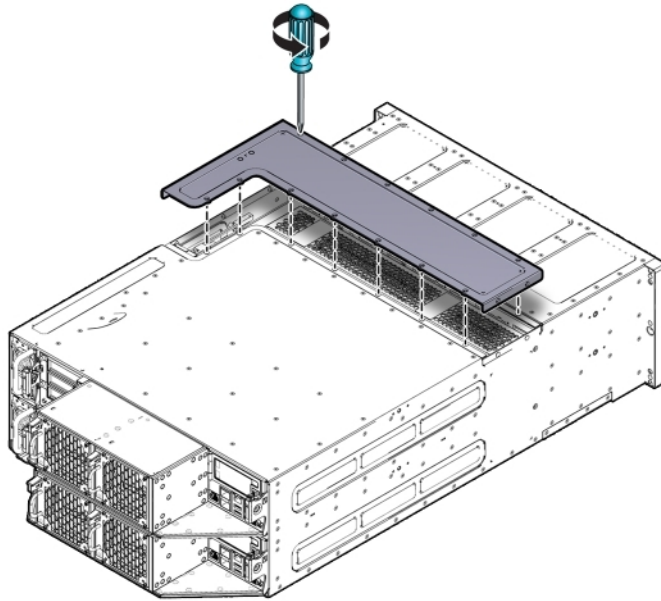

## A.2 Servicing Hot-Pluggable Components

Perform tasks to service hot plug components in an Oracle Database Appliance Version 1 system.

### Note:

Information in this appendix does NOT apply to Oracle Database Appliance X7 series, Oracle Database Appliance X6 series, or Oracle Database Appliance X3-2/X4-2/X5-2. Refer to the preceding chapters in this document for information on servicing those systems.

- After a physical insertion or removal action of a storage component (such as a disk or SAS cable), you should wait before performing the next action to allow the system software to fully process the event. This could take up to 3 minutes to complete.
- For the Oracle Database Appliance Version 1, you must run the `oakcli add disk -local` command after replacing a failed disk. Refer to the *Administration and Reference Guide* for details.
- [Servicing Storage Drives and Boot Drives \(CRU\)](#) (page A-15)  
Learn about servicing Oracle Database Appliance Version 1 system storage and boot drives.
- [Servicing Fan Modules \(CRU\)](#) (page A-22)  
Perform tasks for servicing system chassis fan modules in an Oracle Database Appliance Version 1.
- [Servicing Power Supplies \(CRU\)](#) (page A-25)  
Perform tasks for servicing system chassis power supplies in an Oracle Database Appliance Version 1.

## A.2.1 Servicing Storage Drives and Boot Drives (CRU)

Learn about servicing Oracle Database Appliance Version 1 system storage and boot drives.

### Note:

Information in this appendix does NOT apply to Oracle Database Appliance X7 series, Oracle Database Appliance X6 series, or Oracle Database Appliance X3-2/X4-2/X5-2. Refer to the preceding chapters in this document for information on servicing those systems.

Oracle Database Appliance Version 1 has 24 storage drives, located in the front of the chassis, and each server node has 2 boot drives, located in the rear. All storage drives and boot drives are hot-pluggable.

- [Storage and Boot Drive Locations](#) (page A-15)  
Learn about storage and boot drive locations.
- [Remove a Storage Drive](#) (page A-17)  
How to remove a storage drive from an Oracle Database Appliance Version 1 server node.
- [Install a Storage Drive](#) (page A-18)  
How to install a storage drive in an Oracle Database Appliance Version 1 server node.
- [Remove a Boot Drive](#) (page A-20)  
How to remove a boot drive from an Oracle Database Appliance Version 1 server node.
- [Install a Boot Drive](#) (page A-21)  
How to install a boot drive in an Oracle Database Appliance Version 1 server node.

### A.2.1.1 Storage and Boot Drive Locations

Learn about storage and boot drive locations.

**Appliance storage drives.** Appliance storage drives are installed at the front of Oracle Database Appliance Version 1. Drive numbering is listed on the drive label on the right side of the appliance [1] as shown in the following figure.



The following table shows slot numbering and the type of the storage drive supported in each slot.

**Note:**

The appliance might include both mechanical hard disk (HDD) and solid state (SSD) drives. Both use the same 2.5 inch disk drive bracket. An SSD has a smaller footprint inside of the bracket than an HDD.

Drive Slot Numbers and Types Supported	Drive Slot Numbers and Types Supported	Drive Slot Numbers and Types Supported	Drive Slot Numbers and Types Supported
SSD20	SSD21	SSD22	SSD23
HDD16	HDD17	HDD18	HDD19
HDD12	HDD13	HDD14	HDD15
HDD8	HDD9	HDD10	HDD11
HDD4	HDD5	HDD6	HDD7
HDD0	HDD1	HDD2	HDD3

**Server Node boot drives.** Each appliance server node contains two boot drives that are installed in the back of Oracle Database Appliance and identified on the rear drive panel label [1] as shown in the following figure.



The following table shows the location and numbering of the boot drives.

Callout	Drive Locations and Identification
1	Boot Drives at the back of server node 1. Location and identification of the server node 1 boot drives as listed in Oracle ILOM: <ul style="list-style-type: none"><li>• /SYS/MB/RHDD1</li><li>• /SYS/MB/RHDD0</li></ul>
2	Boot Drives at the back of server node 0. Location and identification of the server node 0 boot drives as listed in Oracle ILOM: <ul style="list-style-type: none"><li>• /SYS/MB/RHDD1</li><li>• /SYS/MB/RHDD0</li></ul>

## A.2.1.2 Remove a Storage Drive

How to remove a storage drive from an Oracle Database Appliance Version 1 server node.

### Note:

Information in this appendix does NOT apply to Oracle Database Appliance X7 series, Oracle Database Appliance X6 series, or Oracle Database Appliance X3-2/X4-2/X5-2. Refer to the preceding chapters in this document for information on servicing those systems.

#### 1. Identify the storage drive that you want to remove.

If a drive has failed, its amber Service Required LED will be lit. For information on drive status LEDs, see [Storage and Boot Drive Status Indicators](#) (page 1-47). For specific drive locations, see [Storage and Boot Drive Locations](#) (page A-15).

#### 2. Remove a storage drive.

- a. On the drive you plan to remove, push the storage drive release button to open the latch [1] as shown in the following figure.
- b. Grasp the latch, swing it open 45 degrees until it unlatches the drive from the slot and slowly pull the drive straight out of the drive slot [1 and 2] as shown in the following figure.

Do not bend the latch too far to the right or exert too much force on the latch when removing the drive.

### Caution:

**Equipment damage.** Always replace a drive with another drive to maintain proper airflow.

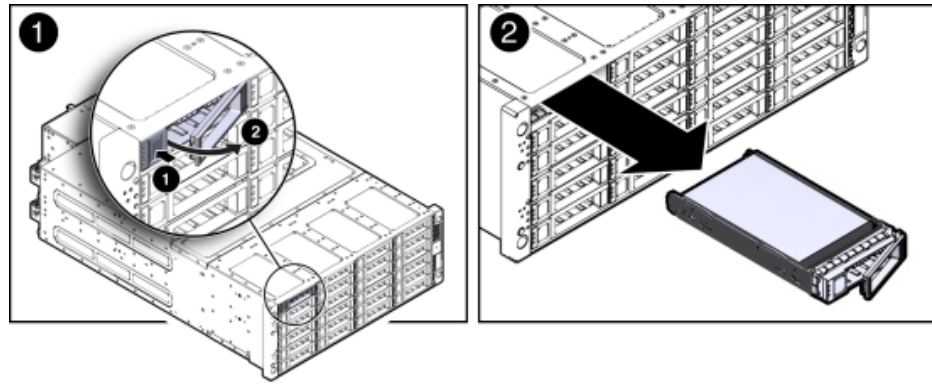

### A.2.1.3 Install a Storage Drive

How to install a storage drive in an Oracle Database Appliance Version 1 server node.

 **Note:**

Information in this appendix does NOT apply to Oracle Database Appliance X7 series, Oracle Database Appliance X6 series, or Oracle Database Appliance X3-2/X4-2/X5-2. Refer to the preceding chapters in this document for information on servicing those systems.

1. Determine the drive slot location for the replacement drive.  
Drives are physically addressed according to the slot in which they are installed. See [Storage and Boot Drive Locations](#) (page A-15) for drive locations.
2. Slide the drive into the drive slot as far as it will go as shown in the following figure.



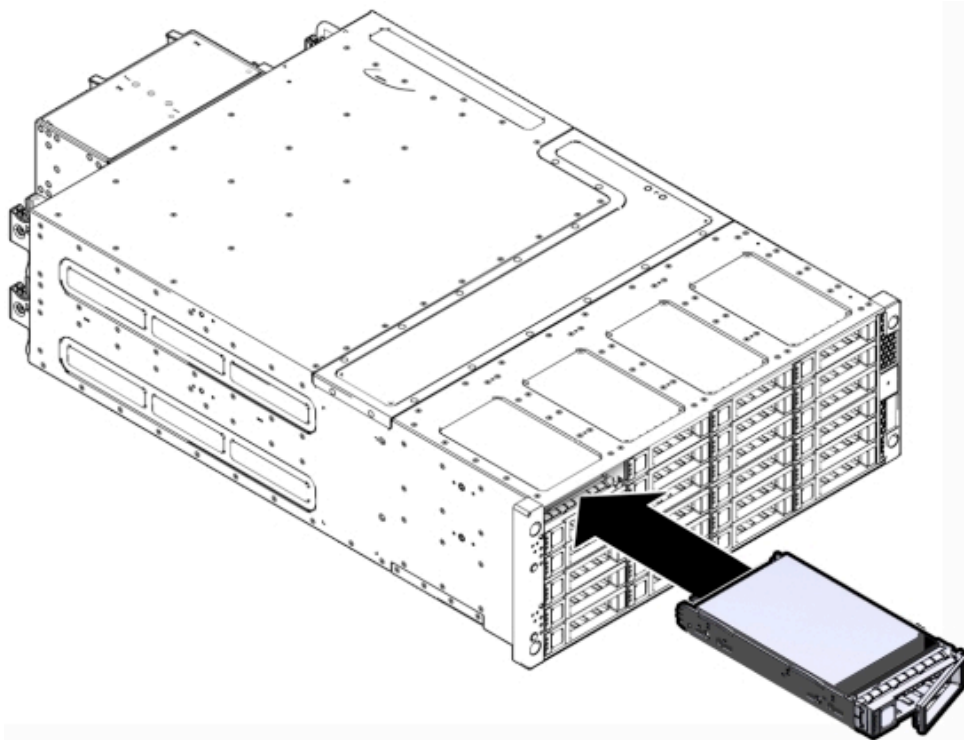

3. Close the latch to lock the drive in place.

 **Note:**

After a physical insertion or removal action of a storage component (such as a disk or SAS cable), you should wait before performing the next action to allow the system software to fully process the event. This could take up to 3 minutes to complete.

4. After replacing a disk, if you have a bare metal deployment of Oracle Database Appliance, make the disk available to the appliance using the `oakcli` command. Type:

```
# oakcli add disk -local
```

 **Note:**

This command is not supported on virtualized configurations.

Refer to the *Administration and Reference Guide* for additional details.

## A.2.1.4 Remove a Boot Drive

How to remove a boot drive from an Oracle Database Appliance Version 1 server node.

 **Note:**

Information in this appendix does NOT apply to Oracle Database Appliance X7 series, Oracle Database Appliance X6 series, or Oracle Database Appliance X3-2/X4-2/X5-2. Refer to the preceding chapters in this document for information on servicing those systems.

1. Identify the boot drive that you want to remove.  
The amber Service Required LED might be lit. For specific drive locations, see [Storage and Boot Drive Locations](#) (page A-15).
2. Remove the boot drive.
  - a. To open the drive door, slide the latch to the left [1] as shown in the following figure.
  - b. Pull the door open and push the storage drive release button to open the latch [2 and 3] as shown in the following figure.
  - c. Grasp the latch, swing it open 45 degrees until it unlatches the drive from the slot and slowly pull the drive straight out of the drive slot [2] as shown in the following figure.

Do not bend the latch too far to the right or exert too much force on the latch when removing the drive.

 **Caution:**

**Equipment damage.** Close the door after removing a boot drive to prevent overheating due to improper airflow.

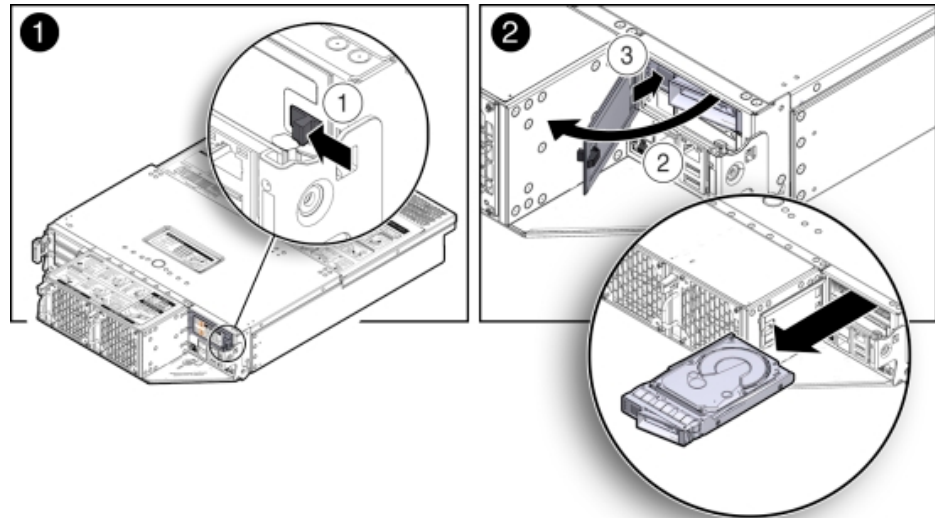

### A.2.1.5 Install a Boot Drive

How to install a boot drive in an Oracle Database Appliance Version 1 server node.

 **Note:**

Information in this appendix does NOT apply to Oracle Database Appliance X7 series, Oracle Database Appliance X6 series, or Oracle Database Appliance X3-2/X4-2/X5-2. Refer to the preceding chapters in this document for information on servicing those systems.

1. Determine the drive slot location for the replacement drive.  
 Drives are physically addressed according to the slot in which they are installed. See [Storage and Boot Drive Locations](#) (page A-15) for drive locations.
2. Pull open the rear drive door.
3. Slide the drive into the drive slot until it is fully seated [1] as shown in the following figure.

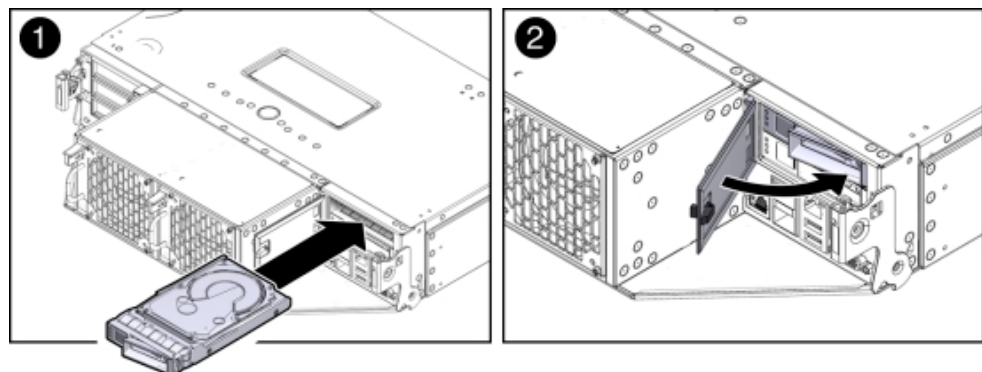

4. Close the drive latch to lock the drive in place.
5. Close the drive door and ensure that the door latch engages [2] as shown in the previous figure.

 **Caution:**

**Equipment damage.** Close the door after removing a boot drive to prevent overheating due to improper airflow.

6. Run the following command to ensure that the OS sees the replacement disk.

```
# ls SCSI -v | grep ATA
[0:0:0:0]diskATA SEAGATE ST95001N n/a /dev/sda
[1:0:0:0]diskATA SEAGATE ST95001N n/a /dev/sdb
```

## A.2.2 Servicing Fan Modules (CRU)

Perform tasks for servicing system chassis fan modules in an Oracle Database Appliance Version 1.

 **Note:**

Information in this appendix does NOT apply to Oracle Database Appliance X7 series, Oracle Database Appliance X6 series, or Oracle Database Appliance X3-2/X4-2/X5-2. Refer to the preceding chapters in this document for information on servicing those systems.

Each Oracle Database Appliance Version 1 server node contains two fan modules. Each fan module contains a single, dual-motor, 80 mm, counter-rotating fan assembly that contains two fans. Each fan module is hot-pluggable. For specific information about fan status LEDs, see [Server Node Fan Status Indicators](#) (page 1-46).

When a server node is removed from the system, the fans provide sufficient cooling for all 24 front disks and the server node. A door automatically closes off the vacant server node slot to ensure proper cooling. When the server node is replaced, its two fans also cool the 24 front disks and provide cooling to the second server node.

 **Caution:**

**Equipment damage.** If a fan module fails, replace it as soon as possible.

- [Detecting a Fan Module Failure](#) (page A-23)  
Learn how to detect a fan module failure in an Oracle Database Appliance Version 1.
- [Remove a Fan Module](#) (page A-23)  
How to remove a fan module in an Oracle Database Appliance Version 1.

- [Install a Fan Module](#) (page A-24)  
How to install a fan module in an Oracle Database Appliance Version 1.

### A.2.2.1 Detecting a Fan Module Failure

Learn how to detect a fan module failure in an Oracle Database Appliance Version 1.

The following LEDs in Oracle Database Appliance Version 1 are lit when a fan module fault is detected:

- Front and rear Service Required LEDs located on each server node
- REAR HDD/PS/FAN LED located on the front of each server node
- Fan Fault Status LED located on the faulty fan module

The system over-temperature LED for a server node might light if a fan fault causes an increase in server node operating temperature. See [Oracle Database Appliance Version 1 Status Indicators](#) (page 1-43) for more information about server node LEDs.

### A.2.2.2 Remove a Fan Module

How to remove a fan module in an Oracle Database Appliance Version 1.

#### Note:

Information in this appendix does NOT apply to Oracle Database Appliance X7 series, Oracle Database Appliance X6 series, or Oracle Database Appliance X3-2/X4-2/X5-2. Refer to the preceding chapters in this document for information on servicing those systems.

This section describes removing a fan module from Oracle Database Appliance Version 1.

#### Caution:

**Equipment damage.** When removing a fan module from a powered on system, it must be replaced within two minutes of removal.

1. Identify the faulty fan module with its amber LED.  
When a fan fails, the Service Required LED lights amber. For information about fan status LEDs, see [Server Node Fan Indicators](#) (page 1-46).
2. To remove the faulty fan module, press down on the fan release lever [1] as shown in the following figure.
3. While holding the release lever down, use the handle on the fan module to pull it out of the server node [2] as shown in the following figure.  
The fan door swings shut to ensure proper cooling.

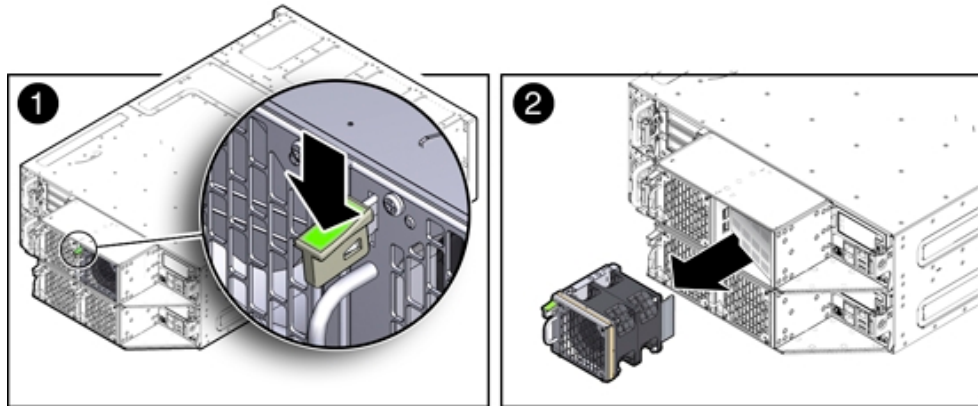

### A.2.2.3 Install a Fan Module

How to install a fan module in an Oracle Database Appliance Version 1.

 **Note:**

Information in this appendix does NOT apply to Oracle Database Appliance X7 series, Oracle Database Appliance X6 series, or Oracle Database Appliance X3-2/X4-2/X5-2. Refer to the preceding chapters in this document for information on servicing those systems.

This section describes installing a fan module from Oracle Database Appliance Version 1.

1. Align the fan module in the fan door and slide it into the server node.  
The extender on the side of the fan module pushes the fan door open, allowing the fan module to enter.
2. Apply firm pressure to fully seat the fan module.  
The fan release lever engages when the fan is fully seated as shown in the following figure.

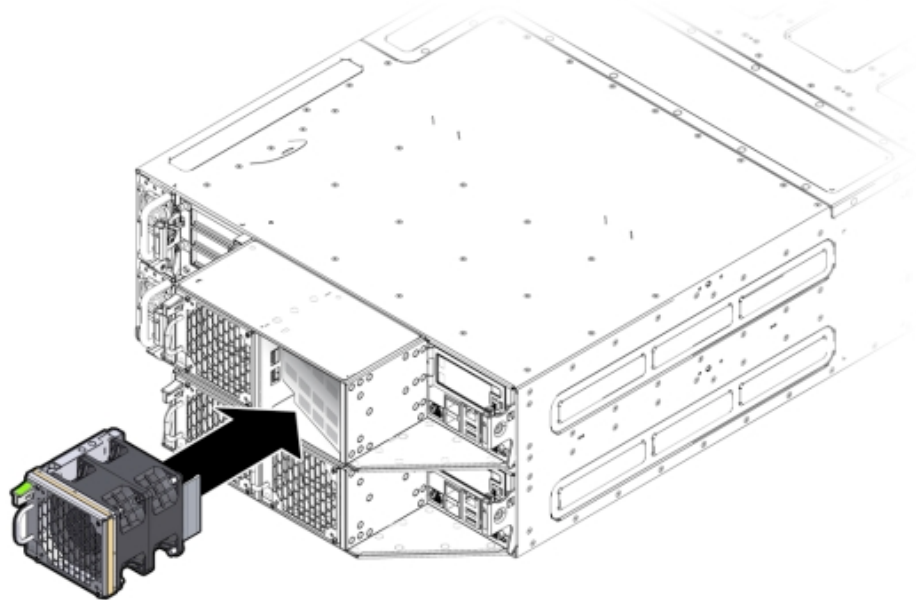

3. Verify that the Fan Fault Status LED on the replacement fan module is lit green.
4. Verify that the following fault LEDs on the applicable server node are off:
  - Front and rear Service Required LEDs located on the applicable server node
  - REAR HDD/PS/FAN LED located on the front of the applicable server node

See [Oracle Database Appliance Version 1 Status Indicators](#) (page 1-43) for more information about system LEDs.

## A.2.3 Servicing Power Supplies (CRU)

Perform tasks for servicing system chassis power supplies in an Oracle Database Appliance Version 1.

### Note:

Information in this appendix does NOT apply to Oracle Database Appliance X7 series, Oracle Database Appliance X6 series, or Oracle Database Appliance X3-2/X4-2/X5-2. Refer to the preceding chapters in this document for information on servicing those systems.

Oracle Database Appliance Version 1 is equipped with two hot pluggable power supplies. They are redundant, meaning that the system can operate with a single power supply. This allows you to remove and replace a power supply without shutting the system down.

If a power supply fails and you do not have a replacement available, to ensure proper airflow, leave the failed power supply installed in the system.

For information about power supply status LEDs, see [Power Supply Status Indicators](#) (page 1-47).

- [Detecting a Power Supply Failure](#) (page A-26)  
Learn how to detect a power supply failure in an Oracle Database Appliance Version 1.
- [Remove a Power Supply](#) (page A-26)  
How to remove a power supply from an Oracle Database Appliance Version 1.
- [Install a Power Supply](#) (page A-27)  
How to install a power supply in an Oracle Database Appliance Version 1.

### A.2.3.1 Detecting a Power Supply Failure

Learn how to detect a power supply failure in an Oracle Database Appliance Version 1.

The following LEDs light up in Oracle Database Appliance Version 1 when the system detects a power supply fault:

- Front and rear Service Required LEDs located on each server node
- REAR HDD/PS/FAN LED located on the front of each server node
- Service Required LED located on the faulty power supply

See [Oracle Database Appliance Version 1 Status Indicators](#) (page 1-43) for more information about these LEDs.

### A.2.3.2 Remove a Power Supply

How to remove a power supply from an Oracle Database Appliance Version 1.

#### **Note:**

Information in this appendix does NOT apply to Oracle Database Appliance X7 series, Oracle Database Appliance X6 series, or Oracle Database Appliance X3-2/X4-2/X5-2. Refer to the preceding chapters in this document for information on servicing those systems.

This section describes removing a Power Supply from Oracle Database Appliance Version 1.

#### **Caution:**

**Hazardous voltages.** To reduce the risk of electric shock and danger to personal health, follow the instructions.

1. Identify which power supply (0 or 1) requires replacement.  
A lit Service Required LED on a power supply indicates that a failure was detected. For information about power supply status LEDs, see [Power Supply Status Indicators](#) (page 1-47).
2. Disconnect the power cord from the faulty power supply.



3. Grasp the power supply handle and press the release latch [1] as shown in the following figure.
4. Pull the power supply out of the chassis [2] as shown in the following figure.

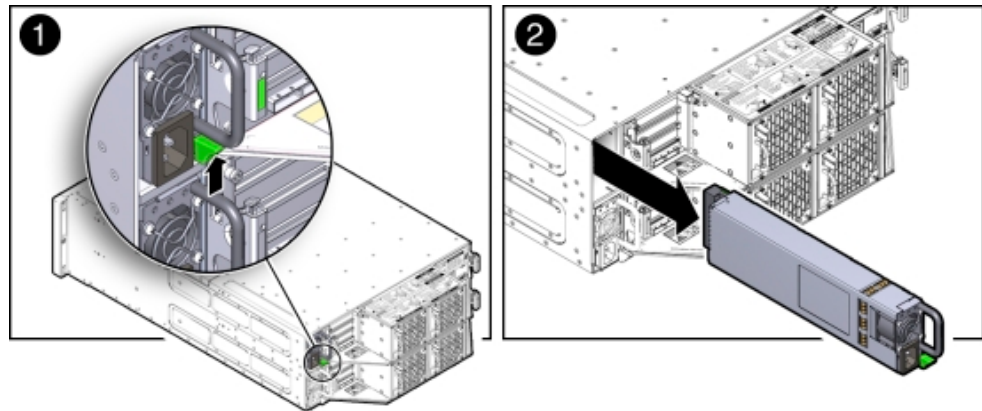

### A.2.3.3 Install a Power Supply

How to install a power supply in an Oracle Database Appliance Version 1.

 **Note:**

Information in this appendix does NOT apply to Oracle Database Appliance X7 series, Oracle Database Appliance X6 series, or Oracle Database Appliance X3-2/X4-2/X5-2. Refer to the preceding chapters in this document for information on servicing those systems.

This section describes removing a Power Supply from Oracle Database Appliance Version 1.

 **Caution:**

**Hazardous voltages.** To reduce the risk of electric shock and danger to personal health, follow the instructions.

1. Align the replacement power supply with the empty power supply chassis bay.
2. Slide the power supply into the bay until it is fully seated as shown in the following figure.

The release latch engages when the power supply is fully seated.

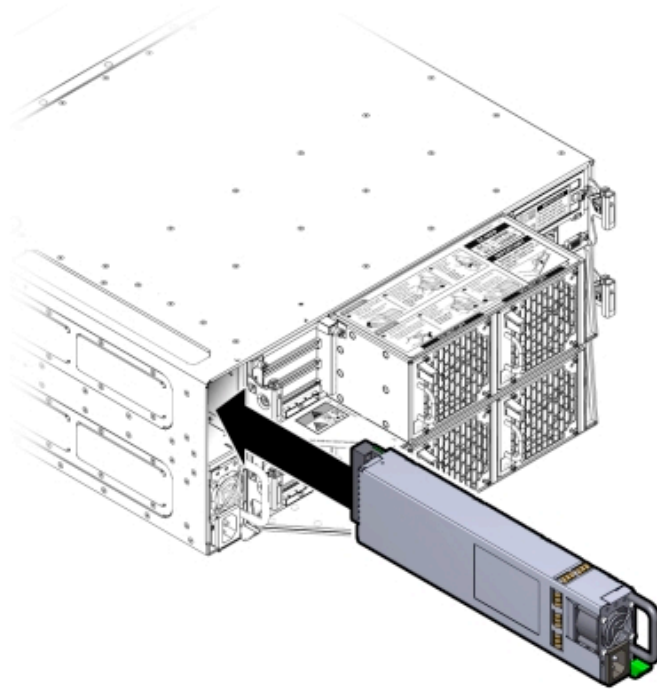

3. Reconnect the power cord to the power supply and verify the following:
  - The power supply AC Present LED is lit
  - The power supply Service Required LED is off.
4. Verify that the following LEDs are off:
  - Service Required LEDs located on the front of both server nodes
  - REAR HDD/PS/FAN LED located on the front of both server nodes

See [Oracle Database Appliance Version 1 Status Indicators](#) (page 1-43) for more information about system LEDs.

## A.3 Servicing CRUs That Require Server Node Power Off

Perform tasks for servicing customer-replaceable units (CRUs) for the Oracle Database Appliance Version 1 that require you to power off the server node.

 **Note:**

Information in this appendix does NOT apply to Oracle Database Appliance X7 series, Oracle Database Appliance X6 series, or Oracle Database Appliance X3-2/X4-2/X5-2. Refer to the preceding chapters in this document for information on servicing those systems.

This section includes information on how to service the following Oracle Database Appliance Version 1 CRUs:

- [Server Node CRU Component Locations](#) (page A-29)  
Learn about customer-replaceable server node components in the Oracle Database Appliance Version 1.
- [Servicing Memory Modules \(DIMMs\) \(CRU\)](#) (page A-30)  
Learn about customer-replaceable server node components in the Oracle Database Appliance Version 1.
- [Servicing PCIe Risers \(CRU\)](#) (page A-37)  
Perform tasks for servicing PCIe risers in the Oracle Database Appliance Version 1.
- [Servicing PCIe Cards \(CRU\)](#) (page A-41)  
Perform tasks for servicing PCIe cards in the Oracle Database Appliance Version 1.
- [Servicing the Server Node Battery \(CRU\)](#) (page A-49)  
Learn about servicing a server node system battery in the Oracle Database Appliance Version 1.

### A.3.1 Server Node CRU Component Locations

Learn about customer-replaceable server node components in the Oracle Database Appliance Version 1.

Each server node (also called a system controller) in Oracle Database Appliance Version 1 includes the replaceable components shown in the following figure.

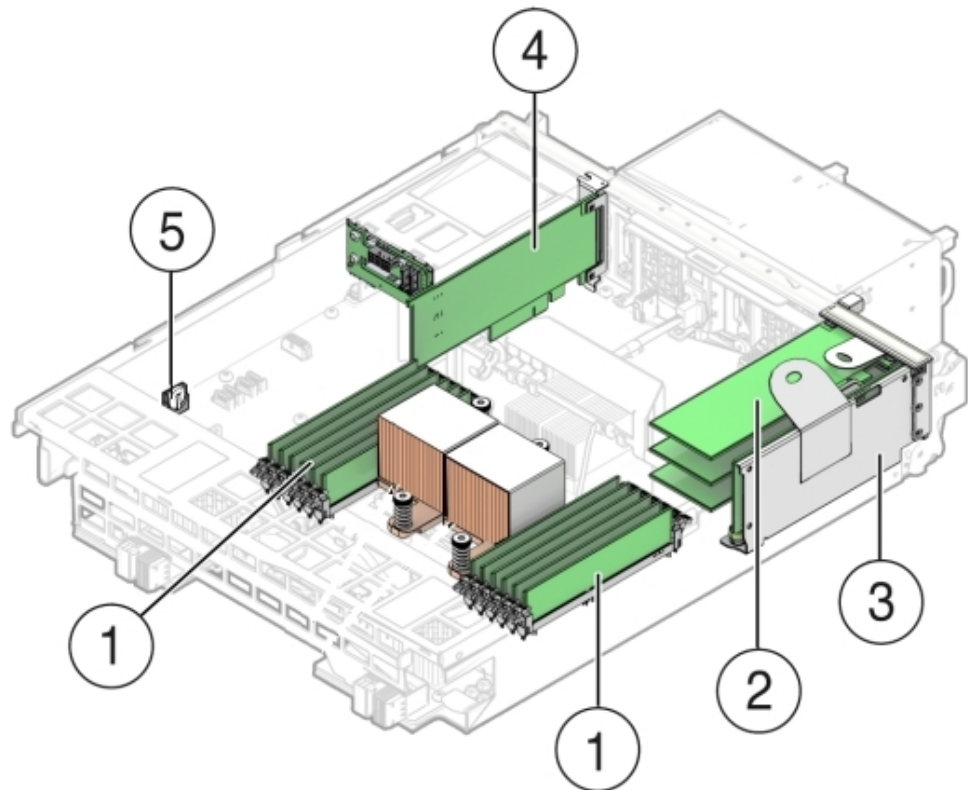

Callout	Description
1	DDR3 Memory DIMMs (12)
2	PCIe Cards Mounted on PCIe Riser
3	PCIe Riser
4	Internal HBA PCIe Card
5	Battery

## A.3.2 Servicing Memory Modules (DIMMs) (CRU)

Learn about customer-replaceable server node components in the Oracle Database Appliance Version 1.



### Note:

Information in this appendix does NOT apply to Oracle Database Appliance X7 series, Oracle Database Appliance X6 series, or Oracle Database Appliance X3-2/X4-2/X5-2. Refer to the preceding chapters in this document for information on servicing those systems.

Each server node in Oracle Database Appliance Version 1 is provisioned with twelve 1333 MHz or 1600 MHz DDR3, 8GB dual rank DIMMs, for a total of 96GB.

The server node supports a maximum memory speed of 1333 MHz, even if 1600 MHz DIMMs are installed.

Before replacing a DIMM see the following:

- [DIMM and CPU Physical Layout](#) (page A-31)  
Learn about DIMM and processor layout in the Oracle Database Appliance Version 1.
- [Remove Faulty DIMMs](#) (page A-32)  
How to remove a DIMM from an Oracle Database Appliance Version 1.
- [Install DIMMs](#) (page A-35)  
How to install a DIMM in an Oracle Database Appliance Version 1.
- [Error Correction and Parity Protection](#) (page A-37)  
Learn about DIMM ECC and parity errors in the Oracle Database Appliance Version 1.

### A.3.2.1 DIMM and CPU Physical Layout

Learn about DIMM and processor layout in the Oracle Database Appliance Version 1.

 **Note:**

Information in this appendix does NOT apply to Oracle Database Appliance X7 series, Oracle Database Appliance X6 series, or Oracle Database Appliance X3-2/X4-2/X5-2. Refer to the preceding chapters in this document for information on servicing those systems.

Each processor in Oracle Database Appliance Version 1 has six DIMM slots numbered D0 through D5. D0 is the closest to the processor and D5 is the farthest.

Each slot should contain a 1333 MHz or 1600 MHz DDR3, 8GB dual rank DIMM. No other configurations are supported.

The server node supports a maximum memory speed of 1333 MHz, even if it is configured with 1600 MHz DIMMs.

If the system contains a mixture of 1333 MHz and 1600 MHz DIMMs, then P0 and P1 should be configured the same, so that both sides are symmetrical. For example, if you install only two 1600 MHz DIMMs, they should go into P0, D0 and P1, D0.

The following figure shows the physical layout of the DIMMs and CPUs. When viewing the server node from the front, CPU0 (P0) is on the right.

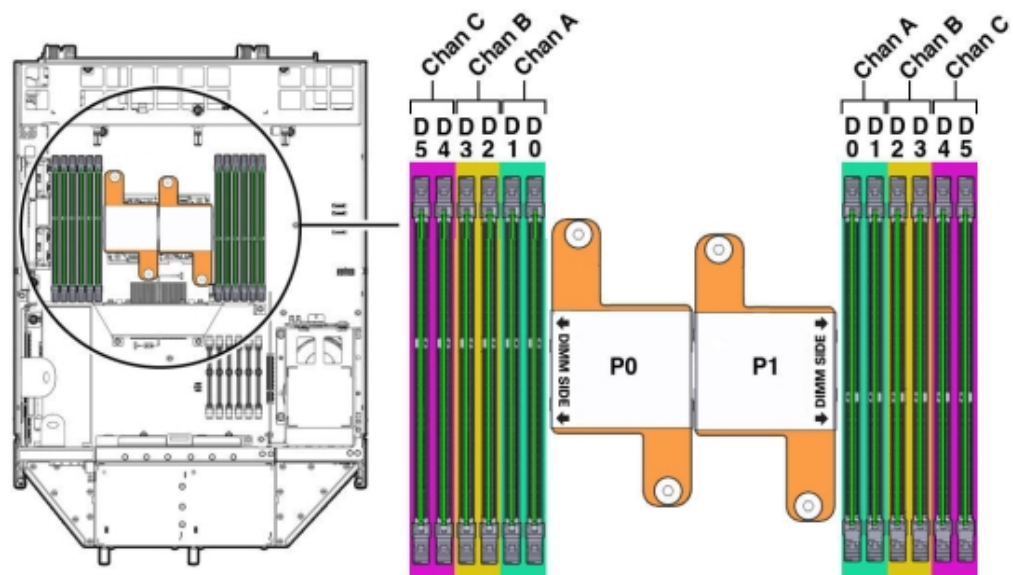

Each processor socket supports three independent memory channels labeled channel A, B, and C, where channel A is closest to the processor socket. Each channel supports two DIMM slots, is controlled by an independent memory controller, and operates independent of the other channels.

## A.3.2.2 Remove Faulty DIMMs

How to remove a DIMM from an Oracle Database Appliance Version 1.

 **Note:**

Information in this appendix does NOT apply to Oracle Database Appliance X7 series, Oracle Database Appliance X6 series, or Oracle Database Appliance X3-2/X4-2/X5-2. Refer to the preceding chapters in this document for information on servicing those systems.

1. Prepare the server node for service.
  - a. Attach an antistatic wrist strap.  
See [Performing Electrostatic Discharge and Antistatic Prevention Measures](#) (page A-8).
  - b. Remove the server node from the system.  
Power is removed from the server node when you remove it from the system. See [Removing Server Nodes From the System Chassis](#) (page A-9).
  - c. Remove the server node top cover.  
See [Removing the Server Node Top Cover](#) (page A-11).
2. Identify the faulty DIMM(s).
  - a. To identify the location of a faulty DIMMs, press the Fault Remind button on the motherboard as shown in the following figure.

 **Note:**

When the Fault Remind button is pressed, the Fault Remind Power Good LED lights green to indicate that there is sufficient voltage present in the fault remind circuit to light the fault LEDs. If this LED fails to light when you press the Fault Remind button, the capacitor powering the fault remind circuit has lost its charge. This can happen if the Fault Remind button is pressed for a long time with fault LEDs lit or if the server node has been out of the chassis for more than 15 minutes.

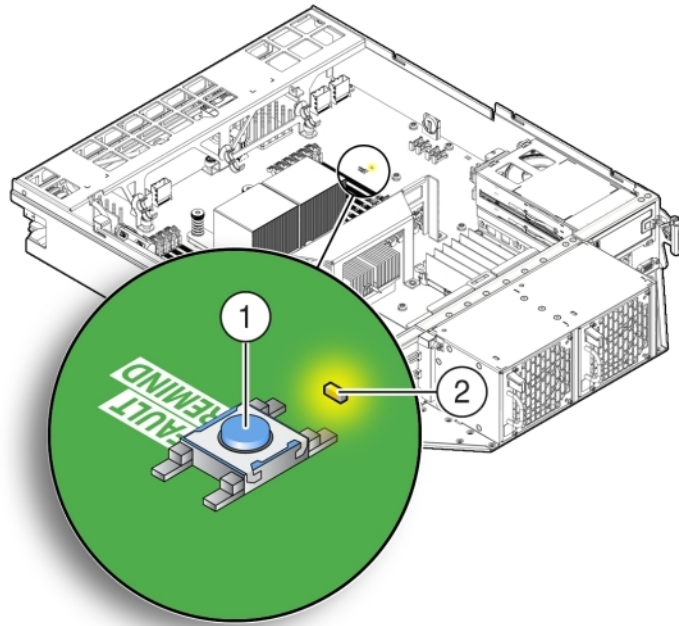

**Callout Description**

1	Fault Remind Button
2	Fault Remind Power Good LED (green)

b. Note the location of faulty DIMMs.

The amber DIMM fault LEDs light if the adjacent DIMM is faulty as shown in the following figure.

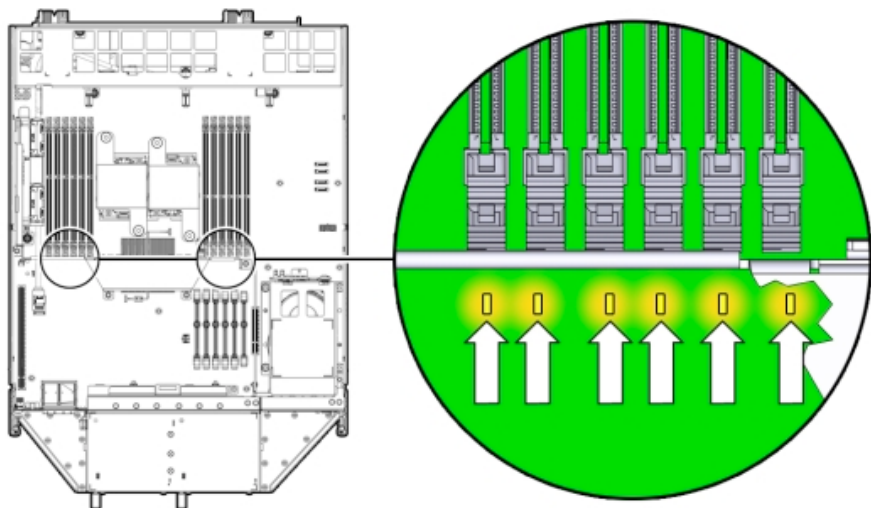

- If the DIMM fault LED is off, the DIMM is operating properly.

- If the DIMM fault Required LED is on (amber), the DIMM is faulty and should be replaced.
3. To remove the faulty DIMM(s), do the following:
    - a. Rotate both DIMM slot ejectors outward as far as they go.  
 The ejectors push the DIMM partially up.
    - b. Carefully lift the DIMM straight up to remove it from the socket as shown in the following figure.

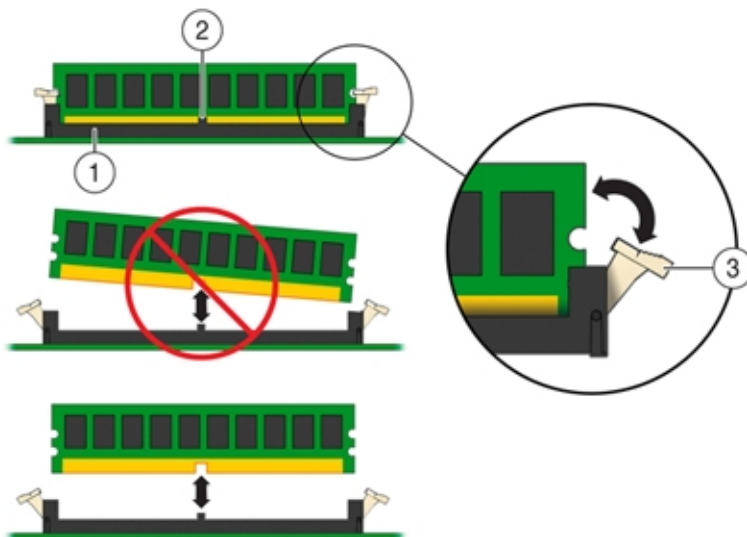

Callout	Description
---------	-------------

1	DIMM connector slot
2	DIMM connector key
3	DIMM ejector lever

4. Replace each faulty DIMM with either another DIMM of the same rank size.  
 For DIMM replacement instructions, see [Install DIMMs](#) (page A-35).

**▲ Caution:**

Do not operate the system with an empty DIMM slot. If you remove a DIMM, you must replace it before starting the server.



### A.3.2.3 Install DIMMs

How to install a DIMM in an Oracle Database Appliance Version 1.

 **Note:**

Information in this appendix does NOT apply to Oracle Database Appliance X7 series, Oracle Database Appliance X6 series, or Oracle Database Appliance X3-2/X4-2/X5-2. Refer to the preceding chapters in this document for information on servicing those systems.

1. Unpack the replacement DIMMs and place them on an antistatic mat.
2. Ensure that the replacement DIMMs match the system requirements.

The system supports only 1333 MHz or 1600 MHz DDR3, 8GB, dual rank DIMMs obtained from Oracle.

For the best performance, if you combine 1333 MHz and 1600 MHz DIMMs in a single system, they should be configured so that P0 and P1 have the same mixture, in the same DIMM slots. For example, in a 1333 MHz system, if you replace P0, D0 with a 1600 MHz DIMM, you should also replace P1, D0 with a 1600 MHz DIMM.

The server node supports a maximum memory speed of 1333 MHz, even if 1600 MHz DIMMs are installed.

3. Ensure that the ejector tabs are in the open position.
4. Align the replacement DIMM with the connector.

Align the notch in the DIMM with the key in the connector. The notch ensures that the DIMM is oriented correctly as shown in the following figure.

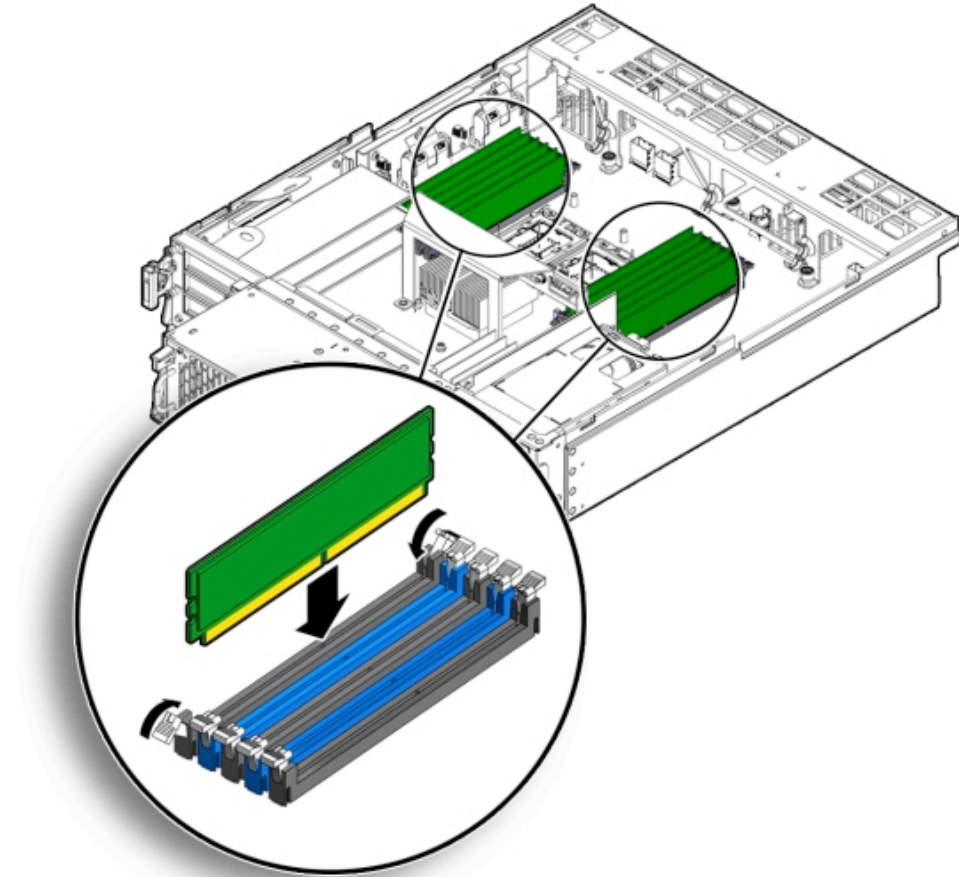

5. Push the DIMM into the connector until the ejector tabs lock the DIMM in place.  
If the DIMM does not easily seat into the connector, verify that the notch in the DIMM is aligned with the key in the connector as shown above. If the notch is not aligned, damage to the DIMM might occur.
6. Repeat Step 3 through Step 5 until all replacement DIMMs are installed.
7. Return the server node to operation.
  - a. Install the server node top cover.  
See [Installing the Server Node Top Cover](#) (page A-95).
  - b. Install the server node into the system.  
See [Installing a Server Node Into the System Chassis](#) (page A-96).
  - c. Power on the server node.  
See [Powering On Oracle Database Appliance Version 1](#) (page A-98).
8. Clear the DIMM faults.
  - a. Log in to the server node Oracle ILOM CLI as `root`.
  - b. To view server node faults, type the following command:  

```
-> show /SP/faultmgmt
```

Oracle ILOM lists all known faults. For example:

```
SP/faultmgmt
Targets:
0 (/SYS/MB/P0/D2)
Properties:
Commands:
cd
show
```

- c. To clear the DIMM fault, type the following command:

```
-> set /SYS/MB/Px/Dn clear_fault_action=true
```

For example, to clear a fault on the DIMM in location D2 on CPU0:

```
-> set /SYS/MB/P0/D2 clear_fault_action=true
Are you sure you want to clear /SYS/MB/P0 (y/n)? y
Set 'clear_fault_action' to 'true'
```

### A.3.2.4 Error Correction and Parity Protection

Learn about DIMM ECC and parity errors in the Oracle Database Appliance Version 1.

 **Note:**

Information in this appendix does NOT apply to Oracle Database Appliance X7 series, Oracle Database Appliance X6 series, or Oracle Database Appliance X3-2/X4-2/X5-2. Refer to the preceding chapters in this document for information on servicing those systems.

The Oracle Database Appliance Version 1 server node's processor provides parity protection on its internal cache memories, and error-correcting code (ECC) protection of the data. The server node detects and posts the following errors to the Oracle ILOM event log:

- Correctable and uncorrectable memory ECC errors
- Uncorrectable CPU internal errors

Advanced ECC corrects up to 4 bits in error on nibble boundaries, as long as they are all in the same DRAM. If a DRAM fails, the DIMM continues to function.

To clear a fault once the faulty DIMM has been replaced, type the following in the Oracle ILOM CLI:

```
-> set clear_fault_action=true
```

For more information on clearing DIMM faults, see the [Oracle Integrated Lights Out Manager \(Oracle ILOM\) 3.0 Documentation Collection](#).

### A.3.3 Servicing PCIe Risers (CRU)

Perform tasks for servicing PCIe risers in the Oracle Database Appliance Version 1.

 **Note:**

Information in this appendix does NOT apply to Oracle Database Appliance X7 series, Oracle Database Appliance X6 series, or Oracle Database Appliance X3-2/X4-2/X5-2. Refer to the preceding chapters in this document for information on servicing those systems.

PCIe cards in Oracle Database Appliance Version 1 are installed on a vertical riser. You must remove the riser to remove and replace a PCIe card. Also, you must remove the PCIe riser when replacing the motherboard.

 **Caution:**

These procedures require that you handle components that are sensitive to static discharge. This sensitivity can cause the component to fail. To avoid damage, ensure that you follow antistatic practices as described in [Performing Electrostatic Discharge and Antistatic Prevention Measures](#) (page A-8).

- [Remove PCIe Riser From Server Nodes](#) (page A-38)  
How to remove a PCIe riser from an Oracle Database Appliance Version 1 server node.
- [Install PCIe Riser in Server Nodes](#) (page A-40)  
How to install a PCIe riser in an Oracle Database Appliance Version 1 server node.

### A.3.3.1 Remove PCIe Riser From Server Nodes

How to remove a PCIe riser from an Oracle Database Appliance Version 1 server node.

 **Note:**

Information in this appendix does NOT apply to Oracle Database Appliance X7 series, Oracle Database Appliance X6 series, or Oracle Database Appliance X3-2/X4-2/X5-2. Refer to the preceding chapters in this document for information on servicing those systems.

1. Prepare the server node for service.
  - a. Attach an antistatic wrist strap.  
See [Performing Electrostatic Discharge and Antistatic Prevention Measures](#) (page A-8).
  - b. Remove the server node from the system.  
Power is removed from the server node when you remove it from the system. See [Removing Server Nodes From the System Chassis](#) (page A-9).

- c. Remove the server node top cover.

See [Removing the Server Node Top Cover](#) (page A-11).

- 2. If you are servicing a PCIe card, locate its position on the riser.
- 3. Disconnect any data cables connected to the cards on the PCIe riser being removed.

To disconnect a cable from a PCIe card, press the latch, push in toward the connector, and then pull out to remove the cable.

Note the location of all cables for reinstallation later.

- 4. Ensure that the latch adjacent to the location where PCIe riser is installed is in the open (down) position [1] as shown in the following figure.

If the latch is in the closed position, it prevents you from removing the PCIe riser.

- 5. Loosen the three green captive Phillips screws that secure the PCIe riser to the server node [1] as shown in the following figure.

Access these screws from the rear of the server node.

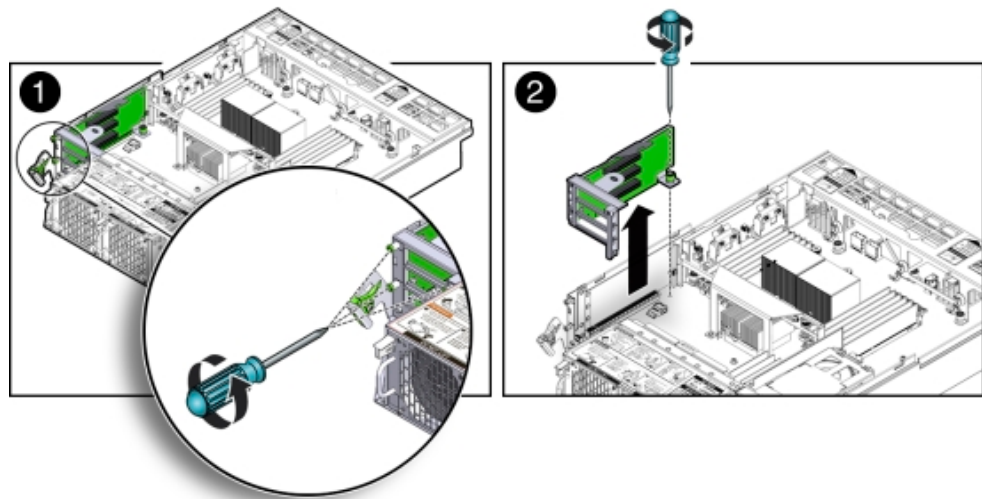

- 6. Loosen the green captive Phillips screw that secures the PCIe riser to the motherboard [2].
- 7. To lift the PCIe riser out of the server node, grasp the front-most side plastic tab with one hand and the rear of the riser with the other hand, and lift it straight up and out of the server node [2].
- 8. Place the PCIe riser and any cards attached to it on an antistatic mat.

## A.3.3.2 Install PCIe Riser in Server Nodes

How to install a PCIe riser in an Oracle Database Appliance Version 1 server node.

 **Note:**

Information in this appendix does NOT apply to Oracle Database Appliance X7 series, Oracle Database Appliance X6 series, or Oracle Database Appliance X3-2/X4-2/X5-2. Refer to the preceding chapters in this document for information on servicing those systems.

1. Before installing the PCIe riser, ensure that the latch adjacent to the location where PCIe riser is to be installed is in the open (down) position [2].
2. Install the PCIe riser.
  - a. Ensure that any PCIe cards installed in the PCIe riser are properly seated, and that the card's locking bracket is flush with the recess in the riser and is engaging the locking tab.

For instructions for installing a PCIe card into a PCIe riser, see [Install PCIe Card in PCIe Riser](#) (page A-44).

- b. Lower the PCIe riser, and any cards attached to it, into the server node and push the riser down until it seats into the connector on the motherboard [1] as shown in the following figure.
- c. Tighten the green captive Phillips screw that secures the riser to the motherboard [1] as shown in the following figure.

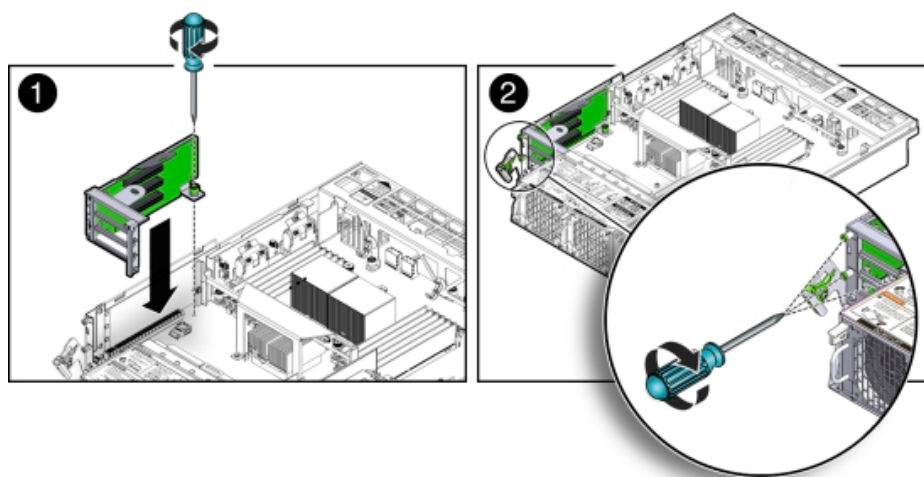

- d. Tighten the three green captive Phillips screws that secure the PCIe riser to the chassis [2] as shown in the previous figure.  
Access these screws from the rear of the server node.
3. Return the server node to operation.

- a. Install the server node top cover.  
 See [Installing the Server Node Top Cover](#) (page A-95).
  - b. Install the server node into the system.  
 See [Installing a Server Node Into the System Chassis](#) (page A-96).
  - c. Reconnect any data cables to the PCIe card connectors on the system rear panel.
  - d. Power on the server node.  
 See [Powering On Oracle Database Appliance Version 1](#) (page A-98).
4. Clear PCIe riser faults.
- a. Log in to the Oracle ILOM CLI as `root`.
  - b. Type:
 

```
-> show /SP/faultmgmt
```

Oracle ILOM lists all known faults. For example:

```
SP/faultmgmt
Targets:
0 (/SYS/MB/RISER)
Properties:
Commands:
cd
show
```
  - c. To clear PCIe riser faults, use the `set` command. For example:
 

```
-> set /SYS/MB/RISER clear_fault_action=true
Are you sure you want to clear /SYS/MB/RISER (y/n)? y
Set 'clear_fault_action' to 'true'
```

## A.3.4 Servicing PCIe Cards (CRU)

Perform tasks for servicing PCIe cards in the Oracle Database Appliance Version 1.

### Note:

Information in this appendix does NOT apply to Oracle Database Appliance X7 series, Oracle Database Appliance X6 series, or Oracle Database Appliance X3-2/X4-2/X5-2. Refer to the preceding chapters in this document for information on servicing those systems.

PCIe cards in Oracle Database Appliance Version 1 are installed on a vertical riser. You must remove the riser to remove and replace a PCIe card. See [Servicing PCIe Risers \(CRU\)](#) (page A-37).

 **Caution:**

These procedures require that you handle components that are sensitive to static discharge. This sensitivity can cause the component to fail. To avoid damage, ensure that you follow antistatic practices as described in [Performing Electrostatic Discharge and Antistatic Prevention Measures](#) (page A-8).

- [PCIe Card Configuration](#) (page A-42)  
Learn about PCIe cards in the Oracle Database Appliance Version 1.
- [Remove PCIe Card From PCIe Riser](#) (page A-43)  
How to remove a PCIe card from an Oracle Database Appliance Version 1 server node.
- [Install PCIe Card in PCIe Riser](#) (page A-44)  
How to install a PCIe card in an Oracle Database Appliance Version 1 server node.
- [Remove Primary HBA PCIe Card From Motherboard](#) (page A-46)  
How to remove the primary HBA card from an Oracle Database Appliance Version 1 server node.
- [Install Primary HBA PCIe Card in Motherboard](#) (page A-47)  
How to install the primary HBA card in an Oracle Database Appliance Version 1 server node.

### A.3.4.1 PCIe Card Configuration

Learn about PCIe cards in the Oracle Database Appliance Version 1.

 **Note:**

Information in this appendix does NOT apply to Oracle Database Appliance X7 series, Oracle Database Appliance X6 series, or Oracle Database Appliance X3-2/X4-2/X5-2. Refer to the preceding chapters in this document for information on servicing those systems.

The Oracle Database Appliance Version 1 PCIe expansion system includes one standalone low-profile slot on the motherboard and a PCIe riser with three slots. These are provisioned as follows:

- Motherboard slot: A low-profile, dual-port SAS-2 HBA used internally
- PCIe slot 2: Dual-port SAS-2 HBA used internally
- PCIe slot 1: Quad-port 1-Gb Ethernet NIC
- PCIe slot 0: Dual-port 10-Gb Ethernet NIC



 **Caution:**

If you replace a PCIe card, ensure the replacement is identical to the card you are replacing.

## A.3.4.2 Remove PCIe Card From PCIe Riser

How to remove a PCIe card from an Oracle Database Appliance Version 1 server node.

 **Note:**

Information in this appendix does NOT apply to Oracle Database Appliance X7 series, Oracle Database Appliance X6 series, or Oracle Database Appliance X3-2/X4-2/X5-2. Refer to the preceding chapters in this document for information on servicing those systems.

1. Prepare the server node for service.
  - a. Attach an antistatic wrist strap.  
See [Performing Electrostatic Discharge and Antistatic Prevention Measures](#) (page A-8).
  - b. Remove the server node from the system.  
Power is removed from the server node when you remove it from the system. See [Removing Server Nodes From the System Chassis](#) (page A-9).
  - c. Remove the server node top cover.  
See [Removing the Server Node Top Cover](#) (page A-11).
2. Locate the PCIe card in the PCIe riser that you want to remove.  
See the "Oracle Database Appliance Version 1 Back Panel" section of the *Oracle Database Owner's Guide* for the location of the PCIe slots.
3. If necessary, make a note of where the PCIe cards are installed.
4. Disconnect all data cables from the PCIe card.  
To disconnect a cable from the PCIe card, press the latch, push in toward the connector, and then pull out to remove the cable.  
Note the location of all cables for reinstallation later.
5. Remove the PCIe riser.  
See [Remove PCIe Riser From Server Nodes](#) (page A-38).
6. Remove the PCIe card from the riser.
  - a. Carefully disconnect the PCIe card from the riser connector and remove it from the riser board connector as shown in the following figure.

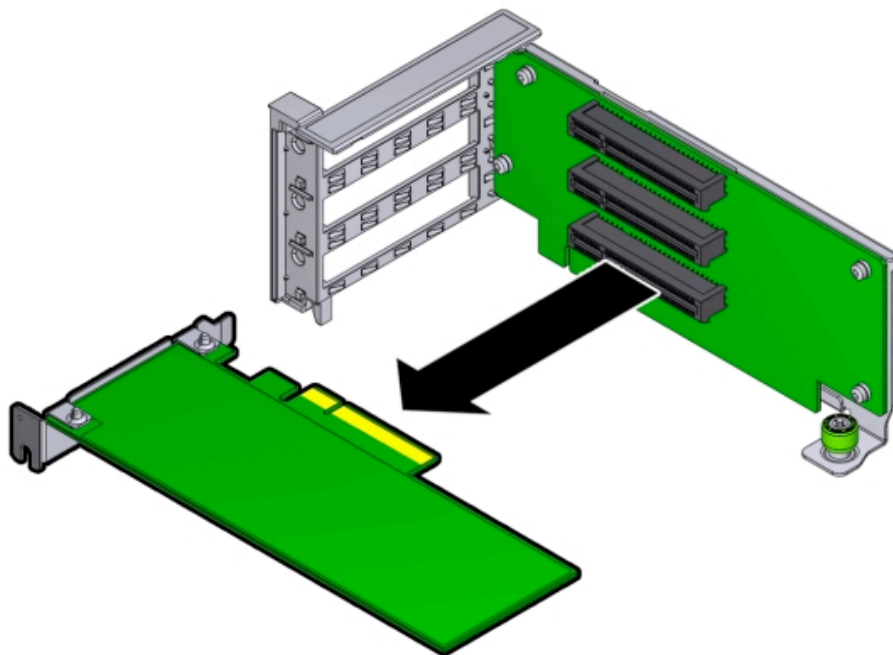

- b. Place the PCIe card on an antistatic mat.

### A.3.4.3 Install PCIe Card in PCIe Riser

How to install a PCIe card in an Oracle Database Appliance Version 1 server node.

 **Note:**

Information in this appendix does NOT apply to Oracle Database Appliance X7 series, Oracle Database Appliance X6 series, or Oracle Database Appliance X3-2/X4-2/X5-2. Refer to the preceding chapters in this document for information on servicing those systems.

1. Unpack the replacement PCIe card and place it on an antistatic mat.
2. Locate the proper PCIe slot for the card you are replacing.
3. Remove the PCIe riser.  
See [Remove PCIe Riser From Server Nodes](#) (page A-38).
4. Insert the PCIe card into the correct slot on the riser.
  - a. Press down on the PCIe card until its bracket [3] comes in contact with the recessed area [1] on the PCIe riser as shown in the following figure.
  - b. Ensure the card bracket engages the PCIe riser locking tab [2] as shown in the following figure.

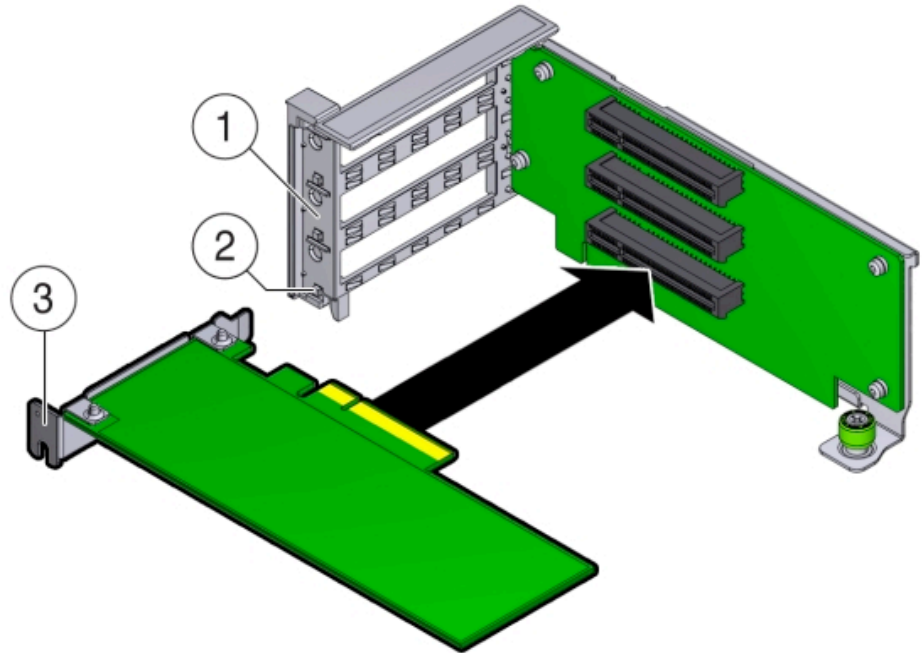

Callout	Description
---------	-------------

1	Recessed area on the PCIe riser
2	PCIe riser locking tab
3	PCIe card bracket

5. Install the PCIe riser.  
 See [Install PCIe Riser in Server Nodes](#) (page A-40).
6. Reconnect any cables to the PCIe card that you unplugged during the removal procedure.
7. Return the server node to operation.
  - a. Install the server node top cover.  
 See [Installing the Server Node Top Cover](#) (page A-95).
  - b. Install the server node into the system.  
 See [Installing a Server Node Into the System Chassis](#) (page A-96).
  - c. Reconnect any data cables to the PCIe card connectors on the system rear panel.
  - d. Power on the server node.  
 See [Powering On Oracle Database Appliance Version 1](#) (page A-98).
8. Clear the PCIe card fault.
  - a. Log in to the server node as `>root>` using the Oracle ILOM CLI.
  - b. To view server node faults, type the following command to list all known faults on the system:  

```
-> show /SP/faultmgmt
```

Oracle ILOM lists all known faults, for example:

```
SP/faultmgmt
Targets:
0 (/SYS/MB/RISER/PCIE2)
Properties:
Commands:
cd
show
```

- c. To clear PCIe riser faults, use the `set` command. For example:

```
-> set /SYS/MB/RISER clear_fault_action=true
Are you sure you want to clear /SYS/MB/RISER (y/n)? y
Set 'clear_fault_action' to 'true'
```

- d. To clear a PCIe card fault, use the `set` command. For example, to clear a fault on PCIe 2:

```
-> set /SYS/MB/RISER/PCIE2 clear_fault_action=true
Are you sure you want to clear /SYS/MB/RISER/PCIE2 (y/n)? y
Set 'clear_fault_action' to 'true'
```

### A.3.4.4 Remove Primary HBA PCIe Card From Motherboard

How to remove the primary HBA card from an Oracle Database Appliance Version 1 server node.



#### Note:

Information in this appendix does NOT apply to Oracle Database Appliance X7 series, Oracle Database Appliance X6 series, or Oracle Database Appliance X3-2/X4-2/X5-2. Refer to the preceding chapters in this document for information on servicing those systems.

1. Prepare the server node for service.
  - a. Attach an antistatic wrist strap.  
 See [Performing Electrostatic Discharge and Antistatic Prevention Measures](#) (page A-8).
  - b. Remove the server node from the system.  
 Power is removed from the server node when you remove it from the system. See [Removing Server Nodes From the System Chassis](#) (page A-9).
  - c. Remove the server node top cover.  
 See [Removing the Server Node Top Cover](#) (page A-11).
2. Remove the primary PCIe card.
  - a. Locate the Primary HBA PCIe card next to the rear-mounted disk drives.
  - b. Disconnect the data cables from the PCIe card by pressing each cable's release latch and removing the cable [1] as shown in the following figure.

 **Note:**

There are two data cables that connect the PCIe card to the server node disk drive backplane. Note their location for reinstallation later.

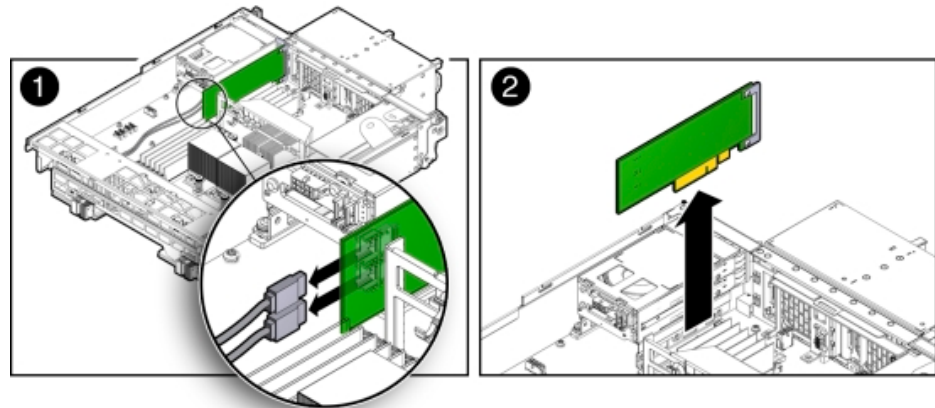

- c. Grasp the PCIe card and lift it up and out of the server node [2] as shown in the previous figure.
- d. Place the PCIe card on an antistatic mat.

### A.3.4.5 Install Primary HBA PCIe Card in Motherboard

How to install the primary HBA card in an Oracle Database Appliance Version 1 server node.

 **Note:**

Information in this appendix does NOT apply to Oracle Database Appliance X7 series, Oracle Database Appliance X6 series, or Oracle Database Appliance X3-2/X4-2/X5-2. Refer to the preceding chapters in this document for information on servicing those systems.

1. Unpack the replacement PCIe card and place it on an antistatic mat.

 **Note:**

To install a replacement HBA PCIe card into the primary HBA PCIe slot on the motherboard, a special metal bracket mounted to the PCIe card is required. The standard low-profile or full-height metal bracket standard on PCIe cards must be replaced with this unique metal bracket (available on the original primary HBA) before installation.

2. Install the internal PCIe card.

- a. Locate the internal PCIe card connector next to the rear-mounted disk drives.
- b. As you install the PCIe card, align the notch on the PCIe card with the key on the server node chassis wall and press down on the PCIe card to seat it into the connector [1] as shown in the following figure.

**▲ Caution:**

If the notch and key are not aligned, damage to the PCIe card might occur.

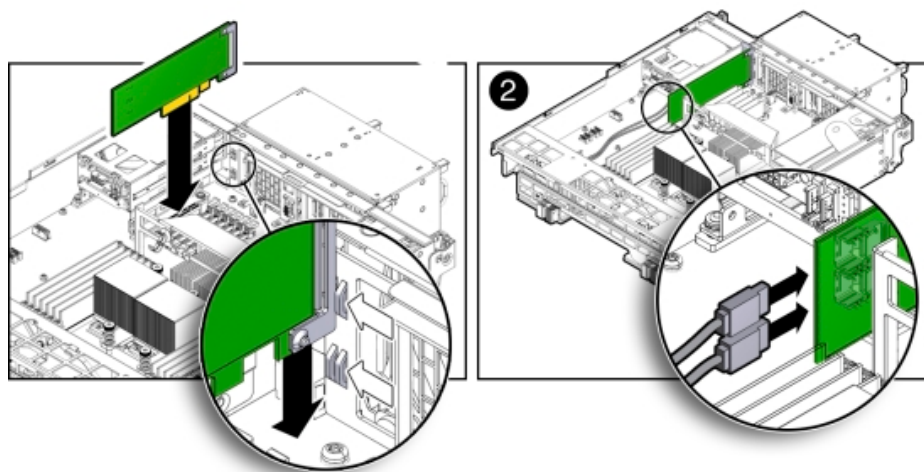

- c. Reconnect the cables to the primary HBA card connectors that you disconnected during the removal procedure [2] as shown in the previous figure.
3. Return the server node to operation.
    - a. Install the server node top cover.  
See [Installing the Server Node Top Cover](#) (page A-95).
    - b. Install the server node into the system.  
See [Installing a Server Node Into the System Chassis](#) (page A-96).
    - c. Power on the server node.  
See [Powering On Oracle Database Appliance Version 1](#) (page A-98).
  4. Clear the primary HBA card fault.
    - a. Log in to the server node as `root` using the Oracle ILOM CLI.
    - b. To view server node faults, type the following command to list all known faults on the server node:

```
-> show /SP/faultmgmt
```

Oracle ILOM lists all known faults, for example:

```
SP/faultmgmt  
Targets:  
0 (/SYS/MB/HBA)
```

```
Properties:  
Commands:  
cd  
show
```

- c. To clear the internal PCIe card fault, use the `set` command. For example:

```
-> set /SYS/MB/HBA clear_fault_action=true  
Are you sure you want to clear /SYS/MB/HBA (y/n)? y  
Set 'clear_fault_action' to 'true'
```

## A.3.5 Servicing the Server Node Battery (CRU)

Learn about servicing a server node system battery in the Oracle Database Appliance Version 1.

### Note:

Information in this appendix does NOT apply to Oracle Database Appliance X7 series, Oracle Database Appliance X6 series, or Oracle Database Appliance X3-2/X4-2/X5-2. Refer to the preceding chapters in this document for information on servicing those systems.

The Oracle Database Appliance Version 1 battery maintains the date and time for the Oracle ILOM service processor when the server node is removed from the system and, therefore, is powered off. If the server node fails to maintain the proper time when powered off, replace the battery.

### Caution:

These procedures require that you handle components that are sensitive to static discharge. This sensitivity can cause the component to fail. To avoid damage, ensure that you follow antistatic practices.

- [Remove Battery](#) (page A-50)  
How to remove the system battery in an Oracle Database Appliance Version 1 server node.
- [Install Battery](#) (page A-51)  
How to install the system battery in an Oracle Database Appliance Version 1 server node.

## A.3.5.1 Remove Battery

How to remove the system battery in an Oracle Database Appliance Version 1 server node.

 **Note:**

Information in this appendix does NOT apply to Oracle Database Appliance X7 series, Oracle Database Appliance X6 series, or Oracle Database Appliance X3-2/X4-2/X5-2. Refer to the preceding chapters in this document for information on servicing those systems.

1. Prepare the server node for service.
  - a. Attach an antistatic wrist strap.  
See [Performing Electrostatic Discharge and Antistatic Prevention Measures](#) (page A-8).
  - b. Remove the server node from the system.  
Power is removed from the server node when you remove it from the system. See [Removing Server Nodes From the System Chassis](#) (page A-9).
  - c. Remove the server node top cover.  
See [Removing the Server Node Top Cover](#) (page A-11).
2. Remove the battery.
  - a. Place your finger between the battery and the server node side wall and push the battery away from the side wall.
  - b. Twist the battery (either clockwise or counter-clockwise) and lift it out as shown in the following figure.

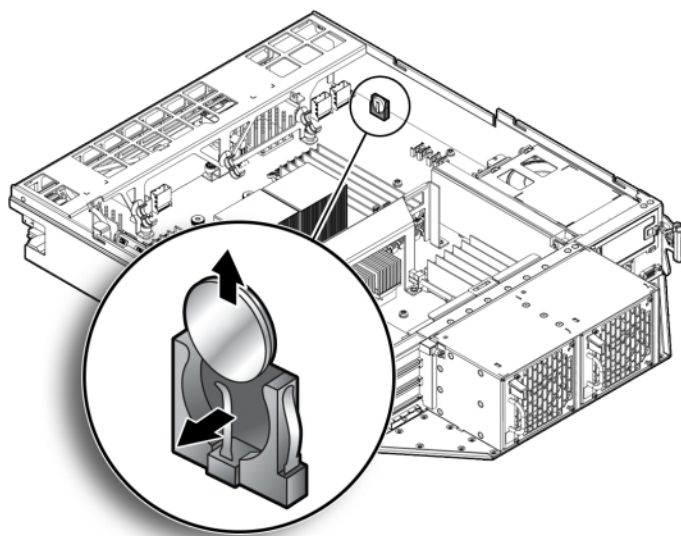



## A.3.5.2 Install Battery

How to install the system battery in an Oracle Database Appliance Version 1 server node.

 **Note:**

Information in this appendix does NOT apply to Oracle Database Appliance X7 series, Oracle Database Appliance X6 series, or Oracle Database Appliance X3-2/X4-2/X5-2. Refer to the preceding chapters in this document for information on servicing those systems.

1. Unpack the replacement battery.
2. Press the new battery into the battery holder with the positive side (+) facing the server node side wall.
3. If the service processor is configured to synchronize with a network time server using the Network Time Protocol (NTP), the Oracle ILOM clock is reset as soon as the server node is powered on and connected to the network. Otherwise, proceed to the next step.
4. If the service processor is not configured to use NTP, you must reset the Oracle ILOM clock using the Oracle ILOM CLI or the web interface.

For instructions, see the [Oracle Integrated Lights Out Manager \(Oracle ILOM\) 3.0 Documentation](#).

5. Return the server node to operation.
  - a. Install the server node top cover.  
See [Installing the Server Node Top Cover](#) (page A-95).
  - b. Install the server node into the system.  
See [Installing a Server Node Into the System Chassis](#) (page A-96).
  - c. Power on the server node.  
See [Powering On Oracle Database Appliance Version 1](#) (page A-98).

## A.4 Servicing FRUs

Perform tasks for servicing field-replaceable units (FRUs) for the Oracle Database Appliance Version 1 that require you to power off the system and/or server node.

 **Note:**

Information in this appendix does NOT apply to Oracle Database Appliance X7 series, Oracle Database Appliance X6 series, or Oracle Database Appliance X3-2/X4-2/X5-2. Refer to the preceding chapters in this document for information on servicing those systems.

 **Note:**

Only authorized Oracle Service personnel can service field-replaceable unit (FRU) components.

- [Removing and Installing the Air Duct \(FRU\)](#) (page A-52)  
Learn about removing and installing the air duct for an Oracle Database Appliance Version 1.
- [Servicing Processors \(CPUs\) \(FRU\)](#) (page A-55)  
Learn about servicing processors in an Oracle Database Appliance Version 1 server module.
- [Servicing the Boot Disk Backplane \(FRU\)](#) (page A-61)  
Learn about servicing the boot disk backplane in an Oracle Database Appliance Version 1 server module.
- [Servicing the Power Distribution Board \(FRU\)](#) (page A-63)  
Learn about servicing the power distribution board in an Oracle Database Appliance Version 1.
- [Servicing the Disk Midplane Module \(FRU\)](#) (page A-67)  
Learn about servicing the disk midplane module in an Oracle Database Appliance Version 1.
- [Servicing the Disk Midplane Module HDD Cable \(FRU\)](#) (page A-72)  
Learn about servicing the disk midplane module HDD cable in an Oracle Database Appliance Version 1.
- [Servicing the Front Indicator Panels \(FRU\)](#) (page A-74)  
Learn about servicing the front indicator panel of an Oracle Database Appliance Version 1.
- [Servicing Server Node Cables](#) (page A-78)  
Perform tasks for servicing the Oracle Database Appliance Version 1 server node cables.
- [Servicing the Motherboard Assembly \(FRU\)](#) (page A-90)  
Learn about servicing the motherboard in an Oracle Database Appliance Version 1 server node.

## A.4.1 Removing and Installing the Air Duct (FRU)

Learn about removing and installing the air duct for an Oracle Database Appliance Version 1.

 **Note:**

Information in this appendix does NOT apply to Oracle Database Appliance X7 series, Oracle Database Appliance X6 series, or Oracle Database Appliance X3-2/X4-2/X5-2. Refer to the preceding chapters in this document for information on servicing those systems.

The air duct for the Oracle Database Appliance Version 1 must be removed to service the CPUs.

The air duct is a FRU and can only be replaced by an Oracle-qualified service technician.

 **Caution:**

**Equipment overheating.** Ensure that the air duct is installed correctly before powering on the server.

- [Remove Air Duct](#) (page A-53)  
How to remove an air duct in an Oracle Database Appliance Version 1 server node.
- [Install Air Duct](#) (page A-54)  
How to install an air duct in an Oracle Database Appliance Version 1 server node.

### A.4.1.1 Remove Air Duct

How to remove an air duct in an Oracle Database Appliance Version 1 server node.

 **Note:**

Information in this appendix does NOT apply to Oracle Database Appliance X7 series, Oracle Database Appliance X6 series, or Oracle Database Appliance X3-2/X4-2/X5-2. Refer to the preceding chapters in this document for information on servicing those systems.

1. Prepare the server node for service.
  - a. Attach an antistatic wrist strap.  
See [Performing Electrostatic Discharge and Antistatic Prevention Measures](#) (page A-8).
  - b. Remove the server node from the system.  
Power is removed from the server node when you remove it from the system. See [Removing Server Nodes From the System Chassis](#) (page A-9).
  - c. Remove the server node top cover.  
See [Removing the Server Node Top Cover](#) (page A-11).
2. Remove the air duct.
  - a. From the rear of the server node, grasp the middle/rear of the air duct with your right hand and lift it up to a 45 degree angle [1] as shown in the following figure.  
  
The air duct swings up and away from the rear of the system.

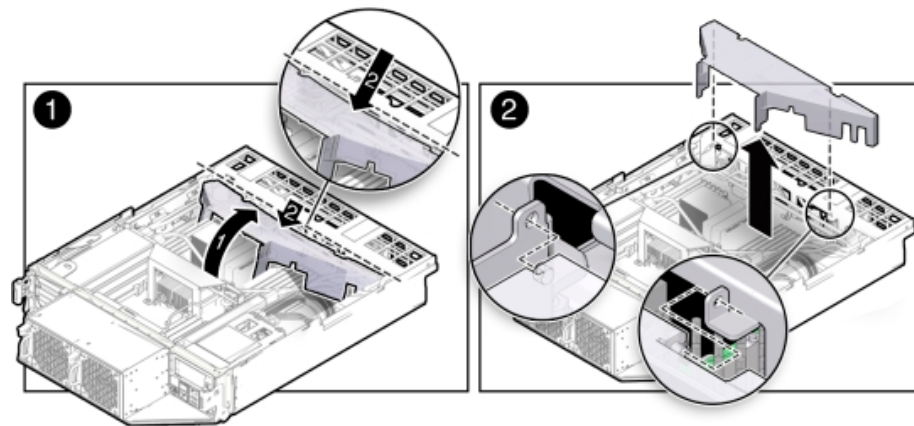

- b. Grasp the left end of the plastic air duct with your left hand to hold it at a 45 degree angle, and with your right hand press gently down on the middle of the air duct until it bends enough to disengage its hinges from their sockets and allow removal of the air duct [2] as shown in the previous figure.

## A.4.1.2 Install Air Duct

How to install an air duct in an Oracle Database Appliance Version 1 server node.

### Note:

Information in this appendix does NOT apply to Oracle Database Appliance X7 series, Oracle Database Appliance X6 series, or Oracle Database Appliance X3-2/X4-2/X5-2. Refer to the preceding chapters in this document for information on servicing those systems.

### Caution:

**Equipment overheating.** Ensure that the air duct is installed correctly before powering on the server.

1. Install the air duct into the chassis.
  - a. From the rear of the server node, insert the air duct's right hinge into the right-side socket [2], and place the left hinge on top of the left-side socket.
  - b. Grasp the left end of the air duct with your left hand to hold it at a 45 degree angle, and, with your right hand, press gently down on the middle of the air duct until it bends enough to insert the left hinge into the left-side socket [2].
  - c. Carefully lower the air duct to its closed position, with particular attention given to the SAS cables [1].

Ensure that the openings on each side of the air duct fit around the cables and not on top of them.

 **Caution:**

**Equipment overheating.** Verify that the air duct is fully closed.

2. Return the server node to operation.
  - a. Install the server node top cover.  
See [Installing the Server Node Top Cover](#) (page A-95).
  - b. Install the server node into the system.  
See [Installing a Server Node Into the System Chassis](#) (page A-96).
  - c. Power on the server node.  
See [Powering On Oracle Database Appliance Version 1](#) (page A-98).

## A.4.2 Servicing Processors (CPUs) (FRU)

Learn about servicing processors in an Oracle Database Appliance Version 1 server module.

 **Note:**

Information in this appendix does NOT apply to Oracle Database Appliance X7 series, Oracle Database Appliance X6 series, or Oracle Database Appliance X3-2/X4-2/X5-2. Refer to the preceding chapters in this document for information on servicing those systems.

The CPU is a FRU and can only be replaced by an Oracle-qualified service technician.

 **Caution:**

**Equipment damage.** These procedures require that you handle components that are sensitive to static discharge. This sensitivity can cause the component to fail. To avoid damage, ensure that you follow antistatic practices.

- [Remove Processor \(CPU\)](#) (page A-56)  
How to remove a processor from an Oracle Database Appliance Version 1 server node.
- [Install Processor \(CPU\)](#) (page A-59)  
How to install a processor in an Oracle Database Appliance Version 1 server node.

## A.4.2.1 Remove Processor (CPU)

How to remove a processor from an Oracle Database Appliance Version 1 server node.

### Note:

Information in this appendix does NOT apply to Oracle Database Appliance X7 series, Oracle Database Appliance X6 series, or Oracle Database Appliance X3-2/X4-2/X5-2. Refer to the preceding chapters in this document for information on servicing those systems.

### Caution:

**Equipment overheating.** If you remove a CPU/heatsink from the system, you should replace it or install a CPU filler before you return the server to operation; otherwise, the system might overheat due to improper airflow.

1. Prepare the server node for service.
  - a. Attach an antistatic wrist strap.  
See [Performing Electrostatic Discharge and Antistatic Prevention Measures](#) (page A-8).
  - b. Remove the server node from the system.  
Power is removed from the server node when you remove it from the system. See [Removing Server Nodes From the System Chassis](#) (page A-9).
  - c. Remove the server node top cover.  
See [Removing the Server Node Top Cover](#) (page A-11).
  - d. Remove the air duct.  
See [Remove Air Duct](#) (page A-53).
2. Remove the CPU.
  - a. Identify which CPU to remove.
  - b. To identify the location of the faulty CPU, press the Fault Remind button on the motherboard.

 **Note:**

When the Fault Remind button is pressed, the Fault Remind Power Good indicator (LED) lights green to indicate that there is sufficient voltage present in the fault remind circuit to light the fault indicators. If this indicator fails to light when you press the Fault Remind button, the capacitor powering the fault remind circuit has lost its charge. This can happen if the Fault Remind button is pressed for a long time with fault indicators lit or if the server node has been out of the chassis for more than 15 minutes.

- c. The fault LED for the faulty CPU lights.

The fault LED is located next to the CPU as shown in the following figure.

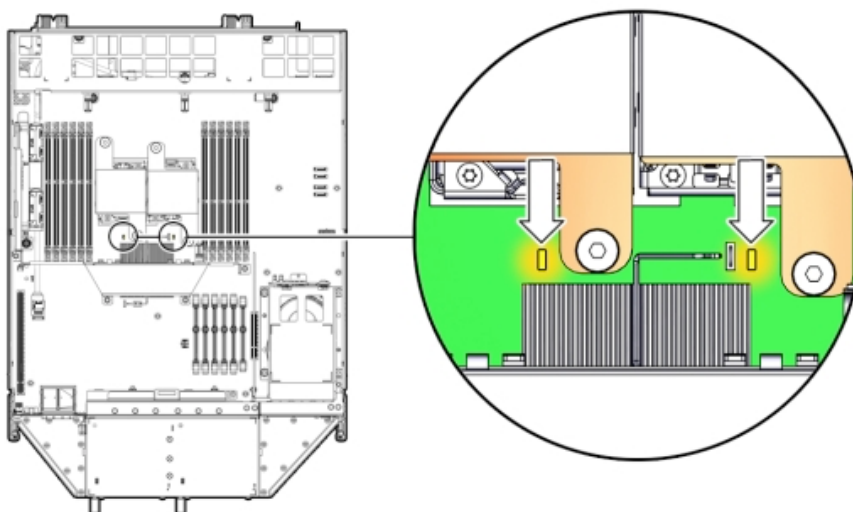

- If CPU fault LED is off: CPU is operating properly.
- If CPU fault LED is on (amber): CPU is faulty and should be replaced.

Viewing the server node from the front, CPU0 (P0) is on the right side of the server node.

- d. Using a Phillips screwdriver, turn one captive screw on the heatsink counterclockwise two full turns, then turn the other screw two full turns, and keep alternating between the two screws until they are removed [2] as shown in the following figure.

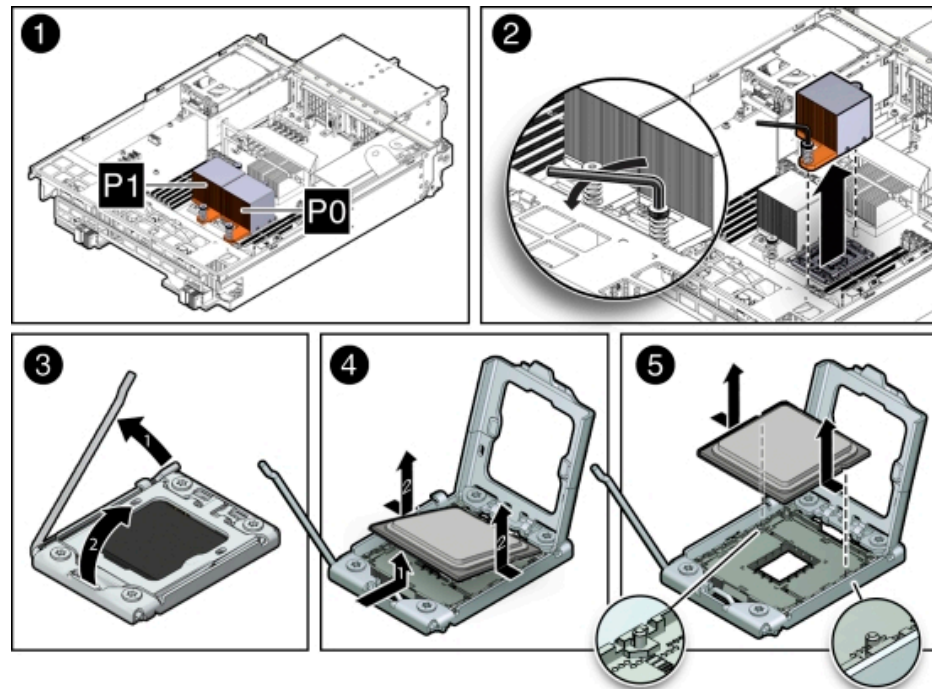

- e. Twist the heatsink slightly to break the grease seal, then lift it off and place it upside down on a flat surface to prevent the thermal grease from contaminating other components.
- f. Using the wipes supplied with the replacement CPU, carefully clean the thermal grease from both the bottom of the heatsink and the top of the CPU.

**▲ Caution:**

**Equipment damage.** When cleaning the top of the CPU, be careful not to get the thermal grease on your fingers, the CPU socket or other associated components as this could result in contamination.

- g. Disengage the CPU release lever by pushing down and moving it to the side away from the CPU, and then rotating the lever upward [3] as shown in the previous figure.
- h. Raise the pressure frame on the CPU to the open position [3].
- i. Use your index finger to carefully lift up the edge of the CPU or protective cap that is farthest from the socket alignment slots [4] as shown in the previous figure, then firmly grasp both sides of the CPU or protective cap with your thumb and index finger on your other hand [4], and carefully lift the CPU or protective cap up and out of the socket [5] as shown in the previous figure.



## A.4.2.2 Install Processor (CPU)

How to install a processor in an Oracle Database Appliance Version 1 server node.

 **Note:**

Information in this appendix does NOT apply to Oracle Database Appliance X7 series, Oracle Database Appliance X6 series, or Oracle Database Appliance X3-2/X4-2/X5-2. Refer to the preceding chapters in this document for information on servicing those systems.

1. Attach an antistatic wrist strap.  
See [Performing Electrostatic Discharge and Antistatic Prevention Measures](#) (page A-8).
2. Unpack the replacement CPU.  
The CPU replacement kit includes a new CPU, wipes, and a tube of thermal grease.
3. Install the CPU.
  - a. Grasp the sides of the CPU firmly with your thumb and index finger, tilt it at a 45 degree angle, orient it with the socket alignment tabs [2] as shown in the following figure.

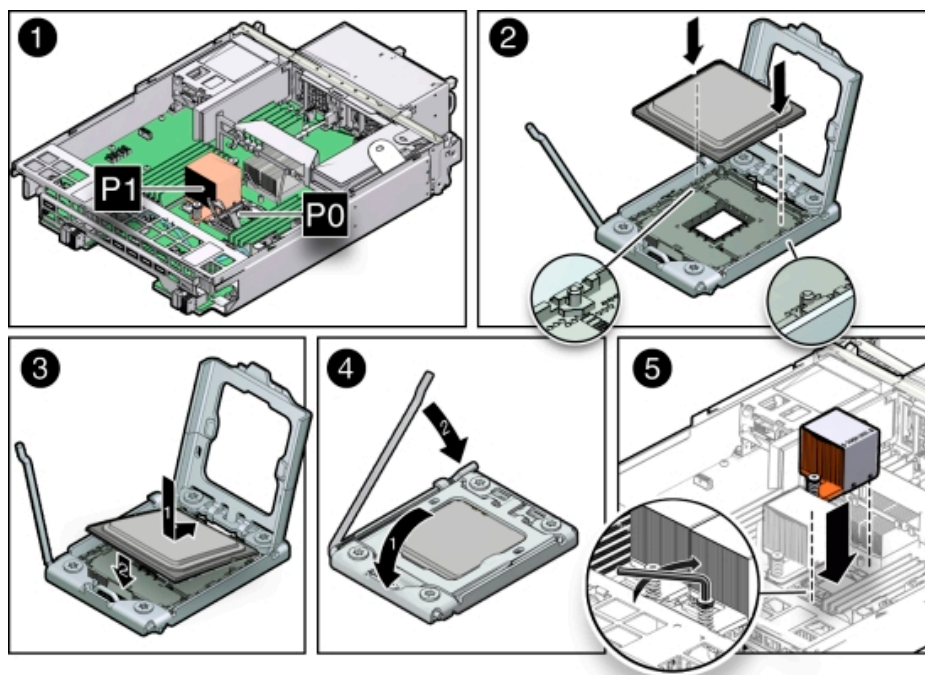

- b. Carefully lower the end of the CPU with the alignment tabs into the socket, support the raised end of the CPU with the index finger on your other hand, and lower the CPU into the socket [3] as shown in the previous figure.

- c. Lower the pressure frame to the closed position, ensuring that the pressure frame sits flat around the periphery of the CPU [4-1] as shown in the previous figure. Then engage the release lever by rotating it downward and slipping it under the catch [4-2].
- d. Ensure that there is no debris on the top of the CPU die.
- e. Use the syringe (supplied with the new or replacement CPU) to apply approximately 0.1 ml of thermal grease to the center of the top of the CPU. Do not distribute the grease.
- f. Orient the heatsink so that the DIMM SIDE label on the top of the heatsink is facing the memory modules (DIMMs) and the two captive Phillips screws align with the mounting studs.  
  
Each heatsink is labeled to indicate which side of the heatsink faces the memory modules (DIMMs) when the heatsink is properly oriented.
- g. Tighten the two Phillips screws alternately two full turns at a time until the screws are fully seated [5] as shown in the previous figure.

4. Return the server node to operation.

- a. Install the air duct.  
See [Install Air Duct](#) (page A-54).
- b. Install the server node top cover.  
See [Installing the Server Node Top Cover](#) (page A-95).
- c. Install the server node into the system.  
See [Installing a Server Node Into the System Chassis](#) (page A-96).
- d. Power on the server node.  
See [Powering On Oracle Database Appliance Version 1](#) (page A-98).

5. Clear the CPU faults.

- a. Log in to the server node as `root` using the Oracle ILOM CLI.
- b. To view server node faults, type the following command to list all known faults on the system:

```
-> show /SP/faultmgmt
```

Oracle ILOM lists all known faults, for example:

```
SP/faultmgmt
Targets:
0 (/SYS/MB/P0)
Properties:
Commands:
cd
show
```

- c. To clear the fault, type the following command:

```
-> set /SYS/MB/Pn clear_fault_action=true
```

For example, to clear a fault on P0:

```
-> set /SYS/MB/P0 clear_fault_action=true
Are you sure you want to clear /SYS/MB/P0 (y/n)? y
Set 'clear_fault_action' to 'true'
```

## A.4.3 Servicing the Boot Disk Backplane (FRU)

Learn about servicing the boot disk backplane in an Oracle Database Appliance Version 1 server module.

### Note:

Information in this appendix does NOT apply to Oracle Database Appliance X7 series, Oracle Database Appliance X6 series, or Oracle Database Appliance X3-2/X4-2/X5-2. Refer to the preceding chapters in this document for information on servicing those systems.

The Oracle Database Appliance Version 1 boot disk backplane (BDB) serves as an interface between the motherboard and the rear-mounted disk drives.

The boot disk backplane is a FRU and can only be replaced by an Oracle-qualified service technician.

### Caution:

**Equipment damage.** These procedures require that you handle components that are sensitive to static discharge. This sensitivity can cause the component to fail. To avoid damage, ensure that you follow antistatic practices.

- [Remove Boot Disk Backplane](#) (page A-61)  
How to remove the boot disk backplane from an Oracle Database Appliance Version 1 server node.
- [Install Boot Disk Backplane](#) (page A-62)  
How to install the boot disk backplane in an Oracle Database Appliance Version 1 server node.

### A.4.3.1 Remove Boot Disk Backplane

How to remove the boot disk backplane from an Oracle Database Appliance Version 1 server node.

### Note:

Information in this appendix does NOT apply to Oracle Database Appliance X7 series, Oracle Database Appliance X6 series, or Oracle Database Appliance X3-2/X4-2/X5-2. Refer to the preceding chapters in this document for information on servicing those systems.

1. Prepare the server node for service.

- a. Attach an antistatic wrist strap.  
See [Performing Electrostatic Discharge and Antistatic Prevention Measures](#) (page A-8).
  - b. Remove the server node from the system.  
Power is removed from the server node when you remove it from the system. See [Removing Server Nodes From the System Chassis](#) (page A-9).
  - c. Remove the server node top cover.  
See [Removing the Server Node Top Cover](#) (page A-11).
2. Unseat the boot disk drives.  
See [Remove a Boot Drive](#) (page A-20).
  3. Remove the boot disk backplane.
    - a. Disconnect the power and data cables [1] as shown in the following figure.

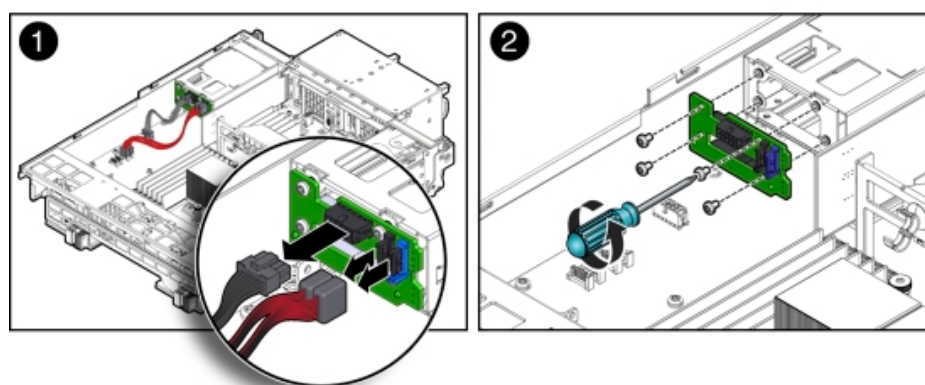

- b. Remove the four Phillips screws that secure the boot disk backplane to the rear-mounted disk drives assembly and remove the backplane [2] as shown in the previous figure.
4. Place the boot disk backplane on an antistatic mat.

### A.4.3.2 Install Boot Disk Backplane

How to install the boot disk backplane in an Oracle Database Appliance Version 1 server node.

#### Note:

Information in this appendix does NOT apply to Oracle Database Appliance X7 series, Oracle Database Appliance X6 series, or Oracle Database Appliance X3-2/X4-2/X5-2. Refer to the preceding chapters in this document for information on servicing those systems.

1. Install the boot disk backplane.

- a. Position the boot disk backplane on the rear-mounted disk drives assembly and install and tighten the four Phillips screws to secure the backplane [2] as shown in the previous figure.
  - b. Reconnect the power cable and the data cables [1] as shown in the previous figure.
2. Return the server node to operation.
    - a. Re-seat the boot disk drives.  
See [Install a Boot Drive](#) (page A-21).
    - b. Install the server node top cover.  
See [Installing the Server Node Top Cover](#) (page A-95).
    - c. Install the server node into the system.  
See [Installing a Server Node Into the System Chassis](#) (page A-96).
    - d. Power on the server node.  
See [Powering On Oracle Database Appliance Version 1](#) (page A-98).

## A.4.4 Servicing the Power Distribution Board (FRU)

Learn about servicing the power distribution board in an Oracle Database Appliance Version 1.

### Note:

Information in this appendix does NOT apply to Oracle Database Appliance X7 series, Oracle Database Appliance X6 series, or Oracle Database Appliance X3-2/X4-2/X5-2. Refer to the preceding chapters in this document for information on servicing those systems.

The Oracle Database Appliance Version 1 power distribution board (PDB) distributes power from the power supplies to all system components.

The power distribution board is a FRU and can only be replaced by an Oracle-qualified service technician.

### Caution:

**Equipment damage.** These procedures require that you handle components that are sensitive to static discharge. This sensitivity can cause the component to fail. To avoid damage, ensure that you follow antistatic practices.

 **Caution:**

**Equipment damage.** Remove all power from the system before removing or installing the power distribution board. Power down both server nodes (also called system controllers) and disconnect the power cords from the system before performing these procedures. For instructions, see [Shutting Down a Server Node and Powering Off the System](#) (page A-5).

- [Remove Power Distribution Board](#) (page A-64)  
How to remove the power distribution board from an Oracle Database Appliance Version 1.
- [Install Power Distribution Board](#) (page A-66)  
How to install the power distribution board in an Oracle Database Appliance Version 1.

### A.4.4.1 Remove Power Distribution Board

How to remove the power distribution board from an Oracle Database Appliance Version 1.

 **Note:**

Information in this appendix does NOT apply to Oracle Database Appliance X7 series, Oracle Database Appliance X6 series, or Oracle Database Appliance X3-2/X4-2/X5-2. Refer to the preceding chapters in this document for information on servicing those systems.

1. Prepare the system for service.
  - a. Power off the system.  
See [Shutting Down a Server Node and Powering Off the System](#) (page A-5).
  - b. Disconnect the power cords from the system.
  - c. If the system is installed in a rack, remove it.  
For information on racking the system chassis, see the *Oracle Database Appliance Owner's Guide*.
  - d. Remove both power supplies from the system.  
See [Remove a Power Supply](#) (page A-26).
  - e. Attach an antistatic wrist strap.  
See [Performing Electrostatic Discharge and Antistatic Prevention Measures](#) (page A-8).
2. Remove both server nodes from the system.  
See [Removing Server Nodes From the System Chassis](#) (page A-9).
3. Remove the middle section of the system top cover.  
See [Removing the Middle Section of the System Top Cover](#) (page A-12).

4. Remove the power distribution board.
  - a. Disconnect the ribbon cable connector on the power distribution board [1] as shown in the following figure.

The ribbon cable is located between the power distribution board and the chassis side wall. It connects the power distribution board to the disk midplane.

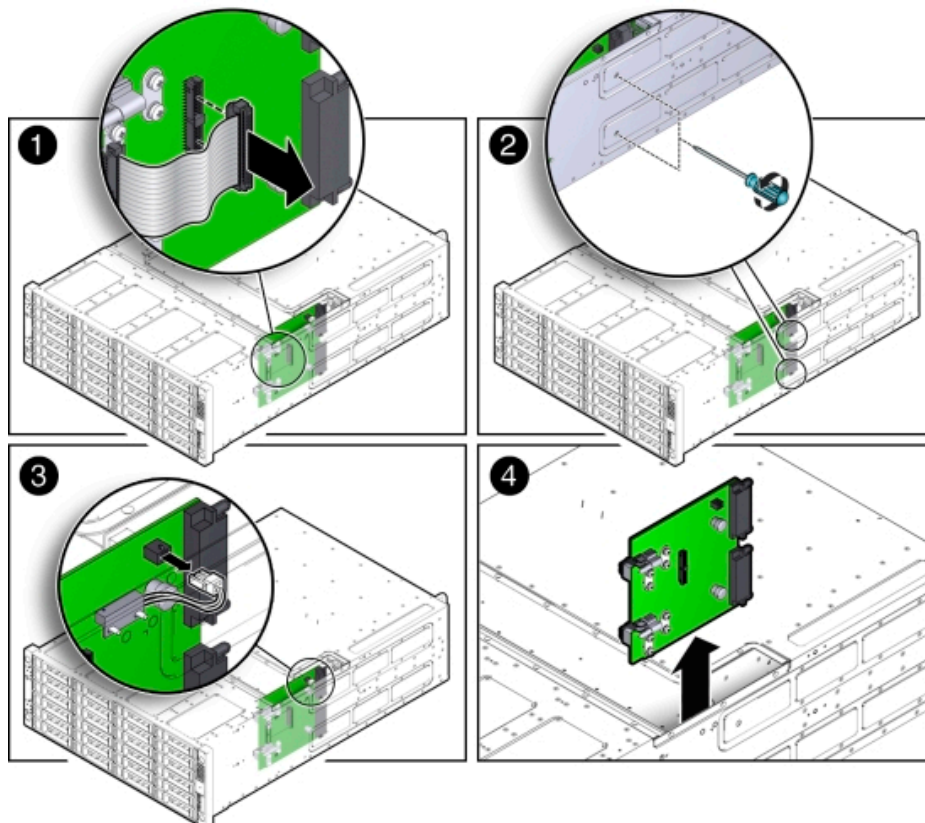

- b. Remove the two Phillips screws that secure the power distribution board to the chassis [2] as shown in the previous figure.

You access the screws through two holes in the side of the chassis.
    - c. Carefully remove the chassis interlock switch connector from the power distribution board [3] as shown in the previous figure.

To gain access to the chassis interlock switch connector, grasp the power distribution board with both hands, slide it to the rear of the system chassis to unplug it from the disk midplane module, and lift it up until you can grasp and remove the connector.
    - d. Lift the power distribution board out of the system chassis [4] as shown in the previous figure.
    - e. Place the power distribution board on the antistatic mat



## A.4.4.2 Install Power Distribution Board

How to install the power distribution board in an Oracle Database Appliance Version 1.

 **Note:**

Information in this appendix does NOT apply to Oracle Database Appliance X7 series, Oracle Database Appliance X6 series, or Oracle Database Appliance X3-2/X4-2/X5-2. Refer to the preceding chapters in this document for information on servicing those systems.

1. Install the power distribution board into the system chassis.
  - a. Lower the power distribution board partially into the system [1] as shown in the following figure.

**Figure A-1 Installing the Power Distribution Board**

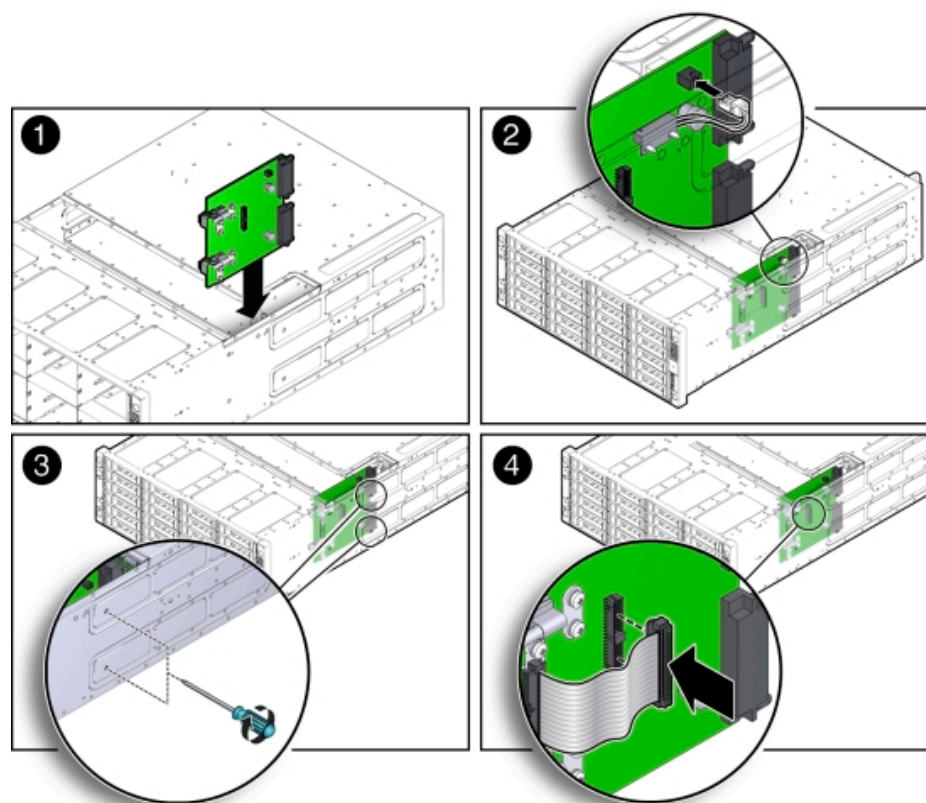

- b. Reconnect the chassis interlock switch cable [2] as shown in the previous figure.
    - c. Align the power distribution board with the two power connectors on the disk midplane module and slide the power distribution board forward until the connectors seat.



- d. To secure the power distribution board to the system, use the holes in the system side wall to access and tighten the two Phillips screws [3] as shown in the previous figure.
      - e. Reconnect the power distribution board ribbon cable [4] as shown in the previous figure.
2. Return the system to operation.
  - a. Install both server nodes into the system.

See [Installing a Server Node Into the System Chassis](#) (page A-96).
  - b. Install the middle section of the top cover.

Install and tighten the Phillips screws that secure the middle section of the top cover to the system chassis.
  - c. Install both power supplies into the system.

See [Install a Power Supply](#) (page A-27).
  - d. If the system was installed in a rack, reinstall it into the rack.

See the *Oracle Database Appliance Owner's Guide* for instructions.
  - e. Reconnect the power cords to the system and power on the system.

See [Powering On Oracle Database Appliance Version 1](#) (page A-98).

## A.4.5 Servicing the Disk Midplane Module (FRU)

Learn about servicing the disk midplane module in an Oracle Database Appliance Version 1.

### Note:

Information in this appendix does NOT apply to Oracle Database Appliance X7 series, Oracle Database Appliance X6 series, or Oracle Database Appliance X3-2/X4-2/X5-2. Refer to the preceding chapters in this document for information on servicing those systems.

The Oracle Database Appliance Version 1 disk midplane interconnects the front disk drives to the server nodes, the front indicator modules, and the power distribution board (PDB).

The disk midplane board is a FRU and can only be replaced by an Oracle-qualified service technician.

### Caution:

**Equipment damage.** These procedures require that you handle components that are sensitive to static discharge. This sensitivity can cause the component to fail. To avoid damage, ensure that you follow antistatic practices.

 **Caution:**

**Equipment damage.** Remove all power from the system before removing or installing the power distribution board. Power down both server nodes (also called system controllers) and disconnect the power cords from the system before performing these procedures. For instructions, see [Shutting Down a Server Node and Powering Off the System](#) (page A-5).

- [Remove Disk Midplane Module](#) (page A-68)  
How to remove the disk midplane module from an Oracle Database Appliance Version 1.
- [Install Disk Midplane Module](#) (page A-71)  
How to install the disk midplane module in an Oracle Database Appliance Version 1.

### A.4.5.1 Remove Disk Midplane Module

How to remove the disk midplane module from an Oracle Database Appliance Version 1.

 **Note:**

Information in this appendix does NOT apply to Oracle Database Appliance X7 series, Oracle Database Appliance X6 series, or Oracle Database Appliance X3-2/X4-2/X5-2. Refer to the preceding chapters in this document for information on servicing those systems.

1. Prepare the system for service.
  - a. Power off the system.  
See [Shutting Down a Server Node and Powering Off the System](#) (page A-5).
  - b. Disconnect the power cords from the system.
  - c. If the system is installed in a rack, remove it.  
See the *Oracle Database Appliance Owner's Guide* for information on racking the system chassis.
  - d. Remove both power supplies from the system.  
See [Remove a Power Supply](#) (page A-26).
  - e. Attach an antistatic wrist strap.  
See [Performing Electrostatic Discharge and Antistatic Prevention Measures](#) (page A-8).
2. Remove all of the front storage drives.  
See [Remove a Storage Drive](#) (page A-17).
3. Remove both server nodes from the system.  
See [Removing Server Nodes From the System Chassis](#) (page A-9).

4. Remove the middle section of the system top cover.  
See [Removing the Middle Section of the System Top Cover](#) (page A-12).
5. Loosen the two captive Phillips screws that secure the side-wall cover to the chassis and remove the cover.

The side-wall cover is positioned under the middle section of the system top cover. Before you can remove the side-wall cover, you must remove the middle section of the system top cover as shown in the following figure.

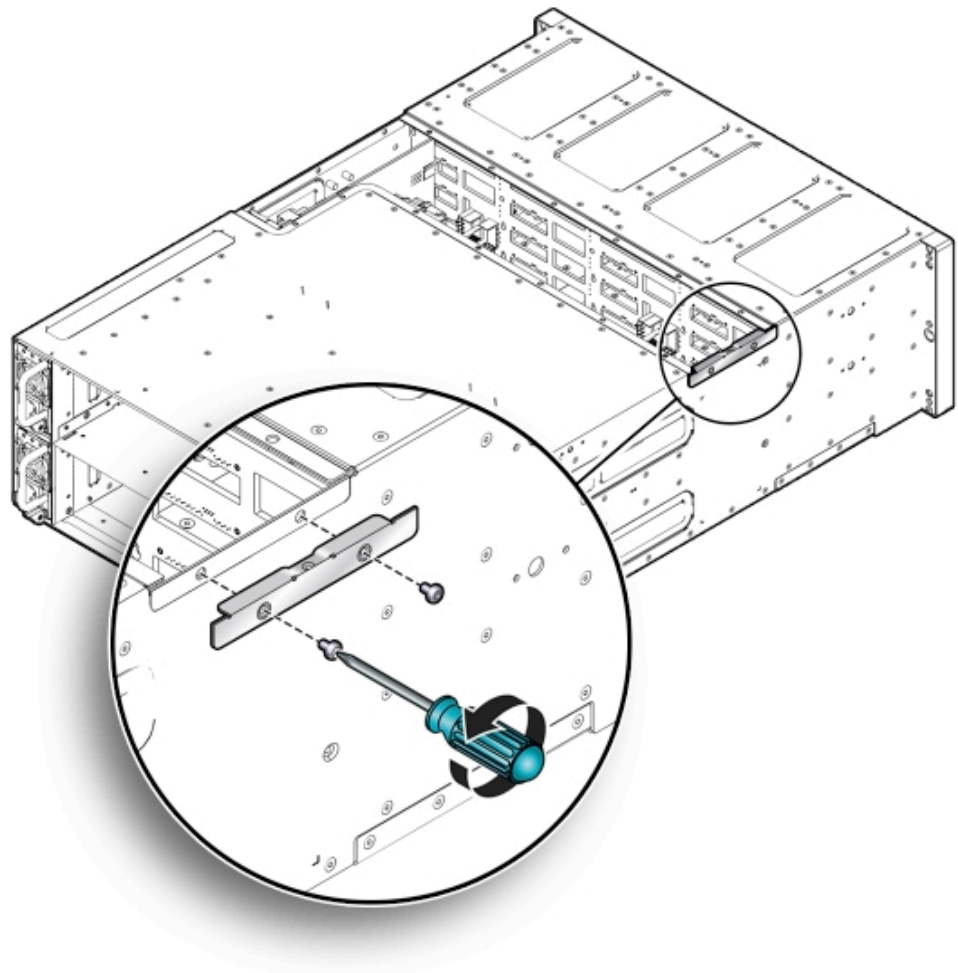

6. Remove the power distribution board.  
See [Remove Power Distribution Board](#) (page A-64).
7. Remove the disk midplane module.
  - a. Before disconnecting the two front indicator module (FIM) cable connectors from the disk midplane module, label them: the lower connector on the disk midplane is for SN0 and the upper connector is for SN1.
  - b. Disconnect the two FIM cable connectors from the disk midplane module [1] as shown in the following figure.

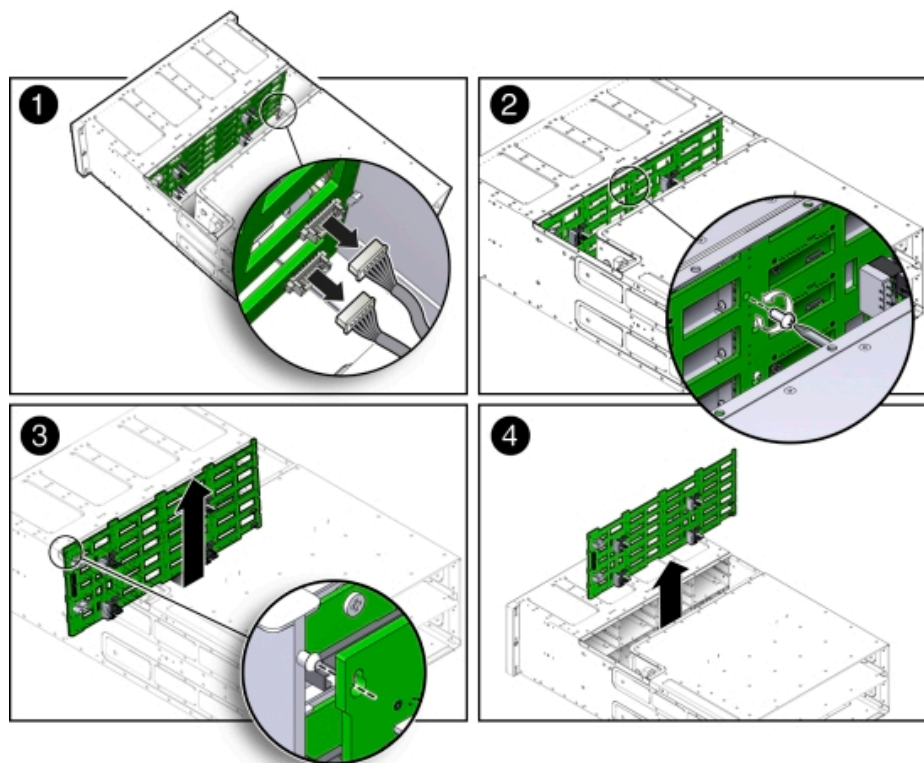

- c. Remove the Phillips screw that secures the disk midplane module to the disk drive cage [2] as shown in the previous figure.
- d. To remove the disk midplane module from the system chassis, lift the board up about 0.25 inches (6.35 mm) to clear the standoffs that hold it in place [3] as shown in the previous figure.

To remove the board, you might need to move the bottom of the board away from the disk drive cage to disengage the standoff located at the top left corner of the board. Then, you should be able to lift the board up and out of the system.

There are four columns of standoffs, four in the left-most column and three in each of the remaining columns.

- e. Lift the disk midplane module up and out of the system [4] as shown in the previous figure.
- f. Place the board on an antistatic mat.

## A.4.5.2 Install Disk Midplane Module

How to install the disk midplane module in an Oracle Database Appliance Version 1.

 **Note:**

Information in this appendix does NOT apply to Oracle Database Appliance X7 series, Oracle Database Appliance X6 series, or Oracle Database Appliance X3-2/X4-2/X5-2. Refer to the preceding chapters in this document for information on servicing those systems.

1. Install the disk midplane module.
  - a. Move the front indicator module (FIM) cable connectors toward the rear of the system so that the disk midplane module is not installed over them.
  - b. Lower the disk midplane module in the system chassis [1] as shown in the following figure.

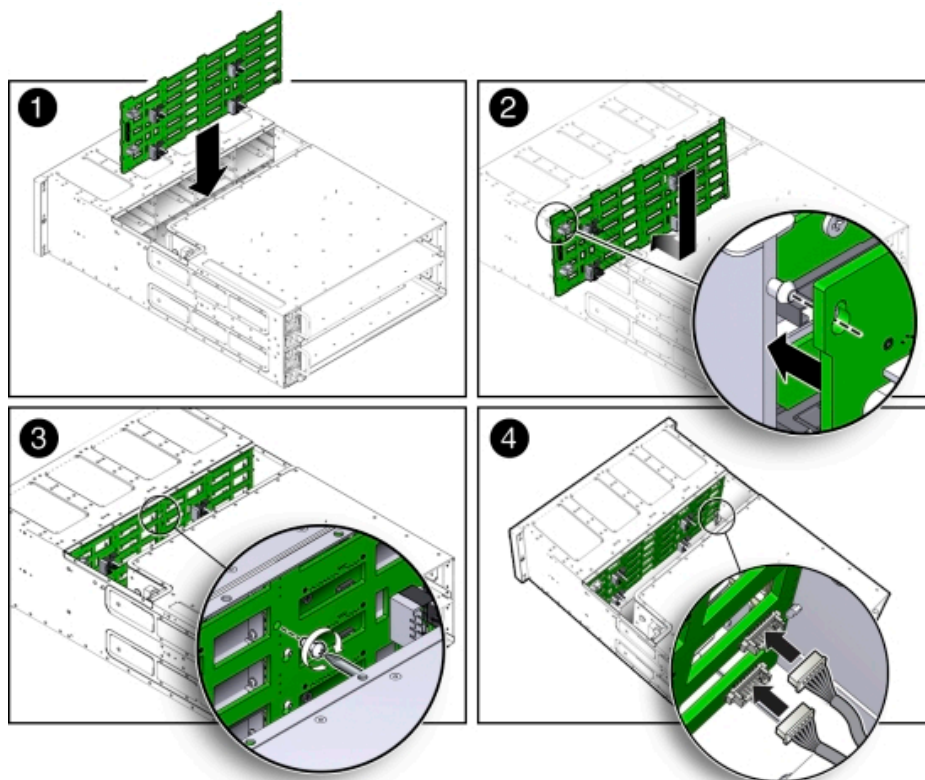

- c. Position the disk midplane module against the disk drive cage, tilting the top slightly forward so that it fits over the top-most standoff on the left side and then position board so that it fits over the remaining 12 standoffs [2] as shown in the previous figure.
    - d. To secure the disk midplane module to the disk drive cage, install the Phillips screw [3] as shown in the previous figure.

- e. Reconnect the two FIM cable connectors to the receptacles on the disk midplane module [4] as shown in the previous figure.  
Ensure that the FIM connectors are properly connected. The lower connector on the disk midplane is for SN0 and the upper connector is for SN1.
2. Install the power distribution board into the system.  
See [Install Power Distribution Board](#) (page A-66).
3. Position the side-wall cover into the chassis and tighten the two captive Phillips screws to secure the side-wall cover to the chassis.
4. Install the middle section of the system's top cover.  
Install and tighten the Phillips screws that secure the middle section of the top cover to the system chassis.
5. Reinstall all of the front storage drives.  
See [Install Storage Drive](#) (page A-18).
6. Install both server nodes into the system.  
See [Installing a Server Node Into the System Chassis](#) (page A-96).
7. Return the system to operation.
  - a. Install both power supplies into the system.  
See [Install a Power Supply](#) (page A-27).
  - b. If the system was installed in a rack, reinstall it into the rack.  
See the *Oracle Database Appliance Owner's Guide* for instructions.
  - c. Reconnect the power cords to the system and power on the system.  
See [Powering On Oracle Database Appliance Version 1](#) (page A-98).

## A.4.6 Servicing the Disk Midplane Module HDD Cable (FRU)

Learn about servicing the disk midplane module HDD cable in an Oracle Database Appliance Version 1.



### Note:

Information in this appendix does NOT apply to Oracle Database Appliance X7 series, Oracle Database Appliance X6 series, or Oracle Database Appliance X3-2/X4-2/X5-2. Refer to the preceding chapters in this document for information on servicing those systems.

The Oracle Database Appliance Version 1 HDD cable connects the power distribution board to the disk midplane module.

The disk midplane module HDD cable is a FRU and can only be replaced by an Oracle-qualified service technician.

 **Caution:**

**Equipment damage.** Remove all power from the system before removing or installing the power distribution board. Power down both server nodes (also called system controllers) and disconnect the power cords from the system before performing these procedures. For instructions, see [Shutting Down a Server Node and Powering Off the System](#) (page A-5).

- [Remove Disk Midplane Module HDD Cable](#) (page A-73)  
How to remove the disk midplane module HDD cable from an Oracle Database Appliance Version 1.
- [Install Disk Midplane Module HDD Cable](#) (page A-74)  
How to install the disk midplane module HDD cable in an Oracle Database Appliance Version 1.

### A.4.6.1 Remove Disk Midplane Module HDD Cable

How to remove the disk midplane module HDD cable from an Oracle Database Appliance Version 1.

 **Note:**

Information in this appendix does NOT apply to Oracle Database Appliance X7 series, Oracle Database Appliance X6 series, or Oracle Database Appliance X3-2/X4-2/X5-2. Refer to the preceding chapters in this document for information on servicing those systems.

1. Prepare the system for service.
  - a. Power off the system.  
See [Shutting Down a Server Node and Powering Off the System](#) (page A-5).
  - b. Disconnect the power cords from the system.
  - c. If the system is installed in a rack, remove it.  
See the *Oracle Database Appliance Owner's Guide* for instructions.
  - d. Attach an antistatic wrist strap.  
See [Performing Electrostatic Discharge and Antistatic Prevention Measures](#) (page A-8).
2. Remove the middle section of the system top cover.  
See [Removing the Middle Section of the System Top Cover](#) (page A-12).
3. Disconnect the HDD ribbon cable connector located on the power distribution board [1] as shown in the following figure.



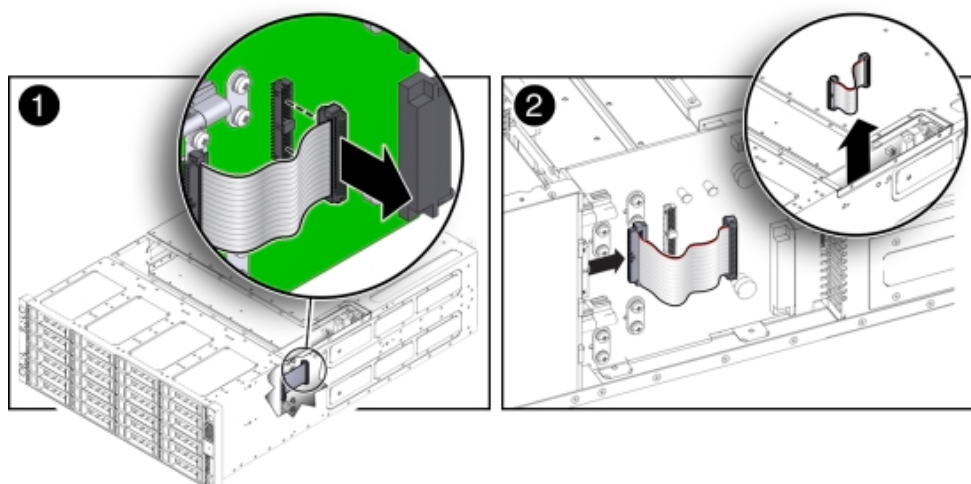

4. Disconnect the HDD ribbon cable connector located on the disk midplane module [2] as shown in the previous figure.

## A.4.6.2 Install Disk Midplane Module HDD Cable

How to install the disk midplane module HDD cable in an Oracle Database Appliance Version 1.

### Note:

Information in this appendix does NOT apply to Oracle Database Appliance X7 series, Oracle Database Appliance X6 series, or Oracle Database Appliance X3-2/X4-2/X5-2. Refer to the preceding chapters in this document for information on servicing those systems.

1. Reconnect the HDD ribbon cable connector located on the disk midplane module [2]).
2. Reconnect the HDD ribbon cable connector located on the power distribution board [1].
3. Return the system to operation.
  - a. Install the middle section of the system top cover.  
Install and tighten the Phillips screws that secure the middle section of the top cover to the system chassis.
  - b. If the system was installed in a rack, reinstall it into the rack.  
See the *Oracle Database Appliance Owner's Guide* for instructions.
  - c. Reconnect the power cords to the system and power on the system.  
See [Powering On Oracle Database Appliance Version 1](#) (page A-98).

## A.4.7 Servicing the Front Indicator Panels (FRU)

Learn about servicing the front indicator panel of an Oracle Database Appliance Version 1.



 **Note:**

Information in this appendix does NOT apply to Oracle Database Appliance X7 series, Oracle Database Appliance X6 series, or Oracle Database Appliance X3-2/X4-2/X5-2. Refer to the preceding chapters in this document for information on servicing those systems.

The Oracle Database Appliance Version 1 front indicator panels contain the LEDs and indicators on the front of the system. Each server node has its own front indicator panel, which sits behind the ears on the system chassis.

The front indicator panels are FRUs and can only be replaced by an Oracle-qualified service technician.

 **Caution:**

**Equipment damage.** Remove all power from the system before removing or installing the power distribution board. Power down both server nodes (also called system controllers) and disconnect the power cords from the system before performing these procedures. For instructions, see [Shutting Down a Server Node and Powering Off the System](#) (page A-5).

- [Remove Front Indicator Panel](#) (page A-75)  
How to remove a front indicator panel from an Oracle Database Appliance Version 1.
- [Install Front Indicator Panel](#) (page A-77)  
How to install a front indicator panel in an Oracle Database Appliance Version 1.

## A.4.7.1 Remove Front Indicator Panel

How to remove a front indicator panel from an Oracle Database Appliance Version 1.

 **Note:**

Information in this appendix does NOT apply to Oracle Database Appliance X7 series, Oracle Database Appliance X6 series, or Oracle Database Appliance X3-2/X4-2/X5-2. Refer to the preceding chapters in this document for information on servicing those systems.

1. Prepare the system for service.
  - a. Power off the system (both server nodes).  
See [Shutting Down a Server Node and Powering Off the System](#) (page A-5).
  - b. Disconnect the power cords from the system.
  - c. If the system is installed in a rack, remove it.

See the *Oracle Database Appliance Owner's Guide* for information on racking the system chassis.

- d. Attach an antistatic wrist strap.

See [Performing Electrostatic Discharge and Antistatic Prevention Measures](#) (page A-8).

2. Remove the adjacent disk drives [1] as shown in the following figure.

Be sure to mark them so that you can return them to the correct drive bays later.

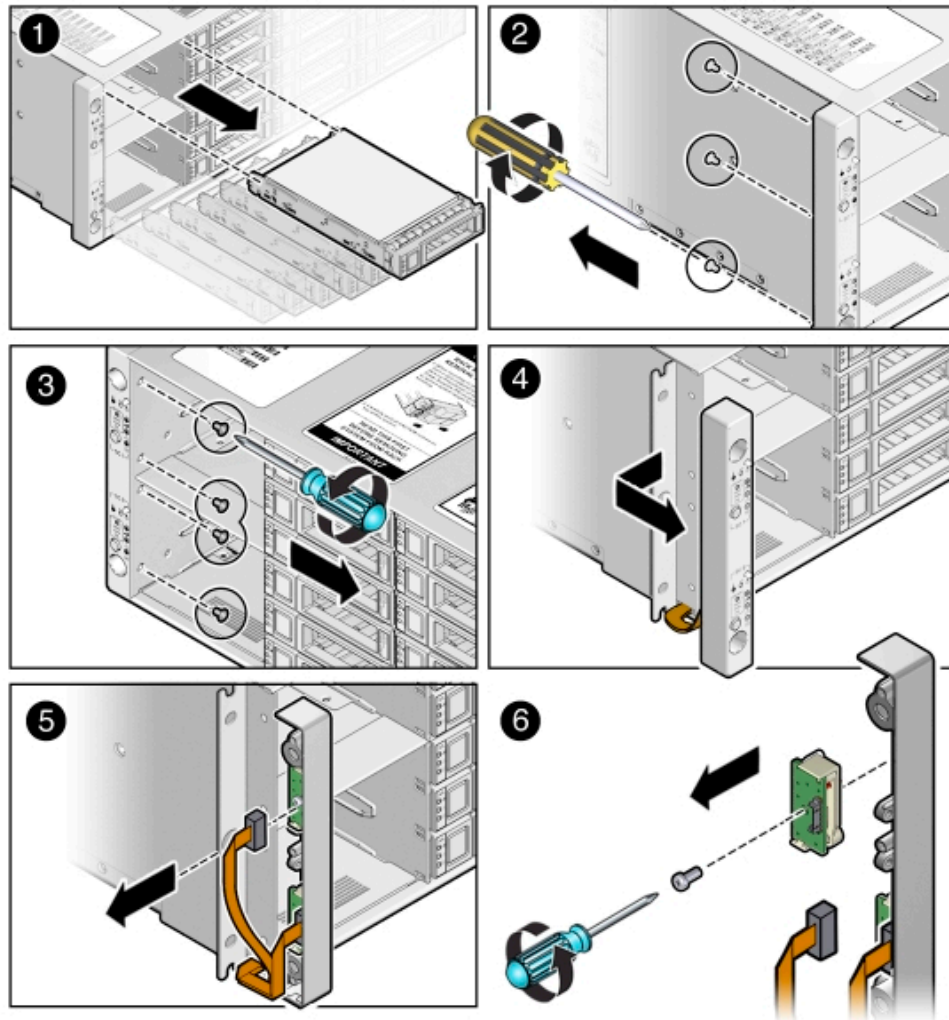

3. Unscrew the three Phillips screws from the back of the ear bezel [2] as shown in the previous figure.
4. Remove four more Phillips screws from the inside of the drive bays [3] as shown in the previous figure.
5. Remove the ear bezel [4] as shown in the previous figure.  
The ear bezel and indicator panels remain connected to the ribbon cables.
6. Disconnect the ribbon cables from the indicator panel you wish to change [5] as shown in the previous figure.

- Remove the screw that holds the indicator panel to the ear bezel [6] as shown in the previous figure.

Make sure you remove the correct indicator panel. There are two indicator panels on the ear bezel.

## A.4.7.2 Install Front Indicator Panel

How to install a front indicator panel in an Oracle Database Appliance Version 1.

### Note:

Information in this appendix does NOT apply to Oracle Database Appliance X7 series, Oracle Database Appliance X6 series, or Oracle Database Appliance X3-2/X4-2/X5-2. Refer to the preceding chapters in this document for information on servicing those systems.

- Use the Phillips screw to attach the new indicator panel to the ear bezel [1] as shown in the following figure.

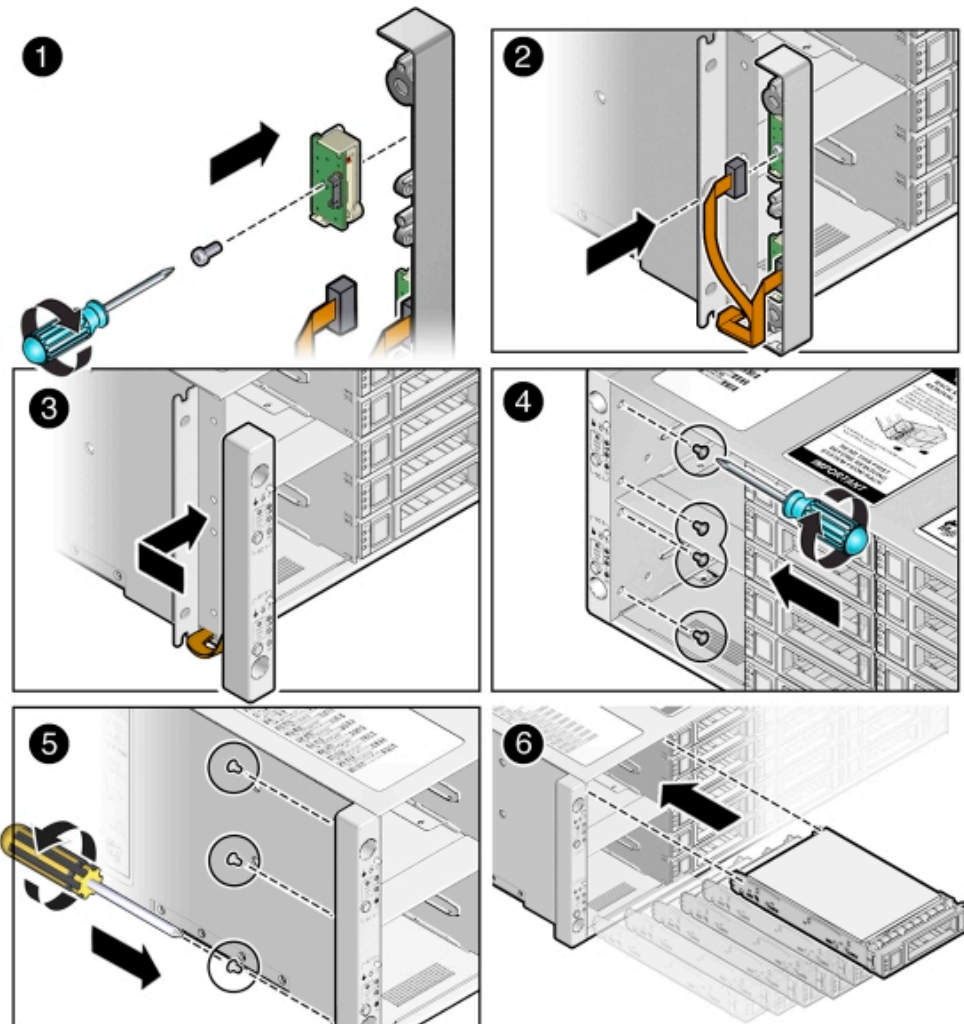

2. Connect the ribbon cable to the indicator panel [2] as shown in the previous figure.
3. Place the ear bezel on the chassis [3] as shown in the previous figure.
4. Fasten the four Phillips screws inside the drive bays [4] as shown in the previous figure.
5. Fasten the three Phillips screws on the back of the ear bezel [5] as shown in the previous figure.
6. Replace the disk drives in the drive bays [6] as shown in the previous figure.  
Use the marks to ensure that you return each drive to its original bay.
7. Return the system to operation.
  - a. Reinstall the system into the rack.  
See the *Oracle Database Appliance Owner's Guide* for instructions.
  - b. Reconnect the power cords to the system and power on the system.  
See [Powering On Oracle Database Appliance Version 1](#) (page A-98).

## A.4.8 Servicing Server Node Cables

Perform tasks for servicing the Oracle Database Appliance Version 1 server node cables.

### Note:

Information in this appendix does NOT apply to Oracle Database Appliance X7 series, Oracle Database Appliance X6 series, or Oracle Database Appliance X3-2/X4-2/X5-2. Refer to the preceding chapters in this document for information on servicing those systems.

The internal server node cables are FRUs and can only be replaced by an Oracle-qualified service technician.

### Caution:

**Equipment damage.** These procedures require that you handle components that are sensitive to static discharge. This sensitivity can cause the component to fail. To avoid damage, ensure that you follow antistatic practices.

- [Servicing Fan Power Cables \(FRU\)](#) (page A-79)  
Learn about servicing fan cables in an Oracle Database Appliance Version 1 server node.
- [Servicing the HBA PCIe Card Cables \(FRU\)](#) (page A-81)  
Learn about servicing HBA PCIe card cables in an Oracle Database Appliance Version 1 server node.

- [Servicing the SAS Expander Cable \(FRU\)](#) (page A-85)  
Learn about servicing SAS expander cables in an Oracle Database Appliance Version 1 server node.
- [Servicing the Boot Disk Backplane Cables \(FRU\)](#) (page A-87)  
Learn about servicing boot disk backplane cables in an Oracle Database Appliance Version 1.

### A.4.8.1 Servicing Fan Power Cables (FRU)

Learn about servicing fan cables in an Oracle Database Appliance Version 1 server node.

 **Note:**

Information in this appendix does NOT apply to Oracle Database Appliance X7 series, Oracle Database Appliance X6 series, or Oracle Database Appliance X3-2/X4-2/X5-2. Refer to the preceding chapters in this document for information on servicing those systems.

Each Oracle Database Appliance Version 1 server node has two fans and each fan has a separate power cable.

 **Caution:**

**Equipment damage.** These procedures require that you handle components that are sensitive to static discharge. This sensitivity can cause the component to fail. To avoid damage, ensure that you follow antistatic practices.

- [Remove Fan Power Cables](#) (page A-79)  
How to remove fan cables in an Oracle Database Appliance Version 1 server node.
- [Install Fan Power Cables](#) (page A-80)  
How to install fan cables in an Oracle Database Appliance Version 1 server node.

#### A.4.8.1.1 Remove Fan Power Cables

How to remove fan cables in an Oracle Database Appliance Version 1 server node.

 **Note:**

Information in this appendix does NOT apply to Oracle Database Appliance X7 series, Oracle Database Appliance X6 series, or Oracle Database Appliance X3-2/X4-2/X5-2. Refer to the preceding chapters in this document for information on servicing those systems.

1. Prepare the server node for service.
  - a. Attach an antistatic wrist strap.  
See [Performing Electrostatic Discharge and Antistatic Prevention Measures](#) (page A-8).
  - b. Remove the server node from the system.  
Power is removed from the server node when you remove it from the system. See [Removing Server Nodes From the System Chassis](#) (page A-9).
  - c. Remove the server node top cover.  
See [Removing the Server Node Top Cover](#) (page A-11).
2. Disconnect the fan power cables [1] and remove them from the server node [2] as shown in the following figure.

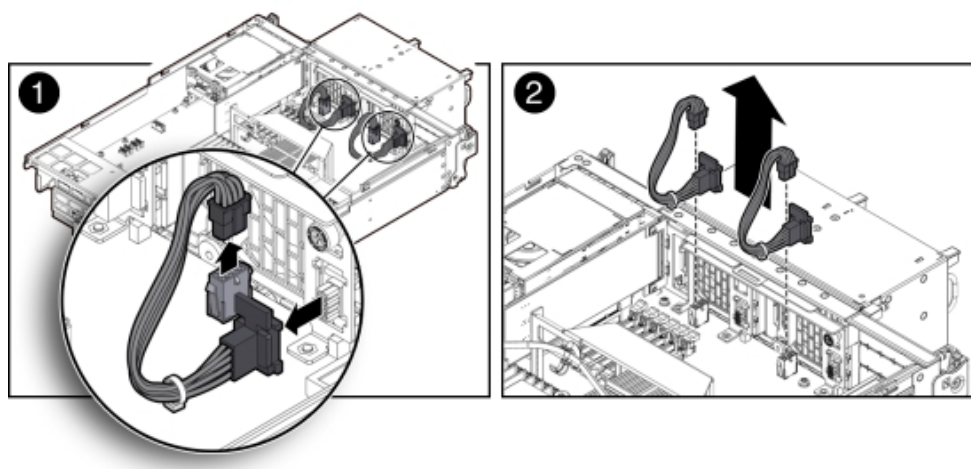

#### A.4.8.1.2 Install Fan Power Cables

How to install fan cables in an Oracle Database Appliance Version 1 server node.

 **Note:**

Information in this appendix does NOT apply to Oracle Database Appliance X7 series, Oracle Database Appliance X6 series, or Oracle Database Appliance X3-2/X4-2/X5-2. Refer to the preceding chapters in this document for information on servicing those systems.

1. Reconnect the fan power cables.
2. Return the server node to operation.
  - a. Install the server node top cover.  
See [Installing the Server Node Top Cover](#) (page A-95).
  - b. Install the server node into the system.  
See [Installing a Server Node Into the System Chassis](#) (page A-96).

- c. Power on the server node.

See [Powering On Oracle Database Appliance Version 1](#) (page A-98).

## A.4.8.2 Servicing the HBA PCIe Card Cables (FRU)

Learn about servicing HBA PCIe card cables in an Oracle Database Appliance Version 1 server node.

### Note:

Information in this appendix does NOT apply to Oracle Database Appliance X7 series, Oracle Database Appliance X6 series, or Oracle Database Appliance X3-2/X4-2/X5-2. Refer to the preceding chapters in this document for information on servicing those systems.

The Oracle Database Appliance Version 1 PCIe card cables are used to connect the internal PCIe card, the primary HBA and a riser-mounted PCIe card, and the secondary HBA to the motherboard. See the following sections for instructions.

The PCIe card cables are FRUs and can only be replaced by an Oracle-qualified service technician.

### Caution:

**Equipment damage.** These procedures require that you handle components that are sensitive to static discharge. This sensitivity can cause the component to fail. To avoid damage, ensure that you follow antistatic practices.

- [Remove PCIe Card Cables From Primary HBA PCIe Card](#) (page A-82)  
How to remove the primary HBA cables in an Oracle Database Appliance Version 1 server node.
- [Install PCIe Card Cables From Primary HBA PCIe Card](#) (page A-83)  
How to install the primary HBA cables in an Oracle Database Appliance Version 1 server node.
- [Remove PCIe Card Cables From Secondary HBA PCIe Card](#) (page A-83)  
How to remove the secondary HBA cables in an Oracle Database Appliance Version 1 server node.
- [Install PCIe Card Cables From Secondary HBA PCIe Card](#) (page A-84)  
How to install the secondary HBA cables in an Oracle Database Appliance Version 1 server node.



### A.4.8.2.1 Remove PCIe Card Cables From Primary HBA PCIe Card

How to remove the primary HBA cables in an Oracle Database Appliance Version 1 server node.

 **Note:**

Information in this appendix does NOT apply to Oracle Database Appliance X7 series, Oracle Database Appliance X6 series, or Oracle Database Appliance X3-2/X4-2/X5-2. Refer to the preceding chapters in this document for information on servicing those systems.

1. Prepare the server node for service.
  - a. Attach an antistatic wrist strap.  
See [Performing Electrostatic Discharge and Antistatic Prevention Measures](#) (page A-8).
  - b. Remove the server node from the system.  
Power is removed from the server node when you remove it from the system. See [Removing Server Nodes From the System Chassis](#) (page A-9).
  - c. Remove the server node top cover.  
See [Removing the Server Node Top Cover](#) (page A-11).
2. Disconnect the primary HBA PCIe card cables and remove them from the server node.
  - a. Loosen the three green, captive Phillips screws that secure the server node's front cover and remove the cover [1] as shown in the following figure.

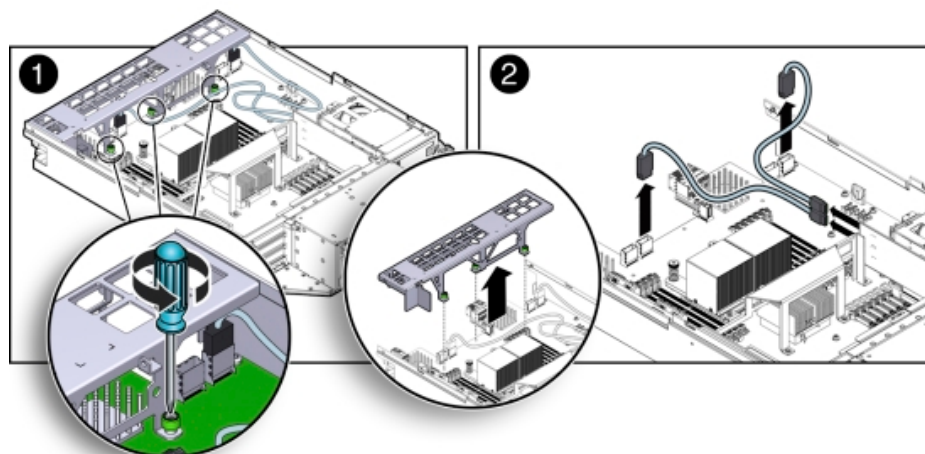

- b. Disconnect the two cables from the primary HBA PCIe card and remove the cables [2] as shown in the previous figure.

To remove each cable connector, push the connector inward, press down on the connector to release it, and pull the connector out.



### A.4.8.2.2 Install PCIe Card Cables From Primary HBA PCIe Card

How to install the primary HBA cables in an Oracle Database Appliance Version 1 server node.

 **Note:**

Information in this appendix does NOT apply to Oracle Database Appliance X7 series, Oracle Database Appliance X6 series, or Oracle Database Appliance X3-2/X4-2/X5-2. Refer to the preceding chapters in this document for information on servicing those systems.

1. Reconnect the PCIe card cables.
  - a. Reconnect the two PCIe card cables to the primary HBA PCIe card and the connectors on the motherboard [2].

Notice that there are two sets of connectors on the motherboard. Be sure to connect the cables to the connector on the right in each set (looking at the connectors from the rear of the server node).
  - b. Position the server node's front cover onto the server node and tighten the three green, captive Phillips screws that secure the server node's front cover to the motherboard [1].
2. Return the server node to operation.
  - a. Install the server node top cover.

See [Installing the Server Node Top Cover](#) (page A-95).
  - b. Install the server node into the system.

See [Installing a Server Node Into the System Chassis](#) (page A-96).
  - c. Power on the server node.

See [Powering On Oracle Database Appliance Version 1](#) (page A-98).

### A.4.8.2.3 Remove PCIe Card Cables From Secondary HBA PCIe Card

How to remove the secondary HBA cables in an Oracle Database Appliance Version 1 server node.

 **Note:**

Information in this appendix does NOT apply to Oracle Database Appliance X7 series, Oracle Database Appliance X6 series, or Oracle Database Appliance X3-2/X4-2/X5-2. Refer to the preceding chapters in this document for information on servicing those systems.

1. Prepare the server node for service.
  - a. Attach an antistatic wrist strap.

See [Performing Electrostatic Discharge and Antistatic Prevention Measures](#) (page A-8).

- b. Remove the server node from the system.

Power is removed from the server node when you remove it from the system. See [Removing Server Nodes From the System Chassis](#) (page A-9).

- c. Remove the server node top cover.

See [Removing the Server Node Top Cover](#) (page A-11).

2. Disconnect the PCIe card cables and remove them from the server node.

The Secondary HBA PCIe Card sits in the top slot on the PCIe riser (PCIe slot 2)

- a. Loosen the three green, captive Phillips screws that secure the server node's front cover and remove the cover [1] as shown in the following figure.

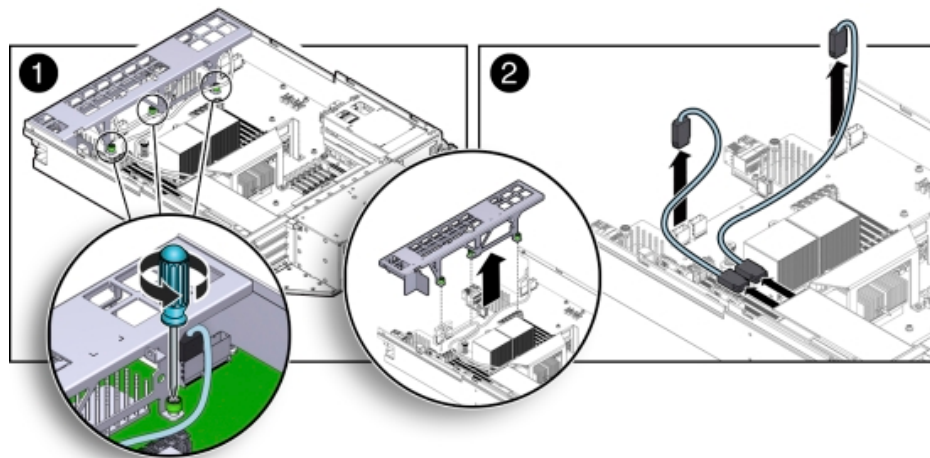

- b. Disconnect the two secondary HBA PCIe card cables and remove the cables [2] as shown in the previous figure.

To remove each cable connector, push the connector inward, press down on the connector to release it, and pull the connector out.

#### A.4.8.2.4 Install PCIe Card Cables From Secondary HBA PCIe Card

How to install the secondary HBA cables in an Oracle Database Appliance Version 1 server node.

##### Note:

Information in this appendix does NOT apply to Oracle Database Appliance X7 series, Oracle Database Appliance X6 series, or Oracle Database Appliance X3-2/X4-2/X5-2. Refer to the preceding chapters in this document for information on servicing those systems.

1. Reconnect the PCIe card cables.
  - a. Reconnect the two PCIe card cables between to the secondary PCIe card and the connectors on the motherboard [2].

The Secondary HBA PCIe Card sits in the top slot on the PCIe riser (PCIe slot 2)

Notice that there are two sets of connectors on the motherboard. Be sure to connect the cables to connector on the left in each set (looking at the connectors from the rear of the server node).

- b. Position the server node's front cover onto the server node and tighten the three green, captive Phillips screws that secure the server node's front cover to the motherboard [1].
2. Return the server node to operation.
    - a. Install the server node top cover.  
See [Installing the Server Node Top Cover](#) (page A-95).
    - b. Install the server node into the system.  
See [Installing a Server Node Into the System Chassis](#) (page A-96).
    - c. Power on the server node.  
See [Powering On Oracle Database Appliance Version 1](#) (page A-98).

### A.4.8.3 Servicing the SAS Expander Cable (FRU)

Learn about servicing SAS expander cables in an Oracle Database Appliance Version 1 server node.

#### Note:

Information in this appendix does NOT apply to Oracle Database Appliance X7 series, Oracle Database Appliance X6 series, or Oracle Database Appliance X3-2/X4-2/X5-2. Refer to the preceding chapters in this document for information on servicing those systems.

The SAS expander cable is a FRU and can only be replaced by an Oracle-qualified service technician.

#### Caution:

**Equipment damage.** These procedures require that you handle components that are sensitive to static discharge. This sensitivity can cause the component to fail. To avoid damage, ensure that you follow antistatic practices.

- [Remove SAS Expander Cable](#) (page A-86)  
How to remove the SAS expander cable in an Oracle Database Appliance Version 1 server node.
- [Install SAS Expander Cable](#) (page A-87)  
How to install the SAS expander cable in an Oracle Database Appliance Version 1 server node.

### A.4.8.3.1 Remove SAS Expander Cable

How to remove the SAS expander cable in an Oracle Database Appliance Version 1 server node.

 **Note:**

Information in this appendix does NOT apply to Oracle Database Appliance X7 series, Oracle Database Appliance X6 series, or Oracle Database Appliance X3-2/X4-2/X5-2. Refer to the preceding chapters in this document for information on servicing those systems.

1. Prepare the server node for service.
  - a. Attach an antistatic wrist strap.  
See [Performing Electrostatic Discharge and Antistatic Prevention Measures](#) (page A-8).
  - b. Remove the server node from the system.  
Power is removed from the server node when you remove it from the system. See [Removing Server Nodes From the System Chassis](#) (page A-9).
  - c. Remove the server node top cover.  
See [Removing the Server Node Top Cover](#) (page A-11).
  - d. Remove the PCIe riser.  
See [Remove PCIe Riser From Server Nodes](#) (page A-38).
2. Disconnect the SAS expander cable and remove it from the server node.
  - a. Loosen the three green, captive Phillips screws that secure the server node's front cover and remove the cover [1] as shown in the following figure.

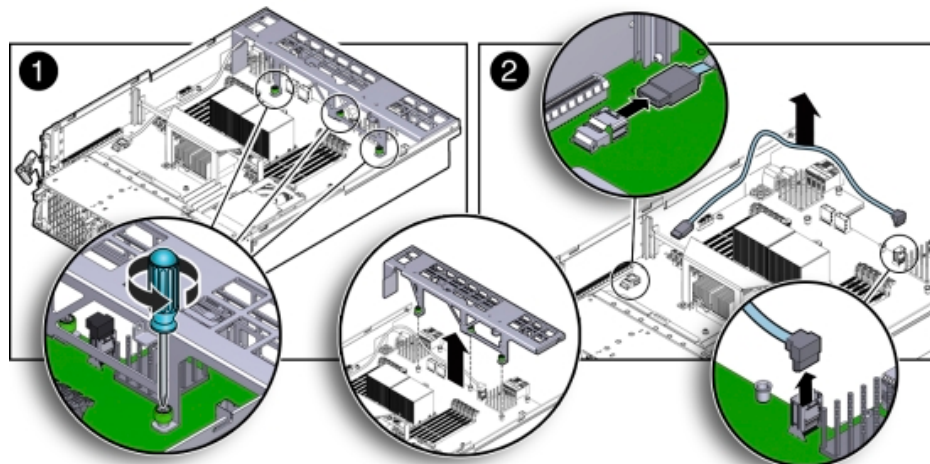

- b. Disconnect both cable connectors from the motherboard and remove the cable [2] as shown in the previous figure.

Push the connector inward, press down on the connector to release it, and pull the connector out.

### A.4.8.3.2 Install SAS Expander Cable

How to install the SAS expander cable in an Oracle Database Appliance Version 1 server node.

 **Note:**

Information in this appendix does NOT apply to Oracle Database Appliance X7 series, Oracle Database Appliance X6 series, or Oracle Database Appliance X3-2/X4-2/X5-2. Refer to the preceding chapters in this document for information on servicing those systems.

1. Reconnect the SAS expander cable.
  - a. Reconnect the SAS expander cable connectors to the motherboard [2].
  - b. Position the server node's front cover onto the server node and tighten the three green, captive Phillips screws that secure the server node's front cover to the motherboard [1].
2. Return the server node to operation.
  - a. Install the PCIe riser.  
See [Install PCIe Riser in Server Nodes](#) (page A-40).
  - b. Install the server node top cover.  
See [Installing the Server Node Top Cover](#) (page A-95).
  - c. Install the server node into the system.  
See [Installing a Server Node Into the System Chassis](#) (page A-96).
  - d. Power on the server node.  
See [Powering On Oracle Database Appliance Version 1](#) (page A-98).

### A.4.8.4 Servicing the Boot Disk Backplane Cables (FRU)

Learn about servicing boot disk backplane cables in an Oracle Database Appliance Version 1.

 **Note:**

Information in this appendix does NOT apply to Oracle Database Appliance X7 series, Oracle Database Appliance X6 series, or Oracle Database Appliance X3-2/X4-2/X5-2. Refer to the preceding chapters in this document for information on servicing those systems.

The SAS expander cable is a FRU and can only be replaced by an Oracle-qualified service technician.

 **Caution:**

**Equipment damage.** These procedures require that you handle components that are sensitive to static discharge. This sensitivity can cause the component to fail. To avoid damage, ensure that you follow antistatic practices.

- [Remove Boot Disk Backplane Cables](#) (page A-88)  
How to remove the boot disk backplane cables in an Oracle Database Appliance Version 1 server node.
- [Install Boot Disk Backplane Cables](#) (page A-89)  
How to install the boot disk backplane cables in an Oracle Database Appliance Version 1 server node.

#### A.4.8.4.1 Remove Boot Disk Backplane Cables

How to remove the boot disk backplane cables in an Oracle Database Appliance Version 1 server node.

 **Note:**

Information in this appendix does NOT apply to Oracle Database Appliance X7 series, Oracle Database Appliance X6 series, or Oracle Database Appliance X3-2/X4-2/X5-2. Refer to the preceding chapters in this document for information on servicing those systems.

1. Prepare the server node for service.
  - a. Attach an antistatic wrist strap.  
See [Performing Electrostatic Discharge and Antistatic Prevention Measures](#) (page A-8).
  - b. Remove the server node from the system.  
Power is removed from the server node when you remove it from the system. See [Removing Server Nodes From the System Chassis](#) (page A-9).
  - c. Remove the server node top cover.  
See [Removing the Server Node Top Cover](#) (page A-11).
2. Disconnect the power cable and hard disk drive (HDD) cables and remove them from the server node.
  - a. Disconnect the power cable and HDD cables from the motherboard [1] as shown in the following figure.



## A.4.9 Servicing the Motherboard Assembly (FRU)

Learn about servicing the motherboard in an Oracle Database Appliance Version 1 server node.

 **Note:**

Information in this appendix does NOT apply to Oracle Database Appliance X7 series, Oracle Database Appliance X6 series, or Oracle Database Appliance X3-2/X4-2/X5-2. Refer to the preceding chapters in this document for information on servicing those systems.

Each Oracle Database Appliance Version 1 server node has a motherboard assembly. The service strategy for the motherboard is to remove the replaceable components from the server node and then return the server node with the motherboard in place to Oracle for repair or replacement.

The motherboard assembly is a FRU and can only be replaced by Oracle Service personnel.

 **Caution:**

**Equipment damage.** These procedures require that you handle components that are sensitive to static discharge. This sensitivity can cause the component to fail. To avoid damage, ensure that you follow antistatic practices.

The following figure shows the components that must be removed from the server node.



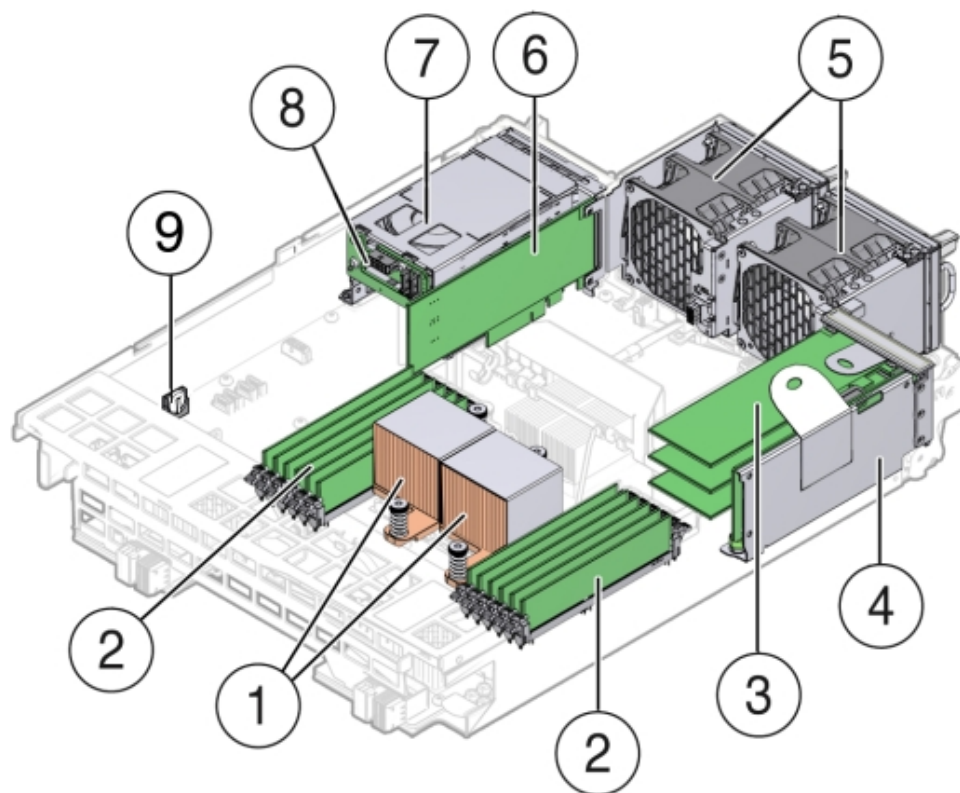

Callout	Description
---------	-------------

1	CPUs and Heatsinks
2	Memory modules (DIMMs)
3	PCIe Cards mounted on the PCIe Riser
4	PCIe Riser
5	Fan Modules (2)
6	Internally Mounted PCIe Card
7	Boot Disk Drives (2)
8	Boot Disk Drive Backplane
9	Battery

- [Remove Replaceable Components From Motherboard Assembly](#) (page A-92)  
 How to remove components from a server node in order to replace the motherboard assembly in an Oracle Database Appliance Version 1.
- [Install Replaceable Components in Motherboard Assembly](#) (page A-93)  
 How to install components from a server node to a new motherboard assembly in an Oracle Database Appliance Version 1.

## A.4.9.1 Remove Replaceable Components From Motherboard Assembly

How to remove components from a server node in order to replace the motherboard assembly in an Oracle Database Appliance Version 1.

### Note:

Information in this appendix does NOT apply to Oracle Database Appliance X7 series, Oracle Database Appliance X6 series, or Oracle Database Appliance X3-2/X4-2/X5-2. Refer to the preceding chapters in this document for information on servicing those systems.

1. Prepare the server node for service.
  - a. Attach an antistatic wrist strap.  
See [Performing Electrostatic Discharge and Antistatic Prevention Measures](#) (page A-8).
  - b. Remove the server node from the system.  
Power is removed from the server node when you remove it from the system. See [Removing Server Nodes From the System Chassis](#) (page A-9).
  - c. Remove the server node top cover.  
See [Removing the Server Node Top Cover](#) (page A-11).
2. With the exception the SAS expander cable, disconnect and remove all internal cables from the server node.

### Note:

To identify the SAS expander cable, see [Install SAS Expander Cable](#) (page A-87).

The cables for the fans, the primary and secondary HBA PCIe cards, and the boot disk backplane must be removed.

- Fan power cables  
See [Remove Fan Power Cables](#) (page A-79).
- Primary HBA PCIe card data cables  
See [Remove PCIe Card Cables From Primary HBA PCIe Card](#) (page A-82).
- Secondary HBA PCIe card data cables  
See [Remove PCIe Card Cables From Secondary HBA PCIe Card](#) (page A-83).

 **Caution:**

**Equipment damage.** The HBA data cables are delicate. Ensure that they are removed and safely out of the way when servicing the motherboard.

- Boot disk board cables.  
See [Remove Boot Disk Backplane Cables](#) (page A-88).
- 3. Remove the following components from the server node.
  - Fan modules  
[Remove a Fan Module](#) (page A-23).
  - Boot disk drives  
[Remove a Boot Drive](#) (page A-20).
  - Boot disk drive backplane  
[Remove Boot Disk Backplane](#) (page A-61).
  - Memory modules (DIMMS)  
[Remove Faulty DIMMs](#) (page A-32).
  - PCIe riser and attached PCIe cards  
[Remove PCIe Riser From Server Nodes](#) (page A-38).
  - CPUs  
[Remove Processor \(CPU\)](#) (page A-56).
  - Internal primary HBA PCIe card  
[Remove Primary HBA PCIe Card From Motherboard](#) (page A-46).
  - Battery  
[Remove Battery](#) (page A-50).

## A.4.9.2 Install Replaceable Components in Motherboard Assembly

How to install components from a server node to a new motherboard assembly in an Oracle Database Appliance Version 1.

 **Note:**

Information in this appendix does NOT apply to Oracle Database Appliance X7 series, Oracle Database Appliance X6 series, or Oracle Database Appliance X3-2/X4-2/X5-2. Refer to the preceding chapters in this document for information on servicing those systems.

1. Attach an antistatic wrist strap.  
See [Performing Electrostatic Discharge and Antistatic Prevention Measures](#) (page A-8).

2. Install the following components into the server node.
  - Fan modules  
See [Install a Fan Module](#) (page A-24).
  - Boot disk drives  
See [Install a Boot Drive](#) (page A-21).
  - Memory modules (DIMMS)  
See [Install DIMMs](#) (page A-35).
  - PCIe riser and attached PCIe cards  
See [Install PCIe Riser in Server Nodes](#) (page A-40).
  - CPUs  
See [Install Processor \(CPU\)](#) (page A-59).
  - Internal primary HBA PCIe card  
See [Install Primary HBA PCIe Card in Motherboard](#) (page A-47).
3. Reconnect and install the following cables.
  - Fan module power cables.  
See [Servicing the Fan Power Cables \(FRU\)](#) (page A-79).
  - Internal PCIe card data cables.  
See [Servicing the PCIe Card Cables \(FRU\)](#) (page A-81).

 **Caution:**

**Equipment damage.** The disk drive data cables are delicate. Handle them carefully.

- Boot disk backplane cables.  
See [Servicing the Boot Disk Backplane Cables \(FRU\)](#) (page A-87).
4. Return the server node to operation.
    - a. Install the server node top cover.  
See [Installing the Server Node Top Cover](#) (page A-95).
    - b. Install the server node into the system.  
See [Installing a Server Node Into the System Chassis](#) (page A-96).
    - c. Reconnect all external data cables from the PCIe card(s) that are installed in the PCIe riser.
    - d. Power on the server node.  
See [Powering On Oracle Database Appliance Version 1](#) (page A-98).

## A.5 Returning the Appliance to Operation

Perform tasks for returning the Oracle Database Appliance Version 1 to operation after servicing.

 **Note:**

Information in this appendix does NOT apply to Oracle Database Appliance X7 series, Oracle Database Appliance X6 series, or Oracle Database Appliance X3-2/X4-2/X5-2. Refer to the preceding chapters in this document for information on servicing those systems.

This section describes returning Oracle Database Appliance Version 1 to operation after servicing.

- [Installing the Server Node Top Cover](#) (page A-95)  
Learn about replacing an Oracle Database Appliance Version server node top cover.
- [Installing a Server Node Into the System Chassis](#) (page A-96)  
Learn about installing an Oracle Database Appliance Version 1 server node in the chassis.
- [Powering On Oracle Database Appliance Version 1](#) (page A-98)  
Learn about powering on an Oracle Database Appliance Version 1.

## A.5.1 Installing the Server Node Top Cover

Learn about replacing an Oracle Database Appliance Version server node top cover.

 **Note:**

Information in this appendix does NOT apply to Oracle Database Appliance X7 series, Oracle Database Appliance X6 series, or Oracle Database Appliance X3-2/X4-2/X5-2. Refer to the preceding chapters in this document for information on servicing those systems.

 **Caution:**

**Hazardous voltage present.** Do not run the system with the top cover removed.

 **Caution:**

**Equipment damage.** Install the top cover properly before starting the system.

If you removed the top cover from an Oracle Database Appliance Version 1 server node, perform the following procedure to replace it.

- [Install Server Node Top Cover](#) (page A-96)  
How to install a top cover for an Oracle Database Appliance Version 1 server node.

## A.5.1.1 Install Server Node Top Cover

How to install a top cover for an Oracle Database Appliance Version 1 server node.

### Note:

Information in this appendix does NOT apply to Oracle Database Appliance X7 series, Oracle Database Appliance X6 series, or Oracle Database Appliance X3-2/X4-2/X5-2. Refer to the preceding chapters in this document for information on servicing those systems.

1. Place the top cover down on the server node [1] as shown in the following figure.  
The cover should hang over the front of the chassis by 0.5 inches (12.7 mm) and all six of the standoffs on the underside of the cover (three on each side) should fit into the slots on the top of the chassis side walls.

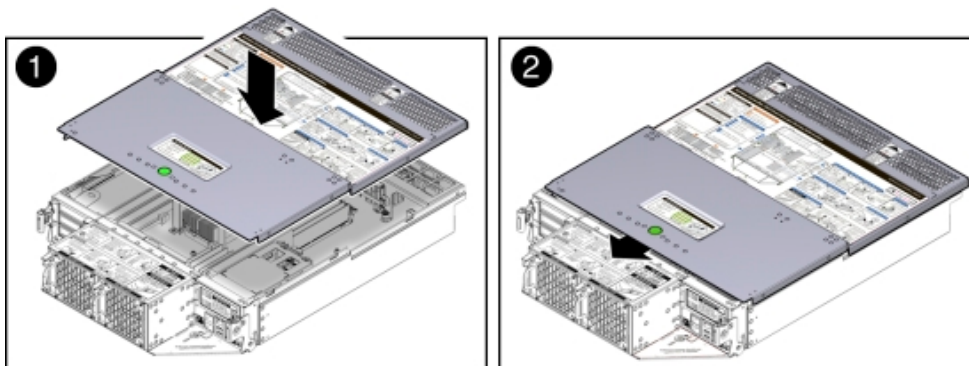

2. Slide the top cover toward the rear of the server node until it seats [2] as shown in the previous figure.

## A.5.2 Installing a Server Node Into the System Chassis

Learn about installing an Oracle Database Appliance Version 1 server node in the chassis.

### Note:

Information in this appendix does NOT apply to Oracle Database Appliance X7 series, Oracle Database Appliance X6 series, or Oracle Database Appliance X3-2/X4-2/X5-2. Refer to the preceding chapters in this document for information on servicing those systems.

If you removed a server node from an Oracle Database Appliance Version 1, perform the following procedure to reinstall it.

- [Install Server Node Into System Chassis](#) (page A-97)  
How to install a server node into an Oracle Database Appliance Version 1 chassis.

### A.5.2.1 Install Server Node Into System Chassis

How to install a server node into an Oracle Database Appliance Version 1 chassis.

 **Note:**

Information in this appendix does NOT apply to Oracle Database Appliance X7 series, Oracle Database Appliance X6 series, or Oracle Database Appliance X3-2/X4-2/X5-2. Refer to the preceding chapters in this document for information on servicing those systems.

 **Note:**

Replacing a server node FRU with a new server node is a service activity that must be performed by an Oracle-qualified service technician. The customer may remove the server node to service other customer serviceable components in the server node.

1. Before inserting the server node into the system chassis, ensure that both release latches on the rear of the server node are in the open position.
2. Slide the server node into the rear of the system chassis [1] until the server node is close enough for its release latches come in contact with and engage the chassis [2] as shown in the following figure.

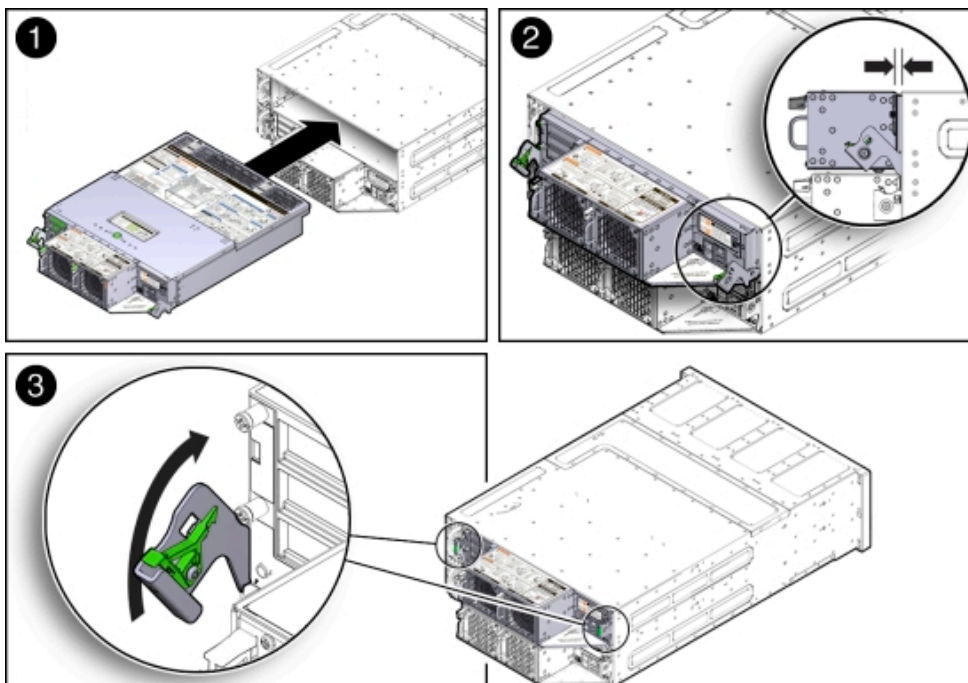

3. To re-seat the server node in the system chassis, grasp both release latches, one on each side of the server node, and push them upward simultaneously to the closed position [3] as shown in the previous figure.

**Caution:**

**Equipment damage.** Always use the release latches to re-seat the server node into the system chassis as described in this procedure. Failure to do so might damage the connectors on the front of the server node and/or the connectors on the disk midplane module.

4. Reinstall the system chassis into the rack.

Follow the instructions listed in the "Inserting Oracle Database Appliance Version 1 Into a Rack" section in the *Oracle Database Appliance Owner's Guide*.

## A.5.3 Powering On Oracle Database Appliance Version 1

Learn about powering on an Oracle Database Appliance Version 1.

**Note:**

Information in this appendix does NOT apply to Oracle Database Appliance X7 series, Oracle Database Appliance X6 series, or Oracle Database Appliance X3-2/X4-2/X5-2. Refer to the preceding chapters in this document for information on servicing those systems.

Each server node is powered on separately.



 **Note:**

To use Oracle ILOM to power on a server node, ensure that you have performed its initial configuration as described in "Connecting and Configuring Oracle ILOM" in the *Oracle Database Appliance Getting Started Guide*.

- [Power On Oracle Database Appliance Version 1](#) (page A-99)  
How to power on an Oracle Database Appliance Version 1.

### A.5.3.1 Power On Oracle Database Appliance Version 1

How to power on an Oracle Database Appliance Version 1.

 **Note:**

Information in this appendix does NOT apply to Oracle Database Appliance X7 series, Oracle Database Appliance X6 series, or Oracle Database Appliance X3-2/X4-2/X5-2. Refer to the preceding chapters in this document for information on servicing those systems.

 **Note:**

Replacing a server node FRU with a new server node is a service activity that must be performed by an Oracle-qualified service technician. The customer may remove the server node to service other customer serviceable components in the server node.

1. Ensure that the power cord (or cords) are connected to the power supplies on the rear of the server node that was serviced.

Once plugged in, the server node goes into the standby power state. The SP status LED on the front panel of the server node lights green and goes from slow blink to steady on. The Power/OK LED on the front panel of the server node lights green and goes to standby blink. It might take about five minutes for the LED to reach standby blink after the power cord is inserted.

For the location of the SP status LED and Power/OK LED, see [Oracle Database Appliance Version 1 Status Indicators](#) (page 1-43).

Standby power state indicates that the server node's service processor is active, but the server node host is powered off.

2. Power on a server node by performing one of the following procedures:

 **Note:**

If you powered off a single server node without shutting down the appliance, perform this step only for that server node. If you shut down the appliance completely, then perform this step for both server nodes.

- Using the server node's Power button: Momentarily press and release the recessed Power button on the front panel [1] as shown in the following figure.

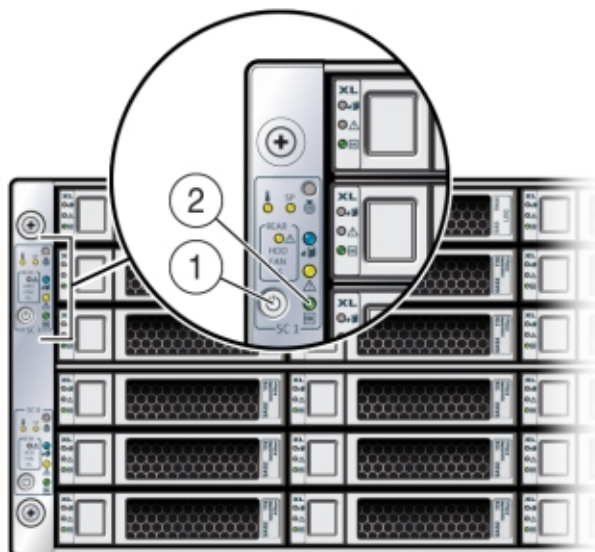

On the server node, the green Power/OK LED (see [2] in the previous figure) blinks while the server node is booting, and remains steady on when the server node is operational.

- Using the Oracle ILOM web interface:
  - a. Open a browser and enter the server node's service processor IP address in the browser's address field.
  - b. At the log in page, type a user name (the account must have Reset and Host Control (r) privileges) and password, and click the Log In button.
  - c. Go to Remote Power Control and select **Power On** from the Select Action list box and then click Save and OK.

On the server node, the green Power/OK LED [2] blinks while the server node is booting, and remains steady on when the server node is operational.

- Using the Oracle ILOM CLI:
  - a. Log in to Oracle ILOM using an ssh client. Type:

```
$ ssh username@sp_ip_address
```

Where *username* is a user account name with Reset and Host Control (r) privileges and *sp\_ip\_address* is the IP address of the server node service processor.

- b. When prompted, enter the user account password.
- c. Enter the command to power on the server node:

```
-> start /SYS
```

On the server node, the green Power/OK LED [2] blinks while the server node is booting, and remains steady on when the server node is operational.

## A.6 Server Node Basic Input/Output System (BIOS)

Learn about the Oracle Database Appliance Version 1 BIOS.

### Note:

Information in this appendix does NOT apply to Oracle Database Appliance X7 series, Oracle Database Appliance X6 series, or Oracle Database Appliance X3-2/X4-2/X5-2. Refer to the preceding chapters in this document for information on servicing those systems.

This section describes the Oracle Database Appliance Version 1 BIOS utility.

All settings are set to the optimal defaults at startup.

### Caution:

You should not configure system BIOS settings. Oracle Database Appliance patch software will do this for you. The only time you might need to configure BIOS settings would be if requested to do so by Oracle Service.

- [BIOS Booting and Setup](#) (page A-102)  
Learn about the power-on sequence and tests performed by BIOS during Oracle Database Appliance Version 1 bootup.
- [Clearing Server Node CMOS NVRAM](#) (page A-107)  
Learn about clearing CMOS for an Oracle Database Appliance Version 1 server node.
- [Ethernet Port Naming and Boot Order](#) (page A-109)  
Learn about Ethernet port naming and boot order for an Oracle Database Appliance Version 1.
- [Configuring Support for TPM](#) (page A-110)  
Learn about Trusted Platform Module for an Oracle Database Appliance Version 1 server node.
- [Configuring SP LAN Settings](#) (page A-115)  
Learn about configuring the service processor LAN settings for an Oracle Database Appliance Version 1 server node.

- [Configuring Option ROM Settings in BIOS](#) (page A-117)  
Learn about configuring option ROM for an Oracle Database Appliance Version 1 server node.
- [BIOS Setup Utility Hot Keys](#) (page A-118)  
Learn about BIOS Setup hot keys for an Oracle Database Appliance Version 1.
- [Accessing the BIOS Setup Utility Menus](#) (page A-119)  
Learn how to access BIOS Setup for an Oracle Database Appliance Version 1 server node.
- [BIOS Setup Utility Screens](#) (page A-122)  
Learn about BIOS Setup utility screens for an Oracle Database Appliance Version 1 server node.

## A.6.1 BIOS Booting and Setup

Learn about the power-on sequence and tests performed by BIOS during Oracle Database Appliance Version 1 bootup.

### Note:

Information in this appendix does NOT apply to Oracle Database Appliance X7 series, Oracle Database Appliance X6 series, or Oracle Database Appliance X3-2/X4-2/X5-2. Refer to the preceding chapters in this document for information on servicing those systems.

- [Default BIOS Power-On Self-Test \(POST\) Events](#) (page A-102)  
Learn about the default POST events for an Oracle Database Appliance Version 1.
- [BIOS POST F1 and F2 Errors](#) (page A-104)  
Learn about POST F1 and F2 errors for an Oracle Database Appliance Version 1.
- [How BIOS POST Memory Testing Works](#) (page A-106)  
Learn about POST memory tests for an Oracle Database Appliance Version 1.

### A.6.1.1 Default BIOS Power-On Self-Test (POST) Events

Learn about the default POST events for an Oracle Database Appliance Version 1.

### Note:

Information in this appendix does NOT apply to Oracle Database Appliance X7 series, Oracle Database Appliance X6 series, or Oracle Database Appliance X3-2/X4-2/X5-2. Refer to the preceding chapters in this document for information on servicing those systems.

When an Oracle Database Appliance Version 1 server node (also called a system controller) starts, the BIOS performs a power-on self-test that checks the hardware to ensure that all components are present and functioning properly. The following table identifies the events that can occur during BIOS POST, as well as specifies whether these events can prevent the host from powering-on.

Event	Cause	Boot Continues on Host?
User password violation	Attempt to enter password fails three times	No
Setup password violation	Attempt to enter password fails three times	No
Correctable ECC	Memory Correctable ECC (error correction code) error is detected	Does not apply
Uncorrectable ECC	Memory Uncorrectable ECC error is detected	Does not apply
No system memory	No physical memory is detected in the system	No
No usable system memory	All installed memory has experienced an unrecoverable failure	No
Hard disk controller failure	No disk controller is found	Yes
Keyboard failure	Keyboard cannot be initialized	Yes
Boot media failure	No removable boot media is found	Yes
No video device	No video controller is found	No
Firmware (BIOS) ROM corruption	BIOS checksum fails and the boot block is not corrupted	No
System restart	System boot is initiated	Yes
Initiated by hard reset	Boot process is started by hard reset	Yes
Memory initialization	Memory sizing is occurring System firmware progress	Does not apply
Primary processor initialization	Primary CPU initialization System firmware progress	Does not apply
Initiated by warm reset	Boot process is started by warm reset	Does not apply
Embedded controller management	Management controller initialization	Does not apply
Secondary processor(s) initialization	Secondary CPU initialization asserted System firmware progress	Does not apply
Video initialization	When BIOS initializes keyboard	Does not apply
Keyboard controller initialization	When BIOS initializes keyboard	Does not apply
Option ROM initialization	BIOS initializes Option ROMs System firmware progress	Does not apply
Option ROM space exhausted	BIOS cannot install an Option ROM (typically a plug-in card driver) into memory from that device preventing booting	Yes
User initiated system set up	User initiated access to BIOS Setup Utility System firmware progress	Does not apply
User initiated boot to OS	System boot is initiated System firmware progress	Does not apply
No bootable media	No media from which to boot	No

Event	Cause	Boot Continues on Host?
PXE server not found	Boot error - PXE server not found F12 key was pressed but BIOS fails to boot from PXE server	No. BIOS tries next boot device.
ACPI Power state	Soft-off power applied	Does not apply

## A.6.1.2 BIOS POST F1 and F2 Errors

Learn about POST F1 and F2 errors for an Oracle Database Appliance Version 1.

### Note:

Information in this appendix does NOT apply to Oracle Database Appliance X7 series, Oracle Database Appliance X6 series, or Oracle Database Appliance X3-2/X4-2/X5-2. Refer to the preceding chapters in this document for information on servicing those systems.

Each Oracle Database Appliance Version 1 power-on-self-test (POST) diagnostic is a low-level test designed to detect faults in a specific hardware component. If the POST diagnostic discloses an F1 or F2 error, it typically reports the following information about the error:

- Type of error detected
- When or where the error occurred

The following table lists some of the F1 and F2 error messages that could appear during the POST diagnostics along with instructions for how to possibly resolve the error reported.

BIOS POST Error Message	Error Type	Resolution
Uncorrectable Error Detected on Last Boot:IOH(0) Protocol Error (Please Check SP Log for more Details)	IOH error	<ul style="list-style-type: none"> <li>• Press F1 to continue.</li> <li>• Check the SP event log in Oracle ILOM for more details.</li> </ul>
Uncorrectable Error Detected on Last Boot:IOH(0) QPI [x] Error (Please Check SP Log for more Details)	IOH error	<ul style="list-style-type: none"> <li>• Press F1 to continue.</li> <li>• Check the fault management function and the SP event log in Oracle ILOM for more details.</li> </ul> <p>Where QPI [x] equals 0 for QPI Link 0 or 1 for QPI Link 1.</p>
Uncorrectable Error Detected on Last Boot:IOH(0) PCI-E [x] Error (Please Check SP Log for more Details)	IOH error	<ul style="list-style-type: none"> <li>• Press F1 to continue.</li> <li>• Check the fault management function and the SP event log in Oracle ILOM for more details.</li> </ul> <p>Where PCI-E [x] port number can range from 1 to 10 depending on the PCI root port on IOH.</p>

BIOS POST Error Message	Error Type	Resolution
Uncorrectable Error Detected on Last Boot:IOH(0) ESI Error (Please Check SP Log for more Details)	IOH error	<ul style="list-style-type: none"> <li>Press F1 to continue.</li> <li>Check the fault management function and the SP event log in Oracle ILOM for more details.</li> </ul>
Uncorrectable Error Detected on Last Boot:IOH(0) Thermal Error (Please Check SP Log for more Details)	IOH error	<ul style="list-style-type: none"> <li>Press F1 to continue.</li> <li>Check the fault management function and the SP event log in Oracle ILOM for more details.</li> </ul>
Uncorrectable Error Detected on Last Boot:IOH(0) DMA Error (Please Check SP Log for more Details)	IOH error	<ul style="list-style-type: none"> <li>Press F1 to continue.</li> <li>Check the SP event log in Oracle ILOM for more details.</li> </ul>
Uncorrectable Error Detected on Last Boot:IOH(0) Miscellaneous Error (Please Check SP Log for more Details)	IOH error	<ul style="list-style-type: none"> <li>Press F1 to continue.</li> <li>Check the fault management function and the SP event log in Oracle ILOM for more details.</li> </ul>
Uncorrectable Error Detected on Last Boot:IOH(0) VTd Error (Please Check SP Log for more Details)	IOH error	<ul style="list-style-type: none"> <li>Press F1 to continue.</li> <li>Check the SP event log in Oracle ILOM for more details.</li> </ul>
BMC Not Responding	Oracle ILOM error	<ul style="list-style-type: none"> <li>Press F1 to continue.</li> </ul> <p>This error message might display if during the SP/BIOS communication an internal error occurs. This error might require you to restart the SP.</p>
<ul style="list-style-type: none"> <li>Primary Slave Hard Disk Error</li> <li>Primary Master Hard Disk Error</li> <li>Secondary Master Hard Disk Error</li> <li>Secondary Slave Hard Disk Error</li> </ul> <p>These error messages are not supported on Oracle Database Appliance.</p>	IDE/ATAPI error	<ul style="list-style-type: none"> <li>Press F1 to continue.</li> <li>Check the SP event log in Oracle ILOM for more details.</li> </ul> <p>These type of error messages display when the BIOS is attempting to configure IDE/ATAPI devices in POST.</p>
Timer Error	8254 timer error	<ul style="list-style-type: none"> <li>Press F1 to continue.</li> <li>Check the SP event log in Oracle ILOM for more details.</li> </ul> <p>This type of error typically indicates an error while programming the count register of channel 2 of the 8254 timer. This could indicate a problem with system hardware.</p>
RAM R/W test failed	Memory test failure	<ul style="list-style-type: none"> <li>Press F1 to continue.</li> <li>Check the SP event log in Oracle ILOM for more details.</li> </ul> <p>This type of error typically indicates that the RAM read/write test failed.</p>
KBC BAT Test failed	Keyboard controller basic assurance test error	<ul style="list-style-type: none"> <li>Press F1 to continue.</li> <li>Check the SP event log in Oracle ILOM for more details.</li> </ul> <p>Keyboard controller BAT test failed. This error might indicate a problem with keyboard controller initialization.</p>
Display memory test failed	Video display error	<ul style="list-style-type: none"> <li>Press F1 to continue.</li> <li>Check the SP event log in Oracle ILOM for more details.</li> </ul>

BIOS POST Error Message	Error Type	Resolution
CMOS Battery Low	CMOS battery error	<ul style="list-style-type: none"> <li>Press F2 to enter BIOS Setup Utility to load system defaults.</li> <li>Check the SP event log in Oracle ILOM for more details.</li> <li>If necessary, replace CMOS battery.</li> </ul>
<ul style="list-style-type: none"> <li>CMOS Checksum Bad</li> <li>CMOS Date/Time Not Set</li> </ul>	CMOS error	<ul style="list-style-type: none"> <li>Press F2 to enter BIOS Setup Utility to load system defaults.</li> <li>Check the SP event log in Oracle ILOM for more details.</li> </ul>
Password check failed	Password check error	<ul style="list-style-type: none"> <li>Press F1 to continue.</li> <li>Check the SP event log in Oracle ILOM for more details.</li> </ul> <p>This type of error indicates that the password entered does not match the password specified in the BIOS Setup Utility. This condition might occur for both Supervisor and User password verification.</p>
Keyboard/Interface Error	Keyboard controller error	<ul style="list-style-type: none"> <li>Press F1 to continue.</li> <li>Check the SP event log in Oracle ILOM for more details.</li> </ul> <p>This type of error indicates that the Keyboard Controller failure. This error might indicate a problem with system hardware.</p>
S.M.A.R.T error on the drive	S.M.A.R.T device error	<ul style="list-style-type: none"> <li>Press F1 to continue.</li> <li>Check the SP event log in Oracle ILOM for more details.</li> </ul> <p>Self-Monitoring, Analysis, and Reporting Technology (S.M.A.R.T.) failure messages might indicate the need to replace the storage device.</p>

### A.6.1.3 How BIOS POST Memory Testing Works

Learn about POST memory tests for an Oracle Database Appliance Version 1.



**Note:**

Information in this appendix does NOT apply to Oracle Database Appliance X7 series, Oracle Database Appliance X6 series, or Oracle Database Appliance X3-2/X4-2/X5-2. Refer to the preceding chapters in this document for information on servicing those systems.

The Oracle Database Appliance Version 1 BIOS POST memory testing is performed as follows:

1. The first megabyte of DRAM is tested by the BIOS before the BIOS code is copied from ROM to DRAM.
2. After existing out of DRAM, the BIOS performs a simple memory test (where a write/read of every location with the pattern 55aa55aa is performed).



 **Note:**

The simple memory test is performed only if Quick Boot is not enabled from the Boot Settings Configuration screen. Enabling Quick Boot causes the BIOS to skip the memory test.

3. The BIOS polls the memory controllers for both correctable and non-correctable memory errors and logs those errors into the SP.

## A.6.2 Clearing Server Node CMOS NVRAM

Learn about clearing CMOS for an Oracle Database Appliance Version 1 server node.

 **Note:**

Information in this appendix does NOT apply to Oracle Database Appliance X7 series, Oracle Database Appliance X6 series, or Oracle Database Appliance X3-2/X4-2/X5-2. Refer to the preceding chapters in this document for information on servicing those systems.

You can clear the CMOS NVRAM by pressing the CLR CMOS button on the Oracle Database Appliance Version 1 server node motherboard. This action sets the BIOS to defaults values, which clears the BIOS user and supervisor passwords.

You can also set or reset the BIOS password from the BIOS Setup Utility. See [BIOS Security Menu Screen](#) (page A-128) for more information.

 **Caution:**

**Data loss.** You should not perform this procedure unless instructed to do so by Oracle Service.

- [Reset BIOS Password and Clear CMOS NVRAM Using CLR CMOS Button](#) (page A-108)  
How to clear CMOS in an Oracle Database Appliance Version 1 server node.

## A.6.2.1 Reset BIOS Password and Clear CMOS NVRAM Using CLR CMOS Button

How to clear CMOS in an Oracle Database Appliance Version 1 server node.

 **Note:**

Information in this appendix does NOT apply to Oracle Database Appliance X7 series, Oracle Database Appliance X6 series, or Oracle Database Appliance X3-2/X4-2/X5-2. Refer to the preceding chapters in this document for information on servicing those systems.

 **Note:**

Clearing CMOS of a server node is a service activity that must be performed by an Oracle-qualified service technician. The customer may perform the procedure if directed to do so by Oracle Service.

1. Prepare the server node for service.
  - a. Attach an antistatic wrist strap.  
See [Performing Electrostatic Discharge and Antistatic Prevention Measures](#) (page A-8).
  - b. Remove the server node from the system.  
Power is removed from the server node when you remove it from the system. See [Removing Server Nodes From the System Chassis](#) (page A-9).
  - c. Remove the server node top cover.  
See [Removing the Server Node Top Cover](#) (page A-11).
2. Using a stylus, press and release the CLR CMOS button as shown in the following figure.

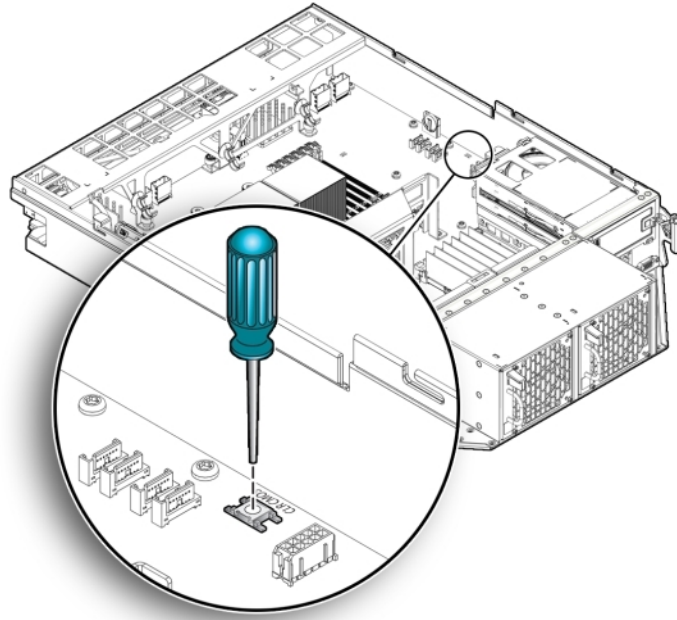

3. Return the server node to operation.
  - a. Install the server node top cover.  
See [Installing the Server Node Top Cover](#) (page A-95).
  - b. Install the server node into the system.  
See [Installing a Server Node Into the System Chassis](#) (page A-96).
  - c. Power on the server node.  
See [Powering On Oracle Database Appliance Version 1](#) (page A-98).  
When the server node powers on and boots, it displays a message that indicates that NVRAM has been cleared.  
The CMOS NVRAM, including the BIOS password is cleared to its default state.  
The default state for the BIOS passwords is that no password is required. To set a BIOS password, see [BIOS Security Menu Screen](#) (page A-128).
4. Verify that the Power/OK LED is lit on the server node.

## A.6.3 Ethernet Port Naming and Boot Order

Learn about Ethernet port naming and boot order for an Oracle Database Appliance Version 1.

### Note:

Information in this appendix does NOT apply to Oracle Database Appliance X7 series, Oracle Database Appliance X6 series, or Oracle Database Appliance X3-2/X4-2/X5-2. Refer to the preceding chapters in this document for information on servicing those systems.

Each Oracle Database Appliance Version 1 server node supports two 10/100/1000Base-T Gigabit Ethernet ports on the rear of the chassis. For port locations, see the *Oracle Database Appliance Owner's Guide*.

The device naming for the Ethernet interfaces is reported differently by different interfaces and operating systems. See the following table for the physical (BIOS) and logical (operating system) naming conventions used for each interface.

Interface	NET0	NET1
BIOS	NET0	NET1
Oracle Linux	eth0	eth1

The order in which the BIOS detects the Ethernet ports during boot time, and the corresponding drivers that control those ports, are listed below:

1. NET 0 (INTEL NIC 0)
2. NET 1 (INTEL NIC 1)

## A.6.4 Configuring Support for TPM

Learn about Trusted Platform Module for an Oracle Database Appliance Version 1 server node.



### Note:

Information in this appendix does NOT apply to Oracle Database Appliance X7 series, Oracle Database Appliance X6 series, or Oracle Database Appliance X3-2/X4-2/X5-2. Refer to the preceding chapters in this document for information on servicing those systems.

If you intend to use the Oracle Database Appliance Version 1 Trusted Platform Module (TPM) feature set, you must configure the server node to support this feature.

TPM enables you to administer the TPM security hardware in your server node. For additional information about implementing this feature, see the Trusted Platform Module Management documentation.

- [Configure TPM Support in BIOS](#) (page A-111)  
How to configure TPM in an Oracle Database Appliance Version 1 server node.

## A.6.4.1 Configure TPM Support in BIOS

How to configure TPM in an Oracle Database Appliance Version 1 server node.

 **Note:**

Information in this appendix does NOT apply to Oracle Database Appliance X7 series, Oracle Database Appliance X6 series, or Oracle Database Appliance X3-2/X4-2/X5-2. Refer to the preceding chapters in this document for information on servicing those systems.

1. Access the BIOS Setup Utility menus.

For instructions, see [Accessing the BIOS Setup Utility Menus](#) (page A-119).

When BIOS is started, the main BIOS Setup Utility top-level System Overview screen appears. See the following figure for an example:

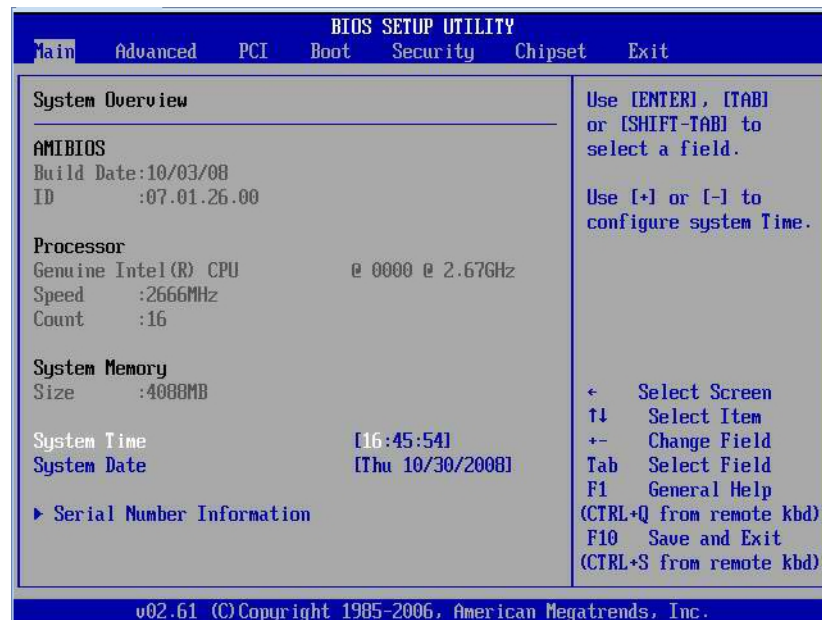

2. In the BIOS Setup Utility screen, select the Advanced menu option.

The Advanced Settings screen appears. See the following figure for an example:



- In the Advanced Settings screen, select Trusted Computing and press Enter. The Trusted Computing screen appears. See the following figure for an example:

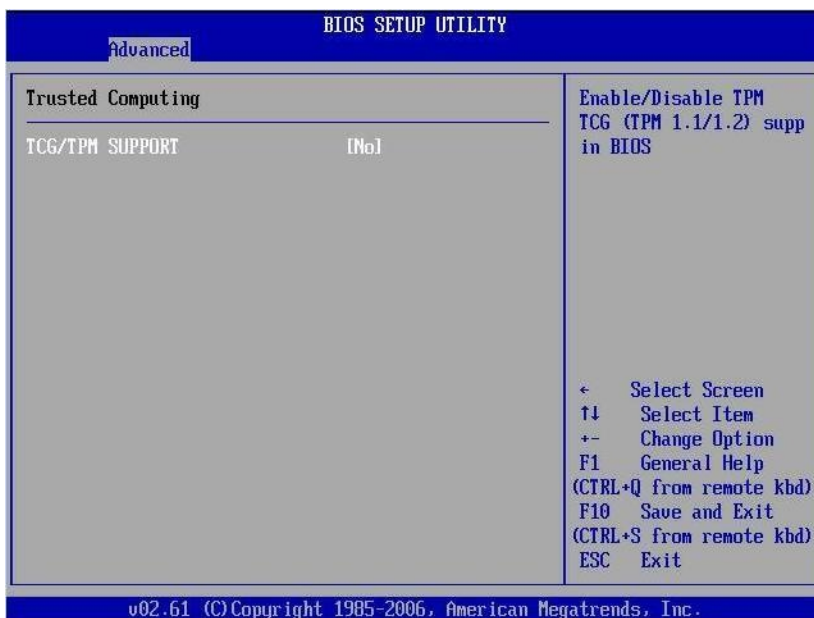

- In the Trusted Computing screen, select the TCG/TPM Support. A pop-up dialog box appears.
- In the pop-up dialog box, set the TCG/TPM Support option to Yes and click OK.

 **Note:**

Even if the TCG/TPM Support was already set to `Yes` in the dialog shown above, continue on and complete the remaining steps of this procedure to ensure that all TPM configuration requirements are satisfied.

The updated Trusted Computing dialog appears and shows that the TCG/TPM Support setting has changed to `Yes`. See the following figure for an example:

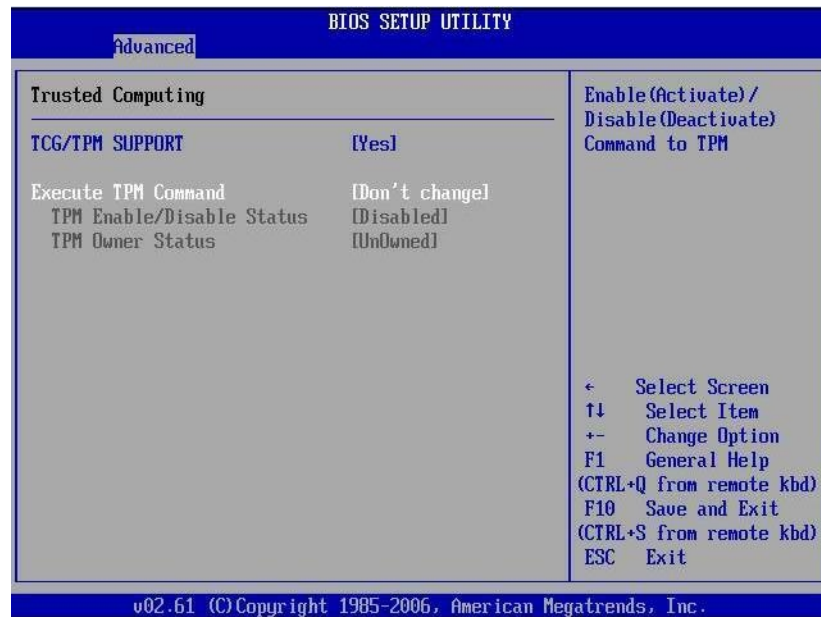

 **Note:**

In the above screen, the Execute TPM Command setting shows the default, `Don't Change`.

- In the Trusted Computing screen, select the Execute TPM Command option setting.

A pop-up dialog box appears.

- In the pop-up dialog box, set the Execute TPM Command option to `Enabled` and click `OK`.

The updated Trusted Computing screen appears and shows that the Execute TPM Command setting has changed to `Enabled`. See the following figure for an example:

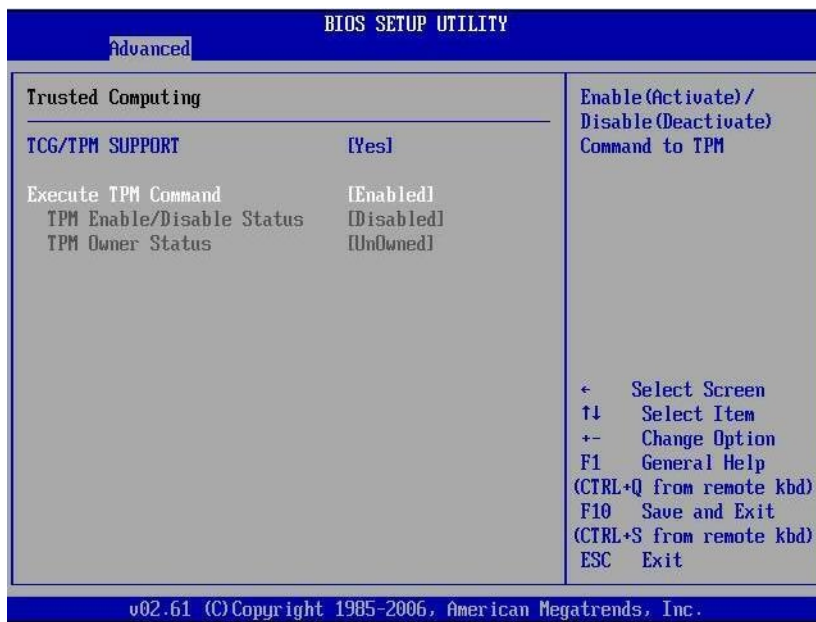

8. Press F10 to save the changes and exit the BIOS Setup Utility.

9. To verify that TPM support is configured, do the following:

- a. Reboot the server node.
- b. To enter the BIOS Setup Utility, press the F2 key while the system is performing the power-on self-test (POST).

When BIOS is started, the main BIOS Setup Utility top-level screen appears.

c. Select Advanced, then select Trusted Computing and press Enter.

The updated Trusted Computing screen appears.

Confirm that the TCG/TPM Support setting is set to `Yes` and the TPM Enabled/Disable Status is set to `Enabled`. See the following figure for an example:



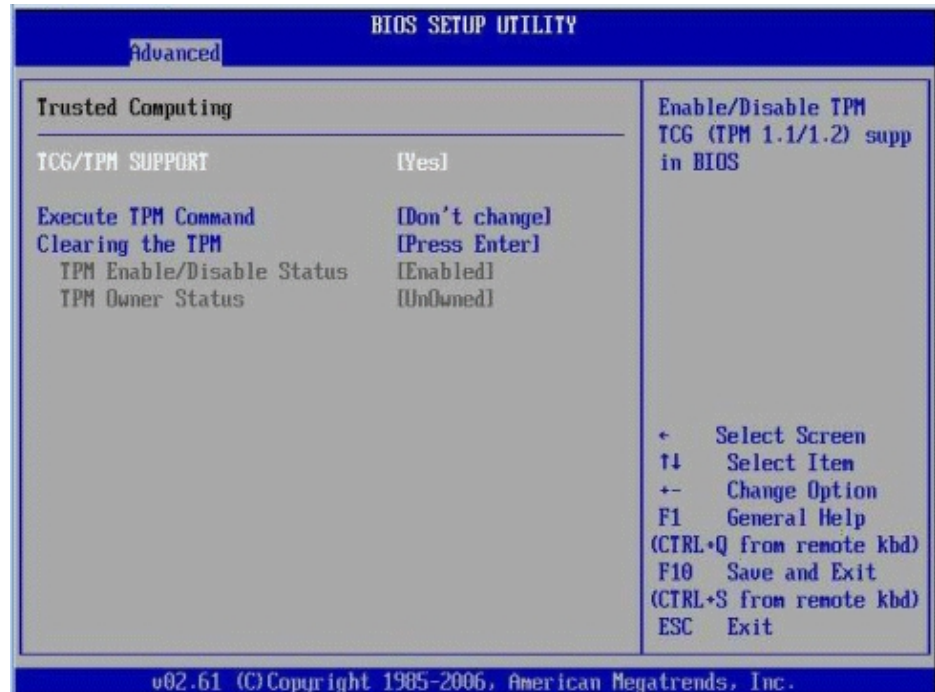

10. Press F10 to exit the BIOS Setup Utility.

This completes the TPM configuration.

## A.6.5 Configuring SP LAN Settings

Learn about configuring the service processor LAN settings for an Oracle Database Appliance Version 1 server node.

### Note:

Information in this appendix does NOT apply to Oracle Database Appliance X7 series, Oracle Database Appliance X6 series, or Oracle Database Appliance X3-2/X4-2/X5-2. Refer to the preceding chapters in this document for information on servicing those systems.

You can assign an IP address for the Oracle Database Appliance Version 1 server node SP from the BIOS Setup Utility on the IPMI LAN configuration menu. Alternatively, you can also specify the LAN settings for the SP using Oracle ILOM. For instructions for setting the IP address in Oracle ILOM, see *Oracle Integrated Lights Out Manager (Oracle ILOM) 3.0 Documentation Collection*.

- [Configure LAN Settings for SP](#) (page A-116)  
How to configure SP LAN settings in an Oracle Database Appliance Version 1 server node.

## A.6.5.1 Configure LAN Settings for SP

How to configure SP LAN settings in an Oracle Database Appliance Version 1 server node.

 **Note:**

Information in this appendix does NOT apply to Oracle Database Appliance X7 series, Oracle Database Appliance X6 series, or Oracle Database Appliance X3-2/X4-2/X5-2. Refer to the preceding chapters in this document for information on servicing those systems.

1. Access the BIOS Setup Utility menus.  
For instructions, see [Accessing the BIOS Setup Utility Menus](#) (page A-119).
2. In the BIOS Setup Utility menus, use the arrow keys (or Tab key) to navigate to the Advanced menu.
3. In the Advanced menu, select IPMI Configuration.
4. In the IPMI Configuration menu, select LAN Configuration.  
The LAN Configuration screen appears.
5. In the LAN Configuration screen, use the arrow keys to select and specify the appropriate LAN configuration settings. See the following figure for an example:

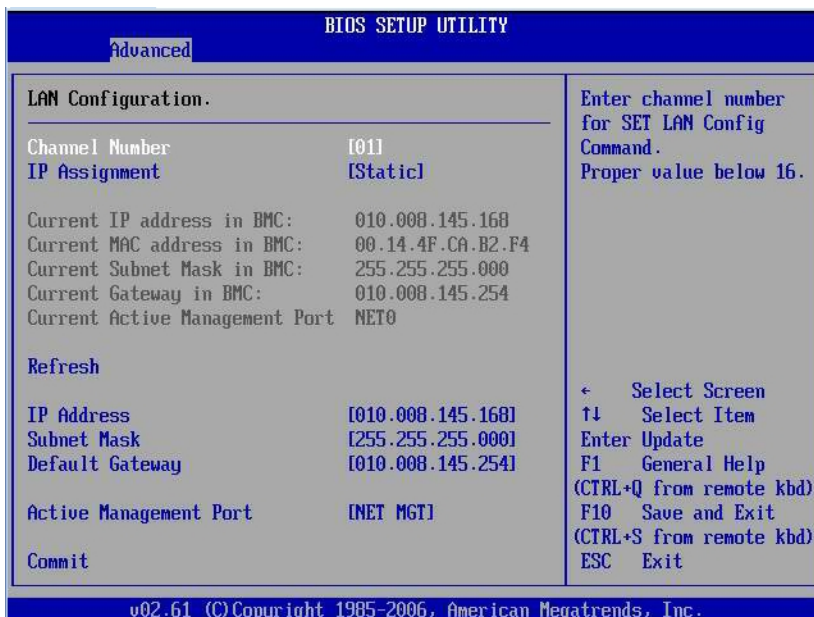

6. After making the necessary changes, select Commit and press Enter to apply the changes.
7. Press F10 to save the changes and exit BIOS.

## A.6.6 Configuring Option ROM Settings in BIOS

Learn about configuring option ROM for an Oracle Database Appliance Version 1 server node.

### Note:

Information in this appendix does NOT apply to Oracle Database Appliance X7 series, Oracle Database Appliance X6 series, or Oracle Database Appliance X3-2/X4-2/X5-2. Refer to the preceding chapters in this document for information on servicing those systems.

The Oracle Database Appliance Version 1 BIOS Option ROM space is 128 Kbytes. Of these 128 Kbytes, approximately 80 Kbytes are used by the VGA controller, the disk controller, and the network interface card. Approximately 48 Kbytes remain to be shared by the Option ROMs on all bootable PCI-Express plug-in cards.

- [Enable or Disable Option ROM Settings](#) (page A-117)  
How to configure option ROM settings in an Oracle Database Appliance Version 1 server node.

### A.6.6.1 Enable or Disable Option ROM Settings

How to configure option ROM settings in an Oracle Database Appliance Version 1 server node.

### Note:

Information in this appendix does NOT apply to Oracle Database Appliance X7 series, Oracle Database Appliance X6 series, or Oracle Database Appliance X3-2/X4-2/X5-2. Refer to the preceding chapters in this document for information on servicing those systems.

1. Access the BIOS Setup Utility menus.  
For instructions, see [Accessing the BIOS Setup Utility Menus](#) (page A-119).
2. In the BIOS Setup Utility menus, use the arrow keys (or Tab key) to navigate to the Boot menu.

The Boot menu appears. See the following figure for an example:



- In the Boot menu, highlight the Option ROM setting, and then press Enter.
- Check whether the settings in your screen output match what is shown above. If they do not match, proceed to the next step. If they match, proceed to Step 7 and exit BIOS.
- To change the settings, in the Boot menu listing the Option ROM settings, highlight the applicable Option ROM setting to modify, then press Enter.  
A dialog box appears listing the available settings.
- In the dialog box, do one of the following:
  - Select Enabled to enable the Option ROM setting.
  - Select Disabled to disable the Option ROM setting.
- Press F10 to save the changes and exit the BIOS Setup Utility.

## A.6.7 BIOS Setup Utility Hot Keys

Learn about BIOS Setup hot keys for an Oracle Database Appliance Version 1.

### Note:

Information in this appendix does NOT apply to Oracle Database Appliance X7 series, Oracle Database Appliance X6 series, or Oracle Database Appliance X3-2/X4-2/X5-2. Refer to the preceding chapters in this document for information on servicing those systems.

The following table provides a description of the Oracle Database Appliance Version 1 BIOS Setup Utility Oracle ILOM Remote Console keys and the directly attached keyboard keys, and the corresponding serial connection key combinations.

Oracle ILOM Remote Console Keys	Serial Connection Hot Key Combinations	Function
F1	Ctrl+Q (Press and hold the Control key and type Q)	Access the BIOS Setup Utility if there is an error during the boot process.

Oracle ILOM Remote Console Keys	Serial Connection Hot Key Combinations	Function
F2	Ctrl+E	Enter BIOS Setup Utility when the system has completed the power-on self-test (POST).
F7	Ctrl+D	Discard changes, but do not exit.
F8	Ctrl+P	Select the BBS Popup menu, which allows you to select a boot device.
F9	Ctrl+O	Load optimal BIOS defaults.
F10	Ctrl+S	Save changes and exit.
Note that F10 is not supported on the Oracle ILOM Remote Console; instead, use the arrow keys to navigate to the Exit menu and press Enter.		
F12	Ctrl+N	Boot the server node from the network (PXE boot).

## A.6.8 Accessing the BIOS Setup Utility Menus

Learn how to access BIOS Setup for an Oracle Database Appliance Version 1 server node.

### Note:

Information in this appendix does NOT apply to Oracle Database Appliance X7 series, Oracle Database Appliance X6 series, or Oracle Database Appliance X3-2/X4-2/X5-2. Refer to the preceding chapters in this document for information on servicing those systems.

You can access Oracle Database Appliance Version 1 BIOS Setup Utility screens from the following interfaces:

- Use a USB keyboard, mouse, and VGA monitor connected directly to the server node.
- Use a terminal (or terminal emulator connected to a computer) through the serial port on the back panel of the server node.
- Connect to the server node using the Oracle ILOM Remote Console.

The following procedure describes the steps for accessing the BIOS Setup Utility menus.

- [Access BIOS Setup Utility Menus](#) (page A-120)  
How to access BIOS Setup menus for an Oracle Database Appliance Version 1 server node.

## A.6.8.1 Access BIOS Setup Utility Menus

How to access BIOS Setup menus for an Oracle Database Appliance Version 1 server node.

### Note:

Information in this appendix does NOT apply to Oracle Database Appliance X7 series, Oracle Database Appliance X6 series, or Oracle Database Appliance X3-2/X4-2/X5-2. Refer to the preceding chapters in this document for information on servicing those systems.

1. Power-on or power-cycle the server node.
2. The system BIOS boot screen appears. See the following figure for an example:



```

American Megatrends
www.ami.com

Sun
ORACLE

AMIBIOS (C) 2009 American Megatrends, Inc.
BIOS Date: 06/19/09 05:37:42 Ver: 08.00.16
Oracle BIOS Revision: 12.01.03.07
Oracle X4370 M2 Server CPU Power (TDP Limit) = 95 Watts
Product Serial Number:1050CNW001
CPU : Intel (R) Xeon (R) CPU X5675 @ 3.07GHz
Speed : 3.06 GHz Count : 24

Press F2 to run Setup (CTRL+E on Serial Console)
Press F12 if you want to boot from the network (CTRL+N on Serial Console)
Press F8 for BBS POPUP (CTRL+P on Serial Console)
QPI Operational Speed at : 6.4GT/s
BMC Firmware Revision: 3.0.14.13.a r70764
Initializing USB Controllers .. Done.
98296MB OK

(C) American Megatrends, Inc.
66-3047-009999-00101111-061909-TYLSBURG-12010307-Y2KC 6B3B
  
```

3. To enter the BIOS Setup Utility, do the following:
  - a. Wait for the last line of the screen output to change to `Initializing USB Controllers..Done`. This will take several seconds.
  - b. When `Done` appears, press the F2 key immediately.

### Note:

If there is an error during the boot process, you can press F1 to access the BIOS Setup Utility.

The BIOS Setup Utility Main screen appears. See the following figure for an example:

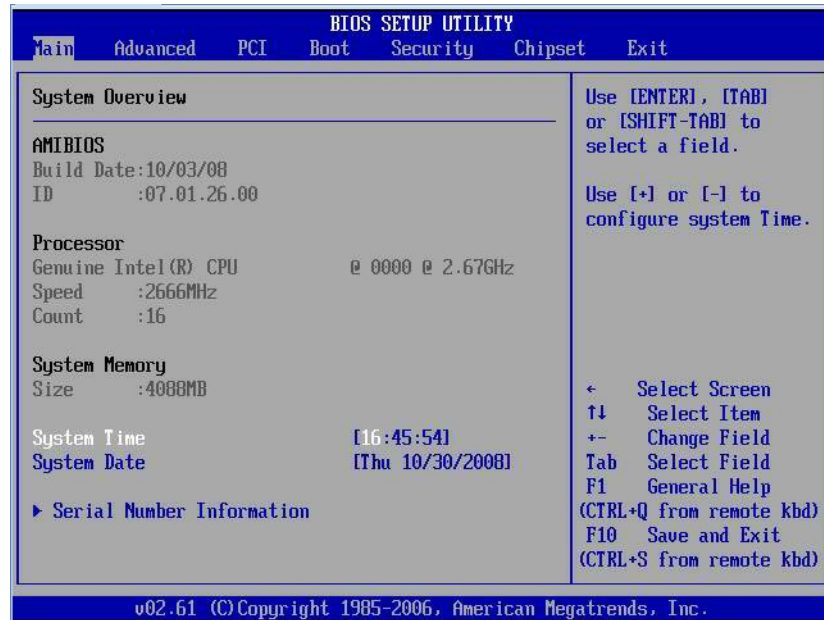

 **Note:**

If the BIOS Setup Utility dialog does not appear, you waited too long to press the F2 key. When `DONE` appears on the screen, you must press the F2 key immediately. Try again.

4. Use the left and right arrow keys to select the different menu options.
5. As you select each menu option, the top-level screen for that menu option appears.
6. To select an option on a top-level screen, use the up and down arrow keys to scroll up and down the options presented.

Only options that can be modified are highlighted when you press the up and down arrow keys.

- If a field can be modified, as you select the option, user instructions for modifying the option appear in the right column of the screen.
- If a field is a link to a sub-screen, instructions to press the Enter key to access the sub-screen appear in the right column.

7. Modify the setup field and press the Esc key to save the changes and exit the screen.

Some screens present a confirmation dialog box that enables unwanted changes to be retracted.

8. On sub-screens that only provide configuration information and cannot be modified, press the Esc key to exit the screen.
9. To continue modifying other setup parameters, repeat Step 4 through Step 8. Otherwise, go to Step 10.
10. Press and release the right arrow key until the Exit menu screen appears.



11. Follow the instructions on the Exit menu screen to save or discard your changes and exit the BIOS Setup Utility.

## A.6.9 BIOS Setup Utility Screens

Learn about BIOS Setup utility screens for an Oracle Database Appliance Version 1 server node.

### Note:

Information in this appendix does NOT apply to Oracle Database Appliance X7 series, Oracle Database Appliance X6 series, or Oracle Database Appliance X3-2/X4-2/X5-2. Refer to the preceding chapters in this document for information on servicing those systems.

The BIOS utility includes seven top-level screens, many of which include sub-screens. Arrow keys provide navigation, and the options or fields that you can configure appear in color. Online instructions provide additional information.

### Note:

The screens shown are examples. The version numbers and the screen items and selections shown are subject to change over the life of the product.

- [BIOS Setup Utility Screen Overview](#) (page A-123)  
Learn about BIOS Setup utility screens for an Oracle Database Appliance Version 1 server node.
- [BIOS Main Menu Screen](#) (page A-124)  
Learn about BIOS Setup main screen for an Oracle Database Appliance Version 1 server module.
- [BIOS Advanced Menu Screen](#) (page A-125)  
Learn about BIOS Setup Advanced screen for an Oracle Database Appliance Version 1 server module.
- [BIOS PCI Menu Screen](#) (page A-126)  
Learn about BIOS Setup PCI screen for an Oracle Database Appliance Version 1 server module.
- [BIOS Boot Menu Screen](#) (page A-127)  
Learn about BIOS Setup Boot screen for an Oracle Database Appliance Version 1 server module.
- [BIOS Security Menu Screen](#) (page A-128)  
Learn about BIOS Setup Security screen for an Oracle Database Appliance Version 1 server module.
- [BIOS Chipset Menu Screen](#) (page A-128)  
Learn about BIOS Setup Chipset screen for an Oracle Database Appliance Version 1 server module.



- [BIOS Exit Menu Screen](#) (page A-129)  
Learn about BIOS Exit utility screens for an Oracle Database Appliance Version 1 server node.

### A.6.9.1 BIOS Setup Utility Screen Overview

Learn about BIOS Setup utility screens for an Oracle Database Appliance Version 1 server node.

 **Note:**

Information in this appendix does NOT apply to Oracle Database Appliance X7 series, Oracle Database Appliance X6 series, or Oracle Database Appliance X3-2/X4-2/X5-2. Refer to the preceding chapters in this document for information on servicing those systems.

The following table contains summary descriptions of the Oracle Database Appliance Version 1 top-level BIOS setup screens.

Screen	Description	See This Section
Main	General product information, including BIOS type, processor, memory, and time/date.	<a href="#">BIOS Main Menu Screen</a> (page A-124)
Advanced	Configuration information for the CPU, memory, IDE, Super IO, trusted computing, USB, PCI, MPS and other information.	<a href="#">BIOS Advanced Menu Screen</a> (page A-125)
PCI	Configure the system to clear NVRAM during system boot.	<a href="#">BIOS PCI Menu Screen</a> (page A-126)
Boot	Configure the boot device priority (storage drives and boot disk drives).	<a href="#">BIOS Boot Menu Screen</a> (page A-127)
Security	Set or change the user and supervisor passwords.	<a href="#">BIOS Security Menu Screen</a> (page A-128)
Chipset	View the configuration of system chipset.	<a href="#">BIOS Chipset Menu Screen</a> (page A-128)
Exit	Save changes and exit, discard changes and exit, discard changes, or load optimal or fail-safe defaults.	<a href="#">BIOS Exit Menu Screen</a> (page A-129)

The following figure shows a map of the BIOS Setup screens.

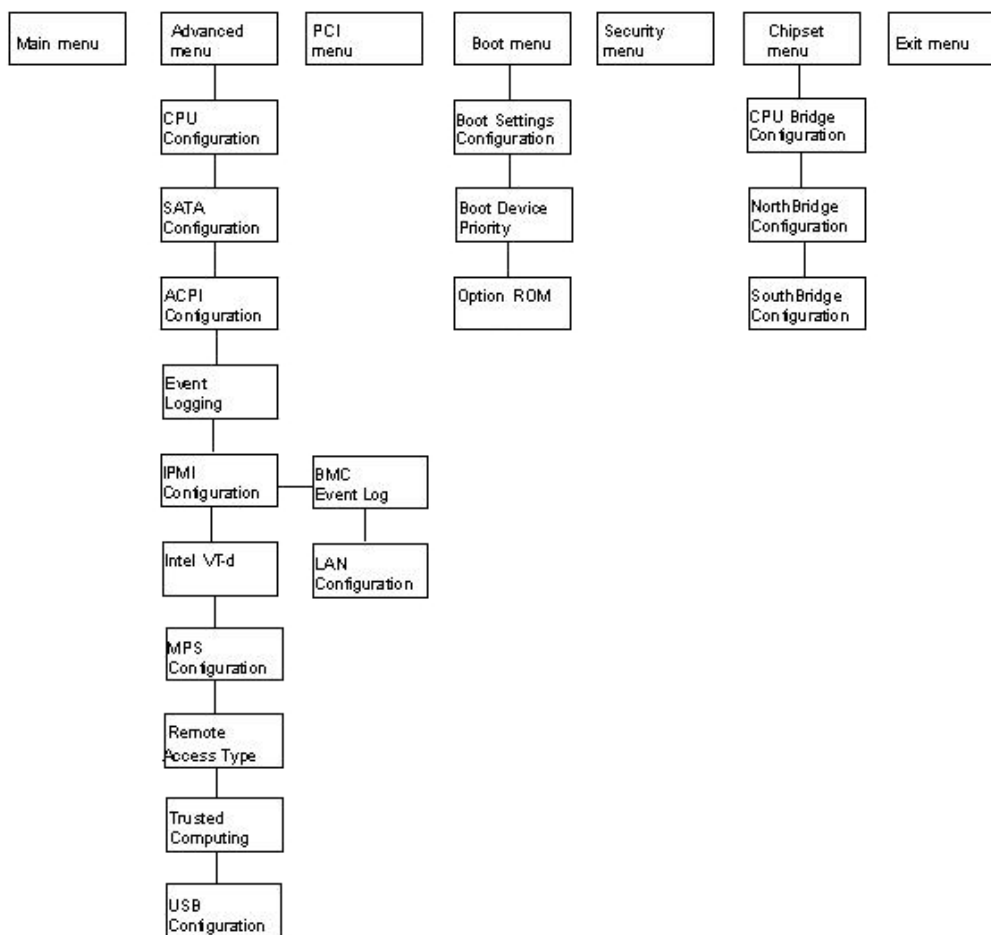

### A.6.9.2 BIOS Main Menu Screen

Learn about BIOS Setup main screen for an Oracle Database Appliance Version 1 server module.



**Note:**

Information in this appendix does NOT apply to Oracle Database Appliance X7 series, Oracle Database Appliance X6 series, or Oracle Database Appliance X3-2/X4-2/X5-2. Refer to the preceding chapters in this document for information on servicing those systems.

The Oracle Database Appliance Version 1 BIOS Main screen provides general product information, including BIOS, processor, system memory, and system time/date. See the following figure for an example:

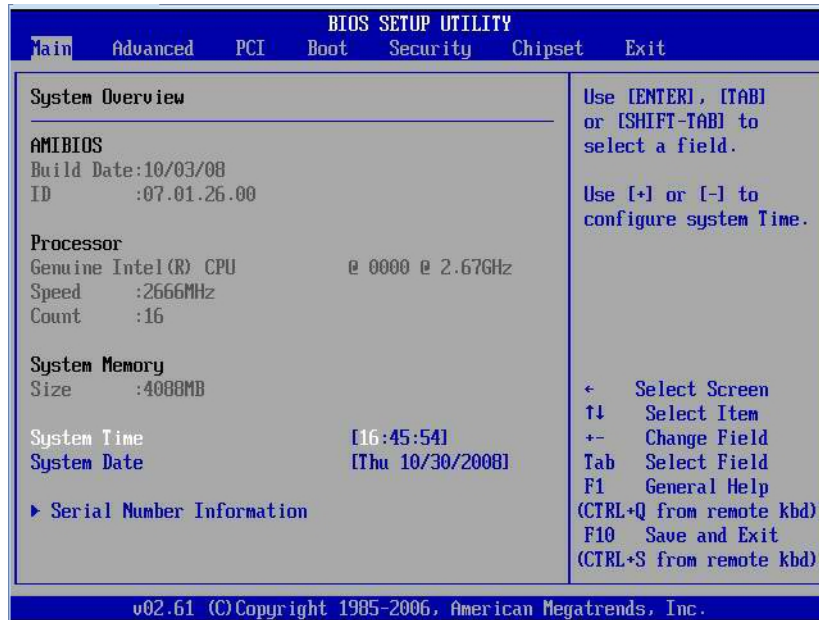

### A.6.9.3 BIOS Advanced Menu Screen

Learn about BIOS Setup Advanced screen for an Oracle Database Appliance Version 1 server module.

 **Note:**

Information in this appendix does NOT apply to Oracle Database Appliance X7 series, Oracle Database Appliance X6 series, or Oracle Database Appliance X3-2/X4-2/X5-2. Refer to the preceding chapters in this document for information on servicing those systems.

The Oracle Database Appliance Version 1 BIOS Advanced screen provides detailed configuration information for the CPU, memory, IDE, Super IO, trusted computing, USB, PCI, MPS and other system information. See the following figure for an example:



#### A.6.9.4 BIOS PCI Menu Screen

Learn about BIOS Setup PCI screen for an Oracle Database Appliance Version 1 server module.



**Note:**

Information in this appendix does NOT apply to Oracle Database Appliance X7 series, Oracle Database Appliance X6 series, or Oracle Database Appliance X3-2/X4-2/X5-2. Refer to the preceding chapters in this document for information on servicing those systems.

The Oracle Database Appliance Version 1 BIOS PCI screen enables you to configure the server node to clear NVRAM during system boot. See the following figure for an example:



### A.6.9.5 BIOS Boot Menu Screen

Learn about BIOS Setup Boot screen for an Oracle Database Appliance Version 1 server module.

 **Note:**

Information in this appendix does NOT apply to Oracle Database Appliance X7 series, Oracle Database Appliance X6 series, or Oracle Database Appliance X3-2/X4-2/X5-2. Refer to the preceding chapters in this document for information on servicing those systems.

The Oracle Database Appliance Version 1 BIOS Boot screen enables you to configure the boot device priority (storage drives and the DVD-ROM drive). See the following figure for an example:



## A.6.9.6 BIOS Security Menu Screen

Learn about BIOS Setup Security screen for an Oracle Database Appliance Version 1 server module.

### Note:

Information in this appendix does NOT apply to Oracle Database Appliance X7 series, Oracle Database Appliance X6 series, or Oracle Database Appliance X3-2/X4-2/X5-2. Refer to the preceding chapters in this document for information on servicing those systems.

The Oracle Database Appliance Version 1 BIOS Security screen enables you to set or change the supervisor and user passwords. See the following figure for an example:

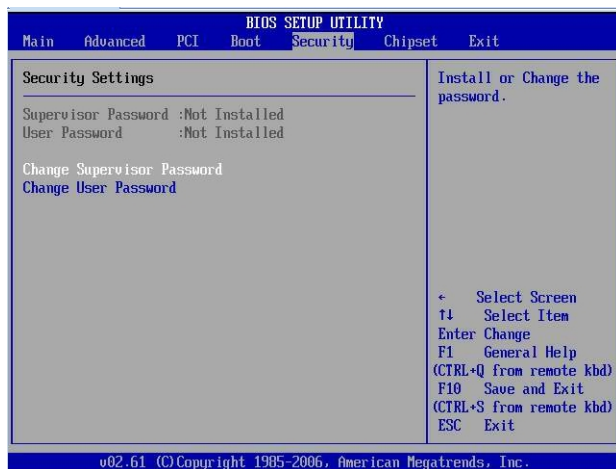

The default state is for the passwords to be unconfigured (not required).

- If you configure a supervisor password, users must enter it to access BIOS setup.
- If you configure a user password, users must enter it before booting an OS.

## A.6.9.7 BIOS Chipset Menu Screen

Learn about BIOS Setup Chipset screen for an Oracle Database Appliance Version 1 server module.

### Note:

Information in this appendix does NOT apply to Oracle Database Appliance X7 series, Oracle Database Appliance X6 series, or Oracle Database Appliance X3-2/X4-2/X5-2. Refer to the preceding chapters in this document for information on servicing those systems.

The Oracle Database Appliance Version 1 BIOS Chipset screen enables you to set the chipset parameters. See the following figure for an example:



### A.6.9.8 BIOS Exit Menu Screen

Learn about BIOS Exit utility screens for an Oracle Database Appliance Version 1 server node.

 **Note:**

Information in this appendix does NOT apply to Oracle Database Appliance X7 series, Oracle Database Appliance X6 series, or Oracle Database Appliance X3-2/X4-2/X5-2. Refer to the preceding chapters in this document for information on servicing those systems.

The Oracle Database Appliance Version 1 BIOS Exit options enable you to save changes and exit, discard changes and exit, discard changes, or load optimal defaults. See the following figure for an example:

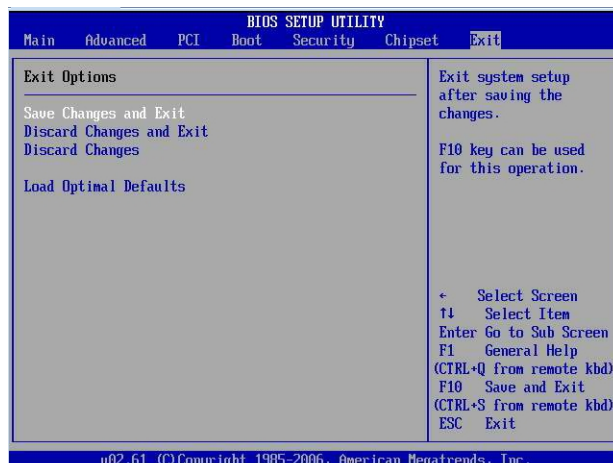

- [Exit From the BIOS Setup Utility](#) (page A-130)  
How to access BIOS Exit menu for an Oracle Database Appliance Version 1 server node.

### A.6.9.8.1 Exit From the BIOS Setup Utility

How to access BIOS Exit menu for an Oracle Database Appliance Version 1 server node.

 **Note:**

Information in this appendix does NOT apply to Oracle Database Appliance X7 series, Oracle Database Appliance X6 series, or Oracle Database Appliance X3-2/X4-2/X5-2. Refer to the preceding chapters in this document for information on servicing those systems.

1. Use the up and down arrow keys to scroll up and down the BIOS Exit options.
2. Press Enter to select the option.

A confirmation dialog box appears that enables you to save the changes and exit the Setup Utility or cancel the exit option.

 **Note:**

The confirmation dialog box is only shown below for the Save Changes and Exit option screen. The other exit confirmation screens work in a similar way.

**Figure A-2 BIOS Setup Utility Save and Exit Screen**





# Index

## A

---

- air duct
  - installing
    - Oracle Database Appliance Version 1, [A-54](#)
  - removing
    - Oracle Database Appliance Version 1, [A-53](#)
- antistatic wrist strap
  - described
    - Oracle Database Appliance Version 1, [A-8](#)
    - Oracle Database Appliance X3-2/X4-2/X5-2, [2-3](#)
    - Oracle Database Appliance X6-2 series, [2-2](#)
    - Oracle Database Appliance X7-2 series, [2-1](#)

## B

---

- battery
  - installing
    - Oracle Database Appliance Version 1, [4-5](#), [A-51](#)
    - Oracle Database Appliance X3-2/X4-2/X5-2, [4-3](#)
    - Oracle Database Appliance X6-2 series, [4-2](#)
    - Oracle Database Appliance X7-2 series, [4-1](#)
  - removing
    - Oracle Database Appliance Version 1, [4-5](#), [A-50](#)
    - Oracle Database Appliance X3-2/X4-2/X5-2, [4-3](#)
    - Oracle Database Appliance X6-2 series, [4-2](#)
    - Oracle Database Appliance X7-2 series, [4-1](#)
- BIOS
  - accessing the setup utility
    - Oracle Database Appliance Version 1, [A-120](#)

## BIOS (*continued*)

- accessing the setup utility (*continued*)
  - Oracle Database Appliance X3-2/X4-2/X5-2, [8-5](#)
  - Oracle Database Appliance X6-2 series, [8-3](#)
  - Oracle Database Appliance X7-2 series, [8-2](#)
- advanced menu options
  - Oracle Database Appliance X3-2/X4-2/X5-2, [8-5](#)
  - Oracle Database Appliance X6-2 series, [8-4](#)
  - Oracle Database Appliance X7-2 series, [8-2](#)
- advanced screen
  - Oracle Database Appliance Version 1, [A-125](#)
- boot menu options
  - Oracle Database Appliance X3-2/X4-2/X5-2, [8-5](#)
  - Oracle Database Appliance X6-2 series, [8-4](#)
  - Oracle Database Appliance X7-2 series, [8-2](#)
- boot screen
  - Oracle Database Appliance Version 1, [A-127](#)
- chipset screen
  - Oracle Database Appliance Version 1, [A-128](#)
- common tasks
  - Oracle Database Appliance X3-2/X4-2/X5-2, [8-5](#)
  - Oracle Database Appliance X6-2 series, [8-3](#)
  - Oracle Database Appliance X7-2 series, [8-2](#)
- configuring Trusted Platform Module (TPM)
  - Oracle Database Appliance Version 1, [A-111](#)
- exit screens
  - Oracle Database Appliance Version 1, [A-129](#)
- exiting the setup utility

## BIOS (continued)

- exiting the setup utility (continued)
    - Oracle Database Appliance Version 1, [A-130](#)
  - I/O menu options
    - Oracle Database Appliance X3-2/X4-2/X5-2, [8-5](#)
    - Oracle Database Appliance X6-2 series, [8-4](#)
    - Oracle Database Appliance X7-2 series, [8-2](#)
  - LAN settings
    - Oracle Database Appliance Version 1, [A-116](#)
  - legacy and UEFI modes
    - Oracle Database Appliance X3-2/X4-2/X5-2, [8-5](#)
    - Oracle Database Appliance X6-2 series, [8-3](#)
    - Oracle Database Appliance X7-2 series, [8-2](#)
  - main menu options
    - Oracle Database Appliance X3-2/X4-2/X5-2, [8-5](#)
    - Oracle Database Appliance X6-2 series, [8-4](#)
    - Oracle Database Appliance X7-2 series, [8-2](#)
  - main screen
    - Oracle Database Appliance Version 1, [A-124](#)
  - managing configurations
    - Oracle Database Appliance X3-2/X4-2/X5-2, [8-5](#)
    - Oracle Database Appliance X6-2 series, [8-3](#)
    - Oracle Database Appliance X7-2 series, [8-2](#)
  - memory testing
    - Oracle Database Appliance Version 1, [A-106](#)
    - Oracle Database Appliance X3-2/X4-2/X5-2, [7-1](#)
    - Oracle Database Appliance X6-2 series, [7-1](#)
    - Oracle Database Appliance X7-2 series, [7-1](#)
  - option ROM settings
    - Oracle Database Appliance Version 1, [A-117](#)
  - overview, [8-1](#)
    - Oracle Database Appliance Version 1, [8-6](#)
    - Oracle Database Appliance X3-2/X4-2/X5-2, [8-4](#)

## BIOS (continued)

- overview (continued)
    - Oracle Database Appliance X6-2 series, [8-3](#)
    - Oracle Database Appliance X7-2 series, [8-1](#)
  - PCI screen
    - Oracle Database Appliance Version 1, [A-126](#)
  - POST errors
    - Oracle Database Appliance Version 1, [A-104](#)
    - Oracle Database Appliance X3-2/X4-2/X5-2, [7-1](#)
    - Oracle Database Appliance X6-2 series, [7-1](#)
    - Oracle Database Appliance X7-2 series, [7-1](#)
  - POST events
    - Oracle Database Appliance Version 1, [A-102](#)
  - resetting password
    - Oracle Database Appliance Version 1, [A-108](#)
  - save and exit options
    - Oracle Database Appliance X3-2/X4-2/X5-2, [8-5](#)
    - Oracle Database Appliance X6-2 series, [8-4](#)
    - Oracle Database Appliance X7-2 series, [8-2](#)
  - security screen
    - Oracle Database Appliance Version 1, [A-128](#)
  - setup screens overview
    - Oracle Database Appliance Version 1, [A-123](#)
  - setup screens summary
    - Oracle Database Appliance Version 1, [A-122](#)
    - Oracle Database Appliance X3-2/X4-2/X5-2, [8-5](#)
    - Oracle Database Appliance X6-2 series, [8-4](#)
    - Oracle Database Appliance X7-2 series, [8-2](#)
  - setup utility hot keys
    - Oracle Database Appliance Version 1, [A-118](#)
    - Oracle Database Appliance X3-2/X4-2/X5-2, [8-5](#)
    - Oracle Database Appliance X6-2 series, [8-3](#)
    - Oracle Database Appliance X7-2 series, [8-2](#)

BIOS (*continued*)

## UEFI driver control options

- Oracle Database Appliance X3-2/X4-2/  
X5-2, [8-5](#)
- Oracle Database Appliance X6-2 series,  
[8-4](#)
- Oracle Database Appliance X7-2 series,  
[8-2](#)

## using for resource allocation

- Oracle Database Appliance X3-2/X4-2/  
X5-2, [8-5](#)
- Oracle Database Appliance X6-2 series,  
[8-3](#)
- Oracle Database Appliance X7-2 series,  
[8-2](#)

## BIOS Setup Utility

## accessing

- Oracle Database Appliance Version 1,  
[A-119](#)
- Oracle Database Appliance X3-2/X4-2/  
X5-2, [8-5](#)
- Oracle Database Appliance X6-2 series,  
[8-3](#)
- Oracle Database Appliance X7-2 series,  
[8-2](#)

## boot disk backplane cables

## installing

- Oracle Database Appliance Version 1,  
[A-89](#)
- Oracle Database Appliance X3-2/X4-2/  
X5-2, [5-10](#)
- Oracle Database Appliance X6-2 series,  
[5-2](#)
- Oracle Database Appliance X7-2 series,  
[5-1](#)

## removing

- Oracle Database Appliance Version 1,  
[A-88](#)
- Oracle Database Appliance X3-2/X4-2/  
X5-2, [5-10](#)
- Oracle Database Appliance X6-2 series,  
[5-2](#)
- Oracle Database Appliance X7-2 series,  
[5-1](#)

## boot drive

## installing in server node

- Oracle Database Appliance Version 1,  
[A-21](#)

## removing from server node

- Oracle Database Appliance Version 1,  
[A-20](#)

## C

## cables

cables (*continued*)

## reconnecting power and data cables after servicing

- Oracle Database Appliance Version 1,  
[A-99](#)
- Oracle Database Appliance X3-2/X4-2/  
X5-2, [6-3](#)
- Oracle Database Appliance X6-2 series,  
[6-2](#)
- Oracle Database Appliance X7-2 series,  
[6-1](#)

## servicing

- Oracle Database Appliance Version 1,  
[A-78](#)

## chassis interlock switch

## disconnecting

- Oracle Database Appliance Version 1,  
[A-64](#)

## reconnecting

- Oracle Database Appliance Version 1,  
[A-66](#)

## CLR CMOS button

## location of

- Oracle Database Appliance Version 1,  
[A-108](#), [A-111](#)

## CMOS NVRAM

## clearing

- Oracle Database Appliance Version 1,  
[A-107](#)

## cold service components

## CRUs

- Oracle Database Appliance Version 1,  
[4-5](#), [A-29](#)
- Oracle Database Appliance X3-2/X4-2/  
X5-2, [4-3](#)
- Oracle Database Appliance X6-2 series,  
[4-2](#)
- Oracle Database Appliance X7-2 series,  
[4-1](#)

## FRUs

- Oracle Database Appliance X3-2/X4-2/  
X5-2, [5-10](#)
- Oracle Database Appliance X6-2 series,  
[5-2](#)
- Oracle Database Appliance X7-2 series,  
[5-1](#)

## CPUs

## clearing faults

- Oracle Database Appliance Version 1,  
[A-59](#)
- Oracle Database Appliance X3-2/X4-2/  
X5-2, X6-2 series and X7-2  
series, [5-11](#)

## installing

- CPUs (*continued*)
  - installing (*continued*)
    - Oracle Database Appliance Version 1, [A-59](#)
    - Oracle Database Appliance X3-2/X4-2/X5-2, [5-10](#)
    - Oracle Database Appliance X6-2 series, [5-2](#)
    - Oracle Database Appliance X7-2 series, [5-1](#)
  - population rules
    - Oracle Database Appliance Version 1, [A-31](#)
    - Oracle Database Appliance X3-2/X4-2/X5-2, [5-10](#)
    - Oracle Database Appliance X6-2 series, [5-2](#)
    - Oracle Database Appliance X7-2 series, [5-1](#)
  - removing
    - Oracle Database Appliance Version 1, [A-56](#)
    - Oracle Database Appliance X3-2/X4-2/X5-2, [5-10](#)
    - Oracle Database Appliance X6-2 series, [5-2](#)
    - Oracle Database Appliance X7-2 series, [5-1](#)
  - servicing
    - Oracle Database Appliance Version 1, [A-55](#)
    - Oracle Database Appliance X3-2/X4-2/X5-2, [5-10](#)
    - Oracle Database Appliance X6-2 series, [5-2](#)
    - Oracle Database Appliance X7-2 series, [5-1](#)
- CRUs
  - component locations
    - Oracle Database Appliance Version 1, [4-5](#), [A-29](#)
    - Oracle Database Appliance X3-2/X4-2/X5-2, [4-3](#)
    - Oracle Database Appliance X6-2 series, [4-2](#)
    - Oracle Database Appliance X7-2 series, [4-1](#)
  - removal that does not require system power off, [3-1](#)
  - servicing non-hotplug components, [4-1](#)
- D

---

- date and time
  - resetting after battery replacement
- date and time (*continued*)
  - resetting after battery replacement (*continued*)
    - Oracle Database Appliance Version 1, [4-5](#)
    - Oracle Database Appliance X3-2/X4-2/X5-2, [4-3](#)
    - Oracle Database Appliance X6-2 series, [4-2](#)
    - Oracle Database Appliance X7-2 series, [4-1](#)
- diagnostic tools
  - summary of, [7-1](#)
- diagnostics
  - available tools, [7-1](#)
- DIMMs
  - clearing faults
    - Oracle Database Appliance Version 1, [A-35](#)
    - Oracle Database Appliance X3-2/X4-2/X5-2, X6-2 series and X7-2 series, [5-11](#)
  - ECC and parity errors
    - Oracle Database Appliance Version 1, [A-37](#)
  - installing
    - Oracle Database Appliance Version 1, [4-5](#), [A-35](#)
    - Oracle Database Appliance X3-2/X4-2/X5-2, [4-3](#)
    - Oracle Database Appliance X6-2 series, [4-2](#)
    - Oracle Database Appliance X7-2 series, [4-1](#)
  - population rules
    - Oracle Database Appliance Version 1, [4-5](#), [A-31](#)
    - Oracle Database Appliance X3-2/X4-2/X5-2, [4-3](#)
    - Oracle Database Appliance X6-2 series, [4-2](#)
    - Oracle Database Appliance X7-2 series, [4-1](#)
  - removing
    - Oracle Database Appliance Version 1, [4-5](#), [A-32](#)
    - Oracle Database Appliance X3-2/X4-2/X5-2, [4-3](#)
    - Oracle Database Appliance X6-2 series, [4-2](#)
    - Oracle Database Appliance X7-2 series, [4-1](#)
  - servicing
    - Oracle Database Appliance Version 1, [4-5](#), [A-30](#)

DIMMs (*continued*)  
 servicing (*continued*)  
 Oracle Database Appliance X3-2/X4-2/  
 X5-2, [4-3](#)  
 Oracle Database Appliance X6-2 series,  
[4-2](#)  
 Oracle Database Appliance X7-2 series,  
[4-1](#)

disk backplane  
 installing  
 Oracle Database Appliance Version 1,  
[A-62](#)  
 removing  
 Oracle Database Appliance Version 1,  
[A-61](#)  
 servicing boot disk backplane  
 Oracle Database Appliance Version 1,  
[A-61](#)  
 servicing disk backplane  
 Oracle Database Appliance X3-2/X4-2/  
 X5-2, [5-10](#)  
 Oracle Database Appliance X6-2 series,  
[5-2](#)  
 Oracle Database Appliance X7-2 series,  
[5-1](#)

disk drives  
 adding NVMe storage to the server  
 Oracle Database Appliance X6-2 series,  
[3-10](#)  
 Oracle Database Appliance X7-2 series,  
[3-5](#)  
 adding optional drives to the storage shelf  
 Oracle Database Appliance X6-2-HA,  
[3-19](#)  
 Oracle Database Appliance X7-2-HA,  
[3-15](#)  
 location in system  
 Oracle Database Appliance Version 1,  
[A-15](#)  
 replacing boot drives in server node  
 Oracle Database Appliance Version 1,  
[A-15](#)  
 replacing in server node  
 Oracle Database Appliance Version 1,  
[3-31](#)  
 Oracle Database Appliance X3-2/X4-2/  
 X5-2, [3-12](#)  
 Oracle Database Appliance X6-2 series,  
[3-6](#)  
 Oracle Database Appliance X7-2 series,  
[3-1](#)  
 replacing in storage shelf  
 Oracle Database Appliance X3-2/X4-2/  
 X5-2 and X6-2-HA, [3-21](#)  
 replacing NVMe storage

disk drives (*continued*)  
 replacing NVMe storage (*continued*)  
 Oracle Database Appliance X6-2 series,  
[3-8](#)  
 Oracle Database Appliance X7-2 series,  
[3-3](#)

disk midplane module  
 installing  
 Oracle Database Appliance Version 1,  
[A-71](#)  
 removing  
 Oracle Database Appliance Version 1,  
[A-68](#)  
 servicing  
 Oracle Database Appliance Version 1,  
[A-67](#)

disk midplane module HDD cable  
 installing  
 Oracle Database Appliance Version 1,  
[A-74](#)  
 removing  
 Oracle Database Appliance Version 1,  
[A-73](#)  
 servicing  
 Oracle Database Appliance Version 1,  
[A-72](#)

## E

---

electrostatic discharge (ESD)  
 precautions  
 Oracle Database Appliance Version 1,  
[A-8](#)  
 Oracle Database Appliance X3-2/X4-2/  
 X5-2, [2-3](#)  
 Oracle Database Appliance X6-2 series,  
[2-2](#)  
 Oracle Database Appliance X7-2 series,  
[2-1](#)

emergency shutdown  
 server node  
 Oracle Database Appliance Version 1,  
[A-5](#)  
 Oracle Database Appliance X3-2/X4-2/  
 X5-2, [2-3](#)  
 Oracle Database Appliance X6-2 series,  
[2-2](#)  
 Oracle Database Appliance X7-2 series,  
[2-1](#)

Ethernet ports  
 LEDs  
 Oracle Database Appliance Version 1,  
[1-51](#)  
 Oracle Database Appliance X3-2/X4-2,  
[1-39](#)

Ethernet ports (*continued*)LEDs (*continued*)Oracle Database Appliance X5-2, [1-32](#)Oracle Database Appliance X6-2-HA,  
[1-24](#)Oracle Database Appliance X6-2L, [1-20](#)Oracle Database Appliance X6-2S/  
X6-2M, [1-16](#)Oracle Database Appliance X7-2-HA, [1-9](#)Oracle Database Appliance X7-2S/  
X7-2M, [1-4](#)

## naming and boot priority

Oracle Database Appliance Version 1,  
[A-109](#)Oracle Database Appliance X3-2/X4-2/  
X5-2, [8-5](#)Oracle Database Appliance X6-2 series,  
[8-4](#)Oracle Database Appliance X7-2 series,  
[8-2](#)

## F

## fan cables

## installing

Oracle Database Appliance Version 1,  
[A-80](#)

## removing

Oracle Database Appliance Version 1,  
[A-79](#)

## servicing

Oracle Database Appliance Version 1,  
[A-79](#)

## fans

## detecting faults using LEDs

Oracle Database Appliance Version 1,  
[A-23](#)Oracle Database Appliance X3-2/X4-2,  
[1-36](#)Oracle Database Appliance X5-2, [1-30](#)Oracle Database Appliance X6-2-HA,  
[1-22](#)Oracle Database Appliance X6-2L, [1-18](#)Oracle Database Appliance X6-2S/  
X6-2M, [1-14](#)Oracle Database Appliance X7-2-HA, [1-6](#)Oracle Database Appliance X7-2S/  
X7-2M, [1-2](#)

## installing

Oracle Database Appliance Version 1,  
[A-24](#)

## removing

Oracle Database Appliance Version 1,  
[A-23](#)

## replacing in server node

fans (*continued*)replacing in server node (*continued*)Oracle Database Appliance Version 1,  
[3-31](#)Oracle Database Appliance X3-2/X4-2/  
X5-2, [3-12](#)Oracle Database Appliance X6-2 series,  
[3-6](#)Oracle Database Appliance X7-2 series,  
[3-1](#)

## faults

## clearing CPU faults

Oracle Database Appliance Version 1,  
[A-59](#)Oracle Database Appliance X3-2/X4-2/  
X5-2, X6-2 series and X7-2  
series, [5-11](#)

## clearing DIMM faults

Oracle Database Appliance Version 1,  
[A-35](#)Oracle Database Appliance X3-2/X4-2/  
X5-2, X6-2 series and X7-2  
series, [5-11](#)

## clearing PCIe card faults

Oracle Database Appliance Version 1,  
[A-44](#)Oracle Database Appliance X3-2/X4-2/  
X5-2, X6-2 series and X7-2  
series, [5-11](#)

## clearing PCIe riser faults

Oracle Database Appliance Version 1,  
[A-40](#)Oracle Database Appliance X3-2/X4-2/  
X5-2, X6-2 series and X7-2  
series, [5-11](#)

## clearing the primary HBA card faults

Oracle Database Appliance Version 1,  
[A-47](#)Oracle Database Appliance X3-2/X4-2/  
X5-2, X6-2 series and X7-2  
series, [5-11](#)

## managing

Oracle Database Appliance X3-2/X4-2/  
X5-2, X6-2 series and X7-2  
series, [5-11](#)

## front indicator panel

## installing

Oracle Database Appliance Version 1,  
[A-77](#)

## removing

Oracle Database Appliance Version 1,  
[A-75](#)

## servicing

Oracle Database Appliance Version 1,  
[A-74](#)

front indicator panels  
 servicing  
   Oracle Database Appliance X3-2/X4-2/  
   X5-2, [5-10](#)  
   Oracle Database Appliance X6-2 series,  
   [5-2](#)  
   Oracle Database Appliance X7-2 series,  
   [5-1](#)

FRUs  
 cold service components  
   Oracle Database Appliance Version 1,  
   [5-12](#)

component locations  
   Oracle Database Appliance Version 1,  
   [A-2](#)  
   Oracle Database Appliance X3-2/X4-2/  
   X5-2, [5-10](#)  
   Oracle Database Appliance X6-2 series,  
   [5-2](#)  
   Oracle Database Appliance X7-2 series,  
   [5-1](#)

managing component faults, [5-11](#)  
 servicing non-hotplug FRU components, [5-1](#)

## G

---

graceful shutdown  
 server node  
   Oracle Database Appliance Version 1,  
   [A-5](#)  
   Oracle Database Appliance X3-2/X4-2/  
   X5-2, [2-3](#)  
   Oracle Database Appliance X6-2 series,  
   [2-2](#)  
   Oracle Database Appliance X7-2 series,  
   [2-1](#)

## H

---

HBA  
 installing  
   Oracle Database Appliance X3-2/X4-2/  
   X5-2, [5-10](#)  
   Oracle Database Appliance X6-2 series,  
   [5-2](#)  
   Oracle Database Appliance X7-2 series,  
   [5-1](#)

installing primary HBA cables  
   Oracle Database Appliance Version 1,  
   [A-83](#)

installing secondary HBA cables  
   Oracle Database Appliance Version 1,  
   [A-84](#)

installing the primary HBA card

HBA (*continued*)  
 installing the primary HBA card (*continued*)  
   Oracle Database Appliance Version 1,  
   [A-47](#)

primary and secondary cards  
   Oracle Database Appliance Version 1,  
   [A-42](#)

removing  
   Oracle Database Appliance X3-2/X4-2/  
   X5-2, [5-10](#)  
   Oracle Database Appliance X6-2 series,  
   [5-2](#)  
   Oracle Database Appliance X7-2 series,  
   [5-1](#)

removing primary HBA cables  
   Oracle Database Appliance Version 1,  
   [A-82](#)

removing secondary HBA cables  
   Oracle Database Appliance Version 1,  
   [A-83](#)

removing the primary HBA card  
   Oracle Database Appliance Version 1,  
   [A-46](#)

replacing a SAS HBA cables  
   Oracle Database Appliance X6-2L, [5-8](#)

replacing a SAS HBA card  
   Oracle Database Appliance X6-2L, [5-4](#)

servicing HBA card  
   Oracle Database Appliance X6-2L, [5-4](#)

servicing HBA card cables  
   Oracle Database Appliance Version 1,  
   [A-81](#)

servicing HBA SAS cables  
   Oracle Database Appliance X6-2L, [5-4](#)

host bus adapter (HBA) cables  
 servicing SAS cables  
   Oracle Database Appliance X3-2/X4-2/  
   X5-2, [5-10](#)  
   Oracle Database Appliance X6-2 series,  
   [5-2](#)  
   Oracle Database Appliance X7-2 series,  
   [5-1](#)

hot-plug components  
 server node  
   Oracle Database Appliance Version 1,  
   [3-31](#)  
   Oracle Database Appliance X3-2/X4-2/  
   X5-2, [3-12](#)  
   Oracle Database Appliance X6-2 series,  
   [3-6](#)  
   Oracle Database Appliance X7-2 series,  
   [3-1](#)

hot-pluggable components, [3-1](#)



## I

## I/O module

- replacing in storage shelf
  - Oracle Database Appliance X3-2/X4-2/  
X5-2, X6-2-HA and X7-2-HA,  
[3-28](#)

## ILOM

- used as diagnostic tool, [7-1](#)

## L

## LEDs

## AC OK

- Oracle Database Appliance Version 1,  
[1-47](#)
- Oracle Database Appliance X3-2/X4-2,  
[1-39](#)
- Oracle Database Appliance X5-2, [1-32](#)
- Oracle Database Appliance X6-2-HA,  
[1-24](#)
- Oracle Database Appliance X6-2L, [1-20](#)
- Oracle Database Appliance X6-2S/  
X6-2M, [1-16](#)
- Oracle Database Appliance X7-2-HA, [1-9](#)
- Oracle Database Appliance X7-2S/  
X7-2M, [1-4](#)

## Activity

- Oracle Database Appliance Version 1,  
[1-47](#)
- Oracle Database Appliance X3-2/X4-2,  
[1-36](#)
- Oracle Database Appliance X5-2, [1-30](#)
- Oracle Database Appliance X6-2-HA,  
[1-22](#)
- Oracle Database Appliance X6-2L, [1-18](#)
- Oracle Database Appliance X6-2S/  
X6-2M, [1-14](#)
- Oracle Database Appliance X7-2-HA, [1-6](#)
- Oracle Database Appliance X7-2S/  
X7-2M, [1-2](#)

## CPU

- Oracle Database Appliance X3-2/X4-2/  
X5-2, [5-10](#)
- Oracle Database Appliance X6-2 series,  
[5-2](#)
- Oracle Database Appliance X7-2 series,  
[5-1](#)

## DC OK

- Oracle Database Appliance Version 1,  
[1-47](#)
- Oracle Database Appliance X3-2/X4-2,  
[1-39](#)
- Oracle Database Appliance X5-2, [1-32](#)

LEDs (*continued*)DC OK (*continued*)

- Oracle Database Appliance X6-2-HA,  
[1-24](#)
- Oracle Database Appliance X6-2L, [1-20](#)
- Oracle Database Appliance X6-2S/  
X6-2M, [1-16](#)
- Oracle Database Appliance X7-2-HA, [1-9](#)
- Oracle Database Appliance X7-2S/  
X7-2M, [1-4](#)

## DIMM

- Oracle Database Appliance Version 1,  
[4-5](#)
- Oracle Database Appliance X3-2/X4-2/  
X5-2, [4-3](#)
- Oracle Database Appliance X6-2 series,  
[4-2](#)
- Oracle Database Appliance X7-2 series,  
[4-1](#)

## Ethernet ports

- Oracle Database Appliance Version 1,  
[1-51](#)
- Oracle Database Appliance X3-2/X4-2,  
[1-39](#)
- Oracle Database Appliance X5-2, [1-32](#)
- Oracle Database Appliance X6-2-HA,  
[1-24](#)
- Oracle Database Appliance X6-2L, [1-20](#)
- Oracle Database Appliance X6-2S/  
X6-2M, [1-16](#)
- Oracle Database Appliance X7-2-HA, [1-9](#)
- Oracle Database Appliance X7-2S/  
X7-2M, [1-4](#)

## fans

- Oracle Database Appliance Version 1,  
[1-46](#)
- Oracle Database Appliance X3-2/X4-2,  
[1-36](#)
- Oracle Database Appliance X5-2, [1-30](#)
- Oracle Database Appliance X6-2-HA,  
[1-22](#)
- Oracle Database Appliance X6-2L, [1-18](#)
- Oracle Database Appliance X6-2S/  
X6-2M/, [1-14](#)
- Oracle Database Appliance X7-2-HA, [1-6](#)
- Oracle Database Appliance X7-2S/  
X7-2M/, [1-2](#)

## general status

- Oracle Database Appliance X3-2/X4-2,  
[1-36](#)
- Oracle Database Appliance X5-2, [1-30](#)
- Oracle Database Appliance X6-2-HA,  
[1-22](#)
- Oracle Database Appliance X6-2L, [1-18](#)



LEDs (*continued*)general status (*continued*)

- Oracle Database Appliance X6-2S/  
X6-2M, [1-14](#)
- Oracle Database Appliance X7-2-HA, [1-6](#)
- Oracle Database Appliance X7-2S/  
X7-2M, [1-2](#)

## internal

- Oracle Database Appliance Version 1,  
[1-50](#)
- Oracle Database Appliance X6-2 series,  
[5-2](#)
- Oracle Database Appliance X7-2 series,  
[5-1](#)

## Locate

- Oracle Database Appliance Version 1,  
[1-44](#)
- Oracle Database Appliance X3-2/X4-2,  
[1-36](#)
- Oracle Database Appliance X5-2, [1-30](#)
- Oracle Database Appliance X6-2-HA,  
[1-22](#)
- Oracle Database Appliance X6-2L, [1-18](#)
- Oracle Database Appliance X6-2S/  
X6-2M, [1-14](#)
- Oracle Database Appliance X7-2-HA, [1-6](#)
- Oracle Database Appliance X7-2S/  
X7-2M, [1-2](#)

## OK

- Oracle Database Appliance Version 1,  
[1-46](#)
- Oracle Database Appliance X3-2/X4-2,  
[1-36](#)
- Oracle Database Appliance X5-2, [1-30](#)
- Oracle Database Appliance X6-2-HA,  
[1-22](#)
- Oracle Database Appliance X6-2L, [1-18](#)
- Oracle Database Appliance X6-2S/  
X6-2M, [1-14](#)
- Oracle Database Appliance X7-2-HA, [1-6](#)
- Oracle Database Appliance X7-2S/  
X7-2M, [1-2](#)
- Oracle Database Appliance Version 1, [1-43](#)
- Oracle Database Appliance X3-2/X4-2, [1-36](#)
- Oracle Database Appliance X5-2, [1-29](#)
- Oracle Database Appliance X6-2-HA, [1-21](#)
- Oracle Database Appliance X6-2S/X6-2M/  
X6-2L, [1-13](#)
- Oracle Database Appliance X7-2-HA, [1-6](#)
- Oracle Database Appliance X7-2S/X7-2M,  
[1-1](#)
- Over Temperature
  - Oracle Database Appliance Version 1,  
[1-44](#)

LEDs (*continued*)Over Temperature (*continued*)

- Oracle Database Appliance X3-2/X4-2,  
[1-36](#)
- Oracle Database Appliance X5-2, [1-30](#)
- Oracle Database Appliance X6-2-HA,  
[1-22](#)
- Oracle Database Appliance X6-2L, [1-18](#)
- Oracle Database Appliance X6-2S/  
X6-2M, [1-14](#)
- Oracle Database Appliance X7-2-HA, [1-6](#)
- Oracle Database Appliance X7-2S/  
X7-2M, [1-2](#)

## power supplies

- Oracle Database Appliance X3-2/X4-2,  
[1-36](#)
- Oracle Database Appliance X5-2, [1-30](#)
- Oracle Database Appliance X6-2-HA,  
[1-22](#)
- Oracle Database Appliance X6-2L, [1-18](#)
- Oracle Database Appliance X6-2S/  
X6-2M, [1-14](#)
- Oracle Database Appliance X7-2-HA, [1-6](#)
- Oracle Database Appliance X7-2S/  
X7-2M, [1-2](#)

## Power/OK

- Oracle Database Appliance Version 1,  
[1-44](#)
- Oracle Database Appliance X3-2/X4-2,  
[1-36](#)
- Oracle Database Appliance X5-2, [1-30](#)
- Oracle Database Appliance X6-2-HA,  
[1-22](#)
- Oracle Database Appliance X6-2L, [1-18](#)
- Oracle Database Appliance X6-2S/  
X6-2M, [1-14](#)
- Oracle Database Appliance X7-2-HA, [1-6](#)
- Oracle Database Appliance X7-2S/  
X7-2M, [1-2](#)

## Ready to Remove

- Oracle Database Appliance Version 1,  
[1-44](#), [1-47](#)
- Oracle Database Appliance X3-2/X4-2,  
[1-36](#)
- Oracle Database Appliance X5-2, [1-30](#)
- Oracle Database Appliance X6-2-HA,  
[1-22](#)
- Oracle Database Appliance X6-2L, [1-18](#)
- Oracle Database Appliance X6-2S/  
X6-2M, [1-14](#)
- Oracle Database Appliance X7-2-HA, [1-6](#)
- Oracle Database Appliance X7-2S/  
X7-2M, [1-2](#)

## rear component failure

## LEDs (continued)

- rear component failure (continued)
  - Oracle Database Appliance Version 1, [1-44](#)
  - Oracle Database Appliance X3-2/X4-2, [1-36](#)
  - Oracle Database Appliance X5-2, [1-30](#)
  - Oracle Database Appliance X6-2-HA, [1-22](#)
  - Oracle Database Appliance X6-2L, [1-18](#)
  - Oracle Database Appliance X6-2S/X6-2M, [1-14](#)
  - Oracle Database Appliance X7-2-HA, [1-6](#)
  - Oracle Database Appliance X7-2S/X7-2M, [1-2](#)
- server node rear Locate
  - Oracle Database Appliance Version 1, [1-48](#)
  - Oracle Database Appliance X3-2/X4-2, [1-36](#)
  - Oracle Database Appliance X5-2, [1-30](#)
  - Oracle Database Appliance X6-2-HA, [1-22](#)
  - Oracle Database Appliance X6-2L, [1-18](#)
  - Oracle Database Appliance X6-2S/X6-2M, [1-14](#)
  - Oracle Database Appliance X7-2-HA, [1-6](#)
  - Oracle Database Appliance X7-2S/X7-2M, [1-2](#)
- server node rear Locate push to test
  - Oracle Database Appliance Version 1, [1-48](#)
- server node rear Power/OK
  - Oracle Database Appliance Version 1, [1-48](#)
  - Oracle Database Appliance X3-2/X4-2, [1-36](#)
  - Oracle Database Appliance X5-2, [1-30](#)
  - Oracle Database Appliance X6-2-HA, [1-22](#)
  - Oracle Database Appliance X6-2S/X6-2M, [1-14](#), [1-18](#)
  - Oracle Database Appliance X7-2-HA, [1-6](#)
  - Oracle Database Appliance X7-2S/X7-2M, [1-2](#)
- server node rear Ready to Remove
  - Oracle Database Appliance Version 1, [1-48](#)
- server node rear Service Required
  - Oracle Database Appliance Version 1, [1-48](#)
  - Oracle Database Appliance X3-2/X4-2, [1-36](#)
  - Oracle Database Appliance X5-2, [1-30](#)

## LEDs (continued)

- server node rear Service Required (continued)
  - Oracle Database Appliance X6-2-HA, [1-22](#)
  - Oracle Database Appliance X6-2L, [1-18](#)
  - Oracle Database Appliance X6-2S/X6-2M, [1-14](#)
  - Oracle Database Appliance X7-2-HA, [1-6](#)
  - Oracle Database Appliance X7-2S/X7-2M, [1-2](#)
- server node Service Required
  - Oracle Database Appliance X3-2/X4-2, [1-36](#)
  - Oracle Database Appliance X5-2, [1-30](#)
  - Oracle Database Appliance X6-2-HA, [1-22](#)
  - Oracle Database Appliance X6-2L, [1-18](#)
  - Oracle Database Appliance X6-2S/X6-2M, [1-14](#)
  - Oracle Database Appliance X7-2-HA, [1-6](#)
  - Oracle Database Appliance X7-2S/X7-2M, [1-2](#)
- Service Required
  - Oracle Database Appliance Version 1, [1-44](#), [1-46](#), [1-47](#)
- SP OK/Fault
  - Oracle Database Appliance Version 1, [1-44](#)
  - Oracle Database Appliance X3-2/X4-2, [1-36](#)
  - Oracle Database Appliance X5-2, [1-30](#)
  - Oracle Database Appliance X6-2-HA, [1-22](#)
  - Oracle Database Appliance X6-2L, [1-18](#)
  - Oracle Database Appliance X6-2S/X6-2M, [1-14](#)
  - Oracle Database Appliance X7-2-HA, [1-6](#)
  - Oracle Database Appliance X7-2S/X7-2M, [1-2](#)
- storage and boot drives
  - Oracle Database Appliance Version 1, [1-47](#)
- storage devices
  - Oracle Database Appliance X3-2/X4-2, [1-36](#)
  - Oracle Database Appliance X5-2, [1-30](#)
  - Oracle Database Appliance X6-2-HA, [1-22](#)
  - Oracle Database Appliance X6-2L, [1-18](#)
  - Oracle Database Appliance X6-2S/X6-2M, [1-14](#)
  - Oracle Database Appliance X7-2-HA, [1-6](#)
  - Oracle Database Appliance X7-2S/X7-2M, [1-2](#)
- storage shelf back panel

LEDs (*continued*)storage shelf back panel (*continued*)Oracle Database Appliance X3-2/X4-2,  
[1-42](#)Oracle Database Appliance X5-2, [1-35](#)Oracle Database Appliance X6-2-HA,  
[1-28](#)Oracle Database Appliance X7-2-HA,  
[1-12](#)

storage shelf front panel

Oracle Database Appliance X3-2/X4-2,  
[1-41](#)Oracle Database Appliance X5-2, [1-33](#)Oracle Database Appliance X6-2-HA,  
[1-26](#)Oracle Database Appliance X7-2-HA,  
[1-10](#)

---

M

## motherboard assembly

installing components

Oracle Database Appliance Version 1,  
[A-93](#)

removing components

Oracle Database Appliance Version 1,  
[A-92](#)

servicing

Oracle Database Appliance Version 1,  
[A-90](#)Oracle Database Appliance X3-2/X4-2/  
X5-2, [5-10](#)Oracle Database Appliance X6-2 series,  
[5-2](#)Oracle Database Appliance X7-2 series,  
[5-1](#)

---

N

## network ports

naming and boot order

Oracle Database Appliance Version 1,  
[A-109](#)Oracle Database Appliance X3-2/X4-2/  
X5-2, [8-5](#)Oracle Database Appliance X6-2 series,  
[8-4](#)Oracle Database Appliance X7-2 series,  
[8-2](#)

## NVMe drives

adding to server node

Oracle Database Appliance X6-2 series,  
[3-8](#)Oracle Database Appliance X7-2 series,  
[3-2](#)NVMe drives (*continued*)

replacing in server node

Oracle Database Appliance X6-2 series,  
[3-8](#)Oracle Database Appliance X7-2 series,  
[3-2](#)

---

O

## option ROM settings

configuring

Oracle Database Appliance Version 1,  
[A-117](#)Oracle Database Appliance X3-2/X4-2/  
X5-2, [8-5](#)Oracle Database Appliance X6-2 series,  
[8-3](#)Oracle Database Appliance X7-2 series,  
[8-2](#)

Oracle Database Appliance Version 1

servicing, [A-1](#)Oracle Integrated Lights Out Manager (Oracle  
ILOM)

server node power off procedures

Oracle Database Appliance Version 1,  
[A-5](#)Oracle Database Appliance X3-2/X4-2/  
X5-2, [2-3](#)Oracle Database Appliance X6-2 series,  
[2-2](#)Oracle Database Appliance X7-2 series,  
[2-1](#)

server node power on procedures

dual node Oracle Database Appliance  
with storage shelf, [6-4](#)Oracle Database Appliance Version 1,  
[A-99](#)Oracle Database Appliance X3-2/X4-2/  
X5-2, [6-3](#)Oracle Database Appliance X6-2 series,  
[6-2](#)Oracle Database Appliance X7-2 series,  
[6-1](#)SP reset, [7-3](#)used as diagnostic tool, [7-1](#)

---

PPc-Check, [7-1](#)

PCIe cards

clearing faults

Oracle Database Appliance Version 1,  
[A-44](#)

PCIe cards (*continued*)clearing faults (*continued*)

Oracle Database Appliance X3-2/X4-2/  
X5-2, X6-2 series and X7-2  
series, [5-11](#)

installing in Oracle Database Appliance X6-2  
series, [5-2](#)

installing in Oracle Database Appliance X7-2  
series, [5-1](#)

## installing in PCIe riser

Oracle Database Appliance Version 1,  
[4-5](#), [A-44](#)

Oracle Database Appliance X3-2/X4-2/  
X5-2, [4-3](#)

Oracle Database Appliance X6-2 series,  
[4-2](#)

Oracle Database Appliance X7-2 series,  
[4-1](#)

## installing the primary HBA card

Oracle Database Appliance Version 1,  
[A-47](#)

## primary and secondary HBA

Oracle Database Appliance Version 1,  
[A-42](#)

## removing from PCIe riser

Oracle Database Appliance Version 1,  
[4-5](#), [A-43](#)

Oracle Database Appliance X3-2/X4-2/  
X5-2, [4-3](#)

Oracle Database Appliance X6-2 series,  
[4-2](#)

Oracle Database Appliance X7-2 series,  
[4-1](#)

removing in Oracle Database Appliance X6-2  
series, [5-2](#)

removing in Oracle Database Appliance X7-2  
series, [5-1](#)

## removing the primary HBA card

Oracle Database Appliance Version 1,  
[A-46](#)

## servicing

Oracle Database Appliance Version 1,  
[4-5](#), [A-41](#)

Oracle Database Appliance X3-2/X4-2/  
X5-2, [4-3](#)

Oracle Database Appliance X6-2 series,  
[4-2](#)

Oracle Database Appliance X7-2 series,  
[4-1](#)

## PCIe riser

## clearing faults

Oracle Database Appliance Version 1,  
[A-40](#)

PCIe riser (*continued*)clearing faults (*continued*)

Oracle Database Appliance X3-2/X4-2/  
X5-2, X6-2 series and X7-2  
series, [5-11](#)

## installing

Oracle Database Appliance Version 1,  
[4-5](#), [A-40](#)

Oracle Database Appliance X3-2/X4-2/  
X5-2, [4-3](#)

Oracle Database Appliance X6-2 series,  
[4-2](#)

Oracle Database Appliance X7-2 series,  
[4-1](#)

## removing

Oracle Database Appliance Version 1,  
[4-5](#), [A-38](#)

Oracle Database Appliance X3-2/X4-2/  
X5-2, [4-3](#)

Oracle Database Appliance X6-2 series,  
[4-2](#)

Oracle Database Appliance X7-2 series,  
[4-1](#)

## servicing

Oracle Database Appliance Version 1,  
[4-5](#), [A-37](#)

Oracle Database Appliance X3-2/X4-2/  
X5-2, [4-3](#)

Oracle Database Appliance X6-2 series,  
[4-2](#)

Oracle Database Appliance X7-2 series,  
[4-1](#)

## power distribution board

## installing

Oracle Database Appliance Version 1,  
[A-66](#)

## removing

Oracle Database Appliance Version 1,  
[A-64](#)

## servicing

Oracle Database Appliance Version 1,  
[A-63](#)

## power off

## appliance

Oracle Database Appliance Version 1,  
[A-8](#), [A-10](#)

## power on

Oracle Database Appliance Version 1, [A-99](#)  
returning the system to operation, [6-1](#)

## power supplies

## replacing in server node

Oracle Database Appliance Version 1,  
[3-31](#), [A-25](#)

Oracle Database Appliance X3-2/X4-2/  
X5-2, [3-12](#)

power supplies (*continued*)  
 replacing in server node (*continued*)  
 Oracle Database Appliance X6-2 series, [3-6](#)  
 Oracle Database Appliance X7-2 series, [3-1](#)  
 replacing in storage shelf  
 Oracle Database Appliance X3-2/X4-2/X5-2, X6-2-HA and X7-2-HA, [3-24](#)  
 server node  
 Oracle Database Appliance Version 1, [3-31](#)  
 Oracle Database Appliance X3-2/X4-2/X5-2, [3-12](#)  
 Oracle Database Appliance X6-2 series, [3-6](#)  
 Oracle Database Appliance X7-2 series, [3-1](#)  
 status indicators  
 Oracle Database Appliance Version 1, [1-47](#)  
 Oracle Database Appliance X3-2/X4-2, [1-36](#), [1-39](#)  
 Oracle Database Appliance X5-2, [1-30](#), [1-32](#)  
 Oracle Database Appliance X6-2-HA, [1-22](#), [1-24](#)  
 Oracle Database Appliance X6-2L, [1-18](#), [1-20](#)  
 Oracle Database Appliance X6-2S/X6-2M, [1-14](#), [1-16](#)  
 Oracle Database Appliance X7-2-HA, [1-6](#), [1-9](#)  
 Oracle Database Appliance X7-2S/X7-2M, [1-2](#), [1-4](#)  
 power supply  
 detecting faults using LEDs  
 Oracle Database Appliance Version 1, [A-26](#)  
 installing  
 Oracle Database Appliance Version 1, [A-27](#)  
 removing  
 Oracle Database Appliance Version 1, [A-26](#)  
 power-on self test events  
 Oracle Database Appliance Version 1, [A-102](#)  
 power-on self-test (POST), [7-1](#)  
 power-on self-test (POST) events  
 Oracle Database Appliance X3-2/X4-2/X5-2, X6 series and X7 series, [7-1](#)  
 powering off  
 emergency shutdown

powering off (*continued*)  
 emergency shutdown (*continued*)  
 Oracle Database Appliance Version 1, [A-5](#)  
 Oracle Database Appliance X3-2/X4-2/X5-2, [2-3](#)  
 Oracle Database Appliance X6-2 series, [2-2](#)  
 Oracle Database Appliance X7-2 series, [2-1](#)  
 graceful shutdown  
 Oracle Database Appliance Version 1, [A-5](#)  
 Oracle Database Appliance X3-2/X4-2/X5-2, [2-3](#)  
 Oracle Database Appliance X6-2 series, [2-2](#)  
 Oracle Database Appliance X7-2 series, [2-1](#)  
 powering on  
 dual node Oracle Database Appliance with storage shelf, [6-4](#)  
 Oracle Database Appliance Version 1, [6-5](#)  
 Oracle Database Appliance X3-2/X4-2/X5-2, [6-3](#)  
 Oracle Database Appliance X6-2 series, [6-2](#)  
 Oracle Database Appliance X7-2 series, [6-1](#)

## R

---

replaceable components  
 cold service components  
 Oracle Database Appliance Version 1, [4-5](#), [A-2](#)  
 Oracle Database Appliance X3-2/X4-2/X5-2, [4-3](#)  
 Oracle Database Appliance X6-2 series, [4-2](#)  
 Oracle Database Appliance X7-2 series, [4-1](#)  
 hot service components  
 Oracle Database Appliance Version 1, [3-31](#), [A-2](#)  
 Oracle Database Appliance X3-2/X4-2/X5-2, [3-12](#)  
 Oracle Database Appliance X6-2 series, [3-6](#)  
 Oracle Database Appliance X7-2 series, [3-1](#)  
 replacing  
 hot and cold service components  
 Oracle Database Appliance Version 1, [A-2](#)  
 Oracle Database Appliance X3-2/X4-2/X5-2, [2-3](#)

replacing (*continued*)  
 hot and cold service components (*continued*)  
 Oracle Database Appliance X6-2 series,  
[2-2](#)  
 Oracle Database Appliance X7-2 series,  
[2-1](#)

required tools  
 servicing components  
 Oracle Database Appliance Version 1,  
[A-4](#), [A-5](#)  
 Oracle Database Appliance X3-2/X4-2/  
 X5-2, [2-3](#)  
 Oracle Database Appliance X6-2 series,  
[2-2](#)  
 Oracle Database Appliance X7-2 series,  
[2-1](#)

reset Oracle ILOM SP, [7-3](#)

## S

### safety information

servicing  
 Oracle Database Appliance Version 1,  
[A-4](#)  
 Oracle Database Appliance X3-2/X4-2/  
 X5-2, [2-3](#)  
 Oracle Database Appliance X6-2 series,  
[2-2](#)  
 Oracle Database Appliance X7-2 series,  
[2-1](#)

### SAS expander cable

installing  
 Oracle Database Appliance Version 1,  
[A-87](#)  
 removing  
 Oracle Database Appliance Version 1,  
[A-86](#)  
 servicing SAS expander cable  
 Oracle Database Appliance Version 1,  
[A-85](#), [A-87](#)

### server node

back panel indicators  
 Oracle Database Appliance Version 1,  
[1-48](#)  
 Oracle Database Appliance X3-2/X4-2,  
[1-36](#)  
 Oracle Database Appliance X5-2, [1-30](#)  
 Oracle Database Appliance X6-2-HA,  
[1-22](#)  
 Oracle Database Appliance X6-2L, [1-18](#)  
 Oracle Database Appliance X6-2S/  
 X6-2M, [1-14](#)  
 Oracle Database Appliance X7-2-HA, [1-6](#)  
 Oracle Database Appliance X7-2S/  
 X7-2M, [1-2](#)

### server node (*continued*)

CPU LEDs  
 Oracle Database Appliance X3-2/X4-2/  
 X5-2, [5-10](#)  
 Oracle Database Appliance X6-2 series,  
[5-2](#)  
 Oracle Database Appliance X7-2 series,  
[5-1](#)  
 DIMM internal LEDs  
 Oracle Database Appliance Version 1,  
[4-5](#)  
 Oracle Database Appliance X3-2/X4-2/  
 X5-2, [4-3](#)  
 Oracle Database Appliance X6-2 series,  
[4-2](#)  
 Oracle Database Appliance X7-2 series,  
[4-1](#)

### installing a boot drive

Oracle Database Appliance Version 1,  
[A-21](#)

### installing a storage drive

Oracle Database Appliance Version 1,  
[A-18](#)

### installing in the chassis

Oracle Database Appliance Version 1,  
[A-97](#)

### internal LEDs

Oracle Database Appliance Version 1,  
[1-50](#)  
 Oracle Database Appliance X3-2/X4-2,  
[1-36](#)  
 Oracle Database Appliance X5-2, [1-30](#)  
 Oracle Database Appliance X6-2 series,  
[5-2](#)  
 Oracle Database Appliance X6-2-HA,  
[1-22](#)  
 Oracle Database Appliance X6-2L, [1-18](#)  
 Oracle Database Appliance X6-2S/  
 X6-2M, [1-14](#)  
 Oracle Database Appliance X7-2 series,  
[5-1](#)  
 Oracle Database Appliance X7-2-HA, [1-6](#)  
 Oracle Database Appliance X7-2S/  
 X7-2M, [1-2](#)

### powering off

Oracle Database Appliance Version 1,  
[A-5](#)  
 Oracle Database Appliance X3-2/X4-2/  
 X5-2, [2-3](#)  
 Oracle Database Appliance X6-2 series,  
[2-2](#)  
 Oracle Database Appliance X7-2 series,  
[2-1](#)

### reconnecting power and data cables



- server node (*continued*)
  - reconnecting power and data cables (*continued*)
    - Oracle Database Appliance Version 1, [A-99](#)
    - Oracle Database Appliance X3-2/X4-2/X5-2, [6-3](#)
    - Oracle Database Appliance X6-2 series, [6-2](#)
    - Oracle Database Appliance X7-2 series, [6-1](#)
  - reinstalling in rack
    - Oracle Database Appliance X3-2/X4-2/X5-2, [6-3](#)
    - Oracle Database Appliance X6-2 series, [6-2](#)
    - Oracle Database Appliance X7-2 series, [6-1](#)
  - reinstalling in the chassis
    - Oracle Database Appliance Version 1, [6-5](#)
  - removing a boot drive
    - Oracle Database Appliance Version 1, [A-20](#)
  - removing a storage drive
    - Oracle Database Appliance Version 1, [A-17](#)
  - removing from chassis
    - Oracle Database Appliance Version 1, [A-9](#)
  - removing from rack
    - Oracle Database Appliance X3-2/X4-2/X5-2, [2-3](#)
    - Oracle Database Appliance X6-2 series, [2-2](#)
    - Oracle Database Appliance X7-2 series, [2-1](#)
  - removing the top cover
    - Oracle Database Appliance Version 1, [A-12](#)
    - Oracle Database Appliance X3-2/X4-2/X5-2, [2-3](#)
    - Oracle Database Appliance X6-2 series, [2-2](#)
    - Oracle Database Appliance X7-2 series, [2-1](#)
  - removing the top cover middle section
    - Oracle Database Appliance Version 1, [A-13](#)
  - slide into rack from maintenance position
    - Oracle Database Appliance X3-2/X4-2/X5-2, [6-3](#)
    - Oracle Database Appliance X6-2 series, [6-2](#)
    - Oracle Database Appliance X7-2 series, [6-1](#)
- server node (*continued*)
  - slide out from rack to maintenance position
    - Oracle Database Appliance X3-2/X4-2/X5-2, [2-3](#)
    - Oracle Database Appliance X6-2 series, [2-2](#)
    - Oracle Database Appliance X7-2 series, [2-1](#)
- server node top cover
  - installing
    - Oracle Database Appliance Version 1, [A-96](#)
- service processor reset, [7-3](#)
- servicing
  - boot disk backplane
    - Oracle Database Appliance Version 1, [A-61](#)
  - cables
    - Oracle Database Appliance Version 1, [A-78](#)
  - CPUs
    - Oracle Database Appliance Version 1, [A-55](#)
    - Oracle Database Appliance X3-2/X4-2/X5-2, [5-10](#)
    - Oracle Database Appliance X6-2 series, [5-2](#)
    - Oracle Database Appliance X7-2 series, [5-1](#)
  - customer-replaceable server node
    - components
      - Oracle Database Appliance Version 1, [A-28](#)
  - DIMMs
    - Oracle Database Appliance Version 1, [4-5](#), [A-30](#)
    - Oracle Database Appliance X3-2/X4-2/X5-2, [4-3](#)
    - Oracle Database Appliance X6-2 series, [4-2](#)
    - Oracle Database Appliance X7-2 series, [4-1](#)
  - disk backplane
    - Oracle Database Appliance X3-2/X4-2/X5-2, [5-10](#)
    - Oracle Database Appliance X6-2 series, [5-2](#)
    - Oracle Database Appliance X7-2 series, [5-1](#)
  - disk midplane module
    - Oracle Database Appliance Version 1, [A-67](#)
  - disk midplane module HDD cable
    - Oracle Database Appliance Version 1, [A-72](#)

servicing (*continued*)

- fan cables
  - Oracle Database Appliance Version 1, [A-79](#)
- fan modules
  - Oracle Database Appliance Version 1, [A-22](#)
- field-replaceable components
  - Oracle Database Appliance Version 1, [A-51](#)
- front indicator panel
  - Oracle Database Appliance Version 1, [A-74](#)
- front indicator panels
  - Oracle Database Appliance X3-2/X4-2/X5-2, [5-10](#)
  - Oracle Database Appliance X6-2 series, [5-2](#)
  - Oracle Database Appliance X7-2 series, [5-1](#)
- FRUs
  - Oracle Database Appliance Version 1, [5-12](#)
- HBA card cables
  - Oracle Database Appliance Version 1, [A-81](#)
- HBA SAS cables
  - Oracle Database Appliance X3-2/X4-2/X5-2, [5-10](#)
- hot-plug components, [3-1](#)
  - Oracle Database Appliance Version 1, [3-31](#)
  - Oracle Database Appliance X3-2/X4-2/X5-2, [3-12](#)
  - Oracle Database Appliance X6-2 series, [3-6](#)
  - Oracle Database Appliance X7-2 series, [3-1](#)
- hot-plug components, storage shelf, [3-13](#)
- hotplug components
  - Oracle Database Appliance Version 1, [A-14](#)
- installing a server node in the chassis
  - Oracle Database Appliance Version 1, [A-96](#)
- installing a server node top cover
  - Oracle Database Appliance Version 1, [A-95](#), [A-96](#)
- managing component faults, [5-11](#)
- motherboard assembly
  - Oracle Database Appliance X3-2/X4-2/X5-2, [5-10](#)
  - Oracle Database Appliance X6-2 series, [5-2](#)

servicing (*continued*)

- motherboard assembly (*continued*)
  - Oracle Database Appliance X7-2 series, [5-1](#)
- non-hotplug customer replaceable components, [4-1](#)
- non-hotplug field replaceable components, [5-1](#)
- NVMe cables
  - Oracle Database Appliance X6-2 series, [5-2](#)
  - Oracle Database Appliance X7-2 series, [5-1](#)
- Oracle Database Appliance Version 1, [A-1](#)
- PCIe cards
  - Oracle Database Appliance Version 1, [4-5](#), [A-41](#)
  - Oracle Database Appliance X3-2/X4-2/X5-2, [4-3](#)
  - Oracle Database Appliance X6-2 series, [4-2](#)
  - Oracle Database Appliance X7-2 series, [4-1](#)
- PCIe riser
  - Oracle Database Appliance Version 1, [4-5](#), [A-37](#)
  - Oracle Database Appliance X3-2/X4-2/X5-2, [4-3](#)
  - Oracle Database Appliance X6-2 series, [4-2](#)
  - Oracle Database Appliance X7-2 series, [4-1](#)
- power distribution board
  - Oracle Database Appliance Version 1, [A-63](#)
- powering on server node
  - Oracle Database Appliance Version 1, [A-98](#), [A-102](#)
- preparing for service
  - Oracle Database Appliance Version 1, [2-4](#)
  - Oracle Database Appliance X3-2/X4-2/X5-2, [2-3](#)
  - Oracle Database Appliance X6-2 series, [2-2](#)
  - Oracle Database Appliance X7-2 series, [2-1](#)
- preparing the system, [2-1](#)
  - Oracle Database Appliance Version 1, [A-1](#)
- removing a server node from chassis
  - Oracle Database Appliance Version 1, [A-9](#)
  - Oracle Database Appliance X3-2/X4-2/X5-2, [2-3](#)



servicing (*continued*)

- removing a server node from chassis (*continued*)
  - Oracle Database Appliance X6-2 series, [2-2](#)
  - Oracle Database Appliance X7-2 series, [2-1](#)
- removing the top cover
  - Oracle Database Appliance Version 1, [A-11](#)
  - Oracle Database Appliance X3-2/X4-2/X5-2, [2-3](#)
  - Oracle Database Appliance X6-2 series, [2-2](#)
  - Oracle Database Appliance X7-2 series, [2-1](#)
- removing the top cover middle section
  - Oracle Database Appliance Version 1, [A-12](#)
- replacing a power supply in storage shelf
  - Oracle Database Appliance X3-2/X4-2/X5-2, X6-2-HA and X7-2-HA, [3-24](#)
- replacing disk drives in a storage shelf
  - Oracle Database Appliance X3-2/X4-2/X5-2 and X6-2-HA, [3-21](#)
- replacing fans in server node
  - Oracle Database Appliance Version 1, [3-31](#)
  - Oracle Database Appliance X3-2/X4-2/X5-2, [3-12](#)
  - Oracle Database Appliance X6-2 series, [3-6](#)
  - Oracle Database Appliance X7-2 series, [3-1](#)
- replacing hard disk drives in server node
  - Oracle Database Appliance Version 1, [3-31](#), [A-15](#)
  - Oracle Database Appliance X3-2/X4-2/X5-2, [3-12](#)
  - Oracle Database Appliance X6-2 series, [3-6](#)
  - Oracle Database Appliance X7-2 series, [3-1](#)
- replacing I/O module in storage shelf
  - Oracle Database Appliance X3-2/X4-2/X5-2, X6-2-HA and X7-2-HA, [3-28](#)
- replacing power supplies in server node
  - Oracle Database Appliance Version 1, [3-31](#), [A-25](#)
  - Oracle Database Appliance X3-2/X4-2/X5-2, [3-12](#)
  - Oracle Database Appliance X6-2 series, [3-6](#)

servicing (*continued*)

- replacing power supplies in server node (*continued*)
  - Oracle Database Appliance X7-2 series, [3-1](#)
- resetting the SP, [7-1](#)
- returning the appliance to operation
  - Oracle Database Appliance Version 1, [6-5](#), [A-94](#)
  - Oracle Database Appliance X3-2/X4-2/X5-2, [6-3](#)
  - Oracle Database Appliance X6-2 series, [6-2](#)
  - Oracle Database Appliance X7-2 series, [6-1](#)
- returning the system to operation, [6-1](#)
- SAS expander cable
  - Oracle Database Appliance Version 1, [A-85](#), [A-87](#)
- server node air ducts
  - Oracle Database Appliance Version 1, [A-52](#)
- server node battery
  - Oracle Database Appliance Version 1, [4-5](#), [A-49](#)
  - Oracle Database Appliance X3-2/X4-2/X5-2, [4-3](#)
  - Oracle Database Appliance X6-2 series, [4-2](#)
  - Oracle Database Appliance X7-2 series, [4-1](#)
- server node BIOS
  - Oracle Database Appliance Version 1, [A-101](#)
- server node motherboard
  - Oracle Database Appliance Version 1, [A-90](#)
- troubleshooting and diagnostics, [7-1](#)
- Setup
  - BIOS Setup Utility overview, [8-1](#)
  - Oracle Database Appliance Version 1, [8-6](#)
  - Oracle Database Appliance X3-2/X4-2/X5-2, [8-4](#)
  - Oracle Database Appliance X6-2 series, [8-3](#)
  - Oracle Database Appliance X7-2 series, [8-1](#)
- shut down
  - server node
    - Oracle Database Appliance Version 1, [A-6](#)
- shutdown procedures
  - emergency shutdown
    - Oracle Database Appliance Version 1, [A-5](#)

- shutdown procedures (*continued*)
  - emergency shutdown (*continued*)
    - Oracle Database Appliance X3-2/X4-2/  
X5-2, [2-3](#)
    - Oracle Database Appliance X6-2 series, [2-2](#)
    - Oracle Database Appliance X7-2 series, [2-1](#)
  - graceful shutdown
    - Oracle Database Appliance Version 1, [A-5](#)
    - Oracle Database Appliance X3-2/X4-2/  
X5-2, [2-3](#)
    - Oracle Database Appliance X6-2 series, [2-2](#)
    - Oracle Database Appliance X7-2 series, [2-1](#)
- shutting down
  - Oracle Database Appliance Version 1, [2-4](#)
  - Oracle Database Appliance X3-2/X4-2/X5-2, [2-3](#)
  - Oracle Database Appliance X6-2 series, [2-2](#)
  - Oracle Database Appliance X7-2 series, [2-1](#)
  - preparing the system for servicing, [2-1](#)
- SP LAN settings
  - configuring
    - Oracle Database Appliance Version 1, [A-115](#)
- standby power state
  - dual node Oracle Database Appliance with  
storage shelf, [6-4](#)
  - Oracle Database Appliance Version 1, [A-99](#)
  - Oracle Database Appliance X3-2/X4-2/X5-2, [6-3](#)
  - Oracle Database Appliance X6-2 series, [6-2](#)
  - Oracle Database Appliance X7-2 series, [6-1](#)
- status indicators
  - AC OK
    - Oracle Database Appliance Version 1, [1-47](#)
    - Oracle Database Appliance X3-2/X4-2, [1-39](#)
    - Oracle Database Appliance X5-2, [1-32](#)
    - Oracle Database Appliance X6-2-HA, [1-24](#)
    - Oracle Database Appliance X6-2L, [1-20](#)
    - Oracle Database Appliance X6-2S/  
X6-2M, [1-16](#)
    - Oracle Database Appliance X7-2-HA, [1-9](#)
    - Oracle Database Appliance X7-2S/  
X7-2M, [1-4](#)
  - Activity
    - Oracle Database Appliance Version 1, [1-47](#)
- status indicators (*continued*)
  - Activity (*continued*)
    - Oracle Database Appliance X3-2/X4-2, [1-39](#)
    - Oracle Database Appliance X5-2, [1-32](#)
    - Oracle Database Appliance X6-2-HA, [1-24](#)
    - Oracle Database Appliance X6-2L, [1-20](#)
    - Oracle Database Appliance X6-2S/  
X6-2M, [1-16](#)
    - Oracle Database Appliance X7-2-HA, [1-9](#)
    - Oracle Database Appliance X7-2S/  
X7-2M, [1-4](#)
- CPU
  - Oracle Database Appliance Version 1, [A-56](#)
  - Oracle Database Appliance X3-2/X4-2/  
X5-2, [5-10](#)
  - Oracle Database Appliance X6-2 series, [5-2](#)
  - Oracle Database Appliance X7-2 series, [5-1](#)
- DC OK
  - Oracle Database Appliance Version 1, [1-47](#)
  - Oracle Database Appliance X3-2/X4-2, [1-39](#)
  - Oracle Database Appliance X5-2, [1-32](#)
  - Oracle Database Appliance X6-2-HA, [1-24](#)
  - Oracle Database Appliance X6-2L, [1-20](#)
  - Oracle Database Appliance X6-2S/  
X6-2M, [1-16](#)
  - Oracle Database Appliance X7-2-HA, [1-9](#)
  - Oracle Database Appliance X7-2S/  
X7-2M, [1-4](#)
- DIMM
  - Oracle Database Appliance Version 1, [4-5](#), [A-32](#)
  - Oracle Database Appliance X3-2/X4-2/  
X5-2, [4-3](#)
  - Oracle Database Appliance X6-2 series, [4-2](#)
  - Oracle Database Appliance X7-2 series, [4-1](#)
- Ethernet ports
  - Oracle Database Appliance Version 1, [1-51](#)
  - Oracle Database Appliance X3-2/X4-2, [1-39](#)
  - Oracle Database Appliance X5-2, [1-32](#)
  - Oracle Database Appliance X6-2-HA, [1-24](#)
  - Oracle Database Appliance X6-2L, [1-20](#)

status indicators (*continued*)Ethernet ports (*continued*)

- Oracle Database Appliance X6-2S/  
X6-2M, [1-16](#)
- Oracle Database Appliance X7-2-HA, [1-9](#)
- Oracle Database Appliance X7-2S/  
X7-2M, [1-4](#)

## fans

- Oracle Database Appliance Version 1,  
[1-46](#)
- Oracle Database Appliance X3-2/X4-2,  
[1-36](#)
- Oracle Database Appliance X5-2, [1-30](#)
- Oracle Database Appliance X6-2-HA,  
[1-22](#)
- Oracle Database Appliance X6-2L, [1-18](#)
- Oracle Database Appliance X6-2S/  
X6-2M, [1-14](#)
- Oracle Database Appliance X7-2-HA, [1-6](#)
- Oracle Database Appliance X7-2S/  
X7-2M, [1-2](#)

## general status

- Oracle Database Appliance X3-2/X4-2,  
[1-36](#)
- Oracle Database Appliance X5-2, [1-30](#)
- Oracle Database Appliance X6-2-HA,  
[1-22](#)
- Oracle Database Appliance X6-2L, [1-18](#)
- Oracle Database Appliance X6-2S/  
X6-2M, [1-14](#)
- Oracle Database Appliance X7-2-HA, [1-6](#)
- Oracle Database Appliance X7-2S/  
X7-2M, [1-2](#)

## internal

- Oracle Database Appliance Version 1,  
[1-50](#)
- Oracle Database Appliance X3-2/X4-2/  
X5-2, [5-10](#)
- Oracle Database Appliance X6-2 series,  
[5-2](#)
- Oracle Database Appliance X7-2 series,  
[5-1](#)

## Locate

- Oracle Database Appliance Version 1,  
[1-44](#)
- Oracle Database Appliance X3-2/X4-2,  
[1-36](#)
- Oracle Database Appliance X5-2, [1-30](#)
- Oracle Database Appliance X6-2-HA,  
[1-22](#)
- Oracle Database Appliance X6-2L, [1-18](#)
- Oracle Database Appliance X6-2S/  
X6-2M, [1-14](#)
- Oracle Database Appliance X7-2-HA, [1-6](#)

status indicators (*continued*)Locate (*continued*)

- Oracle Database Appliance X7-2S/  
X7-2M, [1-2](#)
- Oracle Database Appliance Version 1, [1-43](#)
- Oracle Database Appliance X3-2/X4-2, [1-36](#)
- Oracle Database Appliance X5-2, [1-29](#)
- Oracle Database Appliance X6-2-HA, [1-21](#)
- Oracle Database Appliance X6-2S/X6-2M/  
X6-2L, [1-13](#)
- Oracle Database Appliance X7-2-HA, [1-6](#)
- Oracle Database Appliance X7-2S/X7-2M,  
[1-1](#)

## Over Temperature

- Oracle Database Appliance Version 1,  
[1-44](#)
- Oracle Database Appliance X3-2/X4-2,  
[1-36](#)
- Oracle Database Appliance X5-2, [1-30](#)
- Oracle Database Appliance X6-2-HA,  
[1-22](#)
- Oracle Database Appliance X6-2L, [1-18](#)
- Oracle Database Appliance X6-2S/  
X6-2M, [1-14](#)
- Oracle Database Appliance X7-2-HA, [1-6](#)
- Oracle Database Appliance X7-2S/  
X7-2M, [1-2](#)

## power supplies

- Oracle Database Appliance Version 1,  
[1-47](#)
- Oracle Database Appliance X3-2/X4-2,  
[1-36](#)
- Oracle Database Appliance X5-2, [1-30](#)
- Oracle Database Appliance X6-2-HA,  
[1-22](#)
- Oracle Database Appliance X6-2L, [1-18](#)
- Oracle Database Appliance X6-2S/  
X6-2M, [1-14](#)
- Oracle Database Appliance X7-2-HA, [1-6](#)
- Oracle Database Appliance X7-2S/  
X7-2M, [1-2](#)

## Power/OK

- Oracle Database Appliance Version 1,  
[1-44](#)
- Oracle Database Appliance X3-2/X4-2,  
[1-36](#)
- Oracle Database Appliance X5-2, [1-30](#)
- Oracle Database Appliance X6-2-HA,  
[1-22](#)
- Oracle Database Appliance X6-2L, [1-18](#)
- Oracle Database Appliance X6-2S/  
X6-2M, [1-14](#)
- Oracle Database Appliance X7-2-HA, [1-6](#)
- Oracle Database Appliance X7-2S/  
X7-2M, [1-2](#)

status indicators (*continued*)

## Ready to Remove

- Oracle Database Appliance Version 1, [1-44](#), [1-47](#)
- Oracle Database Appliance X3-2/X4-2, [1-36](#)
- Oracle Database Appliance X5-2, [1-30](#)
- Oracle Database Appliance X6-2-HA, [1-22](#)
- Oracle Database Appliance X6-2L, [1-18](#)
- Oracle Database Appliance X6-2S/  
X6-2M, [1-14](#)
- Oracle Database Appliance X7-2-HA, [1-6](#)
- Oracle Database Appliance X7-2S/  
X7-2M, [1-2](#)

## rear component failure

- Oracle Database Appliance Version 1, [1-44](#)
- Oracle Database Appliance X3-2/X4-2, [1-36](#)
- Oracle Database Appliance X5-2, [1-30](#)
- Oracle Database Appliance X6-2-HA, [1-22](#)
- Oracle Database Appliance X6-2L, [1-18](#)
- Oracle Database Appliance X6-2S/  
X6-2M, [1-14](#)
- Oracle Database Appliance X7-2-HA, [1-6](#)
- Oracle Database Appliance X7-2S/  
X7-2M, [1-2](#)

## server node

- Oracle Database Appliance Version 1, [1-44](#)

## server node rear Locate

- Oracle Database Appliance Version 1, [1-48](#)
- Oracle Database Appliance X3-2/X4-2, [1-36](#)
- Oracle Database Appliance X5-2, [1-30](#)
- Oracle Database Appliance X6-2-HA, [1-22](#)
- Oracle Database Appliance X6-2L, [1-18](#)
- Oracle Database Appliance X6-2S/  
X6-2M, [1-14](#)
- Oracle Database Appliance X7-2-HA, [1-6](#)
- Oracle Database Appliance X7-2S/  
X7-2M, [1-2](#)

## server node rear Locate push to test

- Oracle Database Appliance Version 1, [1-48](#)

## server node rear Power/OK

- Oracle Database Appliance Version 1, [1-48](#)
- Oracle Database Appliance X3-2/X4-2, [1-36](#)
- Oracle Database Appliance X5-2, [1-30](#)

status indicators (*continued*)server node rear Power/OK (*continued*)

- Oracle Database Appliance X6-2-HA, [1-22](#)
- Oracle Database Appliance X6-2L, [1-18](#)
- Oracle Database Appliance X6-2S/  
X6-2M, [1-14](#)
- Oracle Database Appliance X7-2-HA, [1-6](#)
- Oracle Database Appliance X7-2S/  
X7-2M, [1-2](#)

## server node rear Ready to Remove

- Oracle Database Appliance Version 1, [1-48](#)

## server node rear Service Required

- Oracle Database Appliance Version 1, [1-48](#)
- Oracle Database Appliance X3-2/X4-2, [1-36](#)
- Oracle Database Appliance X5-2, [1-30](#)
- Oracle Database Appliance X6-2-HA, [1-22](#)
- Oracle Database Appliance X6-2L, [1-18](#)
- Oracle Database Appliance X6-2S/  
X6-2M, [1-14](#)
- Oracle Database Appliance X7-2-HA, [1-6](#)
- Oracle Database Appliance X7-2S/  
X7-2M, [1-2](#)

## server node SP OK/Fault

- Oracle Database Appliance Version 1, [1-44](#)
- Oracle Database Appliance X3-2/X4-2, [1-36](#)
- Oracle Database Appliance X5-2, [1-30](#)
- Oracle Database Appliance X6-2-HA, [1-22](#)
- Oracle Database Appliance X6-2L, [1-18](#)
- Oracle Database Appliance X6-2S/  
X6-2M, [1-14](#)
- Oracle Database Appliance X7-2-HA, [1-6](#)
- Oracle Database Appliance X7-2S/  
X7-2M, [1-2](#)

## Service Required

- Oracle Database Appliance Version 1, [1-44](#), [1-46](#), [1-47](#)
- Oracle Database Appliance X3-2/X4-2, [1-36](#)
- Oracle Database Appliance X5-2, [1-30](#)
- Oracle Database Appliance X6-2-HA, [1-22](#)
- Oracle Database Appliance X6-2L, [1-18](#)
- Oracle Database Appliance X6-2S/  
X6-2M, [1-14](#)
- Oracle Database Appliance X7-2-HA, [1-6](#)
- Oracle Database Appliance X7-2S/  
X7-2M, [1-2](#)

- status indicators (*continued*)
    - storage devices
      - Oracle Database Appliance Version 1, [1-47](#)
      - Oracle Database Appliance X3-2/X4-2, [1-36](#)
      - Oracle Database Appliance X5-2, [1-30](#)
      - Oracle Database Appliance X6-2-HA, [1-22](#)
      - Oracle Database Appliance X6-2L, [1-18](#)
      - Oracle Database Appliance X6-2S/X6-2M, [1-14](#)
      - Oracle Database Appliance X7-2-HA, [1-6](#)
      - Oracle Database Appliance X7-2S/X7-2M, [1-2](#)
  - storage
    - adding NVMe storage to the server
      - Oracle Database Appliance X6-2 series, [3-10](#)
      - Oracle Database Appliance X7-2 series, [3-5](#)
    - replacing NVMe storage
      - Oracle Database Appliance X6-2 series, [3-8](#)
      - Oracle Database Appliance X7-2 series, [3-3](#)
  - storage drive
    - installing in server node
      - Oracle Database Appliance Version 1, [A-18](#)
    - removing from server node
      - Oracle Database Appliance Version 1, [A-17](#)
  - storage shelf
    - adding optional drives to the ODA X6-2-HA storage shelf, [3-19](#)
    - adding optional drives to the ODA X7-2-HA storage shelf, [3-15](#)
    - replacing a power supply, [3-14](#)
    - replacing a SAS I/O module, [3-14](#)
    - replacing a storage drive, [3-14](#)
    - replacing storage drives
      - Oracle Database Appliance X3-2/X4-2/X5-2 and X6-2-HA, [3-21](#)
    - servicing hot-plug components, [3-13](#)
  - storage shelf indicators
    - back panel
      - Oracle Database Appliance X3-2/X4-2, [1-42](#)
      - Oracle Database Appliance X5-2, [1-35](#)
      - Oracle Database Appliance X6-2-HA, [1-28](#)
      - Oracle Database Appliance X7-2-HA, [1-12](#)
    - front panel
  - storage shelf indicators (*continued*)
    - front panel (*continued*)
      - Oracle Database Appliance X3-2/X4-2, [1-41](#)
      - Oracle Database Appliance X5-2, [1-33](#)
      - Oracle Database Appliance X6-2-HA, [1-26](#)
      - Oracle Database Appliance X7-2-HA, [1-10](#)
- 
- ## T
- tools
    - required for service
      - Oracle Database Appliance Version 1, [A-4, A-5](#)
      - Oracle Database Appliance X3-2/X4-2/X5-2, [2-3](#)
      - Oracle Database Appliance X6-2 series, [2-2](#)
      - Oracle Database Appliance X7-2 series, [2-1](#)
  - top cover
    - install
      - Oracle Database Appliance Version 1, [6-5](#)
      - Oracle Database Appliance X3-2/X4-2/X5-2, [6-3](#)
      - Oracle Database Appliance X6-2 series, [6-2](#)
      - Oracle Database Appliance X7-2 series, [6-1](#)
    - server node
      - Oracle Database Appliance Version 1, [A-12](#)
      - Oracle Database Appliance X3-2/X4-2/X5-2, [2-3](#)
      - Oracle Database Appliance X6-2 series, [2-2](#)
      - Oracle Database Appliance X7-2 series, [2-1](#)
  - top cover middle section
    - server node
      - Oracle Database Appliance Version 1, [A-13](#)
  - troubleshooting
    - diagnostics and resetting the SP, [7-1](#)
  - Trusted Platform Module (TPM)
    - support for
      - Oracle Database Appliance Version 1, [A-110](#)
      - Oracle Database Appliance X3-2/X4-2/X5-2, [8-5](#)
      - Oracle Database Appliance X6-2 series, [8-4](#)

Trusted Platform Module (TPM) (*continued*)  
support for (*continued*)  
Oracle Database Appliance X7-2 series,  
[8-2](#)