

**Oracle® Retail AI Foundation Cloud  
Services**

Security Guide

Release 23.1.101.0

**F76914-01**

January 2023

Copyright © 2023, Oracle and/or its affiliates. All rights reserved.

Primary Author: Judith Meskill

This software and related documentation are provided under a license agreement containing restrictions on use and disclosure and are protected by intellectual property laws. Except as expressly permitted in your license agreement or allowed by law, you may not use, copy, reproduce, translate, broadcast, modify, license, transmit, distribute, exhibit, perform, publish, or display any part, in any form, or by any means. Reverse engineering, disassembly, or decompilation of this software, unless required by law for interoperability, is prohibited.

The information contained herein is subject to change without notice and is not warranted to be error-free. If you find any errors, please report them to us in writing.

If this is software or related documentation that is delivered to the U.S. Government or anyone licensing it on behalf of the U.S. Government, then the following notice is applicable:

U.S. GOVERNMENT END USERS: Oracle programs, including any operating system, integrated software, any programs installed on the hardware, and/or documentation, delivered to U.S. Government end users are "commercial computer software" pursuant to the applicable Federal Acquisition Regulation and agency-specific supplemental regulations. As such, use, duplication, disclosure, modification, and adaptation of the programs, including any operating system, integrated software, any programs installed on the hardware, and/or documentation, shall be subject to license terms and license restrictions applicable to the programs. No other rights are granted to the U.S. Government.

This software or hardware is developed for general use in a variety of information management applications. It is not developed or intended for use in any inherently dangerous applications, including applications that may create a risk of personal injury. If you use this software or hardware in dangerous applications, then you shall be responsible to take all appropriate fail-safe, backup, redundancy, and other measures to ensure its safe use. Oracle Corporation and its affiliates disclaim any liability for any damages caused by use of this software or hardware in dangerous applications.

Oracle and Java are registered trademarks of Oracle and/or its affiliates. Other names may be trademarks of their respective owners.

Intel and Intel Xeon are trademarks or registered trademarks of Intel Corporation. All SPARC trademarks are used under license and are trademarks or registered trademarks of SPARC International, Inc. AMD, Opteron, the AMD logo, and the AMD Opteron logo are trademarks or registered trademarks of Advanced Micro Devices. UNIX is a registered trademark of The Open Group.

This software or hardware and documentation may provide access to or information about content, products, and services from third parties. Oracle Corporation and its affiliates are not responsible for and expressly disclaim all warranties of any kind with respect to third-party content, products, and services unless otherwise set forth in an applicable agreement between you and Oracle. Oracle Corporation and its affiliates will not be responsible for any loss, costs, or damages incurred due to your access to or use of third-party content, products, or services, except as set forth in an applicable agreement between you and Oracle.

#### **Value-Added Reseller (VAR) Language**

##### **Oracle Retail VAR Applications**

The following restrictions and provisions only apply to the programs referred to in this section and licensed to you. You acknowledge that the programs may contain third party software (VAR applications) licensed to Oracle. Depending upon your product and its version number, the VAR applications may include:

- (i) the **MicroStrategy** Components developed and licensed by MicroStrategy Services Corporation (MicroStrategy) of McLean, Virginia to Oracle and imbedded in the MicroStrategy for Oracle Retail Data Warehouse and MicroStrategy for Oracle Retail Planning & Optimization applications.
- (ii) the **Wavelink** component developed and licensed by Wavelink Corporation (Wavelink) of Kirkland, Washington, to Oracle and imbedded in Oracle Retail Mobile Store Inventory Management.
- (iii) the software component known as **Access Via™** licensed by Access Via of Seattle, Washington, and imbedded in Oracle Retail Signs and Oracle Retail Labels and Tags.
- (iv) the software component known as **Adobe Flex™** licensed by Adobe Systems Incorporated of San Jose, California, and imbedded in Oracle Retail Promotion Planning & Optimization application.

You acknowledge and confirm that Oracle grants you use of only the object code of the VAR Applications. Oracle will not deliver source code to the VAR Applications to you. Notwithstanding any other term or condition of the agreement and this ordering document, you shall not cause or permit alteration of any VAR Applications. For purposes of this section, "alteration" refers to all alterations, translations, upgrades, enhancements, customizations or modifications of all or any portion of the VAR Applications including all reconfigurations, reassembly or reverse assembly, re-engineering or reverse engineering and recompilations or reverse compilations of the VAR Applications or any derivatives of the VAR Applications. You acknowledge that it shall be a breach of the agreement to utilize the relationship, and/or confidential information of the VAR Applications for purposes of competitive discovery.

The VAR Applications contain trade secrets of Oracle and Oracle's licensors and Customer shall not attempt, cause, or permit the alteration, decompilation, reverse engineering, disassembly or other reduction of the VAR Applications to a human perceivable form. Oracle reserves the right to replace, with functional equivalent software, any of the VAR Applications in future releases of the applicable program.



---

---

# Contents

<b>Send Us Your Comments</b> .....	vii
<b>Preface</b> .....	ix
Audience.....	ix
Documentation Accessibility .....	ix
Related Documents .....	ix
Customer Support.....	x
Improved Process for Oracle Retail AI Foundation Cloud Services Documentation Corrections .....	x
Oracle Retail AI Foundation Cloud Services Documentation on the Oracle Technology Network.....	x
Conventions.....	xi
<b>1 Security Features</b>	
<b>Technology-Specific Guidelines</b> .....	1-1
Security Features.....	1-1
Authentication and Authorization.....	1-2
<b>Oracle Retail AI Foundation Cloud Services/ORDS Integration</b> .....	1-4
<b>2 Responsibilities</b>	
<b>Retailer Responsibilities</b> .....	2-1
<b>Oracle Responsibilities</b> .....	2-1
<b>3 Oracle Retail AI Foundation Cloud Services SaaS Security</b>	
<b>Secure Product Engineering</b> .....	3-1
<b>Secure Deployment</b> .....	3-1
Physical Safeguards .....	3-2
Network Security .....	3-2
Infrastructure Security.....	3-2
Data Security.....	3-2
<b>Secure Management</b> .....	3-2
<b>Assessment and Audit</b> .....	3-3



---

---

# Send Us Your Comments

Oracle Retail AI Foundation Cloud Services Security Guide, Release 23.1.101.0

Oracle welcomes customers' comments and suggestions on the quality and usefulness of this document.

Your feedback is important, and helps us to best meet your needs as a user of our products. For example:

- Are the implementation steps correct and complete?
- Did you understand the context of the procedures?
- Did you find any errors in the information?
- Does the structure of the information help you with your tasks?
- Do you need different information or graphics? If so, where, and in what format?
- Are the examples correct? Do you need more examples?

If you find any errors or have any other suggestions for improvement, then please tell us your name, the name of the company who has licensed our products, the title and part number of the documentation and the chapter, section, and page number (if available).

---

---

**Note:** Before sending us your comments, you might like to check that you have the latest version of the document and if any concerns are already addressed. To do this, access the Online Documentation available on the Oracle Technology Network Web site. It contains the most current Documentation Library plus all documents revised or released recently.

---

---

Send your comments to us using the electronic mail address: [retail-doc\\_us@oracle.com](mailto:retail-doc_us@oracle.com)

Please give your name, address, electronic mail address, and telephone number (optional).

If you need assistance with Oracle software, then please contact your support representative or Oracle Support Services.

If you require training or instruction in using Oracle software, then please contact your Oracle local office and inquire about our Oracle University offerings. A list of Oracle offices is available on our Web site at <http://www.oracle.com>.





---

---

# Preface

This document serves as a guide for administrators, developers, and system integrators who securely administer, customize, and integrate Oracle Retail AI Foundation Cloud Services.

## Audience

This document is intended for administrators, developers, and system integrators who perform the following functions:

- Document specific security features and configuration details for the above mentioned product, in order to facilitate and support the secure operation of the Oracle Retail AI Foundation Cloud Services Product and any external compliance standards.
- Guide administrators, developers, and system integrators on secure product implementation, integration, and administration.

We assume that the readers have general knowledge of administering the underlying technologies and the application.

## Documentation Accessibility

For information about Oracle's commitment to accessibility, visit the Oracle Accessibility Program website at <http://www.oracle.com/pls/topic/lookup?ctx=acc&id=docacc>.

### Access to Oracle Support

Oracle customers that have purchased support have access to electronic support through My Oracle Support. For information, visit

<http://www.oracle.com/pls/topic/lookup?ctx=acc&id=info> or visit

<http://www.oracle.com/pls/topic/lookup?ctx=acc&id=trs> if you are hearing impaired.

## Related Documents

For more information, see the following documents in the Oracle Retail AI Foundation Cloud Services documentation set:

- *Oracle Retail AI Foundation Cloud Services Administration Guide*
- *Oracle Retail AI Foundation Cloud Services Implementation Guide*
- *Oracle Retail AI Foundation Cloud Services Release Readiness Guide*
- *Oracle Retail Analytics and Planning Cloud Services Data Interface*
- *Oracle Retail AI Foundation Cloud Services User Guide*

- *Oracle Retail AI Foundation Cloud Services Assortment and Space Optimization User Guide*
- *Oracle Retail AI Foundation Cloud Services Inventory Optimization User Guide*
- *Oracle Retail AI Foundation Cloud Services Promotion Markdown and Offer Optimization User Guide*

## Customer Support

To contact Oracle Customer Support, access My Oracle Support at the following URL:

<https://support.oracle.com>

When contacting Customer Support, please provide the following:

- Product version and program/module name
- Functional and technical description of the problem (include business impact)
- Detailed step-by-step instructions to re-create
- Exact error message received
- Screen shots of each step you take

## Improved Process for Oracle Retail AI Foundation Cloud Services Documentation Corrections

To more quickly address critical corrections to Oracle Retail AI Foundation Cloud Services documentation content, Oracle Retail AI Foundation Cloud Services documentation may be republished whenever a critical correction is needed. For critical corrections, the republication of an Oracle Retail AI Foundation Cloud Services document may at times not be attached to a numbered software release; instead, the Oracle Retail AI Foundation Cloud Services document will simply be replaced on the Oracle Technology Network Web site, or, in the case of Data Models, to the applicable My Oracle Support Documentation container where they reside.

Oracle Retail AI foundation documentation is available on the Oracle Technology Network at the following URL:

<http://www.oracle.com/technetwork/documentation/oracle-retail-100266.html>

An updated version of the applicable Oracle Retail AI Foundation Cloud Services document is indicated by Oracle part number, as well as print date (month and year). An updated version uses the same part number, with a higher-numbered suffix. For example, part number E123456-02 is an updated version of a document with part number E123456-01.

If a more recent version of a document is available, that version supersedes all previous versions.

## Oracle Retail AI Foundation Cloud Services Documentation on the Oracle Technology Network

Oracle AI Foundation Cloud Services product documentation is available on the following web site:

<http://www.oracle.com/technetwork/documentation/oracle-retail-100266.html>

(Data Model documents are not available through Oracle Technology Network. You can obtain these documents through My Oracle Support.)

# Conventions

The following text conventions are used in this document:

<b>Convention</b>	<b>Meaning</b>
<b>boldface</b>	Boldface type indicates graphical user interface elements associated with an action, or terms defined in text or the glossary.
<i>italic</i>	Italic type indicates book titles, emphasis, or placeholder variables for which you supply particular values.
monospace	Monospace type indicates commands within a paragraph, URLs, code in examples, text that appears on the screen, or text that you enter.



---

---

# Security Features

Oracle Retail AI Foundation Cloud Services uses web services to push information to Customer Engagement and to expose configuration as well as application incremental data and reports to customers.

## Technology-Specific Guidelines

This section details the security guidelines.

### Security Features

Oracle Retail AI Foundation Cloud Services supports the following security features.

#### Web Services

The Web service in Oracle Retail AI Foundation Cloud Services is stateless, so state is not stored or managed. Pagination such as the batch size of data and parameters such as export data time, product, location, and so on are used to manage payload size and to handle session timeouts.

#### SOAP

Oracle Retail AI Foundation Cloud Services has an Outbound Interface to push Customer Segment and its members to ORCE (Customer Engagement). This interface supports the following security features.

- Message authentication is enabled in ORCE, and the Oracle Retail AI Foundation Cloud Services message includes authentication information in the HTTP header for the message. This authentication information is specific to ORCE and is stored in the Credential Stores. The Credential Stores are created or updated from the Data Management task, enabled for an Administrator. The Base64 encoding tool is used to encode the authorization key that is sent as part of the Message HTTP Header request. The Credential Stores use APIs that applications can use to create, read, update, and manage credentials securely and mark code as being "privileged", thus affecting subsequent access determinations.
- Oracle Retail AI Foundation Cloud Services provides configuration to set up proxy settings for both HTTP and HTTPS.
- XML sent as part of the message relies on marshalling and un-marshalling to and from Java Objects generated using the WSDL/Schema exposed via ORCE. This enforces XML generated is well formed and valid. It is the responsibility of ORCE to convert XML; Oracle Retail AI Foundation Cloud Services does not perform any XML Conversion. There are no concerns regarding XXE and XEE.

**REST**

Oracle Retail AI Foundation Cloud Services has an Outbound Interface to export data (GET request), and it use REST to expose data. These web services are REST-based; it is assumed that callers are familiar with the basic REST principles (such as the usage of HTTP verbs). AC and ASO export web services can serve as a means of obtaining incremental update data from a specified point in time. All services support the query parameter contentType and the HTTP header Content-Type, with supported values application/json and application/xml. The query parameter takes precedence; if no content type is supplied, then application/json serves as the default. Basic authentication is used, so you may use any client software that supports it. Authorization is done for ADF-LDAP (OID) mapped roles, and only administrator roles are used. (That is, the calling user must be in a duty that is mapped to the defined administrator roles.) JSON/XML parsing is done using standard JAXB request parameters that are validated before data is fetched.

**Authentication and Authorization**

For authorization, Oracle Retail AI Foundation cloud Services modules have been built with role-based access. Access to application user interface components is done by assigning application roles. Application roles are defined as part of the application and deployed as part of the installation process. Application roles are mapped to enterprise roles during the initial environment provisioning. Enterprise roles exist as LDAP groups in OID. For Oracle Identity Cloud Service (IDCS) and Oracle Cloud Infrastructure Identity and Access Management (OCI IAM) users, it is available in the import file. Refer to the *Oracle Retail AI Foundation Cloud Services User Guide* for the definition of standard user roles.

**User Roles**

Oracle Retail AI Foundation Cloud Services supports the following roles.

**Table 1–1 User Roles**

Job Role	Role Description
<b>AIF Platform</b>	
ADMINISTRATOR_JOB	A user who understands all the parameters driving the application and is responsible for their configuration as well as managing the credential store for CE, RPM, and so on.
ANALYTIC_EXPERT_JOB	Responsible for understanding the retailer's business, has some business analytics training, and has been trained in the use of the CDT and DT applications.
ASSORTMENT_PLANNER_JOB	The Assortment Planner is responsible for creating the category assortments, to meet the roles, strategies, and tactics set for the category by the Category Manager. Multiple category assortments are created, for each cluster or store. One planner can be responsible for multiple categories.
CLUSTERING_ADMINISTRATOR_JOB	Responsible for planning, building, and analyzing store clusters based on a variety of store and category attributes to support assortment, pricing, and space planning business processes in the Store Clustering Module.
CUSTOMER_ANALYST_JOB	Develops customer segments and analyzes their customer shopping and buying behavior to determine customer differentiation, trends, and opportunities in Customer Segmentation Module.
CUSTOMER_SEGMENT_ADMINISTRATOR_JOB	Responsible for analytical defaults and configuration, testing, and model diagnosis. This includes Filter, Sampling and Attribute Mining in the Customer Segmentation Module.
DATA_LAKE_HUE_ANALYST_JOB	Analyst role for accessing data lake.
DATA_LAKE_HUE_ADMIN_JOB	Administrator role for accessing data lake.

**Table 1–1 (Cont.) User Roles**

<b>Job Role</b>	<b>Role Description</b>
FORECAST_ANALYST_JOB	Reviews and approves forecasts on a day-to-day basis. An advanced forecast analyst may also be responsible for forecast parameter maintenance and demand modeling activities.
HOS_FORECAST_ANALYST_JOB	A user who understands the restaurant's business, has some business analytics training, and has been trained in the use of the Forecasting application.
HOS_FORECAST_CORPORATE_ANALYST_JOB	Responsible for ensuring the efficient running and profitability of multiple stores in a restaurant chain. This user works with the store manager to review and override the daily sales forecasts, as needed.
HOS_FORECAST_STORE_MANAGER_JOB	Responsible for overseeing stock levels and ordering supplies to meet a restaurant's profitability and quality goals. This user reviews, overrides, and approves the daily sales forecast of menu item groups. The store manager is typically responsible for one store.
MARKET_ANALYST_JOB	Reviews customer segments with business experts, suited (distinctly) for targeted promotion, category and assortment planning, targeted pricing, customer, and market basket analytics in Customer Segmentation module.
MARKET_BASKET_ANALYSIS_JOB	A user who understands the retailer's business, has some business analytics training, and is responsible for reviewing sales transaction affinity analysis.
MERCHANDISER_JOB	A Store Merchandiser (or In-Store Merchandiser) is an hourly employee who executes the placement and assembly of retail fixtures, adjustment of shelves and arrangement and placement of product on the shelves in accordance with CAD drawings and planograms.
ORCL_ADMIN_JOB	Oracle Cloud Administration role for a retailer using Innovation Workbench using APEX Workspace.
RETURN_LOGISTICS_JOB	A user who is familiar with the retailer's product categories and has been trained in the use of the AE application.
SIZE_PROFILE_ANALYST_JOB	Responsible for system parameter maintenance to support size profile calculations. May also be responsible for approval of size profiles. A user who understands size and profile estimations and is able to review and submit them for the retailer's business.
SIZE_PROFILE_OPT_JOB	A user who understands size and profile estimations and is able to review and submit them for the retailer's business.
SOCIAL_ANALYTICS_JOB	A user who understands the retailer's business, has some business analytics training, and has been trained in the use of the Social Analytics application.
ATTRIBUTE_EXTRACTION_JOB	A user who is familiar with the retailer's product categories and has been trained in the use of the Attribute Extraction.
ATTRIBUTE_BINNING_JOB	A user who understands the retailer's business, has some business analytics training, and has been trained in the use of the CDT application and attribute binning application.
MENU_RECOMMENDATION_JOB	A user who understands the restaurant's business, has some business analytics training, and has been trained in the use of the Menu Recommendation.
DATA_SCIENCE_ANALYST_JOB	Data Science Analyst role for a retailer using Innovation Workbench using APEX Workspace
DATA_SCIENCE_ADMINISTRATOR_JOB	Data Science Administration role for retailer using Innovation Workbench using APEX Workspace
DATA_SCIENCE_ORCL_ADMIN_JOB	Data Science Cloud Administration role for a retailer using Innovation Workbench using APEX Workspace
DATA_SCIENCE_OLDS_ADMIN_JOB	Role to enable the administration of python notebook service under Innovation Workbench
DATA_SCIENCE_OLDS_ANALYST_JOB	Role to enable the Python notebook for an analyst under Innovation Workbench.
POSLOGS_SERVICE_JOB	Point of Sales broadcast listener role to enable integration between AIF and Oracle XStore.

**Table 1–1 (Cont.) User Roles**

<b>Job Role</b>	<b>Role Description</b>
PLATFORM_SERVICES_ADMINISTRATOR_ABSTRACT	Platform Services role required for accessing services.
<b>Assortment Space Optimization</b>	
CATEGORY_MANAGER_JOB	Product-assortment-centric user who is interested in viewing ASO results and in the translation of data between CMPO, Retail Analytics, and ASO.
SPACE_PLANNER_JOB	A Store Planner is a corporate employee with responsibility for designing the layout of floor plans, department sizes and locations, the layout of fixtures and aisles, applying health, safety and welfare guidelines, and managing and publishing floor-plan versions. This user is also responsible for the day-to-day micro-space optimization activities.
MERCHANDISING_ANALYST_JOB	Main business user responsible for day-to-day micro-space optimization activities
SPACE_ADMINISTRATOR_JOB	Responsible for general system setup and configuration tasks related to the business
FORECAST_MANAGER_JOB	Responsible for analytical configuration, testing, and model diagnosis.
<b>Promotions and Markdowns Optimization</b>	
BUYER_JOB	Responsible for a department or departments and makes the budget decisions for pricing recommendations. Approves or rejects an OO run. Responsible for the translation of data between OO and Oracle Retail Price Management (RPM) and Oracle Retail Customer Engagement (CE).
PRICING_ANALYST_JOB	Main business user responsible for day-to-day pricing optimization activities (e.g., creating scenarios).
PRICING_MANAGER_JOB	Responsible for analytical configuration, testing, and model diagnosis. Oversees the work done by the pricing analyst.
PRICING_ADMINISTRATOR_JOB	Responsible for the general system setup and configuration tasks related to the business.
<b>Offer Optimization</b>	
CHATBOT_QNA_VIEW_JOB	Conversational AI role to enable frequently asked question types of bot conversation.
CHATBOT_SERVICE_JOB	Conversational AI role to enable integration between AIF and Oracle Chatbot.
CHATBOT_VIEW_JOB	Conversational AI role to enable real time bot conversations.
TARGETED_OFFER_JOB	User who probably works in the marketing department and who is responsible for accepting or rejecting targeted offers that are sent out to customers.
<b>Inventory Optimization</b>	
INVENTORY_ANALYST_JOB	Works closely with the buyer to ensure product distribution aligns to strategy. Main business user responsible for day-to-day inventory optimization activities (e.g., reviewing strategies, recommendations, and so on).

Note that in stage and pre-production environments, users are assigned roles that are appended with `_PREPROD`.

## Oracle Retail AI Foundation Cloud Services/ORDS Integration

This section provides security details regarding ORDS/(APEX) integration with Oracle Retail AI Foundation Cloud Services. The following three security features are provided:



- **Single Sign On (SSO).** AIFF integration with ORDS supports SSO, using ORDS-provided authentication schemes called the HTTP Header Variable. User credential verification is performed by IDCS or OCI IAM, which passes the user's name to Oracle Application Express using a HTTP header variable such as IDCS\_REMOTE\_USER. While setting up the scheme in ORDS, the logout URL is also configured.
- **Schema used in the ORDS Workspace.** Oracle Retail AI Foundation Cloud Services integration with ORDS includes defining a new schema called Retail Workspace Schema in the ORDS workspace. This is provided to the retailer, and in turn is associated with the AIF product schema. Any database objects shared with the Retail Workspace Schema have read-only privileges.
- **Declarative REST API.** Oracle Retail AI Foundation Cloud Services integration with ORDS also provides the retailer with a declarative way to create new service endpoints in the system. Access to such endpoints are enabled via OAuth2.0. This REST API request is authorized using the IDCS or OCI IAM client credential grants type, where the retailer requests an access code from IDCS or OCI IAM and passes the token in subsequent calls to access data.

Figure 1-1 Network Diagram

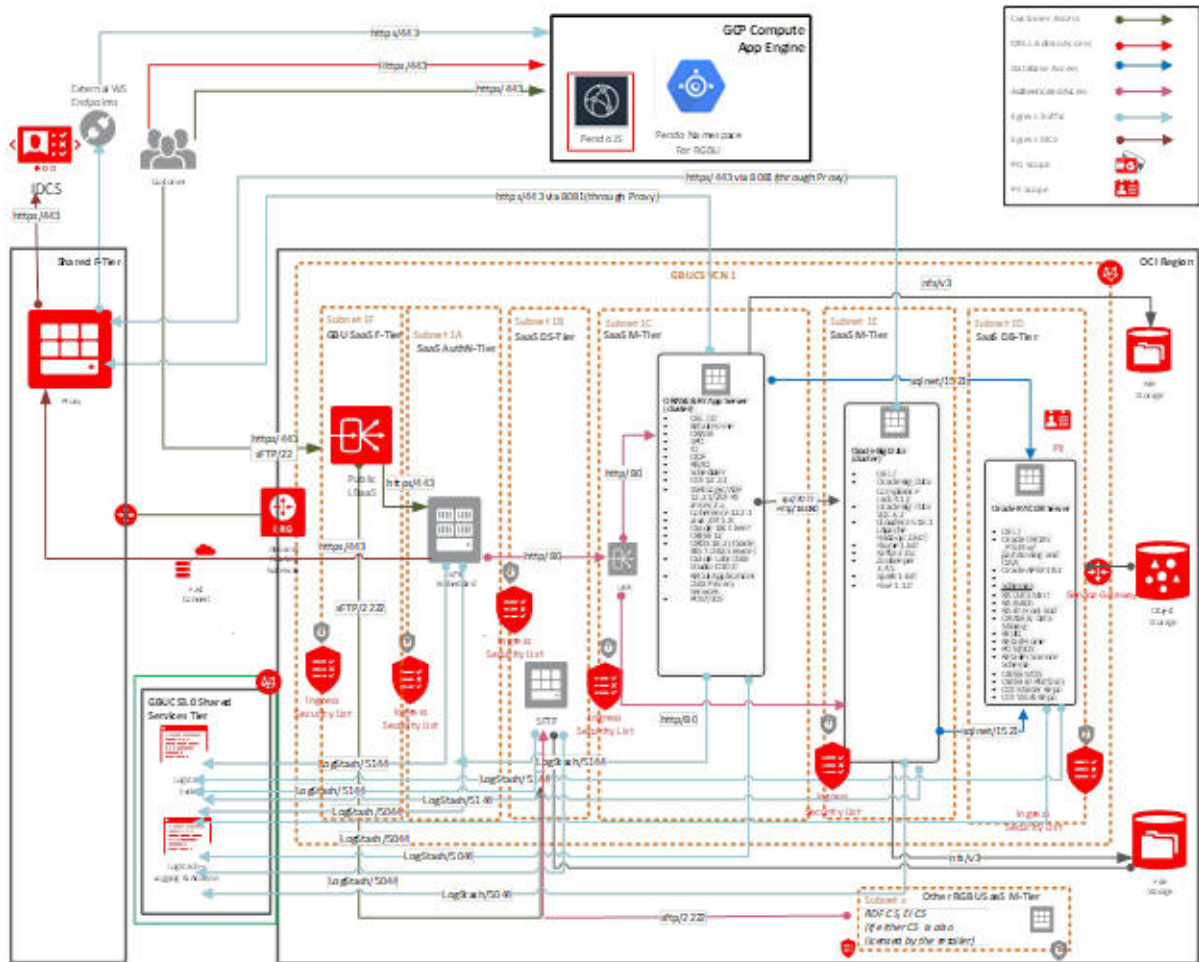



---

---

## Responsibilities

As retailers migrate to the cloud, they must consider how the cloud, and more specifically SaaS, will impact their privacy, security, and compliance efforts. As the cloud service provider, Oracle Retail AI Foundation Cloud Services works together with customers to meet cloud security objectives.

### Retailer Responsibilities

At a high level, retailers are responsible for:

- Understanding Oracle's security policies
- Implementing their own corporate policies via Oracle tools
- Creating and administering users via Oracle tools
- Ensuring data quality and enforcing end-user devices security controls, so that antivirus, malware and other malicious code checks are performed on data and files before uploading data
- Ensuring that end-user devices meet the minimum security requirements
- Generating public/private key pairs as requested by Oracle Retail AI Foundation Cloud Services

To securely implement Oracle Retail AI Foundation Cloud Services, retailers and their implementation partners should read this document to understand Oracle's security policies. This document summarizes information and contains links to many other Oracle documents.

### Oracle Responsibilities

As the cloud service provider, at the highest level Oracle Retail AI Foundation Cloud Services is responsible for:

- building secure software
- provisioning and managing secure environments
- protecting the retailer's data

Oracle Retail AI Foundation Cloud Services fulfills its responsibilities by a combination of corporate level development practices and cloud delivery policies. Sections in this document will describe this information in great detail later in this document.



---

---

# Oracle Retail AI Foundation Cloud Services SaaS Security

Security is a many faceted issue to address. To discuss Oracle Retail AI Foundation Cloud Services SaaS security, it helps to define and categorize the many aspects of security. For the purposes of this document, we discuss the following categories of SaaS security:

- Secure Product Engineering
- Secure Deployment
- Secure Management
- Assessment and Audits

## Secure Product Engineering

Oracle builds secure software through a rigorous set of formal, always evolving security standards and practices known as Oracle Software Security Assurance (OSSA). OSSA encompasses every phase of the product development lifecycle.

More information about OSSA can be found at:

<https://www.oracle.com/corporate/security-practices/assurance/>

The cornerstones of OSSA are Secure Coding Standards and Security Analysis and Testing.

Secure Coding Standards include both general use cases and language specific security practices. More information about these practices can be found at:

<https://www.oracle.com/corporate/security-practices/assurance/development/>

Security Analysis and Testing includes product specific functional security testing and both static and dynamic analysis of the code base. Static Analysis is performed via tools including both internal Oracle tools and HP's Fortify. Dynamic Analysis focuses on APIs and endpoints, using techniques like fuzzing to test interfaces and protocols.

<https://www.oracle.com/corporate/security-practices/assurance/development/analysis-testing.html>

Specific security details of the Oracle Retail AI Foundation Cloud Services are discussed in detail later in this document.

## Secure Deployment

Secure deployment refers to the security of the infrastructure used to deploy the SaaS application. Key issues in secure deployment include Physical Safeguards, Network Security, Infrastructure Security and Data Security.

## Physical Safeguards

Oracle Retail AI foundation Cloud Services SaaS applications are deployed via Oracle Cloud Infrastructure datacenters. Access to Oracle Cloud data centers requires special authorization that is monitored and audited. The premises are monitored by CCTV, with entrances protected by physical barriers and security guards. Governance controls are in place to minimize the resources that are able to access systems. Physical security safeguards are further detailed in Oracle's Cloud Hosting and Delivery Policies.

<http://www.oracle.com/us/corporate/contracts/ocloud-hosting-delivery-policies-3089853.pdf>

## Network Security

The Oracle Cloud network is isolated from the Oracle Corporate Network. Customer instances are separated down to the VLAN level.

## Infrastructure Security

The security of the underlying infrastructure used to deploy Oracle Retail AI Foundation Cloud Services SaaS is regularly hardened. Critical patch updates are applied on a regular schedule. Oracle maintains a running list of critical patch updates and security alerts. Per Oracle's Cloud Hosting and Delivery Policies, these updates are applied to all Oracle SaaS systems.

<https://www.oracle.com/technetwork/topics/security/alerts-086861.html>

Before Oracle Retail AI Foundation Cloud Services deploys code to SaaS, Oracle's Global Information Security team performs penetration testing on the cloud service. This penetration testing and remediation prevents software or infrastructure issues in production systems.

<https://www.oracle.com/corporate/security-practices/assurance/development/ethical-hacking.html>

## Data Security

Oracle Retail AI Foundation Cloud Services uses a number of strategies and policies to ensure the retailer's data is fully secured.

- Data Design - Oracle Retail AI Foundation Cloud Services applications avoid storing personal data. Where PII data exists in a system, Data Minimization, Right to Access and Right to Forget services exist to support data privacy standards.
- Storage - Oracle Retail AI Foundation cloud Services applications use encrypted tablespaces to store sensitive data.
- Transit - All data is encrypted in transit, Retail SaaS uses TLS for secure transport of data, as documented in Oracle's Cloud Hosting and Delivery policy.

<https://www.oracle.com/assets/ocloud-hosting-delivery-policies-3089853.pdf>

- Oracle Retail AI Foundation Cloud Services also implements data filtering so that users see the data stripes relevant to their own jobs.

## Secure Management

Oracle Retail AI Foundation Cloud Services manages SaaS based on a well documented set of security-focused Standard Operating Procedures (SOPs). The SOPs provide direction and describe activities and tasks undertaken by Oracle personnel when delivering services to customers. SOPs are managed centrally and are available to authorized personnel through Oracle's intranet on a need-to-know basis.

All network devices, servers, OS, applications and databases underlying Oracle Retail AI Foundation Cloud Services are configured and maintain auditing and logging. All logs are forwarded to a Security Information and Event Management (SIEM) system. The SIEM is managed by the Security Engineering team and is monitored 24\*7 by the GBU Security Operations team. The SIEM is configured to alert the GBU Security Operations team regarding any conditions deemed to be potentially suspicious, for further investigation. Access given to review logs is restricted to a subset of security administrators and security operations personnel only.

## **Assessment and Audit**

Oracle Cloud meets all ISO/IEC 27002 Codes of Practice for Information Security Controls. Third Party Audit Reports and letters of compliance for Oracle Cloud Services are periodically published.

