

Oracle® Revenue Management and Billing  
Version 2.8.0.0.0

## Insurance User Guide

Revision 9.19

F17813-01

June, 2019

**ORACLE®**



---

---

# Notices

---

Oracle Revenue Management and Billing Version 2.8.0.0.0 Insurance User Guide

F17813-01

## **Copyright Notice**

Copyright © 2019, Oracle and/or its affiliates. All rights reserved.

## **Trademark Notice**

Oracle, Java, JD Edwards, PeopleSoft, and Siebel are registered trademarks of Oracle Corporation and/or its affiliates. Other names may be trademarks of their respective owners.

Intel and Intel Xeon are trademarks or registered trademarks of Intel Corporation. All SPARC trademarks are used under license and are trademarks or registered trademarks of SPARC International, Inc. AMD, Opteron, the AMD logo, and the AMD Opteron logo are trademarks or registered trademarks of Advanced Micro Devices. UNIX is a registered trademark of The Open Group.

## **License Restrictions Warranty/Consequential Damages Disclaimer**

This software and related documentation are provided under a license agreement containing restrictions on use and disclosure, and are protected by intellectual property laws. Except as expressly permitted in your license agreement or allowed by law, you may not use, copy, reproduce, translate, broadcast, modify, license, transmit, distribute, exhibit, perform, publish, or display any part, in any form, or by any means. Reverse engineering, disassembly, or de-compilation of this software, unless required by law for interoperability, is prohibited.

## **Warranty Disclaimer**

The information contained herein is subject to change without notice and is not warranted to be error-free. If you find any errors, please report them to us in writing.

## **Restricted Rights Notice**

If this software or related documentation is delivered to the U.S. Government or anyone licensing it on behalf of the U.S. Government, the following notice is applicable:

## **U.S. GOVERNMENT RIGHTS**

Oracle programs, including any operating system, integrated software, any programs installed on the hardware, documentation, and/or technical data delivered to U.S. Government end users are “commercial computer software” or “commercial technical data” pursuant to the applicable Federal Acquisition Regulation and agency-specific supplemental regulations. As such, use, duplication, disclosure, modification, and adaptation of the programs, including any operating system, integrated software, any programs installed on the hardware, documentation, and/or technical data shall be subject to license terms and restrictions as mentioned in Oracle License Agreement, and to the extent applicable, the additional rights set forth in FAR 52.227-19, Commercial Computer Software--Restricted Rights (June 1987). No other rights are granted to the U.S. Government.

## **Hazardous Applications Notice**

This software is developed for general use in a variety of information management applications. It is not developed or intended for use in any inherently dangerous applications, including applications that may create a risk of personal injury. If you use this software in dangerous applications, then you shall be responsible to take all appropriate fail-safe, backup, redundancy, and other measures to ensure the safe use of this software. Oracle Corporation and its affiliates disclaim any liability for any damages caused by use of this software in dangerous applications.

## **Third Party Content, Products, and Services Disclaimer**

This software and documentation may provide access to or information on content, products, and services from third parties. Oracle Corporation and its affiliates are not responsible for and expressly disclaim all warranties of any kind with respect to third party content, products, and services unless otherwise set forth in an applicable agreement between you and Oracle. Oracle Corporation and its affiliates will not be responsible for any loss, costs, or damages incurred due to your access to or use of third party content, products, or services.

# Contents

<b>About this Document.....</b>	<b>45</b>
Intended Audience.....	45
Organization of the Document.....	45
Conventions.....	49
Related Documents.....	49
Change Log.....	50
<b>Chapter I: Self-Funded Customer Management.....</b>	<b>53</b>
Self-Funded Entities.....	54
Parent Customer.....	54
Bill Groups.....	55
Bill Group's Account.....	55
Self-Funded Policy.....	56
Price Items.....	56
Pricing Rule Types.....	56
Pricing Rules.....	57
Price Assignments.....	58
<b>Chapter II: Fully-Insured Customer Management.....</b>	<b>59</b>
Fully-Insured Entities.....	60
Parent Customer.....	61
Bill Groups.....	61
Bill Group's Account.....	61
Fully-Insured Policy.....	62
Policy Plans.....	62
Price Items.....	63
Pricing Rule Types.....	63
Pricing Rules.....	63
Price Assignments.....	63
<b>Chapter III: Customer Registration.....</b>	<b>65</b>
Customer Registration (Without Approval) Status Transition.....	69
Customer Registration (With Approval) Status Transition.....	69
Customer Registration Template.....	71
Search Customer Registration Template.....	72
Customer Registration Template.....	75
Searching for a Customer Registration Template.....	76
Viewing the Customer Registration Template Details.....	77
Defining a Customer Registration Template.....	77
Editing a Customer Registration Template.....	81
Copying a Customer Registration Template.....	84
Deleting a Customer Registration Template.....	87
Customer Registration Type.....	88
Customer Registration Type List.....	88
Customer Registration Type.....	89
Searching for a Customer Registration Type.....	93
Defining a Customer Registration Type.....	94
Defining an Additional Data for a Customer Registration Type.....	96

Defining a Characteristic for a Customer Registration Type.....	99
Adding a Template in a Customer Registration Type.....	100
Configuring Attributes to Copy Customer Registration Type.....	101
Editing a Customer Registration Type.....	104
Copying a Customer Registration Type.....	106
Deleting a Customer Registration Type.....	107
Viewing the Customer Registration Type Details.....	108
Customer Registration (Used for Searching).....	108
Search Customer Registration.....	109
Searching a Customer Registration.....	117
Viewing the Customer Registration Details.....	118
Defining a Customer Registration.....	119
Adding the Names of a Person.....	121
Adding the Phone Details of a Person.....	122
Adding the Identifier Details of an Account.....	123
Adding the Contact Details of a Person.....	124
Defining a Characteristic for a Person.....	125
Defining a Person to Person Relationship.....	126
Defining a Characteristic for a Person to Person Relationship.....	127
Adding an Account for a Person.....	128
Adding the Identifier Details of an Account.....	130
Adding Automatic Payment Details of an Account.....	131
Associating a Person to an Account.....	132
Adding Bill Routing Information for an Account.....	134
Defining a Characteristic for an Account.....	134
Defining a Policy.....	135
Associating a Person to Policy.....	137
Defining a Characteristic for a Policy.....	138
Adding a Plan in Policy.....	139
Associating a Pricing Rule Type with a Policy Plan.....	141
Defining a Characteristic for a Policy Plan.....	142
Defining a Characteristic for Customer Registration.....	144
Viewing the Details of an Account.....	145
Editing the Account Details of a Person.....	145
Copying a Customer Registration.....	147
Viewing the Details of a Policy.....	150
Editing the Policy Details.....	150
Viewing the Details of a Policy Plan.....	152
Editing the Policy Plan Details.....	152
Customer Registration (Used for Viewing).....	154
Customer Registration - Main.....	155
Customer Registration.....	155
Account Information.....	155
Policies.....	158
Parent Policies.....	158
Customer Registration - Account.....	159
Account Information.....	159
Customer Registration - Policy.....	162
Policy Information.....	162
Plans.....	163
Customer Registration - Plan.....	164
Plan Information.....	164
Customer Registration - Log.....	165
Customer Registration Log.....	165
Editing the Customer Registration Details.....	166
Submitting a Customer Registration.....	168

Approving a Customer Registration.....	168
Rejecting a Customer Registration.....	169
Requesting to Resubmit a Customer Registration for Approval.....	171
Viewing the Log of a Customer Registration.....	172
Adding a Log Entry for a Customer Registration.....	173

## **Chapter IV: Customer 360° View.....175**

Prerequisites.....	177
Customer 360° View.....	177
360° Search.....	177
Searching for a Person.....	185
Searching for an Account.....	186
Searching for a Policy.....	187
Viewing the 360° Information of a Person.....	188
Viewing the 360° Information of an Account.....	190
Viewing the 360° Information of a Policy.....	191
Viewing the Pricing Information of a Parent Customer.....	192
Viewing the Pricing Information of a Bill Group.....	194
Customer 360° Information.....	196
Customer 360° Information - Person.....	201
Person Information.....	202
Person Characteristics.....	203
Child Persons.....	204
Person Hierarchy.....	204
Person Billing Hierarchy.....	205
Bill Group Derivation and Pricing Parameters.....	208
Bill Group Sorting.....	210
Customer Contacts.....	211
Bill Groups Created Via Customer Registration.....	212
Customer 360° Information - Account.....	212
Account List.....	213
Account Information.....	214
Account Characteristics.....	216
Administrative Contracts.....	216
Auto Pay Details.....	217
Account Financial and Collections Summary.....	217
Billing and Adjustment Summary.....	218
Open Bills.....	219
Billed Vs Paid.....	220
Timeline.....	223
Customer 360° Information - Policy.....	225
Policy List.....	226
Policy Information.....	227
Policy Persons.....	228
Policy Plans.....	228
Customer 360° Information - Pricing.....	229
Parent Customer Pricing Rules.....	231
Bill Group ASO Policy Pricing Rule Summary.....	234
Parent Customer Pricing Rule Summary.....	235
Bill Group ASO Policy Information.....	236
Bill Group ASO Policy Pricing Rules.....	237
Bill Group Pricing Groups.....	242
Pricing Rule Approval Transactions.....	243
Policy Plan Pricing Rule Summary.....	244
Policy Plan Information.....	245

Policy Plan Pricing Rules.....	246
Defining a Sort ID for a Bill Group.....	247
Editing a Sort ID of a Bill Group.....	248
Deleting a Sort ID of a Bill Group.....	249
Creating a Bill Group Sorting Upload Request.....	250
Defining the Derivation and Pricing Parameters for a Bill Group and Sort ID Combination.....	252
Editing the Derivation and Pricing Parameters of a Bill Group and Sort ID Combination..	255
Creating a Bill Group Derivation and Pricing Parameters Upload Request.....	256
Viewing the Pricing Rules Defined for a Policy of a Bill Group.....	258
Viewing the Pricing Groups of a Bill Group.....	259
Renewing a Self-Funded Policy of a Bill Group.....	260
Viewing the Bill Details.....	262
Viewing the Pricing Rules Defined for a Policy Plan.....	263
Bill Information.....	264
Bill Information.....	265
Adjustments.....	265
Settlement Activities.....	265
Bill Segment Summary.....	266
Bill Segment Details.....	266
Hold Details.....	267
Offset Details.....	268
Refund and Write Off Details.....	268

## **Chapter V: Pricing Management.....271**

Types of Pricing.....	273
Multi Parameter Based Pricing.....	273
Price Assignment Search Mechanism.....	277
Person Relationship Type Sequence.....	279
Pricing Eligibility.....	281
Persisting Interest Rate for Rate Type Price Items.....	282
Persisting Fee for Fee Type Price Items.....	283
Repricing.....	283
Two-Dimensional Pricing.....	288
Types of Price Item Bundle.....	288
Regular Bundle.....	288
Ratio Bundle.....	290
Phantom Bundle.....	292
Parameter.....	294
Parameter (Used for Searching).....	294
Search Parameter.....	294
Searching for a Parameter.....	297
Defining a Parameter.....	297
Editing a Parameter.....	303
Deleting a Parameter.....	309
Copying a Parameter.....	310
Viewing the Parameter Details.....	315
Parameter (Used for Viewing).....	316
Parameter.....	316
Price Item.....	318
Price Item (Used for Searching).....	319
Search Price Item.....	319
Searching for a Price Item or Price Item Bundle.....	322
Defining a Price Item or Price Item Bundle.....	322
Associating a Parameter with a Price Item or Price Item Bundle.....	326



Defining Valid Predefined Parameter Values for a Price Item or Price Item Bundle.....	328
Associating a Price Item or Price Item Bundle with a Division.....	329
Defining Division-Specific SQIs for a Price Item or Price Item Bundle.....	330
Defining Division-Specific Characteristics for a Price Item or Price Item Bundle..	331
Defining Division-Specific Accrual Type Criteria for a Price Item or Price Item Bundle.....	333
Defining a Characteristic for a Price Item or Price Item Bundle.....	334
Copying a Price Item or Price Item Bundle.....	335
Viewing the Price Item or Price Item Bundle Details.....	338
Price Item (Used for Viewing).....	339
Price Item.....	340
Parameters.....	342
Predefined Parameter Values for Price Item.....	342
Divisions.....	343
Division-Specific SQIs for Price Item.....	343
Division-Specific Characteristics for Price Item.....	344
Division-Specific Accrual Type Criteria for Price Item.....	344
Price Item Relationship.....	345
Editing a Price Item or Price Item Bundle.....	346
Price Item Relationship.....	349
Assigned Price Items.....	350
Viewing the Price Items or Price Item Bundles Associated with a Parent Price Item.....	353
Viewing the Price Items or Price Item Bundles Added to a Price Item Bundle.....	353
Associating a Price Item or Price Item Bundle with a Parent Price Item.....	353
Adding a Price Item or Price Item Bundle to a Price Item Bundle.....	356
Setting the Parameters for a Price Item or Price Item Bundle.....	358
Defining Relationship-Specific Characteristics for a Price Item or Price Item Bundle.....	360
Disassociating a Price Item or Price Item Bundle from a Parent Price Item.....	361
Removing a Price Item or Price Item Bundle from a Price Item Bundle.....	362
Filtering the Price Items or Price Item Bundles Associated with a Parent Price Item.....	362
Filtering the Price Items or Price Item Bundles Added to a Price Item Bundle.....	363
Price Item Assignments.....	364
Active Price Lists where Price Item is Assigned.....	364
Persons to whom Price Item is Assigned.....	364
Accounts where Price Item is Assigned.....	365
Viewing the Price Lists, Persons, or Accounts where a Price Item is Assigned.....	365
Price List.....	366
Price List (Used for Searching).....	367
Search Price List.....	367
Price List Price Items.....	370
Searching for a Price List.....	371
Viewing Price Items Assigned to a Price List.....	372
Defining a Price List.....	373
Defining the Price List Hierarchy.....	375
Defining a Characteristic for a Price List.....	376
Associating a Price List with a Division.....	378
Defining Eligibility Criteria for a Price List.....	378
Copying a Price List.....	380
Viewing the Price List Details.....	381
Price List (Used for Viewing).....	382
Price List.....	382
Eligibility Criteria.....	384

Editing a Price List.....	385
Price List Price Item Pricing.....	387
Price List Price Items.....	388
Search Price Item.....	389
Viewing Price Items Assigned to a Price List.....	394
Removing a Price Item from a Price List.....	395
Viewing a Price Item Pricing.....	395
Editing a Price Item Pricing of a Price List.....	397
Assigning a Price Item to a Price List.....	401
Defining Characteristics for a Price Item Pricing.....	405
Defining Parameters for a Price Item Pricing.....	406
Defining TFM Information in a Price Item Pricing.....	407
Price List Assignment.....	409
Price List Assignments.....	409
Price List Price Items.....	411
Search Price List for Assignment.....	412
Viewing Price Lists Assigned to an Account.....	415
Viewing Price Lists Assigned to a Person.....	416
Viewing Price Items Assigned to a Price List.....	417
Assigning a Price List to an Account.....	418
Assigning a Price List to a Person.....	421
Defining Characteristics for a Price List Assignment.....	424
Editing the Price List Assignment Details of an Account.....	425
Editing the Price List Assignment Details of a Person.....	428
Price List Assignments.....	431
Accounts where Price List is Assigned.....	431
Persons to whom Price List is Assigned.....	432
Viewing Accounts and Persons where Price List is Assigned.....	433
Persons and Accounts Eligible for Price List Assignment.....	433
Eligible Accounts.....	434
Eligible Persons.....	434
Assigning a Price List to One or More Eligible Accounts.....	435
Assigning a Price List to One or More Eligible Persons.....	437
Defining Characteristics for a Price List Assignment.....	438
Pricing (Account).....	439
Effective Price Assignments for Account.....	440
Search Price Item.....	445
Viewing Effective Price Assignments of an Account.....	450
Filtering Effective Price Assignments of an Account.....	451
Exporting Effective Price Assignments of an Account.....	452
Copying a Price Item Pricing.....	455
Viewing a Price Item Pricing.....	456
Editing a Price Item Pricing of an Account.....	458
Overriding a Price Item Pricing of an Account.....	462
Assigning a Price Item to an Account.....	466
Defining Characteristics for a Price Item Pricing.....	470
Defining Parameters for a Price Item Pricing.....	471
Defining TFM Information in a Price Item Pricing.....	472
Pricing (Person).....	473
Effective Price Assignments for Person.....	474
Search Price Item.....	479
Viewing Effective Price Assignments of a Person.....	484
Filtering Effective Price Assignments of a Person.....	485
Exporting Effective Price Assignments of a Person.....	486
Copying a Price Item Pricing.....	489
Viewing a Price Item Pricing.....	490

Editing a Price Item Pricing of a Person.....	492
Overriding a Price Item Pricing of a Person.....	496
Assigning a Price Item to a Person.....	500
Defining Characteristics for a Price Item Pricing.....	504
Defining Parameters for a Price Item Pricing.....	505
Defining TFM Information in a Price Item Pricing.....	506
Price Item Pricing (Used for Viewing).....	507
Price Item Pricing.....	508
Rate and Price Component Summary.....	511
Rate Components.....	512
Price Components.....	512
Tiering Criteria.....	514
Pricing Eligibility Criteria.....	514
Two-Dimensional Pricing.....	516
Defining a Price Item Pricing.....	516
Viewing the Price Components of a Rate Component.....	519
Viewing the Tiering Criteria of a Price Component.....	520
Viewing the Pricing Eligibility Criteria of a Price Component.....	522
Defining a Price Component for a Rate Component.....	524
Defining a Tiering Criteria for a Price Component.....	527
Defining a Pricing Eligibility Criteria for a Price Component.....	530
Editing a Price Component.....	534
Deleting a Price Component.....	537
Editing a Tiering Criteria of a Price Component.....	540
Deleting a Tiering Criteria of a Price Component.....	544
Editing a Pricing Eligibility Criteria of a Price Component.....	547
Deleting a Pricing Eligibility Criteria of a Price Component.....	554
Deleting a Price Item Pricing.....	557
Editing a Price Item Pricing.....	560
Submitting a Price Item Pricing.....	566
Overriding a Price Item Pricing.....	569
Editing the Two-Dimensional Pricing.....	570
Pricing Simulation.....	572
Search Pricing.....	572
Simulation - Effective Pricing Information.....	576
Searching Pricing Simulation for Account or Price List.....	581
Viewing Pricing Simulation.....	582
Exporting Effective Price Simulation.....	583
Eligible Price List.....	585
Search Eligible Price Lists.....	585
Rate Definition.....	587
Rate Schedule Components.....	588
Create/Edit Rate Definition.....	589
Defining Tiering Setup of a Rate Component.....	590
Editing Tiering Setup of a Rate Component.....	591
Deleting Tiering Setup of a Rate Component.....	592
Tiering Criterion.....	592
Tiering Criterion List.....	593
Edit Tiering Criterion.....	593
Create Tiering Criterion.....	594
Creating a Tiering Criterion.....	594
Editing a Tiering Criterion.....	595
Variance Parameter.....	595
Filtering the Variance Parameters.....	595
Defining a Variance Parameter.....	596
Editing a Variance Parameter.....	597

Deleting a Variance Parameter.....	597
Person to Person Relationship Type Sequence.....	598
Search Person Relationship Type Sequence for Price Item.....	599
Search Person Relationship Type Sequence for Division.....	600
Searching Relationship Type Sequence for a Division, Price Item, and Price Item Parameters.....	601
Defining Relationship Type Sequence for a Division, Price Item, and Price Item Parameters.....	602
Editing Relationship Type Sequence of a Division, Price Item, and Price Item Parameters.....	603
Deleting Relationship Type Sequence of a Division, Price Item, and Price Item Parameters.....	605
Viewing Relationship Type Sequence of a Division, Price Item, and Price Item Parameters.....	605
Searching Relationship Type Sequence for a Division.....	606
Defining Relationship Type Sequence for a Division.....	607
Editing Relationship Type Sequence of a Division.....	608
Deleting Relationship Type Sequence of a Division.....	609
Viewing Relationship Type Sequence of a Division.....	609
Multiple Parameter Based Post-Processing Pricing.....	610

## **Chapter VI: Division.....613**

Division.....	614
Division - Main.....	616
Division - Access Groups.....	617
Division - Price Items.....	618
Division - Price Lists.....	618
Division - Languages.....	619
Division - Invoice Currencies.....	619
Division - Person Identifier Types.....	619
Division - Algorithms.....	620
Division - Characteristics.....	620
Division - Bill Messages.....	621
Division - Party Char Types.....	621
Division - Bill Cycles.....	622
Division - Account Identifier Types.....	622
Division - Price Item Characteristics.....	622
Searching for a Division.....	623
Defining a Division.....	624
Associating an Access Group with a Division.....	627
Associating a Price Item with a Division.....	628
Associating a Price List with a Division.....	630
Associating a Language with a Division.....	631
Associating an Invoice Currency with a Division.....	632
Associating a Person Identifier Type with a Division.....	634
Associating an Algorithm with a Division.....	635
Defining a Characteristic for a Division.....	641
Associating a Bill Message with a Division.....	642
Associating a Party Characteristic Type with a Division.....	644
Associating a Bill Cycle with a Division.....	645
Associating an Account Identifier Type with a Division.....	646
Defining a Division-Specific Characteristic for a Price Item.....	647
Associating a To Do Type and To Do Role with a Division.....	648

<b>Chapter VII: Approval Workflow.....</b>	<b>651</b>
Most Commonly Used Terms.....	653
Approval Workflow Process.....	653
Prerequisites.....	655
Approval Transaction.....	657
Search Approval Transaction.....	657
Approval Transaction Log.....	661
Searching for an Approval Transaction.....	662
Viewing the Log of an Approval Transaction.....	662
Comparison: New versus Existing.....	663
Approving an Approval Transaction.....	663
Rejecting an Approval Transaction.....	664
Canceling an Approval Transaction.....	665
Modifying an Approval Transaction.....	666
Withdrawing an Approval Transaction.....	667
Resolving an Approval Transaction.....	667
Approve Price Assignment.....	668
Search.....	668
List of Price Assignments.....	671
Approve Price Assignment - Comparison: New versus Existing.....	672
Approval Transaction Log.....	674
Approving a Price Assignment for an Account.....	675
Approving a Price Assignment for a Person.....	676
Approving a Price Assignment for a Price List.....	677
Rejecting a Price Assignment for an Account.....	678
Rejecting a Price Assignment for a Person.....	679
Rejecting a Price Assignment for a Price List.....	681
Canceling a Price Assignment for an Account.....	682
Canceling a Price Assignment for a Person.....	683
Canceling a Price Assignment for a Price List.....	685
Modify Price Assignment.....	686
Search.....	686
List of Price Assignments.....	690
Modifying a Price Assignment for an Account.....	691
Modifying a Price Assignment for a Person.....	692
Modifying a Price Assignment for a Price List.....	693
Withdrawing a Price Assignment for an Account.....	693
Withdrawing a Price Assignment for a Person.....	694
Withdrawing a Price Assignment for a Price List.....	695
Viewing the Log of an Approval Transaction.....	696
Resolve Price Assignment.....	697
Search.....	697
List of Price Assignments.....	701
Resolving a Price Assignment for an Account.....	702
Resolving a Price Assignment for a Person.....	703
Resolving a Price Assignment for a Price List.....	704
Withdrawing a Price Assignment for an Account.....	704
Withdrawing a Price Assignment for a Person.....	705
Withdrawing a Price Assignment for a Price List.....	706
Viewing the Log of an Approval Transaction.....	707
Approval Workflow Group (Used for Searching).....	708
Search Approval Workflow Group.....	708
Searching for an Approval Workflow Group.....	709
Viewing the Approval Workflow Group Details.....	710

Defining an Approval Workflow Group.....	710
Adding a Business Object.....	714
Defining a Group BO Relation.....	716
Approval Workflow Group (Used for Viewing).....	717
Approval Workflow Group.....	718
Editing an Approval Workflow Group.....	720
Deleting an Approval Workflow Group.....	720
Editing a Business Object.....	721
Deleting a Business Object.....	723
Editing a Group BO Relation.....	723
Deleting a Group BO Relation.....	725
Approval Workflow Chain (Used for Searching).....	725
Search Approval Workflow Chain.....	725
Searching for an Approval Workflow Chain.....	726
Viewing the Approval Workflow Chain Details.....	727
Defining an Approval Workflow Chain.....	727
Defining Approval Levels for an Approval Workflow Chain.....	728
Approval Workflow Chain (Used for Viewing).....	729
Approval Workflow Chain.....	729
Editing an Approval Workflow Chain.....	730
Deleting an Approval Workflow Chain.....	731
Approval Workflow Criterion Type (Used for Searching).....	732
Search Approval Workflow Criterion Type.....	732
Searching for an Approval Workflow Criterion Type.....	732
Viewing the Approval Workflow Criterion Type Details.....	733
Defining an Approval Workflow Criterion Type.....	733
Approval Workflow Criterion Type (Used for Viewing).....	735
Approval Workflow Criterion Type.....	735
Editing an Approval Workflow Criterion Type.....	736
Deleting an Approval Workflow Criterion Type.....	738
Approval Workflow Group Chain Linkage (Used for Searching).....	738
Search Approval Workflow Group Chain Linkage.....	738
Searching for an Approval Workflow Group Chain Linkage.....	739
Viewing the Approval Workflow Group Chain Linkage Details.....	740
Defining an Approval Workflow Group Chain Linkage.....	740
Defining Group Chain Linkage Criteria for an Approval Workflow.....	742
Defining a Field Approval Rule.....	742
Approval Workflow Group Chain Linkage (Used for Viewing).....	744
Approval Workflow Group Chain Linkage.....	745
Editing an Approval Workflow Group Chain Linkage.....	747
Deleting an Approval Workflow Group Chain Linkage.....	748
Approval Workflow Setting (Used for Searching).....	748
Search Approval Workflow Group.....	748
Searching for an Approval Workflow Group.....	749
Viewing the Approval Workflow Setting Details.....	750
Defining Approval Workflow Group Settings.....	750
Approval Workflow Setting (Used for Viewing).....	752
Approval Workflow Group Settings.....	752
Editing Approval Workflow Group Settings.....	754
Deleting Approval Workflow Group Settings.....	754
Regenerating Input and Display UI Maps.....	755
Approval Workflow Reason (Used for Searching).....	755
Approval Workflow Reason List.....	755
Filtering the Approval Workflow Reasons.....	756
Viewing the Approval Workflow Reason Details.....	757
Defining an Approval Workflow Reason.....	757

Approval Workflow Reason (Used for Viewing).....	758
Approval Workflow Reason.....	758
Editing an Approval Workflow Reason.....	759
Deleting an Approval Workflow Reason.....	760

## **Chapter VIII: Rules Engine.....761**

Rule Type (Used for Searching).....	763
Search Rule Type.....	763
Searching for a Rule Type.....	764
Defining a Rule Type.....	765
Defining Input and Output Parameters for a Rule Type.....	767
Associating a Characteristic Entity with a Rule Type.....	768
Associating an Algorithm with a Rule Type.....	769
Editing a Rule Type.....	770
Deleting a Rule Type.....	772
Copying a Rule Type.....	773
Viewing the Rule Type Details.....	775
Rule Type (Used for Viewing).....	775
Rule Type.....	775
Viewing the Rule Type Details.....	776
Editing a Rule Type.....	777
Rule.....	779
Search.....	779
Searching for a Rule.....	780
Viewing the Rule Details.....	781
Defining a Rule.....	781
Editing a Rule.....	785
Deleting a Rule.....	790
Copying a Rule.....	790
View Rule.....	791
Rule Information.....	791
Viewing the Rule Details.....	793
Rule Check.....	794
Rule Check.....	795

## **Chapter IX: Alternate Sequential Bill Numbers..... 797**

Sequential Bill Number Generation Algorithms.....	798
C1_ALTBLLSYS.....	798
C1_ALTBLSYS1.....	798
C1_ALTBLDV.....	801
C1_ALTBLDIV1.....	801
Enabling the Alternate Sequential Bill Numbers Feature.....	804

## **Chapter X: Currency Conversion.....807**

Prerequisites.....	809
Bill Segment Generation.....	810
Adjustment Creation.....	811
Payment and Tender Creation.....	811
Transaction Aggregation.....	812
FT GL Creation.....	812
Currency Conversion Algorithms.....	813
C1_CURALGBS.....	814
C1_CURALGAD.....	815

C1_CURALGPY.....	817
C1_CURALGTFM.....	819
C1_EXCRTBS.....	821
C1_EXCRTAD.....	822
C1_EXCRTPY.....	824
C1_EXCRTTFM.....	826
FTFREZGLEXTN.....	829
C1_EXCRTOVRD.....	831
Exchange Rate (Used for Searching).....	832
Search Exchange Rate.....	832
Searching for an Exchange Rate.....	835
Defining an Exchange Rate.....	836
Defining Characteristics for an Exchange Rate.....	839
Editing an Exchange Rate.....	840
Deleting an Exchange Rate.....	842
Exchange Rate (Used for Viewing).....	843
Exchange Rate.....	843
Exchange Rate Log.....	845
Viewing the Exchange Rate Details.....	846

## **Chapter XI: Transaction Feed Management.....847**

Prerequisites.....	848
Transaction Rating Before Billing.....	848
Transaction Aggregation.....	856
Header Validation.....	857
Transaction Validation and Initial Price Item Determination.....	859
Price Item Pricing Verification.....	870
Aggregation.....	875
Clean Up.....	879
Transaction Aggregation Batch Processing.....	881
Transaction Disaggregation.....	884
Transaction Disaggregation Batch Processing.....	891
Reseeding.....	892
Transaction Cancellation.....	895
Transaction Cancellation Batch Processing.....	898
Transaction Rollback.....	899
Feed Status Transition.....	901
Transaction Status Transition.....	902
Transaction Leg Status Transition.....	903
Transaction Data File.....	911
Error List.....	914
Feed Management Dashboard.....	950
Search - Feed Level.....	950
Division Level Information.....	952
Transaction Level Information.....	953
Transaction Leg Information.....	954
Transaction Leg Service Quantity.....	955
Transaction Leg Calculation Lines.....	955
Transaction Leg Calc Line Characteristics.....	957
Searching for a Transaction Feed.....	957
Viewing Division Level Details of a Transaction Feed.....	958
Viewing Transactions that Belong to a Division.....	958
Viewing Legs of a Transaction.....	958
Viewing the SQIs Calculated for a Transaction Leg.....	959
Viewing the Calculation Lines of a Transaction Leg.....	960



Viewing Characteristics of a Calculation Line.....	960
View Billed Transactions.....	961
Search Bill.....	961
Bill Segments.....	963
Transaction Details.....	964
SQ Details.....	965
Searching for a Bill.....	965
Viewing the Bill Segments of a Bill.....	966
Viewing Transactions for which the Bill Segment is Generated.....	966
Viewing SQIs Calculated on the Billable Charge.....	967
Transaction Details.....	967
Search.....	967
Searching for an UPLD Transaction.....	968
Searching for an INPD Transaction.....	971
Searching for an COMP Transaction.....	973
Searching for an CNCL Transaction.....	975
Searching for an EROR Transaction.....	977
Searching for an IGNR Transaction.....	979
Searching for an INVL Transaction.....	982
Viewing the Transaction Legs.....	984
Viewing Error Messages.....	986
Viewing the Transaction Details.....	986
Adding a Transaction.....	988
Copying a Transaction.....	991
Transaction Source.....	993
Search Transaction Source.....	994
Searching for a Transaction Source.....	994
Defining a Transaction Source.....	995
Editing a Transaction Source.....	996
Deleting a Transaction Source.....	996
Copying a Transaction Source.....	997
Transaction Record Type.....	998
Search Transaction Record Type.....	998
Searching for a Transaction Record Type.....	999
Defining a Transaction Record Type.....	1000
Editing a Transaction Record Type.....	1005
Deleting a Transaction Record Type.....	1011
Copying a Transaction Record Type.....	1012
Transaction Aggregation Rule.....	1017
Transaction Aggregation Rules.....	1017
Defining Transaction Aggregation Rule for an SQL.....	1018
Editing Transaction Aggregation Rule of an SQL.....	1019
Deleting Transaction Aggregation Rule of an SQL.....	1020
Schedule.....	1021
Search Schedule.....	1021
Searching for a Schedule.....	1022
Viewing the Schedule Details.....	1022
Defining a Schedule.....	1023
Editing a Schedule.....	1024
Deleting a Schedule.....	1025
Disaggregation Request.....	1025
Search Disaggregation Request.....	1026
Searching for a Disaggregation Request.....	1029
Creating a Disaggregation Request.....	1030
Deleting a Disaggregation Request.....	1035
Accumulation Data.....	1035

**Chapter XII: Upload Validated Payment Data..... 1037**

Payment Upload Process.....	1038
Upload Payment Records in the Pre-Staging Area.....	1038
Move Payment Records to the Staging Area.....	1039
Create Payment Events and Payments.....	1039
Prerequisites.....	1040
CSV File Format.....	1041
Payment Data File Status Transition.....	1043
Payment Record Status Transition.....	1043
Error Messages.....	1045
Payment Upload.....	1049
Search Payment Data File.....	1050
Payment Data Records.....	1052
Payment Data File Log.....	1053
Searching for a Payment Data File.....	1054
Uploading a Payment Data File.....	1054
Replacing an Existing File.....	1056
Cancelling a Payment Data File.....	1057
Moving the Payment Records to the Staging Area.....	1057
Editing a Payment Staging Record.....	1058
Viewing the Records of a Payment Data File.....	1059
Viewing the Log of a Payment Data File.....	1059
Viewing the Error Messages.....	1060

**Chapter XIII: Freeze Payments on Notification.....1061**

Freeze Payments on Notification Process.....	1063
Creating Automatic Payments and Refunds.....	1063
Generating a Flat File.....	1063
Uploading Response from Auto Clearing House (ACH).....	1063
Freezing or Canceling Automatic Payments.....	1064
Voiding Refund Requests and Canceling Refund Adjustments.....	1065
Generating To Do Entries.....	1065
Creating Tender Controls.....	1065
Prerequisites.....	1066
Automatic Payment or Refund Clearing Staging Record Status Transition.....	1067
EDI 824 File Format.....	1067
Sample EDI 824 File Format.....	1068
Automatic Payment and Refund Upload Reason.....	1069
Upload Reasons.....	1069
Defining an Upload Reason.....	1070
Editing an Upload Reason.....	1072
Deleting an Upload Reason.....	1074
Automatic Payment and Refund Clearing Staging.....	1074
Search Clearing Record.....	1075
Associated Clearing Staging Records.....	1077
Clearing Staging Upload Reasons.....	1078
Clearing Staging Characteristics.....	1078
Searching for a Clearing Record.....	1079
Viewing the Clearing Staging Records Associated to a Clearing Record.....	1079
Viewing the Upload Reason Specified in the Clearing Staging Record.....	1080
Viewing the Characteristics of the Clearing Staging Record.....	1080
Editing a Clearing Staging Record.....	1081
Defining Characteristics for a Clearing Staging Record.....	1082

Deleting a Clearing Staging Record.....	1083
<b>Chapter XIV: Trial Billing.....</b>	<b>1085</b>
Trial Bill (Used for Searching).....	1087
Search Trial Bill .....	1087
Searching for a Trial Bill.....	1088
Viewing the Trial Bill Details.....	1089
Trial Bill (Used for Viewing).....	1090
Trial Bill.....	1090
Trial Bill Segments.....	1091
Trial Bill Segment Calc Lines.....	1093
Trial Bill Segment SQ Details.....	1094
Trial Bill Segment Financial Details.....	1094
Printing a Trial Bill in the PDF Format.....	1095
Viewing the Segments of a Trial Bill.....	1095
Filtering the Trial Bill Segments.....	1096
Viewing the Calc Lines of a Trial Bill Segment.....	1096
Viewing the SQ Details of a Trial Bill Segment.....	1097
Viewing the Financial Details of a Trial Bill Segment.....	1098
<b>Chapter XV: GL Account Validation.....</b>	<b>1099</b>
Static GL Account Validation.....	1100
Dynamic GL Account Validation.....	1100
<b>Chapter XVI: Upload Validated Adjustment Data.....</b>	<b>1101</b>
Prerequisites.....	1103
CSV File Format.....	1103
Adjustment Upload Request (Without Approval) Status Transition.....	1104
Adjustment Upload Request (With Approval) Status Transition.....	1105
Algorithms Used in C1-ADJUPLD.....	1106
Upload Request Type.....	1109
Upload Request Type List.....	1110
Upload Request Type.....	1111
Defining an Upload Request Type.....	1114
Defining Characteristics for an Upload Request Type.....	1120
Editing an Upload Request Type.....	1121
Copying an Upload Request Type.....	1125
Mapping an Upload Request Type.....	1129
Deleting an Upload Request Type.....	1130
Viewing the Upload Request Type Details.....	1131
Adjustment Upload Request (Used for Searching).....	1132
Search Adjustment Upload Request.....	1132
Searching for an Adjustment Upload Request.....	1134
Uploading an Adjustment Data File.....	1134
Replacing an Adjustment Data File.....	1137
Viewing the Adjustment Upload Request Details.....	1139
Adjustment Upload Request (Used for Viewing).....	1140
Adjustment Upload Request - Main.....	1140
Adjustment Upload Request.....	1140
Adjustment Data Records.....	1143
Adjustment Upload Request - Log.....	1144
Adjustment Upload Request Log.....	1144
Cancelling an Adjustment Data File.....	1144

Creating Adjustments for an Adjustment Data File.....	1145
Submitting an Adjustment Data File for Approval.....	1146
Approving an Adjustment Data File.....	1147
Rejecting an Adjustment Data File.....	1148
Viewing the Log of an Adjustment Upload Request.....	1149
Adding a Log Entry for an Adjustment Upload Request.....	1150

## **Chapter XVII: Payment Request..... 1153**

Prerequisites.....	1155
Payment Request (Without Approval) Status Transition.....	1156
Payment Request (With Approval) Status Transition.....	1157
Algorithms Used in C1-PaymentRequest.....	1158
Algorithms Used in C1-PaymentTransferRequest.....	1162
Payment Request Type.....	1167
Payment Request Type List.....	1167
Payment Request Type.....	1168
Defining a Payment Request Type.....	1170
Defining Characteristics for a Payment Request Type.....	1173
Editing a Payment Request Type.....	1174
Copying a Payment Request Type.....	1177
Deleting a Payment Request Type.....	1180
Viewing the Payment Request Type Details.....	1181
Payment Request (Used for Searching).....	1181
Search Payment Request.....	1182
Searching for a Payment Request.....	1184
Viewing the Payment Request Details.....	1185
Payment Request (Used for Viewing).....	1186
Payment Request.....	1186
Payment Distribution.....	1192
Creating a Payment Creation Request.....	1194
Defining Characteristics for a Payment Tender.....	1199
Editing the Payment Amount.....	1200
Editing a Payment Request.....	1202
Deleting a Payment Request.....	1205
Distributing the Tender or Payment Amount.....	1206
Distributing and Freezing the Tender or Payment Amount.....	1207
Redistributing the Tender or Payment Amount.....	1208
Editing the Payment Segment Amount.....	1209
Freezing Payments Created Through a Payment Request.....	1211
Submitting a Payment Request for Approval.....	1212
Approving a Payment Request.....	1212
Rejecting a Payment Request.....	1214
Discarding a Payment Request.....	1216
Viewing the Log of a Payment Request.....	1216
Adding a Log Entry for a Payment Request.....	1217
Payment Event Summary.....	1218
Search Payment Event.....	1218
Payments.....	1221
Payment Segments.....	1223
Searching for a Payment Event.....	1223
Creating a Payment Transfer Request.....	1224
Cancelling a Payment Event.....	1228
Deleting a Payment Event.....	1229
Viewing Payments Created Through a Payment Event.....	1230
Cancelling a Payment.....	1230

Deleting a Payment.....	1231
Viewing Payment Segments of a Payment.....	1231

## **Chapter XVIII: Account Receivable Central..... 1233**

Single Offset.....	1234
Mass Offset.....	1234
Cross Currency Offset.....	1235
Hold.....	1235
Refund.....	1236
Write Off.....	1236
Dispute.....	1236
Account Receivable Central.....	1236
Search Bill .....	1236
Bill Information.....	1240
Offset Details.....	1240
Hold Details.....	1240
Garnishment Details.....	1241
Bill Line Items.....	1241
Searching for a Bill.....	1241
Viewing the Bill Details.....	1242

## **Chapter XIX: Offset Request..... 1243**

Single Offset.....	1245
Mass Offset.....	1246
Cross Currency Offset.....	1249
Prerequisites.....	1251
Offset Request (Without Approval) Status Transition.....	1252
Offset Request (With Approval) Status Transition.....	1253
Algorithms Used in C1-OffsetRequest.....	1255
C1-OFFST-INF.....	1256
F1-TODOCOMPL.....	1256
C1-OFFSUBENT.....	1256
C1-OFFAPPENT.....	1256
C1-OFFAPPEXT.....	1257
C1-OFSAPRENT.....	1257
F1-AT-RQJ.....	1257
C1-OFST-DIST.....	1257
C1-UPD-HOLD.....	1258
C1-UPD-FUND.....	1258
C1-DFRUNAPLY.....	1258
C1-UNAPOFST.....	1259
C1-UPDT-FUND.....	1259
C1-WTBS-CRBL.....	1259
Additional Algorithms Used in Offset Request.....	1259
C1-OFST-AMT.....	1259
C1-WTBS-CRBL.....	1260
Offset Request Type.....	1260
Offset Request Type List.....	1260
Offset Request Type.....	1261
Defining an Offset Request Type.....	1263
Defining a Characteristic for an Offset Request Type.....	1268
Editing an Offset Request Type.....	1269
Deleting an Offset Request Type.....	1274
Copying an Offset Request Type.....	1275

Viewing the Offset Request Type Details.....	1279
Offset Request (Used for Searching).....	1280
Search Offset Request.....	1280
Searching for an Offset Request.....	1283
Creating an Offset Request.....	1284
Viewing the Offset Request Details.....	1286
Offset Request (Used for Viewing).....	1287
Offset Request - Main.....	1287
Offset Request.....	1287
Selected Bills.....	1290
Search Bill.....	1291
Offset Request Adjustments.....	1296
Offset Request - Log.....	1296
Offset Request Log.....	1296
Viewing the Debit and Credit Bills Added to an Offset Request.....	1297
Viewing the Adjustments Created Through an Offset Request.....	1297
Adding a Debit or Credit Bill to an Offset Request.....	1298
Editing an Offset Request.....	1299
Defining a Characteristic for an Offset Request.....	1301
Editing the Offset Amount of a Debit or Credit Bill.....	1302
Removing a Debit or Credit Bill from an Offset Request.....	1303
Deleting an Offset Request.....	1303
Submitting an Offset Request.....	1304
Approving an Offset Request.....	1306
Rejecting an Offset Request.....	1308
Unapplying an Offset Request.....	1310
Viewing the Log of an Offset Request.....	1311
Adding a Log Entry for an Offset Request.....	1311

## **Chapter XX: Funding Request.....1313**

Prerequisites.....	1316
Funding Request (Without Approval) Status Transition.....	1316
Funding Request (With Approval) Status Transition.....	1317
Algorithms Used in C1-FundingReq.....	1318
C1-FUNDINFO.....	1319
C1-FUNDSUBMT.....	1319
C1-FUNDAPP.....	1320
C1-FUNDAPRVD.....	1320
F1-TODOCOMPL.....	1320
F1-AT-RQJ.....	1320
C1-FNDRESUBM.....	1321
C1-FUNDVAL.....	1321
C1-FUNDAPAY.....	1321
C1-FUNDADJCR.....	1321
C1-FUNDCANCL.....	1322
Funding Request Type.....	1322
Funding Request Type List.....	1322
Funding Request Type.....	1323
Defining a Funding Request Type.....	1326
Defining a Characteristic for a Funding Request Type.....	1333
Editing a Funding Request Type.....	1334
Deleting a Funding Request Type.....	1341
Copying a Funding Request Type.....	1342
Viewing the Funding Request Type Details.....	1349
Funding Request (Used for Searching).....	1350

Search Funding Request.....	1350
Searching for a Funding Request.....	1353
Creating a Funding Request.....	1354
Viewing the Funding Request Details.....	1355
Funding Request (Used for Viewing).....	1355
Funding Request - Main.....	1355
Funding Request.....	1356
Search Bill.....	1359
Funding Request - Bills.....	1363
Currency Statistics.....	1363
Selected Bills.....	1364
Funding Payment Details.....	1367
Funding Adjustments.....	1367
Funding Request - Log.....	1367
Funding Request Log.....	1367
Adding a Debit or Credit Bill to a Funding Request.....	1368
Deleting a Debit or Credit Bill from a Funding Request.....	1369
Excluding a Bill from a Funding Request.....	1370
Editing a Funding Request.....	1372
Defining a Characteristic for a Funding Request.....	1373
Deleting a Funding Request.....	1374
Cancelling a Funding Request.....	1375
Submitting a Funding Request.....	1376
Approving a Funding Request.....	1378
Rejecting a Funding Request.....	1380
Requesting to Resubmit a Funding Request.....	1382
Withdrawing a Funding Request.....	1383
Transferring the Funding Amount of a Credit Bill to a Garnishment Contract.....	1384
Viewing the Garnishment Details of a Credit Bill.....	1385
Viewing the Payments Created Through a Funding Request.....	1386
Viewing the Adjustments Created Through a Funding Request.....	1387
Viewing the Log of a Funding Request.....	1387
Adding a Log Entry for a Funding Request.....	1388

## **Chapter XXI: Refund/Write Off Request..... 1389**

Refund Request (Without Approval) Status Transition.....	1391
Refund Request (With Approval) Status Transition.....	1391
Write Off Request (Without Approval) Status Transition.....	1392
Write Off Request (With Approval) Status Transition.....	1393
Algorithms Used in C1-RefundReq.....	1394
Algorithms Used in C1-WORequest.....	1399
Prerequisites.....	1403
Refund/Write Off Request Type.....	1403
Refund/Write Off Request Type List.....	1407
Refund/Write Off Request Type.....	1408
Defining a Refund or Write Off Request Type.....	1410
Defining Characteristics for a Refund or Write Off Request Type.....	1413
Editing a Refund or Write Off Request Type.....	1414
Copying a Refund or Write Off Request Type.....	1418
Deleting a Refund or Write Off Request Type.....	1421
Viewing the Refund or Write Off Request Type Details.....	1422
Refund/Write Off Request.....	1423
Search Refund/Write Off Request.....	1423
Searching for a Refund or Write Off Request.....	1427
Creating a Refund Request.....	1428

Creating a Write Off Request.....	1430
Viewing the Refund Request Details.....	1433
Viewing the Write Off Request Details.....	1433
Refund Request.....	1434
Refund Request - Main.....	1435
Refund Request.....	1435
Refund Details.....	1437
Bill Line Items.....	1438
Refund Request - Bills.....	1439
Search Bills.....	1439
Bill Line Items.....	1441
Refund Request - Payments.....	1441
Search Payment Event.....	1442
Payments.....	1443
Refund Request - Log.....	1443
Refund Request Log.....	1444
Creating a Refund Request.....	1444
Defining Characteristics for a Refund Request.....	1447
Adding a Payment Event to the Refund Request.....	1448
Adding a Payment to the Refund Request.....	1449
Adding a Credit Bill to the Refund Request.....	1450
Adding a Credit Bill Line Item to the Refund Request.....	1451
Editing a Refund Request.....	1453
Editing the Refund Details.....	1455
Deleting a Refund Request.....	1457
Deleting a Bill from the Refund Request.....	1457
Deleting a Bill Line Item from the Refund Request.....	1458
Submitting a Refund Request.....	1458
Approving a Refund Request.....	1461
Rejecting a Refund Request.....	1463
Viewing the Log of a Refund Request.....	1464
Adding a Log Entry for a Refund Request.....	1465
Voiding a Refund Request.....	1466
Write Off Request.....	1467
Write Off Request - Main.....	1468
Write Off Request.....	1468
Write Off Details.....	1470
Bill Line Items.....	1471
Write Off Request - Bills.....	1472
Search Bills.....	1472
Bill Line Items.....	1473
Write Off Request - Log.....	1474
Write Off Request Log.....	1474
Creating a Write Off Request.....	1475
Defining Characteristics for a Write Off Request.....	1477
Adding a Debit Bill to the Write Off Request.....	1478
Adding a Debit Bill Line Item to the Write Off Request.....	1480
Editing a Write Off Request.....	1481
Editing the Write Off Details.....	1483
Deleting a Write Off Request.....	1485
Deleting a Bill from the Write Off Request.....	1485
Deleting a Bill Line Item from the Write Off Request.....	1486
Submitting a Write Off Request.....	1486
Approving a Write Off Request.....	1488
Rejecting a Write Off Request.....	1490
Viewing the Log of a Write Off Request.....	1491



Adding a Log Entry for a Write Off Request.....	1492
Cancelling a Write Off Request.....	1493

## **Chapter XXII: Hold Request.....1495**

Hold Request (Without Approval) Status Transition.....	1497
Hold Request (With Approval) Status Transition.....	1497
Algorithms Used in C1-HoldRequest.....	1498
Prerequisites.....	1504
Hold Request Type.....	1504
Hold Request Type List.....	1504
Hold Request Type.....	1505
Defining a Hold Request Type.....	1507
Defining Characteristics for a Hold Request Type.....	1510
Editing a Hold Request Type.....	1511
Deleting a Hold Request Type.....	1513
Copying a Hold Request Type.....	1514
Viewing the Hold Request Type Details.....	1517
Hold Request (Used for Searching).....	1518
Search Hold Request.....	1518
Searching for a Hold Request.....	1521
Creating a Hold Request.....	1522
Viewing the Hold Request Details.....	1527
Hold Request (Used for Viewing).....	1528
Hold Request - Main.....	1528
Hold Request.....	1529
Hold Entities.....	1531
Search Account.....	1532
Search Bill.....	1535
Search Person.....	1536
Hold Request - Log.....	1537
Hold Request Log.....	1537
Searching Persons.....	1538
Searching Accounts.....	1539
Searching Bills.....	1539
Adding Persons in a Hold Request.....	1540
Adding Accounts in a Hold Request.....	1540
Adding Bills in a Hold Request.....	1541
Adding Processes in a Hold Request.....	1541
Defining Characteristics for a Hold Request.....	1542
Editing a Hold Request.....	1543
Editing Hold Request Entities.....	1545
Deleting Hold Request Entities.....	1547
Deleting a Hold Request.....	1547
Submitting a Hold Request.....	1548
Approving a Hold Request.....	1549
Releasing a Hold Request.....	1550
Rejecting a Hold Request.....	1551
Resubmitting a Hold Request.....	1553
Viewing the Log of a Hold Request.....	1553
Adding a Log Entry for a Hold Request.....	1554

## **Chapter XXIII: Delinquency Central.....1557**

Prerequisites.....	1558
Delinquency Central (Used for Viewing).....	1558

Search Overdue Process.....	1558
Overdue Events.....	1563
Searching for an Overdue Process.....	1564
Viewing Events of an Overdue Process.....	1564
Viewing the Overdue Process Details.....	1565
Overdue Process Information for Account: {Account ID}.....	1565
Person Information.....	1566
Account Information.....	1566
Customer Contact Details.....	1566
Promise To Pay.....	1566
Hold Details.....	1567
Overdue Bills.....	1567
Payment Arrangement.....	1568
Search Bill.....	1568
Searching for a Bill.....	1569
Adding the Customer Contact Details.....	1570
Creating a Hold Request for an Overdue Process.....	1570
Creating a Payment Arrangement for an Overdue Process.....	1571
Defining a Promise To Pay for an Overdue Process.....	1571

## **Chapter XXIV: Upload Request..... 1573**

Upload Request (Without Approval) Status Transition.....	1576
Upload Request (With Approval) Status Transition.....	1577
Prerequisites.....	1578
Algorithms Used in C1-BillCycleUpdateUpReq.....	1579
Algorithms Used in C1-ContractRiderUpdateUpReq.....	1584
Algorithms Used in C1-HoldUploadRequest.....	1589
Algorithms Used in C1-RefundUploadRequest.....	1596
Algorithms Used in C1-WriteOffUploadRequest.....	1600
Algorithms Used in C1-BillableChargeUploadRequest.....	1604
Algorithms Used in C1-ReinstatementUploadRequest.....	1608
Algorithms Used in C1-BillGrpSortUploadRequest.....	1614
C1-BLSRTUPLD.....	1615
C1-BLSRTDERV.....	1615
C1-BLSRTVALD.....	1615
F1-AT-RQJ.....	1616
C1-UPLSUBENT.....	1616
C1-DEFERUPLD.....	1616
C1-UPLAPPENT.....	1616
C1-UPLAPPEXT.....	1616
F1-TODOCOMPL.....	1616
C1-BLSRTPROC.....	1617
Algorithms Used in C1-BillLevelUploadRequest.....	1617
C1-BLVUPLDTL.....	1618
C1-BLVLDERIV.....	1618
C1-BLVLVALID.....	1618
F1-AT-RQJ.....	1619
C1-UPLSUBENT.....	1619
C1-DEFERUPLD.....	1619
C1-UPLAPPENT.....	1619
C1-UPLAPPEXT.....	1619
F1-TODOCOMPL.....	1619
C1-BLVLVLPRO.....	1619
CSV File Format for Account Bill Cycle Upload Request.....	1620
CSV File Format for Contract Rider Upload Request.....	1620

CSV File Format for Billable Charge Upload.....	1621
CSV File Format for Hold Upload Request.....	1625
CSV File Format for Refund Request Upload.....	1629
CSV File Format for Write Off Request Upload.....	1630
CSV File Format for Reinstatement Upload Request.....	1631
CSV File Format for Bill Group Sorting Upload Request.....	1632
CSV File Format for Bill Group Derivation and Pricing Parameters Upload Request.....	1633
Upload Request Type.....	1635
Upload Request Type List.....	1636
Upload Request Type.....	1637
Defining an Upload Request Type.....	1640
Defining Characteristics for an Upload Request Type.....	1646
Editing an Upload Request Type.....	1647
Deleting an Upload Request Type.....	1651
Copying an Upload Request Type.....	1651
Mapping an Upload Request Type.....	1655
Viewing the Upload Request Type Details.....	1657
Upload Request (Used for Searching).....	1657
Search Upload Request.....	1658
Searching for an Upload Request.....	1659
Viewing the Upload Request Details.....	1660
Creating an Upload Request.....	1660
Defining Characteristics for an Upload Request.....	1663
Upload Request (Used for Viewing).....	1664
Upload Request - Main.....	1664
Upload Request.....	1664
Data Records.....	1667
Upload Request - Log.....	1668
Upload Request Log.....	1668
Editing an Upload Request.....	1669
Deleting an Upload Request.....	1670
Validating an Upload Request.....	1671
Cancelling an Upload Request.....	1671
Submitting an Upload Request.....	1672
Approving an Upload Request.....	1676
Rejecting an Upload Request.....	1679
Viewing the Data Record Details.....	1680
Viewing the Log of an Upload Request.....	1681
Adding a Log Entry for an Upload Request.....	1682

## **Chapter XXV: General Ledger (GL) Accounting Template..... 1683**

GL Accounting Template (Without Approval) Status Transition.....	1688
GL Accounting Template (With Approval) Status Transition.....	1688
Algorithms Used in C1- GLAT.....	1689
Prerequisites.....	1691
GL Accounting Template (Used for Searching).....	1691
Search GL Accounting Template.....	1692
GL Accounting Template Lines.....	1693
Searching for a GL Accounting Template.....	1694
Creating a GL Accounting Template.....	1694
Viewing the GL Accounting Template Details.....	1696
Viewing the GL Accounting Template Lines Details.....	1697
GL Accounting Template (Used for Viewing).....	1697
GL Accounting Template - Main.....	1697
GL Accounting Template.....	1697

GL Accounting Template - Log.....	1699
GL Accounting Template Log.....	1699
Editing a GL Accounting Template.....	1700
Deleting a GL Accounting Template.....	1701
Submitting a GL Accounting Template.....	1702
Approving a GL Accounting Template.....	1703
Rejecting a GL Accounting Template.....	1704
Deactivating a GL Accounting Template.....	1706
Viewing the Log of a GL Accounting Template.....	1707
Adding a Log Entry for a GL Accounting Template.....	1708

## **Chapter XXVI: Payment Agreement Request.....1709**

Payment Agreement Request (Without Approval) Status Transition.....	1712
Payment Agreement Request (With Approval) Status Transition.....	1712
Prerequisites.....	1713
Algorithms Used in CI-PaymentAgreementRequest.....	1714
Payment Agreement Request Type.....	1714
Payment Agreement Request Type List.....	1715
Payment Agreement Request Type.....	1715
Defining a Payment Agreement Request Type.....	1718
Defining Characteristics for a Payment Agreement Request Type.....	1721
Editing a Payment Agreement Request Type.....	1722
Copying a Payment Agreement Request Type.....	1724
Deleting a Payment Agreement Request Type.....	1726
Viewing the Payment Agreement Request Type Details.....	1727
Payment Agreement Request (Used for Searching).....	1728
Search Payment Agreement Request.....	1728
Bill Details.....	1731
Searching for a Payment Agreement Request.....	1732
Creating a Payment Agreement Request.....	1732
Defining Characteristics for a Payment Agreement Request.....	1733
Defining Payment Schedule for a Payment Agreement Request.....	1734
Viewing the Bills Added in the Payment Agreement Request.....	1735
Viewing the Payment Agreement Request Details.....	1736
Payment Agreement Request (Used for Viewing).....	1736
Payment Agreement Request - Main.....	1737
Payment Agreement Request.....	1737
Bill Details.....	1739
Payment Schedule.....	1740
Payment Agreement Request - Bills.....	1740
Search Bills.....	1740
Payment Agreement Request - Log.....	1742
Payment Agreement Request Log.....	1742
Editing a Payment Agreement Request.....	1742
Deleting a Payment Agreement Request.....	1745
Submitting a Payment Agreement Request.....	1746
Removing an Overdue Bill from a Payment Agreement Request.....	1747
Approving a Payment Agreement Request.....	1747
Rejecting a Payment Agreement Request.....	1749
Resubmitting a Payment Agreement Request.....	1750
Filtering Overdue Bills of an Account.....	1751
Adding an Overdue Bill in a Payment Agreement Request.....	1752
Viewing the Log of a Payment Agreement Request.....	1753
Adding a Log Entry for a Payment Agreement Request.....	1754

<b>Chapter XXVII: Inbound Message.....</b>	<b>1757</b>
Customer Inbound Message.....	1758
Prerequisites.....	1758
Customer Inbound Message Status Transition through User Interface.....	1759
Customer Inbound Message Status Transition through a Batch Process.....	1760
Algorithms Used in C1-CustomerInboundMessage.....	1761
C1-AT-RQJ.....	1762
F1-AT-RQJ.....	1762
C1-CINMSGVAL.....	1762
C1-CINMSGPRC.....	1763
C1-TODORETRY.....	1772
C1-TDCRINMSG.....	1772
Customer Inbound Message XML Format.....	1773
Customer Inbound Message Schema.....	1790
Sample Customer Inbound Message.....	1793
Membership Inbound Message.....	1796
Prerequisites.....	1796
Membership Inbound Message Status Transition through User Interface.....	1797
Membership Inbound Message Status Transition through a Batch Process.....	1798
Algorithms Used in C1-MemberInboundMessage.....	1799
C1-AT-RQJ.....	1800
F1-AT-RQJ.....	1800
C1-INMEMEVAL.....	1800
C1-INMEMEPRC.....	1801
C1-TODORETRY.....	1808
C1-TDCRINMSG.....	1808
F1-TODOCOMPL.....	1809
Membership Inbound Message XML Format.....	1809
Membership Inbound Message Schema.....	1822
Sample Membership Inbound Message.....	1824
ASO Customer Inbound Message.....	1826
Prerequisites.....	1828
ASO Customer Inbound Message Status Transition through User Interface.....	1828
ASO Customer Inbound Message Status Transition through a Batch Process.....	1829
Algorithms Used in C1-ASOCustomerInboundMessage.....	1830
C1-AT-RQJ.....	1831
F1-AT-RQJ.....	1831
C1-ASOCINVAL.....	1831
C1-ASOCINPRC.....	1832
C1-TODORETRY.....	1832
C1-TDCRINMSG.....	1832
ASO Customer Inbound Message XML Format.....	1833
ASO Customer Inbound Message Schema.....	1852
Sample ASO Customer Inbound Message.....	1856
Health Care Inbound Message.....	1863
Prerequisites.....	1869
Health Care Inbound Message Status Transition through User Interface.....	1871
Health Care Inbound Message Status Transition through a Batch Process.....	1872
Algorithms Used in C1-HCInboundMessage.....	1872
C1-AT-RQJ.....	1873
F1-AT-RQJ.....	1873
C1-HCINVAL.....	1873
C1-HCINPROC.....	1874
C1-TODORETRY.....	1874

C1-TDCRINMSG.....	1875
Health Care Inbound Message XML Format.....	1875
Health Care Inbound Message Schema.....	1914
Sample Health Care Inbound Message for Fully-Insured Customer Setup.....	1920
Sample Health Care Inbound Message for Self-Funded Customer Setup.....	1945
Sample Health Care Inbound Message for Pricing Rules.....	1960
Sample Health Care Inbound Message for Membership.....	1968
Inbound Message Type.....	1981
Inbound Message Type List.....	1982
Inbound Message Type.....	1983
Viewing the Inbound Message Type Details.....	1986
Defining an Inbound Message Type.....	1986
Defining a Characteristic for an Inbound Message Type.....	1991
Editing an Inbound Message Type.....	1992
Copying an Inbound Message Type.....	1997
Deleting an Inbound Message Type.....	2001
Inbound Message (Used for Searching).....	2002
Search Inbound Message.....	2002
Searching for an Inbound Message.....	2005
Creating an Inbound Message.....	2006
C1-CustomerStructureInboundMessage.....	2006
C1-MembershipInboundMessage.....	2007
C1-ASOCustomerInboundMessage.....	2007
C1-HCInboundMessage.....	2008
Viewing the Inbound Message Details.....	2008
Inbound Message (Used for Viewing).....	2009
Inbound Message - Main.....	2009
Inbound Message.....	2009
Inbound Message - Message.....	2011
Inbound Message Content.....	2011
Inbound Message - Log.....	2012
Inbound Message Log.....	2012
Editing an Inbound Message.....	2012
Defining a Characteristic for an Inbound Message.....	2013
Deleting an Inbound Message.....	2014
Processing an Inbound Message.....	2015
Using the Retry Option for an Inbound Message.....	2017
Voiding an Inbound Message.....	2018
Viewing the Content of an Inbound Message.....	2018
Viewing the Log of an Inbound Message.....	2019
Adding a Log Entry for an Inbound Message.....	2019

## **Chapter XXVIII: Health Insurance Policy..... 2021**

Pre-requisites (for Fully-Insured Policy).....	2022
Pre-requisites (for Self-Funded Policy).....	2023
Types of Policies.....	2023
Fully-Insured Policy.....	2024
Fully-Insured Policy Activation.....	2025
Fully-Insured Policy Termination.....	2025
Fully-Insured Policy Reinstatement.....	2026
Fully-Insured Policy Renewal.....	2027
Fully-Insured Policy Plan Contract Creation.....	2027
Self-Funded Policy.....	2037
Self-Funded Policy Activation.....	2039
Transition of Self-Funded Policy to Runout Status.....	2040

Transition of Self-Funded Policy to Post Runout Status.....	2040
Self-Funded Policy Renewal.....	2041
Self-Funded Policy Contract Creation.....	2041
Fully-Insured Policy Status Transition.....	2044
Self-Funded Policy Status Transition.....	2045
Membership Status Transition.....	2048
Algorithms Used in C1-POLICY.....	2049
C1-REAUDEVNT.....	2050
C1-POLBOVAL.....	2051
C1-TRNDFLSYS.....	2051
F1-AT-RQJ.....	2051
C1-EVCSTSTAT.....	2052
C1-PLCYTRMRQ.....	2052
C1-POLCYTERM.....	2052
C1-DELTRMLTR.....	2053
C1-PLCYREIRQ.....	2054
C1-POLCYREIN.....	2054
C1-CCPOLRE1.....	2054
Algorithms Used in C1-PolicyPlan.....	2055
C1-PPCONCRE.....	2055
C1-VALPPBO.....	2056
Algorithms Used in C1-Membership.....	2056
C1-FIAUDEV.....	2057
C1-MEMSTPRE.....	2058
C1-VALMEMBO.....	2058
C1-MEMINACT.....	2058
Algorithms Used in C1-ASOPolicy.....	2058
C1-ASOPOLVAL.....	2059
C1-ASOBOPOSP.....	2060
C1-ASOPRUCPY.....	2060
C1-ASOPOLMOA.....	2060
C1-ASOPOLREN.....	2061
C1-ASOPCKTD.....	2061
Policy Type.....	2061
Policy Type List.....	2062
Policy Type.....	2062
Defining a Policy Type.....	2064
Defining a Characteristic for a Policy Type.....	2065
Editing a Policy Type.....	2066
Copying a Policy Type.....	2068
Deleting a Policy Type.....	2069
Viewing the Policy Type Details.....	2070
Policy Person Role.....	2071
Policy Person Role List.....	2071
Defining a Policy Person Role.....	2071
Editing a Policy Person Role.....	2072
Deleting a Policy Person Role.....	2073
Contract Relationship Type.....	2073
Filtering the Contract Relationship Types.....	2073
Defining a Contract Relationship Type.....	2074
Editing a Contract Relationship Type.....	2074
Deleting a Contract Relationship Type.....	2075
Source System Extendable Lookup.....	2076
Extendable Lookup Search.....	2076
Searching for the Source System Extendable Lookup.....	2077
Viewing the Values of the Source System Extendable Lookup.....	2077

Extendable Lookup (Source System).....	2078
Extendable Lookup Value List.....	2078
Extendable Lookup Value.....	2079
Defining a Source System.....	2080
Editing a Source System.....	2081
Copying a Source System.....	2082
Deleting a Source System.....	2083
Viewing the Source System Details.....	2083
Policy (Used for Searching).....	2084
Search Policy.....	2084
Searching for a Policy.....	2088
Viewing the Policy Details.....	2089
Defining a Policy.....	2089
Associating a Person with a Policy.....	2092
Defining a Characteristic for a Policy.....	2093
Policy (Used for Viewing).....	2095
Policy - Main.....	2095
Policy.....	2095
Policy - Plan.....	2102
Plans.....	2102
Memberships.....	2103
Policy - Log.....	2104
Policy Log.....	2104
Activating a Policy.....	2105
Editing a Policy.....	2105
Deleting a Policy.....	2109
Initiating the Cancellation Process for a Fully-Insured Policy.....	2110
Canceling a Fully-Insured Policy.....	2110
Initiating the Termination Process for a Fully-Insured Policy.....	2111
Terminating a Fully-Insured Policy.....	2112
Initiating the Reinstatement Process for a Fully-Insured Policy.....	2112
Reinstating a Fully-Insured Policy.....	2113
Manually Changing the Status of a Self-Funded Policy to Runout.....	2114
Renewing a Self-Funded Policy of a Bill Group.....	2115
Viewing the Plans of a Fully-Insured Policy.....	2117
Viewing the Memberships of a Fully-Insured Policy Plan.....	2118
Viewing the Fully-Insured Policy Plan Details.....	2118
Viewing the Membership Details of a Fully-Insured Policy Plan.....	2119
Defining a Plan for a Fully-Insured Policy.....	2120
Associating a Pricing Rule Type with a Fully-Insured Policy Plan.....	2122
Defining a Characteristic for a Fully-Insured Policy Plan.....	2123
Editing a Plan of a Fully-Insured Policy.....	2124
Viewing the Log of a Policy.....	2126
Adding a Log Entry for a Policy.....	2126
Policy Plan (Used for Viewing).....	2127
Policy Plan.....	2127
Memberships.....	2129
Membership (Used for Searching).....	2130
Search Membership.....	2130
Searching for a Membership.....	2133
Viewing the Membership Details.....	2134
Defining a Membership for a Fully-Insured Policy Plan.....	2134
Defining a Characteristic for a Membership.....	2137
Membership (Used for Viewing).....	2138
Membership - Main.....	2138
Membership.....	2139



Member Persons.....	2141
Other Plans of Main Subscriber.....	2142
Membership - Contracts and Charges.....	2143
Membership Contracts.....	2143
Billable Charges.....	2144
Bill Segment Details.....	2146
Billable Charge Timeline Details.....	2147
Pricing Calculation Details.....	2147
Membership - Log.....	2148
Membership Log.....	2148
Editing a Membership of a Fully-Insured Policy Plan.....	2149
Adding a Person to a Membership.....	2150
Defining a Characteristic for a Member Person.....	2152
Inactivating a Membership.....	2153
Inactivating a Member Person.....	2154
Removing a Person from a Membership.....	2155
Editing the Membership Details of a Person.....	2155
Associating a Contract with a Membership.....	2157
Disassociating a Contract from a Membership.....	2159
Editing the Contract Association Details of a Membership.....	2159
Viewing the Billable Charges Created for a Membership.....	2161
Viewing the Bill Segments Generated for a Billable Charge.....	2161
Viewing the Timeline Details of a Membership Billable Charge.....	2162
Viewing the Pricing Calculation Details of a Timeline.....	2162
Viewing the Log of a Membership.....	2163
Adding a Log Entry for a Membership.....	2163

## **Chapter XXIX: Upload Lockbox Payment and Remittance Advices**

### **Overview.....2165**

Prerequisites.....	2167
EDI 820 Flat File Description.....	2167
Sample EDI 820 Flat File.....	2169
Upload EDI 820 Files in ORMB.....	2172

## **Chapter XXX: Deferred Revenue Recognition.....2175**

Prerequisites.....	2177
Deferred Revenue Recognition Status Transition.....	2177
Algorithms Used in Deferred Revenue Recognition.....	2179
Deferred Revenue Recognition Template (Used for Searching).....	2184
Search Deferred Revenue Recognition Template.....	2184
Searching for a Deferred Revenue Recognition Template.....	2185
Defining a Deferred Revenue Recognition Template.....	2186
Associating Algorithms with a Deferred Revenue Recognition Template.....	2188
Associating Deferred Revenue Recognition Template With A Division.....	2189
Defining Characteristics for a Deferred Revenue Recognition Template.....	2190
Viewing the Deferred Revenue Recognition Template Details.....	2191
Deferred Revenue Recognition Template (Used for Viewing).....	2192
Deferred Revenue Recognition Template.....	2192
Editing a Deferred Revenue Recognition Template.....	2194
Deleting a Deferred Revenue Recognition Template.....	2195
Viewing the Deferred Revenue Recognition Template Details.....	2195
Deferred Revenue Recognition (Used for Searching).....	2196
Search Deferred Revenue Recognition.....	2196
Searching for a Deferred Revenue Recognition.....	2200

Viewing the Deferred Revenue Recognition Details.....	2201
Deferred Revenue Recognition (Used for Viewing).....	2202
Deferred Revenue Recognition - Main.....	2202
Deferred Revenue Recognition.....	2202
Associated Deferred Revenue Recognitions.....	2204
Recognition Schedule.....	2205
Revenue Recognition Items.....	2205
Deferred Revenue Recognition - Log.....	2205
Deferred Revenue Recognition Log.....	2205
Editing a Deferred Revenue Recognition.....	2206
Creating the Deferred Revenue Recognition Schedule.....	2207
Defining Characteristics for a Deferred Revenue Recognition.....	2207
Adding Related Deferred Revenue Recognitions.....	2208
Editing the Deferred Revenue Recognition Schedule Details.....	2209
Viewing the Log of a Deferred Revenue Recognition.....	2210
Adding a Log Entry for a Deferred Revenue Recognition.....	2211

## **Chapter XXXI: Reconciliation..... 2213**

Reconciliation Status Transition.....	2216
Pay Instruction Status Transition.....	2217
Discrepancy Report Status Transition.....	2219
EDI 820 File Format For Reconciliation.....	2219
Sample EDI 820 File Format.....	2220
Algorithms Used in C1-MemberReconType.....	2221
C1-REOCNPEP.....	2221
Algorithms Used in C1-MemberReconciliation.....	2222
C1-RECONINFO.....	2223
C1-MRECONVAL.....	2223
F1-AT-RQJ.....	2223
F1-TDCREATE.....	2223
C1-VALPAYINS.....	2224
F1-TODOCOMPL.....	2224
C1-MRECONVAL.....	2224
C1-MONPAYINS.....	2225
C1-TRNPAYRCN.....	2225
C1-RCOPNPYIN.....	2226
C1-RCNOPNMR.....	2226
C1-RCMONPNCN.....	2226
C1-CANPAYINS.....	2227
C1-CANRCNPAY.....	2227
C1-RCNCANLTD.....	2227
Algorithms Used in C1-PayInstruction.....	2227
C1-MPAYININF.....	2228
C1-PYINDRVAN.....	2228
C1-PIRECOCIL.....	2229
C1-PYICNADJ.....	2230
F1-AT-RQJ.....	2230
Algorithms Used in C1-MemberDiscReportType.....	2230
C1-DISCPEP.....	2231
Algorithms Used in C1-DiscrepancyReport.....	2231
F1-AT-RQJ.....	2231
C1-DISRINFO.....	2231
C1-VALNEWDIS.....	2232
C1-CRDSLNITM.....	2232
F1-TODOCOMPL.....	2232

C1-VALCMPDIS.....	2232
Reconciliation Type.....	2232
Reconciliation Type List.....	2233
Reconciliation Type.....	2233
Defining a Reconciliation Type.....	2235
Defining Characteristics for a Reconciliation Type.....	2237
Associating an Algorithm with a Reconciliation Type.....	2237
Editing a Reconciliation Type.....	2239
Deleting a Reconciliation Type.....	2240
Copying a Reconciliation Type.....	2241
Viewing the Reconciliation Type Details.....	2242
Reconciliation (Used for Searching).....	2243
Search Reconciliation.....	2243
Searching for a Reconciliation.....	2246
Viewing the Reconciliation Details.....	2247
Reconciliation (Used for Viewing).....	2247
Reconciliation - Main.....	2248
Reconciliation.....	2248
Pay Instructions.....	2250
Reconciliation - Log.....	2251
Reconciliation Log.....	2251
Editing a Reconciliation.....	2252
Defining Characteristics for a Reconciliation.....	2252
Deleting a Reconciliation.....	2254
Submitting Pay Instructions for a Reconciliation.....	2254
Reconciling Pay Instructions.....	2255
Adding a Log Entry for a Reconciliation.....	2256
Viewing the Log of a Reconciliation.....	2256
Canceling a Reconciliation.....	2257
Viewing the Pay Instruction Details.....	2258
Pay Instruction.....	2258
Pay Instruction - Main.....	2259
Pay Instruction.....	2259
Reconciliation Adjustments.....	2259
Related Objects.....	2260
Pay Instruction - Log.....	2260
Pay Instruction Log.....	2260
Adding a Log Entry for a Pay Instruction.....	2261
Viewing the Log of a Pay Instruction.....	2261
Discrepancy Report Type.....	2262
Discrepancy Report Type List.....	2262
Discrepancy Report Type.....	2263
Defining a Discrepancy Report Type.....	2264
Defining Characteristics for a Discrepancy Report Type.....	2266
Editing a Discrepancy Report Type.....	2267
Deleting a Discrepancy Report Type.....	2268
Copying a Discrepancy Report Type.....	2268
Viewing the Discrepancy Report Type Details.....	2270
Discrepancy Report (Used for Searching).....	2270
Search Discrepancy Report.....	2270
Searching for a Discrepancy Report.....	2273
Creating a Discrepancy Report.....	2274
Viewing the Discrepancy Report Details.....	2275
Discrepancy Report (Used for Viewing).....	2275
Discrepancy Report - Main.....	2276
Discrepancy Report.....	2276

Discrepancy Line Items.....	2277
Discrepancy Line Item Related Objects.....	2278
Discrepancy Line Items Characteristics Zone.....	2279
Discrepancy Report - Log.....	2279
Discrepancy Report Log.....	2279
Editing a Discrepancy Line Item.....	2279
Deleting a Discrepancy Report.....	2281
Finalizing a Discrepancy Report.....	2281
Adding a Log Entry for a Discrepancy Report.....	2282
Viewing the Log of a Discrepancy Report.....	2282

## **Chapter XXXII: Self-Funded Pricing.....2285**

Prerequisites.....	2286
Approval Workflow for the Self-Funded Pricing Rules.....	2286
Line Item Extendable Lookup.....	2287
Extendable Lookup Search.....	2288
Searching for the Line Item Extendable Lookup.....	2289
Viewing the Values of the Line Item Extendable Lookup.....	2289
Extendable Lookup (Line Item).....	2290
Extendable Lookup Value List.....	2290
Extendable Lookup Value.....	2291
Defining a Line Item.....	2293
Associating a Line Item with a Pricing Rule Type Category.....	2294
Editing a Line Item.....	2296
Copying a Line Item.....	2298
Deleting a Line Item.....	2300
Viewing the Line Item Details.....	2300
Claim Template Extendable Lookup.....	2301
Extendable Lookup Search.....	2302
Searching for the Claim Template Extendable Lookup.....	2303
Viewing the Values of the Claim Template Extendable Lookup.....	2303
Extendable Lookup (Claim Template).....	2304
Extendable Lookup Value List.....	2304
Extendable Lookup Value.....	2305
Defining a Claim Template.....	2307
Adding a Line Item in a Claim Template.....	2309
Defining the Default Markup or Markdown Values for the Line Items.....	2311
Editing a Claim Template.....	2313
Copying a Claim Template.....	2315
Deleting a Claim Template.....	2316
Viewing the Claim Template Details.....	2317
Rate Option Extendable Lookup.....	2318
Extendable Lookup Search.....	2318
Searching for the Rate Option Extendable Lookup.....	2319
Viewing the Values of the Rate Option Extendable Lookup.....	2320
Extendable Lookup (Rate Option).....	2320
Extendable Lookup Value List.....	2320
Extendable Lookup Value.....	2321
Defining a Rate Option.....	2323
Editing a Rate Option.....	2326
Copying a Rate Option.....	2329
Deleting a Rate Option.....	2331
Viewing the Rate Option Details.....	2332
Pricing Group.....	2333
Viewing the Pricing Groups of a Bill Group.....	2333

Defining a Pricing Group for a Bill Group.....	2334
Editing a Pricing Group of a Bill Group.....	2337
Deleting a Pricing Group of a Bill Group.....	2339
Copying a Pricing Group of a Bill Group.....	2340
Pricing Rule Type.....	2343
Pricing Rule Type List.....	2344
Pricing Rule Type.....	2347
Claim Pricing.....	2354
Defining a Claim Pricing Rule Type.....	2356
Adding Claim Templates in a Claim Pricing Rule Type.....	2359
Adding the Claim-Specific Data in a Pricing Rule Type.....	2360
Editing a Claim Pricing Rule Type.....	2361
Deleting a Claim Pricing Rule Type.....	2364
Viewing the Claim Pricing Rule Type Details.....	2364
Defining a Claim Pricing Rule for a Parent Customer.....	2365
Defining the Markup or Markdown Values for Line Items in a Claim Pricing Rule.....	2367
Defining the Markup or Markdown Values for Line Items for Each Rule in a Claim Pricing Rule.....	2369
Defining Characteristics for a Claim Pricing Rule.....	2371
Editing a Claim Pricing Rule of a Parent Customer.....	2372
Viewing a Claim Pricing Rule of a Parent Customer.....	2374
Deleting a Claim Pricing Rule of a Parent Customer.....	2375
Defining a Claim Pricing Rule for a Bill Group.....	2375
Defining a Claim Pricing Rule for a Bill Group Using a Pricing Group.....	2378
Editing a Claim Pricing Rule of a Bill Group.....	2381
Viewing a Claim Pricing Rule of a Bill Group.....	2382
Deleting a Claim Pricing Rule of a Bill Group.....	2383
Specific Stop-Loss (SSL) Pricing.....	2384
Defining a Specific Stop-Loss (SSL) Pricing Rule Type.....	2386
Adding the SSL-Specific Data in a Pricing Rule Type.....	2389
Editing a Specific Stop-Loss (SSL) Pricing Rule Type.....	2391
Deleting a Specific Stop-Loss (SSL) Pricing Rule Type.....	2394
Viewing the Specific Stop-Loss (SSL) Pricing Rule Type Details.....	2394
Defining a Specific Stop-Loss Pricing Rule for a Parent Customer.....	2395
Defining Accumulation Parameters in a Specific Stop-Loss Pricing Rule.....	2398
Defining Run-in Parameters in a Specific Stop-Loss Pricing Rule.....	2400
Defining Lasering and Exclusion Information in a Specific Stop-Loss Pricing Rule.....	2401
Defining Characteristics for a Specific Stop-Loss Pricing Rule.....	2402
Editing a Specific Stop-Loss Pricing Rule of a Parent Customer.....	2404
Viewing a Specific Stop-Loss Pricing Rule of a Parent Customer.....	2406
Deleting a Specific Stop-Loss Pricing Rule of a Parent Customer.....	2407
Defining a Specific Stop-Loss Pricing Rule for a Bill Group.....	2407
Defining Accumulation Criteria in a Specific Stop-Loss Pricing Rule.....	2410
Defining Claim Pricing Information in a Specific Stop Loss Pricing Rule.....	2412
Defining a Specific Stop-Loss Pricing Rule for a Bill Group Using a Pricing Group.....	2414
Editing a Specific Stop-Loss Pricing Rule of a Bill Group.....	2417
Viewing a Specific Stop-Loss Pricing Rule of a Bill Group.....	2418
Deleting a Specific Stop-Loss Pricing Rule of a Bill Group.....	2419
Aggregate Stop-Loss (ASL) Pricing.....	2420
Defining a Aggregate Stop-Loss (ASL) Pricing Rule Type.....	2422
Adding the ASL-Specific Data in a Pricing Rule Type.....	2425
Editing an Aggregate Stop-Loss (ASL) Pricing Rule Type.....	2427
Deleting an Aggregate Stop-Loss (ASL) Pricing Rule Type.....	2430
Viewing the Aggregate Stop-Loss (ASL) Pricing Rule Type Details.....	2430
Defining an Aggregate Stop-Loss Pricing Rule for a Parent Customer.....	2431
Defining Accumulation Parameters in an Aggregate Stop-Loss Pricing Rule.....	2434

Defining Run-in Parameters in an Aggregate Stop-Loss Pricing Rule.....	2437
Defining Characteristics for an Aggregate Stop-Loss Pricing Rule.....	2438
Editing an Aggregate Stop-Loss Pricing Rule of a Parent Customer.....	2439
Viewing an Aggregate Stop-Loss Pricing Rule of a Parent Customer.....	2442
Deleting an Aggregate Stop-Loss Pricing Rule of a Parent Customer.....	2442
Defining an Aggregate Stop-Loss Pricing Rule for a Bill Group.....	2443
Defining Accumulation Criteria in an Aggregate Stop-Loss Pricing Rule.....	2446
Defining Claim Pricing Rules in an Aggregate Stop-Loss Pricing Rule.....	2448
Defining an Aggregate Stop-Loss Pricing Rule for a Bill Group Using a Pricing Group...	2450
Editing an Aggregate Stop-Loss Pricing Rule of a Bill Group.....	2453
Viewing an Aggregate Stop-Loss Pricing Rule of a Bill Group.....	2454
Deleting an Aggregate Stop-Loss Pricing Rule of a Bill Group.....	2455
Retention Type Claim Based Pricing.....	2456
Defining a Retention Type Claim Based Pricing Rule Type.....	2457
Adding Claim Based Disposition Details in a Pricing Rule Type.....	2460
Editing a Retention Type Claim Based Pricing Rule Type.....	2461
Deleting a Retention Type Claim Based Pricing Rule Type.....	2463
Viewing the Retention Type Claim Based Pricing Rule Type Details.....	2464
Defining a Retention Type Claim Based Pricing Rule for a Parent Customer.....	2465
Defining Characteristics for a Retention Type Claim Based Pricing Rule.....	2468
Editing a Retention Type Claim Based Pricing Rule of a Parent Customer.....	2469
Deleting a Retention Type Claim Based Pricing Rule of a Parent Customer.....	2472
Defining a Retention Type Claim Based Pricing Rule for a Bill Group.....	2473
Defining Characteristics for a Retention Type Claim Based Pricing Rule.....	2475
Editing a Retention Type Claim Based Pricing Rule of a Bill Group.....	2476
Deleting a Retention Type Claim Based Pricing Rule of a Bill Group.....	2479
Defining a Retention Type Claim Based Pricing Rule for a Bill Group Using a Pricing Group.....	2479
Defining Characteristics for a Retention Type Claim Based Pricing Rule for a Bill Group Using a Pricing Group.....	2482
Viewing a Retention Type Claim Based Pricing Rule of a Parent Customer.....	2483
Viewing a Retention Type Claim Based Pricing Rule of a Bill Group.....	2484
Retention Type Enrollment Based Pricing.....	2484
Defining a Retention Type Enrollment Based Pricing Rule Type.....	2486
Adding the Enrollment Specific Data in a Pricing Rule Type.....	2489
Editing a Retention Type Enrollment Based Pricing Rule Type.....	2489
Deleting a Retention Type Enrollment Based Pricing Rule Type.....	2492
Viewing the Retention Type Enrollment Based Pricing Rule Type Details.....	2492
Defining a Retention Type Enrollment Based Pricing Rule for a Parent Customer.....	2493
Defining Characteristics for a Retention Type Enrollment Based Pricing Rule.....	2496
Editing a Retention Type Enrollment Based Pricing Rule of a Parent Customer.....	2497
Deleting a Retention Type Enrollment Based Pricing Rule of a Parent Customer.....	2499
Defining a Retention Type Enrollment Based Pricing Rule for a Bill Group.....	2500
Defining Characteristics for a Retention Type Enrollment Based Pricing Rule.....	2503
Editing a Retention Type Enrollment Based Pricing Rule of a Bill Group.....	2504
Deleting a Retention Type Enrollment Based Pricing Rule of a Bill Group.....	2507
Defining a Retention Type Enrollment Based Pricing Rule for a Bill Group Using a Pricing Group.....	2507
Defining Characteristics for a Retention Type Enrollment Based Pricing Rule for a Bill Group Using a Pricing Group.....	2510
Viewing a Retention Type Enrollment Based Pricing Rule of a Parent Customer.....	2511
Viewing a Retention Type Enrollment Based Pricing Rule of a Bill Group.....	2512
Flat Fee Pricing.....	2513
Defining a One-Time Flat Fee Pricing Rule Type.....	2515
Adding the One-Time Flat Fee Specific Data in a Pricing Rule Type.....	2517
Editing a One-Time Flat Fee Pricing Rule Type.....	2518

Deleting a One-Time Flat Fee Pricing Rule Type.....	2521
Viewing the One-Time Flat Fee Pricing Rule Type Details.....	2522
Defining a One-Time Flat Fee Pricing Rule for a Bill Group.....	2522
Defining Characteristics for a One-Time Flat Fee Pricing Rule.....	2525
Editing a One-Time Flat Fee Pricing Rule of a Bill Group.....	2526
Viewing a One-Time Flat Fee Pricing Rule of a Bill Group.....	2527
Deleting a One-Time Flat Fee Pricing Rule of a Bill Group.....	2528
Defining a Bill Period Based Recurring Flat Fee Pricing Rule Type.....	2529
Adding the Recurring Flat Fee Specific Data in a Pricing Rule Type.....	2532
Editing a Bill Period Based Recurring Flat Fee Pricing Rule Type.....	2533
Deleting a Bill Period Based Recurring Flat Fee Pricing Rule Type.....	2536
Viewing the Bill Period Based Recurring Flat Fee Pricing Rule Type Details.....	2537
Defining a Bill Period Based Recurring Flat Fee Pricing Rule for a Bill Group.....	2537
Defining Characteristics for a Bill Period Based Recurring Flat Fee Pricing Rule.....	2540
Editing a Bill Period Based Recurring Flat Fee Pricing Rule of a Bill Group.....	2541
Viewing a Bill Period Based Recurring Flat Fee Pricing Rule of a Bill Group.....	2542
Deleting a Bill Period Based Recurring Flat Fee Pricing Rule of a Bill Group.....	2543
Defining a Frequency Based Recurring Flat Fee Pricing Rule Type.....	2544
Adding the Recurring Flat Fee Specific Data in a Pricing Rule Type.....	2547
Editing a Frequency Based Recurring Flat Fee Pricing Rule Type.....	2548
Deleting a Frequency Based Recurring Flat Fee Pricing Rule Type.....	2551
Viewing the Frequency Based Recurring Flat Fee Pricing Rule Type Details.....	2551
Defining a Frequency Based Recurring Flat Fee Pricing Rule for a Bill Group.....	2552
Defining Characteristics for a Frequency Based Recurring Flat Fee Pricing Rule.....	2554
Editing a Frequency Based Recurring Flat Fee Pricing Rule of a Bill Group.....	2555
Viewing a Frequency Based Recurring Flat Fee Pricing Rule of a Bill Group.....	2557
Deleting a Frequency Based Recurring Flat Fee Pricing Rule of a Bill Group.....	2558
Ancillary Pricing.....	2558
Defining an Ancillary Pricing Rule Type.....	2561
Adding a Related Pricing Rule Type in an Ancillary Pricing Rule Type.....	2566
Mapping the Transaction Field in an Ancillary Pricing Rule Type.....	2568
Associating an Algorithm with an Ancillary Pricing Rule Type.....	2572
Defining Additional Data in an Ancillary Pricing Rule Type.....	2575
Adding a Price Item in an Ancillary Pricing Rule Type.....	2578
Adding a Price Item Parameter in an Ancillary Pricing Rule Type.....	2581
Defining the Ancillary-Specific Data in an Ancillary Pricing Rule Type.....	2582
Defining Pricing Arrangements in an Ancillary Pricing Rule Type.....	2584
Defining a Characteristic for a Ancillary Pricing Rule Type.....	2585
Editing an Ancillary Pricing Rule Type.....	2586
Deleting an Ancillary Pricing Rule Type.....	2590
Viewing the Ancillary Pricing Rule Type Details.....	2591
Defining an Ancillary Pricing Rule for a Parent Customer.....	2591
Defining Characteristics for an Ancillary Pricing Rule.....	2594
Editing an Ancillary Pricing Rule of a Parent Customer.....	2596
Deleting an Ancillary Pricing Rule of a Parent Customer.....	2598
Defining an Ancillary Pricing Rule for a Bill Group.....	2599
Defining Characteristics for an Ancillary Pricing Rule.....	2602
Editing an Ancillary Pricing Rule of a Bill Group.....	2604
Deleting an Ancillary Pricing Rule of a Bill Group.....	2606
Discount Pricing.....	2607
Types of Discount Arrangement.....	2608
Discount Share.....	2608
Discount Guarantee.....	2608
Defining a Discount Arrangement Pricing Rule Type.....	2608
Associating Algorithms with a Discount Arrangement Pricing Rule Type.....	2612
Defining Additional Data in a Discount Arrangement Pricing Rule Type.....	2615

Adding a Price Item in a Discount Arrangement Pricing Rule Type.....	2617
Adding a Price Item Parameter in a Discount Arrangement Pricing Rule Type.....	2620
Defining a Characteristic for a Discount Arrangement Pricing Rule Type.....	2621
Defining the Discount Specific Data in a Discount Arrangement Pricing Rule Type.....	2622
Editing a Discount Arrangement Pricing Rule Type.....	2625
Deleting a Discount Arrangement Pricing Rule Type.....	2628
Viewing the Discount Arrangement Pricing Rule Type Details.....	2629
Defining a Discount Arrangement Pricing Rule for a Parent Customer.....	2629
Adding the Discount Details in a Discount Arrangement Pricing Rule .....	2632
Defining the Discount Limits in a Discount Arrangement Pricing Rule.....	2633
Excluding a Network or Provider in a Discount Arrangement Pricing Rule.....	2635
Defining a Characteristic for a Discount Arrangement Pricing Rule.....	2636
Editing a Discount Arrangement Pricing Rule of a Parent Customer.....	2637
Deleting a Discount Arrangement Pricing Rule of a Parent Customer.....	2639
Write-Off Charges during Post Runout.....	2640
Level Funding Pricing.....	2640
Defining a Level Funded Pricing Rule Type.....	2644
Associating an Algorithm with a Level Funded Pricing Rule Type.....	2646
Defining Additional Data in a Level Funded Pricing Rule Type.....	2647
Adding a Price Item in a Level Funded Pricing Rule Type.....	2649
Adding a Price Item Parameter in a Level Funded Pricing Rule Type.....	2652
Defining Characteristics for a Level Funded Pricing Rule Type.....	2653
Defining the Level Funded Specific Additional Data in a Level Funded Pricing Rule Type.....	2654
Editing a Level Funded Pricing Rule Type.....	2658
Deleting a Level Funded Pricing Rule Type.....	2661
Viewing the Level Funded Pricing Rule Type Details.....	2661
Defining a Level Funded Pricing Rule for a Parent Customer.....	2662
Defining Accumulation Parameters in a Level Funded Pricing Rule.....	2665
Defining the Final Settlement Rules in a Level Funded Pricing Rule.....	2666
Defining a Characteristic for a Level Funded Pricing Rule.....	2671
Defining a Level Funded Pricing Rule for a Bill Group.....	2672
Defining Accumulation Criteria in a Level Funded Pricing Rule.....	2675
Defining Claim Pricing Information in a Level Funded Pricing Rule.....	2678
Defining Ancillary Pricing Information in a Level Funded Pricing Rule.....	2681
Defining Discount Arrangement Pricing Information in a Level Funded Pricing Rule.....	2684
Defining Retention Type Claim Based and/or Retention Type Enrollment Based Pricing Rule Information in a Level Funded Pricing Rule.....	2686
Defining a Characteristic for a Level Funded Pricing Rule.....	2687
Pricing Rule (Used for Viewing).....	2688
Claim.....	2689
Aggregate Stop-Loss.....	2691
Specific Stop-Loss.....	2697
Retention Type Claim Based.....	2703
Retention Type Enrollment Based.....	2704
Flat Fee.....	2705
Ancillary.....	2707
Discount Arrangement.....	2709
Level Funded.....	2712

## **Chapter XXXIII: Self-Funded Billing..... 2719**

Pre-requisites.....	2721
Bill Group Derivation and Pricing Parameters.....	2722
Related Pricing Rule Type Eligibility.....	2724
Price Item Eligibility.....	2726



Self-Funded Billing Process.....	2727
Transaction Aggregation.....	2727
Stop Loss Calculation.....	2732
Bill Generation.....	2732
Bill Group Derivation.....	2733
Account and Price Item Derivation (for the Claim Pricing Rule Type Category).....	2736
Account and Price Item Derivation (for the Specific Stop-Loss and Aggregate Stop-Loss Pricing Rule Type Categories).....	2741
Account and Price Item Derivation (for the Retention Type Claim Based Pricing Rule Type Category).....	2754
Account and Price Item Derivation (for the Retention Type Enrollment Based Pricing Rule Type Category).....	2766
Account and Price Item Derivation (for the Ancillary Pricing Rule Type Category).....	2776
Bill After Date Determination.....	2785

## **Chapter XXXIV: Fully-Insured Pricing.....2787**

Age Based Pricing.....	2788
Defining an Age Based Pricing Rule Type.....	2790
Associating an Algorithm with an Age Based Pricing Rule Type.....	2792
Adding a Price Item in an Age Based Pricing Rule Type.....	2794
Adding a Price Item Parameter in an Age Based Pricing Rule Type.....	2797
Defining Characteristics for an Age Based Pricing Rule Type.....	2798
Adding Elements for Audit in an Age Based Pricing Rule Type.....	2799
Defining Additional Data in an Age Based Pricing Rule Type.....	2800
Editing an Age Based Pricing Rule Type.....	2801
Deleting an Age Based Pricing Rule Type.....	2803
Viewing the Age Based Pricing Rule Type Details.....	2804
Tier Based Pricing.....	2804
Defining a Tier Based Pricing Rule Type.....	2806
Associating an Algorithm with a Tier Based Pricing Rule Type.....	2808
Adding a Price Item in a Tier Based Pricing Rule Type.....	2810
Adding a Price Item Parameter in a Tier Based Pricing Rule Type.....	2813
Defining Characteristics for a Tier Based Pricing Rule Type.....	2814
Adding Elements for Audit in a Tier Based Pricing Rule Type.....	2815
Editing a Tier Based Pricing Rule Type.....	2816
Deleting a Tier Based Pricing Rule Type.....	2818
Viewing the Tier Based Pricing Rule Type Details.....	2819
Pass-Through Billable Charge.....	2819
Defining a Pass-Through Billable Charge Pricing Rule Type.....	2820
Associating an Algorithm with a Pass-Through Billable Charge Pricing Rule Type.....	2822
Adding a Price Item in a Pass-Through Billable Charge Pricing Rule Type.....	2824
Adding a Price Item Parameter in a Pass-Through Billable Charge Pricing Rule Type.....	2826
Defining Characteristics for a Pass-Through Billable Charge Pricing Rule Type.....	2827
Editing a Pass-Through Billable Charge Pricing Rule Type.....	2828
Deleting a Pass-Through Billable Charge Pricing Rule Type.....	2830
Viewing the Pass-Through Billable Charge Pricing Rule Type Details.....	2830

## **Chapter XXXV: Fully-Insured Billing..... 2833**

Audit Framework for Fully-Insured Health Care Billing.....	2834
Age Based and Tier Based Pricing Rules Audit Process.....	2835
Membership Audit Process.....	2836
Person Audit Process.....	2839
Bill Group Derivation for Membership.....	2840
Account and Price Item Derivation for Membership.....	2840

State of Issue.....	2841
Membership Premium Calculation.....	2841
Repricing.....	2846
Fully Insured Billable Charge Creation.....	2847

## **Chapter XXXVI: Entity Audit..... 2849**

Audit Event Status Transition.....	2850
Prerequisites.....	2850
Entity Audit Process.....	2851
Audit Event Creation.....	2851
Audit Event Processing.....	2852
Algorithms Used in the Entity Audit Process.....	2852
C1-REAUDEVNT.....	2852
C1-AUDEVMPR.....	2853
Audit Event Type.....	2853
Audit Event Type List.....	2855
Audit Event Type.....	2856
Defining an Audit Event Type.....	2858
Associating an Algorithm with an Audit Event Type.....	2861
Adding an Element for Auditing in an Audit Event Type.....	2862
Defining a Characteristic for an Audit Event Type.....	2865
Editing an Audit Event Type.....	2866
Copying an Audit Event Type.....	2868
Deleting an Audit Event Type.....	2870
Viewing the Audit Event Type Details.....	2871
Audit Event (Used for Searching).....	2872
Search Audit Event.....	2872
Searching for an Audit Event.....	2874
Viewing the Audit Event Details.....	2875
Audit Event (Used for Viewing).....	2875
Audit Event - Main.....	2876
Audit Event.....	2876
Audit Event - Log.....	2877
Audit Event Log.....	2877
Canceling an Audit Event.....	2878
Viewing the Log of an Audit Event.....	2879

## **Appendix A: Most Commonly Used Tasks..... 2881**

Changing the Layout.....	2882
Adding a Column to the Zone.....	2882
Rearranging Columns in the Zone.....	2882
Removing a Column from the Zone.....	2882

## **Appendix B: Administration..... 2885**

UI Maps.....	2886
Creating Display UI Map for an Approval Workflow Group.....	2886
Creating Input UI Map for an Approval Workflow Group.....	2887
Feature Configurations.....	2888
Setting the C1_ACCTINFO Feature Configuration.....	2888
Setting the C1-ASOBLLNG Feature Configuration.....	2889
Setting the C1_AXENTITY Feature Configuration.....	2902
Setting the C1-BILLADJSQ Feature Configuration.....	2904
Setting the C1-BILLCYCLE Feature Configuration.....	2905

Setting the C1_CMO Feature Configuration.....	2906
Setting the C1_DIVFUNCT Feature Configuration.....	2907
Setting the C1_EXCHRATE Feature Configuration.....	2908
Setting the C1_EXP_OVRD Feature Configuration.....	2908
Setting the C1_FINTRANOP Feature Configuration.....	2909
Setting the C1_FM Feature Configuration.....	2910
Setting the C1-OFFSETREQ Feature Configuration.....	2917
Setting the C1-PAYPORTAL Feature Configuration.....	2918
Setting the C1_PERACCT Feature Configuration.....	2920
Setting the C1_PERSTYPE Feature Configuration.....	2920
Setting the C1_PER_REL Feature Configuration.....	2921
Setting the C1_PPARAM_FLG Feature Configuration.....	2922
Setting the C1_PRASNORDR Feature Configuration.....	2923
Setting the C1_PR_REC Feature Configuration.....	2924
Setting the C1-PYREQSRT Feature Configuration.....	2925
Setting the C1_RLENG Feature Configuration.....	2926
Setting the C1-TXNDMYID Feature Configuration.....	2926



# About this Document

---

This document lists and describes various features in Oracle Revenue Management and Billing which can be used in the Healthcare and Insurance domains. It describes all screens related to these features and explains how to perform various tasks through these screens.

## Intended Audience

---

This document is intended for the following audience:

- End-users
- System Administrators
- Consulting Team
- Implementation Team
- Development Team

## Organization of the Document

---

Each insurance feature is described in a separate chapter in this document. All screens related to the feature and tasks related to the screen are explained in each chapter. This document contains the following chapters:

Chapter Number	Chapter Name	Chapter Description
Chapter 1	Self-Funded Customer Management	Explains how to create customers and accounts for billing the self-funded plans.
Chapter 2	Fully-Insured Customer Management	Explains how to create customers and accounts for billing the fully-insured plans.
Chapter 3	Customer Registration	Describes how to create a person, account, policy, and policy plan through a customer registration object.
Chapter 4	Customer 360° View	Explains how to view in-depth information about the person, account, or policy in the <b>Customer 360° View</b> screen. It explains how to create sort records for bill groups and derivation and pricing parameters for bill groups. It explains how to view the pricing rules of a parent customer and the pricing rules defined for a policy of a bill group. It also explains how to define, edit, and delete the different types of pricing rules of a parent customer and bill group. In addition, it explains how to view the detailed information about the bill.
Chapter 5	Pricing Management	Explains the different concepts of the pricing model supported in the application. It explains how to define a parameter, price item, price list, tiering criterion, variance parameter, and person to person relationship type sequence. It also explains how to define pricing for a price item, how to assign a price item to a person, account, or price list, and how to assign a price list to a person or account.
Chapter 6	Division	Describes the different types of division. It also explains how to define a division.

Chapter Number	Chapter Name	Chapter Description
Chapter 7	Approval Workflow	Describes the approval workflow process and explains how to perform various tasks involved in the process. It explains how to implement the approval workflow process for an entity, such as account, person, and so on. It explains how to define an approval workflow group, approval workflow chain, approval workflow criterion type, approval workflow group chain linkage, approval workflow reasons, and approval workflow settings.
Chapter 8	Rules Engine	Describes how the rules engine function. It explains how to define, execute, and maintain business rules separately from the application code.
Chapter 9	Alternate Sequential Bill Numbers	Explains how to generate alternate sequential bill numbers which are either unique throughout the system or within the division.
Chapter 10	Transaction Feed Management	Describes the transaction feed management process and its sub-processes. It explains how to execute each sub-process. It also explains how to view the details of various transactions uploaded in the system. In addition, it explains how to create a transaction source, transaction record type, transaction aggregation rule, aggregation schedule, and disaggregation request.
Chapter 11	Upload Validated Payment Data	Explains how to upload and validate the payment records before you move them to the staging area. It also explains how to create payment events and payments using the validated payment records.
Chapter 12	Freeze Payments on Notification	Explains how the system freezes or cancels the automatic payments, voids the refund requests and cancels the refund adjustments when the review comments are received from the auto clearing house.
Chapter 13	Trial Billing	Explains how to generate trial bills before the actual bill is generated for an account. It also explains how to view the trial bills in the system.
Chapter 14	GL Account Validation	Explains how to enable the static or dynamic GL account validation feature.
Chapter 15	Upload Validated Adjustment Data	Explains how to validate and upload an adjustment data file and create adjustments through an adjustment upload request.
Chapter 16	Payment Request	Explains how to create or transfer payments through a payment request.
Chapter 17	Account Receivable Central	Explains how to use the <b>Account Receivable Central</b> screen to search for a bill which you need to offset against another bill. It explains how to perform single, mass, and cross currency offset against one or more bills. It also enables you to create a hold request, refund request, write off request, and dispute request through this screen.
Chapter 18	Offset Request	Explains how to offset the bill's outstanding amount against one or more bills through an offset request. It explains how to create the offset request types and offset requests in the system.
Chapter 19	Funding Request	Describes how to change the automatic payment amount through the funding process. It explains how to create the funding request types and funding requests in the system.

Chapter Number	Chapter Name	Chapter Description
Chapter 20	Refund/Write Off Request	Describes how to refund a payment or credit bill or bill line item and write off a debit bill or bill line item through a refund or write off request, respectively. It explains how to create the refund or write off request types and refund or write off requests in the system.
Chapter 21	Hold Request	Describes how to hold some processes and/or bills at the account or person level for a time period through a hold request. It explains how to create the hold request types and hold requests in the system.
Chapter 22	Delinquency Central	Explains how to track the overdue processes of a delinquent account through the <b>Delinquency Central</b> screen. It also explains how to create a hold request, payment arrangement, and promise to pay for a delinquent account from this screen.
Chapter 23	Upload Request	Explains how to do the following through an upload request: <ul style="list-style-type: none"> <li>• Update bill cycle of accounts</li> <li>• Update contract riders in contracts</li> <li>• Create hold requests, refund requests, write off requests, or billable charges</li> <li>• Reinstate the policies</li> <li>• Create sort records for bill groups</li> <li>• Create derivation and pricing parameters for bill groups</li> </ul>
Chapter 24	General Ledger (GL) Accounting Template	Describes how to override the distribution code used for creating FT GL entries using the <b>GL Accounting Template</b> feature. It explains how to create the GL accounting templates for each process and sub processes combination.
Chapter 25	Payment Agreement Request	Describes how to schedule payments in installments for a set of unpaid bills of an account through a payment agreement request. It explains how to create the payment agreement request types and payment agreement requests in the system.
Chapter 26	Inbound Message	Explains how to create the customer and membership inbound messages through the web services. It explains the XML format in which the customer and membership data should be available while calling the respective web service. It also explains how to create the inbound message types and how to process the inbound messages in the system.
Chapter 27	Health Insurance Policy	Describes the fully-insured and self-funded policies and their lifecycle. Explains how to create the policy types, policy person roles, contract relationship types, and source systems in the system. It explains how to create the fully-insured policies, plans, and memberships in the system. It also explains how to create the self-funded policies in the system.
Chapter 28	Upload Lockbox Payment and Remittance Advices	Explains how to upload lockbox payment and remittance advices received in the <b>Electronic Data Exchange (EDI) 820</b> format. It also explains the format in which EDI 820 flat file should be uploaded in the system.

Chapter Number	Chapter Name	Chapter Description
Chapter 29	Deferred Revenue Recognition	Describes how to recognize the deferred revenue in the system. It explains how to create a deferred revenue recognition template for each distribution code and contract type combination. It also explains how to generate the schedule for a deferred revenue recognition. In addition, it explains how to edit the deferred revenue recognition schedule.
Chapter 30	Reconciliation	Describes how to reconcile pay instructions received from the external system against the bill segments based on the account identifier, policy number, plan number, member identifier, and coverage period combination. It explains the CSV and EDI 820 file formats in which you can upload the pay instructions. It also explains how to create reconciliation types, reconciliations, discrepancy report types, and discrepancy reports in the system.
Chapter 31	Self-Funded Pricing	Explains how to create the following in the system: <ul style="list-style-type: none"> <li>• Claim, Specific Stop-Loss, Aggregate Stop-Loss, Retention Type Claim Based, Retention Type Enrollment Based, One-Time Flat Fees, Bill Period Based Recurring Flat Fees, Frequency Based Recurring Flat Fees, Ancillary, Discount, and Level-Funding pricing rule types</li> <li>• Claim, Specific Stop-Loss, Aggregate Stop-Loss, Retention Type Claim Based, Retention Type Enrollment Based, Ancillary, and Level-Funding pricing rules for the parent customers and the policies of the bill groups</li> <li>• One-Time Flat Fees, Bill Period Based Recurring Flat Fees, and Frequency Based Recurring Flat Fees pricing rules for the policies of the bill groups</li> <li>• Discount pricing rules for the parent customers</li> </ul>
Chapter 32	Self-Funded Billing	Explains the billing process for the self-funded plans.
Chapter 33	Fully-Insured Pricing	Explains how to create the following in the system: <ul style="list-style-type: none"> <li>• Age Based, Tier Based, and Pass-Through Billable Charge pricing rule types</li> <li>• Age Based and Tier Based pricing rules for the fully-insured group policy plans</li> </ul>
Chapter 34	Fully-Insured Billing	Explains how the system creates the fully insured pass-through billable charges.
Chapter 35	Entity Audit	Explains how auditors can track various actions, such as add, update, and delete for an entity.
Appendix A	Most Commonly Used Tasks	Lists and describes some of the common tasks that you may perform while using the application.
Appendix B	Administration	Describes how to create UI maps and set various feature configurations in the system.



## Conventions

---

The following conventions are used across this document:

Convention	Meaning
<b>boldface</b>	Boldface indicates graphical user interface elements associated with an action, or terms defined in the text.
<i>italic</i>	Italic indicates a document or book title.
Monospace	Monospace indicates information that an end-user needs to enter in the application.

## Related Documents

---

You can refer to the following documents:

Document Name	Description
<i>Oracle Revenue Management and Billing Version 2.8.0.0.0 Release Notes</i>	Provides a brief description about the new features, enhancements, UI and database level changes, supported platforms, framework upgrade, supported upgrades, and technology upgrade made in this release. It also highlights the discontinued features, bug fixes, and known issues in this release.
<i>ORMB - Transaction Feed Management - Batch Execution Guide</i>	Describes the sequence in which the batches must be executed while performing various tasks in the Transaction Feed Management module.
<i>Oracle Revenue Management and Billing Batch Guide</i>	Lists and describes various ORMB batches.
<i>Oracle Revenue Management and Billing Installation Guide</i>	Lists the application server pre-requisites, supported platforms, and software and hardware requirements for installing the Oracle Revenue Management and Billing application. It explains how to install the Oracle Revenue Management and Billing application.
<i>Oracle Revenue Management and Billing Quick Installation Guide</i>	Provides high-level information on how to install the Oracle Revenue Management and Billing (ORMB) application and selected additional software.
<i>Oracle Revenue Management and Billing Database Administrator's Guide</i>	Provides information about the Oracle Database Server and Client required for installing the Oracle Revenue Management and Billing database. It explains how to install database with and without demo data. It provides database configuration guidelines including recommended settings for the Oracle Exadata Database machine.
<i>Oracle Revenue Management and Billing Server Administration Guide</i>	Explains the Oracle Revenue Management and Billing (ORMB) architecture and technical know-how required for configuring and using the ORMB application. It explains how to configure and deploy web and business application servers. In addition, it explains how to monitor client machines, web and/or business application servers, and database connections.

Document Name	Description
<i>Oracle Revenue Management and Billing Security Guide</i>	Lists the security features available in the Oracle Revenue Management and Billing application. It explains how to configure security for the Oracle Revenue Management and Billing application using the default security features.

## Change Log

Revision	Last Update	Updated Section	Comments
9.1	07-07-2019	Fully-Insured Billing	Added Section
9.2	08-07-2019	Self-Funded Customer Management (formerly, known as Administrative Services Only (ASO) Customer Management)	Updated Information
		Fully-Insured Customer Management	Added Section
		Customer 360° View	Updated Information
		Self-Funded Pricing (formerly, known as Administrative Services Only (ASO) Pricing)	Added Information Related to Discount and Level Funded Pricing Rules Types
		Policy-Membership Overview	Updated Information
		Audit Event	Added Section
		Upload Validated Adjustment Data	Updated Information in the Status Transition Topics
		Payment Request	Updated Information in the Status Transition Topics
		Offset Request	Updated Information in the Status Transition Topics
		Refund/Write Off Request	Updated Information in the Status Transition Topics
		Hold Request	Updated Information in the Status Transition Topics
		Upload Request	Updated Information in the Status Transition Topics
		General Ledger (GL) Accounting Template	Updated Information in the Status Transition Topics
Payment Agreement Request	Updated Information in the Status Transition Topics		

Revision	Last Update	Updated Section	Comments
		Funding Request	Updated Information in the Status Transition Topics
		Fully-Insured Billing	Added Section
9.3	15-07-2019	Inbound Message	Added Sections related to Health Care Inbound Message
9.4	16-07-2019	Inbound Message	Updated Information
9.5	18-07-2019	Inbound Message	Updated Information
9.6	19-07-2019	Inbound Message	Updated Information
9.7	26-07-2019	Self-Funded Pricing	Added Information
		Fully-Insured Pricing	Added Information
		Inbound Message	Updated Information
		Self-Funded Customer Management	Added Information
9.8	06-08-2019	Pricing Management	Updated Information
		Inbound Message	Updated Information
9.9	21-08-2019	Inbound Message	Updated Information
		Transaction Feed Management	Updated Information
		Setting the C1-ASOBLLNG Feature Configuration	Added Information
9.10	19-09-2019	Audit Event	Updated Information
		Inbound Message	Updated Information
		Self-Funded Pricing	Added Section
		Policy	Updated Information
9.11	26-09-2019	Division	Added Information
9.12	30-10-2019	Inbound Message	Updated Information
		Health Insurance Policy (Formerly known as Policy-Membership Overview)	Updated Information
		Customer Registration	Added Information
		Price Item	Added Information
		Offset Request	Updated Information

<b>Revision</b>	<b>Last Update</b>	<b>Updated Section</b>	<b>Comments</b>
9.13	13-11-2019	Health Insurance Policy	Updated Information
		Offset Request	Updated Information
9.14	23-11-2019	Health Insurance Policy	Updated Information
		Fully-Insured Billing	Updated Information
9.15	30-11-2019	Upload Validated Adjustment Data	Updated Information
		Health Insurance Policy	Updated Information
		Fully-Insured Billing	Updated Information
9.16	12-12-2019	Health Insurance Policy	Updated Information
		Fully-Insured Billing	Updated Information
9.17	28-01-2020	Offset Request	Updated Information
9.18	12-02-2020	Health Insurance Policy	Updated Information
9.19	18-08-2020	Upload Validated Adjustment Data	Updated Information

---

# Chapter 1

---

## Self-Funded Customer Management

---

### Topics:

- [Self-Funded Entities](#)

Self-funded health care, also known as Administrative Services Only (ASO), is a self insurance arrangement whereby an employer provides health or disability benefits to employees using the company's own funds. In self-funded health plan, employers (usually larger) operate their own health plan. However, in the fully-insured plan, the employer contracts an insurance company to cover the employees and dependents. Employers choose to self-insure because it allows them to save the profit margin that an insurance company adds to its premium for a fully-insured plan. However, self-insuring exposes the company to much larger risk in the event that more claims than expected must be paid.

Oracle Revenue Management and Billing (ORMB) supports the following types of self-funding approach:

- **Fully Self-Funded** - In the fully self-funded approach, the employer retains all the risk and bears the claim costs irrespective of any limit.
- **Partially Self-Funded** - In the partially self-funded approach, the employer purchases reinsurance or stop loss coverage to pass the risk to insurance company.

The system enables you to create customers and accounts for the self-funded health care business. This chapter explains how to create different entities involved in the self-funded health care business.

For more information on...	See...
Self-Funded Entities	<a href="#">Self-Funded Entities</a> on page 54

## Self-Funded Entities

The following figure graphically represents the different entities involved in the self-funded health care business:

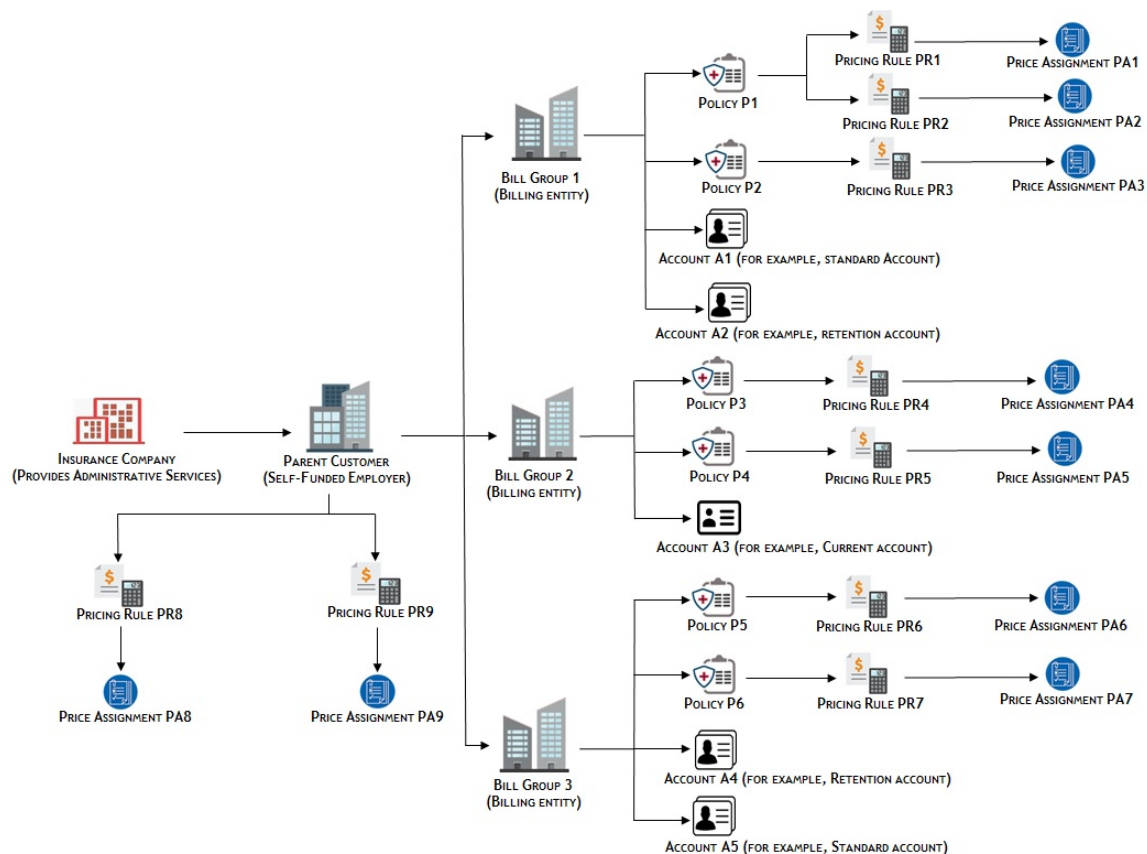

For more information on...	See...
<b>Parent Customer</b>	<a href="#">Parent Customer</a> on page 54
<b>Bill Group</b>	<a href="#">Bill Groups</a> on page 55
<b>Bill Group's Account</b>	<a href="#">Bill Group's Account</a> on page 55
<b>Self-Funded Policy</b>	<a href="#">Self-Funded Policy</a> on page 56
<b>Price Items</b>	<a href="#">Price Items</a> on page 56
<b>Pricing Rule Types</b>	<a href="#">Pricing Rule Types</a> on page 56
<b>Pricing Rules</b>	<a href="#">Pricing Rules</a> on page 57
<b>Price Assignments</b>	<a href="#">Price Assignments</a> on page 58

### Parent Customer

The self-funded employers must be defined as parent customers in the system. You can define a person as the parent customer by setting its person type to **Parent Customer**. You can create a parent customer through a customer registration object or a health care inbound message.

## Bill Groups

The system allows you to define one or more bill groups for a parent customer. The claim, enrollment, and ancillary transactions of the employees are billed to a bill group. Each bill group will handle the claim, enrollment, and ancillary transactions of employees based on the employee attributes, such as location, employment status, employment department, and so on. The system allows you to define the derivation and pricing parameters, such as source system, parameter 1, parameter 2, parameter 3, and parameter 4 for a bill group. These parameters are used to derive the bill group against which the claim, enrollment, and ancillary charges should be billed in the system. The derived bill group is also used for billing the claim based fees, specific stop-loss credits, aggregate stop-loss credits, discount, and level-funding charges.

You can define a person as the bill group by setting its person type to **Bill Group**. The bill groups should be defined as the child persons of the parent customer (i.e. self-funded employer) using the relationship type which is specified in the **Person Relationship Type** option type of the **C1-ASOBLNG** feature configuration. You can create a bill group through a customer registration object or a health care inbound message.

### Related Topics

For more information on...	See...
Bill Group Derivation and Pricing Parameters	<a href="#">Bill Group Derivation and Pricing Parameters</a> on page 2722
How to setup the <b>C1-ASOBLNG</b> feature configuration	<a href="#">Setting the C1-ASOBLNG Feature Configuration</a> on page 2889

## Bill Group's Account

The claim charges, specific stop-loss credits, aggregate stop-loss credits, claim based fees, enrollment based fees, ancillary charges, discount, and level-funding charges are billed to the bill group's account. Therefore, every bill group should have at least one account in the system. You can create multiple accounts for a bill group. You can create an account for a bill group through a customer registration object or a health care inbound message.

Depending on the employer's preference, the claim charges, specific stop-loss credits, aggregate stop-loss credits, claim based fees, enrollment based fees, ancillary charges, discount, and level-funding charges can be billed on the same or different accounts of the bill group. The system enables you to create different types of accounts (such as, standard and retention) for a bill group. You can specify the type of account by defining the **Invoice Type (C1INVTYP)** characteristic for the account.

**Note:** At present, we have not shipped any predefined values for the **Invoice Type (C1INVTYP)** characteristic type. You must define the predefined characteristic values as per the business requirements.

You can also set the priority for an account based on the invoice type while specifying the billing account information for a price item in a pricing rule type. For example,

Price Item	Priority	Invoice Type	Account
P1	10	Standard	A1
	20	Retention	A2
P2	10	Retention	A2
	20	Standard	A1

Now, when a claim transaction is mapped to P1, the system checks whether an account where the **Invoice Type (C1INVTYP)** characteristic type is set to **Standard** exists for the bill group. If so, it considers the standard account (A1) of the bill group for billing. However, if an account where the **Invoice Type (C1INVTYP)** characteristic type is set to **Standard** does not exist for the bill group, the system checks whether an account where the **Invoice Type (C1INVTYP)** characteristic type is set to **Retention** exists for the bill group. If so, it considers the retention account (A2) of the bill

group for billing. If an account where the **Invoice Type (C1INVTYP)** characteristic type is set to **Retention** does not exist for the bill group, the status of the transaction is changed to **Error**.

Similarly, when a claim transaction is mapped to P2, the system considers the account of the bill group which is available based on the priority. The system derives the billing account for only those price items for which the effective pricing rule is derived.

The system searches the account of the bill group based on the priority only when the **Invoice Type Characteristic Type** option type of the **C1-ASOBLNG** feature configuration is set to **C1INVTYP**.

### Related Topics

For more information on...	See...
How to setup the <b>C1-ASOBLNG</b> feature configuration	<a href="#">Setting the C1-ASOBLNG Feature Configuration</a> on page 2889

## Self-Funded Policy

You can create a self-funded policy using a policy type where the policy category is set to **Self-Funded**. You can create a self-funded policy through a customer registration object or a health care inbound message. If the self-funded policy information is given for a bill group in a health care inbound message, the system does the following:

- Associates the bill group with the policy using the policy person role which is specified in the **Bill Group Policy Person Role** option type of the **C1-ASOBLNG** feature configuration
- Associates the parent customer with the policy using the policy person role which is specified in the **Parent Customer Policy Person Role** option type of the **C1-ASOBLNG** feature configuration

## Price Items

Each service offered in the self-funded plan should be defined as a price item in the system. You must add the price item in a pricing rule type. The system then enables you to create a pricing rule for a price item using the respective pricing rule type.

You can define a price item and associate the required parameters with the price item from the user interface. You can use the price item parameters for defining multi parameter based pricing or for aggregating the transactions.

## Pricing Rule Types

You can create a pricing rule using the respective pricing rule type. The system enables you to create pricing rule types of the following categories for the self-funded plan from the user interface:

Pricing Rule Type	Pricing Rule Type Category	Sample Shipped with the Product
Claim	Claim	CLAIM
Retention Type Claim Based	Retention Type Claim Based	RETCLMBSD
Discount Share	Discount Arrangement	DISSHARE
Discount Guarantee	Discount Arrangement	DISGUAR
One-Time Flat Fees	Flat Fees	ONETIMEFLATFEES
Bill Period Based Recurring Flat Fees	Flat Fees	RECFLATFEES_BP
Frequency Based Recurring Flat Fees	Flat Fees	RECFLATFEES_FREQ
Retention Type Enrollment Based	Retention Type Enrollment Based	RETENRLBSD



Pricing Rule Type	Pricing Rule Type Category	Sample Shipped with the Product
Ancillary	Ancillary	ANCILLARY
Specific Stop-Loss	Specific Stop-Loss	SSL
Aggregate Stop-Loss	Aggregate Stop-Loss	ASL
Enrollment Based Premium	Level Funded	LVLNRLPRE
Flat Rate Based Premium	Level Funded	LVLFLATPRE

## Pricing Rules

The self-funded plan may offer various services to the employer, such as claim administration, reinsurance or stop-loss, discount or level funding arrangement, and so on. Oracle Revenue Management and Billing enables you to define pricing rules for various services offered in the self-funded plan. The below table lists the pricing rules which you can define for the following services offered in the self-funded plan:

Service	Pricing Rule	Created for....
Claim Administration	Claim	Parent Customer
Claim Administration	Claim	Bill Group's Policy where the Parent Customer is the Policy Holder
Claim Administration	Retention Type Claim Based	Parent Customer
Claim Administration	Retention Type Claim Based	Bill Group's Policy where the Parent Customer is the Policy Holder
Claim Administration	Discount Share	Parent Customer
Claim Administration	Discount Guarantee	Parent Customer
Claim Administration	One-Time Flat Fees	Bill Group's Policy where the Parent Customer is the Policy Holder
Claim Administration	Bill Period Based Recurring Flat Fees	Bill Group's Policy where the Parent Customer is the Policy Holder
Claim Administration	Frequency Based Recurring Flat Fees	Bill Group's Policy where the Parent Customer is the Policy Holder
Enrollment	Retention Type Enrollment Based	Parent Customer
Enrollment	Retention Type Enrollment Based	Bill Group's Policy where the Parent Customer is the Policy Holder
Ancillary, such as Laboratory, Radiology, Pharmacy, Physical Therapy, or Preventive Care	Ancillary	Parent Customer
Ancillary, such as Laboratory, Radiology, Pharmacy, Physical Therapy, or Preventive Care	Ancillary	Bill Group's Policy where the Parent Customer is the Policy Holder
Stop-Loss	Specific Stop-Loss	Parent Customer
Stop-Loss	Specific Stop-Loss	Bill Group's Policy where the Parent Customer is the Policy Holder
Stop-Loss	Aggregate Stop-Loss	Parent Customer

Service	Pricing Rule	Created for....
Stop-Loss	Aggregate Stop-Loss	Bill Group's Policy where the Parent Customer is the Policy Holder
Level Funding Arrangement	Enrollment Based Premium	Parent Customer
Level Funding Arrangement	Enrollment Based Premium	Bill Group's Policy where the Parent Customer is the Policy Holder
Level Funding Arrangement	Flat Rate Based Premium	Parent Customer
Level Funding Arrangement	Flat Rate Based Premium	Bill Group's Policy where the Parent Customer is the Policy Holder

You can create the above mentioned self-funded pricing rules for a parent customer or for the policy of the bill group from the user interface and not through a health care inbound message.

The system creates a price assignment for each pricing rule. In case of the retention type claim and enrollment based pricing rules, the system creates multiple price assignments when different claim based or enrollment based fee is offered for employees with different set of employee attributes.

The system first searches for the pricing rule of a price item (i.e. service) at the bill group level. If the effective pricing rule for a price item is available at the bill group level, the system uses it for deriving the price assignment. However, if the effective pricing rule for a price item is not available at the bill group level, the system searches for the pricing rule of a price item at the parent customer level. If the effective pricing rule for a price item is available at the parent customer level, the system uses it for deriving the price assignment. However, if the effective pricing rule for a price item is not available at the bill group or parent customer level, the system does not consider the respective price item for billing.

## Price Assignments

The system creates a price assignment for each self-funded pricing rule. In case of the retention type claim and enrollment based pricing rules, the system creates multiple price assignments when different claim based or enrollment based fee is offered for employees with different set of employee attributes.

The system automatically creates a price assignment whenever you create a self-funded pricing rule. The system creates the price assignment in a price list and assigns the price list to the parent customer or bill group. The system creates multiple price assignments when you define a pricing rule for a policy of a bill group using a pricing group.

### Related Topics

For more information on...	See...
Pricing Group	<a href="#">Pricing Group</a> on page 2333

---

# Chapter

# 2

---

## Fully-Insured Customer Management

---

### Topics:

- [Fully-Insured Entities](#)

A fully-insured health plan is the traditional way to structure an employer-sponsored health plan. In the fully-insured plan, the employer contracts an insurance company to cover the employees and dependents. The employer pays a premium to the insurance carrier. The premium rates are fixed for a year, based on the number of employees enrolled in the plan each month. The monthly premium changes during the year when the number of enrolled employees in the plan changes. The insurance carrier collects the premiums and pays the health care claims based on the coverage benefits outlined in the policy. The covered persons (i.e. employees and dependents) are responsible to pay any deductible amounts or co-payments required for covered services under the policy.

The system enables you to create customers and accounts for the fully-insured health care business. This chapter explains how to create different entities involved in the fully-insured health care business.

### Related Topics

For more information on...	See...
<b>Fully-Insured Entities</b>	<a href="#">Fully-Insured Entities</a> on page 60

## Fully-Insured Entities

The following figure graphically represents the different entities involved in the fully-insured health care business:

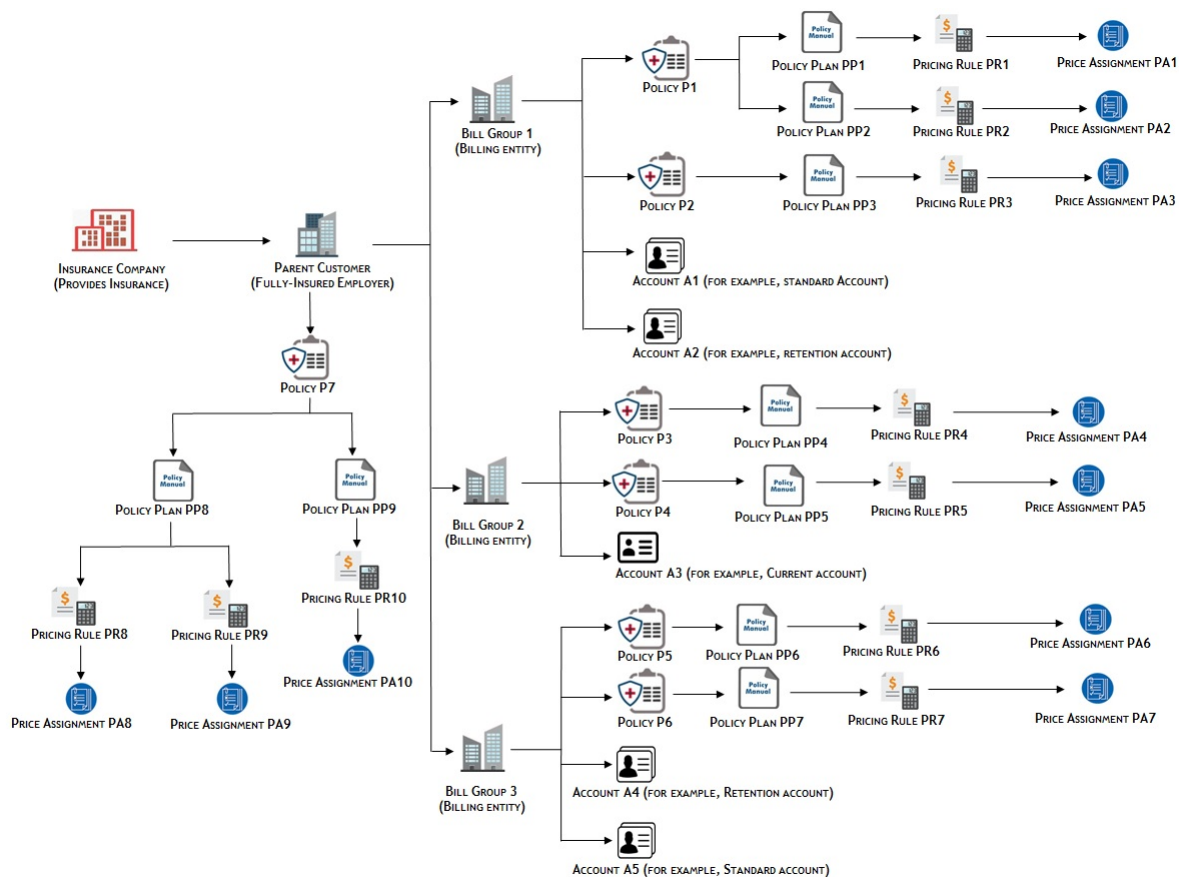

### Related Topics

For more information on...	See...
<b>Parent Customer</b>	<a href="#">Parent Customer</a> on page 61
<b>Bill Groups</b>	<a href="#">Bill Groups</a> on page 61
<b>Bill Group's Account</b>	<a href="#">Bill Group's Account</a> on page 61
<b>Fully-Insured Policy</b>	<a href="#">Fully-Insured Policy</a> on page 62
<b>Policy Plans</b>	<a href="#">Policy Plans</a> on page 62
<b>Price Items</b>	<a href="#">Price Items</a> on page 63
<b>Pricing Rule Types</b>	<a href="#">Pricing Rule Types</a> on page 63
<b>Pricing Rules</b>	<a href="#">Pricing Rules</a> on page 63
<b>Price Assignments</b>	<a href="#">Price Assignments</a> on page 63

## Parent Customer

The fully-insured employers must be defined as parent customers in the system. You can define a person as the parent customer by setting its person type to **Parent Customer**. You can create a parent customer through a customer registration object or a health care inbound message.

## Bill Groups

The system allows you to define one or more bill groups for a parent customer. The membership premium of the employees are billed to a bill group. Each bill group will handle the membership premium of employees based on the employee attributes, such as location, employment status, employment department, and so on. The system allows you to define the derivation and pricing parameters, such as source system, parameter 1, parameter 2, parameter 3, and parameter 4 for a bill group. These parameters are used to derive the bill group against which the membership premium should be billed in the system. You can define a person as the bill group by setting its person type to **Bill Group**. The bill groups should be defined as the child persons of the parent customer (i.e. fully-insured employer) using the relationship type which is specified in the **Person Relationship Type** option type of the **C1-ASOBLNG** feature configuration. You can create a bill group through a customer registration object or a health care inbound message.

### Related Topics

For more information on...	See...
Bill Group Derivation and Pricing Parameters	<a href="#">Bill Group Derivation and Pricing Parameters</a> on page 2722
How to setup the <b>C1-ASOBLNG</b> feature configuration	<a href="#">Setting the C1-ASOBLNG Feature Configuration</a> on page 2889

## Bill Group's Account

The membership premium of employees are billed to the bill group's account. Therefore, every bill group should have at least one account in the system. You can create multiple accounts for a bill group. You can create an account for a bill group through a customer registration object or a health care inbound message.

Depending on the employer's preference, the charges for one or more membership and price item combinations can be billed on the same or different accounts of the bill group. The system enables you to create different types of accounts (such as, MEDCARE1 and MEDCARE2) for a bill group. You can specify the type of account by defining the **Invoice Type (C1INVTYP)** characteristic for the account.

**Note:** At present, we have not shipped any predefined values for the **Invoice Type (C1INVTYP)** characteristic type. You must define the predefined characteristic values as per the business requirements.

You can also set the priority for an account based on the invoice type while specifying the billing account information for a price item in a pricing rule type. For example,

Price Item	Priority	Invoice Type	Account
P1	10	MEDCARE1	A1
	20	MEDCARE2	A2
P2	10	MEDCARE2	A2
	20	MEDCARE1	A1

Now, when the effective pricing rule is derived for P1 on the policy plan, the system checks whether an account where the **Invoice Type (C1INVTYP)** characteristic type is set to **MEDCARE1** exists for the bill group. If so, it considers the account (A1) of the bill group for billing. However, if an account where the **Invoice Type (C1INVTYP)** characteristic type is set to **MEDCARE1** does not exist for the bill group, the system checks whether an account where the **Invoice**

**Type (C1INVTYP)** characteristic type is set to **MEDCARE2** exists for the bill group. If so, it considers the account (A2) of the bill group for billing. If an account where the **Invoice Type (C1INVTYP)** characteristic type is set to **MEDCARE2** does not exist for the bill group, the status of the record in the **CI\_REPRC\_ENTITY\_DTL** table is set to **Error (E)**.

Similarly, when the effective pricing rule is derived for P2 on the policy plan, the system considers the account of the bill group which is available based on the priority. The system derives the billing account for only those price items for which the effective pricing rule is derived.

The system searches the account of the bill group based on the priority only when the **Invoice Type Characteristic Type** option type of the **C1-ASOBLNG** feature configuration is set to **C1INVTYP**.

### Related Topics

For more information on...	See...
How to setup the <b>C1-ASOBLNG</b> feature configuration	<a href="#">Setting the C1-ASOBLNG Feature Configuration</a> on page 2889

## Fully-Insured Policy

You can create a fully-insured policy using a policy type where the policy category is set to **Fully-Insured Group**. You can create a fully-insured policy through a customer registration object or a health care inbound message. If the fully-insured policy information is given for a bill group in a health care inbound message, the system does the following:

- Associates the bill group with the policy using the policy person role which is specified in the **Bill Group Policy Person Role** option type of the **C1-ASOBLNG** feature configuration
- Associates the parent customer with the policy using the policy person role which is specified in the **Parent Customer Policy Person Role** option type of the **C1-ASOBLNG** feature configuration

However, if the fully-insured policy information is given for a parent customer in a health care inbound message, the system does the following:

- Associates the parent customer with the policy using the policy person role which is specified in the **Parent Customer Policy Person Role** option type of the **C1-ASOBLNG** feature configuration

**Note:** At present, the **Fully-Insured Individual** policy category is not yet supported in the system.

## Policy Plans

A fully insured group policy may cover various plans for medical, dental, or disability benefits. You can subscribe a person for one or more policy plans within or across policies. The system creates one membership for each person who is subscribed to the policy plan. You can then add dependent members in each membership whenever required.

While creating a policy plan, you need to specify either a price item or at least one pricing rule type. The price item given in the policy plan is used to create a pass-through billable charge for pre-calculated premium amount which is received in a membership inbound message.

Alternatively, you can associate a pricing rule type with a policy plan. You can only associate a pricing rule type where the pricing rule type category is set to **Age Based**, **Tier Based**, or **Pass-Through Billable Charge**. If you associate an age based pricing rule type with the policy plan, the system creates the SQI based billable charge whenever the membership premium is calculated for eligible members. If you associate a tier based pricing rule type with the policy plan, the system creates the SQI based billable charge whenever the premium is calculated for membership. However, if you associate a pass-through billable charge pricing rule type with the policy plan, the system creates an SQI based billable charge using the pass-through billable charge pricing rule type whenever the price item information is given, but the account information is not given in a health care inbound message. Note that if both the price item and account details are given in the billable charge information, the system directly creates the SQI based billable charge for the pre-calculated premium and does not refer the pass-through billable charge pricing rule type which is associated with the policy plan.

## Price Items

Each service offered in the fully-insured plan should be defined as a price item in the system. You can define a price item from the user interface. You must add the price item in a pricing rule type. The system then enables you to create a pricing rule for a price item using the respective pricing rule type.

## Pricing Rule Types

You can create a pricing rule using the respective pricing rule type. The system enables you to create pricing rule types of the following categories for the fully-insured plan through a health care inbound message:

Pricing Rule Type	Pricing Rule Type Category	Sample Shipped with the Product
Age Based	Age Based	AGE_BASED
Tier Based	Tier Based	TIER_BASED
Pass-Through Billable Charge	Pass-Through Billable Charge	FI_PASSTBC

**Note:** You cannot define a pricing rule using a pricing rule type where the pricing rule type category is set to **Pass-Through Billable Charge**.

## Pricing Rules

The fully-insured plan may offer various services to the employer, such as medical insurance, dental insurance, vision care, life insurance, short-term and long-term disability benefits, and so on. Oracle Revenue Management and Billing enables you to define pricing rules for various services offered in the fully-insured plan. The below table lists the pricing rules which you can define for the following services offered in the fully-insured plan:

Service	Pricing Rule	Created for....
Medical Insurance, Dental Insurance, Vision Care, Life Insurance, Short-Term and Long-Term Disability Benefits, etc.	Age Based	Fully-Insured Policy Plan
	Tier Based	Fully-Insured Policy Plan

You can create the above mentioned pricing rules for the fully-insured policy plans through a health care inbound message and not from the user interface. The system creates a price assignment for each pricing rule. In the age based pricing rules, you can define different premium fee for employees who belong different age band. You can also offer different premium fee for the employees with the same age band, but with the different set of attributes. The system also enables you to charge additional fee for the eligible member based on certain modifiers. For example, you can charge additional fee when the eligible member is alcoholic and/or consumes tobacco. However, in the tier based pricing rules, you can define different premium fee for employees who belong to different membership tier, such as Employee (E), Employee + Spouse (ES), Employee + Spouse + Children (F), and so on.

The system searches for the pricing rule of a price item (i.e. service) on the policy plan to which the membership belongs. If the effective pricing rule for a price item is not available on the policy plan, the system does not consider the respective price item for billing.

## Price Assignments

The system creates a price assignment for each fully-insured pricing rule. If different premium fee is defined for employees with different set of employee attributes, then the system creates a separate price component for each set of employee attributes. If the modifiers are used in the age based pricing rule, the system creates a price component for each modifier. In the price component, the age band or tier band parameter, the employee attributes, and modifiers are used to define the pricing eligibility criteria. Once the age based or tier based pricing rule is defined for a policy plan, the system creates a price item pricing and price list, and then assigns the price item pricing to the price list.





---

# Chapter

# 3

---

## Customer Registration

---

### Topics:

- [Customer Registration \(Without Approval\) Status Transition](#)
- [Customer Registration \(With Approval\) Status Transition](#)
- [Customer Registration Template](#)
- [Customer Registration Type](#)
- [Customer Registration \(Used for Searching\)](#)
- [Customer Registration \(Used for Viewing\)](#)

Until now, you were able to create person, account, policy, and policy plan from the different screens. Now, ORMB provides the ability to create a person, multiple accounts for the person, multiple policies for the person, and multiple policy plans for the policy from the same user interface. A new object named **Customer Registration** is introduced in this release. Through a customer registration object, you can create person, accounts, policies, and policy plans at the same time from the same interface. Before creating a customer registration object, you need to create the following:

- Customer Registration Template
- Customer Registration Type

While creating a customer registration object, you need to specify the following:

- A customer registration type using which the customer registration object should be created
- A source system from the customer information is received
- A type of person that you want to create through the customer registration object

Once you specify the above details, the **Customer Registration** screen appears with a set of pages and sections which are added in the respective person template. The default values for the fields, characteristic types, identifier types, and phone types are shown as specified in the person template. In addition, the field values, characteristic types, characteristic values, identifier types, identifier values, phone types, and phone numbers are disabled as specified in the person template. On the Accounts page, you can view one row for each account template which is added in the customer registration type. You can then edit the row and thereby create an account for the person. You can create multiple accounts for the person using the same or different template.

#### Note:

You cannot create sort records and derivation and pricing parameters for the bill group from the **Customer Registrations** screen. You can only create these from the **Customer 360° Information** screen or using the healthcare inbound message.

The system creates effective dated address using the address business object which is specified in the customer registration type. By default, the account override address is effective from the date when the customer registration object is created in the system.

On the **Policies** page, you can view one row for each policy template which is added in the customer registration type. You can then edit the row and thereby

create a policy for the person. You can create multiple policies for the person using the same or different template. On clicking the **Add** icon corresponding to the policy row, you can view one row for each policy plan template which is added in the customer registration type. You can then edit the row and thereby create a policy plan for the policy.

On clicking the **View/Edit** icon or the **Add New Account** button in the **Accounts** page, the **Customer Registration - Add Account** screen appears with a set of pages and sections which are added in the respective account template. The default values for the fields, characteristic types, and identifier types are shown as specified in the account template. In addition, the field values, characteristic types, characteristic values, identifier types, and identifier values are disabled as specified in the account template.

On clicking the **View/Edit** icon or the **Add New Policy** button in the **Policies** page, you need to specify a policy type. The policy type indicates the category to which the policy belongs (i.e. whether it is Self Funded, Fully-Insured Group, or Fully-Insured Individual) and the policy business object using which the policy should be created. Once you specify a policy type, the **Policy** screen appears with a set of sections which are added in the respective policy template. The default values for the fields and characteristic types are shown as specified in the policy template. In addition, the field values, characteristic types, and characteristic values are disabled as specified in the policy template. You can create one or more policies for the person using the same or different policy type.

On clicking the **View/Edit** icon or the **Add New Plan** button corresponding to a policy plan row in the **Policies** page, the **Plan** screen appears with a set of sections which are added in the respective policy plan template. The default values for the fields and characteristic types are shown as specified in the policy plan template. In addition, the field values, characteristic types, and characteristic values are disabled as specified in the policy plan template.

You can save the person, account, policy, and policy plan details as and when you are entering the data by clicking the **Save as Draft** button. On clicking the **Save as Draft** button, the system creates a customer registration object in the Draft status. The status of the policies which are created through the customer registration object is set to Pending. Once the person, account, policy, and policy plan details are specified, you can click the **Validate and Save** button. The system then validates the information. You can edit, delete, or submit a customer registration object when it is in the **Draft** status. On submitting a customer registration object, the person, accounts, policies, and policy plans are created in the system. Finally, the status of the customer registration object is changed to the following depending on the type of person:

Person Type	Status
Parent Customer	Parent Customer Approved
Bill Group	Bill Group Approved
Any Other Person Type Other Than Parent Customer and Bill Group	Complete

You can optionally configure the approval process for the customer registration. If the **Approval Required** option is selected in the customer registration type, the status of the customer registration object is changed to **Approval In Progress** on submitting it. A To Do using the approval To Do type is created and assigned to the users with the approval To Do role. The approver can

then review the customer registration object and accordingly approve, reject, or request the submitter to resubmit the customer registration object for approval. On approving a customer registration object, the person, accounts, policies, and policy plans are created in the system. Finally, the status of the customer registration object is changed to the following depending on the type of person:

Person Type	Status
Parent Customer	Parent Customer Approved
Bill Group	Bill Group Approved
Any Other Person Type Other Than Parent Customer and Bill Group	Complete

If the approver rejects a customer registration object due to some reason, the status of the customer registration object is changed to **Rejected**. However, if the approver requests the submitter to resubmit a customer registration object for approval after making the required changes, the status of the customer registration object is changed to **Draft**. The submitter can then make the required changes and resubmit the customer registration object for approval.

The system provides the following two options while defining a customer registration type:

- Manual Billing Hierarchy and Pricing**- Used when you want to inform the user to create the billing hierarchy and pricing for the parent customer manually. In other words, you want the user to create the required bill groups for the parent customer, the bill group's accounts, pricing rules, bill group sorting information, and bill group derivation and pricing parameters. If this option is selected, a To Do is created using the **Billing Hierarchy and Pricing To Do** type and assigned to the users with the **Billing Hierarchy and Pricing To Do** role. This feature can be used only for customer registration objects where the person type is set to **Parent Customer**. Once the billing hierarchy and pricing is created for the parent customer, the user must complete the corresponding To Do which is created using the **Billing Hierarchy and Pricing To Do** type. On executing the **Customer Registration Monitor (C1-CUSRG)** batch, the system considers all customer registration objects which are in the **Parent Customer Approved** or **Pending Pricing Correction** status. It checks whether the corresponding To Do (if any) created using the **Billing Hierarchy and Pricing To Do** type is completed. If so, it changes the status of the customer registration object to the following depending on whether the **Final Approval Required** option is selected:

Final Approval Required (Yes or No)	Status
Yes	Pending Final Approval
No	Complete

- Final Approval Required**- Used to indicate whether the final approval is required once the approver at the first level approves the customer registration object. Ideally, the final approval is required when the **Manual Billing Hierarchy and Pricing** option is selected. This ensures that the information related to the following entities is created and verified before the customer registration object moves to the **Complete** status:
  - Bill Group

- Bill Group's Accounts
- Bill Group's Sorting Records
- Bill Group's Derivation and Pricing Parameters
- Pricing Rules for the Policy Plans

If this option is selected, a To Do is created using the **Final Approval To Do** type and assigned to the users with the **Final Approval To Do** role. This feature can be used only for customer registration objects where the person type is set to **Parent Customer**. Once the user with the **Final Approval To Do** role approves the customer registration object, the status of the customer registration object is changed to **Complete**.

If the approver requests the submitter to resubmit a customer registration object for approval, the status of the customer registration object is changed to **Pending Pricing Correction**.

**Note:** The system enables you to create maximum 10 accounts and 5 policies for a person and maximum 10 policy plans for a policy through a customer registration object from the user interface.

Once the status of a customer registration object is changed to **Complete** or **Bill Group Approved**, the system changes the status of the policies created through the customer registration object to **In Force/Active**. In addition, the status of the pricing rules which are created for such policies' policy plans is set to **Active**.

You can also create a customer registration object using the **File Upload Interface** utility through an inbound message. On creating an inbound message using the **File Upload Interface** utility, the status of the inbound message is set to **Pending**. Once the inbound message is processed, a customer registration object is created in the following status depending on the person type:

Person Type	Status
Parent Customer	Complete
Bill Group	Bill Group Approved
Any Other Person Type Other Than Parent Customer and Bill Group	Complete

**Note:** The above status transition is mentioned based on the assumption that the data uploaded through the **File Upload Interface** utility will be pre-approved and does not require any approval in the system.

At present, only the XML format is supported for creating a customer registration object using the File Upload Interface utility through an inbound message. To implement the Customer Registration feature, the following new screens are introduced in this release:

- Customer Registration Template
- Customer Registration Type
- Customer Registration

## Customer Registration (Without Approval) Status Transition

The following figure graphically indicates how a customer registration moves from one status to another when the approval process is not configured in the respective customer registration type:

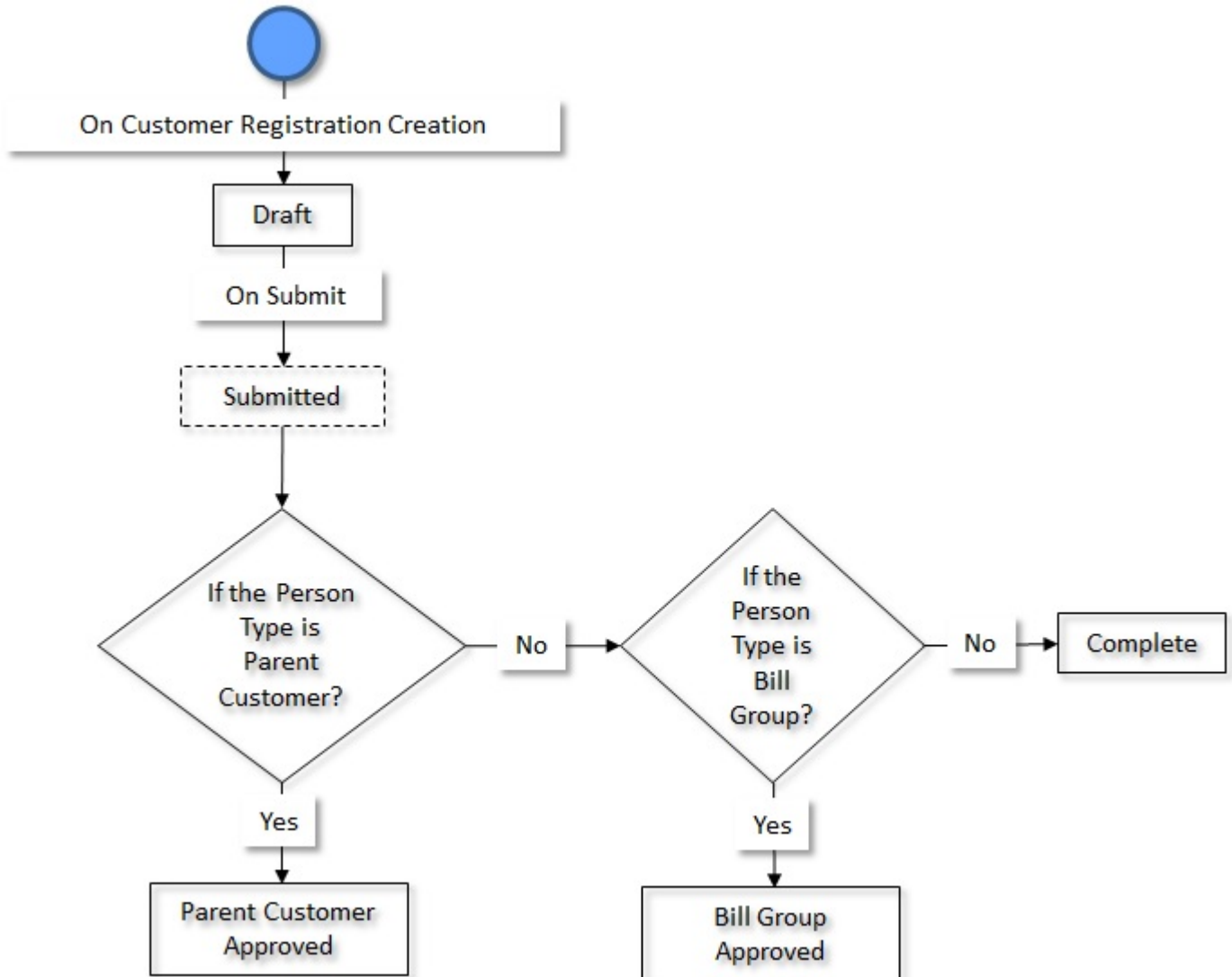

## Customer Registration (With Approval) Status Transition

The following figure graphically indicates how a customer registration moves from one status to another when the approval process is configured in the respective customer registration type:

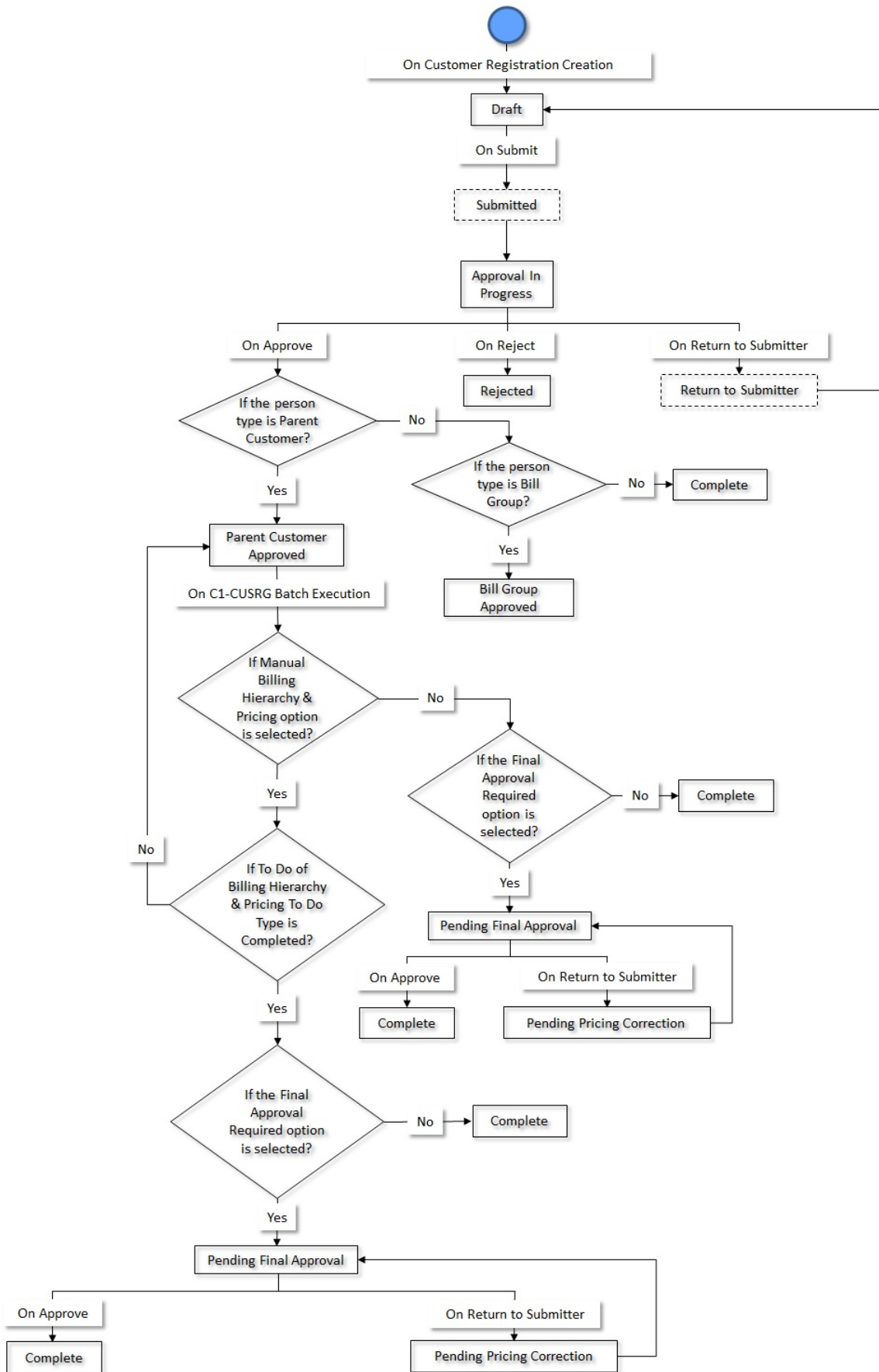

## Customer Registration Template

A customer registration template encapsulates the following information:

- List of pages that should appear when you create a person, account, policy, or policy plan using the respective customer registration template
- List of sections that should appear in each page
- Field or characteristic attributes, such as:
  - Default value for a field or characteristic type
  - Default value for a person or account identifier type or phone type
  - Primary identifier type for a person or account
  - Mandatory field in each section
  - Enable or disable the field value, identifier type, identifier value, characteristic type, characteristic value, phone type, or phone number

You can create multiple customer registration templates for person, account, policy and policy plan. Depending on whether you are creating a customer registration template for person, account, policy or policy plan, you can include the following pages and define field or characteristic attributes for the following sections:

Template Category	Template Page	Template Section
Person	Accounts	-
	Contact Information	Person Address
		Person Email
	Deal Information	Deal - Main
	Main	Person Identifiers
		Person Main
		Person Names
		Person Phones
	Person Characteristics	Person Characteristics
	Person Hierarchy	Person Hierarchy – Characteristics
		Person Hierarchy – Main
	Policies	Policies
		Parent Policies
	Registration Characteristics	Customer Registration Characteristics

Template Category	Template Page	Template Section
Account	Auto Pay	Account Autopay
	Account Characteristics	Account Characteristics
	Main	Account Identifiers
		Account Information
	Persons	Main
		Account Address Override Information
		Bill Routing
Credit Ratings	Credit Rating	
Policy	Policy – Main	Policy Characteristics
		Policy Main
		Policy Persons
Policy Plan	Plan	Plan - Characteristics
		Plan - Main

### **Related Topics**

For more information on...	See...
How to edit a customer registration template	<a href="#">Editing a Customer Registration Template</a> on page 81
How to copy a customer registration template	<a href="#">Copying a Customer Registration Template</a> on page 84
How to delete a customer registration template	<a href="#">Deleting a Customer Registration Template</a> on page 87
How to view the details of a customer registration template	<a href="#">Viewing the Customer Registration Template Details</a> on page 77

## **Search Customer Registration Template**

The **Search Customer Registration Template** zone allows you to search for a customer registration template using various search criteria. It contains the following two sections:





- **Search Criteria** - The **Search Criteria** section contains the following fields:



Field Name	Field Description	Mandatory (Yes or No)						
Search By	Used to indicate whether you want to search for a customer registration template using the banking or healthcare template details. The valid values are: <ul style="list-style-type: none"> <li>Banking Template</li> <li>Healthcare Template</li> </ul> <div style="border: 1px solid black; padding: 2px; margin-top: 5px;"><b>Note:</b> By default, the <b>Banking Template</b> option is selected.</div>	Yes						
Template	Used to search customer registration template with a particular name.	No						
Description	Used to search the customer registration template with a particular description.	No						
Template Category	<table border="1" style="width: 100%; border-collapse: collapse;"> <thead> <tr> <th style="width: 50%;">If you search for a customer registration template using...</th> <th style="width: 50%;">Then...</th> </tr> </thead> <tbody> <tr> <td>The <b>Banking Template</b> option</td> <td>The valid values are: <ul style="list-style-type: none"> <li>Account</li> <li>Person</li> </ul> </td> </tr> <tr> <td>The <b>Healthcare Template</b> option</td> <td>The valid values are: <ul style="list-style-type: none"> <li>Account</li> <li>Person</li> <li>Policy</li> <li>Policy Plan</li> </ul> </td> </tr> </tbody> </table>	If you search for a customer registration template using...	Then...	The <b>Banking Template</b> option	The valid values are: <ul style="list-style-type: none"> <li>Account</li> <li>Person</li> </ul>	The <b>Healthcare Template</b> option	The valid values are: <ul style="list-style-type: none"> <li>Account</li> <li>Person</li> <li>Policy</li> <li>Policy Plan</li> </ul>	No
If you search for a customer registration template using...	Then...							
The <b>Banking Template</b> option	The valid values are: <ul style="list-style-type: none"> <li>Account</li> <li>Person</li> </ul>							
The <b>Healthcare Template</b> option	The valid values are: <ul style="list-style-type: none"> <li>Account</li> <li>Person</li> <li>Policy</li> <li>Policy Plan</li> </ul>							

- **Search Results** - On clicking the **Search** button, the search results appear based on the specified search criteria. The **Search Results** section contains the following columns:

Column Name	Column Description
Template	Displays the name of the customer registration template.
Description	Displays the description of the customer registration template.
Template Category	Displays the category of the customer registration template.

Column Name	Column Description	
Edit	<b>If...</b>	<b>Then</b>
	You click the <b>Edit</b> (  ) icon when the <b>Search By</b> option is <b>Banking Template</b>	The <b>Customer Registration Template for Banking</b> screen appears where you can edit the details of the customer registration banking template.
	You click the <b>Edit</b> (  ) icon when the <b>Search By</b> option is <b>Healthcare Template</b>	The <b>Customer Registration Template for Healthcare</b> screen appears where you can edit the details of the customer registration healthcare template.
<b>Note:</b> The <b>Edit</b> icon appears only when the customer registration template is not used while defining the customer registration type.		
Duplicate	<b>If...</b>	<b>Then</b>
	You click the <b>Duplicate</b> (  ) icon when the <b>Search By</b> option is <b>Banking Template</b>	The <b>Customer Registration Template for Banking</b> screen appears where you can create a copy of the customer registration banking template.
	You click the <b>Duplicate</b> (  ) icon when the <b>Search By</b> option is <b>Healthcare Template</b>	The <b>Customer Registration Template for Banking</b> screen appears where you can create a copy of the customer registration healthcare template.
Delete	On clicking the <b>Delete</b> (  ) icon, you can delete the customer registration template.	
	<b>Note:</b> The <b>Delete</b> icon appears only when the customer registration template is not used while defining the customer registration type. You can delete a customer registration template only when you have not created a customer registration using the customer registration template.	

**Note:** Pagination is used to display limited number of records in the **Search Results** section. You can use the navigation links, such as **Previous** and **Next** to navigate between pages.

On clicking the **Broadcast** () icon corresponding to a customer registration template, the **Customer Registration Template** zone appears with the details of the respective customer registration template.

You can filter the list using various search criteria (such as, **Template**, **Description**, and **Template Category**) available in the **Filter** area. By default, the **Filter** area is hidden. You can view the **Filter** area by clicking the **Filters** () icon in the upper right corner of this zone.

### Related Topics

For more information on...	See...
How to edit a customer registration template	<a href="#">Editing a Customer Registration Template</a> on page 81

For more information on...	See...
How to copy a customer registration template	<a href="#">Copying a Customer Registration Template</a> on page 84
How to delete a customer registration template	<a href="#">Deleting a Customer Registration Template</a> on page 87
How to view the details of a customer registration template	<a href="#">Viewing the Customer Registration Template Details</a> on page 77

## Customer Registration Template

The **Customer Registration Template** zone displays the details of the customer registration template. It contains the following sections:

- **Main** - Displays the basic information about the customer registration template. It contains the following fields:

Field Name	Field Description
Template Code	Displays the customer registration template code.
Template Category	Indicates the category of the customer registration template.
Description	Displays the description of the customer registration template.
Detailed Description	Displays additional information about the customer registration template.

- **Template Page** - The **Template Page** section lists the pages, sections and its respective fields defined for the customer registration template. It contains the following columns:

Column Name	Column Description												
Template Page	Indicates the template page.												
Template Section	Indicates the template section along with its respective fields.  <div style="border: 1px solid black; padding: 5px; margin: 5px 0;"> <p><b>Note:</b> The following table appears only when the template section contains fields that are defined for the customer registration template.</p> </div> <table border="1" style="width: 100%; border-collapse: collapse;"> <thead> <tr> <th>Field Name</th> <th>Field Description</th> </tr> </thead> <tbody> <tr> <td>Sequence</td> <td>Displays the sequence number of the field defined in the template section.</td> </tr> <tr> <td>Field</td> <td>Indicates the field that is defined for the customer registration template.</td> </tr> <tr> <td>Default Field Value</td> <td>Indicates the default value of the field.</td> </tr> <tr> <td>Required</td> <td>Indicates whether the field is required or not.</td> </tr> <tr> <td>Disable Field Value</td> <td>Indicates whether the value is disabled for the field or not.</td> </tr> </tbody> </table>	Field Name	Field Description	Sequence	Displays the sequence number of the field defined in the template section.	Field	Indicates the field that is defined for the customer registration template.	Default Field Value	Indicates the default value of the field.	Required	Indicates whether the field is required or not.	Disable Field Value	Indicates whether the value is disabled for the field or not.
Field Name	Field Description												
Sequence	Displays the sequence number of the field defined in the template section.												
Field	Indicates the field that is defined for the customer registration template.												
Default Field Value	Indicates the default value of the field.												
Required	Indicates whether the field is required or not.												
Disable Field Value	Indicates whether the value is disabled for the field or not.												

- **Record Actions** - The **Record Actions** section contains the following buttons:

Button Name	Button Description
Edit	Used to edit the details of the customer registration template.

Button Name	Button Description
Delete	Used to delete the customer registration template. <b>Note:</b> You can delete a customer registration template only when you have not created a customer registration using the customer registration template.
Duplicate	Used to create a new customer registration template using an existing customer registration template.

- **Record Information** - The **Record Information** section contains the following fields:

Field Name	Field Description
Business Object	Indicates the business object using which the customer registration template is created. In addition, a context menu appears corresponding to this field which helps in navigating to other screens in the application. <b>Note:</b> It has a link. On clicking the link, the <b>Business Object</b> screen appears where you can view the details of the respective business object.

By default, the **Customer Registration Template** zone does not appear in the **Customer Registration Template** screen. It appears only when you click the **Broadcast**  icon corresponding to the customer registration template in the **Customer Registration Template List** zone.

### **Related Topics**

For more information on...	See...
How to define a customer registration template	<a href="#">Defining a Customer Registration Template</a> on page 77
How to edit a customer registration template	<a href="#">Editing a Customer Registration Template</a> on page 81
How to copy a customer registration template	<a href="#">Copying a Customer Registration Template</a> on page 84
How to delete a customer registration template	<a href="#">Deleting a Customer Registration Template</a> on page 87
How to view the details of a customer registration template	<a href="#">Viewing the Customer Registration Template Details</a> on page 77

## **Searching for a Customer Registration Template**

### **Prerequisites**

To search for a customer registration template, you should have:

- Customer registration templates defined in the application

### **Procedure**

To search for a customer registration template:

1. Click the **Admin** link in the **Application** toolbar.  
A list appears.
2. From the **Admin** menu, select **C** and then click **Customer Registration Template**.  
A sub-menu appears.

- Click the **Search** option from the **Customer Registration Template** sub-menu.

The **Customer Registration Template** screen appears.

- Enter the search criteria in the **Customer Registration Template List** zone.

**Note:** ORMB search engine supports wildcard search, where you can substitute the percentage (%) symbol as a stand in for any word or letter in a search criteria. You can use the ‘%’ wildcard character in all input fields except the date and ID fields. The ‘%’ wildcard character is suffixed automatically at the end of the partial search criteria. Therefore, you may or may not specify the wildcard character at the end of the partial search criteria. However, you have to prefix the wildcard character manually wherever required.

- Click **Search**.

A list of customer registration template that meet the search criteria appears in the **Search Results** section.

#### Related Topics

For more information on...	See...
<b>Customer Registration Template</b> screen	<a href="#">Customer Registration Template</a> on page 71
<b>Search Customer Registration Template</b> zone	<a href="#">Search Customer Registration Template</a> on page 72

## Viewing the Customer Registration Template Details

### Procedure

To view the details of a customer registration template:

- Search for the customer registration template in the **Customer Registration Template List** screen.
- In the **Customer Registration Template List** zone, click the **Broadcast**  icon corresponding to the customer registration template whose details you want to view.

The **Customer Registration Template** zone appears.

- View the details of the customer registration template in the **Customer Registration Template** zone.

### Related Topics

For more information on...	See...
How to search for a customer registration template	<a href="#">Searching for a Customer Registration Template</a> on page 76
<b>Search Customer Registration Template</b> zone	<a href="#">Search Customer Registration Template</a> on page 72

## Defining a Customer Registration Template

### Prerequisites

To define a customer registration template, you should have:

- Customer registration template business objects defined in the application
- Template categories defined in the application

### Procedure

To define a customer registration template:

- Click the **Admin** link in the **Application** toolbar.

A list appears.

- From the **Admin** menu, select **C** and then click **Customer Registration Template**.

A sub-menu appears.

- Click the **Add** option from the **Customer Registration Template** sub-menu.

The **Select Business Object** screen appears. It contains the following field:

Field Name	Field Description	Mandatory (Yes or No)
Customer Registration Template Business Object	Used to indicate the business object using which you want to create the customer registration template. The valid values are: <ul style="list-style-type: none"> <li>Customer Registration Template - Banking</li> <li>Customer Registration Template - Healthcare</li> </ul>	Yes

**Tip:** Alternatively, you can access the **Select Business Object** screen by clicking the **Add** button in the **Page Title** area of the **Customer Registration Template** screen.

- Select the required customer registration business object from the respective field.
- Click **OK**.

The **Customer Registration Template - Banking** screen appears. It contains the following fields:

Field Name	Field Description	Mandatory (Yes or No)
Template Code	Used to specify the customer registration template.	Yes
Template Category	Used to indicate the template category using which you want to create the customer registration template. The valid values are: <ul style="list-style-type: none"> <li>Account</li> <li>Person</li> <li>Policy</li> <li>Policy Plan</li> </ul>	Yes
Business Object	Indicates the business object using which the customer registration template is defined in the system.	Not applicable
Description	Used to specify the description for the customer registration template.	Yes
Detailed Description	Used to specify additional information about the customer registration template.	No

Field Name	Field Description	Mandatory (Yes or No)
Template Page	<p>Used to indicate the template page using which you want to create the customer registration template.</p> <p><b>Note:</b> The following template pages are mandatory, if the <b>Template Category</b> is selected as <b>Account</b> in the <b>Main</b> section:</p> <ul style="list-style-type: none"> <li>• Main</li> <li>• Persons</li> </ul> <p>The following template pages are mandatory, if the <b>Template Category</b> is selected as <b>Person</b> in the <b>Main</b> section:</p> <ul style="list-style-type: none"> <li>• Main</li> </ul> <p>The following template pages are mandatory, if the <b>Template Category</b> is selected as <b>Policy</b> in the <b>Main</b> section:</p> <ul style="list-style-type: none"> <li>• Policy Main</li> </ul> <p>The following template pages are mandatory, if the <b>Template Category</b> is selected as <b>Policy Plan</b> in the <b>Main</b> section:</p> <ul style="list-style-type: none"> <li>• Plan</li> </ul>	Yes

Field Name	Field Description	Mandatory (Yes or No)
Template Section	<p>Used to indicate the template section using which you want to create the customer registration template.</p> <div style="border: 1px solid black; padding: 5px;"> <p><b>Note:</b> The following template sections are mandatory, if the <b>Template Category</b> is selected as <b>Account</b> and <b>Template page</b> is selected as <b>Main</b> in the <b>Main</b> section:</p> <ul style="list-style-type: none"> <li>• Account Identifiers</li> <li>• Account Information</li> </ul> <p>The following template sections are mandatory, if the <b>Template Category</b> is selected as <b>Account</b> and <b>Template page</b> is selected as <b>Persons</b> in the <b>Main</b> section:</p> <ul style="list-style-type: none"> <li>• Main</li> <li>• Bill Routing</li> </ul> <p>The following template sections are mandatory, if the <b>Template Category</b> is selected as <b>Person</b> and <b>Template page</b> is selected as <b>Main</b> in the <b>Main</b> section:</p> <ul style="list-style-type: none"> <li>• Person Identifiers</li> <li>• Person Main</li> <li>• Person Names</li> </ul> <p>The following template sections are mandatory, if the <b>Template Category</b> is selected as <b>Policy</b> and <b>Template page</b> is selected as <b>Policy Main</b> in the <b>Main</b> section:</p> <ul style="list-style-type: none"> <li>• Policy Main</li> </ul> <p>The following template sections are mandatory, if the <b>Template Category</b> is selected as <b>Policy Plan</b> and <b>Template page</b> is selected as <b>Plan</b> in the <b>Main</b> section:</p> <ul style="list-style-type: none"> <li>• Plan Main</li> </ul> </div>	Yes
Default Field	<p>Used to specify the default field using which you want to create the customer registration template.</p> <div style="border: 1px solid black; padding: 5px;"> <p><b>Note:</b> The list includes only those default fields which are associated to the specified template sections.</p> </div>	Yes

6. Enter the required details in the **Main** section.

7. Configure the template page, template section and set the default value for the relevant fields, if required.



## 8. Click **Save**.

The customer registration template is defined.

### Related Topics

For more information on...	See...
<b>Customer Registration Template</b> screen	<a href="#">Customer Registration Template</a> on page 71
How to set default fields for a customer registration template	<a href="#">Configuring Attributes to Copy Customer Registration Type</a> on page 101

## Editing a Customer Registration Template

### Prerequisites

To edit a customer registration template, you should have:

- Template categories defined in the application

### Procedure

To edit a customer registration template:

1. Click the **Admin** link in the **Application** toolbar.  
A list appears.
2. From the **Admin** menu, select **C** and then click **Customer Registration Template**.  
A sub-menu appears.
3. Click the **Search** option from the **Customer Registration Template** sub-menu.  
The **Customer Registration Template** screen appears.
4. Enter the search criteria in the **Customer Registration Template List** zone.
5. Click **Search**.

A list of customer registration template that meet the search criteria appears in the **Search Results** section.

6. In the **Search Result**, click the **Edit** (✎) icon in the **Edit** column corresponding to the customer registration template whose details you want to edit.

The **Customer Registration Template - Banking** screen appears. It contains the following fields:

Field Name	Field Description	Mandatory (Yes or No)
Template Code	Displays the customer registration template.	Yes
Template Category	Used to indicate the template category using which you want to create the customer registration template.	Yes
Business Object	Indicates the business object using which you want to create the customer registration template.	Not applicable
Description	Used to specify the description for the customer registration template.	Yes
Detailed Description	Used to specify additional information about the customer registration template.	No

Field Name	Field Description	Mandatory (Yes or No)
Template Page	<p>Used to indicate the template page using which you want to create the customer registration template.</p> <div style="border: 1px solid black; padding: 5px;"> <p><b>Note:</b> The following template pages are mandatory, if the <b>Template Category</b> is selected as <b>Account</b> in the <b>Main</b> section:</p> <ul style="list-style-type: none"> <li>• Main</li> <li>• Persons</li> </ul> <p>The following template pages are mandatory, if the <b>Template Category</b> is selected as <b>Person</b> in the <b>Main</b> section:</p> <ul style="list-style-type: none"> <li>• Main</li> </ul> <p>The following template pages are mandatory, if the <b>Template Category</b> is selected as <b>Policy</b> in the <b>Main</b> section:</p> <ul style="list-style-type: none"> <li>• Policy Main</li> </ul> <p>The following template pages are mandatory, if the <b>Template Category</b> is selected as <b>Policy Plan</b> in the <b>Main</b> section:</p> <ul style="list-style-type: none"> <li>• Plan</li> </ul> </div>	Yes

Field Name	Field Description	Mandatory (Yes or No)
Template Section	<p>Used to indicate the template section using which you want to create the customer registration template.</p> <div style="border: 1px solid black; padding: 5px;"> <p><b>Note:</b> The following template sections are mandatory, if the <b>Template Category</b> is selected as <b>Account</b> and <b>Template page</b> is selected as <b>Main</b> in the <b>Main</b> section:</p> <ul style="list-style-type: none"> <li>• Account Identifiers</li> <li>• Account Information</li> </ul> <p>The following template sections are mandatory, if the <b>Template Category</b> is selected as <b>Account</b> and <b>Template page</b> is selected as <b>Persons</b> in the <b>Main</b> section:</p> <ul style="list-style-type: none"> <li>• Main</li> <li>• Bill Routing</li> </ul> <p>The following template sections are mandatory, if the <b>Template Category</b> is selected as <b>Person</b> and <b>Template page</b> is selected as <b>Main</b> in the <b>Main</b> section:</p> <ul style="list-style-type: none"> <li>• Person Identifiers</li> <li>• Person Main</li> <li>• Person Names</li> </ul> <p>The following template sections are mandatory, if the <b>Template Category</b> is selected as <b>Policy</b> and <b>Template page</b> is selected as <b>Policy Main</b> in the <b>Main</b> section:</p> <ul style="list-style-type: none"> <li>• Policy Main</li> </ul> <p>The following template sections are mandatory, if the <b>Template Category</b> is selected as <b>Policy Plan</b> and <b>Template page</b> is selected as <b>Plan</b> in the <b>Main</b> section:</p> <ul style="list-style-type: none"> <li>• Plan Main</li> </ul> </div>	Yes
Default Field	<p>Used to specify the default field using which you want to create the customer registration template.</p> <div style="border: 1px solid black; padding: 5px;"> <p><b>Note:</b> The list includes only those default fields which are associated to the specified template sections.</p> </div>	Yes

**Tip:** Alternatively, you can edit the details of a customer registration template by clicking the **Edit** button in the **Customer Registration Template** zone.

7. Modify the details in the **Main** section, if required.
8. Configure the template page, template section and set the default value for the relevant fields, if required.
9. Click **Save**.

The changes made to the customer registration template are saved.

### Related Topics

For more information on...	See...
<b>Customer Registration Template</b> screen	<a href="#">Customer Registration Template</a> on page 71
<b>Search Customer Registration Template</b> zone	<a href="#">Search Customer Registration Template</a> on page 72
<b>Customer Registration Template</b> zone	<a href="#">Customer Registration Template</a> on page 75

## Copying a Customer Registration Template

Instead of creating a customer registration template from scratch, you can create a new customer registration template using an existing customer registration template. This is possible through copying a customer registration template. On copying a customer registration template, the details including the default fields are copied to the new customer registration template. You can then edit the details, if required.

### Prerequisites

To copy a customer registration template, you should have:

- Customer registration template (whose copy you want to create) defined in the application
- Template categories defined in the application

### Procedure

To copy a customer registration template:

1. Click the **Admin** link in the **Application** toolbar.

A list appears.

2. From the **Admin** menu, select **C** and then click **Customer Registration Template**.

A sub-menu appears.

3. Click the **Search** option from the **Customer Registration Template** sub-menu.

The **Customer Registration Template** screen appears.

4. In the **Customer Registration Template List** zone, click the **Duplicate**  icon in the **Duplicate** column corresponding to the customer registration template whose copy you want to create.

The **Customer Registration Template - Banking** screen appears. It contains the following fields:

Field Name	Field Description	Mandatory (Yes or No)
Template Code	Used to specify the customer registration template.	Yes
Template Category	Used to indicate the template category using which you want to create the customer registration template.	Yes
Business Object	Indicates the business object using which you want to create the customer registration template.	Not applicable

Field Name	Field Description	Mandatory (Yes or No)
Description	Used to specify the description for the customer registration template.	Yes
Detailed Description	Used to specify additional information about the customer registration template.	No
Template Page	<p>Used to indicate the template page using which you want to create the customer registration template.</p> <div style="border: 1px solid black; padding: 5px;"> <p><b>Note:</b> The following template pages are mandatory, if the <b>Template Category</b> is selected as <b>Account</b> in the <b>Main</b> section:</p> <ul style="list-style-type: none"> <li>• Main</li> <li>• Persons</li> </ul> <p>The following template pages are mandatory, if the <b>Template Category</b> is selected as <b>Person</b> in the <b>Main</b> section:</p> <ul style="list-style-type: none"> <li>• Main</li> </ul> <p>The following template pages are mandatory, if the <b>Template Category</b> is selected as <b>Policy</b> in the <b>Main</b> section:</p> <ul style="list-style-type: none"> <li>• Policy Main</li> </ul> <p>The following template pages are mandatory, if the <b>Template Category</b> is selected as <b>Policy Plan</b> in the <b>Main</b> section:</p> <ul style="list-style-type: none"> <li>• Plan</li> </ul> </div>	Yes

Field Name	Field Description	Mandatory (Yes or No)
Template Section	<p>Used to indicate the template section using which you want to create the customer registration template.</p> <div style="border: 1px solid black; padding: 5px;"> <p><b>Note:</b> The following sections are mandatory, if the <b>Template Category</b> is selected as <b>Account</b> and <b>Template page</b> is selected as <b>Main</b> in the <b>Main</b> section:</p> <ul style="list-style-type: none"> <li>• Account Identifiers</li> <li>• Account Information</li> </ul> <p>The following sections are mandatory, if the <b>Template Category</b> is selected as <b>Account</b> and <b>Template page</b> is selected as <b>Persons</b> in the <b>Main</b> section:</p> <ul style="list-style-type: none"> <li>• Main</li> <li>• Bill Routing</li> </ul> <p>The following sections are mandatory, if the <b>Template Category</b> is selected as <b>Person</b> and <b>Template page</b> is selected as <b>Main</b> in the <b>Main</b> section:</p> <ul style="list-style-type: none"> <li>• Person Identifiers</li> <li>• Person Main</li> <li>• Person Names</li> </ul> <p>The following sections are mandatory, if the <b>Template Category</b> is selected as <b>Policy</b> and <b>Template page</b> is selected as <b>Policy Main</b> in the <b>Main</b> section:</p> <ul style="list-style-type: none"> <li>• Policy Main</li> </ul> <p>The following sections are mandatory, if the <b>Template Category</b> is selected as <b>Policy Plan</b> and <b>Template page</b> is selected as <b>Plan</b> in the <b>Main</b> section:</p> <ul style="list-style-type: none"> <li>• Plan Main</li> </ul> </div>	Yes
Default Field	<p>Used to specify the default field using which you want to create the customer registration template.</p> <div style="border: 1px solid black; padding: 5px;"> <p><b>Note:</b> The list includes only those default fields which are associated to the specified template sections.</p> </div>	Yes

**Tip:** Alternatively, you can copy a customer registration template by clicking the **Duplicate** button in the **Customer Registration Template** zone.

5. Enter the required details in the **Main** section.

6. Configure the template page, template section and set the default value for the relevant fields, if required.
7. Click **Save**.

The new customer registration template is defined.

### Related Topics

For more information on...	See...
<b>Customer Registration Template</b> screen	<a href="#">Customer Registration Template</a> on page 71
<b>Search Customer Registration Template</b> zone	<a href="#">Search Customer Registration Template</a> on page 72
<b>Customer Registration Template</b> zone	<a href="#">Customer Registration Template</a> on page 75
How to set default fields for a customer registration type	<a href="#">Configuring Attributes to Copy Customer Registration Type</a> on page 101

## Deleting a Customer Registration Template

### Procedure

To delete a Customer Registration Template:

1. Click the **Admin** link in the **Application** toolbar.  
A list appears.
2. From the **Admin** menu, select **F** and then click **Customer Registration Template**.  
A sub-menu appears.
3. Click the **Search** option from the **Customer Registration Template** sub-menu.  
The **Customer Registration Template** screen appears.
4. In the **Customer Registration Template List** zone, click the **Delete** (🗑️) icon in the **Delete** column corresponding to the customer registration template that you want to delete.

A message appears confirming whether you want to delete the customer registration template.

**Note:** You can delete a customer registration template only when you have not created a customer registration using the customer registration template.

**Tip:** Alternatively, you can delete a customer registration template by clicking the **Delete** button in the **Customer Registration Template** zone.

5. Click **OK**.

The customer registration template is deleted.

### Related Topics

For more information on...	See...
<b>Customer Registration Template</b> screen	<a href="#">Customer Registration Template</a> on page 71
<b>Search Customer Registration Template</b> zone	<a href="#">Search Customer Registration Template</a> on page 72
<b>Customer Registration Template</b> zone	<a href="#">Customer Registration Template</a> on page 75

## Customer Registration Type

A customer registration type encapsulates the following information:

- Users with a particular access group can only create a customer registration object using the customer registration type
- Whether the customer registration type can be used to create a customer registration object from the user interface, through the inbound message, or through the **File Upload Interface** utility
- Whether the approval is required when you create, edit, or delete a customer registration object
- Whether the final level approval is required once the approver at the first level approves the customer registration object
- Whether a To Do should be created indicating that the users have to manually create the billing hierarchy and pricing for the parent customer.
- The business objects using which the person, account, policy plan, membership, and address should be created when a customer registration object is created using the customer registration type
- A customer registration template which indicates the pages and sections that should appear when you are creating a customer registration object using the customer registration type. You can specify one customer registration template for person and one or more customer registration templates for account, policy, and policy plan.
- Information, such as person names, person identifiers, person phones, person characteristics, person addresses, person hierarchy, accounts, account identifiers, account characteristics, account auto pay information, account persons, account bill routing information, policies, policy plans, policy characteristics, or policy plan characteristics, which should be copied when you create a copy of a customer registration object which is created using the customer registration type.

### Related Topics



For more information on...	See...
How to edit a customer registration type	<a href="#">Editing a Customer Registration Type</a> on page 104
How to copy a customer registration type	<a href="#">Copying a Customer Registration Type</a> on page 106
How to delete a customer registration type	<a href="#">Deleting a Customer Registration Type</a> on page 107
How to view the details of a customer registration type	<a href="#">Viewing the Customer Registration Type Details</a> on page 108

## Customer Registration Type List

The **Customer Registration Type List** zone lists the customer registration types that are already defined in the system. It contains the following columns:

Column Name	Column Description
Customer Registration Type	Displays the type code of the customer registration type.
Description	Displays the description of the customer registration type.
Edit	On clicking the <b>Edit</b> (  ) icon, the <b>Customer Registration Type - Banking</b> screen appears where you can edit the details of the customer registration type.



Column Name	Column Description
Duplicate	On clicking the <b>Duplicate</b> (  ) icon, the <b>Customer Registration Type - Banking</b> screen appears where you can define a new customer registration type using an existing customer registration type.
Delete	On clicking the <b>Delete</b> (  ) icon, you can delete the customer registration type.  <b>Note:</b> You can delete a customer registration type only when you have not created a customer registration using the customer registration type.

On clicking the **Broadcast** () icon corresponding to a customer registration type, the **Customer Registration Type** zone appears with the details of the respective customer registration type.

### Related Topics

For more information on...	See...
How to edit a customer registration type	<a href="#">Editing a Customer Registration Type</a> on page 104
How to copy a customer registration type	<a href="#">Copying a Customer Registration Type</a> on page 106
How to delete a customer registration type	<a href="#">Deleting a Customer Registration Type</a> on page 107
How to view the details of a customer registration type	<a href="#">Viewing the Customer Registration Type Details</a> on page 108

## Customer Registration Type

The **Customer Registration Type** zone displays the details of the customer registration type. It contains the following sections:

- **Main** - Displays the basic information about the customer registration type. It contains the following fields:

Field Name	Field Description
Customer Registration Type	Displays the Customer Registration Type.
Description	Displays the description of the customer registration type.
Customer Registration Business Object	Displays the business object using which you want to create the Customer Registration Type.
Detailed Description	Displays additional information about the customer registration type.
Status	Displays the status of the customer registration type. The valid values are: <ul style="list-style-type: none"> <li>• Active</li> <li>• Inactive</li> </ul> <b>Note:</b> You cannot change the status of a customer registration type to <b>Inactive</b> when the corresponding customer registration is in a status other than <b>Processed</b> or <b>Rejected</b> .

Field Name	Field Description
Access Group	<p>Displays the access group of the customer registration type.</p> <p>The <b>Search</b> (🔍) icon appears corresponding to the <b>Access Group</b> field. On clicking the <b>Search</b> icon, the <b>Access Group Search</b> window appears.</p> <p>On specifying the access group, the description of the access group appears corresponding to the <b>Access Group</b> field.</p>
Registration Source	Displays the registration source of the customer registration type.

- **Additional Data** - The **Additional Data** section lists the approval type, submitter type and its respective fields defined for the customer registration type. It contains the following fields:

Column Name	Column Description
Approval Required	Indicates whether approval is required while creating the customer registration using the customer registration type.
Approval To Do Type	<p>Indicates that the To Do entry of the specified To Do type must be created when you submit the customer registration for approval.</p> <div style="border: 1px solid black; padding: 5px;"> <p><b>Note:</b></p> <p>This field appears only when the <b>Approval Required</b> check box is selected.</p> <p>It has a link. On clicking the link, the <b>To Do Type</b> screen appears with the details of the respective To Do type.</p> <p>The <b>Search</b> (🔍) icon appears corresponding to this field. On clicking the <b>Search</b> icon, the <b>To Do Type Search</b> window appears.</p> </div>
Approval To Do Role	<p>Indicates that users with the specified To Do role can only approve or reject the customer registration submitted for approval.</p> <div style="border: 1px solid black; padding: 5px;"> <p><b>Note:</b></p> <p>This field appears only when the <b>Approval Required</b> check box is selected.</p> <p>It has a link. On clicking the link, the <b>To Do Role</b> screen appears with the details of the respective To Do role.</p> </div>
Submitter To Do Type	<p>Indicates the To Do type for the submitter when the funding request type is resubmitted by the approver.</p> <div style="border: 1px solid black; padding: 5px;"> <p><b>Note:</b></p> <p>The <b>Submitter To Do Type</b> field appears only when the <b>Approval Required</b> check box is selected.</p> <p>It has a link. On clicking the link, the <b>To Do Type</b> screen appears where you can view the details of the respective To Do type.</p> </div>

Column Name	Column Description
Submitter To Do Role	<p>Indicates the To Do role for the submitter when the funding request type is resubmitted by the approver.</p> <p><b>Note:</b> The <b>Submitter To Do Role</b> field appears only when the <b>Approval Required</b> check box is selected. It has a link. On clicking the link, the <b>To Do Role</b> screen appears where you can view the details of the respective To Do role.</p>
Person Business Object	<p>Indicates the business object using which the customer registration type for a person is created. In addition, a context menu appears corresponding to this field which helps in navigating to other screens in the application.</p> <p><b>Note:</b> It has a link. On clicking the link, the <b>Business Object</b> screen appears where you can view the details of the respective business object.</p>
Account Business Object	<p>Indicates the business object using which the customer registration type for an account is created. In addition, a context menu appears corresponding to this field which helps in navigating to other screens in the application.</p> <p><b>Note:</b> It has a link. On clicking the link, the <b>Business Object</b> screen appears where you can view the details of the respective business object.</p>
Address Business Object	<p>Indicates the business object using which the customer registration type for an address is created. In addition, a context menu appears corresponding to this field which helps in navigating to other screens in the application.</p> <p><b>Note:</b> It has a link. On clicking the link, the <b>Business Object</b> screen appears where you can view the details of the respective business object.</p>

- **Characteristics** - The **Record Information** section contains the following columns:

Field Name	Field Description
Characteristic Type	Indicates the characteristic type.
Characteristic Value	Displays the value of the characteristic type.

- **Customer Registration Templates** - The **Customer Registration Templates** section contains the following columns:

Field Name	Field Description
Sequence	Displays the sequence of the <b>Customer Registration Type</b> .
Template Category	Displays the template category of the <b>Customer Registration Type</b> .
Template	Indicates the template of the <b>Customer Registration Type</b> .

- **Record Actions** - The **Record Actions** section contains the following buttons:

Button Name	Button Description
Edit	Used to edit the details of the customer registration type.

Button Name	Button Description
Delete	Used to delete the customer registration type.  <b>Note:</b> You can delete a customer registration type only when you have not created a customer registration using the customer registration type.
Duplicate	Used to create a new customer registration type using an existing customer registration type.

- **Record Information** - The **Record Information** section contains the following fields:

Field Name	Field Description
Business Object	Indicates the business object using which the customer registration type is created. In addition, a context menu appears corresponding to this field which helps in navigating to other screens in the application.  <b>Note:</b> It has a link. On clicking the link, the <b>Business Object</b> screen appears where you can view the details of the respective business object.

- **Copy Customer Registration Details** - The **Copy Customer Registration Details** section lists allows to copy certain fields and its respective details defined for the customer registration type. It contains the following fields:

Column Name	Column Description
Person Names	Indicates whether the field <b>Person Names</b> and its respective details need to be copied while creating the customer registration type.
Accounts	Indicates whether the field <b>Accounts</b> and its respective details need to be copied while creating the customer registration type.
Person Identifiers	Indicates whether the field <b>Person Identifiers</b> and its respective details need to be copied while creating the customer registration type.
Account Identifiers	Indicates whether the field <b>Account Identifiers</b> and its respective details need to be copied while creating the customer registration type.
Person Phones	Indicates whether the field <b>Person Phones</b> and its respective details need to be copied while creating the customer registration type.
Account Characteristics	Indicates whether the field <b>Account Characteristics</b> and its respective details need to be copied while creating the customer registration type.
Person Characteristics	Indicates whether the field <b>Person Characteristics</b> and its respective details need to be copied while creating the customer registration type.
Account Auto Pay Information	Indicates whether the field <b>Account Auto Pay Information</b> and its respective details need to be copied while creating the customer registration type.
Person Addresses	Indicates whether the field <b>Person Addresses</b> and its respective details need to be copied while creating the customer registration type.
Account Persons	Indicates whether the field <b>Account Persons</b> and its respective details need to be copied while creating the customer registration type.
Person Hierarchy	Indicates whether the field <b>Person Hierarchy</b> and its respective details need to be copied while creating the customer registration type.

Column Name	Column Description
Account Override Address	Indicates whether the field <b>Account Override Address</b> and its respective details need to be copied while creating the customer registration type.
Bill Routing Information	Indicates whether the field <b>Bill Routing Information</b> and its respective details need to be copied while creating the customer registration type.
Credit Rating History	Indicates whether the field <b>Credit Rating History</b> and its respective details need to be copied while creating the customer registration type.

By default, the **Customer Registration Type** zone does not appear in the **Customer Registration Type** screen. It appears only when you click the **Broadcast**  icon corresponding to the customer registration template in the **Customer Registration Type List** zone.

### Related Topics

For more information on...	See...
How to define a customer registration type	<a href="#">Defining a Customer Registration Type</a> on page 94
How to edit a customer registration type	<a href="#">Editing a Customer Registration Type</a> on page 104
How to copy a customer registration type	<a href="#">Copying a Customer Registration Type</a> on page 106
How to delete a customer registration type	<a href="#">Deleting a Customer Registration Type</a> on page 107
How to view the details of a customer registration type	<a href="#">Viewing the Customer Registration Type Details</a> on page 108

## Searching for a Customer Registration Type

### Prerequisites

To search for a customer registration type, you should have:

- Customer registration types defined in the application

### Procedure

To search for a customer registration type:

1. Click the **Admin** link in the **Application** toolbar.  
A list appears.
2. From the **Admin** menu, select **C** and then click **Customer Registration Type**.  
A sub-menu appears.
3. Click the **Search** option from the **Customer Registration Type** sub-menu.  
The **Customer Registration Type** screen appears.
4. Enter the search criteria in the **Customer Registration Type List** zone.

**Note:** ORMB search engine supports wildcard search, where you can substitute the percentage (%) symbol as a stand in for any word or letter in a search criteria. You can use the ‘%’ wildcard character in all input fields except the date and ID fields. The ‘%’ wildcard character is suffixed automatically at the end of the partial search criteria. Therefore, you may or may not specify the wildcard character at the end of the partial search criteria. However, you have to prefix the wildcard character manually wherever required.

5. Click **Search**.

A list of customer registration types that meet the search criteria appears in the **Search Results** section.

**Related Topics**

For more information on...	See...
<b>Customer Registration Type</b> screen	<a href="#">Customer Registration Type</a> on page 88
<b>Customer Registration Type</b> zone	<a href="#">Customer Registration Type</a> on page 89

**Defining a Customer Registration Type****Prerequisites**

To define a customer registration type, you should have:

- Customer registration type business objects defined in the application
- Customer registration business objects defined in the application
- Person business objects defined in the application
- Account business objects defined in the application
- Address business objects defined in the application
- Access groups defined in the application
- Registration sources defined in the application
- Characteristic types defined in the application
- Template categories defined in the application

**Procedure**

To define a customer registration type:

1. Click the **Admin** link in the **Application** toolbar.  
A list appears.
2. From the **Admin** menu, select **C** and then click **Customer Registration Type**.  
A sub-menu appears.
3. Click the **Add** option from the **Customer Registration Type** sub-menu.

The **Select Business Object** screen appears. It contains the following field:

Field Name	Field Description	Mandatory (Yes or No)
Customer Registration Type Business Object	Used to indicate the business object using which you want to create the customer registration type. The valid values are: <ul style="list-style-type: none"> <li>• Customer Registration Type (C1-CustomerRegistration)</li> <li>• Customer Registration Type - Banking (C1-CustomerRegistrationBanking)</li> <li>• Customer Registration Type - Healthcare (C1-CustomerRegistrationHC)</li> </ul>	Yes

**Tip:** Alternatively, you can access the **Select Business Object** screen by clicking the **Add** button in the **Page Title** area of the **Customer Registration Type** screen.

4. Select the **Customer Registration Type - Banking** business object from the respective field.
5. Click **OK**.

The **Customer Registration Type** screen appears. It contains the following sections:

- **Main** - Used to specify basic details about the customer registration type.
- **Additional Data** - Used to provide the additional information about the customer registration type.
- **Characteristics** - Used to lists characteristics defined for the customer registration type.
- **Customer Registration Type Template** - Used to lists template categories for the customer registration type.
- **Copy Customer Registration**- Used to indicate template pages, template sections and their respective fields to be copied for the customer registration.
- **Main** - The **Main** section contains the following fields:

Field Name	Field Description	Mandatory (Yes or No)
Customer Registration Type	Used to specify the customer registration type.	Yes
Business Object	Indicates the business object using which you want to create a customer registration type.	Not applicable
Description	Used to specify the description for the customer registration type.	Yes
Customer Registration Business Object	Used to indicate the customer registration business object using which you want to create a customer registration type.	Yes
Detailed Description	Used to specify additional information about the customer registration type.	No
Status	Used to indicate the status of the customer registration type.	Yes
Access Group	Used to specify the access group of the customer registration type.  The <b>Search</b>  icon appears corresponding to the <b>Access Group</b> field. On clicking the <b>Search</b> icon, the <b>Access Group Search</b> window appears.	Yes
Registration Source	Used to indicate the registration source of the customer registration type.	Yes

- **Additional Data**- The **Additional Data** section is used to provide the additional information about the customer registration type. It contains the following fields:

Field Name	Field Description	Mandatory (Yes or No)
Approval Required	Used to indicate whether the approval is required before creating the customer registration type.	No
Person Business Object	Used to indicate the business object for a person.	Yes

Field Name	Field Description	Mandatory (Yes or No)
Account Business Object	Used to indicate the business object for an account.	Yes
Address Business Object	Used to indicate the business object for an address.	Yes

6. Enter the required details in the **Main** section.
7. Enter the required details in the **Additional Data** section.
8. Configure the template page, template section and set the default value for the relevant fields, if required.
9. Select the **Person** fields to copy customer registration, if required.
10. Select the **Accounts** fields to copy customer registration, if required.
11. Click **Save**.

The customer registration type is defined.

### **Related Topics**

For more information on...	See...
<b>Customer Registration Type</b> screen	<a href="#">Customer Registration (Used for Viewing)</a> on page 154
How to configure default fields for a customer registration type	<a href="#">Configuring Attributes to Copy Customer Registration Type</a> on page 101

## **Defining an Additional Data for a Customer Registration Type**

### **Prerequisites**

To define an additional data for a customer registration type, you should have:

- Characteristic types defined in the application (where the characteristic entity is set to **Customer Registration Type**)

### **Procedure**

To define an additional data for a customer registration type:

1. Ensure that the **Additional Data** section is expanded when you are defining, editing, or copying a customer registration type.

The **Additional Data** section contains the following fields:

Field Name	Field Description	Mandatory (Yes or No)
Approval Required	Used to indicate whether approval is required while creating the customer registration using the customer registration type.  <b>Note:</b> The list includes only those characteristic types where the characteristic entity is set to <b>Customer Registration Type</b> .	Yes (Conditional)  <b>Note:</b> This field is required when the <b>Approval Required</b> checkbox is selected.



Field Name	Field Description	Mandatory (Yes or No)
Approval To Do Type	<p>Used to indicate that the To Do entry of the specified To Do type must be created when you submit the customer registration for approval.</p> <p><b>Note:</b> This field appears only when the <b>Approval Required</b> check box is selected.</p> <p>It has a link. On clicking the link, the <b>To Do Type</b> screen appears with the details of the respective To Do type.</p> <p>The <b>Search</b>  icon appears corresponding to this field. On clicking the <b>Search</b> icon, the <b>To Do Type Search</b> window appears.</p>	<p>Yes (Conditional)</p> <p><b>Note:</b> This field is required when the <b>Approval Required</b> checkbox is selected.</p>
Approval To Do Role	<p>Used to indicate that users with the specified To Do role can only approve or reject the customer registration submitted for approval.</p> <p><b>Note:</b> This field appears only when the <b>Approval Required</b> check box is selected.</p> <p>It has a link. On clicking the link, the <b>To Do Role</b> screen appears with the details of the respective To Do role.</p>	<p>Yes (Conditional)</p> <p><b>Note:</b> This field is required when the <b>Approval Required</b> checkbox is selected.</p>
Submitter To Do Type	<p>Used to indicates the To Do type for the submitter when the funding request type is resubmitted by the approver.</p> <p><b>Note:</b> The <b>Submitter To Do Type</b> field appears only when the <b>Approval Required</b> check box is selected.</p> <p>It has a link. On clicking the link, the <b>To Do Type</b> screen appears where you can view the details of the respective To Do type.</p>	<p>Yes (Conditional)</p> <p><b>Note:</b> This field is required when the <b>Approval Required</b> checkbox is selected.</p>

Field Name	Field Description	Mandatory (Yes or No)
Submitter To Do Role	<p>Indicates the To Do role for the submitter when the funding request type is resubmitted by the approver.</p> <p><b>Note:</b> The <b>Submitter To Do Role</b> field appears only when the <b>Approval Required</b> check box is selected.</p> <p>It has a link. On clicking the link, the <b>To Do Role</b> screen appears where you can view the details of the respective To Do role.</p>	<p>Yes (Conditional)</p> <p><b>Note:</b> This field is required when the <b>Approval Required</b> checkbox is selected.</p>
Person Business Object	<p>Indicates the business object using which the customer registration type for a person is created. In addition, a context menu appears corresponding to this field which helps in navigating to other screens in the application.</p> <p><b>Note:</b> It has a link. On clicking the link, the <b>Business Object</b> screen appears where you can view the details of the respective business object.</p>	<p>Yes</p>
Account Business Object	<p>Indicates the business object using which the customer registration type for an account is created. In addition, a context menu appears corresponding to this field which helps in navigating to other screens in the application.</p> <p><b>Note:</b> It has a link. On clicking the link, the <b>Business Object</b> screen appears where you can view the details of the respective business object.</p>	<p>Yes</p>

Field Name	Field Description	Mandatory (Yes or No)
Address Business Object	Used to indicate the business object using which the customer registration type for an address is created. In addition, a context menu appears corresponding to this field which helps in navigating to other screens in the application.  <b>Note:</b> It has a link. On clicking the link, the <b>Business Object</b> screen appears where you can view the details of the respective business object.	Yes

- Enter the required details in the **Additional Data** section.

### Related Topics

For more information on...	See...
How to define a customer registration type	<a href="#">Defining a Customer Registration</a> on page 119
How to edit a customer registration type	<a href="#">Editing the Customer Registration Details</a> on page 166
How to copy a customer registration type	<a href="#">Copying a Customer Registration</a> on page 147

## Defining a Characteristic for a Customer Registration Type

### Prerequisites

To define a characteristic for a customer registration type, you should have:

- Characteristic types defined in the application (where the characteristic entity is set to **Customer Registration Type**)

### Procedure

To define a characteristic for a customer registration type:

- Ensure that the **Characteristics** section is expanded when you are defining, editing, or copying a customer registration type.

The **Characteristics** section contains the following fields:

Field Name	Field Description	Mandatory (Yes or No)
Characteristic Type	Used to indicate the characteristic type.  <b>Note:</b> The list includes only those characteristic types where the characteristic entity is set to <b>Customer Registration Type</b> .	Yes (Conditional)  <b>Note:</b> This field is required when you are defining a characteristic for the customer registration type.

Field Name	Field Description	Mandatory (Yes or No)
Characteristic Value	Used to specify the value for the characteristic type.	Yes (Conditional) <b>Note:</b> This field is required when you are defining a characteristic for the customer registration type.

- Enter the required details in the **Characteristics** section.
- If you want to define more than one characteristic for the customer registration type, click the **Add** (+) icon and then repeat step 2.

**Note:** However, if you want to remove a characteristic from the customer registration type, click the **Delete** (🗑️) icon corresponding to the characteristic.

### Related Topics

For more information on...	See...
How to define a customer registration type	<a href="#">Defining a Customer Registration</a> on page 119
How to edit a customer registration type	<a href="#">Editing the Customer Registration Details</a> on page 166
How to copy a customer registration type	<a href="#">Copying a Customer Registration</a> on page 147

## Adding a Template in a Customer Registration Type

### Prerequisites

To add a template in a customer registration type, you should have:

- Template categories defined in the application

### Procedure

To add a template in a customer registration type:

- Ensure that the **Customer Registration Type Templates** section is expanded when you are defining, editing, or copying a customer registration type.

The **Customer Registration Type Templates** section contains the following fields:

Field Name	Field Description	Mandatory (Yes or No)
Sequence	Used to specify the sequence for the customer registration type.	Yes (Conditional) <b>Note:</b> This field is required when you are adding a template to the customer registration type.
Template Category	Used to indicate the template category for the customer registration type.	Yes (Conditional) <b>Note:</b> This field is required when you are adding a template to the customer registration type.

Field Name	Field Description	Mandatory (Yes or No)
Template	Used to specify the template for the customer registration type.  <b>Note:</b> The Search  icon appears corresponding to the <b>Template Code</b> field. On clicking the <b>Search</b> icon, you can search for a template.	Yes (Conditional)  <b>Note:</b> This field is required when you are adding a template to the customer registration type.

- Enter the required details in the **Customer Registration Type Templates** section.
- If you want to define more than one template for the customer registration type, click the **Add**  icon and then repeat step 2.

**Note:** However, if you want to remove a template from the customer registration type, click the **Delete**  icon corresponding to the customer registration type template.

### Related Topics

For more information on...	See...
How to define a customer registration type	<a href="#">Defining a Customer Registration</a> on page 119
How to edit a customer registration type	<a href="#">Editing the Customer Registration Details</a> on page 166
How to copy a customer registration type	<a href="#">Copying a Customer Registration</a> on page 147

## Configuring Attributes to Copy Customer Registration Type

### Prerequisites

To configure an attribute for a customer registration type, you should have:

- Person** attributes defined in the application
- Account** attributes defined in the application

### Procedure

To configure an attribute for a customer registration type:

- Ensure that the **Copy Customer Registration Details** section is expanded when you are defining, editing, or copying a customer registration type.

The **Copy Customer Registration Details** section contains the following fields in a grid:

Field Name	Field Description	Mandatory (Yes or No)
Person Names	Used to indicate the person names in the customer registration.	No
Accounts	Used to indicate the account in the customer registration.	No
Person Identifiers	Used to indicate the person identifiers in the customer registration.	No

Field Name	Field Description	Mandatory (Yes or No)
Account Identifiers	Used to indicate the account identifiers in the customer registration.  <b>Note:</b> This field is enabled only when the <b>Accounts</b> field is selected in the <b>Copy Customer Registration Details</b> section.	No
Person Phones	Used to indicate the person phones in the customer registration.	No
Account Characteristics	Used to indicate the characteristics defined for the account in the customer registration.  <b>Note:</b> This field is enabled only when the <b>Accounts</b> field is selected in the <b>Copy Customer Registration Details</b> section.	No
Person Characteristics	Used to indicate the characteristics defined for the person in the customer registration.	No
Account Autopays Information	Used to indicate the account autopays information in the customer registration.  <b>Note:</b> This field is enabled only when the <b>Accounts</b> field is selected in the <b>Copy Customer Registration Details</b> section.	No
Person Addresses	Used to indicate the person addresses in the customer registration.	No
Account Persons	Used to indicate the account persons in the customer registration.  <b>Note:</b> This field is enabled only when the <b>Accounts</b> field is selected in the <b>Copy Customer Registration Details</b> section.	No
Person Hierarchy	Used to indicate the hierarchy of the person in the customer registration.	No
Account Override Address	Used to specify the account override address information in the customer registration.  <b>Note:</b> This field is enabled only when the <b>Accounts</b> field is selected in the <b>Copy Customer Registration Details</b> section.	No
Bill Routing Information	Used to indicate the bill routings in the customer registration.  <b>Note:</b> This field is enabled only when the <b>Accounts</b> field is selected in the <b>Copy Customer Registration Details</b> section.	No

Field Name	Field Description	Mandatory (Yes or No)
Credit Rating History	Used to indicate the credit rating history in the customer registration.  <b>Note:</b> This field is enabled only when the <b>Accounts</b> field is selected in the <b>Copy Customer Registration Details</b> section.	No
Policies	Used to indicate the policies in the customer registration.  <b>Note:</b> This field appears only when the <b>Customer Registration Type</b> is selected as <b>Healthcare</b>	No
Policy Plans	Used to indicate the policy plans in the customer registration.  <b>Note:</b> This field appears only when the <b>Customer Registration Type</b> is selected as <b>Healthcare</b> This field is enabled only when the <b>Policies</b> field is selected in the <b>Copy Customer Registration Details</b> section.	No
Policy Characteristics	Used to indicate the policy characteristics in the customer registration.  <b>Note:</b> This field appears only when the <b>Customer Registration Type</b> is selected as <b>Healthcare</b> This field is enabled only when the <b>Policies</b> field is selected in the <b>Copy Customer Registration Details</b> section.	No
Plan Characteristics	Used to indicate the plan characteristics in the customer registration.  <b>Note:</b> This field appears only when the <b>Customer Registration Type</b> is selected as <b>Healthcare</b> This field is enabled only when the <b>Policies</b> field is selected in the <b>Copy Customer Registration Details</b> section.	No

2. Select the required attributes in the **Copy Customer Registration Details** section.

### Related Topics

For more information on...	See...
How to define a customer registration type	<a href="#">Defining a Customer Registration Type</a> on page 94
How to edit a customer registration type	<a href="#">Editing a Customer Registration Type</a> on page 104
How to copy a customer registration type	<a href="#">Copying a Customer Registration Type</a> on page 106

## Editing a Customer Registration Type

### Prerequisites

To edit a customer registration type, you should have:

- Access groups defined in the application
- Registration sources defined in the application
- Customer registration business objects defined in the application
- Person business objects defined in the application
- Account business objects defined in the application
- Plan business objects defined in the application
- Membership business objects defined in the application
- Address business objects defined in the application
- Characteristic types defined in the application
- Template categories defined in the application

### Procedure

To edit a customer registration type:

1. Click the **Admin** link in the **Application** toolbar.  
A list appears.
2. From the **Admin** menu, select **C** and then click **Customer Registration Type**.  
A sub-menu appears.
3. Click the **Search** option from the **Customer Registration Type** sub-menu.  
The **Customer Registration Type** screen appears.
4. Click the **Filter** () icon in the title bar of the **Customer Registration Type List** zone.  
It contains the following fields:

Field Name	Field Description	Mandatory (Yes or No)
Customer Registration Type	Used to specify the customer registration type.	No
Description	Used to specify the description.	No

5. Enter the search criteria in the **Customer Registration Type List** zone.
6. Click **Search**.  
A list of customer registration template that meet the search criteria appears in the **Search Results** section.



7. In the **Search Result**, click the **Edit** (✎) icon in the **Edit** column corresponding to the customer registration template whose details you want to edit.

The **Customer Registration Type** screen appears. It contains the following fields:

Field Name	Field Description	Mandatory (Yes or No)
Customer Registration Type	Displays the customer registration type.	Yes
Business Object	Indicates the business object using which you want to create the customer registration type.	Not applicable
Description	Used to specify the description for the customer registration type.	Yes
Detailed Description	Used to specify additional information about the customer registration type.	No
Status	Used to indicate the status of the customer registration type. The valid values are: <ul style="list-style-type: none"> <li>Active</li> <li>Inactive</li> </ul>	Yes
Access Group	Used to specify an access group of the customer registration type. <div style="border: 1px solid black; padding: 5px; margin-top: 10px;"> <p><b>Note:</b></p> <p>The <b>Search</b> (🔍) icon appears corresponding to the <b>Access Group</b> field. On clicking the <b>Search</b> icon, the <b>Access Group Search</b> window appears.</p> </div>	Yes
Registration Source	Used to indicate the registration source of the customer registration type	Yes

**Tip:** Alternatively, you can edit the details of a customer registration template by clicking the **Edit** button in the **Customer Registration Type** zone.

8. Modify the details in the **Main** section, if required.
9. Configure the template page, template section and set the default value for the relevant fields, if required.
10. Click **Save**.

The changes made to the customer registration type are saved.

#### Related Topics

For more information on...	See...
<b>Customer Registration Type</b> screen	<a href="#">Customer Registration (Used for Viewing)</a> on page 154
<b>Customer Registration Type List</b> zone	<a href="#">Customer Registration Type List</a> on page 88
<b>Customer Registration Type</b> zone	<a href="#">Customer Registration Type</a> on page 89

## Copying a Customer Registration Type

Instead of creating a customer registration type from scratch, you can create a new customer registration type using an existing customer registration type. This is possible through copying a customer registration type. On copying a customer registration type, the details including the default fields are copied to the new customer registration type. You can then edit the details, if required.

### Prerequisites

To copy a customer registration type, you should have:

- Customer registration type (whose copy you want to create) defined in the application
- Template categories defined in the application

### Procedure

To copy a customer registration type:

1. Click the **Admin** link in the **Application** toolbar.

A list appears.

2. From the **Admin** menu, select **C** and then click **Customer Registration Type**.

A sub-menu appears.

3. Click the **Search** option from the **Customer Registration Type** sub-menu.

The **Customer Registration Type** screen appears.

4. In the **Customer Registration Type List** zone, click the **Duplicate** () icon in the **Duplicate** column corresponding to the customer registration type whose copy you want to create.

The **Customer Registration Type** screen appears. It contains the following fields:

Field Name	Field Description	Mandatory (Yes or No)
Customer Registration Type	Used to specify the customer registration type.	Yes
Business Object	Indicates the business object using which you want to create a customer registration type.	Not applicable
Description	Used to specify the description for the customer registration type.	Yes
Customer Registration Business Object	Used to indicate the customer registration business object using which you want to create a customer registration type.	Yes
Detailed Description	Used to specify additional information about the customer registration type.	No
Status	Used to indicate the status of the customer registration type.	Yes

Field Name	Field Description	Mandatory (Yes or No)
Access Group	Used to specify the access group of the customer registration type.  The <b>Search</b>  icon appears corresponding to the <b>Access Group</b> field. On clicking the <b>Search</b> icon, the <b>Access Group Search</b> window appears.  On specifying the access group, the description of the access group appears corresponding to the <b>Access Group</b> field.	Yes
Registration Source	Used to indicate the registration source of the customer registration type.	Yes

**Tip:** Alternatively, you can copy a customer registration type by clicking the **Duplicate** button in the **Customer Registration Type** zone.

5. Enter the required details in the **Main** section.
6. Enter the required details in the **Additional Data** section.
7. Define characteristics for the customer registration type, if required.
8. Configure the template page, template section and set the default value for the relevant fields, if required.
9. Select the required fields in the **Copy Customer Registration Details** section.
10. Click **Save**.

The new customer registration type is defined.

#### Related Topics

For more information on...	See...
<b>Customer Registration Type</b> screen	<a href="#">Customer Registration Type</a> on page 88
<b>Customer Registration Type List</b> zone	<a href="#">Customer Registration Type List</a> on page 88
<b>Customer Registration Type</b> zone	<a href="#">Customer Registration Type</a> on page 89
How to configure default fields for a customer registration type	<a href="#">Configuring Attributes to Copy Customer Registration Type</a> on page 101

## Deleting a Customer Registration Type

### Procedure

To delete a Customer Registration Type:

1. Click the **Admin** link in the **Application** toolbar.  
A list appears.
2. From the **Admin** menu, select **F** and then click **Customer Registration Type**.  
A sub-menu appears.
3. Click the **Search** option from the **Customer Registration Type** sub-menu.  
The **Customer Registration Type** screen appears.

- In the **Customer Registration Type List** zone, click the **Delete** () icon in the **Delete** column corresponding to the customer registration type that you want to delete.

A message appears confirming whether you want to delete the customer registration type.

**Note:** You can delete a customer registration type only when you have not created a customer registration using the customer registration type.

**Tip:** Alternatively, you can delete a customer registration type by clicking the **Delete** button in the **Customer Registration Type** zone.

- Click **OK**.

The customer registration type is deleted.

#### Related Topics

For more information on...	See...
<b>Customer Registration Type</b> screen	<a href="#">Customer Registration Type</a> on page 88
<b>Customer Registration Type</b> zone	<a href="#">Customer Registration Type</a> on page 89

## Viewing the Customer Registration Type Details

### Procedure

To view the details of a customer registration type:

- Search for the customer registration type in the **Customer Registration Type List** screen.
- In the **Customer Registration Type List** zone, click the **Broadcast** () icon corresponding to the customer registration type whose details you want to view.

The **Customer Registration Type** zone appears.

- View the details of the customer registration type in the **Customer Registration Type** zone.

### Related Topics

For more information on...	See...
How to search for a customer registration type	<a href="#">Searching a Customer Registration</a> on page 117
<b>Customer Registration Type List</b> screen	<a href="#">Customer Registration Type List</a> on page 88
<b>Customer Registration Type</b> zone	<a href="#">Customer Registration Type</a> on page 89

## Customer Registration (Used for Searching)

The **Customer Registration** screen allows you to search for a customer registration object using various search criteria. It contains the following zone:

- Search Customer Registration

For more information on...	See...
How to define a customer registration	<a href="#">Defining a Customer Registration</a> on page 119
How to edit a customer registration	<a href="#">Editing the Customer Registration Details</a> on page 166

For more information on...	See...
How to copy a customer registration	<a href="#">Copying a Customer Registration</a> on page 147
How to delete a customer registration	<a href="#">Deleting a Customer Registration</a>
How to view the details of a customer registration	<a href="#">Viewing the Customer Registration Details</a> on page 118

## Search Customer Registration

The **Search Customer Registration** zone allows you to search for a customer registration using various search criteria. It contains the following two sections:

- **Search Criteria** - The **Search Criteria** section contains the following fields:

Field Name	Field Description	Mandatory (Yes or No)
Search By	Used to indicate whether you want to search for a customer registration using the customer registration details. The valid values are: <ul style="list-style-type: none"> <li>• Registration Details</li> <li>• Person Details</li> <li>• Inbound Message Details</li> <li>• File Upload Details</li> </ul> <div style="border: 1px solid black; padding: 5px; margin-top: 10px;"> <b>Note:</b> By default, the <b>Registration Details</b> option is selected. </div>	Yes
Customer Registration ID	Used to specify the customer registration ID using which you want to search for a customer registration.	No
Created From	Used to search customer registrations which are created from a particular date onwards. <div style="border: 1px solid black; padding: 5px; margin-top: 10px;"> <b>Note:</b> This field appears only when the following options are selected from the <b>Search By</b> list: <ul style="list-style-type: none"> <li>• <b>Registration Details</b></li> <li>• <b>Inbound Message Details</b></li> </ul> </div>	No
User ID	Used to specify user id to search customer registration. <div style="border: 1px solid black; padding: 5px; margin-top: 10px;"> <b>Note:</b> This field appears only when the following options are selected from the <b>Search By</b> list: <ul style="list-style-type: none"> <li>• <b>Registration Details</b></li> <li>• <b>Inbound Message Details</b></li> </ul> </div>	No

Field Name	Field Description	Mandatory (Yes or No)
Created To	<p>Used to search customer registrations which are created till a particular date.</p> <div data-bbox="586 289 1122 485" style="border: 1px solid black; padding: 5px;"> <p><b>Note:</b> This field appears only when the following options are selected from the <b>Search By</b> list:</p> <ul style="list-style-type: none"> <li>• <b>Registration Details</b></li> <li>• <b>Inbound Message Details</b></li> </ul> </div>	No
Status	<p>Used to search customer registration with a particular status. The valid values are:</p> <ul style="list-style-type: none"> <li>• Approval In Progress</li> <li>• Bill Group Approved</li> <li>• Complete</li> <li>• Draft</li> <li>• Draft for Update</li> <li>• Parent Customer Approved</li> <li>• Pending Final Approval</li> <li>• Pending Pricing Correction</li> <li>• Rejected</li> </ul> <div data-bbox="586 1024 1122 1136" style="border: 1px solid black; padding: 5px;"> <p><b>Note:</b> These values appears only when the <b>Registration Details</b> option is selected from the <b>Search By</b> list.</p> <ul style="list-style-type: none"> <li>• Pending</li> <li>• Processed</li> <li>• Rejected</li> <li>• Void</li> <li>• Voided</li> </ul> </div> <div data-bbox="586 1392 1122 1503" style="border: 1px solid black; padding: 5px;"> <p><b>Note:</b> These values appears only when the <b>Inbound Message Details</b> option is selected from the <b>Search By</b> list.</p> </div> <div data-bbox="586 1528 1122 1717" style="border: 1px solid black; padding: 5px;"> <p><b>Note:</b> This field appears only when the following options are selected from the <b>Search By</b> list.</p> <ul style="list-style-type: none"> <li>• Registration Details</li> <li>• Inbound Message Details</li> </ul> </div>	No

Field Name	Field Description	Mandatory (Yes or No)
Customer Registration Type	<p>Used to search customer registrations which are created using a particular customer registration type.</p> <p><b>Note:</b> This field appears only when the <b>Registration Details</b> option is selected from the <b>Search By</b> list.</p>	No
Division	<p>Used to indicate the division using which you want to search a customer registration object.</p> <p><b>Note:</b> This field appears only when the <b>Person Details</b> option is selected from the <b>Search By</b> list. Additional search criterion is required when the <b>Division</b> option is selected for search.</p>	No
Person Name	<p>Used to specify the person name using which you want to search a customer registration object.</p> <p><b>Note:</b> This field appears only when the <b>Person Details</b> option is selected from the <b>Search By</b> list.</p>	No
Person ID	<p>Used to specify the person id using which you want to search a customer registration object.</p> <p><b>Note:</b> This field appears only when the <b>Person Details</b> option is selected from the <b>Search By</b> list.</p>	No

Field Name	Field Description	Mandatory (Yes or No)
Person Identifier Type	<p>Used to specify the person identifier type using which you want to search a customer registration object. The valid values are:</p> <ul style="list-style-type: none"> <li>• Bank Identifier Code</li> <li>• Base Global Customer ID</li> <li>• Company Registration Number</li> <li>• Customer ID</li> <li>• DDA</li> <li>• Deal Information</li> <li>• Drivers License</li> <li>• Employer Identity</li> <li>• Flexcube Customer ID</li> <li>• Franchise Code</li> <li>• GFCID</li> <li>• GFPID</li> <li>• Global Earnings Credit Distribution ID</li> <li>• Group ID</li> <li>• Memeber ID</li> <li>• Mothers maiden name</li> <li>• National Insurance</li> <li>• Social Insurance Number</li> <li>• Social Security Number</li> <li>• Taxpayer Identification Number</li> <li>• Web user id</li> </ul> <p><b>Note:</b> This field appears only when the <b>Person Details</b> option is selected from the <b>Search By</b> list.</p>	No
Person Identifier	<p>Used to specify the person identifier using which you want to search for a customer registration.</p> <p><b>Note:</b> This field appears only when the <b>Person Details</b> option is selected from the <b>Search By</b> list.</p>	Yes
Inbound Message ID	<p>Used to search a customer registration object by specifying the inbound message id.</p> <p><b>Note:</b> This field appears only when the <b>Inbound Message Details</b> option is selected from the <b>Search By</b> list.</p>	No



Field Name	Field Description	Mandatory (Yes or No)
Source System	Used to search a customer registration object whose information is received from a specified source system.  <b>Note:</b> This field appears only when the <b>Inbound Message Details</b> option is selected from the <b>Search By</b> list.	No
External Source ID	Used to search a customer registration object whose information is received from an external source id.  <b>Note:</b> This field appears only when the <b>Inbound Message Details</b> option is selected from the <b>Search By</b> list.	No
External Transaction ID	Used to search a customer registration object whose information is received from an external transaction id.  <b>Note:</b> This field appears only when the <b>Inbound Message Details</b> option is selected from the <b>Search By</b> list.	No
External Batch ID	Used to search a customer registration business object whose information is received from an external batch id.  <b>Note:</b> This field appears only when the <b>Inbound Message Details</b> option is selected from the <b>Search By</b> list.	No
Inbound Message Type	Used to indicate an inbound message type using which you want to search a customer registration object.  <b>Note:</b> This field appears only when the <b>Inbound Message Details</b> option is selected from the <b>Search By</b> list.	No
Request Id	Used to indicate the request id using which you want to search a customer registration object.  <b>Note:</b> This field appears only when the <b>File Upload Details</b> option is selected from the <b>Search By</b> list.	No
File Name	Used to indicate the file name using which you want to search a customer registration object.  <b>Note:</b> This field appears only when the <b>File Upload Details</b> option is selected from the <b>Search By</b> list.	No

Field Name	Field Description	Mandatory (Yes or No)
File Status	<p>Used to indicate the file status using which you want to search a customer registration object.</p> <ul style="list-style-type: none"> <li>• Approval Pending</li> <li>• Completed</li> <li>• Error</li> <li>• Pending</li> <li>• Rejected</li> </ul> <p><b>Note:</b> This field appears only when the <b>File Upload Details</b> option is selected from the <b>Search By</b> list.</p>	Yes
File Request Type	<p>Used to indicate the file request type using which you want to search a customer registration object.</p> <p><b>Note:</b> This field appears only when the <b>File Upload Details</b> option is selected from the <b>Search By</b> list.</p>	Yes

**Note:** You must specify at least one search criterion while searching for a customer registration object.

- **Search Results** - On clicking the **Search** button, the search results appear based on the specified search criteria. The **Search Results** section contains the following columns:

Column Name	Column Description
Create Date Time	Displays the date and time when the customer registration is created.
Customer Registration Information	<p>Displays information about the customer registration.</p> <p><b>Note:</b> It has a link. On clicking the link, the <b>Customer Registration</b> screen appears where you can view the details of the respective customer registration.</p> <p>This column appears only when the following options are selected from the <b>Search By</b> list.</p> <ul style="list-style-type: none"> <li>• Registration Details</li> <li>• Person Details</li> </ul>

Column Name	Column Description
Status	<p data-bbox="581 212 1089 237">Indicates the status of the customer registration.</p> <p data-bbox="581 260 805 285">The valid values are:</p> <ul data-bbox="610 308 938 716" style="list-style-type: none"> <li>• Approval In Progress</li> <li>• Bill Group Approved</li> <li>• Complete</li> <li>• Draft</li> <li>• Draft for Update</li> <li>• Parent Customer Approved</li> <li>• Pending Final Approval</li> <li>• Pending Pricing Correction</li> <li>• Rejected</li> </ul> <div data-bbox="581 737 1463 884" style="border: 1px solid black; padding: 5px; margin-top: 10px;"> <p data-bbox="581 745 646 770"><b>Note:</b></p> <p data-bbox="581 793 1463 856">These values appear only when the <b>Registration Details</b> option is selected from the <b>Search By</b> list.</p> </div> <p data-bbox="581 905 805 930">The valid values are:</p> <ul data-bbox="610 953 753 1163" style="list-style-type: none"> <li>• Pending</li> <li>• Processed</li> <li>• Rejected</li> <li>• Void</li> <li>• Voided</li> </ul> <div data-bbox="581 1184 1463 1331" style="border: 1px solid black; padding: 5px; margin-top: 10px;"> <p data-bbox="581 1192 646 1218"><b>Note:</b></p> <p data-bbox="581 1241 1463 1304">These values appear only when the <b>Inbound Message Details</b> option is selected from the <b>Search By</b> list.</p> </div> <div data-bbox="581 1352 1463 1640" style="border: 1px solid black; padding: 5px; margin-top: 10px;"> <p data-bbox="581 1360 1463 1423"><b>Note:</b> This column appears only when the following options are selected from the <b>Search By</b> list.</p> <p data-bbox="581 1446 805 1472">The valid values are:</p> <ul data-bbox="610 1495 919 1612" style="list-style-type: none"> <li>• Registration Details</li> <li>• Person Details</li> <li>• Inbound Message Details</li> </ul> </div>

Column Name	Column Description
Inbound Message Information	<p>Displays information about the inbound message.</p> <p><b>Note:</b> It has a link. On clicking the link, the <b>Inbound Message</b> screen appears where you can view the details of the respective customer registration.</p> <p>This column appears only when the <b>Inbound Message Details</b> option is selected from the <b>Search By</b> list.</p>
Inbound Message Type	<p>Displays the inbound message type in the customer registration.</p> <p><b>Note:</b> This column appears only when the <b>Inbound Message Details</b> option is selected from the <b>Search By</b> list.</p>
Source System	<p>Displays the source system of the customer registration.</p> <p><b>Note:</b> This column appears only when the <b>Inbound Message Details</b> option is selected from the <b>Search By</b> list.</p>
Person Information	<p>Displays the information of a person.</p>
Created By	<p>Indicates the user who has created the customer registration.</p> <p><b>Note:</b> This column appears only when the following options are selected from the <b>Search By</b> list.</p> <ul style="list-style-type: none"> <li>• Registration Details</li> <li>• Person Details</li> <li>• Inbound Message Details</li> </ul>
Person Name	<p>Displays the name of a person.</p> <p><b>Note:</b> This column appears only when the following options are selected from the <b>Search By</b> list.</p> <ul style="list-style-type: none"> <li>• Person Details</li> </ul>
Primary Person Identifier Type	<p>Displays the primary person identifier type.</p> <p><b>Note:</b> This column appears only when the following options are selected from the <b>Search By</b> list.</p> <ul style="list-style-type: none"> <li>• Person Details</li> </ul>
Primary Person Identifier	<p>Displays the primary person identifier.</p> <p><b>Note:</b> This column appears only when the following options are selected from the <b>Search By</b> list.</p> <ul style="list-style-type: none"> <li>• Person Details</li> </ul>

Column Name	Column Description
Request Id	Displays the request id of the customer registration.  <b>Note:</b> This column appears only when the following options are selected from the <b>Search By</b> list. <ul style="list-style-type: none"> <li>File Upload Details</li> </ul>
File ID	Displays the file id of the customer registration.  <b>Note:</b> This column appears only when the following options are selected from the <b>Search By</b> list. <ul style="list-style-type: none"> <li>File Upload Details</li> </ul>
File Name	Displays the file name of the customer registration.  <b>Note:</b> This column appears only when the following options are selected from the <b>Search By</b> list. <ul style="list-style-type: none"> <li>File Upload Details</li> </ul>
Request Type	Displays the request type of the customer registration.  <b>Note:</b> This column appears only when the following options are selected from the <b>Search By</b> list. <ul style="list-style-type: none"> <li>File Upload Details</li> </ul>
Copy	On clicking the <b>Copy</b> (  ) icon, the <b>Customer Registration</b> screen appears where you can define a new customer registration using an existing customer registration.

**Note:** Pagination is used to display limited number of records in the **Search Results** section. You can use the navigation links, such as **Previous** and **Next** to navigate between pages.

### Related Topics

For more information on...	See...
How to search for a customer registration	<a href="#">Searching a Customer Registration</a> on page 117

## Searching a Customer Registration

### Prerequisites

To search a customer registration, you should have:

- Customer registration statuses defined in the application
- Customer registration types defined in the application

### Procedure

To search a customer registration:

1. Click the **Menu** link in the **Application** toolbar.

A list appears.

- From the **Main** menu, select **Person Information** and then click **Customer Registration**.

A sub-menu appears.

- Click the **Search** option from the **Customer Registration** sub-menu.

The **Customer Registration** screen appears.

- Enter the search criteria in the **Search Customer Registration** zone.

**Note:** ORMB search engine supports wildcard search, where you can substitute the percentage (%) symbol as a stand in for any word or letter in a search criteria. You can use the ‘%’ wildcard character in all input fields except the date and ID fields. The ‘%’ wildcard character is suffixed automatically at the end of the partial search criteria. Therefore, you may or may not specify the wildcard character at the end of the partial search criteria. However, you have to prefix the wildcard character manually wherever required.

- Click **Search**.

A list of customer registrations that meet the search criteria appears in the **Search Results** section.

### Related Topics

For more information on...	See...
<b>Customer Registration</b> screen	<a href="#">Customer Registration (Used for Viewing)</a> on page 154
<b>Customer Registration</b> zone	<a href="#">Customer Registration</a>

## Viewing the Customer Registration Details

### Procedure

To view the details of a customer registration:

- Search for the customer registration in the **Customer Registration** screen.
- In the **Search Results** section, click the link in the **Customer Registration Information** column corresponding to the customer registration whose details you want to view:

The **Customer Registration** screen appears.

- Ensure that the **Main** tab is selected.
- View the details of the customer registration in the **Customer Registration** zone.

### Related Topics

For more information on...	See...
How to search for a customer registration	<a href="#">Searching a Customer Registration</a> on page 117
<b>Customer Registration</b> screen	<a href="#">Customer Registration (Used for Viewing)</a> on page 154
<b>Customer Registration</b> zone	<a href="#">Customer Registration</a>
<b>Account Information</b> zone	<a href="#">Account Information</a> on page 155
<b>Policies</b> zone	<a href="#">Policies</a> on page 158
<b>Parent Policies</b> zone	<a href="#">Parent Policies</a> on page 158

## Defining a Customer Registration

### Prerequisites

To define a customer Registration, you should have:

- Customer Registration Types defined in the application
- Source System defined in the application
- Person Types defined in the application
- Divisions defined in the application
- Customer Tier defined in the application
- Name Types defined in the application
- Phone Types defined in the application
- Person Identifier Types defined in the application
- Address Type Codes defined in the application
- Countries defined in the application
- Characteristic Types defined in the application
- Parent/Child defined in the application
- Relationship Types defined in the application
- Deal Review Frequencies defined in the application
- Currency Codes defined in the application
- Prospects defined in the application

### Procedure

To define a customer registration:

1. Click the **Menu** link in the **Application** toolbar.  
A list appears.
2. From the **Main** menu, select **Person Information** and then click **Customer Registration**.  
A sub-menu appears.
3. Click the **Add** option from the **Customer Registration** sub-menu.

The **Add Customer Registration** screen appears. It contains the following fields:

Field Name	Field Description	Mandatory (Yes or No)
Customer Registration Type	Used to indicate the customer registration type using which you want to create the customer registration.	Yes
Source System	Used to indicate the external system using which you want to create the customer registration.	No
Person Type	Used to indicate the person of a particular type using which you want to create the customer registration.	Yes

**Tip:** Alternatively, you can access the **Add Customer Registration** screen by clicking the **Add** button in the **Page Title** area of the **Customer Registration** screen.

4. Select the required **Customer Registration Type** from the respective field.
5. Select the required **Source System** from the respective field.
6. Select the required **Person Type** from the respective field.
7. Click **OK**.

The **Customer Registration** screen appears. It contains the following panels:

- Main
- Contact
- Person Characteristics
- Hierarchy
- Accounts
- Deal
- Registration Characteristics

The **Main** panel appears. It contains the following sections:

- **Person Name** - Used to indicate person names for the customer registration.
- **Person Phones**- Used to indicate person phones for the customer registration.
- **Person IDs**- Used to indicate person ids for the customer registration.

The **Main** section contains the following fields:

Field Name	Field Description	Mandatory (Yes or No)
Person Type	Used to indicate the type of a person.	Yes
Date of Birth	Used to indicate the date of birth.	No
Division	Used to indicate the division.	No
Person Since Date	Used to indicate the person since date.	No
Customer Segment	Used to indicate the customer segment.	No
Customer Tier	Used to indicate the customer tier.	No
Access Group	Used to indicate the access group.  The <b>Search</b>  icon appears corresponding to the <b>Access Group</b> field. On clicking the <b>Search</b> icon, you can search for a predefined access groups.	No

8. Enter the required details in the **Main** section.
9. Define names of a person, if required.
10. Define phone details for a person, if required.
11. Define identifier details for a person, if required.
12. Define addresses of a person in the **Contact** option, if required.
13. Define characteristics of a person in the **Person Characteristics**, if required.



14. Define hierarchy of a person in the **Hierarchy**, if required.
15. Define accounts in the **Accounts**, if required.
16. Define deal information in the **Deal**, if required.
17. Define registration characteristics in the **Registration Characteristics**, if required.
18. Click **Save**.

The customer registration is created.

### Related Topics

For more information on...	See...
Customer Registration screen	<a href="#">Customer Registration (Used for Viewing)</a> on page 154

## Adding the Names of a Person

### Prerequisites

To add the names of a person, you should have:

- Name type defined in the application.

### Procedure

To add the names of a person:

1. Ensure that the **Person Names** section is expanded when you are defining, editing, or copying a customer registration.

The **Person Names** section contains the following fields in a grid:

Field Name	Field Description	Mandatory (Yes or No)
Name Type	Used to indicate the type of name used for customer registration.  <b>Note:</b> The list includes only those name types where the name entity is set to <b>Customer Registration</b> .	Yes (Conditional)  <b>Note:</b> This field is required when you are adding a name for the customer registration.
Name	Used to specify the value for the person name.	Yes (Conditional)  <b>Note:</b> This field is required when you are adding a name for the customer registration.

2. Enter the required details in the **Person Names** section.
3. If you want to define more than one person name for the customer registration, click the **Add** (+) icon and then repeat step 2.

**Note:** However, if you want to remove a person name from the customer registration, click the **Delete** (🗑️) icon corresponding to the person name.

### Related Topics

For more information on...	See...
How to define a customer registration	<a href="#">Defining a Customer Registration</a> on page 119

For more information on...	See...
How to edit a customer registration	<a href="#">Editing the Customer Registration Details</a> on page 166
How to copy a customer registration	<a href="#">Copying a Customer Registration</a> on page 147

## Adding the Phone Details of a Person

### Prerequisites

To add the phone details of a person, you should have:

- Phone type defined in the application.

### Procedure

To add the phone details of a person:

1. Ensure that the **Person Phones** section is expanded when you are defining, editing, or copying a customer registration.

The **Person Phones** section contains the following fields in a grid:

Field Name	Field Description	Mandatory (Yes or No)
Phone Type	Used to indicate the phone type. The valid values are: <ul style="list-style-type: none"> <li>• Business</li> <li>• Business Phone</li> <li>• Fax</li> <li>• Home</li> <li>• Mobile</li> </ul> <p><b>Note:</b> The list includes only those phone types where the phone type entity is set to <b>Customer Registration</b>.</p>	Yes (Conditional) <b>Note:</b> This field is required when you are adding a phone details of a person.
Phone Number	Used to specify the value for the phone number.	Yes (Conditional) <b>Note:</b> This field is required when you are adding a phone details of a person.
Extension	Used to specify an extension value.	Yes (Conditional) <b>Note:</b> This field is required when you are adding a phone details of a person.
Phone Format	Displays the phone format.	Not applicable

2. Enter the required details in the **Person Phones** section.
3. If you want to define more than one person phone for the customer registration, click the **Add** (+) icon and then repeat step 2.

**Note:** However, if you want to remove a person phone from the customer registration, click the **Delete** (🗑️) icon corresponding to the person phone.

**Related Topics**

For more information on...	See...
How to define a customer registration	<a href="#">Defining a Customer Registration</a> on page 119
How to edit a customer registration	<a href="#">Editing the Customer Registration Details</a> on page 166
How to copy a customer registration	<a href="#">Copying a Customer Registration</a> on page 147

**Adding the Identifier Details of an Account****Prerequisites**

To add the identifier details of an account, you should have:

- Account Identifier Types defined in the application.

**Procedure**

To add the identifier details of an account:

1. Ensure that the **Account Identifiers** zone in the **Main** panel of the **Customer Registration - Add Accounts** screen is expanded when you are adding an account in the customer registration.

The **Account Identifiers** zone contains the following fields in a grid:

Field Name	Field Description	Mandatory (Yes or No)
Primary ID	Used to indicate whether the account identifier type and account identifier is of primary type.	Yes
Account Identifier Type	Used to indicate the account identifier type for an account.	Yes
Account Identifier	Used to specify the account identifier for the account identifier type.	Yes (Conditional) <b>Note:</b> This field is required when you are defining account identifier type.

**Note:** You must specify at least one primary identifier while adding identifier details of an account.

2. Enter the required details in the **Account Identifiers** section.
3. If you want to define more than one account identifier for an account, click the **ADD** (+) icon and then repeat step 2.

**Note:** However, if you want to remove an account identifier from an account, click the **Delete** (🗑️) icon corresponding to the account identifier.

**Related Topics**

For more information on...	See...
How to define a customer registration	<a href="#">Defining a Customer Registration</a> on page 119
How to edit a customer registration	<a href="#">Editing the Customer Registration Details</a> on page 166
How to copy a customer registration	<a href="#">Copying a Customer Registration</a> on page 147

## Adding the Contact Details of a Person

### Prerequisites

To add the contact details of a person, you should have:

- Address Type code defined in the application.
- Country defined in the application.

### Procedure

To add the contact details of a person:

1. Ensure that the **Person Addresses** section in the **Contact** panel is expanded when you are defining, editing, or copying a customer registration.

The **Person Addresses** section contains the following fields in a grid:

Field Name	Field Description	Mandatory (Yes or No)
Address Type Code	Used to indicate the code of the address type which is used for registering the customer's contact details.  <b>Note:</b> The list includes only those address type codes where the address type code entity is set to <b>Customer Registration</b> .	Yes (Conditional)  <b>Note:</b> This field is required when you are adding contact details of a person.
Country	Used to indicate the country to which the customer belongs.	Yes (Conditional)  <b>Note:</b> This field is required when you are adding contact details of a person.
Override Mailing Name - Name1	Used to specify the first name of the mailer.	Yes (Conditional)  <b>Note:</b> This field is required when you are adding contact details of a person.
Override Mailing Name - Name2	Used to specify the second name of the mailer.	Yes (Conditional)  <b>Note:</b> This field is required when you are adding contact details of a person.
Override Mailing Name - Name3	Used to specify the last name of the mailer.	Yes (Conditional)  <b>Note:</b> This field is required when you are adding contact details of a person.
Email Address	Used to specify the email address of the customer.	Yes (Conditional)  <b>Note:</b> This field is required when you are adding contact details of a person.

2. Enter the required details in the **Person Addresses** zone of the **Contact** panel.

### Related Topics

For more information on...	See...
How to define a customer registration	<a href="#">Defining a Customer Registration</a> on page 119
How to edit a customer registration	<a href="#">Editing the Customer Registration Details</a> on page 166
How to copy a customer registration	<a href="#">Copying a Customer Registration</a> on page 147

## Defining a Characteristic for a Person

### Prerequisites

To define a characteristic for a person, you should have:

- Characteristic types defined in the application (where the characteristic entity is set to **Customer Registration**)

### Procedure

To define a characteristic for a person:

1. Ensure that the **Characteristics** zone of the **Person Characteristics** panel is expanded when you are defining a customer registration.

The **Characteristics** zone contains the following fields in a grid:

Field Name	Field Description	Mandatory (Yes or No)
Effective Date	Used to specify the date from when the characteristic is effective for the customer registration.	Yes (Conditional) <b>Note:</b> This field is required when you are defining a characteristic for the customer registration.
Characteristic Type	Used to indicate the characteristic type. <b>Note:</b> The list includes only those characteristic types where the characteristic entity is set to <b>Customer Registration</b> .	Yes (Conditional) <b>Note:</b> This field is required when you are defining a characteristic for the customer registration.
Characteristic Value	Used to specify the value for the characteristic type. <b>Note:</b> If you select a predefined characteristic type, the <b>Search</b>  icon appears corresponding to the <b>Characteristic Value</b> field. On clicking the <b>Search</b> icon, you can search for a predefined characteristic value.  On specifying the value for a predefined characteristic type, the description of the characteristic value appears corresponding to the <b>Characteristic Value</b> field.	Yes (Conditional) <b>Note:</b> This field is required when you are defining a characteristic for the customer registration.

2. Enter the required details in the **Characteristics** zone.

3. If you want to define more than one characteristic for the customer registration, click the **Add (+)** icon and then repeat step 2.

**Note:** However, if you want to remove a characteristic from the customer registration, click the **Delete (🗑)** icon corresponding to the characteristic.

### Related Topics

For more information on...	See...
How to edit a customer registration	<a href="#">Editing the Customer Registration Details</a> on page 166

## Defining a Person to Person Relationship

### Prerequisites

To define a person to person relationship, you should have:

- Parent/Child defined in the application (where the Parent/Child entity is set to **Customer Registration**).
- Relationship type defined in the application.

### Procedure

To define a person to person relationship, you should have:

1. Ensure that the **Related Person Information** zone of the **Hierarchy** panel is expanded when you are defining a customer registration.

The **Related Person Information** zone contains the following fields in a grid:

Field Name	Field Description	Mandatory (Yes or No)
Related Person ID	Used to specify the related person ID.  The <b>Search (🔍)</b> icon appears corresponding to the <b>Related Person ID</b> field. On clicking the <b>Search</b> icon, you can search for a predefined person IDs.	Yes (Conditional)  <b>Note:</b> This field is required when you are defining a related person Id for the customer registration.
Parent/Child	Used to indicate the parent/child. The valid values are: <ul style="list-style-type: none"> <li>• Parent</li> <li>• Child</li> </ul>	Yes (Conditional)  <b>Note:</b> This field is required when you are defining parent/child.
Relationship Type	Used to indicate the relationship type of a person.	Yes (Conditional)  <b>Note:</b> This field is required when you are defining a relationship type for the customer registration.
Start Date	Used to indicate the start date.	Yes (Conditional)  <b>Note:</b> This field is required when you are defining a start date for the customer registration.

Field Name	Field Description	Mandatory (Yes or No)
End Date	Used to indicate the end date.	Yes (Conditional) <b>Note:</b> This field is required when you are defining a end date for the customer registration.
Financial Relationship	Used to indicate the financial relationship	Yes (Conditional) <b>Note:</b> This field is required when you are defining a financial relationship for the customer registration.
Characteristics	On clicking the <b>Add (+)</b> icon, you can add characteristic type and its respective value.	Yes (Conditional) <b>Note:</b> This field is required when you are defining a characteristic for the customer registration.

- Enter the required details in the **Related Person Information** zone.
- If you want to define more than one characteristic for the customer registration, click the **Add (+)** icon and then repeat step 2.

**Note:** However, if you want to remove a characteristic from the customer registration, click the **Delete (🗑)** icon corresponding to the characteristic.

### Related Topics

For more information on...	See...
How to edit a customer registration	<a href="#">Editing the Customer Registration Details</a> on page 166

## Defining a Characteristic for a Person to Person Relationship

### Prerequisites

To define a characteristic for a person to person relationship, you should have:

- Characteristic types defined in the application (where the characteristic entity is set to **Customer Registration**)

### Procedure

To define a characteristic for a person to person relationship:

- Ensure that the **Related Person Information** zone of the **Hierarchy** panel is expanded when you are defining a customer registration.

The **Related Person Information** zone contains the following fields in a grid:

Field Name	Field Description	Mandatory (Yes or No)
Effective Date	Used to specify the date from when the characteristic is effective for the customer registration.	Yes (Conditional) <b>Note:</b> This field is required when you are defining a effective date for the customer registration.

Field Name	Field Description	Mandatory (Yes or No)
Characteristic Type	Used to indicate the characteristic type.  <b>Note:</b> The list includes only those characteristic types where the characteristic entity is set to <b>Customer Registration</b> .	Yes (Conditional)  <b>Note:</b> This field is required when you are defining a characteristic type for the customer registration.
Characteristic Value	Used to specify the value for the characteristic type.	Yes (Conditional)  <b>Note:</b> This field is required when you are defining a characteristic value for the customer registration.

- Enter the required details in the **Related Person Information** zone.
- If you want to define more than one characteristic for the customer registration, click the **Add** (+) icon and then repeat step 2.

**Note:** However, if you want to remove a characteristic from the customer registration, click the **Delete** (🗑️) icon corresponding to the characteristic.

### Related Topics

For more information on...	See...
How to edit a customer registration	<a href="#">Editing the Customer Registration Details</a> on page 166

## Adding an Account for a Person

### Prerequisites

To add the account for a person, you should have:

- Customer class defined in the application.
- Divisions defined in the application.
- Invoice currency defined in the application.
- Account categories defined in the application.
- Access Group defined in the application.
- Product defined in the application.
- Bill Cycle defined in the application.
- Account Identifier Types defined in the application.

### Procedure

To add an account for a person:

1. Ensure that the **Accounts** zone in the **Accounts** panel is expanded when you are defining, editing, or copying a customer registration.

The **Accounts** zone contains the following fields in a grid:



Field Name	Field Description	Mandatory (Yes or No)
Sequence No.	Used to indicate the sequence number.	Not applicable
Template	Displays the template for an account	Not applicable
Customer Class	Displays the customer class for an account.	Not applicable
Division	Displays the division for an account.	Not applicable
Primary Identifier Type	Displays the primary identifier type.	Not applicable
Identifier Value	Displays the identifier value.	Not applicable
View / Edit	On clicking the <b>View / Edit</b>  icon, the <b>Customer Registration - Add Account</b> screen appears where you can add or modify the account details of a customer.	No

2. Click the **Add New Account** button in the **Accounts** zone.

The **Customer Registration - Add Account** screen appears. It contains the following fields:

Field Name	Field Description	Mandatory (Yes or No)
Customer Class	Used to indicate the customer class for the customer registration.	Yes
Division	Used to indicate the division for the customer registration.	Yes
Set Up Date	Used to indicate the set up date for the customer registration.	No
Invoice Currency	Used to indicate the invoice currency for the customer registration.	Yes
Account Category	Used to indicate the account category for the customer registration.	No
Access Group	Used to indicate the access group for the customer registration.  <div style="border: 1px solid black; padding: 5px; margin-top: 10px;"> <p><b>Note:</b> The <b>Search</b>  icon appears corresponding to the <b>Access Group</b> field. On clicking the <b>Search</b> icon, you can search for a predefined access groups.</p> </div>	Yes
Exclude Accrual	Used to indicate that accrual is excluded from the customer registration.	No

Field Name	Field Description	Mandatory (Yes or No)
Accrual Cycle	Used to indicate the accrual cycle is included in the customer registration.	No
Product	Used to indicate the product is defined for the customer registration.  <div style="border: 1px solid black; padding: 5px; margin: 5px 0;"> <b>Note:</b> The Search  icon appears corresponding to the <b>Access Group</b> field. On clicking the <b>Search</b> icon, you can search for a predefined products. </div>	No
Eligible for Repricing	Used to indicate whether the account is eligible for repricing in the customer registration.	No
Bill Cycle	Used to indicate the bill cycle for an account.	No
Bill Lead Days	Used to specify the bill lead days for an account.	No
Comments	Used to specify the comments for an account.	No

3. Enter the required details in the **Main** panel of the **Customer Registration - Add Account** screen.
4. Define the account identifiers for an account.
5. Define the autopay details in the **Autopay** , if required.
6. define the details of a person in the **Persons** panel, if required.
7. Define, edit, or remove characteristics from the **Account Characteristics** panel, if required.
8. Click the **Next** button to continue adding the account details for a person.
9. Click the **Save as Draft** button to save the account details as a draft for a person.
10. Click the **Validate and Save** button to validate the account details of a person.

#### **Related Topics**

For more information on...	See...
How to define a customer registration	<a href="#">Defining a Customer Registration</a> on page 119
How to edit a customer registration	<a href="#">Editing the Customer Registration Details</a> on page 166
How to copy a customer registration	<a href="#">Copying a Customer Registration</a> on page 147

## **Adding the Identifier Details of an Account**

### **Prerequisites**

To add the identifier details of an account, you should have:

- Account Identifier Types defined in the application.

### **Procedure**

To add the identifier details of an account:

1. Ensure that the **Account Identifiers** zone in the **Main** panel of the **Customer Registration - Add Accounts** screen is expanded when you are adding an account in the customer registration.

The **Account Identifiers** zone contains the following fields in a grid:

Field Name	Field Description	Mandatory (Yes or No)
Primary ID	Used to indicate whether the account identifier type and account identifier is of primary type.	Yes
Account Identifier Type	Used to indicate the account identifier type for an account.	Yes
Account Identifier	Used to specify the account identifier for the account identifier type.	Yes (Conditional) <b>Note:</b> This field is required when you are defining account identifier type.

**Note:** You must specify at least one primary identifier while adding identifier details of an account.

2. Enter the required details in the **Account Identifiers** section.
3. If you want to define more than one account identifier for an account, click the **ADD (+)** icon and then repeat step 2.

**Note:** However, if you want to remove an account identifier from an account, click the **Delete (🗑)** icon corresponding to the account identifier.

### Related Topics

For more information on...	See...
How to define a customer registration	<a href="#">Defining a Customer Registration</a> on page 119
How to edit a customer registration	<a href="#">Editing the Customer Registration Details</a> on page 166
How to copy a customer registration	<a href="#">Copying a Customer Registration</a> on page 147

## Adding Automatic Payment Details of an Account



### Procedure

To add automatic payment details of an account:

1. Ensure that the **Auto Pay** panel is expanded when you are defining, editing, or copying a customer registration.

The **Auto Pay** option contains the following fields in a grid:

Field Name	Field Description	Mandatory (Yes or No)
Defer Auto Pay Date	Used to indicate the defer auto pay date.	No
Rule Based Auto Pay	Used to indicate whether the rule based auto pay option is enabled.	No
Start Date	Used to indicate the start date from when the auto pay is effective.	No

Field Name	Field Description	Mandatory (Yes or No)
End Date	Used to indicate the end date till when the auto pay is effective.	No
Percentage	Used to specify the percentage for auto pay.	No
Priority	Used to specify the priority for auto pay.	No
Auto Pay Source Code	Used to indicate the source of funds used to make the automatic payment. For example, debit card or credit card.  <b>Note:</b> The <b>Search</b>  icon appears corresponding to the <b>Auto Pay Source Code</b> field. On clicking the <b>Search</b> icon, you can search for a predefined auto pay source code.	No
Auto Pay Route Type	Used to indicate the auto pay route type.  <b>Note:</b> The <b>Search</b>  icon appears corresponding to the <b>Auto Pay Route Type</b> field. On clicking the <b>Search</b> icon, you can search for a predefined auto pay source code.	No
Account Number	Used to specify the account number.	No
Expires On	Used to indicate the date on which the auto payment expires.	No
Name	Used to specify the account name for auto pay.	No
Maximum Withdrawal Amount	Used to specify the maximum amount which can be withdrawn from an account.	No
Comments	Used to specify the comments for an account.	No

2. Enter the required details in the **Auto pay** panel.
3. Click **Next** to continue adding an account for a person.
4. Click **Save as Draft** to save the details as a draft to add automatic payment details of an account.
5. Click **Validate and Save** to validate and save the details.

### **Related Topics**

For more information on...	See...
How to define a customer registration	<a href="#">Defining a Customer Registration</a> on page 119
How to edit a customer registration	<a href="#">Editing the Customer Registration Details</a> on page 166
How to copy a customer registration	<a href="#">Copying a Customer Registration</a> on page 147

## **Associating a Person to an Account**

### **Procedure**

To associate a person to an account:

1. Ensure that the **Persons** panel in the **Customer Registration - Add Account** is expanded when you are defining, editing, or copying a customer registration.

The **Persons** panel contains the following fields in a grid:

Field Name	Field Description	Mandatory (Yes or No)
Person ID	Used to specify the person id.  <b>Note:</b> The <b>Search</b> (🔍) icon appears corresponding to the <b>Person ID</b> field. On clicking the <b>Search</b> icon, you can search for a predefined person.	No
Person Name	Displays a person name.	Not applicable
Main Customer	Used to indicate whether the person is the main customer.	No
Financially Responsible	Used to indicate whether the person is financially responsible.	No
Account Relationship Type	Used to indicate the account relationship type. The valid values are: <ul style="list-style-type: none"> <li>• Account Holder</li> <li>• Account Manager</li> <li>• Accountant</li> <li>• Broker</li> <li>• Bulk Mailing Contact</li> <li>• Coborrower</li> <li>• Guarantor</li> <li>• Mail Recipient</li> <li>• Mailing Bundle</li> <li>• Mailing Location</li> <li>• Main Customer</li> <li>• Producer</li> <li>• Spouse</li> <li>• Third Party</li> </ul>	No

2. Enter the required details in the **Persons** panel.
3. Enter the required details in the **Bill Routing Information** section.
4. Click **Next** to continue adding an account for a person.
5. Click **Save as Draft** to save the details as a draft to add automatic payment details of an account.
6. Click **Validate and Save** to validate and save the details.

#### **Related Topics**

For more information on...	See...
How to define a customer registration	<a href="#">Defining a Customer Registration</a> on page 119

For more information on...	See...
How to edit a customer registration	<a href="#">Editing the Customer Registration Details</a> on page 166
How to copy a customer registration	<a href="#">Copying a Customer Registration</a> on page 147

## Adding Bill Routing Information for an Account

### Procedure

To add bill routing information for an account:

1. Ensure that **Bill Routing Information** section is expanded when you are adding the bill routing information for an account.

The **Persons** option contains the following fields in a grid:

Field Name	Field Description	Mandatory (Yes or No)
Receives Copy of Bill	Used to indicate whether the customer should receive the copy of a bill.	No
Bill Format	Used to indicate the format of the bill.	No
Address Source	Used to indicate the address source.	No
Number of Bill Copies	Used to specify the number of bill copies.	No
Bill Route Type	Used to indicate the bill route type.	No
Receives Notification	Used to indicate whether the customer should receive notifications.	No

2. Enter the required details in the **Bill Routing Information** zone.
3. Click **Next** to continue adding the bill routing information for an account.
4. Click **Save as Draft** to save the details as a draft to add bill routing information for an account.
5. Click **Validate and Save** to validate and save the details.

### Related Topics

For more information on...	See...
How to define a customer registration	<a href="#">Defining a Customer Registration</a> on page 119
How to edit a customer registration	<a href="#">Editing the Customer Registration Details</a> on page 166
How to copy a customer registration	<a href="#">Copying a Customer Registration</a> on page 147

## Defining a Characteristic for an Account

### Prerequisites

To define a characteristic for an account, you should have:

- Characteristic types defined in the application (where the characteristic entity is set to **Customer Registration**)

### Procedure

To define a characteristic for an account:

1. Ensure that the **Characteristics** zone in the **Account Characteristics** panel is expanded when you are defining a customer registration.

The **Characteristics** zone contains the following fields in a grid:

Field Name	Field Description	Mandatory (Yes or No)
Effective Date	Used to specify the date from when the characteristic is effective for the customer registration.	Yes (Conditional) <b>Note:</b> This field is required when you are defining a characteristic for the customer registration.
Characteristic Type	Used to indicate the characteristic type. <b>Note:</b> The list includes only those characteristic types where the characteristic entity is set to <b>Customer Registration</b> .	Yes (Conditional) <b>Note:</b> This field is required when you are defining a characteristic for the customer registration.
Characteristic Value	Used to specify the value for the characteristic type. <b>Note:</b> If you select a predefined characteristic type, the <b>Search</b> (🔍) icon appears corresponding to the <b>Characteristic Value</b> field. On clicking the <b>Search</b> icon, you can search for a predefined characteristic value.  On specifying the value for a predefined characteristic type, the description of the characteristic value appears corresponding to the <b>Characteristic Value</b> field.	Yes (Conditional) <b>Note:</b> This field is required when you are defining a characteristic for the customer registration.

- Enter the required details in the **Characteristics** zone.
- If you want to define more than one characteristic for the customer registration, click the **Add** (+) icon and then repeat step 2.

**Note:** However, if you want to remove a characteristic from the customer registration, click the **Delete** (🗑️) icon corresponding to the characteristic.

### Related Topics

For more information on...	See...
How to edit a customer registration	<a href="#">Editing the Customer Registration Details</a> on page 166

## Defining a Policy

### Prerequisites

To add the policy information, you should have:

- The **Customer Registration Type** should be selected as **Healthcare**.



- Policy types defined in the application.
- Source system defined in the application.
- Policy person role defined in the application.

### **Procedure**

To define a policy:

1. Ensure that the **Policies & Plans** zone in the **Policies** panel is expanded when you are defining, editing, or copying a policy for customer registration.

The **Policies & Plans** zone contains the following fields in a grid:

Field Name	Field Description	Mandatory (Yes or No)
Sequence No.	Displays the sequence number.	No
Template	Displays the selected template.	No
Policy Type	Displays the type of policy.	Yes
Policy Number	Displays the policy number.	No
View / Edit	On clicking the <b>View / Edit</b>  icon, the <b>Select Policy Type</b> screen appears where you can view or modify the policy and plans in customer registration.	No
Policy Plans	On clicking the <b>Add</b>  icon, you can add plan number and its respective detail.	No

2. Enter the required details in the **Policies & Plans** zone of the **Policies** panel.
3. Click the **Add New Policy** button from the **Policies & Plans** zone.

The **Select Policy Types** screen appears. It contains the following fields:

Field Name	Field Description	Mandatory (Yes or No)
Policy Type	Used to indicate the policy type using which you want to define a new policy.	Yes

4. Select the required **Policy Type** from the respective field.
5. Click **OK**.

The **Policy** screen appears. It contains the following sections:

- **Main** - Used to indicate basic details about policy for the customer registration.
- **Persons**- Used to indicate person details for the customer registration.
- **Characteristics**- Used to indicate characteristic for the customer registration.

The **Main** section contains the following fields:

Field Name	Field Description	Mandatory (Yes or No)
Person Type	Displays the type of person .	Not applicable
Policy Number	Used to specify the policy number.	Yes



Field Name	Field Description	Mandatory (Yes or No)
Description	Used to specify the description of the policy.	No
Source System	Used to indicate the source system of the policy.	Yes
Start Date	Used to indicate the start date of the policy.	Yes
End Date	Used to indicate the end date of the policy.	Yes
Policy Person Role	Used to indicate the policy person role.	No

6. Enter the required details in the **Main** section.
7. Define person details in the **Persons** section, if required.
8. Define characteristics in the **Characteristics** section, if required.
9. Click **Save as Draft** to save as draft.
10. Click **Validate and Save** to validate and save details to define a new policy.

### Related Topics

For more information on...	See...
How to define a customer registration	<a href="#">Defining a Customer Registration</a> on page 119
How to edit a customer registration	<a href="#">Editing the Customer Registration Details</a> on page 166
How to copy a customer registration	<a href="#">Copying a Customer Registration</a> on page 147

## Associating a Person to Policy

### Prerequisites

To associate a person to a policy, you should have:

- Characteristic types defined in the application (where the characteristic entity is set to **Customer Registration**)

### Procedure

To associate a person to a policy:

1. Ensure that the **Customer Registration** screen is opened when you are defining, editing, or copying a customer registration.
2. Ensure that the **Add/Edit Policy** screen is opened using the **Add New Policy** button from the **Policies & Plans** zone of the **Policies** panel.
3. Ensure that the **Persons** zone is expanded.

The **Persons** zone contains the following fields in a grid:

Field Name	Field Description	Mandatory (Yes or No)
Persons	Used to indicate the person. The <b>Search</b>  icon appears corresponding to the <b>Person</b> field. On clicking the <b>Search</b> icon, you can search for a predefined persons.	Yes (Conditional) <b>Note:</b> This field is required when you are associating persons to policy.

Field Name	Field Description	Mandatory (Yes or No)
Sequence	Used to specify the sequence number.	Yes (Conditional) <b>Note:</b> This field is required when you are associating persons to policy.
Policy Person Role	Used to indicate role of the policy person.	Yes (Conditional) <b>Note:</b> This field is required when you are associating persons to policy.
Main Customer	Used to indicate whether the person is main customer.	Yes (Conditional) <b>Note:</b> This field is required when you are associating persons to policy.
Start Date	Used to indicate the start date of policy.	Yes (Conditional) <b>Note:</b> This field is required when you are associating persons to policy.
End Date	Used to indicate the end date of policy.	Yes (Conditional) <b>Note:</b> This field is required when you are associating persons to policy.

- Enter the required details in the **Persons** section.
- Click **Save as Draft** to save the details as a draft to associate person to a policy.
- Click **Validate and Save** to validate and save the details.

#### Related Topics

For more information on...	See...
How to define a customer registration	<a href="#">Defining a Customer Registration</a> on page 119
How to edit a customer registration	<a href="#">Editing the Customer Registration Details</a> on page 166
How to copy a customer registration	<a href="#">Copying a Customer Registration</a> on page 147

## Defining a Characteristic for a Policy

### Prerequisites

To add the characteristic for a policy, you should have:

- The **Customer Registration Type** should be selected as **Healthcare**.
- Characteristic types defined in the application (where the characteristic entity is set to **Customer Registration**)

### Procedure

To define a characteristic for a policy:

- Ensure that the **Characteristics** zone in the **Policy** screen is expanded when you are defining, editing, or copying a customer registration.

The **Characteristics** zone contains the following fields in a grid:

Field Name	Field Description	Mandatory (Yes or No)
Effective Date	Used to specify the date from when the characteristic is effective for the customer registration.	Yes (Conditional) <b>Note:</b> This field is required when you are defining a characteristic for the customer registration.
Characteristic Type	Used to indicate the characteristic type. <b>Note:</b> The list includes only those characteristic types where the characteristic entity is set to <b>Customer Registration</b> .	Yes (Conditional) <b>Note:</b> This field is required when you are defining a characteristic for the customer registration.
Characteristic Value	Used to specify the value for the characteristic type. <b>Note:</b> If you select a predefined characteristic type, the <b>Search</b> (🔍) icon appears corresponding to the <b>Characteristic Value</b> field. On clicking the <b>Search</b> icon, you can search for a predefined characteristic value.  On specifying the value for a predefined characteristic type, the description of the characteristic value appears corresponding to the <b>Characteristic Value</b> field.	Yes (Conditional) <b>Note:</b> This field is required when you are defining a characteristic for the customer registration.

- Enter the required details in the **Characteristics** zone.
- If you want to define more than one characteristic for the customer registration, click the **Add** (+) icon and then repeat step 2.

**Note:** However, if you want to remove a characteristic from the customer registration, click the **Delete** (🗑️) icon corresponding to the characteristic.

### Related Topics

For more information on...	See...
How to edit a customer registration	<a href="#">Editing the Customer Registration Details</a> on page 166

## Adding a Plan in Policy

### Prerequisites

To add a plan in policy, you should have:

- Template defined in the application.

- Business Object defined in the application.
- Price Items defined in the application.

### **Procedure**

To add a plan in a policy:

1. Ensure that the **Policies & Plans** zone in the **Policies** panel is expanded when you are defining, editing, or copying a customer registration.

The **Policies & Plans** zone contains the following fields in a grid:

Field Name	Field Description	Mandatory (Yes or No)
Sequence No.	Used to specify the sequence number.	No
Template	Displays the selected template.	No
Policy Type	Displays the type of the policy.	Yes
Policy Number	Displays the policy number.	No
View / Edit	On clicking the <b>View / Edit</b> (✎) icon, the <b>Select Policy Type</b> screen appears where you can view or edit the details of a policy.	No
Policy Plans	On clicking the <b>Add</b> (📄+) icon, a grid appears which allows you to add, edit, and delete plan details for a policy.	No

2. Enter the required details in the **Policies & Plans** zone of the **Policies** panel which displays the policy information.
3. Click the **Add** (+) icon from the **Policy Plans** column to add a new plan for a policy.

A grid appears. It contains the following fields:

Field Name	Field Description	Mandatory (Yes or No)
Sequence No.	Displays the sequence no.	Yes
Template	Indicates the selected template.	Yes
Plan Number	Displays the plan number for the plan.	Yes
Price Item	Displays the price item for the plan.	Yes
View / Edit	On clicking the <b>View / Edit</b> (✎) icon, you can add template, plan number and its respective price item details.	No

4. Click the **Add New Plan** button.

A **Select Policy Plan Template** screen appears. It contains the following fields:

Field Name	Field Description	Mandatory (Yes or No)
Template	Used to indicate the template.	Yes

Field Name	Field Description	Mandatory (Yes or No)
Business Object	Used to indicate the business object using which you want to add new plan.	Yes

5. Click **OK**.

A **Add/Edit Policy Plan** screen appears. It contains the following sections:

- **Main** - Used to indicate basic details about policy plan.
- **Pricing Rule Type**- Used to indicate pricing rule type details for the customer registration.
- **Characteristics**- Used to indicate characteristic for the customer registration.

The **Main** section contains the following fields:

Field Name	Field Description	Mandatory (Yes or No)
Price Item	Used to indicate the price item.  <div style="border: 1px solid black; padding: 5px;"> <p><b>Note:</b> The <b>Search</b>  icon appears corresponding to the <b>Price Item</b> field. On clicking the <b>Search</b> icon, you can search for a predefined price items. The selected Price Item appears besides the <b>Price Item</b>field.</p> </div>	Not applicable
Plan Number	Used to specify the plan number.	Yes
Plan Name	Used to specify the plan name.	No
Start Date	Used to indicate the start date of plan.	Yes
End Date	Used to indicate the end date of plan.	Yes

6. Enter the required details in the **Main** section.
7. Enter the required details in the **Pricing Rule Type** section.
8. Enter the required details in the **Characteristics** section.
9. Click **Save as Draft** to save the details as a draft to add a plan to the policy.
10. Click **Validate and Save** to validate and save the details.

#### Related Topics

For more information on...	See...
How to define a customer registration	<a href="#">Defining a Customer Registration</a> on page 119
How to edit a customer registration	<a href="#">Editing the Customer Registration Details</a> on page 166
How to copy a customer registration	<a href="#">Copying a Customer Registration</a> on page 147

## Associating a Pricing Rule Type with a Policy Plan

### Prerequisites

To associate a pricing rule type with a policy plan, you should have:

- Pricing rule types defined in the application.

**Procedure**

To associate a pricing rule type with a policy plan:

1. Ensure that the **Pricing Rule Type** section of the **Add/Edit Policy Plan** screen in the **Policies** panel is expanded when you are defining, editing, or copying a customer registration.

The **Pricing Rule Type** section contains the following field in a grid:

Field Name	Field Description	Mandatory (Yes or No)
Pricing Rule Type	Used to indicate the pricing rule type.  <b>Note:</b> The Search (🔍) icon appears corresponding to the <b>Pricing Rule Type</b> field. On clicking the Search icon, you can search for a predefined pricing rule types.	Yes (Conditional)  <b>Note:</b> This field is required when you are defining a pricing rule type to associate pricing rule type with the policy plan.

2. Enter the required details in the **Pricing Rule Type** zone in the **Add/Edit Policy Plan** of the **Policies** panel.
3. If you want to define more than one characteristic for the customer registration, click the **Add** (+) icon and then repeat step 2.

**Note:** However, if you want to remove a characteristic from the customer registration, click the **Delete** (🗑️) icon corresponding to the characteristic.

4. Click **Save as Draft** to save the details as a draft to add a plan to the policy.
5. Click **Validate and Save** to validate and save the details.

**Related Topics**

For more information on...	See...
How to define a customer registration	<a href="#">Defining a Customer Registration</a> on page 119
How to edit a customer registration	<a href="#">Editing the Customer Registration Details</a> on page 166
How to copy a customer registration	<a href="#">Copying a Customer Registration</a> on page 147

**Defining a Characteristic for a Policy Plan****Prerequisites**

To define a characteristic for a policy plan, you should have:

- Characteristic types defined in the application (where the characteristic entity is set to **Customer Registration**)

**Procedure**

To define a characteristic for a policy plan:

1. Ensure that the **Characteristics** section of the **Add/Edit Policy Plan** screen in the **Policies** panel is expanded when you are defining, editing, or copying a customer registration.

The **Characteristics** section contains the following fields in a grid:

Field Name	Field Description	Mandatory (Yes or No)
Effective Date	Used to specify the date from when the characteristic is effective for the customer registration.	Yes (Conditional) <b>Note:</b> This field is required when you are defining a characteristic for the customer registration.
Characteristic Type	Used to indicate the characteristic type. <b>Note:</b> The list includes only those characteristic types where the characteristic entity is set to <b>Customer Registration</b> .	Yes (Conditional) <b>Note:</b> This field is required when you are defining a characteristic for the customer registration.
Characteristic Value	Used to specify the value for the characteristic type. <b>Note:</b> If you select a predefined characteristic type, the <b>Search</b>  icon appears corresponding to the <b>Characteristic Value</b> field. On clicking the <b>Search</b> icon, you can search for a predefined characteristic value.  On specifying the value for a predefined characteristic type, the description of the characteristic value appears corresponding to the <b>Characteristic Value</b> field.	Yes (Conditional) <b>Note:</b> This field is required when you are defining a characteristic for the customer registration.

- Enter the required details in the **Characteristics** section in the **Add/Edit Policy Plan** screen of the **Policies** panel.
- If you want to define more than one characteristic for the customer registration, click the **Add**  icon and then repeat step 2.

**Note:** However, if you want to remove a characteristic from the customer registration, click the **Delete**  icon corresponding to the characteristic.

- Click **Save as Draft** to save the details as a draft to add a plan to the policy.
- Click **Validate and Save** to validate and save the details.

### Related Topics

For more information on...	See...
How to define a customer registration	<a href="#">Defining a Customer Registration</a> on page 119
How to edit a customer registration	<a href="#">Editing the Customer Registration Details</a> on page 166
How to copy a customer registration	<a href="#">Copying a Customer Registration</a> on page 147

## Defining a Characteristic for Customer Registration

### Prerequisites

To define a characteristic for customer registration, you should have:

- Characteristic types defined in the application (where the characteristic entity is set to **Customer Registration**)

### Procedure

To define a characteristic for a person:

1. Ensure that the **Characteristics** zone of the **Registration Characteristics** panel is expanded when you are defining a customer registration.

The **Characteristics** zone contains the following fields in a grid:

Field Name	Field Description	Mandatory (Yes or No)
Effective Date	Used to specify the date from when the characteristic is effective for the customer registration.	Yes (Conditional) <b>Note:</b> This field is required when you are defining a characteristic for the customer registration.
Characteristic Type	Used to indicate the characteristic type. <b>Note:</b> The list includes only those characteristic types where the characteristic entity is set to <b>Customer Registration</b> .	Yes (Conditional) <b>Note:</b> This field is required when you are defining a characteristic for the customer registration.
Characteristic Value	Used to specify the value for the characteristic type. <b>Note:</b> If you select a predefined characteristic type, the <b>Search</b> (🔍) icon appears corresponding to the <b>Characteristic Value</b> field. On clicking the <b>Search</b> icon, you can search for a predefined characteristic value.  On specifying the value for a predefined characteristic type, the description of the characteristic value appears corresponding to the <b>Characteristic Value</b> field.	Yes (Conditional) <b>Note:</b> This field is required when you are defining a characteristic for the customer registration.

2. Enter the required details in the **Characteristics** zone.
3. If you want to define more than one characteristic for the customer registration, click the **Add** (+) icon and then repeat step 2.

**Note:** However, if you want to remove a characteristic from the customer registration, click the **Delete** (🗑️) icon corresponding to the characteristic.



**Related Topics**

For more information on...	See...
How to edit a customer registration	<a href="#">Editing the Customer Registration Details</a> on page 166

**Viewing the Details of an Account****Procedure**

To view the details of an account:

1. Search for the customer registration in the **Customer Registration** screen.
2. In the **Search Results** section, click the link in the **Customer Registration Information** column corresponding to the customer registration whose details you want to view.

The **Customer Registration** screen appears.

3. Ensure that the **Accounts** tab is selected.
4. View the details of the customer registration in the **Account Information** zone.

**Related Topics**

For more information on...	See...
How to search for a customer registration	<a href="#">Searching a Customer Registration</a> on page 117
<b>Customer Registration</b> screen	<a href="#">Customer Registration (Used for Viewing)</a> on page 154
<b>Customer Registration</b> zone	<a href="#">Customer Registration</a>
<b>Account Information</b> zone	<a href="#">Account Information</a> on page 155
<b>Policies</b> zone	<a href="#">Policies</a> on page 158
<b>Parent Policies</b> zone	<a href="#">Parent Policies</a> on page 158

**Editing the Account Details of a Person****Prerequisites**

To edit a account details of a person, you should have:

- Customer Class defined in the application
- Division defined in the application
- Invoice currencies defined in the application
- Account Category defined in the application
- Access groups defined in the application
- Bill Cycles defined in the application
- Account Identifier Types defined in the application

**Procedure**

To edit the account details of a person:

1. Search for the customer registration in the **Customer Registration** screen.
2. In the **Search Results** section, click the link in the **Customer Registration Information** column corresponding to the customer registration whose details you want to edit.

The **Customer Registration** screen appears.

3. Click the **Edit** button.

The **Customer Registration** screen appears.

4. Click the **Accounts** panel. The **Accounts** panel appears.

5. Click the **Edit** () icon in the **View / Edit** column.

The **Customer Registration - Add Account** screen appears. It contains the following fields.

Field Name	Field Description	Mandatory (Yes or No)
Customer Class	Used to indicate the customer class.	Yes (Conditional) <b>Note:</b> This field is required when you are defining account details for the customer registration.
Division	Used to indicate the division.	Yes (Conditional) <b>Note:</b> This field is required when you are defining account details for the customer registration.
Set Up Date	Used to specify the set up date.	Yes (Conditional) <b>Note:</b> This field is required when you are defining account details for the customer registration.
Invoice Currency	Used to indicate the invoice currency.	Yes (Conditional) <b>Note:</b> This field is required when you are defining account details for the customer registration.
Account Category	Used to indicate the account category.	Yes (Conditional) <b>Note:</b> This field is required when you are defining account details for the customer registration.
Access Group	Used to specify the access group. <b>Note:</b> The <b>Search</b> (  ) icon appears corresponding to the <b>Access Group</b> field. On clicking the <b>Search</b> icon, the <b>Access Group Search</b> window appears.	Yes (Conditional) <b>Note:</b> This field is required when you are defining account details for the customer registration.
Bill Cycle	Used to indicate the bill cycle.	Yes (Conditional) <b>Note:</b> This field is required when you are defining account details for the customer registration.

Field Name	Field Description	Mandatory (Yes or No)
Bill Lead Days	Used to specify the bill lead days.	Yes (Conditional) <b>Note:</b> This field is required when you are defining account details for the customer registration.
Comments	Used to specify the comments.	Yes (Conditional) <b>Note:</b> This field is required when you are defining account details for the customer registration.

6. Modify the details of the account in the **Main** panel, if required.
7. Modify the details of the account identifier in the **Account Identifiers** section of the **Main** panel, if required.
8. Modify the details of autopay in the **Autopay** panel, if required.
9. Modify the details of person in the **Persons** panel, if required.
10. Define, edit, or remove characteristics from the **Account Characteristics** panel, if required.
11. Click **Next** to continue editing an account for a person.
12. Click **Save as Draft** to save the details as a draft to add an account for a person.
13. Click **Validate and Save** to validate the details.

#### Related Topics

For more information on...	See...
How to search for a customer registration	<a href="#">Searching a Customer Registration</a> on page 117
<b>Customer Registration</b> screen	<a href="#">Customer Registration (Used for Viewing)</a> on page 154
<b>Customer Registration</b> zone	<a href="#">Customer Registration</a>
How to define a characteristic for a customer registration	<a href="#">Defining a Characteristic for Customer Registration</a> on page 144

## Copying a Customer Registration

Instead of creating a customer registration from scratch, you can create a new customer registration using an existing customer registration. This is possible through copying a customer registration. On copying a customer registration, the details including the characteristics are copied to the new customer registration. You can then edit the details, if required.

#### Prerequisites

To copy a customer registration, you should have:

- Person type (whose copy you want to create) defined in the application
- Divisions defined in the application
- Access groups defined in the application
- Name types defined in the application
- Phone types defined in the application
- Person identifier types defined in the application
- Address type code defined in the application

- Countries defined in the application
- Characteristic types defined in the application
- Parent/Child entities defined in the application
- Relationship type defined in the application

### **Procedure**

To copy a customer registration:

1. Click the **Admin** link in the **Application** toolbar.

A list appears.

2. From the **Main** menu, select **Person Information** and then click **Customer Registration**.

A sub-menu appears.

3. Click the **Search** option from the **Customer Registration** sub-menu.

The **Customer Registration** screen appears.

4. In the search result of **Search Customer Registration** zone, click the **Copy** () icon in the **Copy** column corresponding to the customer registration id whose copy you want to create.

The **Customer Registration** screen appears. It contains the following panels:

- Main
- Contact
- Person characteristics
- Hierarchy
- Accounts
- Policies
- Registration Characteristics

The **Main** panel appears. It contains the following sections:

- **Main** - Used to specify basic details about the customer registration.
- **Person Names** - Used to define the name type details about the customer registration.
- **Person Phones** - Used to define the phone type details about the customer registration.
- **Person IDs**- Used to define the identifier details about the customer registration.

The **Main** section contains the following fields:

<b>Field Name</b>	<b>Field Description</b>	<b>Mandatory (Yes or No)</b>
Person Type	Used to indicate the type of a person. <div style="border: 1px solid black; padding: 2px; margin-top: 5px;"><b>Note:</b> This field is in the read-only mode.</div>	Yes
Date of Birth	Used to indicate the date of birth.	Not applicable
Division	Used to indicate the division.	Yes
Person Since Date	Used to indicate the person since date.	Yes

Field Name	Field Description	Mandatory (Yes or No)
Customer Segment	Used to indicate the customer segment. <b>Note:</b> This field appears only when <b>Customer Registration Type</b> is <b>Banking</b> .	No
Customer Tier	Used to indicate the customer tier. <b>Note:</b> This field appears only when <b>Customer Registration Type</b> is <b>Banking</b> .	Yes
Access Group	Used to indicate the access group.  The <b>Search</b> (🔍) icon appears corresponding to the <b>Access Group</b> field. On clicking the <b>Search</b> icon, you can search for a predefined access groups.  The selected access group appears next to <b>Access Group</b> field.	Yes

5. Enter the required details in the **Main** section.
6. Define names of a person, if required.
7. Define phone details for a person, if required.
8. Define identifier details for a person, if required.
9. Define addresses of a person in the **Contact** panel, if required.
10. Define characteristics of a person in the **Person Characteristics** panel, if required.
11. Define hierarchy of a person in the **Hierarchy** panel, if required.
12. Define accounts in the **Accounts** panel, if required.
13. Define policies and plans in the **Policies & Plans** panel, if required.

**Note:** This panel appears only when the **Customer Registration Type** is **Healthcare**.

14. Define registration characteristics in the **Registration Characteristics** panel.
15. Click **Save as Draft** to save the details as a draft.
16. Click **Validate and Save** to validate and save the details.

The customer registration is created.

### **Related Topics**

For more information on...	See...
<b>Customer Registration</b> screen	<a href="#">Customer Registration (Used for Viewing)</a> on page 154
<b>Customer Registration</b> screen	<a href="#">Customer Registration (Used for Searching)</a> on page 108
<b>Search Customer Registration</b> zone	<a href="#">Search Customer Registration</a> on page 109
How to define a characteristic for a customer registration	<a href="#">Defining a Characteristic for Customer Registration</a> on page 144

## Viewing the Details of a Policy

To view the details of a policy, you should have:

- The **Customer Registration Type** is selected as **Healthcare**.

### Procedure

To view the details of a policy:

1. Search for the customer registration in the **Customer Registration** screen.
2. In the **Search Results** section, click the link in the **Customer Registration Information** column corresponding to the customer registration whose details you want to edit.

The **Customer Registration** screen appears.

3. Ensure that the **Policy** tab is selected.
4. View the details of the customer registration in the following zones:
  - Policy Information
  - Plans

### Related Topics

For more information on...	See...
How to search for a customer registration	<a href="#">Searching a Customer Registration</a> on page 117
<b>Customer Registration</b> screen	<a href="#">Customer Registration (Used for Viewing)</a> on page 154
<b>Customer Registration</b> zone	<a href="#">Customer Registration</a>
<b>Account Information</b> zone	<a href="#">Account Information</a> on page 155
<b>Policies</b> zone	<a href="#">Policies</a> on page 158
<b>Parent Policies</b> zone	<a href="#">Parent Policies</a> on page 158

## Editing the Policy Details

### Prerequisites

To edit a policy details, you should have:

- The **Customer Registration Type** should be selected as **Healthcare**.
- Template defined in the application
- Price item defined in the application

### Procedure

To edit the policy details:

1. Search for the customer registration in the **Customer Registration** screen.
2. In the **Search Results** section, click the link in the **Customer Registration Information** column corresponding to the customer registration whose details you want to edit.

The **Customer Registration** screen appears.

3. In the **Customer Registration** zone, click the **Edit** button.

The **Customer Registration** screen appears.

4. Click the **Policies** panel. It contains the following sections:

- **Policies & Plans** - Used to specify basic details about the policies and plans.
- **Parent Policies** - Used to define parent policies about the policies and plans.

The **Policies & Plans** section contains the following fields:

Field Name	Field Description	Mandatory (Yes or No)
Sequence No.	Used to specify the sequence number.	No
Template	Displays the selected template.	No
Policy Type	Displays the type of the policy.	Yes
Policy Number	Displays the policy number.	No
View / Edit	On clicking the <b>View / Edit</b> (✎) icon, the <b>Select Policy Type</b> screen appears where you can view or modify the policy and plans in customer registration.	No
Policy Plans	On clicking the <b>Add</b> (➕) icon, you can add policy type, plan number and its respective price item details.	No

5. In the **Policies & Plans** zone, click the **Edit** (✎) icon in the **View / Edit** column corresponding to the policies and plans whose details you want to edit.

The **Add / Edit Policy** screen appears. It contains the following fields:

Field Name	Field Description	Mandatory (Yes or No)
Policy Type	Indicates the type of policy.	Yes
Policy Number	Used to specify the policy number.	Yes
Description	Used to specify the description of policy.	No
Source System	Used to indicate the source system of the policy.	Yes
Start Date	Used to indicate the start date of the policy.	Yes
End Date	Used to indicate the end date of the policy.	Yes
Policy Person Role	Used to indicate the policy person role.	No

6. Modify the details of the persons in the **Persons** zone, if required.
7. Define, edit, or remove characteristics from the **Characteristics** zone, if required.
8. Click **Save as Draft** to save the details as a draft.
9. Click **Validate and Save** to validate and save the details.

#### **Related Topics**

For more information on...	See...
How to search for a customer registration	<a href="#">Searching a Customer Registration</a> on page 117
<b>Customer Registration</b> screen	<a href="#">Customer Registration (Used for Viewing)</a> on page 154
<b>Customer Registration</b> zone	<a href="#">Customer Registration</a>
How to define a characteristic for a customer registration	<a href="#">Defining a Characteristic for Customer Registration</a> on page 144

## Viewing the Details of a Policy Plan

### Prerequisites

To view the details of a policy plan, you should have:

- The **Customer Registration Type** is selected as **Healthcare**.

### Procedure

To view the details of a policy plan:

1. Search for the customer registration in the **Customer Registration** screen.
2. In the **Search Results** section, click the link in the **Customer Registration Information** column corresponding to the customer registration whose details you want to view.

The **Customer Registration** screen appears.

3. Ensure that the **Plan** tab is selected.
4. View the details of the customer registration in the **Plan Information** zone.

### Related Topics

For more information on...	See...
How to search for a customer registration	<a href="#">Searching a Customer Registration</a> on page 117
<b>Customer Registration</b> screen	<a href="#">Customer Registration (Used for Viewing)</a> on page 154
<b>Customer Registration</b> zone	<a href="#">Customer Registration</a>
<b>Account Information</b> zone	<a href="#">Account Information</a> on page 155
<b>Policies</b> zone	<a href="#">Policies</a> on page 158
<b>Parent Policies</b> zone	<a href="#">Parent Policies</a> on page 158

## Editing the Policy Plan Details

### Prerequisites

To edit a policy plan details, you should have:

- The **Customer Registration Type** should be selected as **Healthcare**.
- Runout administration fees defined in the application
- Policy person roles defined in the application

### Procedure

To edit the policy plan details:

1. Search for the customer registration in the **Customer Registration** screen.
2. In the **Search Results** section, click the link in the **Customer Registration Information** column corresponding to the customer registration whose details you want to edit.

The **Customer Registration** screen appears.

3. Click the **Edit** button in the **Customer Registration** zone.

The **Customer Registration** screen appears.

4. Click the **Policies** panel. It contains the following sections:
  - **Policies & Plans** - Used to specify basic details about the policies and plans.



- **Parent Policies** - Used to define parent policies about the policies and plans.

The **Policies & Plans** section contains the following fields:

Field Name	Field Description	Mandatory (Yes or No)
Sequence No.	Used to specify the sequence number.	No
Template	Displays the selected template.	No
Policy Type	Displays the type of the policy.	Yes
Policy Number	Displays the policy number.	No
View / Edit	On clicking the <b>View / Edit</b> (✎) icon, the <b>Select Policy Type</b> screen appears where you can view or modify the policy and plans in customer registration.	No
Policy Plans	On clicking the <b>Add</b> (📄+) icon, you can add policy type, plan number and its respective price item details.	No

5. Click **View / Edit** icon in the **View / Edit** column.

The **Add / Edit Policy** screen appears. It contains the following fields:

Field Name	Field Description	Mandatory (Yes or No)
Policy Type	Indicates the type of policy.	Yes
Policy Number	Used to specify the policy number.	Yes
Description	Used to specify the description of policy.	No
Source System	Used to indicate the name of the external system from where the policy originated.	Yes
Start Date	Used to indicate the start date of the policy.	Yes
End Date	Used to indicate the end date of the policy.	Yes
Runout End Date	Used to indicate the runout end date.	No
Runout Administration Fees	Used to indicate the runout administration fees.	No
Policy Person Role	Used to indicate the role of the policy person.	No

6. Modify the details of the persons in the **Persons** section, if required.
7. Define, edit, or remove characteristics from the **Characteristics** section, if required.
8. Click **Save as Draft** to save the details as a draft.
9. Click **Validate and Save** to validate and save the details.

### Related Topics

For more information on...	See...
How to search for a customer registration	<a href="#">Searching a Customer Registration</a> on page 117

For more information on...	See...
<b>Customer Registration</b> screen	<a href="#">Customer Registration (Used for Viewing)</a> on page 154
<b>Customer Registration</b> zone	<a href="#">Customer Registration</a>
How to define a characteristic for a customer registration	<a href="#">Defining a Characteristic for Customer Registration</a> on page 144

## Customer Registration (Used for Viewing)

The **Customer Registration** screen allows you to:

- Edit the details of a customer registration object
- Delete a customer registration object
- View the details of a customer registration object
- Submit a customer registration object for processing
- Approve or reject a customer registration object
- Request the submitter to resubmit a customer registration object for approval
- View the log of a customer registration object
- Add a log entry for a customer registration object

It consists of the following tabs:

- Main
- Account
- Policy

**Note:** This tab appears only when the **Customer Registration Type - Healthcare** business object is used while creating the customer registration object.

- Plan

**Note:** This tab appears only when the **Customer Registration Type - Healthcare** business object is used while creating the customer registration object.

- Log

For more information on...	See...
How to define a customer registration	<a href="#">Defining a Customer Registration</a> on page 119
How to edit a customer registration	<a href="#">Editing the Customer Registration Details</a> on page 166
How to copy a customer registration	<a href="#">Copying a Customer Registration</a> on page 147
How to delete a customer registration	<a href="#">Deleting a Customer Registration</a>
How to view the details of a customer registration	<a href="#">Viewing the Customer Registration Details</a> on page 118

## Customer Registration - Main

The **Main** tab displays information about the customer registration object. It contains the following zones:

- [Customer Registration](#)
- [Account Information](#) on page 155
- [Policies](#) on page 158
- [Parent Policies](#) on page 158

### Customer Registration

Oracle Revenue Management and Billing provides the automatic customer registration facility for an account, person, policy or policy plan. Initial customer setup or customer on-boarding as well as updates to the Customer information is an integral part of the Oracle Insurance Revenue Management and Billing (OIRMB) for **Healthcare** customers, be it **ASO** or Fully Insured.

In the OIRMB, the customer registration can be used to create customer and related entities by using the following methods:

- The **User Interface** for low volume data
- The **Inbound Messages** for integration with the case install systems for low to medium volume data
- The **File Upload Utility** for integration with the case install systems for high volume data

A **Customer Registration** module enables user to set up a new business in a structured manner. A user can set up:

- Parent Customer
- Bill Groups and Billing Hierarchy
- Billing Accounts and Contracts
- Policies and Plans

A complete workflow is processed through the To-do notifications sent to different **Billing Users** requesting the setup of various entities like Bill Groups, Pricing etc.

For better usability, different templates can be defined for each of the entities that are setup to enable the validations and defaulting of data.

For more information on how to setup the customer registration process, see [Prerequisites](#).

### Account Information

The **Account Information** zone displays the account details of the customer. It contains of the following sections:

- **Main** - Displays the basic information about the account. It contains the following fields:

Field Name	Field Description
Account Information	Indicates the information about the account.
Customer Class	Indicates the customer class to which account belongs.
Division	Indicates the division to which account is associated.
Set Up Date	Indicates the set up date of the account.
Invoice Currency	Indicates the invoice currency of the account.
Account Category	Indicates the category of the account.
Access Group	Indicates the access group of the account.

Field Name	Field Description
Exclude Accrual	Indicates whether the accrual is excluded.
Eligible for Repricing	Indicates whether the account is eligible for repricing.
Product	Indicates the product.
Bill Lead Days	Indicates the bill lead days.
Bill Cycle	Indicates the bill cycle.
Comments	Displays the comments entered for the account.

- **Account Identifiers** - The **Account Identifiers** section displays the account identifiers details.

Column Name	Column Description
Primary ID	Indicates whether the primary id of the account.
Account Identifier Type	Indicates the type of the account identifier.
Account Identifier	Indicates the account identifier details.

- **Account Characteristics**- The **Account Characteristics** section displays the characteristics details of the account.

Column Name	Column Description
Effective Date	Displays the date from when the characteristic is effective for the customer registration.
Characteristic Type	Indicates the characteristic type.
Characteristic Value	Displays the value for the characteristic type.

**Auto Pay Details**- The **Auto Pay Details** section displays the auto pay details of an account.

Column Name	Column Description
Defer Auto Pay Date	Displays the date from when auto pay process is to be put on deferred mode.
Rule Based Auto Pay	Indicates whether the rule based auto pay option is enabled.
Start Date	Indicates the date from when the automatic payment process is effective for an account.
End Date	Indicates the date till when the automatic payment process is effective for an account.
Percentage	Indicates the percentage of payment details.
Priority	Indicates the priority of payment.
Auto Pay Source Code	Indicates the source of funds used to make the automatic payment. For example, debit card or credit card.
Auto Pay Route Type	Indicates when and how an automatic payment request of the account is routed.
Account Number	Displays the account number.
Expires On	Indicates the date on which auto pay expires.
Name	Displays the name of the account owner.

Column Name	Column Description
Maximum Withdrawal Amount	Displays the maximum limit of the withdrawal amount.
Comments	Displays the comments entered for auto payment.

- **Account Credit Rating**

- The **Account Credit Rating** section displays the account credit rating details. It contains the following fields:

Column Name	Column Description
Collection Class	Indicates the collection class to which account belongs.
Current Credit Rating	Indicates the current credit rating.
Current Cash Only Score	Indicates the current cash only score.
Start Date	Indicates the start date.
End Date	Indicates the end date.
Affect Credit Rating By	Indicates the count by which the credit rating is affected.
Affect Cash-Only Score By	Indicates the score by which cash only affected.
Comments	Indicates the comments for account credit rating.

- **Account Persons**

- The **Account Persons** section displays the person related details.

Column Name	Column Description
Person ID	Indicates the person identification value.
Person Name	Indicates the name of the person.
Main Customer	Indicates whether the person is a main customer.
Financially Responsible	Indicates whether a person is financially responsible.
Account Relationship Type	Indicates the account relationship type.

- **Account Override Address** - The **Account Override Address** section displays the account override address. It contains the following fields:

Column Name	Column Description
Country	Indicates the country of the address of the account.
Address 1 / 2 / 3 / 4	Indicates the address details.
City	Displays the city of the address.
State	Indicates the state of the address.
Postal	Displays the postal code of the address.

- **Bill Routing Information** - The **Bill Routing Information** section displays the bill routing information of the account. It contains the following columns:

Column Name	Column Description
Receives Copy of Bill	Indicates whether to receive a copy of bill.
Bill Format	Indicates the bill format.

Column Name	Column Description
Address Source	Indicates the address source.
Number of Bill copies	Indicates the total number of bill copies.
Bill Route Type	Indicates the bill route type.
Receives Notification	Indicates whether to receive notification for the bill routing.

### Related Topics

For more information on...	See...
How to define a customer registration	<a href="#">Defining a Customer Registration</a> on page 119
How to edit a customer registration	<a href="#">Editing the Customer Registration Details</a> on page 166
How to copy a customer registration	<a href="#">Copying a Customer Registration</a> on page 147
How to delete a customer registration	<a href="#">Deleting a Customer Registration</a>
How to view the details of a customer registration	<a href="#">Viewing the Customer Registration Details</a> on page 118

### Policies

The **Policies** zone displays the policy details of the customer registration. It contains of the following fields:

Field Name	Field Description
Sequence	Indicates the sequence number.
Template	Indicates the template of the policy.
Policy Type	Displays the type of the policy.
Policy Number	Indicates the policy number.

The **View** () icon corresponding to the policy navigates you to the **Policy** tab whose details you want to view.

### Related Topics

For more information on...	See...
How to define a customer registration	<a href="#">Defining a Customer Registration</a> on page 119
How to edit a customer registration	<a href="#">Editing the Customer Registration Details</a> on page 166
How to copy a customer registration	<a href="#">Copying a Customer Registration</a> on page 147
How to delete a customer registration	<a href="#">Deleting a Customer Registration</a>
How to view the details of a customer registration	<a href="#">Viewing the Customer Registration Details</a> on page 118

### Parent Policies

The **Parent Policies** zone displays the parent policy details of the customer registration. It contains of the following fields:

Field Name	Field Description
Sequence	Indicates the sequence number.
Policy Number	Displays the policy number.
Person Information	Indicates the information of a person.
Policy ID	Displays the policy identification number.
Link/Unlink	Indicates whether policy is linked or unlinked.
Start Date	Indicates the start date of policy.
End Date	Indicates the end date of policy.
Policy Person Role	Indicates the role of the policy person.

By default, the **Parent Policies** zone does not appear in the **Customer Registration** screen. It appears only when there is an active policy created in the **Person Hierarchy** panel with either parent or child relationship based on the selected relationship type.

### **Related Topics**

For more information on...	See...
How to define a customer registration	<a href="#">Defining a Customer Registration</a> on page 119
How to edit a customer registration	<a href="#">Editing the Customer Registration Details</a> on page 166
How to copy a customer registration	<a href="#">Copying a Customer Registration</a> on page 147
How to delete a customer registration	<a href="#">Deleting a Customer Registration</a>
How to view the details of a customer registration	<a href="#">Viewing the Customer Registration Details</a> on page 118

## **Customer Registration - Account**

The **Account** tab displays information about the account. It contains the following zone:

- [Account Information](#) on page 155

### **Account Information**

The **Account Information** zone displays the account details of the customer. It contains of the following sections:

- **Main** - Displays the basic information about the account. It contains the following fields:

Field Name	Field Description
Account Information	Indicates the information about the account.
Customer Class	Indicates the customer class to which account belongs.
Division	Indicates the division to which account is associated.
Set Up Date	Indicates the set up date of the account.
Invoice Currency	Indicates the invoice currency of the account.
Account Category	Indicates the category of the account.
Access Group	Indicates the access group of the account.

Field Name	Field Description
Exclude Accrual	Indicates whether the accrual is excluded.
Eligible for Repricing	Indicates whether the account is eligible for repricing.
Product	Indicates the product.
Bill Lead Days	Indicates the bill lead days.
Bill Cycle	Indicates the bill cycle.
Comments	Displays the comments entered for the account.

- **Account Identifiers** - The **Account Identifiers** section displays the account identifiers details.

Column Name	Column Description
Primary ID	Indicates whether the primary id of the account.
Account Identifier Type	Indicates the type of the account identifier.
Account Identifier	Indicates the account identifier details.

- **Account Characteristics**- The **Account Characteristics** section displays the characteristics details of the account.

Column Name	Column Description
Effective Date	Displays the date from when the characteristic is effective for the customer registration.
Characteristic Type	Indicates the characteristic type.
Characteristic Value	Displays the value for the characteristic type.

**Auto Pay Details**- The **Auto Pay Details** section displays the auto pay details of an account.

Column Name	Column Description
Defer Auto Pay Date	Displays the date from when auto pay process is to be put on deferred mode.
Rule Based Auto Pay	Indicates whether the rule based auto pay option is enabled.
Start Date	Indicates the date from when the automatic payment process is effective for an account.
End Date	Indicates the date till when the automatic payment process is effective for an account.
Percentage	Indicates the percentage of payment details.
Priority	Indicates the priority of payment.
Auto Pay Source Code	Indicates the source of funds used to make the automatic payment. For example, debit card or credit card.
Auto Pay Route Type	Indicates when and how an automatic payment request of the account is routed.
Account Number	Displays the account number.
Expires On	Indicates the date on which auto pay expires.
Name	Displays the name of the account owner.



Column Name	Column Description
Maximum Withdrawal Amount	Displays the maximum limit of the withdrawal amount.
Comments	Displays the comments entered for auto payment.

- **Account Credit Rating**

- The **Account Credit Rating** section displays the account credit rating details. It contains the following fields:

Column Name	Column Description
Collection Class	Indicates the collection class to which account belongs.
Current Credit Rating	Indicates the current credit rating.
Current Cash Only Score	Indicates the current cash only score.
Start Date	Indicates the start date.
End Date	Indicates the end date.
Affect Credit Rating By	Indicates the count by which the credit rating is affected.
Affect Cash-Only Score By	Indicates the score by which cash only affected.
Comments	Indicates the comments for account credit rating.

- **Account Persons**

- The **Account Persons** section displays the person related details.

Column Name	Column Description
Person ID	Indicates the person identification value.
Person Name	Indicates the name of the person.
Main Customer	Indicates whether the person is a main customer.
Financially Responsible	Indicates whether a person is financially responsible.
Account Relationship Type	Indicates the account relationship type.

- **Account Override Address** - The **Account Override Address** section displays the account override address. It contains the following fields:

Column Name	Column Description
Country	Indicates the country of the address of the account.
Address 1 / 2 / 3 / 4	Indicates the address details.
City	Displays the city of the address.
State	Indicates the state of the address.
Postal	Displays the postal code of the address.

- **Bill Routing Information** - The **Bill Routing Information** section displays the bill routing information of the account. It contains the following columns:

Column Name	Column Description
Receives Copy of Bill	Indicates whether to receive a copy of bill.
Bill Format	Indicates the bill format.

Column Name	Column Description
Address Source	Indicates the address source.
Number of Bill copies	Indicates the total number of bill copies.
Bill Route Type	Indicates the bill route type.
Receives Notification	Indicates whether to receive notification for the bill routing.

### Related Topics

For more information on...	See...
How to define a customer registration	<a href="#">Defining a Customer Registration</a> on page 119
How to edit a customer registration	<a href="#">Editing the Customer Registration Details</a> on page 166
How to copy a customer registration	<a href="#">Copying a Customer Registration</a> on page 147
How to delete a customer registration	<a href="#">Deleting a Customer Registration</a>
How to view the details of a customer registration	<a href="#">Viewing the Customer Registration Details</a> on page 118

## Customer Registration - Policy

The **Policy** tab displays policy and plan information of a customer. It contains the following zones:

- [Policy Information](#) on page 162
- [Plans](#) on page 163

### Policy Information

The **Policy Information** zone displays the policy details of the customer registration. It contains of the following sections:

- **Main** - Displays the basic information about the policy. It contains the following fields:

Field Name	Field Description
Policy Type	Indicates the type of the policy.
Start Date	Indicates the start date of the policy.
Policy Number	Displays the policy number.
End Date	Indicates the end date of the policy.
Description	Displays the description of the policy.
Runout End Date	Displays the runout end date.
Runout Administration Fees	Displays the runout administration fees.
Policy Person Role	Indicates the role of the policy person who is getting registered.

- **Persons**

- The **Persons** section lists the persons associated with the policy.

Column Name	Column Description
Person ID	Indicates the person for whom the customer registration is created.
Sequence	Indicates the order in which the persons must appear in the list.
Policy Person Role	Indicates the role of the person in the policy.
Main Customer	Indicates whether the person is the main customer of the policy. <b>Note:</b> This field is in the Read-only mode.
Start Date	Indicates the date from when the policy is effective for a person.
End Date	Indicates the date till when the policy is effective for a person.

- **Characteristics**

- The **Characteristics** section displays the auto pay details of an account.

Column Name	Column Description
Effective Date	Displays the date from when the characteristic is effective for the customer registration.
Characteristic Type	Indicates the characteristic type.
Characteristic Value	Displays the value for the characteristic type.

### Related Topics

For more information on...	See...
How to define a customer registration	<a href="#">Defining a Customer Registration</a> on page 119
How to edit a customer registration	<a href="#">Editing the Customer Registration Details</a> on page 166
How to copy a customer registration	<a href="#">Copying a Customer Registration</a> on page 147
How to delete a customer registration	<a href="#">Deleting a Customer Registration</a>
How to view the details of a customer registration	<a href="#">Viewing the Customer Registration Details</a> on page 118

### **Plans**

The **Plans** zone displays the plans of a policy. It contains of the following columns:

Column Name	Column Description
Sequence	Displays the sequence number.
Template	Indicates the template selected for the customer registration. <b>Note:</b> It has a link. On clicking the link, the <b>Customer Registration Template</b> screen appears where you can view the details of the respective template.
Policy Plan Number	Displays the policy plan number.
Price Item	Displays the price item.

**Note:** You can view the policy plan details of the customer by clicking the **View** () icon corresponding to the record.

### Related Topics

For more information on...	See...
How to define a customer registration	<a href="#">Defining a Customer Registration</a> on page 119
How to edit a customer registration	<a href="#">Editing the Customer Registration Details</a> on page 166
How to copy a customer registration	<a href="#">Copying a Customer Registration</a> on page 147
How to delete a customer registration	<a href="#">Deleting a Customer Registration</a>
How to view the details of a customer registration	<a href="#">Viewing the Customer Registration Details</a> on page 118

## Customer Registration - Plan

The **Plan** tab displays additional information about the policy plan. It contains the following zone:

- [Plan Information](#) on page 164

### Plan Information

The **Plan Information** zone displays the policy plan details of the customer registration. It contains of the following sections:

- **Main** - Displays the basic information about the policy plan. It contains the following fields:

Column Name	Column Description
Plan Number	Displays the policy plan number.
Price Item	Indicates the price item.
Start Date	Indicates the start date of policy plan.
End Date	Indicates the end date of policy plan.

- **Pricing Rule Types**

- The **Pricing Rule Types** section displays the pricing rule types.

Column Name	Column Description
Pricing Rule Type	Indicates the pricing rule type.

- **Characteristics**

- The **Characteristics** section displays the auto pay details of an account.

Column Name	Column Description
Effective Date	Displays the date from when the characteristic is effective for the customer registration.
Characteristic Type	Indicates the characteristic type.
Characteristic Value	Displays the value for the characteristic type.

### Related Topics

For more information on...	See...
How to define a customer registration	<a href="#">Defining a Customer Registration</a> on page 119
How to edit a customer registration	<a href="#">Editing the Customer Registration Details</a> on page 166
How to copy a customer registration	<a href="#">Copying a Customer Registration</a> on page 147
How to delete a customer registration	<a href="#">Deleting a Customer Registration</a>
How to view the details of a customer registration	<a href="#">Viewing the Customer Registration Details</a> on page 118

## Customer Registration - Log

The **Log** tab displays information about the customer registration object. It contains the following zone:

- [Customer Registration Log](#) on page 165

### Customer Registration Log

The **Customer Registration Log** zone lists the complete trail of actions performed on the customer registration. It contains the following columns:

Column Name	Column Description
Date/Time	Displays the date and time when the action was performed on the customer registration.
Details	Displays the details of the action performed on the customer registration.
User	Indicates the user who has performed the action on the customer registration.
Log Type	Indicates the type of log.
Related Object	Indicates the object or entity which is created when the action is performed on the customer registration.  <b>Note:</b> At present, no data appears in this column. The implementation team can build the custom logic to meet the business requirements.
Status Reason	Indicates the reason why the customer registration was rejected by the approver.  <b>Note:</b> The data appears in this column only when the customer registration is in the <b>Rejected</b> status.

**Note:** You can manually add a log entry for the customer registration by clicking the **Add Log Entry** link in the upper right corner of the this zone.

### Related Topics

For more information on...	See...
How to view the log of a customer registration	<a href="#">Viewing the Log of a Customer Registration</a> on page 172
How to add a log entry for a customer registration	<a href="#">Adding a Log Entry for a Customer Registration</a> on page 173

## Editing the Customer Registration Details

### Prerequisites

To edit a customer registration, you should have:

- Person Types defined in the application
- Divisions defined in the application
- Access Groups defined in the application
- Name Types defined in the application
- Phone Types defined in the application
- Person Identifier Types defined in the application
- Address Type Codes defined in the application
- Countries defined in the application
- Characteristic Types defined in the application
- Parent/Child defined in the application
- Relationship Types defined in the application
- Customer classes defined in the application
- Invoice currencies defined in the application
- Account categories defined in the application
- Bill cycles defined in the application
- Account Identifier Types defined in the application
- Person IDs defined in the application
- Account Relationship Type defined in the application
- Bill formats defined in the application
- Address Source defined in the application
- Bill Route Types defined in the application
- Policy Types defined in the application
- Source systems defined in the application
- Policy person roles defined in the application

### Procedure

To edit a customer registration:

1. Search for the customer registration in the **Customer Registration** screen.
2. In the **Search Results** section, click the link in the **Customer Registration ID** column corresponding to the customer registration whose details you want to edit.

The **Customer Registration** screen appears.

3. Click the **Edit** button in the **Customer Registration** zone.

The **Customer Registration** screen appears. It contains the following panels:

- **Main** - Used to specify basic details about the customer registration.
- **Contact** - Used to specify contact details of the customer registration.

- **Person Characteristics**- Used to specify the characteristics details of the customer registration.
- **Hierarchy**- Used to define person to person relationship related information about customer registration.
- **Accounts**- Used to define account related information about customer registration.
- **Policies**- Used to define plans and policies related information of for the customer registration.
- **Registration Characteristics**- Used to define registration characteristics for the customer registration.

The **Main** panel appears. It contains the following sections:

- **Person Name** - Used to indicate person names for the customer registration.
- **Person Phones**- Used to indicate person phones for the customer registration.
- **Person IDs**- Used to indicate person ids for the customer registration.

The **Main** section contains the following fields:

Field Name	Field Description	Mandatory (Yes or No)
Person Type	Used to indicate the type of a person.	Yes
Date of Birth	Used to indicate the date of birth.	No
Division	Used to indicate the division to which person belongs.	No
Person Since Date	Used to indicate the person since date.	No
Customer Segment	Used to indicate the customer segment.	No
Customer Tier	Used to indicate the customer tier.	No
Access Group	Used to indicate the access group.  The <b>Search</b>  icon appears corresponding to the <b>Access Group</b> field. On clicking the <b>Search</b> icon, you can search for a predefined access groups.	No

**Note:** The **Edit** button appears only when the customer registration is in the **Draft** status.

4. Modify the details in the **Main** section, if required.
5. Modify the details in the **Person Names** section, if required.
6. Modify the details in the **Person Phones** section, if required.
7. Modify the details in the **Person IDs** section, if required.
8. Modify the details in the **Person Addresses** zone of the **Contact** panel, if required.
9. Modify the details in the **Characteristics** zone of the **Person Characteristics** panel, if required.
10. Modify the details in the **Related Person Information** zone of the **Hierarchy** panel, if required.
11. Modify the details in the **Accounts** zone of the **Accounts** panel, if required.
12. Modify the details in the **Policies & Plans** zone of the **Policies** panel, if required.

**Note:** This panel will appear only when the base of the **Customer registration Type** is **Healthcare**

13. Modify the details in the **Parent Policies** zone of the **Policies** panel, if required.
14. Define, edit, or remove characteristics from the **Characteristics** zone of the **Registration Characteristics** panel, if required.

15. Click **Save as Draft** to save the customer registration details.

The changes made to the customer registration are saved as **Draft**.

16. Click **Validate and Save** to validate and save the customer registration details.

The changes made to the customer registration are validated and saved.

### Related Topics

For more information on...	See...
How to search for a customer registration	<a href="#">Searching a Customer Registration</a> on page 117
<b>Customer Registration</b> screen	<a href="#">Customer Registration (Used for Viewing)</a> on page 154
<b>Customer Registration</b> zone	<a href="#">Customer Registration</a>
How to define a characteristic for a customer registration	<a href="#">Defining a Characteristic for Customer Registration</a> on page 144

## Submitting a Customer Registration

### Prerequisites

To submit a customer registration, you should have:

- Customer Registration Types defined in the application.
- Person Types defined in the application.

### Procedure

To submit a customer registration:

1. Search for the customer registration in the **Customer Registration** screen.
2. In the **Search Results** section, click the link in the **Customer Registration Information** column corresponding to the customer registration that you want to submit.

The **Customer Registration** screen appears.

3. Click the **Submit** button in the **Customer Registration** zone.

**Note:** The **Submit** button appears only when the customer registration is in the **Draft** status.

### Related Topics

For more information on...	See...
How to search for a customer registration	<a href="#">Searching a Customer Registration</a> on page 117
<b>Customer Registration</b> screen	<a href="#">Customer Registration (Used for Viewing)</a> on page 154
<b>Customer Registration</b> zone	<a href="#">Customer Registration</a>

## Approving a Customer Registration

You can view the number of customer registrations which are pending for an approval in the **Customer Registration** screen. The approver can review, and accordingly approve, reject, or ask the submitter to resubmit the customer registration based on the observations.

**Note:** The system will not allow you to approve, reject or resubmit a customer registration submitted by you.

### Procedure



To approve a customer registration:

1. Do either of the following:

If you want to...	Then...
Approve a customer registration through the <b>Customer Registration</b> screen	<ol style="list-style-type: none"> <li>1. Search for the customer registration in the <b>Customer Registration</b> screen.</li> <li>2. In the <b>Search Results</b> section, click the link in the <b>Customer Registration ID</b> column corresponding to the customer registration which you want to review.</li> </ol>
Approve a customer registration from the <b>To Do List</b> screen	<ol style="list-style-type: none"> <li>1. Click the <b>Menu</b> link in the <b>Application</b> toolbar. A list appears.</li> <li>2. From the <b>Main</b> menu, select <b>To Do</b> and then click <b>To Do List</b>. The <b>To Do Type for User Search</b> window appears.</li> <li>3. Enter <b>C1-CustomerRegistration</b> in the <b>To Do Type</b> field.</li> <li>4. Click the <b>Search</b> button corresponding to the <b>To Do Type</b> field.</li> <li>5. Click <b>Search</b>. The <b>To Do Type Search</b> screen appears.</li> </ol>

The **Customer Registration** screen appears.

2. Review the details in the **Customer Registration** screen.
3. If the information in the customer registration is accurate, then click the **Approve** button in the **Customer Registration** zone.

**Note:** The **Approve** button appears only when:

- The status of customer registration is in the **Approval In Progress**.
- A user with the approval To Do role is reviewing the customer registration.

### Related Topics

For more information on...	See...
How to search for a customer registration	<a href="#">Searching a Customer Registration</a> on page 117
<b>Customer Registration</b> screen	<a href="#">Customer Registration (Used for Viewing)</a> on page 154
<b>Customer Registration</b> zone	<a href="#">Customer Registration</a>

## Rejecting a Customer Registration

### Prerequisites

To reject a customer registration, you should have:

- Reasons defined for the **Rejected** status of the **C1-CustomerRegistration** business object in the **Status Reason** screen

**Note:** The system will not allow you to approve, reject or resubmit a customer registration submitted by you.

### **Procedure**

To reject a customer registration:

1. Do either of the following:

If you want to...	Then...
Reject a customer registration through the <b>Customer Registration</b> screen	<ol style="list-style-type: none"> <li>1. Search for the customer registration in the <b>Customer Registration</b> screen.</li> <li>2. In the <b>Search Results</b> section, click the link in the <b>Customer Registration Information</b> column corresponding to the customer registration which you want to review.</li> </ol>
Reject a customer registration from the <b>To Do List</b> screen	<ol style="list-style-type: none"> <li>1. Click the <b>Menu</b> link in the <b>Application</b> toolbar. A list appears.</li> <li>2. From the <b>Main</b> menu, select <b>To Do</b> and then click <b>To Do List</b>. The <b>To Do Type for User Search</b> window appears.</li> <li>3. Enter <b>C1-CustomerRegistration</b> in the <b>To Do Type</b> field.</li> <li>4. Click the <b>Search</b> button corresponding to the <b>To Do Type</b> field. The <b>To Do List</b> screen appears.</li> <li>5. Select the <b>Open</b> option from the <b>Filter by</b> list to view all unassigned To Dos.</li> <li>6. Click the link in the <b>Message</b> column corresponding to the To Do of the customer registration that you want to review.</li> </ol>

The **Customer Registration** screen appears.

2. Review the details in the **Customer Registration** screen.
3. If the information in the customer registration is incorrect, then click the **Reject** button in the **Customer Registration** zone.

The **Reject Customer Registration** window appears. It contains following fields:

Field Name	Field Description	Mandatory (Yes or No)
Status Reason	Used to indicate the reason why you want to reject the customer registration.  <b>Note:</b> The list includes only those reasons which are defined for the <b>Rejected</b> status of the <b>C1-CustomerRegistration</b> business object in the <b>Status Reason</b> screen.	Yes
Comments	Used to specify additional information while rejecting the customer registration.	No

**Note:** The **Reject** button appears only when:

- The customer registration is in the **Approval In Progress** status.
- A user with the approval To Do role is reviewing the customer registration.

4. Select the reason for rejection of the customer registration from the **Status Reason** field.
5. Click **Save**.

The status of the customer registration is changed to **Rejected**.

#### Related Topics

For more information on...	See...
How to search for a customer registration	<a href="#">Searching a Customer Registration</a> on page 117
<b>Customer Registration</b> screen	<a href="#">Customer Registration (Used for Viewing)</a> on page 154
<b>Customer Registration</b> zone	<a href="#">Customer Registration</a>

## Requesting to Resubmit a Customer Registration for Approval

### Procedure

To initiate a resubmission request for a customer registration:

1. Do either of the following:

If you want to...	Then...
Request the submitter to resubmit a customer registration through the <b>Customer Registration</b> screen	<ol style="list-style-type: none"> <li>1. Search for the customer registration in the <b>Customer Registration</b> screen.</li> <li>2. In the <b>Search Results</b> section, click the link in the <b>Customer Registration ID</b> column corresponding to the customer registration which you want to review.</li> </ol>
Request the submitter to resubmit a customer registration from the <b>To Do List</b> screen	<ol style="list-style-type: none"> <li>1. Click the <b>Menu</b> link in the <b>Application</b> toolbar. A list appears.</li> <li>2. From the <b>Main</b> menu, select <b>To Do</b> and then click <b>To Do List</b>.</li> </ol>

If you want to...	Then...
	<p>The <b>To Do Type for User Search</b> window appears.</p> <ol style="list-style-type: none"> <li>Enter <b>C1-CustomerRegistration</b> in the <b>To Do Type</b> field.</li> <li>Click the <b>Search</b> button corresponding to the <b>To Do Type</b> field.</li> </ol> <p>The <b>To Do List</b> screen appears.</p> <ol style="list-style-type: none"> <li>Select the <b>Open</b> option from the <b>Filter by</b> list to view all unassigned To Dos.</li> <li>Click the link in the <b>Message</b> column corresponding to the To Do of the customer registration that you want to review.</li> </ol>

The **Customer Registration** screen appears.

- Review the details in the **Customer Registration** screen.
- If the information in the customer registration is incomplete and you want the submitter to make the required changes and resubmit, click the **Re Submit** button in the **Customer Registration** zone.

The **Resubmit Customer Registration** window appears. It contains the following field:

Field Name	Field Description	Mandatory (Yes or No)
Comments	Used to specify the changes which the submitter should make in the customer registration before resubmitting it for approval.	Yes

**Note:** The **Re Submit** button appears only when:

- The customer registration is in the **Approval In Progress** status.
- A user with the approval To Do role is reviewing the customer registration.

- Enter the comments in the respective field and then click **Save**.

A To Do is created using the submitter To Do type and assigned to all users with a submitter To Do role specified in the customer registration type. In addition, the status of the customer registration is changed to **Draft**.

### **Related Topics**

For more information on...	See...
How to search for a customer registration	<a href="#">Searching a Customer Registration</a> on page 117
<b>Customer Registration</b> screen	<a href="#">Customer Registration (Used for Viewing)</a> on page 154
<b>Customer Registration</b> zone	<a href="#">Customer Registration</a>

## **Viewing the Log of a Customer Registration**

### **Procedure**

To view the log of a customer registration:

1. Search for the customer registration in the **Customer Registration** screen.
2. In the **Search Results** section, click the link in the **Customer Registration Information** column corresponding to the customer registration whose log you want to view.

The **Customer Registration** screen appears.

3. Click the **Log** tab.

The **Log** tab appears.

4. View the complete trail of actions performed on the customer registration in the **Customer Registration Log** zone.

### Related Topics

For more information on...	See...
How to search for a customer registration	<a href="#">Searching a Customer Registration</a> on page 117
How to add a log entry for a customer registration	<a href="#">Adding a Log Entry for a Customer Registration</a> on page 173
<b>Customer Registration</b> screen	<a href="#">Customer Registration (Used for Viewing)</a> on page 154
<b>Customer Registration Log</b> zone	<a href="#">Customer Registration Log</a> on page 165

## Adding a Log Entry for a Customer Registration

### Procedure

To add a log entry for a customer registration:

1. Search for the customer registration in the **Customer Registration** screen.
2. In the **Search Results** section, click the link in the **Customer Registration ID** column corresponding to the customer registration whose log you want to edit.

The **Customer Registration** screen appears.

3. Click the **Log** tab.

The **Log** tab appears.

4. Click the **Add Log Entry** link in the upper right corner of the **Customer Registration Log** zone.

The **Add Request Log** window appears. It contains the following fields:

Field Name	Field Description	Mandatory (Yes or No)
Request Information	Displays information about the customer registration.	Not applicable
Log Details	Used to specify additional comments on the customer registration.	Yes

5. Enter the comments in the **Log Details** field.
6. Click **Save**.

The log entry is added in the **Customer Registration Log** zone.

### Related Topics

For more information on...	See...
How to search for a customer registration	<a href="#">Searching a Customer Registration</a> on page 117
<b>Customer Registration</b> screen	<a href="#">Customer Registration (Used for Viewing)</a> on page 154

For more information on...	See...
<b>Customer Registration Log zone</b>	<a href="#">Customer Registration Log</a> on page 165

---

# Chapter 4

---

## Customer 360° View

---

### Topics:

- [Prerequisites](#)
- [Customer 360° View](#)
- [Customer 360° Information](#)
- [Bill Information](#)

Oracle Revenue Management and Billing provides a new screen named **Customer 360° View** which enables you to quickly view in-depth information about the person. This screen can be used to view the 360° information of a person who is associated with the fully insured group or self-funded policy. It provides the following information:

- Basic details, characteristics, child persons, person hierarchy, person billing hierarchy, and the customer contacts of the person.
- Customer registration objects through which the bill groups are created for a parent customer.
- List of accounts to which the parent customer and its bill groups are associated.
- Basic details, characteristics, administrative contracts, automatic payment options, billing and adjustment summary, financial and collections summary, and unpaid bills of the person's account.
- Consolidated view of the transactions (such as, billing, payment, payment cancellation, adjustment, adjustment cancellation, automatic payments sent to the auto clearing house for review, refund, write off, excess credit, and reconciliation) which are carried out for the person's account.
- List of policies to which the parent customer or bill group is associated. The system lists those policies where the policy category is set to **Self-Funded** and **Fully Insured Group**.
- Basic details, related persons, and policy plans in the person's policy.
- Basic and in-depth details of the pricing rules which are defined for a parent customer who is associated with the self-funded policy.
- Basic and in-depth details of the pricing rules which are defined for a self-funded policy of a bill group.
- Basic and in-depth details of the pricing rules which are defined for a fully-insured policy plan.
- Basic details of the pricing groups defined for a bill group who is associated with the self-funded policy.
- Basic details of the approval transactions which are created while defining, editing, and deleting the pricing rules of the parent customer and bill group.
- Basic details of the bill, adjustments which are swept onto the bill, activities (such as, payment, offset, refund, write off, or transfer) through which the bill is settled, high-level summary and details of the bill segments which are included in the bill, active hold requests due to which the bill is kept on hold, offset requests through which the bill is offset

against another bill, and refund and write off requests through which the bill or its bill segment is either refunded or written off.

In other words, this feature allows you to drill-down to see or act on all current and historical revenue management and billing details. This allows you to professionally and efficiently handle customer inquiries and complaints at the first point of contact, raising your customer service from previously unattainable levels and reducing the associated time and cost.



## Prerequisites

---

To setup the Customer 360° View feature, you need do the following:

- Define the required divisions, customer classes, person types, person identifier types, account identifier types, policy types, and policy person roles in the system
- Define values for the **C1-SourceSystemLookup** extendable lookup
- Define the required characteristic types where the characteristic entity is set to **Person**
- Define the required characteristic types where the characteristic entity is set to **Account**
- Define the required characteristic types where the characteristic entity is set to **Policy**
- Define values for the **Administrative Contract Type** and **On Account Contract Type** option types in the **C1\_CMO** feature configuration

**Note:** This prerequisite is not required when you are viewing the 360° information of a person who is associated with the self-funded policy.

- Define values for **Premium Amount SQI** and **Coverage End Date SQI** option types in the **C1-BILLADJSQ** feature configuration

**Note:** This prerequisite is not required when you are viewing the 360° information of a person who is associated with the self-funded policy.

- Define value for the **Person Relationship Type** option type in the **C1-ASOBLNG** feature configuration

### Related Topics

For more information on...	See...
How to setup the <b>C1_CMO</b> feature configuration	<a href="#">Setting the C1_CMO Feature Configuration</a> on page 2906
How to setup the <b>C1-ASOBLNG</b> feature configuration	<a href="#">Setting the C1-ASOBLNG Feature Configuration</a> on page 2889
How to setup the <b>C1-BILLADJSQ</b> feature configuration	<a href="#">Setting the C1-BILLADJSQ Feature Configuration</a> on page 2904

## Customer 360° View

---

The **Customer 360° View** screen allows you to search for a person, its accounts, and policies using various search criteria. It contains the following zone:

- [360° Search](#) on page 177

### 360° Search

The **360° Search** zone allows you to search for a person, account, and policy using various search criteria. It contains the following two sections:

- **Search Criteria** – The **Search Criteria** section contains the following fields:

Field Name	Field Description	Mandatory (Yes or No)
Search By	<p>Used to indicate whether you want to search for a person, account, or policy. The valid values are:</p> <ul style="list-style-type: none"> <li>• Policy</li> <li>• Person</li> <li>• Account</li> </ul> <p><b>Note:</b> By default, the <b>Policy</b> option is selected.</p>	Yes
Policy Type	<p>Used to search policies which are created using a particular policy type.</p> <p><b>Note:</b> This field appears when the <b>Policy</b> option is selected from the <b>Search By</b> list.</p>	No
Source System	<p>Used to search policies which were created in a particular external system.</p> <p><b>Note:</b> This field appears when the <b>Policy</b> option is selected from the <b>Search By</b> list.</p>	No
Policy Number	<p>Used to search a policy with a particular policy number.</p> <p><b>Note:</b> This field appears when the <b>Policy</b> option is selected from the <b>Search By</b> list.</p>	No
Policy ID	<p>Used to search a particular policy.</p> <p><b>Note:</b> This field appears when the <b>Policy</b> option is selected from the <b>Search By</b> list.</p>	No
Policy Person Role	<p>Used to search policies where a person is assigned a particular person role.</p> <p><b>Note:</b> This field appears when the <b>Policy</b> option is selected from the <b>Search By</b> list.</p>	No

Field Name	Field Description	Mandatory (Yes or No)
Person Name	<p>Used to search a particular person using its primary name. If you specify the person name while searching for an account, the system searches all accounts where the person is the main customer. However, if you specify the person name while searching for a policy, the system searches all policies where the person is the main customer.</p> <p><b>Note:</b> This field appears when:</p> <ul style="list-style-type: none"> <li>• The <b>Policy</b> or <b>Person</b> option is selected from the <b>Search By</b> list.</li> <li>• The <b>Account</b> option is selected from the <b>Search By</b> list and the <b>Advanced Search</b> link available in the right side of the <b>360° Search</b> zone is clicked.</li> </ul>	<p>Yes (Conditional)</p> <p><b>Note:</b> This field is required when you are searching for a policy using the policy person role.</p>
Status	<p>Used to search policies with a particular status. The valid values are:</p> <ul style="list-style-type: none"> <li>• In Force/Active</li> <li>• Canceled</li> <li>• Pending Cancellation</li> <li>• Pending</li> <li>• Pending Reinstatement</li> <li>• Pending Termination</li> <li>• Pending Termination Overridden</li> <li>• Post Runout</li> <li>• Reinstated</li> <li>• Runout</li> <li>• Terminated</li> </ul> <p><b>Note:</b> This field appears when the <b>Policy</b> option is selected from the <b>Search By</b> list.</p>	No
Start Date	<p>Used to search policies which are effective from a particular date.</p> <p><b>Note:</b> This field appears when the <b>Policy</b> option is selected from the <b>Search By</b> list and the <b>Advanced Search</b> link available in the right side of the <b>360° Search</b> zone is clicked.</p>	No
End Date	<p>Used to search policies which are effective till a particular date.</p> <p><b>Note:</b> This field appears when the <b>Policy</b> option is selected from the <b>Search By</b> list and the <b>Advanced Search</b> link available in the right side of the <b>360° Search</b> zone is clicked.</p>	No

Field Name	Field Description	Mandatory (Yes or No)
Characteristic Type	Used to search persons, accounts, or policies with a particular type of characteristic.  <b>Note:</b> This field appears when the <b>Advanced Search</b> link available in the right side of the <b>360° Search</b> zone is clicked.	No
Characteristic Value	Used to search persons, accounts, or policies with a particular characteristic.  <b>Note:</b> This field appears when you are searching for a person, account, or policy using the characteristic type. On specifying the value for a predefined characteristic type, the description of the characteristic value appears corresponding to the <b>Characteristic Value</b> field.	Yes (Conditional)  <b>Note:</b> If you specify the characteristic type as a search criteria, you have to enter the characteristics value.
Division	Used to search persons or accounts which belong to a particular division.  <b>Note:</b> This field appears when the <b>Person</b> or <b>Account</b> option is selected from the <b>Search By</b> list.	No
Customer Class	Used to search accounts or persons' whose accounts belong to a particular customer class.  <b>Note:</b> This field appears when the <b>Person</b> or <b>Account</b> option is selected from the <b>Search By</b> list.	No
Person ID	Used to search a particular person.  <b>Note:</b> This field appears when the <b>Person</b> option is selected from the <b>Search By</b> list.	No
Person Identifier Type	Used to indicate the person identifier type based on which you want to search for a person.  <b>Note:</b> This field appears when the <b>Person</b> option is selected from the <b>Search By</b> list.	Yes (Conditional)  <b>Note:</b> If you specify the person identifier as a search criteria, you have to select the person identifier type.
Person Identifier	Used to search a person with a particular identifier.  <b>Note:</b> This field appears when the <b>Person</b> option is selected from the <b>Search By</b> list.	Yes (Conditional)  <b>Note:</b> If you specify the person identifier type as a search criteria, you have to enter the person identifier.

Field Name	Field Description	Mandatory (Yes or No)
Person Type	<p>Used to search persons of a particular type. The valid values are:</p> <ul style="list-style-type: none"> <li>• Business</li> <li>• Bill Group</li> <li>• Group</li> <li>• Broker</li> <li>• Person</li> <li>• Parent Customer</li> </ul> <p><b>Note:</b> This field appears when the <b>Person</b> option is selected from the <b>Search By</b> list and the <b>Advanced Search</b> link available in the right side of the <b>360° Search</b> zone is clicked.</p>	No
Address	<p>Used to search persons with a particular address or accounts' whose main customer has a particular address.</p> <p><b>Note:</b> This field appears when the <b>Person</b> or <b>Account</b> option is selected from the <b>Search By</b> list and the <b>Advanced Search</b> link available in the right side of the <b>360° Search</b> zone is clicked.</p>	No
City	<p>Used to search persons who belong to a particular city or accounts' whose main customer belongs to a particular city.</p> <p><b>Note:</b> This field appears when the <b>Person</b> or <b>Account</b> option is selected from the <b>Search By</b> list and the <b>Advanced Search</b> link available in the right side of the <b>360° Search</b> zone is clicked.</p>	No
Phone Number	<p>Used to search a person with a particular phone number or accounts' whose main customer has a particular phone number.</p> <p><b>Note:</b> This field appears when the <b>Person</b> or <b>Account</b> option is selected from the <b>Search By</b> list and the <b>Advanced Search</b> link available in the right side of the <b>360° Search</b> zone is clicked.</p>	No
Account ID	<p>Used to search a particular account.</p> <p><b>Note:</b> This field appears when the <b>Account</b> option is selected from the <b>Search By</b> list.</p>	No

Field Name	Field Description	Mandatory (Yes or No)
Account Identifier Type	Used to indicate the account identifier type based on which you want to search for an account.  <b>Note:</b> This field appears when the <b>Account</b> option is selected from the <b>Search By</b> list.	Yes (Conditional)  <b>Note:</b> If you specify the account identifier as a search criteria, you have to select the account identifier type.
Account Identifier	Used to search an account with a particular identifier.  <b>Note:</b> This field appears when the <b>Account</b> option is selected from the <b>Search By</b> list.	Yes (Conditional)  <b>Note:</b> If you specify the account identifier type as a search criteria, you have to enter the account identifier.

**Note:**

You must specify at least one search criterion while searching for a person, account, or policy. One more search criterion is required when you are searching for a person or account using the division and/or customer class. Similarly, one more search criterion is required when you are searching for a policy using the policy type and/or source system.

If you have specified any other search criterion along with the person ID, account ID, or policy ID, the system ignores the additional search criterion and searches using the person ID, account ID, or policy ID, respectively.

- **Search Results** – On clicking the **Search** button, the search results appear based on the specified search criteria. The **Search Results** section contains the following columns:

Column Name	Column Description
Policy Information	Displays information about the policy.  <b>Note:</b> It has a link. On clicking the link, the <b>Policy</b> screen appears where you can view the details of the respective policy. This column appears when the <b>Policy</b> option is selected from the <b>Search By</b> list.
Main Customer	Indicates the main customer of the policy or account.  <b>Note:</b> This column appears when the <b>Policy</b> or <b>Account</b> option is selected from the <b>Search By</b> list.
Source System	Displays the name of the external system in which the policy was created.  <b>Note:</b> This column appears when the <b>Policy</b> option is selected from the <b>Search By</b> list.

Column Name	Column Description
Policy Number	<p>Displays the policy number.</p> <p><b>Note:</b> This column appears when the <b>Policy</b> option is selected from the <b>Search By</b> list.</p>
Start Date	<p>Displays the date from when the policy is effective.</p> <p><b>Note:</b> This column appears when the <b>Policy</b> option is selected from the <b>Search By</b> list.</p>
End Date	<p>Displays the date till when the policy is effective.</p> <p><b>Note:</b> This column appears when the <b>Policy</b> option is selected from the <b>Search By</b> list.</p>
Status	<p>Indicates the status of the policy. The valid values are:</p> <ul style="list-style-type: none"> <li>• In Force/Active</li> <li>• Canceled</li> <li>• Pending Cancellation</li> <li>• Pending</li> <li>• Pending Reinstatement</li> <li>• Pending Termination</li> <li>• Pending Termination Overridden</li> <li>• Post Runout</li> <li>• Reinstated</li> <li>• Runout</li> <li>• Terminated</li> </ul> <p><b>Note:</b> This column appears when the <b>Policy</b> option is selected from the <b>Search By</b> list.</p>
Person Information	<p>Displays information about the person. In addition, this column has a context menu which helps in navigating to other screens in the application.</p> <p><b>Note:</b> It has a link. On clicking the link, the <b>Person</b> screen appears where you can view the details of the respective person. This column appears when the <b>Person</b> option is selected from the <b>Search By</b> list.</p>
Person Name	<p>Displays the name of the person.</p> <p><b>Note:</b> This column appears when the <b>Person</b> option is selected from the <b>Search By</b> list.</p>

Column Name	Column Description
Person Type	<p>Indicates the type of the person. The valid values are:</p> <ul style="list-style-type: none"> <li>• Business</li> <li>• Bill Group</li> <li>• Group</li> <li>• Broker</li> <li>• Person</li> <li>• Parent Customer</li> </ul> <p><b>Note:</b> This column appears when the <b>Person</b> option is selected from the <b>Search By</b> list.</p>
Primary Person Identifier Type	<p>Indicates the primary identifier type associated with the person.</p> <p><b>Note:</b> This column appears when the <b>Person</b> option is selected from the <b>Search By</b> list.</p>
Primary Person Identifier	<p>Displays the primary person identifier.</p> <p><b>Note:</b> This column appears when the <b>Person</b> option is selected from the <b>Search By</b> list.</p>
Account Information	<p>Displays information about the account. In addition, this column has a context menu which helps in navigating to other screens in the application.</p> <p><b>Note:</b> It has a link. On clicking the link, the <b>Account</b> screen appears where you can view the details of the respective account. This column appears when the <b>Account</b> option is selected from the <b>Search By</b> list.</p>
Division	<p>Indicates the division to which the account belongs.</p> <p><b>Note:</b> This column appears when the <b>Account</b> option is selected from the <b>Search By</b> list.</p>
Customer Class	<p>Indicates the customer class to which the account belongs.</p> <p><b>Note:</b> This column appears when the <b>Account</b> option is selected from the <b>Search By</b> list.</p>
Primary Account Identifier Type	<p>Indicates the primary identifier type associated with the account.</p> <p><b>Note:</b> This column appears when the <b>Account</b> option is selected from the <b>Search By</b> list.</p>
Primary Account Identifier	<p>Displays the primary account identifier.</p> <p><b>Note:</b> This column appears when the <b>Account</b> option is selected from the <b>Search By</b> list.</p>



Column Name	Column Description
Current Balance	Displays the total amount of funds in the account.  <b>Note:</b> This column appears when the <b>Account</b> option is selected from the <b>Search By</b> list.

**Note:**

You can view the 360° information of the person, account, or policy by clicking the **View**  icon corresponding to the record in the **Search Results** section.

Pagination is used to display limited number of records in the **Search Results** section. You can use the navigation links, such as **Previous** and **Next** to navigate between pages.

**Related Topics**

For more information on...	See...
How to search for a person	<a href="#">Searching for a Person</a> on page 185
How to search for an account	<a href="#">Searching for an Account</a> on page 186
How to search for a policy	<a href="#">Searching for a Policy</a> on page 187
How to view the 360° information of a person	<a href="#">Viewing the 360° Information of a Person</a> on page 188
How to view the 360° information of an account	<a href="#">Viewing the 360° Information of an Account</a> on page 190
How to view the 360° information of a policy	<a href="#">Viewing the 360° Information of a Policy</a> on page 191

**Searching for a Person****Prerequisites**

To search for a person, you should have:

- Divisions, customer classes, person types, and person identifier types defined in the application
- Characteristic types defined in the application (where the characteristic entity is set to **Person**)

**Procedure**

To search for a person:

1. Click the **Menu** link in the **Application** toolbar.  
A list appears.
2. From the **Main** menu, click **Customer 360° View**.  
The **Customer 360° View** screen appears.
3. Select the **Person** option from the **Search By** list to indicate that you want to search for a person.
4. Enter the required search criteria in the **360° Search** zone.

**Note:**

You must specify at least one search criterion while searching for a person. One more search criterion is required when you are searching for a person using the division and/or customer class.

The criteria are grouped as indicated by line separators between the criteria. Each group is independent from the other, and only one group is used at a time for searching. If you enter criteria in more than one group, the criteria from the former group is used for searching. For example, if you enter the person name (in the second criteria group) and person identifier (in the fourth criteria group), the system searches using the person name instead of the person identifier.

You must specify division and/or customer class when you are searching for a person using the city.

You must specify division, customer class, or any other criteria in the second group when you are searching for a person using the person type.

If you have specified any other search criterion along with the person ID, the system ignores the additional search criterion and searches for the person using the person ID.

ORMB search engine supports wildcard search, where you can substitute the percentage (%) symbol as a stand in for any word or letter in a search criteria. The ‘%’ wildcard character is suffixed automatically at the end of the partial search criteria. Therefore, you may or may not specify the wildcard character at the end of the partial search criteria. However, you have to prefix the wildcard character manually wherever required.

The **Advanced Search** link appears in the right side of the **360° Search** zone. On clicking the **Advanced Search** link, additional fields appear in the zone which help you to refine the search.

If you select a predefined characteristic type, the **Search**  icon appears corresponding to the **Characteristic Value** field. On clicking the **Search** icon, you can search for a predefined characteristic value.

#### 5. Click **Search**.

A list of persons that meet the search criteria appears in the **Search Results** section.

#### Related Topics

For more information on...	See...
<b>Customer 360° View</b> screen	<a href="#">Customer 360° View</a> on page 177
<b>360° Search</b> zone	<a href="#">360° Search</a> on page 177

## Searching for an Account

### Prerequisites

To search for an account, you should have:

- Divisions, customer classes, and account identifier types defined in the application
- Characteristic types defined in the application (where the characteristic entity is set to **Account**)

### Procedure

To search for an account:

1. Click the **Menu** link in the **Application** toolbar.  
A list appears.
2. From the **Main** menu, click **Customer 360° View**.  
The **Customer 360° View** screen appears.
3. Select the **Account** option from the **Search By** list to indicate that you want to search for an account.

- Enter the required search criteria in the **360° Search** zone.

**Note:**

You must specify at least one search criterion while searching for an account. One more search criterion is required when you are searching for an account using the division and/or customer class.

The criteria are grouped as indicated by line separators between the criteria. Each group is independent from the other, and only one group is used at a time for searching. If you enter criteria in more than one group, the criteria from the former group is used for searching. For example, if you enter the person name (in the fourth criteria group) and account identifier (in the third criteria group), the system searches using the account identifier instead of the person name.

You must specify division and/or customer class when you are searching for an account using the city.

If you have specified any other search criterion along with the account ID, the system ignores the additional search criterion and searches for the account using the account ID.

ORMB search engine supports wildcard search, where you can substitute the percentage (%) symbol as a stand in for any word or letter in a search criteria. The '%' wildcard character is suffixed automatically at the end of the partial search criteria. Therefore, you may or may not specify the wildcard character at the end of the partial search criteria. However, you have to prefix the wildcard character manually wherever required.

The **Advanced Search** link appears in the right side of the **360° Search** zone. On clicking the **Advanced Search** link, additional fields appear in the zone which help you to refine the search.

If you select a predefined characteristic type, the **Search**  icon appears corresponding to the **Characteristic Value** field. On clicking the **Search** icon, you can search for a predefined characteristic value.

- Click **Search**.

A list of accounts that meet the search criteria appears in the **Search Results** section.

**Related Topics**

For more information on...	See...
Customer 360° View screen	<a href="#">Customer 360° View</a> on page 177
360° Search zone	<a href="#">360° Search</a> on page 177

**Searching for a Policy****Prerequisites**

To search for a policy, you should have:

- Policy types and policy person roles defined in the application
- Values defined for the **C1-SourceSystemLookup** extendable lookup
- Characteristic types defined in the application (where the characteristic entity is set to **Policy**)

**Procedure**

To search for a policy:

- Click the **Menu** link in the **Application** toolbar.  
A list appears.
- From the **Main** menu, click **Customer 360° View**.  
The **Customer 360° View** screen appears.
- Select the **Policy** option from the **Search By** list to indicate that you want to search for a policy.

4. Enter the required search criteria in the **360° Search** zone.

**Note:**

You must specify at least one search criterion while searching for a policy. One more search criterion is required when you are searching for a policy using the policy type and/or source system.

If you have specified any other search criterion along with the policy ID, the system ignores the additional search criterion and searches for the policy using the policy ID.

You must specify the person name when you are searching for a policy using the policy person role.

ORMB search engine supports wildcard search, where you can substitute the percentage (%) symbol as a stand in for any word or letter in a search criteria. The '%' wildcard character is suffixed automatically at the end of the partial search criteria. Therefore, you may or may not specify the wildcard character at the end of the partial search criteria. However, you have to prefix the wildcard character manually wherever required.

The **Advanced Search** link appears in the right side of the **360° Search** zone. On clicking the **Advanced Search** link, additional fields appear in the zone which help you to refine the search.

If you select a predefined characteristic type, the **Search** (🔍) icon appears corresponding to the **Characteristic Value** field. On clicking the **Search** icon, you can search for a predefined characteristic value.

5. Click **Search**.

A list of policies that meet the search criteria appears in the **Search Results** section.

**Related Topics**

For more information on...	See...
Customer 360° View screen	<a href="#">Customer 360° View</a> on page 177
360° Search zone	<a href="#">360° Search</a> on page 177

**Viewing the 360° Information of a Person****Prerequisites**

To view the 360° information of a person, you should have:

- Value defined for the **Person Relationship Type** option type in the **C1-ASOBLLNG** feature configuration

**Procedure**

To view the 360° information of a person:

1. Search for the person in the **Customer 360° View** screen.
2. In the **Search Results** section, click the **View** (👁) icon corresponding to the person whose details you want to view.

The **Person** tab appears in the **Customer 360° Information** screen. It contains the following zones:

- [Person Information](#) on page 202
- [Person Characteristics](#) on page 203
- [Child Persons](#) on page 204
- [Person Hierarchy](#) on page 204

**Note:** The **Person Hierarchy** zone does not appear when you are viewing the 360° information of a person whose person type is set to **Parent Customer**.

- [Person Billing Hierarchy](#) on page 205

**Note:** The **Person Billing Hierarchy** zone appears when you are viewing the 360° information of a person whose person type is set to **Parent Customer**.

- [Bill Group Derivation and Pricing Parameters](#) on page 208

**Note:** The **Bill Group Derivation and Pricing Parameters** zone appears when you are viewing the 360° information of a person whose person type is set to **Parent Customer**.

- [Bill Group Sorting](#) on page 210

**Note:** The **Bill Group Sorting** zone appears when you are viewing the 360° information of a person whose person type is set to **Parent Customer**.

- [Customer Contacts](#) on page 211
- [Bill Groups Created Via Customer Registration](#) on page 212

**Note:** The **Bill Groups Created Via Customer Registration** zone appears when you are viewing the 360° information of a person whose person type is set to **Parent Customer**.

3. View the basic details of the person in the **Person Information** zone.
4. View the characteristics defined for the person in the **Person Characteristics** zone.
5. View the child persons included in the person's hierarchy in the **Child Persons** zone.
6. View the accounts and policies where the person is the main customer and memberships where the person is the main subscriber in the **Person Hierarchy** zone.
7. View the parent customer's accounts and policies and its bill groups' accounts and policies in the **Person Billing Hierarchy** zone.
8. View the derivation and pricing parameters defined for the bill group and sort ID combinations in the **Bill Group Derivation and Pricing Parameters** zone.
9. View the sort IDs defined for the bill groups in the **Bill Group Sorting** zone.
10. View how and when the person was contacted in the **Customer Contacts** zone.
11. View the customer registration objects through which the bill groups are created for the parent customer in the **Bill Groups Created Via Customer Registration** zone.
12. If required, you can view the details of the account to which the person is associated in the **Account** tab.

**Note:**

If you are viewing the 360° information of a parent customer, the following zones appear in the **Account** tab when you click the **Broadcast**  icon corresponding to the account in the **Account List** zone:

- Account Information
- Auto Pay Details
- Account Financial and Collections Summary
- Account Characteristics
- Open Bills
- Billed Vs Paid
- Timeline

13. If required, you can view the details of the policy to which the person is associated in the **Policy** tab.

14. If required, you can view the pricing information of a parent customer or bill group in the **Pricing** tab.

### Related Topics

For more information on...	See...
How to search for a person	<a href="#">Searching for a Person</a> on page 185
<b>Customer 360° Information</b> screen	<a href="#">Customer 360° Information</a> on page 196
<b>Person</b> tab	<a href="#">Customer 360° Information - Person</a> on page 201
<b>Account</b> tab	<a href="#">Customer 360° Information - Account</a> on page 212
<b>Policy</b> tab	<a href="#">Customer 360° Information - Policy</a> on page 225
<b>Pricing</b> tab	<a href="#">Customer 360° Information - Pricing</a> on page 229
How to view the pricing information of a parent customer	<a href="#">Viewing the Pricing Information of a Parent Customer</a> on page 192
How to view the pricing information of a bill group	<a href="#">Viewing the Pricing Information of a Bill Group</a> on page 194
How to setup the <b>C1-ASOBLNG</b> feature configuration	<a href="#">Setting the C1-ASOBLNG Feature Configuration</a> on page 2889

## Viewing the 360° Information of an Account

### Prerequisites

To view the 360° information of an account, you should have:

- Value defined for the **Person Relationship Type** option type in the **C1-ASOBLNG** feature configuration
- Values defined for the **Administrative Contract Type** and **On Account Contract Type** option types in the **C1\_CMO** feature configuration
- Values defined for the **Premium Amount SQI** and **Coverage End Date SQI** option types in the **C1-BILLADJSQ** feature configuration

**Note:** The latter two prerequisites are not required when you are viewing the 360° information of a person who is associated with the self-funded policy.

### Procedure

To view the 360° information of an account:

1. Search for the account in the **Customer 360° View** screen.
2. In the **Search Results** section, click the **View** () icon corresponding to the account whose details you want to view.

The **Account** tab appears in the **Customer 360° Information** screen. It contains the following zones:

- [Account List](#) on page 213

**Note:** The **Account List** zone appears when you are viewing the 360° information of a person whose person type is set to **Parent Customer**.

- [Account Information](#) on page 214
- [Auto Pay Details](#) on page 217

- [Account Characteristics](#) on page 216
- [Administrative Contracts](#) on page 216

**Note:** The **Administrative Contracts** zone appears when you are viewing the 360° information of a person whose person type is neither **Parent Customer** nor **Bill Group**.

- [Account Financial and Collections Summary](#) on page 217
- [Billing and Adjustment Summary](#) on page 218

**Note:** The **Billing and Adjustment Summary** zone appears when you are viewing the 360° information of a person whose person type is neither **Parent Customer** nor **Bill Group**.

- [Open Bills](#) on page 219
  - [Billed Vs Paid](#) on page 220
  - [Timeline](#) on page 223
3. View the accounts of the parent customer and its bill groups in the **Account List** zone.
  4. View the basic details of the account in the **Account Information** zone.
  5. View the automatic payment options defined for the account in the **Auto Pay Details** zone.
  6. View the characteristics defined for the account in the **Account Characteristics** zone.
  7. View the account's contracts which should be monitored closely for various administrative reasons in the **Administrative Contracts** zone.
  8. View the financial and collection details of the account in the **Account Financial and Collections Summary** zone.
  9. View the billing and adjustment summary of the account in the **Billing and Adjustment Summary** zone.
  10. View the unpaid bills of the account in the **Open Bills** zone.
  11. View various transactions of the account, such as bills, payments, adjustments, reconciliations, and so on, in the **Billed Vs Paid** zone.
  12. View the number of customer contacts, bills, and payments created for the account in a particular month in the **Timeline** zone.

### Related Topics

For more information on...	See...
How to search for an account	<a href="#">Searching for an Account</a> on page 186
<b>Customer 360° Information</b> screen	<a href="#">Customer 360° Information</a> on page 196
<b>Account</b> tab	<a href="#">Customer 360° Information - Account</a> on page 212
How to setup the <b>C1_CMO</b> feature configuration	<a href="#">Setting the C1_CMO Feature Configuration</a> on page 2906
How to setup the <b>C1-ASOBLNG</b> feature configuration	<a href="#">Setting the C1-ASOBLNG Feature Configuration</a> on page 2889
How to setup the <b>C1-BILLADJSQ</b> feature configuration	<a href="#">Setting the C1-BILLADJSQ Feature Configuration</a> on page 2904

## Viewing the 360° Information of a Policy

### Procedure

To view the 360° information of a policy:

1. Search for the policy in the **Customer 360° View** screen.
2. In the **Search Results** section, click the **View** () icon corresponding to the policy whose details you want to view.

The **Policy** tab appears in the **Customer 360° Information** screen. It contains the following zones:

- [Policy List](#) on page 226

**Note:** The **Policy List** zone appears when there is more than one policy associated with the person.

- [Policy Information](#) on page 227
- [Policy Persons](#) on page 228
- [Policy Plans](#) on page 228

**Note:** The **Policy Plans** zone appears when you are viewing the 360° information of a person who is associated with the fully-insured group policy.

3. View the list of policies associated with the person in the **Policy List** zone.
4. View the basic details of the policy in the **Policy Information** zone.
5. View the persons associated with the policy in the **Policy Persons** zone.
6. View the plans defined in the policy in the **Policy Plans** zone.

#### Related Topics

For more information on...	See...
How to search for a policy	<a href="#">Searching for a Policy</a> on page 187
<b>Customer 360° Information</b> screen	<a href="#">Customer 360° Information</a> on page 196
<b>Policy</b> tab	<a href="#">Customer 360° Information - Policy</a> on page 225

## Viewing the Pricing Information of a Parent Customer

### Prerequisites

To view the pricing information of a parent customer, you should have:

- Value defined for the **Person Relationship Type** option type in the **C1-ASOBLLNG** feature configuration

### Procedure

To view the pricing information of a parent customer:

1. Search for a person whose person type is set to **Parent Customer** in the **Customer 360° View** screen.
2. In the **Search Results** section, click the **View** () icon corresponding to the person whose details you want to view.

The **Person** tab appears in the **Customer 360° Information** screen.

3. Click the **Pricing** tab.

The **Pricing** tab appears. It contains the following zones:

- [Parent Customer Pricing Rules](#) on page 231
- [Bill Group ASO Policy Pricing Rule Summary](#) on page 234



**Note:** The **Bill Group ASO Policy Pricing Rule Summary** zone appears when you are viewing 360° information of a parent customer who is associated with the self-funded policy.

- [Bill Group ASO Policy Information](#) on page 236

**Note:** The **Bill Group ASO Policy Information** zone appears when you are viewing 360° information of a parent customer who is associated with the self-funded policy.

- [Bill Group ASO Policy Pricing Rules](#) on page 237

**Note:** The **Bill Group ASO Policy Pricing Rules** zone appears when you are viewing 360° information of a parent customer who is associated with the self-funded policy.

- [Policy Plan Pricing Rule Summary](#) on page 244

**Note:** The **Policy Plan Pricing Rule Summary** zone appears when you are viewing 360° information of a parent customer who is associated with the fully-insured group policy.

- [Policy Plan Information](#) on page 245

**Note:** The **Policy Plan Information** zone appears when you are viewing 360° information of a parent customer who is associated with the fully-insured group policy.

- [Policy Plan Pricing Rules](#) on page 246

**Note:** The **Policy Plan Pricing Rules** zone appears when you are viewing 360° information of a parent customer who is associated with the fully-insured group policy.

- [Pricing Rule Approval Transactions](#) on page 243

4. Do either of the following:

If you are viewing 360° information of...	Then...
A parent customer who is associated with the self-funded policy	<ol style="list-style-type: none"> <li>1. View the pricing rules which are defined for the parent customer in the <b>Parent Customer Pricing Rules</b> zone.</li> <li>2. View the list of pricing rules which are defined for the self-funded policies of the bill groups in the <b>Bill Group ASO Policy Pricing Rule Summary</b> zone.</li> <li>3. View the details of the policies to which a bill group is associated in the <b>Bill Group ASO Policy Information</b> zone.</li> <li>4. View the details of the pricing rules which are defined for a policy of a bill group in the <b>Bill Group ASO Policy Pricing Rules</b> zone.</li> <li>5. View the details of the pricing groups which are defined for a bill group in the <b>Bill Group Pricing Groups</b> zone.</li> <li>6. View the approval transactions which are created while defining, editing, or deleting a pricing rule of the parent customer and its</li> </ol>

If you are viewing 360° information of...	Then...
	bill groups in the <b>Pricing Rule Approval Transactions</b> zone.
A parent customer who is associated with the fully-insured group policy	<ol style="list-style-type: none"> <li>1. View the list of pricing rules which are defined for the policy plans in the <b>Policy Plan Pricing Rule Summary</b> zone.</li> <li>2. View the list of policy plans available in the fully-insured group policies of the parent customer and/or its bill groups in the <b>Policy Plan Information</b> zone.</li> <li>3. View the pricing rules which are defined for the policy plans in the <b>Policy Plan Pricing Rules</b> zone.</li> <li>4. View the approval transactions which are created while defining, editing, or deleting a pricing rule of a policy plan in the <b>Pricing Rule Approval Transactions</b> zone.</li> </ol>

### Related Topics

For more information on...	See...
How to search for a person	<a href="#">Searching for a Person</a> on page 185
<b>Customer 360° Information</b> screen	<a href="#">Customer 360° Information</a> on page 196
<b>Pricing</b> tab	<a href="#">Customer 360° Information - Pricing</a> on page 229
How to setup the <b>C1-ASOBLLNG</b> feature configuration	<a href="#">Setting the C1-ASOBLLNG Feature Configuration</a> on page 2889

## Viewing the Pricing Information of a Bill Group

### Prerequisites

To view the pricing information of a bill group, you should have:

- Value defined for the **Person Relationship Type** option type in the **C1-ASOBLLNG** feature configuration

### Procedure

To view the pricing information of a bill group:

1. Search for a person whose person type is set to **Bill Group** in the **Customer 360° View** screen.
2. In the **Search Results** section, click the **View** () icon corresponding to the person whose details you want to view.

The **Person** tab appears in the **Customer 360° Information** screen.

3. Click the **Pricing** tab.

The **Pricing** tab appears. It contains the following zones:

- [Parent Customer Pricing Rule Summary](#) on page 235
- [Bill Group ASO Policy Information](#) on page 236

**Note:** The **Bill Group ASO Policy Information** zone appears when you are viewing 360° information of a bill group who is associated with the self-funded policy.

- [Bill Group ASO Policy Pricing Rules](#) on page 237

**Note:** The **Bill Group ASO Policy Pricing Rules** zone appears when you are viewing 360° information of a bill group who is associated with the self-funded policy.

- [Policy Plan Pricing Rule Summary](#) on page 244

**Note:** The **Policy Plan Pricing Rule Summary** zone appears when you are viewing 360° information of a bill group who is associated with the fully-insured group policy.

- [Policy Plan Information](#) on page 245

**Note:** The **Policy Plan Information** zone appears when you are viewing 360° information of a bill group who is associated with the fully-insured group policy.

- [Policy Plan Pricing Rules](#) on page 246

**Note:** The **Policy Plan Pricing Rules** zone appears when you are viewing 360° information of a bill group who is associated with the fully-insured group policy.

- [Bill Group Pricing Groups](#) on page 242

**Note:** The **Bill Group Pricing Groups** zone appears when you are viewing 360° information of a bill group who is associated with the self-funded policy.

- [Pricing Rule Approval Transactions](#) on page 243

4. Do either of the following:

If you are viewing 360° information of...	Then...
A bill group who is associated with the self-funded policy	<ol style="list-style-type: none"> <li>1. View a list of pricing rules which are defined for the parent customer in the <b>Parent Customer Pricing Rule Summary</b> zone.</li> <li>2. View the details of the policies to which the bill group is associated in the <b>Bill Group ASO Policy Information</b> zone.</li> <li>3. View the details of the pricing rules which are defined for a policy of the bill group in the <b>Bill Group ASO Policy Pricing Rules</b> zone.</li> <li>4. View the details of the pricing groups which are defined for the bill group in the <b>Bill Group Pricing Groups</b> zone.</li> <li>5. View the approval transactions which are created while defining, editing, or deleting the pricing rules of the bill group in the <b>Pricing Rule Approval Transactions</b> zone.</li> </ol>
A bill group who is associated with the fully-insured group policy	<ol style="list-style-type: none"> <li>1. View the list of pricing rules which are defined for the policy plans in the <b>Policy Plan Pricing Rule Summary</b> zone.</li> <li>2. View the list of policy plans available in the fully-insured group policies of the bill group in the <b>Policy Plan Information</b> zone.</li> </ol>

If you are viewing 360° information of...	Then...
	<ol style="list-style-type: none"> <li>3. View the pricing rules which are defined for the policy plans in the <b>Policy Plan Pricing Rules</b> zone.</li> <li>4. View the approval transactions which are created while defining, editing, or deleting a pricing rule of a policy plan in the <b>Pricing Rule Approval Transactions</b> zone.</li> </ol>

### **Related Topics**

For more information on...	See...
How to search for a person	<a href="#">Searching for a Person</a> on page 185
<b>Customer 360° Information</b> screen	<a href="#">Customer 360° Information</a> on page 196
<b>Pricing</b> tab	<a href="#">Customer 360° Information - Pricing</a> on page 229
How to setup the <b>C1-ASOBLNG</b> feature configuration	<a href="#">Setting the C1-ASOBLNG Feature Configuration</a> on page 2889

## **Customer 360° Information**

---

The following table provides information about the **Customer 360° Information** screen:

If you are viewing the 360° information of...	Then
<p>A parent customer who is associated with the self-funded policy</p>	<p>The <b>Customer 360° Information</b> screen allows you to view:</p> <ul style="list-style-type: none"> <li>• Basic details, characteristics, child persons, billing hierarchy, and customer contacts of the parent customer.</li> <li>• Sort IDs of all effective child persons whose person type is set to <b>Bill Group</b> and who are related to the parent customer using a relationship type which is specified in the <b>Person Relationship Type</b> option type of the <b>C1-ASOBLNG</b> feature configuration.</li> <li>• Derivation and pricing parameters defined for the bill group and sort ID combinations.</li> <li>• Customer registration objects through which the bill groups are created for the parent customer.</li> <li>• Accounts of all effective child persons whose person type is set to <b>Bill Group</b> and who are related to the parent customer using a relationship type which is specified in the <b>Person Relationship Type</b> option type of the <b>C1-ASOBLNG</b> feature configuration.</li> <li>• Basic details, characteristics, automatic payment options, financial and collections summary, and unpaid bills of a particular bill group's account.</li> <li>• List of self-funded policies to which the parent customer's bill groups are associated.</li> <li>• Basic details and policy persons of a self-funded policy where the parent customer is the policy holder.</li> <li>• Basic details of the pricing rules which are defined for the parent customer.</li> <li>• Summarized tree view listing each bill group of the parent customer and the bill groups' self-funded policies and pricing rules.</li> <li>• Basic details of the self-funded policies which are associated with each bill group of the parent customer.</li> <li>• Basic details of the pricing rules which are defined for the self-funded policies of each bill group.</li> <li>• Basic details of the active pricing groups which are defined for each bill group.</li> <li>• Basic information about the approval transactions which are created while defining, editing, and deleting the parent customer's and bill groups' pricing rules.</li> </ul>

If you are viewing the 360° information of...	Then
A bill group who is associated with the self-funded policy	<p>The <b>Customer 360° Information</b> screen allows you to view:</p> <ul style="list-style-type: none"> <li>• Basic details, characteristics, child persons, billing hierarchy, and customer contacts of the bill group.</li> <li>• Basic details, characteristics, automatic payment options, financial and collections summary, and unpaid bills of the bill group's account.</li> <li>• List of self-funded policies to which the bill group is associated.</li> <li>• Basic details and policy persons of a self-funded policy.</li> <li>• Summarized tree view listing the parent customer and pricing rules which are defined for the parent customer.</li> <li>• Basic details of the self-funded policies which are associated with the bill group.</li> <li>• Basic details of the pricing rules which are defined for the self-funded policies of the bill group.</li> <li>• Basic details of the active pricing groups which are defined for the bill group.</li> <li>• Basic information about the approval transactions which are created while defining, editing, and deleting the pricing rules of the bill group.</li> </ul>

If you are viewing the 360° information of...	Then
<p>A parent customer who is associated with the fully-insured group policy</p>	<p>The <b>Customer 360° Information</b> screen allows you to view:</p> <ul style="list-style-type: none"> <li>• Basic details, characteristics, child persons, billing hierarchy, and customer contacts of the parent customer.</li> <li>• Sort IDs of all effective child persons whose person type is set to <b>Bill Group</b> and who are related to the parent customer using a relationship type which is specified in the <b>Person Relationship Type</b> option type of the <b>C1-ASOBLLNG</b> feature configuration.</li> <li>• Derivation and pricing parameters defined for the bill group and sort ID combinations.</li> <li>• Customer registration objects through which the bill groups are created for the parent customer.</li> <li>• List of the parent customer's and bill groups' accounts. Note that the system lists the accounts of all effective child persons whose person type is set to <b>Bill Group</b> and who are related to the parent customer using a relationship type which is specified in the <b>Person Relationship Type</b> option type of the <b>C1-ASOBLLNG</b> feature configuration.</li> <li>• Basic details, characteristics, automatic payment options, financial and collections summary, and unpaid bills of the parent customer's or bill group's account.</li> <li>• List of fully-insured group policies to which the parent customer or its bill groups are associated.</li> <li>• Basic details, policy persons, and policy plans of a fully insured group policy to which the parent customer or its bill group is associated.</li> <li>• Summarized tree view listing the fully-insured group policies of the parent customer and its bill group along with their respective policy plans and pricing rules.</li> <li>• Basic policy plan details of the fully-insured group policy to which the parent customer or its bill group is associated.</li> <li>• Basic details of the pricing rules which are defined for the fully-insured group policy plans.</li> <li>• Basic information about the approval transactions which are created while defining, editing, and deleting a pricing rule of a policy plan.</li> </ul>

If you are viewing the 360° information of...	Then
A bill group who is associated with the fully-insured group policy	<p>The <b>Customer 360° Information</b> screen allows you to view:</p> <ul style="list-style-type: none"> <li>• Basic details, characteristics, child persons, billing hierarchy, and customer contacts of the bill group.</li> <li>• Basic details, characteristics, automatic payment options, financial and collections summary, and unpaid bills of the bill group's account.</li> <li>• List of fully-insured group policies to which the bill group is associated.</li> <li>• Basic details, policy persons, and policy plans of a fully insured group policy.</li> <li>• Summarized tree view listing the fully-insured group policies of the bill group along with their respective policy plans and pricing rules.</li> <li>• Basic policy plan details of the fully-insured group policy to which the bill group is associated.</li> <li>• Basic details of the pricing rules which are defined for the fully-insured group policy plans.</li> <li>• Basic information about the approval transactions which are created while defining, editing, and deleting a pricing rule of a policy plan.</li> </ul>
A person whose person type is neither <b>Parent Customer</b> nor <b>Bill Group</b>	<p>The <b>Customer 360° Information</b> screen allows you to view:</p> <ul style="list-style-type: none"> <li>• Basic details, characteristics, child persons, billing hierarchy, and customer contacts of the person.</li> <li>• Basic details, characteristics, automatic payment options, administrative contracts, financial and collections summary, billing and adjustment summary, and unpaid bills of the person's account.</li> <li>• List of policies to which the person is associated.</li> <li>• Basic details, policy persons, and policy plans of a policy.</li> </ul>

This screen consists of the following tabs:

- [Customer 360° Information - Person](#) on page 201
- [Customer 360° Information - Account](#) on page 212
- [Customer 360° Information - Policy](#) on page 225
- [Customer 360° Information - Pricing](#) on page 229

**Note:** If a person does not have an account or policy, the data does not appear in the **Account** or **Policy** tab, respectively. And, if the pricing rules are not defined for the parent customer, bill group's policy, or fully-insured group policy plan, the data does not appear in the **Pricing** tab.



## Customer 360° Information - Person

The following table provides information about the **Person** tab:

If you are viewing the 360° information of...	Then...
A parent customer who is associated with the self-funded or fully-insured group policy	<p>The <b>Person</b> tab displays the following:</p> <ul style="list-style-type: none"> <li>• Basic details, characteristics, child persons, billing hierarchy, and customer contacts of the parent customer.</li> <li>• Sort IDs of all effective child persons whose person type is set to <b>Bill Group</b> and who are related to the parent customer using a relationship type which is specified in the <b>Person Relationship Type</b> option type of the <b>C1-ASOBLLNG</b> feature configuration.</li> <li>• Derivation and pricing parameters defined for the bill group and sort ID combinations.</li> <li>• Customer registration objects through which the bill groups are created for the parent customer.</li> </ul>
A bill group who is associated with the self-funded or fully insured group policy	The <b>Person</b> tab displays the basic details, characteristics, child persons, billing hierarchy, and customer contacts of the bill group.
A person whose person type is neither <b>Parent Customer</b> nor <b>Bill Group</b>	The <b>Person</b> tab displays the basic details, characteristics, child persons, billing hierarchy, and customer contacts of the person.

It contains the following zones:

- [Person Information](#) on page 202
- [Person Characteristics](#) on page 203
- [Child Persons](#) on page 204
- [Person Hierarchy](#) on page 204

**Note:** The **Person Hierarchy** zone does not appear when you are viewing the 360° information of a person whose person type is set to **Parent Customer**.

- [Person Billing Hierarchy](#) on page 205

**Note:** The **Person Billing Hierarchy** zone appears when you are viewing the 360° information of a person whose person type is set to **Parent Customer**.

- [Bill Group Derivation and Pricing Parameters](#) on page 208

**Note:** The **Bill Group Derivation and Pricing Parameters** zone appears when you are viewing the 360° information of a person whose person type is set to **Parent Customer**.

- [Bill Group Sorting](#) on page 210

**Note:** The **Bill Group Sorting** zone appears when you are viewing the 360° information of a person whose person type is set to **Parent Customer**.

- [Customer Contacts](#) on page 211
- [Bill Groups Created Via Customer Registration](#) on page 212

**Note:** The **Bill Groups Created Via Customer Registration** zone appears when you are viewing the 360° information of a person whose person type is set to **Parent Customer**.

### Related Topics

For more information on...	See...
How to view the 360° information of a person	<a href="#">Viewing the 360° Information of a Person</a> on page 188
How to setup the <b>C1-ASOBLNG</b> feature configuration	<a href="#">Setting the C1-ASOBLNG Feature Configuration</a> on page 2889

### Person Information

The **Person Information** zone displays the details of the person. It contains the following sections:

- **Main** - Displays the basic information about the person. It contains the following fields:

Field Name	Field Description
Person Information	Displays information about the person. In addition, a context menu appears corresponding to this field which helps in navigating to other screens in the application.  <b>Note:</b> It has a link. On clicking the link, the <b>Person</b> screen appears where you can view the details of the person.
Person Type	Indicates the type of the person. The valid values are: <ul style="list-style-type: none"> <li>• Business</li> <li>• Bill Group</li> <li>• Group</li> <li>• Broker</li> <li>• Person</li> <li>• Parent Customer</li> </ul>
Date of Birth	Displays the date when the person was born.  <b>Note:</b> This field appears only when the respective data is available for the person.

- **Person Identifiers** - Lists various types of identification associated with the person. It contains the following columns:

Column Name	Column Description
Person Identifier Type	Indicates the person identifier type.
Person Identifier	Displays the value of the person identifier type.

- **Contact Information** - Displays the contact details of the person. It contains the following fields:

Field Name	Field Description
Country	Indicates the country where the person is located.
Address 1	Displays the first line of the person's address. It may contain details, such as house number and apartment name.

Field Name	Field Description
Address 2	Displays the second line of the person's address. It may contain details, such as street name.
Address 3	Displays the third line of the person's address. It may contain the landmark details.
Address 4	Displays the fourth line of the person's address.
House Type	Indicates the type of the house.
Number 1	Displays the numeric information, if any, related to the address.
Number 2	Displays the numeric information, if any, related to the address.
In City Limit	Indicates whether the person resides within the city limit or not. The valid values are: <ul style="list-style-type: none"> <li>• Yes</li> <li>• No</li> </ul>
City	Displays the city where the person is located.
Geographic Code	Displays the geographic code of the address.
County	Displays the county where the person is located.
State	Indicates the state where the city or county is located.
Postal	Displays the postal or zip code of the address.
Email ID	Displays the e-mail ID of the person.

**Note:** The above mentioned fields appear in the **Contact Information** section only when the respective data is available for the person.

- **Phone Details** – Lists the phone details of the person. It contains the following columns:

Column Name	Column Description
Phone Type	Indicates the type of the phone number.
Phone Number	Displays the phone number of the person.

### Person Characteristics

The **Person Characteristics** zone lists the characteristics defined for the person. It contains the following columns:

Column Name	Column Description
Effective Date	Displays the date from when the characteristic is effective for the person.
Characteristic Type	Indicates the characteristic type.
Characteristic Value	Displays the value of the characteristic type.
Description	Displays the description of the characteristic value. <div style="border: 1px solid black; padding: 5px; margin-top: 10px;"> <p><b>Note:</b> The data appears in this column only when the type of characteristic value is set to <b>Predefined Value</b> or <b>Foreign Key Value</b>.</p> </div>

You can filter the list using the **Characteristic Type** field available in the **Filter** area. By default, the **Filter** area is hidden. You can view the **Filter** area by clicking the **Filters** () icon in the upper right corner of this zone.

## Child Persons

The **Child Persons** zone lists the child persons included in the person's hierarchy. It contains the following columns:

Column Name	Column Description
Child Person Information	Displays information about the child person. <b>Note:</b> It has a link. On clicking the link, the <b>Person</b> screen appears where you can view the details of the child person.
Relationship Type	Indicates how the child person is related to the parent person.
Start Date	Displays the date from when the child person is related to the parent person.
End Date	Displays the date till when the child person is related to the parent person.

**Note:** Pagination is used to display limited number of records in this zone. You can use the navigation links, such as **Previous** and **Next** to navigate between pages.

You can view the 360° information of a child person by clicking the **View** () icon corresponding to the child person in this zone.

You can create a new child person through the **Customer Registration** feature by clicking the **Add** link in the upper right corner of this zone. While adding a child person to a parent person, the child person is related to the parent person using the relationship type which is specified in the **Person Relationship Type** option type of the **C1-ASOBLNG** feature configuration.

You can filter the list using the **Person Relationship Type** field available in the **Filter** area. By default, the **Filter** area is hidden. You can view the **Filter** area by clicking the **Filters** () icon in the upper right corner of this zone.

## Related Topics

For more information on...	See...
How to setup the <b>C1-ASOBLNG</b> feature configuration	<a href="#">Setting the C1-ASOBLNG Feature Configuration</a> on page 2889

## Person Hierarchy

The **Person Hierarchy** zone lists the following in a tree view:

- Information string of accounts where the person is the main customer
- Information string of policies where the person is associated
- Information string of membership where the person is the main subscriber
- Information string of the parent persons

It does not appear when you are viewing the 360° information of a person whose person type is set to **Parent Customer**. It contains the following column:

Column Name	Column Description												
Hierarchy	<p data-bbox="597 212 1468 306">Displays information about the person, account, policy, membership, and parent person in a tree view. Each node in the tree view has a link. The following table indicates the information string that appears in various scenarios:</p> <table border="1" data-bbox="597 327 1468 1356"> <thead> <tr> <th data-bbox="597 327 1036 380">If...</th> <th data-bbox="1036 327 1468 380">Then...</th> </tr> </thead> <tbody> <tr> <td data-bbox="597 380 1036 590">The person is the main customer of an account</td> <td data-bbox="1036 380 1468 590">The account information string appears. It has a link. On clicking the link, the 360° information of the account appears in the <b>Account</b> tab of the <b>Customer 360° Information</b> screen.</td> </tr> <tr> <td data-bbox="597 590 1036 768">The person is associated with a policy</td> <td data-bbox="1036 590 1468 768">The policy information string appears. It has a link. On clicking the link, the 360° information of the policy appears in the <b>Policy</b> tab of the <b>Customer 360° Information</b> screen.</td> </tr> <tr> <td data-bbox="597 768 1036 978">The person is the main subscriber in a membership</td> <td data-bbox="1036 768 1468 978">The membership information string appears. It has a link. On clicking the link, the <b>Membership Information</b> screen appears where you can view the details of the respective membership.</td> </tr> <tr> <td data-bbox="597 978 1036 1157">The person is associated with a policy and is the main subscriber in a membership of its policy plan</td> <td data-bbox="1036 978 1468 1157">The policy information string appears. It has a link. On clicking the link, the 360° information of the policy appears in the <b>Policy</b> tab of the <b>Customer 360° Information</b> screen.</td> </tr> <tr> <td data-bbox="597 1157 1036 1356">The person has a parent person</td> <td data-bbox="1036 1157 1468 1356">The person information string appears. It has a link. On clicking the link, the 360° information of the person appears in the <b>Person</b> tab of the <b>Customer 360° Information</b> screen.</td> </tr> </tbody> </table>	If...	Then...	The person is the main customer of an account	The account information string appears. It has a link. On clicking the link, the 360° information of the account appears in the <b>Account</b> tab of the <b>Customer 360° Information</b> screen.	The person is associated with a policy	The policy information string appears. It has a link. On clicking the link, the 360° information of the policy appears in the <b>Policy</b> tab of the <b>Customer 360° Information</b> screen.	The person is the main subscriber in a membership	The membership information string appears. It has a link. On clicking the link, the <b>Membership Information</b> screen appears where you can view the details of the respective membership.	The person is associated with a policy and is the main subscriber in a membership of its policy plan	The policy information string appears. It has a link. On clicking the link, the 360° information of the policy appears in the <b>Policy</b> tab of the <b>Customer 360° Information</b> screen.	The person has a parent person	The person information string appears. It has a link. On clicking the link, the 360° information of the person appears in the <b>Person</b> tab of the <b>Customer 360° Information</b> screen.
If...	Then...												
The person is the main customer of an account	The account information string appears. It has a link. On clicking the link, the 360° information of the account appears in the <b>Account</b> tab of the <b>Customer 360° Information</b> screen.												
The person is associated with a policy	The policy information string appears. It has a link. On clicking the link, the 360° information of the policy appears in the <b>Policy</b> tab of the <b>Customer 360° Information</b> screen.												
The person is the main subscriber in a membership	The membership information string appears. It has a link. On clicking the link, the <b>Membership Information</b> screen appears where you can view the details of the respective membership.												
The person is associated with a policy and is the main subscriber in a membership of its policy plan	The policy information string appears. It has a link. On clicking the link, the 360° information of the policy appears in the <b>Policy</b> tab of the <b>Customer 360° Information</b> screen.												
The person has a parent person	The person information string appears. It has a link. On clicking the link, the 360° information of the person appears in the <b>Person</b> tab of the <b>Customer 360° Information</b> screen.												

### Person Billing Hierarchy

The following table lists the information which appears in the **Person Billing Hierarchy** zone:

If you are viewing the 360° information of a...	Then...
Parent Customer	<p>The following information appears in a tree view:</p> <ul style="list-style-type: none"> <li>• Information string of each policy to which the parent customer is associated.</li> <li>• Information string of each account where the parent customer is the main customer.</li> <li>• Information string of each effective child person whose person type is set to <b>Bill Group</b>) and who is related to the parent customer using a relationship type which is specified in the <b>Person Relationship Type</b> option type of the <b>C1-ASOBLNG</b> feature configuration</li> <li>• Information string of each policy to which the bill group is associated.</li> <li>• Information string of each account where the bill group is the main customer.</li> </ul>
Bill Group	<p>The following information appears in a tree view:</p> <ul style="list-style-type: none"> <li>• Information string of each account where the bill group is the main customer.</li> <li>• Information string of each policy to which the bill group is associated.</li> <li>• Information string of the parent person</li> </ul>

It appears when you are viewing the 360° information of a person whose person type is set to **Parent Customer**. It contains the following column:

Column Name	Column Description												
Hierarchy	If you are viewing the 360° information of a parent customer, the following table indicates the information string that appears in various scenarios:												
	<table border="1"> <thead> <tr> <th>If...</th> <th>Then...</th> </tr> </thead> <tbody> <tr> <td>The parent customer is associated with a policy</td> <td>The policy information string appears. It has a link. On clicking the link, the 360° information of the policy appears in the <b>Policy</b> tab of the <b>Customer 360° Information</b> screen.</td> </tr> <tr> <td>The parent customer is the main customer of an account</td> <td>The account information string appears. It has a link. On clicking the link, the 360° information of the account appears in the <b>Account</b> tab of the <b>Customer 360° Information</b> screen.</td> </tr> <tr> <td>The parent customer has a bill group</td> <td>The person information string appears. It has a link. On clicking the link, the 360° information of the bill group appears in the <b>Person</b> tab of the <b>Customer 360° Information</b> screen.</td> </tr> <tr> <td>A bill group is the main customer of an account</td> <td>The account information string appears. It has a link. On clicking the link, the 360° information of the account appears in the <b>Account</b> tab of the <b>Customer 360° Information</b> screen.</td> </tr> <tr> <td>A bill group is associated with a policy</td> <td>The policy information string appears. It has a link. On clicking the link, the 360° information of the policy appears in the <b>Policy</b> tab of the <b>Customer 360° Information</b> screen.</td> </tr> </tbody> </table>	If...	Then...	The parent customer is associated with a policy	The policy information string appears. It has a link. On clicking the link, the 360° information of the policy appears in the <b>Policy</b> tab of the <b>Customer 360° Information</b> screen.	The parent customer is the main customer of an account	The account information string appears. It has a link. On clicking the link, the 360° information of the account appears in the <b>Account</b> tab of the <b>Customer 360° Information</b> screen.	The parent customer has a bill group	The person information string appears. It has a link. On clicking the link, the 360° information of the bill group appears in the <b>Person</b> tab of the <b>Customer 360° Information</b> screen.	A bill group is the main customer of an account	The account information string appears. It has a link. On clicking the link, the 360° information of the account appears in the <b>Account</b> tab of the <b>Customer 360° Information</b> screen.	A bill group is associated with a policy	The policy information string appears. It has a link. On clicking the link, the 360° information of the policy appears in the <b>Policy</b> tab of the <b>Customer 360° Information</b> screen.
	If...	Then...											
	The parent customer is associated with a policy	The policy information string appears. It has a link. On clicking the link, the 360° information of the policy appears in the <b>Policy</b> tab of the <b>Customer 360° Information</b> screen.											
	The parent customer is the main customer of an account	The account information string appears. It has a link. On clicking the link, the 360° information of the account appears in the <b>Account</b> tab of the <b>Customer 360° Information</b> screen.											
	The parent customer has a bill group	The person information string appears. It has a link. On clicking the link, the 360° information of the bill group appears in the <b>Person</b> tab of the <b>Customer 360° Information</b> screen.											
	A bill group is the main customer of an account	The account information string appears. It has a link. On clicking the link, the 360° information of the account appears in the <b>Account</b> tab of the <b>Customer 360° Information</b> screen.											
	A bill group is associated with a policy	The policy information string appears. It has a link. On clicking the link, the 360° information of the policy appears in the <b>Policy</b> tab of the <b>Customer 360° Information</b> screen.											
	However, if you are viewing the 360° information of a bill group, the following table indicates the information string that appears in various scenarios:												
	<table border="1"> <thead> <tr> <th>If...</th> <th>Then...</th> </tr> </thead> <tbody> <tr> <td>The bill group is the main customer of an account</td> <td>The account information string appears. It has a link. On clicking the link, the 360° information of the account appears in the <b>Account</b> tab of the <b>Customer 360° Information</b> screen.</td> </tr> <tr> <td>The bill group is associated with a policy</td> <td>The policy information string appears. It has a link. On clicking the link, the 360° information of the policy appears in the <b>Policy</b> tab of the <b>Customer 360° Information</b> screen.</td> </tr> <tr> <td>The bill group has a parent person</td> <td>The person information string appears. It has a link. On clicking the link, the 360° information of the parent customer appears in the <b>Person</b> tab of the <b>Customer 360° Information</b> screen.</td> </tr> </tbody> </table>	If...	Then...	The bill group is the main customer of an account	The account information string appears. It has a link. On clicking the link, the 360° information of the account appears in the <b>Account</b> tab of the <b>Customer 360° Information</b> screen.	The bill group is associated with a policy	The policy information string appears. It has a link. On clicking the link, the 360° information of the policy appears in the <b>Policy</b> tab of the <b>Customer 360° Information</b> screen.	The bill group has a parent person	The person information string appears. It has a link. On clicking the link, the 360° information of the parent customer appears in the <b>Person</b> tab of the <b>Customer 360° Information</b> screen.				
	If...	Then...											
	The bill group is the main customer of an account	The account information string appears. It has a link. On clicking the link, the 360° information of the account appears in the <b>Account</b> tab of the <b>Customer 360° Information</b> screen.											
	The bill group is associated with a policy	The policy information string appears. It has a link. On clicking the link, the 360° information of the policy appears in the <b>Policy</b> tab of the <b>Customer 360° Information</b> screen.											
	The bill group has a parent person	The person information string appears. It has a link. On clicking the link, the 360° information of the parent customer appears in the <b>Person</b> tab of the <b>Customer 360° Information</b> screen.											

### Related Topics

For more information on...	See...
How to setup the <b>C1-ASOBLNG</b> feature configuration	<a href="#">Setting the CI-ASOBLNG Feature Configuration</a> on page 2889

## Bill Group Derivation and Pricing Parameters

An employer may have different bill groups. Each bill group will handle the claim and enrollment transactions of employees based on the employee attributes, such as location, employment status, employment department, and so on.

Oracle Revenue Management and Billing allows you to define the derivation and pricing parameters, such as source system, parameter 1, parameter 2, parameter 3, and parameter 4 for the bill group and sort ID combination. These parameters are used to derive the bill group against which the claim and enrollment transactions should be billed in the system. For example, if you want bill group 1 to handle claim and enrollment transactions of employees who reside in the western location of city and belong to grade A and whose transactions are received from the X system, you need to define the derivation and pricing parameters for bill group 1 where the source system is set to X, parameter 1 is set to Western, and parameter 2 is set to Grade A. Similarly, if you want bill group 2 to handle claim and enrollment transactions of employees who reside in the eastern location of city and belong to grade A and whose transactions are received from the X system, you need to define the derivation and pricing parameters for bill group 2 where the source system is set to X, parameter 1 is set to Eastern, and parameter 2 is set to Grade A.

**Note:** In the above examples, the bill group is derived based on the specified attributes only when the source system, parameter 1, and parameter 2 are mapped to the appropriate transaction fields in the pricing rule type using which the pricing rules are defined for the bill group.

You can also define criteria for a rule in a pricing group using the parameters, such as source system, parameter 1, parameter 2, parameter 3, and parameter 4. If a pricing rule is defined for a bill group using a pricing group, you can define more than one price in the pricing rule which is offered based on the attributes of the employees.

The derivation and pricing parameters for the bill group and sort ID combination are effective from a particular date. However, the effective date must fall within the date range defined for the sort ID of the bill group.

The **Bill Group Derivation and Pricing Parameters** zone lists the derivation and pricing parameters defined for all effective child persons whose person type is set to **Bill Group** and who are related to the parent customer using a relationship type which is specified in the **Person Relationship Type** option type of the **C1-ASOBLLNG** feature configuration. It appears when you are viewing the 360° information of a person whose person type is set to **Parent Customer**.

You can define and edit the derivation and pricing parameters for a bill group (who is effective child person of the parent customer) and sort ID combination through this zone. You can also upload the derivation and pricing parameters for one or more bill group and sort ID combinations at the same time using the **Upload Request** feature. You can upload the derivation and pricing parameters for a bill group and sort ID combination either from this zone or from the **Upload Request** screen. While creating an upload request for the derivation and pricing parameters, you need to specify the parent customer whose bill groups' derivation and pricing parameters you want to upload. Once the upload request is processed, the derivation and pricing parameters are defined for the bill group and sort ID combination in the system.

This zone contains the following columns:

Column Name	Column Description
Bill Group Information	Indicates the parent customer's bill group for whom the derivation and pricing parameters are defined. In addition, a context menu appears corresponding to this column which helps in navigating to other screens in the application.  <b>Note:</b> It has a link. On clicking the link, the <b>Person</b> screen appears where you can view the details of the respective bill group (i.e. person).
Bill Group ID	Displays the bill group ID (i.e. person ID).
Source System	Indicates the source system from where the claim and enrollment transactions are received.
Parameter 1	Indicates the employee attribute based on which you want to derive the bill group.
Parameter 2	Indicates the employee attribute based on which you want to derive the bill group.



Column Name	Column Description
Parameter 3	Indicates the employee attribute based on which you want to derive the bill group.
Parameter 4	Indicates the employee attribute based on which you want to derive the bill group.
Sort ID	Indicates the sort ID of the bill group.
Effective Date	Displays the date from when the derivation and pricing parameters are effective for the bill group and sort ID combination.
Status	Indicates the status of the derivation and pricing parameters defined for the bill group and sort ID combination. The valid values are: <ul style="list-style-type: none"> <li>Active</li> <li>Inactive</li> </ul>

In addition, it contains the following buttons:

Button Name	Button Description
Edit	Used to edit the derivation and pricing parameters of a bill group and sort ID combination.

If you want to edit the derivation and pricing parameters of all bill group and sort ID combinations, you need to select the check box corresponding to the column header in this zone, and then click the **Edit** button. However, if you want to edit the derivation and pricing parameters of one or more bill group and sort ID combination, you need to select the check box corresponding to the bill group and sort ID combination, and then click the **Edit** button.

**Note:**

Pagination is used to display limited number of records in this zone. You can use the navigation links, such as **Previous** and **Next** to navigate between pages.

If you select the check box corresponding to the column header in this zone, the system considers only those records which are present on the respective page for editing.

You can define the derivation and pricing parameters for a bill group (who is effective child person of the parent customer) and sort ID combination by clicking the **Add** link in the upper right corner of this zone. You can also upload the derivation and pricing parameters for one or more bill group (who is effective child person of the parent customer) and sort ID combinations by clicking the **Upload** link in the upper right corner of this zone.

You can filter the list using various search criteria (such as, **Parameter 1, Parameter 2, Parameter 3, Parameter 4, Bill Group ID, Sort ID, Status, and Bill Group Name**) available in the **Filter** area. By default, the **Filter** area is hidden. You can view the **Filter** area by clicking the **Filters** () icon in the upper right corner of this zone.

You can change the layout of this zone. For more information on how to change the layout, see [Changing the Layout](#) on page 2882.

**Related Topics**

For more information on...	See...
How to define the derivation and pricing parameters for a bill group and sort ID combination	<a href="#">Defining the Derivation and Pricing Parameters for a Bill Group and Sort ID Combination</a> on page 252
How to edit the derivation and pricing parameters of a bill group and sort ID combination	<a href="#">Editing the Derivation and Pricing Parameters of a Bill Group and Sort ID Combination</a> on page 255
How to create an upload request for the derivation and pricing parameters from the <b>Bill Group Derivation and Pricing Parameters</b> zone	<a href="#">Creating a Bill Group Derivation and Pricing Parameters Upload Request</a> on page 256

For more information on...	See...
How to create an upload request for the derivation and pricing parameters from the <b>Upload Request</b> screen	<a href="#">Creating an Upload Request</a> on page 1660
How to setup the <b>C1-ASOBLNG</b> feature configuration	<a href="#">Setting the C1-ASOBLNG Feature Configuration</a> on page 2889

## Bill Group Sorting

Oracle Revenue Management and Billing allows you to define unique sort IDs for a bill group in a given date range. In future, the sort ID will be used to club transactions based on certain parameters and present them in the bill in the ascending or descending order. It may also be used to sort data while generating various reports.

The **Bill Group Sorting** zone lists the sort IDs defined for all effective child persons whose person type is set to **Bill Group** and who are related to the parent customer using a relationship type which is specified in the **Person Relationship Type** option type of the **C1-ASOBLNG** feature configuration. It appears when you are viewing the 360° information of a person whose person type is set to **Parent Customer**.

You can define, edit, and delete a sort ID of a bill group (who is effective child person of the parent customer) through this zone. You can also upload a set of sort IDs for one or more bill groups (who are effective child persons of the parent customer) at the same time using the **Upload Request** feature. You can upload the sort IDs for bill groups either from this zone or from the **Upload Request** screen. While creating an upload request for bill group sort IDs, you need to specify the parent customer whose bill groups' sort IDs you want to upload. Once the upload request is processed, the sort ID is defined for the respective bill group in the system.

This zone contains the following columns:

Column Name	Column Description
Bill Group Information	Indicates the parent customer's bill group for whom the sort ID is defined. In addition, a context menu appears corresponding to this column which helps in navigating to other screens in the application.  <b>Note:</b> It has a link. On clicking the link, the <b>Person</b> screen appears where you can view the details of the respective bill group (i.e. person).
Bill Group ID	Displays the bill group ID (i.e. person ID).
Sort ID	Displays the sort ID.
Description	Displays the description of the sort ID.
Start Date	Displays the date from when the sort ID is effective for the bill group.
End Date	Displays the date till when the sort ID is effective for the bill group.

In addition, it contains the following buttons:

Button Name	Button Description
Edit	Used to edit the details of a bill group's sort ID.
Delete	Used to delete a bill group's sort ID.  <b>Note:</b> You can delete a bill group's sort ID only when the derivation and pricing parameters are not yet defined for the bill group and sort ID combination.

If you want to edit or delete all sort IDs of effective bill groups, you need to select the check box corresponding to the column header in this zone, and then accordingly click the **Edit** or **Delete** button. However, if you want to edit or delete

one or more sort IDs of effective bill groups, you need to select the check box corresponding to the bill group and sort ID combination, and then accordingly click the **Edit** or **Delete** button.

**Note:**

Pagination is used to display limited number of records in this zone. You can use the navigation links, such as **Previous** and **Next** to navigate between pages.

If you select the check box corresponding to the column header in this zone, the system considers only those records which are present on the respective page for editing or deleting.

You can define a sort ID for a bill group (who is effective child person of the parent customer) by clicking the **Add** link in the upper right corner of this zone. You can also upload a set of sort IDs for one or more bill groups (who are effective child persons of the parent customer) by clicking the **Upload** link in the upper right corner of this zone.

You can filter the list using the **Bill Group Name** field available in the **Filter** area. By default, the **Filter** area is hidden.

You can view the **Filter** area by clicking the **Filters** (  ) icon in the upper right corner of this zone.

You can change the layout of this zone. For more information on how to change the layout, see [Changing the Layout](#) on page 2882.

### Related Topics

For more information on...	See...
How to define a sort ID for a bill group	<a href="#">Defining a Sort ID for a Bill Group</a> on page 247
How to edit a sort ID of a bill group	<a href="#">Editing a Sort ID of a Bill Group</a> on page 248
How to delete a sort ID of a bill group	<a href="#">Deleting a Sort ID of a Bill Group</a> on page 249
How to create an upload request for bill group sort ID from the <b>Bill Group Sorting</b> zone	<a href="#">Creating a Bill Group Sorting Upload Request</a> on page 250
How to create an upload request for bill group sort ID from the <b>Upload Request</b> screen	<a href="#">Creating an Upload Request</a> on page 1660
How to setup the <b>C1-ASOBLNG</b> feature configuration	<a href="#">Setting the C1-ASOBLNG Feature Configuration</a> on page 2889

### Customer Contacts

The **Customer Contacts** zone displays information about how and when the person was contacted. It contains the following columns:

Column Name	Column Description
Contact Date	Displays the date when the person was contacted.
Customer Contact Information	Displays information about the customer contact.  <b>Note:</b> It has a link. On clicking the link, the <b>Customer Contact</b> screen appears where you can view the details of the customer contact.
Contact Type	Indicates how the person was contacted.
Comments	Displays additional information about the customer contact.

You can filter the list using various search criteria (such as, **On or Before Contact Date**, **Contact Class**, **Contact Type**, and **Show Open Contacts Only**) available in the **Filter** area. By default, the **Filter** area is hidden. You can view the **Filter** area by clicking the **Filters** (  ) icon in the upper right corner of this zone.

## Bill Groups Created Via Customer Registration

The **Bill Groups Created Via Customer Registration** zone lists the customer registration objects through which the parent customer's bill groups are created in the system. It appears when you are viewing the 360° information of a person whose person type is set to **Parent Customer**. It contains the following columns:

Column Name	Column Description
Customer Registration Information	Indicates the customer registration object through which the bill group is created.  <b>Note:</b> It has a link. On clicking the link, the <b>Customer Registration</b> screen appears where you can view the details of the respective customer registration object.
Person Name	Displays the name of the bill group.
Person Relationship Type	Indicates how the bill group is related to the parent customer.
Status	Indicates the status of the customer registration object. The valid value is: <ul style="list-style-type: none"> <li>• Bill Group Approved</li> </ul>

**Note:** Pagination is used to display limited number of records in this zone. You can use the navigation links, such as **Previous** and **Next** to navigate between pages.

You can filter the list using the **Person Relationship Type** field available in the **Filter** area. By default, the **Filter** area is hidden. You can view the **Filter** area by clicking the **Filters** (  ) icon in the upper right corner of this zone.

## Customer 360° Information - Account

The following table provides information about the **Account** tab:

If you are viewing the 360° information of...	Then...
A parent customer who is associated with the self-funded or fully-insured group policy	The <b>Account</b> tab displays the following: <ul style="list-style-type: none"> <li>• List of the parent customer's and bill groups' accounts. Note that the system lists the accounts of all effective child persons whose person type is set to <b>Bill Group</b> and who are related to the parent customer using a relationship type which is specified in the <b>Person Relationship Type</b> option type of the <b>C1-ASOBLNG</b> feature configuration.</li> <li>• Basic details, characteristics, automatic payment options, financial and collections summary, and unpaid bills of the parent customer's or bill group's account.</li> </ul>
A bill group who is associated with the self-funded or fully insured group policy	The <b>Account</b> tab displays the basic details, characteristics, automatic payment options, financial and collections summary, and unpaid bills of the bill group's account.  <b>Note:</b> If the bill group has multiple accounts, the system, by default, picks and displays the details of any one of its account.

If you are viewing the 360° information of...	Then...
A person whose person type is neither <b>Parent Customer</b> nor <b>Bill Group</b>	<p>The <b>Account</b> tab displays the basic details, characteristics, automatic payment options, administrative contracts, financial and collections summary, billing and adjustment summary, and unpaid bills of the person's account.</p> <div style="border: 1px solid black; padding: 5px; margin-top: 10px;"> <p><b>Note:</b> If the person has multiple accounts, the system, by default, picks and displays the details of any one of its account.</p> </div>

It contains the following zones:

- [Account List](#) on page 213

**Note:** The **Account List** zone appears when you are viewing the 360° information of a person whose person type is set to **Parent Customer**.

- [Account Information](#) on page 214
- [Auto Pay Details](#) on page 217
- [Account Characteristics](#) on page 216
- [Administrative Contracts](#) on page 216

**Note:** The **Administrative Contracts** zone appears when you are viewing the 360° information of a person whose person type is neither **Parent Customer** nor **Bill Group**.

- [Account Financial and Collections Summary](#) on page 217
- [Billing and Adjustment Summary](#) on page 218

**Note:** The **Billing and Adjustment Summary** zone appears when you are viewing the 360° information of a person whose person type is neither **Parent Customer** nor **Bill Group**.

- [Open Bills](#) on page 219
- [Billed Vs Paid](#) on page 220
- [Timeline](#) on page 223

### Related Topics

For more information on...	See...
How to view the 360° information of an account	<a href="#">Viewing the 360° Information of an Account</a> on page 190
How to setup the <b>C1-ASOBLNG</b> feature configuration	<a href="#">Setting the C1-ASOBLNG Feature Configuration</a> on page 2889

### Account List

The **Account List** zone lists the accounts of the parent customer and its bill groups. Note that the system lists the accounts of all effective child persons whose person type is set to **Bill Group** and who are related to the parent customer using a relationship type which is specified in the **Person Relationship Type** option type of the **C1-ASOBLNG** feature configuration. It appears when you are viewing the 360° information of a person whose person type is set to **Parent Customer**. It contains the following columns:

Column Name	Column Description
Person Name	Indicates the person who is linked to the account.
Account Information	Displays information about the account. In addition, a context menu appears corresponding to this column which helps in navigating to other screens in the application.  <b>Note:</b> It has a link. On clicking the link, the <b>Account</b> screen appears where you can view the details of the respective account.
Person Type	Indicates the type of the person. The valid values are: <ul style="list-style-type: none"> <li>• Business</li> <li>• Bill Group</li> <li>• Group</li> <li>• Broker</li> <li>• Person</li> <li>• Parent Customer</li> </ul>
Person's Mailing Address	Displays the mailing address of the person.
Person ID	Displays the person ID.

**Note:** Pagination is used to display limited number of records in this zone. You can use the navigation links, such as **Previous** and **Next** to navigate between pages.

On clicking the **Broadcast**  icon corresponding to an account, the following zones appear in the **Account** tab:

- Account Information
- Auto Pay Details
- Account Financial and Collections Summary
- Account Characteristics
- Open Bills
- Billed Vs Paid
- Timeline

You can filter the list using various search criteria (such as, **Person Name**, **Account ID**, and **Person Type**) available in the **Filter** area. By default, the **Filter** area is hidden. You can view the **Filter** area by clicking the **Filters**  icon in the upper right corner of this zone.

### **Related Topics**

For more information on...	See...
How to setup the <b>C1-ASOBLNG</b> feature configuration	<a href="#">Setting the C1-ASOBLNG Feature Configuration</a> on page 2889

### **Account Information**

The **Account Information** zone displays the details of the account. It contains the following sections:

- **Main** – Displays the basic information about the account. It contains the following fields:

Field Name	Field Description
Account Information	<p>Displays information about the account. In addition, a context menu appears corresponding to this field which helps in navigating to other screens in the application.</p> <p><b>Note:</b> It has a link. On clicking the link, the <b>Account</b> screen appears where you can view the details of the respective account.</p>
Management Group	<p>Indicates the account management group to which the account belongs.</p> <p><b>Note:</b></p> <p>It has a link. On clicking the link, the <b>Account Management Group</b> screen appears where you can view the details of the respective account management group.</p> <p>This field appears only when the respective data is available for the account.</p>

- **Contact Information** – Displays the contact details of the account’s main customer. It contains the following fields:

Field Name	Field Description
Address Source	Indicates which address should be used to route the account’s bills and/or quotes via the postal service.
Country	Indicates the country where the main customer is located.
Address 1	Displays the first line of the main customer’s address. It may contain details, such as house number and apartment name.
Address 2	Displays the second line of the main customer’s address. It may contain details, such as street name.
Address 3	Displays the third line of the main customer’s address. It may contain the landmark details.
Address 4	Displays the fourth line of the main customer’s address.
House Type	Indicates the type of the house.
Number 1	Displays the numeric information, if any, related to the address.
Number 2	Displays the numeric information, if any, related to the address.
In City Limit	<p>Indicates whether the main customer resides within the city limit or not. The valid values are:</p> <ul style="list-style-type: none"> <li>• Yes</li> <li>• No</li> </ul>
City	Displays the city where the main customer is located.
Geographic Code	Displays the geographic code of the address.
County	Displays the county where the main customer is located.
State	Indicates the state where the city or county is located.
Postal	Displays the postal or zip code of the address.

**Note:** The above mentioned fields except **Address Source** appear in the **Contact Information** section only when the address source of the main customer is set to **Account Override** and the respective data is available for the account.

- **Account Identifiers** – Lists various types of identification associated with the account. It contains the following columns:

Column Name	Column Description
Account Identifier Type	Indicates the account identifier type.
Account Identifier	Displays the value of the account identifier type.

### Account Characteristics

The **Account Characteristics** zone lists the characteristics defined for the account. It contains the following columns:

Column Name	Column Description
Effective Date	Displays the date from when the characteristic is effective for the account.
Characteristic Type	Indicates the characteristic type.
Characteristic Value	Displays the value of the characteristic type.
Description	Displays the description of the characteristic value.  <b>Note:</b> The data appears in this column only when the type of characteristic value is set to <b>Predefined Value</b> or <b>Foreign Key Value</b> .

You can filter the list using the **Characteristic Type** field available in the **Filter** area. By default, the **Filter** area is hidden. You can view the **Filter** area by clicking the **Filters** (  ) icon in the upper right corner of this zone.

### Administrative Contracts

The **Administrative Contracts** zone lists the account's contracts which should be monitored closely for various administrative reasons. It appears when you are viewing the 360° information of a person whose person type is neither **Parent Customer** nor **Bill Group**. It contains the following columns:

Column Name	Column Description
Contract ID	Displays the contract ID.  <b>Note:</b> It has a link. On clicking the link, the <b>Contract</b> screen appears where you can view the details of the respective contract.
Contract Type	Indicates the type of the contract.
Currency	Indicates the currency in which the contract balance is maintained.
Current Balance	Displays the current balance on the contract.

**Note:**

Pagination is used to display limited number of records in this zone. You can use the navigation links, such as **Previous** and **Next** to navigate between pages.

The data appears in this zone only when you have defined the value for the **Administrative Contract Type** option type in the **C1\_CMO** feature configuration.



**Related Topics**

For more information on...	See...
How to setup the C1_CMO feature configuration	<a href="#">Setting the C1_CMO Feature Configuration</a> on page 2906

**Auto Pay Details**

The **Auto Pay Details** zone lists the automatic payment options defined for the account. It contains the following columns:

Column Name	Column Description
Start Date	Displays the date from when the automatic payment option is effective.
End Date	Displays the date till when the automatic payment option is effective.
Auto Pay Source Code	Indicates the source of funds used to make the automatic payment. For example, debit or credit card.
Last Four Digits of Card	Displays the last four digits of the debit or credit card.  <b>Note:</b> The data appears in this column only when the external type of the auto pay source code's tender type is set to <b>Credit Card Withdrawal</b> .
Percentage	Indicates the percentage of automatic payment that must be made through the automatic payment option.
Priority	Indicates the order in which the automatic payment option should be considered for the effective date range.

**Note:** Pagination is used to display limited number of records in this zone. You can use the navigation links, such as **Previous** and **Next** to navigate between pages.

**Account Financial and Collections Summary**

The **Account Financial and Collections Summary** zone displays the financial and collection details of the account. It contains the following fields:

Field Name	Field Description
Collection Class	Indicates the collection class to which the account belongs.
Current Credit Rating	Indicates the account's credit rating which is effective on the current date.
Last Credit Review Date	Displays the date when the account's debt was last reviewed.
Last Payment Date	Displays the date when the last payment was made for the account.  <b>Note:</b> The system considers the last payment which is in the <b>Frozen</b> status.
Last Payment Amount	Displays the amount of the last payment.  <b>Note:</b> The system considers the last payment which is in the <b>Frozen</b> status.
Current Balance	Displays the current balance of the account.
Payoff Balance	Displays the payoff balance of the account.

Field Name	Field Description
Account on Hold	Indicates whether the account is on hold or not. The valid values are: <ul style="list-style-type: none"> <li>• Yes</li> <li>• No</li> </ul>
Account on Promise to Pay	Indicates whether any promise to pay is scheduled for the account on the current or future date. The valid values are: <ul style="list-style-type: none"> <li>• Yes</li> <li>• No</li> </ul>
Account on Payment Arrangement	Indicates whether any payment arrangement exists for the account. The valid values are: <ul style="list-style-type: none"> <li>• Yes</li> <li>• No</li> </ul>
Account on Payment Agreement	Indicates whether any active payment agreement request exists for the account. The valid values are: <ul style="list-style-type: none"> <li>• Yes</li> <li>• No</li> </ul>

### Billing and Adjustment Summary

The **Billing and Adjustment Summary** zone displays the billing and adjustment summary of the account. It appears when you are viewing the 360° information of a person whose person type is neither **Parent Customer** nor **Bill Group**. It contains the following sections:

- **Quote Billed Balance** – Displays information about the account’s billed balance. It contains the following fields:

Field Name	Field Description
Past Due Billed Balance	Displays the sum of open financial transactions of the account that are listed on a bill with a past due date.
Future Due Billed Balance	Displays the sum of open financial transactions of the account that are listed on a bill with a future due date.
Quote Billed Balance	Displays the sum of past due billed balance and future due billed balance.

- **Future Adjustments and Retroactivity** – Displays information about the account’s future adjustments and retro activities. It contains the following fields:

Field Name	Field Description
Future Adjustments	Displays the sum of adjustment financial transactions of the account which are swept onto the next bill.
Future Retro Terms (Credits)	Displays the sum of canceled bill segment financial transactions of the account which are presented on the next bill.

Field Name	Field Description
Future Retro Adds (Debits)	<p>Displays the sum of membership premium billable charges which are not yet billed to the account.</p> <p><b>Note:</b> The data appears in this field only when the values are defined for the <b>Premium Amount SQI</b> and <b>Coverage End Date SQI</b> option types in the <b>C1-BILLADJSQ</b> feature configuration.</p>
Future Balance with Adjustments & Debits/Credits	Displays the sum of quote billed balance, future adjustments, future retro terms (credits), and future retro adds (debits).

### Related Topics

For more information on...	See...
How to setup the <b>C1-BILLADJSQ</b> feature configuration	<a href="#">Setting the C1-BILLADJSQ Feature Configuration</a> on page 2904

### Open Bills

The **Open Bills** zone lists the unpaid bills of the account. By default, the bills where the unpaid amount is greater than zero are listed in this zone. It contains the following columns:

Column Name	Column Description										
Bill Date	<p>Displays the date when the bill was generated.</p> <p><b>Note:</b> The data in this column is presented in a different color depending on the age bucket in which the bill's days past due falls. The following table lists the color used for presentation in various age buckets:</p> <table border="1"> <thead> <tr> <th>Age Bucket</th> <th>Color</th> </tr> </thead> <tbody> <tr> <td>Age 0 to 30 DPD</td> <td>Black</td> </tr> <tr> <td>Age 31 to 60 DPD</td> <td>Green</td> </tr> <tr> <td>Age 61 to 90 DPD</td> <td>Orange</td> </tr> <tr> <td>Age &gt; 90 DPD</td> <td>Red</td> </tr> </tbody> </table>	Age Bucket	Color	Age 0 to 30 DPD	Black	Age 31 to 60 DPD	Green	Age 61 to 90 DPD	Orange	Age > 90 DPD	Red
Age Bucket	Color										
Age 0 to 30 DPD	Black										
Age 31 to 60 DPD	Green										
Age 61 to 90 DPD	Orange										
Age > 90 DPD	Red										
Bill ID	<p>Displays the bill ID.</p> <p><b>Note:</b> It has a link. On clicking the link, the <b>Bill</b> screen appears where you can view the details of the respective bill.</p>										
Due Date	Displays the date when the bill is due for payment.										
Bill Amount	Displays the bill amount.										
Bill Status	<p>Indicates the status of the bill. The valid values are:</p> <ul style="list-style-type: none"> <li>• Pending</li> <li>• Complete</li> </ul>										
Unpaid Amount	Displays the unpaid amount of the bill.										

Column Name	Column Description
Age Bucket	Indicates the age bucket in which the bill's days past due falls. The valid values are: <ul style="list-style-type: none"> <li>• Age 0 to 30 DPD</li> <li>• Age 31 to 60 DPD</li> <li>• Age 61 to 90 DPD</li> <li>• Age &gt; 90 DPD</li> </ul>
Days Past Due	Displays the number of days past after the due date.
Overdue Process Information	Indicates the overdue process which is initiated for the bill and is currently in the <b>Active</b> status. In addition, this column has a context menu which helps in navigating to other screens in the application. <div style="border: 1px solid black; padding: 5px; margin-top: 10px;"> <p><b>Note:</b> It has a link. On clicking the link, the <b>Overdue Process</b> screen appears where you can view the details of the respective overdue process.</p> </div>
Payment Agreement Request Information	Indicates the active payment agreement request in which the bill is included. <div style="border: 1px solid black; padding: 5px; margin-top: 10px;"> <p><b>Note:</b> It has a link. On clicking the link, the <b>Payment Agreement Request</b> screen appears where you can view the details of the respective payment agreement request.</p> </div>

You can view additional information about the bill by clicking the **View** () icon corresponding to the bill in the **Open Bills** zone.

You can filter the list using various search criteria (such as, **On or Before Bill Date** and **Show All Bills**) available in the **Filter** area. By default, the **Filter** area is hidden. You can view the **Filter** area by clicking the **Filters** () icon in the upper right corner of this zone.

**Note:** If you select the **Show All Bills** option, the system lists all bills where the unpaid amount is greater than or equal to zero.

### Related Topics

For more information on...	See...
How to view the details of a bill	<a href="#">Viewing the Bill Details</a> on page 262

### **Billed Vs Paid**

The **Billed Vs Paid** zone lists the following transactions of the account:

- Bills which are created for the account
- Any excess credit which is made for the account
- Payments which are created or canceled for the account
- Adjustments which are created or canceled for the account
- Refund or Write Off adjustments which are created or canceled for the account
- Payment transfer to the reconciliation contract of the account
- Payment transfer from the reconciliation contract to the payor account's contract
- Reconciliations through which the account's bill segments are reconciled

- Automatic payments sent to the auto clearing house for review before freezing them

**Note:** The excess credit information for the account appears only when you have defined the value for the **On Account Contract Type** option type in the **C1\_CMO** feature configuration. Accordingly, the excess credit information (if any) on the respective contracts is listed in this zone.

It contains the following columns:

Column Name	Column Description																						
Due Date	<p>Displays the date when the bill is due for payment.</p> <p><b>Note:</b> The data appears in this column only when the transaction type is set to <b>Bill</b>.</p>																						
Bill ID	<p>Displays the bill ID.</p> <p><b>Note:</b> It has a link. On clicking the link, the <b>Bill</b> screen appears where you can view the details of the respective bill. The data appears in this column only when the transaction type is set to <b>Bill</b>.</p>																						
Transaction Date	<p>The following table indicates the date that appears depending on the type of the transaction:</p> <table border="1"> <thead> <tr> <th>If the transaction type is...</th> <th>Then...</th> </tr> </thead> <tbody> <tr> <td>Bill</td> <td>Date when the bill is generated for the account</td> </tr> <tr> <td>Payment</td> <td>Date when the payment is made for the account</td> </tr> <tr> <td>Adjustment</td> <td>Date when the adjustment is created for the account</td> </tr> <tr> <td>Payment Cancellation</td> <td>Date when the payment is canceled for the account</td> </tr> <tr> <td>Adjustment Cancellation</td> <td>Date when the adjustment is canceled for the account</td> </tr> <tr> <td>Excess Credit (overpayment)</td> <td>Date when the excess credit is made for the account</td> </tr> <tr> <td>Reconciliation Contract</td> <td>Date when the payment is transferred to the reconciliation contract of the account</td> </tr> <tr> <td>Reconciliation Contract - Returned</td> <td>Date when the payment made to the reconciliation contract of the account is canceled</td> </tr> <tr> <td>Payment Transfer</td> <td>Date when the pay instruction for the account is reconciled</td> </tr> <tr> <td>Payment Transfer Cancellation</td> <td>Date when the reconciliation is canceled</td> </tr> </tbody> </table> <p><b>Note:</b> The data does not appear in this column for automatic payments which are sent to the auto clearing house for review.</p>	If the transaction type is...	Then...	Bill	Date when the bill is generated for the account	Payment	Date when the payment is made for the account	Adjustment	Date when the adjustment is created for the account	Payment Cancellation	Date when the payment is canceled for the account	Adjustment Cancellation	Date when the adjustment is canceled for the account	Excess Credit (overpayment)	Date when the excess credit is made for the account	Reconciliation Contract	Date when the payment is transferred to the reconciliation contract of the account	Reconciliation Contract - Returned	Date when the payment made to the reconciliation contract of the account is canceled	Payment Transfer	Date when the pay instruction for the account is reconciled	Payment Transfer Cancellation	Date when the reconciliation is canceled
If the transaction type is...	Then...																						
Bill	Date when the bill is generated for the account																						
Payment	Date when the payment is made for the account																						
Adjustment	Date when the adjustment is created for the account																						
Payment Cancellation	Date when the payment is canceled for the account																						
Adjustment Cancellation	Date when the adjustment is canceled for the account																						
Excess Credit (overpayment)	Date when the excess credit is made for the account																						
Reconciliation Contract	Date when the payment is transferred to the reconciliation contract of the account																						
Reconciliation Contract - Returned	Date when the payment made to the reconciliation contract of the account is canceled																						
Payment Transfer	Date when the pay instruction for the account is reconciled																						
Payment Transfer Cancellation	Date when the reconciliation is canceled																						

Column Name	Column Description
Transaction Type	<p>Indicates the type of the transaction. The valid values are:</p> <ul style="list-style-type: none"> <li>• Bill</li> <li>• Payment</li> <li>• Adjustment</li> <li>• Payment Cancellation</li> <li>• Adjustment Cancellation</li> <li>• Excess Credit (overpayment)</li> <li>• Reconciliation Contract</li> <li>• Reconciliation Contract - Returned</li> <li>• Payment Transfer</li> <li>• Payment Transfer Cancellation</li> </ul>
Transaction Description	<p>Displays the description of the transaction.</p> <p><b>Note:</b> The data appears in this column only when the transaction type is set to <b>Adjustment, Adjustment Cancellation, Reconciliation Contract - Returned, Payment Transfer, and Payment Transfer Cancellation</b>. In addition, the data appears in this column when the automatic payments are sent to the auto clearing house for review before freezing them. The transaction description for such payments is set to <b>Pending Payment</b>.</p>
Transaction Amount	Displays the transaction amount.
Unpaid Amount	<p>Displays the unpaid amount of the bill.</p> <p><b>Note:</b> The data appears in this column only when the transaction type is set to <b>Bill</b>.</p>
Payment Date	<p>Displays the date when the payment is created or canceled for the account.</p> <p><b>Note:</b> The data appears in this column only when the transaction type is set to <b>Payment, Payment Cancellation, or Excess Credit (overpayment)</b>.</p>
Tender Type	Indicates the type of tender through which the payment was made.
Check Number/External Reference ID	Displays the check number or external reference ID.
Transaction ID	<p>Displays the payment, adjustment, or reconciliation ID.</p> <p><b>Note:</b> It has a link. On clicking the link, the <b>Payment, Adjustment, or Reconciliation</b> screen appears where you can view the details of the respective transaction.</p>

You can filter the list using the **On or Before Due Date** field available in the **Filter** area. By default, the **Filter** area is hidden. You can view the **Filter** area by clicking the **Filters** (  ) icon in the upper right corner of this zone.

You can change the layout of this zone. For more information on how to change the layout, see [Changing the Layout](#) on page 2882.

### **Related Topics**

<b>For more information on...</b>	<b>See...</b>
How to setup the <b>C1_CMO</b> feature configuration	<a href="#">Setting the C1_CMO Feature Configuration</a> on page 2906

## Timeline





The **Timeline** zone displays the following information in a graphical form:

- Number of customer contacts which are created for the account's main customer in a particular month
- Number of bills which are created for the account in a particular month
- Number of payments which are created for the account in a particular month

It contains the following fields:

Field Name	Field Description	Mandatory (Yes or No)
Month	Used to indicate the month till when you want to display the above stated information.  <b>Note:</b> By default, the current month appears in this field.	Yes
Year	Used to indicate the year till when you want to display the above stated information.  <b>Note:</b> By default, the current year appears in this field.	Yes

Depending on the month and year specified in the above fields, the data for the respective month and previous 11 months is presented in the grid. For example, if the Month and Year is set to April 2017, then the data for the May 2016, Jun 2016, Jul 2016, Aug 2016, Sep 2016, Oct 2016, Nov 2016, Dec 2016, Jan 2017, Feb 2017, Mar 2017, and Apr 2017 appears in the grid. To view the data for a different period, you must accordingly change the month and year and then click **Search** () icon.

You can use the **Previous 12 Months** () , **Previous Month** () , **Go To Today** () , **Next Month** () , and **Next 12 Months** () icons to change the values specified in the above mentioned fields.

The following table indicates the data and the manner in which the data is presented in the grid:

Row Name	Row Description										
Customer Contacts	<p>A small icon appears for each customer contact which is created for the account's main customer in the respective month. For example, if two customer contacts are created for the main customer in the month of Jan 2017 and one customer contact is created in the month of Feb 2017, then two icons appear in the Jan 2017 column and one icon appear in the Feb 2017 column. A text indicating the day of the month when the customer contact was created appears on the icon. The following table indicates the color in which the icon appears depending on the condition which is satisfied:</p> <table border="1" data-bbox="467 453 1461 636"> <thead> <tr> <th data-bbox="475 459 964 531">If the contact action on the customer contact type is...</th> <th data-bbox="972 459 1453 531">Then the icon appears in...</th> </tr> </thead> <tbody> <tr> <td data-bbox="475 533 964 583">Set to <b>Send Letter</b></td> <td data-bbox="972 533 1453 583">Red</td> </tr> <tr> <td data-bbox="475 585 964 636">Set to <b>Action Algorithm</b></td> <td data-bbox="972 585 1453 636">Yellow</td> </tr> </tbody> </table> <p>On clicking the icon, the corresponding customer contact information appears at the bottom of this zone. It has a link. On clicking the link, the <b>Customer Contact</b> screen appears where you can view the details of the respective customer contact.</p> <p><b>Note:</b> You can change the color in which the text appears on the icon and the color in which the icon appears when the above stated conditions are met through the <b>C1-TL-CC-EVT</b> algorithm.</p>	If the contact action on the customer contact type is...	Then the icon appears in...	Set to <b>Send Letter</b>	Red	Set to <b>Action Algorithm</b>	Yellow				
If the contact action on the customer contact type is...	Then the icon appears in...										
Set to <b>Send Letter</b>	Red										
Set to <b>Action Algorithm</b>	Yellow										
Bills	<p>A small icon appears for each bill which is created for the account in the respective month. For example, if three bills are created for the account in the month of Jan 2017, two bills are created in the month of Feb 2017, and one bill is created in the month of Apr 2017, then three icons appear in the Jan 2017 column, two icons appear in the Feb 2017 column, and one icon appears in the Apr 2017 column. A text indicating the day of the month when the bill was due appears on the icon. You can either display the day of the due date or bill date on the icon depending on the requirement. The following table indicates the color in which the icon appears depending on the condition which is satisfied:</p> <table border="1" data-bbox="467 1155 1461 1404"> <thead> <tr> <th data-bbox="475 1161 964 1203">If the bill is...</th> <th data-bbox="972 1161 1453 1203">Then the icon appears in...</th> </tr> </thead> <tbody> <tr> <td data-bbox="475 1205 964 1255">Fully Matched</td> <td data-bbox="972 1205 1453 1255">Green</td> </tr> <tr> <td data-bbox="475 1257 964 1308">Unmatched</td> <td data-bbox="972 1257 1453 1308">Red</td> </tr> <tr> <td data-bbox="475 1310 964 1360">Credit Note</td> <td data-bbox="972 1310 1453 1360">Blue</td> </tr> <tr> <td data-bbox="475 1362 964 1404">Scheduled for billing in the next bill cycle</td> <td data-bbox="972 1362 1453 1404">Black</td> </tr> </tbody> </table> <p>On clicking the icon, the corresponding bill information appears at the bottom of this zone. It has a link. On clicking the link, the <b>Bill</b> screen appears where you can view the details of the respective bill.</p> <p><b>Note:</b></p> <p>If you want to display the day of the due date on the icon, you must set the <b>Date To Use (D-Due Date, B-Bill Date)</b> parameter in the <b>C1-TL-OI-EVT</b> algorithm to <b>D</b>. However, if you want to display the day of the bill date on the icon, you must set the <b>Date To Use (D-Due Date, B-Bill Date)</b> parameter in the <b>C1-TL-OI-EVT</b> algorithm to <b>B</b>.</p> <p>You can change the color in which the text appears on the icon and the color in which the icon appears when the above stated conditions are met through the <b>C1-TL-OI-EVT</b> algorithm.</p>	If the bill is...	Then the icon appears in...	Fully Matched	Green	Unmatched	Red	Credit Note	Blue	Scheduled for billing in the next bill cycle	Black
If the bill is...	Then the icon appears in...										
Fully Matched	Green										
Unmatched	Red										
Credit Note	Blue										
Scheduled for billing in the next bill cycle	Black										



Row Name	Row Description												
Payments	<p>A small icon appears for each payment which is created for the account in the respective month. For example, if one payment is created for the account in the month of Aug 2016, three payments are created in the month of Dec 2016, and four payments are created in the month of Mar 2017, then one icon appears in the Aug 2016 column, three icons appear in the Dec 2016 column, and four icons appear in the Mar 2017 column. A text indicating the day of the month when the payment was created appears on the icon. The following table indicates the color in which the icon appears depending on the status of the payment:</p> <table border="1"> <thead> <tr> <th>Status</th> <th>Color</th> </tr> </thead> <tbody> <tr> <td>Frozen</td> <td>Green</td> </tr> <tr> <td>Canceled</td> <td>Red</td> </tr> <tr> <td>Freezable</td> <td>Blue</td> </tr> <tr> <td>Error</td> <td>Red</td> </tr> <tr> <td>Incomplete</td> <td>Yellow</td> </tr> </tbody> </table> <p>On clicking the icon, the corresponding payment information appears at the bottom of this zone. It has a link. On clicking the link, the <b>Payment</b> screen appears where you can view the details of the respective payment.</p> <p><b>Note:</b> You can change the color in which the text appears on the icon and the color in which the icon appears in the different status through the <b>C1-TL-PY-EVT</b> algorithm.</p>	Status	Color	Frozen	Green	Canceled	Red	Freezable	Blue	Error	Red	Incomplete	Yellow
Status	Color												
Frozen	Green												
Canceled	Red												
Freezable	Blue												
Error	Red												
Incomplete	Yellow												

## Customer 360° Information - Policy

The following table provides information about the **Policy** tab:

If you are viewing the 360° information of...	Then...
A parent customer who is associated with the self-funded policy	<p>The <b>Policy</b> tab displays the following:</p> <ul style="list-style-type: none"> <li>List of self-funded policies to which the parent customer's bill groups are associated.</li> </ul> <p><b>Note:</b> The system lists only those policies of the bill groups where the parent customer is associated as a policy holder.</p> <ul style="list-style-type: none"> <li>Basic details and policy persons of a self-funded policy where the parent customer is the policy holder.</li> </ul>
A parent customer who is associated with the fully-insured group policy	<p>The <b>Policy</b> tab displays the following:</p> <ul style="list-style-type: none"> <li>List of fully-insured group policies to which the parent customer or its bill groups are associated.</li> </ul> <p><b>Note:</b> The system lists only those policies of the bill groups where the parent customer is associated as a policy holder.</p> <ul style="list-style-type: none"> <li>Basic details, policy persons, and policy plans of a fully-insured group policy to which the parent customer or its bill group is associated.</li> </ul>

If you are viewing the 360° information of...	Then...
A bill group who is associated with the self-funded policy	The <b>Policy</b> tab displays the following: <ul style="list-style-type: none"> <li>List of self-funded policies to which the bill group is associated.</li> <li>Basic details and policy persons of a self-funded policy.</li> </ul>
A bill group who is associated with the fully-insured group policy	The <b>Policy</b> tab displays the following: <ul style="list-style-type: none"> <li>List of fully-insured group policies to which the bill group is associated.</li> <li>Basic details, policy persons, and policy plans of a fully-insured group policy.</li> </ul>
A person whose person type is neither <b>Parent Customer</b> nor <b>Bill Group</b>	The <b>Policy</b> tab displays the following: <ul style="list-style-type: none"> <li>List of self-funded or fully-insured group policies to which the person is associated.</li> <li>Basic details, policy persons, and policy plans of a self-funded or fully-insured group policy.</li> </ul>

It contains the following zones:

- [Policy List](#) on page 226

**Note:** The **Policy List** zone appears when there is more than one policy associated with the person.

- [Policy Information](#) on page 227
- [Policy Persons](#) on page 228
- [Policy Plans](#) on page 228

**Note:** The **Policy Plans** zone appears when you are viewing the 360° information of a person who is associated with the fully-insured group policy.

### Related Topics

For more information on...	See...
How to view the 360° information of a policy	<a href="#">Viewing the 360° Information of a Policy</a> on page 191

### Policy List

If you are viewing 360° information of a parent customer, the **Policy List** zone lists the policies to which the parent customer and its bill groups are associated. Note that the system lists the policies of all effective child persons whose person type is set to **Bill Group** and who are related to the parent customer using a relationship type which is specified in the **Person Relationship Type** option type of the **C1-ASOBLNG** feature configuration.

**Note:** The system lists only those policies of the bill groups where the parent customer is associated as a policy holder.

If you are viewing 360° information of a bill group, the **Policy List** zone lists the policies to which the bill group is associated. If you are viewing 360° information of a person who is neither a parent customer nor a bill group, the **Policy List** zone lists the policies to which the person is associated. This zone appears when there is more than one policy associated with the person. It contains the following columns:

Column Name	Column Description
Policy Number	Displays the policy number.
Policy Information	Displays information about the policy. <b>Note:</b> It has a link. On clicking the link, the <b>Policy</b> screen appears where you can view the details of the respective policy.
Policy Type	Indicates the type of the policy.
Status	Indicates the status of the policy.
Start Date	Displays the date from when the policy is effective.
End Date	Displays the date till when the policy is effective.

**Note:** Pagination is used to display limited number of records in this zone. You can use the navigation links, such as **Previous** and **Next** to navigate between pages.

On clicking the **Broadcast**  icon corresponding to a policy, the following zones appear in the **Policy** tab:

- Policy Information
- Policy Persons
- Policy Plans

You can filter the list using various search criteria (such as, **Policy Number**, **Start Date**, **Policy Type**, **End Date**, and **Status**) available in the **Filter** area. By default, the **Filter** area is hidden. You can view the **Filter** area by clicking the **Filters**  icon in the upper right corner of this zone.

#### Related Topics

For more information on...	See...
How to setup the <b>C1-ASOBLNG</b> feature configuration	<a href="#">Setting the C1-ASOBLNG Feature Configuration</a> on page 2889

#### **Policy Information**

The **Policy Information** zone displays the details of the policy. It contains the following sections:

- **Main** – Displays the basic information about the policy. It contains the following fields:

Field Name	Field Description
Policy Information	Displays information about the policy. <b>Note:</b> It has a link. On clicking the link, the <b>Policy</b> screen appears where you can view the details of the respective policy.
Source System	Displays the name of the external system in which the policy is created.
Policy Number	Displays the policy number.
Status	Indicates the status of the policy.
Start Date	Displays the date from when the policy is effective.
End Date	Displays the date till when the policy is effective.

Field Name	Field Description
Runout End Date	Displays the date when the runout period of the policy ends.  <b>Note:</b> This field appears only when you are viewing the 360° information of a person who is associated with a self-funded policy.
Runout Administration Fees	Indicates whether the administration fees must be charged when the claim transaction for the policy is processed in the runout period. The valid values are: <ul style="list-style-type: none"> <li>• None</li> <li>• Percentage of Claim</li> </ul> <b>Note:</b> This field appears only when you are viewing the 360° information of a person who is associated with a self-funded policy. At present, this field is used only for the information purposes and is not considered during the billable charge creation for the claim transactions which are received in the runout period of the policy.

- **Characteristics** – Lists the characteristics defined for the policy. It contains the following columns:

Column Name	Column Description
Effective Date	Displays the date from when the characteristic is effective for the policy.
Characteristic Type	Indicates the characteristic type.
Characteristic Value	Displays the value of the characteristic type.

### Policy Persons

The **Policy Persons** zone lists the persons associated with the policy. It contains the following columns:

Column Name	Column Description
Person Name	Indicates the person who is associated with the policy.
Policy Person Role	Indicates the role of the person with respect to the policy.
Start Date	Displays the date from when the person is associated with the policy.
End Date	Displays the date till when the person is associated with the policy.

**Note:** Pagination is used to display limited number of records in this zone. You can use the navigation links, such as **Previous** and **Next** to navigate between pages.

You can view the 360° information of a policy person by clicking the **View** () icon corresponding to the person in the **Policy Persons** zone.

### Policy Plans

The **Policy Plans** zone lists the plans defined in the policy. It appears when you are viewing the 360° information of a person who is associated with the fully-insured group policy. It contains the following columns:

Column Name	Column Description
Policy Plan Information	Displays information about the policy plan. In addition, this column has a context menu which helps in navigating to other screens in the application.  <b>Note:</b> It has a link. On clicking the link, the <b>Policy Plan</b> screen appears where you can view the details of the respective policy plan.
Start Date	Displays the date from when the policy plan is effective.
End Date	Displays the date till when the policy plan is effective.
Plan	Indicates the price item associated with the policy plan.
Policy Plan Description	Displays the description of the price item.
No. of Subscribers	Indicates the number of main subscribers in the policy plan.
No. of Members	Indicates the number of members in the policy plan.

**Note:**

Pagination is used to display limited number of records in this zone. You can use the navigation links, such as **Previous** and **Next** to navigate between pages.

You can view the pricing rules defined for a policy plan by clicking the **View** () icon corresponding to the policy plan in the **Policy Plans** zone.

You can filter the list using various search criteria (such as, **Plan Start Date** and **Plan End Date**) available in the **Filter** area. By default, the **Filter** area is hidden. You can view the **Filter** area by clicking the **Filters** () icon in the upper right corner of this zone.

## Customer 360° Information - Pricing

The following table provides information about the **Pricing** tab:

If you are viewing the 360° information of...	Then...
A parent customer who is associated with the self-funded policy	<p>The <b>Pricing</b> tab displays the following:</p> <ul style="list-style-type: none"> <li>• Basic details of the pricing rules which are defined for the parent customer.</li> <li>• Summarized tree view listing each bill group of the parent customer and the bill groups' self-funded policies and pricing rules.</li> <li>• Basic details of the self-funded policies which are associated with each bill group of the parent customer.</li> <li>• Basic details of the pricing rules which are defined for the self-funded policies of each bill group.</li> <li>• Basic details of the active pricing groups which are defined for each bill group.</li> <li>• Basic information about the approval transactions which are created while defining, editing, and deleting the parent customer's and bill groups' pricing rules.</li> </ul>

If you are viewing the 360° information of...	Then...
A bill group who is associated with the self-funded policy	<p>The <b>Pricing</b> tab displays the following:</p> <ul style="list-style-type: none"> <li>• Summarized tree view listing the parent customer and pricing rules which are defined for the parent customer.</li> <li>• Basic details of the self-funded policies which are associated with the bill group.</li> <li>• Basic details of the pricing rules which are defined for the self-funded policies of the bill group.</li> <li>• Basic details of the active pricing groups which are defined for the bill group.</li> <li>• Basic information about the approval transactions which are created while defining, editing, and deleting the pricing rules of the bill group.</li> </ul>
A parent customer who is associated with the fully-insured group policy	<p>The <b>Pricing</b> tab displays the following:</p> <ul style="list-style-type: none"> <li>• Summarized tree view listing the fully-insured group policies of the parent customer and its bill group along with their respective policy plans and pricing rules.</li> <li>• Basic policy plan details of the fully-insured group policy to which the parent customer or its bill group is associated.</li> <li>• Basic details of the pricing rules which are defined for the fully-insured group policy plans.</li> <li>• Basic information about the approval transactions which are created while defining, editing, and deleting a pricing rule of a policy plan.</li> </ul>
A bill group who is associated with the fully-insured group policy	<p>The <b>Pricing</b> tab displays the following:</p> <ul style="list-style-type: none"> <li>• Summarized tree view listing the fully-insured group policies of the bill group along with their respective policy plans and pricing rules.</li> <li>• Basic policy plan details of the fully-insured group policy to which the bill group is associated.</li> <li>• Basic details of the pricing rules which are defined for the fully-insured group policy plans.</li> <li>• Basic information about the approval transactions which are created while defining, editing, and deleting a pricing rule of a policy plan.</li> </ul>
A person whose person type is neither <b>Parent Customer</b> nor <b>Bill Group</b>	No data appears in the <b>Pricing</b> tab.

It contains the following zones:

- [Parent Customer Pricing Rules](#) on page 231

**Note:** The **Parent Customer Pricing Rules** zone appears when you are viewing 360° information of a parent customer who is associated with the self-funded or fully-insured group policy.

- [Bill Group ASO Policy Pricing Rule Summary](#) on page 234

**Note:** The **Bill Group ASO Policy Pricing Rule Summary** zone appears when you are viewing 360° information of a parent customer who is associated with the self-funded policy.

- [Parent Customer Pricing Rule Summary](#) on page 235

**Note:** The **Parent Customer Pricing Rule Summary** zone appears when you are viewing 360° information of a bill group who is associated with the self-funded policy.

- [Bill Group ASO Policy Information](#) on page 236

**Note:** The **Bill Group ASO Policy Information** zone appears when you are viewing 360° information of a parent customer or bill group who is associated with the self-funded policy.

- [Bill Group ASO Policy Pricing Rules](#) on page 237

**Note:** The **Bill Group ASO Policy Pricing Rules** zone appears when you are viewing 360° information of a parent customer or bill group who is associated with the self-funded policy.

- [Policy Plan Pricing Rule Summary](#) on page 244

**Note:** The **Policy Plan Pricing Rule Summary** zone appears when you are viewing 360° information of a parent customer or bill group who is associated with the fully-insured group policy.

- [Policy Plan Information](#) on page 245

**Note:** The **Policy Plan Information** zone appears when you are viewing 360° information of a parent customer or bill group who is associated with the fully-insured group policy.

- [Policy Plan Pricing Rules](#) on page 246

**Note:** The **Policy Plan Pricing Rules** zone appears when you are viewing 360° information of a parent customer or bill group who is associated with the fully-insured group policy.

- [Bill Group Pricing Groups](#) on page 242

**Note:** The **Bill Group Pricing Groups** zone appears when you are viewing 360° information of a bill group who is associated with the self-funded policy.



- [Pricing Rule Approval Transactions](#) on page 243

### **Related Topics**

<b>For more information on...</b>	<b>See...</b>
How to view the pricing information of a parent customer	<a href="#">Viewing the Pricing Information of a Parent Customer</a> on page 192
How to view the pricing information of a bill group	<a href="#">Viewing the Pricing Information of a Bill Group</a> on page 194
How to setup the <b>C1-ASOBLLNG</b> feature configuration	<a href="#">Setting the C1-ASOBLLNG Feature Configuration</a> on page 2889

### **Parent Customer Pricing Rules**

The **Parent Customer Pricing Rules** zone lists the pricing rules which are defined for the parent customer. It appears when you are viewing 360° information of a parent customer who is associated with the self-funded or fully-insured group policy. It contains the following columns:

Column Name	Column Description																		
Pricing Rule Type	<p>Indicates the pricing rule type using which the pricing rule is created.</p> <p><b>Note:</b> It has a link. On clicking the link, the <b>Pricing Rule Type</b> screen appears where you can view the details of the respective pricing rule type.</p>																		
Pricing Rule Information	<p>Displays information about the pricing rule.</p> <p><b>Note:</b> It has a link. On clicking the link, the <b>Pricing Rule</b> screen appears where you can view the details of the respective pricing rule.</p>																		
Price Item Information	<p>Indicates the price item for which the pricing rule is created.</p> <p><b>Note:</b> It has a link. On clicking the link, the <b>Price Item</b> screen appears where you can view the details of the respective price item.</p>																		
Start Date	Displays the date from when the pricing rule is effective.																		
End Date	Displays the date till when the pricing rule is effective.																		
Status	<p>Indicates the status of the pricing rule. The valid values are:</p> <ul style="list-style-type: none"> <li>• Pending</li> <li>• Active</li> </ul>																		
Edit	<p>On clicking the <b>Edit</b> () icon, the following screen appears where you can edit the details of the respective pricing rule:</p> <table border="1"> <thead> <tr> <th>If you are editing...</th> <th>Then the following screen appears...</th> </tr> </thead> <tbody> <tr> <td>A claim pricing rule</td> <td>Claim Pricing Rule</td> </tr> <tr> <td>A specific stop-loss pricing rule</td> <td>Specific Stop-Loss (SSL) Pricing Rule</td> </tr> <tr> <td>An aggregate stop-loss pricing rule</td> <td>Aggregate Stop-Loss (ASL) Pricing Rule</td> </tr> <tr> <td>A retention type claim based pricing rule</td> <td>Retention Type Claim Based Pricing Rule</td> </tr> <tr> <td>A retention type enrollment based pricing rule</td> <td>Retention Type Enrollment Based Pricing Rule</td> </tr> <tr> <td>An ancillary pricing rule</td> <td>Ancillary Pricing Rule</td> </tr> <tr> <td>A discount arrangement pricing rule</td> <td>Discount Arrangement Pricing Rule</td> </tr> <tr> <td>A level funded pricing rule</td> <td>Level Funded (LF) Pricing Rule</td> </tr> </tbody> </table>	If you are editing...	Then the following screen appears...	A claim pricing rule	Claim Pricing Rule	A specific stop-loss pricing rule	Specific Stop-Loss (SSL) Pricing Rule	An aggregate stop-loss pricing rule	Aggregate Stop-Loss (ASL) Pricing Rule	A retention type claim based pricing rule	Retention Type Claim Based Pricing Rule	A retention type enrollment based pricing rule	Retention Type Enrollment Based Pricing Rule	An ancillary pricing rule	Ancillary Pricing Rule	A discount arrangement pricing rule	Discount Arrangement Pricing Rule	A level funded pricing rule	Level Funded (LF) Pricing Rule
If you are editing...	Then the following screen appears...																		
A claim pricing rule	Claim Pricing Rule																		
A specific stop-loss pricing rule	Specific Stop-Loss (SSL) Pricing Rule																		
An aggregate stop-loss pricing rule	Aggregate Stop-Loss (ASL) Pricing Rule																		
A retention type claim based pricing rule	Retention Type Claim Based Pricing Rule																		
A retention type enrollment based pricing rule	Retention Type Enrollment Based Pricing Rule																		
An ancillary pricing rule	Ancillary Pricing Rule																		
A discount arrangement pricing rule	Discount Arrangement Pricing Rule																		
A level funded pricing rule	Level Funded (LF) Pricing Rule																		
Delete	<p>On clicking the <b>Delete</b> () icon, you can delete the pricing rule.</p> <p><b>Note:</b> You can delete a pricing rule only when it is not yet used in the system.</p>																		
Price List Information	<p>Indicates the price list which contains the price item pricing which is created through the pricing rule.</p> <p><b>Note:</b> It has a link. On clicking the link, the <b>Price List</b> screen appears where you can view the details of the respective price list.</p>																		



**Note:** Pagination is used to display limited number of records in this zone. You can use the navigation links, such as **Previous** and **Next** to navigate between pages.

You can define a new pricing rule for the parent customer by clicking the **Add** link in the upper right corner of this zone.

You can filter the list using various search criteria (such as, **Price Item**, **Start Date**, **Pricing Rule Type**, **End Date**, and **Status**) available in the **Filter** area. By default, the **Filter** area is hidden. You can view the **Filter** area by clicking the **Filters** (  ) icon in the upper right corner of this zone.

You can change the layout of this zone. For more information on how to change the layout, see [Changing the Layout](#) on page 2882.

### Related Topics

For more information on...	See...
How to define a claim pricing rule for a parent customer	<a href="#">Defining a Claim Pricing Rule for a Parent Customer</a> on page 2365
How to edit a claim pricing rule of a parent customer	<a href="#">Editing a Claim Pricing Rule of a Parent Customer</a> on page 2372
How to delete a claim pricing rule of a parent customer	<a href="#">Deleting a Claim Pricing Rule of a Parent Customer</a> on page 2375
How to view the details of a claim pricing rule defined for a parent customer	<a href="#">Viewing a Claim Pricing Rule of a Parent Customer</a> on page 2374
How to define a specific stop-loss pricing rule for a parent customer	<a href="#">Defining a Specific Stop-Loss Pricing Rule for a Parent Customer</a> on page 2395
How to edit a specific stop-loss pricing rule of a parent customer	<a href="#">Editing a Specific Stop-Loss Pricing Rule of a Parent Customer</a> on page 2404
How to delete a specific stop-loss pricing rule of a parent customer	<a href="#">Deleting a Specific Stop-Loss Pricing Rule of a Parent Customer</a> on page 2407
How to view the details of a specific stop-loss pricing rule defined for a parent customer	<a href="#">Viewing a Specific Stop-Loss Pricing Rule of a Parent Customer</a> on page 2406
How to define an aggregate stop-loss pricing rule for a parent customer	<a href="#">Defining an Aggregate Stop-Loss Pricing Rule for a Parent Customer</a> on page 2431
How to edit an aggregate stop-loss pricing rule of a parent customer	<a href="#">Editing an Aggregate Stop-Loss Pricing Rule of a Parent Customer</a> on page 2439
How to delete an aggregate stop-loss pricing rule of a parent customer	<a href="#">Deleting an Aggregate Stop-Loss Pricing Rule of a Parent Customer</a> on page 2442
How to view the details of an aggregate stop-loss pricing rule defined for a parent customer	<a href="#">Viewing an Aggregate Stop-Loss Pricing Rule of a Parent Customer</a> on page 2442
How to define a retention type claim based pricing rule for a parent customer	<a href="#">Defining a Retention Type Claim Based Pricing Rule for a Parent Customer</a> on page 2465
How to edit a retention type claim based pricing rule of a parent customer	<a href="#">Editing a Retention Type Claim Based Pricing Rule of a Parent Customer</a> on page 2469
How to delete a retention type claim based pricing rule of a parent customer	<a href="#">Deleting a Retention Type Claim Based Pricing Rule of a Parent Customer</a> on page 2472

<b>For more information on...</b>	<b>See...</b>
How to view the details of a retention type claim based pricing rule defined for a parent customer	<a href="#">Viewing a Retention Type Claim Based Pricing Rule of a Parent Customer</a> on page 2483
How to define a retention type enrollment based pricing rule for a parent customer	<a href="#">Defining a Retention Type Enrollment Based Pricing Rule for a Parent Customer</a> on page 2493
How to edit a retention type enrollment based pricing rule of a parent customer	<a href="#">Editing a Retention Type Enrollment Based Pricing Rule of a Parent Customer</a> on page 2497
How to delete a retention type enrollment based pricing rule of a parent customer	<a href="#">Deleting a Retention Type Enrollment Based Pricing Rule of a Parent Customer</a> on page 2499
How to view the details of a retention type enrollment based pricing rule defined for a parent customer	<a href="#">Viewing a Retention Type Enrollment Based Pricing Rule of a Parent Customer</a> on page 2511
How to define an ancillary pricing rule for a parent customer	<a href="#">Defining an Ancillary Pricing Rule for a Parent Customer</a> on page 2591
How to edit an ancillary pricing rule of a parent customer	<a href="#">Editing an Ancillary Pricing Rule of a Parent Customer</a> on page 2596
How to delete an ancillary pricing rule of a parent customer	<a href="#">Deleting an Ancillary Pricing Rule of a Parent Customer</a> on page 2598
How to view the details of an ancillary pricing rule defined for a parent customer	<a href="#">Viewing an Ancillary Pricing Rule of a Parent Customer</a>
How to define a discount arrangement pricing rule for a parent customer	<a href="#">Defining a Discount Arrangement Pricing Rule for a Parent Customer</a> on page 2629
How to edit a discount arrangement pricing rule of a parent customer	<a href="#">Editing a Discount Arrangement Pricing Rule of a Parent Customer</a> on page 2637
How to delete a discount arrangement pricing rule of a parent customer	<a href="#">Deleting a Discount Arrangement Pricing Rule of a Parent Customer</a> on page 2639
How to view the details of a discount arrangement pricing rule defined for a parent customer	<a href="#">Viewing the Discount Arrangement Pricing Rule Details of a Parent Customer</a>
How to define a level funded pricing rule for a parent customer	<a href="#">Defining a Level Funded Pricing Rule for a Parent Customer</a> on page 2662
How to edit a level funded pricing rule of a parent customer	<a href="#">Editing a Level Funded Pricing Rule of a Parent Customer</a>
How to delete a level funded pricing rule of a parent customer	<a href="#">Deleting a Level Funded Pricing Rule of a Parent Customer</a>
How to view the details of a level funded pricing rule defined for a parent customer	<a href="#">Viewing the Details of a Level Funded Pricing Rule Defined for a Policy of a Parent Customer</a>

### **Bill Group ASO Policy Pricing Rule Summary**

The **Bill Group ASO Policy Pricing Rule Summary** zone lists the following in a tree view:

- Information string of each effective child person whose person type is set to **Bill Group**) and who is related to the parent customer using a relationship type which is specified in the **Person Relationship Type** option type of the **C1-ASOBLNG** feature configuration
- Information string of each policy to which the bill group is associated.
- Information string of each pricing rule defined for the bill group.

It appears when you are viewing 360° information of a parent customer who is associated with the self-funded policy. It contains the following column:

Column Name	Column Description																						
Hierarchy	Displays information about the bill group, policy, and pricing rule in a tree view. A pricing rule node has a link. On clicking the link, the following screen appears where you can edit the details of the respective pricing rule: <table border="1" data-bbox="527 619 1461 1291"> <thead> <tr> <th>On clicking...</th> <th>Then the following screen appears...</th> </tr> </thead> <tbody> <tr> <td>A claim pricing rule</td> <td>Claim Pricing Rule</td> </tr> <tr> <td>A specific stop-loss pricing rule</td> <td>Specific Stop-Loss (SSL) Pricing Rule</td> </tr> <tr> <td>An aggregate stop-loss pricing rule</td> <td>Aggregate Stop-Loss (ASL) Pricing Rule</td> </tr> <tr> <td>A retention type claim based pricing rule</td> <td>Retention Type Claim Based Pricing Rule</td> </tr> <tr> <td>A retention type enrollment based pricing rule</td> <td>Retention Type Enrollment Based Pricing Rule</td> </tr> <tr> <td>A one-time flat fee pricing rule</td> <td>Flat Fee Pricing Rule</td> </tr> <tr> <td>A bill period based recurring flat fee pricing rule</td> <td>Flat Fee Pricing Rule</td> </tr> <tr> <td>A frequency based recurring flat fee pricing rule</td> <td>Flat Fee Pricing Rule</td> </tr> <tr> <td>An ancillary pricing rule</td> <td>Ancillary Pricing Rule</td> </tr> <tr> <td>A level funded pricing rule</td> <td>Level Funded (LF) Pricing Rule</td> </tr> </tbody> </table>	On clicking...	Then the following screen appears...	A claim pricing rule	Claim Pricing Rule	A specific stop-loss pricing rule	Specific Stop-Loss (SSL) Pricing Rule	An aggregate stop-loss pricing rule	Aggregate Stop-Loss (ASL) Pricing Rule	A retention type claim based pricing rule	Retention Type Claim Based Pricing Rule	A retention type enrollment based pricing rule	Retention Type Enrollment Based Pricing Rule	A one-time flat fee pricing rule	Flat Fee Pricing Rule	A bill period based recurring flat fee pricing rule	Flat Fee Pricing Rule	A frequency based recurring flat fee pricing rule	Flat Fee Pricing Rule	An ancillary pricing rule	Ancillary Pricing Rule	A level funded pricing rule	Level Funded (LF) Pricing Rule
On clicking...	Then the following screen appears...																						
A claim pricing rule	Claim Pricing Rule																						
A specific stop-loss pricing rule	Specific Stop-Loss (SSL) Pricing Rule																						
An aggregate stop-loss pricing rule	Aggregate Stop-Loss (ASL) Pricing Rule																						
A retention type claim based pricing rule	Retention Type Claim Based Pricing Rule																						
A retention type enrollment based pricing rule	Retention Type Enrollment Based Pricing Rule																						
A one-time flat fee pricing rule	Flat Fee Pricing Rule																						
A bill period based recurring flat fee pricing rule	Flat Fee Pricing Rule																						
A frequency based recurring flat fee pricing rule	Flat Fee Pricing Rule																						
An ancillary pricing rule	Ancillary Pricing Rule																						
A level funded pricing rule	Level Funded (LF) Pricing Rule																						

### Related Topics

For more information on...	See...
How to setup the <b>C1-ASOBLNG</b> feature configuration	<a href="#">Setting the C1-ASOBLNG Feature Configuration</a> on page 2889

### **Parent Customer Pricing Rule Summary**

The **Parent Customer Pricing Rule Summary** zone lists the following in a tree view:

- Information string of an effective parent person whose person type is set to **Parent Customer**
- Information string of each pricing rule which is defined for the parent customer

It appears when you are viewing 360° information of a bill group who is associated with the self-funded policy. It contains the following column:

Column Name	Column Description																		
Hierarchy	Displays information about the parent customer and its pricing rules in a tree view. A pricing rule node has a link. On clicking the link, the following screen appears where you can edit the details of the respective pricing rule:																		
	<table border="1"> <thead> <tr> <th>On clicking...</th> <th>Then the following screen appears...</th> </tr> </thead> <tbody> <tr> <td>A claim pricing rule</td> <td>Claim Pricing Rule</td> </tr> <tr> <td>A specific stop-loss pricing rule</td> <td>Specific Stop-Loss (SSL) Pricing Rule</td> </tr> <tr> <td>An aggregate stop-loss pricing rule</td> <td>Aggregate Stop-Loss (ASL) Pricing Rule</td> </tr> <tr> <td>A retention type claim based pricing rule</td> <td>Retention Type Claim Based Pricing Rule</td> </tr> <tr> <td>A retention type enrollment based pricing rule</td> <td>Retention Type Enrollment Based Pricing Rule</td> </tr> <tr> <td>An ancillary pricing rule</td> <td>Ancillary Pricing Rule</td> </tr> <tr> <td>A discount arrangement pricing rule</td> <td>Discount Arrangement Pricing Rule</td> </tr> <tr> <td>A level funded pricing rule</td> <td>Level Funded (LF) Pricing Rule</td> </tr> </tbody> </table>	On clicking...	Then the following screen appears...	A claim pricing rule	Claim Pricing Rule	A specific stop-loss pricing rule	Specific Stop-Loss (SSL) Pricing Rule	An aggregate stop-loss pricing rule	Aggregate Stop-Loss (ASL) Pricing Rule	A retention type claim based pricing rule	Retention Type Claim Based Pricing Rule	A retention type enrollment based pricing rule	Retention Type Enrollment Based Pricing Rule	An ancillary pricing rule	Ancillary Pricing Rule	A discount arrangement pricing rule	Discount Arrangement Pricing Rule	A level funded pricing rule	Level Funded (LF) Pricing Rule
	On clicking...	Then the following screen appears...																	
	A claim pricing rule	Claim Pricing Rule																	
	A specific stop-loss pricing rule	Specific Stop-Loss (SSL) Pricing Rule																	
	An aggregate stop-loss pricing rule	Aggregate Stop-Loss (ASL) Pricing Rule																	
	A retention type claim based pricing rule	Retention Type Claim Based Pricing Rule																	
	A retention type enrollment based pricing rule	Retention Type Enrollment Based Pricing Rule																	
	An ancillary pricing rule	Ancillary Pricing Rule																	
	A discount arrangement pricing rule	Discount Arrangement Pricing Rule																	
A level funded pricing rule	Level Funded (LF) Pricing Rule																		

### Related Topics

For more information on...	See...
How to setup the <b>C1-ASOBLNG</b> feature configuration	<a href="#">Setting the C1-ASOBLNG Feature Configuration</a> on page 2889

### Bill Group ASO Policy Information

The **Bill Group ASO Policy Information** zone appears when you are viewing 360° information of a parent customer or bill group who is associated with the self-funded policy. If you are viewing the 360° information of a parent customer, the **Bill Group ASO Policy Information** zone lists the policies to which each bill group of the parent customer is associated. However, if you are viewing the 360° information of a bill group, the **Bill Group ASO Policy Information** zone lists the policies to which the bill group is associated. It contains the following columns:

Column Name	Column Description
Bill Group Information	Indicates the bill group to which the policy is associated.  <b>Note:</b> It has a link. On clicking the link, the <b>Person</b> screen appears where you can view the details of the respective bill group (i.e. person).
Policy Information	Displays information about the policy.  <b>Note:</b> It has a link. On clicking the link, the <b>Policy</b> screen appears where you can view the details of the respective policy.
Renew	On clicking the <b>Renew</b> (  ) icon, the <b>Policy</b> screen appears where you can renew the policy.  <b>Note:</b> The <b>Renew</b> icon appears only when the policy is in the <b>In Force/Active</b> status and it is not yet renewed.

Column Name	Column Description
Policy Number	Displays the policy number.
Start Date	Displays the date from when the policy is effective.
End Date	Displays the date till when the policy is effective.
Status	Indicates the status of the policy. The valid values are: <ul style="list-style-type: none"> <li>• Pending</li> <li>• In Force/Active</li> <li>• Runout</li> <li>• Post Runout</li> </ul>
Runout End Date	Displays the date when the runout period of the policy ends.
Renewal Date	Displays the date when the policy is renewed.  <b>Note:</b> The data appears in this column only when the policy is renewed.

**Note:** Pagination is used to display limited number of records in this zone. You can use the navigation links, such as **Previous** and **Next** to navigate between pages.

On clicking the **Broadcast**  icon corresponding to a bill group and policy combination, the **Bill Group ASO Policy Pricing Rules** and **Bill Group Pricing Groups** zones appear.

You can filter the list using various search criteria (such as, **Bill Group Name**, **Policy Start Date**, and **Policy End Date**) available in the **Filter** area. By default, the **Filter** area is hidden. You can view the **Filter** area by clicking the **Filters**  icon in the upper right corner of this zone.



### Related Topics

For more information on...	See...
<b>Bill Group ASO Policy Pricing Rules</b> zone	<a href="#">Bill Group ASO Policy Pricing Rules</a> on page 237
<b>Bill Group Pricing Groups</b> zone	<a href="#">Bill Group Pricing Groups</a> on page 242
How to view the pricing rules defined for a policy of a bill group	<a href="#">Viewing the Pricing Rules Defined for a Policy of a Bill Group</a> on page 258
How to view the pricing groups of a bill group	<a href="#">Viewing the Pricing Groups of a Bill Group</a> on page 259

### **Bill Group ASO Policy Pricing Rules**

The **Bill Group ASO Policy Pricing Rules** zone lists the pricing rules which are defined for a policy of a bill group. It appears when you are viewing 360° information of a parent customer or bill group who is associated with the self-funded policy. It contains the following columns:

Column Name	Column Description
Pricing Rule Type	Indicates the pricing rule type using which the pricing rule is created.  <b>Note:</b> It has a link. On clicking the link, the <b>Pricing Rule Type</b> screen appears where you can view the details of the respective pricing rule type.

Column Name	Column Description																						
Pricing Rule Information	<p>Displays information about the pricing rule.</p> <p><b>Note:</b> It has a link. On clicking the link, the <b>Pricing Rule</b> screen appears where you can view the details of the respective pricing rule.</p>																						
Price Item Information	<p>Indicates the price item for which the pricing rule is created.</p> <p><b>Note:</b> It has a link. On clicking the link, the <b>Price Item</b> screen appears where you can view the details of the respective price item.</p>																						
Start Date	Displays the date from when the pricing rule is effective.																						
End Date	Displays the date till when the pricing rule is effective.																						
Status	<p>Indicates the status of the pricing rule. The valid values are:</p> <ul style="list-style-type: none"> <li>• Pending</li> <li>• Active</li> </ul>																						
Edit	<p>On clicking the <b>Edit</b> () icon, the following screen appears where you can edit the details of the respective pricing rule:</p> <table border="1"> <thead> <tr> <th>If you are editing...</th> <th>Then the following screen appears...</th> </tr> </thead> <tbody> <tr> <td>A claim pricing rule</td> <td>Claim Pricing Rule</td> </tr> <tr> <td>A specific stop-loss pricing rule</td> <td>Specific Stop-Loss (SSL) Pricing Rule</td> </tr> <tr> <td>An aggregate stop-loss pricing rule</td> <td>Aggregate Stop-Loss (ASL) Pricing Rule</td> </tr> <tr> <td>A retention type claim based pricing rule</td> <td>Retention Type Claim Based Pricing Rule</td> </tr> <tr> <td>A retention type enrollment based pricing rule</td> <td>Retention Type Enrollment Based Pricing Rule</td> </tr> <tr> <td>A one-time flat fee pricing rule</td> <td>Flat Fee Pricing Rule</td> </tr> <tr> <td>A bill period based recurring flat fee pricing rule</td> <td>Flat Fee Pricing Rule</td> </tr> <tr> <td>A frequency based recurring flat fee pricing rule</td> <td>Flat Fee Pricing Rule</td> </tr> <tr> <td>An ancillary pricing rule</td> <td>Ancillary Pricing Rule</td> </tr> <tr> <td>A level funded pricing rule</td> <td>Level Funded (LF) Pricing Rule</td> </tr> </tbody> </table>	If you are editing...	Then the following screen appears...	A claim pricing rule	Claim Pricing Rule	A specific stop-loss pricing rule	Specific Stop-Loss (SSL) Pricing Rule	An aggregate stop-loss pricing rule	Aggregate Stop-Loss (ASL) Pricing Rule	A retention type claim based pricing rule	Retention Type Claim Based Pricing Rule	A retention type enrollment based pricing rule	Retention Type Enrollment Based Pricing Rule	A one-time flat fee pricing rule	Flat Fee Pricing Rule	A bill period based recurring flat fee pricing rule	Flat Fee Pricing Rule	A frequency based recurring flat fee pricing rule	Flat Fee Pricing Rule	An ancillary pricing rule	Ancillary Pricing Rule	A level funded pricing rule	Level Funded (LF) Pricing Rule
If you are editing...	Then the following screen appears...																						
A claim pricing rule	Claim Pricing Rule																						
A specific stop-loss pricing rule	Specific Stop-Loss (SSL) Pricing Rule																						
An aggregate stop-loss pricing rule	Aggregate Stop-Loss (ASL) Pricing Rule																						
A retention type claim based pricing rule	Retention Type Claim Based Pricing Rule																						
A retention type enrollment based pricing rule	Retention Type Enrollment Based Pricing Rule																						
A one-time flat fee pricing rule	Flat Fee Pricing Rule																						
A bill period based recurring flat fee pricing rule	Flat Fee Pricing Rule																						
A frequency based recurring flat fee pricing rule	Flat Fee Pricing Rule																						
An ancillary pricing rule	Ancillary Pricing Rule																						
A level funded pricing rule	Level Funded (LF) Pricing Rule																						
Delete	<p>On clicking the <b>Delete</b> () icon, you can delete the pricing rule.</p> <p><b>Note:</b> You can delete a pricing rule only when it is not yet used in the system.</p>																						
Pricing Group Information	Indicates the pricing group which is used while defining the pricing rule.																						

Column Name	Column Description
Price List Information	Indicates the price list which contains the price item pricing which is created through the pricing rule.  <b>Note:</b> It has a link. On clicking the link, the <b>Price List</b> screen appears where you can view the details of the respective price list.

**Note:** Pagination is used to display limited number of records in this zone. You can use the navigation links, such as **Previous** and **Next** to navigate between pages.

By default, the **Bill Group ASO Policy Pricing Rules** zone does not appear in the **Pricing** tab of the **Customer 360° Information** screen. It appears only when you click the **Broadcast**  icon corresponding to a bill group and policy combination in the **Bill Group ASO Policy Information** zone.

You can define a new pricing rule for the bill group by clicking the **Add** link in the upper right corner of this zone.

You can filter the list using various search criteria (such as, **Price Item**, **Start Date**, **Pricing Rule Type**, **End Date**, and **Status**) available in the **Filter** area. By default, the **Filter** area is hidden. You can view the **Filter** area by clicking the **Filters**  icon in the upper right corner of this zone.

You can change the layout of this zone. For more information on how to change the layout, see [Changing the Layout](#) on page 2882.

### Related Topics

For more information on...	See...
How to define a claim pricing rule for a policy of a bill group	<a href="#">Defining a Claim Pricing Rule for a Bill Group</a> on page 2375
How to edit a claim pricing rule defined for a policy of a bill group	<a href="#">Editing a Claim Pricing Rule of a Bill Group</a> on page 2381
How to delete a claim pricing rule defined for a policy of a bill group	<a href="#">Deleting a Claim Pricing Rule of a Bill Group</a> on page 2383
How to view the details of a claim pricing rule defined for a policy of a bill group	<a href="#">Viewing a Claim Pricing Rule of a Bill Group</a> on page 2382
How to define a claim pricing rule for a policy of a bill group using a pricing group	<a href="#">Defining a Claim Pricing Rule for a Bill Group Using a Pricing Group</a> on page 2378
How to define a specific stop-loss pricing rule for a policy of a bill group	<a href="#">Defining a Specific Stop-Loss Pricing Rule for a Bill Group</a> on page 2407
How to edit a specific stop-loss pricing rule defined for a policy of a bill group	<a href="#">Editing a Specific Stop-Loss Pricing Rule of a Bill Group</a> on page 2417
How to delete a specific stop-loss pricing rule defined for a policy of a bill group	<a href="#">Deleting a Specific Stop-Loss Pricing Rule of a Bill Group</a> on page 2419
How to view the details of a specific stop-loss pricing rule defined for a policy of a bill group	<a href="#">Viewing a Specific Stop-Loss Pricing Rule of a Bill Group</a> on page 2418
How to define a specific stop-loss pricing rule for a policy of a bill group using a pricing group	<a href="#">Defining a Specific Stop-Loss Pricing Rule for a Bill Group Using a Pricing Group</a> on page 2414

<b>For more information on...</b>	<b>See...</b>
How to define an aggregate stop-loss pricing rule for a policy of a bill group	<a href="#">Defining an Aggregate Stop-Loss Pricing Rule for a Bill Group</a> on page 2443
How to edit an aggregate stop-loss pricing rule defined for a policy of a bill group	<a href="#">Editing an Aggregate Stop-Loss Pricing Rule of a Bill Group</a> on page 2453
How to delete an aggregate stop-loss pricing rule defined for a policy of a bill group	<a href="#">Deleting an Aggregate Stop-Loss Pricing Rule of a Bill Group</a> on page 2455
How to view the details of an aggregate stop-loss pricing rule defined for a policy of a bill group	<a href="#">Viewing an Aggregate Stop-Loss Pricing Rule of a Bill Group</a> on page 2454
How to define an aggregate stop-loss pricing rule for a policy of a bill group using a pricing group	<a href="#">Defining an Aggregate Stop-Loss Pricing Rule for a Bill Group Using a Pricing Group</a> on page 2450
How to define a retention type claim based pricing rule for a policy of a bill group	<a href="#">Defining a Retention Type Claim Based Pricing Rule for a Bill Group</a> on page 2473
How to edit a retention type claim based pricing rule defined for a policy of a bill group	<a href="#">Editing a Retention Type Claim Based Pricing Rule of a Bill Group</a> on page 2476
How to delete a retention type claim based pricing rule defined for a policy of a bill group	<a href="#">Deleting a Retention Type Claim Based Pricing Rule of a Bill Group</a> on page 2479
How to view the details of a retention type claim based pricing rule defined for a policy of a bill group	<a href="#">Viewing a Retention Type Claim Based Pricing Rule of a Bill Group</a> on page 2484
How to define a retention type claim based pricing rule for a policy of a bill group using a pricing group	<a href="#">Defining a Retention Type Claim Based Pricing Rule for a Bill Group Using a Pricing Group</a> on page 2479
How to define a retention type enrollment based pricing rule for a policy of a bill group	<a href="#">Defining a Retention Type Enrollment Based Pricing Rule for a Bill Group</a> on page 2500
How to edit a retention type enrollment based pricing rule defined for a policy of a bill group	<a href="#">Editing a Retention Type Enrollment Based Pricing Rule of a Bill Group</a> on page 2504
How to delete a retention type enrollment based pricing rule defined for a policy of a bill group	<a href="#">Deleting a Retention Type Enrollment Based Pricing Rule of a Bill Group</a> on page 2507
How to view the details of a retention type enrollment based pricing rule defined for a policy of a bill group	<a href="#">Viewing a Retention Type Enrollment Based Pricing Rule of a Bill Group</a> on page 2512
How to define a retention type enrollment based pricing rule for a policy of a bill group using a pricing group	<a href="#">Defining a Retention Type Enrollment Based Pricing Rule for a Bill Group Using a Pricing Group</a> on page 2507
How to define a one-time flat fees pricing rule for a policy of a bill group	<a href="#">Defining a One-Time Flat Fee Pricing Rule for a Bill Group</a> on page 2522





<b>For more information on...</b>	<b>See...</b>
How to edit a one-time flat fees pricing rule defined for a policy of a bill group	<a href="#">Editing a One-Time Flat Fee Pricing Rule of a Bill Group</a> on page 2526
How to delete a one-time flat fees pricing rule defined for a policy of a bill group	<a href="#">Deleting a One-Time Flat Fee Pricing Rule of a Bill Group</a> on page 2528
How to view the details of a one-time flat fees pricing rule defined for a policy of a bill group	<a href="#">Viewing a One-Time Flat Fee Pricing Rule of a Bill Group</a> on page 2527
How to define a bill period based recurring flat fees pricing rule for a policy of a bill group	<a href="#">Defining a Bill Period Based Recurring Flat Fee Pricing Rule for a Bill Group</a> on page 2537
How to edit a bill period based recurring flat fees pricing rule defined for a policy of a bill group	<a href="#">Editing a Bill Period Based Recurring Flat Fee Pricing Rule of a Bill Group</a> on page 2541
How to delete a bill period based recurring flat fees pricing rule defined for a policy of a bill group	<a href="#">Deleting a Bill Period Based Recurring Flat Fee Pricing Rule of a Bill Group</a> on page 2543
How to view the details of a bill period based recurring flat fees pricing rule defined for a policy of a bill group	<a href="#">Viewing a Bill Period Based Recurring Flat Fee Pricing Rule of a Bill Group</a> on page 2542
How to define a frequency based recurring flat fees pricing rule for a policy of a bill group	<a href="#">Defining a Frequency Based Recurring Flat Fee Pricing Rule for a Bill Group</a> on page 2552
How to edit a frequency based recurring flat fees pricing rule defined for a policy of a bill group	<a href="#">Editing a Frequency Based Recurring Flat Fee Pricing Rule of a Bill Group</a> on page 2555
How to delete a frequency based recurring flat fees pricing rule defined for a policy of a bill group	<a href="#">Deleting a Frequency Based Recurring Flat Fee Pricing Rule of a Bill Group</a> on page 2558
How to view the details of a frequency based recurring flat fees pricing rule defined for a policy of a bill group	<a href="#">Viewing a Frequency Based Recurring Flat Fee Pricing Rule of a Bill Group</a> on page 2557
How to define an ancillary pricing rule for a policy of a bill group	<a href="#">Defining an Ancillary Pricing Rule for a Bill Group</a> on page 2599
How to edit an ancillary pricing rule defined for a policy of a bill group	<a href="#">Editing an Ancillary Pricing Rule of a Bill Group</a> on page 2604
How to delete an ancillary pricing rule defined for a policy of a bill group	<a href="#">Deleting an Ancillary Pricing Rule of a Bill Group</a> on page 2606
How to view the details of an ancillary pricing rule defined for a policy of a bill group	<a href="#">Viewing an Ancillary Pricing Rule of a Bill Group</a>
How to define an ancillary pricing rule for a policy of a bill group using a pricing group	<a href="#">Defining an Ancillary Pricing Rule for a Bill Group Using a Pricing Group</a>
How to define a level funded pricing rule for a policy of a bill group	<a href="#">Defining a Level Funded Pricing Rule for a Bill Group</a> on page 2672

For more information on...	See...
How to edit a level funded pricing rule defined for a policy of a bill group	<a href="#">Editing a Level Funded Pricing Rule of a Bill Group</a>
How to delete a level funded pricing rule defined for a policy of a bill group	<a href="#">Deleting a Level Funded Pricing Rule Defined for a Policy of a Bill Group</a>
How to view the details of a level funded pricing rule defined for a policy of a bill group	<a href="#">Viewing the Details of a Level Funded Pricing Rule Defined for a Policy of a Bill Group</a>
How to define a level funded pricing rule for a policy of a bill group using a pricing group	<a href="#">Defining a Level Funded Pricing Rule for a Bill Group</a> on page 2672

### Bill Group Pricing Groups

The **Bill Group Pricing Groups** zone lists the pricing groups which are defined for the bill group. By default, the active pricing groups are listed in this zone. It appears when you are viewing 360° information of a bill group who is associated with the self-funded policy. It contains the following columns:

Column Name	Column Description
Pricing Group	Indicates the pricing group which is created for the bill group.
Status	Indicates the status of the pricing group. The valid values are: <ul style="list-style-type: none"> <li>Active</li> <li>Inactive</li> </ul>
Edit	On clicking the <b>Edit</b> (  ) icon, the <b>Pricing Group</b> screen appears where you can edit the details of the pricing group.
Delete	On clicking the <b>Delete</b> (  ) icon, you can delete the pricing group. <div style="border: 1px solid black; padding: 5px; margin-top: 10px;"> <p><b>Note:</b> You can delete a pricing group only when it is not yet used while defining a pricing rule for the bill group.</p> </div>
Duplicate	On clicking the <b>Duplicate</b> (  ) icon, the <b>Pricing Group</b> screen appears where you can define a new pricing group using an existing pricing group.
Associated Price Items	Indicates the price items whose pricing is defined using the pricing group.

**Note:** Pagination is used to display limited number of records in this zone. You can use the navigation links, such as **Previous** and **Next** to navigate between pages.

By default, the **Bill Group Pricing Groups** zone does not appear in the **Pricing** tab of the **Customer 360° Information** screen. It appears only when you click the **Broadcast** () icon corresponding to a bill group in the **Bill Group Policy Information** zone.

You can define a new pricing group for the bill group by clicking the **Add** link in the upper right corner of this zone.

You can filter the list using the **Show All** field available in the **Filter** area. By default, the **Filter** area is hidden. You can view the **Filter** area by clicking the **Filters** () icon in the upper right corner of this zone.

**Note:** If you select the **Yes** option from the **Show All** list, the system lists both the active and inactive pricing groups in the **Bill Group Pricing Groups** zone.

You can change the layout of this zone. For more information on how to change the layout, see [Changing the Layout](#) on page 2882.

### **Related Topics**

<b>For more information on...</b>	<b>See...</b>
How to define a pricing group for a bill group	<a href="#">Defining a Pricing Group for a Bill Group</a> on page 2334
How to edit a pricing group of a bill group	<a href="#">Editing a Pricing Group of a Bill Group</a> on page 2337
How to copy a pricing group of a bill group	<a href="#">Copying a Pricing Group of a Bill Group</a> on page 2340
How to delete a pricing group of a bill group	<a href="#">Deleting a Pricing Group of a Bill Group</a> on page 2339

### **Pricing Rule Approval Transactions**

The **Pricing Rule Approval Transactions** zone lists the following information:

<b>If you are viewing the 360° information of...</b>	<b>Then...</b>
A parent customer who is associated with the self-funded policy	The <b>Pricing Rule Approval Transactions</b> zone lists the approval transactions which are created while defining, editing, and deleting the parent customer's and bill groups' pricing rules.
A bill group who is associated with the self-funded policy	The <b>Pricing Rule Approval Transactions</b> zone lists the approval transactions which are created while defining, editing, and deleting the pricing rules of the bill group.
A parent customer who is associated with the fully-insured group policy	The <b>Pricing Rule Approval Transactions</b> zone lists the approval transactions which are created while defining, editing, and deleting the parent customer and its bill groups' policy plans' pricing rules.
A bill group who is associated with the fully-insured group policy	The <b>Pricing Rule Approval Transactions</b> zone lists the approval transactions which are created while defining, editing, and deleting the bill group's policy plans' pricing rules.

It contains the following columns:

<b>Column Name</b>	<b>Column Description</b>
Submitted On	Displays the date and time when the approval transaction is created by the submitter.
Approval Transaction ID	Displays the approval transaction ID.  <b>Note:</b> It has a link. On clicking the link, the <b>Comparison: New versus Existing</b> screen appears where you can review and accordingly approve, reject, or revert the changes.
Pricing Level	Indicates whether the approval transaction is created for a pricing rule which is defined at the parent customer or bill group level. The valid values are: <ul style="list-style-type: none"> <li>• Parent Customer</li> <li>• Bill Group</li> </ul>
Person Name	Indicates the person for whom the pricing rule is created.
Pricing Rule Type	Indicates the pricing rule type using which the pricing rule is created.

Column Name	Column Description
Price Item Information	Indicates the price item for which the pricing rule is created.  <b>Note:</b> It has a link. On clicking the link, the <b>Price Item</b> screen appears where you can view the details of the respective price item.
Start Date	Displays the date from when the pricing rule is effective.
End Date	Displays the date till when the pricing rule is effective.
Approval Status	Indicates the status of the approval transaction. The valid values are: <ul style="list-style-type: none"> <li>• Approved</li> <li>• Cancelled</li> <li>• Deleted</li> <li>• Inprocess</li> <li>• Pending</li> <li>• Rejected</li> </ul>
Action	Indicates the type of action performed by the submitter on the pricing rule. The valid values are: <ul style="list-style-type: none"> <li>• Add</li> <li>• Update</li> <li>• Delete</li> </ul>
Submitted By	Indicates the user who has performed the action on the pricing rule.
Assigned To	Indicates the user to whom the approval transaction is manually assigned for review.
Approved/Rejected By	Indicates the user who has approved or rejected the approval transaction.

**Note:** Pagination is used to display limited number of records in this zone. You can use the navigation links, such as **Previous** and **Next** to navigate between pages.

You can filter the list using various search criteria (such as, **Status**, **Assigned To**, and **Price Item**) available in the **Filter** area. By default, the **Filter** area is hidden. You can view the **Filter** area by clicking the **Filters**  icon in the upper right corner of this zone.

### Policy Plan Pricing Rule Summary

The **Policy Plan Pricing Rule Summary** zone lists the following in a tree view:

- Information string of each fully-insured policy where the parent customer is associated
- Information string of each plan defined on the fully-insured policy of the parent customer
- Information string of each fully-insured policy of an effective child person whose person type is set to **Bill Group** and who is related to the parent customer using a relationship type which is specified in the **Person Relationship Type** option type of the **C1-ASOBLNG** feature configuration
- Information string of each plan defined on the fully-insured policy of the bill group
- Information string of each pricing rule defined on the policy plan

It appears when you are viewing 360° information of a parent customer who is associated with the fully-insured policy. It contains the following column:

Column Name	Column Description
Hierarchy	Displays information about the policy, policy plan, and pricing rule in a tree view.

### Related Topics

For more information on...	See...
How to setup the <b>C1-ASOBLLNG</b> feature configuration	<a href="#">Setting the C1-ASOBLLNG Feature Configuration</a> on page 2889

### Policy Plan Information

The **Policy Plan Information** zone appears when you are viewing 360° information of a parent customer or bill group who is associated with the fully-insured policy. If you are viewing the 360° information of a parent customer, the **Policy Plan Information** zone lists the policy plans of the fully-insured policies to which the parent customer and its bill groups are associated. However, if you are viewing the 360° information of a bill group, the **Bill Group ASO Policy Information** zone lists the policy plans of the fully-insured policies to which the bill group is associated. It contains the following columns:

Column Name	Column Description
Policy Plan Information	Displays information about the policy plan. In addition, this column has a context menu which helps in navigating to other screens in the application.  <b>Note:</b> It has a link. On clicking the link, the <b>Policy Plan</b> screen appears where you can view the details of the respective policy plan.
Policy Number	Displays the policy number.
Policy Type	Indicates the type of the policy.
Plan Name	Indicates the price item associated with the policy plan.
Start Date	Displays the date from when the policy plan is effective.
End Date	Displays the date till when the policy plan is effective.
No. of Subscribers	Indicates the number of main subscribers in the policy plan.
No. of Members	Indicates the number of members in the policy plan.

**Note:** Pagination is used to display limited number of records in this zone. You can use the navigation links, such as **Previous** and **Next** to navigate between pages.

On clicking the **Broadcast**  icon corresponding to a policy plan, the **Policy Plan Pricing Rules** zone appears where you can view the pricing rules defined for the policy plan.

You can filter the list using various search criteria (such as, **Policy Type**, **Plan Start Date**, and **Plan End Date**) available in the **Filter** area. By default, the **Filter** area is hidden. You can view the **Filter** area by clicking the **Filters**  icon in the upper right corner of this zone.

### Related Topics

For more information on...	See...
<b>Policy Plan Pricing Rules</b> zone	<a href="#">Policy Plan Pricing Rules</a> on page 246
How to view the pricing rules defined for a policy plan	<a href="#">Viewing the Pricing Rules Defined for a Policy Plan</a> on page 263

## Policy Plan Pricing Rules

The **Policy Plan Pricing Rules** zone lists the pricing rules which are defined for a fully-insured policy plan. It appears when you are viewing 360° information of a parent customer or bill group who is associated with the fully-insured policy. It contains the following columns:

Column Name	Column Description
Pricing Rule Type	Indicates the pricing rule type using which the pricing rule is created.  <b>Note:</b> It has a link. On clicking the link, the <b>Pricing Rule Type</b> screen appears where you can view the details of the respective pricing rule type.
Pricing Rule Information	Displays information about the pricing rule.  <b>Note:</b> It has a link. On clicking the link, the <b>Pricing Rule</b> screen appears where you can view the details of the respective pricing rule.
Price Item Information	Indicates the price item for which the pricing rule is created.  <b>Note:</b> It has a link. On clicking the link, the <b>Price Item</b> screen appears where you can view the details of the respective price item.
Start Date	Displays the date from when the pricing rule is effective.
End Date	Displays the date till when the pricing rule is effective.
Price List Information	Indicates the price list which contains the price item pricing which is created through the pricing rule.  <b>Note:</b> It has a link. On clicking the link, the <b>Price List</b> screen appears where you can view the details of the respective price list.

### Note:

Pagination is used to display limited number of records in this zone. You can use the navigation links, such as **Previous** and **Next** to navigate between pages.

You can define and edit a pricing rule for a policy plan through a healthcare inbound message and not from the user interface.

By default, the **Policy Plan Pricing Rules** zone does not appear in the **Pricing** tab of the **Customer 360° Information** screen. It appears only when you click the **Broadcast**  icon corresponding to a policy plan in the **Policy Plan Information** zone.

You can filter the list using various search criteria (such as, **Price Item**, **Start Date**, **Pricing Rule Type**, **End Date**, and **Status**) available in the **Filter** area. By default, the **Filter** area is hidden. You can view the **Filter** area by clicking the **Filters**  icon in the upper right corner of this zone.

You can change the layout of this zone. For more information on how to change the layout, see [Changing the Layout](#) on page 2882.

### Related Topics

For more information on...	See...
Health Care Inbound Message XML Format	<a href="#">Health Care Inbound Message XML Format</a> on page 1875

<b>For more information on...</b>	<b>See...</b>
Sample Pricing Rules Inbound Message	<a href="#">Sample Health Care Inbound Message for Pricing Rules</a> on page 1960

## Defining a Sort ID for a Bill Group

### Prerequisites

To define a sort ID for a bill group, you should have:

- Effective child persons whose person type is set to **Bill Group** and who are related to the parent customer using a relationship type which is specified in the **Person Relationship Type** option type of the **C1-ASOBLNG** feature configuration

### Procedure

To define a sort ID for a bill group:

- Search for a person whose person type is set to **Parent Customer** in the **Customer 360° View** screen.
- In the **Search Results** section, click the **View** () icon corresponding to the person whose details you want to view.

The **Person** tab appears in the **Customer 360° Information** screen.

- Expand the **Bill Group Sorting** zone.

**Note:** The **Bill Group Sorting** zone appears when you are viewing the 360° information of a person whose person type is set to **Parent Customer**.

- Click the **Add** link in the upper right corner of the **Bill Group Sorting** zone.

The **Bill Group Sorting** screen appears. It contains the following field:

Field Name	Field Description
Parent Customer	Indicates the parent customer whose bill groups' sort IDs you want to define.

In addition, it contains the following fields in a grid:

Field Name	Field Description	Mandatory (Yes or No)
Bill Group Information	Used to indicate the bill group for whom you want to define the sort ID.  <b>Note:</b> The values appear in this list only when there are effective child persons whose person type is set to <b>Bill Group</b> and who are related to the parent customer using a relationship type which is specified in the <b>Person Relationship Type</b> parameter of the <b>C1-ASOBLNG</b> feature configuration.	Yes
Description	Used to specify the description for the sort ID.	Yes
Sort ID	Used to specify the sort ID.	Yes
Start Date	Used to specify the date from when the sort ID is effective for the bill group.  <b>Note:</b> The start date cannot be later than the end date.	Yes

Field Name	Field Description	Mandatory (Yes or No)
End Date	Used to specify the date till when the sort ID is effective for the bill group.  <b>Note:</b> The end date cannot be earlier than the start date.	No

- Enter the required details in the grid.
- If you want to define more than one sort ID for a bill group, click the **Add** (  ) icon and then repeat step 5.

**Note:** However, if you want to remove a sort ID of a bill group, click the **Delete** (  ) icon corresponding to the bill group and sort ID combination.

- Click **Save**.

A sort ID is defined for the bill group.

### Related Topics

For more information on...	See...
How to search for a person	<a href="#">Searching for a Person</a> on page 185
<b>Customer 360° Information</b> screen	<a href="#">Customer 360° Information</a> on page 196
<b>Person</b> tab	<a href="#">Customer 360° Information - Person</a> on page 201
<b>Bill Group Sorting</b> zone	<a href="#">Bill Group Sorting</a> on page 210
How to setup the <b>C1-ASOBLNG</b> feature configuration	<a href="#">Setting the C1-ASOBLNG Feature Configuration</a> on page 2889

## Editing a Sort ID of a Bill Group

### Procedure

To edit a sort ID of a bill group:

- Search for a person whose person type is set to **Parent Customer** in the **Customer 360° View** screen.
- In the **Search Results** section, click the **View** (  ) icon corresponding to the person whose details you want to view.

The **Person** tab appears in the **Customer 360° Information** screen.

- Expand the **Bill Group Sorting** zone.

**Note:** The **Bill Group Sorting** zone appears when you are viewing the 360° information of a person whose person type is set to **Parent Customer**.

- In the **Bill Group Sorting** zone, select the check box corresponding to the bill group and sort ID combination whose details you want to edit.

**Note:** If you want to edit all sort IDs of effective bill groups, you need to select the check box corresponding to the column header. In such case, the system considers only those records which are present on the respective page for editing.

- Click **Edit**.

The **Bill Group Sorting** screen appears. It contains the following field:



Field Name	Field Description
Parent Customer	Indicates the parent customer whose bill groups' sort IDs you want to edit.

In addition, it contains the following fields in a grid:

Field Name	Field Description	Mandatory (Yes or No)
Bill Group Information	Indicates the bill group whose sort ID you want to edit.	Not applicable
Description	Used to specify the description for the sort ID.	Yes
Sort ID	Displays the sort ID.	Not applicable
Start Date	Used to specify the date from when the sort ID is effective for the bill group.  <div style="border: 1px solid black; padding: 5px;"> <p><b>Note:</b> The start date cannot be later than the end date. The start date cannot be later than the effective date specified in the derivation and pricing parameters which are defined for the bill group and sort ID combination.</p> </div>	Yes
End Date	Used to specify the date till when the sort ID is effective for the bill group.  <div style="border: 1px solid black; padding: 5px;"> <p><b>Note:</b> The end date cannot be earlier than the start date. The end date cannot be earlier than the effective date specified in the derivation and pricing parameters which are defined for the bill group and sort ID combination.</p> </div>	No

6. Modify the details of a bill group's sort ID, if required.
7. Click **Save**.

The changes made to the bill group's sort ID are saved.

#### **Related Topics**

For more information on...	See...
How to search for a person	<a href="#">Searching for a Person</a> on page 185
<b>Customer 360° Information</b> screen	<a href="#">Customer 360° Information</a> on page 196
<b>Person</b> tab	<a href="#">Customer 360° Information - Person</a> on page 201
<b>Bill Group Sorting</b> zone	<a href="#">Bill Group Sorting</a> on page 210

## Deleting a Sort ID of a Bill Group

### **Procedure**

To delete a sort ID of a bill group:

1. Search for a person whose person type is set to **Parent Customer** in the **Customer 360° View** screen.
2. In the **Search Results** section, click the **View** () icon corresponding to the person whose details you want to view.

The **Person** tab appears in the **Customer 360° Information** screen.

3. Expand the **Bill Group Sorting** zone.

**Note:** The **Bill Group Sorting** zone appears when you are viewing the 360° information of a person whose person type is set to **Parent Customer**.

4. In the **Bill Group Sorting** zone, select the check box corresponding to the bill group and sort ID combination that you want to delete.

**Note:** If you want to delete all sort IDs of effective bill groups, you need to select the check box corresponding to the column header. In such case, the system considers only those records which are present on the respective page for deleting.

5. Click **Delete**.

A message appears confirming whether you want to delete the bill group's sort ID.

**Note:** You can delete a bill group's sort ID only when the derivation and pricing parameters are not yet defined for the bill group and sort ID combination.

6. Click **OK**.

The bill group's sort ID is deleted.

### **Related Topics**

<b>For more information on...</b>	<b>See...</b>
How to search for a person	<a href="#">Searching for a Person</a> on page 185
<b>Customer 360° Information</b> screen	<a href="#">Customer 360° Information</a> on page 196
<b>Person</b> tab	<a href="#">Customer 360° Information - Person</a> on page 201
<b>Bill Group Sorting</b> zone	<a href="#">Bill Group Sorting</a> on page 210

## **Creating a Bill Group Sorting Upload Request**

### **Procedure**

To create a bill group sorting upload request:

1. Search for a person whose person type is set to **Parent Customer** in the **Customer 360° View** screen.
2. In the **Search Results** section, click the **View** () icon corresponding to the person whose details you want to view.

The **Person** tab appears in the **Customer 360° Information** screen.

3. Expand the **Bill Group Sorting** zone.

**Note:** The **Bill Group Sorting** zone appears when you are viewing the 360° information of a person whose person type is set to **Parent Customer**.

4. Click the **Upload** link in the upper right corner of the **Bill Group Sorting** zone.

The **Select Upload Request Type** screen appears. It contains the following field:

Field Name	Field Description	Mandatory (Yes or No)
Upload Request Type	Used to indicate the upload request type using which you want to create the upload request.  <b>Note:</b> The list includes only those upload request types where the upload request business object with the <b>Upload Type</b> option type set to <b>BG</b> is selected.	Yes

**Note:** The **Select Upload Request Type** screen appears only when there are multiple upload request types where the upload request business object with the **Upload Type** option type set to **BG** is selected. If there is only one such upload request type defined in the application, the **Bill Group Sorting Upload Request** screen appears.

5. Select the required upload request type from the respective field.
6. Click **OK**.

The **Bill Group Sorting Upload Request** screen appears. It contains the following sections:

- **Main** – Used to specify basic details about the upload request.
- **Characteristics** – Used to define characteristics for the upload request.

The **Main** section contains the following fields:

Field Name	Field Description	Mandatory (Yes or No)
Upload Request Type	Indicates the upload request type using which the bill group sorting upload request will be created.	Not applicable
Parent Customer	Used to indicate the person for whom you want to create the bill group sorting upload request.  <b>Note:</b> By default, the parent customer's ID appears in this field. You can change the person, if required.  The system allows you to create a bill group sorting upload request for a person whose person type is set to <b>Parent Customer</b> .  The <b>Search</b>  icon appears corresponding to this field. On clicking the <b>Search</b> icon, the <b>Person Search</b> window appears.	Yes

Field Name	Field Description	Mandatory (Yes or No)
File Name	Used to specify the name and path of the file that you want to upload.  <b>Note:</b> You can also click the <b>Browse</b> button corresponding to this field to browse to the location where the file is available in the system.	Yes
Replace Existing File	Used to indicate whether you want to replace any existing file in the system. You must select this check box when you want to upload the same file once again.	No
Comments	Used to specify additional information about the upload request.	No

- Click the **Browse** button corresponding to the **File Name** field.

The **Choose File to Upload** dialog box appears.

- Browse to the location where the file that you want to upload is available in the system.

- Click **Open**.

The file name along with the path appears in the **File Name** field.

- Select the **Replace Existing File** check box depending on whether you want to upload the same file once again in the system.

- Define characteristics for the upload request, if required.

- Click **Save**.

A message appears indicating the number of records which are successfully uploaded. Then, a bill group sorting upload request is created in the **Draft** status. If the bill group ID is available in the record, the status of the record is set to **Pending**. However, if the system could not derive the bill group ID using the bill group identifier type and bill group identifier combination when the bill group ID is not specified in the record, the status of the record is set to **Invalid**.

### Related Topics

For more information on...	See...
How to search for a person	<a href="#">Searching for a Person</a> on page 185
<b>Customer 360° Information</b> screen	<a href="#">Customer 360° Information</a> on page 196
<b>Person</b> tab	<a href="#">Customer 360° Information - Person</a> on page 201
<b>Bill Group Sorting</b> zone	<a href="#">Bill Group Sorting</a> on page 210
How to define characteristics for an upload request	<a href="#">Defining Characteristics for an Upload Request</a> on page 1663

## Defining the Derivation and Pricing Parameters for a Bill Group and Sort ID Combination

### Prerequisites

To define the derivation and pricing parameters for a bill group and sort ID combination, you should have:

- Effective child persons whose person type is set to **Bill Group** and who are related to the parent customer using a relationship type which is specified in the **Person Relationship Type** option type of the **C1-ASOBLNG** feature configuration
- Sort ID defined for the bill group
- Values defined for the **C1-SourceSystemLookup** extendable lookup

### Procedure

To define the derivation and pricing parameters for a bill group and sort ID combination:

1. Search for a person whose person type is set to **Parent Customer** in the **Customer 360° View** screen.
2. In the **Search Results** section, click the **View** () icon corresponding to the person whose details you want to view.

The **Person** tab appears in the **Customer 360° Information** screen.

3. Expand the **Bill Group Derivation and Pricing Parameters** zone.

**Note:** The **Bill Group Derivation and Pricing Parameters** zone appears when you are viewing the 360° information of a person whose person type is set to **Parent Customer**.

4. Click the **Add** link in the upper right corner of the **Bill Group Derivation and Pricing Parameters** zone.

The **Bill Group Derivation and Pricing Parameters** screen appears. It contains the following field:

Field Name	Field Description
Parent Customer	Indicates the parent customer whose bill groups' derivation and pricing parameters you want to define.

In addition, it contains the following fields in a grid:

Field Name	Field Description	Mandatory (Yes or No)
Source System	Used to indicate the source system from where the claim and enrollment transactions are received.	Yes
Parameter 1	Used to specify the employee attribute based on which you want to derive the bill group. <b>Note:</b> You must not specify the ampersand (&) character in this field.	Yes
Parameter 2	Used to specify the employee attribute based on which you want to derive the bill group. <b>Note:</b> You must not specify the ampersand (&) character in this field.	No
Parameter 3	Used to specify the employee attribute based on which you want to derive the bill group. <b>Note:</b> You must not specify the ampersand (&) character in this field.	No

Field Name	Field Description	Mandatory (Yes or No)
Parameter 4	Used to specify the employee attribute based on which you want to derive the bill group.  <b>Note:</b> You must not specify the ampersand (&) character in this field.	No
Effective Date	Used to specify the date from when the derivation and pricing parameters are effective for the bill group and sort ID combination.  <b>Note:</b> The effective date must be within the date range of the sort ID defined for the bill group.	Yes
Status	Indicates the status of the derivation and pricing parameters for the bill group and sort ID combination. The valid values are:  <ul style="list-style-type: none"> <li>Active</li> <li>Inactive</li> </ul> <b>Note:</b> By default, the value is set to <b>Active</b> .	Not applicable
Bill Group Information	Used to indicate the bill group for whom you want to define the derivation and pricing parameters.  <b>Note:</b> The values appear in this list only when there are effective child persons whose person type is set to <b>Bill Group</b> and who are related to the parent customer using a relationship type which is specified in the <b>Person Relationship Type</b> parameter of the <b>C1-ASOBLNG</b> feature configuration.	Yes
Sort ID	Used to indicate the sort ID of the bill group for which you want to define the derivation and pricing parameters.  <b>Note:</b> The <b>Search</b> (🔍) icon appears corresponding to this field. On clicking the <b>Search</b> icon, the <b>Sort ID Search</b> window appears.	Yes

- Enter the required details in the grid.
- If you want to define the derivation and pricing parameters for more than one bill group and sort ID combination, click the **Add** (📄+) icon and then repeat step 5.

**Note:** However, if you want to remove the derivation and pricing parameters of a bill group and sort ID combination, click the **Delete** (🗑️) icon corresponding to the bill group and sort ID combination.

- Click **Save**.

The derivation and pricing parameters are defined for the bill group and sort ID combination.

### Related Topics

For more information on...	See...
How to search for a person	<a href="#">Searching for a Person</a> on page 185
<b>Customer 360° Information</b> screen	<a href="#">Customer 360° Information</a> on page 196
<b>Person</b> tab	<a href="#">Customer 360° Information - Person</a> on page 201
<b>Bill Group Derivation and Pricing Parameters</b> zone	<a href="#">Bill Group Derivation and Pricing Parameters</a> on page 208
How to setup the <b>C1-ASOBLNG</b> feature configuration	<a href="#">Setting the C1-ASOBLNG Feature Configuration</a> on page 2889

## Editing the Derivation and Pricing Parameters of a Bill Group and Sort ID Combination

### Procedure

To edit the derivation and pricing parameters of a bill group and sort ID combination:

1. Search for a person whose person type is set to **Parent Customer** in the **Customer 360° View** screen.
2. In the **Search Results** section, click the **View** () icon corresponding to the person whose details you want to view.

The **Person** tab appears in the **Customer 360° Information** screen.

3. Expand the **Bill Group Derivation and Pricing Parameters** zone.

**Note:** The **Bill Group Derivation and Pricing Parameters** zone appears when you are viewing the 360° information of a person whose person type is set to **Parent Customer**.

4. In the **Bill Group Derivation and Pricing Parameters** zone, select the check box corresponding to the bill group and sort ID combination whose details you want to edit.

**Note:** If you want to edit the derivation and pricing parameters of all bill group and sort ID combinations, you need to select the check box corresponding to the column header. In such case, the system considers only those records which are present on the respective page for editing.

5. Click **Edit**.

The **Bill Group Derivation and Pricing Parameters** screen appears. It contains the following field:

Field Name	Field Description
Parent Customer	Indicates the parent customer whose bill groups' derivation and pricing parameters you want to edit.

In addition, it contains the following fields in a grid:

Field Name	Field Description	Mandatory (Yes or No)
Source System	Indicates the source system from where the claim and enrollment transactions are received.	Not applicable
Parameter 1	Indicates the employee attribute based on which you want to derive the bill group.	Not applicable
Parameter 2	Indicates the employee attribute based on which you want to derive the bill group.	Not applicable

Field Name	Field Description	Mandatory (Yes or No)
Parameter 3	Indicates the employee attribute based on which you want to derive the bill group.	Not applicable
Parameter 4	Indicates the employee attribute based on which you want to derive the bill group.	Not applicable
Effective Date	Displays the date from when the derivation and pricing parameters are effective for the bill group and sort ID combination.	Not applicable
Status	Used to indicate the status of the derivation and pricing parameters for the bill group and sort ID combination. The valid values are: <ul style="list-style-type: none"> <li>• Active</li> <li>• Inactive</li> </ul>	Yes
Bill Group Information	Indicates the bill group for whom the derivation and pricing parameters are defined.	Not applicable
Sort ID	Indicates the sort ID of the bill group for which the derivation and pricing parameters are defined.	Not applicable

- If required, you can inactivate the derivation and pricing parameters of a bill group and sort ID combination.
- Click **Save**.

The changes made to the derivation and pricing parameters of a bill group and sort ID combination are saved.

### **Related Topics**

For more information on...	See...
How to search for a person	<a href="#">Searching for a Person</a> on page 185
<b>Customer 360° Information</b> screen	<a href="#">Customer 360° Information</a> on page 196
<b>Person</b> tab	<a href="#">Customer 360° Information - Person</a> on page 201
<b>Bill Group Derivation and Pricing Parameters</b> zone	<a href="#">Bill Group Derivation and Pricing Parameters</a> on page 208

## **Creating a Bill Group Derivation and Pricing Parameters Upload Request**

### **Procedure**

To create a bill group derivation and pricing parameters upload request:

- Search for a person whose person type is set to **Parent Customer** in the **Customer 360° View** screen.
- In the **Search Results** section, click the **View** () icon corresponding to the person whose details you want to view.

The **Person** tab appears in the **Customer 360° Information** screen.

- Expand the **Bill Group Derivation and Pricing Parameters** zone.

**Note:** The **Bill Group Derivation and Pricing Parameters** zone appears when you are viewing the 360° information of a person whose person type is set to **Parent Customer**.

- Click the **Upload** link in the upper right corner of the **Bill Group Derivation and Pricing Parameters** zone.



The **Select Upload Request Type** screen appears. It contains the following field:

Field Name	Field Description	Mandatory (Yes or No)
Upload Request Type	Used to indicate the upload request type using which you want to create the upload request.  <b>Note:</b> The list includes only those upload request types where the upload request business object with the <b>Upload Type</b> option type set to <b>BL</b> is selected.	Yes

**Note:** The **Select Upload Request Type** screen appears only when there are multiple upload request types where the upload request business object with the **Upload Type** option type set to **BL** is selected. If there is only one such upload request type defined in the application, the **Bill Group Derivation and Pricing Parameters Upload Request** screen appears.

5. Select the required upload request type from the respective field.
6. Click **OK**.

The **Bill Group Derivation and Pricing Parameters Upload Request** screen appears. It contains the following sections:

- **Main** – Used to specify basic details about the upload request.
- **Characteristics** – Used to define characteristics for the upload request.

The **Main** section contains the following fields:

Field Name	Field Description	Mandatory (Yes or No)
Upload Request Type	Indicates the upload request type using which the bill group derivation and pricing parameters upload request will be created.	Not applicable
Parent Customer	Used to indicate the person for whom you want to create the bill group derivation and pricing parameters upload request.  <b>Note:</b> By default, the parent customer's ID appears in this field. You can change the person, if required.  The system allows you to create a bill group derivation and pricing parameters upload request for a person whose person type is set to <b>Parent Customer</b> .  The <b>Search</b>  icon appears corresponding to this field. On clicking the <b>Search</b> icon, the <b>Person Search</b> window appears.	Yes

Field Name	Field Description	Mandatory (Yes or No)
File Name	Used to specify the name and path of the file that you want to upload.  <b>Note:</b> You can also click the <b>Browse</b> button corresponding to this field to browse to the location where the file is available in the system.	Yes
Replace Existing File	Used to indicate whether you want to replace any existing file in the system. You must select this check box when you want to upload the same file once again.	No
Comments	Used to specify additional information about the upload request.	No

- Click the **Browse** button corresponding to the **File Name** field.

The **Choose File to Upload** dialog box appears.

- Browse to the location where the file that you want to upload is available in the system.

- Click **Open**.

The file name along with the path appears in the **File Name** field.

- Select the **Replace Existing File** check box depending on whether you want to upload the same file once again in the system.

- Define characteristics for the upload request, if required.

- Click **Save**.

A message appears indicating the number of records which are successfully uploaded. Then, a bill group derivation and pricing parameters upload request is created in the **Draft** status. If the bill group ID is available in the record, the status of the record is set to **Pending**. However, if the system could not derive the bill group ID using the bill group identifier type and bill group identifier combination when the bill group ID is not specified in the record, the status of the record is set to **Invalid**.

### **Related Topics**



For more information on...	See...
How to search for a person	<a href="#">Searching for a Person</a> on page 185
<b>Customer 360° Information</b> screen	<a href="#">Customer 360° Information</a> on page 196
<b>Person</b> tab	<a href="#">Customer 360° Information - Person</a> on page 201
<b>Bill Group Derivation and Pricing Parameters</b> zone	<a href="#">Bill Group Derivation and Pricing Parameters</a> on page 208
How to define characteristics for an upload request	<a href="#">Defining Characteristics for an Upload Request</a> on page 1663

## **Viewing the Pricing Rules Defined for a Policy of a Bill Group**

### **Procedure**

To view the pricing rules defined for a policy of a bill group:

- Search for a bill group whose is associated with a self-funded policy in the **Customer 360° View** screen.

2. In the **Search Results** section, click the **View** () icon corresponding to the bill group whose details you want to view.  
The **Person** tab appears in the **Customer 360° Information** screen.
3. Click the **Pricing** tab.  
The **Pricing** tab appears.
4. In the **Bill Group ASO Policy Information** zone, click the **Broadcast** () icon corresponding to a bill group and policy combination whose details you want to view.  
The **Bill Group ASO Policy Pricing Rules** and **Bill Group Pricing Groups** zones appear.
5. View the pricing rules which are defined for the policy of the bill group in the **Bill Group ASO Policy Pricing Rules** zone.



### Related Topics

For more information on...	See...
How to search for a person	<a href="#">Searching for a Person</a> on page 185
<b>Customer 360° Information</b> screen	<a href="#">Customer 360° Information</a> on page 196
<b>Pricing</b> tab	<a href="#">Customer 360° Information - Pricing</a> on page 229
<b>Bill Group ASO Policy Information</b> zone	<a href="#">Bill Group ASO Policy Information</a> on page 236
<b>Bill Group ASO Policy Pricing Rules</b> zone	<a href="#">Bill Group ASO Policy Pricing Rules</a> on page 237

## Viewing the Pricing Groups of a Bill Group

### Procedure

To view the pricing groups of a bill group:

1. Search for a bill group whose is associated with a self-funded policy in the **Customer 360° View** screen.
2. In the **Search Results** section, click the **View** () icon corresponding to the bill group whose details you want to view.  
The **Person** tab appears in the **Customer 360° Information** screen.
3. Click the **Pricing** tab.  
The **Pricing** tab appears.
4. In the **Bill Group ASO Policy Information** zone, click the **Broadcast** () icon corresponding to a bill group whose pricing groups you want to view.  
The **Bill Group ASO Policy Pricing Rules** and **Bill Group Pricing Groups** zones appear.
5. View the pricing groups which are defined for the bill group and are currently active in the **Bill Group Pricing Groups** zone.

### Related Topics

For more information on...	See...
How to search for a person	<a href="#">Searching for a Person</a> on page 185
<b>Customer 360° Information</b> screen	<a href="#">Customer 360° Information</a> on page 196
<b>Pricing</b> tab	<a href="#">Customer 360° Information - Pricing</a> on page 229

For more information on...	See...
<b>Bill Group ASO Policy Information</b> zone	<a href="#">Bill Group ASO Policy Information</a> on page 236
<b>Bill Group Pricing Groups</b> zone	<a href="#">Bill Group Pricing Groups</a> on page 242

## Renewing a Self-Funded Policy of a Bill Group

Oracle Revenue Management and Billing enables you to renew a self-funded policy which is associated with a bill group. However, note that you can renew a self-funded policy only when it is in the **In Force/Active** status and is not yet renewed. For more information, see [Self-Funded Policy Renewal](#) on page 2041.

### Procedure

To renew a self-funded policy of a bill group:

1. Search for the bill group who is associated with the self-funded policy (which you want to renew) in the **Customer 360° View** screen.

2. In the **Search Results** section, click the **View** () icon corresponding to the bill group whose details you want to view.

The **Person** tab appears in the **Customer 360° Information** screen.

3. Click the **Pricing** tab.

The **Pricing** tab appears.

4. In the **Bill Group ASO Policy Information** zone, click the **Renew** () icon in the **Renew** column corresponding to the self-funded policy which you want to renew.

The **Policy** screen appears. It contains the following sections:

- **Main** - Used to specify basic details about the renewed policy.
- **Persons** - Used to associate or disassociate persons from the renewed policy.

**Note:** You cannot disassociate persons who are associated with the base policy using a policy person role which is specified in the **Bill Group Policy Person Role** or **Parent Customer Policy Person Role** option type of the **C1-ASOBLNG** feature configuration.

- **Characteristics** - Used to define characteristics for the renewed policy.

The **Main** section contains the following fields:

Field Name	Field Description	Mandatory (Yes or No)
Base Policy Information	Indicates the policy which you want to renew.	Not applicable
Policy Type	Indicates the policy type using which the base policy is created.	Not applicable
Policy Number	Used to specify the policy number of the renewed policy.	Yes
Description	Used to specify the description for the renewed policy.	Yes

Field Name	Field Description	Mandatory (Yes or No)
Start Date	<p>Used to specify the date from when the renewed policy is effective.</p> <div data-bbox="537 289 1182 632" style="border: 1px solid black; padding: 5px;"> <p><b>Note:</b></p> <p>By default, the start date is set to the base policy's end date plus one day. For example, if the base policy's end date is 12-31-2018, then by default, the renewed policy's start date is set to 01-01-2019.</p> <p>The start date cannot be later than the end date.</p> <p>The start date cannot be earlier than or equal to the base policy's end date.</p> </div>	Yes
End Date	<p>Used to specify the date till when the renewed policy is effective.</p> <div data-bbox="537 737 1182 789" style="border: 1px solid black; padding: 5px;"> <p><b>Note:</b> The end date cannot be earlier than the start date.</p> </div>	Yes
Runout End Date	<p>Used to specify the date when the runout period of the renewed policy ends.</p> <div data-bbox="537 898 1182 978" style="border: 1px solid black; padding: 5px;"> <p><b>Note:</b> The runout end date cannot be earlier than or equal to the renewed policy's end date.</p> </div>	No
Runout Administration Fees	<p>Used to indicate whether the administration fees must be charged when the claim transaction for the policy is processed in the runout period. The valid values are:</p> <ul style="list-style-type: none"> <li>• None</li> <li>• Percentage of Claim</li> </ul> <div data-bbox="537 1220 1182 1360" style="border: 1px solid black; padding: 5px;"> <p><b>Note:</b> At present, this field is used only for the informational purposes and is not considered during the billable charge creation for the claim transactions which are received in the runout period of the policy.</p> </div>	No

Field Name	Field Description	Mandatory (Yes or No)
Copy Pricing Rules	<p>Used to indicate whether you want to copy the pricing rules of the base policy to the renewed policy. If you select the <b>Copy Pricing Rules</b> option, the system copies the following pricing rules of the base policy:</p> <ul style="list-style-type: none"> <li>• Claim</li> <li>• Retention Type Claim Based</li> <li>• Retention Type Enrollment Based</li> <li>• Recurring Flat Fees</li> <li>• Ancillary</li> </ul> <div style="border: 1px solid black; padding: 5px; margin-top: 10px;"> <p><b>Note:</b></p> <p>While copying a pricing rule, the start and end dates of the new pricing rule are set to the renewed policy's start and end dates, respectively.</p> <p>If there are multiple pricing rules which are created using the same pricing rule type and are effective for the different date range, the system copies only one pricing rule from the base policy with the latest date range.</p> </div>	No

**Note:** The **Renew** icon appears only when the policy is in the **In Force/Active** status and it is not yet renewed.

5. Enter the required details in the **Main** section.
6. Associate or disassociate persons from the renewed policy, if required.
7. Define, edit, or remove characteristics from the renewed policy, if required.
8. Click **Save**.

The renewed policy is created in the **Pending** status. The renewal date is stamped corresponding to the base policy in the **Bill Group ASO Policy Information** zone.

### Related Topics

For more information on...	See...
How to search for a person	<a href="#">Searching for a Person</a> on page 185
<b>Customer 360° Information</b> screen	<a href="#">Customer 360° Information</a> on page 196
<b>Pricing</b> tab	<a href="#">Customer 360° Information - Pricing</a> on page 229
<b>Bill Group ASO Policy Information</b> zone	<a href="#">Bill Group ASO Policy Information</a> on page 236
How to associate a person with a policy	<a href="#">Associating a Person with a Policy</a> on page 2092
How to define a characteristic for a policy	<a href="#">Defining a Characteristic for a Policy</a> on page 2093
How to setup the <b>C1-ASOBLLNG</b> feature configuration	<a href="#">Setting the C1-ASOBLLNG Feature Configuration</a> on page 2889

## Viewing the Bill Details

### Procedure

To view the details of a bill:

1. Search for the account, whose bill details you want to view, in the **Customer 360° View** screen.
2. In the **Search Results** section, click the **View** () icon corresponding to the account whose details you want to view.

The **Account** tab appears in the **Customer 360° Information** screen.

3. In the **Open Bills** zone, click the **View** () icon corresponding to the bill whose details you want to view.

The **Bill Information** screen appears. It contains the following zones:

- [Bill Information](#) on page 265
  - [Adjustments](#) on page 265
  - [Settlement Activities](#) on page 265
  - [Bill Segment Summary](#) on page 266
  - [Bill Segment Details](#) on page 266
  - [Hold Details](#) on page 267
  - [Offset Details](#) on page 268
  - [Refund and Write Off Details](#) on page 268
4. View the basic details about the bill in the **Bill Information** zone.
  5. View the adjustments which are swept onto the bill in the **Adjustments** zone.
  6. View the activities, such as payment, transfer, offset, refund, or write off through which the bill is settled, in the **Settlement Activities** zone.
  7. View the bill segment information which is summarized based on the coverage period and plan/fee type combination in the **Bill Segment Summary** zone.
  8. View the details of the bill segments which are included in the bill in the **Bill Segment Details** zone.
  9. View the active hold requests due to which the bill is kept on hold in the **Hold Details** zone.
  10. View the offset requests through which the bill is offset against another bill in the **Offset Details** zone.
  11. View the refund and write off requests through which the bill or its bill segment is either refunded or written off in the **Refund and Write Off Details** zone.



#### Related Topics

For more information on...	See...
How to search for an account	<a href="#">Searching for an Account</a> on page 186
<b>Customer 360° Information</b> screen	<a href="#">Customer 360° Information</a> on page 196
<b>Account</b> tab	<a href="#">Customer 360° Information - Account</a> on page 212
<b>Open Bills</b> zone	<a href="#">Open Bills</a> on page 219
<b>Bill Information</b> screen	<a href="#">Bill Information</a> on page 264

## Viewing the Pricing Rules Defined for a Policy Plan

### Procedure

To view the pricing rules defined for a policy plan:

1. Search for a person who is associated with a fully-insured policy in the **Customer 360° View** screen.
2. In the **Search Results** section, click the **View** () icon corresponding to the person whose details you want to view.  
The **Person** tab appears in the **Customer 360° Information** screen.
3. Click the **Pricing** tab.  
The **Pricing** tab appears.
4. In the **Policy Plan Information** zone, click the **Broadcast** () icon corresponding to a policy plan whose details you want to view.  
The **Policy Plan Pricing Rules** zone appears.
5. View the pricing rules which are defined for the policy plan in the **Policy Plan Pricing Rules** zone.

**Tip:** Alternatively, you can access the **Policy Plan Pricing Rules** zone by clicking the **View** () icon corresponding to a policy plan in the **Policy Plans** zone of the **Policy** tab.

### Related Topics

For more information on...	See...
How to search for a person	<a href="#">Searching for a Person</a> on page 185
<b>Customer 360° Information</b> screen	<a href="#">Customer 360° Information</a> on page 196
<b>Pricing</b> tab	<a href="#">Customer 360° Information - Pricing</a> on page 229
<b>Policy Plan Information</b> zone	<a href="#">Policy Plan Information</a> on page 245
<b>Policy Plan Pricing Rules</b> zone	<a href="#">Policy Plan Pricing Rules</a> on page 246

## Bill Information

The **Bill Information** screen allows you to view:

- Basic details of the bill
- Adjustments which are swept onto the bill
- Activities, such as payment, offset, refund, write off, or transfer through which the bill is settled
- High-level summary and details of the bill segments which are included in the bill
- Active hold requests due to which the bill is kept on hold
- Offset requests through which the bill is offset against another bill
- Refund and write off requests through which the bill or its bill segment is either refunded or written off

It contains the following zones:

- [Bill Information](#) on page 265
- [Adjustments](#) on page 265
- [Settlement Activities](#) on page 265
- [Bill Segment Summary](#) on page 266
- [Bill Segment Details](#) on page 266
- [Hold Details](#) on page 267



- [Offset Details](#) on page 268
- [Refund and Write Off Details](#) on page 268

## Bill Information

The **Bill Information** zone displays the details of the bill. It contains the following section:

- **Main** - Displays the basic information about the bill. It contains the following fields:

Field Name	Field Description
Bill Information	<p>Displays information about the bill. In addition, a context menu appears corresponding to this field which helps in navigating to other screens in the application.</p> <p><b>Note:</b> It has a link. On clicking the link, the <b>Bill</b> screen appears where you can view the details of the respective bill.</p>
Alternate Bill ID	<p>Displays the alternate bill ID.</p> <p><b>Note:</b> This field appears only when the respective data is available for the bill.</p>
Account Information	<p>Indicates the account for which the bill is generated. In addition, a context menu appears corresponding to this field which helps in navigating to other screens in the application.</p> <p><b>Note:</b> It has a link. On clicking the link, the <b>Account</b> screen appears where you can view the details of the respective account.</p>

## Adjustments

The **Adjustments** zone lists the adjustments which are swept onto the bill. It contains the following columns:

Column Name	Column Description
Adjustment Information	<p>Displays information about the adjustment.</p> <p><b>Note:</b> It has a link. On clicking the link, the <b>Adjustment</b> screen appears where you can view the details of the respective adjustment.</p>
Contract Information	<p>Indicates the contract against which the adjustment is created. In addition, this column has a context menu which helps in navigating to other screens in the application.</p> <p><b>Note:</b> It has a link. On clicking the link, the <b>Contract</b> screen appears where you can view the details of the respective contract.</p>

## Settlement Activities

You may settle a bill or its bill segment by making a payment, offsetting, refunding, writing off, or by reconciling against pay instructions. The **Settlement Activities** zone lists the activities related to the bill or its bill segment settlement. It contains the following columns:

Column Name	Column Description
Activity Date	Displays the date when the settlement activity was performed in the system.

Column Name	Column Description
Activity Type	Indicates the type of the settlement activity. The valid values are: <ul style="list-style-type: none"> <li>• Payment</li> <li>• Offset</li> <li>• Refund</li> <li>• Write Off</li> <li>• Transfer</li> </ul>
Amount	Indicates the amount settled through the activity.
Related Object Information	Displays additional information about the settlement activity.
Related Object ID	Indicates the payment, offset request, refund request, write off request, or reconciliation adjustment which is created during settlement. <div style="border: 1px solid black; padding: 5px; margin-top: 10px;"> <p><b>Note:</b> It has a link. On clicking the link, the <b>Payment, Offset Request, Refund Request, Write Off Request, or Adjustment</b> screen appears where you can view the details of the respective activity.</p> </div>

## Bill Segment Summary

The system groups the bill segments with the same date range and plan/fee type combination and then provides the summarized information for each combination in the **Bill Segment Summary** zone. It contains the following columns:

Column Name	Column Description
Start Date	Displays the start date of the bill segment.
End Date	Displays the end date of the bill segment.
Policy Number	Indicates the policy for which the bill segment is generated.
Plan/Fee Type	Indicates the plan code or fee type for which the bill segment is generated.
Amount	Displays the bill segment amount.
Unpaid Amount	Displays the unpaid amount of the bill segment.

**Note:** Pagination is used to display limited number of records in this zone. You can use the navigation links, such as **Previous** and **Next** to navigate between pages.

## Bill Segment Details

The **Bill Segment Details** zone displays the details of the bill segments which are included in the bill. It contains the following columns:

Column Name	Column Description
Start Date	Displays the start date of the bill segment.
End Date	Displays the end date of the bill segment.
Policy Number	Indicates the policy for which the bill segment is generated.
Plan/Fee Type	Indicates the plan code or fee type for which the bill segment is generated.
External Membership ID	Indicates the membership in which the member is included.

Column Name	Column Description
Member Primary ID	Displays the concatenated string consisting of primary identifier type and primary identifier of the member which are separated by a colon (:).
Member Name	Indicates the member for whom the bill segment is generated.
Coverage Tier	Indicates the coverage tier to which the membership belongs. The valid values are: <ul style="list-style-type: none"> <li>CHILDREN ONLY</li> <li>EMPLOYEE &amp; CHILD(REN)</li> </ul> <div style="border: 1px solid black; padding: 2px; margin-top: 5px;"> <b>Note:</b> The data appears in this column only when the <b>Coverage Tier (C1CVTIER)</b> characteristic type is defined for the membership. </div>
Status	Indicates the eligibility status of the member. The valid values are: <ul style="list-style-type: none"> <li>Active</li> <li>Cobra</li> <li>Retiree</li> <li>Terminated</li> </ul> <div style="border: 1px solid black; padding: 2px; margin-top: 5px;"> <b>Note:</b> The data appears in this column only when the <b>Eligibility Status Type (C1ELGSTA)</b> characteristic type is defined for the member. </div>
Amount	Displays the bill segment amount.
Unpaid Amount	Displays the unpaid amount of the bill segment.

**Note:** Pagination is used to display limited number of records in this zone. You can use the navigation links, such as **Previous** and **Next** to navigate between pages.

On clicking the **View** () icon corresponding to a bill segment, the **Bill Segment** screen appears where you can view the additional details of the respective bill segment.

You can filter the list using various search criteria (such as, **Start Date** and **End Date**) available in the **Filter** area.

By default, the **Filter** area is hidden. You can view the **Filter** area by clicking the **Filters** () icon in the upper right corner of this zone.

## Hold Details

The **Hold Details** zone lists the active hold requests due to which the bill is kept on hold. It contains the following columns:

Column Name	Column Description
Hold Request Information	Displays information about the hold request. <div style="border: 1px solid black; padding: 2px; margin-top: 5px;"> <b>Note:</b> It has a link. On clicking the link, the <b>Hold Request</b> screen appears where you can view the details of the respective hold request. </div>
Status	Indicates the status of the hold request.

Column Name	Column Description
Entity	Indicates the type of the entity. The valid values are: <ul style="list-style-type: none"> <li>• Person</li> <li>• Account</li> <li>• Bill</li> </ul>
Entity Information	Indicates the entity for which the hold request is created. In addition, this column has a context menu which helps in navigating to other screens in the application. <div style="border: 1px solid black; padding: 5px; margin-top: 10px;"> <p><b>Note:</b> It has a link. On clicking the link, the <b>Person, Account, or Bill</b> screen appears where you can view the details of the respective entity.</p> </div>
Start Date	Displays the date from when the entity is kept on hold.
End Date	Displays the date till when the entity is kept on hold.

**Note:** Pagination is used to display limited number of records in this zone. You can use the navigation links, such as **Previous** and **Next** to navigate between pages.

## Offset Details

The **Offset Details** zone lists the offset requests through which the bill is offset against another bill. It contains the following columns:

Column Name	Column Description
Offset Request Information	Displays information about the offset request. <div style="border: 1px solid black; padding: 5px; margin-top: 10px;"> <p><b>Note:</b> It has a link. On clicking the link, the <b>Offset Request</b> screen appears where you can view the details of the respective offset request.</p> </div>
Offset Amount	Indicates the bill amount which is offset against another bill.
Creation Mode	Indicates the mode in which the offset request is created. The valid values are: <ul style="list-style-type: none"> <li>• Automatic</li> <li>• Manual</li> </ul>

**Note:** Pagination is used to display limited number of records in this zone. You can use the navigation links, such as **Previous** and **Next** to navigate between pages.

## Refund and Write Off Details

The **Refund and Write Off Details** zone lists the refund and write off requests through which the bill or its bill segment is either refunded or written off. It contains the following columns:

Column Name	Column Description
Create Date/Time	Displays the date and time when the refund or write off request is created.

Column Name	Column Description
Refund/Write Off Request Information	Displays information about the refund or write off request.  <b>Note:</b> It has a link. On clicking the link, the <b>Refund Request</b> or <b>Write Off Request</b> screen appears depending on whether the request is created for refund or write off.
Refund/Write Off Amount	Displays the total refund or write off amount.
Status	Indicates the status of the refund or write off request. The valid values are: <ul style="list-style-type: none"> <li>• Approval In Progress</li> <li>• Cancelled</li> <li>• Deferred Processing</li> <li>• Draft</li> <li>• Processed</li> <li>• Rejected</li> <li>• Voided</li> </ul>
Action	Indicates whether the request is created for refund or write off. The valid values are: <ul style="list-style-type: none"> <li>• Refund</li> <li>• Write Off</li> </ul>
Account Information	Indicates the account for which the refund or write off request is created. In addition, this column has a context menu which helps in navigating to other screens in the application.  <b>Note:</b> It has a link. On clicking the link, the <b>Account</b> screen appears where you can view the details of the respective account.
Created By	Indicates the user who has created the refund or write off request.

**Note:** Pagination is used to display limited number of records in this zone. You can use the navigation links, such as **Previous** and **Next** to navigate between pages.

You can filter the list using the **Action** field available in the **Filter** area. By default, the **Filter** area is hidden. You can view the **Filter** area by clicking the **Filters** (  ) icon in the upper right corner of this zone.



---

# Chapter 5

---

## Pricing Management

---

### Topics:

- [Types of Pricing](#)
- [Multi Parameter Based Pricing](#)
- [Price Assignment Search Mechanism](#)
- [Person Relationship Type Sequence](#)
- [Pricing Eligibility](#)
- [Persisting Interest Rate for Rate Type Price Items](#)
- [Persisting Fee for Fee Type Price Items](#)
- [Repricing](#)
- [Two-Dimensional Pricing](#)
- [Types of Price Item Bundle](#)
- [Parameter](#)
- [Price Item](#)
- [Price List](#)
- [Pricing \(Account\)](#)
- [Pricing \(Person\)](#)
- [Price Item Pricing \(Used for Viewing\)](#)
- [Pricing Simulation](#)
- [Eligible Price List](#)
- [Rate Definition](#)
- [Tiering Criterion](#)
- [Variance Parameter](#)
- [Person to Person Relationship Type Sequence](#)
- [Multiple Parameter Based Post-Processing Pricing](#)

Oracle Revenue Management and Billing allows you to define prices for price item and services offered to the customers. These prices are either standard prices defined in the price lists or override prices that are specific to a customer or an account. The system allows you to define prices at various levels in a customer hierarchy (for example, at the account level, main customer level, or at the parent customer level). You can also define prices in the account's price list, main customer's price list, parent customer's price list, price list's parent price list. As prices can be defined at multiple places, the order in which the system searches for effective price item pricing will affect the price charged to the customer. The search order is configurable, and can vary with each division. You need to define the search order in the price assignment search algorithm (which is also known as crawling algorithm) and then attach the algorithm to the division. You can change the search order at any time.

You need to define the price assignment search algorithm using the C1\_PRASN algorithm type. The price assignment search algorithm is used while:

- Listing effective price item pricing for an account or a customer
- Fetching effective price item pricing while creating recurring and non-recurring bill segments
- Fetching effective post processing pricing while creating post processing bill segments
- Fetching effective price item pricing in the **Price Item Pricing Verification (C1-TXNVP)** batch

For more information about the price assignment search algorithm, see [Price Assignment Search Mechanism](#) on page 277.

Since a global customer is not associated to any division, the system cannot determine the price assignment search order for a global customer. Hence, the default search order is defined for global customers through the **C1\_PRASNORDR** feature configuration. You can change this default search order, if required.

The prices that are specific to a customer or an account are referred to as customer agreed or account agreed prices, respectively. You can override these agreed prices. Customer agreed or account agreed prices are effective for a particular duration and do not expire until you manually specify the end date. However, if you set the **Expire Override Switch** option type of the **C1\_EXP\_OVRD** feature configuration to **Y**, the system will automatically expire an agreed pricing when the agreed pricing of a customer or an account without end date is overridden. If you do not want an agreed pricing to automatically expire when it is overridden, you must set the **Expire Override Switch** option type of the **C1\_EXP\_OVRD** feature configuration to **N**.

The system allows you to define the following types of pricing:

- Flat Pricing
- Tiered Pricing

For more information about the types of pricing, see [Types of Pricing](#) on page 273.

The price for a price item or service may differ depending upon various transaction, customer or account attributes. Oracle Revenue Management and Billing provides a facility to define pricing for a price item based on multiple parameters. This multi parameter based pricing feature enables the price analyst to define price item and its parameters which influence pricing. You can then define pricing for the price item based on these parameters. Bundles are offered to customers to provide discounted rates. You can also define pricing for bundles based on multiple parameters. To enable the multi parameter based pricing feature, you must set the **Multi Price Parameter** option type of the **Multi Parameter Based Pricing (C1\_PPARM\_FLG)** feature configuration to **True**. For more information about the multi parameter based pricing feature, see [Multi Parameter Based Pricing](#) on page 273.



## Types of Pricing

The system allows you to define the following types of pricing:

- **Flat Pricing** — Used when you want to charge a fixed price per unit to the customer.
- **Tiered Pricing** — Used when standard flat pricing is not sufficient to meet the business needs. Through tiered pricing, you can offer more favorable pricing to the customers based on service quantity utilization. For example, CG Limited uses wire transfer services provided by a large bank. If CG Limited initiates up to 1,000 wire transfers, the fee charged by the bank will be \$5 per transfer. If CG Limited initiates more than 1,000 wire transfers, the fee will be \$3 per transfer. To introduce this flexibility in the pricing model, the following tiered pricing is defined:

Quantity Range	Rate (\$) per transfer
0 – 1000	5
1000+	3

You can define two types of tiered pricing:

- **Step Tiered Pricing** — The rate of the first tiering range is used to calculate the charge for the maximum quantity in the range, and for incremental service quantity utilization, the rate of the progressive tiering range is used. This happens till the utilized quantity is exhausted. For example, when you define the following step tiered pricing for Price Item A and the user consumes 60,000 units of the same, the system will charge the first 45,000 units at \$2 per unit and the remaining 15,000 units at \$1 per unit:

Quantity Range	Rate (\$) per unit
0 – 45000	2
45000+	1

- **Threshold Tiered Pricing** — The rate of the tiering range within which the service quantity utilization falls is used to calculate the charge for the entire volume. For example, when you define the following threshold tiered pricing for Price Item A and the user consumes 75,000 units of the same, the system will charge 75,000 units at \$1 per unit as the service quantity utilization falls within 45000+ tiering range:

Quantity Range	Rate (\$) per unit
0 – 45000	2
45000+	1

## Multi Parameter Based Pricing

Oracle Revenue Management and Billing provides a facility to define pricing for a price item based on multiple parameters. You can also define pricing for bundles based on multiple parameters. You can enable or disable the multi parameter based pricing feature by setting the **Multi Parameter Based Pricing (C1\_PPARM\_FLG)** feature configuration. For more information, see [Setting the C1\\_PPARM\\_FLG Feature Configuration](#) on page 2922.

If the multi parameter based pricing feature is disabled, you can define pricing for a price item based on the variance parameter. If the multi parameter based pricing feature is enabled, you can define pricing for a price item based on multiple parameters. For example:

Price Item A	Country	Currency
Pricing 1	US	USD

Price Item A	Country	Currency
Pricing 2	Germany	USD

Pricing 1 and Pricing 2 are defined for Price Item A based on two parameters — Country and Currency. Before you define pricing based on country and currency, you need to define these parameters in the system. Once you define these parameters, you need to associate them to the price item (i.e. Price item A).

Then, when you define Pricing 1 for Price item A, you need to set the following price item parameters:

- Country — US
- Currency — USD

Similarly, you need to define Pricing 2 with Country set to Germany and Currency set to USD.

The following table lists the tiering ranges defined in Pricing 1 where price item parameters are set to US, USD:

Tier Sequence	Rate	Tiering Criteria	Price Item	Price Parameters	Item	From	To
10	2	Number of Transactions	Price Item A	US, USD		0	5000
20	1	Number of Transactions	Price Item A	US, USD		5000	

The following table lists the tiering ranges defined in Pricing 2 where price item parameters are set to Germany, USD:

Tier Sequence	Rate	Tiering Criteria	Price Item	Price Parameters	Item	From	To
10	4	Number of Transactions	Price Item A	Germany, USD		0	1000
20	3	Number of Transactions	Price Item A	Germany, USD		1000	

Now, when the user performs 1500 transactions (in USD) of Price Item A in Germany, 12000 transactions (in USD) of Price Item A in US, the system creates two billable charges. In one billable charge (with Price Item A, US and USD combination), the system uses \$1 as the rate for calculating charges, and in another billable charge (with Price Item A, Germany and USD combination), the system uses \$3 as the rate for calculating charges.

Note that in this case the parameters based on which you have defined pricing and tiering ranges are same. You can use different parameters while defining pricing and tiering ranges, if required. You can also use another price item or bundle and its parameters while defining tiering ranges. For example:

The following table lists the tiering ranges of Pricing 1 defined for Price Item A where price item parameters are set to US, USD:

Tier Sequence	Rate	Tiering Criteria	Price Item	Price Parameters	Item	From	To
10	2	Number of Transactions	Price Item B	Germany, USD		0	100
20	1	Number of Transactions	Price Item B	Germany, USD		100	200
30	0.5	Number of Transactions	Price Item B	Germany, USD		200	

Now, when the user performs 1500 transactions (in USD) of Price Item A in US, 200 transactions (in USD) of Price Item B in Germany, the system creates one billable charge. The system adds the transactions with the following combinations and then determines the range of Price Item A within which the total units (i.e. 200) fall:

- Price Item B, Germany, USD

In this case, the total units fall in the 100 – 200 range of Price Item A, and therefore the system uses \$1 as the rate for calculating charges (i.e.  $1500 * 1 = 1500$ ).

Some parameters might be mandatory and some might be optional while defining price item pricing. You can define price item pricing based on these parameters at various levels, such as:

- Account Agreed
- Account Price List
- Account Inherited Price List
- Customer Agreed
- Customer Price List
- Customer Inherited Price List
- Parent Customer Agreed
- Parent Customer Price List
- Parent Customer Inherited Price List
- Default Price List
- Global Price List

As prices can be defined at multiple levels, the system first searches for exact match at all levels (using the search order). If the system finds the exact match at multiple levels, the price assignment at the higher precedence level is considered. Let us understand this with the help of an example.

Pricing 1 is defined for Price Item A with the following parameters at the Account Agreed level:

Parameter	Mandatory (Yes or No)	Priority	Value
Type	Yes	—	BT
Country	No	1	US
Currency	No	2	USD

Pricing 2 is defined for Price Item A with the following parameters at the Parent Customer Agreed level:

Parameter	Mandatory (Yes or No)	Priority	Value
Type	Yes	—	BT
Country	No	1	US
Currency	No	2	USD

Pricing 3 is defined for Price Item A with the following parameters at the Account Price List level:

Parameter	Mandatory (Yes or No)	Priority	Value
Type	Yes	—	BT
Country	No	1	US
Currency	No	2	—

Now, when the user performs transactions (with the type set to BT in US) of Price Item A in USD, the system searches for price with exact match (Type — BT, Country — US, and Currency — USD). The exact match is available at two levels — Account Agreed and Parent Customer Agreed. The system considers the price at the Account Agreed level because this level has higher precedence.

Depending on the search order defined for the division (to which the account belongs), the level with higher precedence changes. Accordingly, the price assignment at the higher precedence level is considered for calculating the charges.

If the system does not find the exact match at any level, it searches for the best fit match at all levels. Let us understand how the best fit match is determined with the help of an example.

Pricing 1 is defined for Price Item A with the following parameters:

Parameter	Mandatory (Yes or No)	Priority	Value
Type	Yes	—	BT
Country	No	1	US
Currency	No	2	-

Pricing 2 is defined for Price Item A with the following parameters:

Parameter	Mandatory (Yes or No)	Priority	Value
Type	Yes	—	BT
Country	No	1	-
Currency	No	2	USD

Pricing 3 is defined for Price Item A with the following parameters:

Parameter	Mandatory (Yes or No)	Priority	Value
Type	Yes	—	BT
Country	No	1	-
Currency	No	2	-

Pricing 4 is defined for Price Item A with the following parameters:

Parameter	Mandatory (Yes or No)	Priority	Value
Type	Yes	—	BT
Country	No	1	US
Currency	No	2	GBP

The system has Pricing 1, Pricing 2, Pricing 3, and Pricing 4 defined for Price Item A. Now, when the user performs transactions (with the type set to BT in US) of Price Item A in USD, the system does not find price with exact match (Type — BT, Country — US, and Currency — USD). Therefore, it searches for the best fit match.

While searching for the best fit match, the system rules out the optional parameter with lowest priority (i.e. Currency) and checks whether the price (with Type — BT and Country — US) is available. If the price is available, the system considers the price as the best fit match. Therefore, in this case, Pricing 1 is considered as the best fit match.

Suppose, if the price (with Type — BT and Country — US) is not available, then the system rules out the optional parameter with next lowest priority (i.e. Country) and checks whether the price (with Type — BT and Currency — USD) is available. If the price is available, the system considers the price as the best fit match. In this case, Pricing 2 would be considered as the best fit match. If the system finds the best fit match with same weight at multiple levels, the price assignment at the higher precedence level is considered.

## Price Assignment Search Mechanism

The price assignment search algorithm searches effective price item pricing based on the following parameters:

- **Search Order** — Used to indicate the order in which the system must search effective price item pricing at various levels in the customer hierarchy. This is a mandatory parameter. The valid values are:

If you select the following value...	Then the effective price item pricing is searched at the following levels in the specified order...
AGREED_PRICELIST	<ol style="list-style-type: none"> <li>1. <b>Account Agreed</b> — Means price item pricing is agreed for the account in the hierarchy.</li> <li>2. <b>Account Price List</b> — Means price item pricing is defined within the price list which is assigned to the account.</li> <li>3. <b>Account Inherited Price List</b> — Means price item pricing is inherited from the hierarchy defined for the price list which is assigned to the account.</li> <li>4. <b>Customer Agreed</b> — Means price item pricing is agreed for the customer in the hierarchy.</li> <li>5. <b>Customer Price List</b> — Means price item pricing is defined within the price list which is assigned to the customer.</li> <li>6. <b>Customer Inherited Price List</b> — Means price item pricing is inherited from the hierarchy defined for the price list which is assigned to the customer.</li> <li>7. <b>Parent Customer Agreed</b> — Means price item pricing is agreed for the parent customer in the hierarchy.</li> <li>8. <b>Parent Customer Price List</b> — Means price item pricing is defined within the price list which is assigned to the parent customer.</li> <li>9. <b>Parent Customer Inherited Price List</b> — Means price item pricing is inherited from the hierarchy defined for the price list which is assigned to the parent customer.</li> </ol>

If you select the following value...	Then the effective price item pricing is searched at the following levels in the specified order...
AGREED_FIRST	<ol style="list-style-type: none"> <li>1. <b>Account Agreed</b> — Means price item pricing is agreed for the account in the hierarchy.</li> <li>2. <b>Customer Agreed</b> — Means price item pricing is agreed for the customer in the hierarchy.</li> <li>3. <b>Parent Customer Agreed</b> — Means price item pricing is agreed for the parent customer in the hierarchy.</li> <li>4. <b>Account Price List</b> — Means price item pricing is defined within the price list which is assigned to the account.</li> <li>5. <b>Account Inherited Price List</b> — Means price item pricing is inherited from the hierarchy defined for the price list which is assigned to the account.</li> <li>6. <b>Customer Price List</b> — Means price item pricing is defined within the price list which is assigned to the customer.</li> <li>7. <b>Customer Inherited Price List</b> — Means price item pricing is inherited from the hierarchy defined for the price list which is assigned to the customer.</li> <li>8. <b>Parent Customer Price List</b> — Means price item pricing is defined within the price list which is assigned to the parent customer.</li> <li>9. <b>Parent Customer Inherited Price List</b> — Means price item pricing is inherited from the hierarchy defined for the price list which is assigned to the parent customer.</li> </ol>

**Note:** In these price assignment search orders, the account agreed level has highest precedence and parent customer inherited price list level has lowest precedence.

- **Default Price List ID** — Used to indicate the default price list. If the effective price item pricing is not available at any level in the customer hierarchy, the system checks whether the default price list is specified in the price assignment search algorithm. If the default price list is specified in the algorithm, the system checks whether effective price item pricing is available in the default price list.
- **Global Price List** — Used to indicate whether the system should consider the price item pricing defined in the global price list. If the effective price item pricing is not available in the default price list or if the default price list is not specified in the price assignment search algorithm, the system checks whether it should consider the price item pricing defined in the global price list. The valid values are:

- Y
- N

Finally, if the effective price item pricing is not available in either default and/or global price list, an error message occurs indicating that the effective price item pricing is not available in the system.

- **Prefer Price Item Over Bundle** — Used to indicate whether to prefer price item, regular bundle, or parent bundle pricing when the price item, regular bundle (to which the price item belongs), and parent (regular) bundle (i.e. to which the regular bundle belongs) are assigned at the same level. The valid values are:

- Y
- N

If the value of the **Prefer Price Item Over Bundle** parameter is set to **Y**, the system first searches whether effective pricing is available for the price item. If the effective pricing is not available for the price item, then the system searches whether effective pricing is available for the regular bundle at the same level. If the effective pricing is not available for the regular bundle, then the system searches whether effective pricing is available for the parent bundle at the same level. However, if the value of the **Prefer Price Item Over Bundle** parameter is set to **N**, the system first searches whether effective pricing is available for the parent bundle. If the effective pricing is not available for the parent bundle, then the system searches whether effective pricing is available for the regular bundle at the same level. If the effective pricing is not available for the regular bundle, then the system searches whether effective pricing is available for the price item at the same level.

- **Person Relationship Type Sequence Algorithm** — Used to attach an algorithm which is defined using the C1-CUSRLALGT algorithm type. The attached algorithm is used while searching effective price item pricing at the parent customer level. It indicates whether the system should search person to person relationship type sequence defined:
  - For the division, price item, and price item parameters combination
  - For the division
  - In the C1\_PER\_REL feature configuration

### Related Topics

For more information on...	See...
Person to Person Relationship Type Sequence	<a href="#">Person Relationship Type Sequence</a> on page 279

## Person Relationship Type Sequence

When the price assignment search algorithm searches effective price item pricing at the parent customer level, the system determines the parent customer's person to person relationship type whose price item pricing should be considered. The person to person relationship type sequence indicates the order in which relationship type should be considered while searching for effective price item pricing at the parent customer level. For example, if a customer has two parents – Parent 1 with the relationship type set to “Subsidiary” and Parent 2 with the relationship type set to “Franchise Owner”, and the following person to person relationship type sequence is defined in the system:

When the price assignment search algorithm searches effective price item pricing at the parent customer level, the system determines the parent customer's person to person relationship type whose price item pricing should be considered. The person to person relationship type sequence indicates the order in which relationship type should be considered while searching for effective price item pricing at the parent customer level. For example, if a customer has two parents – Parent 1 with the relationship type set to “Subsidiary” and Parent 2 with the relationship type set to “Franchise Owner”, and the following person to person relationship type sequence is defined in the system:

Sequence Number	Relationship Type
10	Subsidiary
20	Franchise Owner

In the above example, the system will inherit effective price item pricing (if available) from Parent 1 or within its hierarchy. If the effective price item pricing is not available in the Parent 1 hierarchy, the system will inherit effective price item pricing (if available) from Parent 2 or within its hierarchy. If the effective price item pricing is not available in the Parent 2 hierarchy, an error message occurs indicating that the effective price item pricing is not available.

While searching effective pricing at the parent customer level based on the person to person relationship type sequence, the system will use the depth first search mechanism. Let us understand this with the help of an example.

Person To Person Relationship Type Sequence	
Sequence Number	Relationship Type
10	Subsidiary (S)
20	Branch (B)
30	Franchise Owner (F)

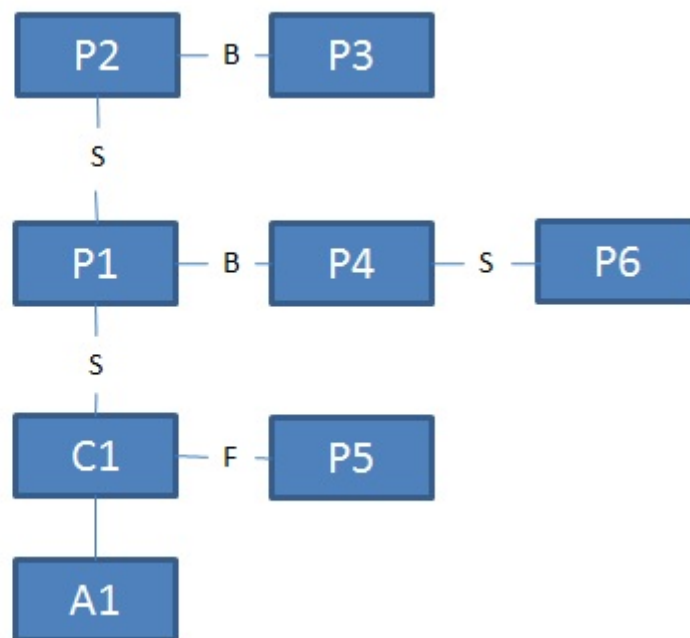

In the above example, if the effective pricing is not available at the account or customer level, the system will search effective pricing at the parent customer level in the following order:

- P1 (because the first relationship type in the sequence is Subsidiary)
- P2 (grandparent of P1 irrespective of the relationship type)
- P3 (because the second relationship type in the sequence is Branch)
- P4 (because the second relationship type in the sequence is Branch)
- P6 (grandparent of P4 irrespective of the relationship type)
- P5 (because the third relationship type in the sequence is Franchise Owner)

The system provides you the flexibility to define person to person relationship type sequence:

- For each division, price item, and price item parameters combination
- For each division
- In the C1\_PER\_REL feature configuration

The system will first check whether the person to person relationship type sequence is defined for the division, price item, and price item parameters combination. If the person to person relationship type sequence is defined for the division, price item, and price item parameters combination, the system will search effective price item pricing at the parent customer level based on the sequence defined for the combination. However, if the person to person relationship type sequence is not defined for the division, price item, and price item parameters combination, the system will check whether the person to person relationship type sequence is defined for the division. If the person to person relationship type sequence is defined for the division, the system will search effective price item pricing at the parent customer level based on the sequence defined for the division. However, if the person to person relationship type sequence is not defined for the division, the system will consider the person to person relationship type sequence defined in the C1\_PER\_REL feature configuration and accordingly search the effective price item pricing at the parent customer level.

To enable the system to search person to person relationship type sequence at different levels, you need to create an algorithm of the C1-CUSRLALGT algorithm type and attach it to the **Person Relationship Type Sequence Algorithm** parameter in the price assignment search algorithm. The C1-CUSRLALGT algorithm type has the following parameters:



- **Check on Division, Price Item and Price Item Parameters Combination** - Used to indicate whether you want the system to search person to person relationship type sequence defined for the division, price item, and price item parameters combination. This is a mandatory parameter. The valid values are:

- Y
- N

By default, the value is set to **N**.

- **Check on Division** - Used to indicate whether you want the system to search person to person relationship type sequence defined for the division. This is a mandatory parameter. The valid values are:

- Y
- N

By default, the value is set to **N**.

- **Check on Feature Configuration** – Used to indicate whether you want the system to consider the person to person relationship type sequence defined in the **C1\_PER\_REL** feature configuration. This is a mandatory parameter. The valid values are:

- **A** – Used when you want to consider all person to person relationship types defined in the feature configuration (in the specified sequence).
- **F** – Used when you want to only consider the person to person relationship type defined with the lowest sequence in the feature configuration.
- **N** – Used when you do not want to consider the person to person relationship type sequence defined in the C1\_PER\_REL feature configuration.

By default, the value is set to **F**.

### Related Topics

For more information on...	See...
<b>Person to Person Relationship Type Sequence</b> screen	<a href="#">Person to Person Relationship Type Sequence</a> on page 598
How to set the C1_PER_REL feature configuration	<a href="#">Setting the C1_PER_REL Feature Configuration</a> on page 2921

## Pricing Eligibility

Oracle Revenue Management and Billing enables you to define pricing eligibility criteria using the account, person, and product attributes while defining a price item pricing. For example, a bank offers a product named 12 Month Standard Certificate of Deposit (CD). The interest rate charged to a person for this product differs based on two parameters – Deposit Amount and Person Type (Preferred and Non-Preferred). The following table lists the interest rates offered for the 12 Month Standard Certificate of Deposit (CD) product:

Deposit Amount	Non-Preferred	Preferred
Less than \$5,000	0.13%	0.20%
Greater than \$5,000	0.15%	0.22%

Earlier, you were able to define different interest rates based on different parameters using the rate eligibility feature at the rate component level. Considering the above example, you had to define four rate components. The respective rate component would appear while defining price item pricing based on the following:

- The value defined for the **Deposit Amount** characteristic on the account

- The value defined for the **Customer Type** characteristic on the main customer

However, now, you can implement the above scenario using a single rate component instead of maintaining four different rate components. Now, while defining price item pricing, you need to define four different price components for a rate component. For each price component, you need to define the pricing eligibility criteria in the following manner:

Price Component	Rate	Pricing Criteria	Eligibility	If True	If False
P1	0.13%	Deposit Amount > 5000		Check Next Condition	Return False
P1	0.13%	Person Type = Non-Preferred		Return True	Return False
P2	0.15%	Deposit Amount < 5000		Check Next Condition	Return False
P2	0.15%	Person Type = Non-Preferred		Return True	Return False
P3	0.20%	Deposit Amount > 5000		Check Next Condition	Return False
P3	0.20%	Person Type = Preferred		Return True	Return False
P4	0.22%	Deposit Amount < 5000		Check Next Condition	Return False
P4	0.22%	Person Type = Preferred		Return True	Return False

You can define pricing eligibility criteria only when the appropriate parameters are created in the system. These parameters must be mapped to either of the following:

- Account attributes, characteristics, usage amounts, or usage counters
- Person attributes, characteristics, usage amounts, or usage counters
- Product attributes or characteristics
- Service Quantity Identifier
- Custom algorithm which returns the appropriate value

In the above example, you can define the pricing eligibility criteria only when the following parameters are defined in the system:

Parameter	Source Entity	Source Type	Source Type Code	Value Type
Deposit Amount	Account	Usage Amount	Deposit Amount	Adhoc
Customer Type	Person	Characteristic	Person Type	Predefined

You can define pricing eligibility criteria for rate components whose tiering type is set to **Flat**, **Threshold**, or **Step**. Each criterion in the pricing eligibility criteria is executed in the specified sequence. If the value of the pricing eligibility criteria is **True**, the rate of the respective price component is passed to the rate component for further calculations.

## Persisting Interest Rate for Rate Type Price Items

While defining a price item, you can indicate whether the price item is available for pricing and billing or only for pricing. If the price item is available only for pricing, you can indicate the type of the price item. The valid values for the price item type are:

- Rate (i.e. Interest Rate)
- Fees

If the type of a price item is **Rate**, the system calculates and persist the rate for the price item. The rate is persisted only for the price item pricing which is either assigned or inherited by an account. If the account or person attributes are changed, the system allows you to recalculate and persist the interest rate for rate type price items. This process is known as **Repricing**.

#### Related Topics

For more information on...	See...
Repricing	<a href="#">Repricing</a> on page 283

## Persisting Fee for Fee Type Price Items

While defining a price item, you can indicate whether the price item is available for pricing and billing or only for pricing. If the price item is available only for pricing, you can indicate the type of the price item. The valid values for the price item type are:

- Rate
- Fees

The input elements Pricing Frequency, Advance Pricing should be populated if **Price Item** is available for **Pricing Only**, **Price Item Type** is **Fees** and **Price Assignment Type** is **Post-Processing**.

If the type of a price item is **Fee**, the system calculates and persist the fee for the price item.

**Note:** The **Process Fees Request and Persist Fees for an Account (C1-ACFEE)** batch is used to calculate and persist the fees for the account. It must be executed when a user wants to store fees.

#### Related Topics

For more information on...	See...
Repricing	<a href="#">Repricing</a> on page 283

## Repricing

If the account or person attributes are changed, the system allows you to recalculate and persist the interest rate for rate type price items. This process is known as **Repricing**. The **Repricing** process is triggered in the following scenarios when:

- You edit the attributes and characteristics of an account.
- You add or delete the usage amount and counter details of an account.
- You edit the attributes and characteristics of a person.
- You add or delete the usage amount and counter details of a person.
- You define or edit the price item pricing of an active price list which is assigned to an account or a person.
- You define, edit, override, or copy the price item pricing of an account or a person.
- You assign a price list to an account or a person, or edit the price list assignment details of an account or a person.

The system behaves in the following manner in the above scenarios:

Scenario	System Behaviour
On editing the attributes and characteristics of an account	<p>The system checks whether the account is eligible for repricing. If the account is eligible for repricing, the system checks whether a parameter for the account attribute or characteristic whichever is changed is already defined in the system. If the required parameters are available in the system, the system creates a repricing request for the account and effective date combination in the <b>CI_REPRC_REQ_DTL</b> table. On executing the <b>Process Repricing Request and Persist Pricing for an Account (C1-REPC2)</b> batch, you can recalculate and persist the rate for the account in the <b>CI_PRCE_CALC</b> table.</p> <p><b>Note:</b> On editing the account attributes, the effective date is set to the date when you edit the account attributes. However, on editing the account's characteristic, the effective date is set to the date from when the characteristic is effective for the account.</p>
On adding or deleting the usage amount and counter details of an account	<p>The system checks whether the account is eligible for repricing. If the account is eligible for repricing, the system checks whether a parameter for the usage amount or counter whichever is changed is already defined in the system. If the required parameters are available in the system, the system creates a repricing request for the account and effective date combination in the <b>CI_REPRC_REQ_DTL</b> table. On executing the <b>Process Repricing Request and Persist Pricing for an Account (C1-REPC2)</b> batch, you can recalculate and persist the rate for the account in the <b>CI_PRCE_CALC</b> table.</p> <p><b>Note:</b> The effective date is set to the date from when the usage amount or counter is effective for the account.</p>
On editing the attributes and characteristics of a person	<p>The system identifies all accounts which belong to the person and its child persons, and then checks whether the identified accounts are eligible for repricing. If one or more accounts are eligible for repricing, the system checks whether a parameter for the person attribute or characteristic whichever is changed is already defined in the system. If the required parameters are available in the system, the system creates a repricing request for the account and effective date combination in the <b>CI_REPRC_REQ_DTL</b> table. On executing the <b>Process Repricing Request and Persist Pricing for an Account (C1-REPC2)</b> batch, you can recalculate and persist the rate for the account in the <b>CI_PRCE_CALC</b> table.</p> <p><b>Note:</b></p> <p>Only accounts where the person and child person are the main customers are considered for repricing.</p> <p>On editing the person attributes, the effective date is set to the date when you edit the person attributes. However, on editing the person's characteristic, the effective date is set to the date from when the characteristic is effective for the person.</p>

Scenario	System Behaviour
<p>On adding or deleting the usage amount and counter details of a person</p>	<p>The system identifies all accounts which belong to the person and its child persons, and then checks whether the identified accounts are eligible for repricing. If one or more accounts are eligible for repricing, the system checks whether a parameter for the usage amount or counter whichever is changed is already defined in the system. If the required parameters are available in the system, the system creates a repricing request for the account and effective date combination in the <b>CI_REPRC_REQ_DTL</b> table. On executing the <b>Process Repricing Request and Persist Pricing for an Account (C1-REPC2)</b> batch, you can recalculate and persist the rate for the account in the <b>CI_PRCE_CALC</b> table.</p> <div data-bbox="605 514 1466 741" style="border: 1px solid black; padding: 5px;"> <p><b>Note:</b></p> <p>Only accounts where the person and child person are the main customers are considered for repricing.</p> <p>The effective date is set to the date from when the usage amount or counter is effective for the person.</p> </div>
<p>On assigning a price list to an account or editing the price list assignment details of an account</p>	<p>The system creates a repricing request for the account, price item, and effective date combination in the <b>CI_REPRC_REQ_DTL</b> table. If the price assignment end date and/or price list assignment end date is available, the system creates two repricing requests – one request where the effective date is set to the start date and another request where the effective date is set to the end date. The effective date is set to the price assignment start date or price list assignment start date depending on the following conditions:</p> <ul style="list-style-type: none"> <li>• If the Price Assignment Start Date is later than the Price List Assignment Start Date, then the effective date is set to Price Assignment Start Date.</li> <li>• If the Price Assignment Start Date is earlier than or equal to the Price List Assignment Start Date, then the effective date is set to Price List Assignment Start Date.</li> </ul> <p>However, the effective date is set to the price assignment end date or price list assignment end date depending on the following conditions:</p> <ul style="list-style-type: none"> <li>• If the Price Assignment End Date is earlier than the Price List Assignment End Date, then the effective date is set to Price Assignment End Date + 1 Day.</li> <li>• If the Price Assignment End Date is later than or equal to the Price List Assignment End Date, then the effective date is set to Price List Assignment End Date + 1 Day.</li> </ul> <p>On executing the <b>Process Repricing Request and Persist Pricing for an Account (C1-REPC2)</b> batch, you can recalculate and persist the rate for the account in the <b>CI_PRCE_CALC</b> table.</p> <div data-bbox="605 1612 1466 1692" style="border: 1px solid black; padding: 5px;"> <p><b>Note:</b> The system creates the repricing request for the account irrespective of whether the account is eligible for repricing or not.</p> </div>

Scenario	System Behaviour
<p>On assigning a price list to a person or editing the price list assignment details of a person</p>	<p>The system identifies all accounts which belong to the person and its child persons, and then creates a repricing request for the account, price item, and effective date combination in the <b>CI_REPRC_REQ_DTL</b> table. If the price assignment end date and/or price list assignment end date is available, the system creates two repricing requests – one request where the effective date is set to the start date and another request where the effective date is set to the end date. The effective date is set to the price assignment start date or price list assignment start date depending on the following conditions:</p> <ul style="list-style-type: none"> <li>• If the Price Assignment Start Date is later than the Price List Assignment Start Date, then the effective date is set to Price Assignment Start Date.</li> <li>• If the Price Assignment Start Date is earlier than or equal to the Price List Assignment Start Date, then the effective date is set to Price List Assignment Start Date.</li> </ul> <p>However, the effective date is set to the price assignment end date or price list assignment end date depending on the following conditions:</p> <ul style="list-style-type: none"> <li>• If the Price Assignment End Date is earlier than the Price List Assignment End Date, then the effective date is set to Price Assignment End Date + 1 Day.</li> <li>• If the Price Assignment End Date is later than or equal to the Price List Assignment End Date, then the effective date is set to Price List Assignment End Date + 1 Day.</li> </ul> <div style="border: 1px solid black; padding: 5px; margin-top: 10px;"> <p><b>Note:</b> If the Price List Assignment Start Date and Price List Assignment End Date are earlier than the current date, repricing requests for the accounts are not created in the <b>CI_REPRC_REQ_DTL</b> table.</p> </div> <p>On executing the <b>Process Repricing Request and Persist Pricing for an Account (C1-REPC2)</b> batch, you can recalculate and persist the rate for the account in the <b>CI_PRCE_CALC</b> table.</p> <div style="border: 1px solid black; padding: 5px; margin-top: 10px;"> <p><b>Note:</b></p> <p>Only accounts where the person and child person are the main customers are considered for repricing.</p> <p>The system creates the repricing request for the account irrespective of whether the account is eligible for repricing or not.</p> </div>
<p>On defining, editing, overriding, or copying the price item pricing of an account</p>	<p>The system creates a repricing request for the account, price item, and effective date combination in the <b>CI_REPRC_REQ_DTL</b> table. If the price assignment end date is specified, the system creates two repricing requests – one request where the effective date is set to the price assignment start date and another request where the effective date is set to the price assignment end date + 1 Day. On executing the <b>Process Repricing Request and Persist Pricing for an Account (C1-REPC2)</b> batch, you can recalculate and persist the rate for the account in the <b>CI_PRCE_CALC</b> table.</p> <div style="border: 1px solid black; padding: 5px; margin-top: 10px;"> <p><b>Note:</b> The system creates the repricing request for the account irrespective of whether the account is eligible for repricing or not.</p> </div>

Scenario	System Behaviour
On defining, editing, overriding, or copying the price item pricing of a person	<p>The system identifies all accounts which belong to the person and its child persons, and then creates a repricing request for the account, price item, and effective date combination in the <b>CI_REPRC_REQ_DTL</b> table. If the price assignment end date is specified, the system creates two repricing requests – one request where the effective date is set to the price assignment start date and another request where the effective date is set to the price assignment end date + 1 Day. On executing the <b>Process Repricing Request and Persist Pricing for an Account (C1-REPC2)</b> batch, you can recalculate and persist the rate for the account in the <b>CI_PRCE_CALC</b> table.</p> <div data-bbox="605 514 1464 741" style="border: 1px solid black; padding: 5px;"> <p><b>Note:</b></p> <p>Only accounts where the person and child person are the main customers are considered for repricing.</p> <p>The system creates the repricing request for the account irrespective of whether the account is eligible for repricing or not.</p> </div>
On defining or editing the price item pricing of an active price list which is assigned to an account or a person	<p>The system creates an entry for the price item pricing in the <b>CI_REPRC_ENTITY_DTL</b> table. On executing the <b>Identify Accounts for Repricing (C1-REPC1)</b> batch, the system identifies the following in the specified order:</p> <ol style="list-style-type: none"> <li>1. Price list on which the price item pricing is assigned</li> <li>2. Account or Person on which the price list is assigned</li> <li>3. All accounts which belong to the person and its child persons when the price list is assigned to a person</li> </ol> <p>Once the accounts are identified, the system checks whether the identified accounts are eligible for repricing. If one or more accounts are eligible for repricing, a repricing request is created for the account, price item, and effective date combination in the <b>CI_REPRC_REQ_DTL</b> table. If the price assignment end date is specified, the system creates two repricing requests – one request where the effective date is set to the price assignment start date and another request where the effective date is set to the price assignment end date + 1 Day. On executing the <b>Process Repricing Request and Persist Pricing for an Account (C1-REPC2)</b> batch, you can recalculate and persist the rate for the account in the <b>CI_PRCE_CALC</b> table.</p> <div data-bbox="605 1465 1464 1549" style="border: 1px solid black; padding: 5px;"> <p><b>Note:</b> Only accounts where the person and child person are the main customers are considered for repricing.</p> </div>

For more information about the **Identify Accounts for Repricing (C1-REPC1)** and **Process Repricing Request and Persist Pricing for an Account (C1-REPC2)** batches, refer to *Oracle Revenue Management and Billing Batch Guide*.

To enable the repricing feature, you need to do the following:

- Define an algorithm using the **C1-REPRCACCT** algorithm type and attach it to the **Audit** algorithm spot of the **C1-AccountBO** business object
- Define an algorithm using the **C1-REPRCACBC** algorithm type and attach it to the **Audit** algorithm spot of the **C1-ACCBALCNT** business object

- Define an algorithm using the **C1-REPRCPERS** algorithm type and attach it to the **Audit** algorithm spot of the **C1\_PERSON\_BO** business object
- Define an algorithm using the **C1-REPRCPPEBC** algorithm type and attach it to the **Audit** algorithm spot of the **C1-PERBALCNT** business object
- Define an algorithm using the **C1\_PLASGNAUD** algorithm type and attach it to the **Audit** algorithm spot of the **C1\_PLASGNADD** and **C1\_PLASGNEDIT** business objects
- Define an algorithm using the **C1-PRCASGNAD** algorithm type and attach it to the **Audit** algorithm spot of the **C1\_PRICEASGN\_BO** business object
- Define an algorithm using the **C1-REPRCPPLPA** algorithm type and attach it to the **Audit** algorithm spot of the **C1\_PRICEASGN\_BO** business object
- Define the required parameters for the account and person attributes, characteristics, usage amount and usage counter

## Two-Dimensional Pricing

---

Oracle Revenue Management and Billing enables you to define two-dimensional pricing for a price item. In the two-dimensional pricing, you can offer rates based on utilization of two service quantity identifiers (SQIs). For example, the rate for a price item can vary for each customer depending on the number of ATM transactions and current monthly balance as shown below: Current Monthly Balance Number of ATM Transactions 0-25 25-50 50-75 75-100 0-10000 2 1.9 1.8 1.7 10000-50000 1.6 1.5 1.4 1.3 50000-100000 1.2 1.1 1.0 0.9 100000-500000 0.8 0.7 0.6 0.5 The system allows you to define two-dimensional pricing in a grid which has X-axis and Y-axis. Both, the X-axis and Y-axis should contain service quantity identifiers (SQIs). The two-dimensional pricing is composed of threshold and step tiered pricing. The X-axis is a threshold tier and Y-axis is a step tier. On creating two-dimensional pricing, one price component is created for each X-axis and Y-axis combination. The step tier is stored as the tiering range whereas the threshold tier is stored as the eligibility criteria in the price component. Note that the tiering ranges and eligibility criteria are automatically created in the price component. You cannot manually add a tiering range and eligibility criteria in the price component. You can define two-dimensional pricing only when the tiering type of the rate components in the rate schedule is set to STEP. A new field named Pricing Rule Type is added in the Price Item Pricing screen. If you select the Two-Dimensional option from the Pricing Rule Type list, you can define two-dimensional pricing for the price item. However, if you do not select the Two-Dimensional option from the Pricing Rule Type list, you can define traditional flat, step, or tiered pricing for the price item. Besides selecting the Two-Dimensional option from the Pricing Rule Type list, you also need to select the Pricing Eligibility option while defining the two-dimensional pricing for the price item.

## Types of Price Item Bundle

---

The system allows you to define the following types of price item bundle:

- [Regular Bundle](#) on page 288
- [Phantom Bundle](#) on page 292
- [Ratio Bundle](#) on page 290

### Regular Bundle

In case of a regular bundle, pricing is defined at the bundle level. The system determines the rate by identifying the tiering range within which the total service quantities used for all price items in the bundle fall. Note that the rate is determined from the tiering range of the price component whose pricing eligibility criteria is met. Let us understand this with the help of an example.

Bundle X, which is a regular bundle, contains the following three price items:

- Price Item A



- Price Item B
- Price Item C

The following tiered pricing is defined for Bundle X:

Quantity Range	Rate (\$) per unit
1 – 3000	3
3001 – 4000	2
4001 – 8000	1

**Note:** In the above example, the assumption is that there only one rate component, one price component within the rate component, and pricing eligibility criteria is not defined for the price component.

Now, when the user consumes 1500 units of Price Item A, 1000 units of Price Item B, and 2000 units of Price Item C, the system adds the quantities of services used for all price items in Bundle X (i.e. 1500+1000+2000=4500), and then determines the range within which the total units (i.e. 4500) fall. In this case, the total units fall in the 4001 – 8000 range, and therefore the system uses \$1 as the rate for calculating charges.

If the multi parameter based pricing feature is enabled, you can define pricing for regular bundles based on multiple parameters. For example:

Bundle X	Country	Currency
Pricing 1	US	USD
Pricing 2	Germany	USD

Pricing 1 and Pricing 2 are defined for Bundle X based on two parameters — Country and Currency. Before you define pricing based on country and currency, you need to define these parameters in the system. Once you define these parameters, you need to associate them to the regular bundle (i.e. Bundle X) and then add price items (i.e. Price Item A, Price Item B, and Price Item C) to the bundle. Note that you can add a price item to a regular bundle only when the regular bundle and price item have same parameters associated with them for the specified date range. Therefore, before adding Price Item A, Price Item B, and Price Item C to Bundle X, you should ensure that Country and Currency are also associated with these price items.

Then, when you define Pricing 1 for Bundle X, you need to set the following price item parameters:

- Country — US
- Currency — USD

Similarly, you need to define Pricing 2 with Country set to Germany and Currency set to USD.

The following table lists the tiering ranges defined in Pricing 1 where price item parameters are set to US, USD:

Tier Sequence	Rate	Tiering Criteria	Price Item	Price Parameters	Item	From	To
10	2	Number of Transactions	Bundle X	US, USD		0	500
20	1	Number of Transactions	Bundle X	US, USD		500	

The following table lists the tiering ranges defined in Pricing 2 where price item parameters are set to Germany, USD:

Tier Sequence	Rate	Tiering Criteria	Price Item	Price Parameters	Item	From	To
10	4	Number of Transactions	Bundle X	Germany, USD		0	1000
20	3	Number of Transactions	Bundle X	Germany, USD		1000	

Now, when the user performs 500 transactions (in USD) of Bundle X in Germany, 1200 transactions (in USD) of Bundle X in US, the system creates two billable charges. In one billable charge (with Bundle X, US and USD combination), the system uses \$1 as the rate for calculating charges, and in another billable charge (with Bundle X, Germany and USD combination), the system uses \$4 as the rate for calculating charges.

## Ratio Bundle

In case of a ratio bundle, pricing is not defined at the bundle level. Instead, pricing is defined separately for each price item in the bundle.

A ratio expresses the magnitude of quantities relative to each other. It has two factors — Numerator and Denominator. For ratio bundle, the ratio of price item quantities is used to determine the rate for volume based pricing. To determine within which range of ratio limit does the price item utilization falls, the ratio of price item quantities is used. Once the range limits are determined, the rate specified for that range is applied to the quantity of the price item used. Let us understand this with the help of an example.

Bundle X, which is a ratio bundle, contains the following price items:

- **Price Item A** — It has been added to the bundle using the price item relationship type as Numerator. It has the following tiered pricing defined in the system:

Quantity Range	Rate (\$) per unit
0 – 0.6	4
0.6 – 0.9	3
0.9+	2

- **Price Item B** — It has been added to the bundle using the price item relationship type as Numerator. It has the following tiered pricing defined in the system:

Quantity Range	Rate (\$) per unit
0 – 0.6	5
0.6 – 0.9	4
0.9+	3

- **Price Item C** — It has been added to the bundle using the price item relationship type as Denominator. It has the following tiered pricing defined in the system:

Quantity Range	Rate (\$) per unit
0 – 0.6	3
0.6 – 0.9	2
0.9+	1

Now, when the user consumes 500 units of Price Item A, 2500 units of Price Item B, and 4000 units of Price Item C, the system calculates the ratio of price item quantities (i.e.  $(500+2500)/4000=0.75$ ). Once the ratio is calculated, the system determines the range of each price item within which the ratio (i.e. 0.75) falls. In this case, the ratio falls in the 0.6 – 0.9 range of Price Item A, B, and C. Therefore, the system uses \$3, \$4, and \$2, respectively, as the rate for calculating charges (i.e.  $(500*3)=1500$ ,  $(2500*4)=10000$ , and  $(4000*2)=8000$ ).

If the multi parameter based pricing feature is enabled, you can determine the price item utilization in a ratio bundle based on multiple parameters. For example:

Bundle X	Country	Currency
Price Item A	US	USD

<b>Bundle X</b>	<b>Country</b>	<b>Currency</b>
Price Item B	Germany	USD
Price Item C	England	USD

Price Item A, Price Item B, and Price Item C are added in Bundle X. Price Item A, Price Item B, and Price Item C utilization in Bundle X is determined based on two parameters — Country and Currency. Before you add price item to a ratio bundle, you need to define these parameters in the system. Once you define these parameters, you need to associate them to the price items (i.e. Price Item A, Price Item B, and Price Item C) and then add these price items to the bundle (i.e. Bundle X).

While adding Price Item A to Bundle X, you need to set the following price item parameters:

- Country — US
- Currency — USD

Similarly, you need to add Price Item B to Bundle X with Country set to Germany and Currency set to USD, and Price Item C with Country set to England and Currency set to USD.

The following table lists the tiered pricing defined for Price Item A:

<b>Tier Sequence</b>	<b>Rate</b>	<b>Tiering Criteria</b>	<b>Price Item</b>	<b>Price Parameters</b>	<b>Item</b>	<b>From</b>	<b>To</b>
10	5	Number of Transactions	Bundle X			0	1.75
20	4	Number of Transactions	Bundle X			1.75	2.50
30	3	Number of Transactions	Bundle X			2.50	

The following table lists the tiered pricing defined for Price Item B:

<b>Tier Sequence</b>	<b>Rate</b>	<b>Tiering Criteria</b>	<b>Price Item</b>	<b>Price Parameters</b>	<b>Item</b>	<b>From</b>	<b>To</b>
10	5	Number of Transactions	Bundle X			0	3.5
20	4	Number of Transactions	Bundle X			3.5	

The following table lists the tiered pricing defined for Price Item C:

<b>Tier Sequence</b>	<b>Rate</b>	<b>Tiering Criteria</b>	<b>Price Item</b>	<b>Price Parameters</b>	<b>Item</b>	<b>From</b>	<b>To</b>
10	2	Number of Transactions	Bundle X			0	2.0
20	1	Number of Transactions	Bundle X			2.0	

Now, when the user performs 5000 transactions (in USD) of Price Item A in US, 6000 transactions (in USD) of Price Item B in Germany, and 5000 transactions (in USD) of Price Item C in England, the system creates three billable charges — one for each price item (i.e. Price Item A, Price Item B, and Price Item C). The system calculates the ratio of transactions with the following combinations and then determines the range of each price item within which the ratio (i.e. 2.2) falls:

- Price Item A, US, USD
- Price Item B, Germany, USD
- Price Item C, England, USD

In this case, the ratio falls in the 1.75 – 2.50 range of Price Item A, the 0 – 3.5 range of Price Item B, and in the 2.0 — Infinite range of Price Item C. Therefore, the system uses \$4, \$5, and \$1 as the rate for calculating charges (i.e.  $(5000*4)=20000$  ,  $(6000*5)=30000$  , and  $(5000*1)=5000$ ).

You can also add a price item more than once in a ratio bundle with different set of parameters. For example:

Bundle X	Relationship Type	Country	Currency
Price Item A	Numerator	US	USD
Price Item A	Numerator	England	USD
Price Item B	Numerator	Germany	USD
Price Item C	Denominator	England	USD
Price Item C	Denominator	US	USD

In this case, the system calculates the ratio of transactions with the following combinations and then determines the range of each price item (i.e. Price Item A, Price Item B, and Price Item C) within which the ratio falls:

- Price Item A, US, USD
- Price Item A, England, USD
- Price Item B, Germany, USD
- Price Item C, England, USD
- Price Item C, US, USD

## Phantom Bundle

In case of a phantom bundle, pricing is not defined at the bundle level. Instead, pricing is defined separately for each price item in the bundle. The system determines the price by identifying the tiering range of each price item within which the total quantities of services used for all price items in the bundle fall. Let us understand this with the help of an example.

Bundle A, which is a phantom bundle, contains the following two price items:

- **Price Item X** — The following tiered pricing is defined for Price Item X:

Quantity Range	Rate (\$) per unit
1 – 3000	3
3001 – 6000	2

- **Price Item Y** — The following tiered pricing is defined for Price Item Y:

Quantity Range	Rate (\$) per unit
1 – 5000	2
5001 – 10000	1

Now, when the user consumes 2500 units of Price Item X and 3500 units of Price Item Y, the system adds the quantities of services used for all price items in Bundle A (i.e.  $2500+3500=6000$ ), and then determines the range of each price item within which the total units (i.e. 6000) fall. In this case, the total units fall in the 3001 – 6000 range of Price Item X and the 5001 – 10000 range of Price Item Y, and therefore the system uses \$2 and \$1, respectively, as the rate for calculating charges (i.e.  $(2500*2)=5000$  and  $(3500*1)=3500$ ). This helps the customer to take advantage of the lowest rate.

If the multi parameter based pricing feature is enabled, you can determine the price item utilization in a phantom bundle based on multiple parameters. For example:

Bundle A	Country	Currency
Price Item X	US	USD
Price Item Y	Germany	USD

Price Item X and Price Item Y are added in Bundle A. Price Item X and Price Item Y utilization in Bundle A is determined based on two parameters — Country and Currency. Before you add price item to a phantom bundle, you need to define these parameters in the system. Once you define these parameters, you need to associate them to the price items (i.e. Price Item X and Price Item Y) and then add these price items to the bundle (i.e. Bundle A).

While adding Price Item X to Bundle A, you need to set the following price item parameters:

- Country — US
- Currency — USD

Similarly, you need to add Product Y to Bundle A with Country set to Germany and Currency set to USD.

The following table lists the tiered pricing defined for Price Item X:

Tier Sequence	Rate	Tiering Criteria	Price Item	Price Parameters	Item	From	To
10	3	Number of Transactions	Bundle A			0	5000
20	2	Number of Transactions	Bundle A			5000	10000
30	1	Number of Transactions	Bundle A			10000	

The following table lists the tiered pricing defined for Price Item Y:

Tier Sequence	Rate	Tiering Criteria	Price Item	Price Parameters	Item	From	To
10	5	Number of Transactions	Bundle A			0	5000
20	4	Number of Transactions	Bundle A			5000	

Now, when the user performs 5000 transactions (in USD) of Price Item Y in Germany, 6000 transactions (in USD) of Price Item X in US, the system creates two billable charges — one for Price Item X and another for Price Item Y. The system adds the transactions with the following combinations and then determines the range of each price item within which the total units (i.e. 11000) fall:

- Price Item X, US, USD
- Price Item Y, Germany, USD

In this case, the total units fall in the 10000 – Infinite range of Price Item X and the 5000 – Infinite range of Price Item Y, and therefore the system uses \$1 and \$4, respectively, as the rate for calculating charges (i.e.  $(5000 * 4) = 20000$  and  $(6000 * 1) = 6000$ ).

You can also add a price item more than once in a phantom bundle with different set of parameters. For example:

Bundle A	Country	Currency
Price Item X	US	USD
Price Item X	Germany	USD
Price Item Y	Germany	USD
Price Item Y	US	USD

In this case, the system adds the transactions with the following combinations and then determines the range of each price item (i.e. Price Item X and Price Item Y) within which the total units fall:

- Price Item X, US, USD
- Price Item X, Germany, USD
- Price Item Y, Germany, USD

- Price Item Y, US, USD

## Parameter

The pricing for a price item may differ depending upon various transaction, person, account, or product attributes. Oracle Revenue Management and Billing provides a facility to define pricing for a price item based on multiple parameters. In addition, you can define the pricing, price list, and product eligibility criteria using one or more parameters.

Each parameter must be mapped to the following:

- **Source Entity** - Indicates the entity from where the parameter value is derived. A source entity can be account, person, product, transaction, service quantity identifier, or an algorithm.
- **Source Type** - Indicates the type of source from where the parameter value is derived. A source type can be field, characteristic, usage amount, or usage counter.
- **Source Type Code** - Indicates the source (such as, field, characteristic, usage amount, usage counter, SQI, or algorithm) from where the parameter value is derived.

The system allows you to define the following types of parameters:

- **Adhoc** - Used to store an adhoc value.
- **Predefined** - Used to store a predefined value. For example, you can create a parameter named **Country** where the value type is set to **Predefined** and the following predefined values are added in the parameter:

Parameter Value	Description
AUT	Austria
AUS	Australia
CAN	Canada
CHN	China

In such case, while defining the pricing for a price item using the **Country** parameter, you can use any one of the above mentioned parameter values.

- **Reference** - Used to store a value which is already present in a table. For example, you can create a parameter named **Country** where the value type is set to **Reference** and the reference entity is set to **CI\_COUNTRY\_L** (i.e. where the description of all countries is stored). In such case, while defining the pricing for a price item using the **Country** parameter, you can specify a country which is present in the **CI\_COUNTRY\_L** table in the parameter value.

## Parameter (Used for Searching)

The **Parameter** screen allows you to define, edit, delete and copy a parameter. It contains the following zone:

- [Search Parameter](#) on page 294

### Search Parameter

The **Search Parameter** zone allows you to search for a parameter using various search criteria. It contains the following two sections:





- **Search Criteria** - The **Search Criteria** section contains the following fields:

Field Name	Field Description	Mandatory (Yes or No)
Parameter	Used to search a particular parameter.	No

Field Name	Field Description	Mandatory (Yes or No)
Value Type	Used to search parameters in which you can store a particular type of value. The valid values are: <ul style="list-style-type: none"> <li>• Adhoc</li> <li>• Predefined</li> <li>• Reference</li> </ul>	No
Source Entity	Used to search parameters whose value is derived from a particular entity. The valid values are: <ul style="list-style-type: none"> <li>• Account</li> <li>• Algorithm</li> <li>• Person</li> <li>• Product</li> <li>• Service Quantity Identifier</li> <li>• Transaction</li> </ul>	No
Source Type	Used to search parameters whose value is derived from a particular type of source. The valid values are: <ul style="list-style-type: none"> <li>• Characteristic</li> <li>• Field</li> <li>• Usage Amount</li> <li>• Usage Counter</li> </ul>	No
Description	Used to search parameters with a particular description.	No

- **Search Results** - On clicking the **Search** button, the search results appear based on the specified search criteria. The **Search Results** section contains the following columns:

Column Name	Column Description
Parameter	Displays the parameter name.
Value Type	Indicates the type of value that you can store in the parameter. The valid values are: <ul style="list-style-type: none"> <li>• Adhoc</li> <li>• Predefined</li> <li>• Reference</li> </ul>
Description	Displays the description of the parameter.

Column Name	Column Description
Source Entity	Indicates the entity from where the parameter value is derived. The valid values are: <ul style="list-style-type: none"> <li>• Account</li> <li>• Algorithm</li> <li>• Person</li> <li>• Product</li> <li>• Service Quantity Identifier</li> <li>• Transaction</li> </ul>
Source Type	Indicates the type of source from where the parameter value is derived. The valid values are: <ul style="list-style-type: none"> <li>• Characteristic</li> <li>• Field</li> <li>• Usage Amount</li> <li>• Usage Counter</li> </ul>
View	On clicking the <b>View</b> (  ) icon, the <b>Parameter</b> screen appears where you can view the details of the parameter.
Edit	On clicking the <b>Edit</b> (  ) icon, the <b>Parameter</b> screen appears where you can edit the details of the parameter.
Delete	On clicking the <b>Delete</b> (  ) icon, you can delete the parameter. <div style="border: 1px solid black; padding: 5px; margin-top: 10px;"> <p><b>Note:</b></p> <p>You can delete a parameter only when the following conditions are met:</p> <ul style="list-style-type: none"> <li>• It is not yet associated to any price item or price item bundle.</li> <li>• It is not yet used while defining the pricing, price list, or product eligibility criteria.</li> </ul> </div>
Copy	On clicking the <b>Copy</b> (  ) icon, the <b>Parameter</b> screen appears where you can define a new parameter using an existing parameter.

**Note:** Pagination is used to display limited number of records in the **Search Results** section. You can use the navigation links, such as **Previous** and **Next** to navigate between pages.

### Related Topics

For more information on...	See...
How to search for a parameter	<a href="#">Searching for a Parameter</a> on page 297
How to edit a parameter	<a href="#">Editing a Parameter</a> on page 303
How to delete a parameter	<a href="#">Deleting a Parameter</a> on page 309
How to copy a parameter	<a href="#">Copying a Parameter</a> on page 310
How to view the details of a parameter	<a href="#">Viewing the Parameter Details</a> on page 315



## Searching for a Parameter

### Procedure

To search for a parameter:

1. Click the **Admin** link in the **Application** toolbar.  
A list appears.
2. From the **Admin** menu, select **P** and then click **Parameter**.  
The **Parameter** screen appears.
3. Enter the search criteria in the **Search Parameter** zone.

**Note:** ORMB search engine supports wildcard search, where you can substitute the percentage (%) symbol as a stand in for any word or letter in a search criteria. You can use the ‘%’ wildcard character in all input fields except the date and ID fields. The ‘%’ wildcard character is suffixed automatically at the end of the partial search criteria. Therefore, you may or may not specify the wildcard character at the end of the partial search criteria. However, you have to prefix the wildcard character manually wherever required.

4. Click **Search**.

A list of parameters that meet the search criteria appears in the **Search Results** section.

### Related Topics

For more information on...	See...
<b>Parameter</b> screen	<a href="#">Parameter (Used for Searching)</a> on page 294
<b>Search Parameter</b> zone	<a href="#">Search Parameter</a> on page 294

## Defining a Parameter

### Prerequisites

To define a parameter, you should have:

- Validation algorithm defined using the **C1\_PPARM\_VAL** algorithm type (in case you want to validate an adhoc parameter value)
- An algorithm defined using the **C1-PPARM-ENT** algorithm type (in case you want to use the algorithm while validating the pricing eligibility criteria)

### Note:

A sample algorithm type named **C1\_PPARM\_VAL** is shipped with the product. At present, it allows you to specify any special characters except ampersand (&), comma (,), underscore (\_), equal to (=), tilde (~), and semi-colon(;) in the parameter value.

A sample algorithm type named **C1-PPARM-ENT** is shipped with the product. At present, it returns a boolean value true. You can build custom logic in this algorithm which returns a value. This value can then be compared against the parameter value specified in the pricing eligibility criteria.

### Procedure

To define a parameter:

1. Click the **Admin** link in the **Application** toolbar.  
A list appears.

- From the **Admin** menu, select **P** and then click **Parameter**.



The **Parameter** screen appears.

- Click the **Add** button in the **Page Title** area of the **Parameter** screen.

The **Parameter** screen appears. It contains the following fields:

Field Name	Field Description	Mandatory (Yes or No)
Parameter	Used to specify the parameter name.  <b>Note:</b> You cannot specify any special character except underscore (_) in the parameter name.	Yes
Source Entity	Used to indicate the entity from where the parameter value should be derived. The valid values are: <ul style="list-style-type: none"> <li>Account</li> <li>Algorithm</li> <li>Person</li> <li>Product</li> <li>Service Quantity Identifier</li> <li>Transaction</li> </ul>	Yes
Description	Used to specify the description for the parameter.	Yes
Source Type	Used to indicate the type of source from where the parameter value should be derived. The valid values are: <ul style="list-style-type: none"> <li>Characteristic</li> <li>Field</li> <li>Usage Amount</li> <li>Usage Counter</li> </ul> <b>Note:</b> This field appears only when the <b>Account</b> , <b>Person</b> , or <b>Product</b> option is selected from the <b>Source Entity</b> list. The <b>Usage Amount</b> and <b>Usage Counter</b> options do not appear in the <b>Source Type</b> list when the <b>Product</b> option is selected from the <b>Source Entity</b> list.	Yes
Value Type	Used to indicate the type of value that you want to store in the parameter. The valid values are: <ul style="list-style-type: none"> <li>Adhoc</li> <li>Predefined</li> <li>Reference</li> </ul>	Yes

Field Name	Field Description	Mandatory (Yes or No)																																				
Source Type Code	<p>Used to indicate the source, such as field, characteristic, usage amount, usage counter, SQI, or algorithm, from where the parameter value should be derived.</p> <p><b>Note:</b></p> <p>This field does not appear when the <b>Transaction</b> option is selected from the <b>Source Entity</b> list.</p> <p>The following table indicates the values that are listed in the <b>Source Type Code</b> field depending on the source entity and source type combination:</p> <table border="1" data-bbox="483 604 1222 1717"> <thead> <tr> <th data-bbox="483 604 672 653">Source Entity</th> <th data-bbox="672 604 883 653">Source Type</th> <th data-bbox="883 604 1222 653">Source Type Code</th> </tr> </thead> <tbody> <tr> <td data-bbox="483 653 672 772">Account</td> <td data-bbox="672 653 883 772">Characteristic</td> <td data-bbox="883 653 1222 772">Lists all characteristics where the characteristic entity is set to <b>Account</b>.</td> </tr> <tr> <td data-bbox="483 772 672 856">Account</td> <td data-bbox="672 772 883 856">Field</td> <td data-bbox="883 772 1222 856">Lists all fields of the <b>CI_ACCT</b> table.</td> </tr> <tr> <td data-bbox="483 856 672 940">Account</td> <td data-bbox="672 856 883 940">Usage Amount</td> <td data-bbox="883 856 1222 940">Lists all values defined for the <b>BAL_FLG</b> lookup field.</td> </tr> <tr> <td data-bbox="483 940 672 1024">Account</td> <td data-bbox="672 940 883 1024">Usage Counter</td> <td data-bbox="883 940 1222 1024">Lists all values defined for the <b>CNT_FLG</b> lookup field.</td> </tr> <tr> <td data-bbox="483 1024 672 1144">Person</td> <td data-bbox="672 1024 883 1144">Characteristic</td> <td data-bbox="883 1024 1222 1144">Lists all characteristics where the characteristic entity is set to <b>Person</b>.</td> </tr> <tr> <td data-bbox="483 1144 672 1228">Person</td> <td data-bbox="672 1144 883 1228">Field</td> <td data-bbox="883 1144 1222 1228">Lists all fields of the <b>CI_PER</b> table.</td> </tr> <tr> <td data-bbox="483 1228 672 1312">Person</td> <td data-bbox="672 1228 883 1312">Usage Amount</td> <td data-bbox="883 1228 1222 1312">Lists all values defined for the <b>BAL_FLG</b> lookup field.</td> </tr> <tr> <td data-bbox="483 1312 672 1396">Person</td> <td data-bbox="672 1312 883 1396">Usage Counter</td> <td data-bbox="883 1312 1222 1396">Lists all values defined for the <b>CNT_FLG</b> lookup field.</td> </tr> <tr> <td data-bbox="483 1396 672 1495">Product</td> <td data-bbox="672 1396 883 1495">Characteristic</td> <td data-bbox="883 1396 1222 1495">Lists all characteristics where the characteristic entity is set to <b>Product</b>.</td> </tr> <tr> <td data-bbox="483 1495 672 1579">Product</td> <td data-bbox="672 1495 883 1579">Field</td> <td data-bbox="883 1495 1222 1579">Lists all fields of the <b>C1_PRODUCT</b> table.</td> </tr> <tr> <td data-bbox="483 1579 672 1717">Service Quantity Identifier</td> <td data-bbox="672 1579 883 1717">—</td> <td data-bbox="883 1579 1222 1717">Lists all service quantity identifiers available in the <b>CI_SQI</b> table.</td> </tr> </tbody> </table>	Source Entity	Source Type	Source Type Code	Account	Characteristic	Lists all characteristics where the characteristic entity is set to <b>Account</b> .	Account	Field	Lists all fields of the <b>CI_ACCT</b> table.	Account	Usage Amount	Lists all values defined for the <b>BAL_FLG</b> lookup field.	Account	Usage Counter	Lists all values defined for the <b>CNT_FLG</b> lookup field.	Person	Characteristic	Lists all characteristics where the characteristic entity is set to <b>Person</b> .	Person	Field	Lists all fields of the <b>CI_PER</b> table.	Person	Usage Amount	Lists all values defined for the <b>BAL_FLG</b> lookup field.	Person	Usage Counter	Lists all values defined for the <b>CNT_FLG</b> lookup field.	Product	Characteristic	Lists all characteristics where the characteristic entity is set to <b>Product</b> .	Product	Field	Lists all fields of the <b>C1_PRODUCT</b> table.	Service Quantity Identifier	—	Lists all service quantity identifiers available in the <b>CI_SQI</b> table.	Yes
Source Entity	Source Type	Source Type Code																																				
Account	Characteristic	Lists all characteristics where the characteristic entity is set to <b>Account</b> .																																				
Account	Field	Lists all fields of the <b>CI_ACCT</b> table.																																				
Account	Usage Amount	Lists all values defined for the <b>BAL_FLG</b> lookup field.																																				
Account	Usage Counter	Lists all values defined for the <b>CNT_FLG</b> lookup field.																																				
Person	Characteristic	Lists all characteristics where the characteristic entity is set to <b>Person</b> .																																				
Person	Field	Lists all fields of the <b>CI_PER</b> table.																																				
Person	Usage Amount	Lists all values defined for the <b>BAL_FLG</b> lookup field.																																				
Person	Usage Counter	Lists all values defined for the <b>CNT_FLG</b> lookup field.																																				
Product	Characteristic	Lists all characteristics where the characteristic entity is set to <b>Product</b> .																																				
Product	Field	Lists all fields of the <b>C1_PRODUCT</b> table.																																				
Service Quantity Identifier	—	Lists all service quantity identifiers available in the <b>CI_SQI</b> table.																																				

Field Name	Field Description	Mandatory (Yes or No)						
	<table border="1"> <thead> <tr> <th>Source Entity</th> <th>Source Type</th> <th>Source Type Code</th> </tr> </thead> <tbody> <tr> <td>Algorithm</td> <td>—</td> <td>Lists all algorithms which are defined using the <b>C1-PPARM-ENT</b> algorithm type.</td> </tr> </tbody> </table>	Source Entity	Source Type	Source Type Code	Algorithm	—	Lists all algorithms which are defined using the <b>C1-PPARM-ENT</b> algorithm type.	
Source Entity	Source Type	Source Type Code						
Algorithm	—	Lists all algorithms which are defined using the <b>C1-PPARM-ENT</b> algorithm type.						
Validation Algorithm	<p>Used to indicate the algorithm using which you want to validate the adhoc parameter value.</p> <p><b>Note:</b> This field appears only when the <b>Adhoc</b> option is selected from the <b>Value Type</b> list.</p> <p>The <b>Search</b>  icon appears corresponding to the <b>Validation Algorithm</b> field. On clicking the <b>Search</b> icon, the <b>Algorithm Search</b> window appears.</p>	No						
Reference Entity	<p>Used to indicate the table whose primary key (column) you want to set as the reference entity.</p> <p><b>Note:</b> This field appears only when the <b>Reference</b> option is selected from the <b>Value Type</b> list.</p> <p>The <b>Search</b>  icon appears corresponding to the <b>Reference Entity</b> field. On clicking the <b>Search</b> icon, the <b>Reference Table Search</b> window appears.</p> <p>You can only specify a language table, where the <b>DESCR</b> column is available, in the <b>Reference Entity</b> field.</p>	Yes						
Field Name	<p>Indicates the column which is the primary key of the table. The parameter value is then validated against the primary column of the table.</p> <p><b>Note:</b> This field appears only when the <b>Reference</b> option is selected from the <b>Value Type</b> list.</p>	Not applicable						

In addition, this screen contains the following two sections:



- **Parameter Values** - Used to define predefined values for the parameter. It contains the following fields in the grid:

Field Name	Field Description	Mandatory (Yes or No)
Parameter Value	Used to specify the parameter value.  <b>Note:</b> You can specify any special characters except ampersand (&), comma (,), underscore (_), equal to (=), tilde (~), and semi-colon(;) in the predefined parameter value.	Yes
Description	Used to specify the description for the parameter value.	Yes

**Note:**

The **Parameter Values** section appears only when the **Predefined** option is selected from the **Value Type** list.

At least one parameter value should be defined for a parameter where the value type is set to **Predefined**.

If you want to define more than one predefined value for the parameter, click the **Add** () icon and then specify the details. However, if you want to remove a predefined value of the parameter, click the **Delete** () icon corresponding to the parameter value.

- **Parameter Usage** - Used to indicate where the parameter can be used in the system. It contains the following options:

Option Name	Option Description	Mandatory (Yes or No)																
Price Item	<p>Used to indicate whether the parameter can be associated with a price item or price item bundle. If a parameter is associated with a price item or price item bundle, you can use the parameter while defining the price item pricing.</p> <p><b>Note:</b> The following table lists the source entity and source type combinations when the <b>Price Item</b> option is disabled in the <b>Parameter Usage</b> section:</p> <table border="1" data-bbox="542 562 1263 814"> <thead> <tr> <th>Source Entity</th> <th>Source Type</th> </tr> </thead> <tbody> <tr> <td>Account</td> <td>Usage Amount</td> </tr> <tr> <td>Account</td> <td>Usage Counter</td> </tr> <tr> <td>Person</td> <td>Usage Amount</td> </tr> <tr> <td>Person</td> <td>Usage Counter</td> </tr> </tbody> </table> <p>The following table lists the source entity and source type combinations when the <b>Price Item</b> option does not appear in the <b>Parameter Usage</b> section:</p> <table border="1" data-bbox="542 951 1263 1098"> <thead> <tr> <th>Source Entity</th> <th>Source Type</th> </tr> </thead> <tbody> <tr> <td>Algorithm</td> <td>—</td> </tr> <tr> <td>Service Quantity Identifier</td> <td>—</td> </tr> </tbody> </table>	Source Entity	Source Type	Account	Usage Amount	Account	Usage Counter	Person	Usage Amount	Person	Usage Counter	Source Entity	Source Type	Algorithm	—	Service Quantity Identifier	—	<p>Yes (Conditional)</p> <p><b>Note:</b> You must select this option when you want to associate the parameter with a price item.</p>
Source Entity	Source Type																	
Account	Usage Amount																	
Account	Usage Counter																	
Person	Usage Amount																	
Person	Usage Counter																	
Source Entity	Source Type																	
Algorithm	—																	
Service Quantity Identifier	—																	
Pricing Eligibility Criteria	<p>Used to indicate whether the parameter can be used while defining the pricing eligibility criteria.</p> <p><b>Note:</b> This option does not appear when the <b>Transaction</b> option is selected from the <b>Source Entity</b> list.</p>	<p>Yes (Conditional)</p> <p><b>Note:</b> You must select this option when you want to define a pricing eligibility criteria using the parameter.</p>																
Price List Eligibility Criteria	<p>Used to indicate whether the parameter can be used while defining the price list eligibility criteria.</p> <p><b>Note:</b> This option does not appear when the <b>Transaction</b> option is selected from the <b>Source Entity</b> list.</p>	<p>Yes (Conditional)</p> <p><b>Note:</b> You must select this option when you want to define a price list eligibility criteria using the parameter.</p>																

Option Name	Option Description	Mandatory (Yes or No)
Product Eligibility Criteria	Used to indicate whether the parameter can be used while defining the product eligibility criteria.  <b>Note:</b> This option does not appear when the <b>Algorithm</b> , <b>Service Quantity Identifier</b> , or <b>Transaction</b> option is selected from the <b>Source Entity</b> list.	Yes (Conditional)  <b>Note:</b> You must select this option when you want to define a product eligibility criteria using the parameter.

**Note:** You must select at least one option in the **Parameter Usage** section.

- Enter the required details in the **Parameter** screen depending on whether you want to create an adhoc, predefined, or reference parameter.
- Click **Save**.

The parameter is defined.

**Note:** If a parameter is already defined using the source entity, source type, and source type code combination, the system will not allow you to define another parameter with the same combination.

### Related Topics

For more information on...	See...
<b>Parameter</b> screen	<a href="#">Parameter (Used for Searching)</a> on page 294

### Editing a Parameter

#### Prerequisites

To edit a parameter, you should have:

- Validation algorithm defined using the **C1\_PPARM\_VAL** algorithm type (in case you want to validate an adhoc parameter value)
- An algorithm defined using the **C1-PPARM-ENT** algorithm type (in case you want to use the algorithm while validating the pricing eligibility criteria)

#### Note:

A sample algorithm type named **C1\_PPARM\_VAL** is shipped with the product. At present, it allows you to specify any special characters except ampersand (&), comma (,), underscore (\_), equal to (=), tilde (~), and semi-colon(;) in the parameter value.

A sample algorithm type named **C1-PPARM-ENT** is shipped with the product. At present, it returns a boolean value true. You can build custom logic in this algorithm which returns a value. This value can then be compared against the parameter value specified in the pricing eligibility criteria.

#### Procedure

To edit a parameter:

- Search for the parameter in the **Parameter** screen.



2. In the **Search Results** section, click the **Edit** (✎) icon in the **Edit** column corresponding to the parameter whose details you want to edit.

The **Parameter** screen appears. It contains the following fields:

Field Name	Field Description	Mandatory (Yes or No)
Parameter	Displays the parameter name.	Not applicable
Source Entity	Used to indicate the entity from where the parameter value should be derived. The valid values are: <ul style="list-style-type: none"> <li>Account</li> <li>Algorithm</li> <li>Person</li> <li>Product</li> <li>Service Quantity Identifier</li> <li>Transaction</li> </ul>	Yes
Description	Used to specify the description for the parameter.	Yes
Source Type	Used to indicate the type of source from where the parameter value should be derived. The valid values are: <ul style="list-style-type: none"> <li>Characteristic</li> <li>Field</li> <li>Usage Amount</li> <li>Usage Counter</li> </ul> <div style="border: 1px solid black; padding: 5px; margin-top: 10px;"> <p><b>Note:</b></p> <p>This field appears only when you select the <b>Account</b>, <b>Person</b>, or <b>Product</b> option from the <b>Source Entity</b> list.</p> <p>The <b>Usage Amount</b> and <b>Usage Counter</b> options do not appear in the <b>Source Type</b> list when the <b>Product</b> option is selected from the <b>Source Entity</b> list.</p> </div>	Yes
Value Type	Indicates the type of value that you can store in the parameter. The valid values are: <ul style="list-style-type: none"> <li>Adhoc</li> <li>Predefined</li> <li>Reference</li> </ul>	Not applicable
Source Type Code	Used to indicate the source, such as, field, characteristic, usage amount, usage counter, SQL, or algorithm, from where the parameter value should be derived.	Yes



Field Name	Field Description	Mandatory (Yes or No)																																				
	<p><b>Note:</b></p> <p>This field does not appear when the <b>Transaction</b> option is selected from the <b>Source Entity</b> list.</p> <p>The following table indicates the values that are listed in the <b>Source Type Code</b> field depending on the source entity and source type combination:</p> <table border="1" data-bbox="480 506 1203 1650"> <thead> <tr> <th data-bbox="480 506 664 583">Source Entity</th> <th data-bbox="669 506 841 583">Source Type</th> <th data-bbox="846 506 1203 583">Source Type Code</th> </tr> </thead> <tbody> <tr> <td data-bbox="480 590 664 699">Account</td> <td data-bbox="669 590 841 699">Characteristic</td> <td data-bbox="846 590 1203 699">Lists all characteristics where the characteristic entity is set to <b>Account</b>.</td> </tr> <tr> <td data-bbox="480 705 664 783">Account</td> <td data-bbox="669 705 841 783">Field</td> <td data-bbox="846 705 1203 783">Lists all fields of the <b>CI_ACCT</b> table.</td> </tr> <tr> <td data-bbox="480 789 664 867">Account</td> <td data-bbox="669 789 841 867">Usage Amount</td> <td data-bbox="846 789 1203 867">Lists all values defined for the <b>BAL_FLG</b> lookup field.</td> </tr> <tr> <td data-bbox="480 873 664 951">Account</td> <td data-bbox="669 873 841 951">Usage Counter</td> <td data-bbox="846 873 1203 951">Lists all values defined for the <b>CNT_FLG</b> lookup field.</td> </tr> <tr> <td data-bbox="480 957 664 1066">Person</td> <td data-bbox="669 957 841 1066">Characteristic</td> <td data-bbox="846 957 1203 1066">Lists all characteristics where the characteristic entity is set to <b>Person</b>.</td> </tr> <tr> <td data-bbox="480 1073 664 1150">Person</td> <td data-bbox="669 1073 841 1150">Field</td> <td data-bbox="846 1073 1203 1150">Lists all fields of the <b>CI_PER</b> table.</td> </tr> <tr> <td data-bbox="480 1157 664 1234">Person</td> <td data-bbox="669 1157 841 1234">Usage Amount</td> <td data-bbox="846 1157 1203 1234">Lists all values defined for the <b>BAL_FLG</b> lookup field.</td> </tr> <tr> <td data-bbox="480 1241 664 1318">Person</td> <td data-bbox="669 1241 841 1318">Usage Counter</td> <td data-bbox="846 1241 1203 1318">Lists all values defined for the <b>CNT_FLG</b> lookup field.</td> </tr> <tr> <td data-bbox="480 1325 664 1434">Product</td> <td data-bbox="669 1325 841 1434">Characteristic</td> <td data-bbox="846 1325 1203 1434">Lists all characteristics where the characteristic entity is set to <b>Product</b>.</td> </tr> <tr> <td data-bbox="480 1440 664 1507">Product</td> <td data-bbox="669 1440 841 1507">Field</td> <td data-bbox="846 1440 1203 1507">Lists all fields of the <b>CI_PRODUCT</b> table.</td> </tr> <tr> <td data-bbox="480 1514 664 1650">Service Quantity Identifier</td> <td data-bbox="669 1514 841 1650">—</td> <td data-bbox="846 1514 1203 1650">Lists all service quantity identifiers available in the <b>CI_SQI</b> table.</td> </tr> </tbody> </table>	Source Entity	Source Type	Source Type Code	Account	Characteristic	Lists all characteristics where the characteristic entity is set to <b>Account</b> .	Account	Field	Lists all fields of the <b>CI_ACCT</b> table.	Account	Usage Amount	Lists all values defined for the <b>BAL_FLG</b> lookup field.	Account	Usage Counter	Lists all values defined for the <b>CNT_FLG</b> lookup field.	Person	Characteristic	Lists all characteristics where the characteristic entity is set to <b>Person</b> .	Person	Field	Lists all fields of the <b>CI_PER</b> table.	Person	Usage Amount	Lists all values defined for the <b>BAL_FLG</b> lookup field.	Person	Usage Counter	Lists all values defined for the <b>CNT_FLG</b> lookup field.	Product	Characteristic	Lists all characteristics where the characteristic entity is set to <b>Product</b> .	Product	Field	Lists all fields of the <b>CI_PRODUCT</b> table.	Service Quantity Identifier	—	Lists all service quantity identifiers available in the <b>CI_SQI</b> table.	
Source Entity	Source Type	Source Type Code																																				
Account	Characteristic	Lists all characteristics where the characteristic entity is set to <b>Account</b> .																																				
Account	Field	Lists all fields of the <b>CI_ACCT</b> table.																																				
Account	Usage Amount	Lists all values defined for the <b>BAL_FLG</b> lookup field.																																				
Account	Usage Counter	Lists all values defined for the <b>CNT_FLG</b> lookup field.																																				
Person	Characteristic	Lists all characteristics where the characteristic entity is set to <b>Person</b> .																																				
Person	Field	Lists all fields of the <b>CI_PER</b> table.																																				
Person	Usage Amount	Lists all values defined for the <b>BAL_FLG</b> lookup field.																																				
Person	Usage Counter	Lists all values defined for the <b>CNT_FLG</b> lookup field.																																				
Product	Characteristic	Lists all characteristics where the characteristic entity is set to <b>Product</b> .																																				
Product	Field	Lists all fields of the <b>CI_PRODUCT</b> table.																																				
Service Quantity Identifier	—	Lists all service quantity identifiers available in the <b>CI_SQI</b> table.																																				

Field Name	Field Description	Mandatory (Yes or No)						
	<table border="1"> <thead> <tr> <th>Source Entity</th> <th>Source Type</th> <th>Source Type Code</th> </tr> </thead> <tbody> <tr> <td>Algorithm</td> <td>—</td> <td>Lists all algorithms which are defined using the <b>C1-PPARM-ENT</b> algorithm type.</td> </tr> </tbody> </table>	Source Entity	Source Type	Source Type Code	Algorithm	—	Lists all algorithms which are defined using the <b>C1-PPARM-ENT</b> algorithm type.	
Source Entity	Source Type	Source Type Code						
Algorithm	—	Lists all algorithms which are defined using the <b>C1-PPARM-ENT</b> algorithm type.						
Validation Algorithm	<p>Used to indicate the algorithm using which you want to validate the adhoc parameter value.</p> <p><b>Note:</b> This field appears only when the <b>Adhoc</b> option is selected from the <b>Value Type</b> list.</p> <p>The <b>Search</b>  icon appears corresponding to the <b>Validation Algorithm</b> field. On clicking the <b>Search</b> icon, the <b>Algorithm Search</b> window appears.</p>	No						
Reference Entity	<p>Used to indicate the table whose primary key (column) you want to set as the reference entity.</p> <p><b>Note:</b> This field appears only when the <b>Reference</b> option is selected from the <b>Value Type</b> list.</p> <p>The <b>Search</b>  icon appears corresponding to the <b>Reference Entity</b> field. On clicking the <b>Search</b> icon, the <b>Reference Table Search</b> window appears.</p> <p>You can only specify a language table, where the <b>DESCR</b> column is available, in the <b>Reference Entity</b> field.</p>	Yes						
Field Name	<p>Indicates the column which is the primary key of the table. The parameter value is then validated against the primary column of the table.</p> <p><b>Note:</b> This field appears only when the <b>Reference</b> option is selected from the <b>Value Type</b> list.</p>	Not applicable						

In addition, this screen contains the following two sections:



- **Parameter Values** - Used to define predefined values for the parameter. It contains the following fields in the grid:

Field Name	Field Description	Mandatory (Yes or No)
Parameter Value	Used to specify the parameter value.  <b>Note:</b> You can specify any special characters except ampersand (&), comma (,), underscore (_), equal to (=), tilde (~), and semi-colon(;) in the predefined parameter value.	Yes
Description	Used to specify the description for the parameter value.	Yes

**Note:**

The **Parameter Values** section appears only when the **Predefined** option is selected from the **Value Type** list.

At least one parameter value should be defined for a parameter where the value type is set to **Predefined**.

If you want to define more than one predefined value for the parameter, click the **Add** () icon and then specify the details. However, if you want to remove a predefined value of the parameter, click the **Delete** () icon corresponding to the parameter value.

You cannot delete a predefined parameter value which is already used in the system.

- **Parameter Usage** - Used to indicate where the parameter can be used in the system. It contains the following options:

Option Name	Option Description	Mandatory (Yes or No)																
Price Item	<p>Used to indicate whether the parameter can be associated with a price item or price item bundle. If a parameter is associated with a price item or price item bundle, you can use the parameter while defining the price item pricing.</p> <p><b>Note:</b> The following table lists the source entity and source type combinations when the <b>Price Item</b> option is disabled in the <b>Parameter Usage</b> section:</p> <table border="1" data-bbox="581 590 1107 842"> <thead> <tr> <th>Source Entity</th> <th>Source Type</th> </tr> </thead> <tbody> <tr> <td>Account</td> <td>Usage Amount</td> </tr> <tr> <td>Account</td> <td>Usage Counter</td> </tr> <tr> <td>Person</td> <td>Usage Amount</td> </tr> <tr> <td>Person</td> <td>Usage Counter</td> </tr> </tbody> </table> <p>The following table lists the source entity and source type combinations when the <b>Price Item</b> option does not appear in the <b>Parameter Usage</b> section:</p> <table border="1" data-bbox="581 1010 1107 1192"> <thead> <tr> <th>Source Entity</th> <th>Source Type</th> </tr> </thead> <tbody> <tr> <td>Algorithm</td> <td>—</td> </tr> <tr> <td>Service Identifier</td> <td>Quantity</td> </tr> </tbody> </table>	Source Entity	Source Type	Account	Usage Amount	Account	Usage Counter	Person	Usage Amount	Person	Usage Counter	Source Entity	Source Type	Algorithm	—	Service Identifier	Quantity	<p>Yes (Conditional)</p> <p><b>Note:</b> This field is required when you want to associate the parameter with a price item.</p>
Source Entity	Source Type																	
Account	Usage Amount																	
Account	Usage Counter																	
Person	Usage Amount																	
Person	Usage Counter																	
Source Entity	Source Type																	
Algorithm	—																	
Service Identifier	Quantity																	
Pricing Eligibility Criteria	<p>Used to indicate whether the parameter can be used while defining the pricing eligibility criteria.</p> <p><b>Note:</b> This option does not appear when the <b>Transaction</b> option is selected from the <b>Source Entity</b> list.</p>	<p>Yes (Conditional)</p> <p><b>Note:</b> This field is required when you want to define a pricing eligibility criteria using the parameter.</p>																
Price List Eligibility Criteria	<p>Used to indicate whether the parameter can be used while defining the price list eligibility criteria.</p> <p><b>Note:</b> This option does not appear when the <b>Transaction</b> option is selected from the <b>Source Entity</b> list.</p>	<p>Yes (Conditional)</p> <p><b>Note:</b> This field is required when you want to define a price list eligibility criteria using the parameter.</p>																

Option Name	Option Description	Mandatory (Yes or No)
Product Eligibility Criteria	Used to indicate whether the parameter can be used while defining the product eligibility criteria.  <b>Note:</b> This option does not appear when the <b>Algorithm</b> , <b>Service Quantity Identifier</b> , or <b>Transaction</b> option is selected from the <b>Source Entity</b> list.	Yes (Conditional)  <b>Note:</b> This field is required when you want to define a product eligibility criteria using the parameter.

**Note:**  
You must select at least one option in the **Parameter Usage** section.  
  
If the parameter is already associated to a price item or used while defining the pricing, price list, or product eligibility criteria, you cannot deselect the respective option in the **Parameter Usage** section.

3. Modify the required details in the **Parameter** screen.
4. Click **Save**.

The changes made to the parameter are saved.

#### **Related Topics**

For more information on...	See...
How to search for a parameter	<a href="#">Searching for a Parameter</a> on page 297

#### **Deleting a Parameter**

##### **Procedure**

To delete a parameter:

1. Search for the parameter in the **Parameter** screen.
2. In the **Search Results** section, click the **Delete** (🗑️) icon in the **Delete** column corresponding to the parameter that you want to delete.

A message appears confirming whether you want to delete the parameter.

**Note:**  
You can delete a parameter only when the following conditions are met:

- It is not yet associated to any price item or price item bundle.
- It is not yet used while defining the pricing, price list, or product eligibility criteria.

3. Click **OK**.

The parameter is deleted.

#### **Related Topics**

For more information on...	See...
How to search for a parameter	<a href="#">Searching for a Parameter</a> on page 297

## Copying a Parameter

Instead of creating a parameter from scratch, you can define a new parameter using an existing parameter. This is possible through copying a parameter. When you copy a parameter, the predefined values, validation algorithm, and reference entity (depending upon the value type) are copied along with other parameter details. You can then edit the details, if required.

**Note:** You cannot change the type of value that you can store in the new parameter (which is created using an existing parameter).

### Prerequisites

To copy a parameter, you should have:

- Parameter (whose copy you want to create) defined in the application
- Validation algorithm defined using the **C1\_PPARM\_VAL** algorithm type (in case you want to validate an adhoc parameter value)
- An algorithm defined using the **C1-PPARM-ENT** algorithm type (in case you want to use the algorithm while validating the pricing eligibility criteria)

### Note:

A sample algorithm type named **C1\_PPARM\_VAL** is shipped with the product. At present, it allows you to specify any special characters except ampersand (&), comma (,), underscore (\_), equal to (=), tilde (~), and semi-colon(;) in the parameter value.

A sample algorithm type named **C1-PPARM-ENT** is shipped with the product. At present, it returns a boolean value true. You can build custom logic in this algorithm which returns a value. This value can then be compared against the parameter value specified in the pricing eligibility criteria.

### Procedure

To copy a parameter:

1. Search for the parameter in the **Parameter** screen.
2. In the **Search Results** section, click the **Copy** () icon in the **Copy** column corresponding to the parameter whose copy you want to create.

The **Parameter** screen appears. It contains the following fields:

Field Name	Field Description	Mandatory (Yes or No)
Parameter	Used to specify the parameter name.  <b>Note:</b> You cannot specify any special character except underscore (_) in the parameter name.	Yes

Field Name	Field Description	Mandatory (Yes or No)
Source Entity	Used to indicate the entity from where the parameter value should be derived. The valid values are: <ul style="list-style-type: none"> <li>• Account</li> <li>• Algorithm</li> <li>• Person</li> <li>• Product</li> <li>• Service Quantity Identifier</li> <li>• Transaction</li> </ul>	Yes
Description	Used to specify the description for the parameter.	Yes
Source Type	Used to indicate the type of source from where the parameter value should be derived. The valid values are: <ul style="list-style-type: none"> <li>• Characteristic</li> <li>• Field</li> <li>• Usage Amount</li> <li>• Usage Counter</li> </ul> <div style="border: 1px solid black; padding: 5px; margin-top: 10px;"> <p><b>Note:</b></p> <p>This field appears only when you select the <b>Account</b>, <b>Person</b>, or <b>Product</b> option from the <b>Source Entity</b> list.</p> <p>The <b>Usage Amount</b> and <b>Usage Counter</b> options do not appear in the <b>Source Type</b> list when the <b>Product</b> option is selected from the <b>Source Entity</b> list.</p> </div>	Yes
Value Type	Indicates the type of value that you can store in the parameter. The valid values are: <ul style="list-style-type: none"> <li>• Adhoc</li> <li>• Predefined</li> <li>• Reference</li> </ul>	Not applicable

Field Name	Field Description	Mandatory (Yes or No)																																				
Source Type Code	<p>Used to indicate the source, such as, field, characteristic, usage amount, usage counter, SQI, or algorithm, from where the parameter value should be derived.</p> <p><b>Note:</b></p> <p>This field does not appear when the <b>Transaction</b> option is selected from the <b>Source Entity</b> list.</p> <p>The following table indicates the values that are listed in the <b>Source Type Code</b> field depending on the source entity and source type combination:</p> <table border="1" data-bbox="451 575 1240 1682"> <thead> <tr> <th data-bbox="451 575 651 625">Source Entity</th> <th data-bbox="651 575 878 625">Source Type</th> <th data-bbox="878 575 1240 625">Source Type Code</th> </tr> </thead> <tbody> <tr> <td data-bbox="451 625 651 741">Account</td> <td data-bbox="651 625 878 741">Characteristic</td> <td data-bbox="878 625 1240 741">Lists all characteristics where the characteristic entity is set to <b>Account</b>.</td> </tr> <tr> <td data-bbox="451 741 651 821">Account</td> <td data-bbox="651 741 878 821">Field</td> <td data-bbox="878 741 1240 821">Lists all fields of the <b>CI_ACCT</b> table.</td> </tr> <tr> <td data-bbox="451 821 651 903">Account</td> <td data-bbox="651 821 878 903">Usage Amount</td> <td data-bbox="878 821 1240 903">Lists all values defined for the <b>BAL_FLG</b> lookup field.</td> </tr> <tr> <td data-bbox="451 903 651 982">Account</td> <td data-bbox="651 903 878 982">Usage Counter</td> <td data-bbox="878 903 1240 982">Lists all values defined for the <b>CNT_FLG</b> lookup field.</td> </tr> <tr> <td data-bbox="451 982 651 1098">Person</td> <td data-bbox="651 982 878 1098">Characteristic</td> <td data-bbox="878 982 1240 1098">Lists all characteristics where the characteristic entity is set to <b>Person</b>.</td> </tr> <tr> <td data-bbox="451 1098 651 1180">Person</td> <td data-bbox="651 1098 878 1180">Field</td> <td data-bbox="878 1098 1240 1180">Lists all fields of the <b>CI_PER</b> table.</td> </tr> <tr> <td data-bbox="451 1180 651 1262">Person</td> <td data-bbox="651 1180 878 1262">Usage Amount</td> <td data-bbox="878 1180 1240 1262">Lists all values defined for the <b>BAL_FLG</b> lookup field.</td> </tr> <tr> <td data-bbox="451 1262 651 1344">Person</td> <td data-bbox="651 1262 878 1344">Usage Counter</td> <td data-bbox="878 1262 1240 1344">Lists all values defined for the <b>CNT_FLG</b> lookup field.</td> </tr> <tr> <td data-bbox="451 1344 651 1459">Product</td> <td data-bbox="651 1344 878 1459">Characteristic</td> <td data-bbox="878 1344 1240 1459">Lists all characteristics where the characteristic entity is set to <b>Product</b>.</td> </tr> <tr> <td data-bbox="451 1459 651 1541">Product</td> <td data-bbox="651 1459 878 1541">Field</td> <td data-bbox="878 1459 1240 1541">Lists all fields of the <b>C1_PRODUCT</b> table.</td> </tr> <tr> <td data-bbox="451 1541 651 1656">Service Quantity Identifier</td> <td data-bbox="651 1541 878 1656">—</td> <td data-bbox="878 1541 1240 1656">Lists all service quantity identifiers available in the <b>CI_SQI</b> table.</td> </tr> </tbody> </table>	Source Entity	Source Type	Source Type Code	Account	Characteristic	Lists all characteristics where the characteristic entity is set to <b>Account</b> .	Account	Field	Lists all fields of the <b>CI_ACCT</b> table.	Account	Usage Amount	Lists all values defined for the <b>BAL_FLG</b> lookup field.	Account	Usage Counter	Lists all values defined for the <b>CNT_FLG</b> lookup field.	Person	Characteristic	Lists all characteristics where the characteristic entity is set to <b>Person</b> .	Person	Field	Lists all fields of the <b>CI_PER</b> table.	Person	Usage Amount	Lists all values defined for the <b>BAL_FLG</b> lookup field.	Person	Usage Counter	Lists all values defined for the <b>CNT_FLG</b> lookup field.	Product	Characteristic	Lists all characteristics where the characteristic entity is set to <b>Product</b> .	Product	Field	Lists all fields of the <b>C1_PRODUCT</b> table.	Service Quantity Identifier	—	Lists all service quantity identifiers available in the <b>CI_SQI</b> table.	Yes
Source Entity	Source Type	Source Type Code																																				
Account	Characteristic	Lists all characteristics where the characteristic entity is set to <b>Account</b> .																																				
Account	Field	Lists all fields of the <b>CI_ACCT</b> table.																																				
Account	Usage Amount	Lists all values defined for the <b>BAL_FLG</b> lookup field.																																				
Account	Usage Counter	Lists all values defined for the <b>CNT_FLG</b> lookup field.																																				
Person	Characteristic	Lists all characteristics where the characteristic entity is set to <b>Person</b> .																																				
Person	Field	Lists all fields of the <b>CI_PER</b> table.																																				
Person	Usage Amount	Lists all values defined for the <b>BAL_FLG</b> lookup field.																																				
Person	Usage Counter	Lists all values defined for the <b>CNT_FLG</b> lookup field.																																				
Product	Characteristic	Lists all characteristics where the characteristic entity is set to <b>Product</b> .																																				
Product	Field	Lists all fields of the <b>C1_PRODUCT</b> table.																																				
Service Quantity Identifier	—	Lists all service quantity identifiers available in the <b>CI_SQI</b> table.																																				



Field Name	Field Description	Mandatory (Yes or No)						
	<table border="1"> <thead> <tr> <th>Source Entity</th> <th>Source Type</th> <th>Source Type Code</th> </tr> </thead> <tbody> <tr> <td>Algorithm</td> <td>—</td> <td>Lists all algorithms which are defined using the <b>C1-PPARM-ENT</b> algorithm type.</td> </tr> </tbody> </table>	Source Entity	Source Type	Source Type Code	Algorithm	—	Lists all algorithms which are defined using the <b>C1-PPARM-ENT</b> algorithm type.	
Source Entity	Source Type	Source Type Code						
Algorithm	—	Lists all algorithms which are defined using the <b>C1-PPARM-ENT</b> algorithm type.						
Validation Algorithm	<p>Used to indicate the algorithm using which you want to validate the adhoc parameter value.</p> <p><b>Note:</b> This field appears only when the <b>Adhoc</b> option is selected from the <b>Value Type</b> list. The <b>Search</b> (🔍) icon appears corresponding to the <b>Validation Algorithm</b> field. On clicking the <b>Search</b> icon, the <b>Algorithm Search</b> window appears.</p>	No						
Reference Entity	<p>Used to indicate the table whose primary key (column) you want to set as the reference entity.</p> <p><b>Note:</b> This field appears only when the <b>Reference</b> option is selected from the <b>Value Type</b> list. The <b>Search</b> (🔍) icon appears corresponding to the <b>Reference Entity</b> field. On clicking the <b>Search</b> icon, the <b>Reference Table Search</b> window appears. You can only specify a language table, where the <b>DESCR</b> column is available, in the <b>Reference Entity</b> field.</p>	Yes						
Field Name	<p>Indicates the column which is the primary key of the table. The parameter value is then validated against the primary column of the table.</p> <p><b>Note:</b> This field appears only when the <b>Reference</b> option is selected from the <b>Value Type</b> list.</p>	Not applicable						

In addition, this screen contains the following two sections:

- **Parameter Values** - Used to define predefined values for the parameter. It contains the following fields in the grid:

Field Name	Field Description	Mandatory (Yes or No)
Parameter Value	<p>Used to specify the parameter value.</p> <p><b>Note:</b> You can specify any special characters except ampersand (&amp;), comma (,), underscore (_), equal to (=), tilde (~), and semi-colon(;) in the predefined parameter value.</p>	Yes

Field Name	Field Description	Mandatory (Yes or No)
Description	Used to specify the description for the parameter value.	Yes

**Note:**

The **Parameter Values** section appears only when the **Predefined** option is selected from the **Value Type** list.

At least one parameter value should be defined for a parameter where the value type is set to **Predefined**.

If you want to define more than one predefined value for the parameter, click the **Add** (+) icon and then specify the details. However, if you want to remove a predefined value of the parameter, click the **Delete** (🗑) icon corresponding to the parameter value.

- **Parameter Usage** - Used to indicate where the parameter can be used in the system. It contains the following options:

Option Name	Option Description	Mandatory (Yes or No)																
Price Item	<p>Used to indicate whether the parameter can be associated with a price item or price item bundle. If a parameter is associated with a price item or price item bundle, you can use the parameter while defining the price item pricing.</p> <p><b>Note:</b></p> <p>The following table lists the source entity and source type combinations when the <b>Price Item</b> option is disabled in the <b>Parameter Usage</b> section:</p> <table border="1"> <thead> <tr> <th>Source Entity</th> <th>Source Type</th> </tr> </thead> <tbody> <tr> <td>Account</td> <td>Usage Amount</td> </tr> <tr> <td>Account</td> <td>Usage Counter</td> </tr> <tr> <td>Person</td> <td>Usage Amount</td> </tr> <tr> <td>Person</td> <td>Usage Counter</td> </tr> </tbody> </table> <p>The following table lists the source entity and source type combinations when the <b>Price Item</b> option does not appear in the <b>Parameter Usage</b> section:</p> <table border="1"> <thead> <tr> <th>Source Entity</th> <th>Source Type</th> </tr> </thead> <tbody> <tr> <td>Algorithm</td> <td>—</td> </tr> <tr> <td>Service Quantity Identifier</td> <td>—</td> </tr> </tbody> </table>	Source Entity	Source Type	Account	Usage Amount	Account	Usage Counter	Person	Usage Amount	Person	Usage Counter	Source Entity	Source Type	Algorithm	—	Service Quantity Identifier	—	<p>Yes (Conditional)</p> <p><b>Note:</b> This field is required when you want to associate the parameter with a price item.</p>
Source Entity	Source Type																	
Account	Usage Amount																	
Account	Usage Counter																	
Person	Usage Amount																	
Person	Usage Counter																	
Source Entity	Source Type																	
Algorithm	—																	
Service Quantity Identifier	—																	

Option Name	Option Description	Mandatory (Yes or No)
Pricing Eligibility Criteria	Used to indicate whether the parameter can be used while defining the pricing eligibility criteria.  <b>Note:</b> This option does not appear when the <b>Transaction</b> option is selected from the <b>Source Entity</b> list.	Yes (Conditional)  <b>Note:</b> This field is required when you want to define a pricing eligibility criteria using the parameter.
Price List Eligibility Criteria	Used to indicate whether the parameter can be used while defining the price list eligibility criteria.  <b>Note:</b> This option does not appear when the <b>Transaction</b> option is selected from the <b>Source Entity</b> list.	Yes (Conditional)  <b>Note:</b> This field is required when you want to define a price list eligibility criteria using the parameter.
Product Eligibility Criteria	Used to indicate whether the parameter can be used while defining the product eligibility criteria.  <b>Note:</b> This option does not appear when the <b>Algorithm</b> , <b>Service Quantity Identifier</b> , or <b>Transaction</b> option is selected from the <b>Source Entity</b> list.	Yes (Conditional)  <b>Note:</b> This field is required when you want to define a product eligibility criteria using the parameter.

**Note:** You must select at least one option in the **Parameter Usage** section.

- Enter the required details in the **Parameter** screen depending on whether you want to create an adhoc, predefined, or reference parameter.
- Click **Save**.

The parameter is defined.

**Note:** If a parameter is already defined using the source entity, source type, and source type code combination, the system will not allow you to define another parameter with the same combination.

### Related Topics

For more information on...	See...
How to search for a parameter	<a href="#">Searching for a Parameter</a> on page 297

### Viewing the Parameter Details

#### Procedure

To view the details of a parameter:

- Search for the parameter in the **Parameter** screen.
- In the **Search Results** section, click the **View** (🔍) icon in the **View** column corresponding to the parameter whose details you want to view.

The **Parameter** screen appears.

- View the details of the parameter in the **Parameter** screen.

### Related Topics

For more information on...	See...
How to search for a parameter	<a href="#">Searching for a Parameter</a> on page 297
<b>Parameter</b> screen	<a href="#">Parameter (Used for Viewing)</a> on page 316
<b>Parameter</b> zone	<a href="#">Parameters</a> on page 342

## Parameter (Used for Viewing)

The **Parameter** screen allows you to view the details of a parameter. It contains the following zone:

- [Parameter](#) on page 316

### **Parameter**

The **Parameter** zone displays the details of the parameter. It contains the following sections:

- Main** – Displays basic information about the parameter. It contains the following fields:

Field Name	Field Description
Parameter	Displays the parameter name.
Description	Displays the description of the parameter.
Value Type	Indicates the type of value that you can store in the parameter. The valid values are: <ul style="list-style-type: none"> <li>Adhoc</li> <li>Predefined</li> <li>Reference</li> </ul>
Validation Algorithm	Indicates the algorithm which is used to validate the adhoc parameter value. <div style="border: 1px solid black; padding: 5px; margin-top: 10px;"> <p><b>Note:</b></p> <p>This field appears only when the <b>Adhoc</b> option is selected from the <b>Value Type</b> list.</p> <p>It has a link. On clicking the link, the <b>Algorithm</b> screen appears where you can view the details of the respective algorithm.</p> </div>
Referenced Table	Indicates the table whose primary key (i.e. column) is used to validate the parameter value. <div style="border: 1px solid black; padding: 5px; margin-top: 10px;"> <p><b>Note:</b></p> <p>This field appears only when the <b>Reference</b> option is selected from the <b>Value Type</b> list.</p> <p>It has a link. On clicking the link, the <b>Table</b> screen appears where you can view the details of the respective table.</p> </div>

Field Name	Field Description
Source Entity	<p>Indicates the entity from where the parameter value is derived. The valid values are:</p> <ul style="list-style-type: none"> <li>• Account</li> <li>• Algorithm</li> <li>• Person</li> <li>• Product</li> <li>• Service Quantity Identifier</li> <li>• Transaction</li> </ul>
Source Type	<p>Indicates the type of source from where the parameter value is derived. The valid values are:</p> <ul style="list-style-type: none"> <li>• Characteristic</li> <li>• Field</li> <li>• Usage Amount</li> <li>• Usage Counter</li> </ul> <p><b>Note:</b> This field appears only when the <b>Account</b>, <b>Person</b>, or <b>Product</b> option is selected from the <b>Source Entity</b> list.</p>
Source Type Code	<p>Indicates the source, such as field, characteristic, usage amount, usage counter, SQI, or algorithm, from where the parameter value is derived.</p> <p><b>Note:</b> This field does not appear when the <b>Transaction</b> option is selected from the <b>Source Entity</b> list.</p>

- **Parameter Usage** – Indicates where the parameter can be used in the system. It contains the following options:

Option Name	Option Description						
Price Item	<p>Indicates whether the parameter can be associated with a price item or price item bundle. If a parameter is associated with a price item or price item bundle, you can use the parameter while defining the price item pricing.</p> <p>The following table lists the source entity and source type combinations when the <b>Price Item</b> option does not appear in the <b>Parameter Usage</b> section:</p> <table border="1"> <thead> <tr> <th>Source Entity</th> <th>Source Type</th> </tr> </thead> <tbody> <tr> <td>Algorithm</td> <td>—</td> </tr> <tr> <td>Service Quantity Identifier</td> <td>—</td> </tr> </tbody> </table>	Source Entity	Source Type	Algorithm	—	Service Quantity Identifier	—
Source Entity	Source Type						
Algorithm	—						
Service Quantity Identifier	—						
Pricing Eligibility Criteria	<p>Indicates whether the parameter can be used while defining the pricing eligibility criteria.</p> <p><b>Note:</b> This option does not appear when the <b>Transaction</b> option is selected from the <b>Source Entity</b> list.</p>						

Option Name	Option Description
Price List Eligibility Criteria	Indicates whether the parameter can be used while defining the price list eligibility criteria.  <b>Note:</b> This option does not appear when the <b>Transaction</b> option is selected from the <b>Source Entity</b> list.
Product Eligibility Criteria	Indicates whether the parameter can be used while defining the product eligibility criteria.  <b>Note:</b> This option does not appear when the <b>Algorithm, Service Quantity Identifier, or Transaction</b> option is selected from the <b>Source Entity</b> list.

- **Parameter Values** - Lists the predefined values of the parameter. It contains the following columns in the grid:

Column Name	Column Description
Parameter Value	Displays the parameter value.
Description	Displays the description of the parameter value.

**Note:** The **Parameter Values** section appears only when the **Predefined** option is selected from the **Value Type** list.

### Related Topics

For more information on...	See...
<b>Parameter</b> screen	<a href="#">Parameter (Used for Viewing)</a> on page 316

## Price Item

A bank may offer wide range of services to customers and accordingly charge them fees and/or interest for a service. You can define each charge as a price item in Oracle Revenue Management and Billing. Once a price item is defined, you can define pricing for the price item. The price item pricing can be a standard price defined in the price list or override price that is specific to a person or an account. The system allows you to define price item pricing at various levels in a person hierarchy (for example, at the account level, main customer level, or at the parent customer level). You can also define price item pricing in the account's price list, main customer's price list, parent customer's price list, and price list's parent price list.

You can associate one or more price items with each other, and thereby group them for various reasons, such as reporting, billing, and so on. You can also create a price item bundle and then add price items within the price item bundle. The main objective behind grouping price items or creating price item bundles is to offer discounts based on the volume across price items, facilitate minimum or maximum charge calculations across price items, or offer common price across price items. While associating a price item with the parent price item or adding a price item to the price item bundle, you need to specify how the two price items are related to each other.

The system allows you to define the following types of price item bundle:

- [Regular Bundle](#) on page 288
- [Phantom Bundle](#) on page 292
- [Ratio Bundle](#) on page 290

The system allows you to define price items and price item bundles which are available for only pricing or pricing and billing. If the price item is available for only pricing, you can indicate the type of the price item. The valid values are:

- Rate (i.e. Interest Rate)
- Fees

If the type of a price item is **Rate**, the system calculates and persist the rate for the price item. The rate is persisted only for the price item pricing which is either assigned or inherited by an account. You cannot define a price item bundle when it is available for only pricing and when the price item type is set to **Rate**. When you define a price item or price item bundle which is available for only pricing, the contract type defined in the **Default Contract Type** option type of the **Pricing Configuration (C1\_PRICING)** feature configuration is automatically associated with the price item or price item bundle.

You can associate a price item or price item bundle to one or more divisions. You can assign a price item or price item bundle to an account, person, or price list only when the account, person, or price list belongs to the division to which the price item or price item bundle is associated. You can define a set of characteristics for a price item or price item bundle which are common across divisions or specific to a division. You can associate one or more parameters to a price item. These parameters can then be used for aggregating transactions and defining the price item pricing. Note that you can associate parameters only to regular price item bundles and not to ratio and phantom price item bundles.

## Price Item (Used for Searching)

The **Price Item** screen allows you to search for a price item or price item bundle using various search criteria. It allows you to create and edit a price item or price item bundle. In addition, it allows you to copy a price item bundle only when **Multi Price Parameter** option type of the **Multi Parameter Based Pricing (C1\_PPARM\_FLG)** feature configuration is set to **False**. This screen consists of the following zones:

- [Search Price Item](#) on page 319

### Search Price Item

The **Search Price Item** zone allows you to search for a price item or price item bundle using various search criteria. It contains the following two sections:

- **Search Criteria** – The **Search Criteria** section contains the following fields:

Field Name	Field Description	Mandatory (Yes or No)
Search By	Used to indicate whether you want to search for a price item or price item bundle using the price item details. The valid value is: <ul style="list-style-type: none"> <li>• Price Item Details</li> </ul> <div style="border: 1px solid black; padding: 2px; margin-top: 5px;"><b>Note:</b> By default, the <b>Price Item Details</b> option is selected.</div>	Yes
Price Item	Used to search a particular price item or price item bundle.	No
Description	Used to search a price item or price item bundle with a particular description.	No
Division	Used to search price items or price item bundles which are associated with a particular division. <div style="border: 1px solid black; padding: 2px; margin-top: 5px;"><b>Note:</b> You can only view those divisions to which you have access in the <b>Division</b> list.</div>	No



Field Name	Field Description	Mandatory (Yes or No)
Global Price List	Used to search price items or price item bundles which can be assigned to a global price list. The valid values are: <ul style="list-style-type: none"> <li>• Yes</li> <li>• No</li> </ul>	No
Price Item Usage	Used to search price items or price item bundles which can be used for only pricing or pricing and billing. The valid values are: <ul style="list-style-type: none"> <li>• Pricing</li> <li>• Pricing and Billing</li> </ul> <div style="border: 1px solid black; padding: 2px;"> <p><b>Note:</b> By default, the <b>Pricing and Billing</b> option is selected.</p> </div>	No
Bundle	Used to indicate whether you want to search a price item bundle. The valid values are: <ul style="list-style-type: none"> <li>• Yes</li> <li>• No</li> </ul>	No
Price Item Type	Used to search a particular type of price items or price item bundles. The valid values are: <ul style="list-style-type: none"> <li>• Fees</li> <li>• Rate</li> </ul> <div style="border: 1px solid black; padding: 2px;"> <p><b>Note:</b> This field appears only when you select the <b>Pricing</b> option from the <b>Price Item Usage</b> list.</p> </div>	No

**Note:** You must specify at least one search criterion while searching for a price item or price item bundle.

- **Search Results** – On clicking the **Search** button, the search results appear based on the specified search criteria. The **Search Results** section contains the following columns:

Column Name	Column Description
Price Item Information	Displays information about the price item or price item bundle. <div style="border: 1px solid black; padding: 2px;"> <p><b>Note:</b> It has a link. On clicking the link, the <b>Price Item</b> screen appears where you can view the details of the respective price item or price item bundle.</p> </div>



Column Name	Column Description
Bundle Type	<p>Indicates the type of the price item bundle. If the price item bundle is available for pricing and billing, the valid values are:</p> <ul style="list-style-type: none"> <li>• Phantom</li> <li>• Ratio</li> <li>• Regular</li> </ul> <p>However, if the price item bundle is available for only pricing and the <b>Price Item Type</b> is set to <b>Fees</b>, the valid value is:</p> <ul style="list-style-type: none"> <li>• Regular</li> </ul>
Price Item Type	<p>Indicates the type of the price item or price item bundle. The valid values are:</p> <ul style="list-style-type: none"> <li>• Rate</li> <li>• Fees</li> </ul>
Price Item Usage	<p>Indicates whether the price item or price item bundle is used for only pricing or pricing and billing. The valid values are:</p> <ul style="list-style-type: none"> <li>• Pricing</li> <li>• Pricing and Billing</li> </ul>
Copy	<p>On clicking the <b>Copy</b> () icon, the <b>Price Item</b> screen appears where you can create a new price item or price item bundle using an existing price item or price item bundle.</p>
Price Item Assigned To	<p>On clicking the <b>View</b> () icon in the <b>Price Item Assigned To</b> column, the <b>Price Item Assignments</b> screen appears where you can view the active price lists, persons, and accounts to which the price item or price item bundle is assigned.</p>
Price Item Relationship	<p>On clicking the <b>View</b> () icon in the <b>Price Item Relationship</b> column, the <b>Price Item Relationship</b> screen appears where you can view the list of the price items and price item bundles associated with the parent price item or added to the price item bundle.</p>

**Note:** Pagination is used to display limited number of records in the **Search Results** section. You can use the navigation links, such as **Previous** and **Next** to navigate between pages.

### **Related Topics**

For more information on...	See...
How to search for a price item or price item bundle	<a href="#">Searching for a Price Item or Price Item Bundle</a> on page 322
How to view the details of a price item or price item bundle	<a href="#">Viewing the Price Item or Price Item Bundle Details</a> on page 338
How to copy a price item or price item bundle	<a href="#">Copying a Price Item or Price Item Bundle</a> on page 335
<b>Price Item Assignments</b> screen	<a href="#">Price Item Assignments</a> on page 364
<b>Price Item Relationship</b> screen	<a href="#">Price Item Relationship</a> on page 349

## Searching for a Price Item or Price Item Bundle

### Prerequisites

To search for a price item or price item bundle, you should have:

- Divisions defined in the application
- Price items or price item bundles associated with the division to which the user belongs

### Procedure

To search for a price item or price item bundle:

1. Click the **Menu** link in the **Application** toolbar.  
A list appears.
2. From the **Main** menu, select **Pricing Management** and then click **Price Item**.  
A sub-menu appears.
3. Click the **Search** option from the **Price Item** sub-menu.  
The **Price Item** screen appears.
4. Enter the search criteria in the **Search Price Item** zone depending on whether you want to search for a price item or price item bundle.

**Note:** ORMB search engine supports wildcard search, where you can substitute the percentage (%) symbol as a stand in for any word or letter in a search criteria. You can use the ‘%’ wildcard character in all input fields except the date and ID fields. The ‘%’ wildcard character is suffixed automatically at the end of the partial search criteria. Therefore, you may or may not specify the wildcard character at the end of the partial search criteria. However, you have to prefix the wildcard character manually wherever required.

5. Click **Search**.

A list of price items or price item bundles that meet the search criteria appears in the **Search Results** section.

**Note:** Pagination is used to display limited number of records in the **Search Results** section. You can use the navigation links, such as **Previous** and **Next** to navigate between pages.

### Related Topics

For more information on...	See...
<b>Price Item</b> screen	<a href="#">Price Item (Used for Searching)</a> on page 319
<b>Search Price Item</b> zone	<a href="#">Search Price Item</a> on page 319

## Defining a Price Item or Price Item Bundle

### Prerequisites

To define a price item or price item bundle, you should have:

- Contract types defined in the application
- Value defined for the **Default Contract Type** option type in the **Pricing Configuration (C1\_PRICING)** feature configuration

### Procedure

To define a price item or price item bundle:

1. Click the **Menu** link in the **Application** toolbar.  
A list appears.

- From the **Main** menu, select **Pricing Management** and then click **Price Item**.

A sub-menu appears.

- Click the **Add** option from the **Price Item** sub-menu.

The **Price Item** screen appears. It contains the following sections:

- **Main** - Used to specify basic details about the price item or price item bundle.
- **Parameters** - Used to associate a parameter with the price item or price item bundle. These associated parameters are then used for aggregating transactions and/or for defining the price item pricing.

**Note:**

The **Parameters** section appears in the **Price Item** screen only when the **Multi Price Parameter** option type of the **Multi Parameter Based Pricing (C1\_PPARM\_FLG)** feature configuration is set to **True**.

You cannot associate parameters to ratio and phantom price item bundles. Therefore, while defining the ratio and phantom price item bundles, the **Parameters** section does not appear in the **Price Item** screen.

- **Divisions** - Used to associate the price item or price item bundle with one or more divisions. It also allows you to define division-specific SQIs, division-specific accrual type criteria, and division-specific characteristics for the price item or price item bundle.
- **Price Item Characteristics** - Used to define characteristics (which are applicable across divisions) for the price item or price item bundle.

The **Main** section contains the following fields:

Field Name	Field Description	Mandatory (Yes or No)
Price Item	Used to specify the price item or price item bundle.	Yes
Description	Used to specify the description for the price item or price item bundle.	Yes
Price Item Usage	Used to indicate whether the price item or price item bundle is used for only pricing or pricing and billing. The valid values are: <ul style="list-style-type: none"> <li>• Pricing</li> <li>• Pricing and Billing</li> </ul> <div data-bbox="548 1356 1107 1436" style="border: 1px solid black; padding: 2px;"> <p><b>Note:</b> By default, the <b>Pricing and Billing</b> option is selected.</p> </div>	Yes

Field Name	Field Description	Mandatory (Yes or No)
Price Item Type	<p>Used to indicate the type of the price item or price item bundle. The valid values are:</p> <ul style="list-style-type: none"> <li>• Rate</li> <li>• Fees</li> </ul> <div style="border: 1px solid black; padding: 5px; margin-top: 10px;"> <p><b>Note:</b> By default, the <b>Fees</b> option is selected. This field appears only when you select the <b>Pricing</b> option from the <b>Price Item Usage</b> list. You cannot define a price item bundle when it is available for only pricing and when the price item type is set to <b>Rate</b>.</p> </div>	Yes
Bundle	<p>Used to indicate whether you want to define a price item bundle. The valid values are:</p> <ul style="list-style-type: none"> <li>• Yes</li> <li>• No</li> </ul> <div style="border: 1px solid black; padding: 5px; margin-top: 10px;"> <p><b>Note:</b> By default, the <b>No</b> option is selected.</p> </div>	Yes
Bundle Type	<p>Used to indicate the type of the price item bundle. If the price item bundle is available for pricing and billing, the valid values are:</p> <ul style="list-style-type: none"> <li>• Phantom</li> <li>• Ratio</li> <li>• Regular</li> </ul> <div style="border: 1px solid black; padding: 5px; margin-top: 10px;"> <p><b>Note:</b> This field is enabled only when you select the <b>Pricing and Billing</b> option from the <b>Price Item Usage</b> list and the <b>Yes</b> option from the <b>Bundle</b> list. All the above mentioned values are available in the list when you are defining a price item bundle which is available for pricing and billing. However, when you are defining a price item bundle which is available for only pricing and when the price item type is set to <b>Fees</b>, you can only define a regular price item bundle. Therefore, by default, the value is set to <b>Regular</b> when you select the <b>Pricing</b> option from the <b>Price Item Usage</b> list and the <b>Yes</b> option from the <b>Bundle</b> list. You cannot define a price item bundle when it is available for only pricing and when the price item type is set to <b>Rate</b>.</p> </div>	Yes (Conditional) <div style="border: 1px solid black; padding: 5px; margin-top: 10px;"><b>Note:</b> This field is required when you are creating a price item bundle.</div>

Field Name	Field Description	Mandatory (Yes or No)
Global Price List	Used to indicate whether the price item or price item bundle can be assigned to a global price list. The valid values are: <ul style="list-style-type: none"> <li>• Yes</li> <li>• No</li> </ul> <div style="border: 1px solid black; padding: 2px; margin-top: 5px;"><b>Note:</b> By default, the <b>No</b> option is selected.</div>	Yes
Contract Type	Used to indicate the contract type that you want to associate with the price item or price item bundle. <div style="border: 1px solid black; padding: 2px; margin-top: 5px;"><b>Note:</b> This field appears only when you select the <b>Pricing and Billing</b> option from the <b>Price Item Usage</b> list. The <b>Search</b>  icon appears corresponding to the <b>Contract Type</b> field. On clicking the <b>Search</b> icon, the <b>Contract Type Search</b> window appears.</div>	Yes

**Tip:** Alternatively, you can access the **Price Item** screen by clicking the **Add** button in the **Page Title** area of the **Price Item** screen.

4. Enter the required details in the **Main** section.
5. Associate parameters with the price item or price item bundle, if required.
6. Associate the price item or price item bundle to the required divisions.
7. Define the required division-specific SQIs for the price item or price item bundle.
8. Define division-specific characteristics for the price item or price item bundle, if required.
9. Define division-specific accrual type criteria for the price item or price item bundle, if required.
10. Define characteristics for the price item or price item bundle, if required.
11. Click **Save**.

The price item is defined.

**Note:** When you define a price item or price item bundle which is available for only pricing, the contract type defined in the **Default Contract Type** option type of the **Pricing Configuration (C1\_PRICING)** feature configuration is automatically associated to the price item or price item bundle.

### Related Topics

For more information on...	See...
<b>Price Item</b> screen	<a href="#">Price Item (Used for Searching)</a> on page 319
<b>Search Price Item</b> zone	<a href="#">Search Price Item</a> on page 319
How to associate a price item or price item bundle with a parameter	<a href="#">Associating a Parameter with a Price Item or Price Item Bundle</a> on page 326
How to associate a price item or price item bundle with a division	<a href="#">Associating a Price Item or Price Item Bundle with a Division</a> on page 329

For more information on...	See...
How to associate a price item or price item bundle with an SQI in a particular division	<a href="#">Defining Division-Specific SQIs for a Price Item or Price Item Bundle</a> on page 330
How to associate a price item or price item bundle with an accrual type criteria in a particular division	<a href="#">Defining Division-Specific Accrual Type Criteria for a Price Item or Price Item Bundle</a> on page 333
How to define a characteristic for a price item or price item bundle in a particular division	<a href="#">Defining Division-Specific Characteristics for a Price Item or Price Item Bundle</a> on page 331
How to define a characteristic for a price item or price item bundle	<a href="#">Defining a Characteristic for a Price Item or Price Item Bundle</a> on page 334
How to set the <b>Pricing Configuration (C1_PRICING)</b> feature configuration	<a href="#">Setting the C1_PRICING Feature Configuration</a>

## Associating a Parameter with a Price Item or Price Item Bundle

### Prerequisites

To associate a parameter with a price item or price item bundle, you should have:

- Parameters defined in the application (where the **Price Item** option is selected in the **Parameter Usage** section)

### Procedure

To associate a parameter with a price item or price item bundle:

1. Click the **Parameters** or **Show All** link in the **Section** pane when you are defining, editing, or copying a price item or price item bundle.

The **Parameters** section appears. It contains the following fields in a grid:

Field Name	Field Description	Mandatory (Yes or No)
Effective Start Date	Used to specify the date from when the parameter is effective for the price item or price item bundle.	Yes
Effective End Date	Used to specify the date till when the parameter is effective for the price item or price item bundle.	No
Parameter	Used to indicate the parameter that you want to associate with the price item or price item bundle.  <div style="border: 1px solid black; padding: 5px;"> <p><b>Note:</b></p> <p>The <b>Search</b>  icon appears corresponding to the <b>Parameter</b> field. On clicking the <b>Search</b> icon, the <b>Parameter Search</b> window appears.</p> <p>In the <b>Parameter Search</b> window, the system allows you to search only those parameters where the parameter usage is set to <b>Price Item</b>.</p> </div>	Yes
Business Label	Used to specify a business label for the parameter. If the business label is defined for a parameter, the business label appears instead of the parameter name.	No
Display Order	Used to indicate the order in which the parameter and its value should be displayed in the price item parameter information string across the application.	Yes

Field Name	Field Description	Mandatory (Yes or No)
Parameter Usage	Used to indicate whether you want to use the parameter for aggregation and/or for defining the price item pricing. The valid values are: <ul style="list-style-type: none"> <li>• <b>Aggregation</b> – Indicates that you want to use the parameter for aggregating transactions.</li> <li>• <b>Pricing</b> – Indicates that you want to use the parameter for aggregating transactions and defining the price item pricing.</li> </ul>	Yes
Mandatory	Used to indicate whether the parameter is mandatory while defining the price item pricing.	No
Priority	Used to indicate the priority in which optional parameters should be considered while determining best fit price for the price item or price item bundle.  <b>Note:</b> This field is disabled when the <b>Mandatory</b> option is selected.	Yes (Conditional)  <b>Note:</b> This field is required when the <b>Mandatory</b> option is not selected.

**Note:**

The **Parameters** section appears in the **Price Item** screen only when the **Multi Price Parameter** option type of the **Multi Parameter Based Pricing (C1\_PPARM\_FLG)** feature configuration is set to **True**.

You cannot associate parameters to ratio and phantom price item bundles. Therefore, while defining, editing, or copying ratio and phantom price item bundles, the **Parameters** section does not appear in the **Price Item** screen.

- Enter the required details in the **Parameters** section.
- If you want to associate more than one parameter with the price item or price item bundle, click the **Add (+)** icon and then repeat steps 2.

**Note:**

However, if you want to remove a parameter from the price item or price item bundle, click the **Delete (🗑)** icon corresponding to the parameter. You can edit the parameter details and remove a parameter from the price item or price item bundle only when the parameter or any other parameter from the same date range is not yet used for aggregation or for defining the price item pricing.

You can add a parameter which will be used for aggregation (in other words, where the **Parameter Usage** field is set to **Aggregation**) anytime, whenever required. However, you can add a parameter which will be used for pricing (in other words, where the **Parameter Usage** field is set to **Pricing**) only when any other parameter from the same date range is not yet used for aggregation or for defining the price item pricing.

- Click **Save**.

The parameters are associated with the price item or price item bundle.

**Note:** The priority for all parameters which are mandatory is set to 0.

**Related Topics**

For more information on...	See...
How to define a price item or price item bundle	<a href="#">Defining a Price Item or Price Item Bundle</a> on page 322
How to edit a price item or price item bundle	<a href="#">Editing a Price Item or Price Item Bundle</a> on page 346
How to copy a price item or price item bundle	<a href="#">Copying a Price Item or Price Item Bundle</a> on page 335
How to define valid predefined parameter values for a price item or price item bundle	<a href="#">Defining Valid Predefined Parameter Values for a Price Item or Price Item Bundle</a> on page 328

## Defining Valid Predefined Parameter Values for a Price Item or Price Item Bundle

### Prerequisites

To define valid predefined parameter values for a price item or price item bundle, you should have:

- Values defined for the predefined parameter which is associated with the price item or price item bundle

### Procedure

To define valid predefined parameter values for a price item or price item bundle:

1. Click the **Parameters** or **Show All** link in the **Section** pane when you are defining, editing, or copying a price item or price item bundle.

The **Parameters** section appears.

2. Click the **Add** () icon in the **Parameter** column corresponding to the predefined parameter for which you want to define valid values for the price item or price item bundle.

The following field appears in the grid:

Field Name	Field Description	Mandatory (Yes or No)
Parameter Value	<p>Used to indicate the predefined parameter value which you can use for the price item or price item bundle while defining the pricing.</p> <div style="border: 1px solid black; padding: 5px;"> <p><b>Note:</b></p> <p>The <b>Search</b> () icon appears corresponding to the <b>Parameter Value</b> field. On clicking the <b>Search</b> icon, the <b>Predefined Parameter Value Search</b> window appears.</p> <p>On specifying the valid predefined parameter value for a price item or price item bundle, the description of the valid predefined parameter value appears corresponding to the <b>Parameter Value</b> field.</p> </div>	<p>Yes (Conditional)</p> <div style="border: 1px solid black; padding: 5px;"> <p><b>Note:</b> This field is required when you are defining valid predefined parameter values for the price item or price item bundle.</p> </div>

3. Select the predefined parameter value from the respective field.
4. If you want to define more than one valid predefined parameter value for the price item or price item bundle, click the **Add** () icon and then repeat step 3.



**Note:** However, if you want to remove a valid predefined parameter value from the price item or price item bundle, click the **Delete** () icon corresponding to the parameter value.

- Click **Save**.

The valid predefined parameter values are defined for the price item or price item bundle.

### **Related Topics**

For more information on...	See...
How to associate a parameter with a price item or price item bundle	<a href="#">Associating a Parameter with a Price Item or Price Item Bundle</a> on page 326

## **Associating a Price Item or Price Item Bundle with a Division**

### **Prerequisites**

To associate a price item or price item bundle with a division, you should have:



- Divisions defined in the application

### **Procedure**

To associate a price item or price item bundle with a division:

- Click the **Divisions** or **Show All** link in the **Section** pane when you are defining, editing, or copying a price item or price item bundle.

The **Divisions** section appears. It contains the following fields in a grid:

Field Name	Field Description	Mandatory (Yes or No)
SQIs	On clicking the <b>Add</b> (  ) icon, you can define division-specific SQIs for the price item or price item bundle.	No
Division Characteristics	On clicking the <b>Add</b> (  ) icon, you can define division-specific characteristics for the price item or price item bundle.	No
Accrual Type Criteria	On clicking the <b>Add</b> (  ) icon, you can define division-specific accrual type criteria for the price item or price item bundle.	No
Division	Used to indicate the division to which you want to associate the price item or price item bundle.  <b>Note:</b> You can only view those divisions to which you have access in the <b>Division</b> list.	Yes

- Enter the required details in the **Divisions** section.
- If you want to associate the price item or price item bundle with more than one division, click the **Add** () icon and then repeat step 2.

**Note:** However, if you want to remove the price item or price item bundle from a division, click the **Delete** () icon corresponding to the division.

- Define division-specific SQIs for the price item or price item bundle, if required.

5. Define division-specific characteristics for the price item or price item bundle, if required.
6. Define division-specific accrual type criteria for the price item or price item bundle, if required.
7. Click **Save**.

The price item or price item bundle is associated to the division.

**Tip:** Alternatively, you can associate a price item or price item bundle to a division using the **Division** screen.

### **Related Topics**

<b>For more information on...</b>	<b>See...</b>
How to define a price item or price item bundle	<a href="#">Defining a Price Item or Price Item Bundle</a> on page 322
How to edit a price item or price item bundle	<a href="#">Editing a Price Item or Price Item Bundle</a> on page 346
How to copy a price item or price item bundle	<a href="#">Copying a Price Item or Price Item Bundle</a> on page 335
How to define division-specific SQIs for a price item or price item bundle	<a href="#">Defining Division-Specific SQIs for a Price Item or Price Item Bundle</a> on page 330
How to define division-specific characteristics for a price item or price item bundle	<a href="#">Defining Division-Specific Characteristics for a Price Item or Price Item Bundle</a> on page 331
How to define division-specific accrual type criteria for a price item or price item bundle	<a href="#">Defining Division-Specific Accrual Type Criteria for a Price Item or Price Item Bundle</a> on page 333

## **Defining Division-Specific SQIs for a Price Item or Price Item Bundle**

### **Prerequisites**

To define division-specific SQIs for a price item or price item bundle, you should have:

- SQIs defined in the application
- Price items or price item bundles associated with the division to which the user belongs

### **Procedure**

To define division-specific SQIs for a price item or price item bundle:

1. Click the **Divisions** or **Show All** link in the **Section** pane when you are defining, editing, or copying a price item or price item bundle.

The **Divisions** section appears.

2. Click the **Add** (  ) icon in the **SQIs** column corresponding to the division for which you want to define division-specific price item or price item bundle SQIs.

The following field appears in the grid:

Field Name	Field Description	Mandatory (Yes or No)
SQI	Used to indicate the SQI to which you want to associate the price item or price item bundle in the division.  <div style="border: 1px solid black; padding: 5px;"> <p><b>Note:</b></p> <p>The <b>Search</b>  icon appears corresponding to the <b>SQI</b> field. On clicking the <b>Search</b> icon, the <b>Service Quantity Identifier Search</b> window appears.</p> <p>On indicating the SQI, the description of the SQI appears corresponding to the <b>SQI</b> field.</p> </div>	Yes (Conditional)  <div style="border: 1px solid black; padding: 5px;"> <p><b>Note:</b> This field is required when you are defining a division-specific SQI for the price item or price item bundle.</p> </div>

- Enter the required details in the **Divisions** section.
- If you want to define more than one division-specific SQI for the price item or price item bundle, click the **Add**  icon and then repeat step 3.

**Note:** However, if you want to remove a division-specific SQI from the price item or price item bundle, click the **Delete**  icon corresponding to the SQI.

- Click **Save**.

The division-specific SQIs are defined for the price item or price item bundle.

### **Related Topics**

For more information on...	See...
How to define a price item or price item bundle	<a href="#">Defining a Price Item or Price Item Bundle</a> on page 322
How to edit a price item or price item bundle	<a href="#">Editing a Price Item or Price Item Bundle</a> on page 346
How to copy a price item or price item bundle	<a href="#">Copying a Price Item or Price Item Bundle</a> on page 335
How to associate a price item or price item bundle with a division	<a href="#">Associating a Price Item or Price Item Bundle with a Division</a> on page 329

## **Defining Division-Specific Characteristics for a Price Item or Price Item Bundle**

### **Prerequisites**

To define division-specific characteristics for a price item or price item bundle, you should have:

- Characteristic types defined in the application (where the characteristic entity is set to **Division/Price Item Combination**)
- Price items or price item bundles associated to the division to which the user belongs

### **Procedure**

To define division-specific characteristics for a price item or price item bundle:

- Click the **Divisions** or **Show All** link in the **Section** pane when you are defining, editing, or copying a price item or price item bundle.

The **Divisions** section appears.

- Click the **Add** () icon in the **Division Characteristics** column corresponding to the division for which you want to define division-specific price item or price item bundle characteristics.

The following fields appear in the grid:

Field Name	Field Description	Mandatory (Yes or No)
Effective Date	Used to specify the date from when the price item or price item bundle characteristic is effective for the division.	Yes (Conditional)  <b>Note:</b> This field is required when you are defining a division-specific characteristic for the price item or price item bundle.
Characteristic Type	Used to indicate the characteristic type.  <b>Note:</b> The list includes only those characteristic types where the characteristic entity is set to <b>Division/Price Item Combination</b> .	Yes (Conditional)  <b>Note:</b> This field is required when you are defining a division-specific characteristic for the price item or price item bundle.
Characteristic Value	Used to specify the value for the characteristic type.  <b>Note:</b> If you select a predefined characteristic type, the <b>Search</b> (  ) icon appears corresponding to the <b>Characteristic Value</b> field. On clicking the <b>Search</b> icon, the <b>Predefined Characteristic Search</b> window appears.  On specifying the value for a predefined characteristic type, the description of the characteristic value appears corresponding to the <b>Characteristic Value</b> field.	Yes (Conditional)  <b>Note:</b> This field is required when you are defining a division-specific characteristic for the price item or price item bundle.

- Enter the required details in the **Divisions** section.
- If you want to define more than one division-specific characteristic for the price item or price item bundle, click the **Add** () icon and then repeat step 3.

**Note:** However, if you want to remove a division-specific characteristic from the price item or price item bundle, click the **Delete** () icon corresponding to the characteristic.

- Click **Save**.

The division-specific characteristics are defined for the price item or price item bundle.

### **Related Topics**

For more information on...	See...
How to define a price item or price item bundle	<a href="#">Defining a Price Item or Price Item Bundle</a> on page 322
How to edit a price item or price item bundle	<a href="#">Editing a Price Item or Price Item Bundle</a> on page 346
How to copy a price item or price item bundle	<a href="#">Copying a Price Item or Price Item Bundle</a> on page 335

<b>For more information on...</b>	<b>See...</b>
How to associate a price item or price item bundle with a division	<a href="#">Associating a Price Item or Price Item Bundle with a Division</a> on page 329

## Defining Division-Specific Accrual Type Criteria for a Price Item or Price Item Bundle

### Prerequisites

To define division-specific accrual type criteria for a price item or price item bundle, you should have:

- Accrual types defined in the application
- Price items or price item bundles associated with the division to which the user belongs

### Procedure

To define division-specific accrual type criteria for a price item or price item bundle:

1. Click the **Divisions** or **Show All** link in the **Section** pane when you are defining, editing, or copying a price item or price item bundle.

The **Divisions** section appears.

2. Click the **Add** () icon in the **Accrual Type Criteria** column corresponding to the division for which you want to define a division-specific price item or price item bundle accrual type criteria.

The following field appears in the grid:

Field Name	Field Description	Mandatory (Yes or No)
Accrual Type Criteria	<p>Used to indicate the accrual type to which you want to associate the price item or price item bundle in the division. The valid values are:</p> <ul style="list-style-type: none"> <li>• <b>Actual</b> - Used to create accrual for the price item or price item bundle based on the current trial bill data in a division.</li> <li>• <b>Historical</b> - Used to create accrual for the price item or price item bundle based on the historical bill data in a division.</li> <li>• <b>Not Applicable</b> - Used to create accrual for the price item or price item bundle based on the current trial bill data as well as the historical bill data in a division.</li> </ul> <p><b>Note:</b> By default, the <b>Not Applicable</b> option is selected.</p>	<p>Yes (Conditional)</p> <p><b>Note:</b> This field is required when you are defining a division-specific accrual type criteria for the price item or price item bundle.</p>

3. Enter the required details in the **Divisions** section.
4. If you want to define more than one division-specific accrual type criteria for the price item or price item bundle, click the **Add** () icon corresponding to the respective division and then repeat step 3.

**Note:** However, if you want to remove a division-specific accrual type criteria from the price item or price item bundle, click the **Delete** () icon corresponding to the respective division.

5. Click **Save**.

The division-specific accrual type criteria are defined for the price item or price item bundle.

**Related Topics**

For more information on...	See...
How to define a price item or price item bundle	<a href="#">Defining a Price Item or Price Item Bundle</a> on page 322
How to edit a price item or price item bundle	<a href="#">Editing a Price Item or Price Item Bundle</a> on page 346
How to copy a price item or price item bundle	<a href="#">Copying a Price Item or Price Item Bundle</a> on page 335
How to associate a price item or price item bundle with a division	<a href="#">Associating a Price Item or Price Item Bundle with a Division</a> on page 329

**Defining a Characteristic for a Price Item or Price Item Bundle****Prerequisites**

To define a characteristic for a price item or price item bundle, you should have:

- Characteristic types defined in the application (where the characteristic entity is set to **Price Item**)

**Procedure**

To define a characteristic for a price item or price item bundle:

1. Click the **Price Item Characteristics** or **Show All** link in the **Section** pane when you are defining, editing, or copying a price item or price item bundle.

The **Price Item Characteristics** section appears. It contains the following fields in a grid:

Field Name	Field Description	Mandatory (Yes or No)
Effective Date	Used to specify the date from when the characteristic is effective for the price item or price item bundle.	Yes (Conditional) <b>Note:</b> This field is required when you are defining a characteristic for the price item or price item bundle.
Characteristic Type	Used to indicate the characteristic type. <b>Note:</b> The list includes only those characteristic types where the characteristic entity is set to <b>Price Item</b> .	Yes (Conditional) <b>Note:</b> This field is required when you are defining a characteristic for the price item or price item bundle.

Field Name	Field Description	Mandatory (Yes or No)
Characteristic Value	<p>Used to specify the value for the characteristic type.</p> <p><b>Note:</b></p> <p>If you select a predefined characteristic type, the <b>Search</b>  icon appears corresponding to the <b>Characteristic Value</b> field. On clicking the <b>Search</b> icon, the <b>Predefined Characteristic Search</b> window appears.</p> <p>On specifying the value for a predefined characteristic type, the description of the characteristic value appears corresponding to the <b>Characteristic Value</b> field.</p>	<p>Yes (Conditional)</p> <p><b>Note:</b> This field is required when you are defining a characteristic for the price item or price item bundle.</p>

- Enter the required details in the **Price Item Characteristics** section.
- If you want to define more than one characteristic for the price item or price item bundle, click the **Add**  icon and then repeat step 2.

**Note:** However, if you want to remove a characteristic from the price item or price item bundle, click the **Delete**  icon corresponding to the characteristic.

- Click **Save**.

The characteristics are defined for the price item or price item bundle.

### **Related Topics**

For more information on...	See...
How to define a price item or price item bundle	<a href="#">Defining a Price Item or Price Item Bundle</a> on page 322
How to edit a price item or price item bundle	<a href="#">Editing a Price Item or Price Item Bundle</a> on page 346
How to copy a price item or price item bundle	<a href="#">Copying a Price Item or Price Item Bundle</a> on page 335

### **Copying a Price Item or Price Item Bundle**

Instead of creating a price item or price item bundle from scratch, you can create a new price item or price item bundle using an existing price item or price item bundle. This is possible through copying a price item or price item bundle. On copying a price item or price item bundle, the details including the parameters, divisions, division-specific characteristics, division-specific SQIs, and characteristics are copied to the new price item or price item bundle. You can then edit the details, if required.

### **Prerequisites**

To copy a price item or price item bundle, you should have:

- Price item or price item bundle (whose copy you want to create) defined in the application
- Price item or price item bundle (whose copy you want to create) associated with the division to which the user belongs
- Contract types defined in the application
- Value defined for the **Default Contract Type** option type in the **Pricing Configuration (C1\_PRICING)** feature configuration

**Procedure**

To copy a price item or price item bundle:

1. Search for the price item or price item bundle in the **Price Item** screen.
2. In the **Search Results** section, click the **Copy**  icon in the **Copy** column corresponding to the price item or price item bundle using which you want to define a new price item or price item bundle.

The **Price Item** screen appears. It contains the following sections:

- **Main** – Used to specify basic details about the price item or price item bundle.
- **Parameters** – Used to associate a parameter with the price item or price item bundle. These associated parameters are then used for aggregating transactions and/or for defining the price item pricing.

**Note:**

The **Parameters** section appears in the **Price Item** screen only when the **Multi Price Parameter** option type of the **Multi Parameter Based Pricing (C1\_PPARM\_FLG)** feature configuration is set to **True**.

You cannot associate parameters to ratio and phantom price item bundles. Therefore, while defining ratio and phantom price item bundles, the **Parameters** section does not appear in the **Price Item** screen.

- **Divisions** – Used to associate the price item or price item bundle with one or more divisions. It also allows you to define division-specific SQIs, division-specific accrual type criteria, and division-specific characteristics for the price item or price item bundle.
- **Price Item Characteristics** – Used to define characteristics (which are applicable across divisions) for the price item or price item bundle.

The **Main** section contains the following fields:

Field Name	Field Description	Mandatory (Yes or No)
Price Item	Used to specify the price item or price item bundle.	Yes
Description	Used to specify the description for the price item or price item bundle.	Yes
Price Item Usage	Used to indicate whether the price item or price item bundle is used for only pricing or pricing and billing. The valid values are: <ul style="list-style-type: none"> <li>• Pricing</li> <li>• Pricing and Billing</li> </ul>	Yes
Price Item Type	Used to indicate the type of the price item or price item bundle. The valid values are: <ul style="list-style-type: none"> <li>• Rate</li> <li>• Fees</li> </ul> <div data-bbox="548 1640 1105 1892" style="border: 1px solid black; padding: 5px;"> <p><b>Note:</b></p> <p>This field appears only when you select the <b>Pricing</b> option from the <b>Price Item Usage</b> list.</p> <p>You cannot define a price item bundle when it is available for only pricing and when the price item type is set to <b>Rate</b>.</p> </div>	Yes



Field Name	Field Description	Mandatory (Yes or No)
Bundle	Used to indicate whether you want to define a price item bundle. The valid values are: <ul style="list-style-type: none"> <li>• Yes</li> <li>• No</li> </ul>	Yes
Bundle Type	Used to indicate the type of the price item bundle. The valid values are: <ul style="list-style-type: none"> <li>• Phantom</li> <li>• Ratio</li> <li>• Regular</li> </ul> <div style="border: 1px solid black; padding: 5px;"> <p><b>Note:</b> This field is enabled only when you select the <b>Pricing and Billing</b> option from the <b>Price Item Usage</b> list and the <b>Yes</b> option from the <b>Bundle</b> list.</p> <p>All the above mentioned values are available in the list when you are defining a price item bundle which is available for pricing and billing. However, when you are defining a price item bundle which is available for only pricing and when the price item type is set to <b>Fees</b>, you can only define a regular price item bundle. Therefore, by default, the value is set to <b>Regular</b> when you select the <b>Pricing</b> option from the <b>Price Item Usage</b> list and the <b>Yes</b> option from the <b>Bundle</b> list.</p> <p>You cannot define a price item bundle when it is available for only pricing and when the price item type is set to <b>Rate</b>.</p> </div>	Yes (Conditional) <div style="border: 1px solid black; padding: 5px; margin-top: 10px;"> <p><b>Note:</b> This field is required when you are creating a price item bundle.</p> </div>
Global Price List	Used to indicate whether the price item or price item bundle can be assigned to a global price list. The valid values are: <ul style="list-style-type: none"> <li>• Yes</li> <li>• No</li> </ul>	Yes
Contract Type	Used to indicate the contract type that you want to associate with the price item or price item bundle. <div style="border: 1px solid black; padding: 5px; margin-top: 10px;"> <p><b>Note:</b> This field appears only when you select the <b>Pricing and Billing</b> option from the <b>Price Item Usage</b> list.</p> <p>The <b>Search</b>  icon appears corresponding to the <b>Contract Type</b> field. On clicking the <b>Search</b> icon, the <b>Contract Type Search</b> window appears.</p> </div>	Yes

3. Enter the required details in the **Main** section.
4. Associate, edit, or disassociate parameters from the price item or price item bundle, if required.

5. Associate or disassociate the price item or price item bundle from the required divisions.
6. Define or remove the division-specific SQIs from the price item or price item bundle, if required.
7. Define or remove the division-specific characteristics for the price item or price item bundle, if required.
8. Define, edit, or remove the division-specific accrual type criteria for the price item or price item bundle, if required.
9. Define, edit, or remove characteristics from the price item or price item bundle, if required.
10. Click **Save**.

The new price item is defined.

**Note:**

When you define a new price item or price item bundle which is available for only pricing, the contract type defined in the **Default Contract Type** option type of the **Pricing Configuration (C1\_PRICING)** feature configuration is automatically associated to the price item or price item bundle.

The system allows you to add a price item to the new price item bundle only when:

- Price item and price item bundle (whose copy you are creating) are associated to the same contract type.
- Price item is associated with the division to which the price item bundle (whose copy you are creating) is associated.
- Another price item bundle with the same price item, relationship type, and date range combination does not exist in the system.

**Related Topics**

For more information on...	See...
How to search for a price item or price item bundle	<a href="#">Searching for a Price Item or Price Item Bundle</a> on page 322
How to associate a parameter with a price item or price item bundle	<a href="#">Associating a Parameter with a Price Item or Price Item Bundle</a> on page 326
How to associate a price item or price item bundle with a division	<a href="#">Associating a Price Item or Price Item Bundle with a Division</a> on page 329
How to define division-specific SQIs for a price item or price item bundle	<a href="#">Defining Division-Specific SQIs for a Price Item or Price Item Bundle</a> on page 330
How to define division-specific characteristics for a price item or price item bundle	<a href="#">Defining Division-Specific Characteristics for a Price Item or Price Item Bundle</a> on page 331
How to define division-specific accrual type criteria for a price item or price item bundle	<a href="#">Defining Division-Specific Accrual Type Criteria for a Price Item or Price Item Bundle</a> on page 333
How to define characteristics for a price item or price item bundle	<a href="#">Defining a Characteristic for a Price Item or Price Item Bundle</a> on page 334
How to set the <b>Pricing Configuration (C1_PRICING)</b> feature configuration	<a href="#">Setting the C1_PRICING Feature Configuration</a>

**Viewing the Price Item or Price Item Bundle Details**

**Procedure**

To view the details of a price item or price item bundle:

1. Search for the price item or price item bundle in the **Price Item** screen.

- In the **Search Results** section, click the link in the **Price Item Information** column corresponding to the price item or price item bundle whose details you want to view.

The **Price Item** screen appears. It contains the following zones:

- [Price Item](#) on page 340
  - [Parameters](#) on page 342
  - [Predefined Parameter Values for Price Item](#) on page 342
  - [Divisions](#) on page 343
  - [Division-Specific SQIs for Price Item](#) on page 343
  - [Division-Specific Characteristics for Price Item](#) on page 344
  - [Division-Specific Accrual Type Criteria for Price Item](#) on page 344
  - [Price Item Relationship](#) on page 345
- View the basic details and characteristics of the price item or price item bundle in the **Price Item** zone.
  - View the parameters associated with the price item or price item bundle in the **Parameters** zone.
  - View the valid predefined parameter values of the price item or price item bundle in the **Predefined Parameter Values for Price Item** zone.
  - View the divisions to which the price item or price item bundle is associated in the **Divisions** zone.
  - View the division-specific SQIs of the price item or price item bundle in the **Division-Specific SQIs for Price Item** zone.
  - View the division-specific characteristics of the price item or price item bundle in the **Division-Specific Characteristics for Price Item** zone.
  - View the division-specific accrual type criteria of the price item or price item bundle in the **Division-Specific Accrual Type Criteria for Price Item** zone.
  - View the price items or price item bundles related to the parent price item or price item bundle in the **Price Item Relationship** zone.

### Related Topics

For more information on...	See...
How to search for a price item or price item bundle	<a href="#">Searching for a Price Item or Price Item Bundle</a> on page 322
<b>Price Item</b> screen	<a href="#">Price Item (Used for Viewing)</a> on page 339

## Price Item (Used for Viewing)

The **Price Item** screen allows you to view the details of the price item or price item bundle. It also allows you to edit the details of the price item or price item bundle. It contains the following zones:

- **Price Item** – Displays the basic details of the price item or price item bundle.
- **Parameters** – Lists the parameters which are associated with the price item or price item bundle.
- **Predefined Parameter Values for Price Item** – Lists the predefined parameter values which are valid for the price item or price item bundle.

**Note:** By default, the **Predefined Parameter Values for Price Item** zone does not appear in the **Price Item** screen. It appears only when you click the **Broadcast**  icon corresponding to a parameter in the **Parameters** zone.

- **Divisions** – Lists the divisions to which the price item or price item bundle is associated.
- **Division-Specific SQIs for Price Item** – Lists the SQIs to which the price item or price item bundle is associated in the respective division.

**Note:** By default, the **Division-Specific SQIs for Price Item** zone does not appear in the **Price Item** screen. It appears only when you click the **Broadcast**  icon corresponding to a division in the **Divisions** zone.

- **Division-Specific Characteristics for Price Item** – Lists the characteristics which are defined for the price item or price item bundle in the respective division.

**Note:** By default, the **Division-Specific Characteristics for Price Item** zone does not appear in the **Price Item** screen. It appears only when you click the **Broadcast**  icon corresponding to a division in the **Divisions** zone.

- **Division-Specific Accrual Type Criteria for Price Item** – Indicates the accrual type to which the price item or price item bundle is associated in the respective division.

**Note:** By default, the **Division-Specific Accrual Type Criteria for Price Item** zone does not appear in the **Price Item** screen. It appears only when you click the **Broadcast**  icon corresponding to a division in the **Divisions** zone.

- **Price Item Relationship** – Lists the price items or price item bundles which are associated with the parent price item or added in the price item bundle.

## Price Item

The **Price Item** zone displays the details of the price item or price item bundle. It contains the following sections:

- **Main** – Displays basic information about the price item or price item bundle. It contains the following fields:

Field Name	Field Description
Price Item	Displays information about the price item or price item bundle.
Description	Displays the description of the price item or price item bundle.
Price Item Usage	Indicates whether the price item or price item bundle is used for only pricing or pricing and billing. The valid values are: <ul style="list-style-type: none"> <li>• Pricing</li> <li>• Pricing and Billing</li> </ul>
Price Item Type	Indicates the type of the price item or price item bundle. The valid values are: <ul style="list-style-type: none"> <li>• Rate</li> <li>• Fees</li> </ul> <p><b>Note:</b> This field appears only when you select the <b>Pricing</b> option from the <b>Price Item Usage</b> list.</p>
Bundle	Indicates whether the price item is a bundle. The valid values are: <ul style="list-style-type: none"> <li>• Yes</li> <li>• No</li> </ul>

Field Name	Field Description
Bundle Type	<p>Indicates the type of the price item bundle. The valid values are:</p> <ul style="list-style-type: none"> <li>• Phantom</li> <li>• Ratio</li> <li>• Regular</li> </ul> <p><b>Note:</b> This field appears only when you select the <b>Yes</b> option from the <b>Bundle</b> list.</p>
Global Price List	<p>Indicates whether the price item or price item bundle is assigned to a global price list. The valid values are:</p> <ul style="list-style-type: none"> <li>• Yes</li> <li>• No</li> </ul>
Contract Type	Displays the contract type to which the price item or price item bundle is associated.

- **Price Item Characteristics** – Lists the characteristics defined for the price item or price item bundle. It contains the following columns:

Column Name	Column Description
Effective Date	Displays the date from when the characteristic is effective for the price item or price item bundle.
Characteristic Type	Indicates the characteristic type.
Characteristic Value	Displays the value of the characteristic type.

- **Record Actions** – This section contains the following button:

Button Name	Button Description
Edit	Used to edit the details of the price item or price item bundle.

- **Record Information** – This section contains the following field:

Field Name	Field Description
Business Object	<p>Indicates the business object using which the price item or price item bundle is created. In addition, a context menu appears corresponding to this field which helps in navigating to other screens in the application.</p> <p><b>Note:</b> It has a link. On clicking the link, the <b>Business Object</b> screen appears where you can view the details of the respective business object.</p>

### Related Topics

For more information on...	See...
Price Item screen	<a href="#">Price Item (Used for Viewing)</a> on page 339
How to edit a price item or price item bundle	<a href="#">Editing a Price Item or Price Item Bundle</a> on page 346

## Parameters

The **Parameters** zone lists the parameters to which the price item or price item bundle is associated. It contains the following columns:

Column Name	Column Description
Effective Start Date	Displays the date from when the parameter is effective for the price item or price item bundle.
Effective End Date	Displays the date till when the parameter is effective for the price item or price item bundle.
Parameter	Indicates the parameter to which the price item or price item bundle is associated. <b>Note:</b> It has a link. On clicking the link, the <b>Parameter</b> screen appears where you can view the details of the respective parameter.
Business Label	Displays the business label of the parameter. If the business label is defined for a parameter, the business label appears instead of the parameter name.
Display Order	Indicates the order in which the parameter and its value should be displayed in the price item parameter information string across the application.
Parameter Usage	Indicates whether the parameter is used for aggregation and/or for defining the pricing of the price item or price item bundle. The valid values are: <ul style="list-style-type: none"> <li>• <b>Aggregation</b> – Indicates that the parameter is used for aggregating transactions.</li> <li>• <b>Pricing</b> – Indicates that the parameter is used for aggregating transactions and defining the price item pricing.</li> </ul>
Mandatory	Indicates whether the parameter is mandatory while defining the price item pricing.
Priority	Indicates the priority in which optional parameters should be considered while determining best fit price for the price item or price item bundle.

On clicking the **Broadcast**  icon corresponding to a parameter, the **Predefined Parameter Values for Price Item** zone appears where you can view the valid predefined parameter values of the price item or price item bundle.

### Related Topics

For more information on...	See...
<b>Price Item</b> screen	<a href="#">Price Item (Used for Viewing)</a> on page 339
<b>Predefined Parameter Values</b> zone	<a href="#">Defining Valid Predefined Parameter Values for a Price Item or Price Item Bundle</a> on page 328

### Predefined Parameter Values for Price Item

The **Predefined Parameter Values for Price Item** zone lists the predefined parameter values which are valid for the price item or price item bundle. It contains the following columns:

Column Name	Column Description
Parameter Value	Displays the predefined parameter value.
Description	Displays the description of the predefined parameter value.

By default, the **Predefined Parameter Values for Price Item** zone does not appear in the **Price Item** screen. It appears only when you click the **Broadcast**  icon corresponding to a parameter in the **Parameters** zone.

### Related Topics

For more information on...	See...
<b>Price Item</b> screen	<a href="#">Price Item (Used for Viewing)</a> on page 339
<b>Parameters</b> zone	<a href="#">Parameters</a> on page 342

### Divisions

The **Divisions** zone lists the divisions to which the price item or price item bundle is associated. It contains the following column:

Column Name	Column Description
Division	Indicates the division to which the price item or price item bundle is associated.  <b>Note:</b> It has a link. On clicking the link, the <b>Division</b> screen appears where you can view the details of the respective division.

On clicking the **Broadcast**  icon corresponding to a division, the **Division-Specific SQIs for Price Item**, **Division-Specific Characteristics for Price Item**, and **Division-Specific Accrual Type Criteria for Price Item** zones appear.

You can filter the list using the **Division** field available in the **Filter** area. By default, the **Filter** area is hidden. You can view the **Filter** area by clicking the **Filters**  icon in the upper right corner of this zone.

### Related Topics

For more information on...	See...
<b>Price Item</b> screen	<a href="#">Price Item (Used for Viewing)</a> on page 339
<b>Division-Specific SQIs for Price Item</b> zone	<a href="#">Division-Specific SQIs for Price Item</a> on page 343
<b>Division-Specific Characteristics for Price Item</b> zone	<a href="#">Division-Specific Characteristics for Price Item</a> on page 344
<b>Division-Specific Accrual Type Criteria for Price Item</b>	<a href="#">Division-Specific Accrual Type Criteria for Price Item</a> on page 344

### Division-Specific SQIs for Price Item

The **Division-Specific SQIs for Price Item** zone lists the SQIs to which the price item or price item bundle is associated in a specific division. It contains the following column:

Column Name	Column Description
SQI	Indicates the SQI to which the price item or price item bundle is associated in the division.

By default, the **Division-Specific SQIs for Price Item** zone does not appear in the **Price Item** screen. It appears only when you click the **Broadcast**  icon corresponding to a division in the **Divisions** zone.

### Related Topics

For more information on...	See...
<b>Price Item</b> screen	<a href="#">Price Item (Used for Viewing)</a> on page 339

<b>For more information on...</b>	<b>See...</b>
<b>Divisions</b> zone	<a href="#">Divisions</a> on page 343

### Division-Specific Characteristics for Price Item

The **Division-Specific Characteristics for Price Item** zone lists the characteristics defined for a price item or price item bundle in a specific division. It contains the following columns:

Column Name	Column Description
Effective Date	Displays the date from when the price item or price item bundle characteristic is effective for the division.
Characteristic Type	Indicates the characteristic type.  <b>Note:</b> It has a link. On clicking the link, the <b>Characteristic Type</b> screen appears where you can view the details of the respective characteristic type.
Characteristic Value	Displays the value of the characteristic type.

By default, the **Division-Specific Characteristics for Price Item** zone does not appear in the **Price Item** screen. It appears only when you click the **Broadcast**  icon corresponding to a division in the **Divisions** zone.

### Related Topics

<b>For more information on...</b>	<b>See...</b>
<b>Price Item</b> screen	<a href="#">Price Item (Used for Viewing)</a> on page 339
<b>Divisions</b> zone	<a href="#">Divisions</a> on page 343

### Division-Specific Accrual Type Criteria for Price Item

The **Division-Specific Accrual Type Criteria for Price Item** zone lists the accrual type to which the price item or price item bundle is associated in a specific division. It contains the following column:

Field Name	Field Description	Mandatory (Yes or No)
Accrual Type Criteria	Indicates the accrual type to which you want to associate the price item or price item bundle in the division. The valid values are: <ul style="list-style-type: none"> <li>• <b>Actual</b> <ul style="list-style-type: none"> <li>- Indicates the accrual created for the price item or price item bundle is based on the current trial bill data in a division.</li> </ul> </li> <li>• <b>Historical</b> - Indicates the accrual created for the price item or price item bundle is based on the historical bill data in a division.</li> <li>• <b>Not Applicable</b> - Indicates the accrual created for the price item or price item bundle is based on the current trial bill data as well as the historical bill data in a division.</li> </ul> <p><b>Note:</b> By default, the <b>Not Applicable</b> option is selected.</p>	Yes (Conditional)  <b>Note:</b> This field is required when you are defining a division-specific accrual type criteria for the price item or price item bundle.



By default, the **Division-Specific Accrual Type Criteria for Price Item** zone does not appear in the **Price Item** screen. It appears only when you click the **Broadcast**  icon corresponding to a division in the **Divisions** zone.

### Related Topics

For more information on...	See...
<b>Price Item</b> screen	<a href="#">Price Item (Used for Viewing)</a> on page 339
<b>Divisions</b> zone	<a href="#">Divisions</a> on page 343

### Price Item Relationship

The **Price Item Relationship** zone lists the price items or price item bundles which are associated with the parent price item or added to the price item bundle. It contains the following columns:

Column Name	Column Description
Price Item Information	Displays information about the price item or price item bundle.  <b>Note:</b> It has a link. On clicking the link, the <b>Price Item</b> screen appears where you can view the details of the respective price item.
Effective Start Date	Displays the date from when the price item or price item bundle is associated with the parent price item or added to the price item bundle.
Effective End Date	Displays the date till when the price item or price item bundle is associated with the parent price item or added to the price item bundle.
Relationship Type	Indicates how the price item or price item bundle is related with the parent price item or price item bundle. The valid values are: <ul style="list-style-type: none"> <li>• Bundle</li> <li>• Custom</li> <li>• Denominator</li> <li>• Numerator</li> <li>• Other</li> <li>• Price Item</li> <li>• Service</li> <li>• Service Group</li> </ul>
Bundle Type	Indicates the type of the price item bundle. The valid values are: <ul style="list-style-type: none"> <li>• Phantom</li> <li>• Ratio</li> <li>• Regular</li> </ul> <b>Note:</b> The data appears in this column only when the associated price item is a bundle.

You can filter the list using various search criteria (such as, **Price Item**, **Description**, **Effective Start Date**, and **Relationship Type**) available in the **Filter** area. By default, the **Filter** area is hidden. You can view the **Filter** area by clicking the **Filters**  icon in the upper right corner of this zone.

You can change the layout of this zone. For more information on how to change the layout, see [Changing the Layout](#) on page 2882.

You can associate or disassociate a price item or price item bundle from a parent price item and add or remove a price item or price item bundle from a price item bundle by clicking the **Add/Edit** link in the upper right corner of this zone.

### Related Topics

For more information on...	See...
<b>Price Item</b> screen	<a href="#">Price Item (Used for Viewing)</a> on page 339
How to associate a price item or price item bundle with a parent price item	<a href="#">Associating a Price Item or Price Item Bundle with a Parent Price Item</a> on page 353
How to add a price item or price item bundle to a price item bundle	<a href="#">Adding a Price Item or Price Item Bundle to a Price Item Bundle</a> on page 356
How to disassociate a price item or price item bundle from a parent price item	<a href="#">Disassociating a Price Item or Price Item Bundle from a Parent Price Item</a> on page 361
How to remove a price item or price item bundle from a price item bundle	<a href="#">Removing a Price Item or Price Item Bundle from a Price Item Bundle</a> on page 362

### Editing a Price Item or Price Item Bundle

#### Prerequisites

To edit a price item or price item bundle, you should have:

- Contract types defined in the application
- Value defined for the **Default Contract Type** option type in the **Pricing Configuration (C1\_PRICING)** feature configuration

#### Procedure

To edit a price item or price item bundle:

1. Search for the price item or price item bundle in the **Price Item** screen.
2. In the **Search Results** section, click the link in the **Price Item Information** column corresponding to the price item or price item bundle whose details you want to edit.

The **Price Item** screen appears.

3. Click the **Edit** button in the **Price Item** zone.

The **Price Item** screen appears. It contains the following sections:

- **Main** – Used to specify basic details about the price item or price item bundle.
- **Parameters** – Used to associate a parameter with the price item or price item bundle. These associated parameters are then used for aggregating transactions and/or for defining the price item pricing.

#### **Note:**

The **Parameters** section appears in the **Price Item** screen only when the **Multi Price Parameter** option type of the **Multi Parameter Based Pricing (C1\_PPARM\_FLG)** feature configuration is set to **True**.

You cannot associate parameters to ratio and phantom price item bundles. Therefore, while editing the ratio and phantom price item bundles, the **Parameters** section does not appear in the **Price Item** screen.

- **Divisions** – Used to associate the price item or price item bundle with one or more divisions. It also allows you to define division-specific SQIs, division-specific accrual type criteria, and division-specific characteristics for the price item or price item bundle.
- **Price Item Characteristics** – Used to define characteristics (which are applicable across divisions) for the price item or price item bundle.

The **Main** section contains the following fields:

Field Name	Field Description	Mandatory (Yes or No)
Price Item	Displays the price item or price item bundle.	Not applicable
Description	Used to specify the description for the price item or price item bundle.	Yes
Price Item Usage	Used to indicate whether the price item or price item bundle is used for only pricing or pricing and billing. The valid values are: <ul style="list-style-type: none"> <li>• Pricing</li> <li>• Pricing and Billing</li> </ul> <div style="border: 1px solid black; padding: 2px; margin-top: 5px;"> <b>Note:</b> The system does not allow you to change the price item usage from <b>Pricing and Billing</b> to <b>Pricing</b> for a price item or price item bundle. </div>	Yes
Price Item Type	Used to indicate the type of price item or price item bundle. The valid values are: <ul style="list-style-type: none"> <li>• Rate</li> <li>• Fees</li> </ul> <div style="border: 1px solid black; padding: 2px; margin-top: 5px;"> <b>Note:</b> This field appears only when the <b>Price Item Usage</b> field is set to <b>Pricing</b>. </div>	Yes
Bundle	Indicates whether the price item is a bundle. The valid values are: <ul style="list-style-type: none"> <li>• Yes</li> <li>• No</li> </ul>	Not applicable

Field Name	Field Description	Mandatory (Yes or No)
Bundle Type	<p>Used to indicate the type of the price item bundle. The valid values are:</p> <ul style="list-style-type: none"> <li>• Phantom</li> <li>• Ratio</li> <li>• Regular</li> </ul> <div style="border: 1px solid black; padding: 5px; margin-top: 10px;"> <p><b>Note:</b> This field is enabled only when you select the <b>Pricing and Billing</b> option from the <b>Price Item Usage</b> list and the <b>Yes</b> option from the <b>Bundle</b> list.</p> <p>All the above mentioned values are available in the list when you are editing a price item bundle which is available for pricing and billing. However, when you are editing a price item bundle which is available for only pricing and when the price item type is set to <b>Fees</b>, you can only define a regular price item bundle. Therefore, by default, the value is set to <b>Regular</b> when the <b>Pricing</b> option is selected from the <b>Price Item Usage</b> list and the <b>Yes</b> option from the <b>Bundle</b> list.</p> </div>	<p>Yes (Conditional)</p> <div style="border: 1px solid black; padding: 5px; margin-top: 10px;"> <p><b>Note:</b> This field is required when you are editing a price item bundle.</p> </div>
Global Price List	<p>Used to indicate whether the price item or price item bundle can be assigned to a global price list. The valid values are:</p> <ul style="list-style-type: none"> <li>• Yes</li> <li>• No</li> </ul>	Yes
Contract Type	<p>Used to indicate the contract type that you want to associate with the price item or price item bundle.</p> <div style="border: 1px solid black; padding: 5px; margin-top: 10px;"> <p><b>Note:</b> This field appears only when the <b>Price Item Usage</b> field is set to <b>Pricing and Billing</b>.</p> <p>The <b>Search</b>  icon appears corresponding to the <b>Contract Type</b> field. On clicking the <b>Search</b> icon, the <b>Contract Type Search</b> window appears.</p> </div>	Yes

4. Modify the required details in the **Main** section.
5. Associate or disassociate a parameter from the price item or price item bundle, if required.

**Note:**

You can edit the parameter details and remove a parameter from the price item or price item bundle only when the parameter or any other parameter from the same date range is not yet used for aggregation or for defining the price item pricing.

You can add a parameter which will be used for aggregation (in other words, where the **Parameter Usage** field is set to **Aggregation**) anytime, whenever required. However, you can add a parameter which will be used for pricing (in other words, where the **Parameter Usage** field is set to **Pricing**) only when any other parameter from the same date range is not yet used for aggregation or for defining the price item pricing.

6. Associate or disassociate the price item or price item bundle from the divisions, if required.

**Note:** If the price item or price item bundle is associated to a division to which you do not have access, then the corresponding row in the **Divisions** section is grayed out.

7. Define, edit, or remove division-specific SQIs from the price item or price item bundle, if required.
8. Define, edit, or remove division-specific characteristics from the price item or price item bundle, if required.
9. Define, edit, or remove division-specific accrual type criteria from the price item or price item bundle, if required.
10. Define, edit, or remove characteristics from the price item or price item bundle, if required.
11. Click **Save**.

The changes made to the price item or price item bundle are saved.

**Related Topics**

<b>For more information on...</b>	<b>See...</b>
How to search for a price item or price item bundle	<a href="#">Searching for a Price Item or Price Item Bundle</a> on page 322
How to associate a price item or price item bundle with a parameter	<a href="#">Associating a Parameter with a Price Item or Price Item Bundle</a> on page 326
How to associate a price item or price item bundle with a division	<a href="#">Associating a Price Item or Price Item Bundle with a Division</a> on page 329
How to associate a price item or price item bundle with an SQI in a particular division	<a href="#">Defining Division-Specific SQIs for a Price Item or Price Item Bundle</a> on page 330
How to define a characteristic for a price item or price item bundle in a particular division	<a href="#">Defining Division-Specific Characteristics for a Price Item or Price Item Bundle</a> on page 331
How to define an accrual type criteria for a price item or price item bundle in a particular division	<a href="#">Defining Division-Specific Accrual Type Criteria for a Price Item or Price Item Bundle</a> on page 333
How to define a characteristic for a price item or price item bundle	<a href="#">Defining a Characteristic for a Price Item or Price Item Bundle</a> on page 334
How to set the <b>Pricing Configuration (C1_PRICING)</b> feature configuration	<a href="#">Setting the C1_PRICING Feature Configuration</a>

**Price Item Relationship**

Oracle Revenue Management and Billing allows you to associate two or more price items with each other, and thereby group them for various reasons, such as reporting, billing, and so on. In other words, you can define a price item to price

item relationship. The price item to which a set of price items are associated is called a parent price item. You can also create a price item bundle and then add price items to the price item bundle. The main objective behind grouping price items or creating price item bundles is to offer discounts based on the volume across price items, facilitate minimum or maximum charge calculations across price items, or offer common price across price items.

While associating a price item with a parent price item or adding a price item to a price item bundle, you need to specify how the price item is related to the parent price item or price item bundle. You can add a price item to a price item bundle using the following relationship types:

- **Bundle** – Used while adding price items in the regular and phantom price item bundles.
- **Denominator** – Used while adding price items in the ratio price item bundles.
- **Numerator** – Used while adding price items in the ratio price item bundles.

However, you can associate a price item or price item bundle with a parent price item using the following relationship types:

- Other
- Custom
- Price Item
- Service
- Service Group

**Note:**

You cannot add same set of price items using the same relationship type while defining two or more bundles with the same bundle type. For example, you cannot add P1 and P2 using the relationship type as Bundle while defining regular bundles named BUN1 and BUN2. However, you can use same set of price items while defining two or more price item to price item relationships.

If the multi parameter based pricing feature is enabled, you can add same set of price item and price item parameter combination (using the same relationship type) in more than one bundle (having the same bundle type) provided the price item parameter values are different.

The **Price Item Relationship** screen allows you to view the price items that are already associated with the parent price item or added to the price item bundle. It also allows you to associate or disassociate a price item or price item bundle from the parent price item, or add or remove a price item or price item bundle from the price item bundle. This screen consists of the following zone:

- [Assigned Price Items](#) on page 350

### Assigned Price Items

The **Assigned Price Items** zone lists the price items or price item bundles that are already associated with the parent price item or added to the price item bundle. You will not find any records in this zone if the parent price item does not have any price item or price item bundle associated with it or if the price item bundle does not have any price item or price item bundle added to it. It contains the following sections:

- **Search Criteria** – The **Search Criteria** section contains the following fields:

Field Name	Field Description	Mandatory (Yes or No)
Price Item	Used to search a particular price item or price item bundle which is associated with the parent price item or added to the price item bundle.	No
Description	Used to search price items or price item bundles with a particular description.	No

Field Name	Field Description	Mandatory (Yes or No)
Effective Start Date	Used to search price items or price item bundles which are associated with the parent price item or added to the price item bundle from a particular date.	No
Relationship Type	Used to search price items or price item bundles which are related to the parent price item or added to the price item bundle using a particular relationship type. The valid values are: <ul style="list-style-type: none"> <li>• Bundle</li> <li>• Custom</li> <li>• Denominator</li> <li>• Numerator</li> <li>• Other</li> <li>• Price Item</li> <li>• Service</li> <li>• Service Group</li> </ul>	No

- **Search Results** – On clicking the **Search** button, the search results are filtered based on the specified search criteria. The **Search Results** section contains the following columns:

Column Name	Column Description
Price Item Information	Displays information about the price item or price item bundle. <div style="border: 1px solid black; padding: 5px; margin-top: 5px;"> <p><b>Note:</b> It has a link. On clicking the link, the <b>Price Item</b> screen appears where you can view the details of the respective price item or price item bundle.</p> </div>
Effective Start Date	Displays the date from when the price item or price item bundle is associated with the parent price item or added to the price item bundle.
Effective End Date	Displays the date till when the price item or price item bundle is associated with the parent price item or added to the price item bundle.

Column Name	Column Description
Relationship Type	<p>Indicates how the price item or price item bundle is related to the parent price item or price item bundle. The valid values are:</p> <ul style="list-style-type: none"> <li>• Bundle</li> <li>• Custom</li> <li>• Denominator</li> <li>• Numerator</li> <li>• Other</li> <li>• Price Item</li> <li>• Service</li> <li>• Service Group</li> </ul> <p><b>Note:</b> The <b>Bundle</b> relationship type is used while adding price items in the regular and phantom price item bundles. The <b>Denominator</b> and <b>Numerator</b> relationship types are used while adding price items in the ratio price item bundles. And, all other relationship types, such as <b>Other</b>, <b>Custom</b>, <b>Price Item</b>, <b>Service</b>, and <b>Service Group</b> are used while associating price items to the parent price item.</p>
Price Item Parameters	Indicates the parameters based on which you want to determine pricing for the price item.

You can associate or disassociate a price item or price item bundle from a parent price item, or add or remove a price item or price item bundle from a price item bundle by clicking the **Add/Edit** link in the upper right corner of this zone.

### **Related Topics**

For more information on...	See...
<b>Price Item Relationship</b> screen	<a href="#">Price Item Relationship</a> on page 349
How to view the price items or price item bundles associated with a parent price item	<a href="#">Viewing the Price Items or Price Item Bundles Associated with a Parent Price Item</a> on page 353
How to view the price items or price item bundles added to a price item bundle	<a href="#">Viewing the Price Items or Price Item Bundles Added to a Price Item Bundle</a> on page 353
How to associate a price item or price item bundle with a parent price item	<a href="#">Associating a Price Item or Price Item Bundle with a Parent Price Item</a> on page 353
How to add a price item or price item bundle to a price item bundle	<a href="#">Adding a Price Item or Price Item Bundle to a Price Item Bundle</a> on page 356
How to disassociate a price item or price item bundle from a parent price item	<a href="#">Disassociating a Price Item or Price Item Bundle from a Parent Price Item</a> on page 361
How to remove a price item or price item bundle from a price item bundle	<a href="#">Removing a Price Item or Price Item Bundle from a Price Item Bundle</a> on page 362
How to filter the price items or price item bundles associated with a parent price item	<a href="#">Filtering the Price Items or Price Item Bundles Associated with a Parent Price Item</a> on page 362
How to filter the price items or price item bundles added to a price item bundle	<a href="#">Filtering the Price Items or Price Item Bundles Added to a Price Item Bundle</a> on page 363



## Viewing the Price Items or Price Item Bundles Associated with a Parent Price Item

### Procedure

To view the price items or price item bundles associated with a parent price item:

1. Search for the price item in the **Price Item** screen.
2. In the **Search Results** section, click the **Price Item Relationship** (☰) icon in the **Price Item Relationship** column corresponding to the price item whose relationship details you want to view.

The **Price Item Relationship** screen appears.

3. View the price items or price item bundles that are associated with the parent price item in the **Assigned Price Items** zone.

### Related Topics

For more information on...	See...
How to search for a price item	<a href="#">Searching for a Price Item or Price Item Bundle</a> on page 322
<b>Price Item Relationship</b> screen	<a href="#">Price Item Relationship</a> on page 349
<b>Assigned Price Items</b> zone	<a href="#">Assigned Price Items</a> on page 350

## Viewing the Price Items or Price Item Bundles Added to a Price Item Bundle

### Procedure

To view the price items or price item bundles added to a price item bundle:

1. Search for the price item bundle in the **Price Item** screen.
2. In the **Search Results** section, click the **Price Item Relationship** (☰) icon in the **Price Item Relationship** column corresponding to the price item bundle whose relationship details you want to view.

The **Price Item Relationship** screen appears.

3. View the price items or price item bundles that are added to the price item bundle in the **Assigned Price Items** zone.

### Related Topics

For more information on...	See...
How to search for a price item bundle	<a href="#">Searching for a Price Item or Price Item Bundle</a> on page 322
<b>Price Item Relationship</b> screen	<a href="#">Price Item Relationship</a> on page 349
<b>Assigned Price Items</b> zone	<a href="#">Assigned Price Items</a> on page 350

## Associating a Price Item or Price Item Bundle with a Parent Price Item

### Prerequisites

To associate a price item or price item bundle with a parent price item, you should have:

- Parent price item associated with the division to which the user belongs
- Price item or price item bundle associated to at least one division to which the parent price item belongs.

### Procedure

To associate a price item or price item bundle with a parent price item:



1. Search for the parent price item in the **Price Item** screen.
2. In the **Search Results** section, click the **Price Item Relationship** (🔍) icon in the **Price Item Relationship** column corresponding to the parent price item to which you want to associate a price item or price item bundle.

The **Price Item Relationship** screen appears.

3. Click the **Add/Edit** link in the upper right corner of the **Assigned Price Items** zone.

The **Price Item Relationship** screen appears. It contains the following fields in a grid:

Field Name	Field Description	Mandatory (Yes or No)
Price Item	Used to indicate the price item or price item bundle that you want to associate with the parent price item.  <b>Note:</b> The <b>Search</b> (🔍) icon appears corresponding to this field. On clicking the <b>Search</b> icon, the <b>Price Item Search</b> window appears.	Yes
Relationship Type	Used to indicate how the price item or price item bundle is related with the parent price item. The valid values are: <ul style="list-style-type: none"> <li>• Bundle</li> <li>• Custom</li> <li>• Denominator</li> <li>• Numerator</li> <li>• Other</li> <li>• Price Item</li> <li>• Service</li> <li>• Service Group</li> </ul> <b>Note:</b> You can use the <b>Other, Custom, Price Item, Service, or Service Group</b> relationship type while associating a price item or price item bundle to the parent price item.	Yes
Effective Start Date	Used to specify the date from when you want to associate the price item or price item bundle with the parent price item.  <b>Note:</b> The effective start date cannot be later than the effective end date.	Yes
Effective End Date	Used to specify the date till when you want to associate the price item or price item bundle with the parent price item.  <b>Note:</b> The effective end date cannot be earlier than the effective start date.	No

Field Name	Field Description	Mandatory (Yes or No)
Price Item Parameters	<p>Used to specify the parameters and their values based on which you want to determine pricing for the price item or price item bundle.</p> <p><b>Note:</b></p> <p>This field appears only when the <b>Multi Price Parameter</b> option type of the <b>Multi Parameter Based Pricing (C1_PPARM_FLG)</b> feature configuration is set to <b>True</b>.</p> <p>The <b>Search</b> () icon appears corresponding to this field. On clicking the <b>Search</b> icon, the <b>Price Item Parameters</b> screen appears.</p> <p>You must not use the <b>Price Item Parameters</b> field while associating a price item or price item bundle with a parent price item. This is because it is designed to be used while adding a price item or price item bundle to the ratio and phantom price item bundles.</p>	Not applicable
Characteristics	<p>On clicking the <b>Add</b> () icon, you can define relationship-specific characteristics for the price item or price item bundle.</p>	Not applicable

4. Enter the required details in the **Price Item Relationship** screen.

**Note:** You can associate the same set of price items or price item bundles using the same relationship type to more than one parent price item. For example, you can associate the **P1** and **P2** price items using the **Service** relationship type to the **PP1** and **PP2** price items.

5. Define relationship-specific characteristics for the price item or price item bundle, if required.
6. If you want to associate more than one price item or price item bundle with the parent price item, click the **Add** () icon and then repeat the steps from 4 to 5.

**Note:** However, if you want to disassociate a price item or price item bundle from a parent price item, click the **Delete** () icon corresponding to the price item or price item bundle.

7. Click **Save**.

The price item or price item bundle is associated with the parent price item.

### **Related Topics**

For more information on...	See...
How to search for a parent price item	<a href="#">Searching for a Price Item or Price Item Bundle</a> on page 322
<b>Price Item Relationship</b> screen	<a href="#">Price Item Relationship</a> on page 349
<b>Assigned Price Items</b> zone	<a href="#">Assigned Price Items</a> on page 350
How to define relationship-specific characteristics for a price item or price item bundle	<a href="#">Defining Relationship-Specific Characteristics for a Price Item or Price Item Bundle</a> on page 360

## Adding a Price Item or Price Item Bundle to a Price Item Bundle

### Prerequisites

To add a price item or price item bundle to a price item bundle, you should have:

- Price item bundle (to which you want to add a price item or price item bundle) associated with the division to which the user belongs
- Price item bundle (to which you want to add a price item or price item bundle) and price item or price item bundle (which you want to add) associated to the same contract type
- Parameters associated with the price item or price item bundle (which you want to add) when you want to determine pricing for the price item based on the parameters in the ratio and phantom price item bundles
- Regular price item bundle (to which you want to add a price item or price item bundle) and price item or price item bundle (which you want to add) associated with the same parameters

**Note:** Not only the parameters, but also their details such as parameter usage, mandatory flag, and priority should be identical. Also, the date from when the parameters are effective for the price item bundle (to which you want to add a price item or price item bundle) should be earlier than or equal to the date from when the parameters are effective for the price item or price item bundle (which you want to add).

- Price item or price item bundle (which you want to add) associated to at least one division to which the price item bundle (to which you want to add a price item or price item bundle) belongs

### Procedure

To add a price item or price item bundle to a price item bundle:



1. Search for the price item bundle in the **Price Item** screen.
2. In the **Search Results** section, click the **View** (🔍) icon in the **Price Item Relationship** column corresponding to the price item bundle to which you want to add a price item or price item bundle.

The **Price Item Relationship** screen appears.

3. Click the **Add/Edit** link in the upper right corner of the **Assigned Price Items** zone.

The **Price Item Relationship** screen appears. It contains the following fields in a grid:

Field Name	Field Description	Mandatory (Yes or No)
Price Item	Used to indicate the price item or price item bundle that you want to add to the price item bundle.  <b>Note:</b> The <b>Search</b> (🔍) icon appears corresponding to the <b>Price Item</b> field. On clicking the <b>Search</b> icon, the <b>Price Item Search</b> window appears.	Yes

Field Name	Field Description	Mandatory (Yes or No)
Relationship Type	<p>Used to indicate how the price item or price item bundle is related to the price item bundle. The valid values are:</p> <ul style="list-style-type: none"> <li>• Bundle</li> <li>• Custom</li> <li>• Denominator</li> <li>• Numerator</li> <li>• Other</li> <li>• Price Item</li> <li>• Service</li> <li>• Service Group</li> </ul> <p><b>Note:</b> You can use the <b>Bundle</b> relationship type while adding a price item or price item bundle in the regular and phantom price item bundles. However, you can use the <b>Denominator</b> and <b>Numerator</b> relationship type while adding a price item or price item bundle in the ratio price item bundles.</p>	Yes
Effective Start Date	<p>Used to specify the date from when the price item or price item bundle is added to the price item bundle.</p> <p><b>Note:</b> The effective start date cannot be later than the effective end date.</p>	Yes
Effective End Date	<p>Used to specify the date till when the price item or price item bundle is added to the price item bundle.</p> <p><b>Note:</b> The effective end date cannot be earlier than the effective start date.</p>	No
Price Item Parameters	<p>Used to specify the parameters and their values based on which you want to determine pricing for the price item or price item bundle.</p> <p><b>Note:</b> This field appears only when the <b>Multi Price Parameter</b> option type of the <b>Multi Parameter Based Pricing (C1_PPARM_FLG)</b> feature configuration is set to <b>True</b>. The <b>Search</b>  icon appears corresponding to the <b>Price Item Parameters</b> field. On clicking the <b>Search</b> icon, the <b>Price Item Parameters</b> screen appears.</p>	No
Characteristics	<p>On clicking the <b>Add</b>  icon, you can define relationship-specific characteristics for the price item or price item bundle.</p>	Not applicable

4. Enter the required details in the **Price Item Relationship** screen.

**Note:**

You can add a price item or price item bundle to a regular price item bundle only when the regular price item bundle (to which you want to add a price item or price item bundle) and price item or price item bundle (which you want to add) are associated with the same parameters for the specified date range.

You cannot add the same set of price items using the same relationship type to two or more price item bundles with the same bundle type. For example, you cannot add **P1** and **P2** using the **Bundle** relationship type to the **BUN1** and **BUN2** regular price item bundles.

If the multi parameter based pricing feature is enabled, you can add the same set of price item and price item parameter combination (using the same relationship type) to more than one bundle (with the same bundle type) provided the price item parameter values are different.

You cannot add the same price item or price item bundle in numerator and denominator while defining a ratio price item bundle.

5. Define relationship-specific characteristics for the price item or price item bundle, if required.
6. If you want to add more than one price item or price item bundle to the price item bundle, click the **Add** () icon and then repeat the steps from 4 to 5.

**Note:** However, if you want to remove a price item or price item bundle from a price item bundle, click the **Delete** () icon corresponding to the price item or price item bundle.

7. Click **Save**.

The price item or price item bundle is added to the price item bundle.

**Related Topics**

For more information on...	See...
How to search for a price item bundle	<a href="#">Searching for a Price Item or Price Item Bundle</a> on page 322
<b>Price Item Relationship</b> screen	<a href="#">Price Item Relationship</a> on page 349
<b>Assigned Price Items</b> zone	<a href="#">Assigned Price Items</a> on page 350
How to set the parameters for a price item or price item bundle	<a href="#">Setting the Parameters for a Price Item or Price Item Bundle</a> on page 358
How to define relationship-specific characteristics for a price item or price item bundle	<a href="#">Defining Relationship-Specific Characteristics for a Price Item or Price Item Bundle</a> on page 360

**Setting the Parameters for a Price Item or Price Item Bundle****Prerequisites**

To set the parameters for a price item or price item bundle, you should have:

- Parameters (where the **Parameter Usage** field is set to **Pricing**) associated with the price item or price item bundle

**Procedure**

To set the parameters for a price item or price item bundle:

1. Click the **Search** () icon corresponding to the **Price Item Parameters** field.

The **Price Item Parameters** screen appears. It contains the following fields:

Field Name	Field Description
Price Item	Indicates the price item or price item bundle for which you want to set the parameters.
Description	Displays the description of the price item or price item bundle.

In addition, this screen contains the following fields in a grid:

Field Name	Field Description	Mandatory (Yes or No)
Price Item Parameter	Indicates the parameter which is associated with the price item or price item bundle.  <b>Note:</b> Here, the system displays the price item parameter where the <b>Parameter Usage</b> field is set to <b>Pricing</b> .	Not applicable
Mandatory	Indicates whether the parameter is mandatory while defining the price item pricing. The valid values are: <ul style="list-style-type: none"> <li>• Yes</li> <li>• No</li> </ul>	Not applicable
Priority	Indicates the priority in which optional parameters should be considered while determining best fit price for the price item or price item bundle.  <b>Note:</b> The priority for all parameters which are mandatory is set to 0.	Not applicable
Parameter Value	Used to specify the parameter value.  <b>Note:</b> If the parameter value type is <b>Predefined</b> or <b>Reference</b> , the <b>Search</b>  icon appears corresponding to the <b>Parameter Value</b> field. On clicking the <b>Search</b> icon, you can search for a parameter value.  You can specify any special characters except ampersand (&), comma (,), underscore (_), equal to (=), tilde (~), and semi-colon(;) in the parameter value.	Yes (Conditional)  <b>Note:</b> This field is required when you want to determine pricing for the price item or price item bundle based on the parameter.

2. Enter the required details in the **Price Item Parameters** screen.
3. Click **OK**.

A comma-separated list of values appear in the **Price Item Parameters** column corresponding to the price item or price item bundle. The order in which parameter values appear in the price item parameter information string is controlled by the display order (which is defined while associating a parameter with a price item).

**Note:** The value specified for a parameter whose value type is set to **Adhoc** is validated using the validation algorithm attached to the respective parameter.

### Related Topics

For more information on...	See...
How to add a price item or price item bundle to a price item bundle	<a href="#">Adding a Price Item or Price Item Bundle to a Price Item Bundle</a> on page 356

## Defining Relationship-Specific Characteristics for a Price Item or Price Item Bundle

### Prerequisites

To define relationship-specific characteristics for a price item or price item bundle, you should have:

- Characteristic types defined in the application (where the characteristic entity is set to **Price Item Relationship**)

### Procedure

To define relationship-specific characteristics for a price item or price item bundle:

1. Click the **Add** (  ) icon in the **Characteristics** column corresponding to the price item or price item bundle for which you want to define relationship-specific characteristics.

A grid appears corresponding to the price item or price item bundle with the following fields:

Field Name	Field Description	Mandatory (Yes or No)
Effective Date	Used to specify the date from when the relationship-specific characteristic is effective for the price item or price item bundle.	Yes (Conditional) <b>Note:</b> This field is required when you are defining a relationship-specific characteristic for the price item or price item bundle.
Characteristic Type	Used to indicate the characteristic type. <b>Note:</b> The list includes only those characteristic types where the characteristic entity is set to <b>Price Item Relationship</b> .	Yes (Conditional) <b>Note:</b> This field is required when you are defining a relationship-specific characteristic for the price item or price item bundle.
Characteristic Value	Used to specify the value for the characteristic type. <b>Note:</b> If you select a predefined characteristic type, the <b>Search</b> (  ) icon appears corresponding to the <b>Characteristic Value</b> field. On clicking the <b>Search</b> icon, the <b>Predefined Characteristic Search</b> window appears. On specifying the value for a predefined characteristic type, the description of the characteristic value appears corresponding to the <b>Characteristic Value</b> field.	Yes (Conditional) <b>Note:</b> This field is required when you are defining a relationship-specific characteristic for the price item or price item bundle.

2. Enter the required details in the **Characteristics** grid.
3. If you want to define more than one relationship-specific characteristic for the price item or price item bundle, click the **Add** (  ) icon and then repeat step 2.



**Note:** However, if you want to remove a relationship-specific characteristic from the price item or price item bundle, click the **Delete** () icon corresponding to the characteristic.

4. Click **Save**.

The relationship-specific characteristics are defined for the price item or price item bundle.

### **Related Topics**

<b>For more information on...</b>	<b>See...</b>
How to associate a price item or price item bundle with a parent price item	<a href="#">Associating a Price Item or Price Item Bundle with a Parent Price Item</a> on page 353
How to add a price item or price item bundle to a price item bundle	<a href="#">Adding a Price Item or Price Item Bundle to a Price Item Bundle</a> on page 356

### **Disassociating a Price Item or Price Item Bundle from a Parent Price Item**

#### **Prerequisites**

To disassociate a price item or price item bundle from a parent price item, you should have:

- Parent price item associated with the division to which the user belongs

#### **Procedure**

To disassociate a price item or price item bundle from a parent price item:

1. Search for the parent price item in the **Price Item** screen.
2. In the **Search Results** section, click the **View** () icon in the **Price Item Relationship** column corresponding to the parent price item from which you want to disassociate a price item or price item bundle.

The **Price Item Relationship** screen appears.

3. Click the **Add/Edit** link in the upper right corner of the **Assigned Price Items** zone.

The **Price Item Relationship** screen appears.

4. Filter the price items or price item bundles associated to the parent price item, if required.
5. In the **Search Results** section, click the **Delete** () icon corresponding to the price item or price item bundle that you want to disassociate from the parent price item.

6. Click **Save**.

The price item or price item bundle is disassociated from the parent price item.

### **Related Topics**

<b>For more information on...</b>	<b>See...</b>
How to search for a parent price item	<a href="#">Searching for a Price Item or Price Item Bundle</a> on page 322
<b>Price Item Relationship</b> screen	<a href="#">Price Item Relationship</a> on page 349
<b>Assigned Price Items</b> zone	<a href="#">Assigned Price Items</a> on page 350
How to filter the price items or price item bundles associated with the parent price item	<a href="#">Filtering the Price Items or Price Item Bundles Associated with a Parent Price Item</a> on page 362

## Removing a Price Item or Price Item Bundle from a Price Item Bundle

### Prerequisites

To remove a price item or price item bundle from a price item bundle, you should have:

- Price item bundle associated with the division to which the user belongs

### Procedure

To remove a price item or price item bundle from a price item bundle:

1. Search for the price item bundle in the **Price Item** screen.
2. In the **Search Results** section, click the **View** (🔍) icon in the **Price Item Relationship** column corresponding to the price item bundle from which you want to remove a price item or price item bundle.  
The **Price Item Relationship** screen appears.
3. Click the **Add/Edit** link in the upper right corner of the **Assigned Price Items** zone.  
The **Price Item Relationship** screen appears.
4. Filter the price items or price item bundles added to the price item bundle, if required.
5. In the **Search Results** section, click the **Delete** (🗑) icon corresponding to the price item or price item bundle that you want to remove from the price item bundle.
6. Click **Save**.  
The price item or price item bundle is removed from the price item bundle.

### Related Topics

For more information on...	See...
How to search for a price item bundle	<a href="#">Searching for a Price Item or Price Item Bundle</a> on page 322
<b>Price Item Relationship</b> screen	<a href="#">Price Item Relationship</a> on page 349
<b>Assigned Price Items</b> zone	<a href="#">Assigned Price Items</a> on page 350
How to filter the price items or price item bundles added to the price item bundle	<a href="#">Filtering the Price Items or Price Item Bundles Added to a Price Item Bundle</a> on page 363

## Filtering the Price Items or Price Item Bundles Associated with a Parent Price Item

### Prerequisites

To filter the price items or price item bundles associated with a parent price item, you should have:

- Parent price item associated with the division to which the user belongs

### Procedure

To filter the price items or price item bundles associated with a parent price item:

1. Search for the parent price item in the **Price Item** screen.
2. In the **Search Results** section, click the **View** (🔍) icon in the **Price Item Relationship** column corresponding to the parent price item whose details you want to view.  
The **Price Item Relationship** screen appears.
3. Enter the search criteria in the **Assigned Price Items** zone.

**Note:** ORMB search engine supports wildcard search, where you can substitute the percentage (%) symbol as a stand in for any word or letter in a search criteria. You can use the ‘%’ wildcard character in all input fields except the date and ID fields. The ‘%’ wildcard character is suffixed automatically at the end of the partial search criteria. Therefore, you may or may not specify the wildcard character at the end of the partial search criteria. However, you have to prefix the wildcard character manually wherever required.

#### 4. Click **Search**.

The search results are filtered based on the specified criteria.

#### Related Topics

For more information on...	See...
How to search for a parent price item	<a href="#">Searching for a Price Item or Price Item Bundle</a> on page 322
<b>Price Item Relationship</b> screen	<a href="#">Price Item Relationship</a> on page 349
<b>Assigned Price Items</b> zone	<a href="#">Assigned Price Items</a> on page 350

### Filtering the Price Items or Price Item Bundles Added to a Price Item Bundle

#### Prerequisites

To filter the price items or price item bundles added to a price item bundle, you should have:

- Price item bundle associated with the division to which the user belongs

#### Procedure

To filter the price items or price item bundles added to a price item bundle:

1. Search for the price item bundle in the **Price Item** screen.
2. In the **Search Results** section, click the **View** (🔍) icon in the **Price Item Relationship** column corresponding to the price item bundle whose details you want to view.

The **Price Item Relationship** screen appears.

3. Enter the search criteria in the **Assigned Price Items** zone.

**Note:** ORMB search engine supports wildcard search, where you can substitute the percentage (%) symbol as a stand in for any word or letter in a search criteria. You can use the ‘%’ wildcard character in all input fields except the date and ID fields. The ‘%’ wildcard character is suffixed automatically at the end of the partial search criteria. Therefore, you may or may not specify the wildcard character at the end of the partial search criteria. However, you have to prefix the wildcard character manually wherever required.

#### 4. Click **Search**.

The search results are filtered based on the specified criteria.

#### Related Topics

For more information on...	See...
How to search for a price item bundle	<a href="#">Searching for a Price Item or Price Item Bundle</a> on page 322
<b>Price Item Relationship</b> screen	<a href="#">Price Item Relationship</a> on page 349
<b>Assigned Price Items</b> zone	<a href="#">Assigned Price Items</a> on page 350

## Price Item Assignments

The **Price Item Assignments** screen allows you to view the active price lists, persons, and accounts where the price item or price item bundle is assigned. It contains the following zones:

- [Active Price Lists where Price Item is Assigned](#) on page 364
- [Persons to whom Price Item is Assigned](#) on page 364
- [Accounts where Price Item is Assigned](#) on page 365

### Active Price Lists where Price Item is Assigned

The **Active Price Lists where Price Item is Assigned** zone lists the active price lists where the pricing is defined for the price item or price item bundle. It contains the following columns:

Column Name	Column Description
Price List Information	Displays information about the price list.  <b>Note:</b> It has a link. On clicking the link, the <b>Price List</b> screen appears where you can view the details of the respective price list.
Effective Start Date	Displays the date from when the price list is effective.
Effective End Date	Displays the date till when the price list is effective.
Availability Start Date	Displays the date from when the price list is available for assignment.
Availability End Date	Displays the date till when the price list is available for assignment.

### Related Topics

For more information on...	See...
<b>Price Item Assignments</b> screen	<a href="#">Price Item Assignments</a> on page 364
How to view the price lists, persons, or accounts where a price item is assigned	<a href="#">Viewing the Price Lists, Persons, or Accounts where a Price Item is Assigned</a> on page 365

### Persons to whom Price Item is Assigned

The **Persons to whom Price Item is Assigned** zone lists the persons where the pricing is defined for the price item or price item bundle. It contains the following columns:

Column Name	Column Description
Person ID	Indicates the person to whom the price item is assigned.
Person Information	Displays information about the person. In addition, this column has a context menu which helps in navigating to other screens in the application.  <b>Note:</b> It has a link. On clicking the link, the <b>Person</b> screen appears where you can view the details of the respective person.
Price Assignment Start Date	Displays the date from when the price item is assigned to the person.
Price Assignment End Date	Displays the date till when the price item is assigned to the person.
Division	Indicates the division to which the person belongs.

Column Name	Column Description
Price Assignment ID	Indicates the price item pricing which is assigned to the person.

### **Related Topics**

For more information on...	See...
<b>Price Item Assignments</b> screen	<a href="#">Price Item Assignments</a> on page 364
How to view the price lists, persons, or accounts where a price item is assigned	<a href="#">Viewing the Price Lists, Persons, or Accounts where a Price Item is Assigned</a> on page 365

### **Accounts where Price Item is Assigned**

The **Accounts where Price Item is Assigned** zone lists the accounts where the pricing is defined for the price item or price item bundle. It contains the following columns:

Column Name	Column Description
Account ID	Indicates the account where the price item is assigned.
Account Information	Displays information about the account. In addition, this column has a context menu which helps in navigating to other screens in the application.  <b>Note:</b> It has a link. On clicking the link, the <b>Account</b> screen appears where you can view the details of the respective account.
Price Assignment Start Date	Displays the date from when the price item is assigned to the account.
Price Assignment End Date	Displays the date till when the price item is assigned to the account.
Division	Indicates the division to which the account belongs.
Price Assignment ID	Indicates the price item pricing which is assigned to the account.

### **Related Topics**

For more information on...	See...
<b>Price Item Assignments</b> screen	<a href="#">Price Item Assignments</a> on page 364
How to view the price lists, persons, or accounts where a price item is assigned	<a href="#">Viewing the Price Lists, Persons, or Accounts where a Price Item is Assigned</a> on page 365

### **Viewing the Price Lists, Persons, or Accounts where a Price Item is Assigned**

#### **Prerequisites**

To view the price lists, persons, or accounts where the price item or price item bundle is assigned, you should have:

- Price item or price item bundle assigned to a price list, person, or account

#### **Procedure**

To view the price lists, persons, or accounts where the price item or price item bundle is assigned:

1. Search for the price item or price item bundle in the **Price Item** screen.
2. In the **Search Results** section, click the **View**  icon in the **Price Item Assigned To** column corresponding to the price item or price item bundle whose assignment details you want to view.

The **Price Item Assignments** screen appears.

3. View the price lists where the pricing is defined for the price item or price item bundle in the **Active Price Lists where Price Item is Assigned** zone.
4. View the accounts where the pricing is defined for the price item or price item bundle in the **Accounts where Price Item is Assigned** zone.
5. View the persons where the pricing is defined for the price item or price item bundle in the **Person to whom Price Item is Assigned** zone.

### Related Topics

For more information on...	See...
How to search for a price item or price item bundle	<a href="#">Searching for a Price Item or Price Item Bundle</a> on page 322
<b>Price Item Assignments</b> screen	<a href="#">Price Item Assignments</a> on page 364
<b>Active Price Lists where Price Item is Assigned</b> zone	<a href="#">Active Price Lists where Price Item is Assigned</a> on page 364
<b>Accounts where Price Item is Assigned</b> zone	<a href="#">Accounts where Price Item is Assigned</a> on page 365
<b>Person to whom Price Item is Assigned</b> zone	<a href="#">Persons to whom Price Item is Assigned</a> on page 364

## Price List

---

A price list allows you to define standard prices for a group of price items. In other words, a price list is a rate card for price items or services which are offered to the accounts or persons. You can create more than one price list. For example, you can create a price list for large, medium-sized, and small customers. You can also create a set of price lists for different regions. You can define two types of price lists — **Standard** and **Promotional**. You can also set eligibility criteria for the price list with effective start date, end date, and description. At present, there is no functionality associated with the price list type. The implementation team can use the price list type to define the custom logic as per the business requirements.

A price list and price item pricing within the price list are effective for a particular duration. You can define multiple pricing for the same price item and variance parameter or product parameters combination within a price list only when the price item pricing date range is different. You can assign the same price item in multiple price lists and define different pricing for the price item in each price list based on the business requirements.

The system enables you to specify the duration for which the price list is available for assignment to an account or a person. However, note that at present, the availability start and end dates are not used in the product while assigning a price list to an account or a person. If required, the implementation team can build the custom logic using the availability start and end dates in the product.

Once you create a price list, you have to assign price items to the price list and define pricing for each price item assigned to the price list. The price lists are then assigned to accounts or persons to indicate the prices that will be charged for various price items or services offered to them. You can assign multiple price lists to an account or a person for an overlapping date range. But, you need to specify the priority or order for the price list in which the pricing from the price list should be considered. You can also assign the same price list to multiple accounts or persons.

You can define whether the account or person can avail the price item pricing listed on the parent or grandparent price list if it is not available on the assigned price list. In other words, you can define whether the account or person can inherit price item pricing from the price list hierarchy.

The system allows you to create the following:

- **Default Price List** – You can create a price list and set it as a default price list for a particular division. To define a default price list for a division, you need to set the value for the **Default Price List ID** parameter in the price

assignment search algorithm which is attached to the division. If the effective price item pricing is not available at any level in the customer hierarchy, the system checks whether the default price list is specified in the price assignment search algorithm. If the default price list is specified in the algorithm, the system checks whether effective price item pricing is available in the default price list and accordingly uses the price item pricing. You can have the same price list as a the default price list for multiple divisions.

- **Global Price List** – You can create one global price list in the system. It is used only when the price item pricing is not available at any level in the customer hierarchy and in the default price list associated with the division. You can assign only those price items in the global price list whose the **Global Price List** option is set to **Yes**. The global price list is used while searching an effective price item pricing only when the **Global Price List** parameter in the price assignment search algorithm (attached to the division) is set to **Y**. Finally, if the effective price item pricing is not available in the default and/or global price list, an error message occurs indicating that the effective price item pricing is not available in the system.
- **Template Price List** – You can define a template price list and assign template price item pricing to a template price list. You cannot assign template price list to an account or a person. You can only create a copy of a template price item pricing which is assigned to a template price list. Once you create a copy of the template price item pricing, you can save the new price item pricing in either **Active** or **Proposed** status.

## Price List (Used for Searching)

The **Price List** screen allows you to search for a price list using various search criteria. It also allows you to create a price list. This screen consists of the following zones:

- [Search Price List](#) on page 367
- [Price List Price Items](#) on page 370

### Search Price List

The **Search Price List** zone allows you to search for a price list using various search criteria. It contains the following two sections:

- **Search Criteria** - The **Search Criteria** section contains the following fields:

Field Name	Field Description	Mandatory (Yes or No)
Search By	Used to indicate whether you want to search for a price list using the price list details. The valid value is: <ul style="list-style-type: none"> <li>• Price List Details</li> </ul> <div style="border: 1px solid black; padding: 2px; margin-top: 5px;"><b>Note:</b> By default, the <b>Price List Details</b> option is selected.</div>	Yes
Price List ID	Used to search a particular price list.	No
Price List Description	Used to search a price list with a particular description.	No
Effective Start Date	Used to search price lists which are effective from a particular date.	No
Effective End Date	Used to search price lists which are effective till a particular date.	No



Field Name	Field Description	Mandatory (Yes or No)
Price List Type	<p>Used to search a particular type of price lists. The valid values are:</p> <ul style="list-style-type: none"> <li>• Promotional</li> <li>• Standard</li> </ul> <p><b>Note:</b> By default, the <b>Standard</b> option is selected.</p>	No
Global Price List	<p>Used to indicate whether you want to search a global price list. The valid values are:</p> <ul style="list-style-type: none"> <li>• Yes</li> <li>• No</li> </ul>	No
Availability Start Date	<p>Used to search price lists which are available for assignment to an account or a person from a particular date.</p> <p><b>Note:</b> By default this field does not appear. This field appears only when you click the <b>Advanced Search</b> link in the upper right corner of the <b>Search Price List</b> zone.</p>	No
Availability End Date	<p>Used to search price lists which are available for assignment to an account or a person till a particular date.</p> <p><b>Note:</b> By default this field does not appear. This field appears only when you click the <b>Advanced Search</b> link in the upper right corner of the <b>Search Price List</b> zone.</p>	No
Status	<p>Used to search price lists with a particular status. The valid values are:</p> <ul style="list-style-type: none"> <li>• Active</li> <li>• Proposed</li> <li>• Template</li> </ul> <p><b>Note:</b> By default this field does not appear. This field appears only when you click the <b>Advanced Search</b> link in the upper right corner of the <b>Search Price List</b> zone.</p>	No
Division	<p>Used to search price lists which are associated with a particular division.</p> <p><b>Note:</b> You can only view those divisions to which you have access in the <b>Division</b> list.</p>	No



Field Name	Field Description	Mandatory (Yes or No)
Parent Price List	Used to search price lists which inherit pricing from a particular parent price list.  <b>Note:</b> The <b>Search</b>  icon appears corresponding to this field. On clicking the <b>Search</b> icon, the <b>Price List Search</b> window appears.  By default this field does not appear. This field appears only when you click the <b>Advanced Search</b> link in the upper right corner of the <b>Search Price List</b> zone.	No
Parent Price List Effective Date	Used to search price lists that can inherit pricing from a parent price list which is effective from a particular date.  <b>Note:</b> By default this field does not appear. This field appears only when you click the <b>Advanced Search</b> link in the upper right corner of the <b>Search Price List</b> zone.	No

**Note:** You must specify at least one search criterion while searching for a price list.

- **Search Results** – On clicking the **Search** button, the search results appear based on the specified search criteria. The **Search Results** section contains the following columns:

Column Name	Column Description
Price List Information	Displays information about the price list.  <b>Note:</b> It has a link. On clicking the link, the <b>Price List</b> screen appears where you can view the details of the respective price list.
Status	Indicates the status of the price list. The valid values are: <ul style="list-style-type: none"> <li>• Active</li> <li>• Proposed</li> <li>• Template</li> </ul>
Effective Start Date	Displays the date from when the price list is effective.
Effective End Date	Displays the date till when the price list is effective.
Availability Start Date	Displays the date from when the price list is available for assignment to an account or a person.
Availability End Date	Displays the date till when the price list is available for assignment to an account or a person.
Copy	On clicking the <b>Copy</b>  icon, the <b>Price List</b> screen appears where you can create a new price list using an existing price list.
Price List Pricing	On clicking the <b>View</b>  icon in the <b>Price List Pricing</b> column, the <b>Price List Price Item Pricing</b> screen appears where you can view and edit a list of price items pricing information assigned to the price list.

Column Name	Column Description
Price List Assigned To	On clicking the <b>View</b> (🔍) icon in the <b>Price List Assigned To</b> column, the <b>Price List Assignments</b> screen appears where you can view the details of the persons and accounts to which the price list is assigned.
Eligible Accounts/ Persons	On clicking the <b>View</b> (🔍) icon in the <b>Eligible Accounts/Persons</b> column, the <b>Entities Eligible for Price List Assignment</b> screen appears where you can search for a list of eligible accounts and persons to which you want to assign the price list in a particular division.

**Note:**

However, when you search for a price list by specifying the date (which can be current, past or future date) in the **Parent Price List Effective Date** field, the system retrieves the price lists that meet the search criteria along with the details of the parent price list that is effective on that date.

Pagination is used to display limited number of records in the **Search Results** section. You can use the navigation links, such as **Previous** and **Next** to navigate between pages.

By default, the **Filter** area is visible. You can hide the **Filter** area by clicking the **Filters** (🗑️) icon in the upper right corner of this zone.

On clicking the **Broadcast** (📡) icon corresponding to the **Price List Information** field, the **Price List Price Items** zone appears where you can view a list of price items to which the price list is assigned.

**Related Topics**

For more information on...	See...
<b>Price List Price Items</b> zone	<a href="#">Price List Price Items</a> on page 388
How to search for a price list	<a href="#">Searching for a Price List</a> on page 371
How to view price items assigned to a price list	<a href="#">Viewing Price Items Assigned to a Price List</a> on page 372
How to view the details of a price list	<a href="#">Viewing the Price List Details</a> on page 381
How to copy a price list	<a href="#">Copying a Price List</a> on page 380
How to view price list price items and assign price items	<a href="#">Price List Price Item Pricing</a> on page 387
How to view the details of the price list assigned	<a href="#">Price List Assignments</a> on page 431
How to search for eligible accounts and persons to be assigned to the price list.	<a href="#">Persons and Accounts Eligible for Price List Assignment</a> on page 433

**Price List Price Items**

The **Price List Price Items** zone lists price items that are assigned to the price list. You will not find any records in this zone if the price list does not have any price items assigned to it. It contains the following columns:

Column Name	Column Description
Pricing	Displays the concatenated string consisting of pricing information and pricing ID which are separated by a comma (,) for the price list.  <b>Note:</b> It has a link. On clicking the link, the <b>Price Item Pricing</b> screen appears where you can view the pricing information of the respective price list.

Column Name	Column Description
Pricing Parameters	Used to specify multiple parameters based on which you want to determine the pricing utilization.  <b>Note:</b> This column appears only when the <b>Multi Price Parameter</b> option type of the <b>Multi Parameter Based Pricing (C1_PPARAM_FLG)</b> feature configuration is set to <b>True</b> .
Pricing Status	Displays the status of pricing for the price item. The valid values are: <ul style="list-style-type: none"> <li>• Active</li> <li>• Inactive</li> </ul>
Effective Start Date	Displays the date from when the price item pricing is effective for the price list.
Effective End Date	Displays the date till when the price item pricing is effective for the price list.
Price Assignment Type	Indicates the type of the price item pricing. The valid values are: <ul style="list-style-type: none"> <li>• Regular</li> <li>• Post Processing</li> <li>• Post Processing – Invoice Based</li> <li>• Post Processing – Price Item Based</li> </ul> <b>Note:</b> This column appears only when the <b>Multi Price Parameter</b> option type of the <b>Multi Parameter Based Pricing (C1_PPARM_FLG)</b> feature configuration is set to <b>True</b> .
Copy	On clicking the <b>Copy</b> (  ) icon, the <b>Price Item Pricing</b> screen appears where you can define a new price item pricing using an existing price item pricing.

By default, the **Price List Price Items** zone does not appear in the **Price List** screen. It appears only when you click the **Broadcast** () icon corresponding to the price list in the **Search Price List** zone.

You can filter the list using various search criteria (such as, **Price Item** and **Effective Start Date**) available in the **Filter** area. By default, the **Filter** area is hidden. You can view the **Filter** area by clicking the **Filters** () icon in the upper right corner of this zone.

You can change the layout of this zone. For more information on how to change the layout, see [Changing the Layout](#) on page 2882.

### Related Topics

For more information on...	See...
How to view price items assigned to a price list	<a href="#">Viewing Price Items Assigned to a Price List</a> on page 372
How to remove a price item from the price list	<a href="#">Removing a Price Item from a Price List</a> on page 395
How to view price item pricing for the price list	<a href="#">View Price Item Pricing</a>

### Searching for a Price List

#### Prerequisites

To search for a price list, you should have:

- Divisions defined in the application

- Price list associated with the division to which the user belongs

### **Procedure**

To search for a price list:

1. Click the **Menu** link in the **Application** toolbar.  
A list appears.
2. From the **Main** menu, select **Pricing Management** and then click **Price List**.  
A sub-menu appears.
3. Click the **Search** option from the **Price List** sub-menu.  
The **Price List** screen appears.
4. Enter the search criteria in the **Search Price List** zone.

**Note:** ORMB search engine supports wildcard search, where you can substitute the percentage (%) symbol as a stand in for any word or letter in a search criteria. You can use the ‘%’ wildcard character in all input fields except the date and ID fields. The ‘%’ wildcard character is suffixed automatically at the end of the partial search criteria. Therefore, you may or may not specify the wildcard character at the end of the partial search criteria. However, you have to prefix the wildcard character manually wherever required.

5. Click **Search**.

A list of price lists that meet the search criteria appears in the **Search Results** section.

**Note:** Pagination is used to display limited number of records in the **Search Results** section. You can use the navigation links, such as **Previous** and **Next** to navigate between pages.

### **Related Topics**

<b>For more information on...</b>	<b>See...</b>
<b>Price List</b> screen	<a href="#">Price List (Used for Viewing)</a> on page 382
<b>Search Price List</b> zone	<a href="#">Search Price List</a> on page 367

### **Viewing Price Items Assigned to a Price List**

#### **Prerequisites**

To view price items assigned to a price list, you should have:

- An algorithm defined using the **C1-PLPINFO** algorithm type and attached to **Pricelist Products Assignment Information** system event in the **Algorithms** tab of the **Installation Options – Framework** screen

#### **Procedure**

To view price items assigned to a price list:

1. Search for the price list in the **Price List** screen.
2. In the **Search Results** section, click the **Broadcast**  icon corresponding to the price list whose price items details you want to view.  
The **Price List Price Items** zone appears.
3. View the price items that are assigned to the price list in the **Price List Price Items** zone.

### **Related Topics**

<b>For more information on...</b>	<b>See...</b>
How to search for a price list	<a href="#">Searching for a Price List</a> on page 371
<b>Price List Price Items</b> zone	<a href="#">Price List Price Items</a> on page 370

## Defining a Price List

### Procedure

To define a price list:

1. Click the **Menu** link in the **Application** toolbar.  
A list appears.
2. From the **Main** menu, select **Pricing Management** and then click **Price List**.  
A sub-menu appears.
3. Click the **Add** option from the **Price List** sub-menu.

The **Price List** screen appears. It consists the following sections:

- **Main** - Used to specify basic details about the price list.
- **Hierarchy** - Used to associate the price list with one or more parent price lists for a particular duration.
- **Divisions** - Used to associate the price list with one or more divisions.
- **Eligibility** - Used to define eligibility criteria for the price list.
- **Characteristics** - Used to define characteristics for the price list.

The **Main** section contains the following fields:

Field Name	Field Description	Mandatory (Yes or No)
Price List Description	Used to specify the description for the price list.	Yes
Effective Start Date	Used to specify the date from when the price list is effective. <b>Note:</b> By default, the current date appears in this field.	Yes
Effective End Date	Used to specify the date till when the price list is effective. <b>Note:</b> The effective end date cannot be earlier than the effective start date.	No
Price List Type	Used to indicate the type of the price list. The valid values are: <ul style="list-style-type: none"> <li>• Standard</li> <li>• Promotional</li> </ul> <b>Note:</b> By default, the <b>Standard</b> option is selected.	Yes

Field Name	Field Description	Mandatory (Yes or No)
Global Price List	Used to indicate whether the price list is a global price list. The valid values are: <ul style="list-style-type: none"> <li>• Yes</li> <li>• No</li> </ul>	Yes
Availability Start Date	Used to the specify the date from when the price list is available for assignment to an account or a person. <div style="border: 1px solid black; padding: 5px;"> <p><b>Note:</b> At present, the availability start date is not used in the price item while assigning a price list to an account or a person. It is available for future use.</p> </div>	No
Availability End Date	Used to the specify the date till when the price list is available for assignment to an account or a person. <div style="border: 1px solid black; padding: 5px;"> <p><b>Note:</b> The availability end date cannot be earlier than the availability start date. At present, the availability end date is not used in the price item while assigning a price list to an account or a person. It is available for future use.</p> </div>	No
Validity Period (in Days)	Used to specify the period in days for which the price list is valid. It is used to calculate price list assignment validity end date while assigning the price list to an account or a person.	No
Status	Used to indicate the status of the price list. The valid values are: <ul style="list-style-type: none"> <li>• <b>Active</b> - Used to indicate that the price list is used for billing.</li> <li>• <b>Proposed</b> - Used to indicate that the price list is used for quotations.</li> <li>• <b>Template</b> - Used to indicate that the price list is a template price list.</li> </ul> <div style="border: 1px solid black; padding: 5px;"> <p><b>Note:</b> By default, the <b>Active</b> option is selected.</p> </div>	Yes

**Tip:** Alternatively, you can access the **Price List** screen by clicking the **Add** button in the **Page Title** area of the **Price List** screen.

4. Enter the required details in the **Main** section.

**Note:** By default the **Main** section is displayed.

5. Click the **Show All** link from the **Section** to view all the sections and define or associate the following:
  - Associate the price list with one or more parent price list, if required.
  - Associate price list with one or more divisions, if required.
  - Define eligibility criteria for the price list, if required.

- Define characteristics for the price list, if required.

6. Click **Save**.

**Note:** The price list ID is generated automatically when the price list is created.

### Related Topics

For more information on...	See...
Price List screen	<a href="#">Price List (Used for Viewing)</a> on page 382
Price List screen	<a href="#">Price List (Used for Searching)</a> on page 367
How to define the price list hierarchy	<a href="#">Defining the Price List Hierarchy</a> on page 375
How to define characteristics for a price list	<a href="#">Defining a Characteristic for a Price List</a> on page 376
How to associate a price list with a division	<a href="#">Associating a Price List with a Division</a> on page 378
How to define eligibility criteria for a price list	<a href="#">Defining Eligibility Criteria for a Price List</a> on page 378

### Defining the Price List Hierarchy

Oracle Revenue Management and Billing allows you to define the price list hierarchy. It helps you to inherit the price item pricing from the parent price list if the price item pricing is not available in the price list (assigned to the account, person, or parent person). And, if the price item pricing is not available in the parent price list, the system will search for the price item pricing in the parent's parent price list (i.e. in the grandparent price list) and continue till it reaches the last level in the hierarchy.

In other words, when you define the price list hierarchy and assign the price list to an account or a person, the account or person can avail the price item pricing listed on the parent or grandparent price list if it is not available on the assigned price list. However, if the price item pricing is available on both the assigned and parent price lists, the system derives the price item pricing from the assigned price list.

You can define multiple parent price lists for a price list. But, only one parent price list is effective for a particular duration. Two or more price lists can have the same parent price list.

### Procedure

To define the price list hierarchy:

1. Click the **Hierarchy** or **Show All** link from the **Section** in the **Price List** screen when you are defining, editing, or copying a price list.

The **Hierarchy** section appears. It contains the following fields in a grid:

Field Name	Field Description	Mandatory (Yes or No)
Parent Price List Effective From Date	Used to specify the date from when the price list inherits pricing from the parent price list.	Yes (Conditional) <b>Note:</b> This field is required when you are associating the price list with a parent price list.
Parent Price List Effective To Date	Used to specify the date till when the price list inherits pricing from the parent price list. <b>Note:</b> The parent price list effective to date cannot be earlier than the parent price list effective from date and later than price list effective end date.	No

Field Name	Field Description	Mandatory (Yes or No)
Parent Price List	<p>Used to specify the parent price list ID to which you want to associate the price list.</p> <p><b>Note:</b></p> <p>The <b>Search</b>  icon appears corresponding to this field. On clicking the <b>Search</b> icon, the <b>Price List Search</b> window appears.</p> <p>On specifying the parent price list, the description of the parent price list appears corresponding to the <b>Parent Price List</b> field.</p>	<p>Yes (Conditional)</p> <p><b>Note:</b> This field is required when you are associating the price list with a parent price list.</p>

- Enter the required details in the **Hierarchy** section.

**Note:** You can search for a price list by clicking the **Search**  icon corresponding to the **Parent Price List** field.

- If you want to associate the price list with more than one parent price list, click the **Add**  icon corresponding to the parent price list and then repeat step 2.

**Note:**

You can associate a price list with multiple parent price lists. But, only one parent price list is effective for a particular duration. Also, while associating a price list with a parent price list, you can only specify a price list which is effective during the specified duration.

If you want to remove a parent price list from the price list hierarchy, click the **Delete**  icon corresponding to the parent price list.

- Click **Save**.

The price list is associated with the parent price lists.

### **Related Topics**

For more information on...	See...
How to define a price list	<a href="#">Defining a Price List</a> on page 373
How to edit a price list	<a href="#">Editing a Price List</a> on page 385
How to copy a price list	<a href="#">Copying a Price List</a> on page 380

### **Defining a Characteristic for a Price List**

#### **Prerequisites**

To define a characteristic for a price list, you should have:

- Characteristic types defined in the application (where the characteristic entity is set to **Price List**)

#### **Procedure**

To define a characteristics for a price list:

- Click the **Characteristics** or **Show All** link from the **Section** in the **Price List** window when you are defining, editing, or copying a price list.

The **Characteristics** section appears. It contains the following fields in a grid:



Field Name	Field Description	Mandatory (Yes or No)
Effective Date	Used to specify the date from when the characteristic is effective for the price list.	Yes (Conditional) <b>Note:</b> This field is required when you are defining a characteristic for the price list.
Characteristic Type	Used to indicate the characteristic type. <b>Note:</b> The list includes only those characteristic types where the characteristic entity is set to <b>Price List</b> .	Yes (Conditional) <b>Note:</b> This field is required when you are defining a characteristic for the price list.
Characteristic Value	Used to specify the value for the characteristic type. <b>Note:</b> The <b>Search</b>  icon appears corresponding to this field. On clicking the <b>Search</b> icon, the <b>Predefined Characteristic Search</b> window appears. On specifying the value for a predefined characteristic type, the description of the characteristic value appears corresponding to the <b>Characteristic Value</b> field.	Yes (Conditional) <b>Note:</b> This field is required when you are defining a characteristic for the price list.

- Enter the required details in the **Characteristics** section.

**Note:** If you select a predefined characteristic type, the **Search**  icon appears corresponding to the **Characteristic Value** field. On clicking the **Search** icon, you can search for a predefined characteristic value.

- If you want to define more than one characteristic for the price list, click the **Add**  icon and then repeat step 2.

**Note:** However, if you want to remove a characteristic from the price list, click the **Delete**  icon corresponding to the characteristic.

- Click **Save**.

The characteristics are defined for the price list.

### Related Topics

For more information on...	See...
How to define a price list	<a href="#">Defining a Price List</a> on page 373
How to edit a price list	<a href="#">Editing a Price List</a> on page 385
How to copy a price list	<a href="#">Copying a Price List</a> on page 380

## Associating a Price List with a Division

You can assign a price list only to those accounts or persons which belong to the division to which the price list is associated. Therefore, you need to associate the price list with appropriate divisions.

### Prerequisites

To associate a price list with a division, you should have:

- Divisions defined in the application

### Procedure

To associate a price list with a division:

1. Click the **Divisions** or **Show All** link from the **Section** in the **Price List** window when you are defining, editing, or copying a price list.

The **Divisions** section appears. It contains the following field in a grid:

Field Name	Field Description	Mandatory (Yes or No)
Division	Used to indicate the division to which you want to associate the price list.  <b>Note:</b> You can only view those divisions to which you have access in the <b>Division</b> list.	No

2. Select the required division from the list.
3. If you want to associate the price list with more than one division, click the **Add** (+) icon corresponding to the division and then repeat step 2.

**Note:** However, if you want to remove the price list from a division, click the **Delete** (🗑️) icon corresponding to the division.

4. Click **Save**.

The price list is associated with the divisions.

**Tip:** Alternatively, you can associate a price list with a division using the **Division** screen.

### Related Topics

For more information on...	See...
How to define a price list	<a href="#">Defining a Price List</a> on page 373
How to edit a price list	<a href="#">Editing a Price List</a> on page 385
How to copy a price list	<a href="#">Copying a Price List</a> on page 380

## Defining Eligibility Criteria for a Price List

### Prerequisites

To define eligibility criteria for a price list, you should have:

- The **Price List Eligibility Criteria** check box selected in the **Parameter Usage** section while defining the parameter

### Procedure

To define eligibility criteria for a price list:

1. Click the **Eligibility** or **Show All** link from the **Section** in the **Price List** screen when you are defining, editing, or copying a price list.

The **Eligibility** section appears. It contains the following fields in a grid:

Column Name	Column Description	Mandatory (Yes or No)
Criteria	On clicking the <b>Add</b> (  ) icon, you can associate eligibility criteria of parameters for the price list.	Yes (Conditional) <b>Note:</b> This field is required when you are defining an eligibility criteria for the price list.
Effective Start Date	Used to specify the date from when the criteria is effective for the price list.	Yes (Conditional) <b>Note:</b> This field is required when you are defining an eligibility criteria for the price list.
Effective End Date	Used to specify the date till when the criteria is effective for the price list.	No
Description	Used to specify the description for the criteria type.	Yes

2. Enter the required details in the **Eligibility** section.
3. If you want to define more than one eligibility criteria for the price list, click the **Add** () icon and then repeat step 2.

**Note:** However, if you want to remove the eligibility criteria, click the **Delete** () icon corresponding to the criteria.

4. Associate eligibility criteria of parameter for the price list, if required.
5. If you want to define more than one eligibility criteria of parameter for the price item, click the **Add** () icon corresponding to the parameter.

**Note:** However, if you want to remove the eligibility criteria of parameter for the price item, click the **Delete** () icon corresponding to the parameter.

6. Click **Save**.

The eligibility criteria are defined for the price list.

### Related Topics

For more information on...	See...
How to create a price list	<a href="#">Defining a Price List</a> on page 373
How to edit a price list	<a href="#">Editing a Price List</a> on page 385

<b>For more information on...</b>	<b>See...</b>
How to associate eligibility criteria of parameter for a price list	<a href="#">Associating Eligibility Criteria of Parameters for a Price List</a>

## Copying a Price List

Instead of creating a price list from scratch, you can create a new price list using an existing price list. This is possible through copying a price list. On copying a price list, the details including the pricing parameters, divisions, characteristics, eligibility criteria, and the assigned price items are copied to the new price list. You can then edit the details, if required.

### Prerequisites

To copy a price list, you should have:

- Price list (whose copy you want to create) defined in the application
- Price list (whose copy you want to create) associated with the division to which the user belongs

### Procedure

To copy a price list:

1. Search for the price list in the **Price List** screen.
2. In the **Search Results** section, click the **Copy** () icon in the **Copy** column corresponding to the price list using which you want to define a new price list.

The **Price List** screen appears. It contains the following sections:

- **Main** – Used to specify basic details about the price list.
- **Hierarchy** – Used to define parent price list for the price list for a particular duration.
- **Divisions** – Used to associate price list with one or more divisions.
- **Eligibility Criteria** – Used to define eligibility criteria for price list.
- **Characteristics** – Used to define characteristics (which are applicable across divisions) for the price list.

The **Main** section contains the following fields:

Field Name	Field Description	Mandatory (Yes or No)
Price List Description	Used to specify the description for the price list.	Yes
Effective Start Date	Used to specify the date from when the price list is effective	Yes
Effective End Date	Used to specify the date till when the price list is effective.	No
Price List Type	Used to indicate the type of the price list. The valid values are: <ul style="list-style-type: none"> <li>• Standard</li> <li>• Promotional</li> </ul>	Yes
Global Price List	Used to Indicate whether the price list is a global price list. The valid values are: <ul style="list-style-type: none"> <li>• Yes</li> <li>• No</li> </ul>	Yes

Field Name	Field Description	Mandatory (Yes or No)
Availability Start Date	Used to specify the date from when the price list is available for assignment to an account or a person.	Yes
Availability End date	Used to specify the date till when the price list is available for assignment to an account or a person.	No
Validity Period (in Days)	Used to specify the period in days for which the price list is valid. It is used to calculate price list assignment validity end date while assigning the price list to an account or a person.	Yes
Status	Used to indicate the status of the price list. The valid values are: <ul style="list-style-type: none"> <li>• Active</li> <li>• Proposed</li> <li>• Template</li> </ul>	Yes
Copy Pricing	Used to indicate whether you want to copy the pricing information to the price list. The valid values are: <ul style="list-style-type: none"> <li>• All</li> <li>• None</li> </ul>	Yes (Conditional)

3. Enter the required details in the **Main** section.
4. Add, edit, or remove the parent price list details, if required.
5. Associate or disassociate the price list from the required divisions.
6. Define, edit, or remove the price list eligibility criteria and parameter eligibility criteria for price list in the, if required.
7. Define, edit, or remove characteristics from the price list, if required.
8. Click **Save**.

The new price list is defined.

**Note:** The price list ID is generated automatically when the price list is defined.

### **Related Topics**

For more information on...	See...
How to search for a price list	<a href="#">Searching for a Price List</a> on page 371
How to define the price list hierarchy	<a href="#">Defining the Price List Hierarchy</a> on page 375
How to define characteristics for a price list	<a href="#">Defining a Characteristic for a Price List</a> on page 376
How to associate a price list with a division	<a href="#">Associating a Price List with a Division</a> on page 378
How to define eligibility criteria for the price list	<a href="#">Defining Eligibility Criteria for a Price List</a> on page 378

### **Viewing the Price List Details**

#### **Procedure**

To view the details of a price list:

1. Search for the price list in the **Price List** screen.
2. In the **Search Results** section, click the link in the **Price List Information** column corresponding to the price list whose details you want to view.

The **Price List** screen appears. It contains the following zones:

- [Price List](#) on page 382
  - [Eligibility Criteria](#) on page 384
  - [Price List Price Items](#) on page 370
3. View the basic details, hierarchy, divisions, and characteristics of the price list in the **Price List** zone.
  4. View the eligibility criteria to which the price list is associated in the **Eligibility Criteria** zone.
  5. View the price items that are assigned to the price list in the **Price List Price Items** zone.

### Related Topics

For more information on...	See...
How to search for a price list	<a href="#">Searching for a Price List</a> on page 371
<b>Price List</b> screen	<a href="#">Price List (Used for Viewing)</a> on page 382

## Price List (Used for Viewing)

The **Price List** screen allows you to view the details of a price list. It also allows you to edit a price list. It contains the following zones:

- **Price List** - Displays the basic details of the price list.
- **Eligibility Criteria** - Displays the eligibility criteria for the price list.
- **Price List Price Items** - Displays the price items that are assigned to the price list.

### Price List

The **Price List** zone displays the details of the price list. It contains the following sections:

- **Main** - Displays basic information about the price list. It contains the following fields:

Field Name	Field Description
Price List ID	Displays the price list ID.
Price List Description	Displays the description for the price list.
Effective Start Date	Displays the date from when the price list is effective.
Effective End Date	Displays the date till when the price list is effective.
Price List Type	Indicates the type of the price list. The valid values are: <ul style="list-style-type: none"> <li>• Standard</li> <li>• Promotional</li> </ul>
Global Price List	Indicates whether the price list is a global price list. The valid values are: <ul style="list-style-type: none"> <li>• Yes</li> <li>• No</li> </ul>
Availability Start Date	Displays the date from when the price list is available for assignment to an account or a person.

Field Name	Field Description
Availability End date	Displays the date till when the price list is available for assignment to an account or a person.
Validity Period (in Days)	Displays the period in days for which the price list is valid. It is used to calculate price list assignment validity end date while assigning the price list to an account or a person.
Status	Indicates the status of the price list. The valid values are: <ul style="list-style-type: none"> <li>• <b>Active</b> – Indicates that the price list is used for billing.</li> <li>• <b>Proposed</b> – Indicates that the price list is used for quotations.</li> <li>• <b>Template</b> – Indicates that the price list is a template price list.</li> </ul>

- **Hierarchy** - Lists the parent price list from which the price list has inherited the price item pricing for a particular duration. It contains the following columns:

Column Name	Column Description
Parent Price List ID	Displays the ID of the parent price list.
Parent Price List Effective From Date	Displays the date from when the price list can inherit pricing from the parent price list.
Parent Price List Effective To Date	Displays the date till when the price list can inherit pricing from the parent price list.

- **Divisions** - Lists the divisions to which the price list is associated. It contains the following column:

Column Name	Column Description
Division	Displays the division to which the price list is associated.  <b>Note:</b> It has a link. On clicking the link, the <b>Division</b> screen appears where you can view the details of the respective division.

- **Characteristics** - Lists the characteristics that are associated with the price list. It contains the following columns:

Column Name	Column Description
Effective Date	Displays the date from when the characteristic is effective for the price list.
Characteristic Type	Displays the characteristic type.
Characteristic Value	Displays the value for the characteristic type.

- **Record Actions** - This section contains the following button:

Button Name	Button Description
Edit	Used to edit the details of the price list.

- **Record Information** - This section contains the following field:

Field Name	Field Description
Business Object	Indicates the business object using which the price list is created. In addition, a context menu appears corresponding to this field which helps in navigating to other screens in the application.  <b>Note:</b> It has a link. On clicking the link, the <b>Business Object</b> screen appears where you can view the details of the respective business object.

### Related Topics

For more information on...	See...
Price List screen	<a href="#">Price List (Used for Viewing)</a> on page 382
How to edit a price list	<a href="#">Editing a Price List</a> on page 385

### Eligibility Criteria

The **Eligibility Criteria** zone lists the eligibility criteria of the price list. It contains the following columns:

Field Name	Field Description
Effective Start Date	Displays the date from when the criteria is effective for the price list.
Effective End Date	Displays the date till when the criteria is effective for the price list.
Description	Displays the description for the criteria type.
Sequence	Indicates the order in which the price list eligibility criteria should be executed.
Parameter	Indicates the parameter (on the left hand side) is used in the pricing eligibility criteria.
Operator	Displays the relational operator to define the relation between the parameter name and value.
Parameter Value Type	Indicates whether the parameter (on the left hand side) must be compared against another parameter (on the right hand side) or directly against a parameter value.
Parameter	Indicates the parameter (on the right hand side) against which you want to compare the parameter (on the left hand side).
Parameter Value	Indicates the parameter value against which you want to compare the parameter (on the left hand side).
Is True	Indicates what happens when the condition is true (satisfied). The valid values are: <ul style="list-style-type: none"> <li>• <b>Check Next Condition</b> – Indicates that the condition with consecutive sequence number should be executed.</li> <li>• <b>Rule Is False</b> – Indicates that the action specified in the <b>Rule False Action</b> field should be executed</li> <li>• <b>Rule Is True</b> – Indicates that the action specified in the <b>Rule True Action</b> field should be executed.</li> </ul>



Field Name	Field Description
Is False	<p>Indicates what happens when the condition is false (not satisfied). The valid values are:</p> <ul style="list-style-type: none"> <li>• <b>Check Next Condition</b> – Indicates that the condition with consecutive sequence number should be executed.</li> <li>• <b>Rule Is False</b> – Indicates that the action specified in the <b>Rule False Action</b> field should be executed</li> <li>• <b>Rule Is True</b> – Indicates that the action specified in the <b>Rule True Action</b> field should be executed.</li> </ul>
Is Insufficient	<p>Indicates what happens when the data is insufficient. The valid values are:</p> <ul style="list-style-type: none"> <li>• <b>Check Next Condition</b> – Indicates that the condition with consecutive sequence number should be executed.</li> <li>• <b>Rule Is False</b> – Indicates that the action specified in the <b>Rule False Action</b> field should be executed</li> <li>• <b>Rule Is True</b> – Indicates that the action specified in the <b>Rule True Action</b> field should be executed.</li> </ul>

### Related Topics

For more information on...	See...
Price List screen	<a href="#">Price List (Used for Viewing)</a> on page 382

## Editing a Price List

### Procedure

To edit a price list:

1. Search for the price list in the **Price List** screen.
2. In the **Search Results** section, click the link in the **Price List Information** column corresponding to the price list whose details you want to edit.

The **Price List** screen appears.

3. Click the **Edit** button in the **Price List** zone.

The **Price List** screen appears. It contains the following sections:

- **Main** - Used to specify basic details about the price list.
- **Hierarchy** - Used to define parent price list to inherit price item pricing for the price list for a particular duration.
- **Divisions** - Used to associate price list with one or more divisions.
- **Eligibility Criteria** - Used to define eligibility criteria for the price list.
- **Characteristics** - Used to define characteristics (which are applicable across divisions) for the price list.

The **Main** section contains the following fields:

Field Name	Field Description	Mandatory (Yes or No)
Price List Description	Used to specify the description for the price list.	Yes

Field Name	Field Description	Mandatory (Yes or No)
Effective Start Date	Used to specify the date from when the price list is effective.  <b>Note:</b> The system will not allow you to change the effective start date when: <ul style="list-style-type: none"> <li>• There is a price item assigned to the price list on that date.</li> <li>• The price list is assigned to an account or a person on that date.</li> </ul>	Yes
Effective End Date	Used to specify the date till when the price list is effective.  <b>Note:</b> The effective end date cannot be earlier than the effective start date.	No
Price List Type	Used to indicate the type of the price list. The valid values are: <ul style="list-style-type: none"> <li>• Standard</li> <li>• Promotional</li> </ul>	Yes
Global Price List	Used to indicate whether the price list is a global price list. The valid values are: <ul style="list-style-type: none"> <li>• Yes</li> <li>• No</li> </ul>	Yes
Availability Start Date	Used to the specify the date from when the price list is available for assignment to an account or a person.  <b>Note:</b> At present, the availability start date is not used in the product while assigning a price list to an account or a person. It is available for future use.	No
Availability End Date	Used to the specify the date till when the price list is available for assignment to an account or a person.  <b>Note:</b> The availability end date cannot be earlier than the availability start date.  At present, the availability end date is not used in the product while assigning a price list to an account or a person. It is available for future use.	No
Validity Period (in Days)	Used to specify the period in days for which the price list is valid. It is used to calculate price list assignment validity end date while assigning the price list to an account or a person.	No

Field Name	Field Description	Mandatory (Yes or No)
Status	<p>Used to indicate the status of the price list. The valid values are:</p> <ul style="list-style-type: none"> <li>• <b>Active</b> – Used to indicate that the price list is used for billing. This value appears only when you are editing a proposed price list</li> <li>• <b>Proposed</b> – Used to indicate that the price list is used for quotations.</li> <li>• <b>Template</b> – Used to indicate that the price list is a template price list.</li> </ul> <p><b>Note:</b> You cannot change the status of an active and a template price list.</p>	Yes

4. Modify the details in the **Main** section, if required.

**Note:** By default the **Main** section is displayed.

5. Add, edit or remove parent price list from the price list hierarchy, if required.
6. Associate or disassociate the price list from the divisions, if required.

**Note:** You can only view those divisions to which you have access in the **Division** list. If the price list is associated to a division to which you do not have access, then the **Divisions** section is grayed out.

7. Define, edit, or remove eligibility criteria from the price list, if required
8. Define, edit, or remove characteristics from the price list, if required.
9. Click **Save**.

The changes made to the price list are saved.

### **Related Topics**

For more information on...	See...
How to search for a price list	<a href="#">Searching for a Price List</a> on page 371
How to define the price list hierarchy	<a href="#">Defining the Price List Hierarchy</a> on page 375
How to define characteristics for a price list	<a href="#">Defining a Characteristic for a Price List</a> on page 376
How to associate a price list with a division	<a href="#">Associating a Price List with a Division</a> on page 378
How to define eligibility criteria for the price list	<a href="#">Defining Eligibility Criteria for a Price List</a> on page 378

## **Price List Price Item Pricing**

Once a price list is created, you can either assign a price item to the price list and then define pricing for the price item, or you can copy an existing price item pricing and assign it to the price list. The **Price List Price Item Pricing** screen allows you to:



- View and filter the price items that are assigned to the price list
- Search and assign price items to the price list
- Copy a price item pricing and assign it to the price list

This screen consists of the following zones:

- [Price List Price Items](#) on page 388
- [Search Price Item](#) on page 389

### Price List Price Items

The **Price List Price Items** zone lists price items that are assigned to the price list. You will not find any records in this zone if the price list does not have any price items assigned to it. This zone contains the following columns:

Column Name	Column Description
Pricing Information	Displays the details of price item pricing.
Pricing Parameters	Displays a comma-separated list of parameter values. The order in which parameter values appear in this column is controlled by the display order (which is defined while associating a parameter with a price item).  <b>Note:</b> This column appears only when the <b>Multi Price Parameter</b> option type of the <b>Multi Parameter Based Pricing (C1_PPARM_FLG)</b> feature configuration is set to <b>True</b> .
Pricing Status	Indicates the status of the price item pricing. The valid values are: <ul style="list-style-type: none"> <li>• Active</li> <li>• Inactive</li> <li>• Proposed</li> <li>• Rejected</li> <li>• Template</li> </ul>
Effective Start Date	Displays the date from when the price item pricing is effective for the price list.
Effective End Date	Displays the date till when the price item pricing is effective for the price list.
Price Assignment Type	Indicates the type of the price item pricing. The valid values are: <ul style="list-style-type: none"> <li>• Regular</li> <li>• Post Processing</li> <li>• Post Processing – Invoice Based</li> <li>• Post Processing – Price Item Based</li> </ul> <b>Note:</b> This column appears only when the <b>Multi Price Parameter</b> option type of the <b>Multi Parameter Based Pricing (C1_PPARM_FLG)</b> feature configuration is set to <b>True</b> .
Edit	On clicking the <b>Edit</b> (  ) icon, you can edit the price item from the price list.
Delete	On clicking the <b>Delete</b> (  ) icon, you can remove the price item from the price list.  <b>Note:</b> The <b>Delete</b> icon appears in this column only when the price list is not yet assigned to any account or person.  This column appears only when the <b>Multi Price Parameter</b> option type of the <b>Multi Parameter Based Pricing (C1_PPARM_FLG)</b> feature configuration is set to <b>False</b> .

You can filter the list using various search criteria (such as, **Price Item** and **Effective Start Date**) available in the **Filter** area. By default, the **Filter** area is hidden. You can view the **Filter** area by clicking the **Filters** (  ) icon in the upper right corner of this zone.

You can change the layout of this zone. For more information on how to change the layout, see [Changing the Layout](#) on page 2882.

### **Related Topics**

<b>For more information on...</b>	<b>See...</b>
How to edit a price item from the price list	<a href="#">Editing a Price Item Pricing</a>
How to remove a price item from the price list	<a href="#">Removing a Price Item from a Price List</a> on page 395

### **Search Price Item**

You can assign a price item or price item bundle to a price list and then define pricing for the price item or price item bundle, or you can copy an existing price item pricing and assign it to a price list. The **Search Price Item** zone allows you to search for a price item pricing which is assigned to an account, person, or a price list. You can then create a new price item pricing using an existing price item pricing through copying the price item pricing. Once you create a copy of an existing price item pricing, the new price item pricing is assigned to the price list. On copying a price item pricing, the pricing details including the price components, eligibility and tiering criteria for each price component, and characteristics are copied to the new price item pricing. You can then edit the details, if required.

The system allows you to create a copy of active, proposed, inactive, rejected, and template price item pricing. Once you create the copy of a template price item pricing, you can save the new price item pricing in either **Active** or **Proposed** status.

The **Search Price Item** zone contains the following two sections:

- **Search Criteria** – The **Search Criteria** section contains the following fields:

<b>Field Name</b>	<b>Field Description</b>	<b>Mandatory (Yes or No)</b>
Search By	Used to indicate whether you want to search price item, pricing assigned to price list and override pricing for an account, or person. The valid values are: <ul style="list-style-type: none"> <li>• Price Item</li> <li>• Price list Pricing</li> <li>• Account Override Pricing</li> <li>• Person Override Pricing</li> </ul>	Yes
Price Item	Used to search a particular price item or price item bundle.	No
Description	Used to search price items or price item bundles with a particular description. <div style="border: 1px solid black; padding: 5px; margin-top: 10px;"> <p><b>Note:</b> This field appears only when you select the <b>Price Item</b> option from the <b>Search By</b> list.</p> </div>	No
Global Price List	Used to search price items or price item bundles which can be assigned to a global price list. The valid values are: <ul style="list-style-type: none"> <li>• Yes</li> <li>• No</li> </ul>	No



Field Name	Field Description	Mandatory (Yes or No)
Bundle	Used to indicate whether you want to search for price item bundles. The valid values are: <ul style="list-style-type: none"> <li>• Yes</li> <li>• No</li> </ul>	No
Price List ID	Used to search pricing of price items or price item bundles which are assigned to a particular price list. <div style="border: 1px solid black; padding: 2px;"><b>Note:</b> This field appears only when you select the <b>Price List Pricing</b> option from the <b>Search By</b> list.</div>	No
Effective Start Date	Used to search price item pricing on price lists which are effective from a particular date onwards. <div style="border: 1px solid black; padding: 2px;"><b>Note:</b> This field appears only when you select the <b>Price List Pricing, Account Override Pricing, or Person Override Pricing</b> option from the <b>Search By</b> list.</div>	No
Effective End Date	Used to search price item pricing on price lists which are effective till a particular date. <div style="border: 1px solid black; padding: 2px;"><b>Note:</b> This field appears only when you select the <b>Price List Pricing, Account Override Pricing, or Person Override Pricing</b> option from the <b>Search By</b> list.</div>	No
Pricing Status	Used to search price item pricing with a particular status. The valid values are: <ul style="list-style-type: none"> <li>• Active</li> <li>• Inactive</li> <li>• Proposed</li> <li>• Rejected</li> <li>• Template</li> </ul> <div style="border: 1px solid black; padding: 2px;"><b>Note:</b> This field appears only when you select the <b>Price List Pricing, Account Override Pricing, or Person Override Pricing</b> option from the <b>Search By</b> list.</div>	No
Price Assignment Type	Used to search a particular type of the price item pricing. The valid values are: <ul style="list-style-type: none"> <li>• Regular</li> <li>• Post Processing</li> <li>• Post Processing – Invoice Based</li> <li>• Post Processing – Price Item Based</li> </ul> <div style="border: 1px solid black; padding: 2px;"><b>Note:</b> This field appears only when you select the <b>Price List Pricing, Account Override Pricing, or Person Override Pricing</b> option from the <b>Search By</b> list.</div>	No

Field Name	Field Description	Mandatory (Yes or No)
Account ID	Used to search pricing of price items or price item bundles which are assigned to a particular account.  <b>Note:</b> This field appears only when you select the <b>Account Override Pricing</b> option from the <b>Search By</b> list.	Yes
Person ID	Used to search pricing of price items or price item bundles which are assigned to a particular person.  <b>Note:</b> This field appears only when you select the <b>Person Override Pricing</b> option from the <b>Search By</b> list.	Yes

**Note:**  
You must specify at least one search criterion while searching for a price item or price item bundle.  
You can search for an account, person by clicking the **Search**  icon corresponding to the respective field.

- **Search Results** – On clicking the **Search** button, the search results appear based on the specified search criteria. The search results include only those price items or price item bundles that are associated with the division to which the price list belongs. It may also include price items or price item bundles that are already assigned to the price list in case those price items or price item bundles match the search criteria.

The **Search Results** section contains the following columns:

Column Name	Column Description
Assign	On clicking the <b>Assign</b>  icon, the <b>Price Item Pricing</b> screen appears where you can define a new price item pricing.
Price Item Information	Displays details of the price item or price item bundle.  <b>Note:</b> It has a link. On clicking the link, the <b>Price Item</b> screen appears where you can view the details of the respective price item or price item bundle.
Copy	On clicking the <b>Copy</b>  icon, the <b>Price Item Pricing</b> screen appears where you can define a new price item pricing using an existing price item pricing.
Pricing Information	Displays details of the price item pricing.  <b>Note:</b> It has a link. On clicking the link, the <b>View Price Item Pricing</b> window appears with the details of the respective price item pricing.

Column Name	Column Description
Account Information	<p>Indicates the account to which the price item pricing is assigned. In addition, this column has a context menu which helps in navigating to other screens in the application.</p> <div data-bbox="570 321 1463 657" style="border: 1px solid black; padding: 5px;"> <p><b>Note:</b></p> <p>This column appears only when you select the <b>Account Override Pricing</b> option from the <b>Search By</b> list.</p> <p>It has a link. On clicking the link, the <b>Account</b> screen appears where you can view the details of the respective account.</p> <p>The account information string appears only when an algorithm defined using the <b>C1-AC-INFO</b> algorithm type is attached to the <b>Account Information</b> system event in the <b>Algorithms</b> tab of the <b>Installation Options – Framework</b> screen.</p> </div>
Person Information	<p>Indicates the person to which the price item pricing is assigned. In addition, this column has a context menu which helps in navigating to other screens in the application.</p> <div data-bbox="570 800 1463 1136" style="border: 1px solid black; padding: 5px;"> <p><b>Note:</b></p> <p>This column appears only when you select the <b>Person Override Pricing</b> option from the <b>Search By</b> list.</p> <p>It has a link. On clicking the link, the <b>Person</b> screen appears where you can view the details of the respective person.</p> <p>The person information string appears only when an algorithm defined using the <b>PERS-INFO</b> algorithm type is attached to the <b>Person Information</b> system event in the <b>Algorithms</b> tab of the <b>Installation Options – Framework</b> screen.</p> </div>
Price List Information	<p>Indicates the price list to which the price item pricing is assigned. In addition, this column has a context menu which helps in navigating to other screens in the application.</p> <div data-bbox="570 1276 1463 1507" style="border: 1px solid black; padding: 5px;"> <p><b>Note:</b></p> <p>This column appears only when you select the <b>Price List Pricing</b> option from the <b>Search By</b> list.</p> <p>It has a link. On clicking the link, the <b>Price List</b> screen appears where you can view the details of the respective person.</p> </div>
Variance Parameter	<p>Indicates the variance parameter which is used for defining the price item pricing.</p> <div data-bbox="570 1581 1463 1696" style="border: 1px solid black; padding: 5px;"> <p><b>Note:</b> This column appears only when the <b>Multi Price Parameter</b> option type of the <b>Multi Parameter Based Pricing (C1_PPARM_FLG)</b> feature configuration is set to <b>False</b>.</p> </div>



Column Name	Column Description
Pricing Parameters	<p>Displays a comma-separated list of parameter values. The order in which parameter values appear in this column is controlled by the display order (which is defined while associating a parameter with a price item or price item bundle).</p> <div style="border: 1px solid black; padding: 5px;"> <p><b>Note:</b> This column appears only when the <b>Multi Price Parameter</b> option type of the <b>Multi Parameter Based Pricing (C1_PPARM_FLG)</b> feature configuration is set to <b>True</b>.</p> </div>
Effective Start Date	Displays the date from when the price item pricing is effective.
Effective End Date	Displays the date till when the price item pricing is effective.
Pricing Currency	Indicates the currency in which the price item pricing is defined.
Pricing Status	<p>Indicates the status of the price item pricing. The valid values are:</p> <ul style="list-style-type: none"> <li>• Active</li> <li>• Inactive</li> <li>• Proposed</li> <li>• Rejected</li> <li>• Template</li> </ul>
Rate Schedule	Indicates the rate schedule which is used for defining the price item pricing.
Price Assignment Usage	<p>Indicates whether the price item pricing is applicable to all customers or only to new customers. The valid values are:</p> <ul style="list-style-type: none"> <li>• AC</li> <li>• NC</li> </ul>
Price Assignment Type	<p>Indicates the type of the price item pricing. The valid values are:</p> <ul style="list-style-type: none"> <li>• Regular</li> <li>• Post Processing</li> <li>• Post Processing – Invoice Based</li> <li>• Post Processing – Price Item Based</li> </ul> <div style="border: 1px solid black; padding: 5px;"> <p><b>Note:</b> This column appears only when the <b>Multi Price Parameter</b> option type of the <b>Multi Parameter Based Pricing (C1_PPARM_FLG)</b> feature configuration is set to <b>False</b>.</p> </div>
Price Item	<p>Displays the price item or price item bundle code.</p> <div style="border: 1px solid black; padding: 5px;"> <p><b>Note:</b> It has a link. On clicking the link, the <b>Price Item Pricing</b> screen appears where you can define the pricing for the respective price item or price item bundle.</p> </div>
Description	Displays the description of the price item or price item bundle.
Global Price List	<p>Indicates whether the price item or price item bundle can be assigned to a global price list. The valid values are:</p> <ul style="list-style-type: none"> <li>• Y</li> <li>• N</li> </ul>

Column Name	Column Description
Unit of Measure	Indicates the unit of measure associated with the price item or price item bundle.
Bundle	Indicates whether the price item is a bundle or not. The valid values are: <ul style="list-style-type: none"> <li>• Y</li> <li>• N</li> </ul>
Owner ID	Displays the ID of the person for whose account the price list is created.
Party ID	Displays the third party ID.
Price List ID	Indicates the price list to which the price item pricing is assigned. <div style="border: 1px solid black; padding: 5px; margin-top: 10px;"> <b>Note:</b> This column appears only when you select the <b>Price List Pricing</b> option from the <b>Search By</b> list. </div>
Price Assignment ID	Displays the price assignment ID.
Price Assignment Owner Type Flag	Displays whether price list or party is the owner of the price assignment.
Bundle Type	Indicates the type of the price item bundle. If the price item bundle is available for pricing and billing, the valid values are: <ul style="list-style-type: none"> <li>• Phantom</li> <li>• Ratio</li> <li>• Regular</li> </ul> <p>However, if the price item bundle is available for only pricing and the price item type is <b>Fees</b> then the valid value is <b>Regular</b>.</p> <div style="border: 1px solid black; padding: 5px; margin-top: 10px;"> <b>Note:</b> This column appears only when you select the <b>Yes</b> option from the <b>Bundle</b> list. </div>
Price Item Type	Indicates the type of the price item or price item bundle. The valid values are: <ul style="list-style-type: none"> <li>• Rate</li> <li>• Fees</li> </ul>

### Related Topics

For more information on...	See...
How to view price item pricing	<a href="#">View Price Item Pricing</a>
How to assign a price item to a price list	<a href="#">Assigning a Price Item to a Price List</a>
<b>Price Item Pricing</b> window	<a href="#">Price Item Pricing</a>
How to copy a price item pricing and assign it to a price list	<a href="#">Copying a Price Item Pricing</a>
How to view price items assigned to a price list	<a href="#">Viewing Price Items Assigned to a Price List</a> on page 394

### **Viewing Price Items Assigned to a Price List**

#### Procedure

To view price items assigned to a price list:

1. Search for the price list in the **Price List** screen.
2. In the **Search Results** section, click the **Price Item Pricing** () icon from the **Price Item Pricing** column corresponding to the price list whose price items you want to view.  
The **Price List Price Item Pricing** screen appears.
3. View the price items that are assigned to the price list in the **Price List Price Items** zone.



### Related Topics

For more information on...	See...
How to search for a price list	<a href="#">Searching for a Price List</a> on page 371
<b>Price List Price Item Pricing</b> screen	<a href="#">Price List Price Item Pricing</a> on page 387
<b>Price List Price Items</b> zone	<a href="#">Price List Price Items</a> on page 388

## Removing a Price Item from a Price List

### Procedure

To remove a price item from a price list:

1. Search for the price list in the **Price List** screen.
2. In the **Search Results** section, click the **Price List Pricing** () icon corresponding to the price list from which you want to remove a price item.  
The **Price List Price Item Pricing** screen appears.
3. Filter the list in the **Price List Price Items** zone, if required.
4. Click the **Delete** () icon in the **Delete** column corresponding to the price item that you want to remove from the price list.

A message appears confirming whether you want to remove the price item from the price list.

**Note:** The **Delete** icon appears in the **Delete** column only when the price list is not yet assigned to any account or person.

5. Click **OK**.

The price item is removed from the price list.

### Related Topics

For more information on...	See...
How to search for a price list	<a href="#">Searching for a Price List</a> on page 371

## Viewing a Price Item Pricing

### Procedure

To view a price item pricing and assignment details:

1. Search for the price list in the **Price List** screen.
2. In the **Search Results** section, click the **Price List Pricing** () icon corresponding to the price list whose details you want to view.  
The **Price List Price Item Pricing** screen appears.
3. Price assignments effective for the price list appears in the **Price List Price Items** zone.

- Click the link in the **Pricing Information** column corresponding to the price list whose pricing details you want to view.

The **Price Item Pricing** screen appears. It contains the following zones:

- Price Item Pricing** – Displays the price item pricing details. It contains the following sections:
  - Pricing Information** – Displays the pricing information of the price item.
  - TFM Information** – Displays the transaction feed management information of the price item.
  - Characteristics** – Displays the details of price item pricing characteristics.
  - Price Item and Parameter Information** – Displays the price item parameter details.
  - Record Actions** – Displays the record actions of the price item pricing.
  - Record Information** – Displays the record information of the price item pricing.
- Rate and Price Component Summary** – Displays the rate and price component summary of the price item.
- Rate Components** – Displays the rate components of the price item.
- Price Components** – Displays the details of price components of the price item.
- Tiering Criteria** – Displays the tiering criteria of the price item pricing.

**Note:** This zone appears only when **Tiering Type** for the rate component is **STEP** or **Threshold**

- Pricing Eligibility Criteria** – Displays the pricing eligibility criteria of the price item pricing.

**Note:** This zone appears only when eligibility checkbox is selected in the **Price Item Pricing** screen and details for pricing eligibility criteria is added in the **Price Component** screen.

- View the basic details of price item pricing in the **Price Item Pricing** zone.
- View the rate and price component summary of price item in the **Rate and Price Component Summary** zone.
- View the rate components of price item in the **Rate Components** zone.
- View the details of price components of price item in the **Price Components** zone.
- View the tiering criteria of price item pricing in the **Tiering Criteria** zone.
- View the pricing eligibility criteria of price item pricing in the **Pricing Eligibility Criteria** zone.

### **Related Topics**

<b>For more information on...</b>	<b>See...</b>
How to search for a price list	<a href="#">Searching for a Price List</a> on page 371
<b>Price List Price Item Pricing</b> screen	<a href="#">Price List Price Item Pricing</a> on page 387
<b>Price List Price Items</b> zone	<a href="#">Price List Price Items</a> on page 370
<b>Price Item Pricing</b> screen	<a href="#">Price Item Pricing (Used for Viewing)</a> on page 507
<b>Price Item Pricing</b> zone	<a href="#">Price Item Pricing</a> on page 508
<b>Rate and Price Component Summary</b> zone	<a href="#">Rate and Price Component Summary</a> on page 511
<b>Rate Components</b> zone	<a href="#">Rate Components</a> on page 512
<b>Price Components</b> zone	<a href="#">Price Components</a> on page 512
<b>Tiering Criteria</b> zone	<a href="#">Tiering Criteria</a> on page 514
<b>Pricing Eligibility Criteria</b> zone	<a href="#">Pricing Eligibility Criteria</a> on page 514

## Editing a Price Item Pricing of a Price List



### Prerequisites

To edit a price item pricing of a price list, you should have:

- Transactions mapped to the price item defined in the application
- Rate schedules, rate versions, rate components defined in the application
- Parameters associated with the price item (in case you want to define price item pricing based on those parameters)

### Procedure

To edit a price item pricing of a price list:

1. Search for the price list in the **Price List** screen.
2. In the **Search Results** section, click the **Price List Pricing** (  ) icon corresponding to the price list whose details you want to view.  
The **Price List Price Item Pricing** screen appears.
3. Price assignments effective for the price list appears in the **Price List Price Items** zone.
4. Click the **Edit** (  ) icon in the **Edit** column corresponding to the price item pricing whose details you want to edit.

The **Price Item Pricing** screen appears. It contains the following sections:

- **Main** – Used to specify basic details about the price item pricing.
- **TFM Information** – Used to specify the transaction feed management information about the price item pricing.

**Note:** This section appears in the **Price Item Pricing** screen only when the value for the **Show Default Values in Price Item Pricing** option type for **C1\_FM** feature configuration is set to **Y** and **Price Item Available For** is **Pricing and Billing**.

- **Characteristics** – Used to define characteristics for the price item pricing.
- **Price Item and Parameter Information** – Used to define the parameter details segment for the price item pricing.

**Note:** This section appears only when **Price Assignment Type** is **Regular**.

The **Main** section contains the following fields:

Field Name	Field Description	Mandatory (Yes or No)
Start Date	<p>Used to specify the date from when the price item pricing is effective.</p> <div data-bbox="548 321 1195 661" style="border: 1px solid black; padding: 5px;"> <p><b>Note:</b></p> <p>The effective start date cannot be later than the effective end date.</p> <p>If you change the effective start and end dates while editing a price item pricing, you need to specify the parameters which are effective during that date range.</p> <p>This field will be in read-only mode when the price assignment has been used.</p> </div>	Yes
End Date	<p>Used to specify the date till when the price item pricing is effective.</p> <div data-bbox="548 768 1195 850" style="border: 1px solid black; padding: 5px;"> <p><b>Note:</b> The effective end date cannot be earlier than the effective start date.</p> </div>	No

Field Name	Field Description	Mandatory (Yes or No)
Price Assignment Type	<p>Used to indicate the type of price assignment. The valid values are:</p> <ul style="list-style-type: none"> <li>• <b>Regular</b> – Used to indicate that the pricing must be used to generate regular bill segment.</li> <li>• <b>Post Processing</b> – Used to indicate that the pricing must be used to generate post processing bill segment. This type of price assignment can be done on usage accounts. The post processing bill segment is generated when you generate the bill for the usage account and not when you bill the usage account through an invoice account.</li> </ul> <div data-bbox="613 642 1198 884" style="border: 1px solid black; padding: 5px;"> <p><b>Note:</b> The post processing bill segment is generated when the <b>Post Processing Sequence (PPSEQ)</b> characteristic is defined for the price item and when the price item is associated with another price item using the <b>Price Item</b> relationship type.</p> </div> <ul style="list-style-type: none"> <li>• <b>Post Processing – Invoice Based</b> – Used to indicate that the pricing must be used to generate post processing bill segment. This type of price assignment can be done on an invoice account, and, as a result, the post processing bill segment is generated on the invoice account.</li> </ul> <div data-bbox="613 1108 1198 1192" style="border: 1px solid black; padding: 5px;"> <p><b>Note:</b> This will not be applicable for price item which are defined for <b>Only Pricing</b>.</p> </div> <ul style="list-style-type: none"> <li>• <b>Post Processing – Price Item Based</b> – Used to indicate that the pricing must be used to generate post processing bill segment. This type of price assignment can be done on both invoice and usage accounts, but the post processing bill segment is generated only on the invoice account.</li> </ul> <div data-bbox="613 1417 1198 1501" style="border: 1px solid black; padding: 5px;"> <p><b>Note:</b> This will not be applicable for price item which are defined for <b>Only Pricing</b>.</p> </div>	Yes
Pricing Eligibility	<p>Used to select pricing eligibility criteria for price item pricing.</p> <div data-bbox="548 1577 1198 1692" style="border: 1px solid black; padding: 5px;"> <p><b>Note:</b> This field will be enabled for selection if the checkbox is not selected. If the checkbox appears selected then this field will be in read-only mode.</p> </div>	No

Field Name	Field Description	Mandatory (Yes or No)
Pricing Status	<p>Used to indicate the status of the price assignment. The valid values are:</p> <ul style="list-style-type: none"> <li>• <b>Draft</b> – Indicates that the price assignment is created as a draft.</li> <li>• <b>Active</b> – Indicates that the price assignment is used for billing.</li> <li>• <b>Inactive</b> – Indicates that the price assignment is no longer used for billing.</li> <li>• <b>Proposed</b> – Indicates that the price assignment is to be used for quotations.</li> <li>• <b>Template</b> – Indicates that the price assignment is a template price list.</li> </ul> <div style="border: 1px solid black; padding: 5px; margin-top: 10px;"> <p><b>Note:</b> If a price assignment is in <b>Active</b> status, you can change its status to <b>Inactive</b>. If a price assignment is in <b>Draft</b> status, you cannot change its status to <b>Proposed</b>.</p> </div>	Yes
Pricing Currency	Used to indicate the currency in which you want to define the price item pricing.	Yes
Rate Schedule	<p>Used to specify the rate schedule that you want to use while defining price item pricing.</p> <div style="border: 1px solid black; padding: 5px; margin-top: 10px;"> <p><b>Note:</b> Rate schedules control how the bills for the price item will be calculated. The <b>Search</b> (🔍) icon appears corresponding to this field. On clicking the <b>Search</b> icon, the <b>Rate Schedule Search</b> screen appears.</p> </div>	Yes
Pricing Rule Type	<p>Used to indicate the pricing rule type. The valid value is:</p> <ul style="list-style-type: none"> <li>• Two-Dimensional</li> </ul>	<p>Yes (Conditional)</p> <div style="border: 1px solid black; padding: 5px; margin-top: 10px;"> <p><b>Note:</b> This field is required when you are editing a two-dimensional pricing rule.</p> </div>
Print Zero	<p>Used to indicate whether zero pricing should be displayed in the bill. The valid values are:</p> <ul style="list-style-type: none"> <li>• Yes</li> <li>• No</li> </ul> <div style="border: 1px solid black; padding: 5px; margin-top: 10px;"> <p><b>Note:</b> By default, <b>Yes</b> is selected.</p> </div>	Yes



Field Name	Field Description	Mandatory (Yes or No)
Price Assignment Usage	Used to indicate whether the price item pricing is applicable to all customers or only to new customers. The valid values are: <ul style="list-style-type: none"> <li>All Customers</li> <li>New Customers</li> </ul>	Yes
Pricing Frequency	Used to indicate pricing frequency for the price item. <div style="border: 1px solid black; padding: 2px;"> <b>Note:</b> This field appears only when <b>Price Item</b> is defined as <b>Only Pricing</b> and <b>Price Item Type</b> is defined as <b>Fees</b>. </div>	Yes

5. Modify the details in the **Main** section, if required.
6. Edit the TFM Information in a price item pricing, if required.
7. Edit the characteristics for a price item pricing, if required.
8. Edit the parameters for a price item pricing, if required.
9. Click **Save**.

The changes made to the price item pricing are saved.

### **Related Topics**

For more information on...	See...
<b>Price List Price Item Pricing</b> screen	<a href="#">Price List Price Item Pricing</a> on page 387
<b>Price List Price Items</b> zone	<a href="#">Price List Price Items</a> on page 370
How to search for a price list	<a href="#">Searching for a Price List</a> on page 371
How to define a price item pricing.	<a href="#">Defining a Price Item Pricing</a> on page 516
How to define characteristics for a price item pricing.	<a href="#">Defining Characteristics for a Price Item Pricing</a> on page 405
How to define parameters for a price item pricing.	<a href="#">Defining Parameters for a Price Item Pricing</a> on page 406
How to define TFM Information in a price item pricing.	<a href="#">Defining TFM Information in a Price Item Pricing</a> on page 407

### **Assigning a Price Item to a Price List**

#### **Prerequisites**

To assign a price item to a price list, you should have:

- Transactions mapped to the price item defined in the application
- Rate schedules, rate versions, and rate components defined in the application
- Parameters associated with the price item (in case you want to define price item pricing based on multiple parameters)

#### **Procedure**

To assign a price item to a price list:

1. Search for the price list in the **Price List** screen.

- In the **Search Results** section, click the **Price List Pricing** () icon corresponding to the price list whose details you want to view.

The **Price List Price Item Pricing** screen appears.

- Search for the price item that you want to assign to the price list in the **Search Price Item or Price Item Pricing** zone.
- In the **Search Results** section, click the **Assign** () icon in the **Assign** column corresponding to the price item that you want to assign to the price list.

The **Price Item Pricing** screen appears. It contains the following sections:

- Main** – Used to specify basic details about the price item pricing.
- TFM Information** – Used to specify the transaction feed management information about the price item pricing.

**Note:** This section appears in the **Price Item Pricing** screen only when the value for the **Show Default Values in Price Item Pricing** option type for **C1\_FM** feature configuration is set to **Y** and **Price Item Available For** is **Pricing and Billing**.

- Characteristics** – Used to define characteristics for the price item pricing.
- Price Item and Parameter Information** – Used to define the parameter details segment for the price item pricing.

**Note:** This section appears only when **Price Assignment Type** is **Processing**.

The **Main** section contains the following fields:

Field Name	Field Description	Mandatory (Yes or No)
Start Date	Used to specify the date from when the price item pricing is effective.  <b>Note:</b> By default, the current system date appears in this field. The effective start date cannot be later than the effective end date.	Yes
End Date	Used to specify the date till when the price item pricing is effective.  <b>Note:</b> The effective end date cannot be earlier than the effective start date.	No

Field Name	Field Description	Mandatory (Yes or No)
Price Assignment Type	<p>Used to indicate the type of price assignment. The valid values are:</p> <ul style="list-style-type: none"> <li>• <b>Regular</b> – Used to indicate that the pricing must be used to generate regular bill segment.</li> <li>• <b>Post Processing</b> – Used to indicate that the pricing must be used to generate post processing bill segment. This type of price assignment can be done on usage accounts. The post processing bill segment is generated when you generate the bill for the usage account and not when you bill the usage account through an invoice account.</li> </ul> <div data-bbox="610 642 1187 884" style="border: 1px solid black; padding: 5px;"> <p><b>Note:</b> The post processing bill segment is generated when the <b>Post Processing Sequence (PPSEQ)</b> characteristic is defined for the price item and when the price item is associated with another price item using the <b>Price Item</b> relationship type.</p> </div> <ul style="list-style-type: none"> <li>• <b>Post Processing – Invoice Based</b> – Used to indicate that the pricing must be used to generate post processing bill segment. This type of price assignment can be done on an invoice account, and, as a result, the post processing bill segment is generated on the invoice account.</li> </ul> <div data-bbox="610 1108 1187 1192" style="border: 1px solid black; padding: 5px;"> <p><b>Note:</b> This will not be applicable for price item which are defined for <b>Only Pricing</b>.</p> </div> <ul style="list-style-type: none"> <li>• <b>Post Processing – Price Item Based</b> – Used to indicate that the pricing must be used to generate post processing bill segment. This type of price assignment can be done on both invoice and usage accounts, but the post processing bill segment is generated only on the invoice account.</li> </ul> <div data-bbox="610 1417 1187 1501" style="border: 1px solid black; padding: 5px;"> <p><b>Note:</b> This will not be applicable for price item which are defined for <b>Only Pricing</b>.</p> </div>	Yes
Pricing Eligibility	Used to select pricing eligibility criteria for price item pricing.	No
Pricing Status	<p>Used to indicate the status of the price assignment. The valid values are:</p> <ul style="list-style-type: none"> <li>• <b>Draft</b> – Indicates that the price assignment is created as a draft.</li> <li>• <b>Proposed</b> – Indicates that the price assignment is used for quotations.</li> <li>• <b>Template</b> – Indicates that the price assignment is a template price list.</li> </ul>	Yes

Field Name	Field Description	Mandatory (Yes or No)
Pricing Currency	Used to indicate the currency in which you want to define the price item pricing.	Yes
Rate Schedule	Used to specify the rate schedule that you want to use while defining price item pricing.  <div style="border: 1px solid black; padding: 5px;"> <p><b>Note:</b> Rate schedules control how the bills for the price item will be calculated.  The <b>Search</b> (🔍) icon appears corresponding to this field. On clicking the <b>Search</b> icon, the <b>Rate Schedule Search</b> screen appears.</p> </div>	Yes
Pricing Rule Type	Used to indicate the pricing rule type. The valid value is: <ul style="list-style-type: none"> <li>Two-Dimensional</li> </ul>	Yes (Conditional)  <div style="border: 1px solid black; padding: 5px;"> <p><b>Note:</b> This field is required when you are defining a two-dimensional pricing rule.</p> </div>
Print Zero	Used to indicate whether zero pricing should be displayed in the bill. The valid values are: <ul style="list-style-type: none"> <li>Yes</li> <li>No</li> </ul> <div style="border: 1px solid black; padding: 5px;"> <p><b>Note:</b> By default, <b>Yes</b> is selected.</p> </div>	Yes
Price Assignment Usage	Used to indicate whether the price item pricing is applicable to all customers or only to new customers. The valid values are: <ul style="list-style-type: none"> <li>All Customers</li> <li>New Customers</li> </ul>	Yes
Pricing Frequency	Used to indicate pricing frequency for the price item.  <div style="border: 1px solid black; padding: 5px;"> <p><b>Note:</b> This field appears only when <b>Price Item</b> is defined as <b>Only Pricing</b> and <b>Price Item Type</b> is defined as <b>Fees</b>.</p> </div>	Yes

5. Enter the required details in the **Main** section.
6. Define TFM Information in a price item pricing, if required.
7. Define characteristics for a price item pricing, if required.
8. Define parameters for a price item pricing, if required.
9. Click **Save**.

The pricing is defined for the price item.

**Note:** A bundle cannot be assigned if its child price items are already assigned to a price list and vice versa, in the same date range.

### **Related Topics**

<b>For more information on...</b>	<b>See...</b>
<b>Price List Price Item Pricing</b> screen	<a href="#">Price List Price Item Pricing</a> on page 387
<b>Search Price Item or Price Item Pricing</b> zone	<a href="#">Search Price Item</a> on page 389
How to search for an person	<a href="#">Searching for a Price List</a> on page 371
How to define characteristics for a price item pricing.	<a href="#">Defining Characteristics for a Price Item Pricing</a> on page 405
How to define parameters for a price item pricing.	<a href="#">Defining Parameters for a Price Item Pricing</a> on page 406
How to define TFM Information in a price item pricing.	<a href="#">Defining TFM Information in a Price Item Pricing</a> on page 407

### **Defining Characteristics for a Price Item Pricing**

#### **Prerequisites**

To define characteristics for a price item pricing, you should have:

- Characteristic types defined in the application (where the characteristic entity is set to **Price Item**)

#### **Procedure**

To define characteristics for a price item pricing that is assigned to an account:

1. Ensure that the **Characteristics** section is expanded when you are defining a price item pricing.

The **Characteristics** section contains the following columns:

<b>Column Name</b>	<b>Column Description</b>	<b>Mandatory (Yes or No)</b>
Effective Date	Used to specify the date from when the characteristic is effective for the price item pricing.	Yes (Conditional) <b>Note:</b> This field is required when you are defining a characteristic for the price item pricing.
Characteristic Type	Used to indicate the characteristic type. <b>Note:</b> The list includes only those characteristic types where the characteristic entity is set to <b>Price Item Pricing</b> .	Yes (Conditional) <b>Note:</b> This field is required when you are defining a characteristic for the price item pricing.

Column Name	Column Description	Mandatory (Yes or No)
Characteristic Value	Used to specify the value for the characteristic type.  <b>Note:</b> If you select a predefined characteristic type, the <b>Search</b> (🔍) icon appears corresponding to the <b>Characteristic Value</b> field. On clicking the <b>Search</b> icon, the <b>Predefined Characteristic Search</b> window appears.  On specifying the value for a predefined characteristic type, the description of the characteristic value appears corresponding to the <b>Characteristic Value</b> field.	Yes (Conditional)  <b>Note:</b> This field is required when you are defining a characteristic for the price item pricing.

- Enter the required details in the **Characteristics** section.
- If you want to define more than one characteristic for the price item pricing, click the **Add** (+) icon and then repeat step 3.

**Note:** However, if you want to remove a characteristic from the price item pricing, click the **Delete** (🗑️) icon corresponding to the characteristic.

- Click **Save**.

The characteristics are defined for the price item pricing.

### **Related Topics**

For more information on...	See...
How to define a price item pricing	<a href="#">Defining a Price Item Pricing</a> on page 516
How to edit a price item pricing	<a href="#">Editing a Price Item Pricing</a> on page 560
How to override a price item pricing	<a href="#">Overriding a Price Item Pricing</a> on page 569

## **Defining Parameters for a Price Item Pricing**

### **Prerequisites**

To define parameters for a price item pricing, you should have:

- Parameters associated with the price item, in case, you want to define price item pricing based on multiple parameters

### **Procedure**

To define parameter details segment for a price item pricing that is assigned to an account:

- Ensure that the **Price Item and Parameter Information** section is expanded when you are defining a price item pricing.

The **Price Item and Parameter Information** section contains the following field:

Field Name	Field Description
Price Item	Indicates the price item or price item bundle whose pricing details are listed in this section.

In addition, this section contains a grid which has the following columns:

Column Name	Column Description	Mandatory (Yes or No)
Parameter	Used to indicate the parameter that you want to associate with the price item pricing.  <b>Note:</b> The <b>Search</b> (🔍) icon appears corresponding to this field. On clicking the <b>Search</b> icon, the <b>Price Item Parameter Search</b> window appears. The parameter search results displays only those parameters where the <b>Price Item</b> check box is selected	Yes
Parameter Information	Displays a comma-separated string which contains of the following: <ul style="list-style-type: none"> <li>Parameter Description</li> <li>Mandatory (Yes or No)</li> <li>Priority</li> </ul>	Not applicable
Parameter Value	Used to specify the value of the parameter.	Yes

- Enter the required details in the **Price Item and Parameter Information** section.
- If you want to define more than one parameter information for the price item pricing, click the **Add** (+) icon and then repeat step 2.

**Note:** However, if you want to remove a parameter information from the price item pricing, click the **Delete** (🗑️) icon corresponding to the parameter.

- Click **Save**.

The parameters are defined for the price item pricing.

### Related Topics

For more information on...	See...
How to define a price item pricing	<a href="#">Defining a Price Item Pricing</a> on page 516
How to edit a price item pricing	<a href="#">Editing a Price Item Pricing</a> on page 560
How to override a price item pricing	<a href="#">Overriding a Price Item Pricing</a> on page 569

## Defining TFM Information in a Price Item Pricing

### Prerequisites

To define the TFM information in a price item pricing, you should have:

- Transactions mapped to the price item defined in the application
- Aggregation or Rating Criteria data to be defined for the price item pricing

### Procedure

To define the TFM information in a price item pricing:

- Ensure that the **TFM Information** section is expanded when you are defining a price item pricing.

The **TFM Information** section contains the following fields:

Field Name	Field Description	Mandatory (Yes or No)
Ignore Transaction	Used to indicate whether the transactions mapped to the price item is considered for billing. The valid values are: <ul style="list-style-type: none"> <li>• Yes</li> <li>• No</li> </ul>	Yes
Aggregate Transactions	Used to indicate whether the transactions mapped to the price item is aggregated for billing. The valid values are: <ul style="list-style-type: none"> <li>• Yes</li> <li>• No</li> </ul>	Yes
Aggregation Schedule	Used to indicate the transaction aggregation cycle. The valid values are: <ul style="list-style-type: none"> <li>• Daily</li> <li>• Weekly</li> <li>• Monthly</li> <li>• Quaterly</li> <li>• Yearly</li> </ul>	Yes
Transaction Rating Criteria	Used to indicate how and when the transaction legs mapped to the price item are rated. The valid values are: <ul style="list-style-type: none"> <li>• Aggregate Transactions and Then Rate Aggregated SQs</li> <li>• Do Not Rate Transactions</li> <li>• Rate Transaction and Aggregate Calc Lines Across Transaction</li> </ul>	Yes

- Enter the required details in the **TFM Information** section.

**Note:** **TFM Information** section appears when the value for **Show Default Values in Price Item Pricing** option type of **C1\_FM feature configuration** is set to **Y** and **Price Item Available For** is **Pricing and Billing**.

- Click **Save**.

The transactions are defined for the price item pricing.

### **Related Topics**

For more information on...	See...
How to define a price item pricing for an account	<a href="#">Assigning a Price Item to an Account</a> on page 466
How to edit a price item pricing for an account	<a href="#">Editing a Price Item Pricing of an Account</a> on page 458
How to override a price item pricing for an account	<a href="#">Overriding a Price Item Pricing of an Account</a> on page 462
How to define a price item pricing for a person	<a href="#">Assigning a Price Item to a Person</a> on page 500
How to edit a price item pricing for a person	<a href="#">Editing a Price Item Pricing of a Person</a> on page 492
How to override a price item pricing for a person	<a href="#">Overriding a Price Item Pricing of a Person</a> on page 496



For more information on...	See...
How to define a price item pricing for a price list	<a href="#">Assigning a Price Item to a Price List</a> on page 401
How to edit a price item pricing for a price list	<a href="#">Editing a Price Item Pricing of a Price List</a> on page 397

## Price List Assignment

Once a price list is defined, you can assign it to accounts or persons to indicate the prices that will be charged for the price items or services offered to the accounts or persons. You can assign multiple price lists to an account or a person along with the priority or order in which the pricing should be considered. You can also define whether the account or person can avail the price item pricing listed on the parent or grandparent price list if it is not available on the assigned price list. In other words, you can define whether the account or person can inherit the price item pricing from the price list hierarchy.

For example, suppose you have PL1 (with priority 10) and PL2 (with priority 20) assigned to an account or a person. While determining pricing for a price item, the system will search for the price item pricing in PL1. If the system does not find the price item pricing in PL1, it will search for the price item pricing in PL2. The system will behave in this manner only when the price list inheritance for PL1 is set to **No** during the price list assignment.

If the price list inheritance while assigning PL1 and PL2 to an account or a person is set to **Yes**, the system will search for the price item pricing in PL1. If the system does not find the price item pricing in PL1, it will search for the price item pricing from the price list hierarchy defined for PL1. However, if the system does not find the price item pricing from the price list hierarchy of PL1, it will then search for the price item pricing in PL2 (assigned to the account or person with priority 20). If the system still does not find the price item pricing in PL2, it will search for the price item pricing from the price list hierarchy defined for PL2.

The **Price List Assignment** screen allows you to search and assign a price list to an account or a person. It also allows you to view the price lists that are already assigned to an account or a person. It contains the following zones:

- [Price List Assignments](#) on page 409
- [Price List Price Items](#) on page 411
- [Search Price List for Assignment](#)

### Price List Assignments

The **Price List Assignments** zone allows you to view and filter price lists that are currently assigned to the account or person. You can also search for the price lists assigned to the account or person which are either inactive or expired. You will not find any records in this zone if the account does not have any price lists assigned to it. It contains the following two sections:

- **Search Criteria** - The **Search Criteria** section contains the following fields:

Field Name	Field Description	Mandatory (Yes or No)
Search By	Used to indicate whether you want to search for the current, inactive, or historical price list assignments. The valid values are: <ul style="list-style-type: none"> <li>• Current Price List Assignments</li> <li>• Inactive Price List Assignments</li> <li>• Historical Price List Assignments</li> </ul> <div style="border: 1px solid black; padding: 2px; margin-top: 5px;"> <b>Note:</b> By default, the <b>Current Price List Assignments</b> option is selected. </div>	Yes

Field Name	Field Description	Mandatory (Yes or No)
Price List ID	Used to search a particular price list assigned to an account or a person.  <b>Note:</b> The <b>Search</b>  icon appears corresponding to the <b>Price List ID</b> field. On clicking the <b>Search</b> icon, the <b>Price List Search</b> window appears.	No
Price List Description	Used to search price lists which are assigned to the account or person having a particular description.	No
Effective Start Date	Used to search price lists which are assigned to the account or person from a particular date.	No
Effective End Date	Used to search price lists which are assigned to the account or person till a particular date.	No
Assignment Status	Used to search price list assignments with a particular status. The valid values are: <ul style="list-style-type: none"> <li>• Active</li> <li>• Rejected</li> <li>• Proposed</li> <li>• Inactive</li> </ul> <b>Note:</b> The <b>Inactive</b> option is not available in the <b>Assignment Status</b> list when you have selected the <b>Current Price List Assignments</b> or <b>Historical Price List Assignments</b> option from the <b>Search By</b> list. This field is disabled, and by default, the <b>Inactive</b> option is selected when you select the <b>Inactive Price List Assignments</b> option from the <b>Search By</b> list.	No
Price List Inheritance	Used to search price list assignments where the account or person inherits price item pricing from the price list hierarchy. The valid values are: <ul style="list-style-type: none"> <li>• Yes</li> <li>• No</li> </ul>	No

**Note:** You must specify at least one search criterion while searching for price list assignments.

- **Search Results** - On clicking the **Search** button, the search results appear based on the specified search criteria. The **Search Results** section contains the following columns:

Column Name	Column Description
Price List Information	Displays information about the price list which is assigned to the account or person.  <b>Note:</b> It has a link. On clicking the link, the <b>Price List</b> screen appears with the details of the respective price list.

Column Name	Column Description
Effective Start Date	Displays the date from when the price list is assigned to the account or person.
Effective End Date	Displays the date till when the price list is assigned to the account or person.
Priority	Indicates the order in which the assigned price list must be considered while determining the price item pricing for the account or person.
Assignment Status	Indicates the status of the price list assignment. The valid values are: <ul style="list-style-type: none"> <li>• Active</li> <li>• Rejected</li> <li>• Proposed</li> <li>• Inactive</li> </ul>
Price List Inheritance	Indicates whether the account or person can avail the price item pricing listed on the parent or grandparent price list if it is not available on the assigned price list. In other words, it indicates whether the account or person can inherit the price item pricing from the price list hierarchy.
Edit	On clicking the <b>Edit</b>  icon, the <b>Price List Assignment</b> screen appears where you can edit the price list assignment details.

**Note:** Pagination is used to display limited number of records in the **Search Results** section. You can use the navigation links, such as **Previous** and **Next** to navigate between pages.

On clicking the **Broadcast**  icon corresponding to the assigned price list, the **Price List Price Items** zone appears where you can view the price items assigned to the price list.

### **Related Topics**

For more information on...	See...
<b>Price List Price Items</b> zone	<a href="#">Price List Price Items</a> on page 388
How to view price items assigned to the price list	<a href="#">Viewing Price Items Assigned to a Price List</a> on page 417
How to edit the price list assignment details of an account	<a href="#">Editing the Price List Assignment Details of an Account</a> on page 425
How to edit the price list assignment details of a person	<a href="#">Editing the Price List Assignment Details of a Person</a> on page 428
How to view price lists assigned to an account	<a href="#">Viewing Price Lists Assigned to an Account</a> on page 415
How to view price lists assigned to a person	<a href="#">Viewing Price Lists Assigned to a Person</a> on page 416

### **Price List Price Items**

The **Price List Price Items** zone lists the price items that are assigned to the price list. You will not find any records in this zone if the price list does not have any price items assigned to it. It contains the following columns:

Column Name	Column Description
Pricing	Displays information about the price item pricing. <div style="border: 1px solid black; padding: 5px; margin-top: 10px;"> <p><b>Note:</b> It has a link. On clicking the link, the <b>Price Item Pricing</b> screen appears where you can view the details of the price item pricing.</p> </div>

Column Name	Column Description
Pricing Parameters	<p>Displays a comma-separated list of parameter values. The order in which parameter values appear in this column is controlled by the display order (which is defined while associating a parameter with a price item).</p> <p><b>Note:</b> This column appears only when the <b>Multi Price Parameter</b> option type of the <b>Multi Parameter Based Pricing (C1_PPARM_FLG)</b> feature configuration is set to <b>True</b>.</p>
Pricing Status	<p>Indicates the status of the price item pricing. The valid values are:</p> <ul style="list-style-type: none"> <li>• Active</li> <li>• Inactive</li> <li>• Proposed</li> <li>• Rejected</li> <li>• Template</li> </ul>
Effective Start Date	Displays the date from when the price item pricing is effective for the price list.
Effective End Date	Displays the date till when the price item pricing is effective for the price list.
Price Assignment Type	<p>Indicates the type of the price assignment for price item pricing. The valid values are:</p> <ul style="list-style-type: none"> <li>• Regular</li> <li>• Post Processing</li> <li>• Post Processing – Invoice Based</li> <li>• Post Processing – Price Item Based</li> </ul> <p><b>Note:</b> This column appears only when the <b>Multi Price Parameter</b> option type of the <b>Multi Parameter Based Pricing (C1_PPARM_FLG)</b> feature configuration is set to <b>True</b>.</p>
Copy	<p>On clicking the <b>Copy</b> () icon, the <b>Price Item Pricing</b> screen appears where you can define a new price item pricing using an existing price item pricing.</p>

By default, the **Price List Price Items** zone does not appear in the **Price List Assignment** screen. It appears only when you click the **Broadcast** () icon corresponding to the assigned price list in the **Price List Assignments** zone.

You can filter the list using various search criteria (such as, **Price Item** and **Effective Start Date**) available in the **Filter** area. By default, the **Filter** area is hidden. You can view the **Filter** area by clicking the **Filter** () icon in the upper right corner of this zone.

You can change the layout of this zone. For more information on how to change the layout, see [Changing the Layout](#) on page 2882.

### Related Topics

For more information on...	See...
How to view price items assigned to a price list	<a href="#">Viewing Price Items Assigned to a Price List</a> on page 417

### Search Price List for Assignment

The **Search Price List for Assignment** zone allows you to search for a price list that you want to assign to the account or person. It contains the following two sections:

- **Search Criteria** – The **Search Criteria** section contains the following fields:

Field Name	Field Description	Mandatory (Yes or No)
Search By	Used to indicate whether you want to search against all price lists or against those price lists which are already assigned to an account or a person. The valid values are: <ul style="list-style-type: none"> <li>• Price List</li> <li>• Assigned Price List</li> </ul> <div style="border: 1px solid black; padding: 2px; margin-top: 5px;"><b>Note:</b> By default, the <b>Price List</b> option is selected.</div>	Yes
Price List ID	Used to search a particular price list.	No
Price List Description	Used to search price lists with a particular description.	No
Effective Start Date	If you have selected the <b>Price List</b> option from the <b>Search By</b> list, this field is used to search price lists which are effective from a particular date onwards. However, if you have selected the <b>Assigned Price List</b> option from the <b>Search By</b> list, this field is used to search price lists which are assigned to an account or a person from a particular date onwards.	No
Effective End Date	If you have selected the <b>Price List</b> option from the <b>Search By</b> list, this field is used to search price lists which are effective till a particular date. However, if you have selected the <b>Assigned Price List</b> option from the <b>Search By</b> list, this field is used to search price lists which are assigned to an account or a person till a particular date.	No
Account ID	Used to search price lists assigned to a particular account. <div style="border: 1px solid black; padding: 2px; margin-top: 5px;"><b>Note:</b> This field appears only when you have selected the <b>Assigned Price List</b> option from the <b>Search By</b> list.</div>	No
Person ID	Used to search price lists assigned to a particular person. <div style="border: 1px solid black; padding: 2px; margin-top: 5px;"><b>Note:</b> This field appears only when you have selected the <b>Assigned Price List</b> option from the <b>Search By</b> list.</div>	No
Status	Used to search price lists with a particular status. The valid values are: <ul style="list-style-type: none"> <li>• Active</li> <li>• Proposed</li> </ul> <div style="border: 1px solid black; padding: 2px; margin-top: 5px;"><b>Note:</b> This field appears only when you have selected the <b>Price List</b> option from the <b>Search By</b> list.</div>	No

Field Name	Field Description	Mandatory (Yes or No)
Price List Type	Used to search a particular type of price lists. The valid values are: <ul style="list-style-type: none"> <li>Standard</li> <li>Promotional</li> </ul> <p><b>Note:</b> This field appears only when you have selected the <b>Price List</b> option from the <b>Search By</b> list.</p>	No
Only Eligible Price Lists	Used to search price lists which are eligible for the account or person. <p><b>Note:</b> This field appears only when you have selected the <b>Price List</b> option from the <b>Search By</b> list.</p>	No
Eligibility Date	Used to search price lists which are eligible for the account or person from a particular date. <p><b>Note:</b> This field appears only when you have selected the <b>Price List</b> option from the <b>Search By</b> list. By default, the current date appears in this field when the <b>Only Eligible Price Lists</b> option is selected. You can change the value, if required.</p>	No

**Note:** You must specify at least one search criterion while searching for a price list.

- **Search Results** – On clicking the **Search** button, the search results appear based on the specified search criteria. The search results include only those price lists that are associated with the division to which the account belongs. It may also include price lists that are already assigned to the account in case those price lists match the search criteria.

The **Search Results** section contains the following columns:

Column Name	Column Description
Assign	On clicking the <b>Assign</b> (  ) icon, the <b>Price List Assignment</b> screen appears where you can assign the price list to the account or person.
Price List Information	Displays the information about the price list. <p><b>Note:</b> It has a link. On clicking the link, the <b>Price List</b> screen appears where you can view the details of the respective price list.</p>
Account Information	Displays the information about the account. <p><b>Note:</b> It has a link. On clicking the link, the <b>Account</b> screen appears where you can view the details of the respective account.</p>

Column Name	Column Description
Person Information	Displays the information about the person.  <b>Note:</b> It has a link. On clicking the link, the <b>Person</b> screen appears where you can view the details of the respective person.
Effective Start Date	If you have selected the <b>Price List</b> option from the <b>Search By</b> list, the date from when the price list is effective appears in this column. However, if you have selected the <b>Assigned Price List</b> option from the <b>Search By</b> list, the date from when the price list is assigned to the account or person appears in this column.
Effective End Date	If you have selected the <b>Price List</b> option from the <b>Search By</b> list, the date till when the price list is effective appears in this column. However, if you have selected the <b>Assigned Price List</b> option from the <b>Search By</b> list, the date till when the price list is assigned to the account or person appears in this column.
Availability Start Date	Displays the date from when the price list is available for assignment to an account or a person.
Availability End Date	Displays the date till when the price list is available for assignment to an account or a person.

### Related Topics

For more information on...	See...
How to assign a price list to an account	<a href="#">Assigning a Price List to an Account</a> on page 418
How to assign a price list to a person	<a href="#">Assigning a Price List to a Person</a> on page 421

### Viewing Price Lists Assigned to an Account

#### Procedure

To view the price lists assigned to an account:

1. Search for the account in the **Customer 360° View** screen.
2. In the **Search Results** section, click the **Show Context Menu** () icon corresponding to the account whose details you want to view.

A menu appears.

3. Click the **Go To Price List Assignment** menu option.

The **Price List Assignment** screen appears. It contains the following zones:

- **Price List Assignments** – Lists the price lists that are already assigned to the account.
- **Price List Price Items** – Lists the price items that are assigned to the price list.
- **Search Price List for Assignment** – Enables you to search for a price list that you want to assign to the account.

4. Do either of the following:

If...	Then
If you want to view the price lists which are currently assigned to an account	<ol style="list-style-type: none"> <li>1. Ensure that the <b>Current Price List Assignments</b> option is selected from the <b>Search By</b> list.</li> </ol>

If...	Then
	<ol style="list-style-type: none"> <li>2. Enter the required search criteria and then click <b>Search</b>. The price lists which are currently assigned to the account appears in the search results.</li> </ol>
If you want to view the price lists assigned to an account which are inactive	<ol style="list-style-type: none"> <li>1. Select the <b>Inactive Price List Assignments</b> option from the <b>Search By</b> list.</li> <li>2. Enter the required search criteria and then click <b>Search</b>. The price lists assigned to an account which are inactive appears in the search results.</li> </ol>
If you want to view the price lists assigned to an account which are expired	<ol style="list-style-type: none"> <li>1. Select the <b>Historical Price List Assignments</b> option from the <b>Search By</b> list.</li> <li>2. Enter the required search criteria and then click <b>Search</b>. The price lists assigned to an account which are expired appears in the search results.</li> </ol>

### Related Topics

For more information on...	See...
How to search for an account	<a href="#">Searching for an Account</a>
<b>Price List Assignment</b> screen	<a href="#">Price List Assignment</a> on page 409
<b>Price List Assignments</b> zone	<a href="#">Price List Assignments</a> on page 409

### Viewing Price Lists Assigned to a Person

#### Procedure

To view the price lists assigned to a person:

1. Search for the person in the **Customer 360° View** screen.
2. In the **Search Results** section, click the **Show Context Menu** () icon corresponding to the person whose details you want to view.

A menu appears.

3. Click the **Go To Price List Assignment** menu option.

The **Price List Assignment** screen appears. It contains the following zones:

- **Price List Assignments** – Lists the price lists that are already assigned to the person.
- **Price List Price Items** – Lists the price items that are assigned to the price list.
- **Search Price List for Assignment** – Enables you to search for a price list that you want to assign to the person.

4. Do either of the following:



If...	Then
If you want to view the price lists which are currently assigned to a person	<ol style="list-style-type: none"> <li>1. Ensure that the <b>Current Price List Assignments</b> option is selected from the <b>Search By</b> list.</li> <li>2. Enter the required search criteria and then click <b>Search</b>.</li> </ol> <p>The price lists which are currently assigned to the person appears in the search results.</p>
If you want to view the price lists assigned to a person which are inactive	<ol style="list-style-type: none"> <li>1. Select the <b>Inactive Price List Assignments</b> option from the <b>Search By</b> list.</li> <li>2. Enter the required search criteria and then click <b>Search</b>.</li> </ol> <p>The price lists assigned to a person which are inactive appears in the search results.</p>
If you want to view the price lists assigned to a person which are expired	<ol style="list-style-type: none"> <li>1. Select the <b>Historical Price List Assignments</b> option from the <b>Search By</b> list.</li> <li>2. Enter the required search criteria and then click <b>Search</b>.</li> </ol> <p>The price lists assigned to a person which are expired appears in the search results.</p>

### Related Topics

For more information on...	See...
How to search for a person	<a href="#">Searching for a Person</a>
<b>Price List Assignment</b> screen	<a href="#">Price List Assignment</a> on page 409
<b>Price List Assignments</b> zone	<a href="#">Price List Assignments</a> on page 409

### **Viewing Price Items Assigned to a Price List**

#### Prerequisites

To view the price items assigned to a price list, you should have:





- An algorithm defined using the **C1-PLPINFO** algorithm type and attached to **Pricelist Products Assignment Information** system event in the **Algorithms** tab of the **Installation Options – Framework** screen

#### Procedure

To view the price items assigned to a price list:

1. Do either of the following:

If you want to view...	Then...
Price items assigned to the price list which is assigned to the account	<ol style="list-style-type: none"> <li>1. Search for the account in the <b>Customer 360° View</b> screen.</li> </ol>

If you want to view...	Then...
	<ol style="list-style-type: none"> <li>2. In the <b>Search Results</b> section, click the <b>Show Context Menu</b> () icon corresponding to the account whose <i>details</i> you want to view. A menu appears.</li> <li>3. Click the <b>Go To Price List Assignment</b> menu option. The <b>Price List Assignment</b> screen appears.</li> <li>4. In the <b>Price List Assignments</b> zone, click the <b>Broadcast</b> () icon corresponding to the assigned price list whose price items you want to view.</li> </ol>
Price items assigned to the price list which is assigned to the person	<ol style="list-style-type: none"> <li>1. Search for the person in the <b>Customer 360° View</b> screen.</li> <li>2. In the <b>Search Results</b> section, click the <b>Show Context Menu</b> () icon corresponding to the person whose <i>details</i> you want to view. A menu appears.</li> <li>3. Click the <b>Go To Price List Assignment</b> menu option. The <b>Price List Assignment</b> screen appears.</li> <li>4. In the <b>Price List Assignments</b> zone, click the <b>Broadcast</b> () icon corresponding to the assigned price list whose price items you want to view.</li> </ol>

The **Price List Price Items** zone appears.

2. View the price items that are assigned to the price list in the **Price List Price Items** zone.

#### **Related Topics**

For more information on...	See...
How to search for an account	<a href="#">Searching for an Account</a>
How to search for a person	<a href="#">Searching for a Person</a>
Price List Assignment screen	<a href="#">Price List Assignment</a> on page 409
Price List Assignments zone	<a href="#">Price List Assignments</a> on page 409
Price List Price Items zone	<a href="#">Price List Price Items</a> on page 411

### **Assigning a Price List to an Account**

#### **Prerequisites**

To assign a price list to an account, you should have:

- Price list defined in the application
- Price list associated with the division to which the account belongs

#### **Procedure**

To assign a price list to an account:

1. Search for the account in the **Customer 360° View** screen.
2. In the **Search Results** section, click the **Show Context Menu** () icon corresponding to the account whose details you want to edit.

A menu appears.

3. Click the **Go To Price List Assignment** menu option.

The **Price List Assignment** screen appears. It contains the following zones:

- **Price List Assignments** – Lists the price lists that are already assigned to the account.
  - **Price List Price Items** – Lists the price items that are assigned to the price list.
  - **Search Price List for Assignment** – Enables you to search for a price list that you want to assign to the account.
4. In the **Search Price List for Assignment** zone, select the **Price List** or **Assigned Price List** option from the **Search By** list depending on whether you want to search against all price lists or against those price lists which are already assigned to an account or a person.
  5. Enter the search criteria in the **Search Price List for Assignment** zone.

**Note:** ORMB search engine supports wildcard search, where you can substitute the percentage (%) symbol as a stand in for any word or letter in a search criteria. You can use the ‘%’ wildcard character in all input fields except the date and ID fields. The ‘%’ wildcard character is suffixed automatically at the end of the partial search criteria. Therefore, you may or may not specify the wildcard character at the end of the partial search criteria. However, you have to prefix the wildcard character manually wherever required.

6. Click **Search**.

A list of price lists that meet the search criteria appears in the **Search Results** section.

**Note:** The search results include only those price lists that are associated with the division to which the account belongs. It may also include price lists that are already assigned to the account in case those price lists match the search criteria.

7. In the **Search Results** section, click the **Assign** () icon corresponding to the price list that you want to assign to the account.

The **Price List Assignment** screen appears. It consists of the following sections:

- **Main** – Used to specify basic information while assigning the price list to the account.
- **Characteristics** – Used to define characteristics for the price list assignment.

The **Main** section contains the following fields:

Field Name	Field Description	Mandatory (Yes or No)
Account Information	Indicates the account to which you want to assign the price list.	Not applicable
Price List Information	Displays the information about the price list.	Not applicable

Field Name	Field Description	Mandatory (Yes or No)										
Effective Start Date	<p>Used to specify the date from when you want to assign the price list to the account.</p> <p><b>Note:</b> The price list assignment start date cannot be earlier than the price list effective start date or later than the price list effective end date.</p>	Yes										
Effective End Date	<p>Used to specify the date till when you want to assign the price list to the account.</p> <p><b>Note:</b></p> <p>The effective end date cannot be earlier than the effective start date.</p> <p>If the validity period is specified for the price list, the price list assignment end date should be earlier than or equal to the following whichever is earlier:</p> <ul style="list-style-type: none"> <li>• Price list assignment validity end date (which is price list assignment start date + validity period)</li> <li>• Price list effective end date</li> </ul> <p>Let us understand this with the help of the following example:</p> <table border="1" data-bbox="516 974 1138 1352"> <tbody> <tr> <td><b>Price List Effective Start Date</b></td> <td>01-Jan-2015</td> </tr> <tr> <td><b>Price List Effective End Date</b></td> <td>31-Jan-2015</td> </tr> <tr> <td><b>Validity Period</b></td> <td>15 Days</td> </tr> <tr> <td><b>Price List Assignment Start Date</b></td> <td>15-Jan-2015</td> </tr> <tr> <td><b>Price List Assignment Validity End Date</b></td> <td>30-Jan-2015 (i.e. 15-Jan-2015 + 15 Days)</td> </tr> </tbody> </table> <p>In the above example, the price list assignment end date must be earlier than or equal to the price list assignment validity end date because the price list assignment validity end date is earlier than the price list effective end date.</p>	<b>Price List Effective Start Date</b>	01-Jan-2015	<b>Price List Effective End Date</b>	31-Jan-2015	<b>Validity Period</b>	15 Days	<b>Price List Assignment Start Date</b>	15-Jan-2015	<b>Price List Assignment Validity End Date</b>	30-Jan-2015 (i.e. 15-Jan-2015 + 15 Days)	No
<b>Price List Effective Start Date</b>	01-Jan-2015											
<b>Price List Effective End Date</b>	31-Jan-2015											
<b>Validity Period</b>	15 Days											
<b>Price List Assignment Start Date</b>	15-Jan-2015											
<b>Price List Assignment Validity End Date</b>	30-Jan-2015 (i.e. 15-Jan-2015 + 15 Days)											
Priority	Used to specify the order in which the price list should be considered while determining the price item pricing for the account.	Yes										
Price List Inheritance	<p>Used to indicate whether the account can avail the price item pricing listed on the parent or grandparent price list if it is not available on the price list. The valid values are:</p> <ul style="list-style-type: none"> <li>• <b>Yes</b> – Used to indicate that the account can inherit the price item pricing from the price list hierarchy.</li> <li>• <b>No</b> – Used to indicate that the account cannot inherit the price item pricing from the price list hierarchy.</li> </ul>	Yes										

Field Name	Field Description	Mandatory (Yes or No)
Assignment Status	Used to indicate the status of the price list assignment. The valid values are: <ul style="list-style-type: none"> <li>• <b>Active</b> – Used to indicate that you want to use the price item pricing on the price list for billing.</li> <li>• <b>Proposed</b> – Used to indicate that you want to use the price item pricing on the price list for quotations.</li> </ul>	Yes

8. Enter the required details in the **Main** section.
9. Define characteristics for the price list assignment, if required.
10. Click **Save**.

The price list is assigned to the account.

### **Related Topics**

For more information on...	See
How to search for an account	<a href="#">Searching for an Account</a>
<b>Price List Assignment</b> screen	<a href="#">Price List Assignment</a> on page 409
<b>Search Price List for Assignment</b> zone	<a href="#">Search Price List for Assignment</a> on page 412
How to define characteristics for a price list assignment	<a href="#">Defining Characteristics for a Price List Assignment</a> on page 424

## **Assigning a Price List to a Person**

### **Prerequisites**

To assign a price list to a person, you should have:

- Price list defined in the application
- Price list associated with the division to which the person belongs

### **Procedure**

To assign a price list to a person:

1. Search for the person in the **Customer 360° View** screen.
2. In the **Search Results** section, click the **Show Context Menu** () icon corresponding to the person whose details you want to edit.

A menu appears.

3. Click the **Go To Price List Assignment** menu option.

The **Price List Assignment** screen appears. It contains the following zones:

- **Price List Assignments** – Lists the price lists that are already assigned to the person.
  - **Price List Price Items** – Lists the price items that are assigned to the price list.
  - **Search Price List for Assignment** – Enables you to search for a price list that you want to assign to the person.
4. In the **Search Price List for Assignment** zone, select the **Price List** or **Assigned Price List** option from the **Search By** list depending on whether you want to search against all price lists or against those price lists which are already assigned to an account or a person.

5. Enter the search criteria in the **Search Price List for Assignment** zone.

**Note:** ORMB search engine supports wildcard search, where you can substitute the percentage (%) symbol as a stand in for any word or letter in a search criteria. You can use the ‘%’ wildcard character in all input fields except the date and ID fields. The ‘%’ wildcard character is suffixed automatically at the end of the partial search criteria. Therefore, you may or may not specify the wildcard character at the end of the partial search criteria. However, you have to prefix the wildcard character manually wherever required.

6. Click **Search**.

A list of price lists that meet the search criteria appears in the **Search Results** section.

**Note:** The search results include only those price lists that are associated with the division to which the person belongs. It may also include price lists that are already assigned to the person in case those price lists match the search criteria.

7. In the **Search Results** section, click the **Assign**  icon corresponding to the price list that you want to assign to the person.

The **Price List Assignment** screen appears. It consists of the following sections:

- **Main** – Used to specify basic information while assigning the price list to the person.
- **Characteristics** – Used to define characteristics for the price list assignment.

The **Main** section contains the following fields:

Field Name	Field Description	Mandatory (Yes or No)
Person Information	Indicates the person to whom you want to assign the price list.	Not applicable
Price List Information	Displays the information about the price list.	Not applicable
Effective Start Date	Used to specify the date from when you want to assign the price list to the person.  <b>Note:</b> The price list assignment start date cannot be earlier than the price list effective start date or later than the price list effective end date.	Yes

Field Name	Field Description	Mandatory (Yes or No)										
Effective End Date	<p>Used to specify the date till when you want to assign the price list to the person.</p> <p><b>Note:</b></p> <p>The effective end date cannot be earlier than the effective start date.</p> <p>If the validity period is specified for the price list, the price list assignment end date should be earlier than or equal to the following whichever is earlier:</p> <ul style="list-style-type: none"> <li>• Price list assignment validity end date (which is price list assignment start date + validity period)</li> <li>• Price list effective end date</li> </ul> <p>Let us understand this with the help of the following example:</p> <table border="1" data-bbox="518 751 1138 1129"> <tr> <td><b>Price List Effective Start Date</b></td> <td>01-Jan-2015</td> </tr> <tr> <td><b>Price List Effective End Date</b></td> <td>31-Jan-2015</td> </tr> <tr> <td><b>Validity Period</b></td> <td>15 Days</td> </tr> <tr> <td><b>Price List Assignment Start Date</b></td> <td>15-Jan-2015</td> </tr> <tr> <td><b>Price List Assignment Validity End Date</b></td> <td>30-Jan-2015 (i.e. 15-Jan-2015 + 15 Days)</td> </tr> </table> <p>In the above example, the price list assignment end date must be earlier than or equal to the price list assignment validity end date because the price list assignment validity end date is earlier than the price list effective end date.</p>	<b>Price List Effective Start Date</b>	01-Jan-2015	<b>Price List Effective End Date</b>	31-Jan-2015	<b>Validity Period</b>	15 Days	<b>Price List Assignment Start Date</b>	15-Jan-2015	<b>Price List Assignment Validity End Date</b>	30-Jan-2015 (i.e. 15-Jan-2015 + 15 Days)	No
<b>Price List Effective Start Date</b>	01-Jan-2015											
<b>Price List Effective End Date</b>	31-Jan-2015											
<b>Validity Period</b>	15 Days											
<b>Price List Assignment Start Date</b>	15-Jan-2015											
<b>Price List Assignment Validity End Date</b>	30-Jan-2015 (i.e. 15-Jan-2015 + 15 Days)											
Priority	Used to specify the order in which the price list should be considered while determining the price item pricing for the person.	Yes										
Price List Inheritance	<p>Used to indicate whether the person can avail the price item pricing listed on the parent or grandparent price list if it is not available on the price list. The valid values are:</p> <ul style="list-style-type: none"> <li>• <b>Yes</b> – Used to indicate that the person can inherit the price item pricing from the price list hierarchy.</li> <li>• <b>No</b> – Used to indicate that the person cannot inherit the price item pricing from the price list hierarchy.</li> </ul>	Yes										

Field Name	Field Description	Mandatory (Yes or No)
Assignment Status	Used to indicate the status of the price list assignment. The valid values are: <ul style="list-style-type: none"> <li>• <b>Active</b> – Used to indicate that you want to use the price item pricing on the price list for billing.</li> <li>• <b>Proposed</b> – Used to indicate that you want to use the price item pricing on the price list for quotations.</li> </ul>	Yes

8. Enter the required details in the **Main** section.
9. Define characteristics for the price list assignment, if required.
10. Click **Save**.

The price list is assigned to the person.

### **Related Topics**

For more information on...	See
How to search for a person	<a href="#">Searching for a Person</a>
<b>Price List Assignment</b> screen	<a href="#">Price List Assignment</a> on page 409
<b>Search Price List for Assignment</b> zone	<a href="#">Search Price List for Assignment</a> on page 412
How to define characteristics for a price list assignment	<a href="#">Defining Characteristics for a Price List Assignment</a>

## **Defining Characteristics for a Price List Assignment**

### **Prerequisites**

To define characteristics for a price list assignment, you should have:

- Characteristic types defined in the application (where the characteristic entity is set to **Price List Assignment**)

### **Procedure**

To define characteristics for a price list assignment:

1. Ensure that the **Characteristics** section is expanded when you are defining or editing characteristics for a price list assignment.

The **Characteristics** section contains the following fields:

Field Name	Field Description	Mandatory (Yes or No)
Effective Date	Used to specify the date from when the characteristic is effective for the price list assignment.	Yes (Conditional) <b>Note:</b> This field is required when you are defining a characteristic for the price list assignment.
Characteristic Type	Used to indicate the characteristic type. <b>Note:</b> The list includes only those characteristic types where the characteristic entity is set to <b>Price List Assignment</b> .	Yes (Conditional) <b>Note:</b> This field is required when you are defining a characteristic for the price list assignment.



Field Name	Field Description	Mandatory (Yes or No)
Characteristic Value	Used to specify the value for the characteristic type.  <b>Note:</b> On specifying the value for a predefined characteristic type, the description of the characteristic value appears corresponding to the <b>Characteristic Value</b> field.	Yes (Conditional)  <b>Note:</b> This field is required when you are defining a characteristic for the price list assignment.

- Enter the required details in the **Characteristics** section.

**Note:** If you select a predefined characteristic type, the **Search** (🔍) icon appears corresponding to the **Characteristic Value** field. On clicking the **Search** icon, you can search for a predefined characteristic value.

- If you want to define more than one characteristic for the price list assignment, click the **Add** (+) icon and then repeat step 2.

**Note:** However, if you want to remove a characteristic from the price list assignment, click the **Delete** (🗑️) icon corresponding to the characteristic.

- Click **Save**.

The characteristics are defined for the price list assignment.

### Related Topics

For more information on...	See...
How to assign a price list to an account	<a href="#">Assigning a Price List to an Account</a> on page 418
How to assign a price list to a person	<a href="#">Assigning a Price List to a Person</a> on page 421
How to edit the price list assignment details of an account	<a href="#">Editing the Price List Assignment Details of an Account</a> on page 425
How to edit the price list assignment details of a person	<a href="#">Editing the Price List Assignment Details of a Person</a> on page 428

### **Editing the Price List Assignment Details of an Account**

#### **Procedure**

To edit the price list assignment details of an account:

- Search for the account in the **Customer 360° View** screen.
- In the **Search Results** section, click the **Show Context Menu** (☰) icon corresponding to the account whose details you want to edit.



A menu appears.

- Click the **Go To Price List Assignment** menu option.

The **Price List Assignment** screen appears. It contains the following zones:

- **Price List Assignments** – Lists the price lists that are already assigned to the account.
- **Price List Price Items** – Lists the price items that are assigned to the price list.
- **Search Price List for Assignment** – Enables you to search for a price list that you want to assign to the account.

## 4. Do either of the following:

If you want to...	Then...
Edit the details of the price list assignment which is currently effective	<ol style="list-style-type: none"> <li data-bbox="846 275 1401 338">1. Select the <b>Current Price List Assignments</b> option from the <b>Search By</b> list.</li> <li data-bbox="846 365 1401 506">2. Enter the required search criteria and then click <b>Search</b>.  The price lists which are currently assigned to the account appears in the search results.</li> <li data-bbox="846 533 1401 674">3. In the <b>Search Results</b> section, click the <b>Edit</b> (  ) icon in the <b>Edit</b> column corresponding to the price list whose assignment details you want to edit.</li> </ol>
Edit the details of the price list assignment which is expired	<ol style="list-style-type: none"> <li data-bbox="846 728 1401 791">1. Select the <b>Historical Price List Assignments</b> option from the <b>Search By</b> list.</li> <li data-bbox="846 819 1401 959">2. Enter the required search criteria and then click <b>Search</b>.  The price lists assigned to an account which are expired appears in the search results.</li> <li data-bbox="846 987 1401 1127">3. In the <b>Search Results</b> section, click the <b>Edit</b> (  ) icon in the <b>Edit</b> column corresponding to the price list whose assignment details you want to edit.</li> </ol>

The **Price List Assignment** screen appears. It contains the following sections:

- **Main** – Used to specify basic information while assigning the price list to the account.
- **Characteristics** – Used to define characteristics for the price list assignment.

The **Main** section contains the following fields:

Field Name	Field Description	Mandatory (Yes or No)
Account Information	Indicates the account whose price list assignment details you want to edit.	Not applicable
Price List Information	Displays the information about the price list.	Not applicable
Effective Start Date	Displays the date from when the price list is assigned to the account.	Not applicable

Field Name	Field Description	Mandatory (Yes or No)										
Effective End Date	<p>Used to specify the date till when you want to assign the price list to the account.</p> <p><b>Note:</b></p> <p>The effective end date cannot be earlier than the effective start date.</p> <p>If the validity period is specified for the price list, the price list assignment end date should be earlier than or equal to the following whichever is earlier:</p> <ul style="list-style-type: none"> <li>• Price list assignment validity end date (which is price list assignment start date + validity period)</li> <li>• Price list effective end date</li> </ul> <p>Let us understand this with the help of the following example:</p> <table border="1" data-bbox="516 751 1140 1129"> <tr> <td><b>Price List Effective Start Date</b></td> <td>01-Jan-2015</td> </tr> <tr> <td><b>Price List Effective End Date</b></td> <td>31-Jan-2015</td> </tr> <tr> <td><b>Validity Period</b></td> <td>15 Days</td> </tr> <tr> <td><b>Price List Assignment Start Date</b></td> <td>15-Jan-2015</td> </tr> <tr> <td><b>Price List Assignment Validity End Date</b></td> <td>30-Jan-2015 (i.e. 15-Jan-2015 + 15 Days)</td> </tr> </table> <p>In the above example, the price list assignment end date must be earlier than or equal to the price list assignment validity end date because the price list assignment validity end date is earlier than the price list effective end date.</p>	<b>Price List Effective Start Date</b>	01-Jan-2015	<b>Price List Effective End Date</b>	31-Jan-2015	<b>Validity Period</b>	15 Days	<b>Price List Assignment Start Date</b>	15-Jan-2015	<b>Price List Assignment Validity End Date</b>	30-Jan-2015 (i.e. 15-Jan-2015 + 15 Days)	No
<b>Price List Effective Start Date</b>	01-Jan-2015											
<b>Price List Effective End Date</b>	31-Jan-2015											
<b>Validity Period</b>	15 Days											
<b>Price List Assignment Start Date</b>	15-Jan-2015											
<b>Price List Assignment Validity End Date</b>	30-Jan-2015 (i.e. 15-Jan-2015 + 15 Days)											
Priority	Used to specify the order in which the price list should be considered while determining the price item pricing for the account.	Yes										
Price List Inheritance	<p>Used to indicate whether the account can avail the price item pricing listed on the parent or grandparent price list if it is not available on the price list. The valid values are:</p> <ul style="list-style-type: none"> <li>• <b>Yes</b> – Used to indicate that the account can inherit the price item pricing from the price list hierarchy.</li> <li>• <b>No</b> – Used to indicate that the account cannot inherit the price item pricing from the price list hierarchy.</li> </ul>	Yes										

Field Name	Field Description	Mandatory (Yes or No)
Assignment Status	<p>Used to indicate the status of the price list assignment. The valid values are:</p> <ul style="list-style-type: none"> <li>• <b>Active</b> – Used to indicate that you want to use the price item pricing on the price list for billing. This value appears only when you are editing an active and proposed price list assignment.</li> <li>• <b>Proposed</b> – Used to indicate that you want to use the price item pricing on the price list for quotations. This value appears only when you are editing a proposed price list assignment.</li> <li>• <b>Rejected</b> – Used to indicate that you want to reject the price list assignment. This value appears only when you are editing a proposed price list assignment.</li> <li>• <b>Inactive</b> – Used to indicate that you no longer want to use the price list assignment. This value appears only when you are editing an active price list assignment.</li> </ul> <p><b>Note:</b> You cannot change the status of a rejected price list assignment.</p>	Yes

5. Modify the required details in the **Main** section.
6. Define, edit, or remove characteristics from the price list assignment, if required.
7. Click **Save**.

The changes made to the price list assignment are saved.

### Related Topics

For more information on...	See
How to search for an account	<a href="#">Searching for an Account</a>
<b>Price List Assignment</b> screen	<a href="#">Price List Assignment</a> on page 409
<b>Price List Assignments</b> zone	<a href="#">Price List Assignments</a> on page 409
How to define characteristics for a price list assignment	<a href="#">Defining Characteristics for a Price List Assignment</a> on page 424

### Editing the Price List Assignment Details of a Person

#### Procedure

To edit the price list assignment details of a person:

1. Search for the person in the **Customer 360° View** screen.
2. In the **Search Results** section, click the **Show Context Menu** () icon corresponding to the person whose details you want to edit.

A menu appears.

3. Click the **Go To Price List Assignment** menu option.

The **Price List Assignment** screen appears. It contains the following zones:

- **Price List Assignments** – Lists the price lists that are already assigned to the person.
- **Price List Price Items** – Lists the price items that are assigned to the price list.
- **Search Price List for Assignment** – Enables you to search for a price list that you want to assign to the person.

4. Do either of the following:

If you want to...	Then...
Edit the details of the price list assignment which is currently effective	<ol style="list-style-type: none"> <li>1. Select the <b>Current Price List Assignments</b> option from the <b>Search By</b> list.</li> <li>2. Enter the required search criteria and then click <b>Search</b>.  The price lists which are currently assigned to the person appears in the search results.</li> <li>3. In the <b>Search Results</b> section, click the <b>Edit</b> (✎) icon in the <b>Edit</b> column corresponding to the price list whose assignment details you want to edit.</li> </ol>
Edit the details of the price list assignment which is expired	<ol style="list-style-type: none"> <li>1. Select the <b>Historical Price List Assignments</b> option from the <b>Search By</b> list.</li> <li>2. Enter the required search criteria and then click <b>Search</b>.  The price lists assigned to a person which are expired appears in the search results.</li> <li>3. In the <b>Search Results</b> section, click the <b>Edit</b> (✎) icon in the <b>Edit</b> column corresponding to the price list whose assignment details you want to edit.</li> </ol>

The **Price List Assignment** screen appears. It contains the following sections:

- **Main** – Used to specify basic information while assigning the price list to the person.
- **Characteristics** – Used to define characteristics for the price list assignment.

The **Main** section contains the following fields:

Field Name	Field Description	Mandatory (Yes or No)
Person Information	Indicates the person whose price list assignment details you want to edit.	Not applicable
Price List Information	Displays the information about the price list.	Not applicable
Effective Start Date	Displays the date from when the price list is assigned to the person.	Not applicable

Field Name	Field Description	Mandatory (Yes or No)										
Effective End Date	<p>Used to specify the date till when the price list is assigned to the person.</p> <p><b>Note:</b></p> <p>The effective end date cannot be earlier than the effective start date.</p> <p>If the validity period is specified for the price list, the price list assignment end date should be earlier than or equal to the following whichever is earlier:</p> <ul style="list-style-type: none"> <li>• Price list assignment validity end date (which is price list assignment start date + validity period)</li> <li>• Price list effective end date</li> </ul> <p>Let us understand this with the help of the following example:</p> <table border="1" data-bbox="521 751 1141 1129"> <tr> <td><b>Price List Effective Start Date</b></td> <td>01-Jan-2015</td> </tr> <tr> <td><b>Price List Effective End Date</b></td> <td>31-Jan-2015</td> </tr> <tr> <td><b>Validity Period</b></td> <td>15 Days</td> </tr> <tr> <td><b>Price List Assignment Start Date</b></td> <td>15-Jan-2015</td> </tr> <tr> <td><b>Price List Assignment Validity End Date</b></td> <td>30-Jan-2015 (i.e. 15-Jan-2015 + 15 Days)</td> </tr> </table> <p>In the above example, the price list assignment end date must be earlier than or equal to the price list assignment validity end date because the price list assignment validity end date is earlier than the price list effective end date.</p>	<b>Price List Effective Start Date</b>	01-Jan-2015	<b>Price List Effective End Date</b>	31-Jan-2015	<b>Validity Period</b>	15 Days	<b>Price List Assignment Start Date</b>	15-Jan-2015	<b>Price List Assignment Validity End Date</b>	30-Jan-2015 (i.e. 15-Jan-2015 + 15 Days)	No
<b>Price List Effective Start Date</b>	01-Jan-2015											
<b>Price List Effective End Date</b>	31-Jan-2015											
<b>Validity Period</b>	15 Days											
<b>Price List Assignment Start Date</b>	15-Jan-2015											
<b>Price List Assignment Validity End Date</b>	30-Jan-2015 (i.e. 15-Jan-2015 + 15 Days)											
Priority	Used to specify the order in which the price list should be considered while determining the price item pricing for the person.	Yes										
Price List Inheritance	<p>Used to indicate whether the person can avail the price item pricing listed on the parent or grandparent price list if it is not available on the price list. The valid values are:</p> <ul style="list-style-type: none"> <li>• <b>Yes</b> – Used to indicate that the person can inherit the price item pricing from the price list hierarchy.</li> <li>• <b>No</b> – Used to indicate that the person cannot inherit the price item pricing from the price list hierarchy.</li> </ul>	Yes										

Field Name	Field Description	Mandatory (Yes or No)
Assignment Status	<p>Used to indicate the status of the price list assignment. The valid values are:</p> <ul style="list-style-type: none"> <li>• <b>Active</b> – Used to indicate that you want to use the price item pricing on the price list for billing. This value appears only when you are editing an active and proposed price list assignment.</li> <li>• <b>Proposed</b> – Used to indicate that you want to use the price item pricing on the price list for quotations. This value appears only when you are editing a proposed price list assignment.</li> <li>• <b>Rejected</b> – Used to indicate that you want to reject the price list assignment. This value appears only when you are editing a proposed price list assignment.</li> <li>• <b>Inactive</b> – Used to indicate that you no longer want to use the price list assignment. This value appears only when you are editing an active price list assignment.</li> </ul> <p><b>Note:</b> You cannot change the status of a rejected price list assignment.</p>	Yes

5. Modify the required details in the **Main** section.
6. Define, edit, or remove characteristics from the price list assignment, if required.
7. Click **Save**.

The changes made to the price list assignment are saved.

### Related Topics

For more information on...	See
How to search for a person	<a href="#">Searching for a Person</a>
<b>Price List Assignment</b> screen	<a href="#">Price List Assignment</a> on page 409
<b>Price List Assignments</b> zone	<a href="#">Price List Assignments</a> on page 409
How to define characteristics for a price list assignment	<a href="#">Defining Characteristics for a Price List Assignment</a>

## Price List Assignments

The **Price List Assignments** screen allows you to view the price list assignments of a particular price list. It contains the following zones:

- [Persons to whom Price List is Assigned](#) on page 432
- [Accounts where Price List is Assigned](#) on page 431

### Accounts where Price List is Assigned

The **Accounts where Price List is Assigned** zone displays the details of the accounts where price list is assigned. It contains the following fields:

Field Name	Field Description
Account ID	Displays the account ID.
Account Information	Displays information about the account. In addition, this column has a context menu which helps in navigating to other screens in the application.  <b>Note:</b> It has a link. On clicking the link, the <b>Account</b> screen appears where you can view the details of the respective account.
Price List Assignment Start Date	Displays the price list assignment start date.
Price List Assignment End Date	Displays the price list assignment end date.
Division	Displays the division to which the account belongs.
Price List Assignment ID	Displays the price list assignment ID.

### Related Topics

For more information on...	See...
How to search a price list	<a href="#">Searching for a Price List</a> on page 371
How to view accounts and persons where price list is assigned	<a href="#">Viewing Accounts and Persons where Price List is Assigned</a> on page 433

### Persons to whom Price List is Assigned

The **Persons to whom Price List is Assigned** zone displays the details of the persons where price list is assigned. It contains the following fields:

Field Name	Field Description
Person ID	Displays the person ID.
Person Information	Displays information about the person. In addition, this column has a context menu which helps in navigating to other screens in the application.  <b>Note:</b> It has a link. On clicking the link, the <b>Person</b> screen appears where you can view the details of the respective person.
Price List Assignment Start Date	Displays the price list assignment start date.
Price List Assignment End Date	Displays the price list assignment end date.
Division	Displays the division to which the person belongs.
Price List Assignment ID	Displays the price list assignment ID.

### Related Topics

For more information on...	See...
How to search a price list	<a href="#">Searching for a Price List</a> on page 371



For more information on...	See...
How to view accounts and persons where price list is assigned	<a href="#">Viewing Accounts and Persons where Price List is Assigned</a> on page 433

## Viewing Accounts and Persons where Price List is Assigned

### Prerequisites

To view accounts and persons where price list is assigned, you should have:

- Accounts and persons created in the application
- Price list defined and assigned to the accounts and persons

### Procedure

To view accounts and persons where price list is assigned:

1. Click the **Menu** link in the **Application** toolbar.  
A list appears.
2. From the **Main** menu, select **Pricing Management** and then click **Price List**.  
The **Price List** screen appears.
3. You can search for a price list by entering the search criteria in the **Search Price List** zone.

**Note:** ORMB search engine supports wildcard search, where you can substitute the percentage (%) symbol as a stand in for any word or letter in a search criteria. You can use the ‘%’ wildcard character in all input fields except the date and ID fields. The ‘%’ wildcard character is suffixed automatically at the end of the partial search criteria. Therefore, you may or may not specify the wildcard character at the end of the partial search criteria. However, you have to prefix the wildcard character manually wherever required.

4. Click **Search**.  
A list of price lists that meet the search criteria appears in the search results.
5. In the **Search Results** section, click the **Assigned To** (🔗) icon in the **Assigned To** column corresponding to the price list whose details you want to view.  
The **Price List Assignments** screen appears.
6. You can view the accounts and persons list where price list is assigned in the **Price List Assignments** screen.

### Related Topics

For more information on...	See...
How to search a price list	<a href="#">Searching for a Price List</a> on page 371
<b>Accounts where Price List is Assigned</b> zone	<a href="#">Accounts where Price List is Assigned</a> on page 431
<b>Persons to whom Price List is Assigned</b> zone	<a href="#">Persons to whom Price List is Assigned</a> on page 432

## Persons and Accounts Eligible for Price List Assignment

The **Persons and Accounts Eligible for Price List Assignment** screen allows you to view the details of a price list. It also allows you to search for multiple eligible accounts or persons and assign them to the price list. This screen consists of the following zones:

- [Eligible Accounts](#) on page 434
- [Eligible Persons](#) on page 434

## Eligible Accounts

The **Eligible Accounts** zone allows you to search the eligible accounts for price list assignments. Moreover, it also allows you to assign the multiple eligible accounts to a price list. This zone contains the following two sections:

- **Search Criteria** — The **Search Criteria** section contains the following fields:

Field Name	Field Description	Mandatory (Yes or No)
Division	Used to indicate the division whose accounts you want to search.	Yes
Effective Date	Used to indicate the date from when the accounts are eligible for price list assignment.	No
Account ID	Used to indicate the account ID.	No

- **Search Results** — On clicking the **Search** button, the search results appear based on the specified search criteria. The **Search Results** section contains the following columns:

Column Name	Column Description
Account Information	<p>Displays the information about the eligible accounts where price list can be assigned. In addition, this column has a context menu which helps in navigating to other screens in the application.</p> <div style="border: 1px solid black; padding: 5px; margin-top: 10px;"> <p><b>Note:</b> It has a link. On clicking the link, the <b>Account</b> screen appears where you can view the details of the respective account.</p> </div>
Assigned	<p>Displays whether the account is assigned to the price list or not. The valid values are:</p> <ul style="list-style-type: none"> <li>• Yes</li> <li>• No</li> </ul>

## Eligible Persons

The **Eligible Persons** zone allows you to search the eligible persons for price list assignments. Moreover, it also allows you to assign the multiple eligible persons to a price list. This zone contains the following two sections:

- **Search Criteria** — The **Search Criteria** section contains the following fields:

Field Name	Field Description	Mandatory (Yes or No)
Division	Used to indicate the division whose persons you want to search.	Yes
Effective Date	Used to indicate the date from when the persons are eligible for price list assignment.	No
Person ID	Used to indicate the person ID.	No

- **Search Results** — On clicking the **Search** button, the search results appear based on the specified search criteria. The **Search Results** section contains the following columns:

Column Name	Column Description
Person Information	<p>Displays the information about the eligible persons where price list can be assigned. In addition, this column has a context menu which helps in navigating to other screens in the application.</p> <p><b>Note:</b> It has a link. On clicking the link, the <b>Person</b> screen appears where you can view the details of the respective person.</p>
Assigned	<p>Displays whether the person is assigned to the price list or not. The valid values are:</p> <ul style="list-style-type: none"> <li>• Yes</li> <li>• No</li> </ul>

### **Related Topics**

For more information on...	See...
How to search for a price list	<a href="#">Searching for a Price List</a> on page 371
How to view the accounts and persons eligible for price list assignments	<a href="#">Viewing Accounts and Persons Eligible for Price List Assignment</a>
How to define characteristics for a Price List Assignment	<a href="#">Defining Characteristics for a Price List Assignment</a> on page 438

## **Assigning a Price List to One or More Eligible Accounts**

### **Prerequisites**

To assign a price list to one or more eligible accounts, you should have:

- Price list defined in the application
- Accounts created in the application
- Price list should be associated with the division to which accounts belong.

### **Procedure**

To assign a price list to one or more eligible accounts:

1. Search for the eligible accounts in the **Eligible Accounts** zone of **Persons and Accounts Eligible for Price List Assignment** screen.
2. In the **Search Results** section, select the one or more accounts that you want to assign to the price list.
3. Click the **Assign** button available in the upper left corner of this section

The **Price List Assignment** screen appears. This screen contains following two sections:

- **Main** — Used to specify basic details about the price list. This section contains the following fields:

Field Name	Field Description	Mandatory (Yes or No)
Price List Information	Displays the additional information about the price list.	Not applicable
Effective Start Date	Used to specify the date from when the price list is effective.	Yes
Effective End Date	Used to specify the date till when the price list is effective.	No

Field Name	Field Description	Mandatory (Yes or No)
Priority	Used to specify the order in which the price list should be considered while determining the price item pricing for the account.	No
Price List Inheritance	Used to indicate whether the account can avail the price item pricing listed on the parent or grandparent price list if it is not available on the price list. The valid values are: <ul style="list-style-type: none"> <li>• Yes</li> <li>• No</li> </ul>	No
Assignment Status	Used to indicate the status of the price list assignment. The valid values are: <ul style="list-style-type: none"> <li>• Active</li> <li>• Proposed</li> </ul>	No
Priority Indicator	Used to set the priority of the price list assignment. The valid values are: <ul style="list-style-type: none"> <li>• <b>Highest</b> — Used when you want the price list assignment to have the highest priority. It checks whether there are any other price list assignments for the account, derives the priority of each such price list assignment, and then sets the priority of the new price list assignment to the existing price list assignment with highest priority minus one.</li> <li>• <b>Lowest</b> — Used when you want the price list assignment to have the lowest priority. It checks whether there are any other price list assignments for the account, derives the priority of each such price list assignment, and then sets the priority of the new price list assignment to the existing price list assignment with lowest priority plus one.</li> </ul>	No

- **Characteristics** — Used to define characteristics for the price list.

#### 4. Click **Save**.

Selected accounts are assigned to the price list.

#### **Related Topics**

For more information on...	See...
How to search for a price list	<a href="#">Searching for a Price List</a> on page 371
<b>Eligible Persons</b> zone	<a href="#">Eligible Persons</a> on page 434
<b>Eligible Accounts</b> zone	<a href="#">Eligible Accounts</a> on page 434
How to define characteristics for a Price List Assignment	<a href="#">Defining Characteristics for a Price List Assignment</a> on page 438

## Assigning a Price List to One or More Eligible Persons

### Prerequisites

To assign a price list to one or more eligible persons, you should have:

- Price list defined in the application
- Persons created in the application
- Price list should be associated with the division to which persons belong.

### Procedure

To assign a price list to one or more eligible persons:

1. Search for the eligible Persons in the **Eligible Persons** zone of **Persons and Accounts Eligible for Price List Assignment** screen.
2. In the **Search Results** section, select the one or more persons that you want to assign to the price list.
3. Click the **Assign** button available in the upper left corner.

The **Price List Assignment** screen appears. This screen contains following two sections:

- **Main** — Used to specify basic details about the price list. This section contains the following fields:

Field Name	Field Description	Mandatory (Yes or No)
Price List Information	Displays the additional information about the price list.	Not applicable
Effective Start Date	Used to specify the date from when the price list is effective.	Yes
Effective End Date	Used to specify the date till when the price list is effective.	No
Priority	Used to specify the order in which the price list should be considered while determining the price item pricing for the person.	No
Price List Inheritance	Used to indicate whether the account can avail the price item pricing listed on the parent or grandparent price list if it is not available on the price list. The valid values are: <ul style="list-style-type: none"> <li>• Yes</li> <li>• No</li> </ul>	No
Assignment Status	Used to indicate the status of the price list assignment. The valid values are: <ul style="list-style-type: none"> <li>• Active</li> <li>• Proposed</li> </ul>	No

Field Name	Field Description	Mandatory (Yes or No)
Priority Indicator	Used to set the priority of the price list assignment. The valid values are: <ul style="list-style-type: none"> <li>• <b>Highest</b> — Used when you want the price list assignment to have the highest priority. It checks whether there are any other price list assignments for the person, derives the priority of each such price list assignment, and then sets the priority of the new price list assignment to the existing price list assignment with highest priority minus one.</li> <li>• <b>Lowest</b> — Used when you want the price list assignment to have the lowest priority. It checks whether there are any other price list assignments for the person, derives the priority of each such price list assignment, and then sets the priority of the new price list assignment to the existing price list assignment with lowest priority plus one.</li> </ul>	No

- **Characteristics** — Used to define characteristics for the price list.

#### 4. Click **Save**.

Selected persons are assigned to the price list.

#### **Related Topics**

For more information on...	See...
How to search for a price list	<a href="#">Searching for a Price List</a> on page 371
<b>Eligible Persons</b> zone	<a href="#">Eligible Persons</a> on page 434
<b>Eligible Accounts</b> zone	<a href="#">Eligible Accounts</a> on page 434
How to define characteristics for a Price List Assignment	<a href="#">Defining Characteristics for a Price List Assignment</a> on page 438

## Defining Characteristics for a Price List Assignment

### **Prerequisites**

To define characteristics for a price list assignment, you should have:

- Characteristic types defined in the application (where the characteristic entity is set to **Price List Assignment**)

### **Procedure**

To define characteristics for a price list assignment:

1. Click the **Characteristics** tab in the **Price List Assignment** screen when you are assigning a price list to multiple persons or accounts and also editing the price list assignment details of multiple persons or accounts.

The **Characteristics** tab appears. It contains the following fields:

Field Name	Field Description	Mandatory (Yes or No)
Effective Date	Used to specify the date from when the characteristic is effective for the price list assignment.	Yes (Conditional) <b>Note:</b> This field is required when you are defining a characteristic for the price list assignment.
Characteristic Type	Used to indicate the characteristic type. <b>Note:</b> The list includes only those characteristic types where the characteristic entity is set to <b>Price List Assignment</b> .	Yes (Conditional) <b>Note:</b> This field is required when you are defining a characteristic for the price list assignment.
Characteristic Value	Used to specify the value for the characteristic type. <b>Note:</b> On specifying the value for a predefined characteristic type, the description of the characteristic value appears corresponding to the <b>Characteristic Value</b> field.	Yes (Conditional) <b>Note:</b> This field is required when you are defining a characteristic for the price list assignment.

- Enter the required details in the **Characteristics** tab.

**Note:** If you select a predefined characteristic type, the **Search** (🔍) icon appears corresponding to the **Characteristic Value** field. On clicking the **Search** icon, you can search for a predefined characteristic value.

- If you want to define more than one characteristic for the price list assignment, click the **Add** (+) icon and then repeat step 2.

**Note:** However, if you want to remove a characteristic from the price list assignment, click the **Delete** (🗑️) icon corresponding to the characteristic.

- Click **Save**.

The characteristics are defined for the price list assignment.

### Related Topics

For more information on...	See...
How to assign a price list to a person	<a href="#">Assigning a Price List to a Person</a> on page 421
How to edit the price list assignment details of a person	<a href="#">Editing the Price List Assignment Details of a Person</a> on page 428

## Pricing (Account)

The **Pricing (Account)** screen allows you to:

- View effective price assignments of an account
- View the details of an assigned or inherited price item pricing
- Search and assign price items or price item bundles to an account

- Edit or override a price item pricing
- Copy a price item pricing and assign it to an account

This screen consists of the following zones:

- [Effective Price Assignments for Account](#) on page 440
- [Search Price Item](#) on page 445

## Effective Price Assignments for Account

The **Effective Price Assignments for Account** zone lists the price item pricing (i.e. price assignments) which are effective on the current date. In other words, it lists effective pricing for price items or price item bundles assigned to the account either directly or through the customer hierarchy. The order in which the price assignments are listed is controlled by the **Price Assignment Search** algorithm defined for the division to which the account belongs. If required, you can filter effective price assignments using various search criteria.

**Note:** If the effective pricing is available for the price item, regular bundle (to which the price item belongs), and parent (regular) bundle (i.e. to which the regular bundle belongs) at the same level, the system lists the pricing depending on the value defined for the **Prefer Price Item Over Bundle** parameter in the price assignment search algorithm. If the value of the **Prefer Price Item Over Bundle** parameter is set to **Y**, the system lists effective pricing which is available for the price item. If the effective pricing is not available for the price item, then the system lists effective pricing which is available for the regular bundle at the same level. If the effective pricing is not available for the regular bundle, then the system lists effective pricing which is available for the parent bundle at the same level. However, if the value of the **Prefer Price Item Over Bundle** parameter is set to **N**, the system lists effective pricing which is available for the parent bundle. If the effective pricing is not available for the parent bundle, then the system lists effective pricing which is available for the regular bundle at the same level. If the effective pricing is not available for the regular bundle, then the system lists effective pricing which is available for the price item at the same level.

This zone contains the following two sections:

- **Search Criteria** – The **Search Criteria** section contains the following fields:

Field Name	Field Description	Mandatory (Yes or No)
Account ID	Indicates the account whose effective price assignments are listed in this zone.	Not applicable
Effective Pricing Date	Used to search price assignments which are effective on a particular date.  <b>Note:</b> By default, this field is set to the system date.	No



Field Name	Field Description	Mandatory (Yes or No)
Assignment Level	<p>Used to search price assignments at a particular level in the customer hierarchy. The valid values are:</p> <ul style="list-style-type: none"> <li>• <b>Account Agreed</b> – Means price item pricing is agreed for the account.</li> <li>• <b>Account Price List</b> – Means price item pricing is defined in the price list which is assigned to the account.</li> <li>• <b>Account Inherited Price List</b> – Means price item pricing is inherited from the parent price list hierarchy defined for the price list which is assigned to the account.</li> <li>• <b>Customer Agreed</b> – Means price item pricing is agreed for the main customer in the customer hierarchy.</li> <li>• <b>Customer Price List</b> – Means price item pricing is defined in the price list which is assigned to the main customer.</li> <li>• <b>Default Price List</b> – Means price item pricing defined in the price list is available in the default price list.</li> <li>• <b>Global Price List</b> – Means price item pricing defined in the price list is available in the global price list.</li> <li>• <b>Customer Inherited Price List</b> – Means price item pricing is inherited from the parent price list hierarchy defined for the price list which is assigned to the main customer.</li> <li>• <b>Parent Customer Agreed</b> – Means price item pricing is agreed for the parent customer in the customer hierarchy.</li> <li>• <b>Parent Customer Price List</b> – Means price item pricing is defined in the price list which is assigned to the parent customer.</li> <li>• <b>Parent Customer Inherited Price List</b> – Means price item pricing is inherited from the parent price list hierarchy defined for the price list which is assigned to the parent customer.</li> <li>• <b>Product Default Price List</b> – Means product defined in the price list is available in the default price list.</li> </ul>	No
Parent Person	Used to search price assignments which are inherited from a particular parent customer.	No

Field Name	Field Description	Mandatory (Yes or No)
Pricing Status	Used to search price assignments with a particular status. The valid values are: <ul style="list-style-type: none"> <li>Active</li> <li>Proposed</li> </ul> <div style="border: 1px solid black; padding: 2px;"><b>Note:</b> By default, the <b>Active</b> option is selected.</div>	No
Show Default and Global Pricing	Used to search price assignments inherited from the default or global price list. The valid values are: <ul style="list-style-type: none"> <li><b>Yes</b> – Used when you want to search price assignments inherited from either of the following: <ul style="list-style-type: none"> <li>Product-specific default price list defined for the division</li> <li>Default price list defined for the division</li> <li>Global price list</li> </ul> </li> <li><b>No</b> – Used when you do not want to search price assignments inherited from either of the following: <ul style="list-style-type: none"> <li>Product-specific default price list defined for the division</li> <li>Default price list defined for the division</li> <li>Global price list</li> </ul> </li> </ul> <div style="border: 1px solid black; padding: 2px;"><b>Note:</b> By default, the <b>No</b> option is selected.</div>	No
Price Item	Used to search price assignments of a particular price item or price item bundle.	No
Description	Used to search price assignments of a price item or price item bundle having a particular description.	No
Search Type	Used to search the price list using the following values: <ul style="list-style-type: none"> <li>Best Fit</li> <li>Exact Match</li> </ul> <div style="border: 1px solid black; padding: 2px;"><b>Note:</b> By default, the <b>Exact Match</b> option is selected.</div>	No

**Note:** The **Search**  icon appears corresponding to the **Price Item** field. On clicking the **Search** icon, you can search for a price item.

- Price Item Parameters** – The **Price Item Parameters** section contains the following fields:

Field Name	Field Description	Mandatory (Yes or No)
Parameter	Used to search price assignments which are defined using a particular parameter.  <b>Note:</b> This field appears only when the <b>Multi Price Parameter</b> option type of the <b>Multi Parameter Based Pricing (C1_PPARM_FLG)</b> feature configuration is set to <b>True</b> .	No
Parameter Value	Used to search price assignments which are defined using a particular parameter value.  <b>Note:</b> This field appears only when the <b>Multi Price Parameter</b> option type of the <b>Multi Parameter Based Pricing (C1_PPARM_FLG)</b> feature configuration is set to <b>True</b> .	No

**Note:**

The **Search**  icon appears corresponding to the **Parameter** field. On clicking the **Search** icon, you can search for a parameter.

You can only use those parameters where the source entity is set to **Transaction**.

The **Search**  icon appears corresponding to the **Parameter Value** field only when the value type of the parameter is **Predefined** or **Reference**. If the value type of the parameter is **Predefined** then on clicking the **Search** icon, you can search for a predefined parameter value. However, if the value type of the parameter is **Reference** then on clicking the **Search** icon, you can search for a reference parameter value.

- **Search Results** – On clicking the **Search** button, the search results are filtered based on the specified search criteria. The **Search Results** section contains the following columns:

Column Name	Column Description
Pricing Information	Displays the concatenated string consisting of pricing information and pricing ID for the account.  <b>Note:</b> It has a link. On clicking the link, the <b>View Price Item Pricing</b> screen appears with the details of the respective price item pricing.
Price Item	Displays the price item or price item bundle code.
Pricing Parameters	Used to specify multiple parameters based on which you want to determine the pricing utilization.  <b>Note:</b> This column appears only when the <b>Multi Price Parameter</b> option type of the <b>Multi Parameter Based Pricing (C1_PPARM_FLG)</b> feature configuration is set to <b>True</b> .

Column Name	Column Description
Price Assignment Type	Indicates the type of price assignment. The valid values are: <ul style="list-style-type: none"> <li>• Regular</li> <li>• Post Processing</li> <li>• Post Processing – Invoice Based</li> <li>• Post Processing – Price Item Based</li> </ul>
Assignment Level	Indicates the level at which the price item pricing is defined in the customer hierarchy. The valid values are: <ul style="list-style-type: none"> <li>• Account Agreed</li> <li>• Account Price List</li> <li>• Account Inherited Price List</li> <li>• Customer Agreed</li> <li>• Customer Price List</li> <li>• Default Price List</li> <li>• Global Price List</li> <li>• Customer Inherited Price List</li> <li>• Parent Customer Agreed</li> <li>• Parent Customer Price List</li> <li>• Parent Customer Inherited Price List</li> <li>• Product Default Price List</li> </ul>
Price List Information	Displays the information about the price list which is assigned to the account.
Rate Schedule	Indicates the rate schedule which is used for defining the price item pricing.
Edit	On clicking the <b>Edit</b> (  ) icon, the <b>Price Item Pricing</b> screen appears where you can edit the details of the price item pricing. <div style="border: 1px solid black; padding: 5px; margin-top: 10px;"> <p><b>Note:</b> The <b>Edit</b> icon appears only when the assignment level is <b>Account Agreed</b>.</p> </div>

Column Name	Column Description
Override	<p>On clicking the <b>Override</b>  icon, the <b>Price Item Pricing</b> screen appears where you can override the price item pricing.</p> <div style="border: 1px solid black; padding: 5px;"> <p><b>Note:</b></p> <p>You can override a price item pricing assigned at any level in the customer hierarchy. On overriding a price item pricing, a new price item pricing which is specific to the account is defined at the account level and is then called account agreed pricing.</p> <p>A customer agreed or account agreed price assignments are effective for a particular duration and do not expire until you specify the end date manually. However, if you set the <b>Expire Override Switch</b> option type of the <b>C1_EXP_OVRD</b> feature configuration to <b>Y</b>, the system will automatically expire an agreed pricing when the agreed pricing of a customer or an account without end date is overridden. If you do not want an agreed pricing to automatically expire when it is overridden, you must set the <b>Expire Override Switch</b> option type of the <b>C1_EXP_OVRD</b> feature configuration to <b>N</b>.</p> </div>
Effective Start Date	Displays the date from when the price item pricing is effective.
Effective End Date	Displays the date till when the price item pricing is effective.
Pricing Currency	Indicates the currency in which the price item pricing is defined.
Parent Person	Displays the name of the parent or grandparent customer from whom the price item pricing is inherited.

**Note:** The number of records that can be displayed in the **Search Results** section is controlled via the **C1\_PR\_REC** feature configuration. You can change the number of records that can be displayed using the **Effective Pricing RecordSet Limit** option type of the **C1\_PR\_REC** feature configuration. For more information, refer to [Setting the C1\\_PR\\_REC Feature Configuration](#) on page 2924.

### Related Topics

For more information on...	See...
How to view effective price assignments of an account	<a href="#">Viewing Effective Price Assignments of an Account</a> on page 450
How to override a price item pricing	<a href="#">Overriding a Price Item Pricing</a> on page 569
How to edit a price item pricing	<a href="#">Editing a Price Item Pricing</a>
How to filter effective price assignments of an account	<a href="#">Filtering Effective Price Assignments of an Account</a> on page 451

### Search Price Item

You can either assign a price item to a price list and then define pricing for the price item, or you can copy an existing price item pricing and assign it to a price list. The **Search Price Item** zone allows you to search for a price item pricing which is assigned to an account, person, or a price list. You can then create a new price item pricing using an existing price item pricing through copying the price item pricing. Once you create a copy of an existing price item pricing, the new price item pricing is assigned to the price list. On copying a price item pricing, the pricing details including the price components, eligibility and tiering criteria for each price component, and characteristics are copied to the new price item pricing. You can then edit the details, if required.

The system allows you to create a copy of active, proposed, inactive, rejected, and template price item pricing. Once you create the copy of a template price item pricing, you can save the new price item pricing in either **Active** or **Proposed** status.

The **Search Price Item** zone contains the following two sections:

- **Search Criteria** – The **Search Criteria** section contains the following fields:

Field Name	Field Description	Mandatory (Yes or No)
Search By	Used to search whether you want to search price item pricing for a price item, account, person, or a price list. The valid values are: <ul style="list-style-type: none"> <li>• Price Item</li> <li>• Price List Pricing</li> <li>• Account Override Pricing</li> <li>• Person Override Pricing</li> </ul>	Yes
Price Item	Used to search pricing for a particular price item or price item bundle.	No
Description	Used to search price items or price item bundles with a particular description. <p><b>Note:</b> This field appears only when you select the <b>Price Item</b> option from the <b>Search By</b> list.</p>	No
Global Price List	Used to search price items or price item bundles which can be assigned to a global price list. The valid values are: <ul style="list-style-type: none"> <li>• Yes</li> <li>• No</li> </ul> <p><b>Note:</b> This field appears only when you select the <b>Price Item</b> option from the <b>Search By</b> list.</p>	No
Bundle	Used to search whether the price item is a bundle or not. The valid values are: <ul style="list-style-type: none"> <li>• Yes</li> <li>• No</li> </ul> <p><b>Note:</b> This field appears only when you select the <b>Price Item</b> option from the <b>Search By</b> list.</p>	No
Price List ID	Used to search the price list to which the price item pricing is assigned. <p><b>Note:</b> This field appears only when you select the <b>Price List Pricing</b> option from the <b>Search By</b> list.</p>	No

Field Name	Field Description	Mandatory (Yes or No)
Effective Start Date	<p>Used to search price item pricing on price lists which are effective from a particular date onwards.</p> <p><b>Note:</b> This field appears only when you select the <b>Price List Pricing, Account Override Pricing, or Person Override Pricing</b> option from the <b>Search By</b> list.</p>	No
Effective End Date	<p>Used to search price item pricing on price lists which are effective till a particular date.</p> <p><b>Note:</b> This field appears only when you select the <b>Price List Pricing, Account Override Pricing, or Person Override Pricing</b> option from the <b>Search By</b> list.</p>	No
Pricing Status	<p>Used to search price item pricing with a particular status. The valid values are:</p> <ul style="list-style-type: none"> <li>• Active</li> <li>• Inactive</li> <li>• Proposed</li> <li>• Rejected</li> <li>• Template</li> </ul> <p><b>Note:</b> This field appears only when you select the <b>Price List Pricing, Account Override Pricing, or Person Override Pricing</b> option from the <b>Search By</b> list.</p>	No
Price Assignment Type	<p>Used to search a particular type of the price item pricing. The valid values are:</p> <ul style="list-style-type: none"> <li>• Regular</li> <li>• Post Processing</li> <li>• Post Processing – Invoice Based</li> <li>• Post Processing – Price Item Based</li> </ul> <p><b>Note:</b> This field appears only when you select the <b>Price List Pricing, Account Override Pricing, or Person Override Pricing</b> option from the <b>Search By</b> list.</p>	No
Account ID	<p>Used to search pricing of price items which are assigned to a particular account.</p> <p><b>Note:</b> This field appears only when you select the <b>Account Override Pricing</b> option from the <b>Search By</b> list.</p>	No

Field Name	Field Description	Mandatory (Yes or No)
Person ID	Used to search pricing of price items which are assigned to a particular person.  <b>Note:</b> This field appears only when you select the <b>Person Override Pricing</b> option from the <b>Search By</b> list.	No



**Note:**

You must specify at least one search criterion while searching for a price item or price item bundle.

The **Search**  icon appears corresponding to the **Price List ID**, **Price Item**, **Account ID**, and **Person ID** fields. On clicking the **Search** icon, you can search for a price list, price item, an account, and person.

- **Search Results** – On clicking the **Search** button, the search results appear based on the specified search criteria. The search results include only those price items or price item bundles that are associated with the division to which the account belongs. It may also include price items or price item bundles that are already assigned to the account in case those price items or price item bundles match the search criteria.

The **Search Results** section contains the following columns:

Column Name	Column Description
Assign	On clicking the <b>Assign</b>  icon, the <b>Price Item Pricing</b> screen appears where you can define a new price item pricing.  <b>Note:</b> This column appears only when you select the <b>Price Item</b> option from the <b>Search By</b> list.
Price Item Information	Displays details of the price item or price item bundle.  <b>Note:</b> It has a link. On clicking the link, the <b>Price Item</b> screen appears where you can view the details of the respective price item or price item bundle.  This column appears only when you select the <b>Price Item</b> option from the <b>Search By</b> list.
Copy	On clicking the <b>Copy</b>  icon, the <b>Price Item Pricing</b> screen appears where you can define a new price item pricing using an existing price item pricing.
Pricing Information	Displays details of the price item pricing.  <b>Note:</b> This column appears only when you select the <b>Price List Pricing</b> , <b>Account Override Pricing</b> , or <b>Person Override Pricing</b> option from the <b>Search By</b> list.



Column Name	Column Description
Account Information	<p>Indicates the account to which the price item pricing is assigned. In addition, this column has a context menu which helps in navigating to other screens in the application.</p> <div data-bbox="570 321 1466 659" style="border: 1px solid black; padding: 5px;"> <p><b>Note:</b></p> <p>This column appears only when you select the <b>Account Override Pricing</b> option from the <b>Search By</b> list.</p> <p>It has a link. On clicking the link, the <b>Account</b> screen appears where you can view the details of the respective account.</p> <p>The account information string appears only when an algorithm defined using the <b>C1-AC-INFO</b> algorithm type is attached to the <b>Account Information</b> system event in the <b>Algorithms</b> tab of the <b>Installation Options – Framework</b> screen.</p> </div>
Person Information	<p>Indicates the person to which the price item pricing is assigned. In addition, this column has a context menu which helps in navigating to other screens in the application.</p> <div data-bbox="570 800 1466 1138" style="border: 1px solid black; padding: 5px;"> <p><b>Note:</b></p> <p>This column appears only when you select the <b>Person Override Pricing</b> option from the <b>Search By</b> list.</p> <p>It has a link. On clicking the link, the <b>Person</b> screen appears where you can view the details of the respective person.</p> <p>The person information string appears only when an algorithm defined using the <b>PERS-INFO</b> algorithm type is attached to the <b>Person Information</b> system event in the <b>Algorithms</b> tab of the <b>Installation Options – Framework</b> screen.</p> </div>
Price List Information	<p>Indicates the price list to which the price item pricing is assigned. In addition, this column has a context menu which helps in navigating to other screens in the application.</p> <div data-bbox="570 1276 1466 1499" style="border: 1px solid black; padding: 5px;"> <p><b>Note:</b></p> <p>This column appears only when you select the <b>Price List Pricing</b> option from the <b>Search By</b> list.</p> <p>It has a link. On clicking the link, the <b>Price List</b> screen appears where you can view the details of the respective price list.</p> </div>
Pricing Parameters	<p>Displays a comma-separated list of parameter values. The order in which parameter values appear in this column is controlled by the display order (which is defined while associating a parameter with a price item or price item bundle).</p> <div data-bbox="570 1644 1466 1755" style="border: 1px solid black; padding: 5px;"> <p><b>Note:</b> This column appears only when the <b>Multi Price Parameter</b> option type of the <b>Multi Parameter Based Pricing (C1_PPARM_FLG)</b> feature configuration is set to <b>False</b>.</p> </div>
Effective Start Date	<p>Displays the date from when the price item pricing is effective.</p> <div data-bbox="570 1833 1466 1913" style="border: 1px solid black; padding: 5px;"> <p><b>Note:</b> This column appears only when you select the <b>Price List Pricing</b>, <b>Account Override Pricing</b>, or <b>Person Override Pricing</b> option from the <b>Search By</b> list.</p> </div>

Column Name	Column Description
Effective End Date	<p>Displays the date till when the price item pricing is effective.</p> <p><b>Note:</b> This column appears only when you select the <b>Price List Pricing, Account Override Pricing, or Person Override Pricing</b> option from the <b>Search By</b> list.</p>
Pricing Currency	<p>Indicates the currency in which the price item pricing is defined.</p> <p><b>Note:</b> This column appears only when you select the <b>Price List Pricing, Account Override Pricing, or Person Override Pricing</b> option from the <b>Search By</b> list.</p>
Rate Schedule	<p>Indicates the rate schedule which is used for defining the price item pricing.</p> <p><b>Note:</b> It has a link. On clicking the link <b>Rate Schedule</b> screen appears. This column appears only when you select the <b>Price List Pricing, Account Override Pricing, or Person Override Pricing</b> option from the <b>Search By</b> list.</p>
Price Assignment Usage	<p>Indicates whether the price item pricing is applicable to all customers or only to new customers. The valid values are:</p> <ul style="list-style-type: none"> <li>• All Customers</li> <li>• New Customers</li> </ul> <p><b>Note:</b> This column appears only when you select the <b>Price List Pricing, Account Override Pricing, or Person Override Pricing</b> option from the <b>Search By</b> list.</p>
Price Assignment Type	<p>Indicates the type of the price item pricing. The valid values are:</p> <ul style="list-style-type: none"> <li>• Regular</li> <li>• Post Processing</li> <li>• Post Processing – Invoice Based</li> <li>• Post Processing – Price Item Based</li> </ul> <p><b>Note:</b> This column appears only when the <b>Multi Price Parameter</b> option type of the <b>Multi Parameter Based Pricing (C1_PPARM_FLG)</b> feature configuration is set to <b>False</b>.</p>

### Related Topics

For more information on...	See...
How to assign a price item or price item bundle to an account	<a href="#">Assigning a Price Item or Price Item Bundle to an Account</a>
How to copy a price item pricing	<a href="#">Copying a Price Item Pricing</a> on page 455

## Viewing Effective Price Assignments of an Account

### Prerequisites

To view effective price assignments of an account, you should have:

- Price items or price item bundles assigned to the account either directly or through the customer hierarchy

**Procedure**

To view effective price assignments of an account:

1. Search for the account in the **Customer 360° View** screen.
2. In the **Search Results** section, click the **Show Context Menu** () icon corresponding to the account whose details you want to view.  
A menu appears.
3. Click the **Go To Effective Pricing** menu option.  
The **Pricing (Account)** screen appears.
4. View the pricing for price items or price item bundles assigned to the account (either directly or through the customer hierarchy) in the **Effective Price Assignments for Account** zone.
5. Filter the effective price assignments of the account, if required.

**Related Topics**

<b>For more information on...</b>	<b>See...</b>
How to search for an account	<a href="#">Searching for an Account</a> on page 186
<b>Pricing (Account)</b> screen	<a href="#">Pricing (Account)</a> on page 439
<b>Effective Price Assignments for Account</b> zone	<a href="#">Effective Price Assignments for Account</a> on page 440
How to filter effective price assignments of an account	<a href="#">Filtering Effective Price Assignments of an Account</a> on page 451

**Filtering Effective Price Assignments of an Account****Prerequisites**

To filter effective price assignments of an account, you should have:

- Price items or price item bundles defined in the application
- Parameters defined in the application (where the source entity is set to **Transaction**)
- Price items or price item bundles assigned to the account either directly or through the customer hierarchy

**Procedure**

To filter effective price assignments of an account:

1. Search for the account in the **Customer 360° View** screen.
2. In the **Search Results** section, click the **Show Context Menu** () icon corresponding to the account whose details you want to view.  
A menu appears.
3. Click the **Go To Effective Pricing** menu option.  
The **Pricing (Account)** screen appears.
4. Enter the search criteria in the **Effective Price Assignments for Account** zone.

**Note:**

You can search for a price item, parameter, or parameter value by clicking the **Search** () icon corresponding to the respective field.

If you want to add more than one parameter in the search criteria, click the **Add** () icon and then enter the parameter name and its value. However, if you want to remove a parameter from the search criteria, click the

**Delete** () icon corresponding to the parameter.

You can only use those parameters where the source entity is set to **Transaction**.

ORMB search engine supports wildcard search, where you can substitute the percentage (%) symbol as a stand in for any word or letter in a search criteria. You can use the ‘%’ wildcard character in all input fields except the date and ID fields. The ‘%’ wildcard character is suffixed automatically at the end of the partial search criteria. Therefore, you may or may not specify the wildcard character at the end of the partial search criteria. However, you have to prefix the wildcard character manually wherever required.

### 5. Click **Search**.

A list of price assignments which are effective on the specified date and that meet the search criteria are listed in the **Effective Price Assignments for Account** zone.

#### Related Topics

For more information on...	See...
How to search for an account	<a href="#">Searching for an Account</a> on page 186
<b>Pricing (Account)</b> screen	<a href="#">Pricing (Account)</a> on page 439
<b>Effective Price Assignments for Account</b> zone	<a href="#">Effective Price Assignments for Account</a> on page 440

## Exporting Effective Price Assignments of an Account

### Prerequisites

To export effective price assignments of an account in the CSV format, you should have:

- Price items or price item bundles assigned to the account either directly or through the customer hierarchy

### Procedure

To export effective price assignments of an account in the CSV format:

1. Search for the account in the **Customer 360° View** screen.
2. In the **Search Results** section, click the **Show Context Menu** () icon corresponding to the account whose details you want to view.  
A menu appears.
3. Click the **Go To Effective Pricing** menu option.  
The **Pricing (Account)** screen appears.
4. Filter the effective price assignments of the account, if required.
5. Click the **Export to Excel** link in the **Effective Price Assignment** zone.  
A message appears confirming whether you want to open or save the EffectivePricing.csv file.
6. Select the **Save As** option from the **Save** list.  
The **Save As** dialog box appears.

7. Browse to the location where you want to save the file.
8. Enter the file name in the respective field, and click **Save**.

The search results are exported in the CSV format.

9. Open the CSV file in Microsoft Excel.

The sheet contains the following columns:

Column Name	Column Description
Price Item	Displays the price item or price item bundle code.
Description	Displays the description of the price item or price item bundle.
Variance	Indicates the variance parameter which is used for defining the price item pricing.  <b>Note:</b> This column appears only when the <b>Multi Price Parameter</b> option type of the <b>Multi Parameter Based Pricing (C1_PPARM_FLG)</b> feature configuration is set to <b>False</b> .
Price Item Parameters	Displays a comma-separated list of parameter values. The order in which parameter values appear in this column is controlled by the display order (which is defined while associating a parameter with a price item). A tool tip appears when you hover over this column corresponding to the price item. It indicates the price item parameters and their values which are used for defining the price item pricing.  <b>Note:</b> This column appears only when the <b>Multi Price Parameter</b> option type of the <b>Multi Parameter Based Pricing (C1_PPARM_FLG)</b> feature configuration is set to <b>True</b> .
Price Assignment Type	Indicates the type of price assignment. The valid values are: <ul style="list-style-type: none"> <li>• Regular</li> <li>• Post Processing</li> <li>• Post Processing — Invoice Based</li> <li>• Post Processing — Price Item Based</li> </ul>
Assignment Level	Indicates the level at which the price item pricing is defined in the customer hierarchy. The valid values are: <ul style="list-style-type: none"> <li>• Account Agreed</li> <li>• Account Price List</li> <li>• Account Inherited Price List</li> <li>• Customer Agreed</li> <li>• Customer Price List</li> <li>• Customer Inherited Price List</li> <li>• Parent Customer Agreed</li> <li>• Parent Customer Price List</li> <li>• Parent Customer Inherited Price List</li> </ul>

Column Name	Column Description
Price List Description	<p>Displays the description of the price list.</p> <div style="border: 1px solid black; padding: 5px;"> <p><b>Note:</b> The description appears only when the assignment level is <b>Account Price List, Account Inherited Price List, Customer Price List, Customer Inherited Price List, Parent Customer Price List, or Parent Customer Inherited Price List.</b></p> </div>
Rate Description	Displays the description of the rate schedule which is used for defining the price item pricing.
Rate Component Information	<p>Displays a comma-separated string which consists of the following:</p> <ul style="list-style-type: none"> <li>• Rate Component Sequence</li> <li>• Tiering Setup of the Rate Component</li> </ul>
Price Component Sequence	Indicates the sequence number of the price component.
Price Component Description	Displays the description of the price component.
Rate	Indicates the rate defined for the price component.
Effective Start Date	Displays the date from when the price item pricing is effective.
Effective End Date	Displays the date till when the price item pricing is effective.
Pricing Currency	Indicates the currency in which the price item pricing is defined.
From	Displays the lower limit of the tiering range.
To	Displays the upper limit of the tiering range.
Price Assignment Usage	<p>Indicates whether the price item pricing is applicable to all customers or only to the new customers. The valid values are:</p> <ul style="list-style-type: none"> <li>• AC</li> <li>• NC</li> </ul>
Price Assignment ID	Displays the price assignment ID.
Parent Level	Indicates the numerical level of the parent in the customer hierarchy from whom the price item pricing is inherited.
Price List ID	Indicates the price list from where the price item pricing is inherited.
Price List Start Date	Displays the date from when the price list is effective.
Parent Person	Displays the name of the parent or grandparent customer from whom the price item pricing is inherited.
Parent Pricelist Level	Indicates the parent level when price item pricing is inherited from the price list hierarchy. If the pricing is inherited from the assigned price list, the parent price list level will be 0. However, if the pricing is inherited from the parent price list in the hierarchy, the parent price list level will be 1. And, if the pricing is inherited from the grandparent price list in the hierarchy, the parent price list level will be 2, and so on.

Column Name	Column Description
Ignore Transaction	Indicates whether the transactions mapped to the price item is considered for billing. The valid values are: <ul style="list-style-type: none"> <li>• Y</li> <li>• N</li> </ul>
Aggregate Transaction	Indicates whether the transactions mapped to the price item is aggregated for billing. The valid values are: <ul style="list-style-type: none"> <li>• Y</li> <li>• N</li> </ul>
Aggregation Schedule	Indicates the transaction aggregation cycle. The valid values are: <ul style="list-style-type: none"> <li>• Daily</li> <li>• Weekly</li> <li>• Monthly</li> <li>• Quarterly</li> <li>• Yearly</li> </ul>
Tiering Criterion	Indicates the tiering criterion which is used in the tiering range.
Tiering Price Item	Indicates whether the price item is billed individually or at the price item bundle level.

### Related Topics

For more information on...	See...
How to search for an account	<a href="#">Searching for an Account</a>
<b>Pricing (Account)</b> screen	<a href="#">Pricing (Account)</a> on page 439
<b>Effective Price Assignment</b> zone	<a href="#">Effective Price Assignments for Account</a> on page 440

## Copying a Price Item Pricing

### Prerequisites

To copy a price item pricing and assign it to an account, you should have:

- Account (to which you want to assign the price item pricing) defined in the application
- Account associated with the division to which the user belongs
- Price item pricing (whose copy you want to create) defined in the application

### Procedure

To copy a price item pricing and assign it to an account:

1. Search for the account in the **Customer 360° View** screen.
2. In the **Search Results** section, click the **Show Context Menu** () icon corresponding to the account whose details you want to view.  
A menu appears.
3. Click the **Go To Effective Pricing** menu option.

The **Pricing (Account)** screen appears.

- In the **Search Price Item** zone, select the required option from the **Search By** list to indicate whether you want to search price item pricing assigned to an account, person, or a price list.

The fields in the **Search Criteria** section change depending on the option that you select from the **Search By** list.

- Enter the search criteria in the **Search Price Item** zone to search for the price item pricing whose copy you want to create and assign it to the account.
- Click **Search**.

A list of price assignments that meet the search criteria appears in the **Search Results** section.

- In the **Search Results** section, click the **Copy** () icon in the **Copy** column corresponding to the price item pricing whose copy you want to create.

The **Price Item Pricing** screen appears.

- Modify the required pricing details.

**Note:**

If you change the effective start and end dates while copying a price item pricing, you need to specify the parameters which are effective during that date range.

While copying a price item pricing, you can not only edit the existing tiering combination details, but can also add additional tiering combinations until the maximum tiering combinations limit is met.

If you are creating a copy of active, proposed, inactive, rejected, or template price item pricing, you can save the new price item pricing in the **Active** or **Proposed** status.

- Edit the characteristics of the price item pricing, if required.
- Click **Save**.

A new price item pricing is defined and assigned to the account.

### **Related Topics**

<b>For more information on...</b>	<b>See...</b>
How to search for an account	<a href="#">Searching for an Account</a> on page 186
<b>Pricing (Account)</b> screen	<a href="#">Pricing (Account)</a> on page 439
<b>Search Price Item</b> zone	<a href="#">Search Price Item</a> on page 445
How to edit a price item pricing	<a href="#">Editing a Price Item Pricing</a>
How to edit characteristics of a price item pricing	<a href="#">Editing the Price Item Pricing Characteristics</a>

## **Viewing a Price Item Pricing**

### **Procedure**

To view a price item pricing and assignment details:

- Search for the account in the **Customer 360° View** screen.
- In the **Search Results** section, click the **Show Context Menu** () icon corresponding to the account whose details you want to view.

A menu appears.



- Click the **Go To Effective Pricing** menu option.

The **Pricing (Account)** screen appears.

- Price assignments effective for the account appears in the **Effective Price Assignments for Account** zone.
- In the **Search Results** section, click the link in the **Pricing Information** column corresponding to the price item whose pricing details you want to view.

The **Price Item Pricing** screen appears. It contains the following zones:

- Price Item Pricing** – Displays the price item pricing details. It contains the following sections:
  - Pricing Information** – Displays the pricing information of the price item.
  - TFM Information** – Displays the transaction feed management information of the price item.
  - Characteristics** – Displays the details of price item pricing characteristics.
  - Price Item and Parameter Information** – Displays the price item parameter details.
  - Record Actions** – Displays the record actions of the price item pricing.
  - Record Information** – Displays the record information of the price item pricing.
- Rate and Price Component Summary** – Displays the rate and price component summary of the price item.
- Rate Components** – Displays the rate components of the price item.
- Price Components** – Displays the details of price components of the price item.
- Tiering Criteria** – Displays the tiering criteria of the price item pricing.

**Note:** This zone appears only when **Tiering Type** for the rate component is **STEP** or **Threshold**

- Pricing Eligibility Criteria** – Displays the pricing eligibility criteria of the price item pricing.

**Note:** This zone appears only when eligibility checkbox is selected in the **Price Item Pricing** screen and details for pricing eligibility criteria is added in the **Price Component** screen.

- View the basic details of price item pricing in the **Price Item Pricing** zone.
- View the rate and price component summary of price item in the **Rate and Price Component Summary** zone.
- View the rate components of price item in the **Rate Components** zone.
- View the details of price components of price item in the **Price Components** zone.
- View the tiering criteria of price item pricing in the **Tiering Criteria** zone.
- View the pricing eligibility criteria of price item pricing in the **Pricing Eligibility Criteria** zone.

### **Related Topics**

<b>For more information on...</b>	<b>See...</b>
How to search for an account	<a href="#">Searching for an Account</a> on page 186
<b>Pricing (Account)</b> screen	<a href="#">Pricing (Account)</a> on page 439
<b>Effective Price Assignments for Account</b> zone	<a href="#">Effective Price Assignments for Account</a> on page 440
<b>Price Item Pricing</b> screen	<a href="#">Price Item Pricing (Used for Viewing)</a> on page 507
<b>Price Item Pricing</b> zone	<a href="#">Price Item Pricing</a> on page 508
<b>Rate and Price Component Summary</b> zone	<a href="#">Rate and Price Component Summary</a> on page 511
<b>Rate Components</b> zone	<a href="#">Rate Components</a> on page 512

For more information on...	See...
Price Components zone	<a href="#">Price Components</a> on page 512
Tiering Criteria zone	<a href="#">Tiering Criteria</a> on page 514
Pricing Eligibility Criteria zone	<a href="#">Pricing Eligibility Criteria</a> on page 514

## Editing a Price Item Pricing of an Account

### Prerequisites

To edit a price item pricing of an account, you should have:

- Transactions mapped to the price item defined in the application
- Rate schedules, rate versions, rate components defined in the application
- Parameters associated with the price item (in case you want to define price item pricing based on those parameters)

### Procedure

To edit a price item pricing of an account:

1. Search for the account in the **Customer 360° View** screen.
2. In the **Search Results** section, click the **Show Context Menu** (☰) icon corresponding to the account whose details you want to view.  
A menu appears.
3. Click the **Go To Effective Pricing** menu option.  
The **Pricing (Account)** screen appears.
4. Price assignments effective for the account appears in the **Effective Price Assignments for Account** zone.
5. In the **Search Results** section, click the **Edit** (✎) icon in the **Edit** column corresponding to the price item pricing whose details you want to edit.

The **Price Item Pricing** screen appears. It contains the following sections:

- **Main** – Used to specify basic details about the price item pricing.
- **TFM Information** – Used to specify the transaction feed management information about the price item pricing.

**Note:** This section appears in the **Price Item Pricing** screen only when the value for the **Show Default Values in Price Item Pricing** option type for **C1\_FM** feature configuration is set to **Y** and **Price Item Available For** is **Pricing and Billing**.

- **Characteristics** – Used to define characteristics for the price item pricing.
- **Price Item and Parameter Information** – Used to define the parameter details segment for the price item pricing.

**Note:** This section appears only when **Price Assignment Type** is **Regular**.

The **Main** section contains the following fields:

Field Name	Field Description	Mandatory (Yes or No)
Start Date	<p>Used to specify the date from when the price item pricing is effective.</p> <div data-bbox="548 289 1105 659" style="border: 1px solid black; padding: 5px;"> <p><b>Note:</b></p> <p>The effective start date cannot be later than the effective end date.</p> <p>If you change the effective start and end dates while editing a price item pricing, you need to specify the parameters which are effective during that date range.</p> <p>This field will be in read-only mode when the price assignment has been used.</p> </div>	Yes
End Date	<p>Used to specify the date till when the price item pricing is effective.</p> <div data-bbox="548 768 1105 848" style="border: 1px solid black; padding: 5px;"> <p><b>Note:</b> The effective end date cannot be earlier than the effective start date.</p> </div>	No

Field Name	Field Description	Mandatory (Yes or No)
Price Assignment Type	<p>Used to indicate the type of price assignment. The valid values are:</p> <ul style="list-style-type: none"> <li>• <b>Regular</b> – Used to indicate that the pricing must be used to generate regular bill segment.</li> <li>• <b>Post Processing</b> – Used to indicate that the pricing must be used to generate post processing bill segment. This type of price assignment can be done on usage accounts. The post processing bill segment is generated when you generate the bill for the usage account and not when you bill the usage account through an invoice account.</li> </ul> <div data-bbox="613 640 1109 915" style="border: 1px solid black; padding: 5px;"> <p><b>Note:</b> The post processing bill segment is generated when the <b>Post Processing Sequence (PPSEQ)</b> characteristic is defined for the price item and when the price item is associated with another price item using the <b>Price Item</b> relationship type.</p> </div> <ul style="list-style-type: none"> <li>• <b>Post Processing – Invoice Based</b> – Used to indicate that the pricing must be used to generate post processing bill segment. This type of price assignment can be done on an invoice account, and, as a result, the post processing bill segment is generated on the invoice account.</li> </ul> <div data-bbox="613 1171 1109 1255" style="border: 1px solid black; padding: 5px;"> <p><b>Note:</b> This will not be applicable for price item which are defined for <b>Only Pricing</b>.</p> </div> <ul style="list-style-type: none"> <li>• <b>Post Processing – Price Item Based</b> – Used to indicate that the pricing must be used to generate post processing bill segment. This type of price assignment can be done on both invoice and usage accounts, but the post processing bill segment is generated only on the invoice account.</li> </ul> <div data-bbox="613 1512 1109 1596" style="border: 1px solid black; padding: 5px;"> <p><b>Note:</b> This will not be applicable for price item which are defined for <b>Only Pricing</b>.</p> </div>	Yes
Pricing Eligibility	<p>Used to select pricing eligibility criteria for price item pricing.</p> <div data-bbox="548 1703 1109 1818" style="border: 1px solid black; padding: 5px;"> <p><b>Note:</b> This field will be enabled for selection if the checkbox is not selected. If the checkbox appears selected then this field will be in read-only mode.</p> </div>	No

Field Name	Field Description	Mandatory (Yes or No)
Pricing Status	<p>Used to indicate the status of the price assignment. The valid values are:</p> <ul style="list-style-type: none"> <li>• <b>Draft</b> – Indicates that the price assignment is created as a draft.</li> <li>• <b>Active</b> – Indicates that the price assignment is used for billing.</li> <li>• <b>Inactive</b> – Indicates that the price assignment is no longer used for billing.</li> <li>• <b>Proposed</b> – Indicates that the price assignment is used for quotations.</li> </ul> <p><b>Note:</b> If a price assignment is in <b>Active</b> status, you can change its status to <b>Inactive</b>. If a price assignment is in <b>Draft</b> status, you cannot change its status to <b>Proposed</b>.</p>	Yes
Pricing Currency	Used to indicate the currency in which you want to define the price item pricing.	Yes
Rate Schedule	<p>Used to specify the rate schedule that you want to use while defining price item pricing.</p> <p><b>Note:</b> Rate schedules control how the bills for the price item will be calculated. The <b>Search</b> (🔍) icon appears corresponding to this field. On clicking the <b>Search</b> icon, the <b>Rate Schedule Search</b> screen appears.</p>	Yes
Pricing Rule Type	<p>Used to indicate the pricing rule type. The valid value is:</p> <ul style="list-style-type: none"> <li>• Two-Dimensional</li> </ul>	Yes (Conditional)
Print Zero	<p>Used to indicate whether zero pricing should be displayed in the bill. The valid values are:</p> <ul style="list-style-type: none"> <li>• Yes</li> <li>• No</li> </ul> <p><b>Note:</b> By default, <b>Yes</b> is selected.</p>	Yes
Pricing Frequency	<p>Used to indicate pricing frequency for the price item.</p> <p><b>Note:</b> This field appears only when <b>Price Item</b> is defined as <b>Only Pricing</b> and <b>Price Item Type</b> is defined as <b>Fees</b>.</p>	Yes

6. Modify the details in the **Main** section, if required.
7. Edit the TFM Information in a price item pricing, if required.
8. Edit the characteristics for a price item pricing, if required.
9. Edit the parameters for a price item pricing, if required.
10. Click **Save**.

The changes made to the price item pricing are saved.

### Related Topics

For more information on...	See...
How to search for an account	<a href="#">Searching for an Account</a> on page 186
<b>Pricing (Account)</b> screen	<a href="#">Pricing (Account)</a> on page 439
<b>Effective Price Assignments for Account</b> zone	<a href="#">Effective Price Assignments for Account</a> on page 440
How to define a price item pricing.	<a href="#">Defining a Price Item Pricing</a> on page 516
How to define characteristics for a price item pricing.	<a href="#">Defining Characteristics for a Price Item Pricing</a> on page 405
How to define parameters for a price item pricing.	<a href="#">Defining Parameters for a Price Item Pricing</a> on page 406
How to define TFM Information in a price item pricing.	<a href="#">Defining TFM Information in a Price Item Pricing</a> on page 407

## Overriding a Price Item Pricing of an Account



### Prerequisites

To override a price item pricing of an account, you should have:

- Transactions mapped to the price item defined in the application
- Rate schedules, rate versions, rate components defined in the application
- Parameters associated with the price item (in case you want to define price item pricing based on multiple parameters)

### Procedure

To override a price item pricing of an account:

1. Search for the account in the **Customer 360° View** screen.
2. In the **Search Results** section, click the **Show Context Menu** () icon corresponding to the account whose details you want to view.  
A menu appears.
3. Click the **Go To Effective Pricing** menu option.  
The **Pricing (Account)** screen appears.
4. Price assignments effective for the account appears in the **Effective Price Assignments for Account** zone.
5. In the **Search Results** section, click the **Override** () icon in the **Override** column corresponding to the price item pricing whose details you want to override.

The **Price Item Pricing** screen appears. It contains the following sections:

- **Main** – Used to specify basic details about the price item pricing.

- **TFM Information** – Used to specify the transaction feed management information about the price item pricing.

**Note:** This section appears in the **Price Item Pricing** screen only when the value for the **Show Default Values in Price Item Pricing** option type for **C1\_FM** feature configuration is set to **Y** and **Price Item Available For** is **Pricing and Billing**.

- **Characteristics** – Used to define characteristics for the price item pricing.
- **Price Item and Parameter Information** – Used to define the parameter details segment for the price item pricing.

**Note:** This section appears only when **Price Assignment Type** is **Regular**.

The **Main** section contains the following fields:

Field Name	Field Description	Mandatory (Yes or No)
Start Date	Used to specify the date from when the price item pricing is effective.  <b>Note:</b> The effective start date cannot be later than the effective end date. If you change the effective start and end dates while overriding a price item pricing, you need to specify the parameters which are effective during that date range. This field will be in read-only mode when the price assignment has been used.	Yes
End Date	Used to specify the date till when the price item pricing is effective.  <b>Note:</b> The effective end date cannot be earlier than the effective start date.	No

Field Name	Field Description	Mandatory (Yes or No)
Price Assignment Type	<p>Used to indicate the type of price assignment. The valid values are:</p> <ul style="list-style-type: none"> <li>• <b>Regular</b> – Used to indicate that the pricing must be used to generate regular bill segment.</li> <li>• <b>Post Processing</b> – Used to indicate that the pricing must be used to generate post processing bill segment. This type of price assignment can be done on usage accounts. The post processing bill segment is generated when you generate the bill for the usage account and not when you bill the usage account through an invoice account.</li> </ul> <div data-bbox="599 611 1175 852" style="border: 1px solid black; padding: 5px;"> <p><b>Note:</b> The post processing bill segment is generated when the <b>Post Processing Sequence (PPSEQ)</b> characteristic is defined for the price item and when the price item is associated with another price item using the <b>Price Item</b> relationship type.</p> </div> <ul style="list-style-type: none"> <li>• <b>Post Processing – Invoice Based</b> – Used to indicate that the pricing must be used to generate post processing bill segment. This type of price assignment can be done on an invoice account, and, as a result, the post processing bill segment is generated on the invoice account.</li> </ul> <div data-bbox="599 1077 1175 1157" style="border: 1px solid black; padding: 5px;"> <p><b>Note:</b> This will not be applicable for price item which are defined for <b>Only Pricing</b>.</p> </div> <ul style="list-style-type: none"> <li>• <b>Post Processing – Price Item Based</b> – Used to indicate that the pricing must be used to generate post processing bill segment. This type of price assignment can be done on both invoice and usage accounts, but the post processing bill segment is generated only on the invoice account.</li> </ul> <div data-bbox="599 1381 1175 1461" style="border: 1px solid black; padding: 5px;"> <p><b>Note:</b> This will not be applicable for price item which are defined for <b>Only Pricing</b>.</p> </div>	Yes
Pricing Eligibility	<p>Used to select pricing eligibility criteria for price item pricing.</p> <div data-bbox="532 1577 1175 1688" style="border: 1px solid black; padding: 5px;"> <p><b>Note:</b> This field will be in enabled for selection if the checkbox is not selected. If the checkbox appears selected then this field will be in read-only mode.</p> </div>	No



Field Name	Field Description	Mandatory (Yes or No)
Pricing Status	Used to indicate the status of the price assignment. The valid values are: <ul style="list-style-type: none"> <li>• <b>Draft</b> – Indicates that the price assignment is created as a draft.</li> <li>• <b>Proposed</b> – Indicates that the price assignment is used for quotations.</li> </ul> <div style="border: 1px solid black; padding: 2px;"><b>Note:</b> If a price assignment is in <b>Draft</b> status, you cannot change its status to <b>Proposed</b>.</div>	Yes
Pricing Currency	Used to indicate the currency in which you want to override the price item pricing.	Yes
Rate Schedule	Used to specify the rate schedule that you want to use while defining price item pricing. <div style="border: 1px solid black; padding: 2px;"><b>Note:</b> Rate schedules control how the bills for the price item will be calculated. The <b>Search</b> (🔍) icon appears corresponding to this field. On clicking the <b>Search</b> icon, the <b>Rate Schedule Search</b> screen appears.</div>	Yes
Pricing Rule Type	Used to indicate the pricing rule type. The valid value is: <ul style="list-style-type: none"> <li>• Two-Dimensional</li> </ul>	Yes (Conditional) <div style="border: 1px solid black; padding: 2px;"><b>Note:</b> This field is required when you are overriding a two-dimensional pricing rule.</div>
Print Zero	Used to indicate whether zero pricing should be displayed in the bill. The valid values are: <ul style="list-style-type: none"> <li>• Yes</li> <li>• No</li> </ul> <div style="border: 1px solid black; padding: 2px;"><b>Note:</b> By default, <b>Yes</b> is selected.</div>	Yes
Pricing Frequency	Used to indicate pricing frequency for the price item. <div style="border: 1px solid black; padding: 2px;"><b>Note:</b> This field appears only when <b>Price Item</b> is defined as <b>Only Pricing</b> and <b>Price Item Type</b> is defined as <b>Fees</b>.</div>	Yes

6. Modify the details in the **Main** section, if required.
7. Modify the TFM Information in a price item pricing, if required.
8. Modify the characteristics for a price item pricing, if required.
9. Modify the parameters for a price item pricing, if required.

**Note:** If you change the effective end date while overriding a price item pricing, you need to specify the parameters which are effective during the date range of start and end date.

**10. Click Save.**

The price item pricing is overridden.

**Related Topics**

<b>For more information on...</b>	<b>See...</b>
How to search for an account	<a href="#">Searching for an Account</a> on page 186
<b>Pricing (Account)</b> screen	<a href="#">Pricing (Account)</a> on page 439
<b>Effective Price Assignments for Account</b> zone	<a href="#">Effective Price Assignments for Account</a> on page 440
How to define a price item pricing.	<a href="#">Defining a Price Item Pricing</a> on page 516
How to define characteristics for a price item pricing.	<a href="#">Defining Characteristics for a Price Item Pricing</a> on page 405
How to define parameters for a price item pricing.	<a href="#">Defining Parameters for a Price Item Pricing</a> on page 406
How to define TFM Information in a price item pricing.	<a href="#">Defining TFM Information in a Price Item Pricing</a> on page 407



**Assigning a Price Item to an Account****Prerequisites**

To assign a price item to an account, you should have:

- Transactions mapped to the price item defined in the application
- Rate schedules, rate versions, and rate components defined in the application
- Parameters associated with the price item (in case you want to define price item pricing based on multiple parameters)

**Procedure**

To assign a price item to an account:

1. Search for the account in the **Customer 360° View** screen.
2. In the **Search Results** section, click the **Show Context Menu** () icon corresponding to the account whose details you want to view.  
A menu appears.
3. Click the **Go To Effective Pricing** menu option.  
The **Pricing (Account)** screen appears.
4. Search for the price item that you want to assign to the account in the **Search Price Item or Price Item Pricing** zone.
5. In the **Search Results** section, click the **Assign** () icon in the **Assign** column corresponding to the price item that you want to assign to the account.

The **Price Item Pricing** screen appears. It contains the following sections:

- **Main** – Used to specify basic details about the price item pricing.
- **TFM Information** – Used to specify the transaction feed management information about the price item pricing.

**Note:** This section appears in the **Price Item Pricing** screen only when the value for the **Show Default Values in Price Item Pricing** option type for **C1\_FM** feature configuration is set to **Y** and **Price Item Available For** is **Pricing and Billing**.

- **Characteristics** – Used to define characteristics for the price item pricing.
- **Price Item and Parameter Information** – Used to define the parameter details segment for the price item pricing.

**Note:** This section appears only when **Price Assignment Type** is **Processing**.

The **Main** section contains the following fields:

Field Name	Field Description	Mandatory (Yes or No)
Start Date	Used to specify the date from when the price item pricing is effective.  <div style="border: 1px solid black; padding: 5px;"> <p><b>Note:</b> By default, the current system date appears in this field. The effective start date cannot be later than the effective end date.</p> </div>	Yes
End Date	Used to specify the date till when the price item pricing is effective.  <div style="border: 1px solid black; padding: 5px;"> <p><b>Note:</b> The effective end date cannot be earlier than the effective start date.</p> </div>	No

Field Name	Field Description	Mandatory (Yes or No)
Price Assignment Type	<p>Used to indicate the type of price assignment. The valid values are:</p> <ul style="list-style-type: none"> <li>• <b>Regular</b> – Used to indicate that the pricing must be used to generate regular bill segment.</li> <li>• <b>Post Processing</b> – Used to indicate that the pricing must be used to generate post processing bill segment. This type of price assignment can be done on usage accounts. The post processing bill segment is generated when you generate the bill for the usage account and not when you bill the usage account through an invoice account.</li> </ul> <div data-bbox="613 606 1200 850" style="border: 1px solid black; padding: 5px;"> <p><b>Note:</b> The post processing bill segment is generated when the <b>Post Processing Sequence (PPSEQ)</b> characteristic is defined for the price item and when the price item is associated with another price item using the <b>Price Item</b> relationship type.</p> </div> <ul style="list-style-type: none"> <li>• <b>Post Processing – Invoice Based</b> – Used to indicate that the pricing must be used to generate post processing bill segment. This type of price assignment can be done on an invoice account, and, as a result, the post processing bill segment is generated on the invoice account.</li> </ul> <div data-bbox="613 1075 1200 1157" style="border: 1px solid black; padding: 5px;"> <p><b>Note:</b> This will not be applicable for price item which are defined for <b>Only Pricing</b>.</p> </div> <ul style="list-style-type: none"> <li>• <b>Post Processing – Price Item Based</b> – Used to indicate that the pricing must be used to generate post processing bill segment. This type of price assignment can be done on both invoice and usage accounts, but the post processing bill segment is generated only on the invoice account.</li> </ul> <div data-bbox="613 1381 1200 1463" style="border: 1px solid black; padding: 5px;"> <p><b>Note:</b> This will not be applicable for price item which are defined for <b>Only Pricing</b>.</p> </div>	Yes
Pricing Eligibility	Used to select pricing eligibility criteria for price item pricing.	No
Pricing Status	<p>Used to indicate the status of the price assignment. The valid values are:</p> <ul style="list-style-type: none"> <li>• <b>Draft</b> – Indicates that the price assignment is created as a draft.</li> <li>• <b>Proposed</b> – Indicates that the price assignment is used for quotations.</li> </ul>	Yes
Pricing Currency	Used to indicate the currency in which you want to define the price item pricing.	Yes

Field Name	Field Description	Mandatory (Yes or No)
Rate Schedule	Used to specify the rate schedule that you want to use while defining price item pricing.  <b>Note:</b> Rate schedules control how the bills for the price item will be calculated.  The <b>Search</b> (🔍) icon appears corresponding to this field. On clicking the <b>Search</b> icon, the <b>Rate Schedule Search</b> screen appears.	Yes
Pricing Rule Type	Used to indicate the pricing rule type. The valid value is: <ul style="list-style-type: none"> <li>Two-Dimensional</li> </ul>	Yes (Conditional)  <b>Note:</b> This field is required when you are defining a two-dimensional pricing rule.
Print Zero	Used to indicate whether zero pricing should be displayed in the bill. The valid values are: <ul style="list-style-type: none"> <li>Yes</li> <li>No</li> </ul> <b>Note:</b> By default, <b>Yes</b> is selected.	Yes
Pricing Frequency	Used to indicate pricing frequency for the price item.  <b>Note:</b> This field appears only when <b>Price Item</b> is defined as <b>Only Pricing</b> and <b>Price Item Type</b> is defined as <b>Fees</b> .	Yes

- Enter the required details in the **Main** section.
- Define TFM Information in a price item pricing, if required.
- Define characteristics for a price item pricing, if required.
- Define parameters for a price item pricing, if required.
- Click **Save**.

The pricing is defined for the price item.

**Note:** A bundle cannot be assigned if its child price items are already assigned to an account and vice versa, in the same date range.

### Related Topics

For more information on...	See...
<b>Pricing (Account)</b> screen	<a href="#">Pricing (Account)</a> on page 439
<b>Search Price Item or Price Item Pricing</b> zone	<a href="#">Search Price Item</a> on page 445
How to search for an account	<a href="#">Searching for an Account</a> on page 186

For more information on...	See...
How to define characteristics for a price item pricing.	<a href="#">Defining Characteristics for a Price Item Pricing</a> on page 405
How to define parameters for a price item pricing.	<a href="#">Defining Parameters for a Price Item Pricing</a> on page 406
How to define TFM Information in a price item pricing.	<a href="#">Defining TFM Information in a Price Item Pricing</a> on page 407

## Defining Characteristics for a Price Item Pricing

### Prerequisites

To define characteristics for a price item pricing, you should have:

- Characteristic types defined in the application (where the characteristic entity is set to **Price Item**)

### Procedure

To define characteristics for a price item pricing that is assigned to an account:

1. Ensure that the **Characteristics** section is expanded when you are defining a price item pricing.

The **Characteristics** section contains the following columns:

Column Name	Column Description	Mandatory (Yes or No)
Effective Date	Used to specify the date from when the characteristic is effective for the price item pricing.	Yes (Conditional) <b>Note:</b> This field is required when you are defining a characteristic for the price item pricing.
Characteristic Type	Used to indicate the characteristic type. <b>Note:</b> The list includes only those characteristic types where the characteristic entity is set to <b>Price Item Pricing</b> .	Yes (Conditional) <b>Note:</b> This field is required when you are defining a characteristic for the price item pricing.
Characteristic Value	Used to specify the value for the characteristic type. <b>Note:</b> If you select a predefined characteristic type, the <b>Search</b> (🔍) icon appears corresponding to the <b>Characteristic Value</b> field. On clicking the <b>Search</b> icon, the <b>Predefined Characteristic Search</b> window appears. On specifying the value for a predefined characteristic type, the description of the characteristic value appears corresponding to the <b>Characteristic Value</b> field.	Yes (Conditional) <b>Note:</b> This field is required when you are defining a characteristic for the price item pricing.

2. Enter the required details in the **Characteristics** section.
3. If you want to define more than one characteristic for the price item pricing, click the **Add** (+) icon and then repeat step 3.

**Note:** However, if you want to remove a characteristic from the price item pricing, click the **Delete** (🗑️) icon corresponding to the characteristic.

4. Click **Save**.

The characteristics are defined for the price item pricing.

### **Related Topics**

<b>For more information on...</b>	<b>See...</b>
How to define a price item pricing	<a href="#">Defining a Price Item Pricing</a> on page 516
How to edit a price item pricing	<a href="#">Editing a Price Item Pricing</a> on page 560
How to override a price item pricing	<a href="#">Overriding a Price Item Pricing</a> on page 569

## **Defining Parameters for a Price Item Pricing**

### **Prerequisites**

To define parameters for a price item pricing, you should have:

- Parameters associated with the price item, in case, you want to define price item pricing based on multiple parameters

### **Procedure**

To define parameter details segment for a price item pricing that is assigned to an account:

1. Ensure that the **Price Item and Parameter Information** section is expanded when you are defining a price item pricing.

The **Price Item and Parameter Information** section contains the following field:

<b>Field Name</b>	<b>Field Description</b>
Price Item	Indicates the price item or price item bundle whose pricing details are listed in this section.

In addition, this section contains a grid which has the following columns:

<b>Column Name</b>	<b>Column Description</b>	<b>Mandatory (Yes or No)</b>
Parameter	Used to indicate the parameter that you want to associate with the price item pricing.  <b>Note:</b> The <b>Search</b> (🔍) icon appears corresponding to this field. On clicking the <b>Search</b> icon, the <b>Price Item Parameter Search</b> window appears. The parameter search results displays only those parameters where the <b>Price Item</b> check box is selected	Yes
Parameter Information	Displays a comma-separated string which contains of the following: <ul style="list-style-type: none"> <li>Parameter Description</li> <li>Mandatory (Yes or No)</li> <li>Priority</li> </ul>	Not applicable

Column Name	Column Description	Mandatory (Yes or No)
Parameter Value	Used to specify the value of the parameter.	Yes

- Enter the required details in the **Price Item and Parameter Information** section.
- If you want to define more than one parameter information for the price item pricing, click the **Add (+)** icon and then repeat step 2.

**Note:** However, if you want to remove a parameter information from the price item pricing, click the **Delete** (🗑️) icon corresponding to the parameter.

- Click **Save**.

The parameters are defined for the price item pricing.

### Related Topics

For more information on...	See...
How to define a price item pricing	<a href="#">Defining a Price Item Pricing</a> on page 516
How to edit a price item pricing	<a href="#">Editing a Price Item Pricing</a> on page 560
How to override a price item pricing	<a href="#">Overriding a Price Item Pricing</a> on page 569

## Defining TFM Information in a Price Item Pricing

### Prerequisites

To define the TFM information in a price item pricing, you should have:

- Transactions mapped to the price item defined in the application
- Aggregation or Rating Criteria data to be defined for the price item pricing

### Procedure

To define the TFM information in a price item pricing:

- Ensure that the **TFM Information** section is expanded when you are defining a price item pricing.

The **TFM Information** section contains the following fields:

Field Name	Field Description	Mandatory (Yes or No)
Ignore Transaction	Used to indicate whether the transactions mapped to the price item is considered for billing. The valid values are: <ul style="list-style-type: none"> <li>• Yes</li> <li>• No</li> </ul>	Yes
Aggregate Transactions	Used to indicate whether the transactions mapped to the price item is aggregated for billing. The valid values are: <ul style="list-style-type: none"> <li>• Yes</li> <li>• No</li> </ul>	Yes



Field Name	Field Description	Mandatory (Yes or No)
Aggregation Schedule	Used to indicate the transaction aggregation cycle. The valid values are: <ul style="list-style-type: none"> <li>• Daily</li> <li>• Weekly</li> <li>• Monthly</li> <li>• Quaterly</li> <li>• Yearly</li> </ul>	Yes
Transaction Rating Criteria	Used to indicate how and when the transaction legs mapped to the price item are rated. The valid values are: <ul style="list-style-type: none"> <li>• Aggregate Transactions and Then Rate Aggregated SQs</li> <li>• Do Not Rate Transactions</li> <li>• Rate Transaction and Aggregate Calc Lines Across Transaction</li> </ul>	Yes

2. Enter the required details in the **TFM Information** section.

**Note:** **TFM Information** section appears when the value for **Show Default Values in Price Item Pricing** option type of **C1\_FM feature configuration** is set to **Y** and **Price Item Available For** is **Pricing and Billing**.

3. Click **Save**.

The transactions are defined for the price item pricing.

### **Related Topics**

For more information on...	See...
How to define a price item pricing for an account	<a href="#">Assigning a Price Item to an Account</a> on page 466
How to edit a price item pricing for an account	<a href="#">Editing a Price Item Pricing of an Account</a> on page 458
How to override a price item pricing for an account	<a href="#">Overriding a Price Item Pricing of an Account</a> on page 462
How to define a price item pricing for a person	<a href="#">Assigning a Price Item to a Person</a> on page 500
How to edit a price item pricing for a person	<a href="#">Editing a Price Item Pricing of a Person</a> on page 492
How to override a price item pricing for a person	<a href="#">Overriding a Price Item Pricing of a Person</a> on page 496
How to define a price item pricing for a price list	<a href="#">Assigning a Price Item to a Price List</a> on page 401
How to edit a price item pricing for a price list	<a href="#">Editing a Price Item Pricing of a Price List</a> on page 397

## **Pricing (Person)**

The **Pricing (Person)** screen allows you to:

- View effective price assignments of a person
- View the details of an assigned or inherited price item pricing
- Search and assign price items or price item bundles to a person

- Edit or override a price item pricing
- Copy a price item pricing and assign it to a person

You can also view effective price assignments of a global person (i.e. a person who is not associated to any division) in this screen. The pricing for all price items or price item bundles assigned to the global person either directly or through a price list appears in this screen. However, you will be able to view pricing for only those price items or price item bundles that are associated to the division to which you have access.

Since a global person is not associated to any division, the system cannot determine the price assignment search order for a global person. Hence, the default search order is defined for global persons through the **C1\_PRASNORDR** feature configuration. This feature configuration contains the **Price Assignment Algorithm** option type where you need to specify the algorithm which contains default search order for global persons. You can change this default search order, if required. The valid search order values are — **AGREED\_PRICELIST** and **AGREED\_FIRST**. You can also create a custom search order, if required.

This screen consists of the following zones:

- [Effective Price Assignments for Person](#) on page 474
- [Search Price Item](#) on page 479

## Effective Price Assignments for Person

The **Effective Price Assignments for Person** zone lists the price item pricing (i.e. price assignments) which are effective on the current date. In other words, it lists effective pricing for price items or price item bundles assigned to the person either directly or through the customer hierarchy. The order in which the price assignments are listed is controlled by the **Price Assignment Search** algorithm defined for the division to which the person belongs. If required, you can filter effective price assignments using various search criteria.

**Note:** If the effective pricing is available for the price item, regular bundle (to which the price item belongs), and parent (regular) bundle (i.e. to which the regular bundle belongs) at the same level, the system lists the pricing depending on the value defined for the **Prefer Price Item Over Bundle** parameter in the price assignment search algorithm. If the value of the **Prefer Price Item Over Bundle** parameter is set to **Y**, the system lists effective pricing which is available for the price item. If the effective pricing is not available for the price item, then the system lists effective pricing which is available for the regular bundle at the same level. If the effective pricing is not available for the regular bundle, then the system lists effective pricing which is available for the parent bundle at the same level. However, if the value of the **Prefer Price Item Over Bundle** parameter is set to **N**, the system lists effective pricing which is available for the parent bundle. If the effective pricing is not available for the parent bundle, then the system lists effective pricing which is available for the regular bundle at the same level. If the effective pricing is not available for the regular bundle, then the system lists effective pricing which is available for the price item at the same level.

This zone contains the following two sections:

- **Search Criteria** — The **Search Criteria** section contains the following fields:

Field Name	Field Description	Mandatory (Yes or No)
Person ID	Indicates the person whose effective price assignments are listed in this zone.	Not applicable
Effective Pricing Date	Used to search price assignments which are effective on a particular date.  <b>Note:</b> By default, this field is set to the current date.	No

Field Name	Field Description	Mandatory (Yes or No)
Assignment Level	<p>Used to search price assignments at a particular level in the customer hierarchy. The valid values are:</p> <ul style="list-style-type: none"> <li>• <b>Customer Agreed</b> – Means price item pricing is agreed for the main customer in the customer hierarchy.</li> <li>• <b>Customer Price List</b> – Means price item pricing is defined in the price list which is assigned to the main customer.</li> <li>• <b>Customer Inherited Price List</b> – Means price item pricing is inherited from the parent price list hierarchy defined for the price list which is assigned to the main customer.</li> <li>• <b>Default Price List</b> – Means price item pricing defined in the price list is available in the default price list.</li> <li>• <b>Global Price List</b> – Means price item pricing defined in the price list is available in the global price list.</li> <li>• <b>Parent Customer Agreed</b> – Means price item pricing is agreed for the parent customer in the customer hierarchy.</li> <li>• <b>Parent Customer Price List</b> – Means price item pricing is defined in the price list which is assigned to the parent customer.</li> <li>• <b>Parent Customer Inherited Price List</b> – Means price item pricing is inherited from the parent price list hierarchy defined for the price list which is assigned to the parent customer.</li> </ul>	No
Parent Person	Used to search price assignments which are inherited from a particular parent customer.	No
Pricing Status	<p>Used to search price assignments with a particular status. The valid values are:</p> <ul style="list-style-type: none"> <li>• Active</li> <li>• Proposed</li> </ul> <p><b>Note:</b> By default, the <b>Active</b> option is selected.</p>	No



Field Name	Field Description	Mandatory (Yes or No)
Show Default and Global Pricing	<p>Used to indicate whether you want to search price assignments inherited from the default or global price list. The valid values are:</p> <ul style="list-style-type: none"> <li>• <b>Yes</b> – Used when you want to search price assignments inherited from either of the following: <ul style="list-style-type: none"> <li>• Default price list defined for the division</li> <li>• Global price list</li> </ul> </li> <li>• <b>No</b> – Used when you do not want to search price assignments inherited from either of the following: <ul style="list-style-type: none"> <li>• Default price list defined for the division</li> <li>• Global price list</li> </ul> </li> </ul> <p><b>Note:</b> By default, the <b>No</b> option is selected.</p>	No
Price Item	Used to search price assignments of a particular price item or price item bundle.	No
Description	Used to search price assignments of a price item or price item bundle having a particular description.	No
Search Type	<p>Used to search the price list using the following values:</p> <ul style="list-style-type: none"> <li>• Best Fit</li> <li>• Exact Match</li> </ul> <p><b>Note:</b> By default, the <b>Exact Match</b> option is selected.</p>	No

**Note:** The **Search**  icon appears corresponding to the **Price Item** field. On clicking the **Search** icon, you can search for a price item.

- **Price Item Parameters** – The **Price Item Parameters** section contains the following fields:



Field Name	Field Description	Mandatory (Yes or No)
Parameter	<p>Used to search price assignments which are defined using a particular parameter.</p> <p><b>Note:</b> This field appears only when the <b>Multi Price Parameter</b> option type of the <b>Multi Parameter Based Pricing (C1_PPARM_FLG)</b> feature configuration is set to <b>True</b>.</p>	No

Field Name	Field Description	Mandatory (Yes or No)
Parameter Value	Used to search price assignments which are defined using a particular parameter value.  <b>Note:</b> This field appears only when the <b>Multi Price Parameter</b> option type of the <b>Multi Parameter Based Pricing (C1_PPARM_FLG)</b> feature configuration is set to <b>True</b> .	No

<p><b>Note:</b></p> <p>The <b>Search</b>  icon appears corresponding to the <b>Parameter</b> field. On clicking the <b>Search</b> icon, you can search for a parameter.</p> <p>You can only use those parameters where the source entity is set to <b>Transaction</b>.</p> <p>The <b>Search</b>  icon appears corresponding to the <b>Parameter Value</b> field only when the value type of the parameter is <b>Predefined</b> or <b>Reference</b>. If the value type of the parameter is <b>Predefined</b> then on clicking the <b>Search</b> icon, you can search for a predefined parameter value. However, if the value type of the parameter is <b>Reference</b> then on clicking the <b>Search</b> icon, you can search for a reference parameter value.</p>
--

- **Search Results** – On clicking the **Search** button, the search results are filtered based on the specified search criteria. The **Search Results** section contains the following columns:

Column Name	Column Description
Pricing Information	Displays the concatenated string consisting of pricing information and pricing ID for the person.  <b>Note:</b> It has a link. On clicking the link, the <b>View Price Item Pricing</b> screen appears with the details of the respective price item pricing.
Price Item	Displays the price item or price item bundle code.
Pricing Parameters	Used to specify multiple parameters based on which you want to determine the pricing utilization.  <b>Note:</b> This column appears only when the <b>Multi Price Parameter</b> option type of the <b>Multi Parameter Based Pricing (C1_PPARM_FLG)</b> feature configuration is set to <b>True</b> .
Price Assignment Type	Indicates the type of price assignment. The valid values are: <ul style="list-style-type: none"> <li>• Regular</li> <li>• Post Processing</li> <li>• Post Processing – Invoice Based</li> <li>• Post Processing – Price Item Based</li> </ul>

Column Name	Column Description
Assignment Level	<p>Indicates the level at which the price item pricing is defined in the customer hierarchy. The valid values are:</p> <ul style="list-style-type: none"> <li>• Customer Agreed</li> <li>• Customer Price List</li> <li>• Customer Inherited Price List</li> <li>• Default Price List</li> <li>• Global Price List</li> <li>• Parent Customer Agreed</li> <li>• Parent Customer Price List</li> <li>• Parent Customer Inherited Price List</li> </ul>
Price List Information	Displays the information about the price list which is assigned to the account.
Rate Schedule	Indicates the rate schedule which is used for defining the price item pricing.
Edit	<p>On clicking the <b>Edit</b>  icon, the <b>Price Item Pricing</b> screen appears where you can edit the details of the price item pricing.</p> <p><b>Note:</b> The <b>Edit</b> icon appears only when the assignment level is <b>Customer Agreed</b>.</p>
Override	<p>On clicking the <b>Override</b>  icon, the <b>Price Item Pricing</b> screen appears where you can override the price item pricing.</p> <p><b>Note:</b></p> <p>You can override a price item pricing assigned at any level in the customer hierarchy. On overriding a price item pricing, a new price item pricing which is specific to the account is defined at the account level and is then called account agreed pricing.</p> <p>A customer agreed or account agreed price assignments are effective for a particular duration and do not expire until you specify the end date manually. However, if you set the <b>Expire Override Switch</b> option type of the <b>C1_EXP_OVRD</b> feature configuration to <b>Y</b>, the system will automatically expire an agreed pricing when the agreed pricing of a customer or an account without end date is overridden. If you do not want an agreed pricing to automatically expire when it is overridden, you must set the <b>Expire Override Switch</b> option type of the <b>C1_EXP_OVRD</b> feature configuration to <b>N</b>.</p>
Effective Start Date	Displays the date from when the price item pricing is effective.
Effective End Date	Displays the date till when the price item pricing is effective.
Pricing Currency	Indicates the currency in which the price item pricing is defined.
Parent Person	Displays the name of the parent or grandparent customer from whom the price item pricing is inherited.

**Note:** The number of records that can be displayed in the **Search Results** section is controlled via the **C1\_PR\_REC** feature configuration. You can change the number of records that can be displayed using the **Effective Pricing RecordSet Limit** option type of the **C1\_PR\_REC** feature configuration. For more information, refer to [Setting the C1\\_PR\\_REC Feature Configuration](#) on page 2924.

**Related Topics**

For more information on...	See...
How to view effective price assignments of a person	<a href="#">Viewing Effective Price Assignments of a Person</a> on page 484
How to override a price item pricing	<a href="#">Override Price Item Pricing</a>
How to edit a price item pricing	<a href="#">Editing a Price Item Pricing</a>
How to filter effective price assignments of a person	<a href="#">Filtering Effective Price Assignments of a Person</a> on page 485

**Search Price Item**

You can either assign a price item to a price list and then define pricing for the price item, or you can copy an existing price item pricing and assign it to a price list. The **Search Price Item** zone allows you to search for a price item pricing which is assigned to an account, person, or a price list. You can then create a new price item pricing using an existing price item pricing through copying the price item pricing. Once you create a copy of an existing price item pricing, the new price item pricing is assigned to the price list. On copying a price item pricing, the pricing details including the price components, eligibility and tiering criteria for each price component, and characteristics are copied to the new price item pricing. You can then edit the details, if required.

The system allows you to create a copy of active, proposed, inactive, rejected, and template price item pricing. Once you create the copy of a template price item pricing, you can save the new price item pricing in either **Active** or **Proposed** status.

The **Search Price Item** zone contains the following two sections:

- **Search Criteria** – The **Search Criteria** section contains the following fields:

Field Name	Field Description	Mandatory (Yes or No)
Search By	Used to search whether you want to search price item pricing for a price item, account, person, or a price list. The valid values are: <ul style="list-style-type: none"> <li>• Price Item</li> <li>• Price List Pricing</li> <li>• Account Override Pricing</li> <li>• Person Override Pricing</li> </ul>	Yes
Price Item	Used to search pricing for a particular price item or price item bundle.	No
Description	Used to search price items or price item bundles with a particular description. <div style="border: 1px solid black; padding: 2px; margin-top: 5px;"> <p><b>Note:</b> This field appears only when you select the <b>Price Item</b> option from the <b>Search By</b> list.</p> </div>	No

Field Name	Field Description	Mandatory (Yes or No)
Global Price List	<p>Used to search price items or price item bundles which can be assigned to a global price list. The valid values are:</p> <ul style="list-style-type: none"> <li>• Yes</li> <li>• No</li> </ul> <p><b>Note:</b> This field appears only when you select the <b>Price Item</b> option from the <b>Search By</b> list.</p>	No
Bundle	<p>Used to search whether the price item is a bundle or not. The valid values are:</p> <ul style="list-style-type: none"> <li>• Yes</li> <li>• No</li> </ul> <p><b>Note:</b> This field appears only when you select the <b>Price Item</b> option from the <b>Search By</b> list.</p>	No
Price List ID	<p>Used to search the price list to which the price item pricing is assigned.</p> <p><b>Note:</b> This field appears only when you select the <b>Price List Pricing</b> option from the <b>Search By</b> list.</p>	No
Effective Start Date	<p>Used to search price item pricing on price lists which are effective from a particular date onwards.</p> <p><b>Note:</b> This field appears only when you select the <b>Price List Pricing, Account Override Pricing, or Person Override Pricing</b> option from the <b>Search By</b> list.</p>	No
Effective End Date	<p>Used to search price item pricing on price lists which are effective till a particular date.</p> <p><b>Note:</b> This field appears only when you select the <b>Price List Pricing, Account Override Pricing, or Person Override Pricing</b> option from the <b>Search By</b> list.</p>	No



Field Name	Field Description	Mandatory (Yes or No)
Pricing Status	Used to search price item pricing with a particular status. The valid values are: <ul style="list-style-type: none"> <li>• Active</li> <li>• Inactive</li> <li>• Proposed</li> <li>• Rejected</li> <li>• Template</li> </ul> <div style="border: 1px solid black; padding: 5px; margin-top: 10px;"> <b>Note:</b> This field appears only when you select the <b>Price List Pricing, Account Override Pricing, or Person Override Pricing</b> option from the <b>Search By</b> list. </div>	No
Price Assignment Type	Used to search a particular type of the price item pricing. The valid values are: <ul style="list-style-type: none"> <li>• Regular</li> <li>• Post Processing</li> <li>• Post Processing – Invoice Based</li> <li>• Post Processing – Price Item Based</li> </ul> <div style="border: 1px solid black; padding: 5px; margin-top: 10px;"> <b>Note:</b> This field appears only when you select the <b>Price List Pricing, Account Override Pricing, or Person Override Pricing</b> option from the <b>Search By</b> list. </div>	No
Account ID	Used to search pricing of price items which are assigned to a particular account. <div style="border: 1px solid black; padding: 5px; margin-top: 10px;"> <b>Note:</b> This field appears only when you select the <b>Account Override Pricing</b> option from the <b>Search By</b> list. </div>	No
Person ID	Used to search pricing of price items which are assigned to a particular person. <div style="border: 1px solid black; padding: 5px; margin-top: 10px;"> <b>Note:</b> This field appears only when you select the <b>Person Override Pricing</b> option from the <b>Search By</b> list. </div>	No

**Note:**



You must specify at least one search criterion while searching for a price item or price item bundle.

The **Search**  icon appears corresponding to the **Price List ID, Price Item, Account ID, and Person ID** fields. On clicking the **Search** icon, you can search for a price list, price item, an account, and person.

- **Search Results** — On clicking the **Search** button, the search results appear based on the specified search criteria. The search results include only those price items or price item bundles that are associated with the division to which the person belongs. However, if the person does not belong to any division, the search will be performed

against all price items or price item bundles defined in the system. It may also include price items or price item bundles that are already assigned to the person in case those price items or price item bundles match the search criteria.

The **Search Results** section contains the following columns:

Column Name	Column Description
Assign	<p>On clicking the <b>Assign</b> () icon, the <b>Price Item Pricing</b> screen appears where you can define a new price item pricing.</p> <p><b>Note:</b> This column appears only when you select the <b>Price Item</b> option from the <b>Search By</b> list.</p>
Price Item Information	<p>Displays details of the price item or price item bundle.</p> <p><b>Note:</b> It has a link. On clicking the link, the <b>Price Item</b> screen appears where you can view the details of the respective price item or price item bundle. This column appears only when you select the <b>Price Item</b> option from the <b>Search By</b> list.</p>
Copy	<p>On clicking the <b>Copy</b> () icon, the <b>Price Item Pricing</b> screen appears where you can define a new price item pricing using an existing price item pricing.</p>
Pricing Information	<p>Displays details of the price item pricing.</p> <p><b>Note:</b> This column appears only when you select the <b>Price List Pricing, Account Override Pricing, or Person Override Pricing</b> option from the <b>Search By</b> list.</p>
Account Information	<p>Indicates the account to which the price item pricing is assigned. In addition, this column has a context menu which helps in navigating to other screens in the application.</p> <p><b>Note:</b> This column appears only when you select the <b>Account Override Pricing</b> option from the <b>Search By</b> list. It has a link. On clicking the link, the <b>Account</b> screen appears where you can view the details of the respective account. The account information string appears only when an algorithm defined using the <b>C1-AC-INFO</b> algorithm type is attached to the <b>Account Information</b> system event in the <b>Algorithms</b> tab of the <b>Installation Options – Framework</b> screen.</p>

Column Name	Column Description
Person Information	<p>Indicates the person to which the price item pricing is assigned. In addition, this column has a context menu which helps in navigating to other screens in the application.</p> <div data-bbox="570 323 1466 661" style="border: 1px solid black; padding: 5px;"> <p><b>Note:</b></p> <p>This column appears only when you select the <b>Person Override Pricing</b> option from the <b>Search By</b> list.</p> <p>It has a link. On clicking the link, the <b>Person</b> screen appears where you can view the details of the respective person.</p> <p>The person information string appears only when an algorithm defined using the <b>PERS-INFO</b> algorithm type is attached to the <b>Person Information</b> system event in the <b>Algorithms</b> tab of the <b>Installation Options – Framework</b> screen.</p> </div>
Price List Information	<p>Indicates the price list to which the price item pricing is assigned. In addition, this column has a context menu which helps in navigating to other screens in the application.</p> <div data-bbox="570 800 1466 1024" style="border: 1px solid black; padding: 5px;"> <p><b>Note:</b></p> <p>This column appears only when you select the <b>Price List Pricing</b> option from the <b>Search By</b> list.</p> <p>It has a link. On clicking the link, the <b>Price List</b> screen appears where you can view the details of the respective price list.</p> </div>
Pricing Parameters	<p>Displays a comma-separated list of parameter values. The order in which parameter values appear in this column is controlled by the display order (which is defined while associating a parameter with a price item or price item bundle).</p> <div data-bbox="570 1167 1466 1278" style="border: 1px solid black; padding: 5px;"> <p><b>Note:</b> This column appears only when the <b>Multi Price Parameter</b> option type of the <b>Multi Parameter Based Pricing (C1_PPARM_FLG)</b> feature configuration is set to <b>False</b>.</p> </div>
Effective Start Date	<p>Displays the date from when the price item pricing is effective.</p> <div data-bbox="570 1356 1466 1438" style="border: 1px solid black; padding: 5px;"> <p><b>Note:</b> This column appears only when you select the <b>Price List Pricing, Account Override Pricing, or Person Override Pricing</b> option from the <b>Search By</b> list.</p> </div>
Effective End Date	<p>Displays the date till when the price item pricing is effective.</p> <div data-bbox="570 1514 1466 1596" style="border: 1px solid black; padding: 5px;"> <p><b>Note:</b> This column appears only when you select the <b>Price List Pricing, Account Override Pricing, or Person Override Pricing</b> option from the <b>Search By</b> list.</p> </div>
Pricing Currency	<p>Indicates the currency in which the price item pricing is defined.</p> <div data-bbox="570 1671 1466 1753" style="border: 1px solid black; padding: 5px;"> <p><b>Note:</b> This column appears only when you select the <b>Price List Pricing, Account Override Pricing, or Person Override Pricing</b> option from the <b>Search By</b> list.</p> </div>

Column Name	Column Description
Rate Schedule	<p>Indicates the rate schedule which is used for defining the price item pricing.</p> <p><b>Note:</b> It has a link. On clicking the link <b>Rate Schedule</b> screen appears. This column appears only when you select the <b>Price List Pricing, Account Override Pricing, or Person Override Pricing</b> option from the <b>Search By</b> list.</p>
Price Assignment Usage	<p>Indicates whether the price item pricing is applicable to all customers or only to new customers. The valid values are:</p> <ul style="list-style-type: none"> <li>• All Customers</li> <li>• New Customers</li> </ul> <p><b>Note:</b> This column appears only when you select the <b>Price List Pricing, Account Override Pricing, or Person Override Pricing</b> option from the <b>Search By</b> list.</p>
Price Assignment Type	<p>Indicates the type of the price item pricing. The valid values are:</p> <ul style="list-style-type: none"> <li>• Regular</li> <li>• Post Processing</li> <li>• Post Processing – Invoice Based</li> <li>• Post Processing – Price Item Based</li> </ul> <p><b>Note:</b> This column appears only when the <b>Multi Price Parameter</b> option type of the <b>Multi Parameter Based Pricing (C1_PPARM_FLG)</b> feature configuration is set to <b>False</b>.</p>

### Related Topics

For more information on...	See...
How to copy a price item pricing	<a href="#">Copying a Price Item Pricing</a> on page 489
How to assign a price item or price item bundle to a person	<a href="#">Assigning a Price Item or Price Item Bundle to a Person</a>

## Viewing Effective Price Assignments of a Person

### Prerequisites

To view effective price assignments of a person, you should have:

- Price items or price item bundles assigned to the person either directly or through the customer hierarchy

### Procedure

To view effective price assignments of a person:

1. Search for the person in the **Customer 360° View** screen.
2. In the **Search Results** section, click the **Show Context Menu** () icon corresponding to the person whose details you want to view.  
A menu appears.
3. Click the **Go To Effective Pricing** menu option.

The **Pricing (Person)** screen appears.

4. View the pricing for price items or price item bundles assigned to the person (either directly or through the customer hierarchy) in the **Effective Price Assignments for Person** zone.
5. Filter the effective price assignments of the person, if required.

### Related Topics

For more information on...	See...
How to search for a person	<a href="#">Searching for a Person</a> on page 185
<b>Pricing (Person)</b> screen	<a href="#">Pricing (Person)</a> on page 473
<b>Effective Price Assignments for Person</b> zone	<a href="#">Effective Price Assignments for Person</a> on page 474
How to filter effective price assignments of a person	<a href="#">Filtering Effective Price Assignments of a Person</a> on page 485

## Filtering Effective Price Assignments of a Person

### Prerequisites

To filter effective price assignments of a person, you should have:

- Price items or price item bundles defined in the application
- Parameters defined in the application (where the source entity is set to **Transaction**)
- Price items or price item bundles assigned to the person either directly or through the customer hierarchy

### Procedure

To filter effective price assignments of a person:

1. Search for the person in the **Customer 360° View** screen.
2. In the **Search Results** section, click the **Show Context Menu** () icon corresponding to the person whose details you want to view.  
A menu appears.
3. Click the **Go To Effective Pricing** menu option.  
The **Pricing (Person)** screen appears.
4. Enter the search criteria in the **Effective Price Assignments for Person** zone.

**Note:**

You can search for a price item, parameter, or parameter value by clicking the **Search**  icon corresponding to the respective field.

If you want to add more than one parameter in the search criteria, click the **Add**  icon and then enter the parameter name and its value. However, if you want to remove a parameter from the search criteria, click the

**Delete**  icon corresponding to the parameter.

You can only use those parameters where the source entity is set to **Transaction**.

ORMB search engine supports wildcard search, where you can substitute the percentage (%) symbol as a stand in for any word or letter in a search criteria. You can use the ‘%’ wildcard character in all input fields except the date and ID fields. The ‘%’ wildcard character is suffixed automatically at the end of the partial search criteria. Therefore, you may or may not specify the wildcard character at the end of the partial search criteria. However, you have to prefix the wildcard character manually wherever required.

### 5. Click **Search**.

A list of price assignments which are effective on the specified date and that meet the search criteria are listed in the **Effective Price Assignments for Person** zone.

#### Related Topics

For more information on...	See...
How to search for a person	<a href="#">Searching for a Person</a> on page 185
<b>Pricing (Person)</b> screen	<a href="#">Pricing (Person)</a> on page 473
<b>Effective Price Assignments for Person</b> zone	<a href="#">Effective Price Assignments for Person</a> on page 474

## Exporting Effective Price Assignments of a Person

### Prerequisites

To export effective price assignments of a person in the CSV format, you should have:

- Price items or price item bundles assigned to the person either directly or through the customer hierarchy

### Procedure

To export effective price assignments of a person in the CSV format:

1. Search for the person in the **Customer 360° View** screen.
2. In the **Search Results** section, click the **Show Context Menu**  icon corresponding to the person whose details you want to view.  
A menu appears.
3. Click the **Go To Effective Pricing** menu option.  
The **Pricing (Person)** screen appears.
4. Filter the effective price assignments of the person, if required.
5. Click the **Export to Excel** link in the **Effective Price Assignment** zone.  
A message appears confirming whether you want to open or save the EffectivePricing.csv file.
6. Select the **Save As** option from the **Save** list.  
The **Save As** dialog box appears.

7. Browse to the location where you want to save the file.
8. Enter the file name in the respective field, and click **Save**.

The search results are exported in the CSV format.

9. Open the CSV file in Microsoft Excel.

The sheet contains the following columns:

Column Name	Column Description
Price Item	Displays the price item or price item bundle code.
Description	Displays the description of the price item or price item bundle.
Variance	Indicates the variance parameter which is used for defining the price item pricing.  <b>Note:</b> This column appears only when the <b>Multi Price Parameter</b> option type of the <b>Multi Parameter Based Pricing (C1_PPARM_FLG)</b> feature configuration is set to <b>False</b> .
Price Item Parameters	Displays a comma-separated list of parameter values. The order in which parameter values appear in this column is controlled by the display order (which is defined while associating a parameter with a price item). A tool tip appears when you hover over this column corresponding to the price item. It indicates the price item parameters and their values which are used for defining the price item pricing.  <b>Note:</b> This column appears only when the <b>Multi Price Parameter</b> option type of the <b>Multi Parameter Based Pricing (C1_PPARM_FLG)</b> feature configuration is set to <b>True</b> .
Price Assignment Type	Indicates the type of price assignment. The valid values are: <ul style="list-style-type: none"> <li>• Regular</li> <li>• Post Processing</li> <li>• Post Processing – Invoice Based</li> <li>• Post Processing – Price Item Based</li> </ul>
Assignment Level	Indicates the level at which the price item pricing is defined in the customer hierarchy. The valid values are: <ul style="list-style-type: none"> <li>• Customer Agreed</li> <li>• Customer Price List</li> <li>• Customer Inherited Price List</li> <li>• Parent Customer Agreed</li> <li>• Parent Customer Price List</li> <li>• Parent Customer Inherited Price List</li> </ul>
Price List Description	Displays the description of the price list.  <b>Note:</b> The description appears only when the assignment level is <b>Customer Price List, Customer Inherited Price List, Parent Customer Price List, or Parent Customer Inherited Price List</b> .

Column Name	Column Description
Rate Description	Displays the description of the rate schedule which is used for defining the price item pricing.
Rate Component Information	Displays a comma-separated string which consists of the following: <ul style="list-style-type: none"> <li>• Rate Component Sequence</li> <li>• Tiering Setup of the Rate Component</li> </ul>
Price Component Sequence	Indicates the sequence number of the price component.
Price Component Description	Displays the description of the price component.
Rate	Indicates the rate defined for the price component.
Effective Start Date	Displays the date from when the price item pricing is effective.
Effective End Date	Displays the date till when the price item pricing is effective.
Pricing Currency	Indicates the currency in which the price item pricing is defined.
From	Displays the lower limit of the tiering range.
To	Displays the upper limit of the tiering range.
Price Assignment Usage	Indicates whether the price item pricing is applicable to all customers or only to the new customers. The valid values are: <ul style="list-style-type: none"> <li>• AC</li> <li>• NC</li> </ul>
Price Assignment ID	Displays the price assignment ID.
Parent Level	Indicates the numerical level of the parent in the customer hierarchy from whom the price item pricing is inherited.
Price List ID	Indicates the price list from where the price item pricing is inherited.
Price List Start Date	Displays the date from when the price list is effective.
Parent Person	Displays the name of the parent or grandparent customer from whom the price item pricing is inherited.
Parent Pricelist Level	Indicates the parent level when price item pricing is inherited from the price list hierarchy. If the pricing is inherited from the assigned price list, the parent price list level will be 0. However, if the pricing is inherited from the parent price list in the hierarchy, the parent price list level will be 1. And, if the pricing is inherited from the grandparent price list in the hierarchy, the parent price list level will be 2, and so on.
Ignore Transaction	Indicates whether the transactions mapped to the price item is considered for billing. The valid values are: <ul style="list-style-type: none"> <li>• Y</li> <li>• N</li> </ul>



Column Name	Column Description
Aggregate Transaction	Indicates whether the transactions mapped to the price item is aggregated for billing. The valid values are: <ul style="list-style-type: none"> <li>• Y</li> <li>• N</li> </ul>
Aggregation Schedule	Indicates the transaction aggregation cycle. The valid values are: <ul style="list-style-type: none"> <li>• Daily</li> <li>• Weekly</li> <li>• Monthly</li> <li>• Quarterly</li> <li>• Yearly</li> </ul>
Tiering Criterion	Indicates the tiering criterion which is used in the tiering range.
Tiering Price Item	Indicates whether the price item or price item bundle's total usage is considered for determining the rate.

### **Related Topics**

For more information on...	See...
<b>Pricing (Person)</b> screen	<a href="#">Pricing (Person)</a> on page 473
<b>Effective Price Assignment</b> zone	<a href="#">Effective Price Assignments for Person</a> on page 474
How to search for a person	<a href="#">Searching for a Person</a>

## **Copying a Price Item Pricing**

### **Prerequisites**

To copy a price item pricing and assign it to a person, you should have:

- Person (to which you want to assign the price item pricing) defined in the application
- Person associated with the division to which the user belongs
- Price item pricing (whose copy you want to create) defined in the application

### **Procedure**

To copy a price item pricing and assign it to a person:

1. Search for the person in the **Customer 360° View** screen.
2. In the **Search Results** section, click the **Show Context Menu** () icon corresponding to the person whose details you want to view.  
A menu appears.
3. Click the **Go To Effective Pricing** menu option.  
The **Pricing (Person)** screen appears.
4. In the **Search Price Item** zone, select the required option from the **Search By** list to indicate whether you want to search price item pricing assigned to an account, person, or a price list.

The fields in the **Search Criteria** section change depending on the option that you select from the **Search By** list.

5. Enter the search criteria in the **Search Price Item** zone to search for the price item pricing whose copy you want to create and assign it to the person.
6. Click **Search**.

A list of price assignments that meet the search criteria appears in the **Search Results** section.

7. In the **Search Results** section, click the **Copy** () icon in the **Copy** column corresponding to the price item pricing whose copy you want to create.

The **Price Item Pricing** screen appears.

8. Modify the required pricing details.

**Note:**

If you change the effective start and end dates while copying a price item pricing, you need to specify the parameters which are effective during that date range.

While copying a price item pricing, you can not only edit the existing tiering combination details, but can also add additional tiering combinations until the maximum tiering combinations limit is met.

If you are creating a copy of active, proposed, inactive, rejected, or template price item pricing, you can save the new price item pricing in the **Active** or **Proposed** status.

9. Edit the characteristics of the price item pricing, if required.

10. Click **Save**.

A new price item pricing is defined and assigned to the person.

### **Related Topics**

<b>For more information on...</b>	<b>See...</b>
How to search for a person	<a href="#">Searching for a Person</a> on page 185
<b>Pricing (Person)</b> screen	<a href="#">Pricing (Person)</a> on page 473
<b>Search Price Item</b> zone	<a href="#">Search Price Item</a> on page 479
How to edit a price item pricing	<a href="#">Editing a Price Item Pricing</a>
How to edit characteristics of a price item pricing	<a href="#">Editing the Price Item Pricing Characteristics</a>

## **Viewing a Price Item Pricing**

### **Procedure**

To view a price item pricing and assignment details:

1. Search for the person in the **Customer 360° View** screen.
2. In the **Search Results** section, click the **Show Context Menu** () icon corresponding to the person whose details you want to view.  
A menu appears.
3. Click the **Go To Effective Pricing** menu option.  
The **Pricing (Person)** screen appears.
4. Price assignments effective for the person appears in the **Effective Price Assignments for Person** zone.

5. In the **Search Results** section, click the link in the **Pricing Information** column corresponding to the price item whose pricing details you want to view.

The **Price Item Pricing** screen appears. It contains the following zones:

- **Price Item Pricing** – Displays the price item pricing details. It contains the following sections:
  - **Pricing Information** – Displays the pricing information of the price item.
  - **TFM Information** – Displays the transaction feed management information of the price item.
  - **Characteristics** – Displays the details of price item pricing characteristics.
  - **Price Item and Parameter Information** – Displays the price item parameter details.
  - **Record Actions** – Displays the record actions of the price item pricing.
  - **Record Information** – Displays the record information of the price item pricing.
- **Rate and Price Component Summary** – Displays the rate and price component summary of the price item.
- **Rate Components** – Displays the rate components of the price item.
- **Price Components** – Displays the details of price components of the price item.
- **Tiering Criteria** – Displays the tiering criteria of the price item pricing.

**Note:** This zone appears only when **Tiering Type** for the rate component is **STEP** or **Threshold**

- **Pricing Eligibility Criteria** – Displays the pricing eligibility criteria of the price item pricing.

**Note:** This zone appears only when eligibility checkbox is selected in the **Price Item Pricing** screen and details for pricing eligibility criteria is added in the **Price Component** screen.

6. View the basic details of price item pricing in the **Price Item Pricing** zone.
7. View the rate and price component summary of price item in the **Rate and Price Component Summary** zone.
8. View the rate components of price item in the **Rate Components** zone.
9. View the details of price components of price item in the **Price Components** zone.
10. View the tiering criteria of price item pricing in the **Tiering Criteria** zone.
11. View the pricing eligibility criteria of price item pricing in the **Pricing Eligibility Criteria** zone.

### **Related Topics**

<b>For more information on...</b>	<b>See...</b>
How to search for a person	<a href="#">Searching for a Person</a> on page 185
<b>Pricing (Person)</b> screen	<a href="#">Pricing (Person)</a> on page 473
<b>Effective Price Assignments for Account</b> zone	<a href="#">Effective Price Assignments for Person</a> on page 474
<b>Price Item Pricing</b> screen	<a href="#">Price Item Pricing (Used for Viewing)</a> on page 507
<b>Price Item Pricing</b> zone	<a href="#">Price Item Pricing</a> on page 508
<b>Rate and Price Component Summary</b> zone	<a href="#">Rate and Price Component Summary</a> on page 511
<b>Rate Components</b> zone	<a href="#">Rate Components</a> on page 512
<b>Price Components</b> zone	<a href="#">Price Components</a> on page 512
<b>Tiering Criteria</b> zone	<a href="#">Tiering Criteria</a> on page 514
<b>Pricing Eligibility Criteria</b> zone	<a href="#">Pricing Eligibility Criteria</a> on page 514

## Editing a Price Item Pricing of a Person

### Prerequisites

To edit a price item pricing of a person, you should have:

- Transactions mapped to the price item defined in the application
- Rate schedules, rate versions, rate components defined in the application
- Parameters associated with the price item (in case you want to define price item pricing based on those parameters)

### Procedure

To edit a price item pricing of a person:

1. Search for the account in the **Customer 360° View** screen.
2. In the **Search Results** section, click the **Show Context Menu** (☰) icon corresponding to the person whose details you want to view.

A menu appears.

3. Click the **Go To Effective Pricing** menu option.

The **Pricing (Person)** screen appears.

4. Price assignments effective for the person appears in the **Effective Price Assignments for Person** zone.

5. In the **Search Results** section, click the **Edit** (✎) icon in the **Edit** column corresponding to the price item pricing whose details you want to edit.

The **Price Item Pricing** screen appears. It contains the following sections:

- **Main** – Used to specify basic details about the price item pricing.
- **TFM Information** – Used to specify the transaction feed management information about the price item pricing.

**Note:** This section appears in the **Price Item Pricing** screen only when the value for the **Show Default Values in Price Item Pricing** option type for **C1\_FM** feature configuration is set to **Y** and **Price Item Available For** is **Pricing and Billing**.

- **Characteristics** – Used to define characteristics for the price item pricing.
- **Price Item and Parameter Information** – Used to define the parameter details segment for the price item pricing.

**Note:** This section appears only when **Price Assignment Type** is **Regular**.

The **Main** section contains the following fields:

Field Name	Field Description	Mandatory (Yes or No)
Start Date	<p>Used to specify the date from when the price item pricing is effective.</p> <div data-bbox="548 289 1105 659" style="border: 1px solid black; padding: 5px;"> <p><b>Note:</b></p> <p>The effective start date cannot be later than the effective end date.</p> <p>If you change the effective start and end dates while editing a price item pricing, you need to specify the parameters which are effective during that date range.</p> <p>This field will be in read-only mode when the price assignment has been used.</p> </div>	Yes
End Date	<p>Used to specify the date till when the price item pricing is effective.</p> <div data-bbox="548 768 1105 848" style="border: 1px solid black; padding: 5px;"> <p><b>Note:</b> The effective end date cannot be earlier than the effective start date.</p> </div>	No

Field Name	Field Description	Mandatory (Yes or No)
Price Assignment Type	<p>Used to indicate the type of price assignment. The valid values are:</p> <ul style="list-style-type: none"> <li>• <b>Regular</b> – Used to indicate that the pricing must be used to generate regular bill segment.</li> <li>• <b>Post Processing</b> – Used to indicate that the pricing must be used to generate post processing bill segment. This type of price assignment can be done on usage accounts. The post processing bill segment is generated when you generate the bill for the usage account and not when you bill the usage account through an invoice account.</li> </ul> <div data-bbox="613 640 1109 913" style="border: 1px solid black; padding: 5px;"> <p><b>Note:</b> The post processing bill segment is generated when the <b>Post Processing Sequence (PPSEQ)</b> characteristic is defined for the price item and when the price item is associated with another price item using the <b>Price Item</b> relationship type.</p> </div> <ul style="list-style-type: none"> <li>• <b>Post Processing – Invoice Based</b> – Used to indicate that the pricing must be used to generate post processing bill segment. This type of price assignment can be done on an invoice account, and, as a result, the post processing bill segment is generated on the invoice account.</li> </ul> <div data-bbox="613 1171 1109 1255" style="border: 1px solid black; padding: 5px;"> <p><b>Note:</b> This will not be applicable for price item which are defined for <b>Only Pricing</b>.</p> </div> <ul style="list-style-type: none"> <li>• <b>Post Processing – Price Item Based</b> – Used to indicate that the pricing must be used to generate post processing bill segment. This type of price assignment can be done on both invoice and usage accounts, but the post processing bill segment is generated only on the invoice account.</li> </ul> <div data-bbox="613 1514 1109 1598" style="border: 1px solid black; padding: 5px;"> <p><b>Note:</b> This will not be applicable for price item which are defined for <b>Only Pricing</b>.</p> </div>	Yes
Pricing Eligibility	<p>Used to select pricing eligibility criteria for price item pricing.</p> <div data-bbox="548 1703 1109 1818" style="border: 1px solid black; padding: 5px;"> <p><b>Note:</b> This field will be enabled for selection if the checkbox is not selected. If the checkbox appears selected then this field will be in read-only mode.</p> </div>	No

Field Name	Field Description	Mandatory (Yes or No)
Pricing Status	<p>Used to indicate the status of the price assignment. The valid values are:</p> <ul style="list-style-type: none"> <li>• <b>Draft</b> – Indicates that the price assignment is created as a draft.</li> <li>• <b>Active</b> – Indicates that the price assignment is used for billing.</li> <li>• <b>Inactive</b> – Indicates that the price assignment is no longer used for billing.</li> <li>• <b>Proposed</b> – Indicates that the price assignment is used for quotations.</li> </ul> <div data-bbox="548 611 1105 835" style="border: 1px solid black; padding: 5px;"> <p><b>Note:</b> If a price assignment is in <b>Active</b> status, you can change its status to <b>Inactive</b>. If a price assignment is in <b>Draft</b> status, you cannot change its status to <b>Proposed</b>.</p> </div>	Yes
Pricing Currency	Used to indicate the currency in which you want to define the price item pricing.	Yes
Rate Schedule	<p>Used to specify the rate schedule that you want to use while defining price item pricing.</p> <div data-bbox="548 1024 1105 1293" style="border: 1px solid black; padding: 5px;"> <p><b>Note:</b> Rate schedules control how the bills for the price item will be calculated. The <b>Search</b> (🔍) icon appears corresponding to this field. On clicking the <b>Search</b> icon, the <b>Rate Schedule Search</b> screen appears.</p> </div>	Yes
Pricing Rule Type	<p>Used to indicate the pricing rule type. The valid value is:</p> <ul style="list-style-type: none"> <li>• Two-Dimensional</li> </ul>	Yes (Conditional) <div data-bbox="1128 1367 1466 1482" style="border: 1px solid black; padding: 5px;"> <p><b>Note:</b> This field is required when you are editing a two-dimensional pricing rule.</p> </div>
Print Zero	<p>Used to indicate whether zero pricing should be displayed in the bill. The valid values are:</p> <ul style="list-style-type: none"> <li>• Yes</li> <li>• No</li> </ul> <div data-bbox="548 1686 1105 1738" style="border: 1px solid black; padding: 5px;"> <p><b>Note:</b> By default, <b>Yes</b> is selected.</p> </div>	Yes
Pricing Frequency	<div data-bbox="548 1812 1105 1927" style="border: 1px solid black; padding: 5px;"> <p><b>Note:</b> This field appears only when <b>Price Item</b> is defined as <b>Only Pricing</b> and <b>Price Item Type</b> is defined as <b>Fees</b>.</p> </div>	Yes

6. Modify the details in the **Main** section, if required.
7. Edit the TFM Information in a price item pricing, if required.
8. Edit the characteristics for a price item pricing, if required.
9. Edit the parameters for a price item pricing, if required.
10. Click **Save**.

The changes made to the price item pricing are saved.

### Related Topics

For more information on...	See...
How to search for a person	<a href="#">Searching for a Person</a> on page 185
<b>Pricing (Person)</b> screen	<a href="#">Pricing (Person)</a> on page 473
<b>Effective Price Assignments for Person</b> zone	<a href="#">Effective Price Assignments for Person</a> on page 474
How to define a price item pricing.	<a href="#">Defining a Price Item Pricing</a> on page 516
How to define characteristics for a price item pricing.	<a href="#">Defining Characteristics for a Price Item Pricing</a> on page 405
How to define parameters for a price item pricing.	<a href="#">Defining Parameters for a Price Item Pricing</a> on page 406
How to define TFM Information in a price item pricing.	<a href="#">Defining TFM Information in a Price Item Pricing</a> on page 407

## Overriding a Price Item Pricing of a Person



### Prerequisites

To override a price item pricing of a person, you should have:

- Transactions mapped to the price item defined in the application
- Rate schedules, rate versions, rate components defined in the application
- Parameters associated with the price item (in case you want to define price item pricing based on multiple parameters)

### Procedure

To override a price item pricing of a person:

1. Search for the person in the **Customer 360° View** screen.
2. In the **Search Results** section, click the **Show Context Menu** () icon corresponding to the person whose details you want to view.  
A menu appears.
3. Click the **Go To Effective Pricing** menu option.  
The **Pricing (Person)** screen appears.
4. Price assignments effective for the person appears in the **Effective Price Assignments for Person** zone.
5. In the **Search Results** section, click the **Override** () icon in the **Override** column corresponding to the price item pricing whose details you want to override.

The **Price Item Pricing** screen appears. It contains the following sections:

- **Main** – Used to specify basic details about the price item pricing.



- **TFM Information** – Used to specify the transaction feed management information about the price item pricing.

**Note:** This section appears in the **Price Item Pricing** screen only when the value for the **Show Default Values in Price Item Pricing** option type for **C1\_FM** feature configuration is set to **Y** and **Price Item Available For** is **Pricing and Billing**.

- **Characteristics** – Used to define characteristics for the price item pricing.
- **Price Item and Parameter Information** – Used to define the parameter details segment for the price item pricing.

**Note:** This section appears only when **Price Assignment Type** is **Regular**.

The **Main** section contains the following fields:

Field Name	Field Description	Mandatory (Yes or No)
Start Date	Used to specify the date from when the price item pricing is effective.  <b>Note:</b> The effective start date cannot be later than the effective end date. If you change the effective start and end dates while overriding a price item pricing, you need to specify the parameters which are effective during that date range. This field will be in read-only mode when the price assignment has been used.	Yes
End Date	Used to specify the date till when the price item pricing is effective.  <b>Note:</b> The effective end date cannot be earlier than the effective start date.	No

Field Name	Field Description	Mandatory (Yes or No)
Price Assignment Type	<p>Used to indicate the type of price assignment. The valid values are:</p> <ul style="list-style-type: none"> <li>• <b>Regular</b> – Used to indicate that the pricing must be used to generate regular bill segment.</li> <li>• <b>Post Processing</b> – Used to indicate that the pricing must be used to generate post processing bill segment. This type of price assignment can be done on usage accounts. The post processing bill segment is generated when you generate the bill for the usage account and not when you bill the usage account through an invoice account.</li> </ul> <div data-bbox="613 640 1109 913" style="border: 1px solid black; padding: 5px;"> <p><b>Note:</b> The post processing bill segment is generated when the <b>Post Processing Sequence (PPSEQ)</b> characteristic is defined for the price item and when the price item is associated with another price item using the <b>Price Item</b> relationship type.</p> </div> <ul style="list-style-type: none"> <li>• <b>Post Processing – Invoice Based</b> – Used to indicate that the pricing must be used to generate post processing bill segment. This type of price assignment can be done on an invoice account, and, as a result, the post processing bill segment is generated on the invoice account.</li> </ul> <div data-bbox="613 1171 1109 1255" style="border: 1px solid black; padding: 5px;"> <p><b>Note:</b> This will not be applicable for price item which are defined for <b>Only Pricing</b>.</p> </div> <ul style="list-style-type: none"> <li>• <b>Post Processing – Price Item Based</b> – Used to indicate that the pricing must be used to generate post processing bill segment. This type of price assignment can be done on both invoice and usage accounts, but the post processing bill segment is generated only on the invoice account.</li> </ul> <div data-bbox="613 1514 1109 1598" style="border: 1px solid black; padding: 5px;"> <p><b>Note:</b> This will not be applicable for price item which are defined for <b>Only Pricing</b>.</p> </div>	Yes
Pricing Eligibility	<p>Used to select pricing eligibility criteria for price item pricing.</p> <div data-bbox="548 1703 1109 1818" style="border: 1px solid black; padding: 5px;"> <p><b>Note:</b> This field will be in enabled for selection if the checkbox is not selected. If the checkbox appears selected then this field will be in read-only mode.</p> </div>	No

Field Name	Field Description	Mandatory (Yes or No)
Pricing Status	Used to indicate the status of the price assignment. The valid values are: <ul style="list-style-type: none"> <li>• <b>Draft</b> – Indicates that the price assignment is created as a draft.</li> <li>• <b>Proposed</b> – Indicates that the price assignment is used for quotations.</li> </ul> <div style="border: 1px solid black; padding: 2px;"><b>Note:</b> If a price assignment is in <b>Draft</b> status, you cannot change its status to <b>Proposed</b>.</div>	Yes
Pricing Currency	Used to indicate the currency in which you want to override the price item pricing.	Yes
Rate Schedule	Used to specify the rate schedule that you want to use while defining price item pricing. <div style="border: 1px solid black; padding: 2px;"><b>Note:</b> Rate schedules control how the bills for the price item will be calculated. The <b>Search</b> (🔍) icon appears corresponding to this field. On clicking the <b>Search</b> icon, the <b>Rate Schedule Search</b> screen appears.</div>	Yes
Pricing Rule Type	Used to indicate the pricing rule type. The valid value is: <ul style="list-style-type: none"> <li>• Two-Dimensional</li> </ul>	Yes (Conditional) <div style="border: 1px solid black; padding: 2px;"><b>Note:</b> This field is required when you are overriding a two-dimensional pricing rule.</div>
Print Zero	Used to indicate whether zero pricing should be displayed in the bill. The valid values are: <ul style="list-style-type: none"> <li>• Yes</li> <li>• No</li> </ul> <div style="border: 1px solid black; padding: 2px;"><b>Note:</b> By default, <b>Yes</b> is selected.</div>	Yes
Pricing Frequency	Used to indicate pricing frequency for the price item. <div style="border: 1px solid black; padding: 2px;"><b>Note:</b> This field appears only when <b>Price Item</b> is defined as <b>Only Pricing</b> and <b>Price Item Type</b> is defined as <b>Fees</b>.</div>	Yes

6. Modify the details in the **Main** section, if required.
7. Modify the TFM Information in a price item pricing, if required.
8. Modify the characteristics for a price item pricing, if required.
9. Modify the parameters for a price item pricing, if required.

**Note:** If you change the effective end date while overriding a price item pricing, you need to specify the parameters which are effective during the date range of start and end date.

**10. Click Save.**

The price item pricing is overridden.

**Related Topics**

For more information on...	See...
<b>Pricing (Person)</b> screen	<a href="#">Pricing (Person)</a> on page 473
<b>Effective Price Assignments for Person</b> zone	<a href="#">Effective Price Assignments for Person</a> on page 474
How to search for a person	<a href="#">Searching for a Person</a> on page 185
How to define a price item pricing	<a href="#">Defining a Price Item Pricing</a> on page 516
How to define characteristics for a price item pricing	<a href="#">Defining Characteristics for a Price Item Pricing</a> on page 405
How to define parameters for a price item pricing	<a href="#">Defining Parameters for a Price Item Pricing</a> on page 406
How to define TFM Information in a price item pricing	<a href="#">Defining TFM Information in a Price Item Pricing</a> on page 407



**Assigning a Price Item to a Person****Prerequisites**

To assign a price item to a person, you should have:

- Transactions mapped to the price item defined in the application
- Rate schedules, rate versions, and rate components defined in the application
- Parameters associated with the price item (in case you want to define price item pricing based on multiple parameters)

**Procedure**

To assign a price item to a person:

1. Search for the account in the **Customer 360° View** screen.
2. In the **Search Results** section, click the **Show Context Menu** () icon corresponding to the person whose details you want to view.  
A menu appears.
3. Click the **Go To Effective Pricing** menu option.  
The **Pricing (Person)** screen appears.
4. Search for the price item that you want to assign to the person in the **Search Price Item or Price Item Pricing** zone.
5. In the **Search Results** section, click the **Assign** () icon in the **Assign** column corresponding to the price item that you want to assign to the person.

The **Price Item Pricing** screen appears. It contains the following sections:

- **Main** – Used to specify basic details about the price item pricing.
- **TFM Information** – Used to specify the transaction feed management information about the price item pricing.

**Note:** This section appears in the **Price Item Pricing** screen only when the value for the **Show Default Values in Price Item Pricing** option type for **C1\_FM** feature configuration is set to **Y** and **Price Item Available For** is **Pricing and Billing**.

- **Characteristics** – Used to define characteristics for the price item pricing.
- **Price Item and Parameter Information** – Used to define the parameter details segment for the price item pricing.

**Note:** This section appears only when **Price Assignment Type** is **Processing**.

The **Main** section contains the following fields:

Field Name	Field Description	Mandatory (Yes or No)
Start Date	Used to specify the date from when the price item pricing is effective.  <b>Note:</b> By default, the current system date appears in this field. The effective start date cannot be later than the effective end date.	Yes
End Date	Used to specify the date till when the price item pricing is effective.  <b>Note:</b> The effective end date cannot be earlier than the effective start date.	No

Field Name	Field Description	Mandatory (Yes or No)
Price Assignment Type	<p>Used to indicate the type of price assignment. The valid values are:</p> <ul style="list-style-type: none"> <li>• <b>Regular</b> – Used to indicate that the pricing must be used to generate regular bill segment.</li> <li>• <b>Post Processing</b> – Used to indicate that the pricing must be used to generate post processing bill segment. This type of price assignment can be done on usage accounts. The post processing bill segment is generated when you generate the bill for the usage account and not when you bill the usage account through an invoice account.</li> </ul> <div data-bbox="613 611 1162 852" style="border: 1px solid black; padding: 5px;"> <p><b>Note:</b> The post processing bill segment is generated when the <b>Post Processing Sequence (PPSEQ)</b> characteristic is defined for the price item and when the price item is associated with another price item using the <b>Price Item</b> relationship type.</p> </div> <ul style="list-style-type: none"> <li>• <b>Post Processing – Invoice Based</b> – Used to indicate that the pricing must be used to generate post processing bill segment. This type of price assignment can be done on an invoice account, and, as a result, the post processing bill segment is generated on the invoice account.</li> </ul> <div data-bbox="613 1077 1162 1157" style="border: 1px solid black; padding: 5px;"> <p><b>Note:</b> This will not be applicable for price item which are defined for <b>Only Pricing</b>.</p> </div> <ul style="list-style-type: none"> <li>• <b>Post Processing – Price Item Based</b> – Used to indicate that the pricing must be used to generate post processing bill segment. This type of price assignment can be done on both invoice and usage accounts, but the post processing bill segment is generated only on the invoice account.</li> </ul> <div data-bbox="613 1388 1162 1467" style="border: 1px solid black; padding: 5px;"> <p><b>Note:</b> This will not be applicable for price item which are defined for <b>Only Pricing</b>.</p> </div>	Yes
Pricing Eligibility	Used to select pricing eligibility criteria for price item pricing.	No
Pricing Status	<p>Used to indicate the status of the price assignment. The valid values are:</p> <ul style="list-style-type: none"> <li>• <b>Draft</b> – Indicates that the price assignment is created as a draft.</li> <li>• <b>Proposed</b> – Indicates that the price assignment is used for quotations.</li> </ul>	Yes
Pricing Currency	Used to indicate the currency in which you want to define the price item pricing.	Yes

Field Name	Field Description	Mandatory (Yes or No)
Rate Schedule	Used to specify the rate schedule that you want to use while defining price item pricing.  <b>Note:</b> Rate schedules control how the bills for the price item will be calculated.  The <b>Search</b> (🔍) icon appears corresponding to this field. On clicking the <b>Search</b> icon, the <b>Rate Schedule Search</b> screen appears.	Yes
Pricing Rule Type	Used to indicate the pricing rule type. The valid value is: <ul style="list-style-type: none"> <li>Two-Dimensional</li> </ul>	Yes (Conditional)  <b>Note:</b> This field is required when you are defining a two-dimensional pricing rule.
Print Zero	Used to indicate whether zero pricing should be displayed in the bill. The valid values are: <ul style="list-style-type: none"> <li>Yes</li> <li>No</li> </ul> <b>Note:</b> By default, <b>Yes</b> is selected.	Yes
Pricing Frequency	Used to indicate pricing frequency for the price item.  <b>Note:</b> This field appears only when <b>Price Item</b> is defined as <b>Only Pricing</b> and <b>Price Item Type</b> is defined as <b>Fees</b> .	Yes

- Enter the required details in the **Main** section.
- Define TFM Information in a price item pricing, if required.
- Define characteristics for a price item pricing, if required.
- Define parameters for a price item pricing, if required.
- Click **Save**.

The pricing is defined for the price item.

**Note:** A bundle cannot be assigned if its child price items are already assigned to a person and vice versa, in the same date range.

### Related Topics

For more information on...	See...
<b>Pricing (Person)</b> screen	<a href="#">Pricing (Person)</a> on page 473
<b>Search Price Item or Price Item Pricing</b> zone	<a href="#">Search Price Item</a> on page 479
How to search for an person	<a href="#">Searching for a Person</a> on page 185
How to define characteristics for a price item pricing.	<a href="#">Defining Characteristics for a Price Item Pricing</a> on page 405

For more information on...	See...
How to define parameters for a price item pricing.	<a href="#">Defining Parameters for a Price Item Pricing</a> on page 406
How to define TFM Information in a price item pricing.	<a href="#">Defining TFM Information in a Price Item Pricing</a> on page 407

## Defining Characteristics for a Price Item Pricing

### Prerequisites

To define characteristics for a price item pricing, you should have:

- Characteristic types defined in the application (where the characteristic entity is set to **Price Item**)

### Procedure

To define characteristics for a price item pricing that is assigned to an account:

1. Ensure that the **Characteristics** section is expanded when you are defining a price item pricing.

The **Characteristics** section contains the following columns:

Column Name	Column Description	Mandatory (Yes or No)
Effective Date	Used to specify the date from when the characteristic is effective for the price item pricing.	Yes (Conditional) <b>Note:</b> This field is required when you are defining a characteristic for the price item pricing.
Characteristic Type	Used to indicate the characteristic type. <b>Note:</b> The list includes only those characteristic types where the characteristic entity is set to <b>Price Item Pricing</b> .	Yes (Conditional) <b>Note:</b> This field is required when you are defining a characteristic for the price item pricing.
Characteristic Value	Used to specify the value for the characteristic type. <b>Note:</b> If you select a predefined characteristic type, the <b>Search</b> (🔍) icon appears corresponding to the <b>Characteristic Value</b> field. On clicking the <b>Search</b> icon, the <b>Predefined Characteristic Search</b> window appears. On specifying the value for a predefined characteristic type, the description of the characteristic value appears corresponding to the <b>Characteristic Value</b> field.	Yes (Conditional) <b>Note:</b> This field is required when you are defining a characteristic for the price item pricing.

2. Enter the required details in the **Characteristics** section.
3. If you want to define more than one characteristic for the price item pricing, click the **Add** (+) icon and then repeat step 3.



**Note:** However, if you want to remove a characteristic from the price item pricing, click the **Delete** (🗑️) icon corresponding to the characteristic.

4. Click **Save**.

The characteristics are defined for the price item pricing.

### **Related Topics**

<b>For more information on...</b>	<b>See...</b>
How to define a price item pricing	<a href="#">Defining a Price Item Pricing</a> on page 516
How to edit a price item pricing	<a href="#">Editing a Price Item Pricing</a> on page 560
How to override a price item pricing	<a href="#">Overriding a Price Item Pricing</a> on page 569

## **Defining Parameters for a Price Item Pricing**

### **Prerequisites**

To define parameters for a price item pricing, you should have:

- Parameters associated with the price item, in case, you want to define price item pricing based on multiple parameters

### **Procedure**

To define parameter details segment for a price item pricing that is assigned to an account:

1. Ensure that the **Price Item and Parameter Information** section is expanded when you are defining a price item pricing.

The **Price Item and Parameter Information** section contains the following field:

<b>Field Name</b>	<b>Field Description</b>
Price Item	Indicates the price item or price item bundle whose pricing details are listed in this section.

In addition, this section contains a grid which has the following columns:

<b>Column Name</b>	<b>Column Description</b>	<b>Mandatory (Yes or No)</b>
Parameter	Used to indicate the parameter that you want to associate with the price item pricing.  <b>Note:</b> The <b>Search</b> (🔍) icon appears corresponding to this field. On clicking the <b>Search</b> icon, the <b>Price Item Parameter Search</b> window appears. The parameter search results displays only those parameters where the <b>Price Item</b> check box is selected	Yes
Parameter Information	Displays a comma-separated string which contains of the following: <ul style="list-style-type: none"> <li>Parameter Description</li> <li>Mandatory (Yes or No)</li> <li>Priority</li> </ul>	Not applicable

Column Name	Column Description	Mandatory (Yes or No)
Parameter Value	Used to specify the value of the parameter.	Yes

- Enter the required details in the **Price Item and Parameter Information** section.
- If you want to define more than one parameter information for the price item pricing, click the **Add (+)** icon and then repeat step 2.

**Note:** However, if you want to remove a parameter information from the price item pricing, click the **Delete** (🗑️) icon corresponding to the parameter.

- Click **Save**.

The parameters are defined for the price item pricing.

### Related Topics

For more information on...	See...
How to define a price item pricing	<a href="#">Defining a Price Item Pricing</a> on page 516
How to edit a price item pricing	<a href="#">Editing a Price Item Pricing</a> on page 560
How to override a price item pricing	<a href="#">Overriding a Price Item Pricing</a> on page 569

## Defining TFM Information in a Price Item Pricing

### Prerequisites

To define the TFM information in a price item pricing, you should have:

- Transactions mapped to the price item defined in the application
- Aggregation or Rating Criteria data to be defined for the price item pricing

### Procedure

To define the TFM information in a price item pricing:

- Ensure that the **TFM Information** section is expanded when you are defining a price item pricing.

The **TFM Information** section contains the following fields:

Field Name	Field Description	Mandatory (Yes or No)
Ignore Transaction	Used to indicate whether the transactions mapped to the price item is considered for billing. The valid values are: <ul style="list-style-type: none"> <li>Yes</li> <li>No</li> </ul>	Yes
Aggregate Transactions	Used to indicate whether the transactions mapped to the price item is aggregated for billing. The valid values are: <ul style="list-style-type: none"> <li>Yes</li> <li>No</li> </ul>	Yes

Field Name	Field Description	Mandatory (Yes or No)
Aggregation Schedule	Used to indicate the transaction aggregation cycle. The valid values are: <ul style="list-style-type: none"> <li>• Daily</li> <li>• Weekly</li> <li>• Monthly</li> <li>• Quaterly</li> <li>• Yearly</li> </ul>	Yes
Transaction Rating Criteria	Used to indicate how and when the transaction legs mapped to the price item are rated. The valid values are: <ul style="list-style-type: none"> <li>• Aggregate Transactions and Then Rate Aggregated SQs</li> <li>• Do Not Rate Transactions</li> <li>• Rate Transaction and Aggregate Calc Lines Across Transaction</li> </ul>	Yes

2. Enter the required details in the **TFM Information** section.

**Note:** **TFM Information** section appears when the value for **Show Default Values in Price Item Pricing** option type of **C1\_FM feature configuration** is set to **Y** and **Price Item Available For** is **Pricing and Billing**.

3. Click **Save**.

The transactions are defined for the price item pricing.

### **Related Topics**

For more information on...	See...
How to define a price item pricing for an account	<a href="#">Assigning a Price Item to an Account</a> on page 466
How to edit a price item pricing for an account	<a href="#">Editing a Price Item Pricing of an Account</a> on page 458
How to override a price item pricing for an account	<a href="#">Overriding a Price Item Pricing of an Account</a> on page 462
How to define a price item pricing for a person	<a href="#">Assigning a Price Item to a Person</a> on page 500
How to edit a price item pricing for a person	<a href="#">Editing a Price Item Pricing of a Person</a> on page 492
How to override a price item pricing for a person	<a href="#">Overriding a Price Item Pricing of a Person</a> on page 496
How to define a price item pricing for a price list	<a href="#">Assigning a Price Item to a Price List</a> on page 401
How to edit a price item pricing for a price list	<a href="#">Editing a Price Item Pricing of a Price List</a> on page 397

## **Price Item Pricing (Used for Viewing)**

Once the pricing is defined for a price item pricing which is assigned to a account, person, or price list, the **Price Item Pricing** screen allows you to:

- Edit the details of a price item pricing
- Delete a price item pricing

- Submit a price item pricing for processing
- View the details of price components of the rate component
- View the details of tiering criteria, pricing eligibility criteria of a price component
- Add price components of the rate components
- Add tiering components, pricing eligibility criteria of the price components
- Edit price components, tiering criteria, pricing eligibility criteria
- Delete price components, tiering criteria, pricing eligibility criteria

**Note:**

When the price assignment is in **Draft** status and when:

- Approval Workflow is off then status is changed from **Draft** to **Active**.
- Approval Workflow is on then status is changed from **Draft** to **Pending in Approval**.

## Price Item Pricing

The **Price Item Pricing** zone displays the details of the price item pricing. It contains the following sections:

- **Pricing Information** - Displays basic information about the pricing of the price item. It contains the following fields:

Field Name	Field Description
Start Date	Displays the date from when the pricing of the price item is effective.
End Date	Displays the date till when the pricing of the price item is effective.

Field Name	Field Description
Price Assignment Type	<p>Indicates the type of price assignment. The valid values are:</p> <ul style="list-style-type: none"> <li>• <b>Post Processing</b> – Indicates that the pricing is used to generate post processing bill segment. This type of price assignment can be done on usage accounts. The post processing bill segment is generated when you generate the bill for the usage account and not when you bill the usage account through an invoice account.</li> <li>• <b>Post Processing – Invoice Based</b> – Indicates that the pricing is used to generate post processing bill segment. This type of price assignment is done on an invoice account, and, as a result, the post processing bill segment is generated on the invoice account.</li> </ul> <div style="border: 1px solid black; padding: 5px; margin: 10px 0;"> <p><b>Note:</b> This is not applicable for price items which are defined for <b>Pricing</b> and where the <b>Price Item Type</b> field is set to <b>Fees</b>.</p> </div> <ul style="list-style-type: none"> <li>• <b>Post Processing – Price Item Based</b> – Indicates that the pricing is used to generate post processing bill segment. This type of price assignment is done on both invoice and usage accounts, but the post processing bill segment is generated only on the invoice account.</li> <li>• <b>Regular</b> – Indicates that the pricing is used to generate regular bill segment.</li> </ul> <div style="border: 1px solid black; padding: 5px; margin: 10px 0;"> <p><b>Note:</b> This is not applicable for price items which are defined for <b>Pricing</b> and where the <b>Price Item Type</b> field is set to <b>Fees</b>. By default, the <b>Regular</b> option is selected in the <b>Bundle Type</b> field for price item which are applicable for <b>Pricing</b> and cannot be edited. The post processing bill segment is generated when the <b>Post Processing Sequence (PPSEQ)</b> characteristic is defined for the price item and when the price item is associated with another price item using the <b>Price Item</b> relationship type.</p> </div>
Pricing Eligibility	Indicates whether the price item pricing is eligible for pricing assignment or not.
Pricing Status	<p>Indicates the pricing assignment status of the price item pricing. The valid values are:</p> <ul style="list-style-type: none"> <li>• Draft</li> <li>• Active</li> <li>• Inactive</li> <li>• Proposed</li> <li>• Rejected</li> <li>• Template</li> </ul>
Pricing Currency	<p>Indicates the currency in which the price item pricing is defined.</p> <div style="border: 1px solid black; padding: 5px; margin: 10px 0;"> <p><b>Note:</b> It has a link. On clicking the link, the <b>Currency</b> screen appears where you can view the details of the currency.</p> </div>
Rate Schedule	<p>Indicates the rate schedule that is used to define the price item pricing.</p> <div style="border: 1px solid black; padding: 5px; margin: 10px 0;"> <p><b>Note:</b> It has a link. On clicking the link, the <b>Rate Schedule</b> screen appears where you can view the details of the rate schedule.</p> </div>

Field Name	Field Description
Pricing Rule Type	Indicates the pricing rule type. The valid value is: <ul style="list-style-type: none"> <li>Two-Dimensional</li> </ul>
Print Zero	Indicates the zero pricing displayed in the bill. The valid values are: <ul style="list-style-type: none"> <li>Yes</li> <li>No</li> </ul>
Price Assignment Usage	Indicates whether the price item pricing is applicable to all customers or only to new customers. The valid values are: <ul style="list-style-type: none"> <li>All Customers</li> <li>New Customers</li> </ul>

- **TFM Information** – Displays the transactions mapped to the price item pricing. It contains the following fields:

Field Name	Field Description
Ignore Transaction	Indicates whether the transactions mapped to the price item pricing is considered for billing or not. The valid values are: <ul style="list-style-type: none"> <li>Yes</li> <li>No</li> </ul>
Aggregate Transactions	Indicates whether the transactions mapped to the price item pricing is aggregated for billing or not. The valid values are: <ul style="list-style-type: none"> <li>Yes</li> <li>No</li> </ul>
Aggregation Schedule	Indicates the transaction aggregation cycle. The valid values are: <ul style="list-style-type: none"> <li>Daily</li> <li>Weekly</li> <li>Monthly</li> <li>Quarterly</li> <li>Yearly</li> </ul>
Transaction Rating Criteria	Indicates how and when the transaction legs mapped to the price item are rated. The valid values are: <ul style="list-style-type: none"> <li>Aggregate Transactions and Then Rate Aggregated SQs</li> <li>Do Not Rate Transactions</li> </ul>

**Note:**

**TFM Information** section appears when the value for **Show Default Values in Price Item Pricing** option type of **C1\_FM feature configuration** is set to **Y** and **Price Item Usage** field is set to **Pricing and Billing**.

**TFM Information** section does not appear when the **Price Item Usage** field is set to **Only Pricing** and the **Price Item Type** field is set to **Fees**, then, only the **Pricing Frequency** field appears.

- **Characteristics** – Lists the characteristics defined for the price item pricing. It contains the following columns:

Column Name	Column Description
Effective Date	Displays the date from when the characteristic is effective for the price item pricing.
Characteristic Type	Indicates the characteristic type.
Characteristic Value	Displays the value of the characteristic type.

- **Price Item and Parameter Information** – Displays the parameter details for the price item pricing. It contains the following field:

Field Name	Field Description
Price Item	Indicates the price item or price item bundle whose pricing details are listed in this section.

In addition, this section contains the following columns:

Column Name	Column Description
Parameter	Indicates the parameter that is associated with the price item pricing.
Parameter Value	Displays the parameter value.

- **Record Actions** – This section contains the following buttons:

Column Name	Column Description
Edit	Used to edit the details of the price item pricing.  <b>Note:</b> The <b>Edit</b> button appears only when the price item pricing is in the <b>Draft</b> status.
Delete	Used to delete the price item pricing.  <b>Note:</b> The <b>Delete</b> button appears only when the price item pricing is in the <b>Draft</b> status.
Submit	Used to submit the price item pricing for validation and processing.  <b>Note:</b> The <b>Submit</b> button appears only when the price item pricing is in the <b>Draft</b> status.

- **Record Information** – This section contains the following field:

Field Name	Field Description
Business Object	Indicates the business object using which the price item pricing is created. In addition, a context menu appears corresponding to this field which helps in navigating to other screens in the application.  <b>Note:</b> It has a link. On clicking the link, the <b>Business Object</b> screen appears where you can view the details of the respective business object.

## Rate and Price Component Summary

The **Rate and Price Component Summary** zone lists the following in a tree view:

- Information string of price component with tiers where the rate schedule is flat.

- Information string of price component with tiers where the rate schedule is step.
- Information string of price component with tiers where the rate schedule is threshold.

## Rate Components

The **Rate Components** zone lists rate components and its details for price item pricing that are assigned to an account, person, or price list. This zone contains the following columns:

Column Name	Column Description
Sequence	Indicates the sequence number of the rate component.
Rate Components	Displays a comma-separated string which consists of the following: <ul style="list-style-type: none"> <li>• Rate Component ID</li> <li>• Rate Component Sequence Number</li> <li>• Tiering Setup of the Rate Component</li> </ul>
Add Price Component	On clicking the <b>Add Price Component</b> button, the <b>Price Component</b> screen appears where you can add the price component for the rate component. <div style="border: 1px solid black; padding: 5px; margin-top: 10px;"> <p><b>Note:</b> This button appears only when the <b>Pricing Status</b> of the price item pricing is in <b>Draft, Proposed</b> and <b>Template</b> status.</p> </div>

On clicking the broadcast **Broadcast** (📡) icon corresponding to the rate component, the **Price Components** zone appears with the details of the price components for the respective rate component.

You can change the layout of this zone. For more information on how to change the layout, see [Changing the Layout](#) on page 2882.

### Related Topics

For more information on...	See...
How to view a Price Item Pricing	<a href="#">Price Item Pricing (Used for Viewing)</a> on page 507
<b>Price Components</b> zone	<a href="#">Price Components</a> on page 512
How to define a price component for a rate component	<a href="#">Defining a Price Component for a Rate Component</a> on page 524
How to view price components of a rate component	<a href="#">Viewing the Price Components of a Rate Component</a> on page 519

## Price Components

The **Price Components** zone lists details of price components of the rate component for price item pricing that are assigned to an account, person, or price list. This zone contains the following columns:

Column Name	Column Description
Sequence	Indicates the sequence number of the price component.
Show Price Component	Indicates whether to display the price components or not. The valid values are: <ul style="list-style-type: none"> <li>• Yes</li> <li>• No</li> </ul>



Column Name	Column Description
Description	Displays a comma-separated string which consists of the following: <ul style="list-style-type: none"> <li>• Tiering Setup of the Price Component</li> <li>• Description of the Price Component</li> </ul>
Rate Value	Indicates the rate defined for the price component.
Edit	On clicking the <b>Edit</b> (✎) icon, the <b>Price Component</b> screen appears where you can edit the details of the price component.
Delete	On clicking the <b>Delete</b> (🗑) icon, you can delete the price component. <div style="border: 1px solid black; padding: 5px; margin-top: 10px;"> <p><b>Note:</b> The <b>Delete</b> icon appears only when the price assignment is in <b>Draft, Proposed</b> or <b>Template</b> status.</p> </div>

By default, the **Price Components** zone does not appear in the **Price Item Pricing** screen. It appears only when you click the broadcast **Broadcast** (📡) icon corresponding to a rate component in the **Rate Components** zone.

On clicking the **Broadcast** (📡) icon corresponding to a price component, the **Tiering Criteria** and **Pricing Eligibility Criteria** zones appear with details of the respective tiering, pricing eligibility criteria.

**Note:**

The **Tiering Criteria** zone appears only when **Tiering Type** for the rate component is **STEP** or **Threshold**.

The **Pricing Eligibility Criteria** zone appears only when eligibility checkbox is selected in the **Price Item Pricing** screen and details for pricing eligibility criteria is added in the **Price Component** screen.

You can define price component for a rate component by clicking the **Add** link in the upper right corner of this zone.

You can change the layout of this zone. For more information on how to change the layout, see [Changing the Layout](#) on page 2882.

**Related Topics**

For more information on...	See...
How to view a Price Item Pricing	<a href="#">Price Item Pricing (Used for Viewing)</a> on page 507
<b>Rate Components</b> zone	<a href="#">Rate Components</a> on page 512
<b>Tiering Criteria</b> zone	<a href="#">Tiering Criteria</a> on page 514
<b>Pricing Eligibility Criteria</b> zone	<a href="#">Pricing Eligibility Criteria</a> on page 514
How to define a price component for a rate component	<a href="#">Defining a Price Component for a Rate Component</a> on page 524
How to define a tiering criteria for a price component	<a href="#">Defining a Tiering Criteria for a Price Component</a> on page 527
How to view the tiering criteria of a price component	<a href="#">Viewing the Tiering Criteria of a Price Component</a> on page 520
How to define a pricing eligibility criteria for a price component	<a href="#">Defining a Pricing Eligibility Criteria for a Price Component</a> on page 530
How to view the pricing eligibility criteria of a price component	<a href="#">Viewing the Pricing Eligibility Criteria of a Price Component</a> on page 522

## Tiering Criteria

The **Tiering Criteria** zone lists the detail of tiering criterions that are used in the tiering range. This zone contains the following columns:

Column Name	Column Description
Sequence	Indicates the sequence number of the tiering criteria.
Tiering Criterion	Indicates the tiering criterion.
Price Item	Displays the price item.
Parameter Information	Displays information about the parameter associated with the price item.
Lower Limit	Displays the lower limit of the tiering range.
Upper Limit	Displays the upper limit of the tiering range.
Edit	On clicking the <b>Edit</b> (✎) icon, the <b>Price Component</b> screen appears where you can edit the details of the tiering criteria.
Delete	On clicking the <b>Delete</b> (🗑) icon, you can delete the tiering criteria.  <b>Note:</b> The <b>Delete</b> icon appears only when the price assignment is in <b>Draft</b> , <b>Proposed</b> or <b>Template</b> status.

By default, the **Tiering Criteria** zone does not appear in the **Price Item Pricing** screen. It appears only when you click the broadcast **Broadcast** (📡) icon corresponding to a price component in the **Price Components** zone.

**Note:**

The **Tiering Criteria** zone appears only when **Tiering Type** for the rate component is **STEP** or **Threshold**.

You can define tiering criteria for a price component by clicking the **Add** link in the upper right corner of this zone.

You can change the layout of this zone. For more information on how to change the layout, see [Changing the Layout](#) on page 2882.

### Related Topics

For more information on...	See...
How to view a Price Item Pricing	<a href="#">Price Item Pricing (Used for Viewing)</a> on page 507
<b>Price Components</b> zone	<a href="#">Price Components</a> on page 512
How to define a price component for a rate component	<a href="#">Defining a Price Component for a Rate Component</a> on page 524
How to define a tiering criteria for a price component	<a href="#">Defining a Tiering Criteria for a Price Component</a> on page 527
How to view the tiering criteria of a price component	<a href="#">Viewing the Tiering Criteria of a Price Component</a> on page 520

## Pricing Eligibility Criteria

The **Pricing Eligibility Criteria** zone lists the detail of parameters used while defining the pricing eligibility criteria. This zone contains the following columns:

Column Name	Column Description
Sequence	Indicates the sequence number of the tiering criteria.
Parameter	Indicates the parameter (on the left hand side) is used in the pricing eligibility criteria.
Operator	Displays the relational operator defined for the relation between the parameter name and value.
Parameter Value Type	Indicates whether the parameter (on the left hand side) is compared against another parameter (on the right hand side) or directly against a parameter value.
Parameter	Indicates the parameter (on the right hand side) against which you have compared the parameter (on the left hand side).
Parameter Value	Indicates the parameter value against which you have compared the parameter (on the left hand side).
Is True	Indicates what happens when the condition is true (satisfied). The valid values are: <ul style="list-style-type: none"> <li>• <b>Check Next Condition</b> – Indicates that the condition with consecutive sequence number is executed.</li> <li>• <b>Rule Is False</b> – Indicates that the action specified in the <b>Rule False Action</b> field is executed.</li> <li>• <b>Rule Is True</b> – Indicates that the action specified in the <b>Rule True Action</b> field is executed.</li> </ul>
Is False	Indicates what happens when the condition is false (not satisfied). The valid values are: <ul style="list-style-type: none"> <li>• <b>Check Next Condition</b> – Indicates that the condition with consecutive sequence number is executed.</li> <li>• <b>Rule Is False</b> – Indicates that the action specified in the <b>Rule False Action</b> field is executed</li> <li>• <b>Rule Is True</b> – Indicates that the action specified in the <b>Rule True Action</b> field is executed.</li> </ul>
Is Insufficient	Indicates what happens when the data is insufficient. The valid values are: <ul style="list-style-type: none"> <li>• <b>Check Next Condition</b> – Indicates that the condition with consecutive sequence number is executed.</li> <li>• <b>Rule Is False</b> – Indicates that the action specified in the <b>Rule False Action</b> field is executed</li> <li>• <b>Rule Is True</b> – Indicates that the action specified in the <b>Rule True Action</b> field is executed.</li> </ul>
Edit	On clicking the <b>Edit</b> (✎) icon, the <b>Price Component</b> screen appears where you can edit the details of the pricing eligibility criteria.
Delete	On clicking the <b>Delete</b> (🗑) icon, you can delete the pricing eligibility criteria. <div style="border: 1px solid black; padding: 5px; margin-top: 10px;"> <p><b>Note:</b> The <b>Delete</b> icon appears only when the price assignment is in <b>Draft, Proposed</b> or <b>Template</b> status.</p> </div>

By default, the **Pricing Eligibility Criteria** zone does not appear in the **Price Item Pricing** screen. It appears only when you click the broadcast **Broadcast** (📡) icon corresponding to a price component in the **Price Components** zone.

**Note:**

The **Pricing Eligibility Criteria** zone appears only when eligibility checkbox is selected in the **Price Item Pricing** screen and details for pricing eligibility criteria is added in the **Price Component** screen.

You can define pricing eligibility criteria for a price component by clicking the **Add** link in the upper right corner of this zone.

You can change the layout of this zone. For more information on how to change the layout, see [Changing the Layout](#) on page 2882.

**Related Topics**

For more information on...	See...
How to view a Price Item Pricing	<a href="#">Price Item Pricing (Used for Viewing)</a> on page 507
<b>Price Components</b> zone	<a href="#">Price Components</a> on page 512
How to define a price component for a rate component	<a href="#">Defining a Price Component for a Rate Component</a> on page 524
How to define a pricing eligibility criteria for a price component	<a href="#">Defining a Pricing Eligibility Criteria for a Price Component</a> on page 530
How to view the pricing eligibility criteria of a price component	<a href="#">Viewing the Pricing Eligibility Criteria of a Price Component</a> on page 522

**Two-Dimensional Pricing**

The **Two-Dimensional Pricing** zone displays the details of the two-dimensional pricing. It contains the following field:

Field Name	Field Description
Pricing Information	Displays the concatenated string consisting of pricing information and pricing ID which are separated by a comma(,) for an account, person or price list.

In addition, this section contains the following fields in a grid:

Field Name	Field Description
Step Criterion	Displays the <b>Price Criteria</b> of the price component
Threshold Parameter	Displays the parameter of the price component eligibility
Tiering Range	Displays the tiering range of the pricing.

**Defining a Price Item Pricing****Prerequisites**

To define pricing for a price item, you should have:



- Transactions mapped to the price item defined in the application
- Rate schedules, rate versions, and rate components defined in the application
- Tiering criteria defined in the application
- Tiering setup for the rate components defined in the application
- Pricing eligibility defined in the application

- Parameters associated with the price item (in case you want to define price item pricing based on multiple parameters)

### **Procedure**

To define pricing for a price item:

- Do either of the following:

<b>If you want to...</b>	<b>Then...</b>
Define pricing for a price item that you want assign to a customer	<ol style="list-style-type: none"> <li>Access the <b>Pricing (Person)</b> screen.</li> <li>Search for the price item that you want to assign to the customer.</li> <li>In the <b>Search Results</b> section, click the <b>Assign</b>  icon in the <b>Assign</b> column corresponding to the price item that you want to assign to the customer.</li> </ol>
Define pricing for a price item that you want assign to an account	<ol style="list-style-type: none"> <li>Access the <b>Pricing (Account)</b> screen.</li> <li>Search for the price item that you want to assign to the account.</li> <li>In the <b>Search Results</b> section, click the <b>Assign</b>  icon in the <b>Assign</b> column corresponding to the price item that you want to assign to the account.</li> </ol>
Define pricing for a price item that you want assign to a price list	<ol style="list-style-type: none"> <li>Access the <b>Price list Price Item Pricing</b> screen.</li> <li>Search for the price item that you want to assign to the price list.</li> <li>In the <b>Search Results</b> section, click the link in the <b>Price Item</b> column corresponding to the price item that you want to assign to the price list.</li> </ol>

The **Price Item Pricing** screen appears.

- Enter the transaction feed management information that you want to map to the price item pricing.
- Enter the date from when the price item pricing is effective in the **Effective Start Date** field.
- Select the currency, in which you want to define the pricing, from the **Pricing Currency** list.
- Enter the rate schedule that you want to use while defining price item pricing.
  - Parameter details segment is displayed in the **Price Item and Parameter Information** section.

**Note:** You can specify multiple parameter codes associated with the price items, search for a price item parameters using the **Search**  icon corresponding to the **Parameter** field.

- A section appears at the bottom of the screen.

**Note:** You can search for a rate schedule by clicking the **Search** (🔍) icon corresponding to the field.

6. Select the type of price assignment from the respective field.
7. Select **All Customers** or **New Customers** from the **Apply To** list depending on whether you want to apply the price item pricing to all customers or only to the new customers.
8. Select **Pricing Frequency** and **Advance Pricing** (this field would be displayed only if additionally **Price Assignment Type** is **Post Processing**). These fields are applicable for price item value as **Pricing Only** and **Price Item Type** value as **Fees**.
9. The section at the bottom of the screen contains rate components of the rate schedule on the left hand side and the eligibility and tiering ranges per price component on the right hand side.
10. Rate is used to specify the price for the price item.
11. You can expand details to add tiering criteria and pricing eligibility criteria by clicking the **Add** (📄+) icon corresponding to the **Eligibility tier Details** field.
12. If price component is for **Flat Rate** then **Pricing Eligibility Criteria** details are displayed and if price component is for **Step Tiering** or **Threshold Tiering** then **Pricing Eligibility Criteria** and **Tiering Criteria** details are displayed.
13. In the **Pricing Eligibility Criteria** section, you can enter price component details to following mandatory fields:
  - a) You can specify relational **Operator** to define relation between **LHS Parameter Code** and **RHS Parameter Code**.
  - b) You can select the type of pricing eligibility for **RHS Parameter Value Type**.
  - c) Select the values from **Is True**, **Is False** and **Is Insufficient** that indicates what should happen when the condition is true, false or insufficient.
14. To add more than one **Pricing Eligibility Criteria**, click the **Add** (+) icon and to delete the pricing eligibility click the **Delete** (🗑️) icon corresponding to the **Sequence Number**.
15. In the **Tiering Criteria** section, you can enter price component details to the following mandatory fields:
  - a) Select the **Tiering Criterion** from the list.
  - b) If you want to define tiering range based on some other price item or bundle's usage, enter the price item or bundle code in the **Price Item** field

**Note:** You can search for a price item by clicking the **Search** (🔍) icon corresponding to the **Price item** field.

- c) You can define the price item pricing based on multiple parameters, select the parameters using the **Search** (🔍) icon corresponding to the **Price Item Parameters** field.
  - d) To add more than one **Price Item Parameters**, click the **Add** (+) icon and to delete the price item parameters click the **Delete** (🗑️) icon corresponding to the **Parameter** field.
  - e) Enter the lower and upper limits of the tiering range in the **From** and **To** fields.
16. To add more than one **Price Component Details**, click the **Add** (+) icon and repeat the steps from 9 to 14. To delete the details of price component click the **Delete** (🗑️) icon corresponding to the **Price Component Sequence** field.
  17. Define characteristics for the price assignment, if required.
  18. Click **Save**.  
The pricing is defined for the price item.

**Note:** A bundle cannot be assigned if its child price items are already assigned to a price list, customer, or an account, and vice versa, in the same date range.

### Related Topics

For more information on...	See...
Price Item Pricing screen	<a href="#">Price Item Pricing</a>
How to define characteristics for the price assignment	<a href="#">Price Assignment Characteristics</a>

## Viewing the Price Components of a Rate Component

### Procedure

To view the details of price components of a rate component:

1. Do either of the following:

If you want to view...	Then...
Price components of Price Item Pricing assigned to an account	<ol style="list-style-type: none"> <li>1. Search for the account in the <b>Customer 360° View</b> screen.</li> <li>2. In the <b>Search Results</b> section, click the <b>Show Context Menu</b> (☰) icon corresponding to the account whose <i>details</i> you want to view. A menu appears.</li> <li>3. Click the <b>Go To Effective Pricing</b> menu option. The <b>Pricing (Account)</b> screen appears.</li> <li>4. Price assignments effective for the account appears in the <b>Effective Price Assignments for Account</b> zone.</li> <li>5. In the <b>Search Results</b> section, click the link in the <b>Pricing Information</b> column corresponding to the price item whose pricing details you want to view.</li> </ol>
Price components of Price Item Pricing assigned to a person	<ol style="list-style-type: none"> <li>1. Search for the person in the <b>Customer 360° View</b> screen.</li> <li>2. In the <b>Search Results</b> section, click the <b>Show Context Menu</b> (☰) icon corresponding to the person whose <i>details</i> you want to view. A menu appears.</li> <li>3. Click the <b>Go To Effective Pricing</b> menu option. The <b>Pricing (Person)</b> screen appears.</li> <li>4. Price assignments effective for the person appears in the <b>Effective Price Assignments for Person</b> zone.</li> <li>5. In the <b>Search Results</b> section, click the link in the <b>Pricing Information</b> column corresponding to the price item whose pricing details you want to view.</li> </ol>

If you want to view...	Then...
Price components of Price Item Pricing assigned to a price list	<ol style="list-style-type: none"> <li>1. Search for the price list in the <b>Price List</b> screen.</li> <li>2. In the <b>Search Results</b> section, click the <b>Price List Pricing</b> () icon corresponding to the price list whose <i>details</i> you want to view. The <b>Price List Price Item Pricing</b> screen appears.</li> <li>3. Price items assigned to the price list appears in the <b>Price List Price Items</b> zone.</li> <li>4. In the <b>Search Results</b> section, click the link in the <b>Pricing Information</b> column corresponding to the price item whose pricing details you want to view.</li> </ol>

2. The **Price Item Pricing** screen appears.
3. In the **Rate Components** zone, click the **Broadcast** () icon corresponding to a rate component in the **Rate Components** zone.  
The **Price Components** zone appears.
4. View the details of the price components of the rate component in the **Price Components** zone.

#### Related Topics

For more information on...	See...
How to search for an account	<a href="#">Searching for an Account</a>
How to search for a person	<a href="#">Searching for a Person</a>
How to search for a price list	<a href="#">Searching for a Price List</a> on page 371
Price Item Pricing screen	<a href="#">Price Item Pricing (Used for Viewing)</a> on page 507
Rate Components zone	<a href="#">Rate Components</a> on page 512
Price Components zone	<a href="#">Price Components</a> on page 512

## Viewing the Tiering Criteria of a Price Component

### Procedure

To view the details of tiering criteria of a price component:

1. Do either of the following:

If you want to view...	Then...
Tiering criteria of Price Item Pricing assigned to an account	<ol style="list-style-type: none"> <li>1. Search for the account in the <b>Customer 360° View</b> screen.</li> <li>2. In the <b>Search Results</b> section, click the <b>Show Context Menu</b> () icon corresponding to the account whose <i>details</i> you want to view. A menu appears.</li> <li>3. Click the <b>Go To Effective Pricing</b> menu option.</li> </ol>



If you want to view...	Then...
	<p>The <b>Pricing (Account)</b> screen appears.</p> <ol style="list-style-type: none"> <li>Price assignments effective for the account appears in the <b>Effective Price Assignments for Account</b> zone.</li> <li>In the <b>Search Results</b> section, click the link in the <b>Pricing Information</b> column corresponding to the price item whose pricing details you want to view.</li> </ol>
Tiering criteria of Price Item Pricing assigned to a person	<ol style="list-style-type: none"> <li>Search for the person in the <b>Customer 360° View</b> screen.</li> <li>In the <b>Search Results</b> section, click the <b>Show Context Menu</b> (☰) icon corresponding to the person whose details you want to view. A menu appears.</li> <li>Click the <b>Go To Effective Pricing</b> menu option. The <b>Pricing (Person)</b> screen appears.</li> <li>Price assignments effective for the person appears in the <b>Effective Price Assignments for Person</b> zone.</li> <li>In the <b>Search Results</b> section, click the link in the <b>Pricing Information</b> column corresponding to the price item whose pricing details you want to view.</li> </ol>
Tiering criteria of Price Item Pricing assigned to a price list	<ol style="list-style-type: none"> <li>Search for the price list in the <b>Price List</b> screen.</li> <li>In the <b>Search Results</b> section, click the <b>Price List Pricing</b> (☰) icon corresponding to the price list whose details you want to view. The <b>Price List Price Item Pricing</b> screen appears.</li> <li>Price items assigned to the price list appears in the <b>Price List Price Items</b> zone.</li> <li>In the <b>Search Results</b> section, click the link in the <b>Pricing Information</b> column corresponding to the price item whose pricing details you want to view.</li> </ol>

- The **Price Item Pricing** screen appears.
- In the **Rate Components** zone, click the **Broadcast** (📡) icon corresponding to a rate component in the **Rate Components** zone.  
The **Price Components** zone appears.
- In the **Price Components** zone, click the **Broadcast** (📡) icon corresponding to a price component in the **Price Components** zone.  
The **Tiering Criteria** zone appears.
- View the details of tiering criterions that are used in the tiering range in **Tiering Criteria** zone.

**Note:**

The **Tiering Criteria** zone appears only when **Tiering Type** for the rate component is **STEP** or **Threshold**.

**Related Topics**

For more information on...	See...
How to search for an account	<a href="#">Searching for an Account</a>
How to search for a person	<a href="#">Searching for a Person</a>
How to search for a price list	<a href="#">Searching for a Price List</a> on page 371
<b>Price Item Pricing</b> screen	<a href="#">Price Item Pricing (Used for Viewing)</a> on page 507
<b>Rate Components</b> zone	<a href="#">Rate Components</a> on page 512
<b>Price Components</b> zone	<a href="#">Price Components</a> on page 512
<b>Tiering Criteria</b> zone	<a href="#">Tiering Criteria</a> on page 514



**Viewing the Pricing Eligibility Criteria of a Price Component****Procedure**

To view the details of pricing eligibility criteria of a price component:

1. Do either of the following:

If you want to view...	Then...
Pricing eligibility criteria of Price Item Pricing assigned to an account	<ol style="list-style-type: none"> <li>1. Search for the account in the <b>Customer 360° View</b> screen.</li> <li>2. In the <b>Search Results</b> section, click the <b>Show Context Menu</b> (☰) icon corresponding to the account whose <i>details</i> you want to view. A menu appears.</li> <li>3. Click the <b>Go To Effective Pricing</b> menu option. The <b>Pricing (Account)</b> screen appears.</li> <li>4. Price assignments effective for the account appears in the <b>Effective Price Assignments for Account</b> zone.</li> <li>5. In the <b>Search Results</b> section, click the link in the <b>Pricing Information</b> column corresponding to the price item whose pricing details you want to view.</li> </ol>
Pricing eligibility criteria of Price Item Pricing assigned to a person	<ol style="list-style-type: none"> <li>1. Search for the person in the <b>Customer 360° View</b> screen.</li> <li>2. In the <b>Search Results</b> section, click the <b>Show Context Menu</b> (☰) icon corresponding to the person whose <i>details</i> you want to view. A menu appears.</li> <li>3. Click the <b>Go To Effective Pricing</b> menu option.</li> </ol>

If you want to view...	Then...
	<p>The <b>Pricing (Person)</b> screen appears.</p> <ol style="list-style-type: none"> <li>Price assignments effective for the person appears in the <b>Effective Price Assignments for Person</b> zone.</li> <li>In the <b>Search Results</b> section, click the link in the <b>Pricing Information</b> column corresponding to the price item whose pricing details you want to view.</li> </ol>
Pricing eligibility criteria of Price Item Pricing assigned to a price list	<ol style="list-style-type: none"> <li>Search for the price list in the <b>Price List</b> screen.</li> <li>In the <b>Search Results</b> section, click the <b>Price List Pricing</b> () icon corresponding to the price list whose details you want to view. The <b>Price List Price Item Pricing</b> screen appears.</li> <li>Price items assigned to the price list appears in the <b>Price List Price Items</b> zone.</li> <li>In the <b>Search Results</b> section, click the link in the <b>Pricing Information</b> column corresponding to the price item whose pricing details you want to view.</li> </ol>

- The **Price Item Pricing** screen appears.
- In the **Rate Components** zone, click the **Broadcast** () icon corresponding to a rate component in the **Rate Components** zone.  
The **Price Components** zone appears.
- In the **Price Components** zone, click the **Broadcast** () icon corresponding to a price component in the **Price Components** zone.  
The **Pricing Eligibility Criteria** zone appears.
- View the details of parameters used while defining the pricing eligibility criteria in **Pricing Eligibility Criteria** zone.

**Note:**

The **Pricing Eligibility Criteria** zone appears only when eligibility checkbox is selected in the **Price Item Pricing** screen and details for pricing eligibility criteria is added in the **Price Component** screen.

**Related Topics**

For more information on...	See...
How to search for an account	<a href="#">Searching for an Account</a>
How to search for a person	<a href="#">Searching for a Person</a>
How to search for a price list	<a href="#">Searching for a Price List</a> on page 371
<b>Price Item Pricing</b> screen	<a href="#">Price Item (Used for Viewing)</a> on page 339
<b>Rate Components</b> zone	<a href="#">Rate Components</a> on page 512

For more information on...	See...
Price Components zone	<a href="#">Price Components</a> on page 512
Tiering Criteria zone	<a href="#">Tiering Criteria</a> on page 514
Pricing Eligibility Criteria zone	<a href="#">Pricing Eligibility Criteria</a> on page 514

## Defining a Price Component for a Rate Component

### Prerequisites

To define a price component for a rate component, you should have:



- Rate component defined for the price item in the application

### Procedure

To define price component for a rate component:

1. Do either of the following:

If you want to define...	Then...
Price components of Price Item Pricing assigned to an account	<ol style="list-style-type: none"> <li>1. Search for the account in the <b>Customer 360° View</b> screen.</li> <li>2. In the <b>Search Results</b> section, click the <b>Show Context Menu</b> (☰) icon corresponding to the account whose details you want to view. A menu appears.</li> <li>3. Click the <b>Go To Effective Pricing</b> menu option. The <b>Pricing (Account)</b> screen appears.</li> <li>4. Price assignments effective for the account appears in the <b>Effective Price Assignments for Account</b> zone.</li> <li>5. In the <b>Search Results</b> section, click the link in the <b>Pricing Information</b> column corresponding to the price item whose pricing details you want to view. The <b>Price Item Pricing</b> screen appears.</li> </ol> <div style="border: 1px solid black; padding: 5px; margin-top: 10px;"> <p><b>Tip:</b> Alternatively, you can access the <b>Price Item Pricing</b> screen by:</p> <ol style="list-style-type: none"> <li>1. Search for a price item in the <b>Search Price Item or Price Item Pricing</b> zone.</li> <li>2. In the <b>Search Results</b> section, click the <b>Assign</b> (📄) icon corresponding to the price item.</li> <li>3. Enter the required details in the <b>Price Item Pricing</b> screen and click <b>Save</b>.</li> <li>4. The <b>Price Item Pricing</b> screen appears.</li> </ol> </div>
Price components of Price Item Pricing assigned to a person	<ol style="list-style-type: none"> <li>1. Search for the person in the <b>Customer 360° View</b> screen.</li> </ol>

If you want to define...	Then...
	<ol style="list-style-type: none"> <li>2. In the <b>Search Results</b> section, click the <b>Show Context Menu</b> () icon corresponding to the person whose <i>details</i> you want to view. A menu appears.</li> <li>3. Click the <b>Go To Effective Pricing</b> menu option. The <b>Pricing (Person)</b> screen appears.</li> <li>4. Price assignments effective for the person appears in the <b>Effective Price Assignments for Person</b> zone.</li> <li>5. In the <b>Search Results</b> section, click the link in the <b>Pricing Information</b> column corresponding to the price item whose pricing details you want to view. The <b>Price Item Pricing</b> screen appears.</li> </ol> <div style="border: 1px solid black; padding: 5px; margin-top: 10px;"> <p><b>Tip:</b> Alternatively, you can access the <b>Price Item Pricing</b> screen by:</p> <ol style="list-style-type: none"> <li>1. Search for a price item in the <b>Search Price Item or Price Item Pricing</b> zone.</li> <li>2. In the <b>Search Results</b> section, click the <b>Assign</b> () icon corresponding to the price item.</li> <li>3. Enter the required details in the <b>Price Item Pricing</b> screen and click <b>Save</b>.</li> <li>4. The <b>Price Item Pricing</b> screen appears.</li> </ol> </div>
Price components of Price Item Pricing assigned to a price list	<ol style="list-style-type: none"> <li>1. Search for the price list in the <b>Price List</b> screen.</li> <li>2. In the <b>Search Results</b> section, click the <b>Price List Pricing</b> () icon corresponding to the price list whose <i>details</i> you want to view. The <b>Price List Price Item Pricing</b> screen appears.</li> <li>3. Price items assigned to the price list appears in the <b>Price List Price Items</b> zone.</li> <li>4. In the <b>Search Results</b> section, click the link in the <b>Pricing Information</b> column corresponding to the price item whose pricing details you want to view. The <b>Price Item Pricing</b> screen appears.</li> </ol>

If you want to define...	Then...
	<p><b>Tip:</b> Alternatively, you can access the <b>Price Item Pricing</b> screen by:</p> <ol style="list-style-type: none"> <li>1. Search for a price item in the <b>Search Price Item or Price Item Pricing</b> zone.</li> <li>2. In the <b>Search Results</b> section, click the <b>Assign</b> () icon corresponding to the price item.</li> <li>3. Enter the required details in the <b>Price Item Pricing</b> screen and click <b>Save</b>.</li> <li>4. The <b>Price Item Pricing</b> screen appears.</li> </ol>

2. Click the **Add Price Component** button in the **Add Price Component** of **Rate Components** zone.

The **Price Component** screen appears. It contains the following fields:

Field Name	Field Description
Pricing Information	Displays the concatenated string consisting of pricing information and pricing ID which are separated by a colon (:) for an account, person or price list.
Rate Component Information	Displays a comma-separated string which consists of the following: <ul style="list-style-type: none"> <li>• Rate Component Sequence</li> <li>• Tiering Type of the Rate Component</li> </ul>

In addition, this screen contains the following sections:

- **Main** – Used to specify the basic details about the price component.
- **Tiering Criteria** – Used to specify the details of tiering criterions that are used in the tiering range.
- **Pricing Eligibility Criteria** – Used to specify the details of parameters used while defining the pricing eligibility criteria.

The **Main** section contains the following fields:

Field Name	Field Description	Mandatory (Yes or No)
Sequence	Used to indicate the sequence in which price component should be considered.	Yes
Show Price Component	Used to indicate whether the price component should appear or not.	Yes
Description	Used to specify the description of the price component.	Yes
Rate Value	Used to indicate the rate defined for the price component.	Yes

**Tip:** Alternatively, you can access the **Price Component** screen by clicking the **Add** link to the right hand side corner of the **Price Components** zone.

3. Enter the required details in the **Main** section.

4. Define tiering criteria for a price component.
5. Define pricing eligibility criteria for a price component.
6. Click **Save**.

The price component is defined for a rate component.

### Related Topics

For more information on...	See...
<b>360–Degree Search</b> zone	<a href="#">360° Search</a>
How to search for a person.	<a href="#">Searching for a Person</a>
How to search for an account.	<a href="#">Searching for an Account</a>
<b>Search Price List</b> zone	<a href="#">Search Price List</a> on page 367
How to search for a price list.	<a href="#">Searching for a Price List</a> on page 371
<b>Rate Components</b> zone	<a href="#">Rate Components</a> on page 512
<b>Price Components</b> zone	<a href="#">Price Components</a> on page 512
How to define a tiering criteria for a price component.	<a href="#">Defining a Tiering Criteria for a Price Component</a> on page 527
How to define pricing eligibility criteria for a price component.	<a href="#">Defining a Pricing Eligibility Criteria for a Price Component</a> on page 530

## Defining a Tiering Criteria for a Price Component

### Prerequisites

To define a tiering criteria for a price component, you should have:

- Tiering criteria defined in the application
- Tiering setup for the rate components defined in the application.

### Procedure

To define a tiering criteria for a price component:

1. Click the **Add** link the right hand side corner of the **Tiering Criteria** zone.

#### **Note:**

The **Tiering Criteria** zone appears only when **Tiering Type** for the rate component is **STEP** or **Threshold**.

The **Price Component** screen appears. It contains the following fields:

Field Name	Field Description
Pricing Information	Displays the concatenated string consisting of pricing information and pricing ID which are separated by a colon (:) for an account, person or price list.

Field Name	Field Description
Rate Component Information	Displays a comma-separated string which consists of the following: <ul style="list-style-type: none"> <li>Rate Component Sequence</li> <li>Tiering Type of the Rate Component</li> </ul>

In addition, this screen contains the following sections:

- Main** – Used to specify the basic details about the price component.

This section contains the following fields:



Field Name	Field Description
Sequence	Indicates the sequence in which price component should be considered.
Show Price Component	Indicates that the price component will appear or not.
Description	Displays the description of the price component.
Rate Value	Indicates the rate defined for the price component.

- Tiering Criteria** – Used to specify the details of tiering criterions that are used in the tiering range.

This section contains the following fields:

Field Name	Field Description	Mandatory (Yes or No)
Sequence	Used to indicate the sequence in which tiering criteria should be considered.	Yes
Tiering Criterion	Used to select the tiering criterion which is used in the tiering range.	Yes
Lower Limit	Used to specify the lower limit of the pricing range.  <div style="border: 1px solid black; padding: 5px;"> <p><b>Note:</b> The system provides you with the facility to specify the lower limit value with a precision of up to 18 places before decimal and 18 places after decimal. This gives you the flexibility to specify very large and very low values in the tiering range.</p> </div>	Yes
Upper Limit	Used to specify the upper limit of the pricing range.  <div style="border: 1px solid black; padding: 5px;"> <p><b>Note:</b> The system provides you with the facility to specify the upper limit value with a precision of up to 18 places before decimal and 18 places after decimal. This gives you the flexibility to specify very large and very low values in the tiering range.  When you define single tier with the maximum value as blank (for example, 0 to BLANK), the system will automatically replace the blank space with 9999999999999999.99.</p> </div>	Yes



Field Name	Field Description	Mandatory (Yes or No)
Price Item	Used to Indicate whether the price item or price item bundle's total usage is considered for determining the rate. By default, the price item code for which you are defining the pricing appears in this field. You can specify any other price item or bundle code, if required.  <b>Note:</b> The <b>Search</b> (  ) icon appears corresponding to this field. On clicking the <b>Search</b> icon, the <b>Price Item Search</b> screen appears.	Yes
Price Item Parameters	Used to specify the parameters based on which price item or bundle's total usage should be considered for determining the rate. By default, the parameters based on which you are defining the pricing appear in this field. You can specify any other parameters (where the <b>Pricing</b> flag is set to <b>Yes</b> ), if required. However, note that you can only select parameters associated with the price item or bundle which is used for defining the tiering criteria.  <b>Note:</b> This field appears only when the <b>Multi Price Parameter</b> option type of the <b>Multi Parameter Based Pricing (C1_PPARM_FLG)</b> feature configuration is set to <b>True</b> .  The <b>Edit</b> (  ) appears corresponding to this field. On clicking the <b>Edit</b> icon, the <b>Parameters Search</b> screen appears.	No

- Enter the required details in the **Tiering Criteria** section.
- If you want to define more than one tiering criteria for the price component, click the **Add** () icon and then repeat step 2.

**Note:** However, if you want to remove a tiering criteria from the price component, click the **Delete** () icon corresponding to the tiering criterion.

- Click **Save**.

The tiering criteria is defined for the price component.

### **Related Topics**

For more information on...	See...
<b>360–Degree Search</b> zone	<a href="#">360° Search</a>
How to search for a person.	<a href="#">Searching for a Person</a>
How to search for an account.	<a href="#">Searching for an Account</a>
<b>Search Price List</b> zone	<a href="#">Search Price List</a> on page 367

For more information on...	See...
How to search for a price list.	<a href="#">Searching for a Price List</a> on page 371
<b>Rate Components</b> zone	<a href="#">Rate Components</a> on page 512
<b>Price Components</b> zone	<a href="#">Price Components</a> on page 512
How to define a price component for a rate component.	<a href="#">Defining a Price Component for a Rate Component</a> on page 524

## Defining a Pricing Eligibility Criteria for a Price Component

### Prerequisites

To define a pricing eligibility criteria for a price component, you should have:

- Pricing eligibility defined in the application

### Procedure

To define a pricing eligibility criteria for a price component:

1. Click the **Add** link the right hand side corner of the **Pricing Eligibility Criteria** zone.

#### **Note:**

The **Pricing Eligibility Criteria** zone appears only when eligibility checkbox is selected in the **Price Item Pricing** screen and details for pricing eligibility criteria is added in the **Price Component** screen.

The **Price Component** screen appears. It contains the following fields:

Field Name	Field Description
Pricing Information	Displays the concatenated string consisting of pricing information and pricing ID which are separated by a colon (:) for an account, person or price list.
Rate Component Information	Displays a comma-separated string which consists of the following: <ul style="list-style-type: none"> <li>• Rate Component Sequence</li> <li>• Tiering Type of the Rate Component</li> </ul>

In addition, this screen contains the following sections:

- **Main** – Used to specify the basic details about the price component.

This section contains the following fields:

Field Name	Field Description
Sequence	Indicates the sequence in which price component should be considered.
Show Price Component	Indicates that the price component will appear or not.
Description	Displays the description of the price component.
Rate Value	Indicates the rate defined for the price component.

- **Pricing Eligibility Criteria** – Used to specify the details of parameters used in the pricing eligibility criteria.

This section contains the following fields:

Column Name	Column Description	Mandatory (Yes or No)
Sequence	Used to indicate the order in which the criteria should be executed in the rule.	Yes
Parameter	<p>Used to indicate the left hand side parameter which you want to use along with the price item for price determination.</p> <div style="border: 1px solid black; padding: 5px;"> <p><b>Note:</b></p> <p>This field appears only when the <b>Multi Price Parameter</b> option type of the <b>Multi Parameter Based Pricing (C1_PPARAM_FLG)</b> feature configuration is set to <b>True</b>.</p> <p>The <b>Search</b> () icon appears corresponding to this field. On clicking the <b>Search</b> icon, the <b>Price Item Search</b> screen appears.</p> <p>You must not specify any special character except underscore (_) in the parameter code. Otherwise, the status of the transaction is changed to <b>Error (ERROR)</b>.</p> </div>	Yes
Operator	<p>Used to specify the relational operator to define the relation between the left hand side and right hand side parameters code. The valid values are:</p> <ul style="list-style-type: none"> <li>• &lt;</li> <li>• &lt;=</li> <li>• &lt;&gt;</li> <li>• =</li> <li>• &gt;</li> <li>• &gt;=</li> <li>• Algorithm</li> <li>• Between</li> <li>• In</li> <li>• Like</li> </ul>	Yes
Parameter Value Type	<p>Used to indicate the type of pricing eligibility. The valid values are:</p> <ul style="list-style-type: none"> <li>• <b>Parameter</b> – Used to indicate the type of parameter.</li> <li>• <b>Value</b> – Used to indicate the type of value.</li> </ul>	Yes

Column Name	Column Description	Mandatory (Yes or No)
Parameter Value	<p>When the <b>Parameter</b> option is selected for the <b>Parameter Value Type</b> field then it is used to specify the right hand side parameter which you want to use along with the price item for price determination. When the <b>Value</b> option is selected for the <b>Parameter Value Type</b> field then it is used to specify the parameter value.</p> <div style="border: 1px solid black; padding: 5px;"> <p><b>Note:</b></p> <p>This field appears only when the <b>Multi Price Parameter</b> option type of the <b>Multi Parameter Based Pricing (C1_PPARAM_FLG)</b> feature configuration is set to <b>True</b>.</p> <p>The <b>Search</b> () icon appears corresponding to this field only when the <b>Parameter</b> option is selected for <b>Parameter Value Type</b> field. On clicking the <b>Search</b> icon, the <b>Price Item Search</b> screen appears.</p> <p>When the <b>Parameter</b> option is selected for the <b>Parameter Value Type</b> field then you must not specify any special character except underscore (_) in the parameter code. Otherwise, the status of the transaction is changed to <b>Error (ERROR)</b>.</p> <p>When the <b>Value</b> option is selected for the <b>Parameter Value Type</b> field then you can specify any special characters except ampersand (&amp;), comma (,), underscore (_), equal to (=), tilde (~), and semi-colon (;) in the parameter value.</p> </div>	Yes
Is True	<p>Used to indicate what should happen when the condition is true (satisfied). The valid values are:</p> <ul style="list-style-type: none"> <li>• <b>Check Next Condition</b> – Used to indicate that the condition with consecutive sequence number should be executed.</li> <li>• <b>Rule Is False</b> – Used to indicate that the action specified in the <b>Rule False Action</b> field should be executed.</li> <li>• <b>Rule Is True</b> – Used to indicate that the action specified in the <b>Rule True Action</b> field should be executed.</li> </ul>	Yes

Column Name	Column Description	Mandatory (Yes or No)
Is False	Used to indicate what should happen when the condition is false (not satisfied). The valid values are: <ul style="list-style-type: none"> <li>• <b>Check Next Condition</b> – Used to indicate that the condition with consecutive sequence number should be executed.</li> <li>• <b>Rule Is False</b> – Used to indicate that the action specified in the <b>Rule False Action</b> field should be executed.</li> <li>• <b>Rule Is True</b> – Used to indicate that the action specified in the <b>Rule True Action</b> field should be executed.</li> </ul>	Yes
Is Insufficient	Used to indicate what should happen when the data is insufficient. The valid values are: <ul style="list-style-type: none"> <li>• <b>Check Next Condition</b> – Used to indicate that the condition with consecutive sequence number should be executed.</li> <li>• <b>Rule Is False</b> – Used to indicate that the action specified in the <b>Rule False Action</b> field should be executed.</li> <li>• <b>Rule Is True</b> – Used to indicate that the action specified in the <b>Rule True Action</b> field should be executed.</li> </ul>	Yes

- Enter the required details in the **Pricing Eligibility Criteria** section.
- If you want to define more than one pricing eligibility criteria for the price component, click the **Add (+)** icon and then repeat step 2.

**Note:** However, if you want to remove a pricing eligibility criteria from the price component, click the **Delete (🗑)** icon corresponding to the parameter.

- Click **Save**.

The pricing eligibility criteria is defined for the price component.

#### Related Topics

For more information on...	See...
<b>Rate Components</b> zone	<a href="#">Rate Components</a> on page 512
<b>Price Components</b> zone	<a href="#">Price Components</a> on page 512
<b>Tiering Criteria</b> zone	<a href="#">Tiering Criteria</a> on page 514
How to define a price component for a rate component.	<a href="#">Defining a Price Component for a Rate Component</a> on page 524

## Editing a Price Component

### Prerequisites

To edit a price component for a rate component, you should have:



- Rate component defined for the price item in the application

### Procedure

To edit a price component for a rate component:

1. Do either of the following:

If you want to edit...	Then...
Price components of Price Item Pricing assigned to an account	<ol style="list-style-type: none"> <li>1. Search for the account in the <b>Customer 360° View</b> screen.</li> <li>2. In the <b>Search Results</b> section, click the <b>Show Context Menu</b> (☰) icon corresponding to the account whose <i>details</i> you want to view. A menu appears.</li> <li>3. Click the <b>Go To Effective Pricing</b> menu option. The <b>Pricing (Account)</b> screen appears.</li> <li>4. Price assignments effective for the account appears in the <b>Effective Price Assignments for Account</b> zone.</li> <li>5. In the <b>Search Results</b> section, click the link in the <b>Pricing Information</b> column corresponding to the price item whose pricing details you want to view. The <b>Price Item Pricing</b> screen appears.</li> </ol> <div style="border: 1px solid black; padding: 5px; margin-top: 10px;"> <p><b>Tip:</b> Alternatively, you can access the <b>Price Item Pricing</b> screen by:</p> <ol style="list-style-type: none"> <li>1. Search for a price item in the <b>Search Price Item or Price Item Pricing</b> zone.</li> <li>2. In the <b>Search Results</b> section, click the <b>Assign</b> () icon corresponding to the price item.</li> <li>3. Enter the required details in the <b>Price Item Pricing</b> screen and click <b>Save</b>.</li> <li>4. The <b>Price Item Pricing</b> screen appears.</li> </ol> </div>
Price components of Price Item Pricing assigned to a person	<ol style="list-style-type: none"> <li>1. Search for the person in the <b>Customer 360° View</b> screen.</li> <li>2. In the <b>Search Results</b> section, click the <b>Show Context Menu</b> (☰) icon corresponding to the person whose <i>details</i> you want to view. A menu appears.</li> </ol>

If you want to edit...	Then...
	<p><b>3.</b> Click the <b>Go To Effective Pricing</b> menu option.</p> <p>The <b>Pricing (Person)</b> screen appears.</p> <p><b>4.</b> Price assignments effective for the person appears in the <b>Effective Price Assignments for Person</b> zone.</p> <p><b>5.</b> In the <b>Search Results</b> section, click the link in the <b>Pricing Information</b> column corresponding to the price item whose pricing details you want to view.</p> <p>The <b>Price Item Pricing</b> screen appears.</p> <div style="border: 1px solid black; padding: 5px; margin-top: 10px;"> <p><b>Tip:</b> Alternatively, you can access the <b>Price Item Pricing</b> screen by:</p> <p><b>1.</b> Search for a price item in the <b>Search Price Item or Price Item Pricing</b> zone.</p> <p><b>2.</b> In the <b>Search Results</b> section, click the <b>Assign</b> () icon corresponding to the price item.</p> <p><b>3.</b> Enter the required details in the <b>Price Item Pricing</b> screen and click <b>Save</b>.</p> <p><b>4.</b> The <b>Price Item Pricing</b> screen appears.</p> </div>
Price components of Price Item Pricing assigned to a price list	<p><b>1.</b> Search for the price list in the <b>Price List</b> screen.</p> <p><b>2.</b> In the <b>Search Results</b> section, click the <b>Price List Pricing</b> () icon corresponding to the price list whose details you want to view.</p> <p>The <b>Price List Price Item Pricing</b> screen appears.</p> <p><b>3.</b> Price items assigned to the price list appears in the <b>Price List Price Items</b> zone.</p> <p><b>4.</b> In the <b>Search Results</b> section, click the link in the <b>Pricing Information</b> column corresponding to the price item whose pricing details you want to view.</p> <p>The <b>Price Item Pricing</b> screen appears.</p>

If you want to edit...	Then...
	<p><b>Tip:</b> Alternatively, you can access the <b>Price Item Pricing</b> screen by:</p> <ol style="list-style-type: none"> <li>1. Search for a price item in the <b>Search Price Item or Price Item Pricing</b> zone.</li> <li>2. In the <b>Search Results</b> section, click the <b>Assign</b> () icon corresponding to the price item.</li> <li>3. Enter the required details in the <b>Price Item Pricing</b> screen and click <b>Save</b>.</li> <li>4. The <b>Price Item Pricing</b> screen appears.</li> </ol>

2. In the **Rate Components** zone, click the **Broadcast** () icon corresponding to the rate component, the **Price Components** zone appears with the details of the price components for the respective rate component.

3. Click the **Edit** () icon in the **Edit** column corresponding to the price component whose details you want to edit for the rate component.

The **Price Component** screen appears. It contains the following fields:

Field Name	Field Description
Pricing Information	Displays the concatenated string consisting of pricing information and pricing ID which are separated by a colon (:) for an account, person or price list.
Rate Component Information	Displays a comma-separated string which consists of the following: <ul style="list-style-type: none"> <li>• Rate Component Sequence</li> <li>• Tiering Type of the Rate Component</li> </ul>

In addition, this screen contains the following sections:

- **Main** – Used to specify the basic details about the price component.
- **Tiering Criteria** – Used to specify the details of tiering criterions that are used in the tiering range.
- **Pricing Eligibility Criteria** – Used to specify the details of parameters used while defining the pricing eligibility criteria.

The **Main** section contains the following fields:

Field Name	Field Description	Mandatory (Yes or No)
Sequence	Used to indicate the sequence in which price component is to be considered.	Yes
Show Price Component	Used to indicate whether the price component must appear or not.	Yes
Description	Used to specify the description of the price component.	Yes
Rate Value	Used to indicate the rate defined for the price component.	Yes



4. Modify the required details in the **Main** section.
5. Modify the tiering criteria for a price component.
6. Modify the pricing eligibility criteria for a price component.
7. Click **Save**.

The price component is edited for a rate component.

### Related Topics

For more information on...	See...
<b>360° Search</b> zone	<a href="#">360° Search</a>
How to search for a person.	<a href="#">Searching for a Person</a>
How to search for an account.	<a href="#">Searching for an Account</a>
<b>Search Price List</b> zone	<a href="#">Search Price List</a> on page 367
How to search for a price list.	<a href="#">Searching for a Price List</a> on page 371
<b>Rate Components</b> zone	<a href="#">Rate Components</a> on page 512
<b>Price Components</b> zone	<a href="#">Price Components</a> on page 512
How to define a price component for a rate component	<a href="#">Defining a Price Component for a Rate Component</a> on page 524
How to edit a tiering criteria for a price component.	<a href="#">Editing a Tiering Criteria of a Price Component</a> on page 540
How to edit a pricing eligibility criteria for a price component.	<a href="#">Editing a Pricing Eligibility Criteria of a Price Component</a> on page 547

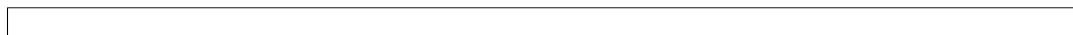



## Deleting a Price Component



### Procedure



To delete a price component:

1. Do either of the following:

If you want to delete...	Then...
Price components of Price Item Pricing assigned to an account	<ol style="list-style-type: none"> <li>1. Search for the account in the <b>Customer 360° View</b> screen.</li> <li>2. In the <b>Search Results</b> section, click the <b>Show Context Menu</b> (☰) icon corresponding to the account whose <i>details</i> you want to view. A menu appears.</li> <li>3. Click the <b>Go To Effective Pricing</b> menu option. The <b>Pricing (Account)</b> screen appears.</li> <li>4. Price assignments effective for the account appears in the <b>Effective Price Assignments for Account</b> zone.</li> </ol>

If you want to delete...	Then...
	<p>5. In the <b>Search Results</b> section, click the link in the <b>Pricing Information</b> column corresponding to the price item whose pricing details you want to view.</p> <p>The <b>Price Item Pricing</b> screen appears.</p> <div style="border: 1px solid black; padding: 5px; margin-top: 10px;"> <p><b>Tip:</b> Alternatively, you can access the <b>Price Item Pricing</b> screen by:</p> <ol style="list-style-type: none"> <li>1. Search for a price item in the <b>Search Price Item or Price Item Pricing</b> zone.</li> <li>2. In the <b>Search Results</b> section, click the <b>Assign</b> () icon corresponding to the price item.</li> <li>3. Enter the required details in the <b>Price Item Pricing</b> screen and click <b>Save</b>.</li> <li>4. The <b>Price Item Pricing</b> screen appears.</li> </ol> </div>
Price components of Price Item Pricing assigned to a person	<ol style="list-style-type: none"> <li>1. Search for the person in the <b>Customer 360° View</b> screen.</li> <li>2. In the <b>Search Results</b> section, click the <b>Show Context Menu</b> () icon corresponding to the person whose details you want to view.</li> </ol> <p>A menu appears.</p> <ol style="list-style-type: none"> <li>3. Click the <b>Go To Effective Pricing</b> menu option.</li> </ol> <p>The <b>Pricing (Person)</b> screen appears.</p> <ol style="list-style-type: none"> <li>4. Price assignments effective for the person appears in the <b>Effective Price Assignments for Person</b> zone.</li> <li>5. In the <b>Search Results</b> section, click the link in the <b>Pricing Information</b> column corresponding to the price item whose pricing details you want to view.</li> </ol> <p>The <b>Price Item Pricing</b> screen appears.</p> <div style="border: 1px solid black; padding: 5px; margin-top: 10px;"> <p><b>Tip:</b> Alternatively, you can access the <b>Price Item Pricing</b> screen by:</p> <ol style="list-style-type: none"> <li>1. Search for a price item in the <b>Search Price Item or Price Item Pricing</b> zone.</li> <li>2. In the <b>Search Results</b> section, click the <b>Assign</b> () icon corresponding to the price item.</li> <li>3. Enter the required details in the <b>Price Item Pricing</b> screen and click <b>Save</b>.</li> <li>4. The <b>Price Item Pricing</b> screen appears.</li> </ol> </div>

If you want to delete...	Then...
Price components of Price Item Pricing assigned to a price list	<ol style="list-style-type: none"> <li>1. Search for the price list in the <b>Price List</b> screen.</li> <li>2. In the <b>Search Results</b> section, click the <b>Price List Pricing</b> () icon corresponding to the price list whose details you want to view. The <b>Price List Price Item Pricing</b> screen appears.</li> <li>3. Price items assigned to the price list appears in the <b>Price List Price Items</b> zone.</li> <li>4. In the <b>Search Results</b> section, click the link in the <b>Pricing Information</b> column corresponding to the price item whose pricing details you want to view. The <b>Price Item Pricing</b> screen appears.</li> </ol> <div style="border: 1px solid black; padding: 5px; margin-top: 10px;"> <p><b>Tip:</b> Alternatively, you can access the <b>Price Item Pricing</b> screen by:</p> <ol style="list-style-type: none"> <li>1. Search for a price item in the <b>Search Price Item or Price Item Pricing</b> zone.</li> <li>2. In the <b>Search Results</b> section, click the <b>Assign</b> () icon corresponding to the price item.</li> <li>3. Enter the required details in the <b>Price Item Pricing</b> screen and click <b>Save</b>.</li> <li>4. The <b>Price Item Pricing</b> screen appears.</li> </ol> </div>

2. In the **Rate Components** zone, click the **Broadcast** () icon corresponding to the rate component, the **Price Components** zone appears with the details of the price components for the respective rate component.
3. Click the **Delete** () icon in the **Delete** column corresponding to the price component that you want to remove for the rate component.

**Note:** The **Delete** icon appears only when the price assignment is in **Draft, Proposed** or **Template** status.

A message appears confirming whether you want to remove the price component for the rate component.

4. Click **OK**.  
The price component is removed for the rate component.

### **Related Topics**

For more information on...	See...
<b>Rate Components</b> zone	<a href="#">Rate Components</a> on page 512
<b>Price Components</b> zone	<a href="#">Price Components</a> on page 512
How to view price components of a rate component.	<a href="#">Viewing the Price Components of a Rate Component</a> on page 519

For more information on...	See...
How to define a price component for a rate component.	<a href="#">Defining a Price Component for a Rate Component</a> on page 524

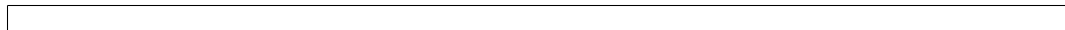

## Editing a Tiering Criteria of a Price Component

### Prerequisites



To edit a tiering criteria for a price component, you should have:



- Tiering criteria defined in the application
- Tiering setup for the rate components defined in the application.

### Procedure



To edit a tiering criteria of a price component:

1. Do either of the following:

If you want to edit the tiering criteria of.....	Then...
Price components of Price Item Pricing assigned to an account	<ol style="list-style-type: none"> <li>1. Search for the account in the <b>Customer 360° View</b> screen.</li> <li>2. In the <b>Search Results</b> section, click the <b>Show Context Menu</b> () icon corresponding to the account whose <i>details</i> you want to view. A menu appears.</li> <li>3. Click the <b>Go To Effective Pricing</b> menu option. The <b>Pricing (Account)</b> screen appears.</li> <li>4. Price assignments effective for the account appears in the <b>Effective Price Assignments for Account</b> zone.</li> <li>5. In the <b>Search Results</b> section, click the link in the <b>Pricing Information</b> column corresponding to the price item whose pricing details you want to view. The <b>Price Item Pricing</b> screen appears.</li> </ol> <div style="border: 1px solid black; padding: 5px; margin-top: 10px;"> <p><b>Tip:</b> Alternatively, you can access the <b>Price Item Pricing</b> screen by:</p> <ol style="list-style-type: none"> <li>1. Search for a price item in the <b>Search Price Item or Price Item Pricing</b> zone.</li> <li>2. In the <b>Search Results</b> section, click the <b>Assign</b> () icon corresponding to the price item.</li> <li>3. Enter the required details in the <b>Price Item Pricing</b> screen and click <b>Save</b>.</li> <li>4. The <b>Price Item Pricing</b> screen appears.</li> </ol> </div>

If you want to edit the tiering criteria of.....	Then...
Price components of Price Item Pricing assigned to a person	<ol style="list-style-type: none"> <li>1. Search for the person in the <b>Customer 360° View</b> screen.</li> <li>2. In the <b>Search Results</b> section, click the <b>Show Context Menu</b> () icon corresponding to the person whose <i>details</i> you want to view. A menu appears.</li> <li>3. Click the <b>Go To Effective Pricing</b> menu option. The <b>Pricing (Person)</b> screen appears.</li> <li>4. Price assignments effective for the person appears in the <b>Effective Price Assignments for Person</b> zone.</li> <li>5. In the <b>Search Results</b> section, click the link in the <b>Pricing Information</b> column corresponding to the price item whose pricing details you want to view. The <b>Price Item Pricing</b> screen appears.</li> </ol> <div style="border: 1px solid black; padding: 5px; margin-top: 10px;"> <p><b>Tip:</b> Alternatively, you can access the <b>Price Item Pricing</b> screen by:</p> <ol style="list-style-type: none"> <li>1. Search for a price item in the <b>Search Price Item or Price Item Pricing</b> zone.</li> <li>2. In the <b>Search Results</b> section, click the <b>Assign</b> () icon corresponding to the price item.</li> <li>3. Enter the required details in the <b>Price Item Pricing</b> screen and click <b>Save</b>.</li> <li>4. The <b>Price Item Pricing</b> screen appears.</li> </ol> </div>
Price components of Price Item Pricing assigned to a price list	<ol style="list-style-type: none"> <li>1. Search for the price list in the <b>Price List</b> screen.</li> <li>2. In the <b>Search Results</b> section, click the <b>Price List Pricing</b> () icon corresponding to the price list whose <i>details</i> you want to view. The <b>Price List Price Item Pricing</b> screen appears.</li> <li>3. Price items assigned to the price list appears in the <b>Price List Price Items</b> zone.</li> <li>4. In the <b>Search Results</b> section, click the link in the <b>Pricing Information</b> column corresponding to the price item whose pricing details you want to view. The <b>Price Item Pricing</b> screen appears.</li> </ol>

If you want to edit the tiering criteria of.....	Then...
	<p><b>Tip:</b> Alternatively, you can access the <b>Price Item Pricing</b> screen by:</p> <ol style="list-style-type: none"> <li>1. Search for a price item in the <b>Search Price Item or Price Item Pricing</b> zone.</li> <li>2. In the <b>Search Results</b> section, click the <b>Assign</b> () icon corresponding to the price item.</li> <li>3. Enter the required details in the <b>Price Item Pricing</b> screen and click <b>Save</b>.</li> <li>4. The <b>Price Item Pricing</b> screen appears.</li> </ol>

2. In the **Rate Components** zone, click the **Broadcast** () icon corresponding to the rate component, the **Price Components** zone appears with the details of the price components for the respective rate component.
3. In the **Price Components** zone, click the **Broadcast** () icon corresponding to the price component, the **Tiering Criteria** zone appears with the details of tiering criterions that are used in the tiering range.

**Note:**

The **Tiering Criteria** zone appears only when **Tiering Type** for the rate component is **STEP** or **Threshold**.

4. Click the **Edit** () icon in the **Edit** column corresponding to the tiering criteria whose details you want to edit for the price component.

The **Price Component** screen appears. It contains the following fields:

Field Name	Field Description
Pricing Information	Displays the concatenated string consisting of pricing information and pricing ID which are separated by a colon (:) for an account, person or price list.
Rate Component Information	Displays a comma-separated string which consists of the following: <ul style="list-style-type: none"> <li>• Rate Component Sequence</li> <li>• Tiering Type of the Rate Component</li> </ul>

In addition, this screen contains the following sections:

- **Main** – Used to specify the basic details about the price component.

This section contains the following fields:

Field Name	Field Description
Sequence	Indicates the sequence in which price component should be considered.
Show Price Component	Indicates that the price component will appear or not.
Description	Displays the description of the price component.
Rate Value	Indicates the rate defined for the price component.

- **Tiering Criteria** – Used to specify the details of tiering criteria that are used in the tiering range.

This section contains the following fields:

Field Name	Field Description	Mandatory (Yes or No)
Sequence	Used to indicate the sequence in which tiering criteria is to be considered.	Yes
Tiering Criterion	Used to select the tiering criterion which is used in the tiering range.	Yes
Lower Limit	Used to specify the lower limit of the pricing range.  <b>Note:</b> The system provides you with the facility to specify the lower limit value with a precision of up to 18 places before decimal and 18 places after decimal. This gives you the flexibility to specify very large and very low values in the tiering range.	Yes
Upper Limit	Used to specify the upper limit of the pricing range.  <b>Note:</b> The system provides you with the facility to specify the upper limit value with a precision of up to 18 places before decimal and 18 places after decimal. This gives you the flexibility to specify very large and very low values in the tiering range.  When you define single tier with the maximum value as blank (for example, 0 to BLANK), the system will automatically replace the blank space with 9999999999999999.99.	Yes
Price Item	Used to Indicate whether the price item or price item bundle's total usage is considered for determining the rate. By default, the price item code for which you defined the pricing appears in this field. You can specify any other price item or bundle code, if required.  <b>Note:</b> The <b>Search</b>  icon appears corresponding to this field. On clicking the <b>Search</b> icon, the <b>Price Item Search</b> screen appears.	Yes

Field Name	Field Description	Mandatory (Yes or No)
Price Item Parameters	<p>Used to specify the parameters based on which price item or bundle's total usage should be considered for determining the rate. By default, the parameters based on which you are defining the pricing appear in this field. You can specify any other parameters (where the <b>Pricing</b> flag is set to <b>Yes</b>), if required. However, note that you can only select parameters associated with the price item or bundle which is used for defining the tiering criteria.</p> <div style="border: 1px solid black; padding: 5px;"> <p><b>Note:</b></p> <p>This field appears only when the <b>Multi Price Parameter</b> option type of the <b>Multi Parameter Based Pricing (C1_PPARM_FLG)</b> feature configuration is set to <b>True</b>.</p> <p>The <b>Edit</b> () appears corresponding to this field. On clicking the <b>Edit</b> icon, the <b>Parameters Search</b> screen appears.</p> </div>	No

5. Modify the tiering criteria for a price component.

6. Click **Save**.

The tiering criteria is edited for a price component.

### Related Topics

For more information on...	See...
<b>360° Search</b> zone	<a href="#">360° Search</a>
How to search for a person.	<a href="#">Searching for a Person</a>
How to search for an account.	<a href="#">Searching for an Account</a>
<b>Search Price List</b> zone	<a href="#">Search Price List</a> on page 367
How to search for a price list.	<a href="#">Searching for a Price List</a> on page 371
<b>Rate Components</b> zone	<a href="#">Rate Components</a> on page 512
<b>Price Components</b> zone	<a href="#">Price Components</a> on page 512
How to define a price component for a rate component	<a href="#">Defining a Price Component for a Rate Component</a> on page 524
How to define a tiering criteria for a price component.	<a href="#">Defining a Tiering Criteria for a Price Component</a> on page 527



## Deleting a Tiering Criteria of a Price Component



### Procedure



To delete a tiering criteria of a price component:



## 1. Do either of the following:

If you want to delete tiering criteria of...	Then...
Price components of Price Item Pricing assigned to an account	<ol style="list-style-type: none"> <li>1. Search for the account in the <b>Customer 360° View</b> screen.</li> <li>2. In the <b>Search Results</b> section, click the <b>Show Context Menu</b> () icon corresponding to the account whose <i>details</i> you want to view. A menu appears.</li> <li>3. Click the <b>Go To Effective Pricing</b> menu option. The <b>Pricing (Account)</b> screen appears.</li> <li>4. Price assignments effective for the account appears in the <b>Effective Price Assignments for Account</b> zone.</li> <li>5. In the <b>Search Results</b> section, click the link in the <b>Pricing Information</b> column corresponding to the price item whose pricing details you want to view. The <b>Price Item Pricing</b> screen appears.</li> </ol> <div style="border: 1px solid black; padding: 5px; margin-top: 10px;"> <p><b>Tip:</b> Alternatively, you can access the <b>Price Item Pricing</b> screen by:</p> <ol style="list-style-type: none"> <li>1. Search for a price item in the <b>Search Price Item or Price Item Pricing</b> zone.</li> <li>2. In the <b>Search Results</b> section, click the <b>Assign</b> () icon corresponding to the price item.</li> <li>3. Enter the required details in the <b>Price Item Pricing</b> screen and click <b>Save</b>.</li> <li>4. The <b>Price Item Pricing</b> screen appears.</li> </ol> </div>
Price components of Price Item Pricing assigned to a person	<ol style="list-style-type: none"> <li>1. Search for the person in the <b>Customer 360° View</b> screen.</li> <li>2. In the <b>Search Results</b> section, click the <b>Show Context Menu</b> () icon corresponding to the person whose <i>details</i> you want to view. A menu appears.</li> <li>3. Click the <b>Go To Effective Pricing</b> menu option. The <b>Pricing (Person)</b> screen appears.</li> <li>4. Price assignments effective for the person appears in the <b>Effective Price Assignments for Person</b> zone.</li> <li>5. In the <b>Search Results</b> section, click the link in the <b>Pricing Information</b> column corresponding to the price item whose pricing details you want to view.</li> </ol>

If you want to delete tiering criteria of...	Then...
	<p>The <b>Price Item Pricing</b> screen appears.</p> <p><b>Tip:</b> Alternatively, you can access the <b>Price Item Pricing</b> screen by:</p> <ol style="list-style-type: none"> <li>1. Search for a price item in the <b>Search Price Item or Price Item Pricing</b> zone.</li> <li>2. In the <b>Search Results</b> section, click the <b>Assign</b> () icon corresponding to the price item.</li> <li>3. Enter the required details in the <b>Price Item Pricing</b> screen and click <b>Save</b>.</li> <li>4. The <b>Price Item Pricing</b> screen appears.</li> </ol>
Price components of Price Item Pricing assigned to a price list	<ol style="list-style-type: none"> <li>1. Search for the price list in the <b>Price List</b> screen.</li> <li>2. In the <b>Search Results</b> section, click the <b>Price List Pricing</b> () icon corresponding to the price list whose <i>details</i> you want to view. The <b>Price List Price Item Pricing</b> screen appears.</li> <li>3. Price items assigned to the price list appears in the <b>Price List Price Items</b> zone.</li> <li>4. In the <b>Search Results</b> section, click the link in the <b>Pricing Information</b> column corresponding to the price item whose pricing details you want to view. The <b>Price Item Pricing</b> screen appears.</li> </ol> <p><b>Tip:</b> Alternatively, you can access the <b>Price Item Pricing</b> screen by:</p> <ol style="list-style-type: none"> <li>1. Search for a price item in the <b>Search Price Item or Price Item Pricing</b> zone.</li> <li>2. In the <b>Search Results</b> section, click the <b>Assign</b> () icon corresponding to the price item.</li> <li>3. Enter the required details in the <b>Price Item Pricing</b> screen and click <b>Save</b>.</li> <li>4. The <b>Price Item Pricing</b> screen appears.</li> </ol>

2. In the **Rate Components** zone, click the **Broadcast** () icon corresponding to the rate component, the **Price Components** zone appears with the details of the price components for the respective rate component.
3. In the **Price Components** zone, click the **Broadcast** () icon corresponding to the price component, the **Tiering Criteria** zone appears with the details of tiering criterions that are used in the tiering range.

**Note:**

The **Tiering Criteria** zone appears only when **Tiering Type** for the rate component is **STEP** or **Threshold**.

- Click the **Delete** (🗑️) icon in the **Delete** column corresponding to the tiering criteria that you want to remove for the price component.

**Note:** The **Delete** icon appears only when the price assignment is in **Draft**, **Proposed** or **Template** status.

A message appears confirming whether you want to remove the tiering criteria of a price component.

- Click **OK**.

The tiering criteria is removed for the price component.

**Related Topics**

For more information on...	See...
<b>Rate Components</b> zone	<a href="#">Rate Components</a> on page 512
<b>Price Components</b> zone	<a href="#">Price Components</a> on page 512
<b>Tiering Criteria</b> zone	<a href="#">Tiering Criteria</a> on page 514
How to view tiering criteria of a price component.	<a href="#">Viewing the Tiering Criteria of a Price Component</a> on page 520
How to define a tiering criteria for a price component.	<a href="#">Defining a Tiering Criteria for a Price Component</a> on page 527

**Editing a Pricing Eligibility Criteria of a Price Component****Prerequisites**

To edit a pricing eligibility criteria for a price component, you should have:



- Pricing eligibility defined in the application



**Procedure**



To edit a pricing eligibility criteria of a price component:

- Do either of the following:

If you want to edit the pricing eligibility criteria of.....	Then...
Price components of Price Item Pricing assigned to an account	<ol style="list-style-type: none"> <li>Search for the account in the <b>Customer 360° View</b> screen.</li> <li>In the <b>Search Results</b> section, click the <b>Show Context Menu</b> (☰) icon corresponding to the account whose <i>details</i> you want to view. A menu appears.</li> <li>Click the <b>Go To Effective Pricing</b> menu option. The <b>Pricing (Account)</b> screen appears.</li> </ol>

If you want to edit the pricing eligibility criteria of.....	Then...
	<p>4. Price assignments effective for the account appears in the <b>Effective Price Assignments for Account</b> zone.</p> <p>5. In the <b>Search Results</b> section, click the link in the <b>Pricing Information</b> column corresponding to the price item whose pricing details you want to view.</p> <p>The <b>Price Item Pricing</b> screen appears.</p> <p><b>Tip:</b> Alternatively, you can access the <b>Price Item Pricing</b> screen by:</p> <ol style="list-style-type: none"> <li>1. Search for a price item in the <b>Search Price Item or Price Item Pricing</b> zone.</li> <li>2. In the <b>Search Results</b> section, click the <b>Assign</b> () icon corresponding to the price item.</li> <li>3. Enter the required details in the <b>Price Item Pricing</b> screen and click <b>Save</b>.</li> <li>4. The <b>Price Item Pricing</b> screen appears.</li> </ol>
Price components of Price Item Pricing assigned to a person	<ol style="list-style-type: none"> <li>1. Search for the person in the <b>Customer 360° View</b> screen.</li> <li>2. In the <b>Search Results</b> section, click the <b>Show Context Menu</b> () icon corresponding to the person whose details you want to view.</li> </ol> <p>A menu appears.</p> <ol style="list-style-type: none"> <li>3. Click the <b>Go To Effective Pricing</b> menu option.</li> </ol> <p>The <b>Pricing (Person)</b> screen appears.</p> <ol style="list-style-type: none"> <li>4. Price assignments effective for the person appears in the <b>Effective Price Assignments for Person</b> zone.</li> <li>5. In the <b>Search Results</b> section, click the link in the <b>Pricing Information</b> column corresponding to the price item whose pricing details you want to view.</li> </ol> <p>The <b>Price Item Pricing</b> screen appears.</p>

If you want to edit the pricing eligibility criteria of.....	Then...
	<p><b>Tip:</b> Alternatively, you can access the <b>Price Item Pricing</b> screen by:</p> <ol style="list-style-type: none"> <li>1. Search for a price item in the <b>Search Price Item or Price Item Pricing</b> zone.</li> <li>2. In the <b>Search Results</b> section, click the <b>Assign</b> () icon corresponding to the price item.</li> <li>3. Enter the required details in the <b>Price Item Pricing</b> screen and click <b>Save</b>.</li> <li>4. The <b>Price Item Pricing</b> screen appears.</li> </ol>
Price components of Price Item Pricing assigned to a price list	<ol style="list-style-type: none"> <li>1. Search for the price list in the <b>Price List</b> screen.</li> <li>2. In the <b>Search Results</b> section, click the <b>Price List Pricing</b> () icon corresponding to the price list whose details you want to view.  The <b>Price List Price Item Pricing</b> screen appears.</li> <li>3. Price items assigned to the price list appears in the <b>Price List Price Items</b> zone.</li> <li>4. In the <b>Search Results</b> section, click the link in the <b>Pricing Information</b> column corresponding to the price item whose pricing details you want to view.  The <b>Price Item Pricing</b> screen appears.</li> </ol> <p><b>Tip:</b> Alternatively, you can access the <b>Price Item Pricing</b> screen by:</p> <ol style="list-style-type: none"> <li>1. Search for a price item in the <b>Search Price Item or Price Item Pricing</b> zone.</li> <li>2. In the <b>Search Results</b> section, click the <b>Assign</b> () icon corresponding to the price item.</li> <li>3. Enter the required details in the <b>Price Item Pricing</b> screen and click <b>Save</b>.</li> <li>4. The <b>Price Item Pricing</b> screen appears.</li> </ol>

2. In the **Rate Components** zone, click the **Broadcast** () icon corresponding to the rate component, the **Price Components** zone appears with the details of the price components for the respective rate component.
3. In the **Price Components** zone, click the **Broadcast** () icon corresponding to the price component, the **Pricing Eligibility Criteria** zone appears with the details of parameters used in the pricing eligibility criteria.

**Note:**

The **Pricing Eligibility Criteria** zone appears only when eligibility checkbox is selected in the **Price Item Pricing** screen and details for pricing eligibility criteria is added in the **Price Component** screen.

4. Click the **Edit** (  ) icon in the **Edit** column corresponding to the parameter whose pricing eligibility criteria details you want to edit for the price component.

The **Price Component** screen appears. It contains the following fields:

Field Name	Field Description
Pricing Information	Displays the concatenated string consisting of pricing information and pricing ID which are separated by a colon (:) for an account, person or price list.
Rate Component Information	Displays a comma-separated string which consists of the following: <ul style="list-style-type: none"> <li>• Rate Component Sequence</li> <li>• Tiering Type of the Rate Component</li> </ul>

In addition, this screen contains the following sections:

- **Main** – Used to specify the basic details about the price component.

This section contains the following fields:

Field Name	Field Description
Sequence	Indicates the sequence in which price component should be considered.
Show Price Component	Indicates that the price component will appear or not.
Description	Displays the description of the price component.
Rate Value	Indicates the rate defined for the price component.

- **Pricing Eligibility Criteria** – Used to specify the details of parameters used in the pricing eligibility criteria.

This section contains the following fields:

Column Name	Column Description	Mandatory (Yes or No)
Sequence	Used to indicate the order in which the criteria to be executed in the rule.	Yes

Column Name	Column Description	Mandatory (Yes or No)
Parameter	<p>Used to indicate the left hand side parameter which you want to use along with the price item for price determination.</p> <div style="border: 1px solid black; padding: 5px;"> <p><b>Note:</b></p> <p>This field appears only when the <b>Multi Price Parameter</b> option type of the <b>Multi Parameter Based Pricing (C1_PPARAM_FLG)</b> feature configuration is set to <b>True</b>.</p> <p>The <b>Search</b> (🔍) icon appears corresponding to this field. On clicking the <b>Search</b> icon, the <b>Price Item Search</b> screen appears.</p> <p>You must not specify any special character except underscore (_) in the parameter code. Otherwise, the status of the transaction is changed to <b>Error (ERROR)</b>.</p> </div>	Yes
Operator	<p>Used to specify the relational operator to define the relation between the left hand side and right hand side parameters code. The valid values are:</p> <ul style="list-style-type: none"> <li>• &lt;</li> <li>• &lt;=</li> <li>• &lt;&gt;</li> <li>• =</li> <li>• &gt;</li> <li>• &gt;=</li> <li>• Algorithm</li> <li>• Between</li> <li>• In</li> <li>• Like</li> </ul>	Yes
Parameter Value Type	<p>Used to indicate the type of pricing eligibility. The valid values are:</p> <ul style="list-style-type: none"> <li>• <b>Parameter</b> – Used to indicate the type of parameter.</li> <li>• <b>Value</b> – Used to indicate the type of value.</li> </ul>	Yes

Column Name	Column Description	Mandatory (Yes or No)
Parameter Value	<p>When the <b>Parameter</b> option is selected for the <b>Parameter Value Type</b> field then it is used to specify the right hand side parameter which you want to use along with the price item for price determination. When the <b>Value</b> option is selected for the <b>Parameter Value Type</b> field then it is used to specify the parameter value.</p> <div style="border: 1px solid black; padding: 5px;"> <p><b>Note:</b></p> <p>This field appears only when the <b>Multi Price Parameter</b> option type of the <b>Multi Parameter Based Pricing (C1_PPARAM_FLG)</b> feature configuration is set to <b>True</b>.</p> <p>The <b>Search</b> () icon appears corresponding to this field only when the <b>Parameter</b> option is selected for <b>Parameter Value Type</b> field. On clicking the <b>Search</b> icon, the <b>Price Item Search</b> screen appears.</p> <p>When the <b>Parameter</b> option is selected for the <b>Parameter Value Type</b> field then you must not specify any special character except underscore (_) in the parameter code. Otherwise, the status of the transaction is changed to <b>Error (ERROR)</b>.</p> <p>When the <b>Value</b> option is selected for the <b>Parameter Value Type</b> field then you can specify any special characters except ampersand (&amp;), comma (,), underscore (_), equal to (=), tilde (~), and semi-colon (;) in the parameter value.</p> </div>	Yes
Is True	<p>Used to indicate what should happen when the condition is true (satisfied). The valid values are:</p> <ul style="list-style-type: none"> <li>• <b>Check Next Condition</b> – Used to indicate that the condition with consecutive sequence number should be executed.</li> <li>• <b>Rule Is False</b> – Used to indicate that the action specified in the <b>Rule False Action</b> field should be executed.</li> <li>• <b>Rule Is True</b> – Used to indicate that the action specified in the <b>Rule True Action</b> field should be executed.</li> </ul>	Yes



Column Name	Column Description	Mandatory (Yes or No)
Is False	Used to indicate what should happen when the condition is false (not satisfied). The valid values are: <ul style="list-style-type: none"> <li>• <b>Check Next Condition</b> – Used to indicate that the condition with consecutive sequence number should be executed.</li> <li>• <b>Rule Is False</b> – Used to indicate that the action specified in the <b>Rule False Action</b> field should be executed.</li> <li>• <b>Rule Is True</b> – Used to indicate that the action specified in the <b>Rule True Action</b> field should be executed.</li> </ul>	Yes
Is Insufficient	Used to indicate what should happen when the data is insufficient. The valid values are: <ul style="list-style-type: none"> <li>• <b>Check Next Condition</b> – Used to indicate that the condition with consecutive sequence number should be executed.</li> <li>• <b>Rule Is False</b> – Used to indicate that the action specified in the <b>Rule False Action</b> field should be executed.</li> <li>• <b>Rule Is True</b> – Used to indicate that the action specified in the <b>Rule True Action</b> field should be executed.</li> </ul>	Yes

5. Modify the pricing eligibility criteria for a price component.

6. Click **Save**.

The pricing eligibility criteria is edited for a price component.

### **Related Topics**

For more information on...	See...
<b>360° Search</b> zone	<a href="#">360° Search</a>
How to search for a person.	<a href="#">Searching for a Person</a>
How to search for an account.	<a href="#">Searching for an Account</a>
<b>Search Price List</b> zone	<a href="#">Search Price List</a> on page 367
How to search for a price list.	<a href="#">Searching for a Price List</a> on page 371
<b>Rate Components</b> zone	<a href="#">Rate Components</a> on page 512
<b>Price Components</b> zone	<a href="#">Price Components</a> on page 512
How to define a price component for a rate component	<a href="#">Defining a Price Component for a Rate Component</a> on page 524
How to define a pricing eligibility criteria for a price component	<a href="#">Defining a Pricing Eligibility Criteria for a Price Component</a> on page 530



## Deleting a Pricing Eligibility Criteria of a Price Component

### Procedure



To delete a pricing eligibility criteria of a price component:

1. Do either of the following:

If you want to delete pricing eligibility criteria of...	Then...
Price components of Price Item Pricing assigned to an account	<ol style="list-style-type: none"> <li>1. Search for the account in the <b>Customer 360° View</b> screen.</li> <li>2. In the <b>Search Results</b> section, click the <b>Show Context Menu</b> (☰) icon corresponding to the account whose <i>details</i> you want to view. A menu appears.</li> <li>3. Click the <b>Go To Effective Pricing</b> menu option. The <b>Pricing (Account)</b> screen appears.</li> <li>4. Price assignments effective for the account appears in the <b>Effective Price Assignments for Account</b> zone.</li> <li>5. In the <b>Search Results</b> section, click the link in the <b>Pricing Information</b> column corresponding to the price item whose pricing details you want to view. The <b>Price Item Pricing</b> screen appears.</li> </ol> <div style="border: 1px solid black; padding: 5px; margin-top: 10px;"> <p><b>Tip:</b> Alternatively, you can access the <b>Price Item Pricing</b> screen by:</p> <ol style="list-style-type: none"> <li>1. Search for a price item in the <b>Search Price Item or Price Item Pricing</b> zone.</li> <li>2. In the <b>Search Results</b> section, click the <b>Assign</b> () icon corresponding to the price item.</li> <li>3. Enter the required details in the <b>Price Item Pricing</b> screen and click <b>Save</b>.</li> <li>4. The <b>Price Item Pricing</b> screen appears.</li> </ol> </div>
Price components of Price Item Pricing assigned to a person	<ol style="list-style-type: none"> <li>1. Search for the person in the <b>Customer 360° View</b> screen.</li> <li>2. In the <b>Search Results</b> section, click the <b>Show Context Menu</b> (☰) icon corresponding to the person whose <i>details</i> you want to view. A menu appears.</li> <li>3. Click the <b>Go To Effective Pricing</b> menu option. The <b>Pricing (Person)</b> screen appears.</li> </ol>

If you want to delete pricing eligibility criteria of...	Then...
	<p>4. Price assignments effective for the person appears in the <b>Effective Price Assignments for Person</b> zone.</p> <p>5. In the <b>Search Results</b> section, click the link in the <b>Pricing Information</b> column corresponding to the price item whose pricing details you want to view.</p> <p>The <b>Price Item Pricing</b> screen appears.</p> <div style="border: 1px solid black; padding: 5px; margin-top: 10px;"> <p><b>Tip:</b> Alternatively, you can access the <b>Price Item Pricing</b> screen by:</p> <ol style="list-style-type: none"> <li>1. Search for a price item in the <b>Search Price Item or Price Item Pricing</b> zone.</li> <li>2. In the <b>Search Results</b> section, click the <b>Assign</b> () icon corresponding to the price item.</li> <li>3. Enter the required details in the <b>Price Item Pricing</b> screen and click <b>Save</b>.</li> <li>4. The <b>Price Item Pricing</b> screen appears.</li> </ol> </div>
Price components of Price Item Pricing assigned to a price list	<ol style="list-style-type: none"> <li>1. Search for the price list in the <b>Price List</b> screen.</li> <li>2. In the <b>Search Results</b> section, click the <b>Price List Pricing</b> () icon corresponding to the price list whose details you want to view.</li> </ol> <p>The <b>Price List Price Item Pricing</b> screen appears.</p> <ol style="list-style-type: none"> <li>3. Price items assigned to the price list appears in the <b>Price List Price Items</b> zone.</li> <li>4. In the <b>Search Results</b> section, click the link in the <b>Pricing Information</b> column corresponding to the price item whose pricing details you want to view.</li> </ol> <p>The <b>Price Item Pricing</b> screen appears.</p>

If you want to delete pricing eligibility criteria of...	Then...
	<p><b>Tip:</b> Alternatively, you can access the <b>Price Item Pricing</b> screen by:</p> <ol style="list-style-type: none"> <li>1. Search for a price item in the <b>Search Price Item or Price Item Pricing</b> zone.</li> <li>2. In the <b>Search Results</b> section, click the <b>Assign</b> () icon corresponding to the price item.</li> <li>3. Enter the required details in the <b>Price Item Pricing</b> screen and click <b>Save</b>.</li> <li>4. The <b>Price Item Pricing</b> screen appears.</li> </ol>

2. In the **Rate Components** zone, click the **Broadcast** () icon corresponding to the rate component, the **Price Components** zone appears with the details of the price components for the respective rate component.
3. In the **Price Components** zone, click the **Broadcast** () icon corresponding to the price component, the **Pricing Eligibility Criteria** zone appears with the details of parameters used in the pricing eligibility criteria.

**Note:**

The **Pricing Eligibility Criteria** zone appears only when eligibility checkbox is selected in the **Price Item Pricing** screen and details for pricing eligibility criteria is added in the **Price Component** screen.

4. Click the **Delete** () icon in the **Delete** column corresponding to the pricing eligibility criteria that you want to remove for the price component.

**Note:** The **Delete** icon appears only when the price assignment is in **Draft**, **Proposed** or **Template** status.

A message appears confirming whether you want to remove the pricing eligibility criteria of a price component.

5. Click **OK**.

The pricing eligibility criteria is removed for the price component.

**Related Topics**

For more information on...	See...
<b>360-Degree Search</b> zone	<a href="#">360° Search</a>
How to search for a person.	<a href="#">Searching for a Person</a>
How to search for an account.	<a href="#">Searching for an Account</a>
<b>Search Price List</b> zone	<a href="#">Search Price List</a> on page 367
How to search for a price list.	<a href="#">Searching for a Price List</a> on page 371
<b>Rate Components</b> zone	<a href="#">Rate Components</a> on page 512
<b>Price Components</b> zone	<a href="#">Price Components</a> on page 512
<b>Pricing Eligibility Criteria</b> zone	<a href="#">Pricing Eligibility Criteria</a> on page 514



For more information on...	See...
How to view pricing eligibility criteria of a price component.	<a href="#">Viewing the Pricing Eligibility Criteria of a Price Component</a> on page 522
How to define a pricing eligibility criteria for a price component.	<a href="#">Defining a Pricing Eligibility Criteria for a Price Component</a> on page 530



## Deleting a Price Item Pricing

### Procedure

To delete a price item pricing:

1. Do either of the following:

If you want to delete...	Then...
Price Item Pricing assigned to an account	<ol style="list-style-type: none"> <li>1. Search for the account in the <b>Customer 360° View</b> screen.</li> <li>2. In the <b>Search Results</b> section, click the <b>Show Context Menu</b> () icon corresponding to the account whose <i>details</i> you want to view. A menu appears.</li> <li>3. Click the <b>Go To Effective Pricing</b> menu option. The <b>Pricing (Account)</b> screen appears.</li> <li>4. Price assignments effective for the account appears in the <b>Effective Price Assignments for Account</b> zone.</li> <li>5. In the <b>Search Results</b> section, click the link in the <b>Pricing Information</b> column corresponding to the price item whose pricing details you want to view. The <b>Price Item Pricing</b> screen appears.</li> </ol> <div style="border: 1px solid black; padding: 5px; margin-top: 10px;"> <p><b>Tip:</b> Alternatively, you can access the <b>Price Item Pricing</b> screen by:</p> <ol style="list-style-type: none"> <li>1. Search for a price item in the <b>Search Price Item or Price Item Pricing</b> zone.</li> <li>2. In the <b>Search Results</b> section, click the <b>Assign</b> () icon corresponding to the price item.</li> <li>3. Enter the required details in the <b>Price Item Pricing</b> screen and click <b>Save</b>.</li> <li>4. The <b>Price Item Pricing</b> screen appears.</li> </ol> </div>
Price Item Pricing assigned to a person	<ol style="list-style-type: none"> <li>1. Search for the person in the <b>Customer 360° View</b> screen.</li> </ol>

If you want to delete...	Then...
	<ol style="list-style-type: none"> <li>2. In the <b>Search Results</b> section, click the <b>Show Context Menu</b> () icon corresponding to the person whose <i>details</i> you want to view. A menu appears.</li> <li>3. Click the <b>Go To Effective Pricing</b> menu option. The <b>Pricing (Person)</b> screen appears.</li> <li>4. Price assignments effective for the person appears in the <b>Effective Price Assignments for Person</b> zone.</li> <li>5. In the <b>Search Results</b> section, click the link in the <b>Pricing Information</b> column corresponding to the price item whose pricing details you want to view. The <b>Price Item Pricing</b> screen appears.</li> </ol> <div style="border: 1px solid black; padding: 5px; margin-top: 10px;"> <p><b>Tip:</b> Alternatively, you can access the <b>Price Item Pricing</b> screen by:</p> <ol style="list-style-type: none"> <li>1. Search for a price item in the <b>Search Price Item or Price Item Pricing</b> zone.</li> <li>2. In the <b>Search Results</b> section, click the <b>Assign</b> () icon corresponding to the price item.</li> <li>3. Enter the required details in the <b>Price Item Pricing</b> screen and click <b>Save</b>.</li> <li>4. The <b>Price Item Pricing</b> screen appears.</li> </ol> </div>
Price Item Pricing assigned to a price list	<ol style="list-style-type: none"> <li>1. Search for the price list in the <b>Price List</b> screen.</li> <li>2. In the <b>Search Results</b> section, click the <b>Price List Pricing</b> () icon corresponding to the price list whose <i>details</i> you want to view. The <b>Price List Price Item Pricing</b> screen appears.</li> <li>3. Price items assigned to the price list appears in the <b>Price List Price Items</b> zone.</li> <li>4. In the <b>Search Results</b> section, click the link in the <b>Pricing Information</b> column corresponding to the price item whose pricing details you want to view. The <b>Price Item Pricing</b> screen appears.</li> </ol>

If you want to delete...	Then...
	<p><b>Tip:</b> Alternatively, you can access the <b>Price Item Pricing</b> screen by:</p> <ol style="list-style-type: none"> <li>1. Search for a price item in the <b>Search Price Item or Price Item Pricing</b> zone.</li> <li>2. In the <b>Search Results</b> section, click the <b>Assign</b> () icon corresponding to the price item.</li> <li>3. Enter the required details in the <b>Price Item Pricing</b> screen and click <b>Save</b>.</li> <li>4. The <b>Price Item Pricing</b> screen appears.</li> </ol>

2. Click the **Delete** button in the **Record Actions** zone.

**Note:**

When the price assignment is in **Draft** status then the **Delete** button appears.

When the price assignment is in **Draft** status and when the approval workflow is on and:

- If the approval workflow is in **Draft** status then it is changed to **Pending in Approval**.
- If the approval workflow is in **Proposed** status and,
  - If the price assignment is not approved for the first time then **Delete** button appears.
  - If the price assignment is approved then **Delete** button does not appear.
- When the approval workflow is in **Template** status and,
  - If the price assignment is not approved for the first time then **Delete** button appears.
  - If the price assignment is approved then **Delete** button does not appear.

When the price assignment is in **Draft** status, and when the approval workflow is off and is in **Draft** status then it is changed to **Active**.

A message appears confirming whether you want to delete the price item pricing.

3. Click **OK**.

The price item pricing is deleted.

**Related Topics**

For more information on...	See...
<b>360-Degree Search</b> zone	<a href="#">360° Search</a>
How to search for a person.	<a href="#">Searching for a Person</a>
How to search for an account.	<a href="#">Searching for an Account</a>
<b>Search Price List</b> zone	<a href="#">Search Price List</a> on page 367
How to search for a price list.	<a href="#">Searching for a Price List</a> on page 371
How to view a price item pricing	<a href="#">Price Item Pricing (Used for Viewing)</a> on page 507
<b>Price Item Pricing</b> zone	<a href="#">Price Item Pricing</a> on page 508



## Editing a Price Item Pricing

### Prerequisites

To edit a price item pricing, you should have:

- Transactions mapped to the price item defined in the application
- Rate schedules, rate versions, rate components defined in the application
- Tiering criteria defined in the application
- Tiering setup for the rate components defined in the application
- Pricing eligibility defined in the application
- Parameters associated with the price item (in case you want to define price item pricing based on those parameters)



### Procedure

To edit a price item pricing:



1. Do either of the following:

If you want to...	Then...
Edit pricing of a price item that is assigned to a person	<ol style="list-style-type: none"> <li>1. Search for the person in the <b>Customer 360° View</b> screen.</li> <li>2. In the <b>Search Results</b> section, click the <b>Show Context Menu</b> (☰) icon corresponding to the person whose <i>details</i> you want to view. A menu appears.</li> <li>3. Click the <b>Go To Effective Pricing</b> menu option. The <b>Pricing (Person)</b> screen appears.</li> <li>4. Price assignments effective for the person appears in the <b>Effective Price Assignments for Person</b> zone.</li> <li>5. You can edit the pricing item pricing through the following alternatives:               <ol style="list-style-type: none"> <li>a. First alternative,                   <ul style="list-style-type: none"> <li>• In the <b>Search Results</b> section of <b>Effective Price Assignments for Person</b> zone, click the <b>Edit</b> (✎) icon in the <b>Edit</b> column corresponding to the price item pricing whose details you want to edit. The <b>Price Item Pricing</b> screen appears to edit the pricing details of a price item.</li> </ul> </li> <li>b. Second alternative,</li> </ol> </li> </ol>



If you want to...	Then...
	<ul style="list-style-type: none"> <li>• In the <b>Search Results</b> section of <b>Effective Price Assignments for Person</b> zone, click the link in the <b>Pricing Information</b> column corresponding to the price item whose pricing details you want to view.  The <b>Price Item Pricing</b> screen appears.</li> <li>• Click the <b>Edit</b> button in the <b>Record Actions</b> section.  The <b>Price Item Pricing</b> screen appears to edit the pricing details of a price item.</li> </ul> <div data-bbox="1013 716 1395 827" style="border: 1px solid black; padding: 5px; margin: 10px 0;"> <p><b>Note:</b> The <b>Edit</b> button appears only when the price item pricing is in the <b>Draft</b> status.</p> </div> <p>c. Third alternative,</p> <ul style="list-style-type: none"> <li>• Search for a price item in the <b>Search Price Item or Price Item Pricing</b> zone.  In the <b>Search Results</b> section, click the <b>Assign</b> () icon corresponding to the price item.</li> <li>• Enter the required details in the <b>Price Item Pricing</b> screen and click <b>Save</b>.  The <b>Price Item Pricing</b> screen appears.</li> <li>• Click the <b>Edit</b> button in the <b>Record Actions</b> section.  The <b>Price Item Pricing</b> screen appears to edit the pricing details of a price item.</li> </ul> <div data-bbox="1013 1535 1395 1646" style="border: 1px solid black; padding: 5px; margin: 10px 0;"> <p><b>Note:</b> The <b>Edit</b> button appears only when the price item pricing is in the <b>Draft</b> status.</p> </div>
Edit pricing of a price item that is assigned to an account	<ol style="list-style-type: none"> <li>1. Search for the person in the <b>Customer 360° View</b> screen.</li> <li>2. In the <b>Search Results</b> section, click the <b>Show Context Menu</b> () icon corresponding to the account whose <i>details</i> you want to view.</li> </ol>

If you want to...	Then...
	<p>A menu appears.</p> <ol style="list-style-type: none"> <li>3. Click the <b>Go To Effective Pricing</b> menu option. The <b>Pricing (Account)</b> screen appears.</li> <li>4. Price assignments effective for the account appears in the <b>Effective Price Assignments for Account</b> zone.</li> <li>5. You can edit the pricing item pricing through the following alternatives:               <ol style="list-style-type: none"> <li>a. First alternative,                   <ul style="list-style-type: none"> <li>• In the <b>Search Results</b> section of <b>Effective Price Assignments for Account</b> zone, click the <b>Edit</b> (✎) icon in the <b>Edit</b> column corresponding to the price item pricing whose details you want to edit.  The <b>Price Item Pricing</b> screen appears to edit the pricing details of a price item.</li> </ul> </li> <li>b. Second alternative,                   <ul style="list-style-type: none"> <li>• In the <b>Search Results</b> section of <b>Effective Price Assignments for Account</b> zone, click the link in the <b>Pricing Information</b> column corresponding to the price item whose pricing details you want to view.  The <b>Price Item Pricing</b> screen appears.</li> <li>• Click the <b>Edit</b> button in the <b>Record Actions</b> section.  The <b>Price Item Pricing</b> screen appears to edit the pricing details of a price item.</li> </ul> </li> </ol> <div style="border: 1px solid black; padding: 5px; margin: 10px 0;"> <p><b>Note:</b> The <b>Edit</b> button appears only when the price item pricing is in the <b>Draft</b> status.</p> </div> </li> <li>c. Third alternative,                   <ul style="list-style-type: none"> <li>• Search for a price item in the <b>Search Price Item or Price Item Pricing</b> zone.</li> </ul> </li> </ol>

If you want to...	Then...
	<p>In the <b>Search Results</b> section, click the <b>Assign</b> () icon corresponding to the price item.</p> <ul style="list-style-type: none"> <li>Enter the required details in the <b>Price Item Pricing</b> screen and click <b>Save</b>.</li> </ul> <p>The <b>Price Item Pricing</b> screen appears.</p> <ul style="list-style-type: none"> <li>Click the <b>Edit</b> button in the <b>Record Actions</b> section.</li> </ul> <p>The <b>Price Item Pricing</b> screen appears to edit the pricing details of a price item.</p> <div data-bbox="1013 722 1398 835" style="border: 1px solid black; padding: 5px;"> <p><b>Note:</b> The <b>Edit</b> button appears only when the price item pricing is in the <b>Draft</b> status.</p> </div>
<p>Edit pricing of a price item that is assigned to a price list</p>	<ol style="list-style-type: none"> <li>Search for the price list in the <b>Price List</b> screen.</li> <li>In the <b>Search Results</b> section, click the <b>Price List Pricing</b> () icon corresponding to the price list whose <i>details</i> you want to view. <p>The <b>Price List Price Item Pricing</b> screen appears.</p> </li> <li>Price items assigned to the price list appears in the <b>Price List Price Items</b> zone.</li> <li>You can edit the pricing item pricing through the following alternatives: <ol style="list-style-type: none"> <li>First alternative, <ul style="list-style-type: none"> <li>In the <b>Search Results</b> section of <b>Price List Price Items</b> zone, click the <b>Edit</b> () icon in the <b>Edit</b> column corresponding to the price item pricing whose details you want to edit. <p>The <b>Price Item Pricing</b> screen appears to edit the pricing details of a price item.</p> </li> </ul> </li> <li>Second alternative, <ul style="list-style-type: none"> <li>In the <b>Search Results</b> section of <b>Price List Price Items</b> zone, click the link in the <b>Pricing Information</b> column corresponding to the price</li> </ul> </li> </ol> </li> </ol>

If you want to...	Then...
	<p>item whose pricing details you want to view.</p> <p>The <b>Price Item Pricing</b> screen appears.</p> <ul style="list-style-type: none"> <li>Click the <b>Edit</b> button in the <b>Record Actions</b> section.</li> </ul> <p>The <b>Price Item Pricing</b> screen appears to edit the pricing details of a price item.</p> <div data-bbox="1013 554 1399 667" style="border: 1px solid black; padding: 5px;"> <p><b>Note:</b> The <b>Edit</b> button appears only when the price item pricing is in the <b>Draft</b> status.</p> </div> <p>c. Third alternative,</p> <ul style="list-style-type: none"> <li>Search for a price item in the <b>Search Price Item or Price Item Pricing</b> zone.</li> </ul> <p>In the <b>Search Results</b> section, click the <b>Assign</b> () icon corresponding to the price item.</p> <ul style="list-style-type: none"> <li>Enter the required details in the <b>Price Item Pricing</b> screen and click <b>Save</b>.</li> </ul> <p>The <b>Price Item Pricing</b> screen appears.</p> <ul style="list-style-type: none"> <li>Click the <b>Edit</b> button in the <b>Record Actions</b> section.</li> </ul> <p>The <b>Price Item Pricing</b> screen appears to edit the pricing details of a price item.</p> <div data-bbox="1013 1373 1399 1486" style="border: 1px solid black; padding: 5px;"> <p><b>Note:</b> The <b>Edit</b> button appears only when the price item pricing is in the <b>Draft</b> status.</p> </div>

The **Price Item Pricing** screen appears.

2. Modify the required pricing details.

**Note:**

If you change the effective start and end dates while editing a price item pricing, you need to specify the parameters which are effective during that date range.

You can search for parameter, rate schedule by clicking the **Search** () icon corresponding to the respective fields.

3. Edit the TFM Information in a price item pricing, if required.

4. Edit the characteristics for a price item pricing, if required.
5. Edit the parameters for a price item pricing, if required.
6. Edit the price assignment, if required.
7. Click **Save**.

**Note:**

If any value other than **Status** and **End Date** is updated then the price item pricing for the price item is end with **End Date** updated as (today's date -1) and a new price item pricing is generated for the price item with new price item pricing ID and start date as today's date.

The **Edit Price Components** button appears only when you are editing a price assignment which is in the **Active**, **Proposed**, or **Template** status and which is not past dated; If the approval workflow is on, then the **Edit Price Components** button appears when you are editing a proposed and template price assignment which is already approved.

When the price assignment is in **Draft** status and,

- When the approval workflow is on and is in **Draft** status then it is changed to **Pending in Approval**.

When the price assignment is in **Draft** status and,

- When the approval workflow is off and is in **Draft** status then it is changed to **Active**.

The changes made to the price item pricing are saved.

**Related Topics**

<b>For more information on...</b>	<b>See...</b>
<b>360° Search</b> zone	<a href="#">360° Search</a>
How to search for a person.	<a href="#">Searching for a Person</a>
<b>Pricing (Person)</b> screen	<a href="#">Pricing (Person)</a> on page 473
<b>Effective Price Assignments for Person</b> zone	<a href="#">Effective Price Assignments for Person</a> on page 474
How to search for an account.	<a href="#">Searching for an Account</a>
<b>Pricing (Account)</b> screen	<a href="#">Pricing (Account)</a> on page 439
<b>Effective Price Assignments for Account</b> zone	<a href="#">Effective Price Assignments for Account</a> on page 440
<b>Search Price List</b> zone	<a href="#">Search Price List</a> on page 367
How to search for a price list.	<a href="#">Searching for a Price List</a> on page 371
<b>Price List Price Item Pricing</b> screen	<a href="#">Price List Price Item Pricing</a> on page 387
<b>Price List Price Items</b> zone	<a href="#">Price List Price Items</a> on page 388
<b>Price Item Pricing</b> screen	<a href="#">Price Item Pricing (Used for Viewing)</a> on page 507
How to define a price item pricing for an account.	<a href="#">Assigning a Price Item to an Account</a> on page 466
How to define a price item pricing for a person.	<a href="#">Assigning a Price Item to a Person</a> on page 500
How to define a price item pricing for a price list.	<a href="#">Assigning a Price Item to a Price List</a> on page 401
How to define characteristics for a price item pricing.	<a href="#">Defining Characteristics for a Price Item Pricing</a> on page 405
How to define parameters for a price item pricing.	<a href="#">Defining Parameters for a Price Item Pricing</a> on page 406



For more information on...	See...
How to define TFM Information in a price item pricing.	<a href="#">Defining TFM Information in a Price Item Pricing</a> on page 407



## Submitting a Price Item Pricing

### Procedure

To submit pricing for a price item:

1. Do either of the following:

If you want to...	Then...
Submit pricing of a price item that is assigned to a person	<ol style="list-style-type: none"> <li>1. Search for the person in the <b>Customer 360° View</b> screen.</li> <li>2. In the <b>Search Results</b> section, click the <b>Show Context Menu</b> () icon corresponding to the person whose <i>details</i> you want to view. A menu appears.</li> <li>3. Click the <b>Go To Effective Pricing</b> menu option. The <b>Pricing (Person)</b> screen appears.</li> <li>4. Price assignments effective for the person appears in the <b>Effective Price Assignments for Person</b> zone.</li> <li>5. In the <b>Search Results</b> section, click the link in the <b>Pricing Information</b> column corresponding to the price item whose pricing details you want to view. The <b>Price Item Pricing</b> screen appears.</li> </ol> <div style="border: 1px solid black; padding: 5px; margin-top: 10px;"> <p><b>Tip:</b> Alternatively, you can access the <b>Price Item Pricing</b> screen by:</p> <ol style="list-style-type: none"> <li>1. Search for a price item in the <b>Search Price Item or Price Item Pricing</b> zone.</li> <li>2. In the <b>Search Results</b> section, click the <b>Assign</b> () icon corresponding to the price item.</li> <li>3. Enter the required details in the <b>Price Item Pricing</b> screen and click <b>Save</b>.</li> <li>4. The <b>Price Item Pricing</b> screen appears.</li> </ol> </div>
Submit pricing of a price item that is assigned to an account	<ol style="list-style-type: none"> <li>1. Search for the person in the <b>Customer 360° View</b> screen.</li> </ol>

If you want to...	Then...
	<p>2. In the <b>Search Results</b> section, click the <b>Show Context Menu</b> () icon corresponding to the person whose <i>details</i> you want to view.</p> <p>A menu appears.</p> <p>3. Click the <b>Go To Effective Pricing</b> menu option.</p> <p>The <b>Pricing (Account)</b> screen appears.</p> <p>4. Price assignments effective for the person appears in the <b>Effective Price Assignments for Account</b> zone.</p> <p>5. In the <b>Search Results</b> section, click the link in the <b>Pricing Information</b> column corresponding to the price item whose pricing details you want to view.</p> <p>The <b>Price Item Pricing</b> screen appears.</p> <div style="border: 1px solid black; padding: 5px; margin-top: 10px;"> <p><b>Tip:</b> Alternatively, you can access the <b>Price Item Pricing</b> screen by:</p> <ol style="list-style-type: none"> <li>1. Search for a price item in the <b>Search Price Item or Price Item Pricing</b> zone.</li> <li>2. In the <b>Search Results</b> section, click the <b>Assign</b> () icon corresponding to the price item.</li> <li>3. Enter the required details in the <b>Price Item Pricing</b> screen and click <b>Save</b>.</li> <li>4. The <b>Price Item Pricing</b> screen appears.</li> </ol> </div>
Submit pricing of a price item that is assigned to a pricelist	<ol style="list-style-type: none"> <li>1. Search for the price list in the <b>Price List</b> screen.</li> <li>2. In the <b>Search Results</b> section, click the <b>Price List Pricing</b> () icon corresponding to the price list whose <i>details</i> you want to view.</li> <p>The <b>Price List Price Item Pricing</b> screen appears.</p> <li>3. Price items assigned to the price list appears in the <b>Price List Price Items</b> zone.</li> <li>4. In the <b>Search Results</b> section of <b>Price List Price Items</b> zone, click the link in the <b>Pricing Information</b> column corresponding to the price item whose pricing details you want to view.</li> <p>The <b>Price Item Pricing</b> screen appears.</p> </ol>

If you want to...	Then...
	<p><b>Tip:</b> Alternatively, you can access the <b>Price Item Pricing</b> screen by:</p> <ol style="list-style-type: none"> <li>1. Search for a price item in the <b>Search Price Item or Price Item Pricing</b> zone.</li> <li>2. In the <b>Search Results</b> section, click the <b>Assign</b> () icon corresponding to the price item.</li> <li>3. Enter the required details in the <b>Price Item Pricing</b> screen and click <b>Save</b>.</li> <li>4. The <b>Price Item Pricing</b> screen appears.</li> </ol>

2. Click the **Submit** button in the **Record Actions** section.

<b>Note:</b>
<p>When the price assignment is in <b>Draft</b> status and when the approval workflow is on and:</p> <ul style="list-style-type: none"> <li>• When the approval workflow is in <b>Draft</b> status then it is changed to <b>Pending in Approval</b>.</li> <li>• When the approval workflow is in <b>Proposed</b> status and on clicking the <b>Submit</b> button, the status does not change and remains the same.</li> <li>• When the approval workflow is in <b>Template</b> status and on clicking the <b>Submit</b> button, the status does not change and remains the same.</li> </ul> <p>When the price assignment is in <b>Draft</b> status and when the approval workflow is off and:</p> <ul style="list-style-type: none"> <li>• When the approval workflow is in <b>Draft</b> status then it is changed to <b>Active</b>.</li> <li>• When the approval workflow is in <b>Proposed</b> status then on clicking the <b>Submit</b> button, the status does not change and remains the same.</li> <li>• When the approval workflow is in <b>Template</b> status then on clicking the <b>Submit</b> button, the status does not change and remains the same.</li> </ul>

### **Related Topics**

For more information on...	See...
<b>360° Search</b> zone	<a href="#">360° Search</a>
How to search for a person.	<a href="#">Searching for a Person</a>
<b>Pricing (Person)</b> screen	<a href="#">Pricing (Person)</a> on page 473
<b>Effective Price Assignments for Person</b> zone	<a href="#">Effective Price Assignments for Person</a> on page 474
How to search for an account.	<a href="#">Searching for an Account</a>
<b>Pricing (Account)</b> screen	<a href="#">Pricing (Account)</a> on page 439
<b>Effective Price Assignments for Account</b> zone	<a href="#">Effective Price Assignments for Account</a> on page 440
<b>Search Price List</b> zone	<a href="#">Search Price List</a> on page 367
How to search for a price list.	<a href="#">Searching for a Price List</a> on page 371



For more information on...	See...
Price List Price Item Pricing screen	<a href="#">Price List Price Item Pricing</a> on page 387
Price List Price Items zone	<a href="#">Price List Price Items</a> on page 388
Price Item Pricing screen	<a href="#">Price Item Pricing (Used for Viewing)</a> on page 507

## Overriding a Price Item Pricing

### Prerequisites



To override a price item pricing, you should have:

- Transactions mapped to the price item defined in the application
- Rate schedules, rate versions, rate components defined in the application
- Tiering criteria defined in the application
- Tiering setup for the rate components defined in the application
- Pricing eligibility defined in the application
- Parameters associated with the price item (in case you want to define price item pricing based on multiple parameters)

### Procedure

To override a price item pricing:

1. Do either of the following:

If you want to...	Then...
Override price item pricing assigned to the customer either directly or through the customer hierarchy or price list	<ol style="list-style-type: none"> <li>1. Access the <b>Pricing (Person)</b> screen.</li> <li>2. In the <b>Effective Price Assignment</b> zone, click the <b>Override</b>  icon in the <b>Override</b> column corresponding to the price item pricing that you want to override.</li> </ol>
Override price item pricing assigned to the account either directly or through the customer hierarchy or price list	<ol style="list-style-type: none"> <li>1. Access the <b>Pricing (Account)</b> screen.</li> <li>2. In the <b>Effective Price Assignment</b> zone, click the <b>Override</b>  icon in the <b>Override</b> column corresponding to the price item pricing that you want to override.</li> </ol>

The **Price Item Pricing** screen appears.

2. Modify the required pricing details.

#### Note:

If you change the effective start and end dates while overriding a price item pricing, you need to specify the parameters which are effective during that date range.

While overriding a price item pricing, you can not only edit the existing tiering combination details, but also add additional tiering combinations until the maximum tiering combinations limit is met.

3. Modify the price assignment characteristics, if required.
4. Click **Save**.

The price item pricing is overridden.

### Related Topics

For more information on...	See...
Price Item Pricing screen	<a href="#">Price Item Pricing</a>
How to edit the characteristics of the price assignment	<a href="#">Editing the Price Assignment Characteristics</a>

## Editing the Two-Dimensional Pricing

### Procedure

To edit a two-dimensional pricing:

1. Search for the account in the **Customer 360° View** screen.
2. In the **Search Results** section, click the **Show Context Menu** () icon corresponding to the account whose details you want to view.

A menu appears.

3. Click the **Go To Effective Pricing** menu option.

The **Pricing (Person)** screen appears.

4. Search for the price item pricing in the **Search Price Item or Price Item Pricing** screen.

5. Click the **Assign** icon () corresponding to the **Price Item Information**.

The **Price Item Pricing** screen appears. It contains the following fields:

Field Name	Field Description	Mandatory (Yes or No)
Start Date	Displays the date from when the price item pricing is effective.	Yes
End Date	Displays the date till when the price item pricing is effective.	No
Rate Schedule	Indicates the rate schedule used while defining price item pricing.  <b>Note:</b> It has a link. On clicking the link, the <b>Rate Schedule</b> screen appears where you can view the details of the rate schedule.	Yes
Print Zero	Indicates the zero pricing displayed in the bill. The valid values are: <ul style="list-style-type: none"> <li>• Yes</li> <li>• No</li> </ul>	Yes
Pricing Currency	Indicates the currency in which the price item pricing is defined.  <b>Note:</b> It has a link. On clicking the link, the <b>Currency</b> screen appears where you can view the details of the currency.	Yes

Field Name	Field Description	Mandatory (Yes or No)
Pricing Status	Indicates the status of the price assignment. The valid values are: <ul style="list-style-type: none"> <li>• Draft</li> <li>• Active</li> <li>• Inactive</li> <li>• Proposed</li> <li>• Rejected</li> <li>• Template</li> </ul>	Yes
Price Assignment Type	Indicates the type of price assignment. The valid values are: <ul style="list-style-type: none"> <li>• Regular</li> <li>• Post Processing</li> <li>• Post Processing – Invoice Based</li> <li>• Post Processing – Price Item Based</li> </ul>	Yes
Pricing Eligibility	Displays the pricing eligibility criteria for price item pricing.	Yes
Pricing Rule Type	Indicates the pricing rule type. The valid value is: <ul style="list-style-type: none"> <li>• Two-Dimensional</li> </ul>	Yes

6. Click **Save**.

The **Price Item Pricing** screen appears.

7. Click the **Edit** link in the top-right of the **Two-Dimensional Pricing** zone.

The **Two-Dimensional Pricing** screen appears. It contains the following fields in a grid:

Field Name	Field Description
Step Criterion	Used to search by the various criterion.
Threshold Parameter	Used to search by the threshold parameter.
Tiering Range	Displays the tiering range of the pricing.

8. Modify the details in the **Two-Dimensional Pricing** screen, if required.

9. If you want to add more than one threshold parameter, click the **Add** (+) icon and then enter the threshold parameter name and its value.

However, if you want to remove a threshold parameter, click the **Delete** (trash) icon corresponding to the parameter.

10. If you want to add more than one tiering range, click the **Add** (+) icon and then enter the specific range.

However, if you want to remove a tiering range, click the **Delete** (trash) icon corresponding to the range that you want to remove.

11. Click **Save**.

The changes made to the two-dimensional pricing are saved.

**Related Topics**

For more information on...	See...
How to search for a price list	<a href="#">Searching for a Price List</a> on page 371

## Pricing Simulation

The **Pricing Simulation** screen allows you to:

- View pricing simulation details for account or price list
- View effective pricing information
- Search simulation details of account or price list

This screen consists of the following zones:

- [Search Pricing](#) on page 572

Through the **Pricing Simulation** screen, you can navigate to the following screens:

- [Price Item \(Used for Viewing\)](#) on page 339
- [Simulation - Effective Pricing Information](#) on page 576

## Search Pricing

The **Search Pricing** zone allows you to search pricing for an account.



In case of bundles, the order in which the price item pricing is listed in this zone is based on the following condition:



- If the system finds pricing for price items that belong to a bundle before finding pricing for the bundle, then the system lists the pricing for price items that belong to the bundle, and not the pricing for the bundle. For example, let say, B0001 is a bundle, and contains C0001 and C0002 price items. If the system finds pricing for B0001, it validates whether the pricing for C0001 and C0002 has already been found. If yes, then the system lists the pricing for C0001 and C0002. If the system does not find pricing for C0001 and C0002 before finding pricing for B0001, it lists the pricing for B0001.

**Note:** If the effective pricing is available for the price item, regular bundle (to which the price item belongs), and parent (regular) bundle (i.e. to which the regular bundle belongs) at the same level, the system lists the pricing depending on the value defined for the **Prefer Price Item Over Bundle** parameter in the price assignment search algorithm. If the value of the **Prefer Price Item Over Bundle** parameter is set to **Y**, the system lists effective pricing which is available for the price item. If the effective pricing is not available for the price item, then the system lists effective pricing which is available for the regular bundle at the same level. If the effective pricing is not available for the regular bundle, then the system lists effective pricing which is available for the parent bundle at the same level. However, if the value of the **Prefer Price Item Over Bundle** parameter is set to **N**, the system lists effective pricing which is available for the parent bundle. If the effective pricing is not available for the parent bundle, then the system lists effective pricing which is available for the regular bundle at the same level. If the effective pricing is not available for the regular bundle, then the system lists effective pricing which is available for the price item at the same level.

This zone contains the following two sections:

- **Search Criteria** — The **Search Criteria** section contains the following two options:

Field Name	Field Description	Mandatory (Yes or No)
Search By	Used to indicate whether you want to search for pricing using price list or account or person details. The valid values are: <ul style="list-style-type: none"> <li>• Price List</li> <li>• Account /Person</li> </ul> <div style="border: 1px solid black; padding: 2px; margin-top: 5px;"><b>Note:</b> By default, <b>Price List</b> option is selected.</div>	Yes
Price List ID	Used to indicate Price List ID for which simulation must be created. <div style="border: 1px solid black; padding: 2px; margin-top: 5px;"><b>Note:</b> This field appears only when the <b>Price List ID</b> option is selected for the <b>Search By</b> field. The <b>Search</b>  icon appears corresponding to this field. On clicking the <b>Search</b> icon, the <b>Price List Search</b> screen appears.</div>	Yes
Account ID	Used to specify the account for which simulation must be created. <div style="border: 1px solid black; padding: 2px; margin-top: 5px;"><b>Note:</b> This field appears only when the <b>Account</b> option is selected for the <b>Search By</b> field. The <b>Search</b>  icon appears corresponding to this field. On clicking the <b>Search</b> icon, the <b>Account Search</b> screen appears.</div>	Yes
Person ID	Used to specify the person for which simulation must be created. This field gets auto populated once the Account ID value is defined. <div style="border: 1px solid black; padding: 2px; margin-top: 5px;"><b>Note:</b> The <b>Search</b>  icon appears corresponding to this field. On clicking the <b>Search</b> icon, the <b>Person Search</b> screen appears.</div>	Yes
Simulation Date	Used to search price simulations which are effective from a particular date onwards.	Yes
Pricing Status	Used to search price assignments with a particular status. The valid values are: <ul style="list-style-type: none"> <li>• Active</li> <li>• Proposed</li> </ul>	No

Field Name	Field Description	Mandatory (Yes or No)
Search Type	Used to indicate whether you want to search the price list using the following values: <ul style="list-style-type: none"> <li>• Best Fit</li> <li>• Exact Match</li> </ul> <div style="border: 1px solid black; padding: 2px;"> <p><b>Note:</b> By default, <b>Exact Match</b> option is selected.</p> </div>	No
Show Default and Global Pricing	Used to indicate whether the product is assigned to a default and global price list. The valid values are: <ul style="list-style-type: none"> <li>• Yes</li> <li>• No</li> </ul>	No
Price Item	Used to specify the price items for pricing simulation. <div style="border: 1px solid black; padding: 2px;"> <p><b>Note:</b> The <b>Search</b>  icon appears corresponding to this field. On clicking the <b>Search</b> icon, the <b>Price Item Search</b> screen appears.</p> </div>	No
Description	Used to search price assignments of a price item having a particular description.	No
View Type	Used to indicate whether you want to view summary or tiering details of price components. The valid values are: <ul style="list-style-type: none"> <li>• <b>Detail</b> — Used when you want to view the details of price component with pricing eligibility and tiering criteria.</li> <li>• <b>Summary</b> — Used when you want to view the summary of effective price component.</li> </ul>	No
Parameter	Used to specify multiple parameter codes based on which you want to define the pricing. <div style="border: 1px solid black; padding: 2px;"> <p><b>Note:</b> This field appears only when the <b>Multi Price Parameter</b> option type of the <b>Multi Parameter Based Pricing (C1_PPARM_FLG)</b> feature configuration is set to <b>True</b>. The <b>Search</b>  icon appears corresponding to this field. On clicking the <b>Search</b> icon, the <b>Parameter Search</b> screen appears.</p> </div>	No

Field Name	Field Description	Mandatory (Yes or No)
Parameter Value	<p>Displays the value of the parameter or used to specify multiple parameter value.</p> <div style="border: 1px solid black; padding: 5px;"> <p><b>Note:</b></p> <p>The <b>Search</b>  icon appears corresponding to this field only when the value type for the <b>Parameter</b> is <b>Reference</b> or <b>Predefined</b>.</p> <p>If the value type of the <b>Parameter</b> is <b>Reference</b> then on clicking the <b>Search</b> icon, the <b>Reference Parameter Value Search</b> screen appears.</p> <p>If the value type of the <b>Parameter</b> is <b>Predefined</b> then on clicking the <b>Search</b> icon, the <b>Predefined Parameter Value Search</b> screen appears.</p> </div>	No

To add more than one **Parameter**, click the **Add**  icon and to delete the parameters click the **Delete**  icon corresponding to the **Parameter** field.

- **Search Results** — On clicking the **Search** button, the search results appear based on the specified search criteria. The **Search Results** section contains the following columns:

**Note:** If default Price List ID is added to the Price List Value and if **Yes** is selected for **Show Default and Global Pricing**, also if Price List is added to the product for selected account then **Search Results** section will display price list assignments for the value and product will be displayed along with the default price list assignments.

Column Name	Column Description
Price Item	<p>Displays the price item code.</p> <div style="border: 1px solid black; padding: 5px;"> <p><b>Note:</b> It has a link. On clicking the link, the <b>View Price Item</b> screen appears with the details of the respective price item.</p> </div>
Description	Displays the description of the price item.
Variance Parameters	<p>Indicates the variance parameter which is used for defining the price item pricing.</p> <div style="border: 1px solid black; padding: 5px;"> <p><b>Note:</b> This column appears only when the <b>Multi Price Parameter</b> option type of the <b>Multi Parameter Based Pricing (C1_PPARM_FLG)</b> feature configuration is set to <b>False</b>.</p> </div>
Price Item Parameters	<p>Displays a comma-separated list of parameter values. The order in which parameter values appear in this field is controlled by the display order (which is defined while associating a parameter with a price item). A tool tip appears when you hover over this column corresponding to the price item. It indicates the price item parameters and their values used for defining the price item pricing.</p> <div style="border: 1px solid black; padding: 5px;"> <p><b>Note:</b> This column appears only when the <b>Multi Price Parameter</b> option type of the <b>Multi Parameter Based Pricing (C1_PPARM_FLG)</b> feature configuration is set to <b>True</b>.</p> </div>

Column Name	Column Description
Price Assignment Type	Indicates the type of price assignment. The valid values are: <ul style="list-style-type: none"> <li>• Regular</li> <li>• Post Processing</li> <li>• Post Processing — Invoice Based</li> <li>• Post Processing — Price Item Based</li> </ul>
Assignment Level	Indicates the level at which the price item pricing is defined in the customer hierarchy.
Price List Description	Displays the description of the price list. <div style="border: 1px solid black; padding: 5px; margin-top: 5px;"> <b>Note:</b> The description appears only when the pricing assignment type is Account Price List, or Account Inherited Price List. </div>
Rate Description	Displays the description of the tiering setup of the rate component.
Simulate	On clicking the Simulate (🔍) icon, the <b>Simulation — Effective Pricing Information</b> screen appears where you can add the <b>Price Item SQIs</b> and <b>Pricing Eligibility Parameters</b> details that can be passed for pricing simulation. <div style="border: 1px solid black; padding: 5px; margin-top: 5px;"> <b>Note:</b> This column appears only when the price item is <b>Rate</b> and <b>Fees</b>. </div>
Effective Start Date	Displays the date from when the pricing is effective.
Effective End Date	Displays the date till when the pricing is effective.
Pricing Currency	Indicates the currency in which the price item pricing is defined.
Parent Person	Displays the name of the parent or grandparent customer from whom the pricing is inherited.

**Note:**

The number of records that can be displayed in the **Search Results** section of the **Search Pricing** zone is controlled via the **C1\_PR\_REC** feature configuration. You can change the number of records that can be displayed using the **Effective Pricing RecordSet Limit** option type of the **C1\_PR\_REC** feature configuration. For more information, refer to [Setting the C1\\_PR\\_REC Feature Configuration](#) on page 2924.

### Related Topics

For more information on...	See...
How to view effective pricing of a simulation	<a href="#">Simulation - Effective Pricing Information</a> on page 576

## Simulation - Effective Pricing Information

The **Simulation — Effective Pricing Information** screen contains the following sections:



- **SQIs** — This section contains the following fields:



Field Name	Field Description
SQI	<p>Used to indicate the SQI that you want to associate with the price item.</p> <p><b>Note:</b></p> <p>If you want to define more than one price item SQI, click the <b>Add</b> (+) icon corresponding to this field.</p> <p>If you want to remove a price item SQI, click the <b>Delete</b> (🗑️) icon corresponding to this field.</p> <p>The <b>Search</b> (🔍) icon appears corresponding to this field. On clicking the search icon, the <b>Search for Service Quantity Identifier</b> screen appears.</p> <p>This field is required when you want to view the effective pricing simulation.</p>
Value	<p>Used to indicate the SQI value that you want to associate with the price item.</p> <p><b>Note:</b></p> <p>If you want to define more than one value, click the <b>Add</b> (+) icon corresponding to this field.</p> <p>If you want to remove a price item SQI value, click the <b>Delete</b> (🗑️) icon corresponding to this field.</p>

- **Pricing Eligibility Parameters** — This section contains the following fields:

Field Name	Field Description
Parameter	<p>Used to specify multiple parameter codes based on which you want to define the pricing</p> <p><b>Note:</b></p> <p>This field appears only when the <b>Multi Price Parameter</b> option type of the <b>Multi Parameter Based Pricing (C1_PPARM_FLG)</b> feature configuration is set to true.</p> <p>The <b>Search</b> (🔍) icon appears corresponding to this field. On clicking the search icon, the <b>Parameter Search</b> screen appears.</p> <p>If you want to define more than one parameter, click the <b>Add</b> (+) icon corresponding to this field.</p> <p>If you want to remove a parameter, click the <b>Delete</b> (🗑️) icon corresponding to this field.</p>

Field Name	Field Description
Parameter Value	<p>Displays the value of the parameter or used to specify multiple parameter value.</p> <p><b>Note:</b></p> <p>The <b>Search</b>  icon appears corresponding to this field appears only when the value type for the <b>Parameter</b> is defined as <b>Reference</b> or <b>Predefined</b>. If the value type of the <b>Parameter</b> is <b>Reference</b>, then the <b>Reference Parameter Value Search</b> screen appears and if the value type of the <b>Parameter</b> is <b>Predefined</b>, then the <b>Predefined Parameter Value Search</b> screen appears.</p> <p>If you want to define more than one value, click the <b>Add</b>  icon corresponding to this field.</p> <p>If you want to remove a parameter value, click the <b>Delete</b>  icon corresponding to this field.</p>

After providing the required information, when you click on **Simulate** button, the **Effective Pricing Information** zone appears where you can view the effective pricing simulation. This zone contains the following sections:

- **Rate Information** — This section contains the following fields:

Field Name	Field Description
Applicable Rate	Displays the rate applicable for which pricing is defined.
Contributing Price Components are	Displays how the price components are contributed.

**Note:** This section appears only when **Price Item Type** is **Rate** .

- **Fee Information** — This section contains the following fields:

Field Name	Field Description
Applicable Fee	Displays the fee applicable for which pricing is defined.
Contributing Price Components are	Displays how the price components are contributed.

**Note:** This section appears only when **Price Item Type** is **Fees** .

- **Price Item and Parameter Information** — This section contains the following fields:

Field Name	Field Description
Price Item	Displays the price item for which pricing is defined.
Description	Displays the description of the price item

The Parameter Information appears only when the **Multi Price Parameter** option type of the **Multi Parameter Based Pricing (C1\_PPARM\_FLG)** feature configuration is set to **True**.

This segment contains the following fields:

Field Name	Field Description
Parameter	Specifies multiple parameter codes associated with the price items based on which pricing is defined.
Parameter Information	Displays the parameter information with concatenated comma separated values.
Parameter Value	Displays the value of the parameter.

- **TFM Information** — This section contains the following fields:

Field Name	Field Description
Ignore Transaction	Displays whether the transactions mapped to the price item is considered for billing.
Aggregation Schedule	Displays the aggregation cycle.
Aggregation Transaction	Specifies whether the transactions mapped to the price item are aggregated for billing.
Rating Criteria	Specifies how and when you rate the transaction legs mapped to the price item.

**Note:** This section appears only when the **Price Item** is available for **Pricing and Billing**.

- **Pricing Information** — This section contains the following fields.

Field Name	Field Description
Effective Start Date	Displays the date from when the price item pricing is effective.
Pricing Currency	Specifies the currency in which you define the price item pricing.
Effective End Date	Displays the date till when the price item pricing is effective.
Pricing Status	Displays the status of price assignment.
Variance Parameter	Specifies the variance based on which price item pricing is defined. <b>Note:</b> This field appears only when the <b>Multi Price Parameter</b> option type of the <b>Multi Parameter Based Pricing (C1_PPARM_FLG)</b> feature configuration is set to <b>False</b> .
Rate Schedule	Specifies the rate schedule used for defining price item pricing.
Price Assignment Type	Displays the type of price assignment.
Print Zero	Specifies whether zero pricing should be displayed in the bill.
Apply To	Displays whether the price item pricing is applied to all customers or only to the new customers.
Pricing Frequency	Displays the frequency for pricing where <b>Price Item Type</b> is fees.
Advance Pricing	Displays only if <b>Price Item</b> is defined as <b>Pricing Only</b> , <b>Price Item Type</b> is defined as <b>Fees</b> and <b>Price Assignment Type</b> is defined as <b>Post Processing</b> . The valid values are: <ul style="list-style-type: none"> <li>• Yes</li> <li>• No</li> </ul>

**Pricing Eligibility Criteria** and **Tiering Criteria** for each eligibility or tier range are displayed in following fields:

Field Name	Field Description
Rate Component Sequence	Displays the sequence number of the rate component.
Tiering Type	Displays the tiering type of the rate component.
Price Component Sequence	Specifies the sequence of price component whose rate is used for calculation.
Price Component Description	Displays the description of the rate component.
Rate	Specifies the price for the price item.
Contributing Factor	Displays the availability of contributing factor.
Eligibility/Tier Details	On clicking the <b>Add (+)</b> icon, expandable details of <b>Tiering Criteria</b> and <b>Pricing Eligibility Criteria</b> are displayed.

When you click the **Add (+)** icon, if the price component is scheduled for Flat Rate then, only **Pricing Eligibility Criteria** segment appears. If the price component is scheduled for Step or Threshold then both the segments, **Tiering Criteria** and **Pricing Eligibility Criteria** appears.

**Tiering Criteria** segment contains the following fields:

Field Name	Field Description
Tiering Criteria	Displays the tiering criteria.
Price Item	Specifies whether the price item or bundle's total usage is considered for determining the rate.
Variance Parameter	Specifies the variance based on which price item or bundle's total usage is considered for determining the rate. <b>Note:</b> This field appears only when the <b>Multi Price Parameter</b> option type of the <b>Multi Parameter Based Pricing (C1_PPARM_FLG)</b> feature configuration is set to <b>False</b> .
Price Item Parameters	Specifies the parameters based on which price item or bundle's total usage is considered for determining the rate. <b>Note:</b> This field appears only when the <b>Multi Price Parameter</b> option type of the <b>Multi Parameter Based Pricing (C1_PPARM_FLG)</b> feature configuration is set to <b>True</b> .
From	Specifies the lower limit of the tiering range.
To	Specify the upper limit of the tiering range.

**Pricing Eligibility Criteria** segment contains the following fields:

Field Name	Field Description
Sequence Number	Specifies the order in which the criteria should be executed in the rule.

Field Name	Field Description
Parameter	Specifies the left hand side parameter which you want to use along with the price item for price determination.  <b>Note:</b> This field appears only when the <b>Multi Price Parameter</b> option type of the <b>Multi Parameter Based Pricing (C1_PPARM_FLG)</b> feature configuration is set to <b>True</b> .
Operator	Specifies the relational operator to define the relation between the left hand side and right hand side parameters.
Parameter Value Type	Displays the type of pricing eligibility.
Parameter	Specifies the right hand side parameter which you want to use along with the price item for price determination.  <b>Note:</b> This field appears only when the <b>Multi Price Parameter</b> option type of the <b>Multi Parameter Based Pricing (C1_PPARM_FLG)</b> feature configuration is set to <b>True</b> .
Parameter Value	Specifies the parameter value.
Is True	Displays what should happen when the condition is true (satisfied).
Is False	Displays what should happen when the condition is false (not satisfied).
Is Sufficient	Displays what should happen when the data is insufficient.

This section contains the following links:

Link Name	Link Description
Expand All	Used to define all the <b>Tiering Criteria</b> and <b>Pricing Eligibility Criteria</b> segments.
Collapse All	Used to un-define the displayed <b>Tiering Criteria</b> and <b>Pricing Eligibility Criteria</b> segments.
Expand Only Contributing Factors	Used to define only those <b>Tiering Criteria</b> and <b>Pricing Eligibility Criteria</b> segments with contributing factors.

### Related Topics

For more information on...	See...
How to search for effective price assignments for an account.	<a href="#">Effective Price Assignments for Account</a> on page 440
How to view effective pricing of an account	<a href="#">Viewing Effective Price Assignments of an Account</a> on page 450
How to export effective price assignments of an account	<a href="#">Exporting Effective Price Assignments of an Account</a> on page 452
<b>Price Item Pricing</b> screen	<a href="#">Price Item Pricing</a>
<b>View Price Item Pricing</b> screen	<a href="#">View Price Item Pricing</a>

## Searching Pricing Simulation for Account or Price List

### Prerequisites

To search pricing simulation for an account or price list, you should have:

- Price Item, Account or Person details defined in the application

### **Procedure**

To search pricing simulation for an account or price list:

1. Click the **Menu** link in the **Application** toolbar.  
A list appears.
2. From the **Main** menu, select **Pricing Management** and then click **Pricing Simulation**.  
The **Pricing Simulation** screen appears.
3. In the **Search Pricing** zone, select **Account** or **Price List** depending on what you want search pricing simulation.
4. Enter the additional search criteria, if required.

**Note:** ORMB search engine supports wildcard search, where you can substitute the percentage (%) symbol as a stand in for any word or letter in a search criteria. You can use the ‘%’ wildcard character in all input fields except the date and ID fields. The ‘%’ wildcard character is suffixed automatically at the end of the partial search criteria. Therefore, you may or may not specify the wildcard character at the end of the partial search criteria. However, you have to prefix the wildcard character manually wherever required.

5. Click **Search**.

A list of pricing details that meet the search criteria appears in the **Search Results** section.

### **Related Topics**

<b>For more information on...</b>	<b>See...</b>
<b>Pricing Simulation</b> screen	<a href="#">Pricing Simulation</a> on page 572
<b>Search Pricing</b> zone	<a href="#">Search Pricing</a> on page 572

## **Viewing Pricing Simulation**

### **Prerequisites**

To view pricing simulation details of an account, you should have:

- Price items assigned to the account

### **Procedure**

To view pricing simulation of an account:

1. Click the **Menu** link in the **Application** toolbar.  
A list appears.
2. From the **Main** menu, select **Pricing Management** and then click **Pricing Simulation**.  
The **Pricing Simulation** screen appears.
3. You can search for an account by entering the search criteria in the **Search Pricing** zone.

**Note:** ORMB search engine supports wildcard search, where you can substitute the percentage (%) symbol as a stand in for any word or letter in a search criteria. You can use the ‘%’ wildcard character in all input fields except the date and ID fields. The ‘%’ wildcard character is suffixed automatically at the end of the partial search criteria. Therefore, you may or may not specify the wildcard character at the end of the partial search criteria. However, you have to prefix the wildcard character manually wherever required.

### **Related Topics**

<b>For more information on...</b>	<b>See...</b>
How to search pricing details	<a href="#">Search Pricing</a> on page 572
<b>Pricing Simulation</b> screen	<a href="#">Pricing Simulation</a> on page 572
<b>Effective Pricing Information</b> screen	<a href="#">Simulation - Effective Pricing Information</a> on page 576

## **Exporting Effective Price Simulation**

### **Procedure**

To export effective price simulation for an account in the CSV format:

1. Click the **Menu** link in the **Application** toolbar.  
A list appears.
2. From the **Main** menu, select **Pricing Management** and then click **Pricing Simulation**.  
The **Pricing Simulation** screen appears.
3. You can search for an account by entering the search criteria in the **Search Pricing** zone.

**Note:** ORMB search engine supports wildcard search, where you can substitute the percentage (%) symbol as a stand in for any word or letter in a search criteria. You can use the ‘%’ wildcard character in all input fields except the date and ID fields. The ‘%’ wildcard character is suffixed automatically at the end of the partial search criteria. Therefore, you may or may not specify the wildcard character at the end of the partial search criteria. However, you have to prefix the wildcard character manually wherever required.

4. Click the **Export to Excel** link in the **Search Pricing** zone.  
The **File Download** dialog box appears.
5. Click **Save**.  
The **Save As** dialog box appears.
6. Browse to the location where you want to save the file.
7. Enter the file name in the respective field, and click **Save**.  
The search results are exported in CSV format.
8. Open the CSV file in Microsoft Excel.

It contains the following columns:

<b>Column Name</b>	<b>Column Description</b>
Price Item	Displays the price item code.
Description	Displays the description of the price item.

Column Name	Column Description
Variance	Indicates the variance parameter which is used for defining the price item pricing.  <b>Note:</b> This column appears only when the <b>Multi Price Parameter</b> option type of the <b>Multi Parameter Based Pricing (C1_PPARM_FLG)</b> feature configuration is set to <b>False</b> .
Price Item Parameters	Indicates the parameters which are used for defining the price item pricing.  <b>Note:</b> This column appears only when the <b>Multi Price Parameter</b> option type of the <b>Multi Parameter Based Pricing (C1_PPARM_FLG)</b> feature configuration is set to <b>True</b> .
Price Assignment Type	Indicates the type of price assignment. The valid values are: <ul style="list-style-type: none"> <li>• Regular</li> <li>• Post Processing</li> <li>• Post Processing — Invoice Based</li> <li>• Post Processing — Price Item Based</li> </ul>
Assignment Level	Indicates the level at which the price item pricing is defined in the customer hierarchy.
Price List Description	Displays the description of the price list.  <b>Note:</b> The description appears only when the pricing assignment type is Account Price List, Customer Price List, or Parent Customer Price List.
Rate	Displays the price of the price item. It also indicates whether the price is a Flat, Threshold, or Step price. The price can be agreed pricing, price list pricing, or pricing inherited from the price list hierarchy. If the price is applicable only to new customers, an asterisk (*) symbol appears corresponding to the price.
Price Component Description	Displays the description of the price component whose rate is used for calculation.  <b>Note:</b> The data appears in this column only when the rate corresponding to the price component in the price item pricing is used for calculation.
Effective Start Date	Displays the date from when the pricing assignment is effective.
Effective End Date	Displays the date till when the pricing assignment is effective.
Pricing Currency	Indicates the currency in which the price item pricing is defined.
From	Displays the lower limit of the tiering range.
To	Displays the upper limit of the tiering range.
Price Assignment Usage	Indicates whether the price assignment is applicable to all customers or only to the new customers.
Price Assignment ID	Displays the ID that is generated automatically when the price assignment is done.
Parent Level	Displays the numerical level of the parent in the hierarchy from whom the pricing is inherited.
Price List ID	Displays the price list ID from where the pricing is inherited.
Price List Start Date	Displays the date from when the price list is effective.



Column Name	Column Description
Parent Person	Displays the name of the parent or grandparent customer from whom the pricing is inherited.
Parent Pricelist Level	Indicates the parent level when pricing is inherited from the price list hierarchy. If the pricing is inherited from the assigned price list, the parent price list level will be 0. However, if the pricing is inherited from the parent price list in the hierarchy, the parent price list level will be 1. And, if the pricing is inherited from the grandparent price list in the hierarchy, the parent price list level will be 2, and so on.
Ignore Transaction	Indicates whether the transactions mapped to the price item should be considered for billing. The valid values are: <ul style="list-style-type: none"> <li>• Y</li> <li>• N</li> </ul>
Aggregate Transaction	Indicates whether the transactions mapped to the price item should be aggregated for billing. The valid values are: <ul style="list-style-type: none"> <li>• Y</li> <li>• N</li> </ul>
Aggregation Schedule	Indicates the aggregation cycle.
Tiering Criterion	Indicates the tiering criterion.
Tiering Price Item	Indicates whether the price item is billed individually or at the bundle level.

### Related Topics

For more information on...	See...
How to search an account	<a href="#">Searching for a Pricing Simulation Account</a>
<b>Pricing Simulation</b> screen	<a href="#">Pricing Simulation</a> on page 572

## Eligible Price List

---

The **Eligible Price List** screen allows you to:

- View eligible price list details for account or person
- View pricing simulation details of account or person

This screen consists of the following zones:

- [Search Eligible Price Lists](#) on page 585
- [Pricing Simulation](#) on page 572

### Search Eligible Price Lists

The **Search Eligible Price List** zone allows you to search eligible price list for account and person. This zone contains the following two sections:

- **Search Criteria** — The **Search Criteria** section contains the following fields:

Field Name	Field Description	Mandatory (Yes or No)
Eligible Date	Used to specify the date on which the eligibility check need to be searched.	Yes
Person ID	Used to specify the person for which eligible price list to be searched.  <b>Note:</b> The Search (🔍) icon appears corresponding to this field. On clicking the icon, the <b>Person Search</b> screen appears.	No
Account ID	Used to specify the account for which eligible price list to be searched.  <b>Note:</b> The Search (🔍) icon appears corresponding to this field. On clicking the icon, the <b>Account Search</b> screen appears.	No
Status	Used to search eligible price list based on status.	Yes
Division	Used to search eligible price list based on division.	Yes
Parameter	Used to specify multiple parameter codes based on which you want to define the pricing.  <b>Note:</b> This field appears only when the <b>MultiPrice Parameter</b> option type of the <b>MultiParameter Based Pricing (C1_PPARM_FLG)</b> feature configuration is set to True.  The Search (🔍) icon appears corresponding to this field. On clicking the icon, the <b>Parameter Search</b> screen appears.	No
Parameter Value	Displays the value of the parameter or used to specify multiple parameter value.  <b>Note:</b> The Search (🔍) icon appears corresponding to this field only when the value type for the <b>Parameter</b> is defined as <b>Reference</b> or <b>Predefined</b> . If the value type of the <b>Parameter</b> is <b>Reference</b> then on clicking the search icon, the <b>Reference Parameter Value Search</b> screen appears else if the value type of the <b>Parameter</b> is <b>Predefined</b> then on clicking the search icon, the <b>Predefined Parameter Value Search</b> screen appears.	No

**Note:** To add more than one **Parameter**, click the add (+) icon and to delete the parameters click the delete (🗑️) icon corresponding to this field.

- **Search Results** — On clicking the **Search** button, the search results appear based on the specified search criteria. The **Search Results** section contains the following columns:

Column Name	Column Description
Price List ID	Displays the price list ID. <b>Note:</b> It has a link. On clicking the link, the <b>Price List Price Item Assignments</b> screen appears where you can view the details of the respective price list.
Price List Description	Displays the price list description. <b>Note:</b> It has a link. On clicking the link, the <b>Price List Price Item Assignments</b> screen appears where you can view the details of the respective price list.
Status	Indicates the status of the price list. The valid values are: <ul style="list-style-type: none"> <li>• Active</li> <li>• Proposed</li> </ul>
Availability Start Date	Used to search price lists which are available for assignment from a particular date.
Availability End Date	Used to search price lists which are available for assignment till a particular date.
Effective Start Date	Used to search price lists which are effective from a particular date.
Effective End Date	Used to search price lists which are effective till a particular date.
Simulate	On clicking the <b>Simulate</b> (🔍) icon, the <b>Pricing Simulation Screen</b> appears with the price list ID, account and person fields prepopulated.

### Related Topics

For more information on...	See...
How to search for a price list	<a href="#">Searching for a Price List</a> on page 371
How to view price items assigned to a price list	<a href="#">Viewing Price Items Assigned to a Price List</a> on page 372
How to view the details of a price list	<a href="#">Viewing the Price List Details</a> on page 381
How to create a price list	<a href="#">Defining a Price List</a> on page 373
How to edit a price list	<a href="#">Editing a Price List</a> on page 385
How to copy a price list	<a href="#">Copying a Price List</a> on page 380

## Rate Definition

Rate schedules, rate versions, and rate components are used to define the formulas to calculate the total amount charged to a customer for a product. Some examples of formulas are: price times the number of transactions used and a flat monthly charge plus a percentage of the average daily balance.

The rate is a formula with variables whose values are supplied by a user by setting up a price list or override price. For example, a rate might add a flat monthly charge and a percentage of the average daily balance to arrive at the amount charged to the customer. This rate might be used to calculate the charge for multiple products, each product with its own flat amount and percentage. So, these two factors are defined as variables whose values must be entered by users when they setup price list or override price. In Oracle Revenue Management and Billing (ORMB), these variables are defined as rate components.

The system provides you with the ability to create tiered pricing in case standard flat pricing is not sufficient to meet the business needs. The **Rate Definition** screen allows you to indicate whether the rate component supports standard

flat pricing or tiered pricing. It allows you to define, edit, and delete the tiering setup of a rate component. This screen consists of the following zones:

- [Rate Schedule Components](#) on page 588
- [Create/Edit Rate Definition](#) on page 589

## Rate Schedule Components

The **Rate Schedule Components** zone allows you to select the rate schedule whose rate components' tiering setup you want to define or edit. This zone contains the following two sections:

- **Search Criteria** — The **Search Criteria** section contains the following field:

Field Name	Field Description	Mandatory (Yes or No)
Rate Schedule	Used to select the rate schedule.	Yes

- **Search Results** — On clicking the **Search** button, the rate components of the rate schedule appear in the search results. The **Search Results** section contains the following columns:

Column Name	Column Description
Rate Schedule	Displays the rate schedule.
Rate Component Sequence	Displays the sequence number of the rate component.
Rate Component Description	Displays the description of the rate component.
Effective Start Date	Displays the date from when the rate version to which the rate component belongs is effective.
Tiering Type	Displays the tiering type.
Maximum Tiering Combinations	Displays the maximum number of tiering ranges supported by the rate component.  <b>Note:</b> Each tiering range supports more than one tiering criteria. For example, a rate component supports tiering based on two different criteria such as transaction volumes from a bundle and balances of the priced product. In such case, for a single rate, it is possible to enter separate tiering range information for each criterion and vary this information by product.
Rate Component Map Description	Displays the description of the tiering setup of the rate component.
Action	Indicates the action that can be performed on the rate component. The valid values are: <ul style="list-style-type: none"> <li>• <b>Add</b> — Allows you to define the tiering setup of the rate component</li> <li>• <b>Edit</b> — Allows you to edit the tiering setup of the rate component</li> </ul>
Rate Component Map ID	Displays the rate component map ID.  <b>Note:</b> This ID is generated automatically when you define the tiering setup of the rate component.

On clicking the **Broadcast**  icon corresponding to the rate component, the **Create/Edit Rate Definition** zone appears with the details of the respective rate component.

**Related Topics**

For more information on...	See...
How to define tiering setup of a rate component	<a href="#">Defining Tiering Setup of a Rate Component</a> on page 590
How to edit tiering setup of a rate component	<a href="#">Editing Tiering Setup of a Rate Component</a> on page 591
How to delete tiering setup of a rate component	<a href="#">Deleting Tiering Setup of a Rate Component</a> on page 592

**Create/Edit Rate Definition**

The **Create/Edit Rate Definition** zone allows you to define and edit tiering setup of the rate component. This zone contains the following fields:

Field Name	Field Description	Mandatory (Yes or No)
Rate Schedule	Displays the code of the rate schedule.	Not applicable
Rate Component Description	Displays the description of the rate component.	Not applicable
Effective Start Date	Displays the date from when the rate version to which the rate component belongs is effective.	Not applicable
Rate Component Sequence	Displays the sequence number of the rate component.	Not applicable
Tiering Type	Used to specify the tiering type. The valid values are: <ul style="list-style-type: none"> <li>• FLAT</li> <li>• STEP</li> <li>• THRESHOLD</li> </ul> <div style="border: 1px solid black; padding: 5px; margin-top: 5px;"> <b>Note:</b> This field is non-editable when you edit the tiering setup of the rate component. </div>	Yes
Maximum Tiering Combinations	Used to specify the maximum number of tiering ranges supported by the rate component. <div style="border: 1px solid black; padding: 5px; margin-top: 5px;"> <b>Note:</b>  This field is non-editable when you: <ul style="list-style-type: none"> <li>• Select the tiering type as <b>FLAT</b> or <b>STEP</b></li> <li>• Edit the tiering setup of the rate component</li> </ul> By default, <b>0</b> appears in this field when you select the tiering type as <b>FLAT</b>, and <b>1</b> appears when you select the tiering type as <b>STEP</b>. </div>	Yes
Rate Component Map Description	Used to specify the description for the tiering setup of the rate component. For example, if you want the user to enter price per transaction for a tiering range, enter <b>Price Per Transaction</b> in the <b>Rate Component Map Description</b> field.	Yes

This zone contains the following buttons:

Button Name	Button Description (When the Action is Add)	Button Description (When the Action is Edit)
Save	Used to create the tiering setup.	Used to save the changes made in this zone.
Delete	<b>Note:</b> This button is disabled when you define the tiering setup of the rate component.	Used to delete the tiering setup of the rate component.  <b>Note:</b> You can delete the tiering setup only when the rate component is not yet used for any product pricing.
Cancel	Used to clear the fields in this zone.	Used to reset the changes made in this zone.

### Related Topics

For more information on...	See...
How to define tiering setup of a rate component	<a href="#">Defining Tiering Setup of a Rate Component</a> on page 590
How to edit tiering setup of a rate component	<a href="#">Editing Tiering Setup of a Rate Component</a> on page 591
How to delete tiering setup of a rate component	<a href="#">Deleting Tiering Setup of a Rate Component</a> on page 592

## Defining Tiering Setup of a Rate Component

### Prerequisites

To define tiering setup of a rate component, you should have:

- Rate schedules defined in the application
- Rate components of the rate schedule defined in the application

### Procedure

To define tiering setup of a rate component:

1. Click the **Menu** link in the **Application** toolbar.  
A list appears.
2. From the **Main** menu, select **Pricing Management** and then click **Rate Definition**.  
The **Rate Definition** screen appears.
3. Select the rate schedule in the **Rate Schedule Components** zone.
4. Click **Search**.  
The rate components of the rate schedule appear as the search results.
5. Click the **Broadcast**  icon corresponding to the rate component whose tiering setup you want to define.  
The **Create/Edit Rate Definition** zone appears.
6. Select the tiering type from the list.
7. Enter the maximum number of tiering ranges supported by the rate component.

#### Note:

The **Maximum Tiering Combinations** field is non-editable when you select the tiering type as **FLAT** or **STEP**. By default, **0** appears in the **Maximum Tiering Combinations** field when you select the tiering type as **FLAT**, and **1** appears when you select the tiering type as **STEP**.

- Enter the description for the tiering setup of the rate component.

For example, if you want the user to enter price per transaction for a tiering range, enter `Price Per Transaction` in the **Rate Component Map Description** field.

- Click **Save**.

The rate component map ID is generated automatically when you define the tiering setup of the rate component.

### Related Topics

For more information on...	See...
<b>Rate Definition</b> screen	<a href="#">Rate Definition</a> on page 587
<b>Rate Schedule Components</b> zone	<a href="#">Rate Schedule Components</a> on page 588
<b>Create/Edit Rate Definition</b> zone	<a href="#">Create/Edit Rate Definition</a> on page 589

## Editing Tiering Setup of a Rate Component

### Procedure

To edit tiering setup of a rate component:

- Click the **Menu** link in the **Application** toolbar.  
A list appears.
- From the **Main** menu, select **Pricing Management** and then click **Rate Definition**.  
The **Rate Definition** screen appears.
- Select the rate schedule in the **Rate Schedule Components** zone.
- Click **Search**.  
The rate components of the rate schedule appear as the search results.
- Click the **Broadcast**  icon corresponding to the rate component whose tiering setup you want to edit.  
The **Create/Edit Rate Definition** zone appears.
- Modify the details of the tiering setup.

**Note:** You can only modify the rate component map description.

- Click **Save**.

The changes made to the tiering setup are saved.

### Related Topics

For more information on...	See...
<b>Rate Definition</b> screen	<a href="#">Rate Definition</a> on page 587
<b>Rate Schedule Components</b> zone	<a href="#">Rate Schedule Components</a> on page 588
<b>Create/Edit Rate Definition</b> zone	<a href="#">Create/Edit Rate Definition</a> on page 589

## Deleting Tiering Setup of a Rate Component

### Procedure

To delete tiering setup of a rate component:

1. Click the **Menu** link in the **Application** toolbar.

A list appears.

2. From the **Main** menu, select **Pricing Management** and then click **Rate Definition**.

The **Rate Definition** screen appears.

3. Select the rate schedule in the **Rate Schedule Components** zone.

4. Click **Search**.

The rate components of the rate schedule appear as the search results.

5. Click the **Broadcast**  icon corresponding to the rate component whose tiering setup you want to delete.

The **Create/Edit Rate Definition** zone appears.

6. Click **Delete**.

The tiering setup of the rate component is deleted, and the action that can be performed on the rate component changes from **Edit** to **Add** in the **Rate Schedule Components** zone.

#### Note:

The **Delete** button is disabled when you define the tiering setup of the rate component.

You can delete the tiering setup only when the rate component is not yet used for any product pricing.

### Related Topics

For more information on...	See...
<b>Rate Definition</b> screen	<a href="#">Rate Definition</a> on page 587
<b>Rate Schedule Components</b> zone	<a href="#">Rate Schedule Components</a> on page 588
<b>Create/Edit Rate Definition</b> zone	<a href="#">Create/Edit Rate Definition</a> on page 589

## Tiering Criterion

Oracle Revenue Management and Billing (ORMB) provides you with the ability to create tiered pricing in case standard flat pricing is not sufficient to meet the business needs. Through tiered pricing, you can offer more favorable pricing to the customers based on service quantity utilization.

Let us understand this with the help of an example. ABC company uses wire transfer services provided by a large bank. If ABC company initiates up to 1,000 wire transfers, the fee charged by the bank will be \$5 per transfer. If ABC company initiates more than 1,000 wire transfers, the fee will be \$3 per transfer. To introduce this flexibility in the pricing model, you will have to define tiered pricing with the following tiering ranges:

- If the number of wire transfers is greater than 0 and less than or equal to 1000, then charge \$5 per transfer to ABC company.
- If the number of wire transfers is greater than 1000, then charge \$3 per transfer to ABC company.



In the above example, number of wire transfers is the tiering criterion, 0 – 1000 and 1000 – BLANK are tiering ranges, and \$5 and \$3 are rates per transfer.

The **Tiering Criteria** screen allows you to create and edit a tiering criterion. This screen consists of the following zones:

- [Tiering Criterion List](#) on page 593
- [Edit Tiering Criterion](#) on page 593
- [Create Tiering Criterion](#) on page 594

## Tiering Criterion List

The **Tiering Criterion List** zone displays tiering criterion that are already defined in the system. This zone contains the following columns:

Column Name	Column Description
Tiering Criterion	Displays the code of the tiering criterion.
Description	Displays the description of the tiering criterion.
Service Quantity Identifier	Displays the Service Quantity Identifier (SQI) of the tiering criterion.

You can change the layout of this zone. For more information on how to change the layout, see [Changing the Layout](#) on page 2882.

On clicking the **Broadcast**  icon corresponding to the tiering criterion, the **Edit Tiering Criterion** zone appears with the details of the respective tiering criterion.

## Edit Tiering Criterion

The **Edit Tiering Criterion** zone allows you to edit the tiering criterion. This zone contains the following fields:

Field Name	Field Description	Mandatory (Yes or No)
Tiering Criterion	Displays the code of the tiering criterion.	Not applicable
Description	Used to modify the description of the tiering criterion.	Yes
Service Quantity Identifier	Displays the Service Quantity Identifier (SQI) of the tiering criterion.	Not applicable

This zone contains the following two buttons:

Button Name	Button Description
Save	Used to save the changes made in this zone.
Cancel	Used to clear the changes made in this zone.

By default, the **Edit Tiering Criterion** zone does not appear in the **Tiering Criteria** screen. It appears only when you click the **Broadcast**  icon corresponding to the tiering criterion in the **Tiering Criteria List** zone.

### Related Topics

For more information on...	See...
How to edit a tiering criterion	<a href="#">Editing a Tiering Criterion</a> on page 595

## Create Tiering Criterion

The **Create Tiering Criterion** zone allows you to create tiering criterion. This zone contains the following fields:

Field Name	Field Description	Mandatory (Yes or No)
Tiering Criterion	Used to specify the code that uniquely identifies the tiering criterion.	Yes
Description	Used to specify the description for the tiering criterion.	Yes
Service Quantity Identifier	Used to specify the Service Quantity Identifier (SQI) for the tiering criterion.  <b>Note:</b> During billing, the rating engine uses the SQI to determine which service quantities are applied to tiers.	Yes

This zone contains the following two buttons:

Button Name	Button Description
Save	Used to create the tiering criterion.
Cancel	Used to clear the fields in this zone.

### Related Topics

For more information on...	See...
How to create a tiering criterion	<a href="#">Creating a Tiering Criterion</a> on page 594

## Creating a Tiering Criterion

### Prerequisites

To create a tiering criterion, you should have:

- Service Quantity Identifiers (SQIs) defined in the application

### Procedure

To create a tiering criterion:

1. Click the **Menu** link in the **Application** toolbar.  
A list appears.
2. From the **Main** menu, select **Pricing Management** and then click **Tiering Criterion**.  
The **Tiering Criterion** screen appears.
3. In the **Create Tiering Criterion** zone, enter the code that uniquely identifies the tiering criterion.
4. Enter the description for the tiering criterion.
5. Select the Service Quantity Identifier (SQI) that you want to associate with the tiering criterion.
6. Click **Save**.

The tiering criterion is created.

### Related Topics

For more information on...	See...
Tiering Criterion screen	<a href="#">Tiering Criterion</a> on page 592
Create Tiering Criterion zone	<a href="#">Create Tiering Criterion</a> on page 594

## Editing a Tiering Criterion

### Procedure

To edit a tiering criterion:

1. Click the **Menu** link in the **Application** toolbar.  
A list appears.
2. From the **Main** menu, select **Pricing Management** and then click **Tiering Criterion**.  
The **Tiering Criterion** screen appears.
3. In the **Tiering Criterion** zone, click the **Broadcast**  icon corresponding to the tiering criterion whose details you want to edit.  
The **Edit Tiering Criterion** zone appears.
4. Modify the description of the tiering criterion, if required.
5. Click **Save**.  
The changes made to the tiering criterion are saved.

### Related Topics

For more information on...	See...
Tiering Criterion screen	<a href="#">Tiering Criterion</a> on page 592
Edit Tiering Criterion zone	<a href="#">Edit Tiering Criterion</a> on page 593

## Variance Parameter

Oracle Revenue Management and Billing allows you to define pricing for a product based on the variance parameter. This helps you to maintain variance based pricing for a product. For example, you can define different product pricing for each country or currency, if required. Before you define product pricing based on a variance parameter, you need to define the variance parameter. The **Variance Parameter** screen allows you to define, edit, and delete a variance parameter. It also allows you to filter the variance parameters using a search criteria.

## Filtering the Variance Parameters

### Procedure

To filter the variance parameters:

1. Click the **Admin** link in the **Application** toolbar.  
A list appears.
2. From the **Admin** menu, select **V** and then click **Variance Parameter**.

The **Variance Parameter** screen appears. It contains the following two sections:

- **Search Criteria**— The **Search Criteria** section contains the following fields:

Field Name	Field Description	Mandatory (Yes or No)
Variance Parameter	Used to specify the variance parameter.	No

- **Search Results** — On clicking the **Search** button corresponding to the **Variance Parameter** field, the search results are filtered based on the specified criteria. The **Search Results** section contains the following columns:

Column Name	Column Description
Variance Parameter	Displays the variance parameter.
Description	Displays the description of the variance parameter.

3. Enter the search criteria in the **Variance Parameter** field.

**Note:** ORMB search engine supports wildcard search, where you can substitute the percentage (%) symbol as a stand in for any word or letter in a search criteria. You can use the ‘%’ wildcard character in all input fields except the date and ID fields. The ‘%’ wildcard character is suffixed automatically at the end of the partial search criteria. Therefore, you may or may not specify the wildcard character at the end of the partial search criteria. However, you have to prefix the wildcard character manually wherever required.

4. Click the **Search** button corresponding to the **Variance Parameter** field.

The search results are filtered based on the specified criteria.

### **Related Topics**

For more information on...	See...
<b>Variance Parameter</b> screen	<a href="#">Variance Parameter</a> on page 595

## **Defining a Variance Parameter**

### **Procedure**

To define a variance parameter:

1. Click the **Admin** link in the **Application** toolbar.

A list appears.

2. From the **Admin** menu, select **V** and then click **Variance Parameter**.

The **Variance Parameter** screen appears. It contains the following columns:

Column Name	Column Description	Mandatory (Yes or No)
Variance Parameter	Used to specify the variance parameter.	Yes
Description	Used to specify the description for the variance parameter.	Yes

3. Enter the required details.
4. If you want to define more than one variance parameter, click the **Add (+)** icon and then repeat step 4.

**Note:** However, if you want to remove a variance parameter, click the **Delete** (🗑️) icon corresponding to the variance parameter that you want to delete.

5. Click **Save**.

The variance parameter is defined.

**Related Topics**

For more information on...	See...
Variance Parameter screen	<a href="#">Variance Parameter</a> on page 595

## Editing a Variance Parameter

**Procedure**

To edit a variance parameter:

1. Click the **Admin** link in the **Application** toolbar.

A list appears.

2. From the **Admin** menu, select **V** and then click **Variance Parameter**.

The **Variance Parameter** screen appears.

3. If required, you can filter the variance parameters in the **Variance Parameter** screen.

A list of variance parameters that meet the search criteria appears in the search results. The **Search Results** section contains the following columns:

Column Name	Column Description	Mandatory (Yes or No)
Variance Parameter	Displays the variance parameter.	Not applicable
Description	Used to specify the description for the variance parameter.	Yes

4. Modify the required details.

5. Click **Save**.

The changes made to the variance parameter are saved.

**Related Topics**

For more information on...	See...
Variance Parameter screen	<a href="#">Variance Parameter</a> on page 595
How to filter the variance parameters	<a href="#">Filtering the Variance Parameters</a> on page 595

## Deleting a Variance Parameter

**Procedure**

To delete a variance parameter:

1. Click the **Admin** link in the **Application** toolbar.  
A list appears.
2. From the **Admin** menu, select **V** and then click **Variance Parameter**.  
The **Variance Parameter** screen appears.
3. If required, you can filter the variance parameters in the **Variance Parameter** screen.  
A list of variance parameters that meet the search criteria appears in the **Search Results** section.
4. Click the **Delete** () icon corresponding to the variance parameter that you want to delete.
5. Click **Save**.  
The variance parameter is deleted.

**Note:** You can only delete a variance parameter which is not yet used.

### Related Topics

For more information on...	See...
<b>Variance Parameter</b> screen	<a href="#">Variance Parameter</a> on page 595
How to filter the variance parameters	<a href="#">Filtering the Variance Parameters</a> on page 595

## Person to Person Relationship Type Sequence

Oracle Revenue Management and Billing provides you the flexibility to define person to person relationship type sequence:

- For each division, price item, and price item parameters combination
- For each division
- In the C1\_PER\_REL feature configuration

The system will first check whether the person to person relationship type sequence is defined for the division, price item, and price item parameters combination. If the person to person relationship type sequence is defined for the division, price item, and price item parameters combination, the system will search effective price item pricing at the parent customer level based on the sequence defined for the combination. However, if the person to person relationship type sequence is not defined for the division, price item, and price item parameters combination, the system will check whether the person to person relationship type sequence is defined for the division. If the person to person relationship type sequence is defined for the division, the system will search effective price item pricing at the parent customer level based on the sequence defined for the division. However, if the person to person relationship type sequence is not defined for the division, the system will consider the person to person relationship type sequence defined in the C1\_PER\_REL feature configuration and accordingly search effective price item pricing at the parent customer level.

The **Person to Person Relationship Type Sequence** screen allows you to define, edit, and delete person to person relationship type sequence of:

- a division
- a division, price item, and price item parameters combination

This screen consists of the following zones:

- [Search Person Relationship Type Sequence for Price Item](#) on page 599
- [Search Person Relationship Type Sequence for Division](#) on page 600

## Search Person Relationship Type Sequence for Price Item

The **Search Person Relationship Type Sequence for Price Item** zone allows you to search person to person relationship type sequence defined for a division, price item, and price item parameters combination. You can also define, edit, and delete person to person relationship type sequence of a division, price item, and price item parameters combination.

This zone contains the following two sections:

- **Search Criteria** — The **Search Criteria** section contains the following fields:

Field Name	Field Description	Mandatory (Yes or No)
Price Item	Used to specify the price item code.	No
Price Item Description	Used to specify the description of the price item.	No
Division	Used to specify the division.  <b>Note:</b> You can only view those divisions to which you have access in the <b>Division</b> list.	No

**Note:** You must specify at least one search criterion while searching person to person relationship type sequence defined for a division, price item, and price item parameters combination.

- **Search Results** — On clicking the **Search** button, the search results appear based on the specified search criteria. The **Search Results** section contains the following columns:

Column Name	Column Description
Price Item	Displays the price item code.  <b>Note:</b> It has a link. On clicking the link, the <b>View Price Item</b> screen appears with the details of the respective price item.
Description	Displays the description of the price item.
Price Item Parameters	Displays a comma-separated list of parameter values. The order in which parameter values appear in this field is controlled by the display order (which is defined while associating a parameter with a price item).
Division	Indicates the division for which price item and price item parameters specific person to person relationship type sequence is defined.
View	On clicking the <b>View</b> (🔍) icon, the <b>Person Relationship Type Sequence for Division and Price Item</b> screen appears where you can view person to person relationship type sequence defined for the division, price item, and price item parameters combination.
Edit	On clicking the <b>Edit</b> (✎) icon, the <b>Person Relationship Type Sequence for Division and Price Item</b> screen appears where you can edit person to person relationship type sequence defined for the division, price item, and price item parameters combination.
Delete	On clicking the <b>Delete</b> (🗑️) icon, you can delete person to person relationship type sequence defined for the division, price item, and price item parameters combination.

You can define person to person relationship type sequence for a division, price item, and price item parameters combination by clicking the **Add** link in the upper right corner of this zone.

**Related Topics**

For more information on...	See...
How to search person to person relationship type sequence for a division, price item, and price item parameters combination	<a href="#">Searching Relationship Type Sequence for a Division, Price Item, and Price Item Parameters</a> on page 601
How to view person to person relationship type sequence of a division, price item, and price item parameters combination	<a href="#">Viewing Relationship Type Sequence of a Division, Price Item, and Price Item Parameters</a> on page 605
How to define person to person relationship type sequence for a division, price item, and price item parameters combination	<a href="#">Defining Relationship Type Sequence for a Division, Price Item, and Price Item Parameters</a> on page 602
How to edit person to person relationship type sequence of a division, price item, and price item parameters combination	<a href="#">Editing Relationship Type Sequence of a Division, Price Item, and Price Item Parameters</a> on page 603
How to delete person to person relationship type sequence of a division, price item, and price item parameters combination	<a href="#">Deleting Relationship Type Sequence of a Division, Price Item, and Price Item Parameters</a> on page 605

**Search Person Relationship Type Sequence for Division**

The **Search Person Relationship Type Sequence for Division** zone allows you to search person to person relationship type sequence defined for a division. You can also define, edit, and delete person to person relationship type sequence of a division.

This zone contains the following two sections:

- **Search Criteria** — The **Search Criteria** section contains the following fields:

Field Name	Field Description	Mandatory (Yes or No)
Division	Used to specify the division.  <b>Note:</b> You can only view those divisions to which you have access in the <b>Division</b> list.	No

- **Search Results** — On clicking the **Search** button, the search results appear based on the specified search criteria. The **Search Results** section contains the following columns:

Column Name	Column Description
Division	Indicates the division for which person to person relationship type sequence is defined.
Description	Displays the description of the division.
View	On clicking the <b>View</b> (👁️) icon, the <b>Person Relationship Type Sequence for Division</b> screen appears where you can view person to person relationship type sequence of the division.
Edit	On clicking the <b>Edit</b> (✏️) icon, the <b>Person Relationship Type Sequence for Division</b> screen appears where you can edit person to person relationship type sequence of the division.
Delete	On clicking the <b>Delete</b> (🗑️) icon, you can delete the person to person relationship type sequence of the division.



You can define person to person relationship type sequence for a division by clicking the **Add** link in the upper right corner of this zone.

### Related Topics

For more information on...	See...
How to search person to person relationship type sequence for a division	<a href="#">Searching Relationship Type Sequence for a Division</a> on page 606
How to view person to person relationship type sequence of a division	<a href="#">Viewing Relationship Type Sequence of a Division</a> on page 609
How to define person to person relationship type sequence for a division	<a href="#">Defining Relationship Type Sequence for a Division</a> on page 607
How to edit person to person relationship type sequence of a division	<a href="#">Editing Relationship Type Sequence of a Division</a> on page 608
How to delete person to person relationship type sequence of a division	<a href="#">Deleting Relationship Type Sequence of a Division</a> on page 609

## Searching Relationship Type Sequence for a Division, Price Item, and Price Item Parameters

### Prerequisites

To search person to person relationship type sequence for a division, price item, and price item parameters combination, you should have:

- Divisions defined in the application

### Procedure

To search person to person relationship type sequence for a division, price item, and price item parameters combination:

1. Click the **Menu** link in the **Application** toolbar.  
A list appears.
2. From the **Main** menu, select **Pricing Management** and then click **Person to Person Relationship Type Sequence**.  
The **Person to Person Relationship Type Sequence** screen appears.
3. Enter the search criteria in the **Search Person Relationship Type Sequence for Price Item** zone.

**Note:** ORMB search engine supports wildcard search, where you can substitute the percentage (%) symbol as a stand in for any word or letter in a search criteria. You can use the ‘%’ wildcard character in all input fields except the date and ID fields. The ‘%’ wildcard character is suffixed automatically at the end of the partial search criteria. Therefore, you may or may not specify the wildcard character at the end of the partial search criteria. However, you have to prefix the wildcard character manually whenever required.

4. Click **Search**.

A list of division, price item, and price item parameters combinations that meet the search criteria and for which person to person relationship type sequence is defined appears in the **Search Results** section.

### Related Topics

For more information on...	See...
<b>Person to Person Relationship Type Sequence</b> screen	<a href="#">Person to Person Relationship Type Sequence</a> on page 598

<b>For more information on...</b>	<b>See...</b>
<b>Search Person Relationship Type Sequence for Price Item</b> zone	<a href="#">Search Person Relationship Type Sequence for Price Item</a> on page 599

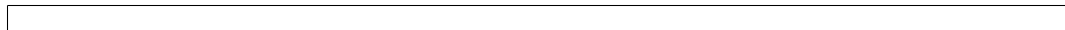

## Defining Relationship Type Sequence for a Division, Price Item, and Price Item Parameters

### Prerequisites

To define person to person relationship type sequence for a division, price item, and price item parameters combination, you should have:

- Divisions defined in the application
- Price items associated with the division to which the user belongs
- Parameters associated with the price item
- Person relationship types defined in the application

### Procedure

To define person to person relationship type sequence for a division, price item, and price item parameters combination:

1. Click the **Menu** link in the **Application** toolbar.

A list appears.

2. From the **Main** menu, select **Pricing Management** and then click **Person to Person Relationship Type Sequence**.

The **Person to Person Relationship Type Sequence** screen appears.

3. Click the **Add** link in the upper right corner of the **Search Person Relationship Type Sequence for Price Item** zone.

The **Person Relationship Type Sequence for Division and Price Item** screen appears. It contains the following fields:

Field Name	Field Description	Mandatory (Yes or No)
Division	Used to indicate the division for which you want to define price item and price item parameters specific person to person relationship type sequence.	Yes
Price Item	Used to specify the price item code.  <b>Note:</b> The <b>Search</b> (🔍) icon appears corresponding to this field. On clicking the <b>Search</b> icon, the <b>Price Item Search</b> screen appears.	Yes
Price Item Parameters	Used to specify the price item parameters.  <b>Note:</b> The <b>Search</b> (🔍) icon appears corresponding to this field. On clicking the <b>Search</b> icon, the <b>Price Item Parameters Search</b> screen appears.	No

In addition, this screen contains the following section:

- **Person Relationship Type Sequence** — This section allows you to define person to person relationship type sequence for the division, price item, and price item parameters combination. It contains the following columns:

Column Name	Column Description	Mandatory (Yes or No)
Sequence Number	Used to indicate the sequence in which relationship type should be considered while searching for effective price item pricing at the parent customer level.	Yes
Relationship Type	Used to indicate the person to person relationship type.	Yes

4. Enter the required details.

**Note:** You can search for a price item and price item parameters by clicking the **Search** (🔍) icon corresponding to the respective field.

5. If you want to define more than one relationship type in the person to person relationship type sequence, click the **Add** (+) icon and then enter the details in the **Person Relationship Type Sequence** section.

**Note:** However, if you want to remove a relationship type from the person to person relationship type sequence, click the **Delete** (🗑️) icon corresponding to the relationship type.

6. Click **Save**.

The person to person relationship type sequence is defined for the division, price item, and price item parameters combination.

### **Related Topics**

For more information on...	See...
<b>Person to Person Relationship Type Sequence</b> screen	<a href="#">Person to Person Relationship Type Sequence</a> on page 598
<b>Search Person Relationship Type Sequence for Price Item</b> zone	<a href="#">Search Person Relationship Type Sequence for Price Item</a> on page 599
How to search for a price item	<a href="#">Searching for a Price Item or Price Item Bundle</a> on page 322
How to set price item parameters	<a href="#">Defining Parameters for a Price Item Pricing</a> on page 406

## **Editing Relationship Type Sequence of a Division, Price Item, and Price Item Parameters**

### **Prerequisites**

To edit person to person relationship type sequence of a division, price item, and price item parameters combination, you should have:

- Person relationship types defined in the application

### **Procedure**

To edit person to person relationship type sequence of a division, price item, and price item parameters combination:

1. Search person to person relationship type sequence for the division, price item, and price item parameters combination in the **Person to Person Relationship Type Sequence** screen.

- In the **Search Results** section, click the **Edit** () icon in the **Edit** column corresponding to the division, price item, and price item parameters combination whose person to person relationship type sequence you want to edit.

The **Person Relationship Type Sequence for Division and Price Item** screen appears. It contains the following fields:

Field Name	Field Description	Mandatory (Yes or No)
Division	Indicates the division for which price item and price item parameters specific person to person relationship type sequence is defined.	Not applicable
Price Item	Displays the price item code.	Not applicable
Price Item Parameters	Displays a comma-separated list of parameter values. The order in which parameter values appear in this field is controlled by the display order (which is defined while associating a parameter with a price item).	Not applicable

In addition, this screen contains the following section:

- Person Relationship Type Sequence** — This section allows you to define person to person relationship type sequence for the division, price item, and price item parameters combination. It contains the following columns:

Column Name	Column Description	Mandatory (Yes or No)
Sequence Number	Used to indicate the sequence in which relationship type should be considered while searching for effective price item pricing at the parent customer level.	Yes
Relationship Type	Used to indicate the person to person relationship type.	Yes

- If you want to define more than one relationship type in the person to person relationship type sequence, click the **Add** () icon and then enter the details in the **Person Relationship Type Sequence** section.

**Note:** However, if you want to remove a relationship type from the person to person relationship type sequence, click the **Delete** () icon corresponding to the relationship type.

- Click **Save**.

The changes made to the person to person relationship type sequence are saved.

### Related Topics

For more information on...	See...
How to search person to person relationship type sequence for a division, price item, and price item parameters combination	<a href="#">Searching Relationship Type Sequence for a Division, Price Item, and Price Item Parameters</a> on page 601

## Deleting Relationship Type Sequence of a Division, Price Item, and Price Item Parameters

### Procedure

To delete person to person relationship type sequence of a division, price item, and price item parameters combination:

1. Search person to person relationship type sequence for the division, price item, and price item parameters combination in the **Person to Person Relationship Type Sequence** screen.
2. In the **Search Results** section, click the **Delete** (🗑️) icon in the **Delete** column corresponding to the division, price item, and price item parameters combination whose person to person relationship type sequence you want to delete.

A message appears confirming whether you want to delete the person to person relationship type sequence.

3. Click **OK**.

The person to person relationship type sequence of the division, price item, and price item parameters combination is deleted.

### Related Topics

For more information on...	See...
How to search person to person relationship type sequence for a division, price item, and price item parameters combination	<a href="#">Searching Relationship Type Sequence for a Division, Price Item, and Price Item Parameters</a> on page 601

## Viewing Relationship Type Sequence of a Division, Price Item, and Price Item Parameters

### Procedure

To view person to person relationship type sequence of a division, price item, and price item parameters combination:

1. Search person to person relationship type sequence for the division, price item, and price item parameters combination in the **Person to Person Relationship Type Sequence** screen.
2. In the **Search Results** section, click the **View** (🔍) icon in the **View** column corresponding to the division, price item, and price item parameters combination whose person to person relationship type sequence you want to view.

The **Person Relationship Type Sequence for Division and Price Item** screen appears. It contains the following fields:

Field Name	Field Description
Division	Indicates the division for which price item and price item parameters specific person to person relationship type sequence is defined.
Price Item	Displays the price item code.
Price Item Parameters	Displays a comma-separated list of parameter values. The order in which parameter values appear in this field is controlled by the display order (which is defined while associating a parameter with a price item).

In addition, this screen contains the following section:

- **Person Relationship Type Sequence** — This section allows you to view person to person relationship type sequence defined for the division, price item, and price item parameters combination. It contains the following columns:

Column Name	Column Description
Sequence Number	Indicates the sequence in which relationship type will be considered while searching for effective price item pricing at the parent customer level.
Relationship Type	Indicates the person to person relationship type.

3. View the person to person relationship type sequence defined for the division, price item, and price item parameters combination in the **Person Relationship Type Sequence for Division and Price Item** screen.

### Related Topics

For more information on...	See...
How to search person to person relationship type sequence for a division, price item, and price item parameters combination	<a href="#">Searching Relationship Type Sequence for a Division, Price Item, and Price Item Parameters</a> on page 601

## Searching Relationship Type Sequence for a Division

### Prerequisites

To search person to person relationship type sequence for a division, you should have:

- Divisions defined in the application

### Procedure

To search person to person relationship type sequence for a division:

1. Click the **Menu** link in the **Application** toolbar.  
A list appears.
2. From the **Main** menu, select **Pricing Management** and then click **Person to Person Relationship Type Sequence**.  
The **Person to Person Relationship Type Sequence** screen appears.
3. Enter the search criteria in the **Search Person Relationship Type Sequence for Division** zone.

**Note:** ORMB search engine supports wildcard search, where you can substitute the percentage (%) symbol as a stand in for any word or letter in a search criteria. You can use the ‘%’ wildcard character in all input fields except the date and ID fields. The ‘%’ wildcard character is suffixed automatically at the end of the partial search criteria. Therefore, you may or may not specify the wildcard character at the end of the partial search criteria. However, you have to prefix the wildcard character manually whenever required.

4. Click **Search**.

A list of divisions that meet the search criteria and for which person to person relationship type sequence is defined appears in the **Search Results** section.

### Related Topics

For more information on...	See...
<b>Person to Person Relationship Type Sequence</b> screen	<a href="#">Person to Person Relationship Type Sequence</a> on page 598

<b>For more information on...</b>	<b>See...</b>
<b>Search Person Relationship Type Sequence for Division</b> zone	<a href="#">Search Person Relationship Type Sequence for Division</a> on page 600

## Defining Relationship Type Sequence for a Division

### Prerequisites

To define person to person relationship type sequence for a division, you should have:

- Divisions defined in the application

### Procedure

To define person to person relationship type sequence for a division:

1. Click the **Menu** link in the **Application** toolbar.  
A list appears.
2. From the **Main** menu, select **Pricing Management** and then click **Person to Person Relationship Type Sequence**.  
The **Person to Person Relationship Type Sequence** screen appears.
3. Click the **Add** link in the upper right corner of the **Search Person Relationship Type Sequence for Division** zone.

The **Person Relationship Type Sequence for Division** screen appears. It contains the following fields:

Field Name	Field Description	Mandatory (Yes or No)
Division	Used to indicate the division for which you want to define person to person relationship type sequence.	Yes

In addition, this screen contains the following section:

- **Person Relationship Type Sequence** — This section allows you to define person to person relationship type sequence for the division. It contains the following columns:

Column Name	Column Description	Mandatory (Yes or No)
Sequence Number	Used to indicate the sequence in which relationship type should be considered while searching for effective price item pricing at the parent customer level.	Yes
Relationship Type	Used to indicate the person to person relationship type.	Yes

4. Enter the required details.
5. If you want to define more than one relationship type in the person to person relationship type sequence, click the **Add** (+) icon and then enter the details in the **Person Relationship Type Sequence** section.

**Note:** However, if you want to remove a relationship type from the person to person relationship type sequence, click the **Delete** (🗑️) icon corresponding to the relationship type.

6. Click **Save**.

The person to person relationship type sequence is defined for the division.

**Related Topics**

For more information on...	See...
<b>Person to Person Relationship Type Sequence</b> screen	<a href="#">Person Relationship Type Sequence</a> on page 279
<b>Search Person Relationship Type Sequence for Division</b> zone	<a href="#">Search Person Relationship Type Sequence for Division</a> on page 600

**Editing Relationship Type Sequence of a Division****Procedure**

To edit person to person relationship type sequence of a division:

1. Search person to person relationship type sequence for the division in the **Person to Person Relationship Type Sequence** screen.
2. In the **Search Results** section, click the **Edit**  icon in the **Edit** column corresponding to the division whose person to person relationship type sequence you want to edit.

The **Person Relationship Type Sequence for Division** screen appears. It contains the following fields:

Field Name	Field Description	Mandatory (Yes or No)
Division	Indicates the division for which person to person relationship type sequence is defined.	Not applicable

In addition, this screen contains the following section:

- **Person Relationship Type Sequence** — This section allows you to define person to person relationship type sequence for the division. It contains the following columns:

Column Name	Column Description	Mandatory (Yes or No)
Sequence Number	Used to indicate the sequence in which relationship type should be considered while searching for effective price item pricing at the parent customer level.	Yes
Relationship Type	Used to indicate the person to person relationship type.	Yes

3. If you want to define more than one relationship type in the person to person relationship type sequence, click the **Add**  icon and then enter the details in the **Person Relationship Type Sequence** section.

**Note:** However, if you want to remove a relationship type from the person to person relationship type sequence, click the **Delete**  icon corresponding to the relationship type.

4. Click **Save**.

The changes made to the person to person relationship type sequence are saved.

**Related Topics**



For more information on...	See...
How to search person to person relationship type sequence for a division	<a href="#">Searching Relationship Type Sequence for a Division</a> on page 606

## Deleting Relationship Type Sequence of a Division

### Procedure

To delete person to person relationship type sequence of a division:

1. Search person to person relationship type sequence for the division in the **Person to Person Relationship Type Sequence** screen.
2. In the **Search Results** section, click the **Delete** (🗑️) icon in the **Delete** column corresponding to the division whose person to person relationship type sequence you want to delete.

A message appears confirming whether you want to delete the person to person relationship type sequence.

3. Click **OK**.

The person to person relationship type sequence of the division is deleted.

### Related Topics

For more information on...	See...
How to search person to person relationship type sequence for a division	<a href="#">Search Person Relationship Type Sequence for Division</a> on page 600

## Viewing Relationship Type Sequence of a Division

### Procedure

To view person to person relationship type sequence of a division:

1. Search person to person relationship type sequence for the division in the **Person to Person Relationship Type Sequence** screen.
2. In the **Search Results** section, click the **View** (👁️) icon in the **View** column corresponding to the division whose person to person relationship type sequence you want to view.

The **Person Relationship Type Sequence for Division** screen appears. It contains the following fields:

Field Name	Field Description
Division	Indicates the division for which person to person relationship type sequence is defined.

In addition, this screen contains the following section:

- **Person Relationship Type Sequence** — This section allows you to view person to person relationship type sequence defined for the division. It contains the following columns:

Column Name	Column Description
Sequence Number	Indicates the sequence in which relationship type will be considered while searching for effective price item pricing at the parent customer level.
Relationship Type	Indicates the person to person relationship type.

- View the person to person relationship type sequence defined for the division in the **Person Relationship Type Sequence for Division** screen.

### Related Topics

For more information on...	See...
How to search person to person relationship type sequence for a division	<a href="#">Search Person Relationship Type Sequence for Division</a> on page 600

## Multiple Parameter Based Post-Processing Pricing

Until now, while deriving the post-processing bill segments, the system aggregated the regular bill segments of related price items without considering the price item parameters. Now, if you specify a price item parameter while associating regular price items with a post-processing price item and if the pricing for the post-processing price item is based on the price item parameter, the system aggregates the bill segments of regular price item and price item parameter combination. The system searches for the exact match. In this case, if the exact match is not found, the system does not aggregate the bill segments of the related price item. For example, the PR1 post processing price item is associated with the following regular price items:

Regular Price Item	Price Item Parameter
R1	Country = US
R2	Country = US

And, the pricing for PR1 post processing price item is based on Country = US. Now, if the following bill segments are generated for R1 and R2 in a bill:

Bill Segment	Price Item	Parameter 1	Parameter 2
BS1	R1	Country = US	-
BS2	R1	Country = US	Currency = USD
BS3	R1	Country = US	-
BS4	R1	-	-
BS5	R2	Country = US	-
BS6	R2	Country = US	-

Then, the system will aggregate the following regular bill segments while creating the post-processing bill segment for PR1:

- BS1
- BS3
- BS5

- BS6

However, if you specify a price item parameter while associating regular price items with a post-processing price item, but the pricing for the post-processing price item is not based on the price item parameter, the system aggregates all bill segments of regular price item irrespective of the price item parameter. For example, the PR1 post processing price item is associated with the following regular price items:

Regular Price Item	Price Item Parameter
R1	Country = US
R2	-

And, the pricing for PR1 post processing price item is not based on a price item parameter. Now, if the following bill segments are generated for R1 and R2 in a bill:

Bill Segment	Price Item	Parameter 1	Parameter 2
BS1	R1	Country = US	-
BS2	R1	Country = US	Currency = USD
BS3	R1	Country = US	-
BS4	R1	-	-
BS5	R2	Country = US	-
BS6	R2	-	-

Then, the system will aggregate the following regular bill segments while creating the post-processing bill segment for PR1:

- BS1
- BS2
- BS3
- BS4
- BS5
- BS6



---

# Chapter

# 6

---

## Division

---

### Topics:

- [Division](#)

The following two types of divisions are used while defining a contract type:

- **General Ledger (GL) Division** — GL divisions typically comprise of individual entities (for example, companies) in the general ledger. You must set up a GL division for each such entity. The GL division is used to define the accounting period for financial transactions linked to contracts. Contracts are associated with GL divisions through their contract type. The system uses accounting periods to prevent a user from creating financial transactions in the closed periods. It also uses accounting periods when it generates the flat file that contains the consolidated journal entry that is interfaced to the general ledger.
- **Division** — A division is associated with a jurisdiction. A jurisdiction is a geographic-oriented entity with unique business rules. For example, if you conduct business in California and Japan, each jurisdiction has different set of rules, and therefore you need to have a separate jurisdiction for each division. You must set up a division for each jurisdiction in which you conduct the business. For the Pricing Management functionality, setting up a division is mandatory, and the system must contain information about at least one division.

A division is associated with the following:

- **Person** — You may or may not associate person to a division. It is optional. But, when you are using division specific functionality, you have to associate person to a division while creating a local person.
- **Contract** — Contract is associated to a division through its contract type. The contract type controls multiple business rules which are defined for a given jurisdiction and contract type combination. In addition to controlling the business rules defined on the contract's contract type, the contract's division also controls the type of collection criteria used to determine if and how to collect overdue debt.
- **Account** — The division on account when combined with the account's customer class defines the jurisdiction that governs financial business rules (for example, the bill's due date, when and how late payment charges are calculated, etc.). It also allows you to assign To Do entries associated with the account to a given To Do role based on the account's division.

## Division

---

The **Division** screen allows you to define, edit, and delete a division. It consists of the following tabs:

Tab Name	Tab Description	Mandatory (Yes or No)
Main	Used to define basic details of a division.	Yes
Access Groups	Used to define the users who have right to associate objects (such as persons, accounts, price items, price lists, etc.) with this division. The users can only view those divisions to which they have access in the <b>Division</b> list used across the application.	No
Price Items	Used to define which price items are available to persons or accounts in a division.  <b>Note:</b> Once the price item is created, you need to associate it with a division.	No
Price Lists	Used to define which price lists are available to persons or accounts in a division.  <b>Note:</b> Once the price list is created, you need to associate it with a division.  You can associate a price list with a division only when all price items in the price list are already associated with the division.	No
Languages	Used to limit the languages that you can select for a person's bills and correspondence in a division.	No
Invoice Currencies	Used to limit the invoice currencies that you can select for accounts in a division.  <b>Note:</b> Invoice currency is a currency in which the accounts in the division can be billed.	No
Person Identifier Types	Used to limit the person identifier types that you can select for persons in a division.	No

Tab Name	Tab Description	Mandatory (Yes or No)
Algorithms	<p>Used to associate algorithms with the division. Once a division is created, you must associate the <b>Price Assignment Search</b> algorithm to it. For the Banking functionality, this is required to ensure that the price item pricing is displayed in the correct order as defined by the algorithm. Each division can have unique hierarchy order or more than one division can have the same hierarchy order. The hierarchy order is also used in billing when the price determination is controlled by the sort order definition of the algorithm.</p> <p>You can define algorithms in the <b>Algorithm</b> screen. The search order is governed by the second parameter of the algorithm, and the valid values for the same are:</p> <ul style="list-style-type: none"> <li>• <b>AGREED_PRICELIST</b> - If you use this search order, the price item pricing is searched in the following order: Account Agreed, Account Price List, Account Inherited Price List, Customer Agreed, Customer Price List, Customer Inherited Price List, Parent Customer Agreed, Parent Customer Price List, and Parent Customer Inherited Price List.</li> </ul> <div data-bbox="607 961 1105 1104" style="border: 1px solid black; padding: 5px;"> <p><b>Note:</b> In this search order, the account agreed level has highest precedence and parent customer inherited price list level has lowest precedence.</p> </div> <ul style="list-style-type: none"> <li>• <b>AGREED_FIRST</b> - If you use this search order, the price item pricing is searched in the following order: Account Agreed, Customer Agreed, Parent Customer Agreed, Account Price List, Account Inherited Price List, Customer Price List, Customer Inherited Price List, Parent Customer Price List, and Parent Customer Inherited Price List.</li> </ul> <div data-bbox="607 1394 1105 1537" style="border: 1px solid black; padding: 5px;"> <p><b>Note:</b> In this search order, the account agreed level has highest precedence and parent customer inherited price list level has lowest precedence.</p> </div>	No
Characteristics	Used to define characteristics for a division.	No
Bill Messages	Used to specify the bill messages that are valid for accounts in a division.	No
Party Char Types	Used to limit the characteristic types that you can select for persons and accounts in a division.	No
Bill Cycles	Used to limit the bill cycles that you can select for accounts in a division.	No
Account Identifier Types	Used to limit the account identifier types that you can select for accounts in a division.	No

Tab Name	Tab Description	Mandatory (Yes or No)
Price Item Characteristics	Used to define division-specific characteristics for price items associated with the division.	No

### **Related Topics**

For more information on...	See...
How to define a division	<a href="#">Defining a Division</a> on page 624
How to associate access groups with a division	<a href="#">Associating an Access Group with a Division</a> on page 627
How to associate price items with a division	<a href="#">Associating a Price Item with a Division</a> on page 628
How to associate price lists with a division	<a href="#">Associating a Price List with a Division</a> on page 630
How to associate languages with a division	<a href="#">Associating a Language with a Division</a> on page 631
How to associate invoice currencies with a division	<a href="#">Associating an Invoice Currency with a Division</a> on page 632
How to associate person identifier types with a division	<a href="#">Associating a Person Identifier Type with a Division</a> on page 634
How to associate algorithms with a division	<a href="#">Associating an Algorithm with a Division</a> on page 635
How to define characteristics for a division	<a href="#">Defining a Characteristic for a Division</a> on page 641
How to associate bill messages with a division	<a href="#">Associating a Bill Message with a Division</a> on page 642
How to associate party characteristic types with a division	<a href="#">Associating a Party Characteristic Type with a Division</a> on page 644
How to associate bill cycles with a division	<a href="#">Associating a Bill Cycle with a Division</a> on page 645
How to associate account identifier types with a division	<a href="#">Associating an Account Identifier Type with a Division</a> on page 646
How to define division-specific characteristics for a price item	<a href="#">Defining a Division-Specific Characteristic for a Price Item</a> on page 647

## **Division - Main**

The **Main** tab displays the basic information about the division. It contains the following fields:

Field Name	Field Description
Division	Indicates the division.  <b>Note:</b> The Search  icon appears corresponding to the <b>Division</b> field. On clicking the <b>Search</b> icon, the <b>Division Search</b> window appears where you can search for a division.
Description	Displays the description of the division.
Work Calendar	Indicates the work calendar which is associated with the division.



Field Name	Field Description
Status	Indicates the status of the division. The valid values are: <ul style="list-style-type: none"> <li>Active</li> <li>Pending</li> <li>Retired</li> </ul>
Bill Format	Indicates the format in which the bills should be printed for the accounts which belong to the division. The valid values are: <ul style="list-style-type: none"> <li>Detailed</li> <li>Summary</li> </ul>
Bill Route Type	Indicates how the bills must be sent to the main customer of the accounts which belong to the division.
Base Currency	Indicates the currency in which the GL entries should be created for the accounts which belong to the division.
Time Zone	Indicates the time zones in which the division is operational.
Eligible for Accrual	Indicates whether accrual should be calculated for the accounts which belong to the division.
Accrual Cycle	Indicates the accrual cycle of the accounts which belong to the division.
Comments	Displays additional details about the division.
Business Object	Indicates the business object using which the division is created in the system.

In addition, the **Main** tab contains the following fields in a grid:

Field Name	Field Description
To Do Type	Indicates the To Do type for which division-specific To Do role is defined.
To Do Role	Indicates the To Do role whose users must receive the To Do entries of the specified To Do type for the accounts which belong to the division.

### Related Topics

For more information on...	See...
How to define a division	<a href="#">Defining a Division</a> on page 624

## Division - Access Groups

The **Access Groups** tab lists the access groups which are associated with the division. It contains the following field:

Field Name	Field Description
Division	Indicates the division.

In addition, the following fields appear in a grid:

Field Name	Field Description
Access Group	Indicates the access group which is associated with the division.

Field Name	Field Description
Description	Displays the description of the access group.

**Related Topics**

For more information on...	See...
How to associate an access group with a division	<a href="#">Associating an Access Group with a Division</a> on page 627

**Division - Price Items**

The **Price Items** tab lists the price items which are associated with the division. It contains the following field:

Field Name	Field Description
Division	Indicates the division.

In addition, the following fields appear in a grid:

Field Name	Field Description
Price Item	Indicates the price item which is associated with the division.
Description	Displays the description of the price item.
Accrual Type Criteria	Indicates whether the billable charges of the price item should be considered for accrual depending on the accrual criteria specified in the accrual type. The valid values are: <ul style="list-style-type: none"> <li>• Actual</li> <li>• Historical</li> <li>• Not Applicable</li> </ul>

**Related Topics**

For more information on...	See...
How to associate a price item with a division	<a href="#">Associating a Price Item with a Division</a> on page 628

**Division - Price Lists**

The **Price Lists** tab lists the price lists which are associated with the division. It contains the following field:

Field Name	Field Description
Division	Indicates the division.

In addition, the following fields appear in a grid:

Field Name	Field Description
Price List ID	Indicates the price list.
Description	Displays the description of the price list.

**Related Topics**

For more information on...	See...
How to associate a price list with a division	<a href="#">Associating a Price List with a Division</a> on page 630

## Division - Languages

The **Languages** tab lists the languages which you can select for generating invoice and correspondence for the accounts in the division. It contains the following field:

Field Name	Field Description
Division	Indicates the division.

In addition, the following field appears in a grid:

Field Name	Field Description
Language	Indicates the language associated with the division.

### Related Topics

For more information on...	See...
How to associate a language with a division	<a href="#">Associating a Language with a Division</a> on page 631

## Division - Invoice Currencies

The **Invoice Currencies** tab lists the currencies which you can use for generating the invoice of the accounts in the division. It contains the following field:

Field Name	Field Description
Division	Indicates the division.

In addition, the following fields appear in a grid:

Field Name	Field Description
Currency	Indicates the currency.
Rounding Type	Indicates the rounding type for the currency. The valid values are: <ul style="list-style-type: none"> <li>• Down</li> <li>• Nearest</li> <li>• Up</li> </ul>

### Related Topics

For more information on...	See...
How to associate an invoice currency with a division	<a href="#">Associating an Invoice Currency with a Division</a> on page 632

## Division - Person Identifier Types

The **Person Identifier Types** tab lists the identifier types which are valid for the persons associated with the division. It contains the following field:

Field Name	Field Description
Division	Indicates the division.

In addition, the following field appears in a grid:

Field Name	Field Description
Person Identifier Type	Indicates the person identifier type.

#### **Related Topics**

For more information on...	See...
How to associate a person identifier type with a division	<a href="#">Associating a Person Identifier Type with a Division</a> on page 634

## **Division - Algorithms**

The **Algorithms** tab lists the algorithms which are associated with the division. It contains the following field:

Field Name	Field Description
Division	Indicates the division.

In addition, the following fields appear in a grid:

Field Name	Field Description
Division Algorithm Entity	Indicates the algorithm entity to which you want to attach the algorithm.
Sequence Number	Displays the order in which the algorithms with the same entity should be executed.
Algorithm	Indicates the algorithm.
Description	Displays the description of the algorithm.

#### **Related Topics**

For more information on...	See...
How to associate an algorithm with a division	<a href="#">Associating an Algorithm with a Division</a> on page 635

## **Division - Characteristics**

The **Characteristics** tab lists the characteristics which are defined for the division. It contains the following field:

Field Name	Field Description
Division	Indicates the division.

In addition, the following fields appear in a grid:

Field Name	Field Description
Effective Date	Indicates the date from when the characteristic is effective for the division.
Characteristic Type	Indicates the characteristic type.

Field Name	Field Description
Characteristic Value	Indicates the value for the characteristic type.

### **Related Topics**

For more information on...	See...
How to define a characteristic for a division	<a href="#">Defining a Characteristic for a Division</a> on page 641

## **Division - Bill Messages**

The **Bill Messages** tab lists the bill messages which are valid for the accounts in the division for a specified duration. It contains the following field:

Field Name	Field Description
Division	Indicates the division.

In addition, the following fields appear in a grid:

Field Name	Field Description
Start Date	Indicates the date from when you want the bill message to appear on the bill.
End Date	Indicates the date till when you want the bill message to appear on the bill.
Bill Message	Indicates the bill message that is valid for the accounts in the division.
Description	Displays the description of the bill message.

### **Related Topics**

For more information on...	See...
How to associate a bill message with a division	<a href="#">Associating a Bill Message with a Division</a> on page 642

## **Division - Party Char Types**

The **Party Char Types** tab lists the characteristic types which are valid for the persons and accounts associated with the division. It contains the following field:

Field Name	Field Description
Division	Indicates the division.

In addition, the following fields appear in a grid:

Field Name	Field Description
Characteristic Entity	Indicates whether the characteristic type is valid for a person or an account in this division.
Characteristic Type	Indicates the characteristic type.

### **Related Topics**

For more information on...	See...
How to associate a party char type with a division	<a href="#">Associating a Party Characteristic Type with a Division</a> on page 644

## Division - Bill Cycles

The **Bill Cycles** tab lists the bill cycles which are valid for the accounts associated with the division. It contains the following field:

Field Name	Field Description
Division	Indicates the division.

In addition, the following field appears in a grid:

Field Name	Field Description
Bill Cycle	Indicates the bill cycle.

### Related Topics

For more information on...	See...
How to associate a bill cycle with a division	<a href="#">Associating a Bill Cycle with a Division</a> on page 645

## Division - Account Identifier Types

The **Account Identifier Types** tab lists the identifier types which are valid for the accounts associated with the division. It contains the following field:

Field Name	Field Description
Division	Indicates the division.

In addition, the following field appears in a grid:

Field Name	Field Description
Account Identifier Type	Indicates the account identifier type.

### Related Topics

For more information on...	See...
How to associate an account identifier type with a division	<a href="#">Associating an Account Identifier Type with a Division</a> on page 646

## Division - Price Item Characteristics

The **Price Item Characteristics** tab lists division-specific characteristics of price items which are associated with the division. It contains the following field:

Field Name	Field Description
Division	Indicates the division.

In addition, the following fields appear in a grid:

Field Name	Field Description
Price Item	Displays the price item count associated with the selected division to which the user belongs.
Price Item	Displays the price item associated with the division to which the user belongs.
Effective Date	Indicates the date from when the price item characteristic is effective for the division.
Characteristic Type	Indicates the characteristic type.
Characteristic Value	Displays the value for the characteristic type.

### **Related Topics**

For more information on...	See...
How to define a division-specific characteristic for a price item	<a href="#">Defining a Division-Specific Characteristic for a Price Item</a> on page 647

## Searching for a Division

### **Procedure**

To search for a division:

1. Click the **Admin** link in the **Application** toolbar.  
A list appears.
2. From the **Admin** menu, select **D** and then click **Division**.  
A sub-menu appears.
3. Click the **Search** option from the **Division** sub-menu.

The **Division Search** window appears. It contains the following two sections:

- **Search Criteria** - The **Search Criteria** section contains the following fields:

Field Name	Field Description	Mandatory (Yes or No)
Division	Used to search for a particular division.	No
Description	Used to search division with a particular name.	No

**Note:** You must specify at least one search criterion while searching for a division.

- **Search Results** - On clicking the **Search** button corresponding to the respective field, the search results appear based on the specified search criteria. The **Search Results** section contains the following columns:

Column Name	Column Description
Division	Displays the division.
Description	Displays the description of the division.

**Note:** ORMB search engine supports wildcard search, where you can substitute the percentage (%) symbol as a stand in for any word or letter in a search criteria. You can use the ‘%’ wildcard character in all input fields except the date and ID fields. The ‘%’ wildcard character is suffixed automatically at the end of the partial search criteria. Therefore, you may or may not specify the wildcard character at the end of the partial search criteria. However, you have to prefix the wildcard character manually wherever required.

- In the **Search Results** section, click the division whose details you want to view or edit.

The **Division** screen appears.

### Related Topics

For more information on...	See...
<b>Division</b> screen	<a href="#">Division</a> on page 614

## Defining a Division

### Prerequisites

To define a division, you should have:

- Required division business object defined in the application
- Work calendars, bill route types, currencies, time zones, accrual cycles, To Do types, and To Do roles defined in the application
- Values defined for the **BILL\_FORMAT\_FLG** lookup field

### Procedure

To define a division:



- Click the **Admin** link in the **Application** toolbar.  
A list appears.
- From the **Admin** menu, select **D** and then click **Division**.  
A sub-menu appears.
- Click the **Add** option from the **Division** sub-menu.  
The **Division** screen appears.
- Ensure that the **Main** tab is selected.

The **Main** tab contains the following fields:



Field Name	Field Description	Mandatory (Yes or No)
Division	Used to specify the division.	Yes
Description	Used to specify the description for the division.	Yes
Work Calendar	Used to indicate the work calendar that you want to associate with the division. The work calendar indicates the days when the division is operational. It is used to ensure that the system calculated dates (for example, bill due date, credit and collection event dates, etc.) fall on a working day.  <b>Note:</b> The list includes only those work calendars which are already defined in the system.	Yes



Field Name	Field Description	Mandatory (Yes or No)
Status	<p>Used to indicate the status of the division. The valid values are:</p> <ul style="list-style-type: none"> <li>• <b>Active</b> - Indicates that you can use the division in the system.</li> <li>• <b>Pending</b> - Indicates that the division is not yet available for use.</li> <li>• <b>Retired</b> - Indicates that the division is no longer available for use.</li> </ul> <p><b>Note:</b> The list includes only those statuses which are defined in the <b>DIVISION_STATUS_FLG</b> lookup field.</p>	No
Bill Format	<p>Used to specify the format in which the bills should be printed for the accounts which belong to the division. The valid values are:</p> <ul style="list-style-type: none"> <li>• Detailed</li> <li>• Summary</li> </ul> <p><b>Note:</b> The list includes only those bill formats which are defined in the <b>BILL_FORMAT_FLG</b> lookup field.</p>	No
Bill Route Type	<p>Used to indicate how the bills must be sent to the main customer of the accounts which belong to the division.</p> <p><b>Note:</b> The list includes only those bill route types which are already defined in the system.</p>	No
Base Currency	<p>Used to specify the currency in which the GL entries should be created for the accounts which belong to the division. If the account's invoice currency and division's base currency are different, the system converts the GL amount from the account's invoice currency to the division's base currency. In such cases, the system creates the financial transactions for the accounts in both the currencies (i.e. account's invoice currency and division's base currency).</p> <p><b>Note:</b> The list includes only those currencies which are already defined in the system.</p>	Yes
Time Zone	<p>Used to indicate the time zone in which the division is operational.</p> <p><b>Note:</b> The list includes only those time zones which are already defined in the system.</p>	No

Field Name	Field Description	Mandatory (Yes or No)
Eligible for Accrual	Used to indicate whether you can calculate accrual for the accounts which belong to the division.	No
Accrual Cycle	Used to indicate the accrual cycle for the accounts which belong to the division.  <div style="border: 1px solid black; padding: 5px;"> <p><b>Note:</b> This field is enabled when the <b>Eligible for Accrual</b> option is selected.</p> <p>The <b>Search</b>  icon appears corresponding to the <b>Accrual Cycle</b> field. On clicking the <b>Search</b> icon, the <b>Accrual Cycle Search</b> window appears.</p> </div>	Yes (Conditional)  <div style="border: 1px solid black; padding: 5px;"> <p><b>Note:</b> The field is required when the <b>Eligible for Accrual</b> option is selected.</p> </div>
Comments	Used to specify additional details about the division.	No
Business Object	Used to indicate the business object using which you want to create the division.  <div style="border: 1px solid black; padding: 5px;"> <p><b>Note:</b> The <b>Search</b>  icon appears corresponding to the <b>Business Object</b> field. On clicking the <b>Search</b> icon, the <b>Business Object Search</b> window appears.</p> </div>	Yes

In addition, the **Main** tab contains the following fields in a grid:

Field Name	Field Description	Mandatory (Yes or No)
To Do Type	Used to indicate the To Do type for which you want to define division-specific To Do role.  <div style="border: 1px solid black; padding: 5px;"> <p><b>Note:</b> The <b>Search</b>  icon appears corresponding to the <b>To Do Type</b> field. On clicking the <b>Search</b> icon, the <b>To Do Type Search</b> window appears.</p> </div>	Yes (Conditional)  <div style="border: 1px solid black; padding: 5px;"> <p><b>Note:</b> This field is required when you are defining the division-specific To Do role for a To Do type.</p> </div>
To Do Role	Used to indicate the To Do role whose users must receive the To Do entries of the specified To Do type for the accounts which belong to the division.  <div style="border: 1px solid black; padding: 5px;"> <p><b>Note:</b> The <b>Search</b>  icon appears corresponding to the <b>To Do Role</b> field. On clicking the <b>Search</b> icon, the <b>Role for To Do Type</b> window appears.</p> </div>	Yes (Conditional)  <div style="border: 1px solid black; padding: 5px;"> <p><b>Note:</b> This field is required when you are defining the division-specific To Do role for a To Do type.</p> </div>

5. Enter the required details in the **Main** tab.
6. Associate access groups, price items, price lists, languages, invoice currencies, person identifier types, algorithms, bill messages, party characteristic types, bill cycles, and account identifier types with the division, if required.
7. Define characteristics for the division, if required.
8. Define division-specific characteristics for the price items, if required.

- Click the **Save** button in the **Page Title** area.

The division is defined. The status of the division is set to **Pending**.

### Related Topics

For more information on...	See...
<b>Division</b> screen	<a href="#">Division</a> on page 614
<b>Main</b> tab	<a href="#">Division - Main</a> on page 616
How to associate an access group with a division	<a href="#">Associating an Access Group with a Division</a> on page 627
How to associate a price item with a division	<a href="#">Associating a Price Item with a Division</a> on page 628
How to associate a price list with a division	<a href="#">Associating a Price List with a Division</a> on page 630
How to associate a language with a division	<a href="#">Associating a Language with a Division</a> on page 631
How to associate an invoice currency with a division	<a href="#">Associating an Invoice Currency with a Division</a> on page 632
How to associate a person identifier type with a division	<a href="#">Associating a Person Identifier Type with a Division</a> on page 634
How to associate an algorithm with a division	<a href="#">Associating an Algorithm with a Division</a> on page 635
How to define a characteristic for a division	<a href="#">Defining a Characteristic for a Division</a> on page 641
How to associate a bill message with a division	<a href="#">Associating a Bill Message with a Division</a> on page 642
How to associate a party characteristic type with a division	<a href="#">Associating a Party Characteristic Type with a Division</a> on page 644
How to associate a bill cycle with a division	<a href="#">Associating a Bill Cycle with a Division</a> on page 645
How to associate an account identifier type with a division	<a href="#">Associating an Account Identifier Type with a Division</a> on page 646
How to define a division-specific characteristic for a price item	<a href="#">Defining a Division-Specific Characteristic for a Price Item</a> on page 647

## Associating an Access Group with a Division

On associating an access group with a division, the users which belong to the access group can view the division in the respective list across the system. These users can then create and edit the accounts of the division.

### Prerequisites

To associate an access group with a division, you should have:

- Access groups defined in the application

### Procedure

To associate an access group with a division:

- Search for the division to which you want to associate an access group.
- Click the **Access Groups** tab in the **Division** screen.

The **Access Groups** tab appears. It contains the following field:

Field Name	Field Description
Division	Indicates the division.  <b>Note:</b> The <b>Search</b> (  ) icon appears corresponding to the <b>Division</b> field. On clicking the <b>Search</b> icon, the <b>Division Search</b> window appears where you can search for a division.

In addition, it contains the following fields in a grid:

Field Name	Field Description	Mandatory (Yes or No)
Access Group	Used to indicate the access group which you want to associate with the division.  <b>Note:</b> The <b>Search</b> (  ) icon appears corresponding to the <b>Access Group</b> field. On clicking the <b>Search</b> icon, the <b>Access Group Search</b> window appears.  On specifying an access group, the description of the access group appears in the <b>Description</b> field.	Yes (Conditional)  <b>Note:</b> This field is required when you are associating an access group with the division.
Description	Displays the description of the access group.	Not applicable

- Enter the required details in the **Access Groups** tab.
- If you want to associate more than one access group with the division, click the **Add** () icon and then repeat step 3.

**Note:** However, if you want to remove an access group from the division, click the **Delete** () icon corresponding to the access group.

- Click the **Save** button in the **Page Title** area.

The access group is associated with the division.

### Related Topics

For more information on...	See...
How to search for a division	<a href="#">Searching for a Division</a> on page 623
<b>Division</b> screen	<a href="#">Division</a> on page 614
<b>Access Groups</b> tab	<a href="#">Division - Access Groups</a> on page 617
How to define a division	<a href="#">Defining a Division</a> on page 624

## Associating a Price Item with a Division

On associating a price item with a division, you can assign the price item to the persons and accounts which belong to the division. While associating a price item with a division, you can specify the accrual type criteria for the price item. The accrual type criteria is referred only when the accrual is calculated for an account using an accrual type where the **Price Item Accrual Criteria Required** option is selected. The system behaves in the following manner when the **Price Item Accrual Criteria Required** option is selected in the accrual type:

If the accrual type criteria is set to...	Then...
Actual	The system considers the billable charges of the price item only when the accrual is calculated for an account using the accrual type where the accrual criteria is set to <b>Actual</b> .
Historical	The system considers the billable charges of the price item only when the accrual is calculated for an account using the accrual type where the accrual criteria is set to <b>Historical</b> .

### Prerequisites

To associate a price item with a division, you should have:

- Price items defined in the application

### Procedure

To associate a price item with a division:

1. Search for the division to which you want to associate a price item.
2. Click the **Price Items** tab in the **Division** screen.

The **Price Items** tab appears. It contains the following field:

Field Name	Field Description
Division	Indicates the division.  <b>Note:</b> The <b>Search</b>  icon appears corresponding to the <b>Division</b> field. On clicking the <b>Search</b> icon, the <b>Division Search</b> window appears where you can search for a division.

In addition, it contains the following fields in a grid:

Field Name	Field Description	Mandatory (Yes or No)
Price Item	Used to indicate the price item which you want to associate with the division.  <b>Note:</b> The <b>Search</b>  icon appears corresponding to the <b>Price Item</b> field. On clicking the <b>Search</b> icon, the <b>Price Item Search</b> window appears. On specifying a price item, the description of the price item appears in the <b>Description</b> field.	Yes (Conditional)  <b>Note:</b> This field is required when you are associating a price item with the division.
Description	Displays the description of the price item.	Not applicable

Field Name	Field Description	Mandatory (Yes or No)
Accrual Type Criteria	<p>Used to indicate whether the billable charges of the price item should be considered for accrual depending on the accrual criteria specified in the accrual type. The valid values are:</p> <ul style="list-style-type: none"> <li>• <b>Actual</b> <ul style="list-style-type: none"> <li>- Used to indicate that the billable charges of the price item should be considered for accrual when the accrual criteria in the accrual type is set to <b>Actual</b>.</li> </ul> </li> <li>• <b>Historical</b> <ul style="list-style-type: none"> <li>- Used to indicate that the billable charges of the price item should be considered for accrual when the accrual criteria in the accrual type is set to <b>Historical</b>.</li> </ul> </li> <li>• <b>Not Applicable</b> <ul style="list-style-type: none"> <li>- Used to indicate that the billable charges of the price item should be considered for accrual irrespective of the accrual criteria specified in the accrual type</li> </ul> </li> </ul>	No

3. Enter the required details in the **Price Items** tab.
4. If you want to associate more than one price item with the division, click the **Add (+)** icon and then repeat step 3.

**Note:** However, if you want to remove a price item from the division, click the **Delete (🗑)** icon corresponding to the price item.

5. Click the **Save** button in the **Page Title** area.  
The price item is associated with the division.

### **Related Topics**

For more information on...	See...
How to search for a division	<a href="#">Searching for a Division</a> on page 623
<b>Division</b> screen	<a href="#">Division</a> on page 614
<b>Price Items</b> tab	<a href="#">Division - Price Items</a> on page 618
How to define a division	<a href="#">Defining a Division</a> on page 624

## **Associating a Price List with a Division**

### **Prerequisites**

To associate a price list with a division, you should have:

- Price lists defined in the application

### **Procedure**

To associate a price list with a division:

1. Search for the division to which you want to associate a price list.
2. Click the **Price Lists** tab in the **Division** screen.

The **Price Lists** tab appears. It contains the following field:

Field Name	Field Description
Division	<p>Indicates the division.</p> <p><b>Note:</b> The <b>Search</b>  icon appears corresponding to the <b>Division</b> field. On clicking the <b>Search</b> icon, the <b>Division Search</b> window appears where you can search for a division.</p>

In addition, it contains the following fields in a grid:

Field Name	Field Description	Mandatory (Yes or No)
Price List ID	<p>Used to specify the price list which you want to associate with the division.</p> <p><b>Note:</b></p> <p>The <b>Search</b>  icon appears corresponding to this field. On clicking the <b>Search</b> icon, the <b>Price List Search</b> window appears.</p> <p>On specifying a price list, the description of the price list appears in the <b>Description</b> field.</p>	<p>Yes (Conditional)</p> <p><b>Note:</b> This field is required when you are associating a price list with a division.</p>
Description	Displays the description of the price list.	Not applicable

3. Enter the required details in the **Price Lists** tab.
4. If you want to associate more than one price list with the division, click the **Add**  icon and then repeat step 3.

**Note:** However, if you want to remove a price list from the division, click the **Delete**  icon corresponding to the price list.

5. Click the **Save** button in the **Page Title** area.

The price list is associated with the division.

### **Related Topics**

For more information on...	See...
How to search for a division	<a href="#">Searching for a Division</a> on page 623
<b>Price Lists</b> tab	<a href="#">Division - Price Lists</a> on page 618
<b>Division</b> screen	<a href="#">Division</a> on page 614
How to define a division	<a href="#">Defining a Division</a> on page 624

## **Associating a Language with a Division**

### **Prerequisites**

To associate a language with a division, you should have:

- Languages defined in the application

### **Procedure**

To associate a language with a division:

1. Search for the division to which you want to associate a language.
2. Click the **Languages** tab in the **Division** screen.

The **Languages** tab appears. It contains the following field:

Field Name	Field Description
Division	Indicates the division.  <b>Note:</b> The <b>Search</b>  icon appears corresponding to the <b>Division</b> field. On clicking the <b>Search</b> icon, the <b>Division Search</b> window appears where you can search for a division.

In addition, it contains the following field in a grid:

Field Name	Field Description	Mandatory (Yes or No)
Language	Used to specify the language which you want to select for generating invoice and correspondence for the accounts in the division.	No

3. Select the language from the list.
4. If you want to associate more than one language with the division, click the **Add**  icon and then repeat step 3.

**Note:** However, if you want to remove a language from the division, click the **Delete**  icon corresponding to the language.

5. Click the **Save** button in the **Page Title** area.

The language is associated with the division.

### **Related Topics**

For more information on...	See...
How to search for a division	<a href="#">Searching for a Division</a> on page 623
<b>Languages</b> tab	<a href="#">Division - Languages</a> on page 619
<b>Division</b> screen	<a href="#">Division</a> on page 614
How to define a division	<a href="#">Defining a Division</a> on page 624

## **Associating an Invoice Currency with a Division**

### **Prerequisites**

To associate an invoice currency with a division, you should have:

- Currencies defined in the application

### **Procedure**

To associate an invoice currency with a division:



1. Search for the division to which you want to associate an invoice currency.
2. Click the **Invoice Currencies** tab in the **Divisions** screen.

The **Invoice Currencies** tab appears. It contains the following field:

Field Name	Field Description
Division	Indicates the division.  <b>Note:</b> The <b>Search</b>  icon appears corresponding to the <b>Division</b> field. On clicking the <b>Search</b> icon, the <b>Division Search</b> window appears where you can search for a division.

In addition, it contains the following fields in a grid:

Field Name	Field Description	Mandatory (Yes or No)
Currency	Used to indicate the currency which you want to use for generating the invoice of the accounts in the division.	Yes (Conditional)  <b>Note:</b> This field is required when you are associating an invoice currency with the division.
Rounding Type	Used to indicate the rounding type for the currency. The valid values are: <ul style="list-style-type: none"> <li>• Down</li> <li>• Nearest</li> <li>• Up</li> </ul>	Yes (Conditional)  <b>Note:</b> This field is required when you are associating an invoice currency with the division.

3. Select the currency and its rounding type from the respective list.
4. If you want to associate more than one invoice currency with the division, click the **Add**  icon and then repeat step 3.

**Note:** However, if you want to remove an invoice currency from the division, click the **Delete**  icon corresponding to the currency.

5. Click the **Save** button in the **Page Title** area.

The invoice currency is associated with the division.

### Related Topics

For more information on...	See...
How to search for a division	<a href="#">Searching for a Division</a> on page 623
<b>Invoice Currencies</b> tab	<a href="#">Division - Invoice Currencies</a> on page 619
<b>Division</b> screen	<a href="#">Division</a> on page 614
How to define a division	<a href="#">Defining a Division</a> on page 624

## Associating a Person Identifier Type with a Division

### Prerequisites

To associate a person identifier type with a division, you should have:

- Person identifier types defined in the application

### Procedure

To associate a person identifier type with a division:

1. Search for the division to which you want to associate a person identifier type.
2. Click the **Person Identifier Types** tab in the **Division** screen.

The **Person Identifier Types** tab appears. It contains the following field:

Field Name	Field Description
Division	Indicates the division.  <b>Note:</b> The Search  icon appears corresponding to the <b>Division</b> field. On clicking the <b>Search</b> icon, the <b>Division Search</b> window appears where you can search for a division.

In addition, it contains the following field in a grid:

Field Name	Field Description	Mandatory (Yes or No)
Person Identifier Type	Used to indicate the person identifier type.	Yes (Conditional)  <b>Note:</b> This field is required when you are associating a person identifier type with a division.

3. Select the person identifier type from the list.
4. If you want to associate more than one person identifier type with the division, click the **Add**  icon and then repeat step 3.

**Note:** However, if you want to remove a person identifier type from the division, click the **Delete**  icon corresponding to the person identifier type.

5. Click the **Save** button in the **Page Title** area.

The person identifier type is associated with the division.

### Related Topics

For more information on...	See...
How to search for a division	<a href="#">Searching for a Division</a> on page 623
<b>Person Identifier Types</b> tab	<a href="#">Division - Person Identifier Types</a> on page 619
<b>Division</b> screen	<a href="#">Division</a> on page 614
How to define a division	<a href="#">Defining a Division</a> on page 624

## Associating an Algorithm with a Division

### Prerequisites

To associate an algorithm with a division, you should have:

- Required algorithms defined in the application

### Procedure

To associate an algorithm with a division:

1. Search for the division to which you want to associate the algorithm.

The **Division** screen appears.

2. Click the **Algorithms** tab.

The **Algorithms** tab appears. It contains the following field:

Field Name	Field Description
Division	Indicates the division.  <b>Note:</b> The <b>Search</b>  icon appears corresponding to the <b>Division</b> field. On clicking the <b>Search</b> icon, the <b>Division Search</b> window appears where you can search for a division.

In addition, it contains the following fields in a grid:

Field Name	Field Description	Mandatory (Yes or No)
Division      Algorithm Entity	<p>Used to indicate the algorithm entity to which you want to attach the algorithm. The valid values are:</p> <ul style="list-style-type: none"> <li>• <b>ASL Accumulation Post-Processing</b> - Used to attach an algorithm which must be triggered for undertaking some post-processing activities on the aggregate stop-loss accumulation amount. This algorithm is invoked when you execute the <b>C1-ACASL</b> batch.</li> </ul> <div style="border: 1px solid black; padding: 2px; margin: 5px 0;"> <p><b>Note:</b> No algorithm types for this algorithm entity are shipped with the product. The implementation team can create custom algorithm type for this algorithm entity based on the customer requirements.</p> </div> <ul style="list-style-type: none"> <li>• <b>ASL Accumulation Pre-Processing</b> - Used to attach an algorithm which must be triggered for undertaking some pre-processing activities on the aggregate stop-loss accumulation records. This algorithm is invoked when you execute the <b>C1-ACASL</b> batch.</li> </ul> <div style="border: 1px solid black; padding: 2px; margin: 5px 0;"> <p><b>Note:</b> No algorithm types for this algorithm entity are shipped with the product. The implementation team can create custom algorithm type for this algorithm entity based on the customer requirements.</p> </div> <ul style="list-style-type: none"> <li>• <b>Account - Post Processing</b> - Used to attach an algorithm which must be triggered when you create or edit an account.</li> </ul> <div style="border: 1px solid black; padding: 2px; margin: 5px 0;"> <p><b>Note:</b> The <b>C1-CLSACCT</b> and <b>C1-UACM-IC</b> algorithm types are shipped with the product. For more information, see the algorithm type description.</p> </div> <ul style="list-style-type: none"> <li>• <b>Accrual</b> - Used to attach an algorithm which must be triggered to create the accruals for the account.</li> <li>• <b>Contract Derivation</b> - Used to attach an algorithm which must be triggered to derive active contract for the account. This algorithm is invoked when you execute the <b>C1-TXNVP</b> batch. Note that this algorithm is invoked only when the account has multiple active contracts of the contract type which is associated with the price item.</li> </ul> <div style="border: 1px solid black; padding: 2px; margin: 5px 0;"> <p><b>Note:</b> The <b>SA_DERV_POPC</b> algorithm type is shipped with the product. For more information, see the algorithm type description.</p> </div>	<p>Yes (Conditional)</p> <div style="border: 1px solid black; padding: 2px; margin-top: 10px;"> <p><b>Note:</b> This field is required when you are associating an algorithm with the division.</p> </div>

Field Name	Field Description	Mandatory (Yes or No)
	<ul style="list-style-type: none"> <li data-bbox="618 218 1122 373">• <b>Currency Conversion For Adjustments</b> - Used to attach a date or date and time based currency conversion algorithm which must be triggered while creating adjustments and FT GL entries for adjustments.   <div data-bbox="656 394 1122 573" style="border: 1px solid black; padding: 5px;"> <p><b>Note:</b> The <b>C1_CURALGAD</b> and <b>C1_EXCRTAD</b> algorithm types are shipped with the product. For more information, see the algorithm type description.</p> </div> </li> <li data-bbox="618 590 1122 745">• <b>Currency Conversion For Bill Segments</b> - Used to attach a date or date and time based currency conversion algorithm which must be triggered while creating bill segments and FT GL entries for bill segments.   <div data-bbox="656 766 1122 945" style="border: 1px solid black; padding: 5px;"> <p><b>Note:</b> The <b>C1_CURALGBS</b> and <b>C1_EXCRTBS</b> algorithm types are shipped with the product. For more information, see the algorithm type description.</p> </div> </li> <li data-bbox="618 961 1122 1150">• <b>Currency Conversion For Payments</b> - Used to attach a date or date and time based currency conversion algorithm which must be triggered while creating payments, payment tenders, and FT GL entries for payments.   <div data-bbox="656 1171 1122 1350" style="border: 1px solid black; padding: 5px;"> <p><b>Note:</b> The <b>C1_CURALGPY</b> and <b>C1_EXCRTPY</b> algorithm types are shipped with the product. For more information, see the algorithm type description.</p> </div> </li> <li data-bbox="618 1367 1122 1455">• <b>GL Account Validation</b> - Used to attach an algorithm which must be triggered during dynamic GL account validation.   <div data-bbox="656 1476 1122 1623" style="border: 1px solid black; padding: 5px;"> <p><b>Note:</b> The <b>C1-GLVAL</b> and <b>C1-GLVAL-COB</b> algorithm types are shipped with the product. For more information, see the algorithm type description.</p> </div> </li> <li data-bbox="618 1640 792 1665">• <b>GL Assign</b> -</li> <li data-bbox="618 1682 1052 1707">• <b>Generate Conditional GL Entries</b> -</li> <li data-bbox="618 1724 1122 1913">• <b>Price Assignment Eligibility</b> - Used to attach an algorithm which must be triggered to determine whether the post-processing pricing is eligible for the account. This algorithm is invoked when you execute the <b>C1-BLPPR</b> and <b>POSTPROC</b> batches.   <div data-bbox="656 1934 1122 2100" style="border: 1px solid black; padding: 5px;"> <p><b>Note:</b> This algorithm is invoked while executing these batches only when an algorithm created using the <b>C1-GENBSICPA</b></p> </div> </li> </ul>	

Field Name	Field Description	Mandatory (Yes or No)
	<ul style="list-style-type: none"> <li>• <b>Price Assignment Search</b> - Used to attach an algorithm which indicates the order in which the price item pricing must be determined while billing. It also indicates the order in which the price item pricing must be listed in the <b>Pricing (Account)</b> and <b>Pricing (Person)</b> screens.</li> </ul> <div style="border: 1px solid black; padding: 5px; margin: 10px 0;"> <p><b>Note:</b> The <b>C1_PRASN_PP</b> algorithm type is shipped with the product. For more information, see the algorithm type description.</p> </div> <ul style="list-style-type: none"> <li>• <b>Pricing Fees Calculation Post-Processing</b> -</li> <li>• <b>Pricing Fees Calculation Pre-Processing</b> -</li> <li>• <b>Pricing Rate Post-Processing</b> -</li> <li>• <b>Pricing Rate Pre-Processing</b> -</li> <li>• <b>Sequential Bill Number Generation</b> - Used to attach an algorithm which indicates how to sequence alternate bill numbers which are unique within the division.</li> </ul> <div style="border: 1px solid black; padding: 5px; margin: 10px 0;"> <p><b>Note:</b> The <b>C1_ALTBLLDIV</b> and <b>C1_ALTBLDIV1</b> algorithm types are shipped with the product. For more information, see the algorithm type description.</p> </div> <ul style="list-style-type: none"> <li>• <b>SSL Accumulation Pre-Processing</b> - Used to attach an algorithm which must be triggered for undertaking some pre-processing activities on the aggregate stop-loss accumulation records. This algorithm is invoked when you execute the <b>C1-ACSSL</b> batch.</li> </ul> <div style="border: 1px solid black; padding: 5px; margin: 10px 0;"> <p><b>Note:</b> No algorithm types for this algorithm entity are shipped with the product. The implementation team can create custom algorithm type for this algorithm entity based on the customer requirements.</p> </div> <ul style="list-style-type: none"> <li>• <b>TFM - Billable Charge Post-Processing</b> - Used to attach an algorithm which must be triggered for undertaking some post-processing activities on the billable charges which are generated through the transaction aggregation process. This algorithm is invoked when you execute the <b>C1-TXNSQ</b> and <b>C1-TXNCU</b> batches.</li> </ul> <div style="border: 1px solid black; padding: 5px; margin: 10px 0;"> <p><b>Note:</b> The <b>C1_BCHG_POPC</b> algorithm type is shipped with the product. For more information, see the algorithm type description.</p> </div> <ul style="list-style-type: none"> <li>• <b>TFM - Cancellation Pre-Processing</b> -</li> </ul>	

Field Name	Field Description	Mandatory (Yes or No)
	<ul style="list-style-type: none"> <li data-bbox="618 218 1122 342">• <b>TFM - Currency Conversion</b> - Used to attach a date or date and time based currency conversion algorithm which must be triggered while aggregating transactions.   <div data-bbox="656 363 1122 541" style="border: 1px solid black; padding: 5px;"> <p><b>Note:</b> The <b>C1_CURALGTFM</b> and <b>C1_EXCRTTFM</b> algorithm types are shipped with the product. For more information, see the algorithm type description.</p> </div> </li> <li data-bbox="618 558 1122 745">• <b>TFM - Disaggregation Pre-Processing</b> - Used to attach an algorithm which must be triggered for undertaking some pre-processing activities while disaggregating the transactions. This algorithm is invoked when you execute the <b>C1-PDTXN</b> batch.   <div data-bbox="656 766 1122 911" style="border: 1px solid black; padding: 5px;"> <p><b>Note:</b> The <b>C1_DSAG_PRPC</b> algorithm type is shipped with the product. For more information, see the algorithm type description.</p> </div> </li> <li data-bbox="618 928 1122 989">• <b>TFM - Disaggregation Request Post-Processing</b></li> <li data-bbox="618 1005 1122 1192">• <b>TFM - Price Item Derivation Post-Processing</b> - Used to attach an algorithm which must be triggered for undertaking some post-processing activities on the transaction legs. This algorithm is invoked when you execute the <b>C1-TXNIP</b> batch.   <div data-bbox="656 1213 1122 1358" style="border: 1px solid black; padding: 5px;"> <p><b>Note:</b> The <b>C1_PRDR_POPC</b> and <b>C1-VALECRTRN</b> algorithm types are shipped with the product. For more information, see the algorithm type description.</p> </div> </li> <li data-bbox="618 1375 1122 1598">• <b>TFM - Rate Post-Processing</b> - Used to attach an algorithm which must be triggered for undertaking some post-processing activities while determining rate for transaction legs. This algorithm is invoked when you execute the <b>C1-TXNEX</b> and <b>C1-TXNSQ</b> batches.   <div data-bbox="656 1619 1122 1797" style="border: 1px solid black; padding: 5px;"> <p><b>Note:</b> The <b>C1-ASOEXPOS</b> and <b>C1_RTCL_POPC</b> algorithm types are shipped with the product. For more information, see the algorithm type description.</p> </div> </li> <li data-bbox="618 1814 1122 2032">• <b>TFM - Rate Pre-Processing</b> - Used to attach an algorithm which must be triggered for undertaking some pre-processing activities while determining rate for transaction legs. This algorithm is invoked when you execute the <b>C1-TXNEX</b> and <b>C1-TXNSQ</b> batches.   <div data-bbox="656 2053 1122 2091" style="border: 1px solid black; padding: 5px;"> <p><b>Note:</b> The <b>C1-RETFLAT</b> and</p> </div> </li> </ul>	

Field Name	Field Description	Mandatory (Yes or No)
	<ul style="list-style-type: none"> <li> <b>TFM - Rollback Pre-Processing</b> - Used to attach an algorithm which must be triggered for undertaking some pre-processing activities while rolling back the transactions. This algorithm is invoked when you execute the <b>C1-TXNRB</b> batch.           <div data-bbox="656 428 1120 571" style="border: 1px solid black; padding: 5px; margin-top: 10px;"> <p><b>Note:</b> The <b>C1_ROBK_PRPC</b> algorithm type is shipped with the product. For more information, see the algorithm type description.</p> </div> </li> <li> <b>TFM - SSL Accumulation Post-Processing</b> - Used to attach an algorithm which must be triggered for undertaking some post-processing activities on the specific stop-loss accumulation amount. This algorithm is invoked when you execute the <b>C1-ACSSL</b> batch.           <div data-bbox="656 831 1120 1003" style="border: 1px solid black; padding: 5px; margin-top: 10px;"> <p><b>Note:</b> No algorithm types for this algorithm entity are shipped with the product. The implementation team can create custom algorithm type for this algorithm entity based on the customer requirements.</p> </div> </li> <li> <b>TFM - Verify Pricing Post-Processing</b> - Used to attach an algorithm which must be triggered for undertaking some post-processing activities on a summary record in the <b>CI_TXN_DTL_PRITM_SUMMARY</b> table. This algorithm is invoked when you execute the <b>C1-TXNVP</b> batch.           <div data-bbox="656 1297 1120 1440" style="border: 1px solid black; padding: 5px; margin-top: 10px;"> <p><b>Note:</b> The <b>C1-VRPR_POPC</b> algorithm type is shipped with the product. For more information, see the algorithm type description.</p> </div> </li> </ul>	
Sequence Number	Used to specify the order in which the algorithms with the same entity should be executed.	Yes (Conditional) <div data-bbox="1140 1520 1466 1633" style="border: 1px solid black; padding: 5px; margin-top: 10px;"> <p><b>Note:</b> This field is required when you are associating an algorithm with the division.</p> </div>
Algorithm	Used to specify the algorithm code. <div data-bbox="591 1709 1120 1864" style="border: 1px solid black; padding: 5px; margin-top: 10px;"> <p><b>Note:</b> The <b>Search</b>  icon appears corresponding to the <b>Algorithm</b> field. On clicking the <b>Search</b> icon, the <b>Algorithm Search</b> window appears.</p> </div>	Yes (Conditional) <div data-bbox="1140 1709 1466 1822" style="border: 1px solid black; padding: 5px; margin-top: 10px;"> <p><b>Note:</b> This field is required when you are associating an algorithm with the division.</p> </div>



Field Name	Field Description	Mandatory (Yes or No)
Description	Displays the description of the algorithm.  <b>Note:</b> The description appears automatically when you specify the algorithm code in the <b>Algorithm</b> field.	Not applicable

- Enter the required details in the **Algorithms** tab.
- If you want to associate more than one algorithm with the division, click the **Add** (+) icon and then repeat step 3.

**Note:** However, if you want to remove an algorithm from the division, click the **Delete** (🗑️) icon corresponding to the algorithm.

- Click the **Save** button in the **Page Title** area.  
The algorithm is associated with the division.

### Related Topics

For more information on...	See...
How to search for a division	<a href="#">Searching for a Division</a> on page 623
<b>Algorithms</b> tab	<a href="#">Division - Algorithms</a> on page 620
<b>Division</b> screen	<a href="#">Division</a> on page 614
How to define a division	<a href="#">Defining a Division</a> on page 624

## Defining a Characteristic for a Division

### Prerequisites

To define a characteristic for a division, you should have:

- Characteristic types defined in the application (where the characteristic entity is set to Division)

### Procedure

To define a characteristic for a division:

- Search for the division for which you want to define characteristics.
- Click the **Characteristics** tab in the **Division** screen.

The **Characteristics** tab appears. It contains the following field:

Field Name	Field Description
Division	Indicates the division.  <b>Note:</b> The <b>Search</b> (🔍) icon appears corresponding to the <b>Division</b> field. On clicking the <b>Search</b> icon, the <b>Division Search</b> window appears where you can search for a division.

In addition, it contains the following fields in a grid:

Field Name	Field Description	Mandatory (Yes or No)
Effective Date	Used to specify the date from when the characteristic is effective for the division.	Yes (Conditional) <b>Note:</b> This field is required when you are defining a characteristic for the division.
Characteristic Type	Used to indicate the characteristic type. <b>Note:</b> The list includes only those characteristic types where the characteristic entity is set to Division.	Yes (Conditional) <b>Note:</b> This field is required when you are defining a characteristic for the division.
Characteristic Value	Used to specify the value for the characteristic type. <b>Note:</b> The <b>Search</b>  icon appears corresponding to the <b>Characteristic Value</b> field. On clicking the <b>Search</b> icon, the <b>Characteristic Value Search</b> window appears. On specifying the value for a predefined characteristic type, the description of the characteristic value appears corresponding to the <b>Characteristic Value</b> field.	Yes (Conditional) <b>Note:</b> This field is required when you are defining a characteristic for the division.

- Enter the required details in the **Characteristics** tab.
- If you want to define more than one characteristic for the division, click the **Add**  icon and then repeat step 3.

**Note:** However, if you want to remove a characteristic from the division, click the **Delete**  icon corresponding to the characteristic.

- Click the **Save** button in the **Page Title** area.  
The characteristic is defined for the division.

### **Related Topics**

For more information on...	See...
How to search for a division	<a href="#">Searching for a Division</a> on page 623
<b>Characteristics</b> tab	<a href="#">Division - Characteristics</a> on page 620
<b>Division</b> screen	<a href="#">Division</a> on page 614
How to define a division	<a href="#">Defining a Division</a> on page 624

## **Associating a Bill Message with a Division**

### **Prerequisites**

To associate a bill message with a division, you should have:

- Bill messages defined in the application

### **Procedure**

To associate a bill message with a division:

1. Search for the division to which you want to associate a bill message.
2. Click the **Bill Messages** tab in the **Division** screen.

The **Bill Messages** tab appears. It contains the following field:

Field Name	Field Description
Division	Indicates the division.  <b>Note:</b> The <b>Search</b>  icon appears corresponding to the <b>Division</b> field. On clicking the <b>Search</b> icon, the <b>Division Search</b> window appears where you can search for a division.

In addition, it contains the following fields in a grid:

Field Name	Field Description	Mandatory (Yes or No)
Start Date	Used to specify the date from when you want the bill message to appear on the bill for the accounts in the division.	Yes (Conditional)  <b>Note:</b> This field is required when you are associating a bill message with the division.
End Date	Used to specify the date till when you want the bill message to appear on the bill for the accounts in the division.	No
Bill Message	Used to specify the bill message which is valid for the accounts in the division.  <b>Note:</b> The <b>Search</b>  icon appears corresponding to this field. On clicking the <b>Search</b> icon, the <b>Bill Message Search</b> window appears.  On specifying a bill message, the description of the bill message appears in the <b>Description</b> field.	Yes (Conditional)  <b>Note:</b> This field is required when you are associating a bill message with the division.
Description	Displays the description of the bill message.	Not applicable

3. Enter the required details in the **Bill Messages** tab.
4. If you want to associate more than one bill message with the division, click the **Add**  icon and then repeat step 3.

**Note:** However, if you want to remove a bill message from the division, click the **Delete**  icon corresponding to the bill message.

5. Click the **Save** button in the **Page Title** area.

The bill message is associated with the division.

### **Related Topics**

For more information on...	See...
How to search for a division	<a href="#">Searching for a Division</a> on page 623
<b>Bill Messages</b> tab	<a href="#">Division - Bill Messages</a> on page 621
<b>Division</b> screen	<a href="#">Division</a> on page 614
How to define a division	<a href="#">Defining a Division</a> on page 624

## Associating a Party Characteristic Type with a Division

### Prerequisites

To associate a party char type with a division, you should have:

- Characteristic types defined in the application (where the characteristic entity is set to Division)

### Procedure

To associate a party char type with a division:

1. Search for the division to which you want to associate a party char type.
2. Click the **Party Char Types** tab in the **Division** screen.

The **Party Char Types** tab appears. It contains the following field:

Field Name	Field Description
Division	Indicates the division.  <b>Note:</b> The <b>Search</b>  icon appears corresponding to the <b>Division</b> field. On clicking the <b>Search</b> icon, the <b>Division Search</b> window appears where you can search for a division.

In addition, it contains the following fields in a grid:

Field Name	Field Description	Mandatory (Yes or No)
Characteristic Entity	Used to indicate whether the characteristic type is valid for a person or an account in the division.	Yes (Conditional)  <b>Note:</b> This field is required when you are associating a party char type with the division.
Characteristic Type	Used to indicate the characteristic type.  <b>Note:</b> The list includes only those characteristic types where the characteristic entity is set to Division.	Yes (Conditional)  <b>Note:</b> This field is required when you are associating a party char type with the division.

3. Enter the required details in the **Party Char Types** tab.
4. If you want to associate more than one party char type with the division, click the **Add**  icon and then repeat step 3.

**Note:** However, if you want to remove a party char type from the division, click the **Delete**  icon corresponding to the characteristic type.

- Click the **Save** button in the **Page Title** area.

The party char type is associated with the division.

### Related Topics

For more information on...	See...
How to search for a division	<a href="#">Searching for a Division</a> on page 623
<b>Party Char Types</b> tab	<a href="#">Division - Party Char Types</a> on page 621
<b>Division</b> screen	<a href="#">Division</a> on page 614
How to define a division	<a href="#">Defining a Division</a> on page 624

## Associating a Bill Cycle with a Division

### Prerequisites

To associate a bill cycle with a division, you should have:

- Bill cycles defined in the application

### Procedure

To associate a bill cycle with a division:

- Search for the division to which you want to associate a bill cycle.
- Click the **Bill Cycles** tab in the **Division** screen.

The **Bill Cycles** tab appears. It contains the following field:

Field Name	Field Description
Division	Indicates the division.  <b>Note:</b> The <b>Search</b>  icon appears corresponding to the <b>Division</b> field. On clicking the <b>Search</b> icon, the <b>Division Search</b> window appears where you can search for a division.

In addition, it contains the following field in a grid:

Field Name	Field Description	Mandatory (Yes or No)
Bill Cycle	Used to specify the bill cycle that is valid for the accounts associated with the division.	Yes (Conditional)  <b>Note:</b> This field is required when you are associating a bill cycle with the division.

- Select the bill cycle from the list.
- If you want to associate more than one bill cycle with the division, click the **Add**  icon and then repeat step 3.

**Note:** However, if you want to remove a bill cycle from the division, click the **Delete**  icon corresponding to the bill cycle.

- Click the **Save** button in the **Page Title** area.

The bill cycle is associated with the division.

### Related Topics

For more information on...	See...
How to search for a division	<a href="#">Searching for a Division</a> on page 623
<b>Bill Cycles</b> tab	<a href="#">Division - Bill Cycles</a> on page 622
<b>Division</b> screen	<a href="#">Division</a> on page 614
How to define a division	<a href="#">Defining a Division</a> on page 624

## Associating an Account Identifier Type with a Division

### Prerequisites

To associate an account identifier type with a division, you should have:

- Account identifier types defined in the application

### Procedure

To associate an account identifier type with a division:

- Search for the division to which you want to associate an account identifier type.
- Click the **Account Identifier Types** tab in the **Division** screen.

The **Account Identifier Types** tab appears. It contains the following field:

Field Name	Field Description
Division	Indicates the division.  <b>Note:</b> The <b>Search</b>  icon appears corresponding to the <b>Division</b> field. On clicking the <b>Search</b> icon, the <b>Division Search</b> window appears where you can search for a division.

In addition, it contains the following field in a grid:

Field Name	Field Description	Mandatory (Yes or No)
Account Identifier Type	Used to specify the account identifier type valid for the accounts associated with the division.	Yes (Conditional)  <b>Note:</b> This field is required when you are associating an account identifier type with the division.

- Select the account identifier type from the list.
- If you want to associate more than one account identifier type with the division, click the **Add**  icon and then repeat step 3.

**Note:** However, if you want to remove an account identifier type from the division, click the **Delete**  icon corresponding to the account identifier type.

- Click the **Save** button in the **Page Title** area.

The account identifier type is associated with the division.

**Related Topics**

For more information on...	See...
How to search for a division	<a href="#">Searching for a Division</a> on page 623
<b>Account Identifier Types</b> tab	<a href="#">Division - Account Identifier Types</a> on page 622
<b>Division</b> screen	<a href="#">Division</a> on page 614
How to define a division	<a href="#">Defining a Division</a> on page 624

**Defining a Division-Specific Characteristic for a Price Item****Prerequisites**

To define a division-specific characteristics for a price item, you should have:

- Characteristic types defined in the application (where the characteristic entity is set to Division/Price Item Combination)
- Price item associated with the division to which the user belongs

**Procedure**

To define a division-specific characteristic for a price item:

1. Search for the division for which you want to define a price item characteristic.
2. Click the **Price Item Characteristics** tab in the **Division** screen.

The **Price Item Characteristics** tab appears. It contains the following field:

Field Name	Field Description
Division	Indicates the division.  <b>Note:</b> The <b>Search</b>  icon appears corresponding to the <b>Division</b> field. On clicking the <b>Search</b> icon, the <b>Division Search</b> window appears where you can search for a division.

In addition, it contains the following fields in a grid:

Field Name	Field Description	Mandatory (Yes or No)
Price Item	Indicates the price item count associated with the selected division.	No
Price Item	Indicates the price item code associated with the division to which the user belongs.	Not applicable
Effective Date	Used to specify the date from when the price item characteristic is effective for the division.	Yes (Conditional)  <b>Note:</b> This field is required when you are defining a division-specific characteristic for the price item.

Field Name	Field Description	Mandatory (Yes or No)
Characteristic Type	Used to indicate the characteristic type.  <b>Note:</b> The list includes only those characteristic types where the characteristic entity is set to Division/Price Item Combination.	Yes (Conditional)  <b>Note:</b> This field is required when you are defining a division-specific characteristic for the price item.
Characteristic Value	Used to specify the value for the characteristic type.  <b>Note:</b> If you select a predefined characteristic type, the <b>Search</b> (🔍) icon appears corresponding to the <b>Characteristic Value</b> field. On clicking the <b>Search</b> icon, the <b>Characteristic Value Search</b> window appears.  On specifying the value for a predefined characteristic type, the description of the characteristic value appears corresponding to the <b>Characteristic Value</b> field.	Yes (Conditional)  <b>Note:</b> This field is required when you are defining a division-specific characteristic for the price item.

3. If the division has multiple price items associated with it, navigate to define characteristics for the required price item.

**Note:** You can use the **Previous** (⏪) and **Next** (⏩) buttons to navigate through the price items while defining their characteristics.

4. Enter the required details in the **Price Item Characteristics** tab.
5. If you want to define more than one division-specific characteristic for the price item, click the **Add** (+) icon and then repeat step 4.

**Note:** However, if you want to remove a division-specific characteristic from the price item, click the **Delete** (🗑️) icon corresponding to the characteristic.

6. Click the **Save** button in the **Page Title** area.

The division-specific characteristic is defined for the price item.

### Related Topics

For more information on...	See...
How to search for a division	<a href="#">Searching for a Division</a> on page 623
<b>Price Item Characteristics</b> tab	<a href="#">Division - Price Item Characteristics</a> on page 622
<b>Division</b> screen	<a href="#">Division</a> on page 614
How to define a division	<a href="#">Defining a Division</a> on page 624

## Associating a To Do Type and To Do Role with a Division

### Prerequisites





To associate a To Do type and To Do role with a division, you should have:

- To Do types and to do roles defined in the application
- To Do roles associated to the respective to do types

### **Procedure**

To associate a To Do type and To Do role with a division:

1. Search for the division to which you want to associate a To Do type and To Do role.
2. Click the **Main** tab in the **Divisions** screen.  
The **Main** tab appears.
3. The **To Do** section contains the following fields in a grid:

Field Name	Field Description	Mandatory (Yes or No)
To Do Type	Used to indicate the To Do type for which you want to define division-specific To Do role.  <b>Note:</b> The <b>Search</b>  icon appears corresponding to the <b>To Do Type</b> field. On clicking the <b>Search</b> icon, the <b>To Do Type Search</b> window appears.	Yes (Conditional)  <b>Note:</b> This field is required when you are defining a To Do type for the division
To Do Role	Used to indicate the To Do role whose users must receive the To Do entries of the specified To Do type for the accounts which belong to the division.  <b>Note:</b> The <b>Search</b>  icon appears corresponding to the <b>To Do Role</b> field. On clicking the <b>Search</b> icon, the <b>Role for To Do Type</b> window appears.	Yes (Conditional)  <b>Note:</b> This field is required when you are defining a division-specific To Do role for a To Do type

4. If you want to associate more than one To Do type and To Do role with the division, click the **Add**  icon and then repeat step 3.

**Note:** However, if you want to remove a To Do type and To Do role from the division, click the **Delete**  icon corresponding to the To Do type.

5. Click the **Save** button in the **Page Title** area.

The To Do type and To Do role is associated with the division.

### **Related Topics**

For more information on...	See...
How to search for a division	<a href="#">Searching for a Division</a> on page 623
<b>Main</b> tab	<a href="#">Division - Main</a> on page 616
<b>Division</b> screen	<a href="#">Division</a> on page 614
How to define a division	<a href="#">Defining a Division</a> on page 624



---

# Chapter 7

---

## Approval Workflow

---

### Topics:

- [Most Commonly Used Terms](#)
- [Approval Workflow Process](#)
- [Prerequisites](#)
- [Approval Transaction](#)
- [Comparison: New versus Existing](#)
- [Approve Price Assignment](#)
- [Modify Price Assignment](#)
- [Resolve Price Assignment](#)
- [Approval Workflow Group \(Used for Searching\)](#)
- [Approval Workflow Group \(Used for Viewing\)](#)
- [Approval Workflow Chain \(Used for Searching\)](#)
- [Approval Workflow Chain \(Used for Viewing\)](#)
- [Approval Workflow Criterion Type \(Used for Searching\)](#)
- [Approval Workflow Criterion Type \(Used for Viewing\)](#)
- [Approval Workflow Group Chain Linkage \(Used for Searching\)](#)
- [Approval Workflow Group Chain Linkage \(Used for Viewing\)](#)
- [Approval Workflow Setting \(Used for Searching\)](#)
- [Approval Workflow Setting \(Used for Viewing\)](#)
- [Approval Workflow Reason \(Used for Searching\)](#)

Oracle Revenue Management and Billing may optionally be configured to use the approval workflow process whenever any addition, modification, or deletion is done manually by a user. The approval workflow process routes any changes made to the business objects (such as person, account, contract, division, and so on) to a group of people for approval. The approval workflow process allows you to manage and track all tasks involved in the approval process.

Approval workflow allows you to define the rules for requiring an approval step before the data changes are committed to the database. Once you establish the approval workflow rules, the application manages the business process flow for having data changes approved before they are reflected in the database.

The system provides you with a flexible set of options used to determine when approvals are required, and how the approval process is to be managed including:

- Turning approval on or off for individual business objects within the application
- Grouping business objects so that approval is required for the group rather than the individual business objects within the group
- Who should approve
- How many levels of approvals are required
- Different approval workflow chains based on different criteria

Once you have turned approval workflow on for an object, or a group of objects, the system will use the approval workflow configuration to manage the entire approval process including:

- Determining whether approval is required based on data changes submitted by a user
- Routing approval workflow requests to one or more qualified approvers
- Managing rejected data changes and sending these back to the submitter for resolution
- Committing the changes once all required approvals are received

- *Approval Workflow Reason  
(Used for Viewing)*



## Most Commonly Used Terms

---

Before you understand the approval workflow process, you must familiarize yourself with the following terms:

Term	Description
Submitter	A person who adds, modifies or deletes a business object, such as person, account, contract, and division is called a submitter.
Approver	A person who approves any changes made to a business object is called an approver.
Approval Workflow Group	A group of one or more business objects for which approval is required, under some or all conditions, when data changes are made.
Approval Workflow Chain	The approval workflow chain indicates how many levels of approvals are required to approve the changes made by the submitter.

## Approval Workflow Process

---

When a submitter adds, edits or deletes a business object (for example, an account) that belongs to an approval workflow group, the system checks whether approval workflow is activated for the approval workflow group. If the approval workflow is activated for the group, the system creates an approval workflow request. Every approval workflow request is uniquely identified in the system through the Approval Transaction ID.

The system identifies the approval workflow chain that must be used for approval depending on the pre-configured conditions or criteria. Based on the number of levels defined in the approval workflow chain, the request is sent to the approver at each level in the chain or hierarchy for approval. When the approver at the first level approves the request, a notification is sent to the approver at the second level for approval. This process continues till the approval is received from all levels in the hierarchy. Once the approvers at all levels approve the request, the changes are committed to the database.

However, if an approver at any level in the hierarchy rejects the request, a notification is sent to the submitter who has made the changes. The submitter then makes the required corrections based on the approver's comments and resubmits the changes for approval. In this case, the approval process starts once again from the beginning and not from the level at which the request was rejected.

The submitter also has the facility to modify the request before the approver at the first level in the hierarchy approves or rejects the request. Once the changes are made, the submitter submits the request for approval. The submitter also has the facility to cancel the request.

The following figure indicates the flow of the approval workflow process:

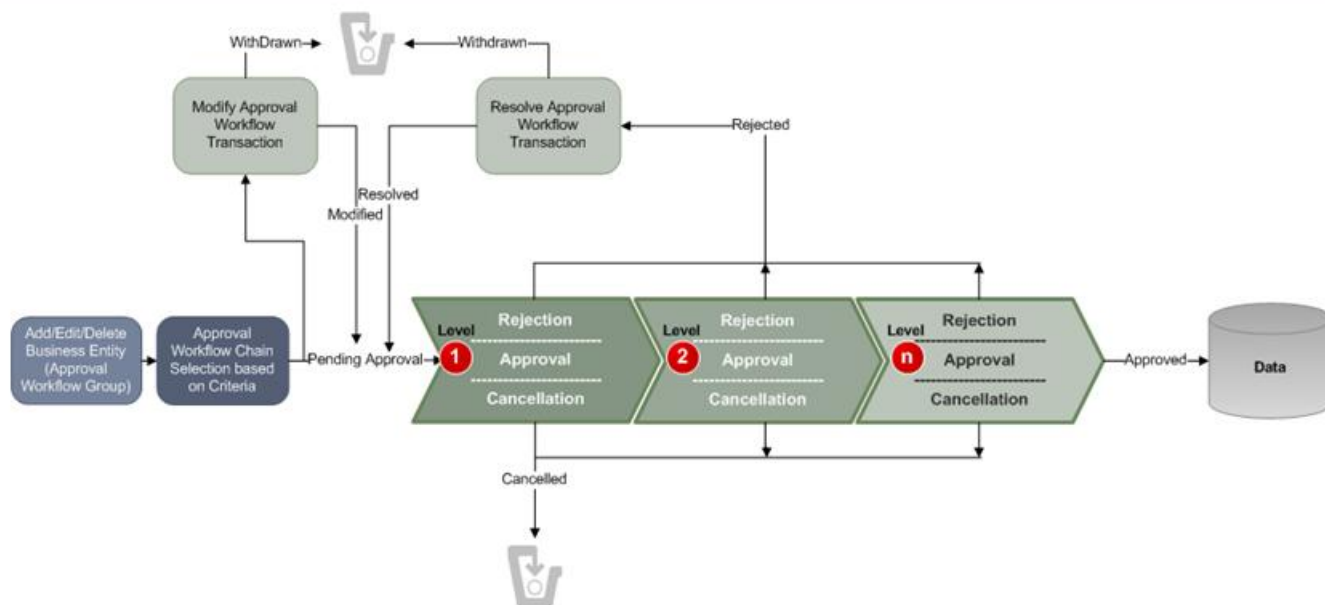

To implement the approval workflow process, you need to define the following:

- [Approval Workflow Group \(Used for Searching\)](#) on page 708
- [Approval Workflow Chain \(Used for Searching\)](#) on page 725
- [Approval Workflow Criterion Type \(Used for Searching\)](#) on page 732
- [Approval Workflow Group Chain Linkage \(Used for Searching\)](#) on page 738
- [Approval Workflow Reason \(Used for Searching\)](#) on page 755
- [Approval Workflow Setting \(Used for Searching\)](#) on page 748

For price list, price item and price assignment, the approval workflow configuration is shipped with ORMB. The following groups are available in the system:

- **C1PRODUCT** – Contains the C1\_PRICEITEM\_BO business object
- **C1PRICELST** – Contains the C1\_F\_ADDPLBO business object
- **C1PRICEASG** – Contains the C1\_PRICECOMP and C1\_PRICEASGN\_BO business objects

After creating the approval workflow chains, you need to link these groups to the corresponding approval workflow chains. To setup the approval workflow process for price assignment, you need to do the following:

For Price Item	<ol style="list-style-type: none"> <li>1. If a <b>Determine BO</b> algorithm is not specified for the <b>C1_PRICEITEM</b> maintenance object, create a <b>Determine BO</b> algorithm using the <b>F1-MOBO</b> algorithm type and specify <b>C1_PRICEITEM_BO</b> as the business object on this algorithm.</li> <li>2. Attach this algorithm on the <b>Determine BO</b> algorithm spot of the <b>C1_PRICEITEM</b> MO.</li> <li>3. Link the <b>C1PRODUCT</b> group to the appropriate approval workflow chain.</li> <li>4. Activate the approval workflow for the <b>C1PRODUCT</b> group by setting the <b>Active</b> flag corresponding to the group in the <b>Approval Workflow Settings</b> screen to <b>Y</b>.</li> </ol>
----------------	---

For Price List	<ol style="list-style-type: none"> <li>1. If a <b>Determine BO</b> algorithm is not specified for the <b>C1_PRICELIST</b> maintenance object, create a <b>Determine BO</b> algorithm using the <b>F1-MOBO</b> algorithm type and specify <b>C1_F_ADDPLBO</b> as the business object on this algorithm.</li> <li>2. Attach this algorithm on the <b>Determine BO</b> algorithm spot of the <b>C1_PRICELIST</b> MO.</li> <li>3. Link the <b>C1PRICELST</b> group to the appropriate approval workflow chain.</li> <li>4. Activate the approval workflow for the <b>C1PRICELST</b> group by setting the <b>Active</b> flag corresponding to the group in the <b>Approval Workflow Settings</b> screen to <b>Y</b>.</li> </ol>
For Price Assignments	<ol style="list-style-type: none"> <li>1. If a <b>Determine BO</b> algorithm is not specified for the <b>C1_PRICECOMP</b> maintenance object, create a <b>Determine BO</b> algorithm using the <b>F1-MOBO</b> algorithm type and specify <b>C1_PRICECOMP</b> as the business object on this algorithm.</li> <li>2. Attach this algorithm on the <b>Determine BO</b> algorithm spot of the <b>C1_PRICECOMP</b> MO.</li> <li>3. If a <b>Determine BO</b> algorithm is not specified for the <b>C1_PRICEASGN</b> maintenance object, create a <b>Determine BO</b> algorithm using the <b>F1-MOBO</b> algorithm type and specify <b>C1_PRICEASGN_BO</b> as the business object on this algorithm.</li> <li>4. Attach this algorithm on the <b>Determine BO</b> algorithm spot of the <b>C1_PRICEASGN</b> MO.</li> <li>5. Link the <b>C1PRICEASG</b> group to the appropriate approval workflow chain.</li> <li>6. Activate the approval workflow for the <b>C1PRICEASG</b> group by setting the <b>Active</b> flag corresponding to the group in the <b>Approval Workflow Settings</b> screen to <b>Y</b>.</li> </ol>

Similarly, for invoicing group, the approval workflow configuration is shipped with ORMB. The following groups are available in the system:

- **C1IGADD**
- **C1IGUPD**

After creating the approval workflow chains, you need to link these groups to the corresponding approval workflow chains, and activate the approval workflow for these groups by setting the following in the **Approval Workflow Settings** screen:

- Set **Active** flag to **Yes**
- Set **Prevalidation** flag to **Yes**

**Note:** You must set the **Active** flag to **No** for both the groups in case you do not want to activate the approval workflow for invoicing group. If you set the **Active** flag to **Yes** for either of the groups, approval workflow is triggered when you add and/or edit an invoicing group.

## Prerequisites

You need to setup the following prerequisites to implement the approval workflow process:

- **Setup Feature Configuration for Approval Workflow** — If you create new Maintenance Objects (MOs) and want the access control for these MOs in the approval workflow transactions to be based on the access group and division, then you have to create a custom algorithm and attach it to the **Approval Transaction Entity Access Algorithms** option type of the **C1\_AXENTITY** feature configuration. Note that you will then have two access algorithms; one default algorithm (that is, **C1-APPTXN**) and another custom algorithm. For more information

about the **C1\_AXENTITY** feature configuration, see [Setting the C1\\_AXENTITY Feature Configuration](#) on page 2902.

- **Create and Attach Determine BO Algorithm** — To use approval workflow for a business object, check the corresponding maintenance object to see if a **Determine BO** algorithm is already attached to it. If not, create a **Determine BO** algorithm using the **F1-MOBO** algorithm type, and specify the appropriate business object name on the newly created algorithm. Attach this algorithm on the **Determine BO** algorithm spot of the maintenance object.
- **Attach Audit Algorithm to Business Objects** — To use the approval workflow process for a business object, you need to attach the **C1-APPTXNBAS** algorithm on the **Audit** algorithm spot of the business object. Unless you attach the audit algorithm to a business object, the approval workflow process will not be triggered for the respective business object. This step is only required when you are using the base panels. If you have created custom UI maps to enter or modify data for a specific business object, this step is not needed.
- **Attach Validation Algorithms to Business Objects** — The following algorithms are shipped with ORMB:

Business Object	Basic Validation Algorithm	Pending Transaction Validation Algorithm
C1-AppBOChain	C1-GRPCHNALG	C1-APPGRPCHL
C1-AppGrp	C1-GRPALG	C1-APPGROUPV
C1-ApprovalChainEligible	C1-ADMALG	C1-APGBYPORT
C1-ApprovalTransactionChain	C1-APCHALGO	C1-APCHNPEND

The basic validation algorithms are attached to the respective business objects, and then shipped with ORMB. However, the pending transaction validation algorithms are not attached to the respective business objects. If you want to restrict the users from either editing or deleting the approval workflow group, approval workflow settings, approval workflow chain, or approval workflow group chain linkage when the respective approval workflow requests are in the **Pending**, **Work-in-Progress**, or **Rejected** state, then you must attach the pending transaction validation algorithm on the **Validation** algorithm spot of the respective business object.

- **Set Colors for Highlighting during Comparison** — While approving, rejecting, or cancelling approval workflow requests where the submitter action is Update (UPD), you will be able to compare the existing and new data. By default, any modifications are highlighted in the Yellow (9933FF) color and new additions are highlighted in the Purple (FFFF66) color. You can easily change these default colors. For more information on how to set the colors used for highlighting, see [Changing the Highlighting Colors](#).
- **Create To Do Types** — You need to create the To Do types that you want to use in the approval workflow process. Once the To Do type is created, you need to link it to the required To Do roles so that users belonging to the To Do role can view and work on the To Do type.
- **Create To Do Roles** — You need to create the To Do roles that you want to use in the approval workflow process. Once the To Do role is created, you need to add the users whom you want to assign this role.

**Note:** User who is withdrawing the approval workflow request must be assigned to the To Do role to which the approver at the first level in the hierarchy is assigned. Otherwise, the user will not be able to withdraw the approval workflow request.

- **Create Input UI Map for an Approval Workflow Group** — The system provides you with the ability to automatically generate an Input UI map, and associate it with the approval workflow group. Alternatively, you can create an Input UI map manually, and attach it to the approval workflow group. For more information on how to create an Input UI map manually, see [Creating Input UI Map for an Approval Workflow Group](#) on page 2887.
- **Create Display UI Map for an Approval Workflow Group** — The system provides you with the ability to automatically generate a Display UI map, and associate it with the approval workflow group. Alternatively, you can create a Display UI map manually, and attach it to the approval workflow group. For more information on



how to create a Display UI map manually, see [Creating Display UI Map for an Approval Workflow Group](#) on page 2886.

## Approval Transaction

If an approver at any level in the hierarchy rejects a request, a notification is sent to the submitters having the To Do role to resolve. The submitter then makes the required corrections based on the approver's comments, and resubmits the changes for approval. In this case, the approval process starts once again from the beginning, and not from the level at which the request was rejected.

The **Approval Transaction** screen allows you to resolve or withdraw a request. It consists of the following zones:

- [Search Approval Transaction](#)
- [Approval Transaction Log](#)

## Search Approval Transaction

The **Search Approval Transaction** zone allows you to search for an approval transaction using various search criteria. It contains the following two sections:

- **Search Criteria** — The **Search Criteria** section contains the following fields:

Field Name	Field Description	Mandatory (Yes or No)
Search By	Used to indicate whether you want to search for an approval transaction using the task or approval transaction details. The valid values are: <ul style="list-style-type: none"> <li>• Task Details</li> <li>• Approval Transaction Details</li> </ul> <div style="border: 1px solid black; padding: 2px;"><b>Note:</b> By default, the <b>Task Details</b> option is selected.</div>	Yes
Status	Used to search approval transactions with a particular status. The valid values are: <ul style="list-style-type: none"> <li>• Approved</li> <li>• Cancelled</li> <li>• Rejected</li> <li>• Inprocess</li> <li>• Pending</li> <li>• Deleted</li> </ul> <div style="border: 1px solid black; padding: 2px;"><b>Note:</b> This field appears only when you select the <b>Approval Transaction Details</b> option from the <b>Search By</b> list.</div>	No

Field Name	Field Description	Mandatory (Yes or No)
Task	<p>Used to search approval transactions with a particular task. The valid values are:</p> <ul style="list-style-type: none"> <li>• Approve</li> <li>• Modify</li> <li>• Resolve</li> </ul> <p><b>Note:</b> This field appears only when you select the <b>Task Details</b> option from the <b>Search By</b> list.</p>	<p>Yes (Conditional)</p> <p><b>Note:</b> This field is required when you want to search approval transactions using the task details.</p>
Approval Workflow Group	Used to search approval transactions created for the business objects that belong to a particular approval workflow group.	No
Division	<p>Used to search approval transactions which belong to a particular division.</p> <p><b>Note:</b> You can only view those divisions to which you have access in the <b>Division</b> list.</p>	No
Reference ID	Used to search approval transactions created for the business object with a particular reference ID.	No
Approval Transaction ID	Used to search for a particular approval transaction.	No
Created From	Used to search approval transactions which are created from a particular date onwards.	No
Created Until	Used to search approval transactions which are created till a particular date.	No
Action	Used to search approval transactions which are created while adding, updating, or deleting a business object.	No
Submitter ID	<p>Used to search approval transactions which are created by a particular submitter.</p> <p><b>Note:</b></p> <p>This field appears either when you select the <b>Task Details</b> from the <b>Search By</b> list and <b>Approve</b> option from the <b>Task</b> list or when you select the <b>Approval Transaction Details</b> from the <b>Search By</b> list and <b>Processing, Pending, or Deleted</b> option from the <b>Approval Transaction Status</b> list.</p> <p>The <b>Search</b> (🔍) icon appears corresponding to this field. On clicking the <b>Search</b> icon, the <b>Submitter Id for Status</b> window appears.</p>	No

Field Name	Field Description	Mandatory (Yes or No)
Approver ID	<p>Used to search approval transactions which are rejected by a particular approver.</p> <p><b>Note:</b></p> <p>The <b>Approver ID</b> is displayed when the approval transaction is searched by <b>Task Details</b> and <b>Task is Resolve</b>. It is also displayed when the approval transaction is searched by <b>Approval Transaction Details</b> and Status is <b>Approved, Canceled, or Rejected</b>.</p> <p>The <b>Search</b> (🔍) icon appears corresponding to this field. On clicking the <b>Search</b> icon, the <b>Approver ID Search</b> window appears.</p>	No

**Note:** You must specify at least one search criterion while searching for an approval transaction. One more search criterion is required when you are searching for an approval transaction using the **Task** field.

- **Search Results** - On clicking the **Search** button, the search results appear based on the specified search criteria. The **Search Results** section contains the following columns:

Column Name	Column Description
Approval Transaction ID	<p>Displays the approval transaction ID.</p> <p><b>Note:</b> It has a link. The link appears when you select <b>Task Details</b> option from the <b>Search By</b> list. If the <b>Approve</b> option is selected from the <b>Task</b> list then on clicking the link, <b>Comparison: New versus Existing</b> window appears with the compared details of the new and existing approval transactions. If the <b>Modify</b> option is selected from the <b>Task</b> list then on clicking the link, <b>Modify/Resolve Price List Assignment</b> window appears to modify or resolve the details of price list assignment. If the <b>Resolve</b> option is selected from the <b>Task</b> list then on clicking the link, <b>Modify/Resolve Price List Assignment</b> window appears to modify or resolve the details of price list assignment.</p>
Approval Workflow Group	Displays the code of the approval workflow group.
Submitter Name	<p>Displays the name of submitter who submits the approval transaction details list.</p> <p><b>Note:</b> This column appears either when you select the <b>Approve</b> or <b>Modify</b> option from the <b>Task</b> list or when you select the <b>Processing, Pending, or Deleted</b> option from the <b>Approval Transaction Status</b> list.</p>
Approver Name	<p>Displays the name of an approver who approves an approval transaction details list.</p> <p><b>Note:</b> This column appears either when you select the <b>Resolve</b> option from the <b>Task</b> list or when you select the <b>Approved, Canceled, or Rejected</b> option from the <b>Approval Transaction Status</b> list.</p>

Column Name	Column Description
Submitted On	<p>Displays the date and time on which approval transaction is submitted for approval.</p> <p><b>Note:</b> This column appears either when you select the <b>Approve</b> or <b>Modify</b> option from the <b>Task</b> list or when you select the <b>Approved</b>, <b>Pending</b>, or <b>Deleted</b> option from the <b>Approval Transaction Details</b> list.</p>
Action	<p>Indicates the various types of action. The valid values are:</p> <ul style="list-style-type: none"> <li>• Add</li> <li>• Delete (DEL)</li> <li>• Update (UPD)</li> </ul>
Division	Displays the division to which the approval transaction belongs.
Status	<p>Displays the status of approval transaction. The valid values are:</p> <ul style="list-style-type: none"> <li>• Approved</li> <li>• Cancelled</li> <li>• Rejected</li> <li>• Processing</li> <li>• Pending</li> <li>• Deleted</li> </ul> <p><b>Note:</b> This column appears either when you select <b>Approval Transaction Details</b> option from the <b>Search By</b> list of the search criteria.</p>
To Do Type	Displays the type of <b>To Do</b> (notification) received for the approval transaction.
Approval Transaction Information	Displays additional information about the approval transaction.
Rejected On	<p>Displays the date and time on which the transaction is rejected.</p> <p><b>Note:</b> This column appears either when you select the <b>Resolve</b> option from the <b>Task</b> list or when you select the <b>Rejected</b>, option from the <b>Approval Transaction Details</b> list.</p>
Reject Reason	<p>Displays the reason for which the approval transaction is rejected by the approver.</p> <p><b>Note:</b> This column appears either when you select the <b>Resolve</b> option from the <b>Task</b> list or when you select the <b>Rejected</b> option from the <b>Approval Transaction Details</b> list.</p>
Canceled On	<p>Displays the date and time on which the approval transaction is canceled by the user.</p> <p><b>Note:</b> This column appears when you select the <b>Cancelled</b> option from the <b>Approval Transaction Details</b> list.</p>

Column Name	Column Description
Cancel Reason	Displays the reason for which the approval transaction is canceled by the user.  <b>Note:</b> This column appears either when you select the <b>Canceled</b> option from the <b>Approval Transaction Details</b> list.
Withdraw	Displays a link to withdraw an approval transaction.  <b>Note:</b> This column appears either when you select the <b>Modify</b> or <b>Resolve</b> option from the <b>Task</b> list. It has a link and on clicking the link, a message appears to confirm the withdrawal of the respective approval transaction.

On clicking the **Broadcast**  icon corresponding to the approval transaction the **Approval Transaction Log** zone appears with the approval transaction log details.

### Related Topics

For more information on...	See...
<b>Approval Transaction Log</b> zone	<a href="#">Approval Transaction Log</a> on page 661
How to search for an approval transaction	<a href="#">Searching for an Approval Transaction</a> on page 662
How to view the log of an approval transaction	<a href="#">Viewing the Log of an Approval Transaction</a> on page 662

## Approval Transaction Log

The **Approval Transaction Log** zone displays the complete trail of submitter and approver actions performed on the approval transaction. It contains the following columns:

Column Name	Column Description
Date Time	Displays the date and time when the action was performed on the approval transaction.
User Name	Indicates the user who has performed the action on the approval transaction.
Status	Displays the status of the approval transaction. The valid values are: <ul style="list-style-type: none"> <li>• Approved</li> <li>• Cancelled</li> <li>• Rejected</li> <li>• InProcess</li> <li>• Pending</li> <li>• Deleted</li> </ul>
View	It has a link. On clicking the <b>View</b> link, the <b>Comparison: New versus Existing</b> window appears where you can view the existing and new compared transactions”.
Status Reason	Displays the status reason of the approval transaction.
Comments	Displays additional information about the approval transaction.

By default, the **Banking Approval Transaction Log** zone does not appear. It appears only when you click the **Broadcast**  icon corresponding to the approval transaction in the **Approval Transaction** zone.

You can change the layout of this zone. For more information on how to change the layout, see [Changing the Layout](#) on page 2882.

**Related Topics**

For more information on...	See...
How to view the log of an approval transaction	<a href="#">Viewing the Log of an Approval Transaction</a> on page 662

**Searching for an Approval Transaction****Procedure**

To search for an approval transaction:

1. Click the **Menu** link in the **Application** toolbar.  
A list appears.
2. From the **Main** menu, select **Approval Workflow Management** and then click **Approval Transaction**.  
The **Approval Transaction** screen appears.
3. Click the **Search** option from the **Approval Transaction** sub-menu.  
The **Approval Transaction** screen appears.
4. Enter the search criteria in the **Search Approval Transaction** zone depending on whether you want to search for a task or approval transaction details.

**Note:** ORMB search engine supports wildcard search, where you can substitute the percentage (%) symbol as a stand in for any word or letter in a search criteria. You can use the '%' wildcard character in all input fields except the date and ID fields. The '%' wildcard character is suffixed automatically at the end of the partial search criteria. Therefore, you may or may not specify the wildcard character at the end of the partial search criteria. However, you have to prefix the wildcard character manually wherever required.

5. Click **Search**.  
A list of task or approval transactions that meet the search criteria appears in the **Search Results** section.

**Related Topics**

For more information on...	See...
<b>Approval Transaction</b> screen	<a href="#">Approval Transaction</a> on page 657
<b>Search Approval Transaction</b> zone	<a href="#">Search Approval Transaction</a> on page 657

**Viewing the Log of an Approval Transaction****Procedure**

To view the log of an approval transaction:

1. Search for the task or approval transaction details in the **Approval Transaction** screen.
2. In the Search Results section, click the **Broadcast**  icon corresponding to the approval transaction whose log details you want to view.  
The **Approval Transaction Log** zone appears.
3. View the log details of the approval transactions in the **Approval Transaction Log** zone.

**Related Topics**

For more information on...	See...
Search Approval Transaction zone	<a href="#">Search Approval Transaction</a> on page 657
Approval Transaction Log zone	<a href="#">Approval Transaction Log</a> on page 661

## Comparison: New versus Existing

You have to define the reason codes which are used when the approval workflow request is either rejected or cancelled. The reason code helps to indicate the reason why a particular request was rejected or cancelled.

The **Comparison: New versus Existing** screen allows you to view the changes in the new approval transaction compared to the existing one. It contains the following sections:

- New
- Existing

Through this screen you can do the following:

- Approve an approval transaction
- Reject an Approval Transaction
- Cancel an approval transaction
- Modify an approval transaction
- Withdraw an Approval Transaction
- Resolve an approval transaction

## Approving an Approval Transaction

You can view the number of approval transactions which are pending for approval in the **Approval Transaction** screen. The approver can review, and accordingly approve, return to the submitter, revert to the original, or cancel the approval transaction based on the observations.

**Note:** The system will not allow you to approve, return to the submitter, revert to the original or cancel an approval transaction submitted by you.

### **Procedure**

To approve an approval transaction:

1. Search for approval transactions with task details and status as Approve in the **Approval Transaction** screen.
2. In the **Search Results** section, click the link in the **Approval Transaction ID** column corresponding to the approval transaction which you want to review.

The **Comparison: New versus Existing** screen appears.

3. Review the compared existing and new approval transactions.
4. Click **Approve**.

A message appears with confirmation on transaction approved successfully.

**Note:** ORMB search engine supports wildcard search, where you can substitute the percentage (%) symbol as a stand in for any word or letter in a search criteria. You can use the '%' wildcard character in all input fields except the date and ID fields. The '%' wildcard character is suffixed automatically at the end of the partial search criteria. Therefore, you may or may not specify the wildcard character at the end of the partial search criteria. However, you have to prefix the wildcard character manually wherever required.

5. Click **OK**.

The approval transaction is removed from the search results.

**Note:**

By default, any modifications will be highlighted in the Yellow (9933FF) color and new additions will be highlighted in the Purple (FFFF66) color. You can easily change these default colors. For more information on how to set the colors used for highlighting, see [Setting the CI\\_AXENTITY Feature Configuration](#) on page 2902.

6. Review the changes and click **Approve** to accept the changes.

The changes in the approval transaction are approved.

**Related Topics**

For more information on...	See...
<b>Search Approval Transaction</b> zone	<a href="#">Search Approval Transaction</a> on page 657
<b>Comparison: New versus Existing</b> screen	<a href="#">Comparison: New versus Existing</a> on page 663
How to search for an approval transaction	<a href="#">Searching for an Approval Transaction</a> on page 662

**Rejecting an Approval Transaction****Prerequisites**

To return an approval transaction to its submitter, you should have:

- Rejection reasons defined in the application

**Note:**

While returning an approval transaction, you need to specify the reason why you want to return the approval transaction. You can select the appropriate rejection reason only when you have defined the reasons for the **Rejected** status of the business object in the **Status Reason** screen.

The system will not allow you to approve, return or revert an approval transaction submitted by you.

**Procedure**

To reject an approval transaction:

1. Click the **Menu** link in the **Application** toolbar.

A list appears.

2. In the **Search Results** section, click the link in the **Approval Transaction ID** column corresponding to the approval transaction which you want to review.

The **Comparison: New versus Existing** screen appears.

3. Review the compared existing and new approval transactions.

4. Click Return to Submitter.” With stepresult, “The Rejection/Cancelation Reason window appears. It contains the following fie

Field Name	Field Description	Mandatory (Yes or No)
Approval Workflow Reason	Used to search a particular approval workflow reason.	Yes
Comments	Used to specify additional information while rejecting the usage record.	Yes



5. Enter the required details.
6. Click **OK**.

The approval transaction is removed from the search results.

### Related Topics

For more information on...	See...
Search Approval Transaction zone	<a href="#">Search Approval Transaction</a> on page 657
Comparison: New versus Existing screen	<a href="#">Comparison: New versus Existing</a> on page 663
How to approve an approval transaction	<a href="#">Approving an Approval Transaction</a> on page 663
How to search for an approval transaction	<a href="#">Searching for an Approval Transaction</a> on page 662

## Canceling an Approval Transaction

### Prerequisites

To revert an approval transaction to its initial status, you should have:

- Cancellation reasons defined in the application

### **Note:**

While reverting an approval transaction, you need to specify the reason why you want to revert the approval transaction. You can select the appropriate cancellation reason only when you have defined the reasons for the **Canceled** status of the business object in the **Status Reason** screen.

The system will not allow you to approve, return or revert an approval transaction submitted by you.

### Procedure

To cancel an approval transaction:

1. Search for approval transactions with task details and status as Approve in the **Approval Transaction** screen.
2. In the **Search Results** section, click the link in the **Approval Transaction ID** column corresponding to the approval transaction which you want to review.

The **Comparison: New versus Existing** screen appears.

3. Review the compared existing and new approval transactions.
4. Click **Revert to Original**.

The **Rejection/Cancellation Reason** window appears. It contains the following fields:

Field Name	Field Description	Mandatory (Yes or No)
Approval Workflow Reason	Used to search a particular approval workflow reason.	Yes
Comments	Used to specify additional information while rejecting the usage record.	Yes

5. Enter the required details.

A **Comparison: New versus Existing** screen appears where you can view the changes in the new transaction as compared to the existing ones.

**Note:**

By default, any modifications will be highlighted in the Yellow (9933FF) color and new additions will be highlighted in the Purple (FFFF66) color. You can easily change these default colors. For more information on how to set the colors used for highlighting, see [Setting the CI\\_AXENTITY Feature Configuration](#) on page 2902.

6. Click **OK**.

The approval transaction is removed from the search results.

**Related Topics**

For more information on...	See...
<b>Search Approval Transaction</b> zone	<a href="#">Search Approval Transaction</a> on page 657
<b>Comparison: New versus Existing</b> screen	<a href="#">Comparison: New versus Existing</a> on page 663
How to approve an approval transaction	<a href="#">Approving an Approval Transaction</a> on page 663
How to search for an approval transaction	<a href="#">Searching for an Approval Transaction</a> on page 662

**Modifying an Approval Transaction****Prerequisites**

To modify an approval transaction, you should have:

- Characteristic Types defined in the application.

**Procedure**

To Modify an approval transaction:

1. Search for approval transactions with task details and status as Modify in the **Approval Transaction** screen.

**Note:** ORMB search engine supports wildcard search, where you can substitute the percentage (%) symbol as a stand in for any word or letter in a search criteria. You can use the '%' wildcard character in all input fields except the date and ID fields. The '%' wildcard character is suffixed automatically at the end of the partial search criteria. Therefore, you may or may not specify the wildcard character at the end of the partial search criteria. However, you have to prefix the wildcard character manually wherever required.

2. From the **Main** menu, select **Approval Workflow Management** and then click **Approval Transaction**.

A screen appears where you can review the changes, and accordingly modify or resolve the request based on your observations. In case where the submitter action is **Update (UPD)**, you will be able to compare the existing and new data, and accordingly take an action.

3. Modify the required details.
4. Click **Save**.

The modifications made to the approval transaction are saved.

**Related Topics**

For more information on...	See...
<b>Approval Transaction</b> screen	<a href="#">Approval Transaction</a> on page 657
<b>Search Approval Transaction</b> zone	<a href="#">Search Approval Transaction</a> on page 657
How to search for an approval transaction	<a href="#">Searching for an Approval Transaction</a> on page 662

## Withdrawing an Approval Transaction

### Procedure

To withdraw an approval transaction:

1. Click the **Menu** link in the **Application** toolbar.

A list appears.

2. In the **Search Results** section, click the link in the **Withdraw** column corresponding to the approval transaction which you want to withdraw.

A message appears confirming whether you want to withdraw the approval transaction.

3. Click **OK**.

A message appears confirming whether you want to delete the approval transaction.

4. Click **OK**.

The approval transaction is deleted.

### Related Topics

For more information on...	See...
<b>Approval Transaction</b> screen	<a href="#">Approval Transaction</a> on page 657
<b>Search Approval Transaction</b> zone	<a href="#">Search Approval Transaction</a> on page 657
How to search for an approval transaction	<a href="#">Searching for an Approval Transaction</a> on page 662

## Resolving an Approval Transaction

### Prerequisites

To resolve an approval transaction, you should have:

- Characteristic Types defined in the application.

### Procedure

To resolve an approval transaction:

1. Search for approval transactions with task details and status as Resolve in the **Approval Transaction** screen.

A list appears.

2. In the **Search Results** section, click the link in the **Approval Transaction ID** column corresponding to the approval transaction which you want to resolve.

A screen appears where you can review the changes, and accordingly modify or resolve the request based on your observations. In case where the submitter action is Update (UPD), you will be able to compare the existing and new data, and accordingly take an action.

3. Make the required changes.

4. Click **Save**.

The changes resolve for the approval transaction are saved.

### Related Topics

For more information on...	See...
<b>Approval Transaction</b> screen	<a href="#">Approval Transaction</a> on page 657

<b>For more information on...</b>	<b>See...</b>
<b>Search Approval Transaction</b> zone	<a href="#">Search Approval Transaction</a> on page 657
How to search for an approval transaction	<a href="#">Searching for an Approval Transaction</a> on page 662

## Approve Price Assignment

The **Approve Price Assignment** screen allows you to search for the price assignment requests that are pending in your workflow for approval. You can review the changes, and accordingly approve, reject or cancel the request based on your observations. It contains the following zones:

- [Search](#) on page 668
- [List of Price Assignments](#) on page 671
- [Approve Price Assignment - Comparison: New versus Existing](#) on page 672
- [Approval Transaction Log](#) on page 661

## Search

The **Search** zone allows you to search for the price assignment requests that are pending in your workflow for approval. It contains the following two sections:

- **Search Criteria** – The **Search Criteria** section contains the following fields:

Field Name	Field Description	Mandatory (Yes or No)
Search By	Used to indicate whether you want to search for price assignments using the account, person, price list, submitter ID or transaction ID. The valid values are: <ul style="list-style-type: none"> <li>• Person</li> <li>• Account</li> <li>• Price List</li> <li>• Submitter ID</li> <li>• Approval Transaction ID</li> </ul> <div style="border: 1px solid black; padding: 2px; margin-top: 5px;"><b>Note:</b> By default, the <b>Person</b> option is selected.</div>	Yes
Division	Used to search price assignments which are associated with a particular division. <div style="border: 1px solid black; padding: 2px; margin-top: 5px;"><b>Note:</b> You can only view those divisions to which you have access in the <b>Division</b> list. This field appears only when you select the <b>Person</b> or <b>Account</b> option from the <b>Search By</b> list.</div>	No

Field Name	Field Description	Mandatory (Yes or No)
Person Identifier Type	Used to specify the value for the person identifier type.	Yes (Conditional)  <b>Note:</b> If you enter the person identifier as a search criteria, you have to select the person identifier type.
Person Identifier	Used to specify the ID linked to the person.  <b>Note:</b> This field appears only when you select the <b>Person</b> option from the <b>Search By</b> list.	Yes (Conditional)  <b>Note:</b> If you specify the person identifier type as a search criteria, you have to enter the person identifier.
Account ID	Used to search price assignments which are created for a particular account.  <b>Note:</b> This field appears only when you select the <b>Account</b> option from the <b>Search By</b> list.	No
Account Identifier Type	Used to select the identifier type based on which you want to search price assignments of an account.  <b>Note:</b> This field appears only when you select the <b>Account</b> option from the <b>Search By</b> list.	Yes (Conditional)  <b>Note:</b> If you enter the account identifier as a search criteria, you have to select the account identifier type.
Account Identifier	Used to specify the account whose price assignments you want to view.  <b>Note:</b> This field appears only when you select the <b>Account</b> option from the <b>Search By</b> list.	Yes (Conditional)  <b>Note:</b> If you specify the account identifier type as a search criteria, you have to enter the account identifier.
Price List Description	Used to search price lists with a particular description.  <b>Note:</b> This field appears only when you select the <b>Price List</b> option from the <b>Search By</b> list.	No
Submitter ID	Used to search for price assignment requests that are created by a particular submitter.  <b>Note:</b> This field appears only when you select the <b>Submitter ID</b> option from the <b>Search By</b> list.	No

Field Name	Field Description	Mandatory (Yes or No)
Approval Transaction ID	<p>This field appears only when you select the <b>Approval Transaction ID</b> option from the <b>Search By</b> list.</p> <div style="border: 1px solid black; padding: 5px;"> <p><b>Note:</b></p> <p>The approval transaction ID is generated automatically when the price assignment request is created.</p> <p>This field appears only when you select the <b>Transaction ID</b> option from the <b>Search By</b> list.</p> </div>	No

**Note:** You must specify at least one search criterion while searching for a price assignment.

- **Search Results** – On clicking the **Search** button, the search results appear based on the specified search criteria. It contains the following columns:

Column Name	Column Description
Account ID	<p>Displays the account ID.</p> <div style="border: 1px solid black; padding: 5px;"> <p><b>Note:</b> This column appears only when you select the <b>Account</b> option from the <b>Search By</b> list.</p> </div>
Account Identifier Type	<p>Indicates the account identifier type of the account for the price assignments.</p> <div style="border: 1px solid black; padding: 5px;"> <p><b>Note:</b> This column appears only when you select the <b>Account</b> option from the <b>Search By</b> list.</p> </div>
Account Identifier	<p>Displays the value of the account identifier type.</p> <div style="border: 1px solid black; padding: 5px;"> <p><b>Note:</b> This column appears only when you select the <b>Account</b> option from the <b>Search By</b> list.</p> </div>
Price List ID	<div style="border: 1px solid black; padding: 5px;"> <p><b>Note:</b> This column appears only when you select the <b>Price List</b> option from the <b>Search By</b> list.</p> </div>
Price List Description	<p>Displays the description for the price list.</p> <div style="border: 1px solid black; padding: 5px;"> <p><b>Note:</b> This column appears only when you select the <b>Price List</b> option from the <b>Search By</b> list.</p> </div>
Person Identifier	<div style="border: 1px solid black; padding: 5px;"> <p><b>Note:</b> This column appears only when you select the <b>Person</b> option from the <b>Search By</b> list.</p> </div>
Person Name	<p>Displays the name of the person.</p> <div style="border: 1px solid black; padding: 5px;"> <p><b>Note:</b> This column appears only when you select the <b>Person</b> option from the <b>Search By</b> list.</p> </div>
Division	<p>Displays the division to which the account, person, or price list belongs.</p>

Column Name	Column Description
Submitter ID	Displays the ID of the submitter.  <b>Note:</b> This column appears only when you select the <b>Submitter ID</b> option from the <b>Search By</b> list.
Approval Transaction ID	Displays the approval transaction ID.  <b>Note:</b> This column appears only when you select the <b>Approval Transaction ID</b> option from the <b>Search By</b> list.

On clicking the **Broadcast**  icon corresponding to the account, person, price list, or submitter ID the **List of Price Assignments** zone appears with the list of price assignments.

### Related Topics

For more information on...	See...
<b>List of Price Assignments</b> zone	<a href="#">List of Price Assignments</a> on page 690
How to approve a price assignment for an account	<a href="#">Approving a Price Assignment for an Account</a> on page 675
How to approve a price assignment for a person	<a href="#">Approving a Price Assignment for a Person</a> on page 676
How to approve a price assignment for a price list	<a href="#">Approving a Price Assignment for a Price List</a> on page 677
How to reject a price assignment for an account	<a href="#">Rejecting a Price Assignment for an Account</a> on page 678
How to reject a price assignment for a person	<a href="#">Rejecting a Price Assignment for a Person</a> on page 679
How to reject a price assignment for a price list	<a href="#">Rejecting a Price Assignment for a Price List</a> on page 681
How to cancel a price assignment for an account	<a href="#">Canceling a Price Assignment for an Account</a> on page 682
How to cancel a price assignment for a person	<a href="#">Canceling a Price Assignment for a Person</a> on page 683
How to cancel a price assignment for a price list	<a href="#">Canceling a Price Assignment for a Price List</a> on page 685

## List of Price Assignments

The **List of Price Assignments** zone lists price assignment requests specific to an account, a person, or a price list. It contains the following columns:

Column Name	Column Description
Approval Transaction ID	Displays the approval transaction id.  <b>Note:</b> The approval transaction id is generated automatically when the price assignment request is created.
Submitter Name	Displays the name of the submitter.
Action	Indicates the type of action, such as <b>Add</b> , <b>Update (UPD)</b> , or <b>Delete (DEL)</b> performed by the submitter during price assignment.
Submitted On	Indicates the submitter who has created the price assignment request.

Column Name	Column Description
To Do Type	Displays the type of To Do (notification) received for the price assignment request.
Price Item	Displays the price item or price item code.
Description	Displays the description of the price item or price item code.
Pricing Currency	Indicates the currency in which the price item pricing is defined.
Start Date	Displays the date from when the price item pricing is effective.
End Date	Displays the date till when the price item pricing is effective.
Approval Transaction Information	Displays the additional information of an approval transaction.

**Note:**

By default, the **List of Price Assignments** zone does not appear in the **Approve Price Assignment** screen. It appears only when you click the **Broadcast**  icon corresponding to the account, person, or price list in the **Search** zone.

**Related Topics**

For more information on...	See...
<b>Search Approve Price Assignment</b> zone	<a href="#">Search</a> on page 668
<b>Comparison: New versus Existing</b> zone	<a href="#">Approve Price Assignment - Comparison: New versus Existing</a> on page 672
How to approve a price assignment for an account	<a href="#">Approving a Price Assignment for an Account</a> on page 675
How to approve a price assignment for a person	<a href="#">Approving a Price Assignment for a Person</a> on page 676
How to approve a price assignment for a price list	<a href="#">Approving a Price Assignment for a Price List</a> on page 677
How to reject a price assignment for an account	<a href="#">Rejecting a Price Assignment for an Account</a> on page 678
How to reject a price assignment for a person	<a href="#">Rejecting a Price Assignment for a Person</a> on page 679
How to reject a price assignment for a price list	<a href="#">Rejecting a Price Assignment for a Price List</a> on page 681
How to cancel a price assignment for an account	<a href="#">Canceling a Price Assignment for an Account</a> on page 682
How to cancel a price assignment for a person	<a href="#">Canceling a Price Assignment for a Person</a> on page 683
How to cancel a price assignment for a price list	<a href="#">Canceling a Price Assignment for a Price List</a> on page 685

**Approve Price Assignment - Comparison: New versus Existing**

The **Comparison: New versus Existing** zone lists the existing and the new price assignments defined in the system. You can approve, cancel, reject a price assignment through this zone. It contains the following fields:

Field Name	Field Description
Approval Transaction ID	Displays the approval transaction id.
Submitter ID	Displays the submitter id who has created the price assignment request.



Field Name	Field Description
Approval Transaction Information	Displays information about the approval transaction
Action	Indicates the action that can be performed on the price assignment. The valid values are: <ul style="list-style-type: none"> <li>• Add – Allows you to define the tiering setup of the price assignment</li> <li>• DEL – Allows you to delete the tiering setup of the price assignment.</li> <li>• UPD – Allows you to upload the tiering setup of the price assignment.</li> </ul>

In addition to the above fields, this zone also contains the following two sections:

- **New** – It consists of the new approved price assignments.
- **Existing** – It consists of the existing or old price assignments.

In addition, this zone also contains the following buttons:

Button Name	Button Description
Approve	Used to approve the price assignment.
Return to Submitter	Used to reject the price assignment.
Revert to Original	Used to cancel the price assignment.

**Note:**

By default, the **Comparison: New versus Existing** zone does not appear in the **Approve Price Assignment** screen. It appears only when you click the **Broadcast**  icon corresponding to the approval transaction ID in the **List Of Price Assignments** zone.

The changes made are highlighted in both the sections for the respective fields. The fields change according to the price assignments.

You can click on **Approve** button, **Return to Submitter** button, or **Revert to Original** button to **Approve**, **Reject** or **Cancel** the price assignments, respectively.

**Related Topics**

For more information on...	See...
Search Approve Price Assignment zone	<a href="#">Search</a> on page 668
List of Price Assignments zone	<a href="#">List of Price Assignments</a> on page 690
How to approve a price assignment for an account	<a href="#">Approving a Price Assignment for an Account</a> on page 675
How to approve a price assignment for a person	<a href="#">Approving a Price Assignment for a Person</a> on page 676
How to approve a price assignment for a price list	<a href="#">Approving a Price Assignment for a Price List</a> on page 677
How to reject a price assignment for an account	<a href="#">Rejecting a Price Assignment for an Account</a> on page 678
How to reject a price assignment for a person	<a href="#">Rejecting a Price Assignment for a Person</a> on page 679

For more information on...	See...
How to reject a price assignment for a price list	<a href="#">Rejecting a Price Assignment for a Price List</a> on page 681
How to cancel a price assignment for an account	<a href="#">Canceling a Price Assignment for an Account</a> on page 682
How to cancel a price assignment for a person	<a href="#">Canceling a Price Assignment for a Person</a> on page 683
How to cancel a price assignment for a price list	<a href="#">Canceling a Price Assignment for a Price List</a> on page 685

## Approval Transaction Log

The **Approval Transaction Log** zone displays the complete trail of submitter and approver actions performed on the approval transaction. It contains the following columns:

Column Name	Column Description
Date Time	Displays the date and time when the action was performed on the approval transaction.
User Name	Indicates the user who has performed the action on the approval transaction.
Status	Indicates the status of the approval transaction. The valid values are: <ul style="list-style-type: none"> <li>• Approved</li> <li>• Cancelled</li> <li>• Rejected</li> <li>• Inprocess</li> <li>• Pending</li> <li>• Initial</li> <li>• Deleted</li> </ul>
Status Reason	Indicates the reason why the approval transaction was rejected or cancelled.
Comments	Displays the additional details entered by the approver on rejecting or cancelling the approval transaction.

### Note:

By default, the **Approval Transaction Log** zone does not appear in the **Approve Price Assignment** screen. It appears only when you click the **Broadcast**  icon corresponding to the approval transaction ID in the **List Of Price Assignments** zone.

You can change the layout of this zone. For more information on how to change the layout, see [Changing the Layout](#) on page 2882.

### Related Topics

For more information on...	See...
<b>List Of Price Assignments</b> zone	<a href="#">List of Price Assignments</a> on page 690

## Approving a Price Assignment for an Account

You can view the number of price assignments which are pending for approval in the **Approve Price Assignment** screen. The approver can review, and accordingly approve, reject or cancel the price assignment based on the observations.



**Note:** The system will not allow you to approve, reject or cancel a price assignment submitted by you.

### Procedure

To approve a price assignment for an account:

1. Click the **Menu** link in the **Application** toolbar.  
A list appears.
2. From the **Main** menu, select **Approval Workflow Management** and then click **Approve Price Assignment**.  
The **Approve Price Assignment** screen appears.
3. Enter the search criteria in the **Search** zone.

**Note:** ORMB search engine supports wildcard search, where you can substitute the percentage (%) symbol as a stand in for any word or letter in a search criteria. You can use the ‘%’ wildcard character in all input fields except the date and ID fields. The ‘%’ wildcard character is suffixed automatically at the end of the partial search criteria. Therefore, you may or may not specify the wildcard character at the end of the partial search criteria. However, you have to prefix the wildcard character manually wherever required.

4. Click **Search**.  
A list of accounts that meet the search criteria appears in the **Search Results** section.
5. Click the **Broadcast**  icon corresponding to the account whose price assignments you want to review for approval.  
The **List of Price Assignments** zone appears.
6. In the **List of Price Assignments** zone, click the **Broadcast**  icon corresponding to the price assignment whose details you want to review and approve.  
The **Comparison: New Versus Existing** zone appears.

### Note:

By default, any modifications will be highlighted in the Yellow (9933FF) color and new additions will be highlighted in the Purple (FFFF66) color. You can easily change these default colors. For more information on how to set the colors used for highlighting, see [Setting the CI\\_AXENTITY Feature Configuration](#) on page 2902.

Only those users who have access to the application services for each business object within the approval workflow group will be able to view the details of the price assignment request.

7. Review the compared existing and new approval transactions.  
A message appears indicating that the price assignment request is sent to the approver at the next level in the hierarchy for approval. However, if you are the last approver in the hierarchy, a message appears indicating that the price assignment request is approved successfully.
8. Click **Approve**.  
A message appears with confirmation on transaction approved successfully.

**Tip:** Alternatively, in the **List of Price Assignments** zone, you can select the check box corresponding to the price assignment request that you want to approve and then click **Approve**.

9. Click **OK**.

The approval transaction is removed from the **List of Price Assignments** zone.

**Related Topics**

For more information on...	See...
<b>Approve Price Assignment</b> screen	<a href="#">Approve Price Assignment</a> on page 668
<b>Search</b> zone	<a href="#">Search</a> on page 668
<b>List of Price Assignments</b> zone	<a href="#">List of Price Assignments</a> on page 671
<b>Comparison: New versus Existing</b> zone	<a href="#">Comparison: New versus Existing</a> on page 663

## Approving a Price Assignment for a Person

### Procedure



To approve a price assignment for a person:

1. Click the **Menu** link in the **Actions/Navigation** area.  
A list appears.
2. From the **Main** menu, select **Approval Workflow Management** and then click **Approve Price Assignment**.  
The **Approve Price Assignment** screen appears.
3. In the **Search** zone, enter the search criteria by selecting **Person** in the **Search By** field.

**Note:**

ORMB search engine supports wildcard search, where you can substitute the percentage (%) symbol as a stand in for any word or letter in a search criteria. You can use the ‘%’ wildcard character in all input fields except the date and ID fields. The ‘%’ wildcard character is suffixed automatically at the end of the partial search criteria. Therefore, you may or may not specify the wildcard character at the end of the partial search criteria. However, you have to prefix the wildcard character manually wherever required.

The **Search Results** appear only when **Person Identifier Type** and **Person Identifier** fields are entered.

4. Click **Search**.  
A list of persons that meet the search criteria appears in the **Search Results** section.
5. Click the **Broadcast**  icon corresponding to the person whose price assignments you want to review for approval.  
The **List of Price Assignments** zone appears.
6. Click the **Broadcast**  icon corresponding to the **Transaction Id** in the **List of Price Assignments** zone, whose details you want to view and approve.  
The **Comparison: New Versus Existing** zone appears.

**Note:**

By default, any modifications will be highlighted in the Yellow (9933FF) color and new additions will be highlighted in the Purple (FFFF66) color. You can easily change these default colors. For more information on how to set the colors used for highlighting, see [Setting the CI\\_AXENTITY Feature Configuration](#) on page 2902.

Only those users who have access to the application services for each business object within the approval workflow group will be able to view the details of the price assignment request.

- Review the pricing details, tiering ranges, and price assignment characteristics, and if they are accurate, then click **Approve**.

A message appears indicating that the price assignment request is sent to the approver at the next level in the hierarchy for approval. However, if you are the last approver in the hierarchy, a message appears indicating that the price assignment request is approved successfully.

- Click **OK**.

A To Do (notification) is sent to the approver at the next level in the hierarchy. You will no longer be able to view this request in your workflow for approval. In case you are the last approver in the hierarchy, the changes are committed to the database.

**Tip:** Alternatively, in the **List of Price Assignments** zone, you can select the check box corresponding to the price assignment request that you want to approve, and then click **Approve**.

### Related Topics

For more information on...	See...
<b>Approve Price Assignment</b> screen	<a href="#">Approve Price Assignment</a> on page 668
<b>Search</b> zone	<a href="#">Search</a> on page 668
<b>List of Price Assignments</b> zone	<a href="#">List of Price Assignments</a> on page 671



## Approving a Price Assignment for a Price List

### Procedure

To approve a price assignment for a price list:

- Click the **Menu** link in the **Application** toolbar.  
A list appears.
- From the **Main** menu, select **Approval Workflow Management** and then click **Approve Price Assignment**.  
The **Approve Price Assignment** screen appears.
- In the **Search** zone, enter the search criteria by selecting either **Price List** in the **Search By** field.

**Note:** ORMB search engine supports wildcard search, where you can substitute the percentage (%) symbol as a stand in for any word or letter in a search criteria. You can use the ‘%’ wildcard character in all input fields except the date and ID fields. The ‘%’ wildcard character is suffixed automatically at the end of the partial search criteria. Therefore, you may or may not specify the wildcard character at the end of the partial search criteria. However, you have to prefix the wildcard character manually wherever required.

- Click **Search**.  
A list of price lists that meet the search criteria appears in the **Search Results** section.
- Click the **Broadcast**  icon corresponding to the price list whose price assignments you want to review for approval.  
The **List of Price Assignments** zone appears.
- Click the **Broadcast**  icon corresponding to the **Transaction Id** in the **List of Price Assignments** zone, whose details you want to view and approve.  
The **Comparison: New Versus Existing** zone appears.
- Review the pricing details, tiering ranges, and price assignment characteristics, and if they are accurate, then click **Approve**.

A message appears indicating that the price assignment request is sent to the approver at the next level in the hierarchy for approval. However, if you are the last approver in the hierarchy, a message appears indicating that the price assignment request is approved successfully.

#### 8. Click **OK**.

A To Do (notification) is sent to the approver at the next level in the hierarchy. You will no longer be able to view this request in your workflow for approval. In case you are the last approver in the hierarchy, the changes are committed to the database.

**Tip:** Alternatively, in the **List of Price Assignments** zone, you can select the check box corresponding to the price assignment request that you want to approve, and then click **Approve**.

#### Related Topics

For more information on...	See...
<b>Approve Price Assignment</b> screen	<a href="#">Approve Price Assignment</a> on page 668
<b>Search</b> zone	<a href="#">Search</a> on page 668
<b>List of Price Assignments</b> zone	<a href="#">List of Price Assignments</a> on page 671



## Rejecting a Price Assignment for an Account

#### Procedure

To reject a price assignment for an account:

1. Click the **Menu** link in the **Application** toolbar.  
A list appears.
2. From the **Main** menu, select **Approval Workflow Management** and then click **Approve Price Assignment**.  
The **Approve Price Assignment** screen appears.
3. In the **Search** zone, enter the search criteria by selecting either **Account** in the **Search By** field.

**Note:** ORMB search engine supports wildcard search, where you can substitute the percentage (%) symbol as a stand in for any word or letter in a search criteria. You can use the ‘%’ wildcard character in all input fields except the date and ID fields. The ‘%’ wildcard character is suffixed automatically at the end of the partial search criteria. Therefore, you may or may not specify the wildcard character at the end of the partial search criteria. However, you have to prefix the wildcard character manually wherever required.

4. Click **Search**.  
A list of accounts that meet the search criteria appears in the **Search Results** section.
5. Click the **Broadcast**  icon corresponding to the account whose price assignments you want to review for approval.  
The **List of Price Assignments** zone appears.
6. Click the **Broadcast**  icon corresponding to the **Transaction Id** in the **List of Price Assignments** zone, whose details you want to view and approve.  
The **Comparison: New Versus Existing** zone appears.

**Note:**

By default, any modifications will be highlighted in the Yellow (9933FF) color and new additions will be highlighted in the Purple (FFFF66) color. You can easily change these default colors. For more information on how to set the colors used for highlighting, see [Setting the CI\\_AXENTITY Feature Configuration](#) on page 2902.

Only those users who have access to the application services for each business object within the approval workflow group will be able to view the details of the price assignment request.

- Review the pricing details, tiering ranges, and price assignment characteristics, and if they are not appropriate, then click **Return to Submitter**.

The **Rejection/Cancellation Reason** screen appears.

**Tip:** Alternatively, in the **List of Price Assignments** zone, you can select the check box corresponding to the price assignment request that you want to reject, and then click **Return to Submitter**.

- Select the reason for rejecting the price assignment request and enter the comments in the respective field.
- Click **OK**.

The **Approve** and **Revert to Original** buttons are disabled. You will no longer be able to view this request in your workflow for approval.

**Related Topics**

For more information on...	See...
<b>Approve Price Assignment</b> screen	<a href="#">Approve Price Assignment</a> on page 668
<b>Search</b> zone	<a href="#">Search</a> on page 668
<b>List of Price Assignments</b> zone	<a href="#">List of Price Assignments</a> on page 671

**Rejecting a Price Assignment for a Person**

You can view the number of price assignments which are pending for approval in the **Approve Price Assignment** screen. You can review, and accordingly approve, reject or cancel the price assignment based on the observations.

**Note:** The system will not allow you to approve, reject or cancel a price assignment submitted by you.

**Procedure**



To reject a price assignment for a person:

- Click the **Menu** link in the **Application** toolbar.  
A list appears.
- From the **Main** menu, select **Approval Workflow Management** and then click **Approve Price Assignment**.  
The **Approve Price Assignment** screen appears.
- Enter the search criteria in the **Search** zone.

**Note:** ORMB search engine supports wildcard search, where you can substitute the percentage (%) symbol as a stand in for any word or letter in a search criteria. You can use the ‘%’ wildcard character in all input fields except the date and ID fields. The ‘%’ wildcard character is suffixed automatically at the end of the partial search criteria. Therefore, you may or may not specify the wildcard character at the end of the partial search criteria. However, you have to prefix the wildcard character manually wherever required.

- Click **Search**.

A list of persons that meet the search criteria appears in the **Search Results** section.

5. Click the **Broadcast**  icon corresponding to the person whose price assignments you want to review.  
The **List of Price Assignments** zone appears.
6. In the **List of Price Assignments** zone, click the **Broadcast**  icon corresponding to the price assignment whose details you want to review.  
The **Comparison: New Versus Existing** zone appears.

**Note:**

By default, any modifications will be highlighted in the Yellow (9933FF) color and new additions will be highlighted in the Purple (FFFF66) color. You can easily change these default colors. For more information on how to set the colors used for highlighting, see [Setting the CI\\_AXENTITY Feature Configuration](#) on page 2902.

Only those users who have access to the application services for each business object within the approval workflow group will be able to view the details of the price assignment request.

7. Review the compared existing and new approval transactions.

The **Rejection/Cancellation Reason** screen appears. It contains following fields:

Field Name	Field Description	Mandatory (Yes or No)
Reason Code	Used to specify the reason why the approval workflow request is rejected.	Yes
Rejection/Cancellation Comment	Used to specify additional information while rejecting/cancelling the approval workflow request.	Yes

**Tip:** Alternatively, in the **List of Price Assignments** zone, you can select the check box corresponding to the price assignment request that you want to reject, and then click **Return to Submitter**.

8. Click **Return to Submitter**.

The **Rejection/Cancellation Reason** screen appears. It contains the following fields:

Field Name	Field Description	Mandatory (Yes or No)
Approval Workflow Reason	Used to search a particular approval workflow reason.	Yes
Comments	Used to add additional comments.	No

9. Enter the required details.

10. Click **OK**.

The approval transaction is removed from the **List of Price Assignments** zone.

**Note:** Alternatively, you can cancel the price assignment by selecting the check box corresponding to the price assignment which you want to cancel and then click the **Revert to Original** button in the **List of Price Assignments** zone.

### **Related Topics**

For more information on...	See...
<b>Approve Price Assignment</b> screen	<a href="#">Approve Price Assignment</a> on page 668
<b>Search</b> zone	<a href="#">Search</a> on page 668
<b>List of Price Assignments</b> zone	<a href="#">List of Price Assignments</a> on page 671



For more information on...	See...
<b>Comparison: New versus Existing</b> zone	<i>Comparison: New versus Existing</i> on page 663

## Rejecting a Price Assignment for a Price List

You can view the number of price assignments which are pending for approval in the **Approve Price Assignment** screen. You can review, and accordingly approve, reject or cancel the price assignment based on the observations.

**Note:** The system will not allow you to approve, reject or cancel a price assignment submitted by you.

### Procedure

To reject a price assignment for a price list:

1. Click the **Menu** link in the **Actions/Navigation** area.

A list appears.

2. From the **Main** menu, select **Approval Workflow Management** and then click **Approve Price Assignment**.

The **Approve Price Assignment** screen appears.

3. Enter the search criteria in the **Search** zone.

**Note:** ORMB search engine supports wildcard search, where you can substitute the percentage (%) symbol as a stand in for any word or letter in a search criteria. You can use the ‘%’ wildcard character in all input fields except the date and ID fields. The ‘%’ wildcard character is suffixed automatically at the end of the partial search criteria. Therefore, you may or may not specify the wildcard character at the end of the partial search criteria. However, you have to prefix the wildcard character manually wherever required.

4. Click **Search**.

A list of price lists that meet the search criteria appears in the **Search Results** section.

5. Click the **Broadcast**  icon corresponding to the price list whose price assignments you want to review.

The **List of Price Assignments** zone appears.

6. In the **List of Price Assignments** zone, click the **Broadcast**  icon corresponding to the price assignment whose details you want to review.

The **Comparison: New Versus Existing** zone appears.

**Note:**

By default, any modifications will be highlighted in the Yellow (9933FF) color and new additions will be highlighted in the Purple (FFFF66) color. You can easily change these default colors. For more information on how to set the colors used for highlighting, see [Setting the CI\\_AXENTITY Feature Configuration](#) on page 2902.

Only those users who have access to the application services for each business object within the approval workflow group will be able to view the details of the price assignment request.

7. Review the compared existing and new approval transactions.

The **Rejection/Cancellation Reason** screen appears.

**Tip:** Alternatively, in the **List of Price Assignments** zone, you can select the check box corresponding to the price assignment request that you want to reject, and then click **Return to Submitter**.

8. Click **Return to Submitter**.

The **Rejection/Cancellation Reason** screen appears. It contains the following fields:

Field Name	Field Description	Mandatory (Yes or No)
Approval Workflow Reason	Used to search a particular approval workflow reason.	Yes
Comments	Used to add additional comments.	No

9. Enter the required details.

The **Approve** and **Revert to Original** buttons are disabled.

10. Click **OK**.

The approval transaction is removed from the **List of Price Assignments** zone.

**Tip:** Alternatively, you can reject the price assignment by selecting the check box corresponding to the price assignment which you want to reject and then click the **Return to Submitter** button in the **List of Price Assignments** zone.

### Related Topics

For more information on...	See...
<b>Approve Price Assignment</b> screen	<a href="#">Approve Price Assignment</a> on page 668
<b>Search</b> zone	<a href="#">Search</a> on page 668
<b>List of Price Assignments</b> zone	<a href="#">List of Price Assignments</a> on page 671
<b>Comparison: New versus Existing</b> zone	<a href="#">Comparison: New versus Existing</a> on page 663

## Canceling a Price Assignment for an Account

You can view the number of price assignments which are pending for approval in the **Approve Price Assignment** screen. You can review, and accordingly approve, reject or cancel the price assignment based on the observations.

**Note:** The system will not allow you to approve, reject or cancel a price assignment submitted by you.

### Procedure

To cancel a price assignment for an account:

1. Click the **Menu** link in the **Application** toolbar.  
A list appears.
2. From the **Main** menu, select **Approval Workflow Management** and then click **Approve Price Assignment**.  
The **Approve Price Assignment** screen appears.
3. Enter the search criteria in the **Search** zone.

**Note:** ORMB search engine supports wildcard search, where you can substitute the percentage (%) symbol as a stand in for any word or letter in a search criteria. You can use the ‘%’ wildcard character in all input fields except the date and ID fields. The ‘%’ wildcard character is suffixed automatically at the end of the partial search criteria. Therefore, you may or may not specify the wildcard character at the end of the partial search criteria. However, you have to prefix the wildcard character manually wherever required.

4. Click **Search**.  
A list of accounts that meet the search criteria appears in the **Search Results** section.
5. Click the **Broadcast**  icon corresponding to the account whose price assignments you want to review.

The **List of Price Assignments** zone appears.

- In the **List of Price Assignments** zone, click the **Broadcast**  icon corresponding to the price assignment whose details you want to review.

The **Comparison: New Versus Existing** zone appears.

**Note:**

By default, any modifications will be highlighted in the Yellow (9933FF) color and new additions will be highlighted in the Purple (FFFF66) color. You can easily change these default colors. For more information on how to set the colors used for highlighting, see [Setting the CI\\_AXENTITY Feature Configuration](#) on page 2902.

Only those users who have access to the application services for each business object within the approval workflow group will be able to view the details of the price assignment request.

- Review the compared existing and new approval transactions.

The **Rejection/Cancelation Reason** screen appears.

**Tip:** Alternatively, in the **List of Price Assignments** zone, you can select the check box corresponding to the price assignment request that you want to reject, and then click **Revert to Original**.

- Click **Revert to Original**.

The **Rejection/Cancelation Reason** screen appears. It contains the following fields:

Field Name	Field Description	Mandatory (Yes or No)
Approval Workflow Reason	Used to search a particular approval workflow reason.	Yes
Comments	Used to add additional comments.	No

- Enter the required details.

- Click **OK**.

The approval transaction is removed from the **List of Price Assignments** zone.

**Tip:** Alternatively, you can cancel the price assignment by selecting the check box corresponding to the price assignment which you want to cancel and then click the **Revert to Original** button in the **List of Price Assignments** zone.

### Related Topics

For more information on...	See...
<b>Approve Price Assignment</b> screen	<a href="#">Approve Price Assignment</a> on page 668
<b>Search</b> zone	<a href="#">Search</a> on page 668
<b>List of Price Assignments</b> zone	<a href="#">List of Price Assignments</a> on page 671
<b>Comparison: New versus Existing</b> zone	<a href="#">Comparison: New versus Existing</a> on page 663

## Canceling a Price Assignment for a Person

You can view the number of price assignments which are pending for approval in the **Approve Price Assignment** screen. You can review, and accordingly approve, reject or cancel the price assignment based on the observations.

**Note:** The system will not allow you to approve, reject or cancel a price assignment submitted by you.

**Procedure**

To cancel a price assignment for a person:

1. Click the **Menu** link in the **Application** toolbar.

A list appears.

2. From the **Main** menu, select **Approval Workflow Management** and then click **Approve Price Assignment**.

The **Approve Price Assignment** screen appears.

3. Enter the search criteria in the **Search** zone.

**Note:** ORMB search engine supports wildcard search, where you can substitute the percentage (%) symbol as a stand in for any word or letter in a search criteria. You can use the '%' wildcard character in all input fields except the date and ID fields. The '%' wildcard character is suffixed automatically at the end of the partial search criteria. Therefore, you may or may not specify the wildcard character at the end of the partial search criteria. However, you have to prefix the wildcard character manually wherever required.

4. Click **Search**.

A list of accounts that meet the search criteria appears in the **Search Results** section.

5. Click the **Broadcast**  icon corresponding to the account whose price assignments you want to review.

The **List of Price Assignments** zone appears.

6. In the **List of Price Assignments** zone, click the

**Broadcast**  icon corresponding to the price assignment whose details you want to review.

The **Comparison: New Versus Existing** zone appears.

**Note:**

By default, any modifications will be highlighted in the Yellow (9933FF) color and new additions will be highlighted in the Purple (FFFF66) color. You can easily change these default colors. For more information on how to set the colors used for highlighting, see [Setting the CI\\_AXENTITY Feature Configuration](#) on page 2902.

Only those users who have access to the application services for each business object within the approval workflow group will be able to view the details of the price assignment request.

7. Review the compared existing and new approval transactions.

The **Rejection/Cancelation Reason** screen appears.

**Tip:** Alternatively, in the **List of Price Assignments** zone, you can select the check box corresponding to the price assignment request that you want to reject, and then click **Revert to Original**.

8. Click **Revert to Original**.

The **Rejection/Cancelation Reason** screen appears. It contains the following fields:

Field Name	Field Description	Mandatory (Yes or No)
Approval Workflow Reason	Used to search a particular approval workflow reason.	Yes
Comments	Used to add additional comments.	No

9. Enter the required details.

10. Click **OK**.

The approval transaction is removed from the **List of Price Assignments** zone.

**Tip:** Alternatively, you can cancel the price assignment by selecting the check box corresponding to the price assignment which you want to cancel and then click the **Revert to Original** button in the **List of Price Assignments** zone.

### Related Topics

For more information on...	See...
<b>Approve Price Assignment</b> screen	<a href="#">Approve Price Assignment</a> on page 668
<b>Search</b> zone	<a href="#">Search</a> on page 668
<b>List of Price Assignments</b> zone	<a href="#">List of Price Assignments</a> on page 671
<b>Comparison: New versus Existing</b> zone	<a href="#">Comparison: New versus Existing</a> on page 663

## Canceling a Price Assignment for a Price List

You can view the number of price assignments which are pending for approval in the **Approve Price Assignment** screen. You can review, and accordingly approve, reject or cancel the price assignment based on the observations.



**Note:** The system will not allow you to approve, reject or cancel a price assignment submitted by you.

### Procedure

To cancel a price assignment for a price list:

1. Click the **Menu** link in the **Application** toolbar.  
A list appears.
2. From the **Main** menu, select **Approval Workflow Management** and then click **Approve Price Assignment**.  
The **Approve Price Assignment** screen appears.
3. Enter the search criteria in the **Search** zone.

**Note:** ORMB search engine supports wildcard search, where you can substitute the percentage (%) symbol as a stand in for any word or letter in a search criteria. You can use the '%' wildcard character in all input fields except the date and ID fields. The '%' wildcard character is suffixed automatically at the end of the partial search criteria. Therefore, you may or may not specify the wildcard character at the end of the partial search criteria. However, you have to prefix the wildcard character manually wherever required.

4. Click **Search**.  
A list of price lists that meet the search criteria appears in the **Search Results** section.
5. Click the **Broadcast**  icon corresponding to the price list whose price assignments you want to review.  
The **List of Price Assignments** zone appears.
6. In the **List of Price Assignments** zone, click the **Broadcast**  icon corresponding to the price assignment whose details you want to review.  
The **Comparison: New Versus Existing** zone appears.
7. Review the compared existing and new approval transactions.  
The **Rejection/Cancellation Reason** screen appears.

**Tip:** Alternatively, in the **List of Price Assignments** zone, you can select the check box corresponding to the price assignment request that you want to cancel, and then click **Revert to Original**.

8. Click **Revert to Original**.

The **Rejection/Cancelation Reason** screen appears. It contains the following fields:

Field Name	Field Description	Mandatory (Yes or No)
Approval Workflow Reason	Used to search a particular approval workflow reason.	Yes
Comments	Used to add additional comments.	No

9. Enter the required details.

10. Click **OK**.

The approval transaction is removed from the **List of Price Assignments** zone.

**Tip:** Alternatively, you can cancel the price assignment by selecting the check box corresponding to the price assignment which you want to cancel and then click the **Revert to Original** button in the **List of Price Assignments** zone.

### Related Topics

For more information on...	See...
<b>Approve Price Assignment</b> screen	<a href="#">Approve Price Assignment</a> on page 668
<b>Search</b> zone	<a href="#">Search</a> on page 668
<b>List of Price Assignments</b> zone	<a href="#">List of Price Assignments</a> on page 671
<b>Comparison: New versus Existing</b> zone	<a href="#">Comparison: New versus Existing</a> on page 663

## Modify Price Assignment

The submitter has the facility to modify or withdraw a price assignment request before the approver at the first level in the hierarchy approves or rejects the request. Once the changes are made, the submitter submits the request for approval.

The **Modify Price Assignment** screen allows you to modify or withdraw a price assignment request. It contains the following zones:

- [Search](#) on page 686
- [List of Price Assignments](#) on page 701

### Search

The **Search** zone allows you to search for the price assignment request using various search criteria. This zone contains the following two sections:

- **Search Criteria** – The **Search Criteria** section contains the following fields:

Field Name	Field Description	Mandatory (Yes or No)
Search By	<p>Used to indicate whether you want to search for price assignments using the account, person, price list, submitter ID or transaction ID. The valid values are:</p> <ul style="list-style-type: none"> <li>• Person</li> <li>• Account</li> <li>• Price List</li> <li>• Submitter ID</li> <li>• Approval Transaction ID</li> </ul> <p><b>Note:</b> By default, the <b>Person</b> option is selected.</p>	Yes
Division	<p>Used to search price assignments which are associated with a particular division.</p> <p><b>Note:</b> You can only view those divisions to which you have access in the <b>Division</b> list. This field appears only when you select the <b>Person</b> or <b>Account</b> option from the <b>Search By</b> list.</p>	No
Person Identifier Type	<p>Used to select the identifier type based on which you want to search price assignments through which the person's record is created or updated in the system.</p> <p><b>Note:</b> This field appears only when you select the <b>Person</b> option from the <b>Search By</b> list.</p>	Yes (Conditional) <b>Note:</b> If you enter the person identifier as a search criteria, you have to select the person identifier type.
Person Identifier	<p>Used to specify the value for the person identifier type.</p>	Yes (Conditional) <b>Note:</b> If you specify the person identifier type as a search criteria, you have to enter the person identifier.
Account ID	<p>Used to search price assignments which are created for a particular account.</p> <p><b>Note:</b> This field appears only when you select the <b>Account</b> option from the <b>Search By</b> list.</p>	No
Account Identifier Type	<p>Used to select the identifier type based on which you want to search price assignments of an account.</p> <p><b>Note:</b> This field appears only when you select the <b>Account</b> option from the <b>Search By</b> list.</p>	Yes (Conditional) <b>Note:</b> If you enter the account identifier as a search criteria, you have to select the account identifier type.

Field Name	Field Description	Mandatory (Yes or No)
Account Identifier	Used to specify the account whose price assignments you want to view.  <b>Note:</b> This field appears only when you select the <b>Account</b> option from the <b>Search By</b> list.	Yes (Conditional)  <b>Note:</b> If you specify the account identifier type as a search criteria, you have to enter the account identifier.
Price List Description	Used to search price lists with a particular description.  <b>Note:</b> This field appears only when you select the <b>Price List</b> option from the <b>Search By</b> list.	No
Submitter ID	Used to search for price assignment requests that are created by a particular submitter.  <b>Note:</b> This field appears only when you select the <b>Submitter ID</b> option from the <b>Search By</b> list.	No
Approval Transaction ID	Used to search the price assignment request using the approval transaction ID.  <b>Note:</b> The approval transaction ID is generated automatically when the price assignment request is created. This field appears only when you select the <b>Approval Transaction ID</b> option from the <b>Search By</b> list.	No

**Note:** You must specify at least one search criterion while searching for a price assignment.

- **Search Results** - On clicking the **Search** button, the search results appear based on the specified search criteria. The **Search Results** section contains the following columns:

Column Name	Column Description
Person Identifier	Indicates the person for whom the price assignment is created.  <b>Note:</b> This column appears only when you select the <b>Person</b> or <b>Submitter ID</b> option from the <b>Search By</b> list.
Person Name	Displays the name of the person.  <b>Note:</b> This column appears only when you select the <b>Person</b> or <b>Submitter ID</b> option from the <b>Search By</b> list.
Person Identifier Type	Displays the person identifier type.  <b>Note:</b> This column appears only when you select the <b>Submitter ID</b> option from the <b>Search By</b> list.
Division	Displays the division to which the account, person, or price list belongs.



Column Name	Column Description
Account Information	<p>Displays information about the account. In addition, this column has a context menu which helps in navigating to other screens in the application.</p> <p><b>Note:</b></p> <p>This column appears only when you select the <b>Account</b> or <b>Submitter ID</b> option from the <b>Search By</b> list.</p> <p>It has a link. On clicking the link, the <b>Account</b> screen appears where you can view the details of the respective account.</p>
Account Identifier Type	<p>Indicates the account identifier type of the account for the price assignments.</p> <p><b>Note:</b> This column appears only when you select the <b>Account</b> or <b>Submitter ID</b> option from the <b>Search By</b> list.</p>
Account Identifier	<p>Displays the value of the account identifier type.</p> <p><b>Note:</b> This column appears only when you select the <b>Account</b> or <b>Submitter ID</b> option from the <b>Search By</b> list.</p>
Price List ID	<p>Displays the price list ID.</p> <p><b>Note:</b> This column appears only when you select the <b>Price List</b> option from the <b>Search By</b> list.</p>
Price List Description	<p>Displays the description for the price list.</p> <p><b>Note:</b> This column appears only when you select the <b>Price List</b> option from the <b>Search By</b> list.</p> <p><b>Note:</b> This column appears only when you are searching for price assignment requests of a price list.</p>
Submitter ID	<p>Displays the ID of the submitter.</p> <p><b>Note:</b> This column appears only when you select the <b>Submitter ID</b> option from the <b>Search By</b> list.</p>

On clicking the **Broadcast**  icon corresponding to the account, person, price list, or submitter ID the **List of Price Assignments** zone appears with the list of price assignments.

### Related Topics

For more information on...	See...
<b>List of Price Assignments</b> zone	<a href="#">List of Price Assignments</a> on page 690
How to modify a price assignment for an account	<a href="#">Modifying a Price Assignment for an Account</a> on page 691
How to modify a price assignment for a person	<a href="#">Modifying a Price Assignment for a Person</a> on page 692
How to modify a price assignment for a price list	<a href="#">Modifying a Price Assignment for a Price List</a> on page 693

For more information on...	See...
How to withdraw a price assignment for an account	<a href="#">Withdrawing a Price Assignment for an Account</a> on page 693
How to withdraw a price assignment for a person	<a href="#">Withdrawing a Price Assignment for a Person</a> on page 694
How to withdraw a price assignment for a price list	<a href="#">Withdrawing a Price Assignment for a Price List</a> on page 695

## List of Price Assignments

The **List of Price Assignments** zone lists price assignment requests specific to an account, a person, or a price list. It contains the following columns:

Column Name	Column Description
Approval Transaction ID	Displays the approval transaction ID.  <b>Note:</b> The approval transaction id is generated automatically when the price assignment request is created.
Submitter Name	Indicates the submitter who has created the price assignment request.
Action	Indicates the type of action, such as <b>Add</b> , <b>Update (UPD)</b> , or <b>Delete (DEL)</b> , performed by the submitter during price assignment.
Submitted On	Displays the date and time when the price assignment request was created by the submitter.
To Do Type	Displays the type of To Do (notification) received for the price assignment request.
Price Item	Displays the price item or price item code.
Description	Displays the description of the price item or price item code.
Pricing Currency	Indicates the currency in which the price item pricing is defined.
Start Date	Displays the date from when the price item pricing is effective.
End Date	Displays the date till when the price item pricing is effective.
Approval Transaction Information	Displays information about the approval transaction.  <b>Note:</b> This information string is generated using the <b>C1-APPTXNINF</b> algorithm.
Modify	It has a link. On clicking the <b>Modify</b> link, the <b>Modify/Resolve Price Assignment</b> screen appears where you can modify the price assignment.
Withdraw	It has a link. On clicking the <b>Withdraw</b> link, you can withdraw and remove the approval transaction from the list of price assignments.
View	It has a link. On clicking the <b>Log</b> link, you can view the approval transaction log details.

By default, the **List of Price Assignments** zone does not appear in the **Modify Price Assignment** screen. It appears only when you click the **Broadcast**  icon corresponding to the account, person, or price list in the **Search** zone.

### Related Topics

For more information on...	See...
<b>Modify Price Assignment Search</b> zone	<a href="#">Search</a> on page 686
How to modify a price assignment for an account	<a href="#">Modifying a Price Assignment for an Account</a> on page 691
How to modify a price assignment for a person	<a href="#">Modifying a Price Assignment for a Person</a> on page 692
How to modify a price assignment for a price list	<a href="#">Modifying a Price Assignment for a Price List</a> on page 693
How to withdraw a price assignment for an account	<a href="#">Withdrawing a Price Assignment for an Account</a> on page 693
How to withdraw a price assignment for a person	<a href="#">Withdrawing a Price Assignment for a Person</a> on page 694
How to withdraw a price assignment for a price list	<a href="#">Withdrawing a Price Assignment for a Price List</a> on page 695

## Modifying a Price Assignment for an Account

You can view the number of price assignments which are pending for modification in the **Modify Price Assignment** screen. The modifier can review, and accordingly modify, withdraw or view log of the price assignment based on the observations.

### Procedure

To modify a price assignment for an account:

1. Click the **Menu** link in the **Application** toolbar.  
A list appears.
2. From the **Main** menu, select **Approval Workflow Management** and then click **Modify Price Assignment**.  
The **Modify Price Assignment** screen appears.
3. Enter the search criteria in the **Search** zone.

**Note:** ORMB search engine supports wildcard search, where you can substitute the percentage (%) symbol as a stand in for any word or letter in a search criteria. You can use the ‘%’ wildcard character in all input fields except the date and ID fields. The ‘%’ wildcard character is suffixed automatically at the end of the partial search criteria. Therefore, you may or may not specify the wildcard character at the end of the partial search criteria. However, you have to prefix the wildcard character manually wherever required.

4. Click **Search**.  
A list of accounts that meet the search criteria appears in the **Search Results** section.
5. Click the **Broadcast**  icon corresponding to the account whose price assignments you want to review.  
The **List of Price Assignments** zone appears.
6. Click the **Modify** link in the **Modify** column corresponding to the price assignment that you want to modify.  
The **Modify/Resolve Price Assignment** screen appears.

**Note:** Only those users who have access to the application services for each business object within the approval workflow group will be able to modify the details of the price assignment request.

7. Make the required changes.
8. Modify the required details.

The changes made to the price assignment are saved.

### Related Topics

For more information on...	See...
<b>Modify Price Assignment</b> screen	<a href="#">Modify Price Assignment</a> on page 686
<b>Search</b> zone	<a href="#">Search</a> on page 686
<b>List of Price Assignments</b> zone	<a href="#">List of Price Assignments</a> on page 690

## Modifying a Price Assignment for a Person

### Procedure

To modify a price assignment for a person:

1. Click the **Menu** link in the **Application** toolbar.  
A list appears.
2. From the **Main** menu, select **Approval Workflow Management** and then click **Modify Price Assignment**.  
The **Modify Price Assignment** screen appears.
3. In the **Search** zone, enter the search criteria, such as the division to which the person belongs or the person identification type and value.

**Note:** ORMB search engine supports wildcard search, where you can substitute the percentage (%) symbol as a stand in for any word or letter in a search criteria. You can use the ‘%’ wildcard character in all input fields except the date and ID fields. The ‘%’ wildcard character is suffixed automatically at the end of the partial search criteria. Therefore, you may or may not specify the wildcard character at the end of the partial search criteria. However, you have to prefix the wildcard character manually wherever required.

4. Click **Search**.  
A list of persons that meet the search criteria appears in the **Search Results** section.
5. Click the **Broadcast**  icon corresponding to the person whose price assignment requests you want to modify.  
The **List of Price Assignments** zone appears.
6. Click the **Modify** link in the **Modify** column corresponding to the price assignment request that you want to modify.  
The **Modify/Resolve Price Assignment** screen appears where you can modify the pricing details, tiering ranges, and price assignment characteristics.

**Note:** Only those users who have access to the application services for each business object within the approval workflow group will be able to modify the details of the price assignment request.

7. Make the required changes.
8. Click **Save**.  
The price assignment for a person is updated.

### Related Topics

For more information on...	See...
<b>Modify Price Assignment</b> screen	<a href="#">Modify Price Assignment</a> on page 686

For more information on...	See...
Search zone	<a href="#">Search</a> on page 686
List of Price Assignments zone	<a href="#">List of Price Assignments</a> on page 690

## Modifying a Price Assignment for a Price List

### Procedure

To modify a price assignment for a price list:

1. Click the **Menu** link in the **Application** toolbar.  
A list appears.
2. From the **Main** menu, select **Approval Workflow Management** and then click **Modify Price Assignment**.  
The **Modify Price Assignment** screen appears.
3. In the **Search** zone, enter the search criteria, such as the description of the price list.

**Note:** ORMB search engine supports wildcard search, where you can substitute the percentage (%) symbol as a stand in for any word or letter in a search criteria. You can use the ‘%’ wildcard character in all input fields except the date and ID fields. The ‘%’ wildcard character is suffixed automatically at the end of the partial search criteria. Therefore, you may or may not specify the wildcard character at the end of the partial search criteria. However, you have to prefix the wildcard character manually wherever required.

4. Click **Search**.  
A list of price lists that meet the search criteria appears in the **Search Results** section.
5. Click the **Broadcast**  icon corresponding to the price list whose price assignment requests you want to *modify*.  
The **List of Price Assignments** zone appears.
6. Click the **Modify** link in the **Modify** column corresponding to the price assignment request that you want *modify*.  
The **Modify/Resolve Price Assignment** screen appears where you can modify the pricing details, tiering ranges, and price assignment characteristics.

**Note:** Only those users who have access to the application services for each business object within the approval workflow group will be able to modify the details of the price assignment request.

7. Make the required changes.
8. Click **Save**.  
The price assignment for a price list is updated.

### Related Topics

For more information on...	See...
Modify Price Assignment screen	<a href="#">Modify Price Assignment</a> on page 686
Search zone	<a href="#">Search</a> on page 686
List of Price Assignments zone	<a href="#">List of Price Assignments</a> on page 690

## Withdrawing a Price Assignment for an Account

**Procedure**

To withdraw a price assignment for an account:

1. Click the **Menu** link in the **Application** toolbar.

A list appears.

2. Do the following:

If you want to...	Then...
Withdraw a price assignment request when it is in the Pending Approval status	From the <b>Main</b> menu, select <b>Approval Workflow Management</b> and then click <b>Modify Price Assignment</b> . The <b>Modify Price Assignment</b> screen appears.
Withdraw a price assignment request when it has been rejected by an approver at any level in the hierarchy	From the <b>Main</b> menu, select <b>Approval Workflow Management</b> and then click <b>Resolve Price Assignment</b> . The <b>Resolve Price Assignment</b> screen appears.

3. In the **Search** zone, enter the search criteria, such as the division to which the account belongs, account ID, or account identifier.

**Note:** ORMB search engine supports wildcard search, where you can substitute the percentage (%) symbol as a stand in for any word or letter in a search criteria. You can use the ‘%’ wildcard character in all input fields except the date and ID fields. The ‘%’ wildcard character is suffixed automatically at the end of the partial search criteria. Therefore, you may or may not specify the wildcard character at the end of the partial search criteria. However, you have to prefix the wildcard character manually wherever required.

4. Click **Search**.

A list of accounts that meet the search criteria appears in the **Search Results** section.

5. Click the **Broadcast**  icon corresponding to the account whose price assignment requests you want to withdraw.

The **List of Price Assignments** zone appears.

**Note:** The system provides you with a facility to view the log of a price assignment request from the **Modify Price Assignment** and **Resolve Price Assignment** screens before withdrawing a request.

6. Click the **Withdraw** link in the **Withdraw** column corresponding to the price assignment request that you want to withdraw.

A message box appears confirming whether you want to delete the price assignment request.

7. Click **OK**.

You will no longer be able to view this request in your workflow.

**Related Topics**

For more information on...	See...
<b>Modify Price Assignment</b> screen	<a href="#">Modify Price Assignment</a> on page 686
<b>Resolve Price Assignment</b> screen	<a href="#">Resolve Price Assignment</a> on page 697

**Withdrawing a Price Assignment for a Person****Procedure**

To withdraw a price assignment for a person:

1. Click the **Menu** link in the **Application** toolbar.

A list appears.

2. Select the **Main** menu and do the following:

If you want to...	Then...
Withdraw a price assignment request when it is in the Pending Approval status	From the <b>Main</b> menu, select <b>Approval Workflow Management</b> and then click <b>Modify Price Assignment</b> . The <b>Modify Price Assignment</b> screen appears.
Withdraw a price assignment request when it has been rejected by an approver at any level in the hierarchy	From the <b>Main</b> menu, select <b>Approval Workflow Management</b> and then click <b>Resolve Price Assignment</b> . The <b>Resolve Price Assignment</b> screen appears.

3. In the **Search** zone, enter the search criteria, such as the division to which the person belongs or the person identification type and value.

**Note:** ORMB search engine supports wildcard search, where you can substitute the percentage (%) symbol as a stand in for any word or letter in a search criteria. You can use the ‘%’ wildcard character in all input fields except the date and ID fields. The ‘%’ wildcard character is suffixed automatically at the end of the partial search criteria. Therefore, you may or may not specify the wildcard character at the end of the partial search criteria. However, you have to prefix the wildcard character manually wherever required.

4. Click **Search**.

A list of persons that meet the search criteria appears in the **Search Results** section.

5. Click the **Broadcast**  icon corresponding to the person whose price assignment requests you want to withdraw.

The **List of Price Assignments** zone appears.

**Note:** The system provides you with a facility to view the log of a price assignment request from the **Modify Price Assignment** and **Resolve Price Assignment** screens before withdrawing a request.

6. Click the **Withdraw** link in the **Withdraw** column corresponding to the price assignment request that you want to withdraw.

A message box appears confirming whether you want to delete the price assignment request.

7. Click **OK**.

You will no longer be able to view this request in your workflow.

### Related Topics

For more information on...	See...
<b>Modify Price Assignment</b> screen	<a href="#">Modify Price Assignment</a> on page 686
<b>Resolve Price Assignment</b> screen	<a href="#">Resolve Price Assignment</a> on page 697

## Withdrawing a Price Assignment for a Price List

### Procedure

To withdraw a price assignment for a price list:

1. Click the **Menu** link in the **Application** toolbar.

A list appears.

2. Do the following:

If you want to...	Then...
Withdraw a price assignment request when it is in the Pending Approval status	From the <b>Main</b> menu, select <b>Approval Workflow Management</b> and then click <b>Modify Price Assignment</b> . The <b>Modify Price Assignment</b> screen appears.
Withdraw a price assignment request when it has been rejected by an approver at any level in the hierarchy	From the <b>Main</b> menu, select <b>Approval Workflow Management</b> and then click <b>Resolve Price Assignment</b> . The <b>Resolve Price Assignment</b> screen appears.

3. In the **Search** zone, enter the search criteria, such as the description of the price list.

**Note:** ORMB search engine supports wildcard search, where you can substitute the percentage (%) symbol as a stand in for any word or letter in a search criteria. You can use the ‘%’ wildcard character in all input fields except the date and ID fields. The ‘%’ wildcard character is suffixed automatically at the end of the partial search criteria. Therefore, you may or may not specify the wildcard character at the end of the partial search criteria. However, you have to prefix the wildcard character manually wherever required.

4. Click **Search**.

A list of price lists that meet the search criteria appears in the **Search Results** section.

5. Click the **Broadcast**  icon corresponding to the price list whose price assignment requests you want to withdraw.

The **List of Price Assignments** zone appears.

**Note:** The system provides you with a facility to view the log of a price assignment request from the **Modify Price Assignment** and **Resolve Price Assignment** screens before withdrawing a request.

6. Click the **Withdraw** link in the **Withdraw** column corresponding to the price assignment request that you want to withdraw.

A message box appears confirming whether you want to delete the price assignment request.

7. Click **OK**.

You will no longer be able to view this request in your workflow.

### **Related Topics**

For more information on...	See...
<b>Modify Price Assignment</b> screen	<a href="#">Modify Price Assignment</a> on page 686
<b>Resolve Price Assignment</b> screen	<a href="#">Resolve Price Assignment</a> on page 697

## **Viewing the Log of an Approval Transaction**

### **Procedure**

To view the log of an approval transaction:

1. Click the **Menu** link in the **Application** toolbar.

A list appears.



- From the **Main** menu, select **Approval Workflow Management** and then click **Modify Price Assignment**.  
The **Modify Price Assignment** screen appears.
- In the **Search** zone, enter the search criteria, such as the description of the price list.

**Note:** ORMB search engine supports wildcard search, where you can substitute the percentage (%) symbol as a stand in for any word or letter in a search criteria. You can use the ‘%’ wildcard character in all input fields except the date and ID fields. The ‘%’ wildcard character is suffixed automatically at the end of the partial search criteria. Therefore, you may or may not specify the wildcard character at the end of the partial search criteria. However, you have to prefix the wildcard character manually wherever required.

- Click **Search**.  
A list of price lists that meet the search criteria appears in the **Search Results** section.
- Click the **Broadcast**  icon corresponding to the price list whose price assignment requests you want to modify.  
The **List of Price Assignments** zone appears.
- Click on **Log** link in the **View** column.  
The **Approval Transaction Log** screen appears.
- View the log of an approval transaction, as required.

#### **Related Topics**

<b>For more information on...</b>	<b>See...</b>
<b>Modify Price Assignment</b> screen	<a href="#">Modify Price Assignment</a> on page 686
<b>Search</b> zone	<a href="#">Search</a> on page 686
<b>Approval Transaction Log</b> zone	<a href="#">Approval Transaction Log</a> on page 661

## **Resolve Price Assignment**

---

If an approver at any level in the hierarchy rejects a price assignment request, a notification is sent to the submitter who has made the changes. The submitter then makes the required corrections based on the approver’s comments, and resubmits the changes for approval. In this case, the approval process starts once again from the beginning, and not from the level at which the request was rejected.

The **Resolve Price Assignment** screen allows you to resolve or withdraw a price assignment request. It consists of the following zones:

- [Search](#) on page 697
- [List of Price Assignments](#) on page 701

### **Search**

The **Search** zone allows you to search for the price assignment requests rejected by approvers and pending for you to resolve. It contains the following two sections:

- Search Criteria** — The **Search Criteria** section contains the following fields:

Field Name	Field Description	Mandatory (Yes or No)
Search By	<p>Used to indicate whether you want to search price assignments using various details. The valid values are:</p> <ul style="list-style-type: none"> <li>• Person</li> <li>• Account</li> <li>• Price List</li> <li>• Submitter ID</li> <li>• Approver Transaction ID</li> </ul> <p><b>Note:</b> By default, the <b>Person</b> option is selected.</p>	Yes
Division	<p>Used to search price assignments which belong to a particular division.</p> <p><b>Note:</b> You can only view those divisions to which you have access in the <b>Division</b> list.</p>	No
Person Identifier Type	<p>Used to specify the identifier type based on which you want to search for price assignment requests of a person.</p> <p><b>Note:</b> This field appears only when you select the <b>Person</b> option from the <b>Search By</b> list.</p>	Yes (Conditional) <b>Note:</b> If you enter the person identifier as a search criteria, you have to select the person identifier type.
Person Identifier	<p>Used to specify the ID linked to the person.</p> <p><b>Note:</b> This field appears only when you select the <b>Person</b> option from the <b>Search By</b> list.</p>	Yes (Conditional) <b>Note:</b> If you specify the person identifier type as a search criteria, you have to enter the person identifier.
Account ID	<p>Used to search for price assignment requests created for an account.</p> <p><b>Note:</b> This field appears only when you select the <b>Account</b> option from the <b>Search By</b> list.</p>	No
Account Identifier Type	<p>Used to specify the account identifier type of the account whose price assignment requests you want to search.</p> <p><b>Note:</b> This field appears only when you select the <b>Account</b> option from the <b>Search By</b> list.</p>	Yes (Conditional) <b>Note:</b> If you enter the account identifier as a search criteria, you have to select the account identifier type.
Account Identifier	<p>Used to specify the value of the account identifier type.</p> <p><b>Note:</b> This field appears only when you select the <b>Account</b> option from the <b>Search By</b> list.</p>	Yes (Conditional) <b>Note:</b> If you specify the account identifier type as a search criteria, you have to enter the account identifier.

Field Name	Field Description	Mandatory (Yes or No)
Price List Description	Used to search for price assignment requests created for a price list.  <b>Note:</b> This field appears only when you select the <b>Price List</b> option from the <b>Search By</b> list.	No
Submitter ID	Used to search for price assignment requests that are created by a particular submitter.  <b>Note:</b> This field appears only when you select the <b>Submitter ID</b> option from the <b>Search By</b> list.	No
Approval Transaction ID	Used to search the price assignment request using the approval transaction ID.  <b>Note:</b> The approval transaction ID is generated automatically when the price assignment request is created.  This field appears only when you select the <b>Approval Transaction ID</b> option from the <b>Search By</b> list.	No

**Note:** You must specify at least one search criterion while searching for a price assignments.

- **Search Results** — On clicking the **Search** button, the search results appear based on the specified search criteria. The **Search Results** section contains the following columns:

Column Name	Column Description
Person Identifier	Displays the ID linked to the person.  <b>Note:</b> This column appears only when you are searching for price assignment requests of a person.
Person Name	Displays the name of the person.  <b>Note:</b> This column appears only when you are searching for price assignment requests of a person.
Division	Displays the division to which the account, person, or price list belongs.
Account Information	Displays information about the account. In addition, this column has a context menu which helps in navigating to other screens in the application.  <b>Note:</b> This column appears only when you are searching for price assignment requests of an account.  It has a link. On clicking the link, the <b>Account</b> screen appears where you can view the details of the respective account.

Column Name	Column Description
Account Identifier Type	Displays the account identifier type. <b>Note:</b> This column appears only when you are searching for price assignment requests of an account.
Account Identifier	Displays the value of the account identifier type. <b>Note:</b> This column appears only when you are searching for price assignment requests of an account.
Price List ID	Displays the price list ID. <b>Note:</b> This column appears only when you are searching for price assignment requests of a price list.
Price List Description	Displays the description of the price list. <b>Note:</b> This column appears only when you are searching for price assignment requests of a price list.
Owner ID	Displays the ID of the person for whose account the approval workflow request is created.
Approval Transaction ID	Displays the approval transaction ID. <b>Note:</b> The approval transaction ID is generated automatically when the price assignment request is created.
Person Identifier Type	Displays the person identifier type. <b>Note:</b> This column appears only when you are searching for price assignment requests of a person.

On clicking the **Broadcast**  icon corresponding to the account, person, or price list, the **List of Price Assignments** zone appears.

### Related Topics

For more information on...	See...
How to resolve a price assignment for an account	<a href="#">Resolving a Price Assignment for an Account</a> on page 702
How to resolve a price assignment for a person	<a href="#">Resolving a Price Assignment for a Person</a> on page 703
How to resolve a price assignment for a price list	<a href="#">Resolving a Price Assignment for a Price List</a> on page 704
How to withdraw a price assignment for an account	<a href="#">Withdrawing a Price Assignment for an Account</a> on page 704
How to withdraw a price assignment for a person	<a href="#">Withdrawing a Price Assignment for a Person</a> on page 705
How to withdraw a price assignment for a price list	<a href="#">Withdrawing a Price Assignment for a Price List</a> on page 706

## List of Price Assignments

The **List of Price Assignments** zone lists price assignment requests specific to an account, a person, or a price list. It contains the following columns:

Column Name	Column Description
Approval Transaction ID	Displays the approval transaction ID.  <b>Note:</b> The approval transaction ID is generated automatically when the price assignment request is created.
Submitter Name	Indicates the submitter who has created the price assignment request.
Action	Indicates the type of action, such as <b>Add</b> , <b>Update (UPD)</b> , or <b>Delete (DEL)</b> performed by the submitter during price assignment.
Submitted On	Displays the date and time when the price assignment request was created by the submitter.
To Do Type	Displays the type of To Do (notification) received for the price assignment request.
Price Item	Displays the price item code.
Description	Displays the description of the product.
Pricing Currency	Indicates the currency in which the product pricing is defined.
Start Date	Displays the date from when the product pricing is effective.
End Date	Displays the date till when the product pricing is effective.
Approver Name	Indicates the approver who has rejected the price assignment request.
Rejected On	Displays the date and time when the price assignment request was rejected by an approver.
Reject Reason	Indicates the reason why the price assignment request was rejected.
Rejection Comments	Displays the additional details entered by an approver on rejecting the price assignment request.
Approval Transaction Information	Displays information about the approval transaction.  <b>Note:</b> This information string is generated using the <b>C1-APPTXNINF</b> algorithm.
Resolve	On clicking the <b>Resolve</b> link, you can modify the details of the price assignment request, and resubmit it for approval. On resubmitting, the approval workflow process starts once again from the first level in the hierarchy.
Withdraw	On clicking the <b>Withdraw</b> link, you can withdraw the price assignment request. Once you withdraw the request, no further action will be taken on the request.
View	On clicking the <b>Log</b> link, you can view the log of the price assignment request from the <b>Resolve Price Assignment</b> screen before resolving or withdrawing a request.

By default, the **List of Price Assignments** zone does not appear in the **Resolve Price Assignment** screen. It appears only when you click the **Broadcast**  icon corresponding to the account, person, or price list in the **Search** zone.

### Related Topics

For more information on...	See...
How to resolve a price assignment for an account	<a href="#">Resolving a Price Assignment for an Account</a> on page 702
How to resolve a price assignment for a person	<a href="#">Resolving a Price Assignment for a Person</a> on page 703
How to resolve a price assignment for a price list	<a href="#">Resolving a Price Assignment for a Price List</a> on page 704
How to withdraw a price assignment for an account	<a href="#">Withdrawing a Price Assignment for an Account</a> on page 704
How to withdraw a price assignment for a person	<a href="#">Withdrawing a Price Assignment for a Person</a> on page 705
How to withdraw a price assignment for a price list	<a href="#">Withdrawing a Price Assignment for a Price List</a> on page 706

## Resolving a Price Assignment for an Account

### Procedure

To resolve a price assignment for an account:

1. Click the **Menu** link in the **Application** toolbar.  
A list appears.
2. From the **Main** menu, select **Approval Workflow Management** and then click **Resolve Price Assignment**.  
The **Resolve Price Assignment** screen appears.
3. In the **Search** zone, enter the search criteria, such as the division to which the account belongs, account ID, or account identifier.

**Note:** ORMB search engine supports wildcard search, where you can substitute the percentage (%) symbol as a stand in for any word or letter in a search criteria. You can use the ‘%’ wildcard character in all input fields except the date and ID fields. The ‘%’ wildcard character is suffixed automatically at the end of the partial search criteria. Therefore, you may or may not specify the wildcard character at the end of the partial search criteria. However, you have to prefix the wildcard character manually wherever required.

4. Click **Search**.  
A list of accounts that meet the search criteria appears in the **Search Results** section.
5. Click the **Broadcast**  icon corresponding to the account whose price assignment requests you want to resolve.  
The **List of Price Assignments** zone appears.
6. Click the **Resolve** link in the **Resolve** column corresponding to the price assignment request that you want to resolve.  
The **Modify/Resolve Price Assignment** screen appears where you can modify the pricing details, tiering ranges, and price assignment characteristics.

**Note:** Only those users who have access to the application services for each business object within the approval workflow group will be able to resolve the request and resubmit it for approval.

7. Make the required changes.
8. Click **Save**.  
The price assignment is updated and resubmitted for approval.

### Related Topics

For more information on...	See...
<b>Resolve Price Assignment</b> screen	<a href="#">Resolve Price Assignment</a> on page 697
<b>Search</b> zone	<a href="#">Search</a> on page 697
<b>List of Price Assignments</b> zone	<a href="#">List of Price Assignments</a> on page 701

## Resolving a Price Assignment for a Person

### Procedure

To resolve a price assignment for a person:

1. Click the **Menu** link in the **Application** toolbar.  
A list appears.
2. From the **Main** menu, select **Approval Workflow Management** and then click **Resolve Price Assignment**.  
The **Resolve Price Assignment** screen appears.
3. In the **Search** zone, enter the search criteria, such as the division to which the person belongs or the person identification type and value.

**Note:** ORMB search engine supports wildcard search, where you can substitute the percentage (%) symbol as a stand in for any word or letter in a search criteria. You can use the ‘%’ wildcard character in all input fields except the date and ID fields. The ‘%’ wildcard character is suffixed automatically at the end of the partial search criteria. Therefore, you may or may not specify the wildcard character at the end of the partial search criteria. However, you have to prefix the wildcard character manually wherever required.

4. Click **Search**.  
A list of persons that meet the search criteria appears in the **Search Results** section.
5. Click the **Broadcast**  icon corresponding to the person whose price assignment requests you want to resolve.  
The **List of Price Assignments** zone appears.
6. Click the **Resolve** link in the **Resolve** column corresponding to the price assignment request that you want to resolve.

A screen appears where you can modify the pricing details, tiering ranges, and price assignment characteristics.

**Note:** Only those users who have access to the application services for each business object within the approval workflow group will be able to resolve the request, and resubmit it for approval.

7. Make the required changes.
8. Click **Save**.  
The price assignment is updated and resubmitted for approval.

### Related Topics

For more information on...	See...
<b>Resolve Price Assignment</b> screen	<a href="#">Resolve Price Assignment</a> on page 697
<b>Search</b> zone	<a href="#">Search</a> on page 697
<b>List of Price Assignments</b> zone	<a href="#">List of Price Assignments</a> on page 701

## Resolving a Price Assignment for a Price List

### Procedure

To resolve a price assignment for a price list:

1. Click the **Menu** link in the **Application** toolbar.  
A list appears.
2. From the **Main** menu, select **Approval Workflow Management** and then click **Resolve Price Assignment**.  
The **Resolve Price Assignment** screen appears.
3. In the **Search** zone, enter the search criteria, such as the description of the price list.

**Note:** ORMB search engine supports wildcard search, where you can substitute the percentage (%) symbol as a stand in for any word or letter in a search criteria. You can use the ‘%’ wildcard character in all input fields except the date and ID fields. The ‘%’ wildcard character is suffixed automatically at the end of the partial search criteria. Therefore, you may or may not specify the wildcard character at the end of the partial search criteria. However, you have to prefix the wildcard character manually wherever required.

4. Click **Search**.  
A list of price lists that meet the search criteria appears in the **Search Results** section.
5. Click the **Broadcast**  icon corresponding to the price list whose price assignment requests you want to resolve.  
The **List of Price Assignments** zone appears.
6. Click the **Resolve** link in the **Resolve** column corresponding to the price assignment request that you want to resolve.  
The **Modify/Resolve Price Assignment** screen appears where you can modify the pricing details, tiering ranges, and price assignment characteristics.

**Note:** Only those users who have access to the application services for each business object within the approval workflow group will be able to resolve the request, and resubmit it for approval.

7. Make the required changes.
8. Click **Save**.  
The price assignment is updated and resubmitted for approval.

### Related Topics

For more information on...	See...
<b>Resolve Price Assignment</b> screen	<a href="#">Resolve Price Assignment</a> on page 697
<b>Search</b> zone	<a href="#">Search</a> on page 697
<b>List of Price Assignments</b> zone	<a href="#">List of Price Assignments</a> on page 701

## Withdrawing a Price Assignment for an Account

### Procedure

To withdraw a price assignment for an account:

1. Click the **Menu** link in the **Application** toolbar.



A list appears.

- Do the following:

If you want to...	Then...
Withdraw a price assignment request when it is in the Pending Approval status	From the <b>Main</b> menu, select <b>Approval Workflow Management</b> and then click <b>Modify Price Assignment</b> . The <b>Modify Price Assignment</b> screen appears.
Withdraw a price assignment request when it has been rejected by an approver at any level in the hierarchy	From the <b>Main</b> menu, select <b>Approval Workflow Management</b> and then click <b>Resolve Price Assignment</b> . The <b>Resolve Price Assignment</b> screen appears.

- In the **Search** zone, enter the search criteria, such as the division to which the account belongs, account ID, or account identifier.

**Note:** ORMB search engine supports wildcard search, where you can substitute the percentage (%) symbol as a stand in for any word or letter in a search criteria. You can use the ‘%’ wildcard character in all input fields except the date and ID fields. The ‘%’ wildcard character is suffixed automatically at the end of the partial search criteria. Therefore, you may or may not specify the wildcard character at the end of the partial search criteria. However, you have to prefix the wildcard character manually wherever required.

- Click **Search**.

A list of accounts that meet the search criteria appears in the **Search Results** section.

- Click the **Broadcast**  icon corresponding to the account whose price assignment requests you want to withdraw.

The **List of Price Assignments** zone appears.

**Note:** The system provides you with a facility to view the log of a price assignment request from the **Modify Price Assignment** and **Resolve Price Assignment** screens before withdrawing a request.

- Click the **Withdraw** link in the **Withdraw** column corresponding to the price assignment request that you want to withdraw.

A message box appears confirming whether you want to delete the price assignment request.

- Click **OK**.

You will no longer be able to view this request in your workflow.

### Related Topics

For more information on...	See...
<b>Modify Price Assignment</b> screen	<a href="#">Modify Price Assignment</a> on page 686
<b>Resolve Price Assignment</b> screen	<a href="#">Resolve Price Assignment</a> on page 697

## Withdrawing a Price Assignment for a Person

### Procedure

To withdraw a price assignment for a person:

- Click the **Menu** link in the **Application** toolbar.

A list appears.

2. Select the **Main** menu and do the following:

If you want to...	Then...
Withdraw a price assignment request when it is in the Pending Approval status	From the <b>Main</b> menu, select <b>Approval Workflow Management</b> and then click <b>Modify Price Assignment</b> . The <b>Modify Price Assignment</b> screen appears.
Withdraw a price assignment request when it has been rejected by an approver at any level in the hierarchy	From the <b>Main</b> menu, select <b>Approval Workflow Management</b> and then click <b>Resolve Price Assignment</b> . The <b>Resolve Price Assignment</b> screen appears.

3. In the **Search** zone, enter the search criteria, such as the division to which the person belongs or the person identification type and value.

**Note:** ORMB search engine supports wildcard search, where you can substitute the percentage (%) symbol as a stand in for any word or letter in a search criteria. You can use the ‘%’ wildcard character in all input fields except the date and ID fields. The ‘%’ wildcard character is suffixed automatically at the end of the partial search criteria. Therefore, you may or may not specify the wildcard character at the end of the partial search criteria. However, you have to prefix the wildcard character manually wherever required.

4. Click **Search**.

A list of persons that meet the search criteria appears in the **Search Results** section.

5. Click the **Broadcast**  icon corresponding to the person whose price assignment requests you want to withdraw.

The **List of Price Assignments** zone appears.

**Note:** The system provides you with a facility to view the log of a price assignment request from the **Modify Price Assignment** and **Resolve Price Assignment** screens before withdrawing a request.

6. Click the **Withdraw** link in the **Withdraw** column corresponding to the price assignment request that you want to withdraw.

A message box appears confirming whether you want to delete the price assignment request.

7. Click **OK**.

You will no longer be able to view this request in your workflow.

### Related Topics

For more information on...	See...
<b>Modify Price Assignment</b> screen	<a href="#">Modify Price Assignment</a> on page 686
<b>Resolve Price Assignment</b> screen	<a href="#">Resolve Price Assignment</a> on page 697

## Withdrawing a Price Assignment for a Price List

### Procedure

To withdraw a price assignment for a price list:

1. Click the **Menu** link in the **Application** toolbar.

A list appears.

2. Do the following:

If you want to...	Then...
Withdraw a price assignment request when it is in the Pending Approval status	From the <b>Main</b> menu, select <b>Approval Workflow Management</b> and then click <b>Modify Price Assignment</b> . The <b>Modify Price Assignment</b> screen appears.
Withdraw a price assignment request when it has been rejected by an approver at any level in the hierarchy	From the <b>Main</b> menu, select <b>Approval Workflow Management</b> and then click <b>Resolve Price Assignment</b> . The <b>Resolve Price Assignment</b> screen appears.

- In the **Search** zone, enter the search criteria, such as the description of the price list.

**Note:** ORMB search engine supports wildcard search, where you can substitute the percentage (%) symbol as a stand in for any word or letter in a search criteria. You can use the ‘%’ wildcard character in all input fields except the date and ID fields. The ‘%’ wildcard character is suffixed automatically at the end of the partial search criteria. Therefore, you may or may not specify the wildcard character at the end of the partial search criteria. However, you have to prefix the wildcard character manually wherever required.

- Click **Search**.

A list of price lists that meet the search criteria appears in the **Search Results** section.

- Click the **Broadcast**  icon corresponding to the price list whose price assignment requests you want to withdraw.

The **List of Price Assignments** zone appears.

**Note:** The system provides you with a facility to view the log of a price assignment request from the **Modify Price Assignment** and **Resolve Price Assignment** screens before withdrawing a request.

- Click the **Withdraw** link in the **Withdraw** column corresponding to the price assignment request that you want to withdraw.

A message box appears confirming whether you want to delete the price assignment request.

- Click **OK**.

You will no longer be able to view this request in your workflow.

### **Related Topics**

For more information on...	See...
<b>Modify Price Assignment</b> screen	<a href="#">Modify Price Assignment</a> on page 686
<b>Resolve Price Assignment</b> screen	<a href="#">Resolve Price Assignment</a> on page 697

## Viewing the Log of an Approval Transaction

### **Procedure**

To view the log of an approval transaction:

- Click the **Menu** link in the **Application** toolbar.  
A list appears.
- From the **Main** menu, select **Approval Workflow Management** and then click **Modify Price Assignment**.  
The **Resolve Price Assignment** screen appears.

- In the **Search** zone, enter the search criteria, such as the description of the price list.

**Note:** ORMB search engine supports wildcard search, where you can substitute the percentage (%) symbol as a stand in for any word or letter in a search criteria. You can use the ‘%’ wildcard character in all input fields except the date and ID fields. The ‘%’ wildcard character is suffixed automatically at the end of the partial search criteria. Therefore, you may or may not specify the wildcard character at the end of the partial search criteria. However, you have to prefix the wildcard character manually wherever required.

- Click **Search**.

A list of price lists that meet the search criteria appears in the **Search Results** section.

- Click the **Broadcast**  icon corresponding to the price list whose price assignment requests you want to modify.

The **List of Price Assignments** zone appears.

- Click on **Log** link in the **View** column.

The **Approval Transaction Log** screen appears.

- You can view the log of an approval transaction, as required.

#### Related Topics

For more information on...	See...
<b>Approval Transaction</b> screen	<a href="#">Approval Transaction</a> on page 657
<b>Search</b> zone	<a href="#">Search</a> on page 697
<b>Approval Transaction Log</b> zone	<a href="#">Approval Transaction Log</a> on page 661

## Approval Workflow Group (Used for Searching)

The **Approval Workflow Group** screen allows you to search for approval workflow group using various search criteria. Through this screen, you can navigate to the following screen:

- [Approval Workflow Group \(Used for Viewing\)](#) on page 717

This screen consists of the following zone:

- [Search Approval Workflow Group](#) on page 708

For more information on...	See...
How to search an approval workflow group	<a href="#">Searching for an Approval Workflow Group</a> on page 709
How to view the details of approval workflow group	<a href="#">Viewing the Approval Workflow Group Details</a> on page 710

## Search Approval Workflow Group

The **Search Approval Workflow Group** zone allows you to search for an approval workflow group using various search criteria. It contains the following sections:

- Search Criteria** - The **Search Criteria** section contains the following fields:

Field Name	Field Description	Mandatory (Yes or No)
Approval Workflow Group	Used to search a particular approval workflow group.	No
Description	Used to search approval workflow groups with a particular description.	No

- **Search Results** - On clicking the **Search** button, the search results appear based on the specified search criteria. The **Search Results** section contains the following columns:

Column Name	Column Description
Approval Workflow Group	Displays the approval workflow group.
Description	Displays the description of the approval workflow group. <b>Note:</b> It has a link. On clicking the link, the <b>Approval Workflow Group</b> screen appears where you can view the details of the respective approval workflow group.

**Note:** You must specify at least one search criterion while searching for an Approval Workflow Group.

### Related Topics

For more information on...	See...
How to search for an approval workflow group	<a href="#">Searching for an Approval Workflow Group</a> on page 709
How to view the details of an approval workflow group	<a href="#">Viewing the Approval Workflow Group Details</a> on page 710

## Searching for an Approval Workflow Group

### Procedure

To search for an approval workflow group:

1. Click the **Admin** link in the **Application** toolbar.  
A list appears.
2. From the **Admin** menu, select **A** and then click **Approval Workflow Group**.  
The **Approval Workflow Group** screen appears.
3. Enter the search criteria in the **Search Approval Workflow Group** zone.

**Note:** ORMB search engine supports wildcard search, where you can substitute the percentage (%) symbol as a stand in for any word or letter in a search criteria. You can use the '%' wildcard character in all input fields except the date and ID fields. The '%' wildcard character is suffixed automatically at the end of the partial search criteria. Therefore, you may or may not specify the wildcard character at the end of the partial search criteria. However, you have to prefix the wildcard character manually wherever required.

4. Click **Search**.

A list of approval workflow groups that meet the search criteria appear in the **Search Results** section.

### Related Topics

For more information on...	See...
Search Approval Workflow Group screen	<a href="#">Approval Workflow Group (Used for Searching)</a> on page 708
Search Approval Workflow Group zone	<a href="#">Search Approval Workflow Group</a> on page 708

## Viewing the Approval Workflow Group Details

### Procedure

To view the details of an approval workflow group:

1. Search for the approval workflow group in the **Approval Workflow Group** screen.
2. In the **Search Results** section, click the link in the **Description** column corresponding to the approval workflow group whose details you want to view.

The **Approval Workflow Group** screen appears. It consists of the **Main** tab with the following zone:

- [Approval Workflow Group](#) on page 718

3. View the details of the approval workflow group in the **Approval Workflow Group** zone.

### Related Topics

For more information on...	See...
How to search for an approval workflow group	<a href="#">Searching for an Approval Workflow Group</a> on page 709
Approval Workflow Group screen	<a href="#">Approval Workflow Group (Used for Searching)</a> on page 708
Approval Workflow Group zone	<a href="#">Search Approval Workflow Group</a> on page 708

## Defining an Approval Workflow Group

### Prerequisites

To define an approval workflow group, you should have:

- Input and Display UI maps created in the application in case you want to use custom UI maps.
- Dependency, Approval, and Approval Post Processing algorithms defined in the application in case you want to use any of them.

**Note:** Before you define an approval workflow group for the User BO, you need to attach the **C1-APPTXNBAS** algorithm on the **Audit** algorithm spot of the business object belonging to the USER-SC MO, and not the USER MO.

### Procedure



To define an approval workflow group:



1. Click the **Admin** link in the **Application** toolbar.  
A list appears.
2. From the **Admin** menu, Select **A** and then click **Approval Workflow Group**.  
The **Approval Workflow Group** screen appears.
3. Click the **Add** button in the **Page Title** area of **Approval Workflow Group** screen.

The **Approval Workflow Group** screen appears. It contains the following sections:



- **Main** - Used to specify basic details about the approval workflow group.
- **Business Objects and Group BO Relation** - Used to add business objects and define group BO Relation for the approval workflow group.

The **Main** section contains the following:

Field Name	Field Description	Mandatory (Yes or No)
Approval Transaction Type	Used to indicate the transaction type to which the approval workflow group belongs.	Yes
Approval Workflow Group	Used to specify the approval workflow group.	Yes
Description	Used to specify the approval workflow group with a particular description.	Yes
Display UI Map	<p>Used to specify the UI map that you want to use for viewing data of the business objects within the approval workflow group.</p> <p><b>Note:</b> You can search for a UI map, code, and an algorithm by clicking the <b>Search</b> icon () corresponding to the Display UI Map field.</p> <p><b>Note:</b> If you clear the <b>Display UI Map</b> field, you need to either manually specify the UI map or automatically regenerate the UI map by clicking the <b>Regenerate UI Maps</b> icon corresponding to the group in the <b>Approval Workflow Settings</b> screen.</p>	No
Input UI Map	<p>Used to specify the UI map that you want to use for modifying data of the business objects within the approval workflow group.</p> <p><b>Note:</b> You can search for a UI map, code, and an algorithm by clicking the <b>Search</b> icon () corresponding to the Input UI Map field.</p> <p><b>Note:</b> If you clear the <b>Input UI Map</b> field, you need to either manually specify the UI map or automatically regenerate the UI map by clicking the <b>Regenerate UI Maps</b> icon corresponding to the group in the <b>Approval Workflow Settings</b> screen.</p>	No
Dependency Algorithm	<p>Used to specify the algorithm that will be triggered before creating the approval workflow group.</p> <p><b>Note:</b> You can search for a Input UI map, code, and an algorithm by clicking the <b>Search</b> icon () corresponding to the Dependency Algorithm field.</p> <p><b>Note:</b> This algorithm can be used to check all prerequisites before creating the approval workflow group.</p>	No

Field Name	Field Description	Mandatory (Yes or No)
Approval Algorithm	<p>Used to specify the algorithm that will be triggered after the approval workflow group is approved by the approver at the last level in the hierarchy. The following approval algorithms are shipped with ORMB:</p> <ul style="list-style-type: none"> <li>• <b>C1-APPPROD</b> - This approval algorithm is used for the C1PRODUCT group, which is shipped with ORMB.</li> <li>• <b>C1-APPPL</b> - This approval algorithm is used for the C1PRICELST group, which is shipped with ORMB.</li> <li>• <b>C1-APPASG</b> - This approval algorithm is used for the C1PRICEASG group, which is shipped with ORMB.</li> <li>• <b>C1-APPALG</b> - This is a standard approval algorithm that you can use for approval workflow groups where custom logic is not required.</li> </ul> <p>You can also create your own approval algorithms for custom UIs.</p> <div style="border: 1px solid black; padding: 5px; margin-top: 10px;"> <p><b>Note:</b> You can search for a Input UI map, code, and an algorithm by clicking the <b>Search</b> icon  corresponding to the Approval Algorithm field.</p> </div>	No
Approval Post Processing Algorithm	<p>Used to specify the algorithm that will be triggered after the changes (which are approved by all approvers' in the hierarchy) are committed to the database.</p> <div style="border: 1px solid black; padding: 5px; margin-top: 10px;"> <p><b>Note:</b> You can search for a Input UI map, code, and an algorithm by clicking the <b>Search</b> icon  corresponding to the Approval Post Processing Algorithm field.</p> </div>	No



Field Name	Field Description	Mandatory (Yes or No)
Transaction Creation Algorithm	<p>Used to specify the algorithm that will create approval workflow group. The following transaction creation algorithms are shipped with ORMB:</p> <ul style="list-style-type: none"> <li>• <b>C1-APPASGCR</b> - Used to create approval workflow group for price assignment.</li> <li>• <b>C1-AXPROD</b> - Used to create approval workflow group for price item.</li> <li>• <b>C1-AXUSR</b> - Used to create approval workflow group for user.</li> <li>• <b>C1-IGCREATE</b> - Used to create approval workflow group for invoicing group.</li> <li>• <b>C1-AXCREATE</b> - This is a standard transaction creation algorithm that you can use to create approval workflow group for most of the base objects.</li> </ul> <p>You can also create your own transaction creation algorithms for custom UIs.</p> <p>In case of the base UIs, this algorithm is only used while modifying or resolving a group. The initial approval transaction creation for base UIs takes place through the Audit algorithm attached on the business object.</p> <div style="border: 1px solid black; padding: 5px; margin-top: 10px;"> <p><b>Note:</b> You can search for a Input UI map, code, and an algorithm by clicking the <b>Search</b> icon  corresponding to the Transaction Creation Algorithm field.</p> </div>	Yes
Data Retrieval Algorithm	<p>Used to specify the algorithm that will be triggered to retrieve the original data of the business objects within the approval workflow group. This will help an approver to compare the original and new data in case where the submitter action is Update (UPD). The following data retrieval algorithms are shipped with ORMB:</p> <ul style="list-style-type: none"> <li>• <b>C1-APPIGDR</b> - Used to retrieve data for invoicing group.</li> <li>• <b>C1-AXPRICEOV</b> - Used to retrieve data for price assignment.</li> <li>• <b>C1_APPDATA</b> - This is a standard data retrieval algorithm that you can use to retrieve data for most of the base objects.</li> </ul> <p>You can also create your own data retrieval algorithms for custom UIs.</p> <div style="border: 1px solid black; padding: 5px; margin-top: 10px;"> <p><b>Note:</b> You can search for a Input UI map, code, and an algorithm by clicking the <b>Search</b> icon  corresponding to the Data Retrieval Algorithm field.</p> </div>	Yes

Field Name	Field Description	Mandatory (Yes or No)
Information Algorithm	Used to specify the algorithm information.  <b>Note:</b> You can search for a Input UI map, code, and an algorithm by clicking the <b>Search</b> icon (🔍) corresponding to the Approval Post Processing Algorithm field.	No
Compare Map	Used to specify the customized Display UI map that you want to use for the approval workflow group. It overrides the UI map specified in the <b>Display UI Map</b> field.  <b>Note:</b> You can search for a Input UI map, code, and an algorithm by clicking the <b>Search</b> icon (🔍) corresponding to the Approval Post Processing Algorithm field.	No
Input Script	Used to specify the customized Input UI map that you want to use for the approval workflow group. It overrides the UI map specified in the <b>Input UI Map</b> field.  <b>Note:</b> You can search for a Input UI map, code, and an algorithm by clicking the <b>Search</b> icon (🔍) corresponding to the Approval Post Processing Algorithm field.	No

4. Enter the required details.
5. Add business objects and group BO relation with the approval workflow group, if required.
6. Click **Save**.

The approval workflow group is defined.

### Related Topics

For more information on...	See...
<b>Approval Workflow Group</b> screen	<a href="#">Approval Workflow Group (Used for Viewing)</a> on page 717
<b>Approval Workflow Group</b> zone	<a href="#">Approval Workflow Group</a> on page 718
How to add business objects and group BO relation	<a href="#">Adding a Business Object</a>

## Adding a Business Object

### Prerequisites

To add a business object in the approval workflow group, you should have:

- Business object and approval workflow group created in the application.

### Procedure

To add a business object in the approval workflow group:

1. Click the **Admin** link in the **Application** toolbar.  
A list appears.
2. From the **Admin** menu, Select **A**, and then click **Approval Workflow Group**.

The **Approval Workflow Group** screen appears.

- Click the **Add** button in the page-title area of the **Approval Workflow Group** screen.

The **Approval Workflow Group** screen appears. It contains following sections:

- Main** - Used to specify basic details of the approval workflow group.
- Business Objects and Group BO Relation** - Used to specify the fields that allow to define business and parent objects and link them with the approval workflow group.

The **Business Objects and Group BO Relation** section contains following fields:

Field Name	Field Description	Mandatory (Yes or No)
Business Object	Used to specify the Business Object Code that you want to include in the Approval Workflow Group.	Yes
Reference ID 1	Used to specify the XPATH key of the field in the business object that you want to display in the approval transaction information string.	Yes
Reference ID 2	Used to specify the XPATH key of the field in the business object that you want to display in the approval transaction information string.	Yes
Reference ID 3	Used to specify the XPATH key of the field in the business object that you want to display in the approval transaction information string.	Yes
Reference ID 4	Used to specify the XPATH key of the field in the business object that you want to display in the approval transaction information string.	Yes
Reference Foreign Key 1	Used to specify the XPATH key of the field in the business object that you want to use for validating whether duplicate approval transaction exists in the system.	No
Reference Foreign Key 2	Used to specify the XPATH key of the field in the business object that you want to use for validating whether duplicate approval transaction exists in the system.	No
Reference Foreign Key 3	Used to specify the XPATH key of the field in the business object that you want to use for validating whether duplicate approval transaction exists in the system.	No
Reference Foreign Key 4	Used to specify the XPATH key of the field in the business object that you want to use for validating whether duplicate approval transaction exists in the system.	No
Reference Foreign Key 5	Used to specify the XPATH key of the field in the business object that you want to use for validating whether duplicate approval transaction exists in the system.	No
Reference Foreign Key 6	Used to specify the XPATH key of the field in the business object that you want to use for validating whether duplicate approval transaction exists in the system.	No

Field Name	Field Description	Mandatory (Yes or No)
List	Used to indicate whether the group contains one or multiple instance of the business object. For example, if you want to create a group that contains multiple account objects, you need to set this flag for the Account BO to True. If you want to create a group that contains single instance of the business object, you must set this flag for the business object to False.	Yes
Parent Business Object	Used to specify the parent business object. This should be one of the business objects within the group.	No
From Key	Used to specify the XPATH key of the field or list of fields in the parent business object.	No
To Key	Used to specify the XPATH key of the field or list of fields in the current business object.	No

**Note:** You can search for a business object and parent business object, by clicking the **Search** () icon placed corresponding to the **Business Object** field.

- If you want to define more than one business and parent business object for the approval workflow group, click the **Add** () icon placed corresponding to the field.
- Enter the required details in **Main** and **Business Objects and Group BO Relation** sections.
- Click **Save**

The business object is added in the approval workflow group.

**Note:** When you add business objects in an approval workflow group, you need to regenerate the Input and Display UI maps by clicking the **Regenerate UI Maps** () icon corresponding to the group in the **Approval Workflow Settings** screen. You must do this only when you are using automatically generated UI maps, and not otherwise.

### Related Topics

For more information on...	See...
Approval Workflow Group screen	<a href="#">Approval Workflow Group (Used for Viewing)</a> on page 717
Approval Workflow Group zone	<a href="#">Approval Workflow Group</a> on page 718

## Defining a Group BO Relation

### Prerequisites

To define a relationship between business object in the approval workflow group, you should have:

- Business objects added in the approval workflow group.

### Procedure

To define a relationship between business objects in the approval workflow group:

- Click the **Admin** link in the **Application** toolbar.  
A list appears.
- From the **Admin** menu, Select **A** and then click **Approval Workflow Group**.  
The **Approval Workflow Group** screen appears.

3. Search for an approval workflow group in the **Approval Workflow Group** screen.
4. In the **Search Results** section, click the link in the **Description** column corresponding to the approval workflow group.
5. The **Approval Workflow Group** screen appears. It contains following sections:
  - **Main** - Used to specify basic details of the approval workflow group.
  - **Business Objects and Group BO Relation** - Used to specify the fields that allow to define business and parent objects, and link them with the approval workflow group.
6. Define and edit the approval workflow group details from the **Main** section, if required.
7. If you only want to define a business object, enter the required details in the **Business Objects and Group BO Relation** section.
8. If you want to define a group BO relation with the business object, enter the required details in the following fields.
  - a) **Parent Business Object**
  - b) **From Key**
  - c) **To Key**

**Note:** If you want to define more than one business or parent object, click the **Add** (+) icon and then repeat step 2. However, if you want to remove a business or parent object, click the **Delete** (🗑️) icon corresponding to the business or parent object field.

9. Click **Save**.

The business object is defined, and its relationship with the parent object is also defined in the approval workflow group.

### **Related Topics**

<b>For more information on...</b>	<b>See...</b>
How to define an approval workflow group	<a href="#">Defining an Approval Workflow Group</a> on page 710
How to define an approval workflow business object	<a href="#">Adding a Business Object</a>
How to define an approval workflow group BO object	<a href="#">Defining a Group BO Relation</a> on page 716

## **Approval Workflow Group (Used for Viewing)**

Once you define an approval workflow group, the **Approval Workflow Group** screen allows you to:

- Edit the details of an approval workflow group
- Edit the details of business objects and group business object relation
- Delete an approval workflow group
- Delete a business object and a group business object relation
- View the details of an approval workflow group

This screen consists of the following zone:

- [Approval Workflow Group](#) on page 718

## Approval Workflow Group

The **Approval Workflow Group** zone displays the details of the approval workflow group. It contains the following sections:

- **Main** - Displays basic information about the approval workflow group. It contains the following fields:

Field Name	Field Description
Approval Workflow Group	Displays the name of the approval workflow group.
Description	Displays the description of the approval workflow group.
Display UI Map	Indicates the UI map that will be used for viewing data of the business objects within the approval workflow group.  <b>Note:</b> It has a link. On clicking the link, the <b>UI Map</b> screen appears where you can view the details of the respective UI Map.
Input UI Map	Indicates the UI map that will be used for modifying data of the business objects within the approval workflow group.  <b>Note:</b> It has a link. On clicking the link, the <b>UI Map</b> screen appears where you can view the details of the respective UI Map.
Dependency Algorithm	Indicates the algorithm that will be triggered before creating the approval workflow request.  <b>Note:</b> This algorithm can be used to check all prerequisites before creating the approval workflow request.
Approval Algorithm	Indicates the algorithm that will be triggered after the approval workflow request is approved by the approver at the last level in the hierarchy.
Approval Post Processing Algorithm	Indicates the algorithm that will be triggered after the changes (which are approved by all approvers in the hierarchy) are committed to the database.
Transaction Creation Algorithm	Indicates the algorithm that will create approval workflow requests.  <b>Note:</b> It has a link. On clicking the link, the <b>Algorithm</b> screen appears where you can view the details of the respective algorithm.
Data Retrieval Algorithm	Indicates the algorithm that will be triggered to retrieve the original data of the business objects within the approval workflow group. This will help an approver to compare the original and new data in case where the submitter action is Update (UPD).  <b>Note:</b> It has a link. On clicking the link, the <b>Algorithm</b> screen appears where you can view the details of the respective algorithm.
Information Algorithm	Indicates the Approval Transaction information from the Approval Transactions that are created for a particular entity, based on the inputs of the XPath paths provided in the Reference IDs.
Compare Map	Indicates the customized Display UI map that you want to use for the approval workflow group. It overrides the UI map specified in the <b>Display UI Map</b> field.
Input Script	Indicates the customized Input UI map that you want to use for the approval workflow group. It overrides the UI map specified in the <b>Input UI Map</b> field.

- **Record Actions** - This section contains the following buttons:

Button Name	Button Description
Edit	Used to define, edit the approval workflow group. It is also used to delete the business objects and group BO relation.
Delete	Used to delete an approval workflow group.

- **Record Information** - This section contains the following fields:

Field Name	Field Description
Business Object	Indicates the business object using which the approval workflow group is created. In addition, a context menu appears corresponding to this field which helps in navigating to other screens in the application.  <b>Note:</b> It has a link. On clicking the link, the <b>Business Object</b> screen appears where you can view the details of the respective business object.

- **Business Objects And Group BO Relation** - The Business Objects And Group BO Relation contains the following fields:

Field Name	Field Description
Business Object	Indicates the Business Object that you want to include in the Approval Workflow Group.
Reference ID 1	Indicates the XPATH key of the field in the business object that you want to display in the approval transaction information string.
Reference ID 2	Indicates the XPATH key of the field in the business object that you want to display in the approval transaction information string.
Reference ID 3	Indicates the XPATH key of the field in the business object that you want to display in the approval transaction information string.
Reference ID 4	Indicates the XPATH key of the field in the business object that you want to display in the approval transaction information string.
Reference Foreign Key 1	Indicates the XPATH key of the field in the business object that you want to use for validating whether duplicate approval transaction exists in the system.
Reference Foreign Key 2	Indicates the XPATH key of the field in the business object that you want to use for validating whether duplicate approval transaction exists in the system.
Reference Foreign Key 3	Indicates the XPATH key of the field in the business object that you want to use for validating whether duplicate approval transaction exists in the system.
Reference Foreign Key 4	Indicates the XPATH key of the field in the business object that you want to use for validating whether duplicate approval transaction exists in the system.
Reference Foreign Key 5	Indicates the XPATH key of the field in the business object that you want to use for validating whether duplicate approval transaction exists in the system.
Reference Foreign Key 6	Indicates the XPATH key of the field in the business object that you want to use for validating whether duplicate approval transaction exists in the system.

Field Name	Field Description
List	Indicates whether the group contains one or multiple instance of the business object. For example, if you want to create a group that contains multiple account objects, you need to set this flag for the Account BO to True. If you want to create a group that contains single instance of the business object, you must set this flag for the business object to False.
Parent Business Object	Indicates the parent business object. This should be one of the business objects within the group.
From Key	Indicates the XPATH key of the field or list of fields in the parent business object.
To Key	Indicates the XPATH key of the field or list of fields in the current business object.

## Editing an Approval Workflow Group

### Procedure

To edit an approval workflow group:

1. Search for the approval workflow group in the **Approval Workflow Group**.
2. In the **Search Results** section, click the link in the **Description** column corresponding to the approval workflow group whose details you want to edit.

The **Approval Workflow Group** screen appears.

3. Click the **Edit** button in the **Approval workflow Group** zone.

The **Approval Workflow Group** screen appears.

4. Modify the details of the approval workflow group, if required.
5. Define, edit, or remove business objects and group BO relation from the approval workflow group, if required.
6. Click **Save**.

The changes made to the approval workflow group are saved.

### Related Topics

For more information on...	See...
How to search for an approval workflow group	<a href="#">Searching for an Approval Workflow Group</a> on page 709
How to add a business object	<a href="#">Adding a Business Object</a> on page 714
How to define a Group BO Relation	<a href="#">Defining a Group BO Relation</a> on page 716

## Deleting an Approval Workflow Group

### Procedure

To delete an approval workflow group:

1. Search for the approval workflow group in the **Search Approval Workflow Group** screen.
2. In the **Search Results** section, click the link in the **Description** column corresponding to the approval workflow group that you want to delete.
3. Click the **Delete** button in the **Approval Workflow Group** zone.

A message appears confirming whether you want to delete the approval workflow group.

4. Click **OK**.



The approval workflow group is deleted.

### Related Topics

For more information on...	See...
How to search for an approval workflow group	<a href="#">Searching for an Approval Workflow Group</a> on page 709

## Editing a Business Object

### Procedure

To edit a business object in the approval workflow group:

1. From the **Admin** menu, select **A** and then click **Approval Workflow Group**.  
The **Approval Workflow Group** screen appears.
2. Search for an approval workflow group in the **Search Approval Workflow Group** zone.
3. In the **Search Results** section, click the link in the **Description** column corresponding to the approval workflow group whose details you want to edit.
4. The **Approval Workflow Group** zone appears. Click the **Edit** button from **Record Action** sections.

The **Approval Workflow Group** screen appears. It contains the following sections:

- **Main** - Used to specify the basic details of the approval workflow group.
- **Business Objects and Group BO Relation** - Used to specify the fields that allow to define business objects and link them with the approval workflow group

The **Business Objects and Group BO Relation** section contains following fields:

Field Name	Field Description	Mandatory (Yes or No)
Business Object	Displays the Business Object Code that is included in the Approval Workflow Group.	Yes
Reference ID 1	Displays the XPATH key of the field in the business object that you want to use as criteria for searching approval workflow groups.	No
Reference ID 2	Displays the XPATH key of the field in the business object that you want to use as criteria for searching approval workflow groups.	No
Reference ID 3	Displays the XPATH key of the field in the business object that you want to use as criteria for searching approval workflow groups.	No
Reference ID 4	Displays the XPATH key of the field in the business object that you want to use as criteria for searching approval workflow groups.	No
Reference Foreign Key 1	Displays the XPATH key of the field in the business object that you want to use for validating whether duplicate approval transaction exists in the system.	No
Reference Foreign Key 2	Displays the XPATH key of the field in the business object that you want to use for validating whether duplicate approval transaction exists in the system.	No

Field Name	Field Description	Mandatory (Yes or No)
Reference Foreign Key 3	Displays the XPATH key of the field in the business object that you want to use for validating whether duplicate approval transaction exists in the system.	No
Reference Foreign Key 4	Displays the XPATH key of the field in the business object that you want to use for validating whether duplicate approval transaction exists in the system.	No
Reference Foreign Key 5	Displays the XPATH key of the field in the business object that you want to use for validating whether duplicate approval transaction exists in the system.	No
Reference Foreign Key 6	Displays the XPATH key of the field in the business object that you want to use for validating whether duplicate approval transaction exists in the system.	No
List	Indicates whether the group contains one or multiple instance of the business object. For example, if you want to create a group that contains multiple account objects, you need to set this flag for the Account BO to True. If you want to create a group that contains single instance of the business object, you must set this flag for the business object to False.	Yes
Parent Business Object	Used to specify the parent business object. This should be one of the business objects within the group.	No
From Key	Display the XPATH key of the field or list of fields in the parent business object.	No
To Key	Display the XPATH key of the field or list of fields in the current business object.	No

**Note:** You can search for a business object or parent business object by clicking the **Search**  icon placed corresponding to the **Business Object** and **Parent Business Object** field.

- If you want to define more than one business object or parent object for the approval workflow group, click the **Add**  icon placed corresponding to the field.
- Enter the required details in **Main** and **Business Objects and Group BO Relation** sections.
- Click **Save**.

The changes made to the business object in approval workflow group are saved.

**Note:** When you change business objects in an approval workflow group, you need to regenerate the Input and Display UI maps by clicking the **Regenerate UI Maps**  icon corresponding to the group in the **Approval Workflow Settings** screen. You must do this only when you are using automatically generated UI maps, and not otherwise.

### Related Topics

For more information on...	See...
<b>Approval Workflow Group</b> screen	<a href="#">Approval Workflow Group (Used for Searching)</a> on page 708
<b>Approval Workflow Group</b> zone	<a href="#">Search Approval Workflow Group</a> on page 708
How to delete a Business Object	<a href="#">Deleting a Business Object</a> on page 723

## Deleting a Business Object

### Procedure

To delete a business object in the approval workflow group:

1. Search for an approval workflow group in the **Approval Workflow Group** screen.
2. In the **Search Results** section, click the link in the **Description** column corresponding to the approval workflow group.

The **Approval Workflow Group** zone appears.

3. In the View section of **Approval Workflow Group**, click the **Edit** button.

The **Approval Workflow Group** window appears.

4. In the **Business Objects and Group BO Relation** zone, click the **Delete** (🗑️) icon corresponding to the business object that you want to delete.
5. Click **Save**.

The business object is deleted from the approval workflow group.

### Related Topics

For more information on...	See...
<b>Approval Workflow Group</b> screen	<a href="#">Approval Workflow Group (Used for Searching)</a> on page 708
<b>Approval Workflow Group</b> zone	<a href="#">Search Approval Workflow Group</a> on page 708

## Editing a Group BO Relation

### Procedure

To edit the business object's relationship details in the approval workflow group:

1. If required, filter the approval workflow group in the **Approval Workflow Group** screen.
2. In the **Search Results** section, click the link in the **Description** column corresponding to the approval workflow group.



The **Approval Workflow Group** screen appears. It contains following two sections:

- **Main** - Displays the basic details of the approval workflow group.
- **Business Objects and Group BO Relation** - Displays the fields that allow to define or edit business objects, and link them with the approval workflow group.

3. If required, define and edit the approval workflow group details from the **Main** section.
4. The **Business Objects and Group BO Relation** section contains following fields:

Field Name	Field Description	Mandatory (Yes or No)
Business Object	Used to specify the business object that you want to add in the approval workflow group.	Yes
Reference ID 1	Used to indicate the XPATH key of the field that you want to concatenate in the approval transaction information string.	No
Reference ID 2	Used to indicate the XPATH key of the field that you want to concatenate in the approval transaction information string.	No

Field Name	Field Description	Mandatory (Yes or No)
Reference ID 3	Used to indicate the XPATH key of the field that you want to concatenate in the approval transaction information string.	No
Reference ID 4	Used to indicate the XPATH key of the field that you want to concatenate in the approval transaction information string.	No
Reference Foreign Key 1	Used to indicate the XPATH key of the field that you want to use while validating whether a duplicate approval transaction does not exist in the system.	No
Reference Foreign Key 2	Used to indicate the XPATH key of the field that you want to use while validating whether a duplicate approval transaction does not exist in the system.	No
Reference Foreign Key 3	Used to indicate the XPATH key of the field that you want to use while validating whether a duplicate approval transaction does not exist in the system.	No
Reference Foreign Key 4	Used to indicate the XPATH key of the field that you want to use while validating whether a duplicate approval transaction does not exist in the system.	No
Reference Foreign Key 5	Used to indicate the XPATH key of the field that you want to use while validating whether a duplicate approval transaction does not exist in the system.	No
Reference Foreign Key 6	Used to indicate the XPATH key of the field that you want to use while validating whether a duplicate approval transaction does not exist in the system.	No
List	Indicates whether the group contains one or multiple instance of the business object. For example, if you want to create a group that contains multiple account objects, you need to set this flag for the Account BO to True. If you want to create a group that contains single instance of the business object, you must set this flag for the business object to False.	Yes
Parent Business Object	Displays the parent business object. This should be one of the business objects within the group.	No
From Key	Displays the XPATH key of the field or list of fields in the parent business object.	No
To Key	Displays the XPATH key of the field or list of fields in the current business object.	No

**Note:** You can search for a parent business object by clicking the **Search** () icon placed corresponding to the field. You can also define a new parent business object by clicking the **Add** () icon placed corresponding to the field.

5. Modify the required details in **Business Objects and Group BO Relation** section.
6. Click **Save**.

The changes made to business object's relationship are saved in the approval workflow group.

### Related Topics

For more information on...	See...
Search Approval Workflow Group screen	<a href="#">Approval Workflow Group (Used for Searching)</a> on page 708
Search Approval Workflow Group zone	<a href="#">Search Approval Workflow Group</a> on page 708
How to edit a Business Object	<a href="#">Editing a Business Object</a> on page 721
How to edit a Group BO Relation	<a href="#">Editing a Group BO Relation</a> on page 723

## Deleting a Group BO Relation

### Procedure

To delete the business object's relationship details in the approval workflow group:

1. If required, filter the approval workflow group in the **Approval Workflow Group** screen.
2. In the **Search Results** section, click the link in the **Description** column corresponding to the approval workflow group.
3. The **Approval Workflow Group** screen appears.
4. Click the **Edit** button in the **Record Actions** zone.  
The **Approval Workflow Group** screen appears.
5. In the **Business Objects and Group BO Relation** section, click the **Delete** () icon appearing next to the Business Object that you want to delete.
6. Click **Save**

The business object's relationship details are deleted from the approval workflow group.

### Related Topics

For more information on...	See...
Approval Workflow Group screen	<a href="#">Approval Workflow Group (Used for Searching)</a> on page 708
Approval Workflow Group zone	<a href="#">Search Approval Workflow Group</a> on page 708
How to delete a Business Object	<a href="#">Deleting a Business Object</a> on page 723
How to delete a Group BO Relation	<a href="#">Deleting a Group BO Relation</a> on page 725

## Approval Workflow Chain (Used for Searching)

The **Approval Workflow Chain** screen allows you to search for approval workflow chain using various search criteria. Through this screen, you can navigate to the following screen:

- [Approval Workflow Chain \(Used for Viewing\)](#) on page 729

This screen consists of the following zone:

- [Search Approval Workflow Chain](#) on page 725

## Search Approval Workflow Chain

The **Search Approval Workflow Chain** zone allows you to search for an approval workflow chain using various search criteria. It contains the following two sections:

- **Search Criteria** - The **Search Criteria** section contains the following fields:

Field Name	Field Description	Mandatory (Yes or No)
Approval Workflow Chain	Used to search a particular approval workflow chain.	No
Description	Used to search approval workflow chains with a particular description.	No

- **Search Results** - On clicking the **Search** button, the search results appear based on the specified search. The **Search Results** section contains the following columns:

Column Name	Column Description
Approval Workflow Chain	Displays the approval workflow chain.
Description	Displays the description of the approval workflow chain.  <b>Note:</b> It has a link. On clicking the link, the <b>Approval Workflow Chain</b> screen appears where you can view the details of the respective approval workflow chain.

**Note:** You must specify at least one search criterion while searching for an approval workflow chain.

### Related Topics

For more information on...	See...
How to search for an approval workflow chain	<a href="#">Searching for an Approval Workflow Chain</a> on page 726
How to view the details of an approval workflow chain	<a href="#">Viewing the Approval Workflow Chain Details</a> on page 727

## Searching for an Approval Workflow Chain

### Procedure

To search the approval workflow chain:

1. Click the **Admin** link in the **Application** toolbar.  
A list appears.
2. From the **Admin** menu, select **A** and then click **Approval Workflow Chain**.

The **Approval Workflow Chain** screen appears.

3. Enter the search criteria in the **Search Approval Workflow Chain** zone.

ORMB search engine supports wildcard search, where you can substitute the percentage (%) symbol as a stand in for any word or letter in a search criteria. You can use the ‘%’ wildcard character in all input fields except the date fields. The ‘%’ wildcard character is suffixed automatically at the end of the partial search criteria. Therefore, you may or may not specify the wildcard character at the end of the partial search criteria. However, you have to prefix the wildcard character manually wherever required.

4. Click **Search**.

A list of approval workflow chains that meet the search criteria appears in the **Search Results** section.

### Related Topics

<b>For more information on...</b>	<b>See...</b>
Search Approval Workflow Chain zone	<a href="#">Search Approval Workflow Chain</a> on page 725

## Viewing the Approval Workflow Chain Details

### Procedure

To view the details of an approval workflow chain:

1. Search for the approval workflow chain in the **Approval Workflow Chain** screen.
2. In the **Search Results** section, click the link in the **Description** column corresponding to the approval workflow chain whose details you want to view.

The **Approval Workflow Chain** screen appears. It contains the following zone:

- [Approval Workflow Chain](#) on page 729
3. View the details of the approval workflow chain in the **Approval Workflow Chain** zone.

### Related Topics

<b>For more information on...</b>	<b>See...</b>
How to search an approval workflow chain	<a href="#">Searching for an Approval Workflow Chain</a> on page 726

## Defining an Approval Workflow Chain

### Prerequisites

To define an approval workflow chain, you should have:

- The To Do role and To Do type defined in the application.
- Action algorithms defined in the application, in case you want to use any of them.

### Procedure

To define an approval workflow chain:

1. Click the **Admin** link in the **Application** toolbar.  
A list appears.
2. From the **Admin** menu, select **A** and then click **Approval Workflow Chain**.  
The **Approval Workflow Chain** screen appears.
3. Click the **Add** button in the **Page Title** area of the **Approval Workflow Chain** screen.  
The **Approval Workflow Chain** screen appears. It contains the following sections:
  - **Main** - Used to specify basic details of the approval workflow chain.
  - **Approval Levels** - Used to specify a level in the approval workflow chain.

The **Main** section contains the following fields:

Field Name	Field Description	Mandatory (Yes or No)
Approval Workflow Chain	Used to specify the approval workflow chain	Yes
Description	Used to specify the description for the approval workflow chain	Yes

Field Name	Field Description	Mandatory (Yes or No)
To Do Role To Resolve	Used to specify the To Do Role to indicate the users who will receive a notification when the approval transactions are rejected by an approver at any level in the hierarchy.	Yes

- Enter the required details.
- Define approval levels for the approval workflow chain, if required.
- Click **Save**.

The approval workflow chain is defined.

### Related Topics

For more information on...	See...
<b>Approval Workflow Chain</b> screen	<a href="#">Approval Workflow Chain (Used for Searching)</a> on page 725
<b>Approval Workflow Chain</b> zone	<a href="#">Approval Workflow Chain</a> on page 729
How to define Approval Levels for an approval workflow chain	<a href="#">Defining Approval Levels for an Approval Workflow Chain</a> on page 728

## Defining Approval Levels for an Approval Workflow Chain

### Prerequisites

To define approval levels in the approval workflow chain, you should have:



- The To Do Role and To Do Type defined in the application.
- Action algorithms defined in the application, in case you want to use any of them.

### Procedure

To define an approval levels for an approval workflow chain:

- Ensure that the **Approval Levels** section is expanded when you are defining or editing an approval workflow chain.

The **Approval Levels** section contains the following fields

Field Name	Field Description	Mandatory (Yes or No)
Action Algorithm	Used to specify the additional action that you want the system to perform apart from generating a notification when the approver approves or rejects the request.  <b>Note:</b> You can search for an action algorithm by clicking the <b>Search</b>  icon corresponding to the <b>Action Algorithm</b> field.	Yes
Approver To Do Role	Used to specify the To Do role to indicate the users who will either approve or reject the request at this level in the hierarchy.  <b>Note:</b> You can search for an approver to do role by clicking the <b>Search</b>  icon corresponding to the <b>Approver To Do Role</b> field.	Yes



Field Name	Field Description	Mandatory (Yes or No)
Approver To Do Type	Used to specify the type of notification that you want to generate when the approver approves or rejects the request.  <b>Note:</b> You can search for an approver to do type by clicking the <b>Search</b> (🔍) icon corresponding to the <b>Approver To Do Type</b> field.	Yes

- Enter the required details in the **Approval Levels** section.
- If you want to define more than one approval level for the approval workflow chain, click the **Add** (+) icon and then repeat step 2. However, if you want to remove a approval level from the approval workflow chain, click the **Delete** (🗑️) icon corresponding to the approval level.

### Related Topics

For more information on...	See...
How to define an approval workflow chain	<a href="#">Defining an Approval Workflow Chain</a> on page 727
How to edit an approval workflow chain	<a href="#">Editing an Approval Workflow Chain</a> on page 730

## Approval Workflow Chain (Used for Viewing)

Once you define an approval workflow chain, the **Approval Workflow Chain** screen allows you to:

- View the details of an approval workflow chain
- Edit an approval workflow chain
- Delete an approval workflow chain

This screen contains the following zone:

- [Approval Workflow Chain](#) on page 729

### Approval Workflow Chain

The **Approval Workflow Chain** zone displays the details of the approval workflow chain. It contains the following sections:

- Main** - Displays basic information about the approval workflow chain. It contains the following fields:

Field Name	Field Description
Approval Workflow Chain	Displays the approval workflow chain and levels.
Description	Displays the description of the approval workflow chain and levels.
To Do Role To Resolve	Displays the description of To Do Role role type.

- Approval Levels** - Displays the levels defined in the approval workflow chain.

Field Name	Field Description
Action Algorithm	Indicates the additional action that the system will perform apart from generating a notification when the approver approves or rejects the request.

Field Name	Field Description
Level	Indicates the level in the hierarchy.
Approver To Do Role	Indicates that the users with the specified To Do role will either approve or reject the request at this level in the hierarchy.
Approval To Do Type	Indicates the type of notification that will be generated when the approver approves or rejects the request.

- **Record Actions** - This section contains the following buttons:

Button Name	Button Description
Edit	Used to edit and delete the approval workflow chain and approval levels.
Delete	Used to delete the approval workflow chain.

- **Record Information** - This section contains the following field:

Field Name	Field Description
Business Object	Indicates the business object using which the approval workflow chain is created. In addition, a context menu appears corresponding to this field which helps in navigating to other screens in the application.  <b>Note:</b> It has a link. On clicking the link, the <b>Business Object</b> screen appears where you can view the details of the respective business object.

## Editing an Approval Workflow Chain

### Procedure

To edit an approval workflow chain:

1. Search for an approval workflow chain in the **Search Approval Workflow Chain** screen.
2. In the **Search Results** section, click the link in the **Description** column corresponding to the approval workflow chain whose details you want to edit.

The **Approval Workflow Chain** screen appears.

3. Click the **Edit** button in the **Approval Workflow Chain**.

The **Approval Workflow Chain** screen appears.

- **Main** - Used to specify the basic details of the approval workflow chain. It contains the following fields:

Field Name	Field Description	Mandatory (Yes or No)
Approval Workflow Chain	Displays the approval workflow chain.	Yes
Description	Displays the description for the approval workflow chain.	Yes
To Do Role To Resolve	Displays the To Do role to indicate the users who will be sent a notification when the approval workflow request is rejected by an approver at any level in the hierarchy.	Yes

- **Approval Levels** - Used to specify a level in the approval workflow chain. It contains the following fields:

Field Name	Field Description	Mandatory (Yes or No)
Action Algorithm	Displays the additional action that you want the system to perform apart from generating a notification when the approver approves or rejects the request.	Yes
Approver To Do Role	Displays the To Do role to indicate the users who will either approve or reject the request at this level in the hierarchy.	Yes
Approval To Do Type	Displays the type of notification that you want to generate when the approver approves or rejects the request.	Yes

4. Modify the required details in the **Main** section.
5. Edit, or remove approval levels from the approval workflow chain, if required.
6. Click **Save**.

The changes made to the approval workflow chain screen are saved.

### Related Topics

For more information on...	See...
<b>Approval Workflow Chain</b> screen	<a href="#">Approval Workflow Chain (Used for Viewing)</a> on page 729
<b>Approval Workflow Chain</b> zone	<a href="#">Approval Workflow Chain</a> on page 729
How to define approval levels for an approval workflow chain	<a href="#">Defining an Approval Workflow Chain</a> on page 727

## Deleting an Approval Workflow Chain

### Procedure

To delete an approval workflow chain:

1. Search for the approval workflow chain in the **Search Approval Workflow Chain** screen.
2. In the **Search Results** section, click the link in the **Description** column corresponding to the approval workflow chain that you want to delete.

The **Approval Workflow Chain** screen appears.

3. Click the **Delete** button in the **Approval Workflow Chain** zone.

A message appears confirming whether you want to delete the approval workflow chain.

4. Click **OK**.

The approval workflow chain is deleted.

### Related Topics

For more information on...	See...
How to search for an approval workflow chain	<a href="#">Searching for an Approval Workflow Chain</a> on page 726
<b>Approval Workflow Chain</b> screen	<a href="#">Approval Workflow Chain (Used for Viewing)</a> on page 729
<b>Approval Workflow Chain</b> zone	<a href="#">Approval Workflow Chain</a> on page 729

## Approval Workflow Criterion Type (Used for Searching)

The **Approval Workflow Criterion Type** screen allows you to search for an approval workflow criterion type using various search criteria. Through this screen, you can navigate to the following screen:

- [Approval Workflow Criterion Type \(Used for Viewing\)](#) on page 735

This screen consists of the following zone:

- [Search Approval Workflow Criterion Type](#) on page 732

### Search Approval Workflow Criterion Type

The **Search Approval Workflow Criterion Type** zone allows you to search for an approval workflow criterion type using various search criteria. It contains the following two sections:

- **Search Criteria** - The **Search Criteria** section contains the following fields:

Field Name	Field Description	Mandatory (Yes or No)
Approval Workflow Criterion Type	Used to search a particular approval workflow criterion type.	Yes
Description	Used to specify the description for the approval workflow criteria type.	No

**Note:** You must specify at least one search criterion while searching for an approval workflow criterion type.

- **Search Results** - On clicking the **Search** button, the search results are filtered based on the specified search criteria. The **Search Results** section contains the following columns:

Column Name	Column Description
Approval Workflow Criterion Type	Displays the approval workflow criterion type.
Description	Displays the description of the approval workflow criterion type.

### Related Topics

For more information on...	See...
How to search for an approval workflow criterion type	<a href="#">Searching for an Approval Workflow Criterion Type</a> on page 732
How to view the details of an approval workflow criterion type	<a href="#">Viewing the Approval Workflow Criterion Type Details</a> on page 733

## Searching for an Approval Workflow Criterion Type

### Procedure

To search the approval workflow criterion type:

1. Click the **Admin** link in the **Application** toolbar.  
A list appears.
2. From the **Admin** menu, select **A** and then click **Approval Workflow Criterion Type**.  
The **Approval Workflow Criterion Type** screen appears.
3. Enter the search criteria in the **Search Approval Workflow Criterion Type** zone.

**Note:** ORMB search engine supports wildcard search, where you can substitute the percentage (%) symbol as a stand in for any word or letter in a search criteria. You can use the ‘%’ wildcard character in all input fields except the date and ID fields. The ‘%’ wildcard character is suffixed automatically at the end of the partial search criteria. Therefore, you may or may not specify the wildcard character at the end of the partial search criteria. However, you have to prefix the wildcard character manually wherever required.

#### 4. Click **Search**

A list of approval workflow criterion types that meet the search criteria appears in the **Search Results** section.

#### Related Topics

For more information on...	See...
Approval Workflow Criterion Type screen	<a href="#">Approval Workflow Criterion Type (Used for Searching)</a> on page 732
Approval Workflow Criterion Type zone	<a href="#">Search Approval Workflow Criterion Type</a> on page 732

## Viewing the Approval Workflow Criterion Type Details

### Procedure

To view the details of an approval workflow criterion type:

1. If required, filter the approval workflow criterion type details in the **Search Approval Workflow Criterion Type** screen.
2. In the **Search Results** section, click the link in the **Description** column corresponding to the approval workflow criterion type whose details you want to view.

The **Approval Workflow Criterion** screen appears. It contains the following zone:

- [Approval Workflow Criterion Type](#) on page 735

3. View the details of the approval workflow criterion type in the **Approval Workflow Criterion Type** zone.

### Related Topics

For more information on...	See...
How to search the approval workflow criterion type	<a href="#">Searching for an Approval Workflow Criterion Type</a> on page 732
Approval Workflow Criterion Type screen	<a href="#">Approval Workflow Criterion Type (Used for Viewing)</a> on page 735
Approval Workflow Criterion Type zone	<a href="#">Approval Workflow Criterion Type</a> on page 735

## Defining an Approval Workflow Criterion Type

### Prerequisites

To define an approval workflow criterion type, you should have:

- Algorithm, Business object, and Field object defined in the application.

### Procedure

To define an approval workflow criterion type:

1. Click the **Admin** link in the **Application** toolbar.

A list appears.

- From the **Admin** menu, select **A** and then click **Approval Workflow Criterion Type**.



The **Approval Workflow Criterion Type** screen appears.

- Click the **Add** button in the **Page Title** area of the **Approval Workflow Criterion Type** screen.

The **Approval Workflow Criterion Type** screen appears. It contains the following section:

- Main** - Used to specify basic details about the approval workflow criterion type.

The **Main** section contains the following fields:

Field Name	Field Description	Mandatory (Yes or No)
Approval Workflow Criterion Type	Used to specify the approval workflow criterion type.	Yes
Description	Used to specify the description for the approval workflow criterion type.	Yes
Derived From	Used to indicate the option which triggers the approval workflow. The valid values are: <ul style="list-style-type: none"> <li>Algorithm</li> <li>Business Object</li> </ul>	Yes
Algorithm	Used to indicate the algorithm for which you want to define the approval workflow criterion type. <div style="border: 1px solid black; padding: 5px; margin-top: 10px;"> <p><b>Note:</b></p> <p>The <b>Search</b>  icon appears corresponding to this field. On clicking the Search icon, the Algorithm Search window appears.</p> <p>This field appears only when you select the Algorithm option form the Derived From list.</p> </div>	Yes
Business Object	Used to indicate the business object for which you want to define the approval workflow criterion type. <div style="border: 1px solid black; padding: 5px; margin-top: 10px;"> <p><b>Note:</b></p> <p>The <b>Search</b>  icon appears corresponding to this field. On clicking the Search icon, the Business Object Search window appears.</p> <p>This field appears only when you select the Business Object option form the Derived From list.</p> </div>	Yes

Field Name	Field Description	Mandatory (Yes or No)
Field	<p>Used to indicate the field that you want to use to define the criteria for associating approval workflow requests with the approval workflow chains.</p> <p><b>Note:</b></p> <p>The <b>Search</b>  icon corresponding to this field. On clicking the Search icon, the Field Search window appears.</p> <p>This field appears only when you select the Business Object option from the Derived From list.</p>	Yes

4. Enter the required details.
5. Click **Save**.

The approval workflow criterion type is created.

### Related Topics

For more information on...	See...
Approval Workflow Criterion Type screen	<a href="#">Approval Workflow Criterion Type (Used for Viewing)</a> on page 735
Search Approval Workflow Criterion Type zone	<a href="#">Search Approval Workflow Criterion Type</a> on page 732

## Approval Workflow Criterion Type (Used for Viewing)

Once you define an approval workflow criterion type, the **Approval Workflow Criterion Type** screen allows you to:

- Edit the details of an approval workflow criterion type
- Delete an approval workflow criterion type

This screen contains the following zone:

- [Approval Workflow Criterion Type](#) on page 735

### Approval Workflow Criterion Type

The **Approval Workflow Criterion Type** zone displays the details of the approval workflow criterion types. It contains the following sections:

- **Main** - Displays basic information about the approval workflow criterion type. It contains the following fields:

Field Name	Field Description
Approval Workflow Criterion Type	Displays the approval workflow criterion type.
Description	Displays the description of the approval workflow criterion type.
Derived From	<p>Indicates the criteria type that triggers the approval workflow. The valid values are:</p> <ul style="list-style-type: none"> <li>• Algorithm</li> <li>• Business Object</li> </ul>

Field Name	Field Description
Business Object	Indicates the business object using which the approval workflow criterion type is created. In addition, a context menu appears corresponding to this field which helps in navigating to other screens in the application.  <b>Note:</b> It has a link. On clicking the link, the <b>Business Object</b> screen appears where you can view the details of the respective business object.
Field	Indicates the field using which the criteria for associating approval workflow requests with the approval workflow chains will be defined.  <b>Note:</b> It has a link. On clicking the link, the <b>Fields</b> screen appears where you can view the details of the respective field.

- **Record Actions** - This section contains the following buttons:

Button Name	Button Description
Edit	Used to edit the approval workflow criterion type.
Delete	Used to delete the approval workflow criterion type.

- **Record Information** - This section contains the following field:

Field Name	Field Description
Business Object	Indicates the business object using which the approval workflow chain and levels is created. In addition, a context menu appears corresponding to this field which helps in navigating to other screens in the application.  <b>Note:</b> It has a link. On clicking the link, the <b>Business Object</b> screen appears where you can view the details of the respective business object.

## Editing an Approval Workflow Criterion Type

### Procedure

To edit an approval workflow criterion type:

1. Search for the approval workflow criterion type in the **Approval Workflow Criterion Type** screen.
2. In the **Search Results** section, click the link in the **Description** column corresponding to the approval workflow criterion type whose details you want to edit.

The **Approval Workflow Criterion Type** screen appears.



3. Click the **Edit** button in the **Approval Workflow Criterion Type** zone.

The **Approval Workflow Criterion Type** screen appears. It contains the following section:

- **Main** - This section contains the following fields:

Field Name	Field Description	Mandatory (Yes or No)
Approval Workflow Criterion Type	Displays the approval workflow criterion type.	Yes
Description	Displays the description for the approval workflow criterion type.	Yes



Field Name	Field Description	Mandatory (Yes or No)
Derived From	Displays an option which triggers the approval workflow.	Yes
Algorithm	<p>Displays the algorithm for which you want to define the approval workflow criterion type.</p> <p><b>Note:</b></p> <p>The <b>Search</b>  icon corresponding to this field. On clicking the Search icon, the Algorithm Search window appears</p> <p>This field appears only when you select the Algorithm option form the Derived From list.</p>	Yes
Business Object	<p>Displays the business object which is used to define the approval workflow criterion type.</p> <p><b>Note:</b></p> <p>The <b>Search</b>  icon corresponding to this field. On clicking the Search icon, the Business Object Search window appears.</p> <p>This field appears only when you select the Business Object option form the Derived From list.</p>	Yes
Field	<p>Displays the field which is used to define the criteria for associating approval workflow requests with the approval workflow chains.</p> <p><b>Note:</b></p> <p>The Search  icon corresponding to the respective field. On clicking the Search icon, the Field Search window appears.</p> <p>This field appears only when you select the Business Object option form the Derived From list.</p>	Yes

4. Modify the required details in the **Approval Workflow Criterion Type** screen.

5. Click **Save**.

The changes made to the approval workflow criterion type screen are saved.

#### **Related Topics**

For more information on...	See...
How to search for an approval workflow criterion type	<a href="#">Searching for an Approval Workflow Criterion Type</a> on page 732
<b>Approval Workflow Criterion Type</b> screen	<a href="#">Approval Workflow Criterion Type (Used for Viewing)</a> on page 735
<b>Approval Workflow Criterion Type</b> zone	<a href="#">Approval Workflow Criterion Type</a> on page 735

## Deleting an Approval Workflow Criterion Type

### Procedure

To delete an approval workflow criterion type:

1. Search for the approval workflow criterion type in the **Approval Workflow Criterion Type** screen.
2. In the **Search Results** section, click the link in the **Description** column corresponding to the approval workflow criterion type whose details you want to delete.

The **Approval Workflow Criterion Type** screen appears.

3. Click the **Delete** button in the **Approval Workflow Criterion Type** zone.

A message appears confirming whether you want to delete the approval workflow criterion type.

4. Click **OK**.

The approval workflow criterion type is deleted.

### Related Topics

For more information on...	See...
How to search for an approval workflow criterion type	<a href="#">Searching for an Approval Workflow Criterion Type</a> on page 732
<b>Approval Workflow Criterion Type</b> screen	<a href="#">Approval Workflow Criterion Type (Used for Viewing)</a> on page 735
<b>Approval Workflow Criterion Type</b> zone	<a href="#">Approval Workflow Criterion Type</a> on page 735

## Approval Workflow Group Chain Linkage (Used for Searching)

The **Approval Workflow Group Chain Linkage** screen allows you to search for an approval workflow group chain linkage using various search criteria. Through this screen, you can navigate to the following screen:

- [Approval Workflow Group Chain Linkage \(Used for Viewing\)](#) on page 744

This screen consists of the following zone:

- [Search Approval Workflow Group Chain Linkage](#) on page 738

For more information on...	See...
How to search for an approval workflow group chain linkage	<a href="#">Searching for an Approval Workflow Group Chain Linkage</a> on page 739
How to view the details of an approval workflow group chain linkage	<a href="#">Viewing the Approval Workflow Group Chain Linkage Details</a> on page 740

## Search Approval Workflow Group Chain Linkage

The **Search Approval Workflow Group Chain Linkage** zone allows you to search for an approval workflow group chain linkage using various search criteria. It contains the following two sections:

- **Search Criteria** - The **Search Criteria** section contains the following fields:

Field Name	Field Description	Mandatory (Yes or No)
Group Chain Linkage ID	Used to search a particular approval workflow group chain linkage.	Yes

Field Name	Field Description	Mandatory (Yes or No)
Approval Workflow Group	Used to search a group chain linkage for which an approval workflow group is defined.	Yes
Approval Workflow Chain	Used to search a group chain linkage for which an approval workflow chain is defined.	Yes

**Note:** You must specify at least one search criterion while searching for an approval workflow group chain linkage.

- **Search Results** - On clicking the **Search** button, the search results appear based on the specified search criteria.

The **Search Results** section contains the following columns:

Column Name	Column Description
Group Chain Linkage ID	Displays the ID which is generated automatically when the link is created.
Approval Workflow Group	Indicates the approval workflow group for which the link is created. <b>Note:</b> It has a link. On clicking the link, the <b>Approval Workflow Group Chain Linkage</b> screen appears with the details of the respective business object.
Approval Workflow Chain	Indicates the approval workflow chain for which the link is created.
Field Approval Rule	Indicates whether you want to configure approval rule for one or more fields of the business objects which are included in the approval workflow group. The valid values are: <ul style="list-style-type: none"> <li>• Yes</li> <li>• No</li> </ul>

### Related Topics

For more information on...	See...
How to search for an approval work group chain linkage	<a href="#">Searching for an Approval Workflow Group Chain Linkage</a> on page 739
How to view the details of an approval workflow group chain linkage	<a href="#">Viewing the Approval Workflow Group Chain Linkage Details</a> on page 740

## Searching for an Approval Workflow Group Chain Linkage

### Procedure

To search an approval workflow group chain linkage:

1. Click the **Admin** link in the **Application** toolbar.  
A list appears.
2. From the **Admin** menu, select **A** and then click **Approval Workflow Group Chain Linkage**.  
The **Approval Workflow Group Chain Linkage** screen appears.
3. Enter the search criteria in the **Search Group Chain Linkage** zone.

**Note:** ORMB search engine supports wildcard search, where you can substitute the percentage (%) symbol as a stand in for any word or letter in a search criteria. You can use the ‘%’ wildcard character in all input fields except the date and ID fields. The ‘%’ wildcard character is suffixed automatically at the end of the partial search criteria. Therefore, you may or may not specify the wildcard character at the end of the partial search criteria. However, you have to prefix the wildcard character manually wherever required.

#### 4. Click **Search**.

A list of group chain linkages that meet the search criteria appears in the **Search Results** section.

#### Related Topics

For more information on...	See...
<b>Approval Workflow Group Chain Linkage</b> screen	<a href="#">Approval Workflow Group Chain Linkage (Used for Searching)</a> on page 738
<b>Search Approval Workflow Group Chain Linkage</b> zone	<a href="#">Search Approval Workflow Group Chain Linkage</a> on page 738

## Viewing the Approval Workflow Group Chain Linkage Details

### Procedure

To view the details of an approval workflow chain linkage:

1. Search for the approval workflow group chain linkage in the **Approval Workflow Group Chain Linkage** screen.
2. In the **Search Results** section, click the link in the **Approval Workflow Group** column corresponding to the approval workflow chain whose details you want to view.

The **Approval Workflow Group Chain Linkage** screen appears. It contains the following zone:

- [Approval Workflow Group Chain Linkage](#) on page 745
3. View the details of the approval workflow group chain linkage in the **Approval Workflow Group Chain Linkage** zone.

#### Related Topics

For more information on...	See...
How to search for an approval workflow group chain linkage	<a href="#">Searching for an Approval Workflow Group Chain Linkage</a> on page 739
<b>Approval Workflow Group Chain Linkage</b> screen	<a href="#">Approval Workflow Group Chain Linkage (Used for Viewing)</a> on page 744

## Defining an Approval Workflow Group Chain Linkage

### Prerequisites

To define an approval workflow group chain linkage, you should have:

- Business Object, Field, Criterion Type, Approval Workflow Group and Approval Workflow Chain defined in the application.

### Procedure

To define an approval workflow group chain linkage:

1. Click the **Admin** link in the **Application** toolbar.

A list appears.

- From the **Admin** menu, select **A** and then click **Approval Workflow Group Chain Linkage**.

The **Approval Workflow Group Chain Linkage** screen appears.

- Click the **Add** button in the **Page Title** area of the **Approval Workflow Group Chain Linkage** screen.

The **Approval Workflow Group Chain Linkage** screen appears. It contains the following sections:

- Main** - Used to specify basic details about the approval workflow group chain linkage.
- Group Chain Linkage Criteria** - Used to define group chain linkage criteria for the approval workflow type.

The **Main** section contains the following fields:

Field Name	Field Description	Mandatory (Yes or No)
Approval Workflow Group	Used to indicate the approval workflow group.  <b>Note:</b> You can search for an approval workflow group type by clicking the Search (🔍) icon corresponding to the field.	Yes
Approval Workflow Chain	Used to indicate the approval workflow chain.  <b>Note:</b> You can search for an approval workflow chain by clicking the Search (🔍) icon corresponding to the field.	Yes
Field Approval Rule	Used to indicate whether you want to configure approval rule for one or more fields of the business objects which are included in the approval workflow group. The valid values are: <ul style="list-style-type: none"> <li>Yes</li> <li>No</li> </ul>	Yes

- Enter the required details.
- Define group chain linkage criteria for the approval workflow, if required.
- Define field approval rule criteria for the approval workflow, if required.
- Click **Save**.

The approval workflow group chain linkage is created.

### **Related Topics**

For more information on...	See...
<b>Approval Workflow Chain Linkage</b> screen	<a href="#">Approval Workflow Group Chain Linkage (Used for Searching)</a> on page 738
<b>Search Approval Workflow Chain Linkage</b> zone	<a href="#">Search Approval Workflow Group Chain Linkage</a> on page 738
How to define group chain linkage criteria for an approval workflow	<a href="#">Defining an Approval Workflow Group Chain Linkage</a> on page 740

## Defining Group Chain Linkage Criteria for an Approval Workflow

### Prerequisites

To define group chain linkage criteria for an approval workflow, you should have:

- Approval Workflow Criterion Type defined in the application.

### Procedure

To define group chain linkage criteria for an approval workflow:

1. Ensure that the **Group Chain Linkage Criteria** section is expanded when you are defining or editing an approval workflow.

The **Group Chain Linkage Criteria** section contains the following fields:

Field Name	Field Description	Mandatory (Yes or No)
Group Chain Linkage ID	Displays the Group Chain Linkage ID.  <b>Note:</b> The data appears in this field only when you are editing the details of an approval workflow criterion type.	Yes
Criterion Type	Used to indicate the criteria type needed for defining the criterion.  <b>Note:</b> The Search (🔍) icon appears corresponding to this field. On clicking the Search icon, the Approval Workflow Chain Search window appears.	Yes
Operator	Used to indicate the relational operator used to define the relation between the criterion type and criterion value.	Yes
Criterion Value	Used to specify the criterion value.	Yes

2. Enter the required details.
3. If you want to define more than one group chain linkage criteria for the approval workflow, click the **Add** (+) icon, and then repeat step 2.

**Note:** However, if you want to remove a group chain linkage criteria from the approval workflow, click the **Delete** (🗑️) icon corresponding to the group chain linkage criteria.

### Related Topics

For more information on...	See...
How to edit an approval workflow group chain linkage	<a href="#">Editing an Approval Workflow Group Chain Linkage</a> on page 747

## Defining a Field Approval Rule

### Prerequisites

To define a field approval rule for an approval workflow group chain linkage, you should have:



- Business Object, Field, and Approval Workflow Chain to be defined in the application.

**Procedure**

To define a field approval rule for an approval workflow group chain linkage:

1. Ensure that the **Field Approval Rule Criteria** section is expanded when you select the Yes option from the Field Approval Rule field of the Main section.

The **Field Approval Rule Criteria** section contains the following fields in a grid:

Field Name	Field Description	Mandatory (Yes or No)
Sequence.	Used to indicate the order in which the rule criteria should be executed while adding or updating the field value.	Yes
Applicable For	Used to indicate whether the rule criteria should be considered while adding and/or updating the field value. The valid values are: <ul style="list-style-type: none"> <li>• Add</li> <li>• Update</li> <li>• Add and Update</li> </ul>	Yes
Business Object	Used to indicate the business object in which the field is included. <div style="border: 1px solid black; padding: 5px; margin-top: 10px;"> <p><b>Note:</b></p> <p>The Search  icon appears corresponding to the <b>Business Object</b> field. On clicking the search icon, the <b>Search Group Based Business Object</b> search window appears.</p> </div>	Yes
Field	Used to indicate the field for which you want to define the approval rule criteria. <div style="border: 1px solid black; padding: 5px; margin-top: 10px;"> <p><b>Note:</b></p> <p>The Search  icon appears corresponding to the <b>Field</b> search field. On clicking the search icon, the <b>Field Search</b> search window appears.</p> </div>	Yes
Approval Workflow Chain	Used to indicate the approval workflow chain that you want to use for the field value approval. <div style="border: 1px solid black; padding: 5px; margin-top: 10px;"> <p><b>Note:</b></p> <p>The Search  icon appears corresponding to the <b>Approval Workflow Chain</b> field. On clicking the search icon, the <b>Approval Workflow Chain Search</b> search window appears.</p> </div>	Yes
Value Range	Used to indicate whether you want to define value based threshold limit for each approval level. <div style="border: 1px solid black; padding: 5px; margin-top: 10px;"> <p><b>Note:</b> This field is enabled only when the data type of the field is <b>Numeric</b>.</p> </div>	No

Field Name	Field Description	Mandatory (Yes or No)
Hierarchical	Used to indicate whether multi-level or single-level approval is required while adding or updating the field value beyond the threshold limit.	No

If the **Value Range** check box is selected, a grid appears with the following set of fields:

Field	Field Description
Threshold Value	Used to specify the threshold value using which you want to control the approval hierarchy.
Approval Level	Used to indicate the approval level at which approval is required when the field value is within the threshold value.  <div style="border: 1px solid black; padding: 5px;"> <p><b>Note:</b></p> <p>The <b>Search</b> (🔍) icon appears corresponding to the <b>Approval Level</b> field. On clicking the search icon, the <b>Approval Level Search</b> search window appears.</p> <hr/> <p><b>Note:</b> The search results will include all those levels which are defined in the approval workflow chain.</p> </div>
Approval Level Information	Displays additional information about the approval level.

- Enter the required details in the **Field Approval Rule Criteria** section.
- If you want to define more than one field approval rule criteria for the approval workflow chain linkage, click the **Add** (+) icon and then repeat step 2. However, if you want to remove a field approval rule criteria from the approval workflow chain linkage, click the **Delete** (🗑️) icon corresponding to the sequence field.
- Click **Save**.

The approval workflow field rule is defined.

#### Related Topics

For more information on...	See...
How to edit an approval workflow group chain linkage	<a href="#">Editing an Approval Workflow Group Chain Linkage</a> on page 747

## Approval Workflow Group Chain Linkage (Used for Viewing)

Once you define an approval workflow group chain linkage, the **Approval Workflow Group Chain Linkage** screen allows you to:

- Edit an approval workflow group chain linkage
- Delete an approval workflow group chain linkage

This screen contains the following zone:

- [Approval Workflow Group Chain Linkage](#) on page 745



For more information on...	See...
How to view the details of an approval workflow group chain linkage	<a href="#">Viewing the Approval Workflow Group Chain Linkage Details</a> on page 740

## Approval Workflow Group Chain Linkage

The **Approval Workflow Group Chain Linkage** zone displays the details of the approval workflow group chain linkage. It contains the following sections:

- **Main** - Displays basic information about the approval workflow group chain linkage. It contains the following fields:

Field Name	Field Description
Approval Workflow Group	Displays the approval workflow group for which a link is created.  <b>Note:</b> It has a link. On clicking the link, the <b>Approval Workflow Group</b> screen appears with the details of the respective approval workflow group.
Approval Workflow Chain	Displays the approval workflow chain for which a link is created.  <b>Note:</b> It has a link. On clicking the link, the <b>Approval Workflow Chain</b> screen appears with the details of the respective approval workflow group.
Field Approval Rule	Indicates whether you want to configure approval rule for one or more fields of the business objects which are included in the approval workflow group. The valid values are: <ul style="list-style-type: none"> <li>• Yes</li> <li>• No</li> </ul>

- **Record Actions** - This section contains the following buttons:

Button Name	Button Description
Edit	Used to edit the details of the approval workflow group chain linkage. Also used to define, edit, delete Group Chain Linkage Criteria and Field Approval Rule Criteria.
Delete	Used to delete the approval workflow group chain linkage.

- **Record Information** - This section contains the following field:

Field Name	Field Description
Business Object	Indicates the business object using which the approval workflow chain linkage is created. In addition, a context menu appears corresponding to this field which helps in navigating to other screens in the application.  <b>Note:</b> It has a link. On clicking the link, the <b>Business Object</b> screen appears where you can view the details of the respective business object.

- **Group Chain Linkage Criteria** - Lists the group chain linkage criteria..This section contains the following columns:

Column Name	Column Description
Group Chain Linkage ID	Displays the ID which is generated automatically when the link is created.

Column Name	Column Description
Criterion Type	Displays the criterion type needed for defining the criterion.  <b>Note:</b> It has a link. On clicking the link, the <b>Approval Workflow Criterion Type</b> screen appears where you can view the details of the respective criterion type.
Operator	Indicates the relational operator used to define the relation between the criterion type and criterion value. The valid values are: <ul style="list-style-type: none"> <li>EQUALS</li> <li>IN</li> </ul>
Criterion Value	Displays the criterion value.

- **Field Approval Rule Criteria** - Lists the field approval rule criteria for approval workflow group chain linkage. It contains the following columns:

Column Name	Column Description
Sequence	Indicates the order in which the rule criteria should be executed while adding or updating the field value.
Applicable For	Displays the rule criteria which should be considered while adding and/or updating the field value.
Business Object	Displays the business object in which the field is included.
Field	Displays the field for which you want to define the approval rule criteria.  <b>Note:</b> The <b>Context Menu</b> (☰) icon appears corresponding to the <b>Field</b> search field. On clicking the context menu icon, the <b>Go to Field</b> menu appears. On clicking the <b>Go to Field</b> menu item, the <b>Field</b> screen appears with the details of the respective field.  <b>Note:</b> It has a link. On clicking the link, the <b>Field</b> screen appears with the details of the respective field.
Approval Workflow Chain	Indicates the approval workflow chain that you want to use for the field value approval.  <b>Note:</b> It has a link. On clicking the link, the <b>Approval Workflow Chain</b> screen appears with the details of the respective approval workflow chain.
Value Range	Indicates whether you want to define value based threshold limit for each approval level.  <b>Note:</b> This field is enabled only when the data type of the field is <b>Numeric</b> .

Column Name	Column Description
Hierarchical Approval	Indicates whether multi-level or single-level approval is required while adding or updating the field value beyond the threshold limit.  <b>Note:</b> This field is enabled only when the <b>Value Range</b> check box is selected.

If the **Value Range** check box is selected, a grid appears with the following set of fields:

Field	Field Description
Threshold Value	Displays the threshold value using which you want to control the approval hierarchy.
Approval Level	Displays the approval level at which approval is required when the field value is within the threshold value.  <b>Note:</b> The <b>Search</b>  icon appears corresponding to the <b>Approval Level</b> field. On clicking the search icon, the <b>Approval Level Search</b> search window appears.  <b>Note:</b> The search results will include all those levels which are defined in the approval workflow chain.
Approval Level Information	Displays additional information about the approval level.

## Editing an Approval Workflow Group Chain Linkage

### Prerequisites

To edit an approval workflow group chain linkage, you should have:

- Business Object, Field, Criterion Type, Approval Workflow Group, and Approval Workflow Chain defined in the application.

### Procedure

To edit an approval workflow group chain linkage:

1. Search for the Approval Workflow Group Chain Linkage in the **Approval Workflow Group Chain Linkage** screen.
2. In the **Search Results** section, click the link in the **Approval Workflow Group** column corresponding to the approval workflow chain whose details you want to edit.  
The **Approval Workflow Group Chain Linkage** screen appears.
3. Click the **Edit** button in the **Approval Workflow Group Chain Linkage** zone.  
The **Approval Workflow Group Chain Linkage** screen appears.
4. Define or edit approval workflow group chain linkage, if required.
5. Define, edit or remove approval workflow criterion from the approval workflow group chain linkage, if required.
6. Define, edit or remove field approval rule criteria from the approval workflow group chain linkage, if required.
7. Click **Save**.

The changes made to the approval workflow group chain linkage screen are saved.

### Related Topics

For more information on...	See...
How to search approval workflow group chain linkage	<a href="#">Searching for an Approval Workflow Group Chain Linkage</a> on page 739
<b>Approval Workflow Group Chain Linkage</b> screen	<a href="#">Approval Workflow Group Chain Linkage (Used for Viewing)</a> on page 744
<b>Approval Workflow Group Chain Linkage</b> zone	<a href="#">Approval Workflow Group Chain Linkage</a> on page 745

## Deleting an Approval Workflow Group Chain Linkage

### Procedure

To delete an approval workflow group chain linkage:

1. Search for an approval workflow group chain linkage in the **Search Approval Workflow Group Chain Linkage** zone.
2. In the **Search Results** section, click the link in the **Approval Workflow Group** column corresponding to the approval workflow chain that you want to delete.

The **Approval Workflow Group Chain Linkage** screen appears.

3. Click the **Delete** button in the **Approval Workflow Group Chain Linkage** zone.

A message appears confirming whether you want to delete the approval workflow group chain linkage.

4. Click **OK**.

The approval workflow group chain linkage is deleted.

### Related Topics

For more information on...	See...
How to search for an approval workflow group chain linkage	<a href="#">Searching for an Approval Workflow Group Chain Linkage</a> on page 739

## Approval Workflow Setting (Used for Searching)

The **Approval Workflow Setting** screen allows you to search for approval workflow setting using various search criteria. It consists the following zone:

- [Search Approval Workflow Group](#) on page 748

Through this screen, you can navigate to the following screen:

- [Approval Workflow Setting \(Used for Viewing\)](#) on page 752

For more information on...	See...
How to search for an approval workflow setting	<a href="#">Searching for an Approval Workflow Group</a> on page 749
How to view the details of approval workflow settings	<a href="#">Viewing the Approval Workflow Setting Details</a> on page 750

## Search Approval Workflow Group

The **Search Approval Workflow Group** zone allows you to search for an approval workflow group using various search criteria. It contains the following two sections:

- **Search Criteria** - The **Search Criteria** section contains the following fields::

Field Name	Field Description	Mandatory (Yes or No)
Approval Workflow Group	Used to search a particular approval workflow group.	Yes
Description	Used to search approval workflow group with a particular description.	Yes

**Note:** You must specify at least one search criterion while searching for an approval workflow group.

- **Search Results** - On clicking the **Search** button, the search results appear based on the specified search criteria. The **Search Results** section contains the following columns:

Column Name	Column Description
Approval Workflow Group	Displays the approval workflow group.
Description	Displays the description of the approval workflow group.  <b>Note:</b> It has a link. On clicking the link, the <b>Approval Workflow Group</b> screen appears where you can view the details of the respective approval workflow group.

### **Related Topics**

For more information on...	See...
How to search for an approval workflow group	<a href="#">Searching for an Approval Workflow Group</a> on page 709
How to view the details of approval workflow setting	<a href="#">Viewing the Approval Workflow Setting Details</a> on page 750

## **Searching for an Approval Workflow Group**

### **Prerequisites**

To search for an approval workflow group, you should have:

- Approval Workflow Group defined in the application.
- Active flag should be set to **Yes**

### **Procedure**

To search for an approval workflow group:

1. Click the **Admin** link in the **Application** toolbar.  
A list appears.
2. From the **Admin** menu, Select **A** and then click **Approval Workflow Setting**.  
The **Approval Workflow Setting** screen appears.
3. Enter the search criteria in the **Search Approval Workflow Group** zone.

**Note:** ORMB search engine supports wildcard search, where you can substitute the percentage (%) symbol as a stand in for any word or letter in a search criteria. You can use the '%' wildcard character in all input fields except the date and ID fields. The '%' wildcard character is suffixed automatically at the end of the partial search criteria. Therefore, you may or may not specify the wildcard character at the end of the partial search criteria. However, you have to prefix the wildcard character manually wherever required.

#### 4. Click **Search**.

A list of approval workflow groups that meet the search criteria appears in the **Search Results** section.

#### Related Topics

For more information on...	See...
<b>Approval Workflow Setting</b> screen	<a href="#">Approval Workflow Setting (Used for Viewing)</a> on page 752
<b>Search Approval Workflow Group</b> zone	<a href="#">Search Approval Workflow Group</a> on page 708

## Viewing the Approval Workflow Setting Details

### Procedure

To view the details of approval workflow setting:

1. Search for an approval workflow group in the **Approval Workflow Setting** screen.
2. In the **Search Results** section, click the link in the **Description** column corresponding to the approval workflow group whose details you want to view.

The **Approval Workflow Settings** screen appears.

3. View the details of the approval workflow group in the **Approval Workflow Group Settings** zone.

### Related Topics

For more information on...	See...
<b>Approval Workflow Group Settings</b> screen	<a href="#">Approval Workflow Setting (Used for Viewing)</a> on page 752
<b>Approval Workflow Group Settings</b> zone	<a href="#">Approval Workflow Group Settings</a> on page 752
How to search for an approval workflow setting	<a href="#">Searching for an Approval Workflow Group</a> on page 749

## Defining Approval Workflow Group Settings

### Prerequisites

To define an approval workflow group setting, you should have:

- Approval Workflow Group defined in the application.
- Active flag set to **Yes**

### Procedure

To define an approval workflow group setting:

1. Click the **Admin** link in the **Application** toolbar.  
A list appears.
2. From the **Admin** menu, select **A** and then click **Approval Workflow Setting**.  
The **Approval Workflow Settings** screen appears.
3. Click the **Add** button in the **Page Title** area of the **Approval Workflow Settings** screen.

The **Approval Workflow Settings** screen appears. It contains the following section:

- **Main** - Used to specify the details for the approval workflow settings.

The **Main** section contains the following fields:

Field Name	Field Description	Mandatory (Yes or No)
Approval Workflow Group	Used to specify the approval workflow group.	Yes
Approval Chain Selection Algorithm	<p>Used to specify the algorithm that will be triggered before creating the approval workflow request.</p> <p><b>Note:</b> This algorithm identifies the approval workflow chain that must be used for the approval workflow group.</p> <p><b>Note:</b> You can search for an approval chain selection algorithm by clicking the <b>Search</b> (🔍) icon corresponding to the <b>Approval Chain Selection Algorithm</b> field.</p>	Yes
Prevalidation	<p>Used to indicate whether validation must be done before the approval workflow request is created. The valid values are:</p> <ul style="list-style-type: none"> <li>• Yes</li> <li>• No</li> </ul> <p><b>Note:</b> You can search for a prevalidation by clicking the <b>Search</b> (🔍) icon corresponding to the <b>Prevalidation</b> field.</p>	Yes
Approval Reason Required	<p>Used to indicate whether you want the approver to add reason and comments while approving the approval transaction. The valid values are:</p> <ul style="list-style-type: none"> <li>• Yes</li> <li>• No</li> </ul>	Yes
Active	<p>Used to indicate whether the approval workflow is required for the business objects in the approval workflow group. The valid values are:</p> <ul style="list-style-type: none"> <li>• <b>Yes</b> - Used when you want to activate the approval workflow for the business objects in the approval workflow group.</li> <li>• <b>No</b> - Used when you do not want to activate the approval workflow for the business objects in the approval workflow group.</li> <li>• <b>Conditional</b> - Used when you want to activate the approval workflow for business objects that satisfy particular criteria (for example, when the person or account belongs to a particular division). Note that, at present, this functionality works only for an approval workflow group which consists of a single business object.</li> </ul>	Yes

Field Name	Field Description	Mandatory (Yes or No)
Conditional Algorithm	Used to specify the algorithm that will be used to determine the business objects for which the approval workflow must be activated.  <b>Note:</b> This field appears only when the <b>Conditional</b> option is selected from the <b>Active</b> list.	Yes

4. Enter the required details.

5. Click **Save**.

The approval workflow group setting is defined.

#### Related Topics

For more information on...	See...
Approval Workflow Group screen	<a href="#">Approval Workflow Group (Used for Searching)</a> on page 708
Search Approval Workflow Group zone	<a href="#">Search Approval Workflow Group</a> on page 708

## Approval Workflow Setting (Used for Viewing)

Once the approval workflow group setting is defined, the **Approval Workflow Settings** screen allows you to:

- View the details of an approval workflow setting
- Edit the approval workflow group settings
- Delete an approval workflow group settings
- Regenerate approval workflow setting UI maps

This screen consists of the following zone:

- [Approval Workflow Group Settings](#) on page 752

For more information on...	See...
How to edit the approval workflow group settings	<a href="#">Editing Approval Workflow Group Settings</a> on page 754
How to delete an approval workflow group settings	<a href="#">Deleting Approval Workflow Group Settings</a> on page 754
How to regenerate UI Maps	<a href="#">Regenerating Input and Display UI Maps</a> on page 755

## Approval Workflow Group Settings

The **Approval Workflow Group Settings** zone displays the details of the approval workflow group settings. It contains the following sections:

- **Main** - Displays the basic information about the approval workflow group settings. It contains the following fields:

Field Name	Field Description
Approval Workflow Group	Displays the approval workflow group.



Field Name	Field Description
Approval Chain Selection Algorithm	<p>Displays the algorithm that will be triggered after creating the approval workflow request.</p> <p><b>Note:</b> This algorithm identifies the approval workflow chain that must be used for the approval workflow group.</p> <p><b>Note:</b> It has a link. On clicking the link, the <b>Algorithm</b> screen appears where you can view the details of the respective approval chain selection algorithm.</p>
Prevalidation	<p>Indicates whether validation must be done before the approval workflow request is created. The valid values are:</p> <ul style="list-style-type: none"> <li>• Yes</li> <li>• No</li> </ul>
Approval Reason Required	<p>Indicates whether you want the approver to add reason and comments while approving the approval transaction. The valid values are:</p> <ul style="list-style-type: none"> <li>• Yes</li> <li>• No</li> </ul>
Active	<p>Indicates whether the approval workflow is required for the business objects in the approval workflow group. The valid values are:</p> <ul style="list-style-type: none"> <li>• <b>Yes</b> - Used when you want to activate the approval workflow for the business objects in the approval workflow group.</li> <li>• <b>No</b> - Used when you do not want to activate the approval workflow for the business objects in the approval workflow group.</li> <li>• <b>Conditional</b> - Used when you want to activate the approval workflow for business objects that satisfy particular criteria (for example, when the person or account belongs to a particular division). Note that, at present, this functionality works only for an approval workflow group which consists of a single business object.</li> </ul>
Conditional Algorithm	<p>Displays the algorithm that will be used to determine the business objects for which the approval workflow must be activated.</p> <p><b>Note:</b> This field appears only when the <b>Conditional</b> option is selected from the <b>Active</b> list.</p> <p><b>Note:</b> It has a link. On clicking the link, the <b>Algorithm</b> screen appears where you can view the details of the respective conditional algorithm.</p>

- **Record Actions** - This section contains the following buttons:

Button Name	Button Description
Edit	Used to edit the settings of the approval workflow group.
Delete	Used to delete the approval workflow group setting.
Regenerate UI Maps	Used to regenerate the approval workflow group setting UI Maps.

- **Record Information** - This section contains the following fields:

Field Name	Field Description
Business Object	Indicates the business object using which the approval workflow reason is created. In addition, a context menu appears corresponding to this field which helps in navigating to other screens in the application.
	<b>Note:</b> It has a link. On clicking the link, the <b>Business Object</b> screen appears where you can view the details of the respective business object.

## Editing Approval Workflow Group Settings

### Prerequisites

To edit approval workflow group settings, you should have:

- Approval Chain Selection Algorithm defined in the application.
- Prevalidation, Approval Reason Required, and Active flag defined in the application.
- Conditional Algorithm defined in the application

### Procedure

To edit approval workflow group settings:

1. Search for the approval workflow group in the **Approval Workflow Setting** screen.
2. In the **Search Results** section, click the link in the **Description** column corresponding to the approval workflow group whose details you want to edit.

The **Approval Workflow Settings** screen appears.

3. Click the **Edit** button in the **Approval Workflow Group Settings** zone.

The **Approval Workflow Group Settings** screen appears.

4. Edit the settings for the approval workflow group, if required.
5. Click **Save**.

The changes made to the approval workflow group settings are saved.

### Related Topics

For more information on...	See...
How to search for an approval workflow group	<a href="#">Searching for an Approval Workflow Group</a> on page 709
<b>Approval Workflow Settings</b> screen	<a href="#">Approval Workflow Setting (Used for Viewing)</a> on page 752
<b>Approval Workflow Group Settings</b> zone	<a href="#">Approval Workflow Group Settings</a> on page 752

## Deleting Approval Workflow Group Settings

### Procedure

To delete approval workflow group settings:

1. Search for the approval workflow group in the **Approval Workflow Setting** screen.
2. In the **Search Results** section, click the link in the **Description** column corresponding to the approval workflow group that you want to delete.

The **Approval Workflow Settings** screen appears.

3. Click the **Delete** button in the **Approval Workflow Group Settings** zone.

A message appears confirming whether you want to delete the approval workflow group settings.

4. Click **OK**.

The approval workflow setting is deleted.

#### Related Topics

For more information on...	See...
How to search for an approval workflow group	<a href="#">Searching for an Approval Workflow Group</a> on page 709
<b>Approval Workflow Settings</b> screen	<a href="#">Approval Workflow Setting (Used for Viewing)</a> on page 752
<b>Approval Workflow Group Settings</b> zone	<a href="#">Approval Workflow Group Settings</a> on page 752

## Regenerating Input and Display UI Maps

### Procedure

To regenerate UI Maps for an approval workflow group setting:

1. Search for the approval workflow group in the **Approval Workflow Setting** screen.
2. In the **Search Results** section, click the link in the **Description** column corresponding to the approval workflow group for which you want to regenerate UI maps.

The **Approval Workflow Settings** screen appears.

3. Click the **Regenerate UI Maps** button in the **Approval Workflow Group Settings** zone.

A message appears confirming whether you want to replace the existing Input and Display UI Maps.

4. Click **OK**.

The Input and Display UI Maps are generated.

#### Related Topics

For more information on...	See...
How to search for an approval workflow group	<a href="#">Searching for an Approval Workflow Group</a> on page 709
<b>Approval Workflow Settings</b> screen	<a href="#">Approval Workflow Setting (Used for Viewing)</a> on page 752
<b>Approval Workflow Setting</b> zone	<a href="#">Approval Workflow Group Settings</a> on page 752

## Approval Workflow Reason (Used for Searching)

The **Approval Workflow Reason** screen allows you to search for an approval workflow reason using various search criteria. It also allows you to define an approval workflow reason. It contains the following zone:

- [Approval Workflow Reason List](#) on page 755

### Approval Workflow Reason List

The **Approval Workflow Reason List** zone lists the approval workflow reasons that are already defined in the system. It contains the following two sections:

- **Search Criteria** - The **Search Criteria** section contains the following fields:

Field Name	Field Description	Mandatory (Yes or No)
Approval Workflow Reason	Used to search a particular approval workflow reason.	No
Description	Used to search approval workflow reasons with a particular description.	No

- **Search Results** - On clicking the **Search** button, the search results are filtered based on the specified search criteria. The **Search Results** section contains the following columns:

Column Name	Column Description
Approval Workflow Reason	Displays the approval workflow reason.
Description	Displays the description of the approval workflow reason.
Reason Category	Indicates the category to which the approval workflow reason belongs. The valid values are: <ul style="list-style-type: none"> <li>• Approve</li> <li>• Cancel</li> <li>• Reject</li> </ul>

### Related Topics

For more information on...	See...
How to filter approval workflow reasons	<a href="#">Filtering the Approval Workflow Reasons</a> on page 756
How to view the details of an approval workflow reason	<a href="#">Viewing the Approval Workflow Reason Details</a> on page 757
How to define an approval workflow reason	<a href="#">Defining an Approval Workflow Reason</a> on page 757

## Filtering the Approval Workflow Reasons

### Procedure

To filter the approval workflow reasons:

1. Click the **Admin** link in the **Application** toolbar.  
A list appears.
2. From the **Admin** menu, select **A** and then click **Approval Workflow Reason**.  
The **Approval Workflow Reason** screen appears.
3. Enter the required search criteria in the **Approval Workflow Reason List** zone.

**Note:** ORMB search engine supports wildcard search, where you can substitute the percentage (%) symbol as a stand in for any word or letter in a search criteria. You can use the ‘%’ wildcard character in all input fields except the date and ID fields. The ‘%’ wildcard character is suffixed automatically at the end of the partial search criteria. Therefore, you may or may not specify the wildcard character at the end of the partial search criteria. However, you have to prefix the wildcard character manually wherever required.

4. Click **Search**.  
The search results are filtered based on the specified criteria.

### Related Topics

For more information on...	See...
Approval Workflow Reason screen	<a href="#">Approval Workflow Reason (Used for Searching)</a> on page 755
Approval Workflow Reason List zone	<a href="#">Approval Workflow Reason List</a> on page 755

## Viewing the Approval Workflow Reason Details

### Procedure

To view the details of an approval workflow reason:

1. If required, filter the approval workflow reasons in the **Approval Workflow Reason** screen.
2. In the **Search Results** section, click the link in the **Description** column corresponding to the approval workflow reason whose details you want to view.

The **Approval Workflow Reason** screen appears. It contains the following zone:

- [Approval Workflow Reason](#) on page 758

3. View the details of the approval workflow reason in the **Approval Workflow Reason** zone.

### Related Topics

For more information on...	See...
How to filter the approval workflow reasons	<a href="#">Filtering the Approval Workflow Reasons</a> on page 756
Approval Workflow Reason screen	<a href="#">Approval Workflow Reason (Used for Viewing)</a> on page 758

## Defining an Approval Workflow Reason

### Prerequisites

To define an approval workflow reason, you should have:

- Values defined for the **APPTXN\_REASON\_TYPE** lookup field

### Procedure

To define an approval workflow reason:

1. Click the **Admin** link in the **Application** toolbar.  
A list appears.
2. From the **Admin** menu, select **A** and then click **Approval Workflow Reason**.  
The **Approval Workflow Reason** screen appears.
3. Click the **Add** button in the **Page Title** area of the **Approval Workflow Reason** screen.

The **Approval Workflow Reason** screen appears. It contains the following fields:

Field Name	Field Description	Mandatory (Yes or No)
Approval Workflow Reason	Used to specify the approval workflow reason.	Yes
Description	Used to specify the description for the approval workflow reason.	Yes

Field Name	Field Description	Mandatory (Yes or No)
Reason Category	Used to indicate the category to which the approval workflow reason belongs. The valid values are: <ul style="list-style-type: none"> <li>• Approve</li> <li>• Cancel</li> <li>• Reject</li> </ul>	Yes

4. Enter the required details in the **Approval Workflow Reason** screen.

5. Click **Save**.

The approval workflow reason is defined.

### **Related Topics**

For more information on...	See...
<b>Approval Workflow Reason</b> screen	<a href="#">Approval Workflow Reason (Used for Searching)</a> on page 755

## **Approval Workflow Reason (Used for Viewing)**

Once you define an approval workflow reason, the **Approval Workflow Reason** screen allows you to:

- View the details of an approval workflow reason
- Edit and delete an approval workflow reason

This screen contains the following zone:

- [Approval Workflow Reason](#) on page 758

### **Approval Workflow Reason**

The **Approval Workflow Reason** zone displays the details of the approval workflow reason. It contains the following sections:

- **Main** - Displays basic information about the approval workflow reason. It contains the following fields:

Field Name	Field Description
Approval Workflow Reason	Displays the approval workflow reason.
Description	Displays the description of the approval workflow reason.
Reason Category	Indicates the category to which the approval workflow reason belongs. The valid values are: <ul style="list-style-type: none"> <li>• Approve</li> <li>• Cancel</li> <li>• Reject</li> </ul>

- **Record Actions** - This section contains the following buttons:

Button Name	Button Description
Edit	Used to edit the details of the approval workflow reason.
Delete	Used to delete the approval workflow reason.

- **Record Information** - This section contains the following field:

Field Name	Field Description
Business Object	Indicates the business object using which the approval workflow reason is created. In addition, a context menu appears corresponding to this field which helps in navigating to other screens in the application.  <b>Note:</b> It has a link. On clicking the link, the <b>Business Object</b> screen appears where you can view the details of the respective business object.

### **Related Topics**

For more information on...	See...
How to edit an approval workflow reason	<a href="#">Editing an Approval Workflow Reason</a> on page 759
How to delete an approval workflow reason	<a href="#">Deleting an Approval Workflow Reason</a> on page 760

## **Editing an Approval Workflow Reason**

### **Prerequisites**

To edit an approval workflow reason, you should have:

- Values defined for the **APPTXN\_REASON\_TYPE** lookup field

### **Procedure**

To edit an approval workflow reason:

1. Click the **Admin** link in the **Application** toolbar.  
A list appears.
2. From the **Admin** menu, select **A** and then click **Approval Workflow Reason**.  
The **Approval Workflow Reason** screen appears.
3. If required, filter the approval workflow reasons in the **Approval Workflow Reason** screen.
4. In the **Search Results** section, click the link in the **Description** column corresponding to the approval workflow reason whose details you want to edit.

The **Approval Workflow Reason** screen appears.

5. Click the **Edit** button in the **Approval Workflow Reason** zone.

The **Approval Workflow Reason** screen appears. It contains the following fields:

Field Name	Field Description	Mandatory (Yes or No)
Approval Workflow Reason	Displays the approval workflow reason.	Not applicable
Description	Used to specify the description for the approval workflow reason.	Yes

Field Name	Field Description	Mandatory (Yes or No)
Reason Category	Used to indicate the category to which the approval workflow reason belongs. The valid values are: <ul style="list-style-type: none"> <li>• Approve</li> <li>• Cancel</li> <li>• Reject</li> </ul>	Yes

6. Modify the required details in the **Approval Workflow Reason** screen.

7. Click **Save**.

The changes made to the approval workflow reason are saved.

### **Related Topics**

For more information on...	See...
How to filter the approval workflow reasons	<a href="#">Filtering the Approval Workflow Reasons</a> on page 756
<b>Approval Workflow Reason</b> screen	<a href="#">Approval Workflow Reason (Used for Viewing)</a> on page 758
<b>Approval Workflow Reason</b> zone	<a href="#">Approval Workflow Reason</a> on page 758

## **Deleting an Approval Workflow Reason**

### **Procedure**

To delete an approval workflow reason:

1. Click the **Admin** link in the **Application** toolbar.

A list appears.

2. From the **Admin** menu, select **A** and then click **Approval Workflow Reason**.

The **Approval Workflow Reason** screen appears.

3. If required, filter the approval workflow reasons in the **Approval Workflow Reason** screen.

4. In the **Search Results** section, click the link in the **Description** column corresponding to the approval workflow reason that you want to delete.

The **Approval Workflow Reason** screen appears.

5. Click the **Delete** button in the **Approval Workflow Reason** zone.

A message appears confirming whether you want to delete the approval workflow reason.

6. Click **OK**.

The approval workflow reason is deleted.

### **Related Topics**

For more information on...	See...
How to filter the approval workflow reasons	<a href="#">Filtering the Approval Workflow Reasons</a> on page 756
<b>Approval Workflow Reason</b> screen	<a href="#">Approval Workflow Reason (Used for Viewing)</a> on page 758
<b>Approval Workflow Reason</b> zone	<a href="#">Approval Workflow Reason</a> on page 758



---

# Chapter 8

---

## Rules Engine

---

### Topics:

- [Rule Type \(Used for Searching\)](#)
- [Rule Type \(Used for Viewing\)](#)
- [Rule](#)
- [View Rule](#)
- [Rule Check](#)

A rules engine executes one or more business rules in a runtime production environment. It allows you to define, execute, and maintain these business rules separately from the application code. You can then use these business rules in any program to facilitate operational decisions at runtime. For example, you might use business rules in the Collection module to decide the collection strategy or in the Banking module to derive charges codes or price items for the transaction.

A rules engine allows you to classify these rules using the rule type. It also allows you to define the relationship between two or more rules and set the priority for each rule. When a calling program invokes these rules using the rule type, all effective rules with the specified rule type are executed, starting with the rule having highest priority. For example, a rule with the priority 10 will be executed before a rule with the priority 20.

Each rule contains one or more criteria. Depending on whether the criteria is satisfied, the system either executes the next criteria or indicates whether the rule is true or false. The rules engine allows you to define what should happen when the rule is true or false. In both the cases, you can enforce the system to either:

- Execute any dependent rule
- Execute a rule with the same rule type having lower priority
- Return the output parameters and their values to the calling program

You can define a criteria for a rule only using the input parameters that are defined for the rule type. Also, when the rule is true, you can only return the output parameters that are defined for the rule type to the calling programs. Therefore, in case you want to use any field in the rule, you have to associate it with the rule type as an input or output parameter.

A rules engine also allows you to execute preprocessing and postprocessing algorithms. A preprocessing algorithm is triggered before executing any criteria in the rule. It pre-processes the input parameters and then returns processed values against which the criteria is validated. A postprocessing algorithm is triggered after executing all criteria in the rule. It post-processes the output parameters and returns the updated values to the calling programs or dependent rules.

Oracle Revenue Management and Billing provides you with the Rule Check utility. It allows you to validate whether rules defined with a specific rule type get executed as expected. On validating, it indicates the sequence in which the rules were executed, the total execution time, and displays the output parameters of the rule that was successfully executed.

Normally, in the Transaction Feed Management feature, the transaction legs are created using the output parameters of the rule where the criteria returns **Rule**

**Is True** and the rule true action is set to **Success**. Oracle Revenue Management and Billing also enables you to accumulate the output parameters of all rules where the criteria returns **Rule Is True** irrespective of whether the rule true action is set to **Next Dependent**, **Next Rule by Priority**, or **Success**. This accumulation process continues until a rule is executed where the criteria returns **Rule Is True** and the rule true action is set to **Success**. Once the output parameters are accumulated, the transactions legs are created using these accumulated output parameters. You can enable the rule output accumulation feature for the Transaction Feed Management module by setting the **Rule Output Accumulation** option type in the **C1\_FM** feature configuration to **true**.

There might be situations when duplicate transaction legs are created through the rule output accumulation process. The system enables you to indicate whether duplicate transaction legs must be created during the transaction aggregation cycle through the rule output accumulation process. If the **Remove Duplicates from Accumulated Rule Output** option type in **C1\_FM** feature configuration is set to **true**, the system does not create duplicate transaction legs during the transaction aggregation cycle.

**Note:** The transaction legs with the same account ID, price item, variance parameter or price item parameters, and processing date are considered as duplicate transaction legs.

## Rule Type (Used for Searching)

A rule type can be used for defining rule based auto pay instructions or business rules for mapping transactions with the price items. If you want to use the rule type for defining rule based auto pay instructions, you must set the **Rule Type Usage** field to **Auto Pay**. However, if you want to use the rule type for defining business rules for mapping transactions with the price items, you must leave the **Rule Type Usage** field blank.

It is the rule type which helps the system to determine:

- Fields that can be used while defining criteria for business rules or rule based auto pay instructions
- Entities whose characteristics can be used while defining criteria for rule based auto pay instructions
- Algorithms which must be used for deriving information from the financial transaction
- Maximum number of rules that can be defined when the rule based auto pay instruction is created using the rule type

The **Rule Type** screen allows you to search for a rule type using various search criteria. It also allows you to define, edit, delete, and copy a rule type. It contains the following zone:

- [Search Rule Type](#) on page 763

### Search Rule Type





The **Search Rule Type** zone allows you to search for a rule type using various search criteria. It contains the following two sections:

- **Search Criteria** - The **Search Criteria** section contains the following fields:

Field Name	Field Description	Mandatory (Yes or No)
Rule Type	Used to search a particular rule type.	No
Description	Used to search rule types with a particular description.	No
Rule Type Usage	Used to indicate whether you want to search rule types which are used for defining rule based auto pay instructions or which are used for defining business rules for mapping transactions with the price items. The valid value is: <ul style="list-style-type: none"> <li>• Auto Pay</li> </ul> <div style="border: 1px solid black; padding: 2px; margin-top: 5px;"> <p><b>Note:</b> If you want to search rule types which are used for defining business rules for mapping transactions with the price items, you must leave this field blank.</p> </div>	No

- **Search Results** - On clicking the **Search** button, the search results appear based on the specified search criteria. The **Search Results** section contains the following columns:

Column Name	Column Description
Rule Type	Displays the rule type.
Description	Displays the description of the rule type.
Rule Type Usage	Indicates whether the rule type is used for defining rule based auto pay instructions or for defining business rules for mapping transactions with the price items.

Column Name	Column Description
View	On clicking the <b>View</b> (  ) icon, the <b>Rule Type</b> screen appears where you can view the details of the rule type.
Edit	On clicking the <b>Edit</b> (  ) icon, the <b>Rule Type</b> screen appears where you can edit the details of the rule type.
Delete	On clicking the <b>Delete</b> (  ) icon, you can delete the rule type.  <b>Note:</b> You can delete a rule type only when the rule based auto pay instructions or business rules are not yet defined using the rule type.
Copy	On clicking the <b>Copy</b> (  ) icon, the <b>Rule Type</b> screen appears where you can create a new rule type using an existing rule type.

### Related Topics

For more information on...	See...
How to search for a rule type	<a href="#">Searching for a Rule Type</a> on page 764
How to view the details of a rule type	<a href="#">Viewing the Rule Type Details</a> on page 775
How to edit a rule type	<a href="#">Editing a Rule Type</a> on page 770
How to delete a rule type	<a href="#">Deleting a Rule Type</a> on page 772
How to copy a rule type	<a href="#">Copying a Rule Type</a> on page 773

## Searching for a Rule Type

### Prerequisites

To search for a rule type, you should have:

- Values defined for the **C1\_RULE\_USAGE\_FLG** lookup field

### Procedure

To search for a rule type:

1. Click the **Admin** link in the **Application** toolbar.  
A list appears.
2. From the **Admin** menu, select **R** and then click **Rule Type**.  
A sub-menu appears.
3. Click the **Search** option from the **Rule Type** sub-menu.  
The **Rule Type** screen appears.
4. Enter the search criteria in the **Search Rule Type** zone.

**Note:** ORMB search engine supports wildcard search, where you can substitute the percentage (%) symbol as a stand in for any word or letter in a search criteria. You can use the ‘%’ wildcard character in all input fields except the date and ID fields. The ‘%’ wildcard character is suffixed automatically at the end of the partial search criteria. Therefore, you may or may not specify the wildcard character at the end of the partial search criteria. However, you have to prefix the wildcard character manually wherever required.

5. Click **Search**.

A list of rule types that meet the search criteria appears in the **Search Results** section.

### Related Topics

For more information on...	See...
<b>Rule Type</b> screen	<a href="#">Rule Type (Used for Searching)</a> on page 763
<b>Search Rule Type</b> zone	<a href="#">Search Rule Type</a> on page 763

## Defining a Rule Type

### Prerequisites

To define a rule type, you should have:

- Values defined for the **C1\_RULE\_USAGE\_FLG** lookup field

### Procedure

To define a rule type:

1. Click the **Admin** link in the **Application** toolbar.  
A list appears.
2. From the **Admin** menu, select **R** and then click **Rule Type**.  
A sub-menu appears.
3. Click the **Add** option from the **Rule Type** sub-menu.

The **Rule Type** screen appears. It contains the following sections:

- **Main** - Used to specify basic details about the rule type.
- **Input and Output Parameters** - Used to define input and output parameters for the rule type.
- **Rule Criteria Characteristic Entities** - Used to indicate the entities whose characteristics you can use while defining rule based auto pay instructions using the rule type.

**Note:** This section appears only when you select the **Auto Pay** option from the **Rule Type Usage** list.

- **Rule Criteria Derivation Algorithms** - Used to attach algorithms which you want to use for deriving the following from the financial transaction:
  - Values of all those fields (such as, policy number, plan number, or price item) which are selected in the rule type as the input and output parameters
  - Characteristics of all those entities which are selected in the rule type as the rule criteria characteristic entities

**Note:** This section appears only when you select the **Auto Pay** option from the **Rule Type Usage** list.

The **Main** section contains the following fields:

Field Name	Field Description	Mandatory (Yes or No)
Rule Type	Used to specify the rule type.	Yes

Field Name	Field Description	Mandatory (Yes or No)
Rule Type Usage	Used to indicate whether you want to use the rule type for defining rule based auto pay instructions or for defining business rules for mapping transactions with the price items. The valid value is: <ul style="list-style-type: none"> <li>Auto Pay</li> </ul> <div style="border: 1px solid black; padding: 5px; margin-top: 10px;"> <p><b>Note:</b> If you want to use the rule type for defining rule based auto pay instructions, you must set the rule type usage to <b>Auto Pay</b>. However, if you want to use the rule type for defining business rules for mapping transactions with the price items, you must leave this field blank.</p> </div>	No
Description	Used to specify the description for the rule type.	Yes
Maximum Rule Count	Used to indicate the maximum number of rules that can be defined when the rule based auto pay instruction is created using the rule type. <div style="border: 1px solid black; padding: 5px; margin-top: 10px;"> <p><b>Note:</b> This field appears only when you select the <b>Auto Pay</b> option from the <b>Rule Type Usage</b> list. The maximum rule count cannot be less than or equal to zero.</p> </div>	No

**Tip:** Alternatively, you can access this screen by clicking the **Add** button in the **Page Title** area of the **Rule Type** screen.

- Enter the required details in the **Main** section.
- Define input and output parameters for the rule type.
- Associate one or more characteristic entities with the rule type, if required.

**Note:** You must specify at least one input or output parameter when you want to use the rule type for defining business rules for mapping transactions with the price items. However, you must specify at least one input or output parameter or associate at least one characteristic entity when you want to use the rule type for defining rule based auto pay instructions.

- Associate the rule criteria derivation algorithm when you want to use the rule type for defining rule based auto pay instructions.

**Note:** You must associate the rule criteria derivation algorithm with the rule type when the **Rule Type Usage** field is set to **Auto Pay**.

- Click **Save**.

The rule type is defined.

### Related Topics

For more information on...	See...
How to define input and output parameters for a rule type	<a href="#">Defining Input and Output Parameters for a Rule Type</a> on page 767

For more information on...	See...
How to associate a characteristic entity with a rule type	<a href="#">Associating a Characteristic Entity with a Rule Type</a> on page 768
How to associate an algorithm with a rule type	<a href="#">Associating an Algorithm with a Rule Type</a> on page 769

## Defining Input and Output Parameters for a Rule Type

### Prerequisites

To define the input and output parameters for a rule type, you should have:

- Fields defined in the application
- Field search zone defined in the application

### Procedure

To define the input and output parameters for a rule type:

1. Ensure that the **Input and Output Parameters** section is expanded when you are defining, editing, or copying a rule type.

The **Input and Output Parameters** section contains the following fields in a grid:

Field Name	Field Description	Mandatory (Yes or No)
Sequence	Used to specify the sequence number for the input or output parameter.	Yes
Field	Used to indicate the field that you want to use as the input or output parameter.  <b>Note:</b> The <b>Search</b>  icon appears corresponding to this field. On clicking the <b>Search</b> icon, the <b>Field Search</b> window appears.	Yes
Rule Input/Output	Used to indicate whether you want to use the field as input and/or output parameter while defining a business rule. The valid values are: <ul style="list-style-type: none"> <li>• Input</li> <li>• Input and Output</li> <li>• Output</li> </ul> <b>Note:</b> By default, the <b>Input</b> option is selected. This field appears only when you do not select the <b>Auto Pay</b> option from the <b>Rule Type Usage</b> list.	Yes

Field Name	Field Description	Mandatory (Yes or No)
Search Zone	<p>Used to indicate the search zone that you want to use for searching the field value while defining criteria for rule based auto pay instructions.</p> <div style="border: 1px solid black; padding: 5px;"> <p><b>Note:</b></p> <p>The <b>Search</b>  icon appears corresponding to this field. On clicking the <b>Search</b> icon, the <b>Zone Search</b> window appears.</p> <p>This field appears only when you select the <b>Auto Pay</b> option from the <b>Rule Type Usage</b> list.</p> </div>	No

- Enter the required details in the **Input and Output Parameters** section.

<p><b>Note:</b></p> <p>At present, the following fields are only supported while defining a rule type where the <b>Rule Type Usage</b> field is set to <b>Auto Pay</b>:</p> <ul style="list-style-type: none"> <li>• Policy Number</li> <li>• Plan Number</li> <li>• Price Item</li> </ul> <p>If you want to use any other field while defining criteria for rule based auto pay instructions, the implementation team will have to develop the custom logic to implement the requirement.</p>
--

- If you want to define more than one input or output parameter for the rule type, click the **Add**  icon and then repeat step 2.

<p><b>Note:</b> However, if you want to remove an input or output parameter from the rule type, click the <b>Delete</b>  icon corresponding to the parameter.</p>
--

### Related Topics

For more information on...	See...
How to define a rule type	<a href="#">Defining a Rule Type</a> on page 765
How to edit a rule type	<a href="#">Editing a Rule Type</a> on page 770
How to copy a rule type	<a href="#">Copying a Rule Type</a> on page 773

## Associating a Characteristic Entity with a Rule Type

### Prerequisites

To associate a characteristic entity with a rule type, you should have:

- Values defined for the **RULE\_CRITERIA\_ENTITY\_FLG** lookup field

### Procedure

To associate a characteristic entity with a rule type:

- Ensure that the **Rule Criteria Characteristic Entities** section is expanded when you are defining, editing, or copying a rule type.

The **Rule Criteria Characteristic Entities** section contains the following fields in a grid:



Field Name	Field Description	Mandatory (Yes or No)
Characteristic Entity	<p>Used to indicate the entity whose characteristics you want to use while defining criteria for rule based auto pay instructions. The valid values are:</p> <ul style="list-style-type: none"> <li>• Adjustment</li> <li>• Billable Charge</li> <li>• Policy</li> <li>• Policy Plan</li> <li>• Price Item</li> </ul> <p><b>Note:</b> At present, the characteristics of the above listed entities are only supported while defining criteria for rule based auto pay instructions. If you want to use characteristics of any other entity, the implementation team will have to develop the custom logic to implement the requirement.</p>	Yes

**Note:** This section appears only when you select the **Auto Pay** option from the **Rule Type Usage** list.

- Enter the required details in the **Rule Criteria Characteristic Entities** section.
- If you want to associate more than one characteristic entity with the rule type, click the **Add (+)** icon and then repeat step 2.

**Note:** However, if you want to remove a characteristic entity from the rule type, click the **Delete (🗑)** icon corresponding to the characteristic entity.

### Related Topics

For more information on...	See...
How to define a rule type	<a href="#">Defining a Rule Type</a> on page 765
How to edit a rule type	<a href="#">Editing a Rule Type</a> on page 770
How to copy a rule type	<a href="#">Copying a Rule Type</a> on page 773

## Associating an Algorithm with a Rule Type

### Prerequisites

To associate an algorithm with a rule type, you should have:

- Rule criteria derivation algorithm defined using the **C1-APRCRIDER** algorithm type

### Procedure

To associate an algorithm with a rule type:

- Ensure that the **Rule Criteria Derivation Algorithms** section is expanded when you are defining, editing, or copying a rule type.

The **Rule Criteria Derivation Algorithms** section contains the following fields in a grid:

Field Name	Field Description	Mandatory (Yes or No)
Sequence	Used to indicate the order in which the algorithm should be executed.	Yes
Algorithm	<p>Used to attach an algorithm which you want to use for deriving the following from the financial transaction:</p> <ul style="list-style-type: none"> <li>• Values of all those fields (such as, policy number, plan number, or price item) which are selected in the rule type as the input and output parameters</li> <li>• Characteristics of all those entities which are selected in the rule type as the rule criteria characteristic entities</li> </ul> <p><b>Note:</b> The <b>Search</b> (🔍) icon appears corresponding to this field. On clicking the <b>Search</b> icon, the <b>Algorithm Search</b> window appears.</p>	Yes

**Note:** This section appears only when you select the **Auto Pay** option from the **Rule Type Usage** list.

2. Enter the required details in the **Rule Criteria Derivation Algorithms** section.
3. If you want to associate more than one algorithm with the rule type, click the **Add** (+) icon and then repeat step 2.

**Note:** However, if you want to remove an algorithm from the rule type, click the **Delete** (🗑️) icon corresponding to the algorithm.

### Related Topics

For more information on...	See...
How to define a rule type	<a href="#">Defining a Rule Type</a> on page 765
How to edit a rule type	<a href="#">Editing a Rule Type</a> on page 770
How to copy a rule type	<a href="#">Copying a Rule Type</a> on page 773

## Editing a Rule Type

### Procedure

To edit a rule type:

1. Search for the rule type in the **Rule Type** screen.
2. In the **Search Results** section, click the **Edit** (✎) icon in the **Edit** column corresponding to the rule type whose details you want to edit.

The **Rule Type** screen appears. It contains the following sections:

- **Main** - Used to specify basic details about the rule type.
- **Input and Output Parameters** - Used to define input and output parameters for the rule type.
- **Rule Criteria Characteristic Entities** - Used to indicate the entities whose characteristics you can use while defining rule based auto pay instructions using the rule type.

**Note:** This section appears only when you select the **Auto Pay** option from the **Rule Type Usage** list.

- **Rule Criteria Derivation Algorithms** - Used to attach algorithms which you want to use for deriving the following from the financial transaction:
  - Values of all those fields (such as, policy number, plan number, or price item) which are selected in the rule type as the input and output parameters
  - Characteristics of all those entities which are selected in the rule type as the rule criteria characteristic entities

**Note:** This section appears only when you select the **Auto Pay** option from the **Rule Type Usage** list.

The **Main** section contains the following fields:

Field Name	Field Description	Mandatory (Yes or No)
Rule Type	Displays the rule type.	Not applicable
Rule Type Usage	Indicates whether the rule type is used for defining rule based auto pay instructions or for defining business rules for mapping transactions with the price items.	Not applicable
Description	Used to specify the description for the rule type.	Yes
Maximum Rule Count	<p>Used to indicate the maximum number of rules that can be defined when the rule based auto pay instruction is created using the rule type.</p> <p><b>Note:</b> This field appears only when the <b>Rule Type Usage</b> field is set to <b>Auto Pay</b>. The maximum rule count cannot be less than or equal to zero. You cannot reduce the maximum rule count when one or more auto pay instructions contain the specified number of rules.</p>	No

**Tip:** Alternatively, you can edit the details of a rule type by clicking the **Edit** link in the **Rule Type** zone.

3. Modify the required details in the **Main** section.
4. Define, edit, or remove input or output parameters from the rule type, if required.

**Note:** You cannot edit or remove an input or output parameter from the rule type when it is used for defining criteria in a business rule or rule based auto pay instruction.

5. Associate or remove one or more characteristic entities from the rule type, if required.

**Note:**

You must specify at least one input or output parameter when you want to use the rule type for defining business rules for mapping transactions with the price items. However, you must specify at least one input or output parameter or associate at least one characteristic entity when you want to use the rule type for defining rule based auto pay instructions.

You cannot remove a characteristic entity from the rule type when it is used for defining criteria in a rule based auto pay instruction.

- Associate or remove one or more rule criteria derivation algorithm from the rule type, if required.

**Note:** You must associate the rule criteria derivation algorithm with the rule type when the **Rule Type Usage** field is set to **Auto Pay**.

- Click **Save**.

The changes made to the rule type are saved.

**Related Topics**

For more information on...	See...
How to search for a rule type	<a href="#">Searching for a Rule Type</a> on page 764
How to define input and output parameters for a rule type	<a href="#">Defining Input and Output Parameters for a Rule Type</a> on page 767
How to associate a characteristic entity with a rule type	<a href="#">Associating a Characteristic Entity with a Rule Type</a> on page 768
How to associate an algorithm with a rule type	<a href="#">Associating an Algorithm with a Rule Type</a> on page 769
<b>Rule Type</b> zone	<a href="#">Rule Type</a> on page 775

**Deleting a Rule Type****Procedure**

To delete a rule type:

- Search for the rule type in the **Rule Type** screen.
- In the **Search Results** section, click the **Delete** (🗑️) icon in the **Delete** column corresponding to the rule type that you want to delete.

A message appears confirming whether you want to delete the rule type.

**Note:** You can delete a rule type only when the rule based auto pay instructions or business rules are not yet defined using the rule type.

- Click **OK**.

The rule type is deleted.

**Related Topics**

For more information on...	See...
How to search for a rule type	<a href="#">Searching for a Rule Type</a> on page 764

## Copying a Rule Type

Instead of creating a rule type from scratch, you can create a new rule type using an existing rule type. This is possible through copying a rule type. On copying a rule type, the details including the input and output parameters, rule criteria characteristic entities, and rule criteria derivation algorithms are copied to the new rule type. You can then edit the details, if required.

### Prerequisites

To copy a rule type, you should have:

- Rule type (whose copy you want to create) defined in the application
- Values defined for the **C1\_RULE\_USAGE\_FLG** lookup field

### Procedure

To copy a rule type:

1. Search for the rule type in the **Rule Type** screen.
2. In the **Search Results** section, click the **Copy** () icon in the **Copy** column corresponding to the rule type whose copy you want to create.

The **Rule Type** screen appears. It contains the following sections:

- **Main** - Used to specify basic details about the rule type.
- **Input and Output Parameters** - Used to define input and output parameters for the rule type.
- **Rule Criteria Characteristic Entities** - Used to indicate the entities whose characteristics you can use while defining rule based auto pay instructions using the rule type.

**Note:** This section appears only when you select the **Auto Pay** option from the **Rule Type Usage** list.

- **Rule Criteria Derivation Algorithms** - Used to attach algorithms which you want to use for deriving the following from the financial transaction:
  - Values of all those fields (such as, policy number, plan number, or price item) which are selected in the rule type as the input and output parameters
  - Characteristics of all those entities which are selected in the rule type as the rule criteria characteristic entities

**Note:** This section appears only when you select the **Auto Pay** option from the **Rule Type Usage** list.

The **Main** section contains the following fields:

Field Name	Field Description	Mandatory (Yes or No)
Rule Type	Used to specify the rule type.	Yes

Field Name	Field Description	Mandatory (Yes or No)
Rule Type Usage	Used to indicate whether you want to use the rule type for defining rule based auto pay instructions or for defining business rules for mapping transactions with the price items. The valid value is: <ul style="list-style-type: none"> <li>Auto Pay</li> </ul> <div style="border: 1px solid black; padding: 5px; margin-top: 10px;"> <p><b>Note:</b> If you want to use the rule type for defining rule based auto pay instructions, you must set the rule type usage to <b>Auto Pay</b>. However, if you want to use the rule type for defining business rules for mapping transactions with the price items, you must leave this field blank.</p> </div>	No
Description	Used to specify the description for the rule type.	Yes
Maximum Rule Count	Used to indicate the maximum number of rules that can be defined when the rule based auto pay instruction is created using the rule type. <div style="border: 1px solid black; padding: 5px; margin-top: 10px;"> <p><b>Note:</b> This field appears only when you select the <b>Auto Pay</b> option from the <b>Rule Type Usage</b> list. The maximum rule count cannot be less than or equal to zero.</p> </div>	No

- Enter the required details in the **Main** section.
- Define, edit, or remove input or output parameters from the rule type, if required.
- Associate or remove one or more characteristic entities from the rule type, if required.

**Note:** You must specify at least one input or output parameter when you want to use the rule type for defining business rules for mapping transactions with the price items. However, you must specify at least one input or output parameter or associate at least one characteristic entity when you want to use the rule type for defining rule based auto pay instructions.

- Associate the rule criteria derivation algorithm when you want to use the rule type for defining rule based auto pay instructions.

**Note:** You must associate the rule criteria derivation algorithm with the rule type when the **Rule Type Usage** field is set to **Auto Pay**.

- Click **Save**.

The new rule type is defined.

### **Related Topics**

For more information on...	See...
How to search for a rule type	<a href="#">Searching for a Rule Type</a> on page 764
How to define input and output parameters for a rule type	<a href="#">Defining Input and Output Parameters for a Rule Type</a> on page 767
How to associate a characteristic entity with a rule type	<a href="#">Associating a Characteristic Entity with a Rule Type</a> on page 768

For more information on...	See...
How to associate an algorithm with a rule type	<a href="#">Associating an Algorithm with a Rule Type</a> on page 769

## Viewing the Rule Type Details

### Procedure

To view the details of a rule type:

1. Search for the rule type in the **Rule Type** screen.
2. In the **Search Results** section, click the **View** (🔍) icon in the **View** column corresponding to the rule type whose details you want to view.

The **Rule Type** screen appears.

3. View the details of the rule type in the **Rule Type** zone.

### Related Topics

For more information on...	See...
How to search for a rule type	<a href="#">Searching for a Rule Type</a> on page 764
<b>Rule Type</b> screen	<a href="#">Rule Type (Used for Viewing)</a> on page 775
<b>Rule Type</b> zone	<a href="#">Rule Type</a>

## Rule Type (Used for Viewing)

The **Rule Type** screen allows you to view the details of the rule type. It contains the following zone:

- [Rule Type](#) on page 775

### Rule Type

The **Rule Type** zone displays the details of the rule type. It contains the following sections:

- **Main** - Displays basic information about the rule type. It contains the following fields:

Field Name	Field Description
Rule Type	Displays the rule type.
Rule Type Usage	Indicates whether the rule type is used for defining rule based auto pay instructions or for defining business rules for mapping transactions with the price items.  <b>Note:</b> This field appears only when the rule type usage is specified while defining the rule type.
Description	Displays the description of the rule type.
Maximum Rule Count	Indicates the maximum number of rules that can be defined when the rule based auto pay instruction is created using the rule type.  <b>Note:</b> This field appears only when the <b>Rule Type Usage</b> field is set to <b>Auto Pay</b> .

- **Input and Output Parameters** - Lists the input and output parameters defined for the rule type. It contains the following columns:

Column Name	Column Description
Sequence	Displays the sequence number of the input or output parameter.
Field	Indicates the field which is used as the input or output parameter.
Type	Indicates whether the field is used as input and/or output parameter while defining a business rule.
Search Zone	Indicates the search zone that is used for searching the field value while defining criteria for rule based auto pay instructions.  <b>Note:</b> It has a link. On clicking the link, the <b>Zone</b> screen appears where you can view the details of the zone.

- **Rule Criteria Characteristic Entities** - This section contains the following column:

Column Name	Column Description
Characteristic Entity	Indicates the entity whose characteristics can be used while defining criteria for rule based auto pay instructions. The valid values are: <ul style="list-style-type: none"> <li>• Adjustment</li> <li>• Billable Charge</li> <li>• Policy</li> <li>• Policy Plan</li> <li>• Price Item</li> </ul>

- **Rule Criteria Derivation Algorithms** - Lists the algorithms attached to the rule type. It contains the following columns:

Column Name	Column Description
Sequence	Indicates the order in which the algorithm should be executed.
Algorithm	Indicates the algorithm attached to the rule type which derives the following from the financial transaction: <ul style="list-style-type: none"> <li>• Values of all those fields (such as, policy number, plan number, or price item) which are selected in the rule type as the input and output parameters</li> <li>• Characteristics of all those entities which are selected in the rule type as the rule criteria characteristic entities</li> </ul>

**Note:** The **Rule Criteria Characteristic Entities** and **Rule Criteria Derivation Algorithms** sections appear only when the **Rule Type Usage** field is set to **Auto Pay**.

You can edit the details of the rule type by clicking the **Edit** link in the upper-right corner of this zone.

### **Related Topics**

For more information on...	See...
How to edit a rule type	<a href="#">Editing a Rule Type</a> on page 770

## **Viewing the Rule Type Details**

### **Procedure**



To view the details of a rule type:

1. Search for the rule type in the **Rule Type** screen.
2. In the **Search Results** section, click the **View**  icon in the **View** column corresponding to the rule type whose details you want to view.

The **Rule Type** screen appears.

3. View the details of the rule type in the **Rule Type** zone.

### Related Topics

For more information on...	See...
How to search for a rule type	<a href="#">Searching for a Rule Type</a> on page 764
<b>Rule Type</b> screen	<a href="#">Rule Type (Used for Viewing)</a> on page 775
<b>Rule Type</b> zone	<a href="#">Rule Type</a>

## Editing a Rule Type

### Procedure

To edit a rule type:

1. Search for the rule type in the **Rule Type** screen.
2. In the **Search Results** section, click the **Edit**  icon in the **Edit** column corresponding to the rule type whose details you want to edit.

The **Rule Type** screen appears. It contains the following sections:

- **Main** - Used to specify basic details about the rule type.
- **Input and Output Parameters** - Used to define input and output parameters for the rule type.
- **Rule Criteria Characteristic Entities** - Used to indicate the entities whose characteristics you can use while defining rule based auto pay instructions using the rule type.

**Note:** This section appears only when you select the **Auto Pay** option from the **Rule Type Usage** list.

- **Rule Criteria Derivation Algorithms** - Used to attach algorithms which you want to use for deriving the following from the financial transaction:
  - Values of all those fields (such as, policy number, plan number, or price item) which are selected in the rule type as the input and output parameters
  - Characteristics of all those entities which are selected in the rule type as the rule criteria characteristic entities

**Note:** This section appears only when you select the **Auto Pay** option from the **Rule Type Usage** list.

The **Main** section contains the following fields:

Field Name	Field Description	Mandatory (Yes or No)
Rule Type	Displays the rule type.	Not applicable
Rule Type Usage	Indicates whether the rule type is used for defining rule based auto pay instructions or for defining business rules for mapping transactions with the price items.	Not applicable
Description	Used to specify the description for the rule type.	Yes

Field Name	Field Description	Mandatory (Yes or No)
Maximum Rule Count	<p>Used to indicate the maximum number of rules that can be defined when the rule based auto pay instruction is created using the rule type.</p> <p><b>Note:</b></p> <p>This field appears only when the <b>Rule Type Usage</b> field is set to <b>Auto Pay</b>.</p> <p>The maximum rule count cannot be less than or equal to zero.</p> <p>You cannot reduce the maximum rule count when one or more auto pay instructions contain the specified number of rules.</p>	No

**Tip:** Alternatively, you can edit the details of a rule type by clicking the **Edit** link in the **Rule Type** zone.

3. Modify the required details in the **Main** section.
4. Define, edit, or remove input or output parameters from the rule type, if required.

**Note:** You cannot edit or remove an input or output parameter from the rule type when it is used for defining criteria in a business rule or rule based auto pay instruction.

5. Associate or remove one or more characteristic entities from the rule type, if required.

**Note:**

You must specify at least one input or output parameter when you want to use the rule type for defining business rules for mapping transactions with the price items. However, you must specify at least one input or output parameter or associate at least one characteristic entity when you want to use the rule type for defining rule based auto pay instructions.

You cannot remove a characteristic entity from the rule type when it is used for defining criteria in a rule based auto pay instruction.

6. Associate or remove one or more rule criteria derivation algorithm from the rule type, if required.

**Note:** You must associate the rule criteria derivation algorithm with the rule type when the **Rule Type Usage** field is set to **Auto Pay**.

7. Click **Save**.

The changes made to the rule type are saved.

### **Related Topics**

For more information on...	See...
How to search for a rule type	<a href="#">Searching for a Rule Type</a> on page 764
How to define input and output parameters for a rule type	<a href="#">Defining Input and Output Parameters for a Rule Type</a> on page 767
How to associate a characteristic entity with a rule type	<a href="#">Associating a Characteristic Entity with a Rule Type</a> on page 768
How to associate an algorithm with a rule type	<a href="#">Associating an Algorithm with a Rule Type</a> on page 769

<b>For more information on...</b>	<b>See...</b>
<b>Rule Type zone</b>	<i>Rule Type</i> on page 775

## Rule

The **Rule** screen allows you to define, edit, delete, and copy a rule. This screen consists of the following zones:

- *Search* on page 779



## Search

The **Search** zone allows you to search for a rule. This zone contains the following two sections:

- **Search Criteria** — The **Search Criteria** section contains the following fields:

Field Name	Field Description	Mandatory (Yes or No)
Rule Code	Used to specify the rule code.	No
Rule Type	Used to specify the type of rule.	No
Description	Used to specify the description for the rule.	No
Rule Priority	Used to specify the priority of the rule.	No
Effective Start Date	Used to specify the date from when the rule is effective.	No

- **Search Results** — On clicking the **Search** button, the search results appear based on the specified search criteria. The **Search Results** section contains the following columns:

Column Name	Column Description
Priority	Displays the priority of the rule.
Code	Displays the rule code.
Description	Displays the description of the rule.
Type	Displays the type of rule.
Start Date	Displays the date from when the rule is effective.
End Date	Displays the date till when the rule is effective.
Preprocessing Algorithm	Indicates the algorithm that will be triggered before executing the criteria in the rule. It pre-processes the input parameters and then returns processed values against which the criteria is validated.
Postprocessing Algorithm	Indicates the algorithm that will be triggered when the rule is true. It post-processes the output parameters and returns the updated values to the calling programs or dependent rules.
View	On clicking the <b>View</b> (  ) icon, the <b>View Rule</b> screen appears where you can view the details of the rule.
Edit	On clicking the <b>Edit</b> (  ) icon, the <b>Edit Rule</b> screen appears where you can edit the details of the rule.

Column Name	Column Description
Delete	On clicking the <b>Delete</b> (🗑️) icon, you can delete the rule.  <b>Note:</b> You can delete a rule only if it is not used.
Copy	On clicking the <b>Copy</b> (📄) icon, the <b>Copy Rule</b> screen appears where you can create a rule using an existing rule.

You can create a new rule by clicking the **Add** link in the upper right corner of this zone.

### **Related Topics**

For more information on...	See...
How to search for a rule	<a href="#">Searching for a Rule</a> on page 780
How to view the details of a rule	<a href="#">Viewing the Rule Details</a> on page 781
How to define a rule	<a href="#">Defining a Rule</a> on page 781
How to edit a rule	<a href="#">Editing a Rule</a> on page 785
How to delete a rule	<a href="#">Deleting a Rule</a> on page 790
How to copy a rule	<a href="#">Copying a Rule</a> on page 790

## **Searching for a Rule**

### **Procedure**

To search for a rule:

1. Click the **Admin** link in the **Application** toolbar.  
A list appears.
2. From the **Admin** menu, select **R** and then click **Rule**.  
A sub-menu appears.
3. Click the **Search** option from the **Rule** sub-menu.  
The **Rule** screen appears.
4. Enter the search criteria in the **Search** zone.

**Note:** ORMB search engine supports wildcard search, where you can substitute the percentage (%) symbol as a stand in for any word or letter in a search criteria. You can use the ‘%’ wildcard character in all input fields except the date and ID fields. The ‘%’ wildcard character is suffixed automatically at the end of the partial search criteria. Therefore, you may or may not specify the wildcard character at the end of the partial search criteria. However, you have to prefix the wildcard character manually wherever required.

5. Click **Search**.  
A list of rules that meet the search criteria appears in the **Search Results** section.

### **Related Topics**

For more information on...	See...
<b>Rule</b> screen	<a href="#">Rule</a> on page 779
<b>Search</b> zone	<a href="#">Search</a> on page 779

## Viewing the Rule Details

### Procedure

To view the details of a rule:

1. Search for the rule in the **Rule** screen.
2. In the **Search Results** section, click the **View** () icon in the **View** column corresponding to the rule whose details you want to view.

The **View Rule** screen appears.

3. View the details of the rule in the **Rule Information** zone.

### Related Topics

For more information on...	See...
<b>View Rule</b> screen	<a href="#">View Rule</a> on page 791
<b>Rule Information</b> zone	<a href="#">Rule Information</a> on page 791
How to search for a rule	<a href="#">Searching for a Rule Type</a> on page 764

## Defining a Rule

### Prerequisites

To define a rule, you should have:

- Rule types defined in the application
- Preprocessing and postprocessing algorithms, dependent rules, and parameters defined in the application in case you want to use any of them

### Procedure

To define a rule:

1. Click the **Admin** link in the **Application** toolbar.  
A list appears.
2. From the **Admin** menu, select **R** and then click **Rule**.

A sub-menu appears.

3. Click the **Add** option from the **Rule** sub-menu.

The **Add Rule** screen appears. It contains the following fields:

Field Name	Field Description	Mandatory (Yes or No)
Rule Code	Used to specify the rule code.	Yes
Rule Type	Used to specify the type of rule.	Yes
Description	Used to specify the description for the rule.	Yes
Rule Priority	Used to specify the priority of the rule.  <b>Note:</b> You cannot define two rules with the same rule type and priority in the same duration.	Yes

Field Name	Field Description	Mandatory (Yes or No)
Effective Start Date	Used to specify the date from when the rule is effective.	Yes
Effective End Date	Used to specify the date till when the rule is effective.  <b>Note:</b> The effective end date cannot be earlier than the effective start date.	No
Preprocessing Algorithm	Used to specify the algorithm that will be triggered before executing the criteria in the rule. It pre-processes the input parameters and then returns processed values against which the criteria is validated.  <b>Note:</b> The <b>Search</b> (🔍) icon appears corresponding to this field. On clicking the <b>Search</b> icon, the <b>Algorithm Search</b> window appears.	No
Postprocessing Algorithm	Used to specify the algorithm that will be triggered when the rule is true. It post-processes the output parameters and returns the updated values to the calling programs or dependent rules.  <b>Note:</b> The <b>Search</b> (🔍) icon appears corresponding to this field. On clicking the <b>Search</b> icon, the <b>Algorithm Search</b> window appears.	No
Rule True Action	Used to indicate what should happen when all conditions in the rule are satisfied and returns <b>Rule is True</b> . The valid values are: <ul style="list-style-type: none"> <li>• <b>Next Dependent Rule</b> — Used to indicate that the dependent rule should be executed when the rule is true.</li> <li>• <b>Next Rule by Priority</b> — Used to indicate that the rule of the same rule type having lower priority should be executed when the rule is true.</li> <li>• <b>Success</b> — Used to indicate that no more rules should be executed when the rule is true. The output parameters and their values are returned to the calling programs.</li> </ul>	Yes
Dependent Rule	Used to specify the next dependent rule that must be executed when <b>Next Dependent Rule</b> is selected from the <b>Rule True Action</b> list.	Yes (Conditional)  <b>Note:</b> This field is required when you select <b>Next Dependent Rule</b> from the <b>Rule True Action</b> list.

Field Name	Field Description	Mandatory (Yes or No)
Rule False Action	Used to indicate what should happen when any of the criteria in the rule is not satisfied and returns <b>Rule is False</b> . The valid values are: <ul style="list-style-type: none"> <li>• <b>Next Dependent Rule</b> — Used to indicate that the dependent rule should be executed when the rule is false.</li> <li>• <b>Next Rule by Priority</b> — Used to indicate that the rule of the same rule type having lower priority should be executed when the rule is false.</li> <li>• <b>Success</b> — Used to indicate that no more rules should be executed when the rule is false. The output parameters and their values are returned to the calling programs.</li> </ul>	Yes
Dependent Rule	Used to specify the next dependent rule that must be executed when <b>Next Dependent Rule</b> is selected from the <b>Rule False Action</b> list.	Yes (Conditional)  <div style="border: 1px solid black; padding: 5px;"> <b>Note:</b> This field is required when you select <b>Next Dependent Rule</b> from the <b>Rule False Action</b> list. </div>

In addition, it contains the following two sections:

- **Rule Output Parameters** — Used to specify the output parameters that must be returned to the calling programs or dependent rules when all conditions in the rule are satisfied. This section contains the following columns:

Column Name	Column Description	Mandatory (Yes or No)
Parameter Name	Used to specify the parameter.  <div style="border: 1px solid black; padding: 5px;"> <b>Note:</b> For more information about the output parameters that you can specify while defining a rule, see <a href="#">Transaction Validation and Initial Price Item Determination</a>.   The <b>Search</b> (🔍) icon appears corresponding to this field. On clicking the <b>Search</b> icon, the <b>Search Rule Type Field</b> window appears. </div>	Yes
Parameter Value	Used to specify the value for the parameter.  <div style="border: 1px solid black; padding: 5px;"> <b>Note:</b> You can specify any special characters except ampersand (&amp;), comma (,), underscore (_), equal to (=), tilde (~), and semi-colon(;) in the parameter value. </div>	Yes

- **Criteria** — Used to define criteria for the rule. This section contains the following columns:

Column Name	Column Description	Mandatory (Yes or No)
Sequence Number	Used to indicate the order in which the criteria should be executed in the rule.	Yes

Column Name	Column Description	Mandatory (Yes or No)
Parameter Name	<p>Used to indicate whether you want to specify a field or an algorithm as an input parameter. It also allows you to specify the field or algorithm name.</p> <div style="border: 1px solid black; padding: 5px;"> <p><b>Note:</b> If a business label is defined for a user defined field (that you have selected), the business label appears in the <b>Parameter Name</b> field.</p> <p>The <b>Search</b> (🔍) icon appears corresponding to this field. On clicking the <b>Search</b> icon, the <b>Search Rule Type Field</b> window appears.</p> </div>	Yes
Operator	Used to specify the relational operator to define the relation between the parameter name and value.	Yes
Parameter Value	<p>Used to specify the parameter value.</p> <div style="border: 1px solid black; padding: 5px;"> <p><b>Note:</b> You can specify any special characters except ampersand (&amp;), comma (,), underscore (_), equal to (=), tilde (~), and semi-colon(;) in the parameter value.</p> <p>The <b>Search</b> (🔍) icon appears corresponding to this field. On clicking the <b>Search</b> icon, the <b>Search Rule Type Field</b> window appears.</p> </div>	Yes
Is True	<p>Used to indicate what should happen when the condition is true (satisfied). The valid values are:</p> <ul style="list-style-type: none"> <li>• <b>Check next condition</b> — Used to indicate that the condition with consecutive sequence number should be executed.</li> <li>• <b>Rule is false</b> — Used to indicate that the action specified in the <b>Rule False Action</b> field should be executed.</li> <li>• <b>Rule is true</b> — Used to indicate that the action specified in the <b>Rule True Action</b> field should be executed.</li> </ul>	Yes
Is False	<p>Used to indicate what should happen when the condition is false (not satisfied). The valid values are:</p> <ul style="list-style-type: none"> <li>• <b>Check next condition</b> — Used to indicate that the condition with consecutive sequence number should be executed.</li> <li>• <b>Rule is false</b> — Used to indicate that the action specified in the <b>Rule False Action</b> field should be executed.</li> <li>• <b>Rule is true</b> — Used to indicate that the action specified in the <b>Rule True Action</b> field should be executed.</li> </ul>	Yes



Column Name	Column Description	Mandatory (Yes or No)
Is Insufficient	Used to indicate what should happen when the data is insufficient. The valid values are: <ul style="list-style-type: none"> <li>• <b>Check next condition</b> — Used to indicate that the condition with consecutive sequence number should be executed.</li> <li>• <b>Rule is false</b> — Used to indicate that the action specified in the <b>Rule False Action</b> field should be executed.</li> <li>• <b>Rule is true</b> — Used to indicate that the action specified in the <b>Rule True Action</b> field should be executed.</li> </ul>	Yes

**Tip:** Alternatively, you can access the **Add Rule** screen by clicking the **Add** link in the upper right corner of the **Search** zone in the **Rule** screen.

4. Enter the required details.

**Note:**

You can search for a parameter, dependent rule and an algorithm by clicking the **Search** (🔍) icon corresponding to the respective field.

If you want to associate more than one output parameter with the rule or define more than one criteria for the rule, click the **Add** (+) icon and then specify the details. However, if you want to remove an output parameter or a criteria from the rule, click the **Delete** (🗑️) icon corresponding to it.

5. Click **Save**.

The rule is defined.

### **Related Topics**

For more information on...	See...
<b>Rule</b> screen	<a href="#">Rule</a> on page 779
<b>Search</b> zone	<a href="#">Search</a> on page 779

## **Editing a Rule**

### **Prerequisites**

To edit a rule, you should have:

- Preprocessing and postprocessing algorithms, dependent rules, and parameters defined in the application in case you want to use any of them.

### **Procedure**

To edit a rule:

1. Search for the rule in the **Rule** screen.
2. In the **Search Results** section, click the **Edit** (✎) icon in the **Edit** column corresponding to the rule whose details you want to edit.

The **Edit Rule** screen appears. It contains the following fields:

Field Name	Field Description	Mandatory (Yes or No)
Rule Code	Used to specify the rule code.	Yes
Rule Type	Used to specify the type of rule.	Yes
Description	Used to specify the description for the rule.	Yes
Rule Priority	Used to specify the priority of the rule.  <b>Note:</b> You cannot define two rules with the same rule type and priority in the same duration.	Yes
Effective Start Date	Used to specify the date from when the rule is effective.	Yes
Effective End Date	Used to specify the date till when the rule is effective.  <b>Note:</b> The effective end date cannot be earlier than the effective start date.	No
Preprocessing Algorithm	Used to specify the algorithm that will be triggered before executing the criteria in the rule. It pre-processes the input parameters and then returns processed values against which the criteria is validated.  <b>Note:</b> The <b>Search</b> (🔍) icon appears corresponding to this field. On clicking the <b>Search</b> icon, the <b>Algorithm Search</b> window appears.	No
Postprocessing Algorithm	Used to specify the algorithm that will be triggered when the rule is true. It post-processes the output parameters and returns the updated values to the calling programs or dependent rules.  <b>Note:</b> The <b>Search</b> (🔍) icon appears corresponding to this field. On clicking the <b>Search</b> icon, the <b>Algorithm Search</b> window appears.	No

Field Name	Field Description	Mandatory (Yes or No)
Rule True Action	Used to indicate what should happen when all conditions in the rule are satisfied and returns <b>Rule is True</b> . The valid values are: <ul style="list-style-type: none"> <li>• <b>Next Dependent Rule</b> — Used to indicate that the dependent rule should be executed when the rule is true.</li> <li>• <b>Next Rule by Priority</b> — Used to indicate that the rule of the same rule type having lower priority should be executed when the rule is true.</li> <li>• <b>Success</b> — Used to indicate that no more rules should be executed when the rule is true. The output parameters and their values are returned to the calling programs.</li> </ul>	Yes
Dependent Rule	Used to specify the next dependent rule that must be executed when <b>Next Dependent Rule</b> is selected from the <b>Rule True Action</b> list.	Yes (Conditional) <div style="border: 1px solid black; padding: 5px; margin-top: 5px;"> <b>Note:</b> This field is required when you select <b>Next Dependent Rule</b> from the <b>Rule True Action</b> list. </div>
Rule False Action	Used to indicate what should happen when any of the criteria in the rule is not satisfied and returns <b>Rule is False</b> . The valid values are: <ul style="list-style-type: none"> <li>• <b>Next Dependent Rule</b> — Used to indicate that the dependent rule should be executed when the rule is false.</li> <li>• <b>Next Rule by Priority</b> — Used to indicate that the rule of the same rule type having lower priority should be executed when the rule is false.</li> <li>• <b>Success</b> — Used to indicate that no more rules should be executed when the rule is false. The output parameters and their values are returned to the calling programs.</li> </ul>	Yes
Dependent Rule	Used to specify the next dependent rule that must be executed when <b>Next Dependent Rule</b> is selected from the <b>Rule False Action</b> list.	Yes (Conditional) <div style="border: 1px solid black; padding: 5px; margin-top: 5px;"> <b>Note:</b> This field is required when you select <b>Next Dependent Rule</b> from the <b>Rule False Action</b> list. </div>

In addition, it contains the following two sections:

- **Rule Output Parameters** — Used to specify the output parameters that must be returned to the calling programs or dependent rules when all conditions in the rule are satisfied. This section contains the following columns:

Column Name	Column Description	Mandatory (Yes or No)
Parameter Name	<p>Used to specify the parameter.</p> <p><b>Note:</b> For more information about the output parameters that you can specify while defining a rule, see <a href="#">Transaction Validation and Initial Price Item Determination</a>.</p> <p>The <b>Search</b> (🔍) icon appears corresponding to this field. On clicking the <b>Search</b> icon, the <b>Search Rule Type Field</b> window appears.</p>	Yes
Parameter Value	<p>Used to specify the value for the parameter.</p> <p><b>Note:</b> You can specify any special characters except ampersand (&amp;), comma (,), underscore (_), equal to (=), tilde (~), and semi-colon(;) in the parameter value.</p>	Yes

- **Criteria** — Used to define criteria for the rule. This section contains the following columns:

Column Name	Column Description	Mandatory (Yes or No)
Sequence Number	Used to indicate the order in which the criteria should be executed in the rule.	Yes
Parameter Name	<p>Used to indicate whether you want to specify a field or an algorithm as an input parameter. It also allows you to specify the field or algorithm name.</p> <p><b>Note:</b></p> <p>If a business label is defined for a user defined field (that you have selected), the business label appears in the <b>Parameter Name</b> field.</p> <p>The <b>Search</b> (🔍) icon appears corresponding to this field. On clicking the <b>Search</b> icon, the <b>Search Rule Type Field</b> window appears.</p>	Yes
Operator	Used to specify the relational operator to define the relation between the parameter name and value.	Yes
Parameter Value	<p>Used to specify the parameter value.</p> <p><b>Note:</b> You can specify any special characters except ampersand (&amp;), comma (,), underscore (_), equal to (=), tilde (~), and semi-colon(;) in the parameter value.</p> <p>The <b>Search</b> (🔍) icon appears corresponding to this field. On clicking the <b>Search</b> icon, the <b>Search Rule Type Field</b> window appears.</p>	Yes

Column Name	Column Description	Mandatory (Yes or No)
Is True	Used to indicate what should happen when the condition is true (satisfied). The valid values are: <ul style="list-style-type: none"> <li>• <b>Check next condition</b> — Used to indicate that the condition with consecutive sequence number should be executed.</li> <li>• <b>Rule is false</b> — Used to indicate that the action specified in the <b>Rule False Action</b> field should be executed.</li> <li>• <b>Rule is true</b> — Used to indicate that the action specified in the <b>Rule True Action</b> field should be executed.</li> </ul>	Yes
Is False	Used to indicate what should happen when the condition is false (not satisfied). The valid values are: <ul style="list-style-type: none"> <li>• <b>Check next condition</b> — Used to indicate that the condition with consecutive sequence number should be executed.</li> <li>• <b>Rule is false</b> — Used to indicate that the action specified in the <b>Rule False Action</b> field should be executed.</li> <li>• <b>Rule is true</b> — Used to indicate that the action specified in the <b>Rule True Action</b> field should be executed.</li> </ul>	Yes
Is Insufficient	Used to indicate what should happen when the data is insufficient. The valid values are: <ul style="list-style-type: none"> <li>• <b>Check next condition</b> — Used to indicate that the condition with consecutive sequence number should be executed.</li> <li>• <b>Rule is false</b> — Used to indicate that the action specified in the <b>Rule False Action</b> field should be executed.</li> <li>• <b>Rule is true</b> — Used to indicate that the action specified in the <b>Rule True Action</b> field should be executed.</li> </ul>	Yes

**Tip:** Alternatively, you can access the **Edit Rule** screen by clicking the **Edit** link in the **View Rule** screen.

3. Modify the required details.

**Note:** You can search for a parameter, dependent rule and an algorithm by clicking the **Search** (🔍) icon corresponding to the respective field.

4. Add or remove output parameters or criteria from the rule, if required.

**Note:** If you want to associate more than one output parameter with the rule or define more than one criteria for the rule, click the **Add** (+) icon and then specify the details. However, if you want to remove an output parameter or a criteria from the rule, click the **Delete** (🗑️) icon corresponding to it.

5. Click **Save**.

The changes made to the rule are saved.

### Related Topics

For more information on...	See...
<b>Rule</b> screen	<a href="#">Rule</a> on page 779
<b>Search</b> zone	<a href="#">Search</a> on page 779

## Deleting a Rule

### Procedure

To delete a rule:

1. Search for the rule in the **Rule** screen.
2. In the **Search Results** section, click the **Delete** (🗑️) icon in the **Delete** column corresponding to the rule that you want to delete.

A message appears confirming whether you want to delete the rule.

**Note:** You can delete a rule only if it is not used.

3. Click **OK**.

The rule is deleted.

### Related Topics

For more information on...	See...
<b>Rule</b> screen	<a href="#">Rule</a> on page 779
<b>Search</b> zone	<a href="#">Search</a> on page 779

## Copying a Rule

Instead of creating a rule from scratch, you can also create a new rule using an existing rule. You can do this by copying a rule. When you copy a rule, the output parameters and criteria defined for the original rule are copied to the new rule. You can then add or remove parameters or criteria from the new rule.

### Prerequisites

To copy a rule, you should have:

- Rule (whose copy you want to create) defined in the application
- Preprocessing and postprocessing algorithms, dependent rules, and parameters defined in the application in case you want to use any of them

### Procedure

To copy a rule:

1. Search for the rule in the **Rule** screen.
2. In the **Search Results** section, click the **Copy** (📄) icon corresponding to the rule whose copy you want to create.

The **Copy Rule** screen appears.

3. Enter the new rule code and the description for the new rule.

4. Modify the required details.
5. Add or remove output parameters or criteria from the new rule.

**Note:**

You can specify any special characters except ampersand (&), comma (,), underscore (\_), equal to (=), tilde (~), and semi-colon(;) in the parameter value.

You can search for a parameter, dependent rule and an algorithm by clicking the **Search** (🔍) icon corresponding to the respective field.

If you want to associate more than one output parameter with the rule or define more than one criteria for the rule, click the **Add** (+) icon and then specify the details. However, if you want to remove an output parameter or a criteria from the rule, click the **Delete** (🗑️) icon corresponding to it.

For more information about the output parameters that you can specify while defining a rule, see [Transaction Validation and Initial Price Item Determination](#).

6. Click **Save**.

The new rule is defined.

**Related Topics**

For more information on...	See...
<b>Rule</b> screen	<a href="#">Rule</a> on page 779
<b>Search</b> zone	<a href="#">Search</a> on page 779
How to define a rule	<a href="#">Defining a Rule</a> on page 781

## View Rule

The **View Rule** screen allows you to view the details of a rule. This screen consists of the following zones:

- [Rule Information](#) on page 791

### Rule Information

The **Rule Information** zone displays information about the rule. This zone contains the following fields:

Field Name	Field Description
Rule Code	Displays the rule code.
Rule Type	Indicates the type of rule.
Description	Displays the description of the rule.
Rule Priority	Indicates the priority of the rule.  <b>Note:</b> You can use the <b>Move Up</b> (↑) and <b>Move Down</b> (↓) icons corresponding to this field to view the details of a rule (having the same rule type) with a higher or lower priority. Note that this functionality is available only when you access the <b>View Rule</b> screen through the <b>Rule</b> screen.
Effective Start Date	Displays the date from when the rule is effective.

Field Name	Field Description
Effective End Date	Displays the date till when the rule is effective.
Preprocessing Algorithm	Indicates the algorithm that will be triggered before executing the criteria in the rule. It pre-processes the input parameters and then returns processed values against which the criteria is validated.
Postprocessing Algorithm	Indicates the algorithm that will be triggered after executing the criteria in the rule. It post-processes the output parameters and returns the updated values to the calling programs or dependent rules.
Rule True Action	Indicates what should happen when all conditions in the rule are satisfied and returns <b>Rule is True</b> .
Dependent Rule	Indicates the next dependent rule that must be executed when <b>Next Dependent Rule</b> is selected from the <b>Rule True Action</b> list.
Rule False Action	Indicates what should happen when any of the criteria in the rule is not satisfied and returns <b>Rule is False</b> .
Dependent Rule	Indicates the next dependent rule that must be executed when <b>Next Dependent Rule</b> is selected from the <b>Rule False Action</b> list.

In addition, it contains the following two sections:

- **Rule Output Parameters** — Lists the output parameters that must be returned to the calling programs or dependent rules when all conditions in the rule are satisfied. This section contains the following columns:

Column Name	Column Description
Parameter Name	Displays the name of the parameter. In addition, this column has a context menu which helps in navigating to the <b>Field</b> screen.
Parameter Value	Displays the value of the parameter.

- **Criteria** — Lists the criteria defined in the rule. This section contains the following columns:

Column Name	Column Description
Sequence Number	Indicates the order in which the criteria should be executed in the rule.
Parameter Type	Indicates whether the input parameter is a field or an algorithm.
Parameter Name	Displays the field or algorithm name which is used as an input parameter.
Operator	Indicates the relational operator used to define the relation between the parameter name and value.
Parameter Value	Displays the parameter value.
Is True	Indicates what should happen when the condition is true (satisfied). The valid values are: <ul style="list-style-type: none"> <li>• <b>Check next condition</b> — Indicates that the condition with consecutive sequence number should be executed.</li> <li>• <b>Rule is false</b> — Indicates that the action specified in the <b>Rule False Action</b> field should be executed.</li> <li>• <b>Rule is true</b> — Indicates that the action specified in the <b>Rule True Action</b> field should be executed.</li> </ul>



Column Name	Column Description
Is False	<p>Indicates what should happen when the condition is false (not satisfied). The valid values are:</p> <ul style="list-style-type: none"> <li>• <b>Check next condition</b> — Indicates that the condition with consecutive sequence number should be executed.</li> <li>• <b>Rule is false</b> — Indicates that the action specified in the <b>Rule False Action</b> field should be executed.</li> <li>• <b>Rule is true</b> — Indicates that the action specified in the <b>Rule True Action</b> field should be executed.</li> </ul>
Is Insufficient	<p>Indicates what should happen when the data is insufficient. The valid values are:</p> <ul style="list-style-type: none"> <li>• <b>Check next condition</b> — Indicates that the condition with consecutive sequence number should be executed.</li> <li>• <b>Rule is false</b> — Indicates that the action specified in the <b>Rule False Action</b> field should be executed.</li> <li>• <b>Rule is true</b> — Indicates that the action specified in the <b>Rule True Action</b> field should be executed.</li> </ul>

The **Edit** link appears in the upper-right corner of the **Rule Information** zone. On clicking the **Edit** link, the **Edit Rule** screen appears where you can edit the details of the rule.

### Related Topics

For more information on...	See...
How to view the details of a rule	<a href="#">Viewing the Rule Details</a> on page 781

## Viewing the Rule Details

### Procedure

To view the details of a rule:

1. Search for the rule in the **Rule** screen.
2. In the **Search Results** section, click the **View** () icon in the **View** column corresponding to the rule whose details you want to view.

The **View Rule** screen appears.

3. View the details of the rule in the **Rule Information** zone.

### Related Topics

For more information on...	See...
<b>View Rule</b> screen	<a href="#">View Rule</a> on page 791
<b>Rule Information</b> zone	<a href="#">Rule Information</a> on page 791
How to search for a rule	<a href="#">Searching for a Rule Type</a> on page 764

## Rule Check

The **Rule Check** screen allows you to validate whether rules of a particular rule type are executed as expected. On validating, it indicates the sequence in which all effective rules were executed, the total execution time, and the output parameters of the rule that was successfully executed. This screen consists of the following sections:

- Rule Type Input Parameters
- Rule Output Parameters
- Rule Execution

### Rule Type Input Parameters

The **Rule Type Input Parameters** section contains the following fields:

Field Name	Field Description	Mandatory (Yes or No)
Rule Type	Used to specify the rule type.	Yes
Effective Date	Used when you want to execute the rules which are effective on a particular date.  <b>Note:</b> If you do not specify the effective date, the system executes all rules which are effective on the system date.	No
Parameter Name	Indicates the input parameter.  <b>Note:</b> The input parameters listed change depending on the rule type that you have selected.	Not applicable
Parameter Value	Used to specify the value for the input parameter.	Yes

In addition, this section contains the **Check Rule** button. On clicking the button, you can validate the sequence in which the rules with the specified rule type are executed.

### Rule Output Parameters

The **Rule Output Parameters** section contains the following fields:

Field Name	Field Description
Status	Displays the status of the rule execution. The valid values are: <ul style="list-style-type: none"> <li>• <b>Success</b> — Indicates that one of the rule was successfully executed and returned the output parameters.</li> <li>• <b>Fail</b> — Indicates that none of the rules with the specified rule type were successfully executed.</li> <li>• <b>Error</b> — Indicates that an error occurred while executing a rule.</li> </ul>
Execution Time	Displays the total time taken to execute all effective rules with the specified rule type.
Error	Displays the error message indicating the error that occurred while executing a rule.  <b>Note:</b> This field appears only when the status is <b>Error</b> .

In addition, this section contains the following columns:

Column Name	Column Description
Parameter Name	Displays the output parameter of the rule that was successfully executed.
Parameter Value	Displays the value of the output parameter.

### **Rule Execution**

The **Rule Execution** section indicates the sequence in which all effective rules with the specified rule type were executed. This section contains the following columns:

Column Name	Column Description
Rule Code	Indicates the rule that was executed.
Rule Type	Indicates the type of rule.
Rule Priority	Indicates the priority of the rule.
Rule Status Flag	Indicates whether the rule was true or false.
Rule Next Action	Indicates the action that took place when the rule was true or false.

### **Rule Check**

The **Rule Check** zone allows you to validate whether rules of a particular rule type are executed as expected. It indicates the sequence in which all effective rules were executed along with the total execution time. This zone consists of the following sections:

- **Rule Type Input Parameters** — This sections contains the following fields:

Field Name	Field Description	Mandatory (Yes or No)
Rule Type	Used to specify the rule type.	Yes
Effective Date	Used when you want to execute the rules which are effective on a particular date.	No
Parameter Name	Indicates the input parameter. <b>Note:</b> The input parameters listed change depending on the rule type that you have selected.	Not applicable
Parameter Value	Used to specify the value for the input parameter.	Yes

In addition, this section contains the **Check Rule** button. On clicking the button, you can validate the sequence in which the rules with the specified rule type are executed.

- **Rule Output Parameters** — This section contains the following fields:

Field Name	Field Description
Status	Displays the status of the rule execution. The valid values are: <ul style="list-style-type: none"> <li>• <b>Success</b> — Indicates that one of the rule was successfully executed and returned the output parameters.</li> <li>• <b>Fail</b> — Indicates that none of the rules with the specified rule type were successfully executed.</li> <li>• <b>Error</b> — Indicates that an error occurred while executing a rule.</li> </ul>
Execution Time	Displays the total time taken to execute a set of rules.

Field Name	Field Description
Error	Displays the error message indicating the error that occurred while executing a rule. <b>Note:</b> This field appears only when the status is <b>Error</b> .

In addition, this section contains the following columns:

Column Name	Column Description
Parameter Name	Displays the output parameter of the rule that was successfully executed.
Parameter Value	Displays the value of the output parameter.

- **Rule Execution** — Indicates the sequence in which the rules with the specified rule type were executed. This section contains the following columns:

Column Name	Column Description
Rule Code	Displays the rule code.
Rule Type	Displays the type of rule.
Rule Priority	Displays the priority of the rule.
Rule Status Flag	Indicates whether the rule was true or false.
Rule Next Action	Indicates the action that took place when the rule was true or false.

#### **Related Topics**

For more information on...	See...
<b>Rule Check</b> screen	<a href="#">Rule Check</a> on page 794

---

# Chapter 9

---

## Alternate Sequential Bill Numbers

---

### Topics:

- [Sequential Bill Number Generation Algorithms](#)
- [Enabling the Alternate Sequential Bill Numbers Feature](#)

Each bill is uniquely identified by its bill ID. Bill ID is a random, system-generated number. In some locales, bills have an additional identifier known as alternate sequential bill number. Alternate sequential bill numbers are system-generated, sequential numbers. For example, the first bill generated by the system is assigned a sequential bill number of 1, the next bill is assigned a value of 2, and so on.

If you want to generate alternate sequential bill numbers, you must select the **Use Sequential Bill Numbers** check box in the **Billing** tab of the **Installation Options** screen. However, you can only generate alternate sequential bill numbers for bills that are complete and for which the alternate sequential bill numbers are not yet generated.

You can configure the application to generate alternate sequential bill numbers which are either unique throughout the system or within the division. The **Assign Sequential Bill Numbers (ASSGNSBN)** batch allows you to generate alternate sequential bill numbers for completed bills. You need to configure this batch such that it is executed at regular intervals. For more information about the batch, refer to *Oracle Revenue Management and Billing Batch Guide*.

## Sequential Bill Number Generation Algorithms

The following table lists the sequential bill number generation algorithm types shipped with the product:

If you want to generate...	Then create algorithm using the following algorithm type....
Alternate sequential bill numbers unique throughout the system	<a href="#">C1_ALTBLLSYS</a> on page 798
Alternate sequential bill numbers unique within the division	<a href="#">C1_ALTBLDV</a> on page 801
Alternate sequential bill numbers unique throughout the system and in the required format using a set of parameters	<a href="#">C1_ALTBSYSI</a> on page 798 <b>Note:</b> The alternate sequential bill number will be unique throughout the system only when you configure the algorithm parameters appropriately.
Alternate sequential bill numbers unique within the division and in the required format using a set of parameters	<a href="#">C1_ALTBLDIVI</a> on page 801 <b>Note:</b> The alternate sequential bill number will be unique within the division only when you configure the algorithm parameters appropriately.

### C1\_ALTBLLSYS

The **C1\_ALTBLLSYS** algorithm type is used to generate alternate bill ID for a completed bill. The alternate bill ID is sequenced using the sequence number, and is unique throughout the system. This algorithm type does not have any parameters.

### C1\_ALTBSYSI

The **C1\_ALTBSYSI** algorithm type is used to generate alternate bill ID for a completed bill. You can generate alternate bill ID in the required format using the following parameters:

Parameter	Description
'X'	Here, X stands for a separator. For example, ','. The separator must be enclosed within single quotes. It will act as a delimiter in the alternate sequential bill number.
CIS_DIVISION	The division to which the account belongs. It is retrieved from the bill. It should not be more than five characters.
BILL_CYC_CD	The bill cycle of the account for which the bill is generated. It is retrieved from the bill. It should not be more than four characters.

Parameter	Description
ACCT_IDENTIFIER=<Account_Identifier_Type>,<CharStartPosition>,<CharCount>	<p>Here, you need to specify the following information separated by a comma:</p> <ul style="list-style-type: none"> <li>• <b>&lt;Account_Identifier_Type&gt;</b> - Used to indicate the account identifier type whose value must be used to generate the alternate sequential bill number.</li> <li>• <b>&lt;CharStartPosition&gt;</b> - Used to indicate the starting position from where you want to extract the characters from the account identifier. If you do not specify the starting position, by default, it is set to zero (0) (i.e. from the first character).</li> <li>• <b>&lt;CharCount&gt;</b> - Used to indicate the number of characters that you want to extract from the account identifier. If you do not specify the count, by default, it is set to five.</li> </ul>
CHARACC=<Characteristic_Type>,<CharStartPosition>,<CharCount>	<p>Here, you need to specify the following information separated by a comma:</p> <ul style="list-style-type: none"> <li>• <b>&lt;Characteristic_Type&gt;</b> - Used to indicate the account's characteristic whose value must be used to generate the alternate sequential bill number.</li> <li>• <b>&lt;CharStartPosition&gt;</b> - Used to indicate the starting position from where you want to extract the characters from the characteristic value. If you do not specify the starting position, by default, it is set to zero (0) (i.e. from the first character).</li> <li>• <b>&lt;CharCount&gt;</b> - Used to indicate the number of characters that you want to extract from the characteristic value. If you do not specify the count, by default, it is set to five.</li> </ul> <div data-bbox="820 1241 1463 1350" style="border: 1px solid black; padding: 5px;"> <p><b>Note:</b> If the same characteristic is defined multiple times for an account, the characteristic value which is effective on the batch business date is considered.</p> </div>

Parameter	Description
CHARPER=<Characteristic_Type>,<CharStartPosition>,<CharCount>	<p>Here, you need to specify the following information separated by a comma:</p> <ul style="list-style-type: none"> <li>• <b>&lt;Characteristic_Type&gt;</b> - Used to indicate the person's characteristic whose value must be used to generate the alternate sequential bill number.</li> <li>• <b>&lt;CharStartPosition&gt;</b> - Used to indicate the starting position from where you want to extract the characters from the characteristic value. If you do not specify the starting position, by default, it is set to zero (0) (i.e. from the first character).</li> <li>• <b>&lt;CharCount&gt;</b> - Used to indicate the number of characters that you want to extract from the characteristic value. If you do not specify the count, by default, it is set to five.</li> </ul> <p><b>Note:</b> If the same characteristic is defined multiple times for an account, the characteristic value which is effective on the batch business date is considered.</p>
BILL_DT=MMddy	<p>The date when the bill is created for the account. It should not be more than six characters. You can use the following patterns in the date format:</p> <ul style="list-style-type: none"> <li>• "yyyy" or "yy" for year</li> <li>• "MM" or "M" for month</li> <li>• "dd" or "d" for day</li> </ul> <p><b>Note:</b> The date format should either start or end with the year.</p>
SEQ_NBR	The sequence number generated by the database. It should not be more than 12 characters.
FIXED_SUFFIX=XX	Here, X stands for a letter or a group of letters that you want to add at the end of the alternate sequential bill number.
LEFT_PADDING_CHAR=ZERO LEFT_PADDING_CHAR=SPACE	<p>or</p> <p>Indicates whether you want to add zero or space when the number of characters derived from the account's or person's characteristic value is less than the character count. The padding is added to the left.</p>

You can specify the above mentioned parameters against any of the following parameters available in the C1\_ALTBLSYS1 algorithm type:

- Field1
- Field2
- Field3
- Field4
- Field5
- Field6
- Field7



- Field8
- Field9
- Field10

None of these algorithm type parameters are mandatory. The system will concatenate the parameter values and then generate alternate bill ID in the required format. For example, if you created the algorithm using the following parameters:

- Field1 — CIS\_DIVISION
- Field2 — ‘|’
- Field3 — SEQ\_NBR
- Field4 — ‘-’
- Field5 — FIXED\_SUFFIX=01

In this case, the system will generate the alternate bill ID in the CIS\_DIVISION|SEQ\_NBR-01 format. For example, DIV1|12345678-01. If you want to generate unique alternate bill ID, we recommend you to use the **SEQ\_NBR** parameter while creating an algorithm using the **C1\_ALTBLSYS1** algorithm type.

Note that if you do not specify the value for any parameters while creating an algorithm using the **C1\_ALTBLSYS1** algorithm type, the system will generate the alternate bill ID using the sequence number.

While specifying the value for these parameters, you need to ensure that the length of the alternate bill ID should not exceed 30 characters. An algorithm named **C1\_ALTBLSYS1** is already shipped with the product. You can create custom algorithms using the **C1\_ALTBLSYS1** algorithm type to design the required alternate bill ID format using the above mentioned parameters.

## C1\_ALTBLDV

The **C1\_ALTBLDV** algorithm type is used to generate alternate bill ID for a completed bill which is unique within the division. For example, two bills (such as B1 and B2) belonging to the same division (such as D1) cannot have the same alternate bill ID. However, two bills (such as B1 and B2) belonging to different divisions, (such as D1 and D2) can have the same alternate bill ID.

This algorithm type contains the following parameters:

Parameter	Description	Mandatory (Yes or No)
Initial Bill Sequence Number	Used to specify the initial alternate bill ID that you want to use while sequencing.  <b>Note:</b> If you do not specify any value for this parameter, by default, the system will generate the initial alternate bill ID for sequencing.	No

## C1\_ALTBLDIV1

The **C1\_ALTBLDIV1** algorithm type is used to generate alternate bill ID for a completed bill. You can generate alternate bill ID in the required format using the following parameters:

Parameter	Description
‘X’	Here, X stands for a separator. For example, ‘;’. The separator must be enclosed within single quotes. It will act as a delimiter in the alternate sequential bill number.
CIS_DIVISION	The division to which the account belongs. It is retrieved from the bill. It should not be more than five characters.

Parameter	Description
BILL_CYC_CD	The bill cycle of the account for which the bill is generated. It is retrieved from the bill. It should not be more than four characters.
ACCT_IDENTIFIER=<Account_Identifier_Type>,<CharStartPosition>,<CharCount>	<p>Here, you need to specify the following information separated by a comma:</p> <ul style="list-style-type: none"> <li>• <b>&lt;Account_Identifier_Type&gt;</b> - Used to indicate the account identifier type whose value must be used to generate the alternate sequential bill number.</li> <li>• <b>&lt;CharStartPosition&gt;</b> - Used to indicate the starting position from where you want to extract the characters from the account identifier. If you do not specify the starting position, by default, it is set to zero (0) (i.e. from the first character).</li> <li>• <b>&lt;CharCount&gt;</b> - Used to indicate the number of characters that you want to extract from the account identifier. If you do not specify the count, by default, it is set to five.</li> </ul>
CHARACC=<Characteristic_Type>,<CharStartPosition>,<CharCount>	<p>Here, you need to specify the following information separated by a comma:</p> <ul style="list-style-type: none"> <li>• <b>&lt;Characteristic_Type&gt;</b> - Used to indicate the account's characteristic whose value must be used to generate the alternate sequential bill number.</li> <li>• <b>&lt;CharStartPosition&gt;</b> - Used to indicate the starting position from where you want to extract the characters from the characteristic value. If you do not specify the starting position, by default, it is set to zero (0) (i.e. from the first character).</li> <li>• <b>&lt;CharCount&gt;</b> - Used to indicate the number of characters that you want to extract from the characteristic value. If you do not specify the count, by default, it is set to five.</li> </ul> <div style="border: 1px solid black; padding: 5px; margin-top: 10px;"> <p><b>Note:</b> If the same characteristic is defined multiple times for an account, the characteristic value which is effective on the batch business date is considered.</p> </div>

Parameter	Description
CHARPER=<Characteristic_Type>,<CharStartPosition>,<CharCount>	<p>Here, you need to specify the following information separated by a comma:</p> <ul style="list-style-type: none"> <li>• <b>&lt;Characteristic_Type&gt;</b> - Used to indicate the person's characteristic whose value must be used to generate the alternate sequential bill number.</li> <li>• <b>&lt;CharStartPosition&gt;</b> - Used to indicate the starting position from where you want to extract the characters from the characteristic value. If you do not specify the starting position, by default, it is set to zero (0) (i.e. from the first character).</li> <li>• <b>&lt;CharCount&gt;</b> - Used to indicate the number of characters that you want to extract from the characteristic value. If you do not specify the count, by default, it is set to five.</li> </ul> <p><b>Note:</b> If the same characteristic is defined multiple times for an account, the characteristic value which is effective on the batch business date is considered.</p>
BILL_DT=MMddy	<p>The date when the bill is created for the account. It should not be more than six characters. You can use the following patterns in the date format:</p> <ul style="list-style-type: none"> <li>• "yyyy" or "yy" for year</li> <li>• "MM" or "M" for month</li> <li>• "dd" or "d" for day</li> </ul> <p><b>Note:</b> The date format should either start or end with the year.</p>
FIXED_SUFFIX=XX	<p>Here, X stands for a letter or a group of letters that you want to add at the end of the alternate sequential bill number.</p>
LEFT_PADDING_CHAR=ZERO LEFT_PADDING_CHAR=SPACE	<p>or</p> <p>Indicates whether you want to add zero or space when the number of characters derived from the account's or person's characteristic value is less than the character count. The padding is added to the left.</p>

You can specify the above mentioned parameters against any of the following parameters available in the C1\_ALTBLDIV1 algorithm type:

- Field1
- Field2
- Field3
- Field4
- Field5
- Field6
- Field7
- Field8
- Field9

- Field10

None of these algorithm type parameters are mandatory. The system will concatenate the parameter values and then generate alternate bill ID in the required format. For example, if you created the algorithm using the following parameters:

- Field1 — CIS\_DIVISION
- Field2 — ‘|’
- Field3 — BILL\_DT=MMddy
- Field4 — ‘-’
- Field5 — FIXED\_SUFFIX=01

In this case, the system will generate the alternate bill ID in the CIS\_DIVISION|MMddy-01 format. For example, DIV1|110501-01. Note that if you do not specify the value for any of these algorithm type parameters, the system will not generate the alternate bill ID for a completed bill.

While specifying the value for these parameters, you need to ensure that the length of the alternate bill ID should not exceed 30 characters. An algorithm named **C1\_ALTBLDIV1** is already shipped with the product. You can create custom algorithms using the **C1\_ALTBLDIV1** algorithm type to design the required alternate bill ID format using the above mentioned parameters.

## Enabling the Alternate Sequential Bill Numbers Feature

---

### Prerequisites

To enable the alternate sequential bill numbers feature, you should have:

- An algorithm created using the **C1\_ALTBLLSYS**, **C1\_ALTBLSYS1**, **C1\_ALTBLDV**, or **C1\_ALTBLDIV1** algorithm type depending on which you want to use for alternate sequential bill number generation

### Procedure

To enable the alternate sequential bill numbers feature:

1. Click the **Admin** link in the **Application** toolbar.

A list appears.

2. From the **Admin** menu, select **I** and then click **Installation Options**.

The **Installation Options** screen appears.

3. Click the **Billing** tab.

The **Billing** tab appears.

4. Select the **Use Sequential Bill Numbers** check box to indicate that you want to generate alternate sequential bill numbers for completed bills.

The **Sequential Invoice** field is enabled.

5. Select the **System-wide** or **Division-specific** option from the **Sequential Invoice** list depending on whether you want alternate sequential bill numbers to be unique throughout the system or within the division.

6. Do either of the following:

If you want to generate...	Then
Alternate sequential bill numbers unique throughout the system	<ol style="list-style-type: none"> <li>1. Attach an algorithm created using the <b>C1_ALTBLLSYS</b> algorithm type to the <b>Sequence Generation Algorithm</b> field to indicate how the alternate bill numbers which are unique throughout the system should be sequenced.</li> </ol>

If you want to generate...	Then
	<p><b>Note:</b> The <b>Sequence Generation Algorithm</b> field is enabled only when you select the <b>System-wide</b> option from the <b>Sequential Invoice</b> list.</p> <ol style="list-style-type: none"> <li>Click the <b>Save</b> button in the <b>Page Title</b> area. The changes made to the installation options are saved.</li> </ol>
Alternate sequential bill numbers unique within the division	<ol style="list-style-type: none"> <li>Click the <b>Save</b> button in the <b>Page Title</b> area. The changes made to the installation options are saved.</li> <li>Search for the division, whose accounts' bills should have alternate sequential bill numbers unique within the division, in the <b>Division</b> screen. The <b>Division</b> screen appears.</li> <li>Click the <b>Algorithms</b> tab. The <b>Algorithms</b> tab appears.</li> <li>Select the <b>Sequential Bill Number Generation</b> option from the <b>Division Algorithm Entity</b> list.</li> <li>Enter the sequence number to indicate the order in which the algorithms with the same entity should be executed.</li> <li>Attach an algorithm created using the <b>C1_ALTBLDV</b> algorithm type to the respective field to indicate how alternate bill numbers which are unique within the division should be sequenced.</li> <li>Click the <b>Save</b> button in the <b>Page Title</b> area. The changes made to the division are saved.</li> </ol>
Alternate sequential bill numbers unique throughout the system and in the required format using a set of parameters	<ol style="list-style-type: none"> <li>Attach an algorithm created using the <b>C1_ALTBLSYS1</b> algorithm type to the <b>Sequence Generation Algorithm</b> field to indicate how the alternate bill numbers which are unique throughout the system should be generated.</li> </ol> <p><b>Note:</b> The <b>Sequence Generation Algorithm</b> field is enabled only when you select the <b>System-wide</b> option from the <b>Sequential Invoice</b> list. The alternate sequential bill number will be unique throughout the system only when you configure the algorithm parameters appropriately.</p> <ol style="list-style-type: none"> <li>Click the <b>Save</b> button in the <b>Page Title</b> area. The changes made to the installation options are saved.</li> </ol>

If you want to generate...	Then
<p>Alternate sequential bill numbers unique within the division and in the required format using a set of parameters</p>	<ol style="list-style-type: none"> <li>1. Click the <b>Save</b> button in the <b>Page Title</b> area. The changes made to the installation options are saved.</li> <li>2. Search for the division, whose accounts' bills should have alternate sequential bill numbers unique within the division, in the <b>Division</b> screen. The <b>Division</b> screen appears.</li> <li>3. Click the <b>Algorithms</b> tab. The <b>Algorithms</b> tab appears.</li> <li>4. Select the <b>Sequential Bill Number Generation</b> option from the <b>Division Algorithm Entity</b> list.</li> <li>5. Enter the sequence number to indicate the order in which the algorithms with the same entity should be executed.</li> <li>6. Attach an algorithm created using the <b>C1_ALTBLDIV1</b> algorithm type to the respective field to indicate how the alternate bill numbers which are unique within the division should be generated.</li> </ol> <div style="border: 1px solid black; padding: 5px; margin: 10px 0;"> <p><b>Note:</b> The alternate sequential bill number will be unique within the division only when you configure the algorithm parameters appropriately.</p> </div> <ol style="list-style-type: none"> <li>7. Click the <b>Save</b> button in the <b>Page Title</b> area. The changes made to the division are saved.</li> </ol>

### Related Topics

For more information on...	See...
Alternate Sequential Bill Numbers	<a href="#">Alternate Sequential Bill Numbers</a> on page 797
Sequential Bill Number Generation Algorithms	<a href="#">Sequential Bill Number Generation Algorithms</a> on page 798

---

# Chapter 10

---

## Currency Conversion

---

### Topics:

- [Prerequisites](#)
- [Bill Segment Generation](#)
- [Adjustment Creation](#)
- [Payment and Tender Creation](#)
- [Transaction Aggregation](#)
- [FT GL Creation](#)
- [Currency Conversion Algorithms](#)
- [Exchange Rate \(Used for Searching\)](#)
- [Exchange Rate \(Used for Viewing\)](#)

Oracle Revenue Management and Billing supports currency conversion using an exchange rate. The currency conversion feature is used only when the multi-currency accounts feature is enabled. In other words, you can use the currency conversion feature only when the **Allow Multi-Currency Accounts** option type of the **Multi-Currency Accounts (C1\_MLTCURACC)** feature configuration is set to **Y**.

The currency conversion can take place during the following business processes which are configured in the system:

- Bill Segment Generation
- Adjustment Creation
- Payment and Tender Creation
- FT GL Creation
- Transaction Aggregation

To enable the currency conversion feature, you need to attach the currency conversion algorithm at the division level. The system facilitates you to define different conversion currency algorithm for each business process. The currency conversion feature functions only when the appropriate exchange rate is available in the system. Otherwise, erroneous results might occur.

The system allows you to define date or date and time based global and division-specific exchange rates. The date based exchange rate mean that the exchange rate is applicable throughout the day. However, the date and time based exchange rate mean that the exchange rate is applicable from that date and time onwards.

**Note:** At present, time is not passed as input from any module (such as, payments, adjustments, billing, transaction feed management, and so on) during currency conversion. Therefore, even if you define date and time based exchange rates and use the date and time based currency conversion algorithms at the division level, the system will not search date and time based exchange rate when multiple exchange rates are available on the same day. The system will randomly pick an exchange rate on that day. The implementation team has to build the custom logic to pass or input time to the date and time based currency conversion algorithms in order to derive the appropriate exchange rate.

The system might use the direct division-specific or global exchange rate (i.e. FROM CCY to TO CCY) or direct reverse division-specific or global exchange rate (i.e. TO CCY to FROM CCY) during currency conversion. If either direct or direct reverse exchange rate is not available, the system might use division-specific or global exchange rate through base currency during

currency conversion. You can define the order in which exchange rate must be searched in the currency conversion algorithm.

While converting the amount from the source currency to the target currency (i.e. FROM CCY to TO CCY), the system uses the precision (i.e. decimal positions) of the target currency (i.e. TO CCY). For example, if you set the decimal positions for USD and INR to 1 and 2, respectively, the system uses 1 decimal position during currency conversion from INR to USD.

The system provides you with a facility to define whether you want to enable or disable the currency conversion feature for a rate component. If the currency conversion feature is enabled for a rate component, the currency conversion will take place while generating bill segments for the rate (i.e. rate component) based billable charges.



## Prerequisites

---

To setup the currency conversion feature, you need to do the following:

- Define the required divisions and currencies in the system
- Define the values for the **CONV\_TYPE\_FLG** and **EXCH\_RATE\_SRC\_FLG** lookup fields
- Define the Determine Business Object algorithm using the **F1-MOBO** algorithm type and attach it to the **C1\_EXCHRATE** maintenance object

**Note:** The **C1-ExchangeRate** and **C1\_EXCHRATE\_BO** business objects are shipped with the product. The **C1-ExchangeRate** business object is used while defining and editing date and time based exchange rates. However, the **C1\_EXCHRATE\_BO** business object is used while defining and editing date based exchange rates. Depending on whether you want to define date or date and time based exchange rates, you need to accordingly set the **Business Object** parameter in the Determine Business Object algorithm. The system will then accordingly display the fields while defining or editing an exchange rate.

- Define the required exchange rates for currency conversion
- Set the following option types of the **Multi-Currency Accounts (C1\_MLTCURACC)** feature configuration:
  - Allow Multi-Currency Accounts
  - Transfer Adjustment Type
- Set the **Allow Currency Conversion** field for each rate component to either **Yes** or **No** depending on whether you want to enable the currency conversion feature for the rate (i.e. rate component) based billable charges
- Create an algorithm of the **C1\_CURALGBS** or **C1\_EXCRTBS** algorithm type and attach it to the **Currency Conversion For Bill Segments** algorithm spot of the division when you want to enable currency conversion during:
  - Bill Segment Generation
  - FT GL Creation for Bill Segments

**Note:** The **C1\_CURALGBS** algorithm type uses date based exchange rate during currency conversion. However, the **C1\_EXCRTBS** algorithm type uses date and time based exchange rate during currency conversion.

- Create an algorithm of the **C1\_CURALGAD** or **C1\_EXCRTAD** algorithm type and attach it to the **Currency Conversion For Adjustments** algorithm spot of the division when you want to enable currency conversion during:
  - Adjustment Creation
  - FT GL Creation for Adjustments

**Note:** The **C1\_CURALGAD** algorithm type uses date based exchange rate during currency conversion. However, the **C1\_EXCRTAD** algorithm type uses date and time based exchange rate during currency conversion.

- Create an algorithm of the **C1\_CURALGPY** or **C1\_EXCRTPY** algorithm type and attach it to the **Currency Conversion For Payments** algorithm spot of the division when you want to enable currency conversion during:
  - Payment and Tender Creation
  - FT GL Creation for Payments

**Note:** The **C1\_CURALGPY** algorithm type uses date based exchange rate during currency conversion. However, the **C1\_EXCRTPY** algorithm type uses date and time based exchange rate during currency conversion.

- Create an algorithm of the **C1\_CURALGTFM** or **C1\_EXCRTTFM** algorithm type and attach it to the **TFM - Currency Conversion** algorithm spot of the division when you want to enable currency conversion during transaction aggregation

**Note:** The **C1\_CURALGTFM** algorithm type uses date based exchange rate during currency conversion. However, the **C1\_EXCRTTFM** algorithm type uses date and time based exchange rate during currency conversion.

- Create an algorithm of the **FTFREZGLEXTN** algorithm type and attach it on the **FT Freeze** system event of the customer class for which you want to create FT GL extension

### Related Topics

For more information on...	See...
<b>FTFREZGLEXTN</b> algorithm type	<a href="#">FTFREZGLEXTN</a> on page 829
<b>C1_CURALGBS</b> algorithm type	<a href="#">C1_CURALGBS</a> on page 814
<b>C1_CURALGAD</b> algorithm type	<a href="#">C1_CURALGAD</a> on page 815
<b>C1_CURALGPY</b> algorithm type	<a href="#">C1_CURALGPY</a> on page 817
<b>C1_CURALGTFM</b> algorithm type	<a href="#">C1_CURALGTFM</a> on page 819
<b>C1_EXCRTBS</b> algorithm type	<a href="#">C1_EXCRTBS</a> on page 821
<b>C1_EXCRTAD</b> algorithm type	<a href="#">C1_EXCRTAD</a> on page 822
<b>C1_EXCRTPY</b> algorithm type	<a href="#">C1_EXCRTPY</a> on page 824
<b>C1_EXCRTTFM</b> algorithm type	<a href="#">C1_EXCRTTFM</a> on page 826
How to set the <b>Multi-Currency Accounts (C1_MLTCURACC)</b> feature configuration	<a href="#">Setting the C1_MLTCURACC Feature Configuration</a>
How to define an exchange rate	<a href="#">Defining an Exchange Rate</a> on page 836

## Bill Segment Generation

The system allows you to generate bill segments using the following:

- **Pass through billable charges** — If the pass through billable charges have a bill line currency which is different from the account's invoice currency, the bill line amount is converted into the account's invoice currency during the bill segment generation.
- **Rate based billable charges** — If the rate based billable charges have a pricing currency which is different from the account's invoice currency, the amount is converted into the account's invoice currency during the bill segment generation.

In addition, during the post processing bill segment generation, if the pricing currency is different from the account's invoice currency, then the amount is converted into the account's invoice currency. The currency conversion is done only when you have an algorithm of the **C1\_CURALGBS** or **C1\_EXCRTBS** algorithm type attached on the **Currency Conversion For Bill Segments** algorithm spot of the respective division. In addition, the currency conversion is done for rate based billable charges only when the **Allow Currency Conversion** field in the respective rate component is set to **Yes**. Otherwise, the currency conversion will not happen. If the required exchange rate is not available during currency conversion, the status of the bill segment will change to **Error**.

### Related Topics

For more information on...	See...
<b>C1_CURALGBS</b> algorithm type	<a href="#">CI_CURALGBS</a> on page 814
<b>C1_EXCRTBS</b> algorithm type	<a href="#">CI_EXCRTBS</a> on page 821

## Adjustment Creation

There might be situations when the adjustment currency is different from the account's invoice currency. The system enables you to determine whether currency conversion must be done during adjustment creation or during bill completion. If you clear the **Print by Default** check box in the respective adjustment type, the currency conversion takes place during adjustment creation. However, if you select the **Print by Default** check box in the respective adjustment type, the currency conversion takes place during bill completion and not during adjustment creation. A transfer adjustment is created in the account's invoice currency and the reverse adjustment is created against the original adjustment in the adjustment currency when you complete the next bill of the account. The system creates the transfer and reverse adjustments using the adjustment type specified in the **Transfer Adjustment Type** option type of the **Multi-Currency Accounts (C1\_MLTCURACC)** feature configuration.

The currency conversion is done only when you have an algorithm of the **C1\_CURALGAD** or **C1\_EXCRTAD** algorithm type attached on the **Currency Conversion For Adjustments** algorithm spot of the respective division. Otherwise, the currency conversion will not happen. If the required exchange rate is not available during currency conversion, the transfer adjustment will not be created.

### Related Topics

For more information on...	See...
<b>C1_CURALGAD</b> algorithm type	<a href="#">CI_CURALGAD</a> on page 815
<b>C1_EXCRTAD</b> algorithm type	<a href="#">CI_EXCRTAD</a> on page 822

## Payment and Tender Creation

If the payment currency is different from the account's invoice currency, the amount is converted into the account's invoice currency during payment and tender creation. The currency conversion is done only when you have an algorithm of the **C1\_CURALGPY** or **C1\_EXCRTPY** algorithm type attached on the **Currency Conversion For Payments** algorithm spot of the respective division. Otherwise, the currency conversion will not happen. If the required exchange rate is not available during currency conversion, the payment and tenders will not be created.

### Note:

The currency conversion feature is available only when the payment currency (i.e. tender currency) is different from the payor account's invoice currency and not when the payor account's invoice currency is different from the payee account's invoice currency.

The currency conversion feature for payments is currently not supported from the **Payment Portal** screen and while uploading payment data from an external source.

### Related Topics

For more information on...	See...
<b>C1_CURALGPY</b> algorithm type	<a href="#">CI_CURALGPY</a> on page 817
<b>C1_EXCRTPY</b> algorithm type	<a href="#">CI_EXCRTPY</a> on page 824

## Transaction Aggregation

---

If the transaction or user defined (UDF) currency is different from the pricing currency, the amount is converted into the pricing currency when you are aggregating transactions based on the transaction or UDF amount. The currency conversion is done only when you have an algorithm of the **C1\_CURALGTFM** or **C1\_EXCRTTFM** algorithm type attached on the **TFM - Currency Conversion** algorithm spot of the respective division. Otherwise, the currency conversion will not happen. If the required exchange rate is not available during currency conversion, the status of the transaction will change to **Error**.

### Related Topics

For more information on...	See...
<b>C1_CURALGTFM</b> algorithm type	<a href="#">CI_CURALGTFM</a> on page 819
<b>C1_EXCRTTFM</b> algorithm type	<a href="#">CI_EXCRTTFM</a> on page 826

## FT GL Creation

---

During FT GL creation, the system creates an FT GL extension when the account's invoice currency is different from the division's base currency. The FT GL extension is created for the following financial transaction (FT) types:

- Adjustment
- Adjustment Cancellation
- Bill Segment
- Bill Cancellation
- Pay Segment
- Pay Cancellation

The FT GL extension is created for bill segments only when you have an algorithm of the **C1\_CURALGBS** or **C1\_EXCRTBS** algorithm type attached on the **Currency Conversion For Bill Segments** algorithm spot of the respective division. The FT GL extension is created for payments only when you have an algorithm of the **C1\_CURALGPY** or **C1\_EXCRTPY** algorithm type attached on the **Currency Conversion For Payments** algorithm spot of the respective division. The FT GL extension is created for adjustments only when you have an algorithm of the **C1\_CURALGAD** or **C1\_EXCRTAD** algorithm type attached on the **Currency Conversion For Adjustments** algorithm spot of the respective division. Otherwise, the currency conversion will not happen and the FT GL extension will not be created. In addition, if the required exchange rate is not available during currency conversion, the FT GL extension will not be created.

### Related Topics

For more information on...	See...
<b>FTFREZGLEXTN</b> algorithm type	<a href="#">FTFREZGLEXTN</a> on page 829
<b>C1_CURALGBS</b> algorithm type	<a href="#">CI_CURALGBS</a> on page 814
<b>C1_CURALGAD</b> algorithm type	<a href="#">CI_CURALGAD</a> on page 815
<b>C1_CURALGPY</b> algorithm type	<a href="#">CI_CURALGPY</a> on page 817
<b>C1_EXCRTBS</b> algorithm type	<a href="#">CI_EXCRTBS</a> on page 821
<b>C1_EXCRTPY</b> algorithm type	<a href="#">CI_EXCRTPY</a> on page 824

For more information on...	See...
C1_EXCRTAD algorithm type	<a href="#">CI_EXCRTAD</a> on page 822

## Currency Conversion Algorithms

The following table lists the currency conversion algorithm types shipped with the product:

If you want to use...	Then create algorithm using the following algorithm type....
Date based exchange rate during currency conversion while: <ul style="list-style-type: none"> <li>• Bill Segment Generation</li> <li>• FT GL Creation for Bill Segments</li> </ul>	<a href="#">CI_CURALGBS</a> on page 814
Date based exchange rate during currency conversion while: <ul style="list-style-type: none"> <li>• Adjustment Creation</li> <li>• FT GL Creation for Adjustments</li> </ul>	<a href="#">CI_CURALGAD</a> on page 815
Date based exchange rate during currency conversion while: <ul style="list-style-type: none"> <li>• Payment and Tender Creation</li> <li>• FT GL Creation for Payments</li> </ul>	<a href="#">CI_CURALGPY</a> on page 817
Date based exchange rate during currency conversion while aggregating transactions	<a href="#">CI_CURALGTFM</a> on page 819
Date and time based exchange rate during currency conversion while: <ul style="list-style-type: none"> <li>• Bill Segment Generation</li> <li>• FT GL Creation for Bill Segments</li> </ul>	<a href="#">CI_EXCRTBS</a> on page 821
Date and time based exchange rate during currency conversion while: <ul style="list-style-type: none"> <li>• Adjustment Creation</li> <li>• FT GL Creation for Adjustments</li> </ul>	<a href="#">CI_EXCRTAD</a> on page 822
Date and time based exchange rate during currency conversion while: <ul style="list-style-type: none"> <li>• Payment and Tender Creation</li> <li>• FT GL Creation for Payments</li> </ul>	<a href="#">CI_EXCRTPY</a> on page 824
Date and time based exchange rate during currency conversion while aggregating transactions	<a href="#">CI_EXCRTTFM</a> on page 826

## C1\_CURALGBS

The **C1\_CURALGBS** algorithm type is used to convert the amount in one currency to another currency using date based exchange rate. You can define date or date and time based global and division-specific exchange rates. The system might use the direct division-specific or global exchange rate (i.e. FROM CCY to TO CCY) or direct reverse division-specific or global exchange rate (i.e. TO CCY to FROM CCY) during currency conversion. If either direct or direct reverse exchange rate is not available, the system might use division-specific or global exchange rate through base currency during currency conversion. For example, if the FROM CCY is Canadian Dollars, TO CCY is Japanese Yen, and the division's base currency is U.S. Dollars, the system will first convert the amount from Canadian Dollars to U.S. Dollars and then convert the amount from U.S. Dollars to Japanese Yen.

The system allows you to indicate the order, in which the exchange rate must be searched, in the currency conversion algorithm. If you use the **Direct Rate First** search order, the system searches for an exchange rate in the specified order:

1. Division-specific direct exchange rate
2. Global direct exchange rate
3. Division-specific direct reverse exchange rate (if the **Division Reverse Rate** parameter is set to **Yes**)
4. Global direct reverse exchange rate (if the **Global Reverse Rate** parameter is set to **Yes**)
5. Division-specific exchange rate through base currency
6. Division-specific reverse exchange rate through base currency (if the **Division Reverse Rate** parameter is set to **Yes**)
7. Global exchange rate through base currency
8. Global reverse exchange rate through base currency (if the **Global Reverse Rate** parameter is set to **Yes**)

If you use the **Division First** search order, the system searches for an exchange rate in the specified order:

1. Division-specific direct exchange rate
2. Division-specific direct reverse exchange rate (if the **Division Reverse Rate** parameter is set to **Yes**)
3. Division-specific exchange rate through base currency
4. Division-specific reverse exchange rate through base currency (if the **Division Reverse Rate** parameter is set to **Yes**)
5. Global direct exchange rate
6. Global direct reverse exchange rate (if the **Global Reverse Rate** parameter is set to **Yes**)
7. Global exchange rate through base currency
8. Global reverse exchange rate through base currency (if the **Global Reverse Rate** parameter is set to **Yes**)

You need to attach an algorithm of the **C1\_CURALGBS** algorithm type on the **Currency Conversion For Bill Segments** algorithm spot of the division for which you want to enable the currency conversion feature. Once the algorithm is attached, the currency conversion will take place during:

- Bill Segment Generation
- FT GL Creation for Bill Segments

The **C1\_CURALGBS** algorithm type contains the following parameters:

Parameter	Description	Mandatory (Yes or No)
Override Base Currency	Used to specify the base currency. This will override division's base currency while searching for an exchange rate through base currency.	No
Conversion Type	Used when you want to use the exchanges rates with a particular conversion type during currency conversion.  <b>Note:</b> The parameter value must be already defined as a value in the <b>CONV_TYPE_FLG</b> lookup field.	No

Parameter	Description	Mandatory (Yes or No)
Search Order (Valid Values: Division First, Direct Rate First)	Used to indicate the order in which you want to search for an exchange rate during currency conversion. The valid values are: <ul style="list-style-type: none"> <li>• Direct Rate First</li> <li>• Division First</li> </ul> If you do not specify the value for this parameter, by default, the system uses the <b>Division First</b> search order.	No
Division Reverse Rate (Valid Values: Yes, No)	Used to indicate whether you want the system to search for division-specific reverse exchange rate (i.e. To CCY to From CCY). The valid values are: <ul style="list-style-type: none"> <li>• Yes</li> <li>• No</li> </ul> If you do not specify the value for this parameter, by default, the system does not use the division-specific reverse exchange rate.	No
Global Reverse Rate (Valid Values: Yes, No)	Used to indicate whether you want the system to search for global reverse exchange rate (i.e. To CCY to From CCY). The valid values are: <ul style="list-style-type: none"> <li>• Yes</li> <li>• No</li> </ul> If you do not specify the value for this parameter, by default, the system does not use the global reverse exchange rate.	No

### Related Topics

For more information on...	See...
Bill Segment Generation	<a href="#">Bill Segment Generation</a> on page 810
FT GL Creation	<a href="#">FT GL Creation</a> on page 812
How to setup the currency conversion feature	<a href="#">Prerequisites</a> on page 809

## C1\_CURALGAD

The **C1\_CURALGAD** algorithm type is used to convert the amount in one currency to another currency using date based exchange rate. You can define date or date and time based global and division-specific exchange rates. The system might use the direct division-specific or global exchange rate (i.e. FROM CCY to TO CCY) or direct reverse division-specific or global exchange rate (i.e. TO CCY to FROM CCY) during currency conversion. If either direct or direct reverse exchange rate is not available, the system might use division-specific or global exchange rate through base currency during currency conversion. For example, if the FROM CCY is Canadian Dollars, TO CCY is Japanese Yen, and the division's base currency is U.S. Dollars, the system will first convert the amount from Canadian Dollars to U.S. Dollars and then convert the amount from U.S. Dollars to Japanese Yen.

The system allows you to indicate the order, in which the exchange rate must be searched, in the currency conversion algorithm. If you use the **Direct Rate First** search order, the system searches for an exchange rate in the specified order:

1. Division-specific direct exchange rate
2. Global direct exchange rate

3. Division-specific direct reverse exchange rate (if the **Division Reverse Rate** parameter is set to **Yes**)
4. Global direct reverse exchange rate (if the **Global Reverse Rate** parameter is set to **Yes**)
5. Division-specific exchange rate through base currency
6. Division-specific reverse exchange rate through base currency (if the **Division Reverse Rate** parameter is set to **Yes**)
7. Global exchange rate through base currency
8. Global reverse exchange rate through base currency (if the **Global Reverse Rate** parameter is set to **Yes**)

If you use the **Division First** search order, the system searches for an exchange rate in the specified order:

1. Division-specific direct exchange rate
2. Division-specific direct reverse exchange rate (if the **Division Reverse Rate** parameter is set to **Yes**)
3. Division-specific exchange rate through base currency
4. Division-specific reverse exchange rate through base currency (if the **Division Reverse Rate** parameter is set to **Yes**)
5. Global direct exchange rate
6. Global direct reverse exchange rate (if the **Global Reverse Rate** parameter is set to **Yes**)
7. Global exchange rate through base currency
8. Global reverse exchange rate through base currency (if the **Global Reverse Rate** parameter is set to **Yes**)

You need to attach an algorithm of the **C1\_CURALGAD** algorithm type on the **Currency Conversion For Adjustments** algorithm spot of the division for which you want to enable the currency conversion feature. Once the algorithm is attached, the currency conversion will take place during:

- Adjustment Creation
- FT GL Creation for Adjustments

The **C1\_CURALGAD** algorithm type contains the following parameters:

Parameter	Description	Mandatory (Yes or No)
Override Base Currency	Used to specify the base currency. This will override division's base currency while searching for an exchange rate through base currency.	No
Conversion Type	Used when you want to use the exchanges rates with a particular conversion type during currency conversion.  <b>Note:</b> The parameter value must be already defined as a value in the <b>CONV_TYPE_FLG</b> lookup field.	No
Search Order (Valid Values: Division First, Direct Rate First)	Used to indicate the order in which you want to search for an exchange rate during currency conversion. The valid values are: <ul style="list-style-type: none"> <li>• Direct Rate First</li> <li>• Division First</li> </ul> <p>If you do not specify the value for this parameter, by default, the system uses the <b>Division First</b> search order.</p>	No



Parameter	Description	Mandatory (Yes or No)
Division Reverse Rate (Valid Values: Yes, No)	Used to indicate whether you want the system to search for division-specific reverse exchange rate (i.e. To CCY to From CCY). The valid values are: <ul style="list-style-type: none"> <li>• Yes</li> <li>• No</li> </ul> If you do not specify the value for this parameter, by default, the system does not use the division-specific reverse exchange rate.	No
Global Reverse Rate (Valid Values: Yes, No)	Used to indicate whether you want the system to search for global reverse exchange rate (i.e. To CCY to From CCY). The valid values are: <ul style="list-style-type: none"> <li>• Yes</li> <li>• No</li> </ul> If you do not specify the value for this parameter, by default, the system does not use the global reverse exchange rate.	No

### **Related Topics**

For more information on...	See...
Adjustment Creation	<a href="#">Adjustment Creation</a> on page 811
FT GL Creation	<a href="#">FT GL Creation</a> on page 812
How to setup the currency conversion feature	<a href="#">Prerequisites</a> on page 809

## **C1\_CURALGPY**

The **C1\_CURALGPY** algorithm type is used to convert the amount in one currency to another currency using date based exchange rate. You can define date or date and time based global and division-specific exchange rates. The system might use the direct division-specific or global exchange rate (i.e. FROM CCY to TO CCY) or direct reverse division-specific or global exchange rate (i.e. TO CCY to FROM CCY) during currency conversion. If either direct or direct reverse exchange rate is not available, the system might use division-specific or global exchange rate through base currency during currency conversion. For example, if the FROM CCY is Canadian Dollars, TO CCY is Japanese Yen, and the division's base currency is U.S. Dollars, the system will first convert the amount from Canadian Dollars to U.S. Dollars and then convert the amount from U.S. Dollars to Japanese Yen.

The system allows you to indicate the order, in which the exchange rate must be searched, in the currency conversion algorithm. If you use the **Direct Rate First** search order, the system searches for an exchange rate in the specified order:

1. Division-specific direct exchange rate
2. Global direct exchange rate
3. Division-specific direct reverse exchange rate (if the **Division Reverse Rate** parameter is set to **Yes**)
4. Global direct reverse exchange rate (if the **Global Reverse Rate** parameter is set to **Yes**)
5. Division-specific exchange rate through base currency
6. Division-specific reverse exchange rate through base currency (if the **Division Reverse Rate** parameter is set to **Yes**)
7. Global exchange rate through base currency

8. Global reverse exchange rate through base currency (if the **Global Reverse Rate** parameter is set to **Yes**)

If you use the **Division First** search order, the system searches for an exchange rate in the specified order:

1. Division-specific direct exchange rate
2. Division-specific direct reverse exchange rate (if the **Division Reverse Rate** parameter is set to **Yes**)
3. Division-specific exchange rate through base currency
4. Division-specific reverse exchange rate through base currency (if the **Division Reverse Rate** parameter is set to **Yes**)
5. Global direct exchange rate
6. Global direct reverse exchange rate (if the **Global Reverse Rate** parameter is set to **Yes**)
7. Global exchange rate through base currency
8. Global reverse exchange rate through base currency (if the **Global Reverse Rate** parameter is set to **Yes**)

You need to attach an algorithm of the **C1\_CURALGPY** algorithm type on the **Currency Conversion For Payments** algorithm spot of the division for which you want to enable the currency conversion feature. Once the algorithm is attached, the currency conversion will take place during:

- Payment and Tender Creation
- FT GL Creation for Payments

The **C1\_CURALGPY** algorithm type contains the following parameters:

Parameter	Description	Mandatory (Yes or No)
Override Base Currency	Used to specify the base currency. This will override division's base currency while searching for an exchange rate through base currency.	No
Conversion Type	Used when you want to use the exchanges rates with a particular conversion type during currency conversion.  <b>Note:</b> The parameter value must be already defined as a value in the <b>CONV_TYPE_FLG</b> lookup field.	No
Search Order (Valid Values: Division First, Direct Rate First)	Used to indicate the order in which you want to search for an exchange rate during currency conversion. The valid values are: <ul style="list-style-type: none"> <li>• Direct Rate First</li> <li>• Division First</li> </ul> If you do not specify the value for this parameter, by default, the system uses the <b>Division First</b> search order.	No
Division Reverse Rate (Valid Values: Yes, No)	Used to indicate whether you want the system to search for division-specific reverse exchange rate (i.e. To CCY to From CCY). The valid values are: <ul style="list-style-type: none"> <li>• Yes</li> <li>• No</li> </ul> If you do not specify the value for this parameter, by default, the system does not use the division-specific reverse exchange rate.	No

Parameter	Description	Mandatory (Yes or No)
Global Reverse Rate (Valid Values: Yes, No)	Used to indicate whether you want the system to search for global reverse exchange rate (i.e. To CCY to From CCY). The valid values are: <ul style="list-style-type: none"> <li>• Yes</li> <li>• No</li> </ul> If you do not specify the value for this parameter, by default, the system does not use the global reverse exchange rate.	No

### Related Topics

For more information on...	See...
Payment and Tender Creation	<a href="#">Payment and Tender Creation</a> on page 811
FT GL Creation	<a href="#">FT GL Creation</a> on page 812
How to setup the currency conversion feature	<a href="#">Prerequisites</a> on page 809

## C1\_CURALGTFM

The **C1\_CURALGTFM** algorithm type is used to convert the amount in one currency to another currency using date based exchange rate. You can define date or date and time based global and division-specific exchange rates. The system might use the direct division-specific or global exchange rate (i.e. FROM CCY to TO CCY) or direct reverse division-specific or global exchange rate (i.e. TO CCY to FROM CCY) during currency conversion. If either direct or direct reverse exchange rate is not available, the system might use division-specific or global exchange rate through base currency during currency conversion. For example, if the FROM CCY is Canadian Dollars, TO CCY is Japanese Yen, and the division's base currency is U.S. Dollars, the system will first convert the amount from Canadian Dollars to U.S. Dollars and then convert the amount from U.S. Dollars to Japanese Yen.

The system allows you to indicate the order, in which the exchange rate must be searched, in the currency conversion algorithm. If you use the **Direct Rate First** search order, the system searches for an exchange rate in the specified order:

1. Division-specific direct exchange rate
2. Global direct exchange rate
3. Division-specific direct reverse exchange rate (if the **Division Reverse Rate** parameter is set to **Yes**)
4. Global direct reverse exchange rate (if the **Global Reverse Rate** parameter is set to **Yes**)
5. Division-specific exchange rate through base currency
6. Division-specific reverse exchange rate through base currency (if the **Division Reverse Rate** parameter is set to **Yes**)
7. Global exchange rate through base currency
8. Global reverse exchange rate through base currency (if the **Global Reverse Rate** parameter is set to **Yes**)

If you use the **Division First** search order, the system searches for an exchange rate in the specified order:

1. Division-specific direct exchange rate
2. Division-specific direct reverse exchange rate (if the **Division Reverse Rate** parameter is set to **Yes**)
3. Division-specific exchange rate through base currency
4. Division-specific reverse exchange rate through base currency (if the **Division Reverse Rate** parameter is set to **Yes**)
5. Global direct exchange rate
6. Global direct reverse exchange rate (if the **Global Reverse Rate** parameter is set to **Yes**)

7. Global exchange rate through base currency

8. Global reverse exchange rate through base currency (if the **Global Reverse Rate** parameter is set to **Yes**)

You need to attach an algorithm of the **C1\_CURALGTFM** algorithm type on the **TFM - Currency Conversion** algorithm spot of the division for which you want to enable the currency conversion feature. Once the algorithm is attached, the currency conversion will take place during the transaction aggregation process when the transaction or UDF currency is different from the pricing currency.

The **C1\_CURALGTFM** algorithm type contains the following parameters:

Parameter	Description	Mandatory (Yes or No)
Override Base Currency	Used to specify the base currency. This will override division's base currency while searching for an exchange rate through base currency.	No
Conversion Type	Used when you want to use the exchanges rates with a particular conversion type during currency conversion.  <b>Note:</b> The parameter value must be already defined as a value in the <b>CONV_TYPE_FLG</b> lookup field.	No
Search Order (Valid Values: Division First, Direct Rate First)	Used to indicate the order in which you want to search for an exchange rate during currency conversion. The valid values are: <ul style="list-style-type: none"> <li>• Direct Rate First</li> <li>• Division First</li> </ul> If you do not specify the value for this parameter, by default, the system uses the <b>Division First</b> search order.	No
Division Reverse Rate (Valid Values: Yes, No)	Used to indicate whether you want the system to search for division-specific reverse exchange rate (i.e. To CCY to From CCY). The valid values are: <ul style="list-style-type: none"> <li>• Yes</li> <li>• No</li> </ul> If you do not specify the value for this parameter, by default, the system does not use the division-specific reverse exchange rate.	No
Global Reverse Rate (Valid Values: Yes, No)	Used to indicate whether you want the system to search for global reverse exchange rate (i.e. To CCY to From CCY). The valid values are: <ul style="list-style-type: none"> <li>• Yes</li> <li>• No</li> </ul> If you do not specify the value for this parameter, by default, the system does not use the global reverse exchange rate.	No

### **Related Topics**

For more information on...	See...
Transaction Aggregation	<a href="#">Transaction Aggregation</a> on page 812
FT GL Creation	<a href="#">FT GL Creation</a> on page 812

For more information on...	See...
How to setup the currency conversion feature	<a href="#">Prerequisites</a> on page 809

## C1\_EXCRTBS

The **C1\_EXCRTBS** algorithm type is used to convert the amount in one currency to another currency using date and time based exchange rate. You can define date or date and time based global and division-specific exchange rates. The system might use the direct division-specific or global exchange rate (i.e. FROM CCY to TO CCY) or direct reverse division-specific or global exchange rate (i.e. TO CCY to FROM CCY) during currency conversion. If either direct or direct reverse exchange rate is not available, the system might use division-specific or global exchange rate through base currency during currency conversion. For example, if the FROM CCY is Canadian Dollars, TO CCY is Japanese Yen, and the division's base currency is U.S. Dollars, the system will first convert the amount from Canadian Dollars to U.S. Dollars and then convert the amount from U.S. Dollars to Japanese Yen.

The system allows you to indicate the order, in which the exchange rate must be searched, in the currency conversion algorithm. If you use the **Direct Rate First** search order, the system searches for an exchange rate in the specified order:

1. Division-specific direct exchange rate
2. Global direct exchange rate
3. Division-specific direct reverse exchange rate (if the **Division Reverse Rate** parameter is set to **Yes**)
4. Global direct reverse exchange rate (if the **Global Reverse Rate** parameter is set to **Yes**)
5. Division-specific exchange rate through base currency
6. Division-specific reverse exchange rate through base currency (if the **Division Reverse Rate** parameter is set to **Yes**)
7. Global exchange rate through base currency
8. Global reverse exchange rate through base currency (if the **Global Reverse Rate** parameter is set to **Yes**)

If you use the **Division First** search order, the system searches for an exchange rate in the specified order:

1. Division-specific direct exchange rate
2. Division-specific direct reverse exchange rate (if the **Division Reverse Rate** parameter is set to **Yes**)
3. Division-specific exchange rate through base currency
4. Division-specific reverse exchange rate through base currency (if the **Division Reverse Rate** parameter is set to **Yes**)
5. Global direct exchange rate
6. Global direct reverse exchange rate (if the **Global Reverse Rate** parameter is set to **Yes**)
7. Global exchange rate through base currency
8. Global reverse exchange rate through base currency (if the **Global Reverse Rate** parameter is set to **Yes**)

You need to attach an algorithm of the **C1\_EXCRTBS** algorithm type on the **Currency Conversion For Bill Segments** algorithm spot of the division for which you want to enable the currency conversion feature. Once the algorithm is attached, the currency conversion will take place during:

- Bill Segment Generation
- FT GL Creation for Bill Segments

The **C1\_EXCRTBS** algorithm type contains the following parameters:

Parameter	Description	Mandatory (Yes or No)
Override Base Currency	Used to specify the base currency. This will override division's base currency while searching for an exchange rate through base currency.	No
Conversion Type	Used when you want to use the exchanges rates with a particular conversion type during currency conversion.  <b>Note:</b> The parameter value must be already defined as a value in the <b>CONV_TYPE_FLG</b> lookup field.	No

Parameter	Description	Mandatory (Yes or No)
Search Order (Valid Values: Division First, Direct Rate First)	Used to indicate the order in which you want to search for an exchange rate during currency conversion. The valid values are: <ul style="list-style-type: none"> <li>• Direct Rate First</li> <li>• Division First</li> </ul> If you do not specify the value for this parameter, by default, the system uses the <b>Division First</b> search order.	No
Division Reverse Rate (Valid Values: Yes, No)	Used to indicate whether you want the system to search for division-specific reverse exchange rate (i.e. To CCY to From CCY). The valid values are: <ul style="list-style-type: none"> <li>• Yes</li> <li>• No</li> </ul> If you do not specify the value for this parameter, by default, the system does not use the division-specific reverse exchange rate.	No
Global Reverse Rate (Valid Values: Yes, No)	Used to indicate whether you want the system to search for global reverse exchange rate (i.e. To CCY to From CCY). The valid values are: <ul style="list-style-type: none"> <li>• Yes</li> <li>• No</li> </ul> If you do not specify the value for this parameter, by default, the system does not use the global reverse exchange rate.	No
Exchange Rate Override Algorithm	Used to attach a custom algorithm when you want to use an exchange rate search mechanism other than the one defined in this algorithm.	No
Exchange Rate Source	Used when you want to use the exchanges rates received from a particular source during currency conversion. <div style="border: 1px solid black; padding: 2px; margin-top: 5px;"> <b>Note:</b> The parameter value must be already defined as a value in the <b>EXCH_RATE_SRC_FLG</b> lookup field. </div>	No

### Related Topics

For more information on...	See...
Bill Segment Generation	<a href="#">Bill Segment Generation</a> on page 810
FT GL Creation	<a href="#">FT GL Creation</a> on page 812
How to setup the currency conversion feature	<a href="#">Prerequisites</a> on page 809

## C1\_EXCRTAD

The **C1\_EXCRTAD** algorithm type is used to convert the amount in one currency to another currency using date and time based exchange rate. You can define date or date and time based global and division-specific exchange rates. The system might use the direct division-specific or global exchange rate (i.e. FROM CCY to TO CCY) or direct reverse division-specific or global exchange rate (i.e. TO CCY to FROM CCY) during currency conversion. If either direct or

direct reverse exchange rate is not available, the system might use division-specific or global exchange rate through base currency during currency conversion. For example, if the FROM CCY is Canadian Dollars, TO CCY is Japanese Yen, and the division's base currency is U.S. Dollars, the system will first convert the amount from Canadian Dollars to U.S. Dollars and then convert the amount from U.S. Dollars to Japanese Yen.

The system allows you to indicate the order, in which the exchange rate must be searched, in the currency conversion algorithm. If you use the **Direct Rate First** search order, the system searches for an exchange rate in the specified order:

1. Division-specific direct exchange rate
2. Global direct exchange rate
3. Division-specific direct reverse exchange rate (if the **Division Reverse Rate** parameter is set to **Yes**)
4. Global direct reverse exchange rate (if the **Global Reverse Rate** parameter is set to **Yes**)
5. Division-specific exchange rate through base currency
6. Division-specific reverse exchange rate through base currency (if the **Division Reverse Rate** parameter is set to **Yes**)
7. Global exchange rate through base currency
8. Global reverse exchange rate through base currency (if the **Global Reverse Rate** parameter is set to **Yes**)

If you use the **Division First** search order, the system searches for an exchange rate in the specified order:

1. Division-specific direct exchange rate
2. Division-specific direct reverse exchange rate (if the **Division Reverse Rate** parameter is set to **Yes**)
3. Division-specific exchange rate through base currency
4. Division-specific reverse exchange rate through base currency (if the **Division Reverse Rate** parameter is set to **Yes**)
5. Global direct exchange rate
6. Global direct reverse exchange rate (if the **Global Reverse Rate** parameter is set to **Yes**)
7. Global exchange rate through base currency
8. Global reverse exchange rate through base currency (if the **Global Reverse Rate** parameter is set to **Yes**)

You need to attach an algorithm of the **C1\_EXCRTAD** algorithm type on the **Currency Conversion For Adjustments** algorithm spot of the division for which you want to enable the currency conversion feature. Once the algorithm is attached, the currency conversion will take place during:

- Adjustment Creation
- FT GL Creation for Adjustments

The **C1\_EXCRTAD** algorithm type contains the following parameters:

Parameter	Description	Mandatory (Yes or No)
Override Base Currency	Used to specify the base currency. This will override division's base currency while searching for an exchange rate through base currency.	No
Conversion Type	Used when you want to use the exchanges rates with a particular conversion type during currency conversion.  <b>Note:</b> The parameter value must be already defined as a value in the <b>CONV_TYPE_FLG</b> lookup field.	No
Search Order (Valid Values: Division First, Direct Rate First)	Used to indicate the order in which you want to search for an exchange rate during currency conversion. The valid values are: <ul style="list-style-type: none"> <li>• Direct Rate First</li> <li>• Division First</li> </ul> If you do not specify the value for this parameter, by default, the system uses the <b>Division First</b> search order.	No

Parameter	Description	Mandatory (Yes or No)
Division Reverse Rate (Valid Values: Yes, No)	Used to indicate whether you want the system to search for division-specific reverse exchange rate (i.e. To CCY to From CCY). The valid values are: <ul style="list-style-type: none"> <li>• Yes</li> <li>• No</li> </ul> If you do not specify the value for this parameter, by default, the system does not use the division-specific reverse exchange rate.	No
Global Reverse Rate (Valid Values: Yes, No)	Used to indicate whether you want the system to search for global reverse exchange rate (i.e. To CCY to From CCY). The valid values are: <ul style="list-style-type: none"> <li>• Yes</li> <li>• No</li> </ul> If you do not specify the value for this parameter, by default, the system does not use the global reverse exchange rate.	No
Exchange Rate Override Algorithm	Used to attach a custom algorithm when you want to use an exchange rate search mechanism other than the one defined in this algorithm.	No
Exchange Rate Source	Used when you want to use the exchanges rates received from a particular source during currency conversion. <div style="border: 1px solid black; padding: 5px; margin-top: 10px;"> <b>Note:</b> The parameter value must be already defined as a value in the <b>EXCH_RATE_SRC_FLG</b> lookup field. </div>	No

### Related Topics

For more information on...	See...
Adjustment Creation	<a href="#">Adjustment Creation</a> on page 811
FT GL Creation	<a href="#">FT GL Creation</a> on page 812
How to setup the currency conversion feature	<a href="#">Prerequisites</a> on page 809

## C1\_EXCRTPY

The **C1\_EXCRTPY** algorithm type is used to convert the amount in one currency to another currency using date and time based exchange rate. You can define date or date and time based global and division-specific exchange rates. The system might use the direct division-specific or global exchange rate (i.e. FROM CCY to TO CCY) or direct reverse division-specific or global exchange rate (i.e. TO CCY to FROM CCY) during currency conversion. If either direct or direct reverse exchange rate is not available, the system might use division-specific or global exchange rate through base currency during currency conversion. For example, if the FROM CCY is Canadian Dollars, TO CCY is Japanese Yen, and the division's base currency is U.S. Dollars, the system will first convert the amount from Canadian Dollars to U.S. Dollars and then convert the amount from U.S. Dollars to Japanese Yen.

The system allows you to indicate the order, in which the exchange rate must be searched, in the currency conversion algorithm. If you use the **Direct Rate First** search order, the system searches for an exchange rate in the specified order:

1. Division-specific direct exchange rate
2. Global direct exchange rate



3. Division-specific direct reverse exchange rate (if the **Division Reverse Rate** parameter is set to **Yes**)
4. Global direct reverse exchange rate (if the **Global Reverse Rate** parameter is set to **Yes**)
5. Division-specific exchange rate through base currency
6. Division-specific reverse exchange rate through base currency (if the **Division Reverse Rate** parameter is set to **Yes**)
7. Global exchange rate through base currency
8. Global reverse exchange rate through base currency (if the **Global Reverse Rate** parameter is set to **Yes**)

If you use the **Division First** search order, the system searches for an exchange rate in the specified order:

1. Division-specific direct exchange rate
2. Division-specific direct reverse exchange rate (if the **Division Reverse Rate** parameter is set to **Yes**)
3. Division-specific exchange rate through base currency
4. Division-specific reverse exchange rate through base currency (if the **Division Reverse Rate** parameter is set to **Yes**)
5. Global direct exchange rate
6. Global direct reverse exchange rate (if the **Global Reverse Rate** parameter is set to **Yes**)
7. Global exchange rate through base currency
8. Global reverse exchange rate through base currency (if the **Global Reverse Rate** parameter is set to **Yes**)

You need to attach an algorithm of the **C1\_EXCRTPY** algorithm type on the **Currency Conversion For Payments** algorithm spot of the division for which you want to enable the currency conversion feature. Once the algorithm is attached, the currency conversion will take place during:

- Payment and Tender Creation
- FT GL Creation for Payments

The **C1\_EXCRTPY** algorithm type contains the following parameters:

Parameter	Description	Mandatory (Yes or No)
Override Base Currency	Used to specify the base currency. This will override division's base currency while searching for an exchange rate through base currency.	No
Conversion Type	Used when you want to use the exchanges rates with a particular conversion type during currency conversion.  <b>Note:</b> The parameter value must be already defined as a value in the <b>CONV_TYPE_FLG</b> lookup field.	No
Search Order (Valid Values: Division First, Direct Rate First)	Used to indicate the order in which you want to search for an exchange rate during currency conversion. The valid values are: <ul style="list-style-type: none"> <li>• Direct Rate First</li> <li>• Division First</li> </ul> If you do not specify the value for this parameter, by default, the system uses the <b>Division First</b> search order.	No

Parameter	Description	Mandatory (Yes or No)
Division Reverse Rate (Valid Values: Yes, No)	Used to indicate whether you want the system to search for division-specific reverse exchange rate (i.e. To CCY to From CCY). The valid values are: <ul style="list-style-type: none"> <li>• Yes</li> <li>• No</li> </ul> If you do not specify the value for this parameter, by default, the system does not use the division-specific reverse exchange rate.	No
Global Reverse Rate (Valid Values: Yes, No)	Used to indicate whether you want the system to search for global reverse exchange rate (i.e. To CCY to From CCY). The valid values are: <ul style="list-style-type: none"> <li>• Yes</li> <li>• No</li> </ul> If you do not specify the value for this parameter, by default, the system does not use the global reverse exchange rate.	No
Exchange Rate Override Algorithm	Used to attach a custom algorithm when you want to use an exchange rate search mechanism other than the one defined in this algorithm.	No
Exchange Rate Source	Used when you want to use the exchanges rates received from a particular source during currency conversion. <div style="border: 1px solid black; padding: 5px; margin-top: 10px;"> <b>Note:</b> The parameter value must be already defined as a value in the <b>EXCH_RATE_SRC_FLG</b> lookup field. </div>	No

### Related Topics

For more information on...	See...
Payment and Tender Creation	<a href="#">Payment and Tender Creation</a> on page 811
FT GL Creation	<a href="#">FT GL Creation</a> on page 812
How to setup the currency conversion feature	<a href="#">Prerequisites</a> on page 809

## C1\_EXCRTTFM

The **C1\_EXCRTTFM** algorithm type is used to convert the amount in one currency to another currency using date and time based exchange rate. You can define date or date and time based global and division-specific exchange rates. The system might use the direct division-specific or global exchange rate (i.e. FROM CCY to TO CCY) or direct reverse division-specific or global exchange rate (i.e. TO CCY to FROM CCY) during currency conversion. If either direct or direct reverse exchange rate is not available, the system might use division-specific or global exchange rate through base currency during currency conversion. For example, if the FROM CCY is Canadian Dollars, TO CCY is Japanese Yen, and the division's base currency is U.S. Dollars, the system will first convert the amount from Canadian Dollars to U.S. Dollars and then convert the amount from U.S. Dollars to Japanese Yen.

The system allows you to indicate the order, in which the exchange rate must be searched, in the currency conversion algorithm. If you use the **Direct Rate First** search order, the system searches for an exchange rate in the specified order:

1. Division-specific direct exchange rate

2. Global direct exchange rate
3. Division-specific direct reverse exchange rate (if the **Division Reverse Rate** parameter is set to **Yes**)
4. Global direct reverse exchange rate (if the **Global Reverse Rate** parameter is set to **Yes**)
5. Division-specific exchange rate through base currency
6. Division-specific reverse exchange rate through base currency (if the **Division Reverse Rate** parameter is set to **Yes**)
7. Global exchange rate through base currency
8. Global reverse exchange rate through base currency (if the **Global Reverse Rate** parameter is set to **Yes**)

If you use the **Division First** search order, the system searches for an exchange rate in the specified order:

1. Division-specific direct exchange rate
2. Division-specific direct reverse exchange rate (if the **Division Reverse Rate** parameter is set to **Yes**)
3. Division-specific exchange rate through base currency
4. Division-specific reverse exchange rate through base currency (if the **Division Reverse Rate** parameter is set to **Yes**)
5. Global direct exchange rate
6. Global direct reverse exchange rate (if the **Global Reverse Rate** parameter is set to **Yes**)
7. Global exchange rate through base currency
8. Global reverse exchange rate through base currency (if the **Global Reverse Rate** parameter is set to **Yes**)

You need to attach an algorithm of the **C1\_EXCRTTFM** algorithm type on the **TFM - Currency Conversion** algorithm spot of the division for which you want to enable the currency conversion feature. Once the algorithm is attached, the currency conversion will take place during the transaction aggregation process when the transaction or UDF currency is different from the pricing currency.

The **C1\_EXCRTTFM** algorithm type contains the following parameters:

Parameter	Description	Mandatory (Yes or No)
Override Base Currency	Used to specify the base currency. This will override division's base currency while searching for an exchange rate through base currency.	No
Conversion Type	Used when you want to use the exchanges rates with a particular conversion type during currency conversion.  <b>Note:</b> The parameter value must be already defined as a value in the <b>CONV_TYPE_FLG</b> lookup field.	No
Search Order (Valid Values: Division First, Direct Rate First)	Used to indicate the order in which you want to search for an exchange rate during currency conversion. The valid values are: <ul style="list-style-type: none"> <li>• Direct Rate First</li> <li>• Division First</li> </ul> If you do not specify the value for this parameter, by default, the system uses the <b>Division First</b> search order.	No

Parameter	Description	Mandatory (Yes or No)
Division Reverse Rate (Valid Values: Yes, No)	Used to indicate whether you want the system to search for division-specific reverse exchange rate (i.e. To CCY to From CCY). The valid values are: <ul style="list-style-type: none"> <li>• Yes</li> <li>• No</li> </ul> <p>If you do not specify the value for this parameter, by default, the system does not use the division-specific reverse exchange rate.</p>	No
Global Reverse Rate (Valid Values: Yes, No)	Used to indicate whether you want the system to search for global reverse exchange rate (i.e. To CCY to From CCY). The valid values are: <ul style="list-style-type: none"> <li>• Yes</li> <li>• No</li> </ul> <p>If you do not specify the value for this parameter, by default, the system does not use the global reverse exchange rate.</p>	No
Exchange Rate Override Algorithm	Used to attach a custom algorithm when you want to use an exchange rate search mechanism other than the one defined in this algorithm. <p><b>Note:</b> A sample algorithm type named <b>CI_EXCRTOVRD</b> is shipped with the product. It is used to fetch the exchange rate which is available corresponding to the transaction in the <b>CI_TXN_DETAIL</b> table. The exchange rate is then used by the algorithm which is created using the <b>CI_EXCRTTFM</b> algorithm type to convert the transaction amount from the transaction currency to the pricing currency. You must specify the column from where the exchange rate must be picked during currency conversion in the <b>Transaction Detail Field for Exchange Rate</b> parameter.</p>	No
Exchange Rate Source	Used when you want to use the exchanges rates received from a particular source during currency conversion. <p><b>Note:</b> The parameter value must be already defined as a value in the <b>EXCH_RATE_SRC_FLG</b> lookup field.</p>	No

### **Related Topics**

For more information on...	See...
Transaction Aggregation	<a href="#">Transaction Aggregation</a> on page 812
FT GL Creation	<a href="#">FT GL Creation</a> on page 812

For more information on...	See...
How to setup the currency conversion feature	<a href="#">Prerequisites</a> on page 809
C1_EXCRTOVRD algorithm type	<a href="#">C1_EXCRTOVRD</a> on page 831

## FTFREZGLEXTN

The **FTFREZGLEXTN** algorithm type is used to create FT GL extension for the following financial transaction (FT) types when the account's invoice currency is different from the division's base currency:

- Adjustment
- Adjustment Cancellation
- Bill Segment
- Bill Cancellation
- Pay Segment
- Pay Cancellation

You need to attach an algorithm of the **FTFREZGLEXTN** algorithm type on the **FT Freeze** system event of the customer class. The FT GL extension is created for bill segments only when you have an algorithm of the **C1\_CURALGBS** algorithm type attached on the **Currency Conversion For Bill Segments** algorithm spot of the respective division. The FT GL extension is created for payments only when you have an algorithm of the **C1\_CURALGPY** algorithm type attached on the **Currency Conversion For Payments** algorithm spot of the respective division. The FT GL extension is created for adjustments only when you have an algorithm of the **C1\_CURALGAD** algorithm type attached on the **Currency Conversion For Adjustments** algorithm spot of the respective division.

The **FTFREZGLEXTN** algorithm type contains the following parameters:

Parameter	Description	Mandatory (Yes or No)
Exchange Rate Date Type for Adjustments with Freeze At Will	Used to indicate the date on which the exchange rate should be picked up when FT GL extension is created for adjustments with the <b>Freeze At Will</b> option. The valid values are: <ul style="list-style-type: none"> <li>• <b>A (Accounting Date)</b> – Used to search for an exchange rate which is effective on the accounting date.</li> <li>• <b>R (Arrears Date)</b> - Used to search for an exchange rate which is effective on the arrears date.</li> <li>• <b>F (FT Freeze Date)</b> - Used to search for an exchange rate which is effective on the FT freeze date.</li> <li>• <b>C (FT Create Date)</b> - Used to search for an exchange rate which is effective on the FT creation date.</li> </ul>	Yes

Parameter	Description	Mandatory (Yes or No)
Exchange Rate Date Type for Adjustments with Freeze At Bill Completion	<p>Used to indicate the date on which the exchange rate should be picked up when FT GL extension is created for adjustments with the <b>Freeze At Bill Completion</b> option. The valid values are:</p> <ul style="list-style-type: none"> <li>• <b>A (Accounting Date)</b> – Used to search for an exchange rate which is effective on the accounting date.</li> <li>• <b>R (Arrears Date)</b> - Used to search for an exchange rate which is effective on the arrears date.</li> <li>• <b>F (FT Freeze Date)</b> - Used to search for an exchange rate which is effective on the FT freeze date.</li> <li>• <b>C (FT Create Date)</b> - Used to search for an exchange rate which is effective on the FT creation date.</li> </ul>	Yes
Exchange Rate Date Type for Payments (Valid Values: A, R, F, C)	<p>Used to indicate the date on which the exchange rate should be picked up when FT GL extension is created for payments. The valid values are:</p> <ul style="list-style-type: none"> <li>• <b>A (Accounting Date)</b> – Used to search for an exchange rate which is effective on the accounting date.</li> <li>• <b>R (Arrears Date)</b> - Used to search for an exchange rate which is effective on the arrears date.</li> <li>• <b>F (FT Freeze Date)</b> - Used to search for an exchange rate which is effective on the FT freeze date.</li> <li>• <b>C (FT Create Date)</b> - Used to search for an exchange rate which is effective on the FT creation date.</li> </ul>	Yes

Parameter	Description	Mandatory (Yes or No)
Exchange Rate Date Type for Bill Segments (Valid Values: A, R, F, C, E)	<p>Used to indicate the date on which the exchange rate should be picked up when FT GL extension is created for bill segments. The valid values are:</p> <ul style="list-style-type: none"> <li>• <b>A (Accounting Date)</b> – Used to search for an exchange rate which is effective on the accounting date.</li> <li>• <b>R (Arrears Date)</b> - Used to search for an exchange rate which is effective on the arrears date.</li> <li>• <b>F (FT Freeze Date)</b> - Used to search for an exchange rate which is effective on the FT freeze date.</li> <li>• <b>C (FT Create Date)</b> - Used to search for an exchange rate which is effective on the FT creation date.</li> <li>• <b>E (Bill Segment End Date)</b> - Used to search for an exchange rate which is effective on the bill segment end date.</li> </ul> <p><b>Note:</b> If you set the <b>Exchange Rate Date Type for Bill Segments</b> parameter to <b>R</b>, ensure that you set the <b>Bill Segment Freeze Option</b> to <b>Freeze At Bill Completion</b> in the <b>Billing</b> tab of the <b>Installation Options</b> screen. Otherwise, erroneous results might occur.</p>	Yes

### Related Topics

For more information on...	See...
FT GL Creation	<a href="#">FT GL Creation</a> on page 812
How to setup the currency conversion feature	<a href="#">Prerequisites</a> on page 809

## C1\_EXCRTOVRD

The **C1\_EXCRTOVRD** algorithm type is used to fetch the exchange rate which is available corresponding to the transaction in the **CI\_TXN\_DETAIL** table. The exchange rate is then used by the algorithm which is created using the **C1\_EXCRTTFM** algorithm type to convert the transaction amount from the transaction currency to the pricing currency. If you want to fetch exchange rate from the **CI\_TXN\_DETAIL** table, you need to create an algorithm using the **C1\_EXCRTOVRD** algorithm type and attach it to the **Exchange Rate Override Algorithm** parameter in the algorithm which is created using the **C1\_EXCRTTFM** algorithm type.

The **C1\_EXCRTOVRD** algorithm type contains the following parameters:

Parameter	Description	Mandatory (Yes or No)
Transaction Detail Field for Exchange Rate	Used to indicate the column of the <b>CI_TXN_DETAIL</b> table from where the exchange rate must be picked during currency conversion.	Yes

### Related Topics

<b>For more information on...</b>	<b>See...</b>
C1_EXCRTTFM algorithm type	<a href="#">C1_EXCRTTFM</a> on page 826

## Exchange Rate (Used for Searching)

You can define date or date and time based global and division-specific exchange rates. The date based exchange rate means that the exchange rate is applicable throughout the day. However, the date and time based exchange rate means that the exchange rate is applicable from that date and time onwards. The global exchange rate can be used for all divisions, whereas the division-specific exchange range can only be used for the division for which the exchange rate is defined.

**Note:** At present, time is not passed as input from any module (such as, payments, adjustments, billing, transaction feed management, and so on) during currency conversion. Therefore, even if you define date and time based exchange rates and use the date and time based currency conversion algorithms at the division level, the system will not search date and time based exchange rate when multiple exchange rates are available on the same day. The system will randomly pick an exchange rate on that day. The implementation team has to build the custom logic to pass or input time to the date and time based currency conversion algorithms in order to derive the appropriate exchange rate.

The system might use the direct division-specific or global exchange rate (i.e. FROM CCY to TO CCY) or direct reverse division-specific or global exchange rate (i.e. TO CCY to FROM CCY) during currency conversion. If either direct or direct reverse exchange rate is not available, the system might use division-specific or global exchange rate through base currency during currency conversion. For example, if the FROM CCY is Canadian Dollars, TO CCY is Japanese Yen, and the division's base currency is U.S. Dollars, the system will first convert the amount from Canadian Dollars to U.S. Dollars and then convert the amount from U.S. Dollars to Japanese Yen. You can define the order in which exchange rate must be searched in the currency conversion algorithm.

The **Exchange Rate** screen allows you to search for date or date and time based global and division-specific exchange rate using various search criteria. It also allows you to define, edit, and delete an exchange rate. This screen consists of the following zones:

- [Search Exchange Rate](#) on page 832

## Search Exchange Rate

The **Search Exchange Rate** zone allows you to search for an exchange rate using various search criteria. This zone contains the following two sections:

- **Search Criteria** — The **Search Criteria** section contains the following fields:

Field Name	Field Description	Mandatory (Yes or No)
Search By	Used to indicate whether you want to search date or date and time based exchange rates. The valid values are: <ul style="list-style-type: none"> <li>• Date/Time and Exchange Rate Source</li> <li>• Date</li> </ul> <p><b>Note:</b> By default, the <b>Date/Time and Exchange Rate Source</b> option is selected.</p>	Yes
From Currency	Used to search exchange rates with a particular source currency.	No
To Currency	Used to search exchange rates with a particular target currency.	No



Field Name	Field Description	Mandatory (Yes or No)
Division	Used to search exchange rates which are defined for a particular division.  <b>Note:</b> You can only view those divisions to which you have access in the <b>Division</b> list.	No
Conversion Type	Used to search exchange rates which are defined using a particular conversion type.	No
Effective Start Date/Time	Used to search exchange rates which are effective from a particular date and time onwards.  <b>Note:</b> This field appears only when you select the <b>Date/Time and Exchange Rate Source</b> option from the <b>Search By</b> list.	No
Effective End Date/Time	Used to search exchange rates which are effective till a particular date and time.  <b>Note:</b> This field appears only when you select the <b>Date/Time and Exchange Rate Source</b> option from the <b>Search By</b> list.	No
Effective Start Date	Used to search exchange rates which are effective from a particular date onwards.  <b>Note:</b> This field appears only when you select the <b>Date</b> option from the <b>Search By</b> list.	No
Effective End Date	Used to search exchange rates which are effective till a particular date.  <b>Note:</b> This field appears only when you select the <b>Date</b> option from the <b>Search By</b> list.	No
Exchange Rate Source	Used to search exchange rates which are received from a particular source.  <b>Note:</b> This field appears only when you select the <b>Date/Time and Exchange Rate Source</b> option from the <b>Search By</b> list.	No

**Note:** You must specify at least one search criterion while searching for an exchange rate.

- **Search Results** — On clicking the **Search** button, the search results appear based on the specified search criteria. The **Search Results** section contains the following columns:

Column Name	Column Description
Exchange Rate ID	Displays the exchange rate ID.  <b>Note:</b> It has a link. On clicking the link, the <b>Exchange Rate</b> screen appears with the details of the respective exchange rate.

Column Name	Column Description
From Currency	Indicates the currency which is translated. In other words, it is the source currency.
To Currency	Indicates the currency in which the source currency is translated. In other words, it is the target currency.
Division	Indicates the division for which the exchange rate is defined.  <b>Note:</b> The data does not appear in this column when the exchange rate is a global exchange rate.
Exchange Rate Source	Indicates the source from where the exchange rate is received.  <b>Note:</b> This column appears only when you select the <b>Date/Time and Exchange Rate Source</b> option from the <b>Search By</b> list.
Conversion Type	Indicates the conversion type of the exchange rate.
Effective Start Date/Time	Displays the date and time from when the exchange rate is effective.  <b>Note:</b> This column appears only when you select the <b>Date/Time and Exchange Rate Source</b> option from the <b>Search By</b> list.
Effective End Date/Time	Displays the date and time till when the exchange rate is effective.  <b>Note:</b> This column appears only when you select the <b>Date/Time and Exchange Rate Source</b> option from the <b>Search By</b> list. The data does not appear in this column when the exchange rate is a global exchange rate. This is because a global exchange rate does not have an end date and time.
Effective Start Date	Displays the date from when the exchange rate is effective.  <b>Note:</b> This column appears only when you select the <b>Date</b> option from the <b>Search By</b> list.
Effective End Date	Displays the date till when the exchange rate is effective.  <b>Note:</b> This column appears only when you select the <b>Date</b> option from the <b>Search By</b> list. The data does not appear in this column when the exchange rate is a global exchange rate. This is because a global exchange rate does not have an end date.
Exchange Rate	Displays the exchange rate.
Spread	Indicates the spread for the exchange rate.
Inverse Rate	Displays the reverse exchange rate.
Edit	On clicking the <b>Edit</b> (✎) icon, the <b>Add/Edit Exchange Rate</b> screen appears where you can edit the details of the exchange rate.
Delete	On clicking the <b>Delete</b> (🗑) icon, you can delete the exchange rate.

**Note:**

If you specify the effective start date and time while searching for an exchange rate, the system searches exchange rates which are effective from the specified date and time onwards. Let us understand this with the help of an example. The following table lists the exchange rates which are defined in the system where the From Currency is USD, To Currency is INR, and Division is D1:

Exchange Rate	Effective Start Date and Time	Effective End Date and Time
RT1	01-01-2014 12:00:00 PM	-
RT2	02-01-2014 12:00:00 PM	-
RT3	03-01-2014 12:00:00 PM	-

Now, when you search for exchange rates using the following search criteria, the system accordingly displays the search results:

Search Criteria	Search Results
Effective Start Date and Time: 01-01-2014 12:00:00 PM	All three exchange rates — RT1, RT2, and RT3 — will appear in the search results.
Effective Start Date and Time: 01-01-2014 12:00:00 PM; Effective End Date and Time: 31-01-2014 22:00:00 PM	RT1 will appear in the search results.
Effective Start Date and Time: 01-01-2014 12:00:00 PM; Effective End Date and Time: 02-01-2014 22:00:00 PM	RT1 and RT2 will appear in the search results.
Effective Start Date and Time: 02-01-2014 12:00:00 PM	RT2 and RT3 will appear in the search results.
Effective Start Date and Time: 02-01-2014 12:00:00 PM; Effective End Date and Time: 02-28-2014 22:00:00 PM	RT2 will appear in the search results.
Effective Start Date and Time: 03-01-2014 12:00:00 PM	RT3 will appear in the search results.

**Related Topics**

For more information on...	See...
How to search for an exchange rate	<a href="#">Searching for an Exchange Rate</a> on page 835
How to view the details of an exchange rate	<a href="#">Viewing the Exchange Rate Details</a> on page 846
How to define an exchange rate	<a href="#">Defining an Exchange Rate</a> on page 836
How to edit an exchange rate	<a href="#">Editing an Exchange Rate</a> on page 840
How to delete an exchange rate	<a href="#">Deleting an Exchange Rate</a> on page 842

**Searching for an Exchange Rate****Prerequisites**

To search for an exchange rate, you should have:

- Currencies and divisions defined in the application

- Conversion types defined in the **CONV\_TYPE\_FLG** lookup field
- Exchange rate sources defined in the **EXCH\_RATE\_SRC\_FLG** lookup field

### **Procedure**

To search for an exchange rate:

1. Click the **Menu** link in the **Application** toolbar.  
A list appears.
2. From the **Main** menu, select **Pricing Management** and then click **Exchange Rate**.  
A sub-menu appears.
3. Click the **Search** option from the **Exchange Rate** sub-menu.  
The **Exchange Rate** screen appears.
4. Select the required option from the **Search By** list depending on whether you want to search date or date and time based exchange rates.
5. Enter the search criteria in the **Search Exchange Rate** zone.

**Note:** ORMB search engine supports wildcard search, where you can substitute the percentage (%) symbol as a stand in for any word or letter in a search criteria. You can use the ‘%’ wildcard character in all the input fields except the date fields. The ‘%’ wildcard character is suffixed automatically at the end of the partial search criteria. Therefore, you may or may not specify the wildcard character at the end of the partial search criteria. However, you have to prefix the wildcard character manually wherever required.

6. Click **Search**.

A list of exchange rates that meet the search criteria appears in the **Search Results** section.

### **Related Topics**

<b>For more information on...</b>	<b>See...</b>
<b>Exchange Rate</b> screen	<a href="#">Exchange Rate (Used for Searching)</a> on page 832
<b>Search Exchange Rate</b> zone	<a href="#">Search Exchange Rate</a> on page 832

## **Defining an Exchange Rate**

### **Prerequisites**

To define an exchange rate, you should have:

- Determine Business Object algorithm defined using the **F1-MOBO** algorithm type and attached to the **C1\_EXCHRATE** maintenance object

**Note:** The **C1-ExchangeRate** and **C1\_EXCHRATE\_BO** business objects are shipped with the product. The **C1-ExchangeRate** business object is used while defining and editing date and time based exchange rates. However, the **C1\_EXCHRATE\_BO** business object is used while defining and editing date based exchange rates. Depending on whether you want to define date or date and time based exchange rates, you need to accordingly set the **Business Object** parameter in the Determine Business Object algorithm. The system will then accordingly display the fields while defining or editing an exchange rate.

- Currencies and divisions defined in the application
- Conversion types defined in the **CONV\_TYPE\_FLG** lookup field
- Exchange rate sources defined in the **EXCH\_RATE\_SRC\_FLG** lookup field

**Procedure**

To define an exchange rate:

1. Click the **Menu** link in the **Application** toolbar.  
A list appears.
2. From the **Main** menu, select **Pricing Management** and then click **Exchange Rate**.  
A sub-menu appears.
3. Click the **Add** option from the **Exchange Rate** sub-menu.

The **Add/Edit Exchange Rate** screen appears. It contains the following fields:

Field Name	Field Description	Mandatory (Yes or No)
Business Object	Indicates the business object using which you are defining an exchange rate.	Not applicable
From Currency	Used to indicate the currency that you want to translate. In other words, it is used to indicate the source currency.	Yes
To Currency	Used to indicate the currency in which you want to translate the source currency. In other words, it is used to indicate the target currency.	Yes
Conversion Type	Used to indicate the conversion type for the exchange rate.	Yes
Division	Used to indicate the division for which you want to define the exchange rate.  <b>Note:</b> You can only view those divisions to which you have access in the <b>Division</b> list.  You must leave this field blank while defining a global exchange rate.	Yes (Conditional)  <b>Note:</b> This field is required when you are defining a division-specific exchange rate.
Exchange Rate Source	Used to indicate the source from where the exchange rate is received.  <b>Note:</b> This field appears only when you are defining a date and time based exchange rate.	No
Effective Start Date/Time	Used to specify the date and time from when the exchange rate is effective.  <b>Note:</b> This field appears only when you are defining a date and time based exchange rate.  By default, the time is set to 12:00 AM. You can change the time, if required.	Yes

Field Name	Field Description	Mandatory (Yes or No)
Effective End Date/ Time	Used to specify the date and time till when the exchange rate is effective.  <b>Note:</b> The effective end date and time cannot be earlier than the effective start date and time. You must leave this field blank while defining a global exchange rate. This is because a global exchange rate does not have an end date and time. This field appears only when you are defining a date and time based exchange rate. By default, the time is set to 12:00 AM. You can change the time, if required.	Yes (Conditional)  <b>Note:</b> If the <b>End Date Required for Division Override</b> option type of the <b>C1_EXCHRATE</b> feature configuration is set to <b>Y</b> , this field is required when you are defining a division-specific exchange rate.
Effective Start Date	Used to specify the date from when the exchange rate is effective.  <b>Note:</b> This field appears only when you are defining a date based exchange rate.	Yes
Effective End Date	Used to specify the date till when the exchange rate is effective.  <b>Note:</b> The effective end date cannot be earlier than the effective start date. You must leave this field blank while defining a global exchange rate. This is because a global exchange rate does not have an end date. This field appears only when you are defining a date based exchange rate.	Yes (Conditional)  <b>Note:</b> If the <b>End Date Required for Division Override</b> option type of the <b>C1_EXCHRATE</b> feature configuration is set to <b>Y</b> , this field is required when you are defining a division-specific exchange rate.
Exchange Rate	Used to specify the exchange rate. In other words, it is the number of units of the target currency that is equivalent to a single unit of the source currency.  <b>Note:</b> The system provides you with the facility to specify the exchange rate value with a precision of upto 18 decimal places (0.000000000000000001).	Yes
Spread	Used to specify the spread for the exchange rate.	No

**Tip:** Alternatively, you can access the **Add/Edit Exchange Rate** screen by clicking the **Add Exchange Rate** button in the **Page Title** area of the **Exchange Rate** screen.

4. Enter the required details in the **Add/Edit Exchange Rate** screen.
5. Define characteristics for the exchange rate, if required.

**Note:** You can define characteristics only when you are defining a date and time based exchange rate.

6. Click **Save**.

The exchange rate is defined in the system.

**Note:** If an exchange rate is already defined with a source and conversion type combination on a given date and time, the system will not allow you to define another exchange rate with the same specifications.

### **Related Topics**

<b>For more information on...</b>	<b>See...</b>
<b>Exchange Rate</b> screen	<a href="#">Exchange Rate (Used for Searching)</a> on page 832
<b>Search Exchange Rate</b> zone	<a href="#">Search Exchange Rate</a> on page 832
How to define characteristics for an exchange rate	<a href="#">Defining Characteristics for an Exchange Rate</a> on page 839
How to set the <b>C1_EXCHRATE</b> feature configuration	<a href="#">Setting the C1_EXCHRATE Feature Configuration</a> on page 2908

## **Defining Characteristics for an Exchange Rate**

### **Prerequisites**

To define characteristics for an exchange rate, you should have:

- Characteristic types defined in the application (where the characteristic entity is set to **Exchange Rate**)

### **Procedure**

To define characteristics for an exchange rate:

1. Ensure that the **Characteristics** section is expanded when you are defining or editing an exchange rate.

The **Characteristics** section contains the following fields:

<b>Field Name</b>	<b>Field Description</b>	<b>Mandatory (Yes or No)</b>
Effective Date	Used to specify the date from when the characteristic is effective for the exchange rate.	Yes (Conditional) <b>Note:</b> This field is required when you are defining a characteristic for the exchange rate.
Characteristic Type	Used to indicate the characteristic type. <b>Note:</b> The list includes only those characteristic types where the characteristic entity is set to <b>Exchange Rate</b> .	Yes (Conditional) <b>Note:</b> This field is required when you are defining a characteristic for the exchange rate.

Field Name	Field Description	Mandatory (Yes or No)
Characteristic Value	Used to specify the value for the characteristic type.  <b>Note:</b> On specifying the value for a predefined characteristic type, the description of the characteristic value appears corresponding to the <b>Characteristic Value</b> field.	Yes (Conditional)  <b>Note:</b> This field is required when you are defining a characteristic for the exchange rate.

**Note:** The **Characteristics** section appears only when you are defining or editing a date and time based exchange rate.

- Enter the required details in the **Characteristics** section.

**Note:** If you select a predefined characteristic type, the **Search**  icon appears corresponding to the **Characteristic Value** field. On clicking the **Search** icon, you can search for a predefined characteristic value.

- If you want to define more than one characteristic for the exchange rate, click the **Add**  icon and then repeat step 2.

**Note:** However, if you want to remove a characteristic from the exchange rate, click the **Delete**  icon corresponding to the characteristic.

### Related Topics

For more information on...	See...
How to define an exchange rate	<a href="#">Defining an Exchange Rate</a> on page 836
How to edit an exchange rate	<a href="#">Editing an Exchange Rate</a> on page 840

## Editing an Exchange Rate

### Procedure

To edit an exchange rate:

- Search for the exchange rate in the **Exchange Rate** screen.
- In the **Search Results** section, click the **Edit**  icon in the **Edit** column corresponding to the exchange rate whose details you want to edit.

The **Add/Edit Exchange Rate** screen appears. It contains the following fields:

Field Name	Field Description	Mandatory (Yes or No)
Exchange Rate ID	Displays the exchange rate ID.	Not applicable
Business Object	Indicates the business object used while defining an exchange rate.	Not applicable
From Currency	Indicates the currency which is translated. In other words, it is the source currency.	Not applicable
To Currency	Indicates the currency in which the source currency is translated. In other words, it is the target currency.	Not applicable



Field Name	Field Description	Mandatory (Yes or No)
Conversion Type	Indicates the conversion type of the exchange rate.	Not applicable
Division	Indicates the division for which the exchange rate is defined.  <b>Note:</b> The data does not appear corresponding to this field when the exchange rate is a global exchange rate.	Not applicable
Exchange Rate Source	Indicates the source from where the exchange rate is received.  <b>Note:</b> This field appears only when you are editing a date and time based exchange rate.	Not applicable
Effective Start Date/Time	Displays the date and time from when the exchange rate is effective.  <b>Note:</b> This field appears only when you are editing a date and time based exchange rate.	Not applicable
Effective End Date/Time	Used to specify the date and time till when the exchange rate is effective.  <b>Note:</b> The effective end date and time cannot be earlier than the effective start date and time. This field appears only when you are editing a date and time based exchange rate. This field is non-editable when you are editing a date and time based global exchange rate. This is because a global exchange rate does not have an end date and time.	Yes (Conditional)  <b>Note:</b> If the <b>End Date Required for Division Override</b> option type of the <b>C1_EXCHRATE</b> feature configuration is set to <b>Y</b> , this field is required when you are defining a division-specific exchange rate.
Effective Start Date	Displays the date from when the exchange rate is effective.  <b>Note:</b> This field appears only when you are editing a date based exchange rate.	Not applicable

Field Name	Field Description	Mandatory (Yes or No)
Effective End Date	Used to specify the date till when the exchange rate is effective.  <b>Note:</b> The effective end date cannot be earlier than the effective start date. This field appears only when you are editing a date based exchange rate. This field is non-editable when you are editing a date based global exchange rate. This is because a global exchange rate does not have an end date.	Yes (Conditional)  <b>Note:</b> If the <b>End Date Required for Division Override</b> option type of the <b>C1_EXCHRATE</b> feature configuration is set to <b>Y</b> , this field is required when you are defining a division-specific exchange rate.
Exchange Rate	Used to specify the exchange rate. In other words, it is the number of units of the target currency that is equivalent to a single unit of the source currency.  <b>Note:</b> The system provides you with the facility to specify the exchange rate value with a precision of upto 18 decimal places (0.000000000000000001).	Yes
Spread	Used to specify the spread for the exchange rate.	No

**Tip:** Alternatively, you can click the **Edit** button in the **Exchange Rate** zone to edit the details of the exchange rate.

3. Modify the required details in the **Add/Edit Exchange Rate** screen.
4. Define, edit, or remove characteristics from the exchange rate, if required.

**Note:** The **Characteristics** section appears only when you are editing a date and time based exchange rate.

5. Click **Save**.

The changes made to the exchange rate are saved.

### **Related Topics**

For more information on...	See...
How to search for an exchange rate	<a href="#">Searching for an Exchange Rate</a> on page 835
<b>Exchange Rate</b> zone	<a href="#">Exchange Rate</a> on page 843
How to set the <b>C1_EXCHRATE</b> feature configuration	<a href="#">Setting the C1_EXCHRATE Feature Configuration</a> on page 2908

## **Deleting an Exchange Rate**

### **Procedure**

To delete an exchange rate:

1. Search for the exchange rate in the **Exchange Rate** screen.

- In the **Search Results** section, click the **Delete** (🗑️) icon in the **Delete** column corresponding to the exchange rate that you want to delete.

A message appears confirming whether you want to delete the exchange rate.

**Tip:** Alternatively, you can click the **Delete** button in the **Exchange Rate** zone to delete the exchange rate.

- Click **OK**.

The exchange rate is deleted.

### Related Topics

For more information on...	See...
How to search for an exchange rate	<a href="#">Searching for an Exchange Rate</a> on page 835

## Exchange Rate (Used for Viewing)

---

Once you define an exchange rate, the **Exchange Rate** screen allows you to:

- Edit the details of the exchange rate
- Delete the exchange rate
- View the details of the exchange rate
- View the log of the exchange rate

This screen consists of the following zones:

- [Exchange Rate](#) on page 843
- [Exchange Rate Log](#) on page 845

### Exchange Rate

The **Exchange Rate** zone displays the details of the exchange rate. This zone contains the following sections:

- Main** — This section provides basic information about the exchange rate. It contains the following fields:

Field Name	Field Description
Exchange Rate ID	Displays the exchange rate ID.
From Currency	Indicates the currency which is translated. In other words, it is the source currency.
To Currency	Indicates the currency in which the source currency is translated. In other words, it is the target currency.
Conversion Type	Indicates the conversion type of the exchange rate.

Field Name	Field Description
Division	<p>Indicates the division for which the exchange rate is defined.</p> <p><b>Note:</b> The data does not appear corresponding to this field when the exchange rate is a global exchange rate. It has a link. On clicking the link, the <b>Division</b> screen appears with the details of the respective division.</p>
Exchange Rate Source	<p>Indicates the source from where the exchange rate is received.</p> <p><b>Note:</b> This field appears only when you are viewing the details of a date and time based exchange rate.</p>
Effective Start Date/ Time	<p>Displays the date and time from when the exchange rate is effective.</p> <p><b>Note:</b> This field appears only when you are viewing the details of a date and time based exchange rate.</p>
Effective End Date/ Time	<p>Displays the date and time till when the exchange rate is effective.</p> <p><b>Note:</b> This field appears only when you are viewing the details of a date and time based exchange rate. The data does not appear corresponding to this field when the exchange rate is a global exchange rate. This is because a global exchange rate does not have an end date and time.</p>
Effective Start Date	<p>Displays the date from when the exchange rate is effective.</p> <p><b>Note:</b> This field appears only when you are viewing the details of a date based exchange rate.</p>
Effective End Date	<p>Displays the date till when the exchange rate is effective.</p> <p><b>Note:</b> This field appears only when you are viewing the details of a date based exchange rate. The data does not appear corresponding to this field when the exchange rate is a global exchange rate. This is because a global exchange rate does not have an end date.</p>
Exchange Rate	Displays the exchange rate.
Spread	Indicates the spread for the exchange rate.

- **Characteristics** — This section lists the characteristics defined for the exchange rate. It contains the following columns:

Column Name	Column Description
Effective Date	Indicates the date from when the characteristic is effective for the exchange rate.
Characteristic Type	Indicates the characteristic type.

Column Name	Column Description
Characteristic Value	Displays the value of the characteristic type.

**Note:** The **Characteristics** section appears only when you are viewing the details of a date and time based exchange rate.

- **Record Actions** — This section contains the following buttons:

Button Name	Button Description
Edit	Used to edit the details of the exchange rate.
Delete	Used to delete the exchange rate.

- **Record Information** — This section contains the following fields:

Field Name	Field Description
Business Object	Indicates the business object using which the exchange rate is created. In addition, a context menu appears corresponding to this field which helps in navigating to other screens in the application.  <b>Note:</b> It has a link. On clicking the link, the <b>Business Object</b> screen appears where you can view the details of the respective business object.
Create Date/Time	Displays the date and time when the exchange rate is created.

### Related Topics

For more information on...	See...
How to edit an exchange rate	<a href="#">Editing an Exchange Rate</a> on page 840
How to delete an exchange rate	<a href="#">Deleting an Exchange Rate</a> on page 842

## Exchange Rate Log

The **Exchange Rate Log** zone lists the complete trail of actions performed on the exchange rate. It contains the following columns:

Column Name	Column Description
Date/Time	Displays the date and time when the action was performed on the exchange rate.
Details	Displays the details about the action performed on the exchange rate.
User	Indicates the user who has performed the action on the exchange rate.
Log Type	Indicates the type of the log.
Related Object	Indicates the object or entity which is generated when the action is performed on the exchange rate.  <b>Note:</b> At present, no data appears in this column. The implementation team can build the custom logic to meet the business requirements.

Column Name	Column Description
Status Reason	Indicates the reason why the status was changed.  <b>Note:</b> At present, no data appears in this column. The implementation team can create a custom exchange rate business object with the status lifecycle.

## Viewing the Exchange Rate Details

### Procedure

To view the details of an exchange rate:

1. Search for the exchange rate in the **Exchange Rate** screen.
2. In the **Search Results** section, click the link in the **Exchange Rate ID** column corresponding to the exchange rate whose details you want to view.

The **Exchange Rate** screen appears. It contains the following zones:

- **Exchange Rate** — Displays the details of the exchange rate.
  - **Exchange Rate Log** — Lists the complete trail of actions performed on the exchange rate.
3. View the details of the exchange rate in the **Exchange Rate** zone.
  4. View the log of the exchange rate in the **Exchange Rate Log** zone.

### Related Topics

For more information on...	See...
How to search for an exchange rate	<a href="#">Searching for an Exchange Rate</a> on page 835
<b>Exchange Rate</b> screen	<a href="#">Exchange Rate (Used for Viewing)</a> on page 843
<b>Exchange Rate</b> zone	<a href="#">Exchange Rate</a> on page 843
<b>Exchange Rate Log</b> zone	<a href="#">Exchange Rate Log</a> on page 845

---

# Chapter 11

---

## Transaction Feed Management

---

### Topics:

- [Prerequisites](#)
- [Transaction Rating Before Billing](#)
- [Transaction Aggregation](#)
- [Transaction Aggregation Batch Processing](#)
- [Transaction Disaggregation](#)
- [Transaction Disaggregation Batch Processing](#)
- [Reseeding](#)
- [Transaction Cancellation](#)
- [Transaction Cancellation Batch Processing](#)
- [Transaction Rollback](#)
- [Feed Status Transition](#)
- [Transaction Status Transition](#)
- [Transaction Leg Status Transition](#)
- [Transaction Data File](#)
- [Error List](#)
- [Feed Management Dashboard](#)
- [View Billed Transactions](#)
- [Transaction Details](#)
- [Transaction Source](#)
- [Transaction Record Type](#)
- [Transaction Aggregation Rule](#)
- [Schedule](#)
- [Disaggregation Request](#)
- [Accumulation Data](#)

Oracle Revenue Management and Billing provides you with a facility to upload banking and Administrative Services Only (ASO) transactions received from various product processors or applications for billing. You can use the **File Upload Interface** feature to upload transaction data files in the following formats:

- Comma Separated Values
- JavaScript Object Notation
- Fixed Position
- Pipe Separated Values
- Tilde Separated Values
- Extensible Markup Language

For more information on how to upload the data using the **File Upload Interface** feature, refer to the respective feature documentation. Once the transaction data is uploaded in the system, you need to:

- Validate Header Details
- Validate Transaction Details and Determine Initial Product
- Verify Price Item Pricing
- Rate Transactions Before Billing (if required)
- Create and Update Billable Charge with the SQI values
- Clean-up Unwanted Data

The system provides the flexibility to rate the transactions either prior to billing or during billing. Based on the business requirements, you can configure the system such that transactions mapped to some price item can be rated at a frequency which is different than the account's billing frequency. For example, daily, weekly, etc. During the transaction feed management process, each transaction goes through various statuses until it is billed to the person. For more information about the transaction statuses, see [Transaction Status Transition](#) on page 902.

The transaction feed management process includes the following sub-processes:

- [Transaction Aggregation](#)
- [Transaction Disaggregation](#) on page 884
- [Transaction Cancellation](#) on page 895
- [Transaction Rollback](#) on page 899

## Prerequisites

---

To setup the transaction feed management process, you need to do the following:

- Define the required transaction sources in the system
- Define the required transaction record types for each transaction source
- Associate the required SQIs with a price item —division combination
- Define the required transaction aggregation rule for each SQI
- Define the aggregation schedules in the system
- Define the required rules in the system to determine initial price item for transactions
- Attach a validation algorithm to each account identifier type (to ensure that the account identifier type and account identifier combination is unique in or across divisions)
- Attach the **Price Assignment Search** algorithm to each division
- Define the **TFM - Processing Date** characteristic for each division
- Create an algorithm of the **C1\_CURALGTFM** algorithm type and attach it to the **TFM - Currency Conversion** algorithm spot of the division for which you want to enable the currency conversion feature
- Define the required exchange rates for currency conversion
- Define values for the PAGE\_NUMBER lookup field
- Create an algorithm of the **C1\_RTCL\_POPC** algorithm type and attach it to the **TFM - Rate Post-Processing** algorithm spot of the required division

Besides this, you need to setup the following feature configurations:

- *Rule Engine (CI\_RLENG)*
- *Dummy Header (CI-TXNDMYID)*
- *Multi Parameter Based Pricing (CI\_PPARAM\_FLG)*
- *Feed Management (CI\_FM)*

## Transaction Rating Before Billing

---

The system provides the flexibility to rate the transaction legs either prior to billing or during billing. Based on the business requirements, you can configure the system such that transactions mapped to some price items can be rated at a frequency which is different than the account's billing frequency. For example, daily, weekly, etc. This will help to reduce the performance issues which are caused when large volume of transactions are rated at the time of billing.

The system offers the following ways in which a transaction leg can be priced, rated and billed:

1. **Rate the Transaction Leg During Billing** – In this approach, you can use either of the following ways:
  - a. Determine effective pricing for a transaction leg, create a billable charge for the transaction leg, and then determine the rate during billing.
  - b. Determine effective pricing for a transaction leg, create a billable charge for aggregated transaction legs, and then determine the rate during billing.
2. **Rate the Transaction Leg Prior to Billing** – In this approach, you can use either of the following ways:
  - a. Determine effective pricing and rate for a transaction leg, and accumulate pre-calculated charges in a pass through billable charge based on the distribution code, currency code, description on bill, aggregation



parameter group ID (which is created based on the rate component characteristics). The pass through billable charge is then billed during billing.

- b. Determine effective pricing for a transaction leg, aggregate the transaction legs, determine rate for aggregated service quantities, and then accumulate pre-calculated charges in a pass through billable charge based on the distribution code, currency code, description on bill, aggregation parameter group ID (which is created based on the rate component characteristics). The pass through billable charge is then billed during billing.
- c. Determine effective pricing and rate for a transaction leg and create a pass through billable charge for the transaction leg which is billed during billing.

**3. Ignore the Transaction Leg for Billing** – In this approach, you can use either of the following ways:

- a. Determine effective pricing for a transaction leg, but the billable charge is not created for the transaction leg.
- b. Determine effective pricing and rate for a transaction leg, but the billable charge is not created for the transaction leg.

**Note:**

Once the rate is determined for transaction legs, a set of rate component characteristics and their values are grouped. For example, if a price assignment has the following rate components, the system creates two groups — Group A and Group B:

- RC1, Char1=Y, Char2=Y
- RC2, Char1=N, Char2=Y
- RC3, Char1=Y, Char2=Y

Group A contains Char1=Y, Char2=Y and Group B contains Char1=N, Char2=Y. These groups are used for accumulating pre-calculated charges. A unique aggregation parameter group ID is generated for each group. If a group with a set of rate component characteristics and their values already exists in the system, a new group is not created. Instead, the existing group is used for accumulating pre-calculated charges. The aggregation parameter group ID is created only when you attach an algorithm of the **C1\_RTCL\_POPC** algorithm type on the **TFM - Rate Post-Processing** algorithm entity in the **Algorithms** tab of the **Division** screen. Note that the system invokes the algorithm which is attached on the derived account's division and not on the division to which the transaction belongs.

While defining a price item pricing, you need to specify the rating criteria which indicates how and when you want to rate the transaction legs. The valid values are:

- Do Not Rate Transactions (DNRT)
- Aggregate transactions and then rate aggregated SQs (AGTR)
- Rate individual transactions and aggregate calc lines across transactions (RITA)
- Rate Transactions (RITX)

Along with the **Rating Criteria** field, the **Ignore Transaction** and **Aggregate Transaction** fields help the system to determine how and when the corresponding transaction leg must be rated. The following table indicates how to configure the system in order to use the above mentioned ways:

Transaction Rating Approach and Way	Ignore Transaction (Yes or No)	Aggregate Transaction (Yes or No)	Rating Criteria	Batch in which the Rate is Determined
3a	Yes	Not applicable	Do Not Rate Transactions (DNRT)	Not applicable because ignored transactions are not considered for billing.

Transaction Rating Approach and Way	Ignore Transaction (Yes or No)	Aggregate Transaction (Yes or No)	Rating Criteria	Batch in which the Rate is Determined
3b	Yes	Not applicable	Rate Transactions (RITX)	Update Status (C1-TXNEX)
1b	No	Yes	Do Not Rate Transactions (DNRT)	Not applicable because the rate is determined during billing.
2b	No	Yes	Aggregate transactions and then rate aggregated SQs (AGTR)	Service Quantity Calculation (C1-TXNSQ)
2a	No	Yes	Rate individual transactions and aggregate calc lines across transactions (RITA)	Update Status (C1-TXNEX)
1a	No	No	Do Not Rate Transactions (DNRT)	Not applicable because the rate is determined during billing.
2c	No	No	Rate Transactions (RITX)	Service Quantity Calculation (C1-TXNSQ)

Let us understand the following transaction rating ways with the help of an example:

- 2a
- 2b
- 2c

The following table lists the account, price item, and price item parameters combination to which transaction T1 and T2 are mapped:

Transaction	Transaction Volume	Transaction Date	Account	Price Item	Price Item Parameter Group ID	Price Assignment ID	Aggregation Schedule
T1	300	01/01/2015	A1	P1	PG1	PA1	Monthly
T1	300	01/01/2015	A2	P1	PG1	PA2	Monthly
T2	200	15/01/2015	A1	P1	PG1	PA1	Monthly
T2	200	15/01/2015	A3	P1	PG1	PA3	Monthly

The following table lists the rate components available on the PA1, PA2, and PA3 price assignments:

Transaction	Price Assignment ID	Rate Component	Currency Code	Distribution Code	Description on Bill	Aggregation Parameter Group ID (Rate Component's Characteristics)
T1	PA1	RC1-0.1*Transaction Volume	USD	BK-AR1	XYZ	Char1=Y
T1	PA1	RC2-0.2*Transaction Volume	USD	BK-AR2	ABC	Char2=Y
T1	PA2	RC3-0.3*Transaction Volume	USD	BK-AR3	XYZ	Char1=Y
T1	PA2	RC4-0.2*Transaction Volume	USD	BK-AR4	ABC	Char2=Y
T2	PA1	RC1-0.1*Transaction Volume	USD	BK-AR1	XYZ	Char1=Y
T2	PA1	RC2-0.2*Transaction Volume	USD	BK-AR2	ABC	Char2=Y
T2	PA3	RC3-0.3*Transaction Volume	USD	BK-AR3	XYZ	Char1=Y
T2	PA3	RC4-0.2*Transaction Volume	USD	BK-AR3	XYZ	Char1=Y

Now, if you use **RITA (2a)** approach, the system will rate a transaction leg and accumulate pre-calculated charges in a pass through billable charge based on the distribution code, currency code, description on bill, aggregation parameter group ID, as shown in the following table:

Billable Charge	Start Date	End Date	Transaction Leg	Rate Component	Calculation Details	Pass Through Charge (\$)	Comments
BC1	01/01/2015	31/01/2015	T1- A1P1PG1- PA1, T2- A1P1PG1- PA1	RC1	$300*0.1 = 30$ , $200*0.1 = 20$	$30+20 = 50$	The pass through charge is calculated for each transaction leg and then accumulated because the distribution code, currency code, description on bill, and characteristics of the rate components are same.

Billable Charge	Start Date	End Date	Transaction Leg	Rate Component	Calculation Details	Pass Through Charge (\$)	Comments
BC1	01/01/2015	31/01/2015	T1– A1P1PG1– PA1, T2– A1P1PG1– PA1	RC2	$300 * 0.2 = 60$ , $200 * 0.2 = 40$	$60 + 40 = 100$	The pass through charge is calculated for each transaction leg and then accumulated because the distribution code, currency code, description on bill, and characteristics of the rate components are same.
BC2	01/01/2015	31/01/2015	T1– A2P1PG1– PA2	RC3	$300 * 0.3 = 90$	90	The pass through charge is calculated for the transaction leg.
BC2	01/01/2015	31/01/2015	T1– A2P1PG1– PA2	RC4	$300 * 0.2 = 60$	60	The pass through charge is calculated for the transaction leg.
BC3	01/01/2015	31/01/2015	T2– A3P1PG1– PA3	RC3, RC4	$200 * 0.3 = 60$ , $200 * 0.2 = 40$	$60 + 40 = 100$	The pass through charges are calculated for the transaction leg and then accumulated because the distribution code, currency code, description on bill, and characteristics of the rate components are same.

In the above example, the BC1 and BC2 will have two pass through lines, whereas the BC3 will have one pass through line.

Now, if you use **RITX (2c)** approach, the system will rate a transaction leg and calculate charges for each transaction leg in a separate pass through billable charge, as shown in the following table:

Billable Charge	Start Date	End Date	Transaction Leg	Rate Component	Calculation Details	Pass Through Charge (\$)	Comments
BC1	01/01/2015	31/01/2015	T1-A1P1PG1-PA1	RC1	$300 * 0.1 = 30$	30	The pass through charge is calculated for the transaction leg.
BC1	01/01/2015	31/01/2015	T1-A1P1PG1-PA1	RC2	$300 * 0.2 = 60$	60	The pass through charge is calculated for the transaction leg.
BC2	01/01/2015	31/01/2015	T1-A2P1PG1-PA2	RC3	$300 * 0.3 = 90$	90	The pass through charge is calculated for the transaction leg.
BC2	01/01/2015	31/01/2015	T1-A2P1PG1-PA2	RC4	$300 * 0.2 = 60$	60	The pass through charge is calculated for the transaction leg.
BC3	01/01/2015	31/01/2015	T2-A1P1PG1-PA1	RC1	$200 * 0.1 = 20$	20	The pass through charge is calculated for the transaction leg.
BC3	01/01/2015	31/01/2015	T2-A1P1PG1-PA1	RC2	$200 * 0.2 = 40$	40	The pass through charge is calculated for the transaction leg.
BC4	01/01/2015	31/01/2015	T2-A3P1PG1-PA3	RC3, RC4	$200 * 0.3 = 60$ , $200 * 0.2 = 40$	$60 + 40 = 100$	The pass through charges are calculated for the transaction leg and then accumulated because the distribution code, currency code, description on bill, and characteristics of the rate components are same.

In the above example, the BC1, BC2, and BC3 will have two pass through lines, whereas the BC4 will have one pass through line.

Now, if you use **AGTR (2b)** approach, the system will determine effective pricing for a transaction leg, aggregate the transaction legs, determine rate for aggregated service quantities, and then accumulate pre-calculated charges in a pass through billable charge based on the distribution code, currency code, description on bill, aggregation parameter group ID (which is created based on the rate component characteristics), as shown in the following table:

Account- Price Item- Price Item Parameter Group- Price Assignment- Aggregation Schedule	Total Transaction Volume	Billable Charge	Start Date	End Date	Rate Component	Calculation Details	Pass Through Charge (\$)	Comments
A1P1PG1- PA1- Monthly	300+200 = 500	BC1	01/01/2015	31/01/2015	RC1	500*0.1 = 50	50	The transaction volume of T1 and T2 legs having the same price item and price item parameters combination and whose transaction date falls between the aggregation schedule is first aggregated and then pass through charge is calculated for aggregated service quantities.

Account- Price Item- Price Item Parameter Group- Price Assignment- Aggregation Schedule	Total Transaction Volume	Billable Charge	Start Date	End Date	Rate Component	Calculation Details	Pass Through Charge (\$)	Comments
A1P1PG1- PA1- Monthly	300+200 = 500	BC1	01/01/2015	31/01/2015	RC2	500*0.2 = 100	100	The transaction volume of T1 and T2 legs having the same price item and price item parameters combination and whose transaction date falls between the aggregation schedule is first aggregated and then pass through charge is calculated for aggregated service quantities.
A2P1PG1- PA2- Monthly	300	BC2	01/01/2015	31/01/2015	RC3	300*0.3 = 90	90	The pass through charge is calculated for the transaction leg.
A2P1PG1- PA2- Monthly	300	BC2	01/01/2015	31/01/2015	RC4	300*0.2 = 60	60	The pass through charge is calculated for the transaction leg.

Account- Price Item- Price Item Parameter Group- Price Assignment- Aggregation Schedule	Total Transaction Volume	Billable Charge	Start Date	End Date	Rate Component	Calculation Details	Pass Through Charge (\$)	Comments
A3P1PG1- PA3- Monthly	200	BC3	01/01/2015	31/01/2015	RC3, RC4	200*0.3 = 60, 200*0.2 = 40	60+40 = 100	The pass through charges are calculated for the transaction leg and then accumulated because the distribution code, currency code, description on bill, and characteristics of the rate components are same.

In the above example, the BC1 and BC2 will have two pass through lines, whereas the BC3 will have one pass through line.

## Transaction Aggregation

---

The transaction aggregation process includes the following sub-processes:

- [Header Validation](#) on page 857
- [Transaction Validation and Initial Price Item Determination](#) on page 859
- [Price Item Pricing Verification](#) on page 870
- [Aggregation](#) on page 875
- [Clean Up](#) on page 879

The following figure graphically explains the transaction aggregation process:



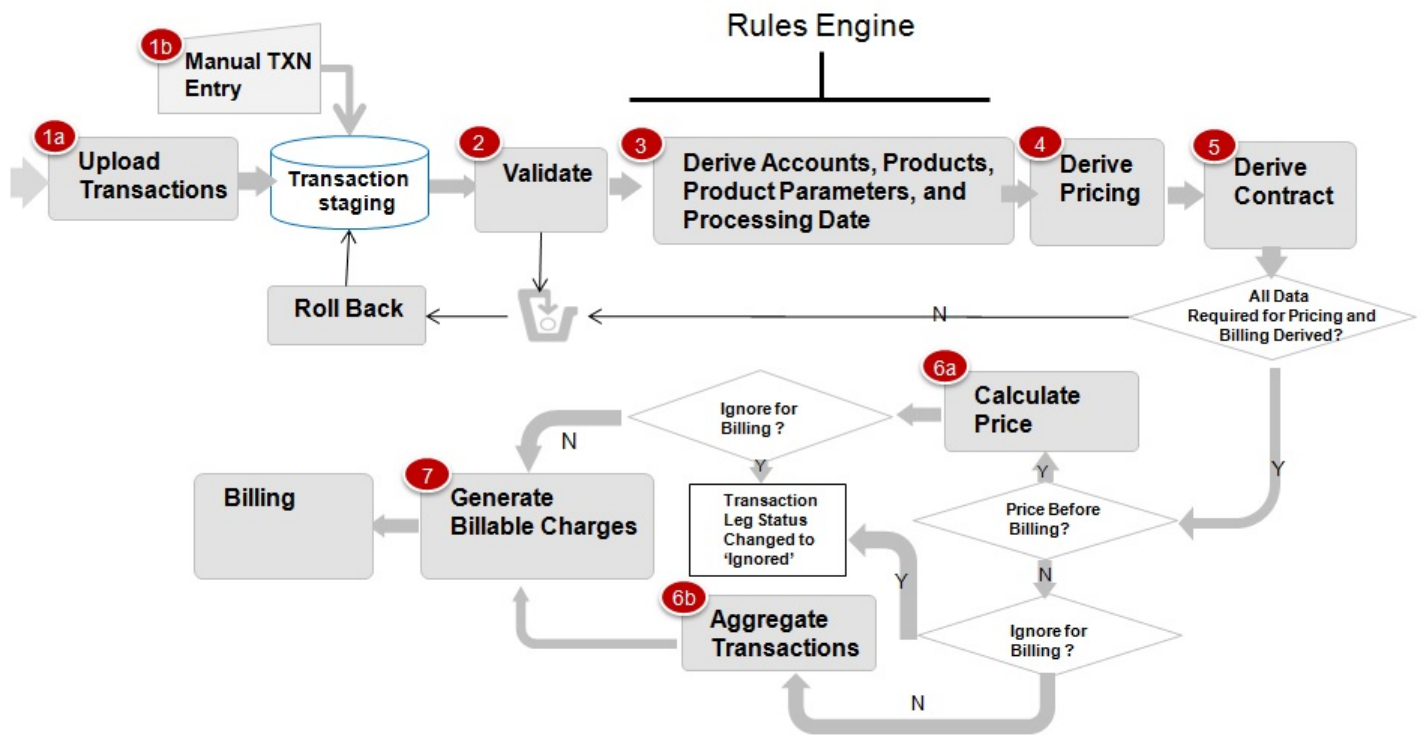

## Header Validation

Once the file is uploaded in the system, you can execute the **Header Validation (C1-TXNHV)** batch to validate the file or header level information. It checks whether:

- Transaction Header ID and Transaction Source is available in the header.
- At least one transaction record is available in the file.
- The number of transaction records in the file matches the total transaction records in the header.
- The sum of transaction amount matches the total transaction amount in the header.
- The sum of transaction volume matches the total transaction volume in the header.
- File with the same header date and transaction header ID is not available in the system.
- External reference number is specified in each transaction record of the file.

If the file or header information is validated successfully, the status of the file or feed is changed to **Validated (VALI)** and the status of all transactions in the feed remains as **Uploaded (UPLD)**. However, if the header validation fails, the status of the feed and all transactions in the feed is changed to **Invalid (INVL)**.

The **Header Validation (C1-TXNHV)** batch is a multi-threaded batch. You can specify either of the following parameters while executing this batch:

Parameter Name	Description	Mandatory (Yes or No)
Transaction Header ID	Used when you want to validate a particular transaction feed.	No

Parameter Name	Description	Mandatory (Yes or No)
Transaction Source	Used when you want to validate the transaction feeds which are received from a particular transaction source.	No
Checksum Validation Required	Used to indicate whether the following should be validated: <ul style="list-style-type: none"> <li>The number of transaction records in the file matches the total transaction records in the header.</li> <li>The sum of transaction amount matches the total transaction amount in the header.</li> <li>The sum of transaction volume matches the total transaction volume in the header.</li> </ul> The valid values are: <ul style="list-style-type: none"> <li>Y</li> <li>N</li> </ul>	No
Duplicate Check Required	Used to indicate whether the following should be validated: <ul style="list-style-type: none"> <li>File with the same header date and external header ID is not available in the system.</li> </ul> The valid values are: <ul style="list-style-type: none"> <li>Y</li> <li>N</li> </ul> <div style="border: 1px solid black; padding: 2px; margin-top: 5px;"><b>Note:</b> The duplicate check is done only against the transaction feeds which are in the <b>Validated (VALD)</b> status and not against the transaction feeds which are in the <b>Uploaded (UPLD)</b> status.</div>	No
Allow Positive Transaction Volume in Header	Used to indicate whether you want to allow positive value in the total transaction volume which is specified in the header record. The valid values are: <ul style="list-style-type: none"> <li>Y</li> <li>N</li> </ul> <div style="border: 1px solid black; padding: 2px; margin-top: 5px;"><b>Note:</b> By default, the parameter value is set to <b>Y</b>.</div>	Yes
Allow Negative Transaction Volume in Header	Used to indicate whether you want to allow negative value in the total transaction volume which is specified in the header record. The valid values are: <ul style="list-style-type: none"> <li>Y</li> <li>N</li> </ul> <div style="border: 1px solid black; padding: 2px; margin-top: 5px;"><b>Note:</b> By default, the parameter value is set to <b>N</b>.</div>	Yes

Parameter Name	Description	Mandatory (Yes or No)
Allow Zero Transaction Volume in Header	Used to indicate whether you want to allow zero value in the total transaction volume which is specified in the header record. The valid values are: <ul style="list-style-type: none"> <li>• Y</li> <li>• N</li> </ul> <div style="border: 1px solid black; padding: 2px; margin-top: 5px;"><b>Note:</b> By default, the parameter value is set to N.</div>	Yes
Thread Pool Name	Used to specify the thread pool on which you want to execute the batch.	No

## Transaction Validation and Initial Price Item Determination

This process includes the following two sub-processes:

- **Transaction Validation** - In this sub-process, the transaction records are validated. The transaction level validations are done to check the integrity of the data. During the transaction validation, the system checks whether:
  - Transaction source is defined in the system.
  - Transaction record type is defined for the transaction source in the system.
  - Division and currencies are defined in the system.
  - The account with the specified account identifier, account identifier type and division exists in the system.

**Note:** This validation is done only when the **Transaction Detail Account Validation** option type of the **Feed Management (C1\_FM)** feature configuration is set to **Y**. If you set the **Transaction Detail Account Validation** option type of the **Feed Management (C1\_FM)** feature configuration to **N**, the system overrides the transaction's account identifier type, account identifier, and division with the first derived account's account identifier type, account identifier, and division, respectively.

- User ID (if available in the transaction information) is defined in the system.
- The value other than 'Y' or 'N' is not specified in the **Manual Switch** column.
- The value other than '+' or '-' is not specified in the **Credit/Debit Indicator** column.
- Transaction Amount is specified when Transaction Currency is specified, and vice versa.
- Additional Amount 1 is specified when Amount 1 Currency Code is specified, and vice versa.
- Additional Amount 2 is specified when Amount 2 Currency Code is specified, and vice versa.
- Additional Amount 3 is specified when Amount 3 Currency Code is specified, and vice versa.
- Additional Amount 4 is specified when Amount 4 Currency Code is specified, and vice versa.
- Additional Amount 5 is specified when Amount 5 Currency Code is specified, and vice versa.
- Additional Amount 6 is specified when Amount 6 Currency Code is specified, and vice versa.
- Additional Amount 7 is specified when Amount 7 Currency Code is specified, and vice versa.
- Additional Amount 8 is specified when Amount 8 Currency Code is specified, and vice versa.
- Additional Amount 9 is specified when Amount 9 Currency Code is specified, and vice versa.
- Additional Amount 10 is specified when Amount 10 Currency Code is specified, and vice versa.

If the transaction information is invalid or incorrect (for example, division is invalid), the status of the transaction is changed to **Error (EROR)**. But, if the transaction information is not available, the status of the transaction is changed to **Invalid (INVL)**.

- **Pricing Rule Type or Rule Type Determination** - If the transaction validation is successful, the system checks whether a primary pricing rule type is specified in the respective transaction record type. If a primary pricing rule type is specified in the transaction record type, the system calls the primary pricing rule type and invokes the algorithms which are attached to the following system events of the primary pricing rule type in the specified sequence:
  1. **Transaction Validation** - At present, the product has not shipped an algorithm type for the **Transaction Validation** system event. If required, you can create a custom algorithm type which validates the transaction before deriving the transaction legs.
  2. **Bill Group Derivation** - For more information, refer to the [Bill Group Derivation](#) on page 2733 section.
  3. **Account and Price Item Derivation** - Depending on the category to which the pricing rule type belongs, you need to attach different algorithm to the **Account and Price Item Derivation** system event. The following table lists the algorithms that you can attach to a primary pricing rule types with different category:

Pricing Rule Type Category	Algorithm	For more information on how the system derives the transaction legs, refer to...
Claim	C1_ACCPRIDRV	<a href="#">Account and Price Item Derivation (for the Claim Pricing Rule Type Category)</a> on page 2736
Retention Type Enrollment Based	C1_ACCPRIDRV	<a href="#">Account and Price Item Derivation (for the Retention Type Enrollment Based Pricing Rule Type Category)</a> on page 2766
Ancillary	C1_ACCPRIDRV	<a href="#">Account and Price Item Derivation (for the Ancillary Pricing Rule Type Category)</a> on page 2776

Once the primary pricing rule type is called, the system calls the eligible related pricing rule types (if any) defined in the primary pricing rule type. Note that the related pricing rule types are called one by one in the specified sequence. The system invokes the algorithms which are attached to the following system events of the related pricing rule type in the specified sequence:

1. **Transaction Validation** - At present, the product has not shipped an algorithm type for the **Transaction Validation** system event. If required, you can create a custom algorithm type which validates the transaction before deriving the transaction legs.
2. **Account and Price Item Derivation** - Depending on the category to which the pricing rule type belongs, you need to attach different algorithm to the **Account and Price Item Derivation** system event. The following table lists the algorithms that you can attach to a related pricing rule type with different category:

Pricing Rule Type Category	Algorithm	For more information on how the system derives the transaction legs, refer to...
Specific Stop-Loss	C1_ACCPRISL	<a href="#">Account and Price Item Derivation (for the Specific Stop-Loss and Aggregate Stop-Loss Pricing Rule Type Categories)</a> on page 2741
Aggregate Stop-Loss	C1_ACCPRISL	<a href="#">Account and Price Item Derivation (for the Specific Stop-Loss and Aggregate Stop-Loss Pricing Rule Type Categories)</a> on page 2741

Pricing Rule Type Category	Algorithm	For more information on how the system derives the transaction legs, refer to...
Retention Type Claim Based	C1_ACCPRIDRV	<i>Account and Price Item Derivation (for the Retention Type Claim Based Pricing Rule Type Category) on page 2754</i>

However, if a primary pricing rule type is not specified in the transaction record type, the system determines the account which will bear the charges for the transaction and the price item and variance parameter or price item parameters to which the transaction will be mapped using rules which are invoked through the rule type. Depending on the transaction record type, a rule type is invoked for each transaction. The effective rules with the specified rule type are executed, starting with the rule having highest priority, until a rule is satisfied. For example, a rule with the priority 10 will be executed before a rule with the priority 20.

**Note:** The system determines rules which are effective based on the **TFM - Processing Date** characteristic defined for the division to which the transaction belongs. The system uses the **TFM - Processing Date** characteristic which is effective on the transaction date. If the **TFM - Processing Date** characteristic type is set to **BATCH\_DT**, the system executes rules which are effective on the batch business date. However, if the **TFM - Processing Date** characteristic type is set to **TXN\_DT**, the system executes rules which are effective on the transaction date. Note that the transaction date must be earlier than or equal to the batch business date. And, if the **TFM - Processing Date** characteristic is not defined for the division to which a transaction belongs, the system, by default, executes rules which are effective on the transaction date.

Each rule contains one or more conditions or criteria. For example, Rule A states that if the transaction record type is R001 and the division is New York, then set the following output parameters:

- ACCT\_NO1\_Val - Account 1
- DIVISION1\_VAL - D1
- PRODUCT1\_1\_Val - Price Item X

Here, Transaction Record Type = R001 and Division = New York are two conditions. If these two conditions in the rule are satisfied, then set three output parameters - ACCT\_NO1\_Val, DIVISION1\_VAL and PRODUCT1\_1\_Val. Now, when this rule is executed and the transaction satisfies this criteria, the transaction is mapped to Price Item X and Account 1 which belongs to D1 bears the charges for the transaction. In case, the rule has four output parameters (ACCT\_NO1\_Val set to Account 1, DIVISION1\_VAL set to D1, PRODUCT1\_1\_Val set to Price Item X, and PRODUCT1\_2\_Val set to Price Item Y), the transaction will be mapped to both the price items (i.e. Price Item X and Price Item Y) and Account 1 which belongs to D1 bears the charges for the transaction. A transaction can be mapped to one or more price items or to one or more price item and TOU (variance parameter) combinations. If the multi parameter based pricing feature is enabled, you can map a transaction to one or more price item and price item parameters combinations. Let us understand this with the help of an example.

Rule B states that if the transaction is performed in US and the transaction amount exceeds 1000 USD, then set the following output parameters:

- ACCT\_NO1\_Val - Account A
- DIVISION1\_VAL - D1
- PRODUCT1\_1\_Val - Price Item X
- PCD1\_1\_1\_VAL - Country
- PVL1\_1\_1\_VAL - US
- PCD1\_1\_2\_VAL - Currency
- PVL1\_1\_2\_VAL - USD
- PRODUCT1\_2\_Val - Price Item Y
- PCD1\_2\_1\_VAL - Country

- PVL1\_2\_1\_VAL - US
- PCD1\_2\_2\_VAL - Currency
- PVL1\_2\_2\_VAL - USD

Now, when this rule is executed and the transaction satisfies the criteria, Account A which belongs to D1 bears the charges for the transaction which is mapped to the following price item and price item parameters combinations:

- Price Item X, Country - US, Currency - USD
- Price Item Y, Country - US, Currency - USD

More than one account can bear the charges for a transaction and each account can belong to a different division. You can map a transaction to one or more price items, to one or more price item and TOU (variance parameter) combinations, or to one or more price item and price item parameters combinations. The system allows you to map price items for each account. For example, Rule C states that if the transaction is performed in UK and the transaction amount exceeds 1000 USD, then set the following output parameters:

- ACCT\_NO1\_Val - Account A
- DIVISION1\_VAL - D1
- PRODUCT1\_1\_Val - Price Item X
- PCD1\_1\_1\_VAL - Country
- PVL1\_1\_1\_VAL - UK
- PCD1\_1\_2\_VAL - Currency
- PVL1\_1\_2\_VAL - USD
- PRODUCT1\_2\_Val - Price Item Y
- PCD1\_2\_1\_VAL - Country
- PVL1\_2\_1\_VAL - UK
- PCD1\_2\_2\_VAL - Currency
- PVL1\_2\_2\_VAL - USD
- ACCT\_NO2\_Val - Account B
- DIVISION2\_VAL - D2
- PRODUCT2\_1\_Val - Price Item A
- PCD2\_1\_1\_VAL - Country
- PVL2\_1\_1\_VAL - US
- PCD2\_1\_2\_VAL - Currency
- PVL2\_1\_2\_VAL - USD

Now, when this rule is executed and the transaction satisfies the criteria, the transaction is mapped to the following price item and price item parameters combinations:

<b>Charges Borne By</b>	<b>Division to which the account belongs...</b>	<b>Price Item</b>	<b>Country</b>	<b>Currency</b>
Account A	D1	Price Item X	UK	USD
Account A	D1	Price Item Y	UK	USD
Account B	D2	Price Item A	US	USD

You can limit the maximum accounts that can bear the charges for a transaction, maximum price item that can be mapped to a transaction, and maximum parameters that can be used with each price item to determine price item pricing. For more information, see [Defining a Transaction Record Type](#) on page 1000. You can also define rules to ignore transactions based on the transaction attributes. If the rule returns the **IGNORE\_SW** equal to **Y**, the status of the transaction is changed to **Ignored (IGNR)** and no further processing takes place on the transaction.

You can use the following output parameters while defining rules in the system:

Output Parameter	Naming Convention	Example	Description
Account Identifier	ACCT_NOX_Val	ACCT_NO1_Val, ACCT_NO2_Val, ACCT_NO3_Val, ....	Used to indicate the account which must bear the charges for the transaction.
Account Identifier Column Name	ACCT_NOX_Col	ACCT_NO1_Col, ACCT_NO2_Col, ACCT_NO3_Col, ...	Used to indicate the column from where the account identifier corresponding to the transaction (in the transaction details) must be picked.
Account Identifier Type	ACCT_NO_TYPEX_Val	ACCT_NO_TYPE1_Val, ACCT_NO_TYPE2_Val, ACCT_NO_TYPE3_Val, ...	Used to indicate the type of account identifier.
Account Identifier Type Column Name	ACCT_NO_TYPEX_Col	ACCT_NO_TYPE1_Col, ACCT_NO_TYPE2_Col, ACCT_NO_TYPE3_Col, ...	Used to indicate the column from where the account identifier type corresponding to the transaction (in the transaction details) must be picked.
Account Division	DIVISIONX_VAL	DIVISION1_VAL	Used to indicate the division to which the account belongs.
Account Division Column Name	DIVISIONX_COL	DIVISION1_COL	Used to indicate the column from where the division corresponding to the transaction (in the transaction details) must be picked.
Price Item Name	PRODUCTX_Y_Val <b>Note:</b> Here, X represents the account and Y represents the price item.	PRODUCT1_1_Val, PRODUCT2_1_Val, PRODUCT2_2_Val, ....	Used to indicate the price item to which the transaction must be mapped.
Price Item Column Name	PRODUCTX_Y_Col <b>Note:</b> Here, X represents the account and Y represents the price item.	PRODUCT1_1_Col,, PRODUCT2_1_Col, PRODUCT2_2_Col, ...	Used to indicate the column from where the price item corresponding to the transaction (in the transaction details) must be picked.

Output Parameter	Naming Convention	Example	Description
TOU	TOUX_Y_Val  <b>Note:</b> Here, X represents the account and Y represents the price item.	TOU1_1_Val, TOU2_1_Val, TOU2_2_Val, ...	Used to indicate the variance parameter which you want to use along with the price item for price determination.  <b>Note:</b> This output parameter appears only when the <b>Multi Price Parameter</b> option type of the <b>Multi Parameter Based Pricing (C1_PPARM_FLG)</b> feature configuration is set to <b>False</b> .
TOU Column Name	TOUX_Y_Col  <b>Note:</b> Here, X represents the account and Y represents the price item.	TOU1_1_Col, TOU2_1_Col, TOU2_2_Col, ...	Used to indicate the column from where the variance parameter corresponding to the transaction (in the transaction details) must be picked.  <b>Note:</b> This output parameter appears only when the <b>Multi Price Parameter</b> option type of the <b>Multi Parameter Based Pricing (C1_PPARM_FLG)</b> feature configuration is set to <b>False</b> .
Parameter Code	PCDX_Y_Z_VAL  <b>Note:</b> Here, X represents the account, Y represents the price item, and Z represents the parameter.	PCD1_1_1_VAL, PCD1_2_1_VAL, PCD2_1_1_VAL, ...	Used to indicate the parameter which you want to use along with the price item for price determination.  <b>Note:</b> This output parameter appears only when the <b>Multi Price Parameter</b> option type of the <b>Multi Parameter Based Pricing (C1_PPARM_FLG)</b> feature configuration is set to <b>True</b> .  You must not specify any special character except underscore ( ) in the parameter code. Otherwise, the status of the transaction is changed to <b>Error (EROR)</b> .



Output Parameter	Naming Convention	Example	Description
Parameter Value	PVLX_Y_Z_VAL  <b>Note:</b> Here, X represents the account, Y represents the price item, and Z represents the parameter.	PVL1_1_1_VAL, PVL1_2_1_VAL, PVL2_1_1_VAL, ...	Used to specify the value for the parameter.  <b>Note:</b> This output parameter appears only when the <b>Multi Price Parameter Based Pricing (C1_PPARAM_FLG)</b> feature configuration is set to <b>True</b> .  The parameter value must not contain the equal to (=) and tilde (~) symbols. Otherwise, the status of the transaction is changed to <b>Error (EROR)</b> .
Parameter Value Column Name	PVLX_Y_Z_COL  <b>Note:</b> Here, X represents the account, Y represents the price item, and Z represents the parameter.	PVL1_1_1_COL, PVL1_2_1_COL, PVL2_1_1_COL, ...	Used to indicate the column from where the parameter value corresponding to the transaction (in the transaction details) must be picked.  <b>Note:</b> This output parameter appears only when the <b>Multi Price Parameter Based Pricing (C1_PPARAM_FLG)</b> feature configuration is set to <b>True</b> .  The column from where the parameter value is picked must not contain the equal to (=) and tilde (~) symbols. Otherwise, the status of the transaction is changed to <b>Error (EROR)</b> .

Output Parameter	Naming Convention	Example	Description
Processing Date Type	PRCS_DTX_Y_TYP  <div style="border: 1px solid black; padding: 5px;"> <p><b>Note:</b> Here, X represents the account and Y represents the price item.</p> </div>	PRCS_DT1_1_TYP, PRCS_DT1_2_TYP, PRCS_DT2_1_TYP, ...	Used to indicate the date type using which you want to determine the effective price item parameters, pricing, and exchange rate. The valid values are: <ul style="list-style-type: none"> <li>• <b>TXN_DT</b> - Used when you want to determine price item parameters, pricing, and exchange rate which are effective on the transaction date.</li> <li>• <b>Batch_DT</b> - Used when you want to determine price item parameters, pricing, and exchange rate which are effective on the batch business date.</li> </ul> <div style="border: 1px solid black; padding: 5px;"> <p><b>Note:</b> Based on the <b>TFM - Processing Date</b> characteristic defined for the division to which a transaction belongs, the system determines the rules, price item parameters, pricing, and exchange rate which are effective on the transaction or batch business date. The price item parameters, pricing, and exchange rate which are effective is determined for all account and price item combinations to which the transaction is mapped. If you want to use a custom processing date for a particular account and price item combination to which the transaction is mapped, you need to set the PRCS_DTX_Y_TYP output parameter. In other words, the PRCS_DTX_Y_TYP output parameter helps you to override the processing date for a particular account and price item combination. However, the overridden processing date is used only while determining effective price item parameters, pricing, and exchange rate.</p> </div>

Output Parameter	Naming Convention	Example	Description
Processing Date	PRCS_DTX_Y_VAL  <b>Note:</b> Here, X represents the account and Y represents the price item.	PRCS_DT1_1_VAL, PRCS_DT1_2_VAL, PRCS_DT2_1_VAL, ...	Used to specify a custom date on which you want to determine the effective price item parameters, pricing, and exchange rate.  <b>Note:</b> The custom date must be a date other than the transaction or batch business date.  Based on the <b>TFM - Processing Date</b> characteristic defined for the division to which a transaction belongs, the system determines the rules, price item parameters, pricing, and exchange rate which are effective on the transaction or batch business date. The price item parameters, pricing, and exchange rate which are effective is determined for all account and price item combinations to which the transaction is mapped. If you want to use a custom processing date for a particular account and price item combination to which the transaction is mapped, you need to set the PRCS_DTX_Y_VAL output parameter. In other words, the PRCS_DTX_Y_VAL output parameter helps you to override the processing date for a particular account and price item combination. However, the overridden processing date is used only while determining effective price item parameters, pricing, and exchange rate.
Ignore Transaction	IGNORE_SW		Used to ignore transactions based on the transaction attributes. The valid values are: <ul style="list-style-type: none"> <li>• Y</li> <li>• N</li> </ul>

Once the transaction satisfies any rule (invoked through the rule type), one transaction leg is created for each account, division, price item, and variance parameter or price item parameters combination. Let us understand this with the help of an example. The following table lists the accounts and price items to which T1, T2, and T3 are mapped:

Transaction	Charges Borne By	Division to which the account belongs...	Price Item	Variance Parameter	Price Item Parameters
T1	A1	D1	P1	-	Country - US, Currency - USD
T1	A1	D1	P2	-	Country - Germany, Currency - USD
T1	A2	D2	P3	USD	-
T2	A1	D1	P1	-	Country - US, Currency - USD
T2	A2	D2	P2	USD	-
T3	A1	D1	P3	-	Country - Germany, Currency - USD

In such case, the system will create three legs for T1, two legs for T2, and one leg for T3. Each transaction leg will have its own status. The status of the transaction legs and transaction is changed to **Initial Price Item Determined (INPD)**. However, if a transaction does not satisfy any rule, the status of the transaction is changed to **Error (EROR)**.

Note:
<p>During this sub-process, the system validates the following:</p> <ul style="list-style-type: none"> <li>• Whether the price item parameters specified in the output parameters are effective for the price item on the processing date.</li> <li>• Whether the mandatory price item parameter which is effective on the processing date is specified in the output parameter.</li> <li>• Whether the parameter value is specified for all mandatory price item parameters which are effective on the processing date.</li> </ul> <p>If any of the above validation fails, the status of the transaction is changed to <b>Error (EROR)</b> and no transaction legs are created.</p>

Once the transaction legs are created, the price item parameters of each transaction leg are grouped. For example, when a transaction is mapped to the following price item and price item parameters combinations, the system creates three groups - Group A, Group B, and Group C:

- Account A, Price Item X, Country - US, Currency - USD
- Account A, Price Item Y, Country - Germany, Currency - USD
- Account B, Price Item X, Country - England, Currency - USD

Group A contains Country - US, Currency - USD; Group B contains Country - Germany, Currency - USD; and Group C contains Country - England, Currency - USD.

A set of price item parameters are grouped only when the multi parameter based pricing feature is enabled. A group is used to determine the price item pricing. A unique group ID is generated for each group. If a group with a set of price item parameters already exists in the system, a new group is not created. Instead, the existing group is used for determining the price item pricing.

You can execute this process through a multi-threaded batch named **Validate Transaction and Derive Price Item (C1-TXNIP)**. You can specify the following parameters while executing this batch:

Parameter Name	Description	Mandatory (Yes or No)
Batch Business Date	<p>Used to identify the transactions for which you want to perform validation and determine price item. The system considers the transactions whose transaction date is earlier than or equal to the batch business date.</p> <div style="border: 1px solid black; padding: 5px;"> <p><b>Note:</b></p> <p>If you do not specify any date, the batch business date is set to the current date.</p> <p>The batch business date used while executing the <b>C1-TXNIP</b> batch is stamped in the database. It is then used while executing all other consequent batches in the transaction aggregation cycle.</p> </div>	No
Transaction Header ID	Used when you want to validate and derive price item for the transactions which are received in a particular transaction feed.	No
Transaction Source	Used when you want to validate and derive price item for the transactions which are received from a particular transaction source.	No
Division	Used when you want to validate and derive price item for the transactions belonging to a particular division.	No
Shuffle Work Unit	<p>Used to indicate whether you want to shuffle the work units across threads to correct the uneven thread processing time. The valid values are:</p> <ul style="list-style-type: none"> <li>• Y</li> <li>• N</li> </ul> <div style="border: 1px solid black; padding: 5px;"> <p><b>Note:</b> By default, the parameter value is set to N.</p> </div>	No
Chunk Size	Used to specify the number of transactions you want to execute in each work unit.	Yes
Maximum Batch Count	Used to specify the maximum number of transactions after which the data must be transferred to the database.	Yes
Thread Pool Name	Used to specify the thread pool on which you want to execute the batch.	No

A log is generated if the **Logging Rules for Transaction Feed** option type in the **Rule Engine (C1\_RLENG)** feature configuration is set to **True**. This log indicates the rules that were executed for each transaction and whether each rule passed or failed during the execution.

**Note:**

You can aggregate transaction legs in a billable charge using aggregation parameters other than account ID, price item code, variance or price item parameters, aggregation start date, and aggregation end date. The additional aggregation parameters can be stamped in the form of aggregation parameter group ID while performing post-processing activities for each transaction leg. This aggregation parameter group ID will be used in subsequent batches during the transaction aggregation cycle. If you want to perform some post-processing activities on the transaction legs, you need to attach a post-processing algorithm on the **TFM - Price Item Derivation Post-Processing** algorithm entity in the **Algorithms** tab of the **Division** screen. Note that the system invokes the algorithm which is attached on the division to which the transaction belongs. This algorithm is triggered only for transactions which are in the **Initial Price Item Determined (INPD)** status. It is triggered before the price item parameter group is created.

A sample post-processing algorithm type named **C1\_PRDR\_POPC** is shipped with the price item. It does not have any business logic. If you want to undertake some post-processing activities for a transaction leg, you need to create custom algorithm type and attach the respective algorithm on the **TFM - Price Item Derivation Post-Processing** algorithm spot of the respective division. You can refer to the **C1\_PRDR\_POPC** algorithm type to understand the input parameters that must be passed to the custom algorithm type.

Once the **Validate Transaction and Derive Price Item (C1-TXNIP)** batch is executed, the processing date is stamped against each transaction leg in the database. If a custom processing date is specified for a particular account and price item combination, the custom processing date is stamped against the respective transaction leg. Otherwise, the processing date defined for the division to which a transaction belongs is stamped against the legs of the respective transaction. The processing date which is stamped against a transaction leg in the database is used while executing all subsequent batches in the transaction aggregation cycle.

**Related Topics**

For more information on...	See...
Rules Engine	<a href="#">Rules Engine</a> on page 761
How to define a rule	<a href="#">Defining a Rule</a> on page 781

**Price Item Pricing Verification**

In this process, the system behaves in the following manner:

If the Multi Parameter Based Pricing feature is...	Then...
Disabled	<p>The system checks whether effective pricing is available for the account, price item or regular bundle (to which the price item belongs) or parent (regular) bundle (to which the regular bundle belongs) and/or TOU combination on the processing date. The system searches for the price item, regular bundle or parent bundle pricing depending on the value defined for the <b>Prefer Price Item Over Bundle</b> parameter in the price assignment search algorithm (which is defined for the division to which the account belongs).</p> <p>If the price item belongs to a regular bundle and the effective pricing is available for the regular bundle at the account level, the system considers the regular bundle as the final price item and maps it to the transaction leg. If the effective pricing is not available for the regular bundle, the system checks whether the effective pricing is available for the parent bundle (if assigned) at the account level. If the effective pricing is available for the parent bundle, the system considers the parent bundle as the final price item and maps it to the transaction leg. If the effective pricing is not available for the price item, regular bundle, or parent bundle, the status of the transaction leg is changed to <b>Error (EROR)</b>. If the effective pricing is not available for one or more price items to which a transaction is mapped, the status of the transaction is also changed to <b>Error (EROR)</b>.</p>
Enabled	<p>The system checks whether effective pricing is available for the account, price item or regular bundle (to which the price item belongs) or parent (regular) bundle (to which the regular bundle belongs) and/or price item parameters (parameter group) combination on the processing date. The system searches for the price item, regular bundle or parent bundle pricing depending on the value defined for the <b>Prefer Price Item Over Bundle</b> parameter in the price assignment search algorithm (which is defined for the division to which the account belongs).</p> <p>The system searches for a price with exact match at all levels defined in the search order. If the exact match is available at two or more levels, the price assignment at the higher precedence level is considered for calculating the charges. But, if the system does not find the exact match at any level, it searches for the best fit match at all levels. For more information about best fit match, see <a href="#">Multi Parameter Based Pricing</a> on page 273. If the system finds the best fit match with same weight at multiple levels, the price assignment at the higher precedence level is considered for calculating the charges.</p> <p>If the price item belongs to a regular bundle and the exact or best fit price is available for the regular bundle at the account level, the system considers the regular bundle as the final price item and maps it to the transaction leg. If the exact or best fit price is not available for the regular bundle, the system checks whether the exact or best fit price is available for the parent bundle (if assigned) at the account level. If the exact or best fit price is available for the parent bundle, the system considers the parent bundle as the final price item and maps it to the transaction leg. If the exact or best fit price is not available for the price item, regular bundle, or parent bundle, the status of the transaction leg is changed to <b>Error (EROR)</b>. If the exact or best fit price is not available for one or more price items to which a transaction is mapped, the status of the transaction is also changed to <b>Error (EROR)</b>.</p>

**Note:**

The processing date which is stamped against a transaction leg is used to determine effective pricing for the transaction leg.

The order in which the system searches effective pricing for the price item, regular bundle, or parent (regular) bundle at the same level depends on the value defined for the **Prefer Price Item Over Bundle** parameter in the price assignment search algorithm. If the value of the **Prefer Price Item Over Bundle** parameter is set to **Y**, the system first searches whether effective pricing is available for the price item. If the effective pricing is not available for the price item, then the system searches whether effective pricing is available for the regular bundle at the same level. If the effective pricing is not available for the regular bundle, then the system searches whether effective pricing is available for the parent bundle at the same level. However, if the value of the **Prefer Price Item Over Bundle** parameter is set to **N**, the system first searches whether effective pricing is available for the parent bundle. If the effective pricing is not available for the parent bundle, then the system searches whether effective pricing is available for the regular bundle at the same level. If the effective pricing is not available for the regular bundle, then the system searches whether effective pricing is available for the price item at the same level.

In addition, the status of the transaction and transaction leg is changed to **Error (EROR)** when:

- There is no contract available with the specified contract type on the transaction date or when the contract is inactive.
- There are multiple effective contracts of the same contract type (available on the transaction date) in **Active**, **Pending Stop**, or **Stop** status.
- The **Price Assignment Search** algorithm is not defined for the division.
- The parameter values are either not defined or invalid in the **Price Assignment Search** algorithm on the processing date.
- The period in which the transaction date falls is not defined in the aggregation schedule.

Once the effective pricing is determined for the initial or final price item, the values of the following pricing attributes are retrieved:

- Ignore Transaction
- Aggregate Transaction
- Aggregation Schedule
- Rating Criteria
- Price Assignment ID
- Account ID (in case of account agreed and price list pricing)
- Person ID (in case of customer agreed and price list pricing)
- Price List ID (in case of price list pricing)
- Contract ID
- Regular Bundle Code
- Pricing Currency

In addition, the system invokes the algorithms attached to the following algorithm spots of the derived account's division in the specified sequence for the self-funded health care business:

1. **TFM - Contract Derivation** - You can attach an algorithm created using the **SA\_DERV\_POPC** algorithm type to this algorithm spot. If the account has multiple active contracts of the contract type which is associated with the price item, this algorithm derives the contract which is associated with the policy and maps it to the transaction leg. The manner in which the system derives the active contract for the account differs in the following scenarios:



<b>If the effective pricing rule stamped against the transaction leg is defined at ...</b>	<b>Then...</b>
The bill group level	The system first fetches the policy derived for the transaction and then derives the active contract which is associated with the policy.
The parent customer level	The system first fetches the bill group to which the account belongs and then the policy where the bill group is associated with the policy using the policy person role which is specified in the <b>Bill Group Policy Person Role</b> option type of the <b>C1-ASOBLLNG</b> feature configuration. Once the policy is derived, the system derives the active contract which is associated with the policy.

2. **TFM - Verify Pricing Post-Processing** - You can attach an algorithm created using the **C1-VRPR\_POPC** algorithm type to this algorithm spot. This algorithm removes the price assignment ID and price item parameter group ID from the summary ID column of each transaction leg.

You can execute this process through a multi-threaded batch named **Price Item Pricing Verification (C1-TXNVP)**. You can specify either of the following parameters while executing this batch:

<b>Parameter Name</b>	<b>Description</b>	<b>Mandatory (Yes or No)</b>
Transaction Header ID	Used when you want to find the price item pricing for transactions which are received in a particular transaction feed.	No
Transaction Source	Used when you want to find the price item pricing for transactions which are received from a particular transaction source.	No
Division	Used when you want to find the price item pricing for transactions belonging to a particular division.	No
Chunk Size	Used to specify the number of transactions you want to execute in each work unit.	Yes
Thread Pool Name	Used to specify the thread pool on which you want to execute the batch.	No

Note that the **Price Item Pricing Verification (C1-TXNVP)** batch does not change the status of the transaction and its legs. You need to execute the **Update Status (C1-TXNEX)** batch to update the status of the transaction and its legs. Besides updating the status, the **Update Status (C1-TXNEX)** batch determines the rate for transaction legs whose effective pricing has either of the following set of attributes:

- **Ignore Transaction** is set to **Yes** and **Rating Criteria** is set to **Rate Transactions (RITX)**
- **Ignore Transaction** is set to **No**, **Aggregate Transaction** is set to **Yes**, and **Rating Criteria** is set to **Rate individual transactions and aggregate calc lines across transactions (RITA)**

Each set of pricing attributes indicates how the transaction legs must be rated before billing. For more information about the different ways in which a transaction leg can be rated, see [Transaction Rating Before Billing](#) on page 848.

You can specify either of the following parameters while executing this batch:

<b>Parameter Name</b>	<b>Description</b>	<b>Mandatory (Yes or No)</b>
Transaction Header ID	Used when you want to change the status of transactions which are received in a particular transaction feed.	No

Parameter Name	Description	Mandatory (Yes or No)
Transaction Source	Used when you want to change the status of transactions which are received from a particular transaction source.	No
Division	Used when you want to change the status of transactions belonging to a particular division.	No
Shuffle Work Unit	Used to indicate whether you want to shuffle the work units across threads to correct the uneven thread processing time. The valid values are: <ul style="list-style-type: none"> <li>• Y</li> <li>• N</li> </ul> <div style="border: 1px solid black; padding: 2px; margin-top: 5px;"><b>Note:</b> By default, the parameter value is set to N.</div>	No
Chunk Size	Used to specify the number of transactions you want to execute in each work unit.	Yes
Maximum Batch Count	Used to specify the maximum number of transactions after which the data must be transferred to the database.	Yes
Thread Pool Name	Used to specify the thread pool on which you want to execute the batch.	No

**Note:**

You must specify same parameters in the **Product Pricing Verification (C1-TXNVP)** and **Update Status (C1-TXNEX)** batches. Otherwise, erroneous results might occur.

If you want to do some preprocessing activities before invoking the rates engine, you need to attach a preprocessing algorithm on the **TFM - Rate Pre-Processing** algorithm entity in the **Algorithms** tab of the **Division** screen. Note that the system invokes the algorithm which is attached on the derived account's division and not on the division to which the transaction belongs. A sample preprocessing algorithm type named **C1\_RTCL\_PRPC** is shipped with the product. It does not have any business logic. If you want to undertake some preprocessing activities before invoking the rates engine, you need to create custom algorithm type and attach the respective algorithm on the **TFM - Rate Pre-Processing** algorithm spot of the respective division. You can refer to the **C1\_RTCL\_PRPC** algorithm type to understand the input parameters that must be passed to the custom algorithm type.

If a transaction leg is ignored and not considered for billing, the status of the transaction leg is changed to **Ignored (IGNR)**, whereas the status of the transaction remains as **Initial Price Item Determined (INPD)**. However, if all legs of a transaction are ignored and not considered for billing, the status of the transaction and transaction legs is changed to **Ignored (IGNR)**.

You can store the price item pricing information, and thereby improve the **Price Item Pricing Verification (C1-TXNVP)** batch performance. If you set the **Use Materialized Views** option type of the **C1\_FM** feature configuration to **true**, the system will store the product pricing information in the following tables:

- CI\_PRC\_AGRD
- CI\_PRC\_PL
- CI\_PRC\_INH\_PL

But, if you set the **Use Materialized Views** option type of the **C1\_FM** feature configuration to **false**, the system will not store the product pricing information in the above mentioned tables. If there are any pricing changes, you will have to update these tables before executing the **Price Item Pricing Verification (C1-TXNVP)** batch. You can update the product pricing information in these tables by executing the **Refresh Pricing (C1-TXNRP)** batch. Ideally, you must execute the **Refresh Pricing (C1-TXNRP)** batch after you execute the **Flush All Caches (F1-FLUSH)** batch in the

transaction aggregation cycle. You can specify the following parameters while executing the **Refresh Pricing (C1-TXNRP)** batch:

Parameter Name	Description	Mandatory (Yes or No)
Division	Used when you want to update the price item pricing information of accounts belonging to a particular division.	No
Chunk Size	Used to specify the number of persons whose regular and post-processing price item pricing information you want to update in each work unit.	Yes
Thread Pool Name	Used to specify the thread pool on which you want to execute the batch.	No

### Related Topics

For more information on...	See...
Transaction Leg Status Transition	<a href="#">Transaction Leg Status Transition</a> on page 903
How to set the C1_FM feature configuration	<a href="#">Setting the C1_FM Feature Configuration</a> on page 2910

## Aggregation

Once the price item pricing verification is complete, you can aggregate the transaction legs, create a billable charge, and update the SQI values in the billable charge. In the aggregation process, the system behaves in the following manner:

If the Multi Parameter Based Pricing feature is...	Then...
Disabled	<p>The system checks the value defined in the <b>Aggregate Transaction</b> field. If the <b>Aggregate Transaction</b> field is set to <b>No</b>, the system creates one billable charge (with the <b>Billable</b> status) for each transaction leg. However, if the <b>Aggregate Transaction</b> field is set to <b>Yes</b>, the system creates one billable charge (with the <b>Billable</b> status) for all transactions legs having the same price item and TOU combination and whose transaction date falls between the aggregation schedule.</p> <div style="border: 1px solid black; padding: 5px;"> <p><b>Note:</b></p> <p>During the billable charge creation, the system also considers the contract start and end dates along with the aggregation schedule. If the contract start date falls between the aggregation schedule, the billable charge start date is equal to the contract start date. If the contract start date is earlier than the aggregation schedule start date, the billable charge start date is equal to the aggregation schedule start date. If the contract end date is earlier than the aggregation schedule end date, the billable charge end date is equal to the contract end date. If the contract end date is later than the aggregation schedule end date, the billable charge end date is equal to the aggregation schedule end date. However, if the contract start date is later than the aggregation schedule end date or if the contract end date is earlier than the aggregation schedule start date, the status of the transaction leg is changed to <b>Error (EROR)</b>.</p> <p>If the aggregated billable charge already exists for the account, price item and TOU combination and there is no bill segment associated with the billable charge, the system will update the SQI values in the existing billable charge.</p> </div>

If the Multi Parameter Based Pricing feature is...	Then...
Enabled	<p>The system checks the value defined in the <b>Aggregate Transaction</b> field. If the <b>Aggregate Transaction</b> field is set to <b>No</b>, the system creates one billable charge (with the <b>Billable</b> status) for each transaction leg. However, if the <b>Aggregate Transaction</b> field is set to <b>Yes</b>, the system creates one billable charge (with the <b>Billable</b> status) for all transaction legs having the same price item and price item parameters (parameter group) combination and whose transaction date falls between the aggregation schedule.</p> <div style="border: 1px solid black; padding: 5px;"> <p><b>Note:</b></p> <p>During the billable charge creation, the system also considers the contract start and end dates along with the aggregation schedule. If the contract start date falls between the aggregation schedule, the billable charge start date is equal to the contract start date. If the contract start date is earlier than the aggregation schedule start date, the billable charge start date is equal to the aggregation schedule start date. If the contract end date is earlier than the aggregation schedule end date, the billable charge end date is equal to the contract end date. If the contract end date is later than the aggregation schedule end date, the billable charge end date is equal to the aggregation schedule end date. However, if the contract start date is later than the aggregation schedule end date or if the contract end date is earlier than the aggregation schedule start date, the status of the transaction leg is changed to <b>Error (EROR)</b>.</p> <p>If the aggregated billable charge already exists for the account, price item and price item parameters combination and there is no bill segment associated with the billable charge, the system will update the SQI values in the existing billable charge.</p> </div>

The transaction aggregation is done based on the aggregation schedule defined in the price item pricing. You can use the following standard schedules or you can create your own custom schedules for aggregation:

- Daily
- Weekly
- Monthly
- Quarterly
- Yearly

Once the billable charge is created, the system aggregates the SQIs defined for the price item — division combination using the aggregation function and then updates the billable charge with the respective SQI values. If the aggregation function is based on the transaction amount or on any other user defined amount and the transaction or user defined currency is different from the pricing currency, the system does currency conversion if the appropriate exchange rate is available in the system. The processing date which is stamped against a transaction leg is used to determine effective exchange rate for the transaction leg.

Once the SQI values are updated in the billable charge, the rate is determined for the transaction leg whose effective pricing has either of the following set of attributes:

- **Ignore Transaction** is set to **No**, **Aggregate Transaction** is set to **Yes**, and **Rating Criteria** is set to **Aggregate transactions and then rate aggregated SQs (AGTR)**
- **Ignore Transaction** is set to **No**, **Aggregate Transaction** is set to **No**, and **Rating Criteria** is set to **Rate Transactions (RITX)**

Each set of pricing attributes indicates how the transaction legs must be rated before billing. For more information about the different ways in which a transaction leg can be rated, see [Transaction Rating Before Billing](#) on page 848.

**Note:** If you want to do some preprocessing activities while determining rate, you need to attach a preprocessing algorithm on the **TFM - Rate Pre-Processing** algorithm entity in the **Algorithms** tab of the **Division** screen. Note that the system invokes the algorithm which is attached on the derived account's division and not on the division to which the transaction belongs. A sample preprocessing algorithm type named **C1\_RTCL\_PRPC** is shipped with the price item. It does not have any business logic. If you want to undertake some preprocessing activities while determining rate for transaction legs, you need to create custom algorithm type and attach the respective algorithm on the **TFM - Rate Pre-Processing** algorithm spot of the respective division. You can refer to the **C1\_RTCL\_PRPC** algorithm type to understand the input parameters that must be passed to the custom algorithm type.

In addition, the system invokes the algorithm attached to the following algorithm spot of the derived account's division for the **self-funded health care** business:

- **TFM - Billable Charge Post Processing** - You can attach an algorithm created using the **C1\_BCHG\_POPC** algorithm type to this algorithm spot. This algorithm invokes the algorithm which is attached to the **Bill After Date Determination** system event of the respective pricing rule type. For more information, refer to the [Bill After Date Determination](#) on page 2785 section.

Once the billable charge is created and updated successfully, the status of the transaction leg is changed to **Completed (COMP)**. However, if the SQIs are not defined for the price item — division combination, the transaction aggregation rule is not defined for the SQI, or if the exchange rate is not available during currency conversion, the status of the transaction leg is changed to **Error (EROR)**. If all legs of a transaction are in the **Completed (COMP)** status, the status of the transaction is changed to **Completed (COMP)**. But, if any of the transaction leg is in the **Error (EROR)** status, the status of the transaction is changed to **Error (EROR)**.

You can execute this process through a multi-threaded batch named **Service Quantity Calculation (C1-TXNSQ)**. You can specify either of the following parameters while executing this batch:

Parameter Name	Description	Mandatory (Yes or No)
Transaction Header ID	Used when you want to create the billable charges for transactions which are received in a particular transaction feed.	No
Transaction Source	Used when you want to create the billable charges for transactions which are received from a particular transaction source.	No
Division	Used when you want to create the billable charges for transactions belonging to a particular division.	No
Chunk Size	Used to specify the number of transactions you want to execute in each work unit.	Yes
Maximum Batch Count	Used to specify the maximum number of transactions after which the data must be transferred to the database.	Yes
Thread Pool Name	Used to specify the thread pool on which you want to execute the batch.	No

The **Service Quantity Calculation (C1-TXNSQ)** batch does not change the status of the transaction and its legs. You need to execute the **Mark Completion (C1-TXNCM)** batch to update the status of the transaction and its legs. Besides updating the status, the **Mark Completion (C1-TXNCM)** batch does the following with other legs when billable charge is not created for one or more transaction legs:

<b>Rate for other transaction leg is determined using the following set of pricing attributes...</b>	<b>Then....</b>
<b>Ignore Transaction</b> is set to <b>Yes</b> and <b>Rating Criteria</b> is set to <b>Rate Transactions (RITX)</b>	The corresponding calculation lines of the transaction leg are deleted.
<b>Ignore Transaction</b> is set to <b>No</b> , <b>Aggregate Transaction</b> is set to <b>No</b> , and <b>Rating Criteria</b> is set to <b>Rate Transactions (RITX)</b>	The corresponding billable charge and calculation lines of the transaction leg are deleted.
<b>Ignore Transaction</b> is set to <b>No</b> , <b>Aggregate Transaction</b> is set to <b>Yes</b> , and <b>Rating Criteria</b> is set to <b>Rate individual transactions and aggregate calc lines across transactions (RITA)</b>	The corresponding calculation lines of the transaction leg are deleted.
<b>Ignore Transaction</b> is set to <b>No</b> , <b>Aggregate Transaction</b> is set to <b>Yes</b> , and <b>Rating Criteria</b> is set to <b>Aggregate transactions and then rate aggregated SQs (AGTR)</b>	The corresponding billable charge and calculation lines are not deleted.
<b>Ignore Transaction</b> is set to <b>No</b> , <b>Aggregate Transaction</b> is set to <b>No</b> , and <b>Rating Criteria</b> is set to <b>Do Not Rate Transactions</b>	The corresponding non-aggregated billable charge is deleted.

You can specify either of the following parameters while executing the **Mark Completion (C1-TXNCM)** batch:

<b>Parameter Name</b>	<b>Description</b>	<b>Mandatory (Yes or No)</b>
Transaction Header ID	Used when you want to change the status of transactions which are received in a particular transaction feed.	No
Transaction Source	Used when you want to change the status of transactions which are received from a particular transaction source.	No
Division	Used when you want to change the status of transactions belonging to a particular division.	No
Chunk Size	Used to specify the number of transactions you want to execute in each work unit.	Yes
Maximum Batch Count	Used to specify the maximum number of transactions after which the data must be transferred to the database.	Yes
Thread Pool Name	Used to specify the thread pool on which you want to execute the batch.	No

**Note:**

You must specify same parameters in the **Service Quantity Calculation (C1-TXNSQ)** and **Mark Completion (C1-TXNCM)** batches. Otherwise, erroneous results might occur.

If you want to perform some post-processing activities on a billable charge, you need to attach a post-processing algorithm on the **TFM - Billable Charge Post-Processing** algorithm entity in the **Algorithms** tab of the **Division** screen. This algorithm is triggered once the billable charge is created and SQIs are updated in the billable charge. Note that the system invokes the algorithm which is attached on the derived account's division and not on the division to which the transaction belongs. A sample post-processing algorithm type named **C1\_BCHG\_POPC** is shipped with the product. It does not have any business logic. If you want to undertake some post-processing activities on a billable charge, you need to create custom algorithm type and attach the respective algorithm on the **Feed Management Billable Charge Post-Processing** algorithm spot of the respective division. You can refer to the **C1\_BCHG\_POPC** algorithm type to understand the input parameters that must be passed to the custom algorithm type.

**Related Topics**

For more information on...	See...
Transaction Leg Status Transition	<a href="#">Transaction Leg Status Transition</a> on page 903

## Clean Up

There might be situations when a transaction is mapped to one or more price items and due to some reasons a billable charge could not be created for one of the price item. And, therefore the status of the transaction is changed to **Error (EROR)**. In such case, you need to either recalculate SQIs in the aggregated billable charge or delete the aggregated billable charge depending on whether the aggregated billable charge includes transaction legs in the **Completed (COMP)** status. You can perform this clean up process through a multi-threaded batch named **Clean Up (C1-TXNCU)**.

When the transaction legs in the **Error (EROR)** and **Completed (COMP)** statuses are aggregated together in a billable charge, the **Clean Up (C1-TXNCU)** batch does the following:

Billable charge contain transaction legs with the following set of pricing attributes...	Then....
<b>Ignore Transaction</b> is set to <b>No</b> , <b>Aggregate Transaction</b> is set to <b>Yes</b> , and <b>Rating Criteria</b> is set to <b>Do Not Rate Transactions</b>	The SQIs are recalculated in the billable charge.
<b>Ignore Transaction</b> is set to <b>No</b> , <b>Aggregate Transaction</b> is set to <b>Yes</b> , and <b>Rating Criteria</b> is set to <b>Aggregate transactions and then rate aggregated SQs (AGTR)</b>	The SQIs are recalculated in the billable charge and the rate is determined for aggregated service quantities. Once the rate is determined, pass through charges are calculated and accumulated accordingly.
<b>Ignore Transaction</b> is set to <b>No</b> , <b>Aggregate Transaction</b> is set to <b>Yes</b> , and <b>Rating Criteria</b> is set to <b>Rate individual transactions and aggregate calc lines across transactions (RITA)</b>	The pass through charges are recalculated and accumulated accordingly.

However, when the transaction legs in the **Error (EROR)** status are only aggregated in a billable charge, the **Clean Up (C1-TXNCU)** batch does the following:

Billable charge contain transaction legs with the following set of pricing attributes...	Then....
<b>Ignore Transaction</b> is set to <b>No</b> , <b>Aggregate Transaction</b> is set to <b>Yes</b> , and <b>Rating Criteria</b> is set to <b>Do Not Rate Transactions</b>	The aggregated billable charge is deleted.
<b>Ignore Transaction</b> is set to <b>No</b> , <b>Aggregate Transaction</b> is set to <b>Yes</b> , and <b>Rating Criteria</b> is set to <b>Aggregate transactions and then rate aggregated SQs (AGTR)</b>	The aggregated billable charge and the corresponding calculation lines are deleted.
<b>Ignore Transaction</b> is set to <b>No</b> , <b>Aggregate Transaction</b> is set to <b>Yes</b> , and <b>Rating Criteria</b> is set to <b>Rate individual transactions and aggregate calc lines across transactions (RITA)</b>	The aggregated billable charge is deleted.

**Note:**

If the aggregation function is based on the transaction amount or on any other user defined amount and the transaction or user defined currency is different from the pricing currency, the system does currency conversion if the appropriate exchange rate is available in the system. The processing date which is stamped against a transaction leg is used to determine effective exchange rate for the transaction leg.

The SQIs in an aggregated billable charge are recalculated only when the **SQ Recalculation Required** option type in the **C1\_FM** feature configuration is set to **Y**. If you set the **SQ Recalculation Required** option type in the **C1\_FM** feature configuration to **N**, the SQIs are not recalculated in an aggregated billable charge. We recommend you to recalculate SQIs in an aggregated billable charge when more than one account bears the charges for a transaction.

If you want to perform some post-processing activities on a billable charge, you need to attach a post-processing algorithm on the **TFM - Billable Charge Post-Processing** algorithm entity in the **Algorithms** tab of the **Division** screen. This algorithm is triggered once the billable charge is created and SQIs are updated in the billable charge. Note that the system invokes the algorithm which is attached on the derived account's division and not on the division to which the transaction belongs. A sample post-processing algorithm type named **C1\_BCHG\_POPC** is shipped with the product. It does not have any business logic. If you want to undertake some post-processing activities on a billable charge, you need to create custom algorithm type and attach the respective algorithm on the **TFM - Billable Charge Post-Processing** algorithm spot of the respective division. You can refer to the **C1\_BCHG\_POPC** algorithm type to understand the input parameters that must be passed to the custom algorithm type.

Besides the transaction aggregation process, the **Clean Up (C1-TXNCU)** batch is also used during the following sub-processes:

- **Cancellation** — During the cancellation process, it deletes non-aggregated billable charges and recalculates SQIs in aggregated billable charges.
- **Disaggregation** — During the disaggregation process, it deletes an aggregated billable charge when all the corresponding transaction legs which were aggregated in the billable charge are deleted during disaggregation.

You can specify either of the following parameters while executing the **Clean Up (C1-TXNCU)** batch:

Parameter Name	Description	Mandatory (Yes or No)
Transaction Header ID	Used when you want to update or delete billable charges created for transactions which are received in a particular transaction feed.  <b>Note:</b> This parameter should not be used during the disaggregation process.	Yes (Conditional)  <b>Note:</b> This parameter is required when you set the request type to <b>CNCL</b> .
Transaction Source	Used when you want to update or delete billable charges created for transactions which are received from a particular transaction source.  <b>Note:</b> This parameter should not be used during the cancellation and disaggregation processes.	No
Division	Used when you want to update or delete billable charges created for transactions belonging to a particular division.  <b>Note:</b> This parameter should not be used during the cancellation process.	No



Parameter Name	Description	Mandatory (Yes or No)
Account ID	Used when you want to update or delete billable charges created for transactions of a particular account.  <b>Note:</b> This parameter should be used only during the disaggregation process.	No
Bill Cycle	Used when you want to update or delete billable charges created for transactions of accounts having a particular bill cycle.  <b>Note:</b> This parameter should be used only during the disaggregation process.	No
Disaggregate Transactions From Date	Used when you want to update or delete billable charges created for transactions which were performed from a particular date onwards.  <b>Note:</b> You must specify the date in the YYYY-MM-DD format. This parameter should be used only during the disaggregation process.	Yes (Conditional)  <b>Note:</b> This parameter is required when you set the request type to <b>DISAGG</b> .
Request Type	Used to indicate the process during which you want to execute the batch. The valid values are: <ul style="list-style-type: none"> <li>• CNCL</li> <li>• EROR</li> <li>• DISAGG</li> </ul>	Yes
Chunk Size	Used to specify the number of transactions you want to execute in each work unit.	Yes
Maximum Batch Count	Used to specify the maximum number of transactions after which the data must be transferred to the database.	Yes
Thread Pool Name	Used to specify the thread pool on which you want to execute the batch.	No

### **Related Topics**

For more information on...	See...
Transaction Leg Status Transition	<a href="#">Transaction Leg Status Transition</a> on page 903
How to set the C1_FM feature configuration	<a href="#">Setting the C1_FM Feature Configuration</a> on page 2910

## **Transaction Aggregation Batch Processing**

During the transaction aggregation process, you need to execute the following batches in the specified order:

1. Flush All Caches (F1-FLUSH)
2. Refresh Pricing (C1-TXNRP)
3. Header Validation (C1-TXNHV)

4. Validate Transaction and Derive Price Item (C1-TXNIP)
5. Price Item Pricing Verification (C1-TXNVP)
6. Update Status (C1-TXNEX)
7. Service Quantity Calculation (C1-TXNSQ)
8. Mark Completion (C1-TXNCM)
9. Clean Up (C1-TXNCU) with the **Request Type** parameter set to **EROR**

The **Validate Transaction and Derive Price Item (C1-TXNIP)** batch locks the **CI\_TXN\_DTL\_PRITM\_SUMMARY** table before inserting records to ensure that only unique records are inserted in this table. The locking mechanism results in performance issue when there is no or very little aggregation of transactions. Therefore, we recommend you to use an alternative transaction aggregation process when the aggregation ratio is low. You can enable the alternative transaction aggregation process by setting the **Use C1-TXNPS During Transaction Aggregation** option type in the **C1\_FM** feature configuration to **true**. In this alternative transaction aggregation process, you need to execute the following batches in the specified order:

1. Flush All Caches (F1-FLUSH)
2. Refresh Pricing (C1-TXNRP)
3. Header Validation (C1-TXNHV)
4. Validate Transaction and Derive Price Item (C1-TXNIP)
5. Populate CI\_TXN\_DTL\_PRITM\_SUMMARY Table (C1-TXNPS)
6. Price Item Pricing Verification (C1-TXNVP)
7. Update Status (C1-TXNEX)
8. Service Quantity Calculation (C1-TXNSQ)
9. Mark Completion (C1-TXNCM)
10. Clean Up (C1-TXNCU) with the **Request Type** parameter set to **EROR**

The following figure graphically explains the sequence in which you need to execute the batches during the transaction aggregation process:

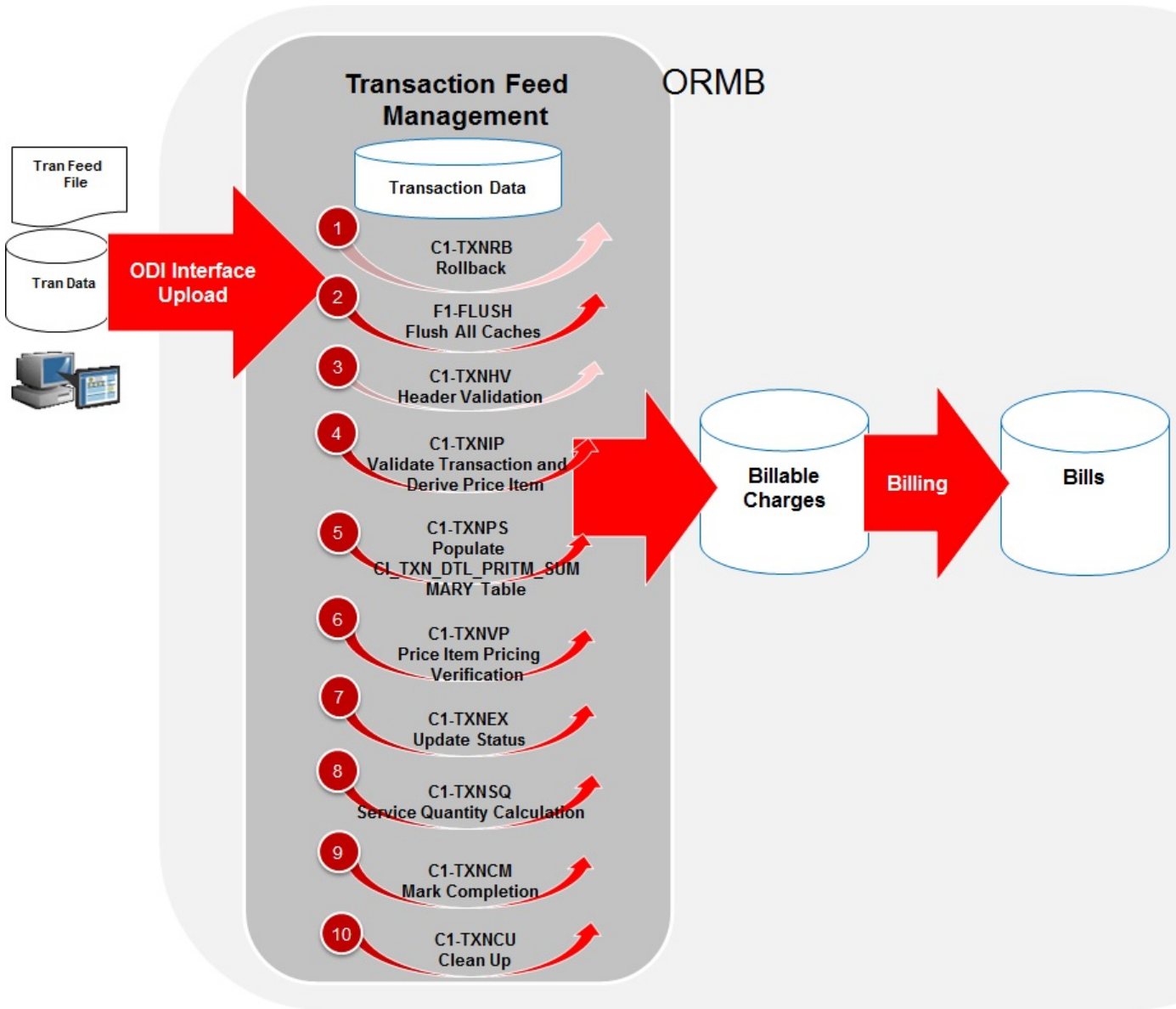

**Note:**

You need to remember the following points during the transaction aggregation process:

- Before you start the transaction aggregation process, you need to execute the **Flush All Caches (F1-FLUSH)** batch to clean the cache. This batch has one parameter named **Thread Pool** which allows you to clean cache of a particular thread pool. In case you want to reprocess the error transactions from the earlier cycle, you need to execute the **Rollback (C1-TXNRB)** batch.
- You can store the price item pricing information, and thereby improve the **Price Item Pricing Verification (C1-TXNVP)** batch performance. If you set the **Use Materialized Views** option type of the **C1\_FM** feature configuration to **true**, the system will store the price item pricing information in the following tables:
  - CI\_PRC\_AGRD
  - CI\_PRC\_PL
  - CI\_PRC\_INH\_PL

But, if you set the **Use Materialized Views** option type of the **C1\_FM** feature configuration to **false**, the system will not store the price item pricing information in the above mentioned tables. If there are any pricing changes, you can update the price item pricing information in these tables by executing the **Refresh Pricing (C1-TXNRP)** batch.

- The **Header Validation (C1-TXNHV)** batch is optional. You can directly execute the **Validate Transaction and Derive Price Item (C1-TXNIP)** batch once the transactions are uploaded in the system.
- The system allows you to execute each batch consecutively. You can execute the **Validate Transaction and Derive Price Item (C1-TXNIP)** batch consecutively with the same division and same parameters, or with the different division and different parameters. But, you cannot execute the **Validate Transaction and Derive Price Item (C1-TXNIP)** batch consecutively with the same division and different parameters. For example, once you execute this batch with division as D1 and transaction source as S1, you cannot execute this batch again with division as D1 and transaction source as S2 until the former transaction aggregation cycle is complete.
- Once the **Price Item Pricing Verification (C1-TXNVP)** batch is executed, you cannot execute the **Validate Transaction and Derive Price Item (C1-TXNIP)** batch again with the same division and same parameters unless and until the transaction aggregation cycle is complete. Similarly, once the **Service Quantity Calculation (C1-TXNSQ)** batch is executed, you cannot execute the **Price Item Pricing Verification (C1-TXNVP)** batch again with the same division and same parameters unless and until the transaction aggregation cycle is complete. This rule is applicable to all subsequent batches in the transaction aggregation cycle.
- During the transaction aggregation process, you must specify the same division and same parameters across each batch. Otherwise, erroneous results might occur.
- If you have already executed the **Validate Transaction and Derive Price Item (C1-TXNIP)** batch without any division, then you cannot execute this batch once again with a division unless and until the transaction aggregation cycle is complete.

## Transaction Disaggregation

As the aggregation cycle is different from the billing cycle, there might be situations when due to pricing changes, the billable charges are no longer valid. In such cases, you need to disaggregate the transactions. In the following scenarios, the system automatically creates a disaggregation request in the CI\_TXN\_DISAGG\_REQ table:

If...	Then
A price item is assigned to an account	A disaggregation request is created for the account.

If...	Then
<p>The following values in the price item pricing assigned to an account is changed:</p> <ul style="list-style-type: none"> <li>• Effective Start Date</li> <li>• Effective End Date</li> <li>• Aggregation Schedule</li> <li>• Ignore Transaction</li> <li>• Aggregate Transaction</li> <li>• Rating Criteria</li> <li>• Price Item Parameter</li> </ul>	<p>A disaggregation request is created for the account.</p>
<p>A price item is assigned to a person</p>	<p>A disaggregation request is created for each account of the person and its child person.</p>
<p>The following values in the price item pricing assigned to a person is changed:</p> <ul style="list-style-type: none"> <li>• Effective Start Date</li> <li>• Effective End Date</li> <li>• Aggregation Schedule</li> <li>• Ignore Transaction</li> <li>• Aggregate Transaction</li> <li>• Rating Criteria</li> <li>• Price Item Parameter</li> </ul>	<p>A disaggregation request is created for each account of the person and its child person.</p>
<p>A price list is assigned to an account.</p>	<p>A disaggregation request is created for the account.</p>
<p>The following values in the price list assigned to an account is changed:</p> <ul style="list-style-type: none"> <li>• Effective Start Date</li> <li>• Effective End Date</li> <li>• Priority</li> <li>• Price List Inheritance</li> </ul>	<p>A disaggregation request is created for the account.</p>
<p>A price list is assigned to a person.</p>	<p>A disaggregation request is created for each account of the person and its child person.</p>
<p>The following values in the price list assigned to a person is changed:</p> <ul style="list-style-type: none"> <li>• Effective Start Date</li> <li>• Effective End Date</li> <li>• Priority</li> <li>• Price List Inheritance</li> </ul>	<p>A disaggregation request is created for each account of the person and its child person.</p>

However, there are various other scenarios for which you have to disaggregate the transactions. But, at the moment, the system does not automatically create a disaggregation request for these scenarios in the CL\_TXN\_DISAGG\_REQ table. You will have to create an appropriate disaggregation request in this table. The system allows you to create a

disaggregation request manually through the **Disaggregation Request** screen or through a batch named **Disaggregation Request Creation (C1-DISTG)**.

In the following scenarios, you have to create an appropriate disaggregation request for the account or person, respectively:

- Effective price item pricing assigned to an account is overridden.
- Variance parameter in the price item pricing assigned to an account is changed.
- A price list assignment has expired or a price list is no longer available to an account.
- Effective price item pricing assigned to a person is overridden.
- Variance parameter in the price item pricing assigned to a person is changed.
- A price list assignment has expired or a price list is no longer available to a person.
- A price item is added to a price list.
- The following details in the price item pricing assigned to a price list is changed:
  - Variance Parameter
  - Effective Start Date
  - Effective End Date
  - Aggregation Schedule
  - Ignore Transaction
  - Rating Criteria
  - Aggregate Transaction
- A new bundle is created.
- A price item is added to a bundle.
- A price item is removed from a bundle.
- A bundle is eliminated (that is, all its price item are removed).
- A price item is added.
- A price list hierarchy is changed.
- SQIs associated with a price item - division combination are changed.
- Transaction aggregation rule defined for an SQI is changed or deleted.
- Business rules used for initial price item mapping are changed.

At present, the system disaggregates transactions at the account level and not at the price item level. Let us understand this with the help of an example. The following table lists the accounts and price items to which T1 is mapped:

Transaction	Account	Price Item
T1	A1	P1
T1	A1	P2
T1	A2	P1
T1	A2	P2

Now, if the pricing of P1 assigned to A1 changes, the system creates a disaggregation request for A1 and identifies all transaction legs which are mapped to A1 for disaggregation. In this example, the system will consider the first two transaction legs - T1-A1-P1 and T1-A1-P2 - for disaggregation even if the pricing of P2 assigned to A1 has not changed.

The **Disaggregation Request Creation (C1-DISTG)** batch creates a disaggregation request for an account. When you create a disaggregation request for an account, the transactions mapped to the account are disaggregated. This batch is a multi-threaded batch. The multi-threading is based on account ID and chunks for multi-threading are created based on numerical distribution of account ID. You can specify either of the following parameters while executing this batch:

Parameter Name	Description	Mandatory (Yes or No)
Division	Used when you want to create disaggregation request for accounts belonging to a particular division.	No
Person ID	Used when you want to create disaggregation request for accounts belonging to a particular person.	No
Bill Cycle	Used when you want to create disaggregation request for accounts having a particular bill cycle.	No
Disaggregate Transactions From Date	Used when you want to create disaggregation request for accounts for which transactions were performed from a particular date onwards.  <b>Note:</b> You must specify the date in the YYYY-MM-DD format.	Yes
Thread Pool Name	Used to specify the thread pool on which you want to execute the batch.	No

Before you proceed with the disaggregation process, you need to ensure that there are no pending bills for the accounts whose transactions need to be disaggregated. If there are pending bills for these accounts, you need to first execute the **Pending Bill Segments Deletion (C1-BSEGD)** batch and then execute the **Pending Bill Deletion (C1-PNBD)** batch. While executing these batches in the specified order, ensure that you specify the same parameters in both these batches. For more information about these batches, see *Oracle Revenue Management and Billing Batch Execution Guide*.

**Note:** The **Pending Bill Deletion (C1-PNBD)** batch deletes those pending bills which are generated through the billing batches (i.e. **BILLING** or **C1-PNDBL**). It does not delete pending bills which are generated through the user interface. Also, it deletes regular pending bills and not adhoc pending bills.

Once a disaggregation request is either manually or automatically created for an account, you need to execute the following batches in the specified order to disaggregate transactions:

- **Identify Transactions for Disaggregation (C1-IDENT)** - This batch fetches disaggregation requests which are created for accounts from the CI\_TXN\_DISAGG\_REQ table. It identifies the transactions and the corresponding aggregated and non-aggregated billable charges for disaggregation. If the bill segment of a billable charge is in the **Pending Cancel** or **Frozen** status, the system will not identify the billable charge for deletion. You can specify either of the following parameters while executing this batch:

Parameter Name	Description	Mandatory (Yes or No)
Division	Used when you want to identify the transactions of accounts belonging to a particular division for disaggregation.	No
Account ID	Used when you want to identify the transactions of a particular account for disaggregation.	No
Bill Cycle	Used when you want to identify the transactions of accounts having a particular bill cycle for disaggregation.	No

Parameter Name	Description	Mandatory (Yes or No)
Disaggregate Transactions From Date	<p>Used when you want to identify the transactions which were performed from a particular date onwards for disaggregation.</p> <div style="border: 1px solid black; padding: 5px;"> <p><b>Note:</b> You must specify the date in the YYYY-MM-DD format.</p> <p>The aggregated billable charge, which is affected, should not contain a transaction leg whose transaction date is earlier than the date specified in this parameter. Otherwise, erroneous results will occur. Therefore, ensure that you specify the appropriate value for the <b>Disaggregate Transactions From Date</b> parameter.</p> </div>	No
Chunk Size	Used to specify the number of transactions you want to execute in each work unit.	Yes
Maximum Batch Count	Used to specify the maximum number of transactions after which the data must be transferred to the database.	Yes
Post-Processing Algorithm	Used to attach a post-processing algorithm. This algorithm is triggered once the transactions and corresponding billable charges are identified for disaggregation.	No
Exclude Canceled Billable Charges (Y or N)	<p>Used to indicate whether you want to exclude the aggregated and non-aggregated billable charges which are in the <b>Canceled</b> status during the disaggregation process. The valid values are:</p> <ul style="list-style-type: none"> <li>• Y</li> <li>• N</li> </ul> <div style="border: 1px solid black; padding: 5px;"> <p><b>Note:</b> If you do not specify any value, by default, the parameter value is set to N.</p> </div>	No
Thread Pool Name	Used to specify the thread pool on which you want to execute the batch.	No

- **Process Non-Aggregated Transactions (C1-PDTXN)** - This batch processes the identified transactions, deletes the required transaction legs, and changes the status of the transaction to **Uploaded (UPLD)**. If a non-aggregated billable charge exists for a transaction leg and the corresponding bill segment is in the **Cancel** status, then:
  - The billable charge is cancelled.
  - The corresponding transaction leg and calculation lines (if any) are deleted.
  - The status of the transaction is changed to **Uploaded (UPLD)**.

However, if a non-aggregated billable charge exists for a transaction leg, but if the bill segment is not yet generated, then the billable charge, the corresponding calculation lines (if any), and transaction leg are deleted, and the status of the transaction is changed to **Uploaded (UPLD)**. If a non-aggregated billable charge is in the **Cancel** status, then the corresponding transaction leg and calculation lines (if any) are deleted and the status of the transaction is changed to **Uploaded (UPLD)**. If the rate is determined for a transaction leg which is in the **Ignored (IGNR)** status, the calculation lines are deleted along with the transaction leg during disaggregation.



If aggregated billable charge exists for a transaction leg, then the corresponding transaction legs and calculation lines (if any) are deleted and the status of the transaction is changed to **Uploaded (UPLD)**. You can specify either of the following parameters while executing this batch:

Parameter Name	Description	Mandatory (Yes or No)
Division	Used when you want to disaggregate the transactions of accounts belonging to a particular division.	No
Account ID	Used when you want to disaggregate the transactions of a particular account.	No
Bill Cycle	Used when you want to disaggregate the transactions of accounts having a particular bill cycle.	No
Disaggregate Transactions From Date	Used when you want to disaggregate the transactions which were performed from a particular date onwards.  <b>Note:</b> You must specify the date in the YYYY-MM-DD format.	Yes
Chunk Size	Used to specify the number of transactions you want to execute in each work unit.	Yes
Maximum Batch Count	Used to specify the maximum number of transactions after which the data must be transferred to the database.	Yes
Thread Pool Name	Used to specify the thread pool on which you want to execute the batch.	No

**Note:**

If you want to undertake some preprocessing activities (such as cleaning data in any custom tables) during the disaggregation process, you need to attach a preprocessing algorithm on the **TFM - Disaggregation Pre-Processing** algorithm entity in the **Algorithms** tab of the **Division** screen. This algorithm is triggered when you execute the **Process Non-Aggregated Transactions (C1-PDTXN)** batch. Note that the system invokes the algorithm which is attached on the derived account's division and not on the division to which the transaction belongs.

A sample preprocessing algorithm type named **C1\_DSAG\_PRPC** is shipped with the product. It does not have any business logic. If you want to undertake some preprocessing activities during the disaggregation process, you need to create custom algorithm type and attach the respective algorithm on the **TFM - Disaggregation Pre-Processing** algorithm spot of the respective division. You can refer to the **C1\_DSAG\_PRPC** algorithm type to understand the input parameters that must be passed to the custom algorithm type.

- **Clean Up (C1-TXNCU)** - This batch deletes an aggregated billable charge when all the corresponding transaction legs which were aggregated in the billable charge are deleted during disaggregation. If an aggregated billable charge exists for a transaction leg and the corresponding bill segment is in the **Cancel** status, then:
  - The billable charge is cancelled.
  - The status of the transaction is changed to **Uploaded (UPLD)**.

However, if an aggregated billable charge exists for a transaction leg, but if the bill segment is not yet generated, then the billable charge, and the corresponding calculation lines (if any) are deleted, and the status of the transaction is changed to **Uploaded (UPLD)**. If an aggregated billable charge is in the **Cancel** status, then the corresponding calculation lines (if any) are deleted and the status of the transaction is changed to **Uploaded (UPLD)**.

While executing the **Clean Up (C1-TXNCU)** batch during disaggregation, you must set the **Request Type** parameter to **DISAGG**. For more information about the parameters that you can specify while executing this batch, refer to [Clean Up](#) on page 879.

- **Update Disaggregation Request Status (C1-DRSUA)** - This batch changes the status of the disaggregation request in the **CI\_TXN\_DISAGG\_REQ** table to **COMPLETE**. You can specify either of the following parameters while executing this batch:

Parameter Name	Description	Mandatory (Yes or No)
Account ID	Used when you want to update the disaggregation requests' status of a particular account.	No
Division	Used when you want to update the disaggregation requests' status of accounts belonging to a particular division.	No
Bill Cycle	Used when you want to update the disaggregation requests' status of accounts having a particular bill cycle.	No
Disaggregate Transactions From Date	Used when you want to update the disaggregation requests' status of accounts whose transactions were performed from a particular date onwards and the bill segments created for these transactions are in the <b>Pending Cancel</b> or <b>Frozen</b> status.  <b>Note:</b> You must specify the date in the YYYY-MM-DD format.	Yes
Chunk Size	Used to specify the number of transactions you want to execute in each work unit.	Yes
Update Status Algorithm	Used to attach a custom algorithm which indicates when the status of the disaggregation request in the <b>CI_TXN_DISAGG_REQ</b> table must be changed to <b>COMPLETE</b> .  <b>Note:</b> If an algorithm is specified in this parameter, the system uses the custom logic and not the in-built logic for updating the status of the disaggregation requests.	No
Exclude Canceled Billable Charges (Y or N)	Used to indicate whether you want to change the status of the disaggregation request to <b>COMPLETE</b> when the canceled billable charges are excluded during the disaggregation process. The valid values are:  <ul style="list-style-type: none"> <li>• Y</li> <li>• N</li> </ul> <b>Note:</b> If you do not specify any value, by default, the parameter value is set to N.  You must specify the same value for this parameter while executing the <b>Identify Transactions for Disaggregation (C1-IDENT)</b> and <b>Update Disaggregation Request Status (C1-DRSUA)</b> batches during the disaggregation process. Otherwise, erroneous results will occur.	No

Parameter Name	Description	Mandatory (Yes or No)
Thread Pool Name	Used to specify the thread pool on which you want to execute the batch.	No

### **Related Topics**

For more information on...	See...
Transaction Leg Status Transition	<a href="#">Transaction Leg Status Transition</a> on page 903
How to create a disaggregation request manually	<a href="#">Creating a Disaggregation Request</a> on page 1030

## **Transaction Disaggregation Batch Processing**

---

During the transaction disaggregation process, you need to execute the following batches in the specified order:

1. Disaggregation Request Creation (C1-DISTG)
2. Pending Bill Segments Deletion (C1-BSEGD)
3. Pending Bill Deletion (C1-PNBD)
4. Identify Transactions for Disaggregation (C1-IDENT)
5. Process Non-Aggregated Transactions (C1-PDTXN)
6. Clean Up (C1-TXNCU) with the **Request Type** parameter set to **DISAGG**
7. Update Disaggregation Request Status (C1-DRSUA)

The following figure graphically explains the sequence in which you need to execute the batches during the transaction disaggregation process:

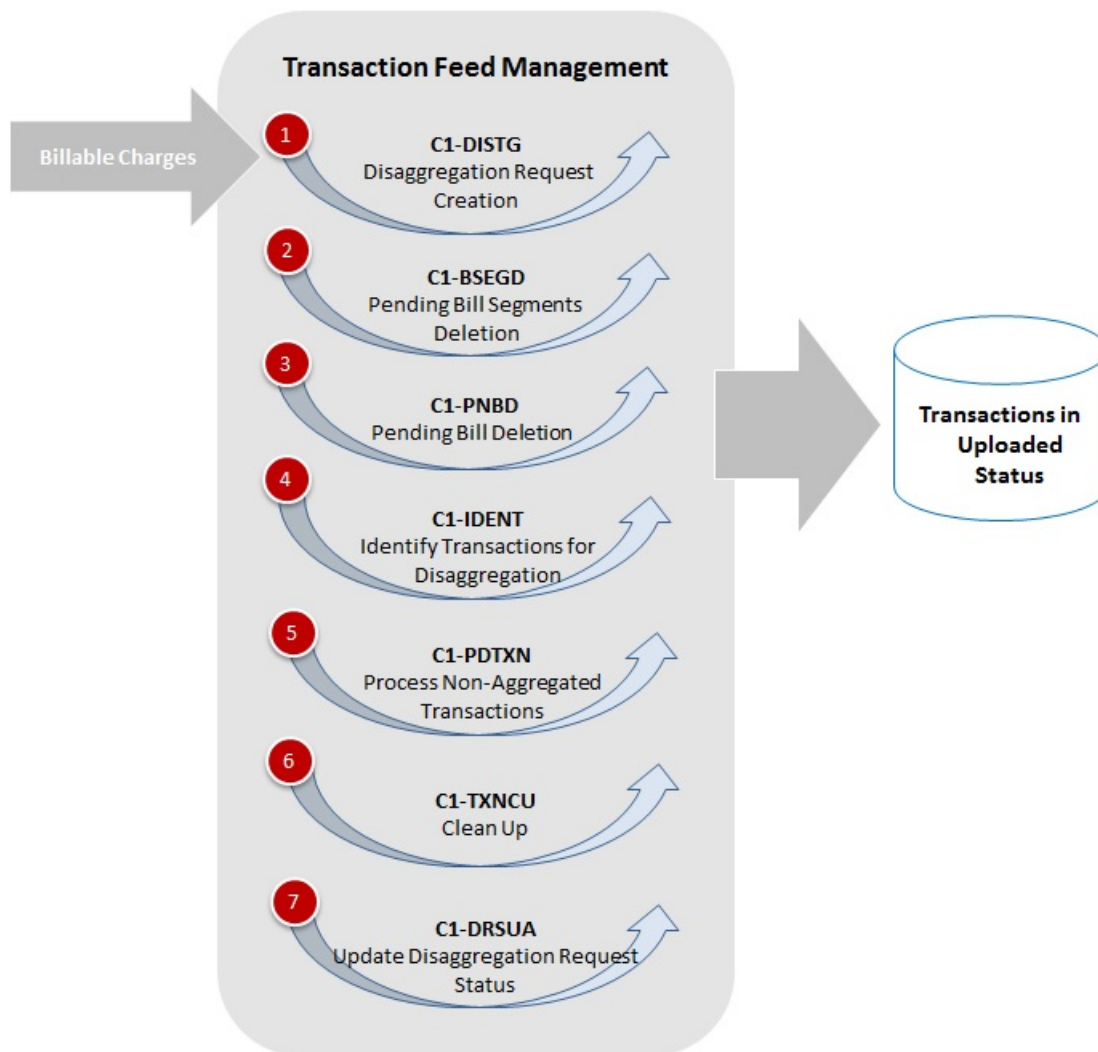

## Reseeding

In the self-funded health care business, there might be situations when you may want to disaggregate the claim, enrollment, and ancillary transactions. The system enables you to disaggregate the claim, enrollment, and ancillary transactions until these transactions are not billed to the customer. If a transaction is billed to the customer, you cannot disaggregate the transaction using the normal transaction disaggregation process.

In the following scenarios, you may want to disaggregate the claim or ancillary transactions once these are billed to the customer:

- The changes are made to the specific stop-loss (SSL), aggregate stop-loss (ASL), discount arrangement, or level funded pricing rule which is used during the transaction aggregation process.
- A new pricing rule is created using a specific stop-loss (SSL) or aggregate stop-loss (ASL) pricing rule type which is added in the claim or ancillary pricing rule type using which the claim or ancillary transaction is processed.
- A new pricing rule is created using a discount arrangement pricing rule type which is added in the claim or ancillary pricing rule type using which the claim or ancillary transaction is processed.
- A new pricing rule is created using a level funded pricing rule type which is added in the claim or ancillary pricing rule type using which the claim or ancillary transaction is processed.

- A specific stop-loss, aggregate stop-loss, discount arrangement, or level funded pricing rule type is added as related pricing rule type in the claim or ancillary pricing rule type using which the claim or ancillary transaction is processed.

The former scenario arises due to change in pricing rule, whereas the latter four scenarios arise due to the late setup. In such scenarios, you can create the **Accumulation Group Based Disaggregation Request** (also known as **Reseeding Request**) to disaggregate the claim and ancillary transactions. In the **Accumulation Group Based Disaggregation** (also known as **Reseeding**) feature, the system allows you to create the reseeding requests for the accounts using a parent accumulation group. At present, you can create the reseeding requests for the accounts only from the user interface and not through the **Disaggregation Request Creation (C1-DISTG)** batch.

While creating a reseeding request using the **Parent Accumulation Group** request type, you can specify the accumulation type (i.e. whether it is stop-loss or discount arrangement). If the accumulation type is set to **Stop Loss**, the system provides the **Disaggregate All Account** option. If you select the **Disaggregate All Account** option, the system considers accounts of all bill groups of the parent customer (for whom the parent accumulation group is created) and then creates a reseeding request for each such account. However, if you do not select the **Disaggregate All Account** option, the system considers accounts of only those bill groups where the parent accumulation group is used for creating the specific stop-loss and aggregate stop-loss pricing rules and then creates a reseeding request for each such account. In addition, the system creates a reseeding request for the ASSL and ASL Credit accounts which are specified in the specific stop-loss and aggregate stop-loss pricing rules, respectively. Note that the reseeding requests are created for the ASSL and ASL Credit accounts irrespective of whether the **Disaggregate All Account** option is selected or not.

However, if the accumulation type is set to **Discount Arrangement**, the system does not provide the **Disaggregate All Account** option. In this case, the system, by default, considers accounts of all bill groups of the parent customer (for whom the parent accumulation group is created) and then creates a reseeding request for each such account.

**Note:** In the late setup scenarios, you need to ensure that the pricing rules are created before you create the reseeding requests for accounts.

In the **Reseeding** process, you need to execute the following batches in the specified sequence:

1. **Identify Transactions for Disaggregation (C1-IDENT)** - It fetches the reseeding requests for accounts and then identifies the claim or ancillary transactions for disaggregation. If the reseeding request is created due to change in a pricing rule, the **BILLABLE\_CHG\_ACT\_CD** column corresponding to the specific stop-loss, aggregate stop-loss, discount, or level-funded billable charges in the **CI\_DISAGG\_BCHG\_DETAIL** table is set to **Billable Charge is Part of Frozen Bill Segment (40)**. It indicates that no action must be taken on these billable charges. And, if the reseeding request is created due to the late setup scenarios, the claim or ancillary transaction and its legs are moved to the **CI\_TXN\_DETAIL\_STG** and **CI\_TXN\_DTL\_PRITM\_STG** tables, respectively. In addition, the status of the claim or ancillary transaction is changed to **Uploaded**. For more information about the parameters, refer to *ORMB - Transaction Feed Management - Batch Execution Guide*.
2. **Process Non-Aggregated Transactions (C1-PDTXN)** - If the reseeding request is created due to change in a pricing rule, it does the following:
  - The specific stop-loss, aggregate stop-loss, discount arrangement, and stop-loss and discount specific level funded transaction legs, whose corresponding bill segments are in the **Frozen** or **Pending Cancel** status, are forcibly deleted from the **CI\_TXN\_DTL\_PRITM** table.
  - The specific stop-loss, aggregate stop-loss, discount arrangement, and stop-loss and discount specific level funded transaction legs, whose corresponding bill segments are in a status other than **Frozen** or **Pending Cancel**, are moved to the **CI\_TXN\_DTL\_PRITM\_STG** table. And, the claim or ancillary transaction is moved to the **CI\_TXN\_DETAIL\_STG** table and its status is changed to **Uploaded**.

Irrespective of whether the reseeding request is created due to change in a pricing rule or the late setup scenarios, this batch does not perform any actions on the claim, claim based fee, and ancillary transaction legs and their billable charges. For more information about the parameters, refer to *ORMB - Transaction Feed Management - Batch Execution Guide*.

3. **Transaction Cleanup Batch (C1-TXNCU)** - While executing the **Clean Up (C1-TXNCU)** batch during reseeding, you must set the **Request Type** parameter to **DISAGG**. For more information about the parameters, refer to *ORMB - Transaction Feed Management - Batch Execution Guide*.

- 4. Update Disaggregation Request Status (C1-DRSUA)** - Once the claim or ancillary transaction is successfully disaggregated, the status of the reseeded request is changed to **COMPLETE**. For more information about the parameters, refer to *ORMB - Transaction Feed Management - Batch Execution Guide*.

When you re-aggregate the claim or ancillary transactions which were disaggregated due to late setup, the system creates the specific stop-loss, aggregate stop-loss, discount arrangement, and stop-loss and discount specific level funded transaction legs and their billable charges. However, when you re-aggregate the claim or ancillary transactions which were disaggregated due to change in a pricing rule, the system creates the specific stop-loss, aggregate stop-loss, discount arrangement, and stop-loss and discount specific level funded transaction legs and the billable charges for the delta amount (which resulted due to change in pricing).

If the accumulation type is set to **Stop Loss**, the system deletes the specific stop-loss transaction legs. In addition, it deletes the aggregate stop-loss transaction legs (if any), discount arrangement transaction legs (if any), and level funded transaction legs (if any) whose calculation is based on the specific stop-loss transaction legs.

However, if the accumulation type is set to **Discount Arrangement**, the system deletes the discount arrangement transaction legs. It deletes the specific stop-loss transaction legs (if any), aggregate stop-loss transaction legs (if any), and level funded transaction legs (if any) when the discount arrangement pricing rule is used in the specific stop-loss pricing rule. However, it deletes the aggregate stop-loss transaction legs (if any) and level funded transaction legs (if any) when the discount arrangement pricing rule is used in the aggregate stop-loss pricing rule.

For example, the CLAIM pricing rule type contains the SSL, ASL, DISCOUNT, and LEVEL FUNDED pricing rule types as the related pricing rule types, and the SSL and ASL pricing rules contain the following discount arrangement pricing rules:

Discount Arrangement Pricing Rule	Included in the SSL Pricing Rule (Yes or No)	Included in the ASL Pricing Rule (Yes or No)
DISCOUNT1	Yes	No
DISCOUNT2	No	Yes

Now, if the reseeded request (where the accumulation type is set to **Stop Loss**) is created for an account due to change in the SSL pricing rule, the system behaves in the following manner for the C1 claim transaction:

Transaction Leg	Existing Transaction Leg Deleted (Yes or No)	New Transaction Leg Created (Yes or No)	Existing Billable Charge Deleted (Yes or No)	New Billable Charge Created for Delta Charges (Yes or No)
Claim	No	No	No	No
SSL	Yes	Yes	No	Yes
ASL	Yes	Yes	No	Yes
DISCOUNT	No	No	No	No
LEVEL FUNDED	Yes	Yes	No	Yes
DISCOUNT1	Yes	Yes	No	Yes
DISCOUNT2	Yes	Yes	No	Yes

However, if the reseeded request (where the accumulation type is set to **Discount Arrangement**) is created for an account due to change in the DISCOUNT2 pricing rule, the system behaves in the following manner for the C1 claim transaction:

Transaction Leg	Existing Transaction Leg Deleted (Yes or No)	New Transaction Leg Created (Yes or No)	Existing Billable Charge Deleted (Yes or No)	New Billable Charge Created for Delta Charges (Yes or No)
Claim	No	No	No	No
SSL	No	No	No	No
ASL	Yes	Yes	No	Yes
DISCOUNT	No	No	No	No
LEVEL FUNDED	Yes	Yes	No	Yes
DISCOUNT1	No	No	No	No
DISCOUNT2	Yes	Yes	No	Yes

Let us take another example where the related pricing rule types are not specified in the CLM1 pricing rule type. Therefore, the system just created claim-specific transaction legs and billable charges for the C2 claim transaction. These claim billable charges are then billed to the customer. Now, if you add the SSL and ASL pricing rule types as the related pricing rule types in the CLM1 pricing rule type and create a reseeding request (where the accumulation type is set to **Stop Loss**) for an account, the system behaves in the following manner for the C2 claim transaction when the transaction incurred and paid dates fall within the incurred and paid date ranges defined in the parent accumulation group:

Transaction Leg	Existing Transaction Leg Deleted (Yes or No)	New Transaction Leg Created (Yes or No)	Existing Billable Charge Deleted (Yes or No)	New Billable Charge Created for Delta Charges (Yes or No)
Claim	No	No	No	No
SSL	Not applicable	Yes	Not applicable	Yes
ASL	Not applicable	Yes	Not applicable	Yes
DISCOUNT1	Not applicable	Yes	Not applicable	Yes
DISCOUNT2	Not applicable	Yes	Not applicable	Yes

## Transaction Cancellation

There might be situations when incorrect transaction data file is uploaded in the system. In such cases, the system provides you with an ability to cancel the whole transaction feed. You can cancel a transaction feed either before the transaction aggregation process starts (that is, before executing the **Validate Transaction and Derive Price Item (C1-TXNIP)** batch) or after the transaction aggregation process ends (that is, after executing the **Clean Up (C1-TXNCU)** batch). In other words, you cannot cancel a transaction feed during the transaction aggregation process. Once the transaction feed is cancelled, the status of the feed and all transactions in the feed is changed to **Cancelled (CNCL)**.

The following table explains how the system behaves:

When you cancel a transaction feed for which...	Then
<p>A bill (with the <b>Pending</b> status) is already generated in the system</p>	<p>The corresponding billable charges, bill segments, and bill are deleted. The corresponding transaction legs and their calculation lines (if any) are deleted, and the status of the transactions is changed to <b>Cancelled (CNCL)</b>.</p> <div style="border: 1px solid black; padding: 5px;"> <p><b>Note:</b></p> <p>If a pending bill has a bill segment in the <b>Frozen</b> or <b>Pending Cancel</b> status, the system does not allow you to cancel the transaction feed.</p> <p>If a pending bill has a bill segment in the <b>Cancel</b> status, the system behaves in the following manner:</p> <ul style="list-style-type: none"> <li>• Deletes all other bill segments which are not in the <b>Cancel</b> status.</li> <li>• The billable charge corresponding to the bill segment which is not in the <b>Cancel</b> status is deleted if the billable charge is in the <b>Billable</b> status and if the billable charge only includes transactions from the feed that you want to cancel.</li> <li>• The billable charge corresponding to the bill segment which is not in the <b>Cancel</b> status is not deleted or recalculated if the billable charge is in the <b>Cancelled</b> status.</li> <li>• The billable charge corresponding to the bill segment which is in the <b>Cancel</b> status is cancelled if the billable charge only includes transactions from the feed that you want to cancel.</li> <li>• The SQIs in the billable charge are recalculated if the billable charge includes transactions from multiple feeds.</li> </ul> <p>If a bill is created for transactions which are uploaded through multiple transaction feeds (for example, Feed A and Feed B and you want to cancel Feed A), then:</p> <ul style="list-style-type: none"> <li>• The bill and their corresponding bill segments are deleted.</li> <li>• The SQIs are recalculated in the corresponding billable charges.</li> <li>• The legs of transactions uploaded through Feed A and the corresponding calculation lines (if any) are deleted.</li> <li>• The status of the transactions uploaded through Feed A is changed to <b>Cancelled (CNCL)</b>.</li> <li>• The status of Feed A is changed to <b>Cancelled (CNCL)</b>.</li> <li>• The status of the transactions uploaded through Feed B remains the same (i.e. <b>Completed (COMP)</b> ).</li> </ul> </div>
<p>A bill (with the <b>Complete</b> status) already exists in the system</p>	<p>The system does not allow you to cancel the transaction feed.</p>



When you cancel a transaction feed for which...	Then
A bill (with the <b>Complete</b> status) has all bill segments in the <b>Cancelled</b> status	The corresponding billable charges are cancelled. The corresponding transaction legs and their calculation lines (if any) are deleted, and the status of the transactions is changed to <b>Cancelled (CNCL)</b> .
A billable charge (with the <b>Billable</b> status) exists in the system	<p>The billable charge is deleted. The corresponding transaction legs and their calculation lines (if any) are deleted, and the status of the transactions is changed to <b>Cancelled (CNCL)</b>.</p> <div style="border: 1px solid black; padding: 5px;"> <p><b>Note:</b></p> <p>In case a billable charge is created for transactions uploaded through multiple transaction feeds (for example, Feed A and Feed B and you want to cancel Feed A), then:</p> <ul style="list-style-type: none"> <li>• The SQIs are recalculated in the billable charge.</li> <li>• The legs of transactions uploaded through Feed A and the corresponding calculation lines (if any) are deleted.</li> <li>• The status of the transactions uploaded through Feed A is changed to <b>Cancelled (CNCL)</b>.</li> <li>• The status of Feed A is changed to <b>Cancelled (CNCL)</b>.</li> <li>• The status of the transactions uploaded through Feed B remains the same (i.e. <b>Completed (COMP)</b> ).</li> </ul> </div>
A billable charge (with the <b>Cancelled</b> status) exists in the system	The billable charge is not deleted. However, the corresponding transaction legs and their calculation lines (if any) are deleted and the status of the transactions is changed to <b>Cancelled (CNCL)</b> .

To cancel a transaction feed, you need to execute the following batches in the specified order:

- Pending Bill Deletion (C1-DELBL)** — This batch deletes the bills (with the **Pending** status) and their corresponding bill segments. You can specify either of the following parameters while executing this batch:

Parameter Name	Description	Mandatory (Yes or No)
Transaction Header ID	Used when you want to delete bills which include charges for transactions which are received in a particular transaction feed.	Yes
Chunk Size	Used to specify the number of transactions you want to execute in each work unit.	Yes
Maximum Batch Count	Used to specify the maximum number of transactions after which the data must be transferred to the database.	Yes
Thread Pool Name	Used to specify the thread pool on which you want to execute the batch.	No

- Clean Up (C1-TXNCU)** — This batch deletes non-aggregated and aggregated billable charges. An aggregated billable charge is deleted only when it includes legs of transactions from the feed that you want to cancel. If an aggregated billable charge includes legs of transactions from multiple feeds, the SQIs and calculation lines (if any) are recalculated in the aggregated billable charge. The corresponding calculation lines are deleted whenever an aggregated billable charge, which includes transaction legs whose rating criteria is set to **Aggregate transactions and then rate aggregated SQs (AGTR)**, is cancelled or deleted during the cancellation process. Note that while executing this batch, the **Request Type** parameter must be set to **CNCL**. For more information about the parameters that you can specify while executing this batch, refer to [Clean Up](#) on page 879.

3. **Cancellation (C1-TXCNC)** — This batch deletes the transaction legs. The corresponding calculation lines are deleted whenever an aggregated billable charge, which includes transaction legs whose rating criteria is set to **Rate individual transactions and aggregate calc lines across transactions (RITA)** or **Rate Transactions (RITX)**, is cancelled or deleted during the cancellation process. Finally, this batch changes the status of the feed and all transactions in the feed to **Cancelled (CNCL)**. You can specify either of the following parameters while executing this batch:

Parameter Name	Description	Mandatory (Yes or No)
Transaction Header ID	Used when you want to cancel a particular transaction feed.	Yes
Chunk Size	Used to specify the number of transactions you want to execute in each work unit.	Yes
Maximum Batch Count	Used to specify the maximum number of transactions after which the data must be transferred to the database.	Yes
Thread Pool Name	Used to specify the thread pool on which you want to execute the batch.	No

**Note:**

If you want to undertake some preprocessing activities (such as cleaning data in any custom tables) during the cancellation process, you need to attach a preprocessing algorithm on the **TFM - Cancellation Pre-Processing** algorithm entity in the **Algorithms** tab of the **Division** screen. This algorithm is triggered when you execute the **Cancellation (C1-TXCNC)** batch. Note that the system invokes the algorithm which is attached on the derived account's division and not on the division to which the transaction belongs.

A sample preprocessing algorithm type named **C1\_CNCL\_PRPC** is shipped with the product. It does not have any business logic. If you want to undertake some preprocessing activities during the cancellation process, you need to create custom algorithm type and attach the respective algorithm on the **TFM - Cancellation Pre-Processing** algorithm spot of the respective division. You can refer to the **C1\_CNCL\_PRPC** algorithm type to understand the input parameters that must be passed to the custom algorithm type.

**Related Topics**

For more information on...	See...
Transaction Leg Status Transition	<a href="#">Transaction Leg Status Transition</a> on page 903

## Transaction Cancellation Batch Processing

---

During the transaction cancellation process, you need to execute the following batches in the specified order:

1. Pending Bill Deletion (C1-DELBL)
2. Clean Up (C1-TXNCU) with the **Request Type** parameter set to **CNCL**
3. Cancellation (C1-TXCNC)

The following figure graphically explains the sequence in which you need to execute the batches during the transaction cancellation process:

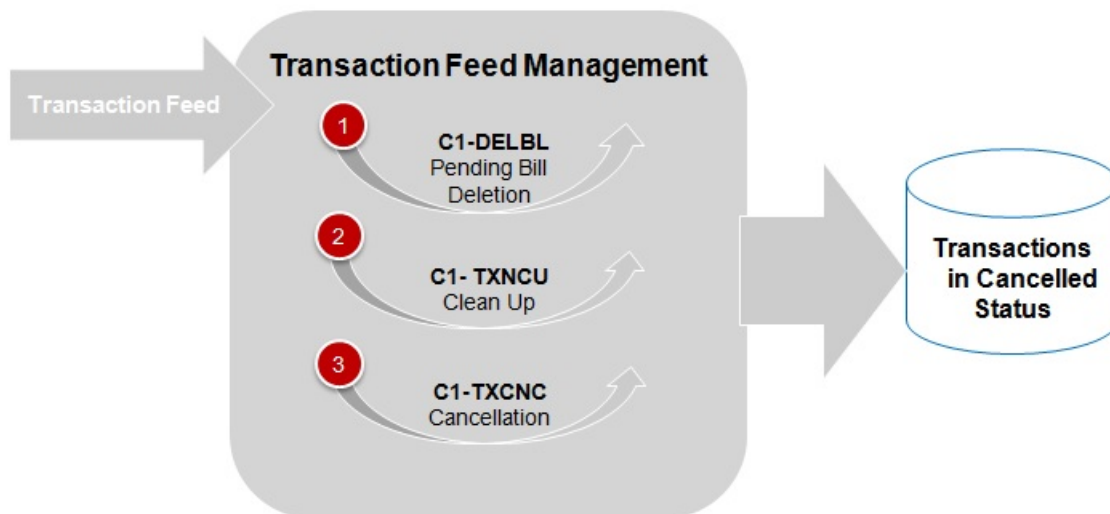

## Transaction Rollback

---

In the transaction aggregation process, an error occurs when:

- Transaction validation fails.
- Transaction does not satisfy any rule invoked through the rule type.
- Effective pricing is not available for one or more price items to which a transaction is mapped.
- SQIs are not defined for the price item — division combination.
- Transaction aggregation rule is not defined for the SQL.
- Exchange rate is not available during currency conversion.
- There is no contract available with the specified contract type on the transaction date or when the contract is inactive.
- There are multiple effective contracts of the same contract type (available on the transaction date) in **Active**, **Pending Stop**, or **Stop** status.
- The **Price Assignment Search** algorithm is not defined for the division.
- The parameter values are either not defined or invalid in the **Price Assignment Search** algorithm on the processing date.
- The period in which the transaction date falls is not defined in the aggregation schedule.
- Price Item parameters specified in the output parameters are not effective for the price item on the processing date.
- Mandatory price item parameter which is effective on the processing date is not specified in the output parameter.
- Parameter value is not specified for all mandatory price item parameters which are effective on the processing date.

In such cases, the status of the transaction is changed to **Error**. You can configure the required setup and then execute the following batches once again in the specified order:

1. Flush All Caches (F1-FLUSH)
2. Refresh Pricing (C1-TXNRP)
3. Header Validation (C1-TXNHV)
4. Validate Transaction and Derive Price Item (C1-TXNIP)
5. Populate CI\_TXN\_DTL\_PRITM\_SUMMARY Table (C1-TXNPS)

**Note:** You must execute the **Populate CI\_TXN\_DTL\_PRITM\_SUMMARY Table (C1-TXNPS)** batch only when the **Use C1-TXNPS During Transaction Aggregation** option type in the **C1\_FM** feature configuration is set to **true**.

6. Price Item Pricing Verification (C1-TXNVP)
7. Update Status (C1-TXNEX)
8. Service Quantity Calculation (C1-TXNSQ)
9. Mark Completion (C1-TXNCM)
10. Clean Up (C1-TXNCU)

But, before you execute these batches, you need to rollback the transaction status to **Uploaded (UPLD)**. The system allows you to rollback transactions which are in the **Ignored (IGNR)** and **Error (EROR)** status. When you rollback a transaction, the corresponding transaction legs are deleted and the status of the transaction is changed to **Uploaded (UPLD)**. On rolling back a transaction leg whose effective pricing has the **Ignore Transaction** field set to **Yes** and the **Rating Criteria** field set to **Rate Transactions (RITX)**, the corresponding calculation lines are also deleted along with the transaction leg. If you rollback a partially disaggregated transaction which is in the **Error (EROR)** status, the transaction legs which are in the **Error (EROR)** status are only deleted and the status of the transaction is changed to **Uploaded (UPLD)**.

You need to execute the **Rollback (C1-TXNRB)** batch to rollback transactions which are in the **Ignored (IGNR)** and **Error (EROR)** status. You can specify the following parameters while executing this batch:

Parameter Name	Description	Mandatory (Yes or No)
Transaction Status	Used to indicate whether you want to rollback transactions which are in the <b>Ignored</b> or <b>Error</b> status. The valid values are: <ul style="list-style-type: none"> <li>• IGNR</li> <li>• EROR</li> </ul>	Yes
Transaction Header ID	Used when you want to rollback transactions which are received in a particular transaction feed.	No
Transaction Source	Used when you want to rollback transactions which are received from a particular transaction source.	No
Division	Used when you want to rollback transactions belonging to a particular division.	No
Rollback From Date	Used when you want to rollback transactions which were performed from a particular date onwards. <div style="border: 1px solid black; padding: 5px; margin-top: 10px;"> <p><b>Note:</b> You must specify the date in the YYYY-MM-DD format. The rollback from date cannot be later than the rollback to date.</p> </div>	No
Rollback To Date	Used when you want to rollback transactions which were performed till a particular date. <div style="border: 1px solid black; padding: 5px; margin-top: 10px;"> <p><b>Note:</b> You must specify the date in the YYYY-MM-DD format. The rollback to date cannot be earlier than the rollback from date.</p> </div>	No

Parameter Name	Description	Mandatory (Yes or No)
Chunk Size	Used to specify the number of transactions you want to execute in each work unit.	Yes
Maximum Batch Count	Used to specify the maximum number of transactions after which the data must be transferred to the database.	Yes
Thread Pool Name	Used to specify the thread pool on which you want to execute the batch.	No

**Note:**

If you want to undertake some preprocessing activities (such as cleaning data in any custom tables) during the rollback process, you need to attach a preprocessing algorithm on the **Transaction Feed Management Rollback Preprocessing** algorithm entity in the **Algorithms** tab of the **Division** screen. This algorithm is triggered when you execute the **Rollback (C1-TXNRB)** batch. Note that the system invokes the algorithm which is attached on the division to which the transaction belongs.

A sample preprocessing algorithm type named **C1\_ROBK\_PRPC** is shipped with the product. It does not have any business logic. If you want to undertake some preprocessing activities during the rollback process, you need to create custom algorithm type and attach the respective algorithm on the **TFM - Rollback Pre-Processing** algorithm spot of the respective division. You can refer to the **C1\_ROBK\_PRPC** algorithm type to understand the input parameters that must be passed to the custom algorithm type.

**Related Topics**

For more information on...	See...
Transaction Leg Status Transition	<a href="#">Transaction Leg Status Transition</a> on page 903

## Feed Status Transition

The following figure graphically indicates how a feed moves from one status to another during the transaction feed management process:

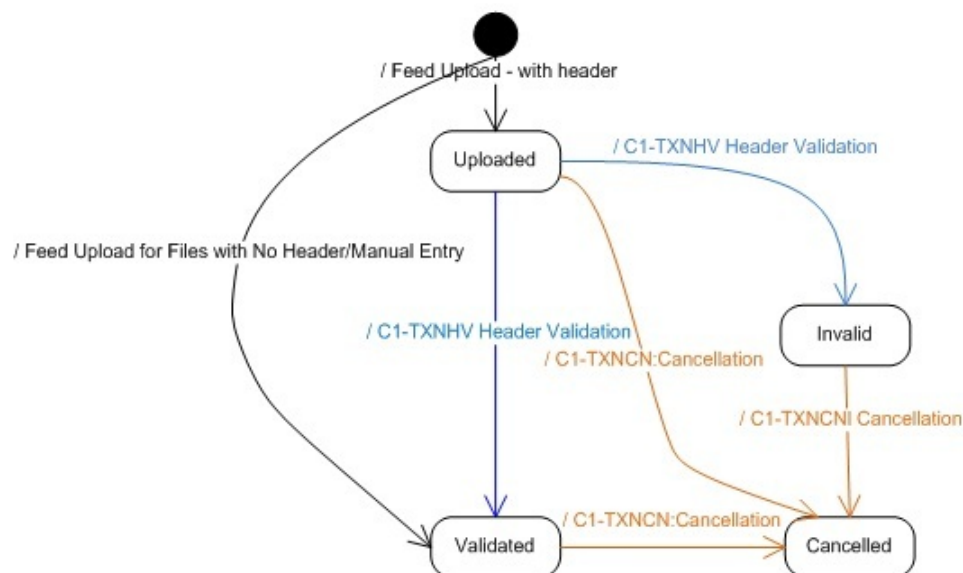

## Transaction Status Transition

### Aggregation

The following figure graphically indicates how a transaction moves from one status to another during the aggregation process:

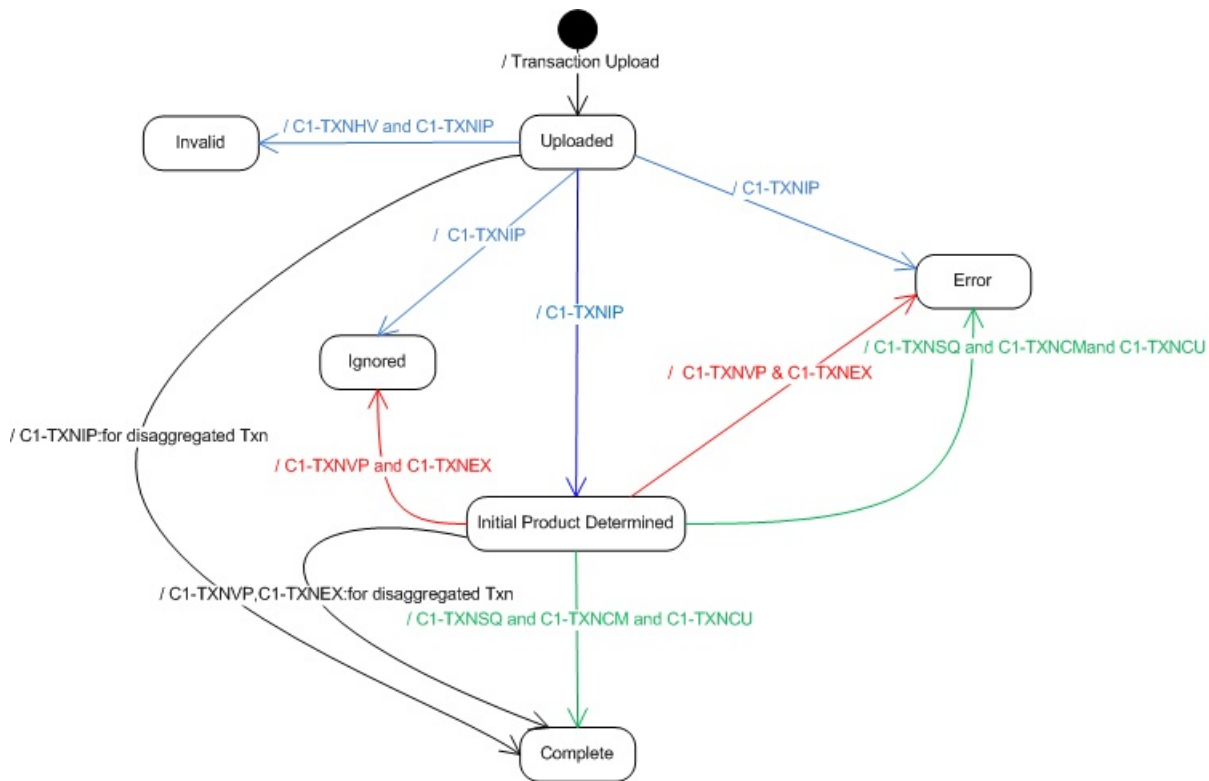

### Disaggregation, Rollback, and Cancellation

The following figure graphically indicates how a transaction moves from one status to another during the disaggregation, rollback, and cancellation processes:

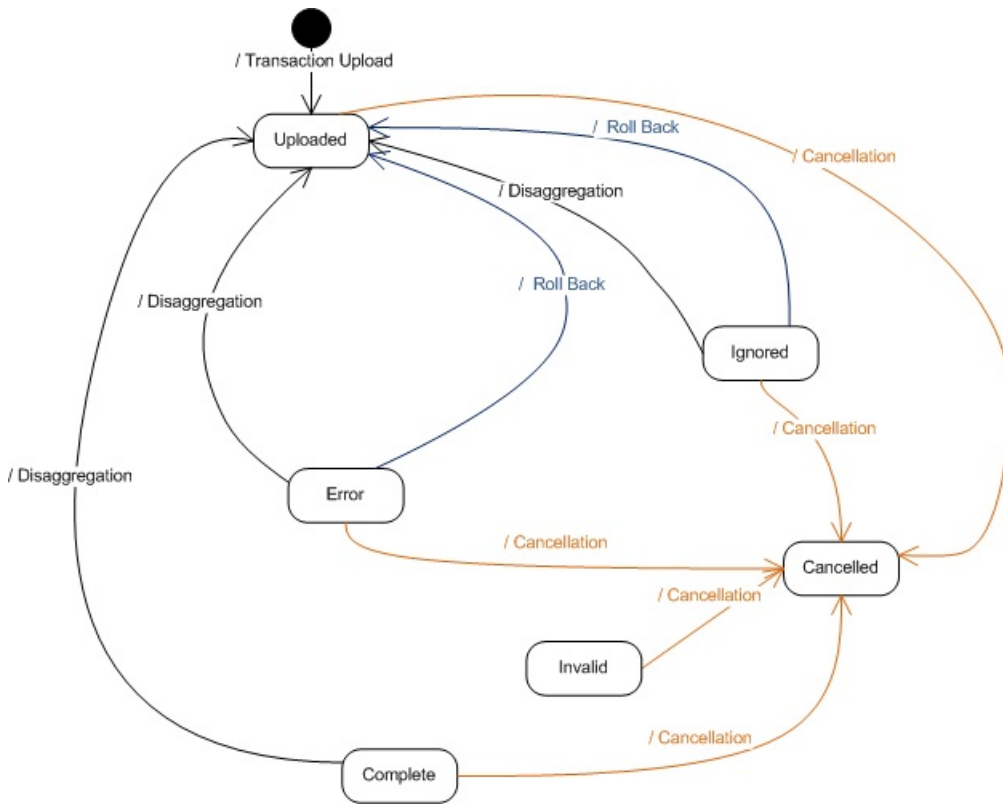

## Transaction Leg Status Transition

This section explains how a transaction leg moves from one status to another during the following sub-processes:

- Transaction Aggregation

**Note:** This is the aggregation process for transactions that are recently uploaded or reaggregated after being fully disaggregated.

- Transaction Rollback
- Transaction Cancellation
- Transaction Disaggregation
- Transaction Reaggregation

**Note:** This is the aggregation process for transactions that are reaggregated after being partially disaggregated.

### Transaction Aggregation

The following table indicates how a transaction leg moves from one status to another during the aggregation process:

Sr. No.	Batch	Event	Pre Event Transaction Status	Pre Event Transaction Leg Status	Post Event Transaction Status	Post Event Transaction Leg Status
1	C1-TXNIP	Transaction validation fails due to incomplete transaction data	UPLOADED	Not applicable as the transaction legs are not yet created	INVALID	Not applicable as the transaction legs are not yet created
2	C1-TXNIP	Transaction validation fails due to invalid or incorrect transaction data	UPLOADED	Not applicable as the transaction legs are not yet created	ERROR	Not applicable as the transaction legs are not yet created
3	C1-TXNIP	Transaction validation is successful but no product is derived	UPLOADED	Not applicable as the transaction legs are not yet created	ERROR	Not applicable as the transaction legs are not yet created
4	C1-TXNIP	Transaction validation is successful and product is derived	UPLOADED	Not applicable as the transaction legs are not yet created	INITIAL PRODUCT DETERMINED	INITIAL PRODUCT DETERMINED
5	C1-TXNIP	Transaction validation is successful and the transaction is ignored by the rule based on the transaction attributes	UPLOADED	Not applicable as the transaction legs are not yet created	IGNORED	Not applicable as the transaction legs are not yet created
6	C1-TXNVP and C1-TXNEX	Effective pricing is not found for any of the transaction legs	INITIAL PRODUCT DETERMINED	INITIAL PRODUCT DETERMINED	ERROR	ERROR
7	C1-TXNVP and C1-TXNEX	<b>Ignore Transaction</b> flag is set to <b>Y</b> in the effective pricing for one or more transaction legs but not for all transaction legs	INITIAL PRODUCT DETERMINED	INITIAL PRODUCT DETERMINED	INITIAL PRODUCT DETERMINED	IGNORED (when <b>Ignore Transaction</b> flag is set to <b>Y</b> in the effective pricing) INITIAL PRODUCT DETERMINED (when <b>Ignore Transaction</b> flag is set to <b>N</b> in the effective pricing)
8	C1-TXNVP and C1-TXNEX	<b>Ignore Transaction</b> flag is set to <b>Y</b> in the effective pricing for all transaction legs	INITIAL PRODUCT DETERMINED	INITIAL PRODUCT DETERMINED	IGNORED	IGNORED



Sr. No.	Batch	Event	Pre Event Transaction Status	Pre Event Transaction Leg Status	Post Event Transaction Status	Post Event Transaction Leg Status
9	C1-TXNVP and C1-TXNEX	<b>Ignore Transaction</b> flag is set to <b>N</b> in the effective pricing for all transaction legs	INITIAL PRODUCT DETERMINED	INITIAL PRODUCT DETERMINED	INITIAL PRODUCT DETERMINED	INITIAL PRODUCT DETERMINED
10	C1-TXNSQ and C1-TXNCM	SQIs are not defined for the product — division combination, Transaction aggregation rule is not defined for the SQI, or Exchange rate is not available during currency conversion	INITIAL PRODUCT DETERMINED	INITIAL PRODUCT DETERMINED	ERROR	ERROR
11	C1-TXNSQ and C1-TXNCM	Billable charges are created successfully for all transaction legs	INITIAL PRODUCT DETERMINED	INITIAL PRODUCT DETERMINED	COMPLETED	COMPLETED

### Transaction Rollback

The following table indicates how a transaction leg moves from one status to another during the rollback process:

Sr. No.	Batch	Event	Pre Event Transaction Status	Pre Event Transaction Leg Status	Post Event Transaction Status	Post Event Transaction Leg Status
1	C1-TXNRB	Transactions with the Error (EROR) status are rolled back	ERROR	ERROR	UPLOADED	Not applicable as the transaction legs are not yet created
2	C1-TXNRB	Transactions with the Ignored (IGNR) status are rolled back	IGNORED	IGNORED	UPLOADED	Not applicable as the transaction legs are not yet created

### Transaction Cancellation

The following table indicates how a transaction leg moves from one status to another during the cancellation process:

Sr. No.	Batch	Event	Pre Event Transaction Status	Pre Event Transaction Leg Status	Post Event Transaction Status	Post Event Transaction Leg Status
1	C1-TXCNC	Transactions in any status are cancelled	UPLOADED, INITIAL PRODUCT DETERMINED, ERROR, COMPLETED, INVALID, or IGNORED	INITIAL PRODUCT DETERMINED, ERROR, IGNORED, or COMPLETED	CANCELLED	CANCELLED

**Transaction Disaggregation**

The following table indicates how a transaction leg moves from one status to another during the disaggregation process:

<b>Sr. No.</b>	<b>Batch</b>	<b>Event</b>	<b>Pre Event Transaction Status</b>	<b>Pre Event Transaction Leg Status</b>	<b>Post Event Transaction Status</b>	<b>Post Event Transaction Leg Status</b>
1	C1-DISTG	Transactions in the COMPLETED, ERROR, or IGNORED status are disaggregated.	COMPLETED, ERROR, or IGNORED  <b>Note:</b> The transactions in the ERROR or IGNORED status must have legs for disaggregation.	COMPLETED, ERROR, or IGNORED	No change in the status	No change in the status
2	C1-DISTG	Transactions in the INVALID or CANCELLED status cannot be disaggregated. In addition, the newly uploaded transactions and fully disaggregated transactions which are in the UPLOADED status cannot be disaggregated.	CANCELLED, INVALID, or UPLOADED	Not applicable as the transactions will not have any legs in these statuses	No change in the status	Not applicable as the transactions will not have any legs in these statuses
3	C1-IDENT	Transactions in the COMPLETED, ERROR, or IGNORED status are disaggregated.	COMPLETED, ERROR, or IGNORED  <b>Note:</b> The transactions in the ERROR or IGNORED status must have legs for disaggregation.	COMPLETED, ERROR, or IGNORED	No change in the status	No change in the status

Sr. No.	Batch	Event	Pre Event Transaction Status	Pre Event Transaction Leg Status	Post Event Transaction Status	Post Event Transaction Leg Status
4	C1-IDENT	Transaction has already been disaggregated and is in the UPLOADED status. The transaction legs which were not affected are moved in the staging table and the transaction legs which were affected are deleted. Now, if the effective pricing is changed for the account to which the transaction leg in the staging table is mapped, then that transaction leg must be disaggregated. Thus, disaggregation is done even though the transaction is in the UPLOADED status.	UPLOADED	UPLOADED	No change in the status	No change in the status
5	C1-PDTXN	Transactions in the COMPLETED, ERROR, or IGNORED status are disaggregated.	COMPLETED, ERROR, or IGNORED <b>Note:</b> The transactions in the ERROR or IGNORED status must have legs for disaggregation.	COMPLETED, ERROR, or IGNORED	UPLOADED	Transaction legs which are affected during disaggregation are deleted and the other legs which are not affected are moved to the staging table.

### **Transaction Reaggregation**

The following table indicates how a transaction leg moves from one status to another during the reaggregation process:

Sr. No.	Batch	Event	Transaction Status Before Disaggregation	Transaction Leg Status Before Disaggregation	Transaction Status After Reaggregation	Transaction Leg Status After Reaggregation
1	C1-TXNIP	Transaction in the COMPLETED status was disaggregated. It had four transaction legs – two in the COMPLETED status and other two in the IGNORED status. A transaction leg in the COMPLETED status was disaggregated due to change in the business rule (i.e. <b>IGNORE_SW</b> is set to <b>Y</b> ).	COMPLETED	COMPLETED, IGNORED	COMPLETED	Derived Leg: IGNORED Existing Legs: COMPLETED and IGNORED
2	C1-TXNIP	Transaction in the COMPLETED status was disaggregated. It had one transaction leg in the COMPLETED status and all other transaction legs in the IGNORED status. The leg in the COMPLETED status was disaggregated due to change in the business rule (i.e. <b>IGNORE_SW</b> is set to <b>Y</b> ).	COMPLETED	COMPLETED, IGNORED	IGNORED	Derived Leg: IGNORED Existing Legs: IGNORED

Sr. No.	Batch	Event	Transaction Status Before Disaggregation	Transaction Leg Status Before Disaggregation	Transaction Status After Reaggregation	Transaction Leg Status After Reaggregation
3	C1-TXNIP	Transaction in the COMPLETED status was disaggregated. All the transaction legs were in the COMPLETED status. One of the transaction legs in the COMPLETED status was disaggregated. During reaggregation, no product was derived for this transaction leg.	COMPLETED	COMPLETED	ERROR	Derived Leg: No new transaction leg was created Existing Legs: COMPLETED
4	C1-TXNIP	Transaction in the ERROR status was disaggregated. It had no transaction legs. During reaggregation, no product was derived for the transaction.	ERROR	No Transaction Legs Exist	ERROR	Derived Leg: No new transaction leg was created Existing Legs: None
5	C1-TXNIP	Transaction in the ERROR status was disaggregated. It had no transaction legs. During reaggregation, a product was derived for the transaction.	ERROR	No Transaction Legs Exist	INITIAL PRODUCT DETERMINED	Derived Leg: INITIAL PRODUCT DETERMINED Existing Legs: None

Sr. No.	Batch	Event	Transaction Status Before Disaggregation	Transaction Leg Status Before Disaggregation	Transaction Status After Reaggregation	Transaction Leg Status After Reaggregation
6	C1-TXNVP and C1-TXNEX	Transaction in the COMPLETED status was disaggregated. It had four transaction legs – two in the COMPLETED status and other two in the IGNORED status. A transaction leg in the COMPLETED status was disaggregated. During reaggregation, the effective pricing was not found for the transaction leg.	COMPLETED	COMPLETED, IGNORED	ERROR	Derived Leg: ERROR Existing Legs: COMPLETED and IGNORED
7	C1-TXNVP and C1-TXNEX	Transaction in the ERROR status was disaggregated. It had no transaction legs. During reaggregation, the effective pricing is found for the transaction legs.	ERROR	No Transaction Legs Exist	INITIAL PRODUCT DETERMINED	Derived Legs: INITIAL PRODUCT DETERMINED Existing Legs: None
8	C1-TXNVP and C1-TXNEX	Transaction in the COMPLETED status was disaggregated. It had four transaction legs – two in the COMPLETED status and other two in the IGNORED status. A transaction leg in the COMPLETED status was disaggregated due to change in the effective pricing (i.e. <b>Ignore Transaction</b> flag is set to <b>Y</b> ).	COMPLETED	COMPLETED, IGNORED	COMPLETED	Derived Leg: IGNORED Existing Legs: COMPLETED and IGNORED

Sr. No.	Batch	Event	Transaction Status Before Disaggregation	Transaction Leg Status Before Disaggregation	Transaction Status After Reaggregation	Transaction Leg Status After Reaggregation
9	C1-TXNVP and C1-TXNEX	Transaction in the COMPLETED status was disaggregated. It had one transaction leg in the COMPLETED status and all other transaction legs in the IGNORED status. The leg in the COMPLETED status was disaggregated due to change in the effective pricing (i.e. <b>Ignore Transaction</b> flag is set to <b>Y</b> ).	COMPLETED	COMPLETED, IGNORED	IGNORED	Derived Leg: IGNORED Existing Legs: IGNORED
10	C1-TXNSQ and C1-TXNCM	While reaggregating transaction legs, SQIs are not defined for the product — division combination, Transaction aggregation rule is not defined for the SQI, or Exchange rate is not available during currency conversion.	COMPLETED, ERROR, IGNORED <b>Note:</b> There must be no legs for the transaction in the IGNORED status.	COMPLETED, ERROR	ERROR	Derived Legs: ERROR Existing Legs: No change in the status
11	C1-TXNSQ and C1-TXNCM	Billable charges are created successfully for all transaction legs which were earlier disaggregated and now reaggregated.	COMPLETED, ERROR, IGNORED <b>Note:</b> There must be no legs for the transaction in the IGNORED status.	COMPLETED, ERROR	COMPLETED	Derived Leg: COMPLETED Existing Legs: No change in the status

## Transaction Data File

You can upload a transaction data file in the following formats:

- Comma Separated Values
- JavaScript Object Notation
- Fixed Position
- Pipe Separated Values
- Tilde Separated Values
- Extensible Markup Language

Before uploading a transaction data file, you need to ensure that it contains the following:

- **File Header** - Every file must have one header record. It should contain the following details:

Header Data	Description	Mandatory (Yes or No)
Transaction Source	Used to specify the source from where the transactions are received.	Yes
Header Date (YYYYMMDD)	Used to specify the header date.	Yes
Transaction Header ID	Used to specify the external transaction header ID.	Yes
File Name	Used to specify the file name.	Yes
Number of Transactions	Used to specify the total number of transaction records in the file.	Yes
Total Transaction Volume	Used to specify the total transaction volume.	Yes
Total Transaction Amount	Used to specify the total transaction amount.	Yes

- **Transaction Record** - Every file must have one or more transaction records. It should contain the following details:

Record Data	Description	Mandatory (Yes or No)
Transaction Record Type	Used to specify the record type of the transaction.	Yes
Transaction Source	Used to specify the source from where the transaction is received.	Yes
Transaction Date (YYYYMMDD)	Used to specify the date when the transaction was performed.	Yes
External Reference Number	Used to specify the external reference number of the transaction.	Yes
Customer Reference Number	Used to indicate the customer who has performed the transaction.	No
Division	Used to specify the division to which the transaction belongs.	Yes
Transaction Volume	Used to specify the transaction volume.	Yes
Transaction Amount	Used to specify the transaction amount.	Yes



Record Data	Description	Mandatory (Yes or No)
Transaction Currency	Used to specify the currency in which the transaction was performed.  <b>Note:</b> If you specify a currency other than the pricing currency, the system will do the currency conversion when the appropriate exchange rate is available in the system.	Yes
Credit/Debit Indicator	Used to indicate whether the transaction is a debit or a credit transaction. The valid values are: <ul style="list-style-type: none"> <li>• Plus (+)</li> <li>• Minus (-)</li> </ul>	Yes
Account Identifier Type	Used to indicate the account identifier type.	Yes
Account Identifier	Used to indicate the account for which the transaction was performed.	Yes
UDF_NUM_1, UDF_NUM_2, UDF_NUM_3, ..., UDF_NUM_20	Used to specify additional information about the transaction.	No
UDF_AMT_1, UDF_AMT_2, UDF_AMT_3, ..., UDF_AMT_10	Used to specify additional transaction amount.	Yes (Conditional)  <b>Note:</b> The UDF_AMT_N is required when the corresponding UDF_CCY_N is specified.
UDF_CCY_1, UDF_CCY_2, UDF_CCY_3, ....., UDF_CCY_10	Used to specify additional transaction currency.  <b>Note:</b> If you specify a currency other than the pricing currency, the system will do the currency conversion when the appropriate exchange rate is available in the system.	Yes (Conditional)  <b>Note:</b> The UDF_CCY_N is required when the corresponding UDF_AMT_N is specified.
UDF_DTTM_1, UDF_DTTM_2, ....., UDF_DTTM_5	Used to specify additional information about the transaction.	No
UDF_CHAR_1, UDF_CHAR_2, UDF_CHAR_3, ..., UDF_CHAR_50	Used to specify additional information about the transaction.  <b>Note:</b> If the data in these columns will be used for price item parameter mapping, you must not use the equal to (=) and tilde (~) symbols in these columns.	No

## Error List

The following table lists the errors that may occur while executing various batches in the transaction feed management process. It also indicates how you can resolve these errors.

Batch Name	Message Number	Error Message	Message Category	Possible Issues
C1-TXNHV	102	{Checksum Validation Required} field invalid.	11001	The possible issues could be: <ul style="list-style-type: none"> <li>The value other than 'Y', 'y', 'N' or 'n' is specified for the <b>Checksum Validation Required</b> parameter.</li> </ul>
C1-TXNHV	102	{Duplicate Check Required} field invalid.	11001	The possible issues could be: <ul style="list-style-type: none"> <li>The value other than 'Y', 'y', 'N' or 'n' is specified for the <b>Duplicate Check Required</b> parameter.</li> </ul>
C1-TXNHV	1314	The Transaction Source is mandatory.	17000	The possible issues could be: <ul style="list-style-type: none"> <li>The data is not available in the <b>Transaction Source</b> column.</li> </ul>
C1-TXNHV	1332	Sum of transaction records in the header does not match the total number of records in the file.	17000	The possible issues could be: <ul style="list-style-type: none"> <li>Inappropriate file is uploaded in the system.</li> </ul>
C1-TXNHV	1333	Sum of transaction volume in the header does not match the total transaction volume in the file.	17000	The possible issues could be: <ul style="list-style-type: none"> <li>Inappropriate file is uploaded in the system.</li> </ul>
C1-TXNHV	1334	Sum of transaction amount in the header does not match the total transaction amount in the file.	17000	The possible issues could be: <ul style="list-style-type: none"> <li>Inappropriate file is uploaded in the system.</li> </ul>
C1-TXNHV	1338	The Transaction Header ID already exists in the system. Please enter unique header ID.	17000	The possible issues could be: <ul style="list-style-type: none"> <li>The same file is uploaded multiple times in the system.</li> </ul>
C1-TXNHV	1341	Exception occurred during the transaction header validation.	17000	The possible issues could be: <ul style="list-style-type: none"> <li>The data is not available in the required format.</li> </ul>
C1-TXNHV	1421	Transaction records does not exist in the file. Please check.	17000	The possible issues could be: <ul style="list-style-type: none"> <li>Inappropriate file is uploaded in the system.</li> </ul>

Batch Name	Message Number	Error Message	Message Category	Possible Issues
C1-TXNHV	1422	Sum of transaction records in the header cannot be zero. Please enter valid data in the header.	17000	The possible issues could be: <ul style="list-style-type: none"> <li>The value available in the <b>Number of Transactions</b> column is less than or equal to zero.</li> </ul>
C1-TXNHV	1423	Sum of transaction volume in the header cannot be zero. Please enter valid data in the header.	17000	The possible issues could be: <ul style="list-style-type: none"> <li>The value available in the <b>Total Transaction Volume</b> column is less than or equal to zero.</li> </ul>
C1-TXNHV	1663	Transaction Header External Id is missing.	17000	The possible issues could be: <ul style="list-style-type: none"> <li>The data is not available in the <b>Transaction Header ID</b> column.</li> </ul>
C1-TXNHV	1664	Header Transaction Amount should be greater than 0.	17000	The possible issues could be: <ul style="list-style-type: none"> <li>The value available in the <b>Total Transaction Amount</b> column is less than or equal to zero.</li> </ul>
C1-TXNIP	102	{Chunk Size} field invalid	11001	The possible issues could be: <ul style="list-style-type: none"> <li>The value specified for the <b>Chunk Size</b> parameter is less than or equal to one.</li> </ul>
C1-TXNIP	102	{ Maximum Batch Size } field invalid	11001	The possible issues could be: <ul style="list-style-type: none"> <li>The value specified for the <b>Maximum Batch Count</b> parameter is greater than the value specified for the <b>Chunk Size</b> parameter.</li> </ul>
C1-TXNIP	106	Value { Given Transaction Header Id } too long for field { transactionHeaderId }. Maximum length: 14. Found: { Length of given Transaction Header Id}	11001	The possible issues could be: <ul style="list-style-type: none"> <li>The value specified for the <b>Transaction Header ID</b> parameter exceeds the maximum length of 14 characters.</li> </ul>
C1-TXNIP	106	Value { Given Transaction Source Code } too long for field { transactionSource }. Maximum length: 30. Found: { Length of given Transaction Source Code}	11001	The possible issues could be: <ul style="list-style-type: none"> <li>The value specified for the <b>Transaction Source</b> parameter exceeds the maximum length of 30 characters.</li> </ul>
C1-TXNIP	106	Value { Given Transaction Division } too long for field { division }. Maximum length: 5 Found: { Length of given Transaction Division}	11001	The possible issues could be: <ul style="list-style-type: none"> <li>The value specified for the <b>Division</b> parameter exceeds the maximum length of 5 characters.</li> </ul>

Batch Name	Message Number	Error Message	Message Category	Possible Issues
C1-TXNIP	1301	The account with the specified identifier does not exist in the system. Enter a valid identifier.	17000	The possible issues could be: <ul style="list-style-type: none"> <li>The account with the specified account identifier is not found in the system.</li> </ul>
C1-TXNIP	1302	UDF_CURRENCY_1 is mandatory when UDF_AMT_1 is non-zero. Enter a valid currency code.	17000	The possible issues could be: <ul style="list-style-type: none"> <li>The currency is not available in the <b>UDF_CURRENCY_CD_1</b> column of the <b>CI_TXN_DETAIL</b> table.</li> </ul>
C1-TXNIP	1303	UDF_AMT_1 is mandatory when UDF_CURRENCY_1 is specified. Enter the amount.	17000	The possible issues could be: <ul style="list-style-type: none"> <li>The amount is not available in the <b>UDF_AMT_1</b> column of the <b>CI_TXN_DETAIL</b> table.</li> </ul>
C1-TXNIP	1304	UDF_CURRENCY_2 is mandatory when UDF_AMT_2 is non-zero. Enter a valid currency code.	17000	The possible issues could be: <ul style="list-style-type: none"> <li>The currency is not available in the <b>UDF_CURRENCY_CD_2</b> column of the <b>CI_TXN_DETAIL</b> table.</li> </ul>
C1-TXNIP	1305	UDF_AMT_2 is mandatory when UDF_CURRENCY_2 is specified. Enter the amount.	17000	The possible issues could be: <ul style="list-style-type: none"> <li>The amount is not available in the <b>UDF_AMT_2</b> column of the <b>CI_TXN_DETAIL</b> table.</li> </ul>
C1-TXNIP	1306	UDF_CURRENCY_3 is mandatory when UDF_AMT_3 is non-zero. Enter a valid currency code.	17000	The possible issues could be: <ul style="list-style-type: none"> <li>The currency is not available in the <b>UDF_CURRENCY_CD_3</b> column of the <b>CI_TXN_DETAIL</b> table.</li> </ul>
C1-TXNIP	1307	UDF_AMT_3 is mandatory when UDF_CURRENCY_3 is specified. Enter the amount.	17000	The possible issues could be: <ul style="list-style-type: none"> <li>The amount is not available in the <b>UDF_AMT_3</b> column of the <b>CI_TXN_DETAIL</b> table.</li> </ul>
C1-TXNIP	1308	UDF_CURRENCY_4 is mandatory when UDF_AMT_4 is non-zero. Enter a valid currency code.	17000	The possible issues could be: <ul style="list-style-type: none"> <li>The currency is not available in the <b>UDF_CURRENCY_CD_4</b> column of the <b>CI_TXN_DETAIL</b> table.</li> </ul>
C1-TXNIP	1309	UDF_AMT_4 is mandatory when UDF_CURRENCY_4 is specified. Enter the amount.	17000	The possible issues could be: <ul style="list-style-type: none"> <li>The amount is not available in the <b>UDF_AMT_4</b> column of the <b>CI_TXN_DETAIL</b> table.</li> </ul>
C1-TXNIP	1310	UDF_CURRENCY_5 is mandatory when UDF_AMT_5 is non-zero. Enter a valid currency code.	17000	The possible issues could be: <ul style="list-style-type: none"> <li>The currency is not available in the <b>UDF_CURRENCY_CD_5</b> column of the <b>CI_TXN_DETAIL</b> table.</li> </ul>

Batch Name	Message Number	Error Message	Message Category	Possible Issues
C1-TXNIP	1311	UDF_AMT_5 is mandatory when UDF_CURRENCY_5 is specified. Enter the amount.	17000	The possible issues could be: <ul style="list-style-type: none"> <li>The amount is not available in the <b>UDF_AMT_5</b> column of the <b>CI_TXN_DETAIL</b> table.</li> </ul>
C1-TXNIP	1312	UDF_CURRENCY_6 is mandatory when UDF_AMT_6 is non-zero. Enter a valid currency code.	17000	The possible issues could be: <ul style="list-style-type: none"> <li>The currency is not available in the <b>UDF_CURRENCY_CD_6</b> column of the <b>CI_TXN_DETAIL</b> table.</li> </ul>
C1-TXNIP	1313	UDF_AMT_6 is mandatory when UDF_CURRENCY_6 is specified. Enter the amount.	17000	The possible issues could be: <ul style="list-style-type: none"> <li>The amount is not available in the <b>UDF_AMT_6</b> column of the <b>CI_TXN_DETAIL</b> table.</li> </ul>
C1-TXNIP	1314	UDF_CURRENCY_7 is mandatory when UDF_AMT_7 is non-zero. Enter a valid currency code.	17000	The possible issues could be: <ul style="list-style-type: none"> <li>The currency is not available in the <b>UDF_CURRENCY_CD_7</b> column of the <b>CI_TXN_DETAIL</b> table.</li> </ul>
C1-TXNIP	1315	UDF_AMT_7 is mandatory when UDF_CURRENCY_7 is specified. Enter the amount.	17000	The possible issues could be: <ul style="list-style-type: none"> <li>The amount is not available in the <b>UDF_AMT_7</b> column of the <b>CI_TXN_DETAIL</b> table.</li> </ul>
C1-TXNIP	1316	UDF_CURRENCY_8 is mandatory when UDF_AMT_8 is non-zero. Enter a valid currency code.	17000	The possible issues could be: <ul style="list-style-type: none"> <li>The currency is not available in the <b>UDF_CURRENCY_CD_8</b> column of the <b>CI_TXN_DETAIL</b> table.</li> </ul>
C1-TXNIP	1317	UDF_AMT_8 is mandatory when UDF_CURRENCY_8 is specified. Enter the amount.	17000	The possible issues could be: <ul style="list-style-type: none"> <li>The amount is not available in the <b>UDF_AMT_8</b> column of the <b>CI_TXN_DETAIL</b> table.</li> </ul>
C1-TXNIP	1318	UDF_CURRENCY_9 is mandatory when UDF_AMT_9 is non-zero. Enter a valid currency code.	17000	The possible issues could be: <ul style="list-style-type: none"> <li>The currency is not available in the <b>UDF_CURRENCY_CD_9</b> column of the <b>CI_TXN_DETAIL</b> table.</li> </ul>
C1-TXNIP	1319	UDF_AMT_9 is mandatory when UDF_CURRENCY_9 is specified. Enter the amount.	17000	The possible issues could be: <ul style="list-style-type: none"> <li>The amount is not available in the <b>UDF_AMT_9</b> column of the <b>CI_TXN_DETAIL</b> table.</li> </ul>

Batch Name	Message Number	Error Message	Message Category	Possible Issues
C1-TXNIP	1320	UDF_CURRENCY_10 is mandatory when UDF_AMT_10 is non-zero. Enter a valid currency code.	17000	The possible issues could be: <ul style="list-style-type: none"> <li>The currency is not available in the <b>UDF_CURRENCY_CD_10</b> column of the <b>CI_TXN_DETAIL</b> table.</li> </ul>
C1-TXNIP	1321	UDF_AMT_10 is mandatory when UDF_CURRENCY_10 is specified. Enter the amount.	17000	The possible issues could be: <ul style="list-style-type: none"> <li>The amount is not available in the <b>UDF_AMT_10</b> column of the <b>CI_TXN_DETAIL</b> table.</li> </ul>
C1-TXNIP	1347	Could not derive a price item from the rules engine.	17000	The possible issues could be: <ul style="list-style-type: none"> <li>There is some technical issue while executing the rule or while processing the rule output.</li> <li>No rules are effective on the processing date.</li> <li>The rule type is not defined for the transaction source and transaction record type combination in the system.</li> </ul>
C1-TXNIP	1349	Division is invalid. Please enter a valid division for the transaction.	17000	The possible issues could be: <ul style="list-style-type: none"> <li>Division (to which the transaction belongs) is not defined in the system.</li> </ul>
C1-TXNIP	1351	Transaction Currency is invalid. Please enter a valid currency code.	17000	The possible issues could be: <ul style="list-style-type: none"> <li>The currency in which the transaction was performed is not available in the <b>Transaction Currency</b> column.</li> <li>Currency is not defined in the system.</li> </ul>
C1-TXNIP	1362	UDF Currency 1 is invalid. Please enter a valid currency code.	17000	The possible issues could be: <ul style="list-style-type: none"> <li>Currency is not defined in the system.</li> </ul>
C1-TXNIP	1363	UDF Currency 2 is invalid. Please enter a valid currency code.	17000	The possible issues could be: <ul style="list-style-type: none"> <li>Currency is not defined in the system.</li> </ul>
C1-TXNIP	1364	UDF Currency 3 is invalid. Please enter a valid currency code.	17000	The possible issues could be: <ul style="list-style-type: none"> <li>Currency is not defined in the system.</li> </ul>

Batch Name	Message Number	Error Message	Message Category	Possible Issues
C1-TXNIP	1365	UDF Currency 4 is invalid. Please enter a valid currency code.	17000	The possible issues could be: <ul style="list-style-type: none"> <li>Currency is not defined in the system.</li> </ul>
C1-TXNIP	1366	UDF Currency 5 is invalid. Please enter a valid currency code.	17000	The possible issues could be: <ul style="list-style-type: none"> <li>Currency is not defined in the system.</li> </ul>
C1-TXNIP	1377	Transaction currency is mandatory when transaction amount is non-zero. Enter a valid currency code.	17000	The possible issues could be: <ul style="list-style-type: none"> <li>The currency is not available in the <b>Transaction Currency</b> column.</li> </ul>
C1-TXNIP	1378	Transaction amount is mandatory when transaction currency is specified. Enter the amount.	17000	The possible issues could be: <ul style="list-style-type: none"> <li>The amount is not available in the <b>Transaction Amount</b> column.</li> </ul>
C1-TXNIP	1379	The user does not exist in the system. Please enter a valid user ID.	17000	The possible issues could be: <ul style="list-style-type: none"> <li>The user is not defined in the system.</li> </ul>
C1-TXNIP	1380	The value entered in the Credit/Debit Indicator column is incorrect. Enter either "+" or "-".	17000	The possible issues could be: <ul style="list-style-type: none"> <li>The value other than '+' or '-' is available in the <b>HOW_TO_USE_TXN_FLG</b> column of the <b>CI_TXN_DETAIL</b> table.</li> </ul>
C1-TXNIP	1381	The value entered in the Manual Switch field is incorrect. Enter either "Y" or "N".	17000	The possible issues could be: <ul style="list-style-type: none"> <li>The value other than 'Y' or 'N' is available in the <b>MANUAL_SW</b> column of the <b>CI_TXN_DETAIL</b> table.</li> </ul>
C1-TXNIP	1556	{Maximum Batch Size} field should be greater than zero	17000	The possible issues could be: <ul style="list-style-type: none"> <li>The value specified for the <b>Maximum Batch Count</b> parameter is less than or equal to zero.</li> </ul>
C1-TXNIP	1636	Invalid batch run [%1] for [%2] division(s). %3  <div style="border: 1px solid black; padding: 5px; background-color: #f0f0f0;"> <p><b>Note:</b>  [%1] stands for batch code;  [%2] stands for division;  [%3] stands for expected batch code</p> </div>	17000	The possible issues could be: <ul style="list-style-type: none"> <li>You are trying to execute the C1-TXNVP, C1-TXNEX, C1-TXNSQ, C1-TXNCM or C1-TXNCU batch instead of the C1-TXNIP batch (which is first mandatory batch in the transaction aggregation cycle).</li> </ul>

Batch Name	Message Number	Error Message	Message Category	Possible Issues
C1-TXNIP	1637	Batch [%1] is already executed for [%2] division(s). Please complete pending batch runs before starting new cycle for [%3] division(s).  <b>Note:</b> [%1] stands for batch code; [%2] and [%3] stands for division	17000	The possible issues could be: <ul style="list-style-type: none"> <li>You are trying to execute this batch once again with the same division (for example, D1) after executing any other batch in the transaction aggregation cycle which is already initiated for D1.</li> </ul>
C1-TXNIP	1638	Transaction Feed Management cycle for individual division(s) is not yet complete. Please complete pending batch runs before starting new cycle for processing [ALL] divisions.	17000	The possible issues could be: <ul style="list-style-type: none"> <li>You are trying to execute this batch for all divisions before completing the transaction aggregation cycle which is initiated for a particular division.</li> </ul>
C1-TXNIP	1639	Transaction Feed Management cycle for [ALL] divisions is not yet complete. Please complete pending batch runs before starting new cycle for individual division [%1].  <b>Note:</b> [%1] stands for division	17000	The possible issues could be: <ul style="list-style-type: none"> <li>You are trying to execute this batch for a particular division before completing the transaction aggregation cycle which is initiated for all divisions.</li> </ul>
C1-TXNIP	1646	Value for mandatory parameter is missing.	17000	The possible issues could be: <ul style="list-style-type: none"> <li>No value is defined for the mandatory price item parameter in the rule.</li> </ul>
C1-TXNIP	1647	Mandatory parameter is missing.	17000	The possible issues could be: <ul style="list-style-type: none"> <li>The mandatory price item parameter is not defined as the output parameter in the rule.</li> </ul>
C1-TXNIP	1648	Account Number derived by the rule is invalid.	17000	The possible issues could be: <ul style="list-style-type: none"> <li>No value is defined for either <b>Account Identifier (ACCT_NOX_Val)</b> or <b>Account Identifier Column Name (ACCT_NOX_Col)</b> output parameter in the rule.</li> </ul>



Batch Name	Message Number	Error Message	Message Category	Possible Issues
C1-TXNIP	1649	Account Number type code derived by the rule is invalid.	17000	The possible issues could be: <ul style="list-style-type: none"> <li>No value is defined for either <b>Account Identifier Type (ACCT_NO_TYPEX_Val)</b> or <b>Account Identifier Type Column Name (ACCT_NO_TYPEX_Col)</b> output parameter in the rule.</li> </ul>
C1-TXNIP	1650	Division derived by the rule is invalid.	17000	The possible issues could be: <ul style="list-style-type: none"> <li>No value is defined for either <b>Account Division (DIVISIONX_VAL)</b> or <b>Account Division Column Name (DIVISIONX_COL)</b> output parameter in the rule.</li> </ul>
C1-TXNIP	1651	Not able to derive account ID.	17000	The possible issues could be: <ul style="list-style-type: none"> <li>The account with the specified account identifier type, account identifier, and division is not found in the system.</li> </ul>
C1-TXNIP	1652	Product derived by the rule is invalid.	17000	The possible issues could be: <ul style="list-style-type: none"> <li>No value is defined for either <b>Product Name (PRODUCTX_Y_Val)</b> or <b>Product Column Name (PRODUCTX_Y_Col)</b> output parameter in the rule.</li> </ul>
C1-TXNIP	1653	Length of the derived product is greater than 10.	17000	The possible issues could be: <ul style="list-style-type: none"> <li>The value specified for the <b>Product Name (PRODUCTX_Y_Val)</b> or <b>Product Column Name (PRODUCTX_Y_Col)</b> output parameter in the rule exceeds the maximum length of 10 characters.</li> </ul>
C1-TXNIP	1654	Length of the derived variance parameter is greater than 8.	17000	The possible issues could be: <ul style="list-style-type: none"> <li>The value specified for the <b>TOU (TOUX_Y_Val)</b> or <b>TOU Column Name (TOUX_Y_Col)</b> output parameter in the rule exceeds the maximum length of 8 characters.</li> </ul>

Batch Name	Message Number	Error Message	Message Category	Possible Issues
C1-TXNIP	1656	Length of the product parameter value derived by the rule is greater than 254.	17000	The possible issues could be: <ul style="list-style-type: none"> <li>The value specified for the <b>Parameter Value (PVLX_Y_Z_VAL)</b> or <b>Parameter Value Column Name (PVLX_Y_Z_COL)</b> output parameter in the rule exceeds the maximum length of 254 characters.</li> </ul>
C1-TXNIP	1657	Length of the product parameter code derived by the rule is greater than 30.	17000	The possible issues could be: <ul style="list-style-type: none"> <li>The value specified for the <b>Parameter Code (PCDX_Y_Z_VAL)</b> output parameter in the rule exceeds the maximum length of 30 characters.</li> </ul>
C1-TXNIP	2002	Transaction is in EROR due to one or more reasons.	17000	The possible issues could be: <ul style="list-style-type: none"> <li>There might be one or more reasons why the status of the transaction is set to <b>Error (EROR)</b>.</li> </ul>
C1-TXNIP	2007	%1 cannot be blank. <b>Note:</b> [%1] stands for division	17000	The possible issues could be: <ul style="list-style-type: none"> <li>The division to which the transaction belongs is not available in the <b>Division</b> column.</li> </ul>
C1-TXNIP	2007	%1 cannot be blank. <b>Note:</b> [%1] stands for user ID	17000	The possible issues could be: <ul style="list-style-type: none"> <li>No data exists in the <b>USER_ID</b> column of the <b>CI_TXN_DETAIL</b> table when the <b>MANUAL_SW</b> column is set to <b>Y</b>.</li> </ul>
C1-TXNIP	2011	%1 is mandatory when %2 is non-zero. Enter a valid currency code. <b>Note:</b> [%1] stands for "Currency Code"; [%2] stands for "Transaction Amount"	17000	The possible issues could be: <ul style="list-style-type: none"> <li>The currency in which the transaction was performed is not available in the <b>CURRENCY_CD</b> column of the <b>CI_TXN_DETAIL</b> table.</li> </ul>

Batch Name	Message Number	Error Message	Message Category	Possible Issues
C1-TXNIP	2011	<p>%1 is mandatory when %2 is non-zero. Enter a valid currency code.</p> <div style="border: 1px solid black; padding: 5px;"> <p><b>Note:</b></p> <p>[%1] stands for “Amount 1 Currency Code”;</p> <p>[%2] stands for “Additional Amount 1”</p> </div>	17000	<p>The possible issues could be:</p> <ul style="list-style-type: none"> <li>The currency is not available in the <b>UDF_CURRENCY_CD_1</b> column of the <b>CI_TXN_DETAIL</b> table.</li> </ul>
C1-TXNIP	2011	<p>%1 is mandatory when %2 is non-zero. Enter a valid currency code.</p> <div style="border: 1px solid black; padding: 5px;"> <p><b>Note:</b></p> <p>[%1] stands for “Amount 2 Currency Code”;</p> <p>[%2] stands for “Additional Amount 2”</p> </div>	17000	<p>The possible issues could be:</p> <ul style="list-style-type: none"> <li>The currency is not available in the <b>UDF_CURRENCY_CD_2</b> column of the <b>CI_TXN_DETAIL</b> table.</li> </ul>
C1-TXNIP	2011	<p>%1 is mandatory when %2 is non-zero. Enter a valid currency code.</p> <div style="border: 1px solid black; padding: 5px;"> <p><b>Note:</b></p> <p>[%1] stands for “Amount 3 Currency Code”;</p> <p>[%2] stands for “Additional Amount 3”</p> </div>	17000	<p>The possible issues could be:</p> <ul style="list-style-type: none"> <li>The currency is not available in the <b>UDF_CURRENCY_CD_3</b> column of the <b>CI_TXN_DETAIL</b> table.</li> </ul>
C1-TXNIP	2011	<p>%1 is mandatory when %2 is non-zero. Enter a valid currency code.</p> <div style="border: 1px solid black; padding: 5px;"> <p><b>Note:</b></p> <p>[%1] stands for “Amount 4 Currency Code”;</p> <p>[%2] stands for “Additional Amount 4”</p> </div>	17000	<p>The possible issues could be:</p> <ul style="list-style-type: none"> <li>The currency is not available in the <b>UDF_CURRENCY_CD_4</b> column of the <b>CI_TXN_DETAIL</b> table.</li> </ul>

Batch Name	Message Number	Error Message	Message Category	Possible Issues
C1-TXNIP	2011	<p>%1 is mandatory when %2 is non-zero. Enter a valid currency code.</p> <div style="border: 1px solid black; padding: 5px;"> <p><b>Note:</b></p> <p>[%1] stands for “Amount 5 Currency Code”;</p> <p>[%2] stands for “Additional Amount 5”</p> </div>	17000	<p>The possible issues could be:</p> <ul style="list-style-type: none"> <li>The currency is not available in the <b>UDF_CURRENCY_CD_5</b> column of the <b>CI_TXN_DETAIL</b> table.</li> </ul>
C1-TXNIP	2011	<p>%1 is mandatory when %2 is non-zero. Enter a valid currency code.</p> <div style="border: 1px solid black; padding: 5px;"> <p><b>Note:</b></p> <p>[%1] stands for “Amount 6 Currency Code”;</p> <p>[%2] stands for “Additional Amount 6”</p> </div>	17000	<p>The possible issues could be:</p> <ul style="list-style-type: none"> <li>The currency is not available in the <b>UDF_CURRENCY_CD_6</b> column of the <b>CI_TXN_DETAIL</b> table.</li> </ul>
C1-TXNIP	2011	<p>%1 is mandatory when %2 is non-zero. Enter a valid currency code.</p> <div style="border: 1px solid black; padding: 5px;"> <p><b>Note:</b></p> <p>[%1] stands for “Amount 7 Currency Code”;</p> <p>[%2] stands for “Additional Amount 7”</p> </div>	17000	<p>The possible issues could be:</p> <ul style="list-style-type: none"> <li>The currency is not available in the <b>UDF_CURRENCY_CD_7</b> column of the <b>CI_TXN_DETAIL</b> table.</li> </ul>
C1-TXNIP	2011	<p>%1 is mandatory when %2 is non-zero. Enter a valid currency code.</p> <div style="border: 1px solid black; padding: 5px;"> <p><b>Note:</b></p> <p>[%1] stands for “Amount 8 Currency Code”;</p> <p>[%2] stands for “Additional Amount 8”</p> </div>	17000	<p>The possible issues could be:</p> <ul style="list-style-type: none"> <li>The currency is not available in the <b>UDF_CURRENCY_CD_8</b> column of the <b>CI_TXN_DETAIL</b> table.</li> </ul>

Batch Name	Message Number	Error Message	Message Category	Possible Issues
C1-TXNIP	2011	<p>%1 is mandatory when %2 is non-zero. Enter a valid currency code.</p> <div style="border: 1px solid black; padding: 5px;"> <p><b>Note:</b></p> <p>[%1] stands for “Amount 9 Currency Code”;</p> <p>[%2] stands for “Additional Amount 9”</p> </div>	17000	<p>The possible issues could be:</p> <ul style="list-style-type: none"> <li>The currency is not available in the <b>UDF_CURRENCY_CD_9</b> column of the <b>CI_TXN_DETAIL</b> table.</li> </ul>
C1-TXNIP	2011	<p>%1 is mandatory when %2 is non-zero. Enter a valid currency code.</p> <div style="border: 1px solid black; padding: 5px;"> <p><b>Note:</b></p> <p>[%1] stands for “Amount 10 Currency Code”;</p> <p>[%2] stands for “Additional Amount 10”</p> </div>	17000	<p>The possible issues could be:</p> <ul style="list-style-type: none"> <li>The currency is not available in the <b>UDF_CURRENCY_CD_10</b> column of the <b>CI_TXN_DETAIL</b> table.</li> </ul>
C1-TXNIP	2012	<p>%1 %2 is invalid. Please enter a valid currency code.</p> <div style="border: 1px solid black; padding: 5px;"> <p><b>Note:</b></p> <p>[%1] stands for “Currency Code”;</p> <p>[%2] stands for transaction currency</p> </div>	17000	<p>The possible issues could be:</p> <ul style="list-style-type: none"> <li>Currency is not defined in the system.</li> </ul>
C1-TXNIP	2012	<p>%1 %2 is invalid. Please enter a valid currency code.</p> <div style="border: 1px solid black; padding: 5px;"> <p><b>Note:</b></p> <p>[%1] stands for “Amount 1 Currency Code”;</p> <p>[%2] stands for UDF_CURRENCY_CD_1</p> </div>	17000	<p>The possible issues could be:</p> <ul style="list-style-type: none"> <li>Currency is not defined in the system.</li> </ul>

Batch Name	Message Number	Error Message	Message Category	Possible Issues
C1-TXNIP	2012	% 1 %2 is invalid. Please enter a valid currency code.  <b>Note:</b> [%1] stands for “Amount 2 Currency Code”; [%2] stands for UDF_CURRENCY_CD_2	17000	The possible issues could be: <ul style="list-style-type: none"> <li>• Currency is not defined in the system.</li> </ul>
C1-TXNIP	2012	% 1 %2 is invalid. Please enter a valid currency code.  <b>Note:</b> [%1] stands for “Amount 3 Currency Code”; [%2] stands for UDF_CURRENCY_CD_3	17000	The possible issues could be: <ul style="list-style-type: none"> <li>• Currency is not defined in the system.</li> </ul>
C1-TXNIP	2012	% 1 %2 is invalid. Please enter a valid currency code.  <b>Note:</b> [%1] stands for “Amount 4 Currency Code”; [%2] stands for UDF_CURRENCY_CD_4	17000	The possible issues could be: <ul style="list-style-type: none"> <li>• Currency is not defined in the system.</li> </ul>
C1-TXNIP	2012	% 1 %2 is invalid. Please enter a valid currency code.  <b>Note:</b> [%1] stands for “Amount 5 Currency Code”; [%2] stands for UDF_CURRENCY_CD_5	17000	The possible issues could be: <ul style="list-style-type: none"> <li>• Currency is not defined in the system.</li> </ul>
C1-TXNIP	2012	% 1 %2 is invalid. Please enter a valid currency code.  <b>Note:</b> [%1] stands for “Amount 6 Currency Code”; [%2] stands for UDF_CURRENCY_CD_6	17000	The possible issues could be: <ul style="list-style-type: none"> <li>• Currency is not defined in the system.</li> </ul>

Batch Name	Message Number	Error Message	Message Category	Possible Issues
C1-TXNIP	2012	% 1 %2 is invalid. Please enter a valid currency code.  <b>Note:</b> [%1] stands for “Amount 7 Currency Code”; [%2] stands for UDF_CURRENCY_CD_7	17000	The possible issues could be: <ul style="list-style-type: none"> <li>• Currency is not defined in the system.</li> </ul>
C1-TXNIP	2012	% 1 %2 is invalid. Please enter a valid currency code.  <b>Note:</b> [%1] stands for “Amount 8 Currency Code”; [%2] stands for UDF_CURRENCY_CD_8	17000	The possible issues could be: <ul style="list-style-type: none"> <li>• Currency is not defined in the system.</li> </ul>
C1-TXNIP	2012	% 1 %2 is invalid. Please enter a valid currency code.  <b>Note:</b> [%1] stands for “Amount 9 Currency Code”; [%2] stands for UDF_CURRENCY_CD_9	17000	The possible issues could be: <ul style="list-style-type: none"> <li>• Currency is not defined in the system.</li> </ul>
C1-TXNIP	2012	% 1 %2 is invalid. Please enter a valid currency code.  <b>Note:</b> [%1] stands for “Amount 10 Currency Code”; [%2] stands for UDF_CURRENCY_CD_10	17000	The possible issues could be: <ul style="list-style-type: none"> <li>• Currency is not defined in the system.</li> </ul>
C1-TXNIP	2013	The user %1 does not exist in the system. Please enter a valid user ID.  <b>Note:</b> [%1] stands for user ID	17000	The possible issues could be: <ul style="list-style-type: none"> <li>• The user is not defined in the system.</li> </ul>

Batch Name	Message Number	Error Message	Message Category	Possible Issues
C1-TXNIP	2014	<p>%1 derived using %2 by the rule is invalid.</p> <div style="border: 1px solid black; padding: 5px;"> <p><b>Note:</b></p> <p>[%1] stands for “Account Number”</p> <p>[%2] stands for the ACCT_NOX_Val or ACCT_NOX_Col output parameter</p> </div>	17000	<p>The possible issues could be:</p> <ul style="list-style-type: none"> <li>No value is defined for either <b>Account Identifier (ACCT_NOX_Val)</b> or <b>Account Identifier Column Name (ACCT_NOX_Col)</b> output parameter in the rule.</li> </ul>
C1-TXNIP	2014	<p>%1 derived using %2 by the rule is invalid.</p> <div style="border: 1px solid black; padding: 5px;"> <p><b>Note:</b></p> <p>[%1] stands for “Account Identifier Type”</p> <p>[%2] stands for the ACCT_NO_TYPEX_Val or ACCT_NO_TYPEX_Col output parameter</p> </div>	17000	<p>The possible issues could be:</p> <ul style="list-style-type: none"> <li>No value is defined for either <b>Account Identifier Type (ACCT_NO_TYPEX_Val)</b> or <b>Account Identifier Type Column Name (ACCT_NO_TYPEX_Col)</b> output parameter in the rule.</li> </ul>
C1-TXNIP	2014	<p>%1 derived using %2 by the rule is invalid.</p> <div style="border: 1px solid black; padding: 5px;"> <p><b>Note:</b></p> <p>[%1] stands for “Division”</p> <p>[%2] stands for the DIVISIONX_VAL or DIVISIONX_COL output parameter</p> </div>	17000	<p>The possible issues could be:</p> <ul style="list-style-type: none"> <li>No value is defined for either <b>Account Division (DIVISIONX_VAL)</b> or <b>Account Division Column Name (DIVISIONX_COL)</b> output parameter in the rule.</li> </ul>
C1-TXNIP	2014	<p>%1 derived using %2 by the rule is invalid.</p> <div style="border: 1px solid black; padding: 5px;"> <p><b>Note:</b></p> <p>[%1] stands for “Initial Product Code”</p> <p>[%2] stands for the PRODUCTX_Y_Val or PRODUCTX_Y_Col output parameter</p> </div>	17000	<p>The possible issues could be:</p> <ul style="list-style-type: none"> <li>No value is defined for either <b>Product Name (PRODUCTX_Y_Val)</b> or <b>Product Column Name (PRODUCTX_Y_Col)</b> output parameter in the rule.</li> </ul>



Batch Name	Message Number	Error Message	Message Category	Possible Issues
C1-TXNIP	2015	<p>Not able to derive account id for given Account Number %1, Account Number Type Code %2 and Division %3.</p> <p><b>Note:</b> [%1] stands for account identifier; [%2] stands for account identifier type; [%3] stands for division</p>	17000	<p>The possible issues could be:</p> <ul style="list-style-type: none"> <li>The account with the specified account identifier type, account identifier and division is not found in the system.</li> </ul>
C1-TXNIP	2016	<p>Length of the derived %1 using %2 by the rule is greater than %3.</p> <p><b>Note:</b> [%1] stands for “Initial Product Code”; [%2] stands for PRODUCTX_Y_Val or PRODUCTX_Y_Col output parameter; [%3] stands for length of product code (i.e. 30)</p>	17000	<p>The possible issues could be:</p> <ul style="list-style-type: none"> <li>The value specified for the <b>Product Name (PRODUCTX_Y_Val)</b> or <b>Product Column Name (PRODUCTX_Y_Col)</b> output parameter in the rule exceeds the maximum length of 30 characters.</li> </ul>
C1-TXNIP	2016	<p>Length of the derived %1 using %2 by the rule is greater than %3.</p> <p><b>Note:</b> [%1] stands for “Variance Parameter”; [%2] stands for TOUX_Y_Val or TOUX_Y_Col output parameter; [%3] stands for length of variance parameter (i.e. 8)</p>	17000	<p>The possible issues could be:</p> <ul style="list-style-type: none"> <li>The value specified for the <b>TOU (TOUX_Y_Val)</b> or <b>TOU Column Name (TOUX_Y_Col)</b> output parameter in the rule exceeds the maximum length of 8 characters.</li> </ul>

Batch Name	Message Number	Error Message	Message Category	Possible Issues
C1-TXNIP	2016	<p>Length of the derived %1 using %2 by the rule is greater than %3.</p> <p><b>Note:</b> [%1] stands for “Parameter”; [%2] stands for PCDX_Y_Z_VAL output parameter; [%3] stands for length of parameter (i.e. 30)</p>	17000	<p>The possible issues could be:</p> <ul style="list-style-type: none"> <li>The value specified for the <b>Parameter Code (PCDX_Y_Z_VAL)</b> output parameter in the rule exceeds the maximum length of 30 characters.</li> </ul>
C1-TXNIP	2016	<p>Length of the derived %1 using %2 by the rule is greater than %3.</p> <p><b>Note:</b> [%1] stands for “Parameter Value”; [%2] stands for PVLX_Y_Z_VAL or PVLX_Y_Z_COL output parameter; [%3] stands for length of parameter value (i.e. 254)</p>	17000	<p>The possible issues could be:</p> <ul style="list-style-type: none"> <li>The value specified for the <b>Parameter Value Column Name (PVLX_Y_Z_COL)</b> output parameter in the rule exceeds the maximum length of 254 characters.</li> </ul>
C1-TXNIP	2017	<p>Mandatory parameter %1 is missing for %2 %3 and processing date %4.</p> <p><b>Note:</b> [%1] stands for the product parameter code; [%2] stands for “Initial Product Code” [%3] stands for the product code [%4] stands for the processing date</p>	17000	<p>The possible issues could be:</p> <ul style="list-style-type: none"> <li>The mandatory product parameter is not defined as the output parameter in the rule.</li> </ul>

Batch Name	Message Number	Error Message	Message Category	Possible Issues
C1-TXNIP	2018	Value for mandatory parameter %1 is missing for product %2 and processing date %3.  <b>Note:</b> [%1] stands for product parameter code; [%2] stands for product code; [%3] stands for processing date	17000	The possible issues could be: <ul style="list-style-type: none"> <li>No value is defined for the mandatory product parameter in the rule.</li> </ul>
C1-TXNIP	2019	Value of the derived %1 %2 contains '~' or '='.  <b>Note:</b> [%1] stands for parameter code [%2] stands for parameter value	17000	The possible issues could be: <ul style="list-style-type: none"> <li>The parameter code or value contains the equal to (=) and tide (~) symbols.</li> </ul>
C1-TXNIP	2037	Error during executing rules for transaction record type %1, transaction source %2 and processing date %3.  <b>Note:</b> [%1] stands for transaction record type; [%2] stands for transaction source; [%3] stands for processing date	17000	The possible issues could be: <ul style="list-style-type: none"> <li>There is some technical issue while executing the rule or while processing the rule output.</li> <li>No rules are effective on the processing date.</li> <li>The rule type is not defined for the transaction source and transaction record type combination in the system.</li> </ul>
C1-TXNIP	2043	Unable to derive Rule Type with Transaction Source %1 and Transaction Record Type %2.  <b>Note:</b> [%1] stands for transaction source; [%2] stands for transaction record type	17000	The possible issues could be: <ul style="list-style-type: none"> <li>The rule type is not defined for the transaction source and transaction record type combination in the system.</li> </ul>

Batch Name	Message Number	Error Message	Message Category	Possible Issues
C1-TXNIP	2087	Division %1 is invalid. Please enter a valid division for the transaction.  <b>Note:</b> [%1] stands for division	17000	The possible issues could be: <ul style="list-style-type: none"> <li>Division (to which the transaction belongs) is not defined in the system.</li> </ul>
C1-TXNVP	102	{Chunk Size} field invalid	11001	The possible issues could be: <ul style="list-style-type: none"> <li>The value specified for the <b>Chunk Size</b> parameter is less than or equal to one.</li> </ul>
C1-TXNVP	106	Value { Given Transaction Header Id } too long for field { transactionHeaderId }. Maximum length: 14. Found: { Length of given Transaction Header Id}	11001	The possible issues could be: <ul style="list-style-type: none"> <li>The value specified for the <b>Transaction Header ID</b> parameter exceeds the maximum length of 14 characters.</li> </ul>
C1-TXNVP	106	Value { Given Transaction Source Code } too long for field { transactionSource }. Maximum length: 30. Found: { Length of given Transaction Source Code}	11001	The possible issues could be: <ul style="list-style-type: none"> <li>The value specified for the <b>Transaction Source</b> parameter exceeds the maximum length of 30 characters.</li> </ul>
C1-TXNVP	106	Value { Given Transaction Division } too long for field { division }. Maximum length: 5 Found: { Length of given Transaction Division}	11001	The possible issues could be: <ul style="list-style-type: none"> <li>The value specified for the <b>Division</b> parameter exceeds the maximum length of 5 characters.</li> </ul>
C1-TXNVP	1636	Invalid batch run [%1] for [%2] division(s). %3  <b>Note:</b> [%1] stands for batch code; [%2] stands for division; [%3] stands for expected batch code	17000	The possible issues could be: <ul style="list-style-type: none"> <li>You are trying to execute the C1-TXNVP batch before executing the C1-TXNIP batch (which is first mandatory batch in the transaction aggregation cycle).</li> <li>You are trying to execute the C1-TXNVP batch in between the C1-TXNCM and C1-TXNCU batches during the transaction aggregation cycle.</li> </ul>
C1-TXNVP	1638	Transaction Feed Management cycle for individual division(s) is not yet complete. Please complete pending batch runs before starting new cycle for processing [ALL] divisions.	17000	The possible issues could be: <ul style="list-style-type: none"> <li>You are trying to execute this batch for all divisions before completing the transaction aggregation cycle which is initiated for a particular division.</li> </ul>

Batch Name	Message Number	Error Message	Message Category	Possible Issues
C1-TXNVP	1639	Transaction Feed Management cycle for [ALL] divisions is not yet complete. Please complete pending batch runs before starting new cycle for individual division [%1].  <b>Note:</b> [%1] stands for division	17000	The possible issues could be: <ul style="list-style-type: none"> <li>You are trying to execute this batch for a particular division before completing the transaction aggregation cycle which is initiated for all divisions.</li> </ul>
C1-TXNVP	1644	Transaction Feed Management cycle for division(s) [%1] is already in progress with filter [Source= %2, Header= %3] criteria. Filter criteria must be same for complete cycle.  <b>Note:</b> [%1] stands for division; [%2] stands for transaction source; [%3] stands for transaction header ID	17000	The possible issues could be: <ul style="list-style-type: none"> <li>You are trying to execute this batch once again with the same division and different parameters.</li> </ul>
C1-TXNEX	102	{ Chunk Size } field invalid	11001	The possible issues could be: <ul style="list-style-type: none"> <li>The value specified for the <b>Chunk Size</b> parameter is less than or equal to one.</li> </ul>
C1-TXNEX	102	{ Maximum Batch Size } field invalid	11001	The possible issues could be: <ul style="list-style-type: none"> <li>The value specified for the <b>Maximum Batch Count</b> parameter is greater than the value specified for the <b>Chunk Size</b> parameter.</li> </ul>
C1-TXNEX	106	Value { Given Transaction Header Id } too long for field { transactionHeaderId }. Maximum length: 14. Found: { Length of given Transaction Header Id }	11001	The possible issues could be: <ul style="list-style-type: none"> <li>The value specified for the <b>Transaction Header ID</b> parameter exceeds the maximum length of 14 characters.</li> </ul>
C1-TXNEX	106	Value { Given Transaction Source Code } too long for field { transactionSource }. Maximum length: 30. Found: { Length of given Transaction Source Code }	11001	The possible issues could be: <ul style="list-style-type: none"> <li>The value specified for the <b>Transaction Source</b> parameter exceeds the maximum length of 30 characters.</li> </ul>

Batch Name	Message Number	Error Message	Message Category	Possible Issues
C1-TXNEX	106	Value { Given Transaction Division } too long for field { division }. Maximum length: 5 Found: { Length of given Transaction Division }	11001	The possible issues could be: <ul style="list-style-type: none"> <li>The value specified for the <b>Division</b> parameter exceeds the maximum length of 5 characters.</li> </ul>
C1-TXNEX	790	The selected Member account does not have active Contracts.	17000	The possible issues could be: <ul style="list-style-type: none"> <li>There are no contracts for the account in <b>Active, Pending Stop,</b> or <b>Stop</b> status on the transaction date.</li> </ul>
C1-TXNEX	1336	Effective pricing is not available for the product. Please check.	17000	The possible issues could be: <ul style="list-style-type: none"> <li>The effective pricing is not available for the product.</li> </ul>
C1-TXNEX	1392	Invalid configuration of Price Search Algorithm Parameters or Contracts or Schedule Periods.	17000	The possible issues could be: <ul style="list-style-type: none"> <li>The parameter values are either not defined or invalid in the <b>Price Assignment Search</b> algorithm (which is associated with the division).</li> <li>The period in which the transaction date falls is not defined in the aggregation schedule.</li> <li>There are multiple effective contracts of the same contract type (available on the transaction date) in <b>Active, Pending Stop,</b> or <b>Stop</b> status.</li> </ul>
C1-TXNEX	1556	{Maximum Batch Size} field should be greater than zero	17000	The possible issues could be: <ul style="list-style-type: none"> <li>The value specified for the <b>Maximum Batch Count</b> parameter is less than or equal to zero.</li> </ul>
C1-TXNEX	1588	No Schedule Period found for the transaction date.	17000	The possible issues could be: <ul style="list-style-type: none"> <li>The period in which the transaction date falls is not defined in the aggregation schedule.</li> </ul>
C1-TXNEX	1611	Division specific Price Search Algorithm is not configured.	17000	The possible issues could be: <ul style="list-style-type: none"> <li>The <b>Price Assignment Search</b> algorithm is not defined for the division.</li> </ul>

Batch Name	Message Number	Error Message	Message Category	Possible Issues
C1-TXNEX	1612	Price Search Algorithm parameters are not set or are invalid.	17000	The possible issues could be: <ul style="list-style-type: none"> <li>The parameter values are either not defined or invalid in the <b>Price Assignment Search</b> algorithm (which is associated with the division).</li> </ul>
C1-TXNEX	1613	Multiple contracts in Active, Pending Stop, Stop status exists for same contract type.	17000	The possible issues could be: <ul style="list-style-type: none"> <li>There are multiple effective contracts of the same contract type in <b>Active, Pending Stop, or Stop</b> status on the transaction date.</li> </ul>
C1-TXNEX	1636	Invalid batch run [% 1] for [%2] division(s). %3  <div style="border: 1px solid black; padding: 5px; background-color: #f0f0f0;"> <p><b>Note:</b> [% 1] stands for batch code; [%2] stands for division; [%3] stands for expected batch code</p> </div>	17000	The possible issues could be: <ul style="list-style-type: none"> <li>You are trying to execute the C1-TXNEX batch before executing the C1-TXNIP batch (which is first mandatory batch in the transaction aggregation cycle).</li> <li>You are trying to execute the C1-TXNEX batch in between the C1-TXNCM and C1-TXNCU batches during the transaction aggregation cycle.</li> </ul>
C1-TXNEX	1638	Transaction Feed Management cycle for individual division(s) is not yet complete. Please complete pending batch runs before starting new cycle for processing [ALL] divisions.	17000	The possible issues could be: <ul style="list-style-type: none"> <li>You are trying to execute this batch for all divisions before completing the transaction aggregation cycle which is initiated for a particular division.</li> </ul>
C1-TXNEX	1639	Transaction Feed Management cycle for [ALL] divisions is not yet complete. Please complete pending batch runs before starting new cycle for individual division [%1].  <div style="border: 1px solid black; padding: 5px; background-color: #f0f0f0;"> <p><b>Note:</b> [% 1] stands for division</p> </div>	17000	The possible issues could be: <ul style="list-style-type: none"> <li>You are trying to execute this batch for a particular division before completing the transaction aggregation cycle which is initiated for all divisions.</li> </ul>

Batch Name	Message Number	Error Message	Message Category	Possible Issues
C1-TXNEX	1644	<p>Transaction Feed Management cycle for division(s) [%1] is already in progress with filter [Source= %2, Header= %3] criteria. Filter criteria must be same for complete cycle.</p> <p><b>Note:</b> [%1] stands for division; [%2] stands for transaction source; [%3] stands for transaction header ID</p>	17000	<p>The possible issues could be:</p> <ul style="list-style-type: none"> <li>You are trying to execute this batch once again with the same division and different parameters.</li> </ul>
C1-TXNIP	2003	<p>One or more Sub Transactions are in EROR state.</p>	17000	<p>The possible issues could be:</p> <ul style="list-style-type: none"> <li>One or more transaction legs are in the <b>Error (EROR)</b> status.</li> </ul>
C1-TXNEX	2006	<p>No active contract exists for account %1, product %2 and transaction date %3.</p> <p><b>Note:</b> [%1] stands for derived account; [%2] stands for derived product; and [%3] stands for transaction date</p>	17000	<p>The possible issues could be:</p> <ul style="list-style-type: none"> <li>There is no contract with the specified contract type available on the transaction date.</li> <li>The contract is inactive.</li> </ul>
C1-TXNEX	2020	<p>Invalid configuration of Price Search Algorithm Parameters or Contracts or Schedule Periods for division %1, account %2, product %3, transaction date %4 and processing date %5.</p> <p><b>Note:</b> [%1] stands for derived division; [%2] stands for derived account; [%3] stands for derived product; [%4] stands for transaction date; [%5] stands for processing date</p>	17000	<p>The possible issues could be:</p> <ul style="list-style-type: none"> <li>The parameter values are either not defined or invalid in the <b>Price Assignment Search</b> algorithm (which is associated with the division).</li> <li>The period in which the transaction date falls is not defined in the aggregation schedule.</li> <li>There are multiple effective contracts of the same contract type (available on the transaction date) in <b>Active, Pending Stop, or Stop</b> status.</li> </ul>



Batch Name	Message Number	Error Message	Message Category	Possible Issues
C1-TXNEX	2021	<p>Division specific Price Search Algorithm is not configured for division %1 and processing date %2.</p> <p><b>Note:</b> [%1] stands for derived division; [%2] stands for processing date</p>	17000	<p>The possible issues could be:</p> <ul style="list-style-type: none"> <li>The <b>Price Assignment Search</b> algorithm is not defined for the derived division on the processing date.</li> </ul>
C1-TXNEX	2022	<p>Price Search Algorithm parameters are not set or are invalid for division %1 and processing date %2.</p> <p><b>Note:</b> [%1] stands for derived division; [%2] stands for processing date</p>	17000	<p>The possible issues could be:</p> <ul style="list-style-type: none"> <li>The parameter values are either not defined or invalid in the <b>Price Assignment Search</b> algorithm which is associated with the derived division on the processing date.</li> </ul>
C1-TXNEX	2023	<p>Effective pricing is not available for account %1, product %2, parameters %3 and processing date %4.</p> <p><b>Note:</b> [%1] stands for derived account; [%2] stands for derived product; [%3] stands for derived product parameter; [%4] stands for processing date</p>	17000	<p>The possible issues could be:</p> <ul style="list-style-type: none"> <li>The effective pricing is not available for the account, product and product parameters combination on the processing date.</li> </ul>
C1-TXNEX	2024	<p>No Schedule Period found for product %1, price assignment id %2 and transaction date %3.</p> <p><b>Note:</b> [%1] stands for derived product; [%2] stands for price assignment ID; [%3] stands for transaction date</p>	17000	<p>The possible issues could be:</p> <ul style="list-style-type: none"> <li>The period in which the transaction date falls is not defined in the aggregation schedule (which is used in the product pricing).</li> </ul>

Batch Name	Message Number	Error Message	Message Category	Possible Issues
C1-TXNEX	2025	<p>Multiple contracts in Active, Pending Stop, Stop status exists for same contract type against account %1, product %2 and transaction date %3.</p> <div style="border: 1px solid black; padding: 5px;"> <p><b>Note:</b></p> <p>[%1] stands for derived account;</p> <p>[%2] stands for derived product;</p> <p>[%3] stands for transaction date</p> </div>	17000	<p>The possible issues could be:</p> <ul style="list-style-type: none"> <li>There are multiple effective contracts of the same contract type in <b>Active, Pending Stop, or Stop</b> status on the transaction date.</li> </ul>
C1-TXNEX	2026	<p>No active contract exists for account %1, product %2 and transaction date %3.</p> <div style="border: 1px solid black; padding: 5px;"> <p><b>Note:</b></p> <p>[%1] stands for derived account;</p> <p>[%2] stands for derived product;</p> <p>[%3] stands for transaction date</p> </div>	17000	<p>The possible issues could be:</p> <ul style="list-style-type: none"> <li>There are no contracts for the account in <b>Active, Pending Stop, or Stop</b> status on the transaction date.</li> </ul>
C1-TXNSQ	102	{ Maximum Batch Size } field invalid	11001	<p>The possible issues could be:</p> <ul style="list-style-type: none"> <li>The value specified for the <b>Maximum Batch Count</b> parameter is greater than the value specified for the <b>Chunk Size</b> parameter.</li> </ul>
C1-TXNSQ	102	{ Chunk Size } field invalid	11001	<p>The possible issues could be:</p> <ul style="list-style-type: none"> <li>The value specified for the <b>Chunk Size</b> parameter is less than or equal to one.</li> </ul>
C1-TXNSQ	106	Value { Given Transaction Header Id } too long for field { transactionHeaderId }. Maximum length: 14. Found: { Length of given Transaction Header Id }	11001	<p>The possible issues could be:</p> <ul style="list-style-type: none"> <li>The value specified for the <b>Transaction Header ID</b> parameter exceeds the maximum length of 14 characters.</li> </ul>
C1-TXNSQ	106	Value { Given Transaction Source Code } too long for field { transactionSource }. Maximum length: 30. Found: { Length of given Transaction Source Code }	11001	<p>The possible issues could be:</p> <ul style="list-style-type: none"> <li>The value specified for the <b>Transaction Source</b> parameter exceeds the maximum length of 30 characters.</li> </ul>

Batch Name	Message Number	Error Message	Message Category	Possible Issues
C1-TXNSQ	106	Value { Given Transaction Division } too long for field { division }. Maximum length: 5 Found: { Length of given Transaction Division }	11001	The possible issues could be: <ul style="list-style-type: none"> <li>The value specified for the <b>Division</b> parameter exceeds the maximum length of 5 characters.</li> </ul>
C1-TXNSQ	1388	Data configuration error for { ENV_ID }.	17000	The possible issues could be: <ul style="list-style-type: none"> <li>No data exists in the <b>ENV_ID</b> column of the <b>CI_INSTALLATION</b> table.</li> <li>The data available in the <b>ENV_ID</b> column of the <b>CI_INSTALLATION</b> table is not properly cached.</li> </ul>
C1-TXNSQ	1388	Data configuration error for { SQI Fragment }.	17000	The possible issues could be: <ul style="list-style-type: none"> <li>No data exists in the <b>SQL_FRAG</b>, <b>TXN_PRM</b>, <b>SQL_CD</b>, and <b>SQL_FUNC</b> columns of the <b>CI_TXN_SQI_FRAG</b> table.</li> <li>The data available in the <b>SQL_FRAG</b>, <b>TXN_PRM</b>, <b>SQL_CD</b>, and <b>SQL_FUNC</b> columns of the <b>CI_TXN_SQI_FRAG</b> table is not properly cached.</li> </ul>
C1-TXNSQ	1388	Data configuration error for { Price Item SQI }.	17000	The possible issues could be: <ul style="list-style-type: none"> <li>No data exists in the <b>PRICEITEM_CD</b>, <b>CIS_DIVISION</b>, and <b>SQL_CD</b> columns of the <b>CI_PRICEITEM_SQI</b> table.</li> <li>The data available in the <b>PRICEITEM_CD</b>, <b>CIS_DIVISION</b>, and <b>SQL_CD</b> columns of the <b>CI_PRICEITEM_SQI</b> table is not properly cached.</li> </ul>
C1-TXNSQ	1556	{Maximum Batch Size} field should be greater than zero	17000	The possible issues could be: <ul style="list-style-type: none"> <li>The value specified for the <b>Maximum Batch Count</b> parameter is less than or equal to zero.</li> </ul>

Batch Name	Message Number	Error Message	Message Category	Possible Issues
C1-TXNSQ	1636	Invalid batch run [% 1] for [%2] division(s). %3  <b>Note:</b> [% 1] stands for batch code; [%2] stands for division; [%3] stands for expected batch code	17000	The possible issues could be: <ul style="list-style-type: none"> <li>You are trying to execute the C1-TXNSQ batch before executing the C1-TXNIP batch (which is first mandatory batch in the transaction aggregation cycle).</li> <li>You are trying to execute the C1-TXNSQ batch in between the C1-TXNCM and C1-TXNCU batches during the transaction aggregation cycle.</li> </ul>
C1-TXNSQ	1638	Transaction Feed Management cycle for individual division(s) is not yet complete. Please complete pending batch runs before starting new cycle for processing [ALL] divisions.	17000	The possible issues could be: <ul style="list-style-type: none"> <li>You are trying to execute this batch for all divisions before completing the transaction aggregation cycle which is initiated for a particular division.</li> </ul>
C1-TXNSQ	1639	Transaction Feed Management cycle for [ALL] divisions is not yet complete. Please complete pending batch runs before starting new cycle for individual division [%1].  <b>Note:</b> [% 1] stands for division	17000	The possible issues could be: <ul style="list-style-type: none"> <li>You are trying to execute this batch for a particular division before completing the transaction aggregation cycle which is initiated for all divisions.</li> </ul>
C1-TXNSQ	1644	Transaction Feed Management cycle for division(s) [%1] is already in progress with filter [Source= %2, Header= %3] criteria. Filter criteria must be same for complete cycle.  <b>Note:</b> [% 1] stands for division; [%2] stands for transaction source; [%3] stands for transaction header ID	17000	The possible issues could be: <ul style="list-style-type: none"> <li>You are trying to execute this batch once again with the same division and different parameters.</li> </ul>
C1-TXNSQ	2003	One or more Sub Transactions are in EROR state.	17000	The possible issues could be: <ul style="list-style-type: none"> <li>One or more transaction legs are in the <b>Error (EROR)</b> status.</li> </ul>

Batch Name	Message Number	Error Message	Message Category	Possible Issues
C1-TXNSQ	2026	<p>SQIs not configured for product %1 and division %2.</p> <div style="border: 1px solid black; padding: 5px; background-color: #f0f0f0;"> <p><b>Note:</b>  [%1] stands for final product code;  [%2] stands for derived division</p> </div>	17000	<p>The possible issues could be:</p> <ul style="list-style-type: none"> <li>The SQIs are not defined for the product — division combination.</li> </ul>
C1-TXNSQ	2027	Currency Conversion from Currency [%1] to Currency [%2] not successful.	17000	<p>The possible issues could be:</p> <ul style="list-style-type: none"> <li>The exchange rate is not available during currency conversion.</li> </ul>
C1-TXNCM	102	{Chunk Size} field invalid	11001	<p>The possible issues could be:</p> <ul style="list-style-type: none"> <li>The value specified for the <b>Chunk Size</b> parameter is less than or equal to one.</li> </ul>
C1-TXNCM	102	{ Maximum Batch Size } field invalid	11001	<p>The possible issues could be:</p> <ul style="list-style-type: none"> <li>The value specified for the <b>Maximum Batch Count</b> parameter is greater than the value specified for the <b>Chunk Size</b> parameter.</li> </ul>
C1-TXNCM	106	Value { Given Transaction Header Id } too long for field { transactionHeaderId }. Maximum length: 14. Found: { Length of given Transaction Header Id }	11001	<p>The possible issues could be:</p> <ul style="list-style-type: none"> <li>The value specified for the <b>Transaction Header ID</b> parameter exceeds the maximum length of 14 characters.</li> </ul>
C1-TXNCM	106	Value { Given Transaction Source Code } too long for field { transactionSource }. Maximum length: 30. Found: { Length of given Transaction Source Code }	11001	<p>The possible issues could be:</p> <ul style="list-style-type: none"> <li>The value specified for the <b>Transaction Source</b> parameter exceeds the maximum length of 30 characters.</li> </ul>
C1-TXNCM	106	Value { Given Transaction Division } too long for field { division }. Maximum length: 5 Found: { Length of given Transaction Division }	11001	<p>The possible issues could be:</p> <ul style="list-style-type: none"> <li>The value specified for the <b>Division</b> parameter exceeds the maximum length of 5 characters.</li> </ul>

Batch Name	Message Number	Error Message	Message Category	Possible Issues
C1-TXNCM	1393	Either the transaction feed management setup is incomplete, or there is no active contract available.	17000	The possible issues could be: <ul style="list-style-type: none"> <li>The SQIs are not defined for the product — division combination.</li> <li>The transaction aggregation rule is not defined for the SQL.</li> <li>There is no contract with the specified contract type available in the system.</li> <li>The contract is inactive.</li> </ul>
C1-TXNCM	1556	{Maximum Batch Size} field should be greater than zero	17000	The possible issues could be: <ul style="list-style-type: none"> <li>The value specified for the <b>Maximum Batch Count</b> parameter is less than or equal to zero.</li> </ul>
C1-TXNCM	1636	Invalid batch run [% 1] for [%2] division(s). %3  <div style="border: 1px solid black; padding: 5px; background-color: #f0f0f0;"> <p><b>Note:</b>  [% 1] stands for batch code;  [% 2] stands for division;  [% 3] stands for expected batch code</p> </div>	17000	The possible issues could be: <ul style="list-style-type: none"> <li>You are trying to execute the C1-TXNCM batch before executing the C1-TXNIP batch.</li> </ul>
C1-TXNCM	1638	Transaction Feed Management cycle for individual division(s) is not yet complete. Please complete pending batch runs before starting new cycle for processing [ALL] divisions.	17000	The possible issues could be: <ul style="list-style-type: none"> <li>You are trying to execute this batch for all divisions before completing the transaction aggregation cycle which is initiated for a particular division.</li> </ul>
C1-TXNCM	1639	Transaction Feed Management cycle for [ALL] divisions is not yet complete. Please complete pending batch runs before starting new cycle for individual division [% 1].  <div style="border: 1px solid black; padding: 5px; background-color: #f0f0f0;"> <p><b>Note:</b> [% 1] stands for division</p> </div>	17000	The possible issues could be: <ul style="list-style-type: none"> <li>You are trying to execute this batch for a particular division before completing the transaction aggregation cycle which is initiated for all divisions.</li> </ul>

Batch Name	Message Number	Error Message	Message Category	Possible Issues
C1-TXNCM	1644	Transaction Feed Management cycle for division(s) [%1] is already in progress with filter [Source= %2, Header= %3] criteria. Filter criteria must be same for complete cycle.  <b>Note:</b> [%1] stands for division; [%2] stands for transaction source; [%3] stands for transaction header ID	17000	The possible issues could be: <ul style="list-style-type: none"> <li>You are trying to execute this batch once again with the same division and different parameters.</li> </ul>
C1-TXNCM	2003	One or more Sub Transactions are in EROR state.	17000	The possible issues could be: <ul style="list-style-type: none"> <li>One or more transaction legs are in the <b>Error (EROR)</b> status.</li> </ul>
C1-TXNCM	2026	SQIs not configured for product %1 and division %2.  <b>Note:</b> [%1] stands for final product code; [%2] stands for derived division	17000	The possible issues could be: <ul style="list-style-type: none"> <li>The SQIs are not defined for the product — division combination.</li> </ul>
C1-TXNCM	2027	Currency Conversion from Currency [%1] to Currency [%2] not successful.	17000	The possible issues could be: <ul style="list-style-type: none"> <li>The exchange rate is not available during currency conversion.</li> </ul>
C1-TXNCU	101	{ Disaggregation From Date } field missing	11001	The possible issues could be: <ul style="list-style-type: none"> <li>No value is specified for the <b>Disaggregate Transactions From Date</b> parameter when the request type is set to DISAGG.</li> </ul>
C1-TXNCU	101	{ Request Type } field missing	11001	The possible issues could be: <ul style="list-style-type: none"> <li>No value is specified for the <b>Request Type</b> parameter.</li> </ul>
C1-TXNCU	101	{ Transaction Header Id } field missing	11001	The possible issues could be: <ul style="list-style-type: none"> <li>No value is specified for the <b>Transaction Header ID</b> parameter when the request type is set to CNCL.</li> </ul>

Batch Name	Message Number	Error Message	Message Category	Possible Issues
C1-TXNCU	102	{ Chunk Size } field invalid	11001	The possible issues could be: <ul style="list-style-type: none"> <li>The value specified for the <b>Chunk Size</b> parameter is less than or equal to one.</li> </ul>
C1-TXNCU	102	{ Maximum Batch Size } field invalid	11001	The possible issues could be: <ul style="list-style-type: none"> <li>The value specified for the <b>Maximum Batch Count</b> parameter is greater than the value specified for the <b>Chunk Size</b> parameter.</li> </ul>
C1-TXNCU	102	{ Request Type } field invalid	11001	The possible issues could be: <ul style="list-style-type: none"> <li>The value other than 'EROR', 'CNCL' or 'DISAGG' is specified for the <b>Request Type</b> parameter.</li> </ul>
C1-TXNCU	102	{ Transaction Division } field invalid	11001	The possible issues could be: <ul style="list-style-type: none"> <li>The value for the <b>Division</b> parameter is specified when the request type is set to CNCL.</li> </ul>
C1-TXNCU	102	{ Transaction Source Code } field invalid	11001	The possible issues could be: <ul style="list-style-type: none"> <li>The value for the <b>Transaction Source</b> parameter is specified when the request type is set to CNCL.</li> </ul>
C1-TXNCU	102	{ Account Id } field invalid	11001	The possible issues could be: <ul style="list-style-type: none"> <li>The value for the <b>Account ID</b> parameter is specified when the request type is set to CNCL.</li> </ul>
C1-TXNCU	102	{ Bill Cycle Code } field invalid	11001	The possible issues could be: <ul style="list-style-type: none"> <li>The value for the <b>Bill Cycle</b> parameter is specified when the request type is set to CNCL.</li> </ul>
C1-TXNCU	102	{ Disaggregation From Date } field invalid	11001	The possible issues could be: <ul style="list-style-type: none"> <li>The value for the <b>Disaggregate Transactions From Date</b> parameter is specified when the request type is set to CNCL.</li> </ul>
C1-TXNCU	102	{ Account Id } field invalid	11001	The possible issues could be: <ul style="list-style-type: none"> <li>The value for the <b>Account ID</b> parameter is specified when the request type is set to EROR.</li> </ul>



Batch Name	Message Number	Error Message	Message Category	Possible Issues
C1-TXNCU	102	{Bill Cycle Code } field invalid	11001	The possible issues could be: <ul style="list-style-type: none"> <li>The value for the <b>Bill Cycle</b> parameter is specified when the request type is set to EROR.</li> </ul>
C1-TXNCU	102	{Disaggregation From Date } field invalid	11001	The possible issues could be: <ul style="list-style-type: none"> <li>The value for the <b>Disaggregate Transactions From Date</b> parameter is specified when the request type is set to EROR.</li> </ul>
C1-TXNCU	102	{Transaction Header Id } field invalid	11001	The possible issues could be: <ul style="list-style-type: none"> <li>The value for the <b>Transaction Header ID</b> parameter is specified when the request type is set to DISAGG.</li> </ul>
C1-TXNCU	102	{ Transaction Source Code } field invalid	11001	The possible issues could be: <ul style="list-style-type: none"> <li>The value for the <b>Transaction Source</b> parameter is specified when the request type is set to DISAGG.</li> </ul>
C1-TXNCU	106	Value { Given Transaction Header Id } too long for field { transactionHeaderId }. Maximum length: 14. Found: { Length of given Transaction Header Id}	11001	The possible issues could be: <ul style="list-style-type: none"> <li>The value specified for the <b>Transaction Header ID</b> parameter exceeds the maximum length of 14 characters.</li> </ul>
C1-TXNCU	106	Value { Given Transaction Source Code } too long for field { transactionSource }. Maximum length: 30. Found: { Length of given Transaction Source Code}	11001	The possible issues could be: <ul style="list-style-type: none"> <li>The value specified for the <b>Transaction Source</b> parameter exceeds the maximum length of 30 characters.</li> </ul>
C1-TXNCU	106	Value { Given Transaction Division } too long for field { division }. Maximum length: 5 Found: { Length of given Transaction Division}	11001	The possible issues could be: <ul style="list-style-type: none"> <li>The value specified for the <b>Division</b> parameter exceeds the maximum length of 5 characters.</li> </ul>
C1-TXNCU	1388	Data configuration error for { SQL Fragment }.	17000	The possible issues could be: <ul style="list-style-type: none"> <li>No data exists in the SQL_FRAG, TXN_PRM, SQL_CD, and SQL_FUNC columns of the CI_TXN_SQL_FRAG table.</li> <li>The data available in the SQL_FRAG, TXN_PRM, SQL_CD, and SQL_FUNC columns of the CI_TXN_SQL_FRAG table is not properly cached.</li> </ul>

Batch Name	Message Number	Error Message	Message Category	Possible Issues
C1-TXNCU	1388	Data configuration error for { Price Item SQI }.	17000	The possible issues could be: <ul style="list-style-type: none"> <li>No data exists in the PRICEITEM_CD, CIS_DIVISION, and SQI_CD columns of the CI_PRICEITEM_SQI table.</li> <li>The data available in the PRICEITEM_CD, CIS_DIVISION, and SQI_CD columns of the CI_PRICEITEM_SQI table is not properly cached.</li> </ul>
C1-TXNCU	1391	Bill is completed hence cant cancel the header.	17000	The possible issues could be: <ul style="list-style-type: none"> <li>You are trying to cancel a transaction feed for which a bill with the <b>Complete</b> status already exists in the system.</li> </ul>
C1-TXNCU	1424	There are pending bills for the feed you want to cancel. Please execute the Pending Bill Deletion (C1-DELBL) batch.	17000	The possible issues could be: <ul style="list-style-type: none"> <li>The <b>Pending Bill Deletion (C1-DELBL)</b> batch is not yet executed to delete the bills (generated for the feed) which are in the <b>Pending</b> status.</li> </ul>
C1-TXNCU	1556	{Maximum Batch Size} field should be greater than zero	17000	The possible issues could be: <ul style="list-style-type: none"> <li>The value specified for the <b>Maximum Batch Count</b> parameter is less than or equal to zero.</li> </ul>
C1-TXNCU	1636	Invalid batch run [%1] for [%2] division(s). %3  <div style="border: 1px solid black; padding: 5px; background-color: #f0f0f0;"> <p><b>Note:</b>  [%1] stands for batch code;  [%2] stands for division;  [%3] stands for expected batch code</p> </div>	17000	The possible issues could be: <ul style="list-style-type: none"> <li>You are trying to execute the C1-TXNCU batch before executing the C1-TXNIP or C1-TXNCM batch.</li> </ul>
C1-TXNCU	1638	Transaction Feed Management cycle for individual division(s) is not yet complete. Please complete pending batch runs before starting new cycle for processing [ALL] divisions.	17000	The possible issues could be: <ul style="list-style-type: none"> <li>You are trying to execute this batch for all divisions before completing the transaction aggregation cycle which is initiated for a particular division.</li> </ul>

Batch Name	Message Number	Error Message	Message Category	Possible Issues
C1-TXNCU	1639	Transaction Feed Management cycle for [ALL] divisions is not yet complete. Please complete pending batch runs before starting new cycle for individual division [%1].  <b>Note:</b> [%1] stands for division	17000	The possible issues could be: <ul style="list-style-type: none"> <li>You are trying to execute this batch for a particular division before completing the transaction aggregation cycle which is initiated for all divisions.</li> </ul>
C1-TXNCU	1644	Transaction Feed Management cycle for division(s) [%1] is already in progress with filter [Source= %2, Header= %3] criteria. Filter criteria must be same for complete cycle.  <b>Note:</b> [%1] stands for division; [%2] stands for transaction source; [%3] stands for transaction header ID	17000	The possible issues could be: <ul style="list-style-type: none"> <li>You are trying to execute this batch once again with the same division and different parameters.</li> </ul>
C1-TXNRB	102	{ Chunk Size } field invalid	11001	The possible issues could be: <ul style="list-style-type: none"> <li>The value specified for the <b>Chunk Size</b> parameter is less than or equal to one.</li> </ul>
C1-TXNRB	102	{ Maximum Batch Size } field invalid	11001	The possible issues could be: <ul style="list-style-type: none"> <li>The value specified for the <b>Maximum Batch Count</b> parameter is greater than the value specified for the <b>Chunk Size</b> parameter.</li> </ul>
C1-TXNRB	102	{ Status Value } field invalid	11001	The possible issues could be: <ul style="list-style-type: none"> <li>The value other than 'ERROR' or 'IGNR' is specified for the <b>Transaction Status</b> parameter.</li> </ul>
C1-TXNRB	102	{ RollBack From Date } field invalid	11001	The possible issues could be: <ul style="list-style-type: none"> <li>The date specified in the <b>Rollback From Date</b> parameter is later than the date specified in the <b>Rollback To Date</b> parameter.</li> </ul>
C1-TXNRB	1556	{Maximum Batch Size} field should be greater than zero	17000	The possible issues could be: <ul style="list-style-type: none"> <li>The value specified for the <b>Maximum Batch Count</b> parameter is less than or equal to zero.</li> </ul>

Batch Name	Message Number	Error Message	Message Category	Possible Issues
C1-DELBL	101	{ Transaction Header Id } field missing	11001	The possible issues could be: <ul style="list-style-type: none"> <li>No value is specified for the <b>Transaction Header ID</b> parameter.</li> </ul>
C1-DELBL	102	{ Chunk Size } field invalid	11001	The possible issues could be: <ul style="list-style-type: none"> <li>The value specified for the <b>Chunk Size</b> parameter is less than or equal to one.</li> </ul>
C1-DELBL	106	Value { Given Transaction Header Id } too long for field { transactionHeaderId }. Maximum length: 14. Found: { Length of given Transaction Header Id }	11001	The possible issues could be: <ul style="list-style-type: none"> <li>The value specified for the <b>Transaction Header ID</b> parameter exceeds the maximum length of 14 characters.</li> </ul>
C1-DELBL	1391	Bill is completed or bill segment is frozen or pending-cancelled hence can not cancel the header.	17000	The possible issues could be: <ul style="list-style-type: none"> <li>You are trying to cancel a transaction feed for which a bill with the <b>Pending</b> status is already generated in the system. This pending bill has a bill segment in either <b>Frozen</b> or <b>Pending Cancel</b> status.</li> </ul>
C1-DELBL	1556	{ Maximum Batch Size } field should be greater than zero	17000	The possible issues could be: <ul style="list-style-type: none"> <li>The value specified for the <b>Maximum Batch Count</b> parameter is less than or equal to zero.</li> </ul>
C1-TXCNC	101	{ Transaction Header Id } field missing	11001	The possible issues could be: <ul style="list-style-type: none"> <li>No value is specified for the <b>Transaction Header ID</b> parameter.</li> </ul>
C1-TXCNC	102	{ Chunk Size } field invalid	11001	The possible issues could be: <ul style="list-style-type: none"> <li>The value specified for the <b>Chunk Size</b> parameter is less than or equal to one.</li> </ul>
C1-TXCNC	102	{ Maximum Batch Size } field invalid	11001	The possible issues could be: <ul style="list-style-type: none"> <li>The value specified for the <b>Maximum Batch Count</b> parameter is greater than the value specified for the <b>Chunk Size</b> parameter.</li> </ul>

Batch Name	Message Number	Error Message	Message Category	Possible Issues
C1-TXCNC	1391	Bill is completed or bill segment is frozen or pending-cancelled hence can not cancel the header.	17000	The possible issues could be: <ul style="list-style-type: none"> <li>You are trying to cancel a transaction feed for which a bill with the <b>Pending</b> status is already generated in the system. This pending bill has a bill segment in either <b>Frozen</b> or <b>Pending Cancel</b> status.</li> </ul>
C1-TXCNC	1424	There are pending bills for the feed you want to cancel. Please execute the Pending Bill Deletion (C1-DELBL) batch.	17000	The possible issues could be: <ul style="list-style-type: none"> <li>The <b>Pending Bill Deletion (C1-DELBL)</b> batch is not yet executed to delete the bills (generated for the feed) which are in the <b>Pending</b> status.</li> </ul>
C1-TXCNC	1556	{Maximum Batch Size} field should be greater than zero	17000	The possible issues could be: <ul style="list-style-type: none"> <li>The value specified for the <b>Maximum Batch Count</b> parameter is less than or equal to zero.</li> </ul>
C1-DISTG	102	{Division} field invalid	11001	The possible issues could be: <ul style="list-style-type: none"> <li>Division is not defined in the system.</li> </ul>
C1-DISTG	102	{ Billing Cycle Code } field invalid	11001	The possible issues could be: <ul style="list-style-type: none"> <li>Bill cycle is not defined in the system.</li> </ul>
C1-IDENT	102	{Chunk Size} field invalid	11001	The possible issues could be: <ul style="list-style-type: none"> <li>The value specified for the <b>Chunk Size</b> parameter is less than or equal to one.</li> </ul>
C1-IDENT	1660	Disaggregate Transactions From Date would impose partial disaggregation for some billable charges	17000	The possible issues could be: <ul style="list-style-type: none"> <li>The identified aggregated billable charges aggregate transactions whose transaction date falls before the disaggregate transactions from date.</li> </ul>
C1-DRSUA	102	{Chunk Size} field invalid	11001	The possible issues could be: <ul style="list-style-type: none"> <li>The value specified for the <b>Chunk Size</b> parameter is less than or equal to one.</li> </ul>
C1-DRSUA	102	{Chunk Size} field invalid	11001	The possible issues could be: <ul style="list-style-type: none"> <li>The value specified for the <b>Chunk Size</b> parameter is less than or equal to one.</li> </ul>

Batch Name	Message Number	Error Message	Message Category	Possible Issues
C1-PDTXN	102	{ Chunk Size } field invalid	11001	The possible issues could be: <ul style="list-style-type: none"> <li>The value specified for the <b>Chunk Size</b> parameter is less than or equal to one.</li> </ul>
C1-PDTXN	102	{ Maximum Batch Size } field invalid	11001	The possible issues could be: <ul style="list-style-type: none"> <li>The value specified for the <b>Maximum Batch Count</b> parameter is greater than the value specified for the <b>Chunk Size</b> parameter.</li> </ul>
C1-PDTXN	1556	{ Maximum Batch Size } field should be greater than zero	17000	The possible issues could be: <ul style="list-style-type: none"> <li>The value specified for the <b>Maximum Batch Count</b> parameter is less than or equal to zero.</li> </ul>

## Feed Management Dashboard

The **Feed Management Dashboard** screen allows you to view the details of a transaction feed. It allows you to drill down and view:

- Transaction volume details of a feed at the division level
- Transactions in a feed which belong to a division
- Legs of a transaction
- SQIs which are associated with the price item-division combination to which a transaction is mapped
- Calculation lines generated for a transaction leg
- Characteristics defined for each calculation line

This screen consists of the following zones:

- [Search - Feed Level](#) on page 950
- [Division Level Information](#) on page 952
- [Transaction Level Information](#) on page 953
- [Transaction Leg Information](#) on page 954
- [Transaction Leg Service Quantity](#) on page 955
- [Transaction Leg Calculation Lines](#) on page 955
- [Transaction Leg Calc Line Characteristics](#) on page 957

### Search - Feed Level

The **Search - Feed Level** zone allows you to search for a transaction feed using various search criteria. You can view the details of a transaction feed which is already uploaded in the system. This zone contains the following two sections:

- Search Criteria** - The **Search Criteria** section contains the following fields:

Field Name	Field Description	Mandatory (Yes or No)
Feed Header Date From	Used to search for transaction feeds having header date later than or equal to the specified date.	No
Feed Header Date To	Used to search for transaction feeds having header date earlier than or equal to the specified date.	No
Transaction Source	Used to search for transaction feeds received from a particular transaction source.	No
File Name	Used to search for a transaction feed based on the file name.	No
Feed Load Date From	Used to search for transaction feeds which are uploaded on or later than the specified date.	No
Feed Load Date To	Used to search for transaction feeds which are uploaded on or earlier than the specified date.	No
Transaction Header ID	Used to search for a transaction feed based on the header ID.	No

- **Search Results** - On clicking the **Search** button, the search results appear based on the specified search criteria. The **Search Results** section contains the following columns:

Column Name	Column Description
File Name	Displays the name of the file from where the transaction feed is uploaded.
Transaction Source	Displays the transaction source from where the transaction feed is received.
Transaction Header ID	Displays the transaction header ID. <b>Note:</b> The transaction header ID is generated automatically when the file is uploaded.
Transaction Header External ID	Displays the ID mentioned in the file header.
Feed Header Date	Displays the date mentioned in the file header.
Feed Load Date	Displays the date when the transaction feed was uploaded in the system.
Feed Status	Displays the status of the transaction feed. The valid values are: <ul style="list-style-type: none"> <li>• <b>Uploaded</b> - Indicates that the transaction feed is uploaded.</li> <li>• <b>Validated</b> - Indicates that the file header is validated.</li> <li>• <b>Cancelled</b> - Indicates that the transaction feed is cancelled.</li> <li>• <b>Invalid</b> - Indicates that the file header validation failed.</li> </ul>
Error Message	Indicates the reason why the file header validation failed.
Total Volume	Displays the total transaction volume of the feed.
Uploaded Volume	Displays the total transaction volume which is uploaded in the system.
INPD Volume	Displays the total transaction volume which is validated and for which price item is determined in the system.
Completed Volume	Displays the total transaction volume for which billable charges are created and completed in the system.

Column Name	Column Description
Error Volume	Displays the total transaction volume which could not pass through the validation, price item determination, or billable charge creation process.
Cancelled Volume	Displays the total transaction volume which is cancelled in the system.
Ignored Volume	Displays the total transaction volume which is ignored in the system.
Invalid Volume	Displays the total transaction volume which is invalid.

### Related Topics

For more information on...	See...
How to search for a transaction feed	<a href="#">Searching for a Transaction Feed</a> on page 957

## Division Level Information

The **Division Level Information** zone allows you to drill down and view the transaction volume details of a feed at the division level. This zone contains the following two sections:

- **Search Criteria** — The **Search Criteria** section contains the following fields:

Field Name	Field Description	Mandatory (Yes or No)
Division	Used when you want to view the transaction volume details of a particular division received through the feed.  <b>Note:</b> You can only view those divisions to which you have access in the <b>Division</b> list.	No

- **Search Results** — On clicking the **Search** button, the search results are filtered based on the specified search criteria. The **Search Results** section contains the following columns:

Column Name	Column Description
Division	Indicates the division.
Total Volume	Displays the total transaction volume of the division.
Uploaded Volume	Displays the total transaction volume (of the division) which is uploaded in the system.
INPD Volume	Displays the total transaction volume (of the division) which is validated and for which price item is determined in the system.
Completed Volume	Displays the total transaction volume (of the division) for which billable charges are created and completed in the system.
Error Volume	Displays the total transaction volume (of the division) which could not pass through the validation, price item determination, or billable charge creation process.
Cancelled Volume	Displays the total transaction volume (of the division) which is cancelled in the system.
Ignored Volume	Displays the total transaction volume (of the division) which is ignored in the system.
Invalid Volume	Displays the total transaction volume (of the division) which is invalid.



By default, the **Division Level Information** zone does not appear in the **Feed Management Dashboard** screen. It appears only when you click the **Broadcast**  icon corresponding to the transaction feed in the **Search — Feed Level** zone.

### Related Topics

For more information on...	See...
How to view the division level details of a transaction feed	<a href="#">Viewing Division Level Details of a Transaction Feed</a> on page 958

## Transaction Level Information

The **Transaction Level Information** zone lists transactions in a feed which belong to a division. This zone contains the following two sections:

- **Search Criteria** — The **Search Criteria** section contains the following fields:

Field Name	Field Description	Mandatory (Yes or No)
Account Identifier Type	Used to select the identifier type based on which you want to search transactions of an account.	No
Account Identifier	Used to search transactions which are performed for a particular account.	No
Transaction Source	Used to search transactions received from a particular transaction source.	No
Transaction Record Type	Used to search transactions with a particular record type.	No
Transaction Status	Used to search transactions with a particular status.	No
External Reference Number	Used to search a transaction with a particular external reference number.	No

- **Search Results** — On clicking the **Search** button, the search results are filtered based on the specified search criteria. The **Search Results** section contains the following columns:

Column Name	Column Description
Transaction ID	Displays the transaction ID.
External Reference Number	Displays the external reference number of the transaction.
Division	Indicates the division to which the transaction belongs.
Transaction Record Type	Displays the record type of the transaction.
Transaction Date	Displays the date when the transaction was performed.
Account Identifier Type	Displays the type of account identifier.
Account Identifier	Indicates the account for which the transaction was performed.
Transaction Volume	Displays the transaction volume.
Transaction Amount	Displays the transaction amount.
Credit/Debit Indicator	Indicates whether the transaction is a debit or credit transaction.

Column Name	Column Description
Customer Reference Number	Indicates the customer who performed the transaction.
Transaction Status	Indicates the status of the transaction.
Error Message	Indicates the reason why the validation, price item determination, or billable charge creation process failed.
Rule	Indicates the rule which was met while determining initial price item for the transaction.  <b>Note:</b> It has a link. On clicking the link, the <b>Rule</b> screen appears where you can view the details of the rule.
Transaction Information	Displays additional information about the transaction.  <b>Note:</b> It has a link. On clicking the link, the <b>Transaction Details</b> screen appears where you can view the details of the transaction.

**Related Topics**

For more information on...	See...
How to view the transaction details of a division	<a href="#">Viewing Transactions that Belong to a Division</a> on page 958

**Transaction Leg Information**

The **Transaction Leg Information** zone lists the legs of a transaction. It contains the following columns:

Column Name	Column Description
Transaction ID	Indicates the transaction to which the transaction leg belongs.
Sequence	Displays the sequence number of transaction leg.
Account Identifier Type	Indicates the type of account identifier to which the transaction is mapped.
Account Identifier	Indicates the account which will bear the charges for the transaction.
Price Item	Indicates the price item to which the transaction is mapped.
Variance	Indicates the variance parameter which is used along with the price item for determining price item pricing.  <b>Note:</b> This column appears only when the <b>Multi Price Parameter</b> option type of the <b>Multi Parameter Based Pricing (C1_PPARM_FLG)</b> feature configuration is set to <b>False</b> .
Price Item Parameters	Displays a comma-separated list of parameter values. It indicates the price item parameters and their values which are used along with the price item for determining price item pricing.  <b>Note:</b> This column appears only when the <b>Multi Price Parameter</b> option type of the <b>Multi Parameter Based Pricing (C1_PPARM_FLG)</b> feature configuration is set to <b>True</b> .

Column Name	Column Description
Billable Charge ID	<p>Indicates the billable charge which is created for the transaction leg.</p> <p><b>Note:</b> The data appears in this column only when the billable charge is created for the transaction leg. It has a link. On clicking the link, the <b>Billable Charge</b> screen appears where you can view the details of the billable charge.</p>
Transaction Calculation ID	<p>Displays the transaction calculation ID.</p> <p><b>Note:</b> The data appears in this column only when the transaction leg is rated before billing.</p>
Aggregation Parameter Group ID	Indicates the aggregation parameter group using which the transaction leg is aggregated in the billable charge.

By default, the **Transaction Leg Information** zone does not appear in the **Feed Management Dashboard** screen. It appears only when you click the **Broadcast**  icon corresponding to the transaction in the **Transaction Level Information** zone.

#### **Related Topics**

For more information on...	See...
How to view the legs of a transaction	<a href="#">Viewing Legs of a Transaction</a> on page 958

## **Transaction Leg Service Quantity**

The **Transaction Leg Service Quantity** zone lists the SQIs which are associated with the price item-division combination to which a transaction is mapped. It contains the following columns:

Column Name	Column Description
SQI	Indicates the service quantity identifier.
Daily Service Quantity	Displays the SQI value which is calculated using the transaction aggregation rule defined for the price item - division combination.

By default, the **Transaction Leg Service Quantity** zone does not appear in the **Feed Management Dashboard** screen. It appears only when you click the **Broadcast**  icon corresponding to the transaction leg, which is rated before billing, in the **Transaction Leg Information** zone.

#### **Related Topics**

For more information on...	See...
How to view the SQIs calculated for a transaction leg	<a href="#">Viewing the SQIs Calculated for a Transaction Leg</a> on page 959

## **Transaction Leg Calculation Lines**

During the pass through charge calculation, a calculation line is created for each rate component. The **Transaction Leg Calculation Lines** zone lists the calculation lines created for a transaction leg. It contains the following columns:

Column Name	Column Description
Transaction Calculation ID	Displays the transaction calculation ID.
Sequence	Indicates the sequence in which the calculation line was created. It is the sequence of the rate component which is used in the rate schedule.
Price Component ID	Indicates the price component which is used during calculation.
Rate	Displays the rate which is used for calculation.
SQI	Indicates the service quantity identifier.
Billable Service Quantity	Displays the SQI value used by the rates engine for calculation.
Calculated Amount	Displays the calculated charge amount which is rounded off. This amount appears in the invoice currency.
Precise Calculated Amount	Displays the calculated charge amount. This amount appears in the invoice currency.
Exempt Amount	Displays the amount of the calculated charge that the person does not have to pay due to tax exemption.
Base Amount	Displays the total amount derived from the cross-referenced line(s) that the current line then used to calculate the charge amount.
Pricing Amount	Displays the calculated charge amount. This amount appears in the pricing currency.
Exchange Rate	Indicates the exchange rate which is used when the invoice currency is different from the pricing currency.
Print	Indicates whether information about the calculation line must be printed on the person's bill. The valid values are: <ul style="list-style-type: none"> <li>• Y</li> <li>• N</li> </ul>
Description on Bill	Displays the summarized information about the calculation line that will be printed on the bill.
Distribution Code	Indicates the distribution code associated with the rate component.
Pricing Currency	Indicates the currency in which the price item pricing is defined.
Aggregation Parameter Group ID	Indicates the aggregation parameter group using which the transaction leg is aggregated in the billable charge.

By default, the **Transaction Leg Calculation Lines** zone does not appear in the **Feed Management Dashboard** screen. It appears only when you click the **Broadcast**  icon corresponding to the transaction leg, which is rated before billing, in the **Transaction Leg Information** zone.

### **Related Topics**

For more information on...	See...
How to view the calculation lines of a transaction leg	<a href="#">Viewing the Calculation Lines of a Transaction Leg</a> on page 960

## Transaction Leg Calc Line Characteristics

The **Transaction Leg Calc Line Characteristics** zone lists the characteristics defined for each calculation line. It contains the following columns:

Column Name	Column Description
Transaction Calculation ID	Displays the transaction calculation ID.
Sequence	Indicates the sequence in which the calculation line was created. It is the sequence of the rate component which is used in the rate schedule.
Characteristic Type	Indicates the characteristic type.
Characteristic Value	Displays the value of the characteristic type.

By default, the **Transaction Leg Calc Line Characteristics** zone does not appear in the **Feed Management Dashboard** screen. It appears only when you click the **Broadcast**  icon corresponding to the transaction leg, which is rated before billing, in the **Transaction Leg Information** zone.

### Related Topics

For more information on...	See...
How to view characteristics of a calculation line	<a href="#">Viewing Characteristics of a Calculation Line</a> on page 960

## Searching for a Transaction Feed

### Procedure

To search for a transaction feed:

1. Click the **Menu** link in the **Application** toolbar.  
A list appears.
2. From the **Main** menu, select **Transaction Feed Management** and then click **Feed Management Dashboard**.  
The **Feed Management Dashboard** screen appears.
3. Enter the search criteria in the **Search — Feed Level** zone.

**Note:** ORMB search engine supports wildcard search, where you can substitute the percentage (%) symbol as a stand in for any word or letter in a search criteria. You can use the ‘%’ wildcard character in all input fields except the date and ID fields. The ‘%’ wildcard character is suffixed automatically at the end of the partial search criteria. Therefore, you may or may not specify the wildcard character at the end of the partial search criteria. However, you have to prefix the wildcard character manually wherever required.

4. Click **Search**.

A list of transaction feeds that meet the search criteria appears in the **Search Results** section.

### Related Topics

For more information on...	See...
<b>Feed Management Dashboard</b> screen	<a href="#">Feed Management Dashboard</a> on page 950
<b>Search — Feed Level</b> zone	<a href="#">Search - Feed Level</a> on page 950

## Viewing Division Level Details of a Transaction Feed

### Procedure

To view the division level details of a transaction feed:

1. Search for the transaction feed in the **Feed Management Dashboard** screen.
2. In the **Search Results** section, click the **Broadcast**  icon corresponding to the transaction feed whose division level details you want to view.

The **Division Level Information** zone appears.

3. View the transaction volume details of each division in the **Division Level Information** zone.

### Related Topics

For more information on...	See...
How to search for a transaction feed	<a href="#">Searching for a Transaction Feed</a> on page 957
<b>Division Level Information</b> zone	<a href="#">Division Level Information</a> on page 952

## Viewing Transactions that Belong to a Division

### Procedure

To view the transactions that belong to a division:

1. Search for the transaction feed in the **Feed Management Dashboard** screen.
2. In the **Search Results** section, click the **Broadcast**  icon corresponding to the transaction feed whose details you want to view.

The **Division Level Information** zone appears.

3. Click the **Broadcast**  icon corresponding to the division whose transaction details you want to view.

The **Transaction Level Information** zone appears.

4. View the list of the transactions that belong to the division in the **Transaction Level Information** zone.



### Related Topics

For more information on...	See...
How to search for a transaction feed	<a href="#">Searching for a Transaction Feed</a> on page 957
<b>Division Level Information</b> zone	<a href="#">Division Level Information</a> on page 952
<b>Transaction Level Information</b> zone	<a href="#">Transaction Level Information</a> on page 953

## Viewing Legs of a Transaction

### Procedure

To view the legs of a transaction:

1. Search for the transaction feed in the **Feed Management Dashboard** screen.
2. In the **Search Results** section, click the **Broadcast**  icon corresponding to the transaction feed whose details you want to view.  
The **Division Level Information** zone appears.
3. Click the **Broadcast**  icon corresponding to the division whose transactions you want to view.  
The **Transaction Level Information** zone appears.
4. Click the **Broadcast**  icon corresponding to the transaction whose legs you want to view.  
The **Transaction Leg Information** zone appears.
5. View the details of transaction legs in the **Transaction Leg Information** zone.





#### Related Topics

For more information on...	See...
How to search for a transaction feed	<a href="#">Searching for a Transaction Feed</a> on page 957
<b>Division Level Information</b> zone	<a href="#">Division Level Information</a> on page 952
<b>Transaction Level Information</b> zone	<a href="#">Transaction Level Information</a> on page 953
<b>Transaction Leg Information</b> zone	<a href="#">Transaction Leg Information</a> on page 954

## Viewing the SQIs Calculated for a Transaction Leg

#### Procedure

To view the SQIs calculated for a transaction leg:

1. Search for the transaction feed in the **Feed Management Dashboard** screen.
2. In the **Search Results** section, click the **Broadcast**  icon corresponding to the transaction feed whose details you want to view.  
The **Division Level Information** zone appears.
3. Click the **Broadcast**  icon corresponding to the division whose transactions you want to view.  
The **Transaction Level Information** zone appears.
4. Click the **Broadcast**  icon corresponding to the transaction whose legs you want to view.  
The **Transaction Leg Information** zone appears.
5. Click the **Broadcast**  icon corresponding to the transaction leg (which is rated before billing) whose SQIs you want to view.  
The **Transaction Leg Service Quantity**, **Transaction Leg Calculation Lines**, and **Transaction Leg Calc Line Characteristics** zones appear.
6. View the SQIs calculated for the transaction leg in the **Transaction Leg Service Quantity** zone.

#### Related Topics

For more information on...	See...
How to search for a transaction feed	<a href="#">Searching for a Transaction Feed</a> on page 957
<b>Division Level Information</b> zone	<a href="#">Division Level Information</a> on page 952

For more information on...	See...
Transaction Level Information zone	<a href="#">Transaction Level Information</a> on page 953
Transaction Leg Information zone	<a href="#">Transaction Leg Information</a> on page 954
Transaction Leg Service Quantity zone	<a href="#">Transaction Leg Service Quantity</a> on page 955

## Viewing the Calculation Lines of a Transaction Leg

### Procedure

To view the calculation lines of a transaction leg:

1. Search for the transaction feed in the **Feed Management Dashboard** screen.
2. In the **Search Results** section, click the **Broadcast**  icon corresponding to the transaction feed whose details you want to view.

The **Division Level Information** zone appears.

3. Click the **Broadcast**  icon corresponding to the division whose transactions you want to view.

The **Transaction Level Information** zone appears.

4. Click the **Broadcast**  icon corresponding to the transaction whose legs you want to view.

The **Transaction Leg Information** zone appears.

5. Click the **Broadcast**  icon corresponding to the transaction leg (which is rated before billing) whose calculation lines you want to view.

The **Transaction Leg Service Quantity**, **Transaction Leg Calculation Lines**, and **Transaction Leg Calc Line Characteristics** zones appear.

6. View the list of calculation lines generated for the transaction leg in the **Transaction Leg Calculation Lines** zone.

### Related Topics

For more information on...	See...
How to search for a transaction feed	<a href="#">Searching for a Transaction Feed</a> on page 957
Division Level Information zone	<a href="#">Division Level Information</a> on page 952
Transaction Level Information zone	<a href="#">Transaction Level Information</a> on page 953
Transaction Leg Information zone	<a href="#">Transaction Leg Information</a> on page 954
Transaction Leg Calculation Lines zone	<a href="#">Transaction Leg Calculation Lines</a> on page 955

## Viewing Characteristics of a Calculation Line



### Procedure

To view the characteristics of a calculation line:

1. Search for the transaction feed in the **Feed Management Dashboard** screen.
2. In the **Search Results** section, click the **Broadcast**  icon corresponding to the transaction feed whose details you want to view.

The **Division Level Information** zone appears.



3. Click the **Broadcast**  icon corresponding to the division whose transactions you want to view.  
The **Transaction Level Information** zone appears.
4. Click the **Broadcast**  icon corresponding to the transaction whose legs you want to view.  
The **Transaction Leg Information** zone appears.
5. Click the **Broadcast**  icon corresponding to the transaction leg (which is rated before billing) whose calculation lines you want to view.  
The **Transaction Leg Service Quantity**, **Transaction Leg Calculation Lines**, and **Transaction Leg Calc Line Characteristics** zones appear.
6. View the characteristics of each calculation line in the **Transaction Leg Calc Line Characteristics** zone.

### Related Topics

For more information on...	See...
How to search for a transaction feed	<a href="#">Searching for a Transaction Feed</a> on page 957
<b>Division Level Information</b> zone	<a href="#">Division Level Information</a> on page 952
<b>Transaction Level Information</b> zone	<a href="#">Transaction Level Information</a> on page 953
<b>Transaction Leg Information</b> zone	<a href="#">Transaction Leg Information</a> on page 954
<b>Transaction Leg Calc Line Characteristics</b> zone	<a href="#">Transaction Leg Calc Line Characteristics</a> on page 957

## View Billed Transactions

The **View Billed Transactions** screen allows you to view the transactions which are billed to the person. This screen consists of the following zones:

- [Search Bill](#) on page 961
- [Bill Segments](#) on page 963
- [Transaction Details](#) on page 964
- [SQ Details](#) on page 965

You can also access this screen from the **Bill** screen by selecting the **Go To View Billed Transactions** option from the **Bill ID** context menu. The only difference is that the **Search Bill** zone does not appear when you access this screen from the **Bill** screen.

## Search Bill

The **Search Bill** zone allows you to search for a bill. This zone contains the following two sections:

- **Search Criteria** — The **Search Criteria** section contains the following fields:

Field Name	Field Description	Mandatory (Yes or No)
Person ID	Used to search bills of a particular person.  <b>Note:</b> The <b>Search</b>  icon appears corresponding to this field. On clicking the <b>Search</b> icon, the <b>Person Search</b> window appears.	No

Field Name	Field Description	Mandatory (Yes or No)
Bill ID	Used to search a particular bill.  <b>Note:</b> The <b>Search</b> (  ) icon appears corresponding to this field. On clicking the <b>Search</b> icon, the <b>Bill Search</b> window appears.	No
Alternate Bill ID	Used to search a particular bill using the alternate bill ID.	No
Division	Used to search bills of accounts that belong to a particular division.  <b>Note:</b> You can only view those divisions to which you have access in the <b>Division</b> list.	Yes (Conditional)  <b>Note:</b> This field is not required when you search for a bill using the Bill ID or the Alternate Bill ID.
Primary Account Identifier Type	Used to select the identifier type based on which you want to search bills of a particular account.	Yes (Conditional)  <b>Note:</b> If you enter the account identifier as a search criteria, you have to select the account identifier type.
Primary Account Identifier	Used when you want search bills of a particular account.	Yes (Conditional)  <b>Note:</b> If you specify the account identifier type as a search criteria, you have to enter the account identifier.
Primary Person Identifier Type	Used to select the identifier type based on which you want to search bills of a particular person.	Yes (Conditional)  <b>Note:</b> If you enter the person identifier as a search criteria, you have to select the person identifier type.
Primary Person Identifier	Used when you want search bills of a particular person.	Yes (Conditional)  <b>Note:</b> If you specify the person identifier type as a search criteria, you have to enter the person identifier.
Bill Completion From Date	Used to search bills which are completed on or later than the specified date.	No
Bill Completion To Date	Used to search bills which are completed on or earlier than the specified date.	No

Field Name	Field Description	Mandatory (Yes or No)
Bill Status	Used to search bills with a particular status. The valid values are: <ul style="list-style-type: none"> <li>Complete</li> <li>Pending</li> </ul>	No

- **Search Results** — On clicking the **Search** button, the search results appear based on the specified search criteria. The **Search Results** section contains the following columns:

Column Name	Column Description
Bill ID	Displays the bill ID. <b>Note:</b> It has a link. On clicking the link, the <b>Bill</b> screen appears with the details of the respective bill.
Bill Status	Displays the status of the bill.
Completion Date	Displays the date when the bill was completed.
Total Bill Amount	Displays the total amount billed to the person.
Invoice Currency	Displays the currency in which the amount is billed to the person.
Account Identifier Type	Displays the primary account identifier type.
Account Identifier	Indicates the account for which the bill is created.
Person Identifier Type	Displays the primary person identifier type.
Person Identifier	Indicates the person for whom the bill is created.
Division	Displays the division to which the account belongs.
Alternate Bill ID	Displays the alternate bill ID.

### Related Topics

For more information on...	See...
How to search for a bill	<a href="#">Searching for a Bill</a> on page 965
How to view the bill segments of a bill	<a href="#">Viewing the Bill Segments of a Bill</a> on page 966
How to view the transactions for which a bill segment is generated in a bill	<a href="#">Viewing Transactions for which the Bill Segment is Generated</a> on page 966

### Bill Segments

The **Bill Segments** zone lists the bill segments of a bill. This zone contains the following columns:

Column Name	Column Description
Bill Segment ID	Displays the bill segment ID. <b>Note:</b> It has a link. On clicking the link, the <b>Bill Segment</b> screen appears with the details of the respective bill segment.
Status	Indicates the status of the bill segment.

Column Name	Column Description
Start Date	Displays the start date of the bill segment.
End Date	Displays the end date of the bill segment.
Amount	Displays the amount of the bill segment.
Currency	Indicates the currency in which the bill segment is generated.
Price Item	Indicates the price item for which the bill segment is generated.
Variance Parameter	Indicates the variance parameter which is used along with the price item for determining price item pricing.  <b>Note:</b> This column appears only when the <b>Multi Price Parameter</b> option type of the <b>Multi Parameter Based Pricing (C1_PPARM_FLG)</b> feature configuration is set to <b>False</b> .
Price Item Parameters	Displays a comma-separated list of parameter values. It indicates the price item parameters and their values which are used along with the price item for determining price item pricing.  <b>Note:</b> This column appears only when the <b>Multi Price Parameter</b> option type of the <b>Multi Parameter Based Pricing (C1_PPARM_FLG)</b> feature configuration is set to <b>True</b> .
Rate Schedule	Indicates the rate schedule which is used for defining the price item pricing.
Billable Charge ID	Indicates the billable charge for which the bill segment is generated.  <b>Note:</b> It has a link. On clicking the link, the <b>Billable Charge</b> screen appears where you can view the details of the respective billable charge.
Account Information	Indicates the member account (in the invoicing group) for which the bill segment is generated.
Invoice Construct ID	Indicates the construct through which the bill segment is generated.

By default, the **Bill Segments** zone does not appear in the **View Billed Transactions** screen. It appears only when you click the **Broadcast**  icon corresponding to the bill in the **Search** zone.

### Related Topics

For more information on...	See...
How to view the bill segments of a bill	<a href="#">Viewing the Bill Segments of a Bill</a> on page 966

## Transaction Details

The **Transaction Details** zone lists the transactions for which the billable charge (corresponding to the bill segment) is created. This zone contains the following columns:

Column Name	Column Description
Transaction ID	Displays the transaction ID.  <b>Note:</b> It has a link. On clicking the link, the <b>Transaction Details</b> screen appears with the details of the respective transaction.
Transaction Date	Displays the date when the transaction was performed.
Transaction Volume	Displays the transaction volume.

Column Name	Column Description
Transaction Amount	Displays the transaction amount.
Transaction Source	Displays the transaction source from where the transaction was received.
Transaction Record Type	Displays the record type of the transaction.
Initial Price Item	Indicates the price item to which the transaction is mapped.
Rule	Indicates the rule which was met while determining initial price item for the transaction. <b>Note:</b> It has a link. On clicking the link, the <b>Rule</b> screen appears where you can view the details of the rule.
Transaction Information	Displays additional information about the transaction. <b>Note:</b> It has a link. On clicking the link, the <b>Transaction Details</b> screen appears where you can view the details of the transaction.

By default, the **Transaction Details** zone does not appear in the **View Billed Transactions** screen. It appears only when you click the **Broadcast**  icon corresponding to the bill segment in the **Bill Segments** zone.

#### **Related Topics**

For more information on...	See...
How to view the transactions for which a bill segment is generated in a bill	<a href="#">Viewing Transactions for which the Bill Segment is Generated</a> on page 966

## **SQ Details**

The **SQ Details** zone lists the SQIs calculated on the billable charge (corresponding to the bill segment). This zone contains the following columns:

Column Name	Column Description
SQI	Indicates the service quantity identifier.
Billable Service Quantity	Displays the SQI value used by the rates engine for calculation.

By default, the **SQ Details** zone does not appear in the **View Billed Transactions** screen. It appears only when you click the **Broadcast**  icon corresponding to the bill segment in the **Bill Segments** zone.

#### **Related Topics**

For more information on...	See...
How to view the SQIs calculated on the billable charge	<a href="#">Viewing SQIs Calculated on the Billable Charge</a> on page 967

## **Searching for a Bill**

### **Procedure**

To search for a bill:

1. Click the **Menu** link in the **Application** toolbar.

A list appears.

- From the **Main** menu, select **Transaction Feed Management** and then click **View Billed Transactions**.

The **View Billed Transactions** screen appears.

- Enter the search criteria in the **Search Bill** zone.

**Note:** ORMB search engine supports wildcard search, where you can substitute the percentage (%) symbol as a stand in for any word or letter in a search criteria. You can use the ‘%’ wildcard character in all input fields except the date and ID fields. The ‘%’ wildcard character is suffixed automatically at the end of the partial search criteria. Therefore, you may or may not specify the wildcard character at the end of the partial search criteria. However, you have to prefix the wildcard character manually wherever required.

- Click **Search**.

A list of bills that meet the search criteria appears in the **Search Results** section.

#### Related Topics

For more information on...	See...
<b>View Billed Transactions</b> screen	<a href="#">View Billed Transactions</a> on page 961
<b>Search Bill</b> zone	<a href="#">Search Bill</a> on page 961

## Viewing the Bill Segments of a Bill

### Procedure

To view the bill segments of a bill:

- Search for the bill in the **View Billed Transactions** screen.
- In the **Search Results** section, click the **Broadcast**  icon corresponding to the bill whose bill segments you want to view.

The **Bill Segments** zone appears.

- View all bill segments of the bill in the **Bill Segments** zone.

### Related Topics

For more information on...	See...
How to search for a bill	<a href="#">Searching for a Bill</a> on page 965
<b>Bill Segments</b> zone	<a href="#">Bill Segments</a> on page 963

## Viewing Transactions for which the Bill Segment is Generated

### Procedure

To view transactions for which the bill segment is generated:

- Search for the bill in the **View Billed Transactions** screen.
- In the **Search Results** section, click the **Broadcast**  icon corresponding to the bill whose bill segments you want to view.

The **Bill Segments** zone appears.

- Click the **Broadcast**  icon corresponding to the bill segment whose details you want to view.  
The **Transaction Details** zone appears.
- View the list of transactions for which the billable charge (corresponding to the bill segment) is created.



### Related Topics

For more information on...	See...
How to search for a bill	<a href="#">Searching for a Bill</a> on page 965
<b>Bill Segments</b> zone	<a href="#">Bill Segments</a> on page 963
<b>Transaction Details</b> zone	<a href="#">Transaction Details</a> on page 964

## Viewing SQIs Calculated on the Billable Charge

### Procedure

To view the SQIs calculated on the billable charge:

- Search for the bill in the **View Billed Transactions** screen.
- In the **Search Results** section, click the **Broadcast**  icon corresponding to the bill whose bill segments you want to view.  
The **Bill Segments** zone appears.
- Click the **Broadcast**  icon corresponding to the bill segment whose billable charge details you want to view.  
The **SQ Details** zone appears.
- View the SQIs calculated on the billable charge in the **SQ Details** zone.

### Related Topics

For more information on...	See...
How to search for a bill	<a href="#">Searching for a Bill</a> on page 965
<b>Bill Segments</b> zone	<a href="#">Bill Segments</a> on page 963
<b>SQ Details</b> zone	<a href="#">SQ Details</a> on page 965

## Transaction Details

---

The **Transaction Details** screen allows you to search for transactions using various search criteria. It also allows you to add and copy a transaction. This screen consists of the following zones:

- [Search](#) on page 967

### Search

The **Search** zone allows you to search for transactions using various search criteria. This zone contains the following two sections:

- **Search Criteria** — The fields in the **Search Criteria** section change depending on the query option selected. You can select either of the following query options:
  - **Uploaded** — Used to indicate that you want to search for a transaction which is recently uploaded in the system.
  - **Initial Price Item Determined** — Used to indicate that you want to search for a transaction for which a price item is determined in the system.
  - **Ignored** — Used to indicate that you want to search for a transaction which is ignored in the system.
  - **Error** — Used to indicate that you want to search for a transaction which could not pass through the validation, price item determination, or billable charge creation process.
  - **Cancelled** — Used to indicate that you want to search for a transaction which is cancelled in the system.
  - **Completed** — Used to indicate that you want to search for a transaction for which billable charge is completed in the system.
  - **Invalid** — Used to indicate that you want to search for a transaction which is invalid.
- **Search Results** — The **Search Results** section displays the records based on the specified search criteria. The columns in the search results change depending on the query option selected.

You can also add a transaction manually by clicking the **Add** link in the upper right corner of this zone.

### **Related Topics**

<b>For more information on...</b>	<b>See...</b>
How to search for an uploaded transaction	<a href="#">Searching for an UPLD Transaction</a> on page 968
How to search for a transaction for which price item is determined	<a href="#">Searching for an INPD Transaction</a> on page 971
How to search for an ignored transaction	<a href="#">Searching for an IGNR Transaction</a> on page 979
How to search for an invalid transaction	<a href="#">Searching for an INVL Transaction</a> on page 982
How to search for a transaction with an error	<a href="#">Searching for an EROR Transaction</a> on page 977
How to search for a cancelled transaction	<a href="#">Searching for an CNCL Transaction</a> on page 975
How to search for a transaction for which billable charge is completed	<a href="#">Searching for an COMP Transaction</a> on page 973
How to add a transaction manually	<a href="#">Adding a Transaction</a> on page 988
How to view the details of a transaction	<a href="#">Viewing the Transaction Details</a> on page 986

## **Searching for an UPLD Transaction**

### **Procedure**

To search for an uploaded transaction:

1. Click the **Menu** link in the **Application** toolbar.  
A list appears.
2. From the **Main** menu, select **Transaction Feed Management** and then click **Transaction Details**.  
The **Transaction Details** screen appears.



3. Select the **Uploaded** option from the **Search By** list to indicate that you want to search for a transaction which is recently uploaded in the system.

The **Search Criteria** section contains the following fields:

Field Name	Field Description	Mandatory (Yes or No)
External Reference Number	Used to search a transaction with a particular external reference number.	No
Division	Used to search transactions that belong to a particular division.  <b>Note:</b> You can only view those divisions to which you have access in the <b>Division</b> list.	No
Transaction Source	Used to search transactions received from a particular transaction source.	No
Transaction Record Type	Used to search transactions with a particular record type.	No
Account Identifier Type	Used to select the identifier type based on which you want to search transactions of an account.	No
Account Identifier	Used to search transactions which are performed for a particular account.	No
Transaction Date	Used to search transactions which are performed on a particular date.	No
Transaction Upload Date	Used to search transactions which are uploaded in the system on a particular date.	No
Transaction Header ID	Used to search transactions which are uploaded through a particular transaction feed.	No
Disaggregated	Used to indicate whether you want to search transactions which were disaggregated. The valid values are: <ul style="list-style-type: none"> <li>• Yes</li> <li>• No</li> </ul>	No

4. Enter the search criteria in the **Search** zone.

**Note:** ORMB search engine supports wildcard search, where you can substitute the percentage (%) symbol as a stand in for any word or letter in a search criteria. You can use the ‘%’ wildcard character in all input fields except the date and ID fields. The ‘%’ wildcard character is suffixed automatically at the end of the partial search criteria. Therefore, you may or may not specify the wildcard character at the end of the partial search criteria. However, you have to prefix the wildcard character manually wherever required.

5. Click **Search**.

A list of transactions that meet the search criteria appears in the **Search Results** section. It contains the following columns:

Column Name	Column Description
Transaction ID	Displays the transaction ID. <b>Note:</b> It has a link. On clicking the link, the <b>Transaction Details</b> screen appears with the details of the respective transaction.
Transaction Source	Displays the transaction source from where the transaction was received.
Transaction Record Type	Displays the record type of the transaction.
Transaction Upload Date	Displays the date when the transaction was uploaded in the system.
Transaction Header ID	Indicates the transaction feed through which the transaction was uploaded in the system.
External Reference Number	Displays the external reference number of the transaction.
Disaggregation Status	Indicates whether the transaction was disaggregated. The valid values are: <ul style="list-style-type: none"> <li>• Yes</li> <li>• No</li> </ul>
Manual Entry	Indicates whether the transaction is manually added in the system. The valid values are: <ul style="list-style-type: none"> <li>• Yes</li> <li>• No</li> </ul>
Transaction Date	Displays the date when the transaction was performed.
Transaction Amount	Displays the transaction amount.
Transaction Volume	Displays the transaction volume.
Division	Indicates the division to which the transaction belongs.
Account Information	Indicates the account for which the transaction was performed. The string includes the account identifier type and account identifier.
Transaction Information	Displays additional information about the transaction. <b>Note:</b> It has a link. On clicking the link, the <b>Transaction Details</b> screen appears where you can view the details of the transaction.

6. View the legs of the transaction in the **Transaction Legs** zone, if required.

**Note:** You can only view the legs of an uploaded transaction which is partially disaggregated.

### Related Topics

For more information on...	See...
<b>Transaction Details</b> screen	<a href="#">Transaction Details</a> on page 967
<b>Search</b> zone	<a href="#">Search</a> on page 967
How to view the legs of a transaction	<a href="#">Viewing the Transaction Legs</a> on page 984

## Searching for an INPD Transaction

### Procedure

To search for a transaction for which a price item is determined:

1. Click the **Menu** link in the **Application** toolbar.

A list appears.

2. From the **Main** menu, select **Transaction Feed Management** and then click **Transaction Details**.

The **Transaction Details** screen appears.

3. Select the **Initial Price Item Determined** option from the **Search By** list to indicate that you want to search for a transaction for which a price item is determined in the system.

The **Search Criteria** section contains the following fields:

Field Name	Field Description	Mandatory (Yes or No)
External Reference Number	Used to search a transaction with a particular external reference number.	No
Division	Used to search transactions that belong to a particular division.  <b>Note:</b> You can only view those divisions to which you have access in the <b>Division</b> list.	No
Transaction Source	Used to search transactions received from a particular transaction source.	No
Transaction Record Type	Used to search transactions with a particular record type.	No
Account Identifier Type	Used to select the identifier type based on which you want to search transactions of an account.	No
Account Identifier	Used to search transactions which are performed for a particular account.	No
Transaction Date	Used to search transactions which are performed on a particular date.	No
Transaction Upload Date	Used to search transactions which are uploaded in the system on a particular date.	No
Price Item	Used to search transactions which are mapped to a particular price item.	No
Disaggregated	Used to indicate whether you want to search transactions which were disaggregated. The valid values are: <ul style="list-style-type: none"> <li>• Yes</li> <li>• No</li> </ul>	No

4. Enter the search criteria in the **Search** zone.

**Note:** ORMB search engine supports wildcard search, where you can substitute the percentage (%) symbol as a stand in for any word or letter in a search criteria. You can use the ‘%’ wildcard character in all the input fields except the date fields. The ‘%’ wildcard character is suffixed automatically at the end of the partial search criteria. Therefore, you may or may not specify the wildcard character at the end of the partial search criteria. However, you have to prefix the wildcard character manually wherever required.

##### 5. Click **Search**.

A list of transactions that meet the search criteria appears in the search results. The **Search Results** section contains the following columns:

Column Name	Column Description
Transaction ID	Displays the transaction ID. <b>Note:</b> It has a link. On clicking the link, the <b>Transaction Details</b> screen appears with the details of the respective transaction.
Transaction Source	Displays the transaction source from where the transaction was received.
Transaction Record Type	Displays the record type of the transaction.
Transaction Upload Date	Displays the date when the transaction was uploaded in the system.
External Reference Number	Displays the external reference number of the transaction.
Transaction Date	Displays the date when the transaction was performed.
Disaggregation Status	Indicates whether the transaction was disaggregated. The valid values are: <ul style="list-style-type: none"> <li>• Yes</li> <li>• No</li> </ul>
Transaction Amount	Displays the transaction amount.
Transaction Volume	Displays the transaction volume.
Division	Indicates the division to which the transaction belongs.
Account Information	Indicates the account for which the transaction was performed. The string includes the account identifier type and account identifier.
Rule	Indicates the rule which was met while determining initial price item for the transaction. <b>Note:</b> It has a link. On clicking the link, the <b>Rule</b> screen appears where you can view the details of the rule.
Transaction Information	Displays additional information about the transaction. <b>Note:</b> It has a link. On clicking the link, the <b>Transaction Details</b> screen appears where you can view the details of the transaction.

##### 6. View the legs of the transaction in the **Transaction Legs** zone, if required.

#### Related Topics

For more information on...	See...
<b>Transaction Details</b> screen	<a href="#">Transaction Details</a> on page 967

For more information on...	See...
Search zone	<a href="#">Search</a> on page 967
How to view the legs of a transaction	<a href="#">Viewing the Transaction Legs</a> on page 984

## Searching for an COMP Transaction

### **Procedure**

To search for a transaction for which billable charge is completed:

1. Click the **Menu** link in the **Application** toolbar.  
A list appears.
2. From the **Main** menu, select **Transaction Feed Management** and then click **Transaction Details**.  
The **Transaction Details** screen appears.
3. Select the **Completed** option from the **Search By** list to indicate that you want to search for a transaction for which billable charge is completed in the system.

The **Search Criteria** section contains the following fields:

Field Name	Field Description	Mandatory (Yes or No)
External Reference Number	Used to search a transaction with a particular external reference number.	No
Division	Used to search transactions that belong to a particular division. <b>Note:</b> You can only view those divisions to which you have access in the <b>Division</b> list.	No
Transaction Source	Used to search transactions received from a particular transaction source.	No
Transaction Record Type	Used to search transactions with a particular record type.	No
Account Identifier Type	Used to select the identifier type based on which you want to search transactions of an account.	No
Account Identifier	Used to search transactions which are performed for a particular account.	No
Transaction Date	Used to search transactions which are performed on a particular date.	No
Transaction Upload Date	Used to search transactions which are uploaded in the system on a particular date.	No
Billable Charge ID	Used to search transactions which are included in a particular billable charge.	No

Field Name	Field Description	Mandatory (Yes or No)
Disaggregated	Used to indicate whether you want to search transactions which were disaggregated. The valid values are: <ul style="list-style-type: none"> <li>• Yes</li> <li>• No</li> </ul>	No

4. Enter the search criteria in the **Search** zone.

**Note:** ORMB search engine supports wildcard search, where you can substitute the percentage (%) symbol as a stand in for any word or letter in a search criteria. You can use the ‘%’ wildcard character in all input fields except the date and ID fields. The ‘%’ wildcard character is suffixed automatically at the end of the partial search criteria. Therefore, you may or may not specify the wildcard character at the end of the partial search criteria. However, you have to prefix the wildcard character manually wherever required.

5. Click **Search**.

A list of transactions that meet the search criteria appears in the search results. The **Search Results** section contains the following columns:

Column Name	Column Description
Transaction ID	Displays the transaction ID. <b>Note:</b> It has a link. On clicking the link, the <b>Transaction Details</b> screen appears with the details of the respective transaction.
Transaction Source	Displays the transaction source from where the transaction was received.
Transaction Record Type	Displays the record type of the transaction.
External Reference Number	Displays the external reference number of the transaction.
Disaggregation Status	Indicates whether the transaction was disaggregated. The valid values are: <ul style="list-style-type: none"> <li>• Yes</li> <li>• No</li> </ul>
Transaction Date	Displays the date when the transaction was performed.
Transaction Amount	Displays the transaction amount.
Transaction Volume	Displays the transaction volume.
Division	Indicates the division to which the transaction belongs.
Account Information	Indicates the account for which the transaction was performed. The string includes the account identifier type and account identifier.
Rule	Indicates the rule which was met while determining initial price item for the transaction. <b>Note:</b> It has a link. On clicking the link, the <b>Rule</b> screen appears where you can view the details of the rule.

Column Name	Column Description
Transaction Information	Displays additional information about the transaction.  <b>Note:</b> It has a link. On clicking the link, the <b>Transaction Details</b> screen appears where you can view the details of the transaction.

6. View the legs of the transaction in the **Transaction Legs** zone, if required.

### Related Topics

For more information on...	See...
<b>Transaction Details</b> screen	<a href="#">Transaction Details</a> on page 967
<b>Search</b> zone	<a href="#">Search</a> on page 967
How to view the legs of a transaction	<a href="#">Viewing the Transaction Legs</a> on page 984

## Searching for an CNCL Transaction

### Procedure

To search for a cancelled transaction:

- Click the **Menu** link in the **Application** toolbar.  
A list appears.
- From the **Main** menu, select **Transaction Feed Management** and then click **Transaction Details**.  
The **Transaction Details** screen appears.
- Select the **Cancelled** option from the **Search By** list to indicate that you want to search for a transaction which is cancelled in the system.

The **Search Criteria** section contains the following fields:

Field Name	Field Description	Mandatory (Yes or No)
External Reference Number	Used to search a transaction with a particular external reference number.	No
Division	Used to search transactions that belong to a particular division.  <b>Note:</b> You can only view those divisions to which you have access in the <b>Division</b> list.	No
Transaction Source	Used to search transactions received from a particular transaction source.	No
Transaction Record Type	Used to search transactions with a particular record type.	No
Account Identifier Type	Used to select the identifier type based on which you want to search transactions of an account.	No
Account Identifier	Used to search transactions which are performed for a particular account.	No

Field Name	Field Description	Mandatory (Yes or No)
Transaction Date	Used to search transactions which are performed on a particular date.	No
Transaction Upload Date	Used to search transactions which are uploaded in the system on a particular date.	No
Transaction Header ID	Used to search transactions which are uploaded through a particular transaction feed.	No
Disaggregated	Used to indicate whether you want to search transactions which were disaggregated. The valid values are: <ul style="list-style-type: none"> <li>• Yes</li> <li>• No</li> </ul>	No

4. Enter the search criteria in the **Search** zone.

**Note:** ORMB search engine supports wildcard search, where you can substitute the percentage (%) symbol as a stand in for any word or letter in a search criteria. You can use the ‘%’ wildcard character in all input fields except the date and ID fields. The ‘%’ wildcard character is suffixed automatically at the end of the partial search criteria. Therefore, you may or may not specify the wildcard character at the end of the partial search criteria. However, you have to prefix the wildcard character manually wherever required.

5. Click **Search**.

A list of transactions that meet the search criteria appears in the search results. The **Search Results** section contains the following columns:

Column Name	Column Description
Transaction ID	Displays the transaction ID. <b>Note:</b> It has a link. On clicking the link, the <b>Transaction Details</b> screen appears with the details of the respective transaction.
Transaction Source	Displays the transaction source from where the transaction was received.
Transaction Record Type	Displays the record type of the transaction.
Transaction Upload Date	Displays the date when the transaction was uploaded in the system.
Transaction Header ID	Indicates the transaction feed through which the transaction was uploaded in the system.
External Reference Number	Displays the external reference number of the transaction.
Disaggregation Status	Indicates whether the transaction was disaggregated. The valid values are: <ul style="list-style-type: none"> <li>• Yes</li> <li>• No</li> </ul>
Manual Entry	Indicates whether the transaction is manually added in the system. The valid values are: <ul style="list-style-type: none"> <li>• Yes</li> <li>• No</li> </ul>
Transaction Date	Displays the date when the transaction was performed.



Column Name	Column Description
Transaction Amount	Displays the transaction amount.
Transaction Volume	Displays the transaction volume.
Division	Indicates the division to which the transaction belongs.
Account Information	Indicates the account for which the transaction was performed. The string includes the account identifier type and account identifier.
Transaction Information	Displays additional information about the transaction.  <b>Note:</b> It has a link. On clicking the link, the <b>Transaction Details</b> screen appears where you can view the details of the transaction.

### Related Topics

For more information on...	See...
<b>Transaction Details</b> screen	<a href="#">Transaction Details</a> on page 967
<b>Search</b> zone	<a href="#">Search</a> on page 967

## Searching for an EROR Transaction

### Procedure

To search for a transaction with an error:

1. Click the **Menu** link in the **Application** toolbar.  
A list appears.
2. From the **Main** menu, select **Transaction Feed Management** and then click **Transaction Details**.  
The **Transaction Details** screen appears.
3. Select the **Error** option from the **Search By** list to indicate that you want to search for a transaction which could not pass through the validation, price item determination, or billable charge creation process.

The **Search Criteria** section contains the following fields:

Field Name	Field Description	Mandatory (Yes or No)
External Reference Number	Used to search a transaction with a particular external reference number.	No
Division	Used to search transactions that belong to a particular division.  <b>Note:</b> You can only view those divisions to which you have access in the <b>Division</b> list.	No
Transaction Source	Used to search transactions received from a particular transaction source.	No
Transaction Record Type	Used to search transactions with a particular record type.	No

Field Name	Field Description	Mandatory (Yes or No)
Account Identifier Type	Used to select the identifier type based on which you want to search transactions of an account.	No
Account Identifier	Used to search transactions which are performed for a particular account.	No
Transaction Date	Used to search transactions which are performed on a particular date.	No
Transaction Upload Date	Used to search transactions which are uploaded in the system on a particular date.	No
Transaction Header ID	Used to search transactions which are uploaded through a particular transaction feed.	No
Disaggregated	Used to indicate whether you want to search transactions which were disaggregated. The valid values are: <ul style="list-style-type: none"> <li>• Yes</li> <li>• No</li> </ul>	No

4. Enter the search criteria in the **Search** zone.

**Note:** ORMB search engine supports wildcard search, where you can substitute the percentage (%) symbol as a stand in for any word or letter in a search criteria. You can use the ‘%’ wildcard character in all input fields except the date and ID fields. The ‘%’ wildcard character is suffixed automatically at the end of the partial search criteria. Therefore, you may or may not specify the wildcard character at the end of the partial search criteria. However, you have to prefix the wildcard character manually wherever required.

5. Click **Search**.

A list of transactions that meet the search criteria appears in the search results. The **Search Results** section contains the following columns:

Column Name	Column Description
Transaction ID	Displays the transaction ID. <b>Note:</b> It has a link. On clicking the link, the <b>Transaction Details</b> screen appears with the details of the respective transaction.
Transaction Source	Displays the transaction source from where the transaction was received.
Transaction Record Type	Displays the record type of the transaction.
Transaction Upload Date	Displays the date when the transaction was uploaded in the system.
External Reference Number	Displays the external reference number of the transaction.
Customer Reference Number	Indicates the person who performed the transaction.
Disaggregation Status	Indicates whether the transaction was disaggregated. The valid values are: <ul style="list-style-type: none"> <li>• Yes</li> <li>• No</li> </ul>
Transaction Date	Displays the date when the transaction was performed.

Column Name	Column Description
Transaction Amount	Displays the transaction amount.
Transaction Volume	Displays the transaction volume.
Division	Indicates the division to which the transaction belongs.
Error Message	<p>Indicates the reason why the validation and price item determination process failed.</p> <p><b>Note:</b> If the error occurred while executing the <b>Validate Transaction and Derive Price Item (C1-TXNIP)</b> batch, a generic message appears indicating that the transaction is in the <b>Error (EROR)</b> status due to one or more reasons. You can view all error messages logged for the transaction in the <b>Transaction Error Messages</b> zone. However, if the error occurred while executing the <b>Price Item Pricing Verification (C1-TXNVP)</b> or <b>Service Quantity Calculation (C1-TXNSQ)</b> batch, a generic message appears indicating that one or more transaction legs are in the <b>Error (EROR)</b> status. You can view the error message corresponding to the transaction leg in the <b>Transaction Legs</b> zone.</p>
Account Information	Indicates the account for which the transaction was performed. The string includes the account identifier type and account identifier.
Rule	<p>Indicates the rule which was met while determining initial price item for the transaction.</p> <p><b>Note:</b></p> <p>It has a link. On clicking the link, the <b>Rule</b> screen appears where you can view the details of the rule.</p> <p>This column is blank when the error has occurred while determining initial price item for the transaction.</p>
Transaction Information	<p>Displays additional information about the transaction.</p> <p><b>Note:</b> It has a link. On clicking the link, the <b>Transaction Details</b> screen appears where you can view the details of the transaction.</p>

6. View the legs of the transaction in the **Transaction Legs** zone, if required.
7. View the error messages logged for the transaction in the **Transaction Error Messages** zone, if required.

### **Related Topics**

For more information on...	See...
<b>Transaction Details</b> screen	<a href="#">Transaction Details</a> on page 967
<b>Search</b> zone	<a href="#">Search</a> on page 967
How to view the legs of a transaction	<a href="#">Viewing the Transaction Legs</a> on page 984
How to view the error messages logged for a transaction	<a href="#">Viewing Error Messages</a> on page 986

## Searching for an IGNR Transaction

**Procedure**

To search for an ignored transaction:

1. Click the **Menu** link in the **Application** toolbar.  
A list appears.
2. From the **Main** menu, select **Transaction Feed Management** and then click **Transaction Details**.  
The **Transaction Details** screen appears.
3. Select the **Ignored** option from the **Search By** list to indicate that you want to search for a transaction which is ignored in the system.

The **Search Criteria** section contains the following fields:

Field Name	Field Description	Mandatory (Yes or No)
External Reference Number	Used to search a transaction with a particular external reference number.	No
Division	Used to search transactions that belong to a particular division. <b>Note:</b> You can only view those divisions to which you have access in the <b>Division</b> list.	No
Transaction Source	Used to search transactions received from a particular transaction source.	No
Transaction Record Type	Used to search transactions with a particular record type.	No
Account Identifier Type	Used to select the identifier type based on which you want to search transactions of an account.	No
Account Identifier	Used to search transactions which are performed for a particular account.	No
Transaction Date	Used to search transactions which are performed on a particular date.	No
Transaction Upload Date	Used to search transactions which are uploaded in the system on a particular date.	No
Transaction Header ID	Used to search transactions which are uploaded through a particular transaction feed.	No
Disaggregated	Used to indicate whether you want to search transactions which were disaggregated. The valid values are: <ul style="list-style-type: none"> <li>• Yes</li> <li>• No</li> </ul>	No

4. Enter the search criteria in the **Search** zone.

**Note:** ORMB search engine supports wildcard search, where you can substitute the percentage (%) symbol as a stand in for any word or letter in a search criteria. You can use the ‘%’ wildcard character in all input fields except the date and ID fields. The ‘%’ wildcard character is suffixed automatically at the end of the partial search criteria. Therefore, you may or may not specify the wildcard character at the end of the partial search criteria. However, you have to prefix the wildcard character manually wherever required.

##### 5. Click **Search**.

A list of transactions that meet the search criteria appears in the search results. The **Search Results** section contains the following columns:

Column Name	Column Description
Transaction ID	Displays the transaction ID. <b>Note:</b> It has a link. On clicking the link, the <b>Transaction Details</b> screen appears with the details of the respective transaction.
Transaction Source	Displays the transaction source from where the transaction was received.
Transaction Record Type	Displays the record type of the transaction.
Transaction Upload Date	Displays the date when the transaction was uploaded in the system.
Transaction Header ID	Indicates the transaction feed through which the transaction was uploaded in the system.
External Reference Number	Displays the external reference number of the transaction.
Disaggregation Status	Indicates whether the transaction was disaggregated. The valid values are: <ul style="list-style-type: none"> <li>• Yes</li> <li>• No</li> </ul>
Transaction Date	Displays the date when the transaction was performed.
Transaction Amount	Displays the transaction amount.
Transaction Volume	Displays the transaction volume.
Division	Indicates the division to which the transaction belongs.
Account Information	Indicates the account for which the transaction was performed. The string includes the account identifier type and account identifier.
Rule	Indicates the rule which was met while determining initial price item for the transaction. <b>Note:</b> It has a link. On clicking the link, the <b>Rule</b> screen appears where you can view the details of the rule.
Transaction Information	Displays additional information about the transaction. <b>Note:</b> It has a link. On clicking the link, the <b>Transaction Details</b> screen appears where you can view the details of the transaction.

##### 6. View the legs of the transaction in the **Transaction Legs** zone, if required.

#### **Related Topics**

For more information on...	See...
<b>Transaction Details</b> screen	<a href="#">Transaction Details</a> on page 967
<b>Search</b> zone	<a href="#">Search</a> on page 967
How to view the legs of a transaction	<a href="#">Viewing the Transaction Legs</a> on page 984

## Searching for an INVL Transaction

### Procedure

To search for an invalid transaction:

1. Click the **Menu** link in the **Application** toolbar.  
A list appears.
2. From the **Main** menu, select **Transaction Feed Management** and then click **Transaction Details**.  
The **Transaction Details** screen appears.
3. Select the **Invalid** option from the **Search By** list to indicate that you want to search for a transaction which is invalid.

The **Search Criteria** section contains the following fields:

Field Name	Field Description	Mandatory (Yes or No)
External Reference Number	Used to search a transaction with a particular external reference number.	No
Division	Used to search transactions that belong to a particular division. <b>Note:</b> You can only view those divisions to which you have access in the <b>Division</b> list.	No
Transaction Source	Used to search transactions received from a particular transaction source.	No
Transaction Record Type	Used to search transactions with a particular record type.	No
Account Identifier Type	Used to select the identifier type based on which you want to search transactions of an account.	No
Account Identifier	Used to search transactions which are performed for a particular account.	No
Transaction Date	Used to search transactions which are performed on a particular date.	No
Transaction Upload Date	Used to search transactions which are uploaded in the system on a particular date.	No
Transaction Header ID	Used to search transactions which are uploaded through a particular transaction feed.	No

Field Name	Field Description	Mandatory (Yes or No)
Disaggregated	Used to indicate whether you want to search transactions which were disaggregated. The valid values are: <ul style="list-style-type: none"> <li>• Yes</li> <li>• No</li> </ul>	No

4. Enter the search criteria in the **Search** zone.

**Note:** ORMB search engine supports wildcard search, where you can substitute the percentage (%) symbol as a stand in for any word or letter in a search criteria. You can use the ‘%’ wildcard character in all input fields except the date and ID fields. The ‘%’ wildcard character is suffixed automatically at the end of the partial search criteria. Therefore, you may or may not specify the wildcard character at the end of the partial search criteria. However, you have to prefix the wildcard character manually wherever required.

5. Click **Search**.

A list of transactions that meet the search criteria appears in the search results. The **Search Results** section contains the following columns:

Column Name	Column Description
Transaction ID	Displays the transaction ID. <b>Note:</b> It has a link. On clicking the link, the <b>Transaction Details</b> screen appears with the details of the respective transaction.
Transaction Source	Displays the transaction source from where the transaction was received.
Transaction Record Type	Displays the record type of the transaction.
Transaction Upload Date	Displays the date when the transaction was uploaded in the system.
Transaction Header ID	Indicates the transaction feed through which the transaction was uploaded in the system.
External Reference Number	Displays the external reference number of the transaction.
Disaggregation Status	Indicates whether the transaction was disaggregated. The valid values are: <ul style="list-style-type: none"> <li>• Yes</li> <li>• No</li> </ul>
Transaction Date	Displays the date when the transaction was performed.
Transaction Amount	Displays the transaction amount.
Transaction Volume	Displays the transaction volume.
Division	Indicates the division to which the transaction belongs.
Account Information	Indicates the account for which the transaction was performed. The string includes the account identifier type and account identifier.
Transaction Information	Displays additional information about the transaction. <b>Note:</b> It has a link. On clicking the link, the <b>Transaction Details</b> screen appears where you can view the details of the transaction.

Column Name	Column Description
Error Message	Indicates the reason why the transaction is invalid.  <b>Note:</b> A generic message appears indicating that the error occurred due to one or more reasons. You can view all error messages logged for the transaction in the <b>Transaction Error Messages</b> zone.

- View the error messages logged for the transaction in the **Transaction Error Messages** zone, if required.

### Related Topics

For more information on...	See...
<b>Transaction Details</b> screen	<a href="#">Transaction Details</a> on page 967
<b>Search</b> zone	<a href="#">Search</a> on page 967
How to view the error messages logged for a transaction	<a href="#">Viewing Error Messages</a> on page 986

## Viewing the Transaction Legs

### Procedure

To view the legs of a transaction:

- Search for the transaction in the **Transaction Details** screen.
- In the **Search Results** section, click the **Broadcast**  icon corresponding to the transaction whose legs you want to view.

The **Transaction Legs** zone appears. It contains the following columns:

Column Name	Column Description
Transaction ID	Displays the transaction ID.
Transaction Leg Status	Indicates the status of the transaction leg. The valid values are: <ul style="list-style-type: none"> <li>Uploaded (UPLD)</li> <li>Initial Price Item Derived (INPD)</li> <li>Ignored (IGNR)</li> <li>Error (EROR)</li> <li>Completed (COMP)</li> </ul>
Account Information	Indicates the account which will bear the charges for the transaction. The string includes the account identifier type, account identifier, and division (to which the derived account belongs).
Initial Price Item Code	Indicates the initial price item to which the transaction is mapped.



Column Name	Column Description
Variance Parameter	Indicates the variance parameter which is used along with the final price item for determining price item pricing.  <b>Note:</b> This column appears only when the <b>Multi Price Parameter</b> option type of the <b>Multi Parameter Based Pricing (C1_PPARM_FLG)</b> feature configuration is set to <b>False</b> .
Price Item Parameters	Displays a comma-separated list of parameter values. It indicates the price item parameters and their values which are used along with the final price item for determining price item pricing.  <b>Note:</b> This column appears only when the <b>Multi Price Parameter</b> option type of the <b>Multi Parameter Based Pricing (C1_PPARM_FLG)</b> feature configuration is set to <b>True</b> .
Final Price Item Code	Indicates the final price item to which the transaction is mapped.
Rule	Indicates the rule which was met while determining initial price item for the transaction.  <b>Note:</b> It has a link. On clicking the link, the <b>Rule</b> screen appears where you can view the details of the rule.
Price Assignment ID	Indicates the effective pricing which is available for the account, price item or regular bundle (to which the price item belongs) or parent (regular) bundle (to which the regular bundle belongs) and/or variance parameter or price item parameters (parameter group) combination on the processing date.
Aggregate Transaction	Indicates whether the transaction leg is aggregated. The valid values are: <ul style="list-style-type: none"> <li>• Yes</li> <li>• No</li> </ul>
Billable Charge ID	Indicates the billable charge in which the transaction leg is included for billing.
Division	Indicates the division to which the derived account belongs. The derived account means the account which will bear the charges for the transaction.
Sequence Number	Displays the sequence number of the transaction leg.
Error Message	Indicates the reason why the price item pricing verification or billable charge creation process failed.

**Note:**

The **Broadcast**  icon appears corresponding to an UPLD, INPD, IGNR, EROR and COMP transaction. This is because you can only view legs of an UPLD, INPD, IGNR, EROR and COMP transaction.

You can only view the legs of an uploaded transaction which is partially disaggregated.

3. View the details of the transaction legs in the **Transaction Legs** zone.

**Related Topics**

For more information on...	See...
How to search for an uploaded transaction	<a href="#">Searching for an UPLD Transaction</a> on page 968

For more information on...	See...
How to search for a transaction for which price item is determined	<a href="#">Searching for an INPD Transaction</a> on page 971
How to search for an ignored transaction	<a href="#">Searching for an IGNR Transaction</a> on page 979
How to search for a transaction with an error	<a href="#">Searching for an EROR Transaction</a> on page 977
How to search for a transaction for which billable charge is completed	<a href="#">Searching for an COMP Transaction</a> on page 973

## Viewing Error Messages

### Procedure

To view the error messages logged for a transaction:

1. Search for the transaction which is in the **Invalid (INVL)** or **Error (EROR)** status in the **Transaction Details** screen.
2. In the **Search Results** section, click the **Broadcast**  icon corresponding to the transaction whose error messages you want to view.

The **Transaction Error Messages** zone appears. It contains the following columns:

Column Name	Column Description
Error Message	Indicates the reason why the transaction is in the <b>Invalid (INVL)</b> or <b>Error (EROR)</b> status.

**Note:** The **Transaction Error Messages** zone appears when the transactions are in the **Invalid (INVL)** status and when the errors occur while executing the **Validate Transaction and Derive Price Item (C1-TXNIP)** batch. It does not appear when the errors occur while executing the **Price Item Pricing Verification (C1-TXNVP)** or **Service Quantity Calculation (C1-TXNSQ)** batch.

3. View the error messages in the **Transaction Error Messages** zone.

### Related Topics

For more information on...	See...
How to search for a transaction with an error	<a href="#">Searching for an EROR Transaction</a> on page 977
How to search for an invalid transaction	<a href="#">Searching for an INVL Transaction</a> on page 982

## Viewing the Transaction Details

### Procedure

To view the details of a transaction:

1. Search for the transaction in the **Transaction Details** screen.
2. In the **Search Results** section, click the link in the **Transaction ID** column corresponding to the transaction whose details you want to view.

The **Transaction Details** screen appears. It contains the following fields:

Field Name	Field Description
Transaction ID	Displays the transaction ID. <b>Note:</b> The transaction ID is generated automatically when the transaction is uploaded or manually created in the system.
Transaction Source	Displays the transaction source from where the transaction was received.
Division	Displays the division to which the transaction belongs.
Transaction Record Type	Displays the record type of the transaction.
Transaction Date	Displays the date when the transaction was performed.
Manual Entry	Indicates whether the transaction was manually entered in the system.
Credit/Debit Indicator	Indicates whether the transaction is a debit or credit transaction.
External Reference Number	Displays the external reference number of the transaction.
Customer Reference Number	Indicates the person who performed the transaction.
Account Identifier Type	Displays the type of account identifier.
Account Identifier	Indicates the account for which the transaction was performed.
Transaction Amount	Displays the transaction amount.
Transaction Currency	Indicates the currency in which the transaction was performed.
Transaction Volume	Displays the transaction volume.
Account ID	Indicates the account for which the transaction was performed.
Additional Amount 1, Additional Amount 2, ..., Additional Amount 10 <b>Note:</b> If the business label is defined for any of these user defined fields, the business label appears instead of the field name.	Displays additional information about the transaction.
Amount 1 Currency Code, Amount 2 Currency Code, ..., Amount 10 Currency Code <b>Note:</b> If the business label is defined for any of these user defined fields, the business label appears instead of the field name.	Displays additional information about the transaction.

Field Name	Field Description
Additional Date 1, Additional Date 2, ....., Additional Date 5 <b>Note:</b> If the business label is defined for any of these user defined fields, the business label appears instead of the field name.	Displays additional information about the transaction.
Additional Numeric Data 1, Additional Numeric Data 2, Additional Numeric Data 3, ....., Additional Numeric Data 20 <b>Note:</b> If the business label is defined for any of these user defined fields, the business label appears instead of the field name.	Displays additional information about the transaction.
Additional Data 1, Additional Data 2, Additional Data 3, ....., Additional Data 50 <b>Note:</b> If the business label is defined for any of these user defined fields, the business label appears instead of the field name.	Displays additional information about the transaction.

### Related Topics

For more information on...	See...
How to copy a transaction	<a href="#">Copying a Transaction</a> on page 991

## Adding a Transaction

### Prerequisites

To add a transaction manually, you should have:

- Divisions, account identifier types, transaction sources, transaction record types, and currencies defined in the application

### Procedure

To add a transaction manually:

1. Click the **Menu** link in the **Application** toolbar.  
A list appears.
2. From the **Main** menu, select **Transaction Feed Management** and then click **Transaction Details**.  
The **Transaction Details** screen appears.
3. Click the **Add** link in the upper right corner of the **Search** zone.  
The **Transaction Details** screen appears. It contains the following fields:

Field Name	Field Description	Mandatory (Yes or No)
Transaction Source	Used to specify the transaction source from where the transaction was received.	Yes
Division	Used to specify the division to which the transaction belongs.  <b>Note:</b> You can only view those divisions to which you have access in the <b>Division</b> list.	Yes
Transaction Record Type	Used to specify the record type of the transaction.	Yes
Transaction Date	Used to specify the date when the transaction was performed.	Yes
Manual Entry	Indicates that the transaction is manually entered in the system.	Not applicable
Credit/Debit Indicator	Used to indicate whether the transaction is a debit or credit transaction.	Yes
External Reference Number	Used to specify the external reference number of the transaction.	No
Customer Reference Number	Used to indicate the person who performed the transaction.	No
Account Identifier Type	Used to specify the type of account identifier.	Yes (Conditional)  <b>Note:</b> If you enter the account identifier as a search criteria, you have to select the account identifier type.
Account Identifier	Used to indicate the account for which the transaction was performed.	Yes (Conditional)  <b>Note:</b> If you specify the account identifier type as a search criteria, you have to enter the account identifier.
Transaction Amount	Used to specify the transaction amount.	Yes
Transaction Currency	Used to indicate the currency in which the transaction was performed.	Yes
Transaction Volume	Used to specify the transaction volume.	Yes
Additional Amount 1, Additional Amount 2, ..., Additional Amount 10	Used to specify additional information about the transaction.  <b>Note:</b> These fields appear only when you select the transaction source and record type from the respective list.	Yes (Conditional)  <b>Note:</b> This field is required when you are specifying the currency in the corresponding field.
	<b>Note:</b> If the business label is defined for any of these user defined fields, the business label appears instead of the field name.	

Field Name	Field Description	Mandatory (Yes or No)
Amount 1 Currency Code, Amount 2 Currency Code, ..., Amount 10 Currency Code  <b>Note:</b> If the business label is defined for any of these user defined fields, the business label appears instead of the field name.	Used to specify additional information about the transaction.  <b>Note:</b> These fields appear only when you select the transaction source and record type from the respective list.	Yes (Conditional)  <b>Note:</b> This field is required when you are specifying the amount in the corresponding field.
Additional Date 1, Additional Date 2, ..., Additional Date 5  <b>Note:</b> If the business label is defined for any of these user defined fields, the business label appears instead of the field name.	Used to specify additional information about the transaction.  <b>Note:</b> These fields appear only when you select the transaction source and record type from the respective list.	No
Additional Numeric Data 1, Additional Numeric Data 2, Additional Numeric Data 3, ....., Additional Numeric Data 20  <b>Note:</b> If the business label is defined for any of these user defined fields, the business label appears instead of the field name.	Used to specify additional information about the transaction.  <b>Note:</b> These fields appear only when you select the transaction source and record type from the respective list.	No
Additional Data 1, Additional Data 2, Additional Data 3, ..., Additional Data 50  <b>Note:</b> If the business label is defined for any of these user defined fields, the business label appears instead of the field name.	Used to specify additional information about the transaction.  <b>Note:</b> These fields appear only when you select the transaction source and record type from the respective list.	No

4. Enter the required details.
5. Click **Save**.

The transaction is added in the system. If the following option types are set in the **Dummy Header (C1-TXNDMYID)** feature configuration, the header details including the header ID are generated automatically for the manually added transaction:

- Dummy File Name
- Dummy Header ID
- Dummy Transaction Source
- Dummy Header Date

**Note:** The header ID remains same for all transactions which are manually created on a particular date. You can cancel manually added transactions using the Transaction Header ID.

### Related Topics

For more information on...	See...
Transaction Details screen	<a href="#">Transaction Details</a> on page 967
Search zone	<a href="#">Search</a> on page 967
How to set the <b>Dummy Header (C1-TXNDMYID)</b> feature configuration	<a href="#">Setting the C1-TXNDMYID Feature Configuration</a> on page 2926

## Copying a Transaction

Instead of adding a transaction from scratch, you can create a copy of similar transaction and then edit it accordingly.

### Prerequisites

To copy a transaction, you should have:

- Transaction (whose copy you want to create) available in the application
- Divisions, account identifier types, transaction sources, transaction record types, and currencies defined in the application

### Procedure

To copy a transaction:

1. Search for the transaction in the **Transaction Details** screen.
2. In the **Search Results** section, click the link in the **Transaction ID** column corresponding to the transaction whose copy you want to create.

The **Transaction Details** screen appears. Note that the fields are in the read-only mode.

3. Click **Copy**.

The **Transaction Details** screen appears. It contains the following fields:

Field Name	Field Description	Mandatory (Yes or No)
Transaction Source	Used to specify the transaction source from where the transaction was received.	Yes
Division	Used to specify the division to which the transaction belongs.  <b>Note:</b> You can only view those divisions to which you have access in the <b>Division</b> list.	Yes
Transaction Record Type	Used to specify the record type of the transaction.	Yes
Transaction Date	Used to specify the date when the transaction was performed.	Yes
Manual Entry	Indicates that the transaction is manually entered in the system.	Not applicable

Field Name	Field Description	Mandatory (Yes or No)
Credit/Debit Indicator	Used to indicate whether the transaction is a debit or credit transaction.	Yes
External Reference Number	Used to specify the external reference number of the transaction.	No
Price Item Reference Number	Used to indicate the person who performed the transaction.	No
Account Identifier Type	Used to specify the type of account identifier.	Yes (Conditional) <b>Note:</b> If you enter the account identifier as a search criteria, you have to select the account identifier type.
Account Identifier	Used to indicate the account for which the transaction was performed.	Yes (Conditional) <b>Note:</b> If you specify the account identifier type as a search criteria, you have to enter the account identifier.
Transaction Amount	Used to specify the transaction amount.	Yes
Transaction Currency	Used to indicate the currency in which the transaction was performed.	Yes
Transaction Volume	Used to specify the transaction volume.	Yes
Additional Amount 1, Additional Amount 2, ..., Additional Amount 10  <b>Note:</b> If the business label is defined for any of these user defined fields, the business label appears instead of the field name.	Used to specify additional information about the transaction.	Yes (Conditional) <b>Note:</b> This field is required when you are specifying the currency in the corresponding field.
Amount 1 Currency Code, Amount 2 Currency Code, ..., Amount 10 Currency Code  <b>Note:</b> If the business label is defined for any of these user defined fields, the business label appears instead of the field name.	Used to specify additional information about the transaction.	Yes (Conditional) <b>Note:</b> This field is required when you are specifying the amount in the corresponding field.



Field Name	Field Description	Mandatory (Yes or No)
Additional Date 1, Additional Date 2, ..., Additional Date 5  <b>Note:</b> If the business label is defined for any of these user defined fields, the business label appears instead of the field name.	Used to specify additional information about the transaction.	No
Additional Numeric Data 1, Additional Numeric Data 2, Additional Numeric Data 3, ....., Additional Numeric Data 20  <b>Note:</b> If the business label is defined for any of these user defined fields, the business label appears instead of the field name.	Used to specify additional information about the transaction.	No
Additional Data 1, Additional Data 2, Additional Data 3, ..., Additional Data 50  <b>Note:</b> If the business label is defined for any of these user defined fields, the business label appears instead of the field name.	Used to specify additional information about the transaction.	No

4. Enter the required details.
5. Click **Save**.

The new transaction is added in the system.

#### **Related Topics**

For more information on...	See...
How to view the details of a transaction	<a href="#">Viewing the Transaction Details</a> on page 986

## **Transaction Source**

---

The **Transaction Source** screen allows you to define, edit, delete, and copy a transaction source. This screen consists of the following zones:

- [Search Transaction Source](#) on page 994



## Search Transaction Source

The **Search Transaction Source** zone allows you to search for a transaction source. This zone contains the following two sections:

- **Search Criteria** — The **Search Criteria** section contains the following fields:

Field Name	Field Description	Mandatory (Yes or No)
Transaction Source	Used to search a particular transaction source.	No
Description	Used to search transaction sources with a particular description.	No

- **Search Results** — On clicking the **Search** button, the search results appear based on the specified search criteria. The **Search Results** section contains the following columns:

Column Name	Column Description
Transaction Source	Displays the transaction source.
Description	Displays the description of the transaction source.
Account Identifier Type	Indicates the type of account identifier that will be received from the transaction source.
Edit	On clicking the <b>Edit</b>  icon, the <b>Transaction Source</b> screen appears where you can edit the details of the transaction source.
Delete	On clicking the <b>Delete</b>  icon, you can delete the transaction source. <b>Note:</b> You can only delete a transaction source which is not yet used.
Copy	On clicking the <b>Copy</b>  icon, the <b>Transaction Source</b> screen appears where you can create a transaction source using an existing transaction source.

You can create a new transaction source by clicking the **Add** link in the upper right corner of this zone.

### Related Topics

For more information on...	See...
How to search for a transaction source	<a href="#">Searching for a Transaction Source</a> on page 994
How to define a transaction source	<a href="#">Defining a Transaction Source</a> on page 995
How to edit a transaction source	<a href="#">Editing a Transaction Source</a> on page 996
How to delete a transaction source	<a href="#">Deleting a Transaction Source</a> on page 996
How to copy a transaction source	<a href="#">Copying a Transaction Source</a> on page 997

## Searching for a Transaction Source

### Procedure

To search for a transaction source:

1. Click the **Admin** link in the **Application** toolbar.

A list appears.

- From the **Admin** menu, select **T** and then click **Transaction Source**.

The **Transaction Source** screen appears.

- Enter the search criteria in the **Search Transaction Source** zone.

**Note:** ORMB search engine supports wildcard search, where you can substitute the percentage (%) symbol as a stand in for any word or letter in a search criteria. You can use the ‘%’ wildcard character in all input fields except the date and ID fields. The ‘%’ wildcard character is suffixed automatically at the end of the partial search criteria. Therefore, you may or may not specify the wildcard character at the end of the partial search criteria. However, you have to prefix the wildcard character manually wherever required.

- Click **Search**.

A list of transaction sources that meet the search criteria appears in the **Search Results** section.

### **Related Topics**

<b>For more information on...</b>	<b>See...</b>
<b>Transaction Source</b> screen	<a href="#">Transaction Source</a> on page 993
<b>Search Transaction Source</b> zone	<a href="#">Search Transaction Source</a> on page 994

## **Defining a Transaction Source**

### **Prerequisites**

To define a transaction source, you should have:

- Account identifier types defined in the application

### **Procedure**

To define a transaction source:

- Click the **Admin** link in the **Application** toolbar.

A list appears.

- From the **Admin** menu, select **T** and then click **Transaction Source**.

The **Transaction Source** screen appears.

- Click the **Add** link in the upper right corner of the **Search Transaction Source** zone.

The **Transaction Source** screen appears. It contains the following fields:

<b>Field Name</b>	<b>Field Description</b>	<b>Mandatory (Yes or No)</b>
Transaction Source	Used to specify the transaction source.  <b>Note:</b> You cannot specify any special character except underscore (_) in the transaction source.	Yes
Description	Used to specify the description for the transaction source.	Yes
Account Identifier Type	Used to indicate the type of account identifier that will be received from the transaction source.	Yes

- Enter the required details.
- Click **Save**.

The transaction source is defined.

### Related Topics

For more information on...	See...
Transaction Source screen	<a href="#">Transaction Source</a> on page 993
Search Transaction Source zone	<a href="#">Search Transaction Source</a> on page 994

## Editing a Transaction Source

### Prerequisites

To edit a transaction source, you should have:

- Account identifier types defined in the application

### Procedure

To edit a transaction source:

1. Search for the transaction source in the **Transaction Source** screen.
2. In the **Search Results** section, click the **Edit** (✎) icon in the **Edit** column corresponding to the transaction source whose details you want to edit.

The **Transaction Source** screen appears. It contains the following fields:

Field Name	Field Description	Mandatory (Yes or No)
Transaction Source	Displays the transaction source.	Not applicable
Description	Used to specify the description for the transaction source.	Yes
Account Identifier Type	Used to indicate the type of account identifier that will be received from the transaction source.	Yes

3. Modify the required details.
4. Click **Save**.

The changes made to the transaction source are saved.

### Related Topics

For more information on...	See...
How to search for a transaction source	<a href="#">Searching for a Transaction Source</a> on page 994

## Deleting a Transaction Source

### Procedure

To delete a transaction source:

1. Search for the transaction source in the **Transaction Source** screen.

- In the **Search Results** section, click the **Delete** () icon in the **Delete** column corresponding to the transaction source that you want to delete.

A message appears confirming whether you want to delete the transaction source.

**Note:** You can only delete a transaction source which is not yet used.

- Click **OK**.

The transaction source is deleted.

### **Related Topics**

For more information on...	See...
How to search for a transaction source	<a href="#">Searching for a Transaction Source</a> on page 994

## **Copying a Transaction Source**

Instead of creating a transaction source from scratch, you can create a new transaction source using an existing transaction source. This is possible through copying a transaction source. Once you create a copy of a transaction source, the record types defined for the original transaction source are also copied to the new transaction source.

### **Prerequisites**

To copy a transaction source, you should have:

- Transaction source (whose copy you want to create) defined in the application
- Account identifier types defined in the application

### **Procedure**

To copy a transaction source:

- Search for the transaction source in the **Transaction Source** screen.
- In the **Search Results** section, click the **Copy** () icon in the **Copy** column corresponding to the transaction source whose copy you want to create.

The **Transaction Source** screen appears. It contains the following fields:

Field Name	Field Description	Mandatory (Yes or No)
Transaction Source	Used to specify the transaction source. <b>Note:</b> You cannot specify any special character except underscore (_) in the transaction source.	Yes
Description	Used to specify the description for the transaction source.	Yes
Account Identifier Type	Used to indicate the type of account identifier that will be received from the transaction source.	Yes

- Enter the required details.
- Click **Save**.

The new transaction source is defined.

### **Related Topics**

<b>For more information on...</b>	<b>See...</b>
How to search for a transaction source	<a href="#">Searching for a Transaction Source</a> on page 994

## Transaction Record Type

The **Transaction Record Type** screen allows you to define, edit, delete, and copy a transaction record type. While defining a transaction record type, you need to define a rule type. This rule type is invoked for transactions with the transaction source and record type combination. While defining a rule type, you can select the transaction detail fields that you want to use as input or output parameters in a rule.

Besides using the transaction detail fields, the system allows you to use fields which are not part of the standard transaction details. These fields are referred to as temporary fields and are defined similar to other fields, but are not associated with any ORMB tables. You need to associate temporary fields with the rule type while defining a transaction record type. Once associated, you can use the temporary field as input or output parameter while defining a rule using the rule type.

**Note:** At present, you can only associate a temporary field with a rule type, but cannot use the temporary field in a rule which is created using the rule type. The latter part of the functionality will be available in a future release of Oracle Revenue Management and Billing.

The **Transaction Record Type** screen consists of the following zones:

- [Search Transaction Record Type](#) on page 998

## Search Transaction Record Type



The **Search Transaction Record Type** zone allows you to search for a transaction record type. This zone contains the following two sections:

- **Search Criteria** — The **Search Criteria** section contains the following fields:

Field Name	Field Description	Mandatory (Yes or No)
Transaction Source	Used to search transaction record types defined for a particular transaction source.	No
Transaction Record Type	Used to search a particular transaction record type.	No
Description	Used to search transaction record types with a particular description.	No

- **Search Results** — On clicking the **Search** button, the search results appear based on the specified search criteria. The **Search Results** section contains the following columns:

Column Name	Column Description
Transaction Record Type	Displays the transaction record type.
Description	Displays the description of the transaction record type.
Transaction Source	Indicates the transaction source for which the transaction record type is defined.

Column Name	Column Description
Rule Type	Indicates the rule type that is invoked for the transaction record type.  <b>Note:</b> It has a link. On clicking the link, the <b>View Rule Type</b> screen appears where you can view the details of the respective rule type.
Edit	On clicking the <b>Edit</b> (  ) icon, the <b>Transaction Record Type</b> screen appears where you can edit the details of the transaction record type.
Delete	On clicking the <b>Delete</b> (  ) icon, you can delete the transaction record type.  <b>Note:</b> You can delete a transaction record type when: <ul style="list-style-type: none"> <li>• It is not yet used.</li> <li>• Rules are not yet defined using the rule type which is invoked by the transaction source and record type combination.</li> </ul>
Copy	On clicking the <b>Copy</b> (  ) icon, the <b>Transaction Record Type</b> screen appears where you can create a new transaction record type using an existing transaction record type.

You can create a new transaction record type by clicking the **Add** link in the upper right corner of this zone.

### Related Topics

For more information on...	See...
How to search for a transaction record type	<a href="#">Searching for a Transaction Record Type</a> on page 999
How to define a transaction record type	<a href="#">Defining a Transaction Record Type</a> on page 1000
How to edit a transaction record type	<a href="#">Editing a Transaction Record Type</a> on page 1005
How to delete a transaction record type	<a href="#">Deleting a Transaction Record Type</a> on page 1011
How to copy a transaction record type	<a href="#">Copying a Transaction Record Type</a> on page 1012

## Searching for a Transaction Record Type

### Procedure

To search for a transaction record type:

1. Click the **Admin** link in the **Application** toolbar.  
A list appears.
2. From the **Admin** menu, select **T** and then click **Transaction Record Type**.  
The **Transaction Record Type** screen appears.
3. Enter the search criteria in the **Search Transaction Record Type** zone.

**Note:** ORMB search engine supports wildcard search, where you can substitute the percentage (%) symbol as a stand in for any word or letter in a search criteria. You can use the ‘%’ wildcard character in all input fields except the date and ID fields. The ‘%’ wildcard character is suffixed automatically at the end of the partial search criteria. Therefore, you may or may not specify the wildcard character at the end of the partial search criteria. However, you have to prefix the wildcard character manually wherever required.

4. Click **Search**.

The search results appear.

### Related Topics

For more information on...	See...
<b>Transaction Record Type</b> screen	<a href="#">Transaction Record Type</a> on page 998
<b>Search Transaction Record Type</b> zone	<a href="#">Search Transaction Record Type</a> on page 998

## Defining a Transaction Record Type

### Prerequisites

To define a transaction record type, you should have:

- Transaction sources defined in the application
- Validation algorithm defined using the C1-RULE-VAL algorithm type
- Transaction Information String algorithm defined using the C1-TXDETINFO algorithm type
- Fields (that you want to use as input or output parameter) defined in the application

### Procedure

To define a transaction record type:

1. Click the **Admin** link in the **Application** toolbar.

A list appears.

2. From the **Admin** menu, select **T** and then click **Transaction Record Type**.



The **Transaction Record Type** screen appears.

3. Click the **Add** link in the upper right corner of the **Search Transaction Record Type** zone.

The **Transaction Record Type** screen appears. It contains the following fields:

Field Name	Field Description	Mandatory (Yes or No)
Transaction Source	Used to indicate the transaction source for which you want to define the transaction record type.  <b>Note:</b> The <b>Search</b>  icon appears corresponding to this field. On clicking the <b>Search</b> icon, the <b>Search Transaction Source</b> window appears.	Yes
Transaction Record Type	Used to specify the transaction record type.  <b>Note:</b> You cannot specify any special character except underscore (_) in the transaction record type.	Yes
Description	Used to specify the description for the transaction record type.	Yes



Field Name	Field Description	Mandatory (Yes or No)
Rule Type	Used to specify the rule type.  <b>Note:</b> You cannot specify any special character except underscore (_) in the rule type.	Yes
Rule Type Description	Used to specify the description for the rule type.	Yes
Rule Validation Algorithm	Used to specify the validation algorithm that will be triggered when a rule is defined using the rule type.  <b>Note:</b> This algorithm checks whether: <ul style="list-style-type: none"> <li>• The values specified against the output parameters exist in the system</li> <li>• The same price item parameter (for example, PCD1_1_1_VAL) is not used multiple times for a division, account, and price item combination</li> </ul> The <b>Search</b>  icon appears corresponding to this field. On clicking the <b>Search</b> icon, the <b>Algorithm Search</b> window appears.	No
Info String Algorithm	Used to specify the algorithm that will generate the information string which appears in the <b>Transaction Information</b> column throughout the application.  <b>Note:</b> This algorithm concatenates the fields (related to the transaction) and delimiters specified as parameters in the algorithm.  The <b>Search</b>  icon appears corresponding to this field. On clicking the <b>Search</b> icon, the <b>Algorithm Search</b> window appears.	No

Field Name	Field Description	Mandatory (Yes or No)
Maximum Accounts to be charged	<p>Used to indicate the maximum number of accounts which can bear the charges for a transaction. The valid values are:</p> <ul style="list-style-type: none"> <li>• 01</li> <li>• 02</li> <li>• 03</li> <li>• 04</li> <li>• 05</li> <li>• 06</li> <li>• 07</li> <li>• 08</li> <li>• 09</li> <li>• 10</li> </ul> <p><b>Note:</b> At present, the system supports maximum 10 accounts which can bear the charges for a transaction.</p>	Yes
Maximum Price Items to be mapped	<p>Used to indicate the maximum number of price items to which a transaction can be mapped for each account. The valid values are:</p> <ul style="list-style-type: none"> <li>• 01</li> <li>• 02</li> <li>• 03</li> <li>• 04</li> <li>• 05</li> <li>• 06</li> <li>• 07</li> <li>• 08</li> <li>• 09</li> <li>• 10</li> </ul> <p><b>Note:</b> At present, the system supports maximum 10 price items to which a transaction can be mapped for each account.</p>	Yes

Field Name	Field Description	Mandatory (Yes or No)
Maximum Price Item Parameters	<p>Used to indicate the maximum number of parameters that can be used with each price item to determine the price item pricing. The valid values are:</p> <ul style="list-style-type: none"> <li>• 00</li> <li>• 01</li> <li>• 02</li> <li>• 03</li> <li>• 04</li> <li>• 05</li> <li>• 06</li> <li>• 07</li> <li>• 08</li> <li>• 09</li> <li>• 10</li> <li>• 11</li> <li>• 12</li> <li>• 13</li> <li>• 14</li> <li>• 15</li> </ul> <p><b>Note:</b> At present, the system supports maximum 15 parameters that can be used with each price item to determine the price item pricing.</p>	Yes

In addition, this screen contains the following two sections:

- **Input/Output Parameters** — Enables you to select the transaction detail fields that you can use as input or output parameter while defining a rule. It contains the following fields:

Field Name	Field Description	Mandatory (Yes or No)
Rule Input/Output	Used to indicate whether you want to use the transaction detail field as input or output parameter.	No
Transaction Field	Displays the transaction field name.	Not applicable
Business Label	<p>Used to specify a business label for the user defined fields.</p> <p><b>Note:</b> The business label appears when you add, copy, or view a transaction in the <b>Transaction Details</b> screen. The label changes depending on the transaction source and record type combination that you have selected.</p>	No

**Note:** At present, you can use the following transaction fields as input or output parameter while defining a rule — Account Identifier (ACCT\_NBR), Account Identifier Type (ACCT\_NBR\_TYPE\_CD), Division (CIS\_DIVISION), Currency Code (CURRENCY\_CD), Customer Reference Number (CUST\_REF\_NBR), Do not Aggregate Switch (DO\_NOT\_AGG\_SW), External Reference Number (EXT\_TXN\_NBR), Credit/Debit Indicator (HOW\_TO\_USE\_TXN\_FLG), Manual Entry (MANUAL\_SW), Transaction Amount (TXN\_AMT), Transaction Date (TXN\_DTTM), Transaction Record Type (TXN\_REC\_TYPE\_CD), Transaction Source (TXN\_SOURCE\_CD), Transaction Upload Date (TXN\_UPLOAD\_DTTM), Transaction Volume (TXN\_VOL), Additional Amount 1 (UDF\_AMT\_1), Additional Amount 2 (UDF\_AMT\_2), Additional Amount 3 (UDF\_AMT\_3), Additional Amount 4 (UDF\_AMT\_4), Additional Amount 5 (UDF\_AMT\_5), Additional Amount 6 (UDF\_AMT\_6), Additional Amount 7 (UDF\_AMT\_7), Additional Amount 8 (UDF\_AMT\_8), Additional Amount 9 (UDF\_AMT\_9), Additional Amount 10 (UDF\_AMT\_10), Additional Data 1 (UDF\_CHAR\_1), Additional Data 2 (UDF\_CHAR\_2), Additional Data 3 (UDF\_CHAR\_3), Additional Data 4 (UDF\_CHAR\_4), Additional Data 5 (UDF\_CHAR\_5), Additional Data 6 (UDF\_CHAR\_6), Additional Data 7 (UDF\_CHAR\_7), Additional Data 8 (UDF\_CHAR\_8), Additional Data 9 (UDF\_CHAR\_9), Additional Data 10 (UDF\_CHAR\_10), Additional Data 11 (UDF\_CHAR\_11), Additional Data 12 (UDF\_CHAR\_12), Additional Data 13 (UDF\_CHAR\_13), Additional Data 14 (UDF\_CHAR\_14), Additional Data 15 (UDF\_CHAR\_15), Additional Data 16 (UDF\_CHAR\_16), Additional Data 17 (UDF\_CHAR\_17), Additional Data 18 (UDF\_CHAR\_18), Additional Data 19 (UDF\_CHAR\_19), Additional Data 20 (UDF\_CHAR\_20), Additional Data 21 (UDF\_CHAR\_21), Additional Data 22 (UDF\_CHAR\_22), Additional Data 23 (UDF\_CHAR\_23), Additional Data 24 (UDF\_CHAR\_24), Additional Data 25 (UDF\_CHAR\_25), Additional Data 26 (UDF\_CHAR\_26), Additional Data 27 (UDF\_CHAR\_27), Additional Data 28 (UDF\_CHAR\_28), Additional Data 29 (UDF\_CHAR\_29), Additional Data 30 (UDF\_CHAR\_30), Additional Data 31 (UDF\_CHAR\_31), Additional Data 32 (UDF\_CHAR\_32), Additional Data 33 (UDF\_CHAR\_33), Additional Data 34 (UDF\_CHAR\_34), Additional Data 35 (UDF\_CHAR\_35), Additional Data 36 (UDF\_CHAR\_36), Additional Data 37 (UDF\_CHAR\_37), Additional Data 38 (UDF\_CHAR\_38), Additional Data 39 (UDF\_CHAR\_39), Additional Data 40 (UDF\_CHAR\_40), Additional Data 41 (UDF\_CHAR\_41), Additional Data 42 (UDF\_CHAR\_42), Additional Data 43 (UDF\_CHAR\_43), Additional Data 44 (UDF\_CHAR\_44), Additional Data 45 (UDF\_CHAR\_45), Additional Data 46 (UDF\_CHAR\_46), Additional Data 47 (UDF\_CHAR\_47), Additional Data 48 (UDF\_CHAR\_48), Additional Data 49 (UDF\_CHAR\_49), Additional Data 50 (UDF\_CHAR\_50), Amount 1 Currency Code (UDF\_CURRENCY\_CD\_1), Amount 2 Currency Code (UDF\_CURRENCY\_CD\_2), Amount 3 Currency Code (UDF\_CURRENCY\_CD\_3), Amount 4 Currency Code (UDF\_CURRENCY\_CD\_4), Amount 5 Currency Code (UDF\_CURRENCY\_CD\_5), Amount 6 Currency Code (UDF\_CURRENCY\_CD\_6), Amount 7 Currency Code (UDF\_CURRENCY\_CD\_7), Amount 8 Currency Code (UDF\_CURRENCY\_CD\_8), Amount 9 Currency Code (UDF\_CURRENCY\_CD\_9), Amount 10 Currency Code (UDF\_CURRENCY\_CD\_10), Additional Date 1 (UDF\_DTTM\_1), Additional Date 2 (UDF\_DTTM\_2), Additional Date 3 (UDF\_DTTM\_3), Additional Date 4 (UDF\_DTTM\_4), Additional Date 5 (UDF\_DTTM\_5), Additional Numeric Data 1 (UDF\_NBR\_1), Additional Numeric Data 2 (UDF\_NBR\_2), Additional Numeric Data 3 (UDF\_NBR\_3), Additional Numeric Data 4 (UDF\_NBR\_4), Additional Numeric Data 5 (UDF\_NBR\_5), Additional Numeric Data 6 (UDF\_NBR\_6), Additional Numeric Data 7 (UDF\_NBR\_7), Additional Numeric Data 8 (UDF\_NBR\_8), Additional Numeric Data 9 (UDF\_NBR\_9), Additional Numeric Data 10 (UDF\_NBR\_10), Additional Numeric Data 11 (UDF\_NBR\_11), Additional Numeric Data 12 (UDF\_NBR\_12), Additional Numeric Data 13 (UDF\_NBR\_13), Additional Numeric Data 14 (UDF\_NBR\_14), Additional Numeric Data 15 (UDF\_NBR\_15), Additional Numeric Data 16 (UDF\_NBR\_16), Additional Numeric Data 17 (UDF\_NBR\_17), Additional Numeric Data 18 (UDF\_NBR\_18), Additional Numeric Data 19 (UDF\_NBR\_19), Additional Numeric Data 20 (UDF\_NBR\_20).

- **Temporary Fields** — Enables you to select non-transactional fields that you can use as input or output parameter while defining a rule. It contains the following fields:



Field Name	Field Description	Mandatory (Yes or No)
Temporary Field	Used to indicate the non-transactional field that you want to use as input or output parameter.  <b>Note:</b> The <b>Search</b>  icon appears corresponding to this field. On clicking the <b>Search</b> icon, the <b>Transaction Record Type Tempo Field Search</b> window appears.	No

4. Enter the required details.

**Note:** You can search for a transaction source and algorithm by clicking the **Search**  icon corresponding to the respective field.

5. Select the check box corresponding to the transaction fields that you want to use as input or output parameters.
6. If required, you can select a non-transactional field as input or output parameter in the **Temporary Fields** section.

**Note:**  
You can search for a field by clicking the **Search**  icon corresponding to the respective field.

If you want to add more than one temporary field to the transaction record type, click the **Add**  icon and then repeat step 7. However, if you want to remove a temporary field from the transaction record type, click the **Delete**  icon corresponding to the temporary field.

7. Click **Save**.

The transaction record type is defined.

### **Related Topics**

For more information on...	See...
<b>Transaction Record Type</b> screen	<a href="#">Transaction Record Type</a> on page 998
<b>Search Transaction Record Type</b> zone	<a href="#">Search Transaction Record Type</a> on page 998

## **Editing a Transaction Record Type**

### **Prerequisites**

To edit a transaction record type, you should have:



- Validation algorithm defined using the C1-RULE-VAL algorithm type
- Transaction Information String algorithm defined using the C1-TXDETINFO algorithm type
- Fields (that you want to use as input or output parameter) defined in the application

### **Procedure**

To edit a transaction record type:

1. Search for the transaction record type in the **Transaction Record Type** screen.
2. In the **Search Results** section, click the **Edit**  icon in the **Edit** column corresponding to the transaction record type whose details you want to edit.

The **Transaction Record Type** screen appears. It contains the following fields:

Field Name	Field Description	Mandatory (Yes or No)
Transaction Source	Used to indicate the transaction source for which you want to define the transaction record type.  <b>Note:</b> The <b>Search</b>  icon appears corresponding to this field. On clicking the <b>Search</b> icon, the <b>Search Transaction Source</b> window appears.	Yes
Transaction Record Type	Used to specify the transaction record type.  <b>Note:</b> You cannot specify any special character except underscore (_) in the transaction record type.	Yes
Description	Used to specify the description for the transaction record type.	Yes
Rule Type	Used to specify the rule type.  <b>Note:</b> You cannot specify any special character except underscore (_) in the rule type.	Yes
Rule Type Description	Used to specify the description for the rule type.	Yes
Rule Validation Algorithm	Used to specify the validation algorithm that will be triggered when a rule is defined using the rule type.  <b>Note:</b> This algorithm checks whether: <ul style="list-style-type: none"> <li>• The values specified against the output parameters exist in the system</li> <li>• The same price item parameter (for example, PCD1_1_1_VAL) is not used multiple times for a division, account, and price item combination</li> </ul> The <b>Search</b>  icon appears corresponding to this field. On clicking the <b>Search</b> icon, the <b>Algorithm Search</b> window appears.	No

Field Name	Field Description	Mandatory (Yes or No)
Info String Algorithm	<p>Used to specify the algorithm that will generate the information string which appears in the <b>Transaction Information</b> column throughout the application.</p> <p><b>Note:</b> This algorithm concatenates the fields (related to the transaction) and delimiters specified as parameters in the algorithm.</p> <p>The <b>Search</b>  icon appears corresponding to this field. On clicking the <b>Search</b> icon, the <b>Algorithm Search</b> window appears.</p>	No
Maximum Accounts to be charged	<p>Used to indicate the maximum number of accounts which can bear the charges for a transaction. The valid values are:</p> <ul style="list-style-type: none"> <li>• 01</li> <li>• 02</li> <li>• 03</li> <li>• 04</li> <li>• 05</li> <li>• 06</li> <li>• 07</li> <li>• 08</li> <li>• 09</li> <li>• 10</li> </ul> <p><b>Note:</b> At present, the system supports maximum 10 accounts which can bear the charges for a transaction.</p>	Yes

Field Name	Field Description	Mandatory (Yes or No)
Maximum Price Items to be mapped	<p>Used to indicate the maximum number of price items to which a transaction can be mapped for each account. The valid values are:</p> <ul style="list-style-type: none"><li>• 01</li><li>• 02</li><li>• 03</li><li>• 04</li><li>• 05</li><li>• 06</li><li>• 07</li><li>• 08</li><li>• 09</li><li>• 10</li></ul> <p><b>Note:</b> At present, the system supports maximum 10 price items to which a transaction can be mapped for each account.</p>	Yes



Field Name	Field Description	Mandatory (Yes or No)
Maximum Price Item Parameters	<p>Used to indicate the maximum number of parameters that can be used with each price item to determine the price item pricing. The valid values are:</p> <ul style="list-style-type: none"> <li>• 00</li> <li>• 01</li> <li>• 02</li> <li>• 03</li> <li>• 04</li> <li>• 05</li> <li>• 06</li> <li>• 07</li> <li>• 08</li> <li>• 09</li> <li>• 10</li> <li>• 11</li> <li>• 12</li> <li>• 13</li> <li>• 14</li> <li>• 15</li> </ul> <p><b>Note:</b> At present, the system supports maximum 15 parameters that can be used with each price item to determine the price item pricing.</p>	Yes

In addition, this screen contains the following two sections:

- **Input/Output Parameters** — Enables you to select the transaction detail fields that you can use as input or output parameter while defining a rule. It contains the following fields:

Field Name	Field Description	Mandatory (Yes or No)
Rule Input/Output	Used to indicate whether you want to use the transaction detail field as input or output parameter.	No
Transaction Field	Displays the transaction field name.	Not applicable
Business Label	<p>Used to specify a business label for the user defined fields.</p> <p><b>Note:</b> The business label appears when you add, copy, or view a transaction in the <b>Transaction Details</b> screen. The label changes depending on the transaction source and record type combination that you have selected.</p>	No

**Note:** At present, you can use the following transaction fields as input or output parameter while defining a rule — Account Identifier (ACCT\_NBR), Account Identifier Type (ACCT\_NBR\_TYPE\_CD), Division (CIS\_DIVISION), Currency Code (CURRENCY\_CD), Customer Reference Number (CUST\_REF\_NBR), Do not Aggregate Switch (DO\_NOT\_AGG\_SW), External Reference Number (EXT\_TXN\_NBR), Credit/Debit Indicator (HOW\_TO\_USE\_TXN\_FLG), Manual Entry (MANUAL\_SW), Transaction Amount (TXN\_AMT), Transaction Date (TXN\_DTTM), Transaction Record Type (TXN\_REC\_TYPE\_CD), Transaction Source (TXN\_SOURCE\_CD), Transaction Upload Date (TXN\_UPLOAD\_DTTM), Transaction Volume (TXN\_VOL), Additional Amount 1 (UDF\_AMT\_1), Additional Amount 2 (UDF\_AMT\_2), Additional Amount 3 (UDF\_AMT\_3), Additional Amount 4 (UDF\_AMT\_4), Additional Amount 5 (UDF\_AMT\_5), Additional Amount 6 (UDF\_AMT\_6), Additional Amount 7 (UDF\_AMT\_7), Additional Amount 8 (UDF\_AMT\_8), Additional Amount 9 (UDF\_AMT\_9), Additional Amount 10 (UDF\_AMT\_10), Additional Data 1 (UDF\_CHAR\_1), Additional Data 2 (UDF\_CHAR\_2), Additional Data 3 (UDF\_CHAR\_3), Additional Data 4 (UDF\_CHAR\_4), Additional Data 5 (UDF\_CHAR\_5), Additional Data 6 (UDF\_CHAR\_6), Additional Data 7 (UDF\_CHAR\_7), Additional Data 8 (UDF\_CHAR\_8), Additional Data 9 (UDF\_CHAR\_9), Additional Data 10 (UDF\_CHAR\_10), Additional Data 11 (UDF\_CHAR\_11), Additional Data 12 (UDF\_CHAR\_12), Additional Data 13 (UDF\_CHAR\_13), Additional Data 14 (UDF\_CHAR\_14), Additional Data 15 (UDF\_CHAR\_15), Additional Data 16 (UDF\_CHAR\_16), Additional Data 17 (UDF\_CHAR\_17), Additional Data 18 (UDF\_CHAR\_18), Additional Data 19 (UDF\_CHAR\_19), Additional Data 20 (UDF\_CHAR\_20), Additional Data 21 (UDF\_CHAR\_21), Additional Data 22 (UDF\_CHAR\_22), Additional Data 23 (UDF\_CHAR\_23), Additional Data 24 (UDF\_CHAR\_24), Additional Data 25 (UDF\_CHAR\_25), Additional Data 26 (UDF\_CHAR\_26), Additional Data 27 (UDF\_CHAR\_27), Additional Data 28 (UDF\_CHAR\_28), Additional Data 29 (UDF\_CHAR\_29), Additional Data 30 (UDF\_CHAR\_30), Additional Data 31 (UDF\_CHAR\_31), Additional Data 32 (UDF\_CHAR\_32), Additional Data 33 (UDF\_CHAR\_33), Additional Data 34 (UDF\_CHAR\_34), Additional Data 35 (UDF\_CHAR\_35), Additional Data 36 (UDF\_CHAR\_36), Additional Data 37 (UDF\_CHAR\_37), Additional Data 38 (UDF\_CHAR\_38), Additional Data 39 (UDF\_CHAR\_39), Additional Data 40 (UDF\_CHAR\_40), Additional Data 41 (UDF\_CHAR\_41), Additional Data 42 (UDF\_CHAR\_42), Additional Data 43 (UDF\_CHAR\_43), Additional Data 44 (UDF\_CHAR\_44), Additional Data 45 (UDF\_CHAR\_45), Additional Data 46 (UDF\_CHAR\_46), Additional Data 47 (UDF\_CHAR\_47), Additional Data 48 (UDF\_CHAR\_48), Additional Data 49 (UDF\_CHAR\_49), Additional Data 50 (UDF\_CHAR\_50), Amount 1 Currency Code (UDF\_CURRENCY\_CD\_1), Amount 2 Currency Code (UDF\_CURRENCY\_CD\_2), Amount 3 Currency Code (UDF\_CURRENCY\_CD\_3), Amount 4 Currency Code (UDF\_CURRENCY\_CD\_4), Amount 5 Currency Code (UDF\_CURRENCY\_CD\_5), Amount 6 Currency Code (UDF\_CURRENCY\_CD\_6), Amount 7 Currency Code (UDF\_CURRENCY\_CD\_7), Amount 8 Currency Code (UDF\_CURRENCY\_CD\_8), Amount 9 Currency Code (UDF\_CURRENCY\_CD\_9), Amount 10 Currency Code (UDF\_CURRENCY\_CD\_10), Additional Date 1 (UDF\_DTTM\_1), Additional Date 2 (UDF\_DTTM\_2), Additional Date 3 (UDF\_DTTM\_3), Additional Date 4 (UDF\_DTTM\_4), Additional Date 5 (UDF\_DTTM\_5), Additional Numeric Data 1 (UDF\_NBR\_1), Additional Numeric Data 2 (UDF\_NBR\_2), Additional Numeric Data 3 (UDF\_NBR\_3), Additional Numeric Data 4 (UDF\_NBR\_4), Additional Numeric Data 5 (UDF\_NBR\_5), Additional Numeric Data 6 (UDF\_NBR\_6), Additional Numeric Data 7 (UDF\_NBR\_7), Additional Numeric Data 8 (UDF\_NBR\_8), Additional Numeric Data 9 (UDF\_NBR\_9), Additional Numeric Data 10 (UDF\_NBR\_10), Additional Numeric Data 11 (UDF\_NBR\_11), Additional Numeric Data 12 (UDF\_NBR\_12), Additional Numeric Data 13 (UDF\_NBR\_13), Additional Numeric Data 14 (UDF\_NBR\_14), Additional Numeric Data 15 (UDF\_NBR\_15), Additional Numeric Data 16 (UDF\_NBR\_16), Additional Numeric Data 17 (UDF\_NBR\_17), Additional Numeric Data 18 (UDF\_NBR\_18), Additional Numeric Data 19 (UDF\_NBR\_19), Additional Numeric Data 20 (UDF\_NBR\_20).

- **Temporary Fields** — Enables you to select non-transactional fields that you can use as input or output parameter while defining a rule. It contains the following fields:



Field Name	Field Description	Mandatory (Yes or No)
Temporary Field	Used to indicate the non-transactional field that you want to use as input or output parameter.  <b>Note:</b> The <b>Search</b> (  ) icon appears corresponding to this field. On clicking the <b>Search</b> icon, the <b>Transaction Record Type Tempo Field Search</b> window appears.	No

### 3. Modify the required details.

**Note:**

You can search for an algorithm and field by clicking the **Search** () icon corresponding to the respective field.

You can edit and remove an input or output parameter from a rule type only when it is not yet used in a rule (which is created using the rule type).

If you want to add more than one temporary field to the transaction record type, click the **Add** () icon and then specify the details in the **Temporary Fields** section. However, if you want to remove a temporary field from the transaction record type, click the **Delete** () icon corresponding to the temporary field.

### 4. Click **Save**.

The changes made to the transaction record type are saved.

### **Related Topics**

For more information on...	See...
How to search for a transaction record type	<a href="#">Searching for a Transaction Record Type</a> on page 999

## Deleting a Transaction Record Type

### **Procedure**

To delete a transaction record type:

1. Search for the transaction record type in the **Transaction Record Type** screen.
2. In the **Search Results** section, click the **Delete** () icon in the **Delete** column corresponding to the transaction record type that you want to delete.

A message appears confirming whether you want to delete the transaction record type.

**Note:** You can only delete a transaction record type which is not yet used.

### 3. Click **OK**.

The transaction record type is deleted.

### **Related Topics**

<b>For more information on...</b>	<b>See...</b>
How to search for a transaction record type	<a href="#">Searching for a Transaction Record Type</a> on page 999

## Copying a Transaction Record Type

Instead of creating a transaction record type from scratch, you can create a new transaction record type using an existing transaction record type. This is possible through copying a transaction record type. Once you create a copy of a transaction record type, the input or output parameters and temporary fields are also copied to the new transaction record type. You can then edit the details, if required.

### Prerequisites

To copy a transaction record type, you should have:

- Transaction record type (whose copy you want to create) defined in the application
- Validation algorithm defined using the C1-RULE-VAL algorithm type
- Transaction Information String algorithm defined using the C1-TXDETINFO algorithm type
- Fields (that you want to use as input or output parameter) defined in the application



### Procedure

To copy a transaction record type:

1. Search for the transaction record type in the **Transaction Record Type** screen.
2. In the **Search Results** section, click the **Copy** ( icon in the **Copy** column corresponding to the transaction record type whose copy you want to create.

The **Transaction Record Type** screen appears. It contains the following fields:

Field Name	Field Description	Mandatory (Yes or No)
Transaction Source	Used to indicate the transaction source for which you want to define the transaction record type.  <b>Note:</b> The <b>Search</b> (  ) icon appears corresponding to this field. On clicking the <b>Search</b> icon, the <b>Search Transaction Source</b> window appears.	Yes
Transaction Record Type	Used to specify the transaction record type.  <b>Note:</b> You cannot specify any special character except underscore (_) in the transaction record type.	Yes
Description	Used to specify the description for the transaction record type.	Yes
Rule Type	Used to specify the rule type.  <b>Note:</b> You cannot specify any special character except underscore (_) in the rule type.	Yes
Rule Type Description	Used to specify the description for the rule type.	Yes

Field Name	Field Description	Mandatory (Yes or No)
Rule Validation Algorithm	<p>Used to specify the validation algorithm that will be triggered when a rule is defined using the rule type.</p> <div data-bbox="586 289 1162 667" style="border: 1px solid black; padding: 5px;"> <p><b>Note:</b> This algorithm checks whether:</p> <ul style="list-style-type: none"> <li>• The values specified against the output parameters exist in the system</li> <li>• The same price item parameter (for example, PCD1_1_1_VAL) is not used multiple times for a division, account, and price item combination</li> </ul> <p>The <b>Search</b>  icon appears corresponding to this field. On clicking the <b>Search</b> icon, the <b>Algorithm Search</b> window appears.</p> </div>	No
Info String Algorithm	<p>Used to specify the algorithm that will generate the information string which appears in the <b>Transaction Information</b> column throughout the application.</p> <div data-bbox="586 810 1162 1062" style="border: 1px solid black; padding: 5px;"> <p><b>Note:</b> This algorithm concatenates the fields (related to the transaction) and delimiters specified as parameters in the algorithm.</p> <p>The <b>Search</b>  icon appears corresponding to this field. On clicking the <b>Search</b> icon, the <b>Algorithm Search</b> window appears.</p> </div>	No
Maximum Accounts to be charged	<p>Used to indicate the maximum number of accounts which can bear the charges for a transaction. The valid values are:</p> <ul style="list-style-type: none"> <li>• 01</li> <li>• 02</li> <li>• 03</li> <li>• 04</li> <li>• 05</li> <li>• 06</li> <li>• 07</li> <li>• 08</li> <li>• 09</li> <li>• 10</li> </ul> <div data-bbox="586 1682 1162 1759" style="border: 1px solid black; padding: 5px;"> <p><b>Note:</b> At present, the system supports maximum 10 accounts which can bear the charges for a transaction.</p> </div>	Yes

Field Name	Field Description	Mandatory (Yes or No)
Maximum Price Items to be mapped	<p>Used to indicate the maximum number of price items to which a transaction can be mapped for each account. The valid values are:</p> <ul style="list-style-type: none"><li>• 01</li><li>• 02</li><li>• 03</li><li>• 04</li><li>• 05</li><li>• 06</li><li>• 07</li><li>• 08</li><li>• 09</li><li>• 10</li></ul> <p><b>Note:</b> At present, the system supports maximum 10 price items to which a transaction can be mapped for each account.</p>	Yes

Field Name	Field Description	Mandatory (Yes or No)
Maximum Price Item Parameters	<p>Used to indicate the maximum number of parameters that can be used with each price item to determine the price item pricing. The valid values are:</p> <ul style="list-style-type: none"> <li>• 00</li> <li>• 01</li> <li>• 02</li> <li>• 03</li> <li>• 04</li> <li>• 05</li> <li>• 06</li> <li>• 07</li> <li>• 08</li> <li>• 09</li> <li>• 10</li> <li>• 11</li> <li>• 12</li> <li>• 13</li> <li>• 14</li> <li>• 15</li> </ul> <p><b>Note:</b> At present, the system supports maximum 15 parameters that can be used with each price item to determine the price item pricing.</p>	Yes

In addition, this screen contains the following two sections:

- **Input/Output Parameters** — Enables you to select the transaction detail fields that you can use as input or output parameter while defining a rule. It contains the following fields:

Field Name	Field Description	Mandatory (Yes or No)
Rule Input/Output	Used to indicate whether you want to use the transaction detail field as input or output parameter.	No
Transaction Field	Displays the transaction field name.	Not applicable
Business Label	<p>Used to specify a business label for the user defined fields.</p> <p><b>Note:</b> The business label appears when you add, copy, or view a transaction in the <b>Transaction Details</b> screen. The label changes depending on the transaction source and record type combination that you have selected.</p>	No

**Note:** At present, you can use the following transaction fields as input or output parameter while defining a rule — Account Identifier (ACCT\_NBR), Account Identifier Type (ACCT\_NBR\_TYPE\_CD), Division (CIS\_DIVISION), Currency Code (CURRENCY\_CD), Customer Reference Number (CUST\_REF\_NBR), Do not Aggregate Switch (DO\_NOT\_AGG\_SW), External Reference Number (EXT\_TXN\_NBR), Credit/Debit Indicator (HOW\_TO\_USE\_TXN\_FLG), Manual Entry (MANUAL\_SW), Transaction Amount (TXN\_AMT), Transaction Date (TXN\_DTTM), Transaction Record Type (TXN\_REC\_TYPE\_CD), Transaction Source (TXN\_SOURCE\_CD), Transaction Upload Date (TXN\_UPLOAD\_DTTM), Transaction Volume (TXN\_VOL), Additional Amount 1 (UDF\_AMT\_1), Additional Amount 2 (UDF\_AMT\_2), Additional Amount 3 (UDF\_AMT\_3), Additional Amount 4 (UDF\_AMT\_4), Additional Amount 5 (UDF\_AMT\_5), Additional Amount 6 (UDF\_AMT\_6), Additional Amount 7 (UDF\_AMT\_7), Additional Amount 8 (UDF\_AMT\_8), Additional Amount 9 (UDF\_AMT\_9), Additional Amount 10 (UDF\_AMT\_10), Additional Data 1 (UDF\_CHAR\_1), Additional Data 2 (UDF\_CHAR\_2), Additional Data 3 (UDF\_CHAR\_3), Additional Data 4 (UDF\_CHAR\_4), Additional Data 5 (UDF\_CHAR\_5), Additional Data 6 (UDF\_CHAR\_6), Additional Data 7 (UDF\_CHAR\_7), Additional Data 8 (UDF\_CHAR\_8), Additional Data 9 (UDF\_CHAR\_9), Additional Data 10 (UDF\_CHAR\_10), Additional Data 11 (UDF\_CHAR\_11), Additional Data 12 (UDF\_CHAR\_12), Additional Data 13 (UDF\_CHAR\_13), Additional Data 14 (UDF\_CHAR\_14), Additional Data 15 (UDF\_CHAR\_15), Additional Data 16 (UDF\_CHAR\_16), Additional Data 17 (UDF\_CHAR\_17), Additional Data 18 (UDF\_CHAR\_18), Additional Data 19 (UDF\_CHAR\_19), Additional Data 20 (UDF\_CHAR\_20), Additional Data 21 (UDF\_CHAR\_21), Additional Data 22 (UDF\_CHAR\_22), Additional Data 23 (UDF\_CHAR\_23), Additional Data 24 (UDF\_CHAR\_24), Additional Data 25 (UDF\_CHAR\_25), Additional Data 26 (UDF\_CHAR\_26), Additional Data 27 (UDF\_CHAR\_27), Additional Data 28 (UDF\_CHAR\_28), Additional Data 29 (UDF\_CHAR\_29), Additional Data 30 (UDF\_CHAR\_30), Additional Data 31 (UDF\_CHAR\_31), Additional Data 32 (UDF\_CHAR\_32), Additional Data 33 (UDF\_CHAR\_33), Additional Data 34 (UDF\_CHAR\_34), Additional Data 35 (UDF\_CHAR\_35), Additional Data 36 (UDF\_CHAR\_36), Additional Data 37 (UDF\_CHAR\_37), Additional Data 38 (UDF\_CHAR\_38), Additional Data 39 (UDF\_CHAR\_39), Additional Data 40 (UDF\_CHAR\_40), Additional Data 41 (UDF\_CHAR\_41), Additional Data 42 (UDF\_CHAR\_42), Additional Data 43 (UDF\_CHAR\_43), Additional Data 44 (UDF\_CHAR\_44), Additional Data 45 (UDF\_CHAR\_45), Additional Data 46 (UDF\_CHAR\_46), Additional Data 47 (UDF\_CHAR\_47), Additional Data 48 (UDF\_CHAR\_48), Additional Data 49 (UDF\_CHAR\_49), Additional Data 50 (UDF\_CHAR\_50), Amount 1 Currency Code (UDF\_CURRENCY\_CD\_1), Amount 2 Currency Code (UDF\_CURRENCY\_CD\_2), Amount 3 Currency Code (UDF\_CURRENCY\_CD\_3), Amount 4 Currency Code (UDF\_CURRENCY\_CD\_4), Amount 5 Currency Code (UDF\_CURRENCY\_CD\_5), Amount 6 Currency Code (UDF\_CURRENCY\_CD\_6), Amount 7 Currency Code (UDF\_CURRENCY\_CD\_7), Amount 8 Currency Code (UDF\_CURRENCY\_CD\_8), Amount 9 Currency Code (UDF\_CURRENCY\_CD\_9), Amount 10 Currency Code (UDF\_CURRENCY\_CD\_10), Additional Date 1 (UDF\_DTTM\_1), Additional Date 2 (UDF\_DTTM\_2), Additional Date 3 (UDF\_DTTM\_3), Additional Date 4 (UDF\_DTTM\_4), Additional Date 5 (UDF\_DTTM\_5), Additional Numeric Data 1 (UDF\_NBR\_1), Additional Numeric Data 2 (UDF\_NBR\_2), Additional Numeric Data 3 (UDF\_NBR\_3), Additional Numeric Data 4 (UDF\_NBR\_4), Additional Numeric Data 5 (UDF\_NBR\_5), Additional Numeric Data 6 (UDF\_NBR\_6), Additional Numeric Data 7 (UDF\_NBR\_7), Additional Numeric Data 8 (UDF\_NBR\_8), Additional Numeric Data 9 (UDF\_NBR\_9), Additional Numeric Data 10 (UDF\_NBR\_10), Additional Numeric Data 11 (UDF\_NBR\_11), Additional Numeric Data 12 (UDF\_NBR\_12), Additional Numeric Data 13 (UDF\_NBR\_13), Additional Numeric Data 14 (UDF\_NBR\_14), Additional Numeric Data 15 (UDF\_NBR\_15), Additional Numeric Data 16 (UDF\_NBR\_16), Additional Numeric Data 17 (UDF\_NBR\_17), Additional Numeric Data 18 (UDF\_NBR\_18), Additional Numeric Data 19 (UDF\_NBR\_19), Additional Numeric Data 20 (UDF\_NBR\_20).

- **Temporary Fields** — Enables you to select non-transactional fields that you can use as input or output parameter while defining a rule. It contains the following fields:



Field Name	Field Description	Mandatory (Yes or No)
Temporary Field	Used to indicate the non-transactional field that you want to use as input or output parameter.  <b>Note:</b> The <b>Search</b> (🔍) icon appears corresponding to this field. On clicking the <b>Search</b> icon, the <b>Transaction Record Type Tempo Field Search</b> window appears.	No

- Enter the required details.

**Note:** You can search for an algorithm by clicking the **Search** (🔍) icon corresponding to the respective field.

- Select the check box corresponding to the transaction fields that you want to use as input or output parameters.
- If required, you can select a non-transactional field as input or output parameter in the **Temporary Fields** section.

**Note:**

You can search for a field by clicking the **Search** (🔍) icon corresponding to the respective field.

If you want to add more than one temporary field to the transaction record type, click the **Add** (+) icon and then repeat step 5. However, if you want to remove a temporary field from the transaction record type, click the

**Delete** (🗑️) icon corresponding to the temporary field.

- Click **Save**.

The new transaction record type is defined.

### Related Topics

For more information on...	See...
How to search for a transaction record type	<a href="#">Searching for a Transaction Record Type</a> on page 999

## Transaction Aggregation Rule

The **Transaction Aggregation Rule** screen allows you to define transaction aggregation rule for an SQL. You can also edit and delete the transaction aggregation rule of an SQL. This screen consists of the following zones:

- [Transaction Aggregation Rules](#) on page 1017

### Transaction Aggregation Rules

The **Transaction Aggregation Rules** zone lists transaction aggregation rules that are already defined in the system. You can define, edit, and delete a transaction aggregation rule through this zone.

This zone contains the following columns:

Column Name	Column Description
SQL Description	Displays the description of the service quantity identifier (SQI).
Aggregation Function	Indicates the formula used in the transaction aggregation rule defined for the SQI.
Function	Indicates the function used for aggregation.
Transaction Parameter	Indicates the transaction parameter used for aggregation.
Edit	On clicking the <b>Edit</b> (✎) icon, the <b>Transaction Aggregation Rule</b> screen appears where you can edit the aggregation rule.
Delete	On clicking the <b>Delete</b> (🗑) icon, you can delete the transaction aggregation rule.

You can define transaction aggregation rule for an SQI by clicking the **Add** link in the upper right corner of this zone. You can also change the layout of this zone. For more information on how to change the layout, see [Changing the Layout](#) on page 2882.

### **Related Topics**

For more information on...	See...
How to define transaction aggregation rule for an SQI	<a href="#">Defining Transaction Aggregation Rule for an SQI</a> on page 1018
How to edit transaction aggregation rule of an SQI	<a href="#">Editing Transaction Aggregation Rule of an SQI</a> on page 1019
How to delete transaction aggregation rule of an SQI	<a href="#">Deleting Transaction Aggregation Rule of an SQI</a> on page 1020

## **Defining Transaction Aggregation Rule for an SQI**

### **Prerequisites**

To define transaction aggregation rule for an SQI, you should have:

- SQI defined in the application

### **Procedure**

To define transaction aggregation rule for an SQI:

1. Click the **Admin** link in the **Application** toolbar.  
A list appears.
2. From the **Admin** menu, select **T** and then click **Transaction Aggregation Rule**.  
The **Transaction Aggregation Rule** screen appears.
3. Click the **Add** link in the upper right corner of the **Transaction Aggregation Rules** zone.  
The **Transaction Aggregation Rule** screen appears. It contains the following fields:

Field Name	Field Description	Mandatory (Yes or No)
SQL	Used to indicate the SQI for which you want to define the transaction aggregation rule.	Yes

Field Name	Field Description	Mandatory (Yes or No)
Function	Used to indicate the function that you want to use for aggregation. The valid values are: <ul style="list-style-type: none"> <li>SUM()</li> <li>MIN()</li> <li>MAX()</li> <li>COUNT()</li> </ul>	Yes
Transaction Parameter	Used to indicate the transaction parameter that you want to use for aggregation. The valid values are: <ul style="list-style-type: none"> <li>TXN_AMT</li> <li>TXN_VOL</li> <li>UDF_AMT_1, UDF_AMT_2, UDF_AMT_3, ..., UDF_AMT_10</li> <li>UDF_NBR_1, UDF_NBR_2, UDF_NBR_3, ..., UDF_NBR_20</li> </ul>	Yes

- Enter the required details.
- Click **Save**.

The transaction aggregation rule is defined for the SQI.

### Related Topics

For more information on...	See...
<b>Transaction Aggregation Rule</b> screen	<a href="#">Transaction Aggregation Rule</a> on page 1017
<b>Transaction Aggregation Rules</b> zone	<a href="#">Transaction Aggregation Rules</a> on page 1017

## Editing Transaction Aggregation Rule of an SQI

### Procedure

To edit the transaction aggregation rule of an SQI:

- Click the **Admin** link in the **Application** toolbar.  
A list appears.
- From the **Admin** menu, select **T** and then click **Transaction Aggregation Rule**.  
The **Transaction Aggregation Rule** screen appears.
- Click the **Edit**  icon in the **Edit** column corresponding to the SQI whose transaction aggregation rule you want to edit.

The **Transaction Aggregation Rule** screen appears. It contains the following fields:

Field Name	Field Description	Mandatory (Yes or No)
SQI	Indicates the SQI for which the transaction aggregation rule is defined.	Not applicable

Field Name	Field Description	Mandatory (Yes or No)
Function	Used to indicate the function that you want to use for aggregation. The valid values are: <ul style="list-style-type: none"> <li>SUM()</li> <li>MIN()</li> <li>MAX()</li> <li>COUNT()</li> </ul>	Yes
Transaction Parameter	Used to indicate the transaction parameter that you want to use for aggregation. The valid values are: <ul style="list-style-type: none"> <li>TXN_AMT</li> <li>TXN_VOL</li> <li>UDF_AMT_1, UDF_AMT_2, UDF_AMT_3, ..., UDF_AMT_10</li> <li>UDF_NBR_1, UDF_NBR_2, UDF_NBR_3, ..., UDF_NBR_20</li> </ul>	Yes

4. Modify the required details.

5. Click **Save**.

The changes made to the transaction aggregation rule are saved.

### **Related Topics**

For more information on...	See...
<b>Transaction Aggregation Rule</b> screen	<a href="#">Transaction Aggregation Rule</a> on page 1017
<b>Transaction Aggregation Rules</b> zone	<a href="#">Transaction Aggregation Rules</a> on page 1017

## **Deleting Transaction Aggregation Rule of an SQI**

### **Procedure**

To delete the transaction aggregation rule of an SQI:

1. Click the **Admin** link in the **Application** toolbar.

A list appears.

2. From the **Admin** menu, select **T** and then click **Transaction Aggregation Rule**.

The **Transaction Aggregation Rule** screen appears.

3. Click the **Delete** (🗑) icon in the **Delete** column corresponding to the SQI whose transaction aggregation rule you want to delete.

A message appears confirming whether you want to delete the transaction aggregation rule.

4. Click **OK**.

The transaction aggregation rule is deleted.

### **Related Topics**

For more information on...	See...
Transaction Aggregation Rule screen	<a href="#">Transaction Aggregation Rule</a> on page 1017
Transaction Aggregation Rules zone	<a href="#">Transaction Aggregation Rules</a> on page 1017

## Schedule

The **Schedule** screen allows you to define, edit, and delete a schedule. This screen consists of the following zones:

- [Search Schedule](#) on page 1021



### Search Schedule

The **Search Schedule** zone allows you to search for a schedule. This zone contains the following two sections:

- **Search Criteria** — The **Search Criteria** section contains the following fields:

Field Name	Field Description	Mandatory (Yes or No)
Schedule	Used to search a particular schedule.	No
Description	Used to search schedules with a particular .description	No

- **Search Results** — On clicking the **Search** button, the search results appear based on the specified search criteria. The **Search Results** section contains the following columns:

Column Name	Column Description
Schedule	Displays the schedule.
Description	Displays the description of the schedule.
View	On clicking the <b>View</b>  icon, the <b>View Schedule</b> screen appears where you can view the details of the schedule.
Edit	On clicking the <b>Edit</b>  icon, the <b>Edit Schedule</b> screen appears where you can edit the details of the schedule.
Delete	On clicking the <b>Delete</b>  icon, you can delete the schedule.
	<b>Note:</b> You can only delete a schedule which is not yet used.

You can create a new schedule by clicking the **Add** link in the upper right corner of this zone.

### Related Topics

For more information on...	See...
How to search for a schedule	<a href="#">Searching for a Schedule</a> on page 1022
How to view the details of a schedule	<a href="#">Viewing the Schedule Details</a> on page 1022
How to define a schedule	<a href="#">Defining a Schedule</a> on page 1023
How to edit a schedule	<a href="#">Editing a Schedule</a> on page 1024

For more information on...	See...
How to delete a schedule	<a href="#">Deleting a Schedule</a> on page 1025

## Searching for a Schedule

### Procedure

To search for a schedule:

1. Click the **Admin** link in the **Application** toolbar.  
A list appears.
2. From the **Admin** menu, select **S** and then click **Schedule**.  
The **Schedule** screen appears.
3. Enter the search criteria in the **Search Schedule** zone.

**Note:** ORMB search engine supports wildcard search, where you can substitute the percentage (%) symbol as a stand in for any word or letter in a search criteria. You can use the '%' wildcard character in all input fields except the date and ID fields. The '%' wildcard character is suffixed automatically at the end of the partial search criteria. Therefore, you may or may not specify the wildcard character at the end of the partial search criteria. However, you have to prefix the wildcard character manually wherever required.

4. Click **Search**.  
The search results appear.

### Related Topics

For more information on...	See...
<b>Schedule</b> screen	<a href="#">Schedule</a> on page 1021
<b>Search Schedule</b> zone	<a href="#">Search Schedule</a> on page 1021

## Viewing the Schedule Details

### Procedure

To view the details of a schedule:

1. Search for the schedule in the **Schedule** screen.
2. In the **Search Results** section, click the **View**  icon in the **View** column corresponding to the schedule whose details you want to view.  
The **View Schedule** screen appears.
3. View the details of the schedule in the **View Schedule** screen.

### Related Topics

For more information on...	See...
How to search for a schedule	<a href="#">Searching for a Schedule</a> on page 1022

## Defining a Schedule

### Procedure

To define a schedule:

1. Click the **Admin** link in the **Application** toolbar.

A list appears.

2. From the **Admin** menu, select **S** and then click **Schedule**.

The **Schedule** screen appears.

3. Click the **Add** link in the upper right corner of the **Search Schedule** zone.

The **Add Schedule** screen appears. It contains the following fields:

Field Name	Field Description	Mandatory (Yes or No)
Schedule	Used to specify the schedule code.	Yes
Description	Used to specify the description for the schedule.	Yes

In addition, this screen contains the following two sections:

- **Schedule Periods** — This section contains the following fields:

Field Name	Field Description	Mandatory (Yes or No)
Start Date	Used to specify the start date of the schedule period. <b>Note:</b> The start date cannot be later than the end date.	Yes
End Date	Used to specify the end date of the schedule period. <b>Note:</b> The end date cannot be earlier than the start date.	Yes

**Note:** At least one schedule period must be defined in the schedule. Also, ensure that the schedule periods do not have overlapping days.

- **Schedule Types** — This section contains the following fields:

Field Name	Field Description	Mandatory (Yes or No)
Schedule Type	Used to indicate the functionality where you want to use the schedule. You can use a schedule for more than one functionality.	Yes

4. Enter the required details.

- 5.

If you want to define more than one period in the schedule, click the **Add** () icon and then specify the details.

**Note:** However, if you want to remove a period from the schedule, click the **Delete** () icon corresponding to the period.

6. Click **Save**.

The schedule is defined.

### Related Topics

For more information on...	See...
Schedule screen	<a href="#">Schedule</a> on page 1021
Search Schedule zone	<a href="#">Search Schedule</a> on page 1021

## Editing a Schedule

### Procedure

To edit a schedule:

1. Search for the schedule in the **Schedule** screen.
2. In the **Search Results** section, click the **Edit**  icon in the **Edit** column corresponding to the schedule whose details you want to edit.

The **Edit Schedule** screen appears. It contains the following fields:

Field Name	Field Description	Mandatory (Yes or No)
Schedule	Displays the schedule code.	Not applicable
Description	Used to specify the description for the schedule.	Yes

In addition, this screen contains the following two sections:

- **Schedule Periods** — This section contains the following fields:

Field Name	Field Description	Mandatory (Yes or No)
Start Date	Used to specify the start date of the schedule period.  <b>Note:</b> The start date cannot be later than the end date.	Yes
End Date	Used to specify the end date of the schedule period.  <b>Note:</b> The end date cannot be earlier than the start date.	Yes

**Note:** At least one schedule period must be defined in the schedule. Also, ensure that the schedule periods do not have overlapping days.

- **Schedule Types** — This section contains the following fields:

Field Name	Field Description	Mandatory (Yes or No)
Schedule Type	Used to indicate the functionality where you want to use the schedule. You can use a schedule for more than one functionality.	Yes



3. Modify the required details.
4. If you want to define more than one period in the schedule, click the **Add** () icon and then specify the details.

**Note:** However, if you want to remove a period from the schedule, click the **Delete** () icon corresponding to the period.

5. Click **Save**.

The changes made to the schedule are saved.

#### **Related Topics**

For more information on...	See...
How to search for a schedule	<a href="#">Searching for a Schedule</a> on page 1022

## Deleting a Schedule

### **Procedure**

To delete a schedule:

1. Search for the schedule in the **Schedule** screen.
2. In the **Search Results** section, click the **Delete** () icon in the **Delete** column corresponding to the schedule that you want to delete.

A message appears confirming whether you want to delete the schedule.

**Note:** You can only delete a schedule which is not yet used.

3. Click **OK**.

The schedule is deleted.

#### **Related Topics**

For more information on...	See...
How to search for a schedule	<a href="#">Searching for a Schedule</a> on page 1022

## Disaggregation Request

Through the **Disaggregation Request Creation (C1-DISTG)** batch, you can only create a disaggregation request for an account. However, from the **Disaggregation Request** screen, you can create a disaggregation request for a person and account. When you create a disaggregation request for a person, the system does not create the disaggregation request for the person. Instead, the system creates the disaggregation request for all accounts of the person (where the person is the main customer) and its child persons.

The **Disaggregation Request** screen allows you to search for disaggregation requests using various search criteria. It also allows you to create and delete a disaggregation request. This screen consists of the following zone:

- [Search Disaggregation Request](#) on page 1026

## Search Disaggregation Request

The **Search Disaggregation Request** zone allows you to search for a disaggregation request using various search criteria. It contains the following two sections:

- **Search Criteria** - The **Search Criteria** section contains the following fields:

Field Name	Field Description	Mandatory (Yes or No)
Search By	Used to indicate whether you want to search for a disaggregation request using the person, account, or accumulation group details. The valid values are: <ul style="list-style-type: none"> <li>• Person</li> <li>• Account</li> <li>• Accumulation Group</li> </ul> <p><b>Note:</b> By default, the <b>Person</b> option is selected.</p>	Yes
Person Name	Used to search disaggregation requests which are created for accounts belonging to persons with a particular name. <p><b>Note:</b> This field appears only when the <b>Person</b> option is selected from the <b>Search By</b> list.</p>	No
Person ID	Used to search disaggregation requests which are created for accounts of a particular person. <p><b>Note:</b> This field appears only when the <b>Person</b> option is selected from the <b>Search By</b> list.</p>	No
Request Date From	Used to search disaggregation requests which are created from a particular date onwards.	Yes
Person Identifier	Used to search disaggregation requests which are created for accounts of a particular person. <p><b>Note:</b> This field appears only when the <b>Person</b> option is selected from the <b>Search By</b> list.</p>	Yes (Conditional) <p><b>Note:</b> If you specify the person identifier type as a search criteria, you have to specify the person identifier.</p>
Request Date To	Used to search disaggregation requests which are created till a particular date.	Yes
Person Identifier Type	Used to indicate the person identifier type. <p><b>Note:</b> This field appears only when the <b>Person</b> option is selected from the <b>Search By</b> list.</p>	Yes (Conditional) <p><b>Note:</b> If you specify the person identifier as a search criteria, you have to select the person identifier type.</p>

Field Name	Field Description	Mandatory (Yes or No)
Processing Date From	Used to search disaggregation requests which are processed from a particular date onwards.	No
Request Source	Used to search disaggregation requests which are created automatically, manually, or through the batch process. The valid values are: <ul style="list-style-type: none"> <li>• AUTOMATIC</li> <li>• BATCH</li> <li>• MANUAL</li> </ul>	No
Processing Date To	Used to search disaggregation requests which are processed till a particular date.	No
Request Status	Used to search disaggregation requests with a particular status. The valid values are: <ul style="list-style-type: none"> <li>• COMPLETE</li> <li>• PENDING</li> </ul>	No
Request Type	Used to search disaggregation requests with a particular request type. The valid values are: <ul style="list-style-type: none"> <li>• Account</li> <li>• Billable Charge</li> <li>• Price Assignment</li> <li>• Price Item</li> </ul> <div style="border: 1px solid black; padding: 2px; margin-top: 5px;"> <b>Note:</b> This field appears only when the <b>Person</b> or <b>Account</b> option is selected from the <b>Search By</b> list. </div>	No
Division	Used to search disaggregation requests which are created for accounts belonging to a particular division. <div style="border: 1px solid black; padding: 2px; margin-top: 5px;"> <b>Note:</b>  You can only view those divisions to which you have access in the <b>Division</b> list.   This field appears only when the <b>Person</b> or <b>Account</b> option is selected from the <b>Search By</b> list. </div>	Yes (Conditional) <div style="border: 1px solid black; padding: 2px; margin-top: 5px;"> <b>Note:</b> This field is required when you are searching for a disaggregation request using the account details. </div>
Account ID	Used to search disaggregation requests which are created for a particular account. <div style="border: 1px solid black; padding: 2px; margin-top: 5px;"> <b>Note:</b> This field appears only when you select the <b>Account</b> option from the <b>Search By</b> list. </div>	No

a

Field Name	Field Description	Mandatory (Yes or No)
Account Identifier	Used when you want to search disaggregation requests created for an account.  <b>Note:</b> This field appears only when you select the <b>Account</b> option from the <b>Search By</b> list.  a	Yes (Conditional)  <b>Note:</b> If you specify account identifier type as a search criteria, you have to enter the account identifier.
Account Identifier Type	Used to select the account identifier type based on which you want to search disaggregation requests created for an account.  <b>Note:</b> This field appears only when you select the <b>Account</b> option from the <b>Search By</b> list.  a	Yes (Conditional)  <b>Note:</b> If you enter account identifier as a search criteria, you have to select the account identifier type.
Accumulation Type	Used to select the accumulation type based on which you want to search disaggregation requests created for an accumulation group.  <b>Note:</b> This field appears only when you select the <b>Accumulation Group</b> option from the <b>Search By</b> list.	No
Parent Accumulation Group ID	Used to select the parent accumulation group id based on which you want to disaggregation requests created for an accumulation group.	Yes (Conditional)  <b>Note:</b> If you enter accumulation type as a search criteria, you have to select the parent accumulation group id.

- **Search Results** - The **Search Results** section displays the records based on the specified search criteria. The columns in the search results change depending on the query option selected.

Column Name	Column Description
Request ID	Displays the disaggregation request ID.
Request Date	Displays the date when the disaggregation request was created.
Status	Indicates the status of the disaggregation request. The valid values are: <ul style="list-style-type: none"> <li>• COMPLETE</li> <li>• PENDING</li> </ul>
Person ID	Indicates the person for whom the disaggregation request is created.

Column Name	Column Description
Person Information	<p>Displays additional information about the person. In addition, this column has a context menu which helps in navigating to other screens in the application.</p> <p><b>Note:</b> It has a link. On clicking the link, the <b>Person</b> screen appears with the details of the respective person.</p>
Account ID	Indicates the account for which the disaggregation request is created.
Account Information	<p>Displays additional information about the account. In addition, this column has a context menu which helps in navigating to other screens in the application.</p> <p><b>Note:</b> It has a link. On clicking the link, the <b>Account</b> screen appears with the details of the respective account. This column appears only when you select the <b>Account</b> option from the <b>Search By</b> list.</p>
Processing Date	Displays the date when the disaggregation request is processed.
Request Type	Displays the request type based on which the disaggregation request is processed.
Price Item	Displays the price item using which the disaggregation request is processed.
Pricing	Displays the pricing details using which the disaggregation request is processed.
Billable Charge ID	Displays the charge id billable for the processed disaggregation request.
Delete	<p>On clicking the <b>Delete</b> button, you can delete the disaggregation request.</p> <p><b>Note:</b> You can only delete a disaggregation request which is in the <b>Pending</b> status.</p>

You can create a disaggregation request manually by clicking the **Add** link in the upper right corner of this zone.

### **Related Topics**

For more information on...	See...
How to search for a disaggregation request	<a href="#">Searching for a Disaggregation Request</a> on page 1029
How to create a disaggregation request manually	<a href="#">Creating a Disaggregation Request</a> on page 1030
How to delete a disaggregation request	<a href="#">Deleting a Disaggregation Request</a> on page 1035

## **Searching for a Disaggregation Request**

### **Procedure**

To search for a disaggregation request:

1. Click the **Menu** link in the **Application** toolbar.  
A list appears.
2. From the **Main** menu, select **Transaction Feed Management** and then click **Disaggregation Request**.  
The **Disaggregation Request** screen appears.
3. Enter the search criteria in the **Search Disaggregation Request** zone.

**Note:** ORMB search engine supports wildcard search, where you can substitute the percentage (%) symbol as a stand in for any word or letter in a search criteria. You can use the ‘%’ wildcard character in all input fields except the date and ID fields. The ‘%’ wildcard character is suffixed automatically at the end of the partial search criteria. Therefore, you may or may not specify the wildcard character at the end of the partial search criteria. However, you have to prefix the wildcard character manually wherever required.

#### 4. Click **Search**.

A list of disaggregation requests that meet the search criteria appears in the **Search Results** section.

#### Related Topics

For more information on...	See...
<b>Disaggregation Request</b> screen	<a href="#">Disaggregation Request</a> on page 1025
<b>Search Disaggregation Request</b> zone	<a href="#">Search Disaggregation Request</a> on page 1026

## Creating a Disaggregation Request

### Prerequisites

To create a disaggregation request manually, you should have:

- Divisions, person identifier types, account identifier types, bill cycles, and invoice currencies defined in the application
- Price list assigned to the person or account (in case you want to search a person or an account based on an assigned price list)

### Procedure

To create a disaggregation request manually:

1. Click the **Menu** link in the **Application** toolbar.

A list appears.

2. From the **Main** menu, select **Transaction Feed Management** and then click **Disaggregation Request**.

The **Disaggregation Request** screen appears.

3. Click the **Add** link in the upper right corner of the **Search Disaggregation Request** zone.

The **Add Disaggregation Request** screen appears. It contains the following field:

Field Name	Field Description	Mandatory (Yes or No)
Request Type	Used to indicate whether you want to create disaggregation request for a person or an account. The valid values are: <ul style="list-style-type: none"> <li>• Parent Accumulation Group</li> <li>• Person/Account</li> </ul>	Yes

4. Click **OK**.

The **Add Disaggregation Request** screen appears. It contains the following fields:

Request Type	Used to indicate whether you want to create disaggregation request for a person or an account. The valid values are: <ul style="list-style-type: none"> <li>Account</li> <li>Person</li> </ul>	
Division	Used to specify the division to which the person or account belongs.  <b>Note:</b> You can only view those divisions to which you have access in the <b>Division</b> list.	Yes (Conditional)  <b>Note:</b> This field is required when you are creating a disaggregation request for an account.
Account ID	Used to indicate the account for which you want to create a disaggregation request.  <b>Note:</b> This field is enabled only when you select the <b>Account</b> option from the <b>Request Type</b> list.	No
Person ID	Used to indicate the person for whom you want to create a disaggregation request.  <b>Note:</b> This field is enabled only when you select the <b>Person</b> option from the <b>Request Type</b> list.	No
Account Identifier Type	Used to specify the account identifier type based on which you want to search for an account.  <b>Note:</b> This field is enabled only when you select the <b>Account</b> option from the <b>Request Type</b> list.	Yes (Conditional)  <b>Note:</b> If you enter account identifier as a search criteria, you have to select the account identifier type.
Account Identifier	Used to indicate the account for which you want to create a disaggregation request.  <b>Note:</b> This field is enabled only when you select the <b>Account</b> option from the <b>Request Type</b> list.	Yes (Conditional)  <b>Note:</b> If you specify account identifier type as a search criteria, you have to enter the account identifier.
Person Identifier Type	Used to specify the person identifier type based on which you want to search for a person.  <b>Note:</b> This field is enabled only when you select the <b>Person</b> option from the <b>Request Type</b> list.	Yes (Conditional)  <b>Note:</b> If you enter person identifier as a search criteria, you have to select the person identifier type.

Person Identifier	Used to indicate the person for whom you want to create a disaggregation request.  <b>Note:</b> This field is enabled only when you select the <b>Person</b> option from the <b>Request Type</b> list.	Yes (Conditional)  <b>Note:</b> If you specify person identifier type as a search criteria, you have to enter the person identifier.
Bill Cycle	Used when you want to search accounts having a particular bill cycle.  <b>Note:</b> This field is enabled only when you select the <b>Account</b> option from the <b>Request Type</b> list.	No
Person Name	Used to specify the name of the person.	No
Invoice Currency	Used when you want to search accounts having a particular invoice currency.  <b>Note:</b> This field is enabled only when you select the <b>Account</b> option from the <b>Request Type</b> list.	No
With Assigned Price List	Used when you want to search for a person or an account to which a particular price list is assigned.	Yes (Conditional)  <b>Note:</b> This field is required when you want to search for a person or an account based on an assigned price list.
Price List Assigned From	Used when you want to search for a person or an account based on an assigned price list which is effective within the specified date range.	Yes (Conditional)  <b>Note:</b> This field is required when you want to search for a person or an account based on an assigned price list.
Price List Assigned To	Used when you want to search for a person or an account based on an assigned price list which is effective within the specified date range.	Yes (Conditional)  <b>Note:</b> This field is required when you want to search for a person or an account based on an assigned price list.

5. Select the **Person** or **Account** option from the **Request Type** list depending on whether you want to search for a person or an account.
6. Enter the search criteria in the **Search** section.



**Note:**

Pagination is used to display limited number of records in the **Search Results** section. By default, 20 records are displayed in the **Search Results** section. You can change the number of records displayed per page, if required.

You can use the navigation buttons, such as **First** ( << ), **Previous** ( < ), **Next** ( > ), and **Last** ( >> ) to navigate between pages. You can also select the page to which you want to navigate from the **Go To** list.

The values appear in the **Page Limit** list only when you define values for the **PAGE\_NUMBER** lookup field.

**Note:** ORMB search engine supports wildcard search, where you can substitute the percentage (%) symbol as a stand in for any word or letter in a search criteria. You can use the ‘%’ wildcard character in all input fields except the date and ID fields. The ‘%’ wildcard character is suffixed automatically at the end of the partial search criteria. Therefore, you may or may not specify the wildcard character at the end of the partial search criteria. However, you have to prefix the wildcard character manually wherever required.

## 7. Click **Search**.

A list of persons or accounts that meet the search criteria appears in the **Search Results** section. It contains the following columns:

Column Name	Column Description
Account Identifier Type	Displays the primary account identifier type of the account. <b>Note:</b> The data appears in this column only when you search for an account.
Account Identifier	Displays the value of the primary account identifier type. <b>Note:</b> The data appears in this column only when you search for an account.
Division	Displays the division to which the person or account belongs.
Person Identifier Type	Displays the primary person identifier type of the person. <b>Note:</b> The data appears in this column only when you search for a person.
Person Identifier	Displays the value of the primary person identifier type. <b>Note:</b> The data appears in this column only when you search for a person.
Person Name	Displays the name of the person.
With Assigned Price List	Displays the price list assigned to the person or account. <b>Note:</b> The data appears in this column only when you search for a person or an account based on an assigned price list.
Price List Assigned From	Displays the date from when the price list is assigned to the person or account. <b>Note:</b> The data appears in this column only when you search for a person or an account based on an assigned price list.
Price List Assigned To	Displays the date till when the price list is assigned to the person or account. <b>Note:</b> The data appears in this column only when you search for a person or an account based on an assigned price list.

Column Name	Column Description
Account Info	Displays additional information about the account. <b>Note:</b> The data appears in this column only when you search for an account.
Bill Cycle	Indicates the bill cycle defined for the account. <b>Note:</b> The data appears in this column only when you search for an account.

**Note:**

Pagination is used to display limited number of records in the **Search Results** section. By default, 20 records are displayed in the **Search Results** section. You can change the number of records displayed per page, if required.

You can use the navigation buttons, such as **First** ( << ), **Previous** ( < ), **Next** ( > ), and **Last** ( >> ) to navigate between pages. You can also select the page to which you want to navigate from the **Go To** list.

The values appear in the **Page Limit** list only when you define values for the **PAGE\_NUMBER** lookup field.

8. Do either of the following:

If you want to...	Then...
Create disaggregation request for one or more persons or accounts	<ol style="list-style-type: none"> <li>1. In the <b>Search Results</b> section, select the check box corresponding to the person or account for which you want to create a disaggregation request.</li> <li>2. Click <b>Disaggregate</b>.</li> </ol> <p>If you have selected an account, the disaggregation request is created for the account. However, if you have selected a person, the disaggregation request is created for each account of the person (where the person is the main customer) and its child person.</p>
Create disaggregation request for all persons or accounts that meet the search criteria	<ol style="list-style-type: none"> <li>1. Click <b>Disaggregate All</b>.</li> </ol> <p>A message appears confirming whether you want to create disaggregation requests for all persons or accounts that meet the search criteria.</p> <ol style="list-style-type: none"> <li>2. Click <b>OK</b>.</li> </ol> <p>If the accounts are listed in the <b>Search Results</b> section, the disaggregation request is created for each account (listed on the respective page). However, if the persons are listed in the <b>Search Results</b> section, the disaggregation request is created for each account of the person (where the person is the main customer) and its child person.</p>

**Related Topics**

For more information on...	See...
<b>Disaggregation Request</b> screen	<a href="#">Disaggregation Request</a> on page 1025

For more information on...	See...
Search Disaggregation Request zone	<a href="#">Search Disaggregation Request</a> on page 1026

## Deleting a Disaggregation Request

### Procedure

To delete a disaggregation request:

1. Search for the disaggregation request in the **Disaggregation Request** screen.
2. In the **Search Results** section, click the **Delete** button available in the **Delete** column corresponding to the disaggregation request that you want to delete.

A message appears confirming whether you want to delete the disaggregation request.

#### **Note:**

You can only delete a disaggregation request which is in the **Pending** status.

If the disaggregation process is already started for a disaggregation request, we recommend you not to delete the disaggregation request from the system. Otherwise, erroneous results might occur.

3. Click **OK**.

The disaggregation request is deleted.

### Related Topics

For more information on...	See...
How to search for a disaggregation request	<a href="#">Searching for a Disaggregation Request</a> on page 1029
Search zone	<a href="#">Search Disaggregation Request</a> on page 1026

## Accumulation Data

---

The information will be available shortly!



---

# Chapter 12

---

## Upload Validated Payment Data

---

### Topics:

- [Payment Upload Process](#)
- [Prerequisites](#)
- [CSV File Format](#)
- [Payment Data File Status Transition](#)
- [Payment Record Status Transition](#)
- [Error Messages](#)
- [Payment Upload](#)

Oracle Revenue Management and Billing until now provided you with an ability to interface payments from an external source, such as remittance processor. The system supported two mechanisms to upload payment data — one using which you can populate payment upload staging records and another using which you can populate payment event upload staging records. The system now enables you to validate the payment records before you move them to the staging area. The system provides the pre-staging area where you can upload and validate the payment records. The system provides a user interface which helps you to upload a payment data file in the pre-staging area. It also helps you to perform various tasks, such as:

- Track the status of the payment records and the payment data file
- Move the payment records to the staging area
- Cancel a payment data file
- View the log of a payment data file

You can upload a payment data file in the CSV format. You need to ensure that the CSV file is in the required format; otherwise the file will not be uploaded in the system. For more information about the CSV file format, see [CSV File Format](#) on page 1041. At present, the system supports only the CSV file format. This is because the payment data mapping algorithm type shipped with the product is designed to support the CSV format. If you want to use any other file format, you need to define custom mapping algorithm type that supports the required file format.

The file type using which you upload a payment data file indicates the mapping and validation algorithms that you want to use for the payment data file. On uploading a payment data file, the mapping algorithm parses the CSV file and uploads the payments records in the pre-staging area. The validation process starts immediately after the file is uploaded in the system. During the validation process, the system and custom validations (if any) are executed. Once the validation process is complete, you can move the payment records from the pre-staging to staging area. Once the payment records are moved to the staging area, the system creates payment events, tenders, payments and payment segments through a batch process. For more information about the payment upload process, see [Payment Upload Process](#) on page 1038.

During the payment upload process, a payment data file and each record of the file goes through various statuses until the payment events and payments are created. For more information about the payment data file and payment record statuses, see [Payment Data File Status Transition](#) on page 1043 and [Payment Record Status Transition](#) on page 1043, respectively.

## Payment Upload Process

---

The payment upload process includes the following sub-processes:

- [Upload Payment Records in the Pre-Staging Area](#) on page 1038
- [Move Payment Records to the Staging Area](#) on page 1039
- [Create Payment Events and Payments](#) on page 1039

### Upload Payment Records in the Pre-Staging Area

Oracle Revenue Management and Billing allows you to validate the payment records before you move them to the staging area. You can upload and validate the payment records in the pre-staging area. You can upload a payment data file in the CSV format. You need to ensure that the CSV file is in the required format; otherwise the file will not be uploaded in the system. For more information about the CSV file format, see [CSV File Format](#) on page 1041.

While uploading a payment data file, you need to specify the file type using which you want to upload the payment data file. The file type indicates the mapping and validation algorithms that you want to use for the payment data file. Therefore, while defining a file type using which you want to upload a payment data file, you need to:

- Set the feed type to **Payment Upload Data**
- Attach mapping algorithm which is created using the **C1-CSVUPLPAY** algorithm type
- Attach validation algorithm which is created using the **C1-PUPLVALID** algorithm type

On uploading a payment data file, the mapping algorithm does the following:

1. Validates whether the file is in the CSV format
2. Validates whether at least one payment record is available in the CSV file
3. Parses the flat file in the CSV format and maps the columns in the CSV file to various tables in the database
4. Uploads the payments records in the pre-staging area

The validation process starts immediately after the payment data file is uploaded in the system. During the validation process, the system and custom validations (if any) are executed. The system checks whether:

- The data is available in the **Tender ID, Tender Amount, Payment Amount, Date Received, Bank Account, and Payment Type** columns in the CSV file.
- The data is available in the **Match Type** and **Match Value** columns in the CSV file.

**Note:** This validation is done only when the **Is Match Type Validation Required (Y/N)** parameter is set to **Y** in the validation algorithm.

- The payee and payor accounts specified in the payment record exists in the system.
- The payee account with the specified account identifier type and account identifier combination exists in the system.
- A valid currency code is specified in the payment record.

**Note:** If the currency code is not specified, the currency is set to the payor account's invoice currency.

- The payment type (i.e. tender type) specified in the payment record exists in the system.
- The account identifier type specified in the payment record exists in the system.

**Note:** This validation is done only when the payee account ID is not specified in the payment record.

- The match type specified in the payment record exists in the system.

**Note:** This validation is done only when the **Is Match Type Validation Required (Y/N)** parameter is set to **Y** in the validation algorithm.

- The characteristic type specified in the payment record exists in the system.
- The characteristic value matches any predefined value when the characteristic value type is set to **Predefined Value**.
- The characteristic value is specified in the payment record when the characteristic type is specified and vice-versa.

You can upload a file by clicking the **Upload** link in the **Payment Upload** screen. On uploading a payment data file, the payment records are copied to the pre-staging area and the status of the payment data file is set to **Pending**. The validation process starts immediately after the payment data file is uploaded in the system. If a payment record is successfully validated, the status of the payment record is set to **Valid**. If a payment record contains incorrect or missing data, the status of the payment record is set to either **Invalid** or **Error** depending on the scenario. For more information about the scenarios when a payment record is set to the **Invalid** or **Error** status, see [Payment Record Status Transition](#) on page 1043.

Once the validation process is completed, the status of the payment data file is changed to **Validated**. Once the payment records are uploaded and validated in the pre-staging area, you can do either of the following:

- Move the payment records to the staging area
- Cancel a payment data file
- Replace the existing payment data file

**Note:** If a payment data file contains an invalid record, you need to correct or add missing data in the CSV file and then upload the file once again. Unless, a payment data file has no invalid records, you cannot move any record of the payment data file to the staging area.

## Move Payment Records to the Staging Area

Once the payment records are uploaded and validated in the pre-staging area, you can move the records to the staging area. The system allows you to move only valid and error records of a payment data file to the staging area. If a payment data file contains an invalid record, you cannot move any record of the payment data file to the staging area. In such scenario, you need to correct the invalid payment records and upload the same file once again in the system. In addition, if you have cancelled a payment data file, you cannot move any records (including valid and error records) of the payment data file to the staging area.

You can move the payment records to the staging area by clicking the **Move to Staging** icon corresponding to the payment data file in the **Payment Upload** screen. The **Move to Staging** icon appears only when:

- The status of the payment data file is **Validated**.
- There are no invalid records in the payment data file.
- The **Disable Move to Staging** check box is not selected in the respective file type.

On clicking the **Move to Staging** icon, the payment records are copied (and not moved) from the pre-staging to staging area and the status of the payment data file is changed to **In Staging**. In addition, the status of the payment records in the pre-staging area is changed to **In Staging** and the status of the deposit control, tender control, and payment tender staging records is set to **Pending**. Once you move the payment records to the staging area, you can edit the payment staging records, if required.

## Create Payment Events and Payments

Once the payment records are moved to the staging area, the system creates payment events for the payment data file in the background when the **Payment Upload (PUPL)** batch is invoked. You can configure the **Payment Upload (PUPL)** batch such that it is executed at regular intervals. When the **Payment Upload (PUPL)** batch is invoked, the

system checks whether there are any deposit control, tender control, payment tender, and payment staging records in the **Pending** status. If there are staging records in the **Pending** status, the system creates the following entities:

- Deposit Control
- Tender Control
- Payment Events
- Payment Tenders
- Payments
- Payment Segments
- Financial Transactions (when the payments are frozen)

The status of the deposit control, tender control, payment tender, and payment staging records is changed to **Complete**. If any error occurs while creating payment event for a payment record, the status of the deposit control, tender control, payment tender, and payment staging records is changed to **Error**. In addition, the status of the payment record in the pre-staging area is changed to **Error in Staging**.

Traditionally, the **Payment Upload (PUPL)** batch considered staging records which are in the **Error** or **Pending** status. If a staging record is in the **Error** status, the system used to reset the status to **Pending** and then further processed the staging record. This system behavior still exists for staging records which are not uploaded through the **Payment Upload** process. If the staging records are uploaded through the **Payment Upload** process, you need to manually correct the staging records and change the status of deposit control, tender control, payment tender, and payment staging records to **Pending**. The corrected staging records will then be processed when the **Payment Upload (PUPL)** batch is invoked at subsequent interval.

## Prerequisites

---

To setup the payment upload process, you need to do the following:

- Define the required match types with the appropriate payment distribution override and manual distribution algorithms.
- Define the required tender types in the system.
- Define the required currency codes in the system.
- Define the required tender sources in the system.
- Define the required characteristic types where the characteristic entity is set to **Payment**.
- Create a mapping algorithm using the **C1-CSVUPLPAY** algorithm type.
- Create a validation algorithm using the **C1-PUPLVALID** algorithm type.
- Define the required file types where the feed type is set to **Payment Upload Data**.
- Assign the **PUPL To Do** type to a To Do role whose users must receive the To Do generated while executing the **Payment Upload (PUPL)** batch.
- Set the batch control type of the **Payment Upload (PUPL)** batch to **Timed** and define the following attributes:
  - Time Interval
  - Timer Active
  - User ID
  - Batch Language
  - Email Address



## CSV File Format

Before uploading a payment data file, you need to ensure that the CSV file contains the following columns:

Column Name	Description	Mandatory (Yes or No)
Account ID	Used to specify the payee account ID.	Yes
Match Type	Used to specify the match type using which you want to match the payment.	Yes (Conditional) <b>Note:</b> This data is required when the match value is specified.
Match Value	Used to specify the entity (such as bill, contract, and so on) against which you want to match the payment.	Yes (Conditional) <b>Note:</b> This data is required when the match type is specified.
Tender ID	Used to specify the payment tender ID. <b>Note:</b> If the tender ID is same for two or more payment records, the system will create multiple payments against one tender. In other words, there will be multiple payments which are created through the payment event.	Yes
Tender Amount	Used to specify the tender amount. <b>Note:</b> You must not specify the value less than or equal to 0. The precision specified for the tender amount must not exceed the decimal places defined for the currency in the system.	Yes
Payment Amount	Used to specify the amount paid through the tender. <b>Note:</b> You must not specify the value less than or equal to 0. The precision specified for the payment amount must not exceed the decimal places defined for the currency in the system.	Yes
Date Received	Used to specify the date when the payment is made. <b>Note:</b> You must specify the date in the MM/DD/YYYY format.	Yes
Bank Account	Used to specify the external source ID which is associated with the tender source.	Yes

Column Name	Description	Mandatory (Yes or No)
Payment Type	Used to specify the type of tender through which the payment is made.	Yes
Check Number	Used to specify the check number if the payment is made through check.	No
Currency	Used to specify the currency in which the payment is made. <b>Note:</b> If the currency is not specified, it is set to the payor account's invoice currency.	No
Account ID Type	Used to specify the account identifier type.	Yes (Conditional) <b>Note:</b> This data is required when the account identifier is specified.
Account Identifier	Used to specify the account for which the payment is made.	Yes (Conditional) <b>Note:</b> This data is required when the account identifier type is specified.
Payment Char Type1, Payment Char Type2, ....., Payment Char Type5	Used to indicate the characteristic that must be defined for the payment.	Yes (Conditional) <b>Note:</b> This data is required when the characteristic value is specified.
Payment Char Value1, Payment Char Value2, ....., Payment Char Value5	Used to specify the value for the characteristic type.	Yes (Conditional) <b>Note:</b> This data is required when the characteristic type is specified.
MICR ID	Used to specify the MICR code.	No
Payor ID	Used to specify the payor account ID. <b>Note:</b> If the payor account ID is not specified, the payor account ID is set to the payee account ID assuming that the payor and payee are the same.	No

**Note:**

If a payment data file contains column names other than those mentioned in the above table, the system will not upload the payment data file.

If a payment data file contains more than 1000 payment records, the system will not allow you to upload the payment data file in the system. Therefore, ensure that a payment data file contains less than 1000 payment records.

## Payment Data File Status Transition

---

The following figure graphically indicates how a payment data file moves from one status to another during the payment upload process:

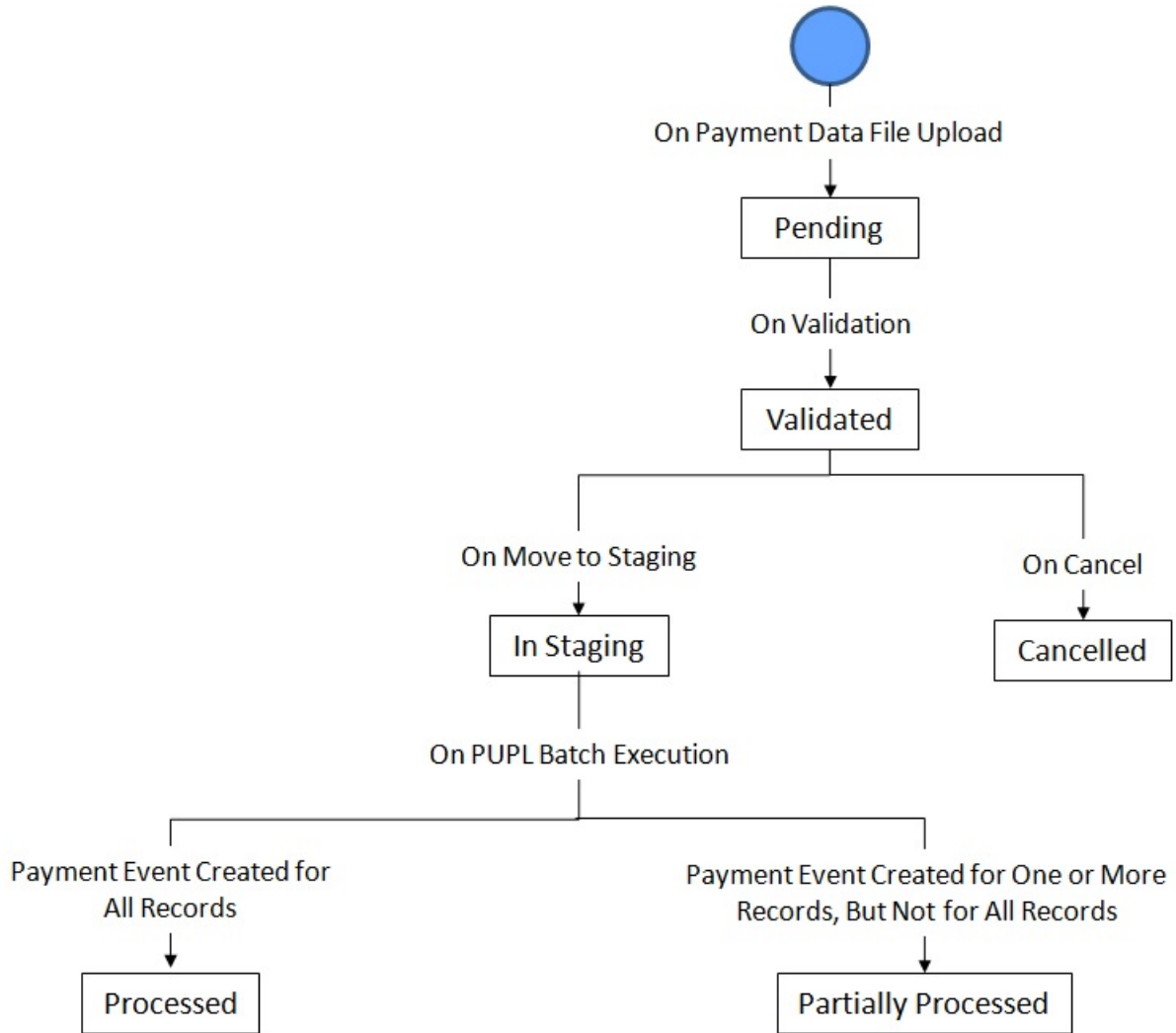

## Payment Record Status Transition

---

The following figure graphically indicates how a payment record moves from one status to another during the payment upload process:

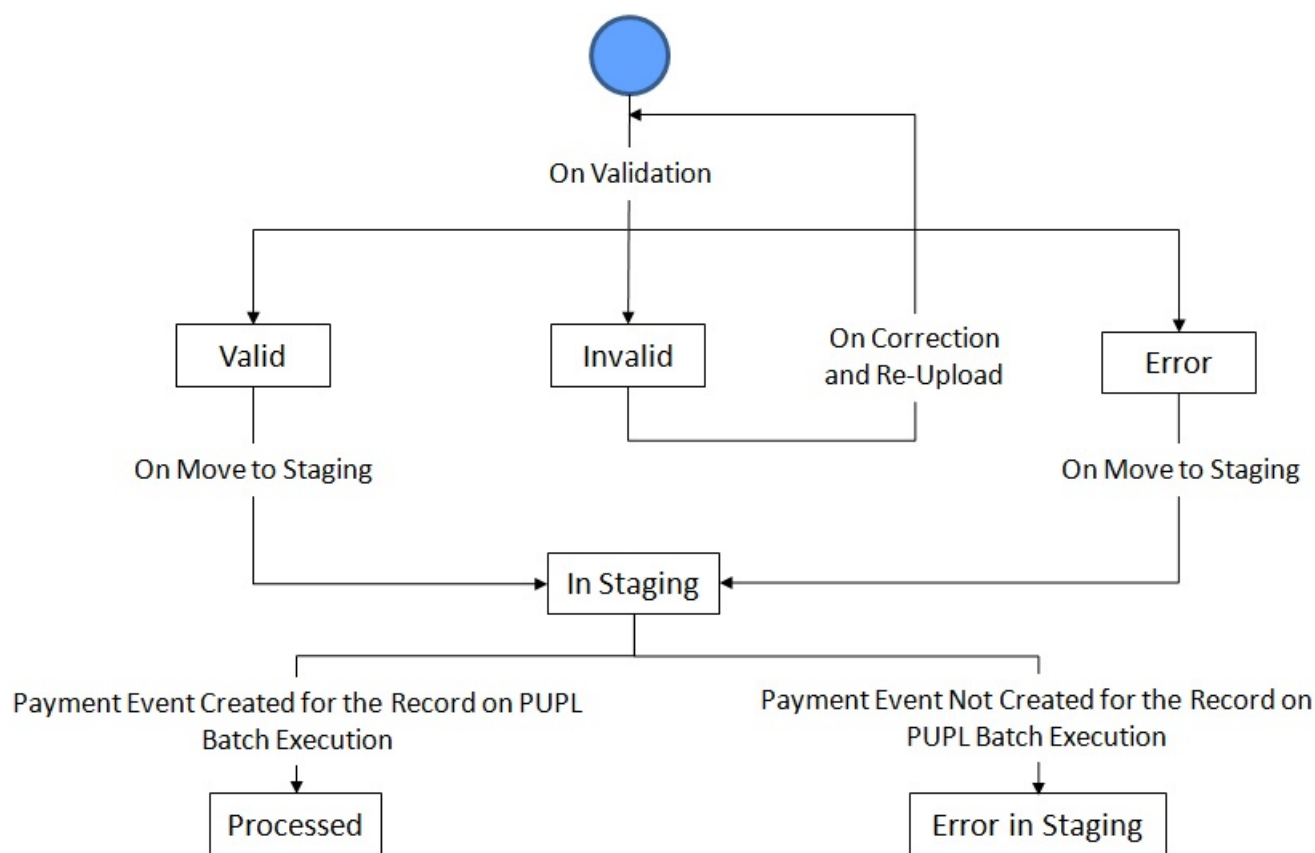

The following table lists the scenarios when a payment record is set to **Invalid** or **Error** status:

Scenario	Payment Record Status
The system could not find the payee account ID for a given account identifier type and account identifier combination when the payee account ID is not specified in the payment record.	Invalid
The payee account ID specified in the payment record does not exist in the system.	Invalid
The payee account ID, account identifier type, or account identifier are not specified in the payment record.	Invalid
The match type is not specified in the payment record.	Invalid
The match type specified in the payment record does not exist in the system.	Error
The match value is not specified in the payment record.	Invalid
The currency code does not exist in the system.	Invalid
The tender amount is either zero or not specified in the payment record.	Invalid
The payment amount is either zero or not specified in the payment record.	Invalid
The bank account is not specified in the payment record.	Invalid
The payment type (i.e. tender type) does not exist in the system.	Invalid

Scenario	Payment Record Status
The payment type is not specified in the payment record.	Invalid
The tender ID is not specified in the payment record.	Invalid
The date received is not specified in the payment record.	Invalid
The payor account ID specified in the payment record does not exist in the system.	Invalid
The characteristic type specified in the payment record does not exist in the system.	Invalid
If a characteristic type is specified, but the characteristic value is not specified in the payment record.	Invalid
If a characteristic value is specified, but the characteristic type is not specified in the payment record.	Invalid
The characteristic value does not match any predefined value when the characteristic value type is set to <b>Predefined Value</b> .	Invalid

**Note:** The system does the match type and match value related validations only when the **Is Match Type Validation Required (Y/N)** parameter is set to **Y** in the validation algorithm.

## Error Messages

The following table lists the errors that may occur during the payment upload process. It also indicates how you can resolve these errors.

Message Number	Error Message	Message Category	Possible Issues
80110	File cannot be reuploaded as some records have already been processed.	11111	The possible issues could be: <ul style="list-style-type: none"> <li>You are trying to replace an existing file whose payment records are already moved to the staging area and/or for which payment events are already created.</li> </ul>
1463	This file already exists in the system. Please check.	17000	The possible issues could be: <ul style="list-style-type: none"> <li>You are trying to upload a file which is already uploaded in the system without selecting the <b>Replace Existing File</b> check box.</li> </ul>
1465	Please upload a file in the CSV format.	17000	The possible issues could be: <ul style="list-style-type: none"> <li>You are trying to upload a file which is not in the CSV format.</li> </ul>
80113	Duplicate Header for column %1 in file.	11111	The possible issues could be: <ul style="list-style-type: none"> <li>The file has two or more columns with the same header.</li> </ul>

Message Number	Error Message	Message Category	Possible Issues																																				
80111	Length of value %1 too long for Field %2. Maximum length: %3 Found %4.	11111	<p>The possible issues could be:</p> <ul style="list-style-type: none"> <li>The length of value specified in the column exceeds the maximum field length. The following table lists the maximum length of each field:</li> </ul> <table border="1" data-bbox="1089 436 1461 1659"> <thead> <tr> <th data-bbox="1089 436 1317 520">Column Name</th> <th data-bbox="1317 436 1461 520">Maximum Length</th> </tr> </thead> <tbody> <tr> <td data-bbox="1089 520 1317 569">Account ID</td> <td data-bbox="1317 520 1461 569">10</td> </tr> <tr> <td data-bbox="1089 569 1317 617">Match Type</td> <td data-bbox="1317 569 1461 617">8</td> </tr> <tr> <td data-bbox="1089 617 1317 665">Match Value</td> <td data-bbox="1317 617 1461 665">30</td> </tr> <tr> <td data-bbox="1089 665 1317 714">Tender ID</td> <td data-bbox="1317 665 1461 714">12</td> </tr> <tr> <td data-bbox="1089 714 1317 762">Tender Amount</td> <td data-bbox="1317 714 1461 762">15</td> </tr> <tr> <td data-bbox="1089 762 1317 810">Payment Amount</td> <td data-bbox="1317 762 1461 810">15</td> </tr> <tr> <td data-bbox="1089 810 1317 858">Date Received</td> <td data-bbox="1317 810 1461 858">10</td> </tr> <tr> <td data-bbox="1089 858 1317 907">Bank Account</td> <td data-bbox="1317 858 1461 907">30</td> </tr> <tr> <td data-bbox="1089 907 1317 955">Payment Type</td> <td data-bbox="1317 907 1461 955">4</td> </tr> <tr> <td data-bbox="1089 955 1317 1003">Check Number</td> <td data-bbox="1317 955 1461 1003">10</td> </tr> <tr> <td data-bbox="1089 1003 1317 1052">Currency</td> <td data-bbox="1317 1003 1461 1052">3</td> </tr> <tr> <td data-bbox="1089 1052 1317 1100">Account ID Type</td> <td data-bbox="1317 1052 1461 1100">8</td> </tr> <tr> <td data-bbox="1089 1100 1317 1192">Account Identifier</td> <td data-bbox="1317 1100 1461 1192">30</td> </tr> <tr> <td data-bbox="1089 1192 1317 1381">Payment Char Type1, Payment Char Type2, ....., Payment Char Type5</td> <td data-bbox="1317 1192 1461 1381">8</td> </tr> <tr> <td data-bbox="1089 1381 1317 1560">Payment Char Value1, Payment Char Value2, ....., Payment Char Value5</td> <td data-bbox="1317 1381 1461 1560">254</td> </tr> <tr> <td data-bbox="1089 1560 1317 1608">MICR ID</td> <td data-bbox="1317 1560 1461 1608">30</td> </tr> <tr> <td data-bbox="1089 1608 1317 1659">Payor ID</td> <td data-bbox="1317 1608 1461 1659">10</td> </tr> </tbody> </table>	Column Name	Maximum Length	Account ID	10	Match Type	8	Match Value	30	Tender ID	12	Tender Amount	15	Payment Amount	15	Date Received	10	Bank Account	30	Payment Type	4	Check Number	10	Currency	3	Account ID Type	8	Account Identifier	30	Payment Char Type1, Payment Char Type2, ....., Payment Char Type5	8	Payment Char Value1, Payment Char Value2, ....., Payment Char Value5	254	MICR ID	30	Payor ID	10
Column Name	Maximum Length																																						
Account ID	10																																						
Match Type	8																																						
Match Value	30																																						
Tender ID	12																																						
Tender Amount	15																																						
Payment Amount	15																																						
Date Received	10																																						
Bank Account	30																																						
Payment Type	4																																						
Check Number	10																																						
Currency	3																																						
Account ID Type	8																																						
Account Identifier	30																																						
Payment Char Type1, Payment Char Type2, ....., Payment Char Type5	8																																						
Payment Char Value1, Payment Char Value2, ....., Payment Char Value5	254																																						
MICR ID	30																																						
Payor ID	10																																						

Message Number	Error Message	Message Category	Possible Issues
80085	Invalid value for column: %1.	11111	<p>The possible issues could be:</p> <ul style="list-style-type: none"> <li>• The payee account ID specified in the payment record does not exist in the system.</li> <li>• The match type specified in the payment record does not exist in the system.</li> <li>• The currency code does not exist in the system.</li> <li>• The account identifier type specified in the payment record does not exist in the system.</li> <li>• The tender amount is either zero or not specified in the payment record.</li> <li>• The payment amount is either zero or not specified in the payment record.</li> <li>• The bank account is not specified in the payment record.</li> <li>• The payment type (i.e. tender type) does not exist in the system.</li> <li>• The tender ID is not specified in the payment record.</li> <li>• The date received is not specified in the payment record.</li> <li>• The characteristic type specified in the payment record does not exist in the system.</li> <li>• The payor account ID specified in the payment record does not exist in the system.</li> </ul>
80100	Invalid Account Identifier and Account Identifier Type code combination.	11111	<p>The possible issues could be:</p> <ul style="list-style-type: none"> <li>• The system could not find the payee account ID for a given account identifier type and account identifier combination when the payee account ID is not specified in the payment record.</li> </ul>

Message Number	Error Message	Message Category	Possible Issues
80086	%1 has more decimal positions than currency code %2 supports (%3).	11111	The possible issues could be: <ul style="list-style-type: none"> <li>The precision specified for the tender amount exceeds the decimal places defined for the currency in the system.</li> <li>The precision specified for the payment amount exceeds the decimal places defined for the currency in the system.</li> </ul>
13601	Tender Source does not exist for External Source ID (%1)	11	The possible issues could be: <ul style="list-style-type: none"> <li>The tender source does not exist for the external source ID in the system.</li> </ul>
13603	Deposit control (%1/%2) Deposit Amount is not equal to sum of Tender Amounts	11	The possible issues could be: <ul style="list-style-type: none"> <li>The sum of tender control staging amount does not match the deposit control staging amount.</li> </ul>
13604	Deposit Control (%1/%2) Tender count does not equal the number of Tender controls	11	The possible issues could be: <ul style="list-style-type: none"> <li>The number of tender control staging records does not match the total tender controls specified in the deposit control staging record.</li> </ul>
13605	Tender control (%1/%2/%3) Total Tender Amount not equal to sum of Tender Amounts	11	The possible issues could be: <ul style="list-style-type: none"> <li>The sum of payment tender staging amount does not match the total tender amount specified in tender control staging record.</li> </ul>
13606	Tender control (%1/%2/%3) tender count does not equal the number of Tenders	11	The possible issues could be: <ul style="list-style-type: none"> <li>The number of payment tender staging records does not match the total number of tenders specified in the tender control staging record.</li> </ul>
13607	Suspense Contract does not exist for External Source ID (%1)	11	The possible issues could be: <ul style="list-style-type: none"> <li>The suspense contract is not defined for the tender source.</li> </ul>
13608	Many Tender Sources found for External Source ID (%1)	11	The possible issues could be: <ul style="list-style-type: none"> <li>There are multiple tender sources in the system with the same external source ID.</li> </ul>



Message Number	Error Message	Message Category	Possible Issues
13701	Pay Tender (%1/%2/%3/%4) Amount not equal to sum of Pay Amounts	11	The possible issues could be: <ul style="list-style-type: none"> <li>The sum of payment staging amount does not match the total amount specified in payment tender staging record.</li> </ul>
13705	Payment (%1/%2/%3/%4) Person ID (%5) exists on multiple accounts.	11	The possible issues could be: <ul style="list-style-type: none"> <li>There are multiple payment records having contracts with the same old account ID but their payee account ID is different.</li> </ul>
80194	File has no records to upload	11111	The possible issues could be: <ul style="list-style-type: none"> <li>You are trying to upload a file without any payment records.</li> </ul>
80195	Incorrect header: %1	11111	The possible issues could be: <ul style="list-style-type: none"> <li>One or more column names in the payment data file are incorrect.</li> </ul>
80196	Maximum file name size allowed is 60 characters	11111	The possible issues could be: <ul style="list-style-type: none"> <li>The file name contains more than 60 characters.</li> </ul>
80199	Missing value for column %1	11111	The possible issues could be: <ul style="list-style-type: none"> <li>The match type is not specified in the payment record.</li> <li>The match value is not specified in the payment record.</li> <li>The payment type is not specified in the payment record.</li> </ul>

## Payment Upload

---

The **Payment Upload** screen allows you to search for a payment data file using various search criteria. Through this screen, you can:

- Upload a payment data file
- Cancel a payment data file
- View the records uploaded through a payment data file
- View the log of a payment data file
- Move the payment records to the staging area
- Edit a payment staging record
- Replace an existing payment data file
- View the reasons why the payment record is in the **Error** or **Invalid** status

This screen consists of the following zones:

- [Search Payment Data File](#) on page 1050
- [Payment Data Records](#) on page 1052
- [Payment Data File Log](#) on page 1053

## Search Payment Data File

The **Search Payment Data File** zone allows you to search for a payment data file which is uploaded and/or processed in the system. This zone contains the following two sections:



- **Search Criteria** — the **Search Criteria** section contains the following fields:

Field Name	Field Description	Mandatory (Yes or No)
File Name	Used to search a particular payment data file.	No
User ID	Used to search payment data files which are uploaded by a particular user.	No
Upload From Date	Used to search payment data files which are uploaded from a particular date onwards.  <b>Note:</b> By default, the date is set to the current date minus 7 days. You can change the date, if required.	No
To	Used to search payment data files which are uploaded till a particular date.  <b>Note:</b> By default, the date is set to the current date. You can change the date, if required.	No
File Type	Used to search payment data files which are uploaded using a particular file type.	No
File Status	Used to search payment data files with a particular status. The valid values are: <ul style="list-style-type: none"> <li>• Cancelled</li> <li>• In Staging</li> <li>• Partially Processed</li> <li>• Pending</li> <li>• Processed</li> <li>• Validated</li> </ul>	No

**Note:** You must specify at least one search criterion while searching for a payment data file.

- **Search Results** — On clicking the **Search** button, the search results appear based on the specified search criteria. The **Search Results** section contains the following columns:

Column Name	Column Description
File Name	Displays the name of the payment data file.
File Type	Indicates the type of the payment data file.
Upload Date	Displays the date and time when the payment data file was uploaded in the system.

Column Name	Column Description
Status	Indicates the status of the payment data file. The valid values are: <ul style="list-style-type: none"> <li>Cancelled</li> <li>In Staging</li> <li>Partially Processed</li> <li>Pending</li> <li>Processed</li> <li>Validated</li> </ul>
Total	Displays the total number of records that are uploaded through the payment data file.
Valid	Displays the number of records which are successfully validated in the system.
Invalid	Displays the number of records which could not pass through the validation process in the system.
Error	Displays the number of records where the data is incorrect.
In Staging	Displays the number of records which are copied from the pre-staging to staging area.
Processed	Displays the number of records for which payment events are created.
Staging Error	Displays the number of records for which payment events could not be created.
Cancel	On clicking the <b>Cancel</b> (  ) icon, you can cancel the payment data file. <div style="border: 1px solid black; padding: 5px; margin-top: 10px;"> <p><b>Note:</b> The <b>Cancel</b> icon appears only when the status of the payment data file is <b>Validated</b>. In other words, you cannot cancel a payment data file when its records are moved to the staging area or when the payment events are created for the payment data file.</p> </div>
Move to Staging	On clicking the <b>Move to Staging</b> (  ) icon, you can move the valid and error records of the payment data file to the staging area. <div style="border: 1px solid black; padding: 5px; margin-top: 10px;"> <p><b>Note:</b> The <b>Move to Staging</b> icon appears only when:</p> <ul style="list-style-type: none"> <li>The status of the payment data file is <b>Validated</b>.</li> <li>There are no invalid records in the payment data file.</li> <li>The <b>Disable Move to Staging</b> check box is not selected in the respective file type.</li> </ul> </div>

You can upload a payment data file by clicking the **Upload** link in the upper right corner of this zone. On clicking the **Broadcast** () icon corresponding to the payment data file, the **Payment Data Records** and **Payment Data File Log** zones appear.

#### Related Topics

For more information on...	See...
<b>Payment Upload</b> screen	<a href="#">Payment Upload</a> on page 1049

For more information on...	See...
How to upload a payment data file	<a href="#">Uploading a Payment Data File</a> on page 1054
How to search for a payment data file	<a href="#">Searching for a Payment Data File</a> on page 1054
How to cancel a payment data file	<a href="#">Cancelling a Payment Data File</a> on page 1057
How to replace an existing payment data file	<a href="#">Replacing an Existing File</a> on page 1056
How to move the payment records to the staging area	<a href="#">Moving the Payment Records to the Staging Area</a> on page 1057
How to edit a payment staging record	<a href="#">Editing a Payment Staging Record</a> on page 1058
How to view the records of a payment data file	<a href="#">Viewing the Records of a Payment Data File</a> on page 1059
How to view the log of a payment data file	<a href="#">Viewing the Log of a Payment Data File</a> on page 1059

## Payment Data Records

The **Payment Data Records** zone lists the records of the payment data file. This zone contains the following columns:

Column Name	Column Description
Payor Account ID	Indicates the account which made the payment.
Payee Account ID	Indicates the account for which the payment was made.
Match Type	Indicates the match type using which the payment must be matched.
Match Value	Indicates the entity (such as bill, contract, and so on) against which the payment must be matched.
Pay Tender ID	Displays the payment tender ID.
Tender Amount	Displays the tender amount.
Payment Amount	Displays the amount paid through the tender.
Currency	Indicates the currency in which the payment was made.
Date Received	Displays the date when the payment was made.
Bank Account	Displays the bank account from which the payment was made.
Tender Type	Indicates the type of tender through which the payment was made.
Check Number	Displays the check number if the payment was made through check.
MICR ID	Displays the MICR code.
Status	Indicates the status of the payment record. The valid values are: <ul style="list-style-type: none"> <li>• Valid</li> <li>• Invalid</li> <li>• Error</li> <li>• In Staging</li> <li>• Processed</li> <li>• Error in Staging</li> </ul>

Column Name	Column Description
Payment Information Event	<p>Displays information about the payment event which is created for the payment record.</p> <p><b>Note:</b></p> <p>It has a link. On clicking the link, the <b>Payment Event</b> screen appears with the details of the respective payment event.</p> <p>The data appears in this column only when the status of the payment record is <b>Processed</b>.</p>
Payment Staging Record	<p>On clicking the <b>Edit</b> (✎) icon, the <b>Payment Upload Staging</b> screen appears where you can edit the details of the payment staging record.</p> <p><b>Note:</b> The <b>Edit</b> icon appears only when the status of the payment record is <b>In Staging</b>.</p>
Error Message	<p>On clicking the <b>View</b> (👁) icon, the <b>Error Messages</b> window appears where you can view the reasons why the status of the payment record is <b>Invalid</b> or <b>Error</b>.</p> <p><b>Note:</b> The <b>View</b> icon appears only when the status of the payment record is <b>Error</b> or <b>Invalid</b>.</p>

**Note:** Pagination is used to display limited number of records in the **Payment Data Records** zone. By default, 20 records are displayed in this zone. You can use the navigation links, such as **Previous** and **Next** to navigate between pages.

By default, the **Payment Data Records** zone does not appear in the **Payment Upload** screen. It appears only when you click the **Broadcast** (📡) icon corresponding to the payment data file in the **Search Payment Data File** zone.

#### **Related Topics**

For more information on...	See...
How to view the records of a payment data file	<a href="#">Viewing the Records of a Payment Data File</a> on page 1059
How to view the reasons why the status of the payment record is <b>Invalid</b> or <b>Error</b>	<a href="#">Viewing the Error Messages</a> on page 1060

## Payment Data File Log

The **Payment Data File Log** zone lists the complete trail of actions performed on the payment data file. This zone contains the following columns:

Column Name	Column Description
Date/Time	Displays the date and time when the action was performed on the payment data file.
Log Details	Displays the details about the action performed on the payment data file.
User	Indicates the user who has performed the action on the payment data file.

By default, the **Payment Data File Log** zone does not appear in the **Payment Upload** screen. It appears only when you click the **Broadcast** (📡) icon corresponding to the payment data file in the **Search Payment Data File** zone.

#### **Related Topics**

For more information on...	See...
How to view the log of a payment data file	<a href="#">Viewing the Log of a Payment Data File</a> on page 1059

## Searching for a Payment Data File

### Prerequisites

To search for a payment data file, you should have:

- File types defined in the application (where the feed type is set to Payment Upload Data)

### Procedure

To search for a payment data file:

1. Click the **Menu** link in the **Application** toolbar.  
A list appears.
2. From the **Main** menu, select **Financial** and then click **Payment Upload**.  
The **Payment Upload** screen appears.
3. Enter the search criteria in the **Search Payment Data File** zone.

**Note:** ORMB search engine supports wildcard search, where you can substitute the percentage (%) symbol as a stand in for any word or letter in a search criteria. You can use the ‘%’ wildcard character in all input fields except the date and ID fields. The ‘%’ wildcard character is suffixed automatically at the end of the partial search criteria. Therefore, you may or may not specify the wildcard character at the end of the partial search criteria. However, you have to prefix the wildcard character manually wherever required.

4. Click **Search**.

A list of payment data files that meet the search criteria appears in the **Search Results** section.

### Related Topics

For more information on...	See...
<b>Payment Upload</b> screen	<a href="#">Payment Upload</a> on page 1049
<b>Search Payment Data File</b> zone	<a href="#">Search Payment Data File</a> on page 1050

## Uploading a Payment Data File

### Prerequisites

To upload a payment data file, you should have:

- File types defined in the application (where the feed type is set to Payment Upload Data)
- Payment data in the required CSV file format

### Procedure

To upload a payment data file:

1. Click the **Menu** link in the **Application** toolbar.  
A list appears.
2. From the **Main** menu, select **Financial** and then click **Payment Upload**.  
The **Payment Upload** screen appears.

- Click the **Upload** link in the upper right corner of the **Search Payment Data File** zone.

The **Upload Payment Data File** screen appears. It contains the following fields:

Field Name	Field Description	Mandatory (Yes or No)
File Type	Used to indicate the type of payment data file.  <b>Note:</b> The list includes only those file types where the feed type is set to <b>Payment Upload Data</b> .	Yes
File Name	Used to specify the name and path of the payment data file that you want to upload.  <b>Note:</b> You can also click the <b>Browse</b> button corresponding to this field to browse to the location where the payment data file is available in the system.	Yes
Replace Existing File	Used to indicate whether you want to replace any existing file in the system. You must select this check box when you want to upload the same file once again.	No

- Select the type of payment data file from the **File Type** list.
- Click the **Browse** button corresponding to the **File Name** field.

The **Choose File to Upload** dialog box appears.

- Browse to the location where the payment data file that you want to upload is available.
- Click **Open**.

The payment data file name and path appears in the **File Name** field.

- Click **Upload**.

A message appears indicating that the payment data file is uploaded successfully. If an error occurs while parsing, the payment data file is not uploaded in the system.

**Note:** If a payment data file contains more than 1000 payment records, the system will not allow you to upload the payment data file in the system. Therefore, ensure that a payment data file contains less than 1000 payment records.

- Click **OK** in the message box.

On uploading the payment data file, the payment records are copied to the pre-staging area and the status of the payment data file is set to **Pending**. The validation process starts immediately after the payment data file is uploaded in the system. If a payment record is successfully validated, the status of the payment record is set to **Valid**. If a payment record contains incorrect or missing data, the status of the payment record is set to either **Invalid** or **Error** depending on the scenario. For more information about the scenarios when a payment record is set to the **Invalid** or **Error** status, see [Payment Record Status Transition](#) on page 1043.

Once the validation process is completed, the status of the payment data file is changed to **Validated**. If a payment data file contains an invalid record, you need to correct or add missing data in the CSV file and then upload the file once again. Unless, a payment data file has no invalid records, you cannot move any record of the payment data file to the staging area.

### Related Topics

For more information on...	See...
<b>Payment Upload</b> screen	<a href="#">Payment Upload</a> on page 1049

<b>For more information on...</b>	<b>See...</b>
<b>Search Payment Data File</b> zone	<a href="#">Search Payment Data File</a> on page 1050

## Replacing an Existing File

### Prerequisites

To replace an existing payment data file, you should have:

- File types defined in the application (where the feed type is set to Payment Upload Data)
- Payment data in the required CSV file format

### Procedure

To replace an existing payment data file:

1. Click the **Menu** link in the **Application** toolbar.  
A list appears.
2. From the **Main** menu, select **Financial** and then click **Payment Upload**.  
The **Payment Upload** screen appears.
3. Click the **Upload** link in the upper right corner of the **Search Payment Data File** zone.  
The **Upload Payment Data File** screen appears.
4. Select the type of payment data file from the **File Type** list.
5. Click the **Browse** button corresponding to the **File Name** field.  
The **Choose File to Upload** dialog box appears.
6. Browse to the location where the payment data file that you want to upload is available.
7. Click **Open**.  
The payment data file name and path appears in the **File Name** field.
8. Select the **Replace Existing File** check box.

**Note:** You can replace an existing file only when the payment data file is in the **Validated** status. In other words, you cannot replace a file whose payment records are already moved to the staging area and/or for which payment events are already created.

9. Click **Upload**.

A message appears indicating that the payment data file is uploaded successfully. If an error occurs while parsing, the payment data file is not uploaded in the system.

10. Click **OK** in the message box.

Once the payment data file is successfully uploaded, the status of the payment data file is set to **Pending**. The validation process starts immediately after the payment data file is uploaded in the system. If a payment record is successfully validated, the status of the payment record is changed to **Valid**. If a payment record contains incorrect or missing data, the status of the payment record is changed to either **Invalid** or **Error** depending on the scenario. For more information about the scenarios when a payment record is set to the **Invalid** or **Error** status, see [Payment Record Status Transition](#) on page 1043. You can view the details of the uploaded payment data file and its records in the **Payment Upload** screen.

Once the validation process is completed, the payment records are copied to the pre-staging area and the status of the payment data file is changed to **Validated**. If a payment data file contains an invalid record, you need to



correct or add missing data in the CSV file and then upload the file once again. Unless, a payment data file has no invalid records, you cannot move any record of the payment data file to the staging area.

### Related Topics

For more information on...	See...
Payment Upload screen	<a href="#">Payment Upload</a> on page 1049
Search Payment Data File zone	<a href="#">Search Payment Data File</a> on page 1050

## Cancelling a Payment Data File

There might be situations when incorrect payment data file is uploaded in the system. In such case, the system provides you with an ability to cancel the file. However, note that you can cancel a payment data file only when it is in the **Validated** status. In other words, you cannot cancel a payment data file when its records are moved to the staging area or when the payment events are created for the payment data file.

### Procedure

To cancel a payment data file:

1. Search for the payment data file in the **Payment Upload** screen.
2. In the **Search Results** section, click the **Cancel** () icon in the **Cancel** column corresponding to the payment data file that you want to cancel.

A message appears confirming whether you want to cancel the payment data file.

**Note:** The **Cancel** icon appears only when the status of the payment data file is **Validated**.

3. Click **OK**.

The status of the payment data file is changed to **Cancelled**.

### Related Topics

For more information on...	See...
How to search for a payment data file	<a href="#">Searching for a Payment Data File</a> on page 1054

## Moving the Payment Records to the Staging Area

### Procedure

To move the payment records to the staging area:

1. Search for the payment data file in the **Payment Upload** screen.
2. In the **Search Results** section, click the **Move to Staging** () icon in the **Move to Staging** column corresponding to the payment data file whose records you want to move to the staging area.

A message appears confirming whether you want to move all payment records to the payment upload staging area.

**Note:**

The **Move to Staging** icon appears only when:

- The status of the payment data file is **Validated**.
- There are no invalid records in the payment data file.
- The **Disable Move to Staging** check box is not selected in the respective file type.

The system allows you to move only valid and error records of a payment data file to the staging area. If a payment data file contains an invalid record, you cannot move any record of the payment data file to the staging area.

3. Click **OK** in the message box.

A message appears indicating that the payment records are successfully copied from the pre-staging to staging area.

4. Click **OK** in the message box.

The status of the payment data file is changed to **In Staging**. In addition, the status of the payment records in the pre-staging area is changed to **In Staging** and the status of the deposit control, tender control, and payment tender staging records is set to **Pending**.

**Related Topics**

For more information on...	See...
How to search for a payment data file	<a href="#">Searching for a Payment Data File</a> on page 1054

**Editing a Payment Staging Record**

You can edit a payment record only when it is moved from the pre-staging to staging area. On editing a payment record in the staging area, the system does not reflect the changes in the pre-staging area. It only reflects the changes in the staging area.

**Procedure**

To edit a payment staging record:

1. Search for the payment data file in the **Payment Upload** screen.
2. In the **Search Results** section, click the **Broadcast**  icon corresponding to the payment data file whose staging records you want to edit.

The **Payment Data Records** and **Payment Data File Log** zones appear.

3. In the **Payment Data Records** zone, click the **Edit**  icon in the **Payment Staging Record** column corresponding to the payment record whose details you want to edit in the staging area.

The **Payment Upload Staging** screen appears. It contains the following tabs:

- **Tender Details** — Enables you to view and edit the tender control staging details.
- **Payment Advice** — Enables you to view and edit the payment staging details.
- **Payment Characteristics** — Enables you to view and edit the payment characteristic staging details.

**Note:** The **Edit** icon appears only when the status of the payment record is **In Staging**.

4. Modify the required details.
5. Click the **Save** link in the **Application** toolbar.

The changes made to the payment staging record are saved.

### Related Topics

For more information on...	See...
How to search for a payment data file	<a href="#">Searching for a Payment Data File</a> on page 1054

## Viewing the Records of a Payment Data File

### Procedure

To view the records of a payment data file:

1. Search for the payment data file in the **Payment Upload** screen.
2. In the **Search Results** section, click the **Broadcast**  icon corresponding to the payment data file whose records you want to view.

The **Payment Data Records** and **Payment Data File Log** zones appear.

3. View the details of the payment records, which are uploaded through the payment data file, in the **Payment Data Records** zone.

### Related Topics

For more information on...	See...
How to search for a payment data file	<a href="#">Searching for a Payment Data File</a> on page 1054
<b>Payment Data Records</b> zone	<a href="#">Payment Data Records</a> on page 1052

## Viewing the Log of a Payment Data File

### Procedure

To view the log of a payment data file:

1. Search for the payment data file in the **Payment Upload** screen.
2. In the **Search Results** section, click the **Broadcast**  icon corresponding to the payment data file whose log you want to view.

The **Payment Data Records** and **Payment Data File Log** zones appear.

3. View the actions performed on the payment data file in the **Payment Data File Log** zone.

### Related Topics

For more information on...	See...
How to search for a payment data file	<a href="#">Searching for a Payment Data File</a> on page 1054
<b>Payment Data File Log</b> zone	<a href="#">Payment Data File Log</a> on page 1053

## Viewing the Error Messages

The system allows you to view the reasons why the payment record in a payment data file is in the **Error** or **Invalid** status.

### Procedure

To view the error messages:

1. Search for the payment data file in the **Payment Upload** screen.
2. In the **Search Results** section, click the **Broadcast**  icon corresponding to the payment data file whose payment records are in the **Error** or **Invalid** status.

The **Payment Data Records** and **Payment Data File Log** zones appear.

3. In the **Payment Data Records** zone, click the **View**  icon in the **Error Message** column corresponding to the payment record which is in the **Error** or **Invalid** status.

The **Error Messages** window appears. It lists the reasons why the payment record is in the **Error** or **Invalid** status. If the payment record is in the **Invalid** status, you need to correct or add missing data in the CSV file and then upload the file once again. Unless, a payment data file has no invalid records, you cannot move any record of the payment data file to the staging area.

**Note:** The **View** icon appears only when the status of the payment record is **Error** or **Invalid**.

4. View the reasons in the **Error Messages** window.
5. Click **OK**.

### Related Topics

For more information on...	See...
How to search for a payment data file	<a href="#">Searching for a Payment Data File</a> on page 1054
<b>Payment Data Records</b> zone	<a href="#">Payment Data Records</a> on page 1052

---

# Chapter 13

---

## Freeze Payments on Notification

---

### Topics:

- [Freeze Payments on Notification Process](#)
- [Prerequisites](#)
- [Automatic Payment or Refund Clearing Staging Record Status Transition](#)
- [EDI 824 File Format](#)
- [Sample EDI 824 File Format](#)
- [Automatic Payment and Refund Upload Reason](#)
- [Automatic Payment and Refund Clearing Staging](#)

Oracle Revenue Management and Billing facilitates you to create automatic payments and refunds when the automatic payment option is enabled for an account. A clearing record is created for each automatic payment and refund in the system. You can then send the automatic payment and refund clearing records to the auto clearing house for verification. The system provides the mechanism to extract the automatic payment clearing records in a flat file. You can then send the flat file to the auto clearing house for verification. However, the implementation team will have to write the custom logic to extract the automatic refund clearing records in a file which you can then send to the auto clearing house for verification.

Once the auto clearing house reviews the automatic payment clearing records, the system allows you to upload review comments received in the EDI 824 file format. On uploading an EDI 824 file, an automatic payment clearing staging record is created for each valid automatic payment clearing ID. The data received from the auto clearing house is stored in the following staging tables:

- CI\_APAY\_STAGE\_UP
- CI\_APAY\_STAGE\_UP\_REM
- CI\_APAY\_STGUP\_CHAR

The implementation team will have to write the custom logic to upload review comments for automatic refund clearing records in the above mentioned staging tables. The review comments for automatic payment clearing records can be received in the form of reason (i.e. upload reason) and error codes (i.e. payment cancelation reason or NOC reason) which will help you to determine whether the automatic payment must be frozen or cancelled in the system. Similarly, the review comments for automatic refund clearing records can be received in the form of reason (i.e. upload reason) and error codes (i.e. void status reason) which will help you to determine whether the refund request must be voided and refund adjustments must be cancelled in the system.

Once the review comments are received from the auto clearing house, you can do the following:

- Freeze or cancel the automatic payments
- Void the refund requests and cancel the refund adjustments

For more detailed information about the freeze payments on notification process, see [Freeze Payments on Notification Process](#) on page 1063.

The system allows you to define upload reasons, payment cancelation reasons, NOC reasons, and void status reasons. The system also allows you to edit and delete the automatic payment and refund clearing staging records through the user interface. However, you can edit an automatic payment or refund clearing staging record only when it is in the **Pending** or **Error** status, and you can

delete an automatic payment or refund clearing staging record only when it is in the **Pending** status. During the freeze payments on notification process, the automatic payment and refund clearing staging records go through various statuses in its lifecycle. For more information about the statuses, see [Automatic Payment or Refund Clearing Staging Record Status Transition](#) on page 1067.

For more information on how to setup the freeze payments on notification process, see [Prerequisites](#) on page 1066.

## Freeze Payments on Notification Process

---

The Freeze Payments on Notification process includes the following sub-processes:

1. [Creating Automatic Payments and Refunds](#) on page 1063
2. [Generating a Flat File](#) on page 1063
3. [Uploading Response from Auto Clearing House \(ACH\)](#) on page 1063
4. [Freezing or Canceling Automatic Payments](#) on page 1064
5. [Voiding Refund Requests and Canceling Refund Adjustments](#) on page 1065
6. [Generating To Do Entries](#) on page 1065
7. [Creating Tender Controls](#) on page 1065

Note that during the freeze payments on notification process, you need to execute the following batches in the specified order:

1. Create Automatic Payments and Refunds (APAYCRET)
2. Activate Automatic Payments (ACTVTAPY)
3. Extract Automatic Payments (APAYACH)
4. Upload Response from Auto Clearing House (C1-APACK)
5. Freeze or Cancel Automatic Payments (APAYRA)
6. Cancel Automatic Refunds (AREFRA)
7. To Do Creation for Automatic Payment Exception Records (APAYUPTD)
8. Create Tender Controls for Automatic Payments (BALAPY)

For more information about these batches, see *Oracle Revenue Management and Billing Batch Guide*.

### Creating Automatic Payments and Refunds

If you have configured the automatic payment option for an account, the system calculates the automatic payment amount and extract date during the bill completion and stamps these details against the bill in the **CI\_BILL\_ACH** table. The **Create Automatic Payments and Refunds (APAYCRET)** batch allows you to create automatic payment and refund request depending on whether the automatic payment amount is in debit or credit. It also creates a clearing record for each automatic payment and refund in the **CI\_APAY\_CLR\_STG** and **CI\_ADJ\_CLR\_STG** tables, respectively. For more information about the batch, see *Oracle Revenue Management and Billing Batch Guide*.

### Generating a Flat File

Unless you activate a clearing record, you cannot extract the clearing record in a flat file. The **Activate Automatic Payments (ACTVTAPY)** batch allows you to activate a clearing record. It stamps the **APAYACH** batch control and incremental batch run number on the clearing record.

Once the clearing records are activated, you can extract the clearing records in a flat file. The **Extract Automatic Payments (APAYACH)** batch allows you to extract the clearing records with the latest batch run number in a flat file. The flat file is then sent to the auto clearing house for review. For more information about these batches, see *Oracle Revenue Management and Billing Batch Guide*.

**Note:** At present, you cannot activate and extract the automatic refund clearing records using the **Activate Automatic Payments (ACTVTAPY)** and **Extract Automatic Payments (APAYACH)** batches, respectively. The implementation team will have to write the custom logic to activate and extract automatic refund clearing records in a flat file.

### Uploading Response from Auto Clearing House (ACH)

Once the auto clearing house reviews the automatic payment clearing records, the review comments can be shared in the EDI 824 file format. An EDI 824 file may contain the review comments for one or more automatic payment clearing records. You can upload these EDI 824 files and store the review comments in the staging area using the **Upload Response from Auto Clearing House (C1-APACK)** batch.

On uploading an EDI 824 file, the system checks whether the automatic payment clearing ID specified in each record exists in the system. If so, it creates an automatic payment clearing staging record for the automatic payment clearing

ID in the **CI\_APAY\_STAGE\_UP** table. If the acknowledgement code in the record is set to **TE** or **TR**, the system considers that the auto clearing house has rejected the automatic payment clearing record. The reason code (i.e. upload reason) specified in the **Reject Upload Reason** parameter of the **C1-APAY** algorithm is stored corresponding to the automatic payment clearing staging record in the **CI\_APAY\_STAGE\_UP\_REM** table. In addition, the error code (i.e. payment cancelation reason) is stored corresponding to the automatic payment clearing staging record in the **CI\_APAY\_STAGE\_UP\_REM** table.

However, if the acknowledgement code is blank or if the acknowledgement code is set to a value other than **TE** or **TR**, the system considers that the auto clearing house has accepted the automatic payment clearing record. The reason code (i.e. upload reason) specified in the **Success Upload Reason** parameter of the **C1-APAY** algorithm is stored corresponding to the automatic payment clearing staging record in the **CI\_APAY\_STAGE\_UP\_REM** table. In addition, the error code (i.e. NOC reason) is stored corresponding to the automatic payment clearing staging record in the **CI\_APAY\_STAGE\_UP\_REM** table. In this case, the record may contain more than one error code.

The status of the automatic payment clearing staging record is set to **Pending**. If the error code (i.e. payment cancelation reason or NOC reason) is invalid, the status of the automatic payment clearing staging record is set to **Error**. An exception is logged in the **CI\_APAY\_STGUP\_EXC** table. In addition, if the status of the NOC reason is **Inactive** in the system, the status of the automatic payment clearing staging record is set to **Error** and an exception is logged in the **CI\_APAY\_STGUP\_EXC** table.

The system sets the automatic payment distribution and freeze date (i.e. **APAY\_DIST\_FRZ\_DT**) for each automatic payment clearing record (for which automatic payment clearing staging record is added in the system) to the payment date (which is stored on the payment event). For more information about the batch, see *Oracle Revenue Management and Billing Batch Guide*.

**Note:** An additional table named **CI\_APAY\_STGUP\_CHAR** is available which the implementation team can use to store additional information about the automatic payment clearing staging record in the form of characteristics.

To ensure that the EDI 824 files are uploaded successfully, you need to set the following parameters in an algorithm which is created using the **C1-APAY** algorithm type:

- **Line Separator** - Used to indicate the character specified in the EDI 824 files to represent the end of line.
- **Field Separator** - Used to indicate the character specified in the EDI 824 files to represent the end of data record.
- **Reject Upload Reason** - Used to indicate the upload reason which you want to use when the auto clearing house has rejected the automatic payment clearing record.
- **Success Upload Reason** - Used to indicate the upload reason which you want to use when the auto clearing house has accepted the automatic payment clearing record with or without Notice to Change (NOC).

**Note:** You must specify an upload reason which is already defined in the system.

For more information about the EDI 824 file format, see [EDI 824 File Format](#) on page 1067.

## Freezing or Canceling Automatic Payments

Once the review comments are received in the form of reason and error codes for an automatic payment clearing record, you need to freeze or cancel the automatic payment based on the reason code. You can freeze or cancel automatic payments through the **Freeze or Cancel Automatic Payments (APAYRA)** batch.

On executing the **Freeze or Cancel Automatic Payments (APAYRA)** batch, the system checks whether the reason code (i.e. upload reason) and error code (i.e. payment cancelation reason or NOC reason) specified in the automatic payment clearing staging record exist in the system. This batch considers only those automatic payment clearing staging records which are in the **Pending** status and for which payment freeze date is specified in the automatic payment clearing record. If the reason code and error code exist in the system, the system executes the algorithms attached to the reason code in the specified sequence. If the type of reason code is **Cancel**, the attached algorithm cancels the automatic payment and payment event. If the type of reason code is **Success**, the attached algorithm freezes the automatic payment on the payment freeze date. However, if the type of reason code is **Success** and the error code is specified along with the reason code, the attached algorithm freezes the automatic payment on the payment freeze date, stores error codes (i.e.



NOC reasons) as payment tender characteristics and then creates a To Do entry to notify user about these NOC reasons. Finally, the status of the automatic payment clearing staging record is changed to **Complete**.

If the reason code and/or error code (i.e. upload reason, payment cancelation reason, or NOC reason) specified in the automatic payment clearing staging record does not exist in the system, the status of the automatic payment clearing staging record is changed to **Error**. In addition, if the status of the NOC reason is **Inactive** in the system, the status of the automatic payment clearing staging record is changed to **Error**. For more information about the batch, see *Oracle Revenue Management and Billing Batch Guide*.

## Voiding Refund Requests and Canceling Refund Adjustments

Once the auto clearing house reviews the automatic refund clearing records and shares the review comments, the implementation team will have to store the review comments in the following staging tables:

- **CI\_APAY\_STAGE\_UP** – Used to store the automatic payment or refund clearing staging record for an automatic payment or refund clearing record, respectively. The status of the automatic payment or refund clearing staging record must be set to **Pending**.
- **CI\_APAY\_STAGE\_UP\_REM** – Used to store the reason and error codes of each automatic payment or refund clearing staging record.
- **CI\_APAY\_STGUP\_CHAR** – Used to store additional information about the automatic payment or refund clearing staging record in the form of characteristics.

The review comments must be received in the form of reason (i.e. upload reason) and error codes (i.e. void status reason) for an automatic refund clearing record. On executing the **Cancel Automatic Refunds (AREFRA)** batch, it checks whether the reason and error codes specified in the automatic refund clearing staging record exist in the system. If the reason and error codes exist in the system, the system executes the algorithms attached to the reason code in the specified sequence. If the type of reason code is **Cancel**, the attached algorithm changes the status of the refund request to **Voided** and the corresponding refund adjustments are canceled. If the type of reason code is **Success**, no changes are made to the refund request and refund adjustments. Finally, the status of the automatic refund clearing staging record is changed to **Complete**.

If the reason code and/or error code (i.e. upload reason, void status reason) specified in the automatic refund clearing staging record does not exist in the system, the status of the automatic refund clearing staging record is changed to **Error**.

## Generating To Do Entries

If an exception occurs while executing the **Freeze or Cancel Automatic Payments (APAYRA)** batch, you can notify the user about such exception. The **To Do Creation for Automatic Payment Exception Records (APAYUPTD)** batch allows you to create a To Do using the APAYUPTD To Do type when an exception is logged for an automatic payment clearing staging record in the **CI\_APAY\_STGUP\_EXC** table. The system creates one To Do entry for all exceptions that have occurred for an automatic payment clearing staging record. For more information about these batches, see *Oracle Revenue Management and Billing Batch Guide*.

**Note:** At present, a To Do is not created when an exception is logged for an automatic refund clearing staging record in the **CI\_APAY\_STGUP\_EXC** table while executing the **Cancel Automatic Refunds (AREFRA)** batch.

## Creating Tender Controls

Once you freeze the automatic payments, you need to create tender and deposit controls. The **Create Tender Controls for Automatic Payments (BALAPY)** batch allows you to create tender and deposit controls for each automatic payment which is frozen, but not yet linked to any tender control. One tender control is created for the **APAYACH** batch control and batch run number combination. The payment tenders of these automatic payments are then linked to the tender control.

This batch also balances the open tender control records and changes the status of the tender and deposit controls, accordingly. For more information about the batch, see *Oracle Revenue Management and Billing Batch Guide*.

## Prerequisites

---

To setup the freeze payments on notification process, you need to do the following:

- Define the automatic payment instructions for the account for which you want to enable the automatic payment option.

**Note:** You can either define non-rule based effective dated automatic payment instructions in the **Auto Pay** tab of the **Account** screen or define rule based effective dated automatic payment instructions through the **Auto Pay Rule** screen.

- Set the **Autopay Creation Option** field to **Freeze Payment on Notification** in the **Billing** tab of the **Installation Options** screen.
- Create an automatic payment creation algorithm using the **APAY-CREATE** algorithm type and attach it to the **Automatic Payment Creation** system event in the **Algorithms** tab of the **Installation Options - Framework** screen.
- Create an automatic refund creation algorithm using the **C1-AREF-CRET** algorithm type and attach it to the **Automatic Adjustment Creation** system event in the **Algorithms** tab of the **Installation Options - Framework** screen.
- Create a date calculation algorithm using the **APAY-DTCALC** algorithm type and attach it to the **Autopay Date Calculation Alg** spot of the auto pay route type which is specified on the account's automatic payment instruction.
- Define the required upload reasons in the system.
- Define the required payment cancelation reasons in the system.
- Define values for the **APAY\_UPL\_NOC\_LOOKUP** lookup field.

**Note:** The **APAY\_UPL\_NOC\_LOOKUP** lookup field is used to define NOC reasons. The NOC reason specified in the automatic payment clearing staging record must exist in this lookup field and its status must be **Active**. Otherwise, the status of the automatic payment clearing staging record is changed to **Error**.

- Define voided status reasons for the **C1-RefundReq** business object.
- Create an automatic payment success algorithm using the **C1-APAY-SUCC** algorithm type and attach it to the reason code where the reason type is set to **Success**.

**Note:** You must attach the automatic payment success algorithm to an upload reason which you want to use while freezing automatic payments.

- Create an automatic payment cancel algorithm using the **C1-APAY-CAN** algorithm type and attach it to the reason code where the reason type is set to **Cancel**.

**Note:** You must attach the automatic payment cancel algorithm to an upload reason which you want to use while canceling automatic payments.

- Create a void automatic refund algorithm using the **C1-AREF-VOID** algorithm type and attach it to the reason code where the reason type is set to **Cancel**.

**Note:** You must attach the void automatic refund algorithm to an upload reason which you want to use while voiding automatic refunds.

- Create a characteristic type where the characteristic entity is set to **Payment Tender**. And, then specify this characteristic type as the value for the **Tender Characteristic Type** parameter in an algorithm which is created using the **C1-APAY-SUCC** algorithm type.

- Assign the **C1-ACH** To Do type to a To Do role whose users must receive the To Do entries generated when automatic payments are frozen with a Notice to Change (NOC).
- Assign the **APAYUPTD** To Do type to a To Do role whose users must receive the To Do entries generated when exceptions have occurred while executing the **Freeze or Cancel Automatic Payments (APAYRA)** batch.
- Define values for the following parameters in an algorithm which is created using the **C1-APAY** algorithm type:
  - Line Separator
  - Field Separator
  - Reject Upload Reason
  - Success Upload Reason

## Automatic Payment or Refund Clearing Staging Record Status Transition

The following figure graphically indicates how an automatic payment or refund clearing staging record moves from one status to another during the freeze payments on notification process:

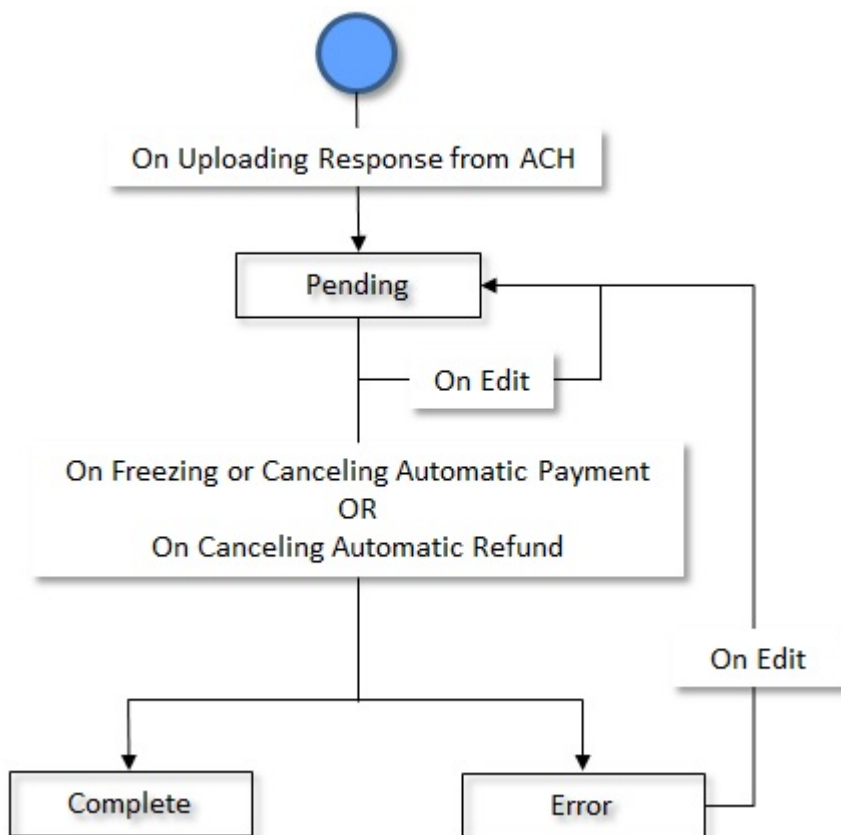

## EDI 824 File Format

Before uploading the EDI 824 file, you need to ensure that the file contains the following tags and attributes:

Tag	Attribute	Description	Mandatory (Yes or No)
OTI	Reference Number	Used to specify the automatic payment clearing ID. It indicates the automatic payment clearing record for which the review comments are received from the auto clearing house.	Yes
OTI	Acknowledgement Code	Used to indicate whether the automatic payment clearing record is accepted or rejected by the auto clearing house. If you want to reject the automatic payment clearing record, you must specify <b>TE</b> or <b>TR</b> as the acknowledgement code. However, if you want to approve the automatic payment clearing record, you can either specify any value other than <b>TE</b> or <b>TR</b> or leave this attribute blank.	No
TED	Error Code	Used to indicate either of the following: <ul style="list-style-type: none"> <li>The payment cancellation reason when the automatic payment clearing record is rejected by the auto clearing house.</li> </ul> <div style="border: 1px solid black; padding: 2px; margin: 5px 0;"><b>Note:</b> You must specify a payment cancellation reason which is already defined in the system.</div> <ul style="list-style-type: none"> <li>The Notice to Change (NOC) reason when the automatic payment clearing record is accepted by the auto clearing house with a Notice to Change (NOC).</li> </ul> <div style="border: 1px solid black; padding: 2px; margin: 5px 0;"><b>Note:</b> You must specify a NOC reason which is already defined in the <b>APAY_UPL_NOC_LOOKUP</b> lookup field.</div>	Yes (Conditional)  <div style="border: 1px solid black; padding: 2px; margin: 5px 0;"><b>Note:</b> This attribute is required when the automatic payment clearing record is rejected by the auto clearing house.</div>
TED	Error Description	Used to specify the reason why the automatic payment clearing record is either rejected or accepted with a Notice to Change (NOC).	No

## Sample EDI 824 File Format

```

OTI*TR*TN*411302586842\
TED*WA01*WRONG ACCOUNT\
OTI*TF*TN*411302525641\
OTI*TO*TN*806152348038\
TED*BR01*Bill Reopened\
OTI*TO*TN*806152307159\
OTI*TE*TN*806152307229\
TED*WA01*WRONG ACCOUNT\

```

Here, TR, TF, TO, and TE are acknowledgement codes. TR and TE indicate that the automatic payment clearing records are rejected. And, TF and TO indicate that the automatic payment clearing records are accepted with or without a Notice to Change (NOC).

Here, 411302586842, 411302525641, 806152348038, 806152307159, and 806152307229 are automatic payment clearing records, and WA01 and BR01 are error codes. WA01 is a payment cancellation reason and BR01 is a NOC reason. The string “WRONG ACCOUNT” and “Bill Reopened” are error descriptions.

For more information about the EDI 824 file format, see [EDI 824 File Format](#) on page 1067.

## Automatic Payment and Refund Upload Reason

Once the auto clearing house reviews the automatic payment and refund clearing records, an appropriate upload reason must be received for each clearing record. The upload reason indicates the following:



- Whether the automatic payment must be frozen or cancelled in the system
- Whether the automatic refund must be canceled in the system (i.e. the refund request must be voided and refund adjustments must be canceled)

The **Automatic Payment and Refund Upload Reason** screen allows you to define, edit, and delete an upload reason. It contains the following zone:

- [Upload Reasons](#) on page 1069

## Upload Reasons

The **Upload Reasons** zone lists upload reasons that are already defined in the system. It contains the following columns:

Column Name	Column Description
Upload Reason	Displays the upload reason.
Reason Type	Indicates the type of upload reason. The valid values are: <ul style="list-style-type: none"> <li>• Cancel</li> <li>• Success</li> </ul>
Eligible for Processing	Indicates whether the algorithms attached to the upload reason must be triggered while executing the <b>Freeze or Cancel Automatic Payments (APAYRA)</b> or <b>Cancel Automatic Refunds (AREFRA)</b> batch. The valid values are: <ul style="list-style-type: none"> <li>• Y</li> <li>• N</li> </ul>
Description	Displays the description of the upload reason.
Edit	On clicking the <b>Edit</b> (  ) icon, the <b>Automatic Payment and Refund Upload Reason</b> screen appears where you can edit the details of the upload reason.
Delete	On clicking the <b>Delete</b> (  ) icon, you can delete the upload reason.

You can define an upload reason by clicking the **Add** link in the upper right corner of this zone.

### Related Topics

For more information on...	See...
How to define an upload reason	<a href="#">Defining an Upload Reason</a> on page 1070
How to edit an upload reason	<a href="#">Editing an Upload Reason</a> on page 1072
How to delete an upload reason	<a href="#">Deleting an Upload Reason</a> on page 1074

## Defining an Upload Reason

### Prerequisites

To define an upload reason, you should have:

- Automatic payment success algorithm defined using the **C1-APAY-SUCC** algorithm type
- Automatic payment cancel algorithm defined using the **C1-APAY-CAN** algorithm type
- Void automatic refund algorithm defined using the **C1-AREF-VOID** algorithm type

### Procedure

To define an upload reason:

1. Click the **Admin** link in the **Application** toolbar.  
A list appears.
2. From the **Admin** menu, select **A** and then click **Automatic Payment and Refund Upload Reason**.  
The **Automatic Payment and Refund Upload Reason** screen appears.
3. Click the **Add** link in the upper right corner of the **Upload Reasons** zone.

The **Automatic Payment and Refund Upload Reason** screen appears. It contains the following fields:



Field Name	Field Description	Mandatory (Yes or No)
Upload Reason	Used to specify the upload reason.	Yes
Description	Used to specify the description for the upload reason.	Yes
Reason Type	Used to indicate the type of upload reason. The valid values are: <ul style="list-style-type: none"> <li>• <b>Cancel</b> — This type of upload reason indicates that you must cancel the automatic payment or refund in the system. In this case, the error code indicates the reason why the automatic payment is cancelled or the refund request is voided.</li> <li>• <b>Success</b> — This type of upload reason indicates that you must freeze the automatic payment on the payment freeze date. If the error code is specified, it indicates that you must freeze the automatic payment, and at the same time notify user that the automatic payment is accepted with a Notice to Change (NOC). The NOC reason is stored as payment tender characteristic in the system. You can specify more than one error code (i.e. NOC reasons) with this type of upload reason. On freezing an automatic payment, the user is notified about these NOC reasons through a To Do entry. The system creates one To Do entry using the <b>C1-ACH</b> To Do type for all NOC reasons specified in the automatic payment clearing staging record.</li> </ul>	Yes

Field Name	Field Description	Mandatory (Yes or No)
Eligible for Processing	Used to indicate whether the algorithms attached to the upload reason must be triggered while executing the <b>Freeze or Cancel Automatic Payments (APAYRA)</b> or <b>Cancel Automatic Refunds (AREFRA)</b> batch.	No

In addition, this screen contains a grid where you can attach algorithms to the upload reason. It contains the following columns:

Column Name	Column Description	Mandatory (Yes or No)
Sequence	Used to indicate the order in which the algorithm must be triggered.	Yes (Conditional) <b>Note:</b> This field is required when you are attaching an algorithm to the upload reason.
Algorithm	Used to attach an algorithm to the upload reason. If the type of the upload reason is set to <b>Success</b> , you must attach the automatic payment success algorithm. However, if the type of the upload reason is set to <b>Cancel</b> , you must attach either automatic payment cancel or void automatic refund algorithm depending on whether the upload reason will be used for automatic payment or automatic refund cancelation.  <b>Note:</b> The <b>Search</b>  icon appears corresponding to this field. On clicking the <b>Search</b> icon, the <b>Algorithm Code Search</b> window appears. On specifying the algorithm code, the description of the algorithm appears corresponding to the <b>Algorithm</b> field.	Yes (Conditional) <b>Note:</b> This field is required when you are attaching an algorithm to the upload reason.

- Enter the required details in the **Automatic Payment and Refund Upload Reason** screen.

**Note:** If you want to attach more than one algorithm to the upload reason, click the **Add**  icon and then specify the details. However, if you want to remove an algorithm from the upload reason, click the **Delete**  icon corresponding to the algorithm.

- Click **Save**.

The upload reason is defined.

### Related Topics

For more information on...	See...
<b>Automatic Payment and Refund Upload Reason</b> screen	<a href="#">Automatic Payment and Refund Upload Reason</a> on page 1069
<b>Upload Reasons</b> zone	<a href="#">Upload Reasons</a> on page 1069

## Editing an Upload Reason

### Prerequisites

To edit an upload reason, you should have:

- Automatic payment success algorithm defined using the **C1-APAY-SUCC** algorithm type
- Automatic payment cancel algorithm defined using the **C1-APAY-CAN** algorithm type
- Void automatic refund algorithm defined using the **C1-AREF-VOID** algorithm type

### Procedure

To edit an upload reason:

1. Click the **Admin** link in the **Application** toolbar.

A list appears.

2. From the **Admin** menu, select **A** and then click **Automatic Payment and Refund Upload Reason**.

The **Automatic Payment and Refund Upload Reason** screen appears.

3. In the **Upload Reasons** zone, click the **Edit** (✎) icon in the **Edit** column corresponding to the upload reason whose details you want to edit.

The **Automatic Payment and Refund Upload Reason** screen appears. It contains the following fields:

Field Name	Field Description	Mandatory (Yes or No)
Upload Reason	Displays the upload reason.	Not applicable
Description	Used to specify the description for the upload reason.	Yes
Reason Type	Used to indicate the type of upload reason. The valid values are: <ul style="list-style-type: none"> <li>• <b>Cancel</b> — This type of upload reason indicates that you must cancel the automatic payment or refund in the system. In this case, the error code indicates the reason why the automatic payment is cancelled or the refund request is voided.</li> <li>• <b>Success</b> — This type of upload reason indicates that you must freeze the automatic payment on the payment freeze date. If the error code is specified, it indicates that you must freeze the automatic payment, and at the same time notify user that the automatic payment is accepted with a Notice to Change (NOC). The NOC reason is stored as payment tender characteristic in the system. You can specify more than one error code (i.e. NOC reasons) with this type of upload reason. On freezing an automatic payment, the user is notified about these NOC reasons through a To Do entry. The system creates one To Do entry using the <b>C1-ACH</b> To Do type for all NOC reasons specified in the automatic payment clearing staging record.</li> </ul>	Yes





Field Name	Field Description	Mandatory (Yes or No)
Eligible for Processing	Used to indicate whether the algorithms attached to the upload reason must be triggered while executing the <b>Freeze or Cancel Automatic Payments (APAYRA)</b> or <b>Cancel Automatic Refunds (AREFRA)</b> batch.	No

In addition, this screen contains a grid where you can attach algorithms to the upload reason. It contains the following columns:

Column Name	Column Description	Mandatory (Yes or No)
Sequence	Used to indicate the order in which the algorithm must be triggered.	Yes (Conditional) <b>Note:</b> This field is required when you are attaching an algorithm to the upload reason.
Algorithm	Used to attach an algorithm to the upload reason. If the type of the upload reason is set to <b>Success</b> , you must attach the automatic payment success algorithm. However, if the type of the upload reason is set to <b>Cancel</b> , you must attach either automatic payment cancel or void automatic refund algorithm depending on whether the upload reason will be used for automatic payment or automatic refund cancelation.  <b>Note:</b> The <b>Search</b>  icon appears corresponding to this field. On clicking the <b>Search</b> icon, the <b>Algorithm Code Search</b> window appears. On specifying the algorithm code, the description of the algorithm appears corresponding to the <b>Algorithm</b> field.	Yes (Conditional) <b>Note:</b> This field is required when you are attaching an algorithm to the upload reason.

4. Modify the required details in the **Automatic Payment and Refund Upload Reason** screen.

**Note:** If you want to attach more than one algorithm to the upload reason, click the **Add**  icon and then specify the details. However, if you want to remove an algorithm from the upload reason, click the **Delete**  icon corresponding to the algorithm.

5. Click **Save**.

The changes made to the upload reason are saved.

### Related Topics

For more information on...	See...
<b>Automatic Payment and Refund Upload Reason</b> screen	<a href="#">Automatic Payment and Refund Upload Reason</a> on page 1069
<b>Upload Reasons</b> zone	<a href="#">Upload Reasons</a> on page 1069

## Deleting an Upload Reason

### Procedure

To delete an upload reason:

1. Click the **Admin** link in the **Application** toolbar.  
A list appears.
2. From the **Admin** menu, select **A** and then click **Automatic Payment and Refund Upload Reason**.  
The **Automatic Payment and Refund Upload Reason** screen appears.
3. In the **Upload Reasons** zone, click the **Delete** (🗑️) icon in the **Delete** column corresponding to the upload reason that you want to delete.  
A message appears confirming whether you want to delete the upload reason.
4. Click **OK**.  
The upload reason is deleted.

### Related Topics

For more information on...	See...
<b>Automatic Payment and Refund Upload Reason</b> screen	<a href="#">Automatic Payment and Refund Upload Reason</a> on page 1069
<b>Upload Reasons</b> zone	<a href="#">Upload Reasons</a> on page 1069

## Automatic Payment and Refund Clearing Staging

The **Automatic Payment and Refund Clearing Staging** screen allows you to search for automatic payment or refund clearing records using various search criteria. In addition, you can:

- View the automatic payment or refund clearing staging records associated to a clearing record
- View the upload reason and payment cancelation reason or NOC reason specified in the automatic payment clearing staging record
- View the upload reason and void status reason specified in the automatic refund clearing staging record
- View the characteristics defined for the automatic payment or refund clearing staging record
- Edit an automatic payment or refund clearing staging record
- Delete an automatic payment or refund clearing staging record

This screen contains the following zones:

- [Search Clearing Record](#) on page 1075
- [Associated Clearing Staging Records](#) on page 1077
- [Clearing Staging Upload Reasons](#) on page 1078
- [Clearing Staging Characteristics](#) on page 1078

## Search Clearing Record

The **Search Clearing Record** zone allows you to search for automatic payment and refund clearing records using various search criteria. It contains the following two sections:

- **Search Criteria** — the **Search Criteria** section contains the following fields:

Field Name	Field Description	Mandatory (Yes or No)
Search By	Used to indicate whether you want to search for the automatic payment or refund clearing records. The valid values are: <ul style="list-style-type: none"> <li>• Automatic Payment</li> <li>• Automatic Refund</li> </ul>	Yes
Clearing ID	Used to search a particular clearing record.	No
Account ID	Used to search clearing records which are created for a particular account. <div style="border: 1px solid black; padding: 5px; margin-top: 10px;"> <p><b>Note:</b> The <b>Search</b>  icon appears corresponding to this field. On clicking the <b>Search</b> icon, the <b>Account Search</b> window appears.</p> </div>	No
Person Name	Used to search clearing records which are created for accounts of a particular person.	No
Extract From Date	Used to search clearing records that are extracted on or after a particular date.	No
Extract To Date	Used to search clearing records that are extracted on or before a particular date.	No
Bill ID	Used to search clearing records which are created against a bill.	No
Alternate Bill ID	Used to search clearing records which are created against a bill with the specified alternate bill ID.	No
Batch Control	Used to search clearing records where the <b>APAYACH</b> batch control is stamped. The valid value is <b>APAYACH</b> .	No
Batch Run Number	Used to search clearing records which are activated in a particular batch run.	No

**Note:** You must specify at least one search criterion while searching for a clearing record.

- **Search Results** — On clicking the **Search** button, the search results appear based on the specified search criteria. The **Search Results** section contains the following columns:

Column Name	Column Description
Clearing ID	Displays the clearing ID.

Column Name	Column Description
Account Information	<p>Indicates the account for which the clearing record is created. In addition, this column has a context menu which helps in navigating to other screens in the application.</p> <p><b>Note:</b> It has a link. On clicking the link, the <b>Account</b> screen appears with the details of the respective account.</p>
Bill Information	<p>Indicates the bill against which the clearing record is created. In addition, this column has a context menu which helps in navigating to other screens in the application.</p> <p><b>Note:</b> It has a link. On clicking the link, the <b>Bill</b> screen appears with the details of the respective bill.</p>
Payment Amount	<p>Displays the payment amount.</p> <p><b>Note:</b> This column appears only when you select the <b>Automatic Payment</b> option from the <b>Search By</b> list.</p>
Pay Tender ID	<p>Displays the payment tender ID.</p> <p><b>Note:</b> It has a link. On clicking the link, the <b>Payment Event</b> screen appears where you can view the details of the respective tender. This column appears only when you select the <b>Automatic Payment</b> option from the <b>Search By</b> list.</p>
Tender Status	<p>Indicates the current status of the payment tender. The valid values are:</p> <ul style="list-style-type: none"> <li>Valid</li> <li>Canceled</li> </ul> <p><b>Note:</b> This column appears only when you select the <b>Automatic Payment</b> option from the <b>Search By</b> list.</p>
Extract Date	<p>Displays the date when the clearing record is extracted in a flat file.</p>
Payment Freeze Date	<p>Displays the date when the automatic payment must be frozen in the system.</p> <p><b>Note:</b> This column appears only when you select the <b>Automatic Payment</b> option from the <b>Search By</b> list.</p>
External Source ID	<p>Indicates the tender source through which the payment was remitted.</p>
Entity Type	<p>Indicates the type of entity which is created for automatic refund. The valid value is:</p> <ul style="list-style-type: none"> <li>Refund Request</li> </ul> <p><b>Note:</b> This column appears only when you select the <b>Automatic Refund</b> option from the <b>Search By</b> list.</p>
Entity ID	<p>Displays the entity ID.</p> <p><b>Note:</b> This column appears only when you select the <b>Automatic Refund</b> option from the <b>Search By</b> list.</p>



Column Name	Column Description
Account Number	Indicates the bank account through which the automatic payment is made.
Batch Control	Indicates the batch control which is stamped on the clearing record.
Batch Run Number	Indicates the batch run in which the clearing record was activated.
Alternate Bill ID	Indicates the bill against which the clearing record is created.

### Related Topics

For more information on...	See...
How to search for a clearing record	<a href="#">Searching for a Clearing Record</a> on page 1079

## Associated Clearing Staging Records

The **Associated Clearing Staging Records** zone lists the automatic payment or refund clearing staging records which are added corresponding to the clearing record. You can edit and delete an automatic payment or refund clearing staging record through this zone. It contains the following columns:

Column Name	Column Description
Clearing Staging ID	Displays the clearing staging ID.
Clearing ID	Indicates the clearing record against which the clearing staging record is added.
Status	Indicates the status of the clearing staging record. The valid values are: <ul style="list-style-type: none"> <li>• Pending</li> <li>• Complete</li> <li>• Error</li> </ul>
Edit	On clicking the <b>Edit</b> (  ) icon, the <b>Edit Clearing Staging Record</b> screen appears where you can edit the details of the clearing staging record. <div style="border: 1px solid black; padding: 5px; margin-top: 10px;"> <p><b>Note:</b> You can edit a clearing staging record only when it is in the <b>Pending</b> or <b>Error</b> status.</p> </div>
Delete	On clicking the <b>Delete</b> (  ) icon, you can delete the clearing staging record. <div style="border: 1px solid black; padding: 5px; margin-top: 10px;"> <p><b>Note:</b> You can delete a clearing staging record only when it is in the <b>Pending</b> status.</p> </div>

By default, the **Associated Clearing Staging Records** zone does not appear in the **Automatic Payment and Refund Clearing Staging** screen. It appears only when you click the **Broadcast** () icon corresponding to the clearing record in the **Search Clearing Record** zone.

### Related Topics

For more information on...	See...
How to view the clearing staging records associated to a clearing record	<a href="#">Viewing the Clearing Staging Records Associated to a Clearing Record</a> on page 1079
How to edit a clearing staging record	<a href="#">Editing a Clearing Staging Record</a> on page 1081
How to delete a clearing staging record	<a href="#">Deleting a Clearing Staging Record</a> on page 1083

## Clearing Staging Upload Reasons

The **Clearing Staging Upload Reasons** zone lists the reason code (i.e. upload reason) and error code (i.e. payment cancellation reason, Notice to Change (NOC) reasons, or void status reason) specified in the automatic payment or refund clearing staging record. It contains the following columns:

Column Name	Column Description
Sequence	Indicates the sequence in which the upload reason should be considered while freezing or canceling the automatic payment or while canceling the automatic refund.
Clearing Staging ID	Displays the clearing staging ID.
Clearing ID	Indicates the clearing record against which the clearing staging record is added.
Upload Reason	Indicates whether the auto clearing house has accepted or rejected the clearing record.
Cancel Reason	Indicates the reason why the auto clearing house has rejected the clearing record. If the clearing record is created for an automatic payment, the payment cancellation reason appears in this column. However, if the clearing record is created for an automatic refund, the void status reason appears in this column.
NOC Reason	Indicates the reason why the auto clearing house has accepted the clearing record with a Notice to Change (NOC).
NOC Reason Description	Displays the description of the NOC reason.

By default, the **Clearing Staging Upload Reasons** zone does not appear in the **Automatic Payment and Refund Clearing Staging** screen. It appears only when you click the **Broadcast**  icon corresponding to the clearing staging record in the **Associated Clearing Staging Records** zone.

### Related Topics

For more information on...	See...
How to view the upload reason specified in the clearing staging record	<a href="#">Viewing the Upload Reason Specified in the Clearing Staging Record</a> on page 1080

## Clearing Staging Characteristics

The **Clearing Staging Characteristics** zone lists the characteristics defined for the automatic payment or refund clearing staging record. It contains the following columns:

Column Name	Column Description
Clearing Staging ID	Displays the clearing staging ID.
Clearing ID	Indicates the clearing record against which the clearing staging record is added.
Characteristic Type	Indicates the characteristic type.
Characteristic Value	Displays the characteristic value.

By default, the **Clearing Staging Characteristics** zone does not appear in the **Automatic Payment and Refund Clearing Staging** screen. It appears only when you click the **Broadcast**  icon corresponding to the clearing staging record in the **Associated Clearing Staging Records** zone.

### Related Topics

For more information on...	See...
How to view the characteristics of the clearing staging record	<a href="#">Viewing the Characteristics of the Clearing Staging Record</a> on page 1080

## Searching for a Clearing Record

### Procedure

To search for a clearing record:

1. Click the **Menu** link in the **Application** toolbar.  
A list appears.
2. From the **Main** menu, select **Financial** and then click **Automatic Payment and Refund Clearing Staging**.  
The **Automatic Payment and Refund Clearing Staging** screen appears.
3. Enter the search criteria in the **Search Clearing Record** zone depending on whether you want to search for automatic payment or refund clearing records.

**Note:** ORMB search engine supports wildcard search, where you can substitute the percentage (%) symbol as a stand in for any word or letter in a search criteria. You can use the ‘%’ wildcard character in all input fields except the date and ID fields. The ‘%’ wildcard character is suffixed automatically at the end of the partial search criteria. Therefore, you may or may not specify the wildcard character at the end of the partial search criteria. However, you have to prefix the wildcard character manually wherever required.

4. Click **Search**.

A list of clearing records that meet the search criteria appears in the **Search Results** section.

### Related Topics

For more information on...	See...
<b>Automatic Payment and Refund Clearing Staging</b> screen	<a href="#">Automatic Payment and Refund Clearing Staging</a> on page 1074
<b>Search Clearing Record</b> zone	<a href="#">Search Clearing Record</a> on page 1075

## Viewing the Clearing Staging Records Associated to a Clearing Record

### Procedure

To view the clearing staging records associated to a clearing record:

1. Search for the clearing record in the **Automatic Payment and Refund Clearing Staging** screen.
2. In the **Search Results** section, click the **Broadcast**  icon corresponding to the clearing record whose associated clearing staging records you want to view.  
The **Associated Clearing Staging Records** zone appears.
3. View the details of the clearing staging records in the **Associated Clearing Staging Records** zone.

### Related Topics



For more information on...	See...
How to search for a clearing record	<a href="#">Searching for a Clearing Record</a> on page 1079

For more information on...	See...
Associated Clearing Staging Records zone	<a href="#">Associated Clearing Staging Records</a> on page 1077

## Viewing the Upload Reason Specified in the Clearing Staging Record

### Procedure

To view the upload reason specified in the clearing staging record:

1. Search for the clearing record in the **Automatic Payment and Refund Clearing Staging** screen.
2. In the **Search Results** section, click the **Broadcast**  icon corresponding to the clearing record whose associated clearing staging records you want to view.  
  
The **Associated Clearing Staging Records** zone appears.
3. In the **Associated Clearing Staging Records** zone, click the **Broadcast**  icon corresponding to the clearing staging record whose details you want to view.  
  
The **Clearing Staging Upload Reasons** and **Clearing Staging Characteristics** zones appear.
4. View the reason and error codes specified in the clearing staging record in the **Clearing Staging Upload Reasons** zone.



### Related Topics

For more information on...	See...
How to search for a clearing record	<a href="#">Searching for a Clearing Record</a> on page 1079
Associated Clearing Staging Records zone	<a href="#">Associated Clearing Staging Records</a> on page 1077
Clearing Staging Upload Reasons zone	<a href="#">Clearing Staging Upload Reasons</a> on page 1078

## Viewing the Characteristics of the Clearing Staging Record

### Procedure

To view the characteristics of the clearing staging record:

1. Search for the clearing record in the **Automatic Payment and Refund Clearing Staging** screen.
2. In the **Search Results** section, click the **Broadcast**  icon corresponding to the clearing record whose associated clearing staging records you want to view.  
  
The **Associated Clearing Staging Records** zone appears.
3. In the **Associated Clearing Staging Records** zone, click the **Broadcast**  icon corresponding to the clearing staging record whose details you want to view.  
  
The **Clearing Staging Upload Reasons** and **Clearing Staging Characteristics** zones appear.
4. View the characteristics of the clearing staging record in the **Clearing Staging Characteristics** zone.

### Related Topics



For more information on...	See...
How to search for a clearing record	<a href="#">Searching for a Clearing Record</a> on page 1079
<b>Associated Clearing Staging Records</b> zone	<a href="#">Associated Clearing Staging Records</a> on page 1077
<b>Clearing Staging Characteristics</b> zone	<a href="#">Clearing Staging Characteristics</a> on page 1078

## Editing a Clearing Staging Record

### Prerequisites

To edit a clearing staging record, you should have:

- Upload reasons defined in the application
- NOC reasons defined in the **APAY\_UPL\_NOC\_LOOKUP** lookup field.
- Payment cancelation reasons defined in the application
- Reasons defined for the **Voided** status of the **C1-RefundReq** business object in the **Status Reason** screen

**Note:** You can edit a clearing staging record only when it is in the **Pending** or **Error** status. On editing a clearing staging record which is in the **Error** status, the status of the clearing staging record is changed to **Pending**. Also, the exceptions logged for the clearing staging record are deleted from the **CI\_APAY\_STGUP\_EXC** table.

### Procedure

To edit a clearing staging record:

1. Search for the clearing record in the **Automatic Payment and Refund Clearing Staging** screen.
2. In the **Search Results** section, click the **Broadcast**  icon corresponding to the clearing record whose associated clearing staging record you want to edit.

The **Associated Clearing Staging Records** zone appears.

3. In the **Associated Clearing Staging Records** zone, click the **Edit**  icon in the **Edit** column corresponding to the clearing staging record whose details you want to edit.

The **Edit Clearing Staging Record** screen appears. It contains the following fields:

Field Name	Field Description	Mandatory (Yes or No)
Clearing Staging ID	Displays the clearing staging ID.	Not applicable
Clearing ID	Indicates the clearing record against which the clearing staging record is added.	Not applicable
Status	Indicates the status of the clearing staging record. The valid values are: <ul style="list-style-type: none"> <li>• Pending</li> <li>• Complete</li> <li>• Error</li> </ul>	Not applicable
Upload Date	Used to specify the date when the clearing staging record was uploaded or added in the system.	Yes

In addition, this screen contains the following two sections:

- **Upload Reasons** — Used to add, edit, or remove the reason code (i.e. upload reason) and error (sub reason) codes from the clearing staging record. It contains the following fields in a grid:

Field Name	Field Description	Mandatory (Yes or No)
Upload Reason	Used to specify the upload reason. It indicates whether the auto clearing house has accepted or rejected the clearing record.	Yes
Reason Type	Used to indicate the type of upload reason. The valid values are: <ul style="list-style-type: none"> <li>• Cancel</li> <li>• Success</li> </ul>	Yes
Sub Reason Code	Used to specify either of the following: <ul style="list-style-type: none"> <li>• Payment cancelation reason or void status reason (for automatic refund) when the reason type is set to <b>Cancel</b></li> <li>• Notice to Change (NOC) reason when the reason type is set to <b>Success</b></li> </ul>	No
Sub Reason Description	Used to specify the description of the NOC reason.	No

**Note:** The upload reason, payment cancelation reason, void status reason, and NOC reasons must be already defined in the system. If you specify an invalid reason and sub reason codes, the status of the clearing staging record is changed to **Error** when you execute the **Freeze or Cancel Automatic Payments (APAYRA)** or **Cancel Automatic Refunds (AREFRA)** batch.

- **Characteristics** — Used to define characteristics for the clearing staging record.
4. Modify the required details in the **Edit Clearing Staging Record** screen.

**Note:** If you want to add more than one reason or sub reason code, click the **Add** (+) icon in the **Upload Reasons** section and then specify the required details. However, if you want to remove a reason or sub reason code, click the **Delete** (🗑️) icon corresponding to the reason.

5. Define characteristics for the clearing staging record, if required.
6. Click **Save**.

The changes made to the clearing staging record are saved.

### **Related Topics**

For more information on...	See...
How to search for a clearing record	<a href="#">Searching for a Clearing Record</a> on page 1079
<b>Associated Clearing Staging Records</b> zone	<a href="#">Associated Clearing Staging Records</a> on page 1077
How to define characteristics for a clearing staging record	<a href="#">Defining Characteristics for a Clearing Staging Record</a> on page 1082

## **Defining Characteristics for a Clearing Staging Record**

### **Prerequisites**

To define characteristics for a clearing staging record, you should have:

- Characteristic types defined in the application (where the characteristic entity is set to **Auto Payment Upload**)

### **Procedure**

To define characteristics for a clearing staging record:

1. Ensure that the **Characteristics** section is expanded when you are editing a clearing staging record.

The **Characteristics** section contains the following fields in a grid:

Field Name	Field Description	Mandatory (Yes or No)
Effective Date	Used to specify the date from when the characteristic is effective for the clearing staging record.	Yes (Conditional) <b>Note:</b> This field is required when you are defining a characteristic for the clearing staging record.
Characteristic Type	Used to indicate the characteristic type. <b>Note:</b> The list includes only those characteristic types where the characteristic entity is set to <b>Auto Payment Upload</b> .	Yes (Conditional) <b>Note:</b> This field is required when you are defining a characteristic for the clearing staging record.
Characteristic Value	Used to specify the value for the characteristic type. <b>Note:</b> On specifying the value for a predefined characteristic type, the description of the characteristic value appears corresponding to the <b>Characteristic Value</b> field.	Yes (Conditional) <b>Note:</b> This field is required when you are defining a characteristic for the clearing staging record.

2. Enter the required details in the **Characteristics** section.

**Note:** If you select a predefined characteristic type, the **Search**  icon appears corresponding to the **Characteristic Value** field. On clicking the **Search** icon, you can search for a predefined characteristic value.

3. If you want to define more than one characteristic for the clearing staging record, click the **Add**  icon and then repeat step 2.

**Note:** However, if you want to remove a characteristic from the clearing staging record, click the **Delete**  icon corresponding to the characteristic.

### **Related Topics**

For more information on...	See...
How to edit a clearing staging record	<a href="#">Editing a Clearing Staging Record</a> on page 1081

## **Deleting a Clearing Staging Record**

### **Procedure**

To delete a clearing staging record:

1. Search for the clearing record in the **Automatic Payment and Refund Clearing Staging** screen.

2. In the **Search Results** section, click the **Broadcast**  icon corresponding to the clearing record whose associated clearing staging record you want to delete.

The **Associated Clearing Staging Records** zone appears.

3. In the **Associated Clearing Staging Records** zone, click the **Delete**  icon in the **Delete** column corresponding to the clearing staging record that you want to delete.

A message appears confirming whether you want to delete the clearing staging record.

**Note:** You can delete a clearing staging record only when it is in the **Pending** status.

4. Click **OK**.

The clearing staging record is deleted.

### **Related Topics**

<b>For more information on...</b>	<b>See...</b>
How to search for a clearing record	<a href="#">Searching for a Clearing Record</a> on page 1079
<b>Associated Clearing Staging Records</b> zone	<a href="#">Associated Clearing Staging Records</a> on page 1077

---

# Chapter 14

---

## Trial Billing

---

### Topics:

- [Trial Bill \(Used for Searching\)](#)
- [Trial Bill \(Used for Viewing\)](#)

Oracle Revenue Management and Billing facilitates you to generate trial bills before actual bill is generated for an account. This helps to review the trial bill and make the required corrections before the actual bill is generated. The Trial Billing feature is currently designed and developed for open item accounting and not for balance forward accounting.

The process of trial and actual billing is identical. The only difference is that you cannot freeze and complete the trial bills. Also, during trial billing, the account balance is not updated. It is updated only when the actual bill is generated. You can generate trial bill only in case of regular billing, and not in case of adhoc billing. The trial bills can be generated only through the batch process. To generate trial bills, you need to execute the following batches in the specified order:

1. **Pending Bill Generation (C1-PNDBL)** – This batch is used to generate pending trial or actual bills for accounts that meet the criteria.
2. **Bill Segment Generation (C1-BLGEN)** – This batch is used to generate bill segments for pending trial or actual bills.
3. **Bill Completion (C1-BLPPR)** – This batch is used to generate post-processing bill segments in the pending trial or actual bills during the bill completion process. The adjustments, if any, created on the accounts are swept onto the pending trial or actual bills. In addition, the bill routing information and bill messages are stamped on the pending trial or actual bills. If the adjustment currency is different from the account's invoice currency, the transfer adjustment is created on the pending actual bill. However, in case of pending trial bill, the currency conversion for adjustments is done, but the transfer adjustments are not created. Finally, the status of the actual bill is set to **Complete**, whereas the status of the trial bill remains as **Pending**.

**Note:** The adjustments which are in the **Freezable** status are not swept onto the trial bills. Only adjustments which are in the **Frozen** status are swept onto the trial bills.

The **Trial Bill** check box is added in the **Main** tab of the **Account** screen. If you leave the **Process All or Selected Accounts** parameter blank while executing the above batches, all accounts (that meet the criteria) irrespective of whether the **Trial Bill** check box is selected or not are considered for generating the trial bills. However, if the **Process All or Selected Accounts** parameter is set to **Y**, then only those accounts that meet the criteria and where the **Trial Bill** check box is selected are considered for generating the trial bills.

You can create an actual bill using a trial bill. While creating actual bills using trial bills, you need to specify the trial billing batch run number whose trial bills

you want to convert to the actual bills. To create actual bills using trial bills, you need to execute the following batches in the specified order:

1. **Pending Bill Generation (C1-PNDBL)** - This batch generates pending actual bill for accounts that meet the criteria.
2. **Bill Segment Generation (C1-BLGEN)** – This batch copies regular bill segments which are generated for the trial bill and stamps them onto the pending actual bill. It also copies the corresponding financial transactions (FTs).
3. **Bill Completion (C1-BLPPR)** – This batch copies post-processing bill segments which are generated for the trial bill and stamps them onto the pending actual bill. The bill routing information and bill messages are copied from the trial bill to the pending actual bill. The adjustment, if any, created on the account are swept onto the pending actual bill. They are not copied from the respective trial bill. If the adjustment currency is different from the account's invoice currency, the transfer adjustment is created on the pending actual bill. Finally, the status of the actual bill is set to **Complete**.

The actual bill ID, bill segment ID and FT ID are different from the trial bill ID, bill segment ID and FT ID, respectively. If an actual bill is created using a trial bill, the system will stamp the trial bill ID on the actual bill. This helps you to track the trial bill of an actual bill.

The system allows you to view a trial bill through a user interface. It also allows you to print the trial bill in the PDF format. You can print a trial bill only when Oracle Documaker is integrated with Oracle Revenue Management and Billing. For more information about the batches, see *Oracle Revenue Management and Billing Batch Guide*.

## Trial Bill (Used for Searching)

The **Trial Bill** screen allows you to search for a trial bill using various search criteria. It contains the following zone:

- [Search Trial Bill](#) on page 1087



Through this screen, you can navigate to the following screen:

- [Trial Bill \(Used for Viewing\)](#) on page 1090

### Search Trial Bill

The **Search Trial Bill** zone allows you to search for trial bills using various search criteria. It contains the following two sections:

- **Search Criteria** — The criteria are grouped as indicated by line separators between the criteria. Each group is independent from the other, and only one group is used at a time for searching. If you enter criteria in more than one group, the criteria from the first group is used for searching. For example, if you enter the criteria in the Account ID and Trial Bill Description fields (which are in different criteria groups), the system searches for trial bills using the account ID. The **Search Criteria** section contains the following fields:

Field Name	Field Description	Mandatory (Yes or No)
Search By	Used to indicate whether you want to search for a trial bill using the trial bill details. The valid value is: <ul style="list-style-type: none"> <li>• Trial Bill Details</li> </ul> <div style="border: 1px solid black; padding: 2px; margin-top: 5px;"> <b>Note:</b> By default, the <b>Trial Bill Details</b> option is selected.         </div>	Yes
Person ID	Used to search trial bills which are generated for a particular person. <div style="border: 1px solid black; padding: 2px; margin-top: 5px;"> <b>Note:</b> The <b>Search</b>  icon appears corresponding to this field. On clicking the <b>Search</b> icon, the <b>Person Search</b> window appears.         </div>	No
Trial Bill ID	Used to search for a particular trial bill.	No
Account ID	Used to search trial bills which are generated for a particular account. <div style="border: 1px solid black; padding: 2px; margin-top: 5px;"> <b>Note:</b> The <b>Search</b>  icon appears corresponding to this field. On clicking the <b>Search</b> icon, the <b>Account Search</b> window appears.         </div>	No
Division	Used to search trial bills which are generated for accounts belonging to a particular division.	No
From Trial Bill Date	Used to search trial bills which are generated from a particular date onwards.	No
Invoice Currency	Used to search trial bills which are generated in a particular invoice currency.	No
To Trial Bill Date	Used to search trial bills which are generated till a particular date.	No

Field Name	Field Description	Mandatory (Yes or No)
Batch Run Date	Used to search trial bills which are generated on a particular batch run date.	No
Trial Bill Description	Used to search trial bills which are generated in a particular batch run.	Yes (Conditional) <b>Note:</b> This field is required when you are searching for trial bills using the batch run date.

**Note:** You must specify at least one search criterion while searching for a trial bill.

- **Search Results** — On clicking the **Search** button, the search results appear based on the specified search criteria. The **Search Results** section contains the following columns:

Column Name	Column Description
Trial Bill Information	Displays additional information about the trial bill. <b>Note:</b> It has a link. On clicking the link, the <b>Trial Bill</b> screen appears where you can view the details of the respective trial bill.
Current Charges	Displays the trial bill amount.
Account Information	Indicates the account for which the trial bill is generated. In addition, this column has a context menu which helps in navigating to other screens in the application. <b>Note:</b> It has a link. On clicking the link, the <b>Account</b> screen appears with the details of the respective account.
Person Name	Indicates the person for whom the trial bill is generated.
Division	Indicates the division to which the account belongs.
Batch Run Date	Displays the date when the batch is executed to generate the trial bill.
Batch Run Number	Indicates the batch run in which the trial bill is generated.

### Related Topics

For more information on...	See...
How to search for a trial bill	<a href="#">Searching for a Trial Bill</a> on page 1088
How to view the details of a trial bill	<a href="#">Viewing the Trial Bill Details</a> on page 1089

## Searching for a Trial Bill

### Prerequisites

To search for a trial bill, you should have:

- Divisions and currencies defined in the application

### Procedure

To search for a trial bill:

1. Click the **Menu** link in the **Application** toolbar.

A list appears.



- From the **Main** menu, select **Financial** and then click **Trial Bill**.

The **Trial Bill** screen appears.

- Enter the search criteria in the **Search Trial Bill** zone.

**Note:** ORMB search engine supports wildcard search, where you can substitute the percentage (%) symbol as a stand in for any word or letter in a search criteria. You can use the ‘%’ wildcard character in all input fields except the date and ID fields. The ‘%’ wildcard character is suffixed automatically at the end of the partial search criteria. Therefore, you may or may not specify the wildcard character at the end of the partial search criteria. However, you have to prefix the wildcard character manually wherever required.

- Click **Search**.

A list of trial bills that meet the search criteria appears in the **Search Results** section.

### Related Topics

For more information on...	See...
<b>Trial Bill</b> screen	<a href="#">Trial Bill (Used for Searching)</a> on page 1087
<b>Search Trial Bill</b> zone	<a href="#">Search Trial Bill</a> on page 1087

## Viewing the Trial Bill Details

### Procedure

To view the details of a trial bill:

- Search for the trial bill in the **Trial Bill** screen.
- In the **Search Results** section, click the link in the **Trial Bill Information** column corresponding to the trial bill whose details you want to view.  
The **Trial Bill** screen appears.
- View the basic details of the trial bill in the **Trial Bill** zone.
- View the segments of the trial bill in the **Trial Bill Segments** zone.
- View the calc lines of a trial bill segment in the **Trial Bill Segment Calc Lines** zone.
- View the service quantity details of a trial bill segment in the **Trial Bill Segment SQ Details** zone.
- View the financial details of a trial bill segment in the **Trial Bill Segment Financial Details** zone.

### Related Topics

For more information on...	See...
How to search for a trial bill	<a href="#">Searching for a Trial Bill</a> on page 1088
<b>Trial Bill</b> screen	<a href="#">Trial Bill (Used for Viewing)</a> on page 1090
<b>Trial Bill</b> zone	<a href="#">Trial Bill</a> on page 1090
<b>Trial Bill Segments</b> zone	<a href="#">Trial Bill Segments</a> on page 1091
<b>Trial Bill Segment Calc Lines</b> zone	<a href="#">Trial Bill Segment Calc Lines</a> on page 1093
<b>Trial Bill Segment SQ Details</b> zone	<a href="#">Trial Bill Segment SQ Details</a> on page 1094
<b>Trial Bill Segment Financial Details</b> zone	<a href="#">Trial Bill Segment Financial Details</a> on page 1094

For more information on...	See...
How to view the segments of a trial bill	<a href="#">Viewing the Segments of a Trial Bill</a> on page 1095
How to view the calc lines of a trial bill segment	<a href="#">Viewing the Calc Lines of a Trial Bill Segment</a> on page 1096
How to view the service quantity details of a trial bill segment	<a href="#">Viewing the SQ Details of a Trial Bill Segment</a> on page 1097
How to view the financial details of a trial bill segment	<a href="#">Viewing the Financial Details of a Trial Bill Segment</a> on page 1098

## Trial Bill (Used for Viewing)

The **Trial Bill** screen allows you to:

- View the details of a trial bill, such as the trial bill summary, trial bill messages, and trial bill characteristics
- View the segments of a trial bill
- View the calculation lines, service quantity details, and financial details of a trial bill segment

It contains the following zones:

- [Trial Bill](#) on page 1090
- [Trial Bill Segments](#) on page 1091
- [Trial Bill Segment Calc Lines](#) on page 1093
- [Trial Bill Segment SQ Details](#) on page 1094
- [Trial Bill Segment Financial Details](#) on page 1094

### Trial Bill

The **Trial Bill** zone displays the details of the trial bill. It contains the following sections:

- **Main** — This section provides basic information about the trial bill. It contains the following fields:

Field Name	Field Description
Trial Bill ID	Displays the trial bill ID.
Trial Bill Information	Displays additional information about the trial bill.
Trial Bill Description	Displays the description of the batch run in which the trial bill is generated.
Account Information	Indicates the account for which the trial bill is generated. In addition, a context menu appears corresponding to this field which helps in navigating to other screens in the application.  <b>Note:</b> It has a link. On clicking the link, the <b>Account</b> screen appears where you can view the details of the respective account.

- **Trial Bill Summary** — This section summarizes the financial impact of the bill. It contains the following fields:

Field Name	Field Description
New Charges	Displays the total amount of frozen bill segment financial transactions which are linked to the trial bill.
Adjustments	Displays the total amount of frozen and/or canceled adjustment financial transactions which are linked to the trial bill.
Corrections	Displays the total amount of canceled and/or rebilled bill segment financial transactions which are linked to the trial bill.
Total	Displays the sum of new charges, adjustments, and corrections.
No. of Bill Segments in Error	Indicates the number of bill segments in the trial bill which are in the <b>Error</b> status.

- **Trial Bill Messages** — This section lists the bill messages that are stamped on the trial bill. It contains the following columns:

Column Name	Column Description
Message Code	Displays the code that uniquely identifies the bill message.
Message on Bill	Displays the bill message.
Priority	Indicates the priority which determines the order in which the bill message must be printed on the trial bill.
Insert Code	Indicates whether the bill message must be sent separately along with the trial bill.

- **Characteristics** — This section lists characteristics defined for the trial bill. It contains the following columns:

Column Name	Column Description
Characteristic Type	Indicates the characteristic type.
Characteristic Value	Displays the value of the characteristic type.

In addition, this zone contains a button named **Display Trial Bill** which allows you to print a trial bill in the PDF format.

### Related Topics



For more information on...	See...
How to print a trial bill in the PDF format	<a href="#">Printing a Trial Bill in the PDF Format</a> on page 1095

## Trial Bill Segments

The **Trial Bill Segments** zone lists the segments of the trial bill. You can filter the trial bill segments using various search criteria. This zone contains the following two sections:

- **Search Criteria** — The **Search Criteria** section contains the following fields:

Field Name	Field Description	Mandatory (Yes or No)
Account ID	Used to search trial bill segments which are generated for a particular usage account.  <b>Note:</b> The <b>Search</b>  icon appears corresponding to this field. On clicking the <b>Search</b> icon, the <b>Account Search</b> window appears.	No

Field Name	Field Description	Mandatory (Yes or No)
Contract Type	Used to search trial bill segments which are generated against a particular type of contract.  <b>Note:</b> The <b>Search</b>  icon appears corresponding to this field. On clicking the <b>Search</b> icon, the <b>Contract Type Search</b> window appears.	No
Trial Bill Segment Type	Used to search for a particular type of trial bill segments. The valid values are: <ul style="list-style-type: none"> <li>• Post Processing</li> <li>• Regular</li> </ul>	No
Price Item	Used to search trial bill segments which are generated for a particular price item.  <b>Note:</b> The <b>Search</b>  icon appears corresponding to this field. On clicking the <b>Search</b> icon, the <b>Price Item Search</b> window appears.	No
Trial Bill Segment Status	Used to search trial bill segments in a particular status. The valid values are: <ul style="list-style-type: none"> <li>• Error</li> <li>• Freezable</li> </ul>	No

- **Search Results** — On clicking the **Search** button, the search results are filtered based on the specified search criteria. The **Search Results** section contains the following columns:

Column Name	Column Description
Trial Bill Segment ID	Displays the trial bill segment ID.
Status	Indicates the status of the trial bill segment. The valid values are: <ul style="list-style-type: none"> <li>• Error</li> <li>• Freezable</li> </ul>
Start Date	Displays the start date of the trial bill segment.
End Date	Displays the end date of the trial bill segment.
Calculated Amount (Pricing Currency)	Displays the trial bill segment amount in the pricing currency.
Price Item	Indicates the price item for which the trial bill segment is generated.
Pricing Parameters	Indicates the price item parameters which are used along with the price item for determining the price item pricing.
Rate Schedule	Indicates the rate schedule which is used for defining the price item pricing.
Price Assignment ID	Indicates the price item pricing which is used during calculation.

Column Name	Column Description
Billable Charge ID	Indicates the billable charge for which the trial bill segment is generated.  <b>Note:</b> It has a link. On clicking the link, the <b>Billable Charge</b> screen appears where you can view the details of the respective billable charge.
Construct ID	Indicates the construct through which the trial bill segment is generated.  <b>Note:</b> It has a link. On clicking the link, the <b>Construct</b> screen appears where you can view the details of the respective construct.

On clicking the **Broadcast**  icon corresponding to the trial bill segment, the **Trial Bill Segment Calc Lines**, **Trial Bill Segment SQ Details**, and **Trial Bill Segment Financial Details** zones appear with the details of the respective trial bill segment.

### Related Topics

For more information on...	See...
How to view the segments of a trial bill	<a href="#">Viewing the Segments of a Trial Bill</a> on page 1095

## Trial Bill Segment Calc Lines

The **Trial Bill Segment Calc Lines** zone lists the calculation lines which indicate how the system calculated the trial bill segment amount. It contains the following columns:

Column Name	Column Description
Sequence No.	Indicates the sequence in which the calculation line is created while calculating the trial bill segment amount.
Description on Bill	Displays the summarized information about the calculation line that will be printed on the trial bill.
Calculated Amount (Pricing Currency)	Displays the calculated charge amount associated with the calculation line in the pricing currency.
Calculated Amount (Invoice Currency)	Displays the calculated charge amount associated with the calculation line in the invoice currency.
Print	Indicates whether information about the calculation line will be printed on the person's trial bill. The valid values are: <ul style="list-style-type: none"> <li>• Yes</li> <li>• No</li> </ul>
Appears in Summary	Indicates whether the calculation line amount will appear in the summary of the trial bill. The valid values are: <ul style="list-style-type: none"> <li>• Yes</li> <li>• No</li> </ul>
Exchange Rate	Indicates the exchange rate which is used when the invoice currency is different from the pricing currency.
Price Component ID	Indicates the price component which is used during calculation.

Column Name	Column Description
Service Quantity Identifier	Indicates the service quantity identifier (SQI) of the service quantity which is priced on the calculation line.
Billable Service Quantity	Displays the SQI value used by the rates engine for calculation.
Base Amount	Displays the total amount derived from the cross-referenced lines that the current line then used to calculate the charge amount.
Rate Component Sequence	Indicates the sequence of the rate component on the effective rate version which is used while calculating the line.
Exempt Amount	Displays the amount of the calculated charge that the person does not have to pay due to tax exemption.
Distribution Code	Indicates the distribution code associated with the rate component.

By default, the **Trial Bill Segment Calc Lines** zone does not appear in the **Trial Bill** screen. It appears only when you click the **Broadcast**  icon corresponding to the trial bill segment in the **Trial Bill Segment** zone.

#### Related Topics

For more information on...	See...
How to view the calc lines of a trial bill segment	<a href="#">Viewing the Calc Lines of a Trial Bill Segment</a> on page 1096

### Trial Bill Segment SQ Details

The **Trial Bill Segment SQ Details** zone lists the service quantity identifiers associated with the contract against which the trial bill segment is created. It contains the following columns:

Column Name	Column Description
SQI	Indicates the service quantity identifier.
Billable Service Quantity	Displays the SQI value used by the rates engine for calculation.

By default, the **Trial Bill Segment SQ Details** zone does not appear in the **Trial Bill** screen. It appears only when you click the **Broadcast**  icon corresponding to the trial bill segment in the **Trial Bill Segment** zone.

#### Related Topics

For more information on...	See...
How to view the service quantity details of a trial bill segment	<a href="#">Viewing the SQ Details of a Trial Bill Segment</a> on page 1097

### Trial Bill Segment Financial Details

The **Trial Bill Segment Financial Details** zone lists the distribution codes which indicate the GL accounts that will be affected by the trial bill segment financial transaction. It contains the following columns:

Column Name	Column Description
Sequence No.	Indicates the sequence in which the distribution code will be considered for deriving the GL account.
Distribution Code	Indicates the distribution code associated with the rate component used for calculating the trial bill segment amount.

Column Name	Column Description
Amount	Displays the amount that will be debited or credited to the GL account.

By default, the **Trial Bill Segment Financial Details** zone does not appear in the **Trial Bill** screen. It appears only when you click the **Broadcast**  icon corresponding to the trial bill segment in the **Trial Bill Segment** zone.

### Related Topics

For more information on...	See...
How to view the financial details of a trial bill segment	<a href="#">Viewing the Financial Details of a Trial Bill Segment</a> on page 1098

## Printing a Trial Bill in the PDF Format

### Prerequisites

To print a trial bill in the PDF format, you should have:

- Oracle Documaker integrated with Oracle Revenue Management and Billing

### Procedure

To print a trial bill in the PDF format:

1. Search for the trial bill in the **Trial Bill** screen.
2. In the **Search Results** section, click the link in the **Trial Bill Information** column corresponding to the trial bill that you want to print in the PDF format.

The **Trial Bill** screen appears.

3. Click the **Display Trial Bill** button in the **Trial Bill** zone.

The trial bill is printed in the PDF format.

### Related Topics

For more information on...	See...
How to search for a trial bill	<a href="#">Searching for a Trial Bill</a> on page 1088
<b>Trial Bill</b> screen	<a href="#">Trial Bill (Used for Viewing)</a> on page 1090
<b>Trial Bill</b> zone	<a href="#">Trial Bill</a> on page 1090

## Viewing the Segments of a Trial Bill

### Procedure

To view the segments of a trial bill:

1. Search for the trial bill in the **Trial Bill** screen.
2. In the **Search Results** section, click the link in the **Trial Bill Information** column corresponding to the trial bill whose details you want to view.

The **Trial Bill** screen appears.

3. View the segments of the trial bill in the **Trial Bill Segments** zone.
4. If required, you can filter the trial bill segments using various search criteria.

**Related Topics**

For more information on...	See...
How to search for a trial bill	<a href="#">Searching for a Trial Bill</a> on page 1088
<b>Trial Bill</b> screen	<a href="#">Trial Bill (Used for Viewing)</a> on page 1090
<b>Trial Bill Segments</b> zone	<a href="#">Trial Bill Segments</a> on page 1091
How to filter the trial bill segments	<a href="#">Filtering the Trial Bill Segments</a> on page 1096

**Filtering the Trial Bill Segments****Prerequisites**

To filter the trial bill segments, you should have:

- Usage accounts, contract types, and price items defined in the application

**Procedure**

To filter the trial bill segments:

1. Search for the trial bill in the **Trial Bill** screen.
2. In the **Search Results** section, click the link in the **Trial Bill Information** column corresponding to the trial bill whose details you want to view.

The **Trial Bill** screen appears.

3. Enter the search criteria in the **Trial Bill Segments** zone.

**Note:** ORMB search engine supports wildcard search, where you can substitute the percentage (%) symbol as a stand in for any word or letter in a search criteria. You can use the ‘%’ wildcard character in all input fields except the date and ID fields. The ‘%’ wildcard character is suffixed automatically at the end of the partial search criteria. Therefore, you may or may not specify the wildcard character at the end of the partial search criteria. However, you have to prefix the wildcard character manually wherever required.

4. Click **Search**.

The search results are filtered based on the specified criteria.

**Related Topics**

For more information on...	See...
How to search for a trial bill	<a href="#">Searching for a Trial Bill</a> on page 1088
<b>Trial Bill</b> screen	<a href="#">Trial Bill (Used for Viewing)</a> on page 1090
<b>Trial Bill Segments</b> zone	<a href="#">Trial Bill Segments</a> on page 1091

**Viewing the Calc Lines of a Trial Bill Segment****Procedure**

To view the calc lines of a trial bill segment:

1. Search for the trial bill in the **Trial Bill** screen.



2. In the **Search Results** section, click the link in the **Trial Bill Information** column corresponding to the trial bill whose details you want to view.

The **Trial Bill** screen appears.

3. If required, you can filter the trial bill segments in the **Trial Bill Segments** zone.

4. In the **Search Results** section, click the **Broadcast**  icon corresponding to the trial bill segment whose details you want to view.

The **Trial Bill Segment Calc Lines**, **Trial Bill Segment SQ Details**, and **Trial Bill Segment Financial Details** zones appear.

5. View the calc lines of the trial bill segment in the **Trial Bill Segment Calc Lines** zone.

### **Related Topics**

<b>For more information on...</b>	<b>See...</b>
How to search for a trial bill	<a href="#">Searching for a Trial Bill</a> on page 1088
<b>Trial Bill</b> screen	<a href="#">Trial Bill (Used for Viewing)</a> on page 1090
How to filter the trial bill segments	<a href="#">Filtering the Trial Bill Segments</a> on page 1096
<b>Trial Bill Segment Calc Lines</b> zone	<a href="#">Trial Bill Segment Calc Lines</a> on page 1093

## **Viewing the SQ Details of a Trial Bill Segment**

### **Procedure**

To view the service quantity details of a trial bill segment:

1. Search for the trial bill in the **Trial Bill** screen.
2. In the **Search Results** section, click the link in the **Trial Bill Information** column corresponding to the trial bill whose details you want to view.

The **Trial Bill** screen appears.

3. If required, you can filter the trial bill segments in the **Trial Bill Segments** zone.

4. In the **Search Results** section, click the **Broadcast**  icon corresponding to the trial bill segment whose details you want to view.

The **Trial Bill Segment Calc Lines**, **Trial Bill Segment SQ Details**, and **Trial Bill Segment Financial Details** zones appear.

5. View the service quantity details of the trial bill segment in the **Trial Bill Segment SQ Details** zone.

### **Related Topics**

<b>For more information on...</b>	<b>See...</b>
How to search for a trial bill	<a href="#">Searching for a Trial Bill</a> on page 1088
<b>Trial Bill</b> screen	<a href="#">Trial Bill (Used for Viewing)</a> on page 1090
How to filter the trial bill segments	<a href="#">Filtering the Trial Bill Segments</a> on page 1096
<b>Trial Bill Segment SQ Details</b> zone	<a href="#">Trial Bill Segment SQ Details</a> on page 1094

## Viewing the Financial Details of a Trial Bill Segment

### Procedure

To view the financial details of a trial bill segment:

1. Search for the trial bill in the **Trial Bill** screen.
2. In the **Search Results** section, click the link in the **Trial Bill Information** column corresponding to the trial bill whose details you want to view.

The **Trial Bill** screen appears.

3. If required, you can filter the trial bill segments in the **Trial Bill Segments** zone.
4. In the **Search Results** section, click the **Broadcast**  icon corresponding to the trial bill segment whose details you want to view.

The **Trial Bill Segment Calc Lines**, **Trial Bill Segment SQ Details**, and **Trial Bill Segment Financial Details** zones appear.

5. View the financial details of the trial bill segment in the **Trial Bill Segment Financial Details** zone.

### Related Topics

For more information on...	See...
How to search for a trial bill	<a href="#">Searching for a Trial Bill</a> on page 1088
<b>Trial Bill</b> screen	<a href="#">Trial Bill (Used for Viewing)</a> on page 1090
How to filter the trial bill segments	<a href="#">Filtering the Trial Bill Segments</a> on page 1096
<b>Trial Bill Segment Financial Details</b> zone	<a href="#">Trial Bill Segment Financial Details</a> on page 1094

---

# Chapter 15

---

## GL Account Validation

---

### Topics:

- [Static GL Account Validation](#)
- [Dynamic GL Account Validation](#)

Oracle Revenue Management and Billing allows you to validate the GL account statically and dynamically. The static GL account validation means you can validate the GL account while creating or editing a distribution code. And, the dynamic GL account validation means you can validate the GL account while assigning it to trial and actual financial transactions through the batch process.

For more information about static GL account validation and dynamic GL account validation, refer to [Static GL Account Validation](#) on page 1100 and [Dynamic GL Account Validation](#) on page 1100, respectively.

## Static GL Account Validation

---

If you want to validate the GL account while creating or editing a distribution code, you need to select the **Validate GL Account** check box in the **Distribution Code** screen. If the GL account is valid, the following string appears below the check box while saving the distribution code:

“GL Account is validated on YYYY-MM-DD”

And, if the GL account is invalid, the following string appears below the check box while saving the distribution code:

“GL Account is invalid”

If you want to enable the static GL account validation feature on the **Distribution Code** screen, you need to define an algorithm of the **C1-GLVAL** or **C1-GLVAL-COB** algorithm type and attach the algorithm to the **GL Account Validation** system event in the **Algorithms** tab of the **Installation Options – Framework** screen. Both these algorithm types have one parameter named **GL Account Length**. You need to set the value of this parameter while creating the algorithm using the **C1-GLVAL** or **C1-GLVAL-COB** algorithm type. If you attach an algorithm of the **C1-GLVAL** algorithm type, the system checks whether the length of GL account is greater than or equal to the value defined in the **GL Account Length** parameter. If the length is greater than or equal to the specified length, the GL account is considered as valid. And, if the length is less than the specified length, the GL account is considered as invalid.

And, if you attach an algorithm of the **C1-GLVAL-COB** algorithm type, the system checks whether the length of GL account is equal to the value defined in the **GL Account Length** parameter. If the length is equal to the specified length, the GL account is considered as valid. And, if the length is less than or greater than the specified length, the GL account is considered as invalid.

## Dynamic GL Account Validation

---

If you want to validate GL account while assigning it to trial and actual financial transactions, you need to set the **Validate GL Account** parameter to **Y** while executing the batch. If the GL account is valid, the date when the GL account is validated is added in the **GLA\_VAL\_DT** column of the **CI\_TRL\_FT\_GL** or **CI\_FT\_GL** table, respectively, depending on whether the GL account is assigned to a trial or actual financial transaction.

If you want to enable the dynamic GL account validation feature in the **C1-GLASN** or **GLASSGN2** batch, you need to define an algorithm of the **C1-GLVAL** or **C1-GLVAL-COB** algorithm type and attach the algorithm to either of the following:

- The **GL Account Validation** algorithm entity in the **Algorithms** tab of the **Division** screen
- The **GL Account Validation** system event in the **Algorithms** tab of the **Installation Options – Framework** screen

If the GL account validation algorithm is defined at both these algorithm spots, the algorithm defined at the division level always takes precedence over the algorithm defined in the installation options during dynamic GL account validation.

---

# Chapter 16

---

## Upload Validated Adjustment Data

---

### Topics:

- [Prerequisites](#)
- [CSV File Format](#)
- [Adjustment Upload Request \(Without Approval\) Status Transition](#)
- [Adjustment Upload Request \(With Approval\) Status Transition](#)
- [Algorithms Used in C1-ADJUPLD](#)
- [Upload Request Type](#)
- [Adjustment Upload Request \(Used for Searching\)](#)
- [Adjustment Upload Request \(Used for Viewing\)](#)

Oracle Revenue Management and Billing until now provided you with an ability to upload adjustment data received from an external source system and create adjustments using the **C1-ADUP1** and **C1-ADUP2** batches. However, there was no user interface available through which you can upload an adjustment data file and create adjustments from the adjustment records. Now, the system provides a user interface which helps you to upload an adjustment data file.

You can upload an adjustment data file in the CSV format. You need to ensure that the CSV file is in the required format; otherwise the file will not be uploaded in the system. At present, the system supports only the CSV file format. For more information about the CSV file format, see [CSV File Format](#) on page 1103.

While uploading an adjustment data file, you need to specify the upload request type using which you want to upload the adjustment data file. It is the upload request type which helps the system to determine:

- Whether adjustments must be created in the real time (i.e. immediately) or in the deferred mode (i.e. in the background)
- Whether the size of the adjustment data file exceeds the maximum file size defined in the upload request type
- Whether the adjustment data file must be approved by the approver before creating adjustments

All records are validated before uploading an adjustment data file. During the validation process, the system and custom validations (if any) are executed. If there is any invalid record, the system does not allow you to upload the adjustment data file. The system indicates the reason why the adjustment record could not pass through the validation process. You need to first correct the adjustment record in the CSV file and then upload the adjustment data file.

An upload request of the specified upload request type is created when an adjustment data file is successfully uploaded in the system. You can track an adjustment data file through an upload request. During the adjustment upload process, an adjustment upload request goes through various statuses in its lifecycle. For more information about the adjustment upload request statuses, see [Adjustment Upload Request \(Without Approval\) Status Transition](#) on page 1104 and [Adjustment Upload Request \(With Approval\) Status Transition](#) on page 1105.

Note that the lifecycle of an adjustment upload request is driven by the business object using which the adjustment upload request is created. An adjustment upload request business object named **C1-ADJUPLD** is shipped with the product. The adjustment upload feature explained in this section is documented based on the lifecycle and logic defined in the **C1-ADJUPLD** business object.

If required, the implementation team can create a custom adjustment upload request business object.

Once the adjustment upload request is created, you can perform various tasks, such as:

- Track the status of an adjustment upload request
- View the details of an adjustment upload request
- View all records of an adjustment data file
- Cancel an adjustment data file
- Create adjustments for an adjustment data file
- Submit the adjustment data file for approval
- Approve or reject an adjustment data file based on the observations

## Prerequisites

---

To setup the adjustment upload process, you need to do the following:

- Define the required upload request types in the system
- Create a defer algorithm using the **C1-UPLDEFEVL** algorithm type
- Create an algorithm using the **C1-MTCIALG** algorithm type if you want to create adjustments using the Contract match type
- Create an algorithm using the **C1-MTCTALG** algorithm type if you want to create adjustments using the Contract Type match type
- Define the required characteristic types where the characteristic entity is set to Upload Request Type
- Define cancellation and rejection reasons for the **C1-ADJUPLD** business object
- Assign the **C1-ADJUP** To Do type to a To Do role whose users must receive To Do entries generated while submitting an upload request (i.e. an adjustment data file) for approval
- Set the batch control type of the **Upload Request Periodic Monitor (C1-UPLRQ)** batch to **Timed** and define the following attributes:
  - Time Interval
  - Timer Active
  - User ID
  - Batch Language
  - Email Address

## CSV File Format

---

Before uploading an adjustment data file, you need to ensure that the CSV file contains the following columns:

Column Name	Description	Mandatory (Yes or No)
Account Identifier Type	Used to specify the account identifier type.	Yes (Conditional) <b>Note:</b> This data is required when the match type is Contract Type and account ID is not specified.
Account Identifier	Used to specify the account identifier.	Yes (Conditional) <b>Note:</b> This data is required when the match type is Contract Type and account ID is not specified.
Account ID	Used to indicate the account for which the adjustment must be created.	Yes (Conditional) <b>Note:</b> This data is required when the match type is Contract Type and the account identifier type and account identifier are not specified.

Column Name	Description	Mandatory (Yes or No)
Match Type	Used to indicate the match type using which the adjustment must be created.	Yes
Match Value	Used to indicate the entity (such as contract, contract type, and so on) against which the adjustment must be created.	Yes
Adjustment Type	Used to indicate the adjustment type using which the adjustment must be created.  <b>Note:</b> The adjustment type must be included in the adjustment type profile which is attached to the contract type.	Yes
Adjustment Amount	Used to specify the adjustment amount.  <b>Note:</b> The adjustment amount precision must match the precision (decimal positions) defined for the currency.	Yes
Currency Code	Used to indicate the currency in which the adjustment must be created.	Yes
Comments	Used to specify additional information about the adjustment.	No
Bill ID	Used to indicate the bill on which the adjustment must be created.	No
Arrears Date	Used to specify the date from when the amount is outstanding on the bill.	No
Char Type 1, Char Type 2, ....., Char Type 5	Used to indicate the characteristic that must be defined for the adjustment.	Yes (Conditional)  <b>Note:</b> This data is required if the characteristic value is specified.
Char Value 1, Char Value 2, ....., Char Value 5	Used to specify the value for the characteristic type.	Yes (Conditional)  <b>Note:</b> This data is required if the characteristic type is specified.

**Note:** If an adjustment data file contains column names other than those mentioned in the above table, the system will not upload the adjustment data file.

## Adjustment Upload Request (Without Approval) Status Transition

The following figure graphically indicates how an adjustment upload request moves from one status to another when approval workflow is off:



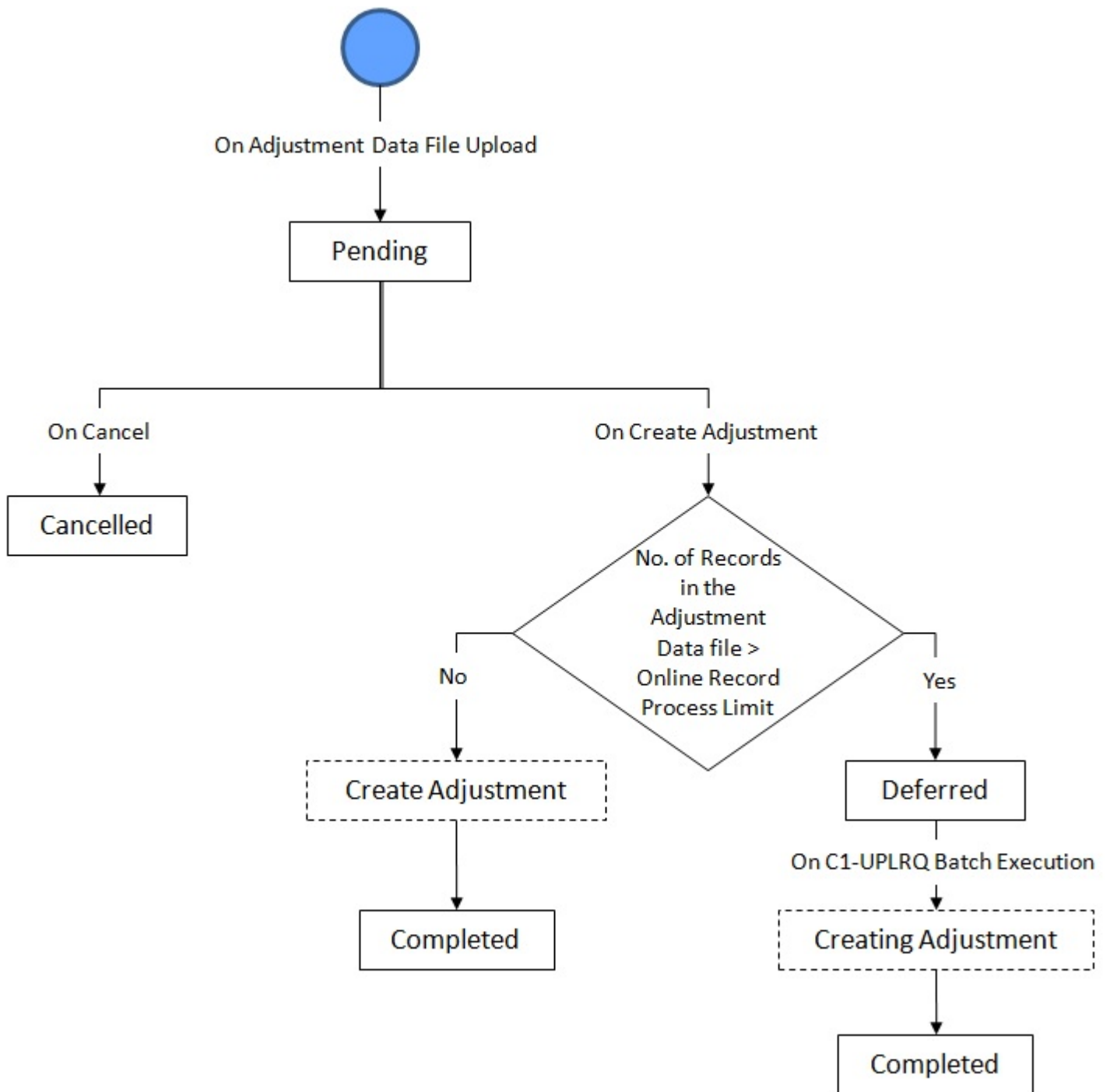

## Adjustment Upload Request (With Approval) Status Transition

The following figure graphically indicates how an adjustment upload request moves from one status to another when approval workflow is on:

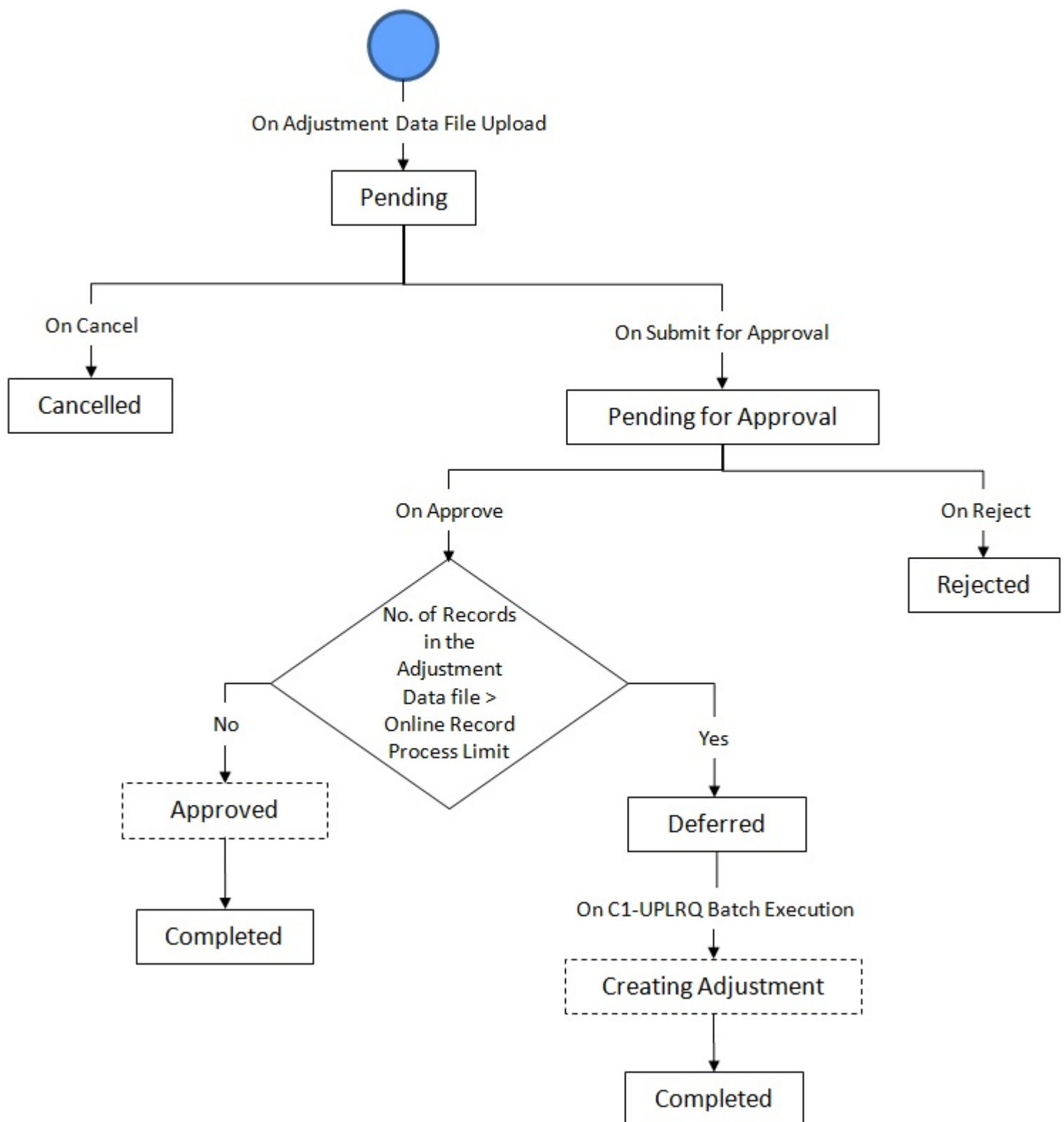

## Algorithms Used in C1-ADJUPLD

The following table lists the algorithms which are attached to the **C1-ADJUPLD** business object:

System Event	Algorithm	Algorithm Type	Description
Information	C1-FLREQ-INF	C1-FLREQ-INF	<p>This algorithm formats the upload request information that appears throughout the system for the BO. The algorithm formats the information as follows: Upload Request type description, Status description, ID. This algorithm generates the upload request information string which appears throughout the application. This algorithm concatenates the following fields:</p> <ul style="list-style-type: none"> <li>• Upload Request Type Description</li> <li>• Upload Request Description</li> <li>• Upload Request ID</li> </ul>
Validation	C1-ADVALREQ	C1-ADVALREQ	<p>This algorithm will be called from a business service and is responsible for validating the uploaded CSV file and identify if any records are invalid. The validations to be performed are mentioned below:</p> <ol style="list-style-type: none"> <li>1. Mandatory column data checks</li> <li>2. Check for valid values for account, match type, match value, adjustment type, adjustment characteristics type, currency and amount.</li> <li>3. This algorithm will also call the match type algorithm linked to the request type to derive and validate the value for contract ID. This algorithm validates the uploaded CSV file and identifies invalid records, if any. The validations performed are as follows:</li> </ol> <ul style="list-style-type: none"> <li>• Validating mandatory column data</li> <li>• Validating values for account, match type, match value, adjustment type, adjustment characteristics type, currency and amount.</li> <li>• Invoke the match type algorithm linked to the request type to derive and validate the value for contract ID.</li> </ul>

The following table lists the algorithms which are used in the lifecycle of the **C1-ADJUPLD** business object:

Status	System Event	Algorithm	Algorithm Type	Description
Draft	-	-	-	-
Cancelled	-	-	-	-

Status	System Event	Algorithm	Algorithm Type	Description
Create Adjustment	Enter	C1-ADJUPLDEF	C1-ADJUPLDEF	This algorithm will evaluate if request processing should be done in real time or deferred for offline processing. This will be invoked by the Enter Status algorithm when the Request object enters 'CREATE' or 'APPROVED' status. This algorithm evaluates and creates adjustment. It evaluates, if request should be processed in real time or deferred for offline processing. This algorithm is triggered by the <b>Enter</b> status algorithm when the request object is changed to <b>Create</b> or <b>Approved</b> status.
Deferred	Monitor	C1-ADJ-MNTR	C1-ADJ-MNTR	This algorithm will be invoked from the Upload Request Monitor batch. This will be responsible for BO transition from 'Deferred' to 'Creating' status. This algorithm is triggered from the <b>Upload Request Monitor</b> batch. This algorithm transitions the business object status from <b>Deferred</b> to <b>Creating</b> .
Pending for Approval	Enter	C1-ADJUPAPVL	C1-ADJUPAPVL	This algorithm will be responsible of creating To Do for the approver to approve or reject the uploaded file data. To Do will be created using the To Do Type linked to the request type to the approver(s) who are associated with the To Do Role linked to the request type. This will be invoked by the Enter Status algorithm when the Request object enters 'SUBMITTED - Pending For Approver' status. This algorithm creates the To Do using the To Do Type for the approver to approve or reject the uploaded file data. This To Do Type is linked to the request type to the approver(s) associated with the To Do Role linked to the request type. This algorithm is triggered by the <b>Enter</b> status algorithm when the request object enters <b>Submitted - Pending For Approver</b> status.

Status	System Event	Algorithm	Algorithm Type	Description
Approved	Enter	C1-ADJUPLDEF	C1-ADJUPLDEF	This algorithm will evaluate if request processing should be done in real time or deferred for offline processing. This will be invoked by the Enter Status algorithm when the Request object enters 'CREATE' or 'APPROVED' status. This algorithm evaluates if request should be processed in real time or deferred for offline processing. This algorithm is triggered by the <b>Enter</b> status algorithm when the request object is changed to <b>Create</b> or <b>Approved</b> status.
Rejected	-	-	-	-
Completed	-	-	-	-
Creating Adjustment	Enter	C1-ADJCRTION	C1-ADJCRTION	This algorithm is responsible for creating Adjustment for the uploaded file. The adjustment ID will be updated back in the request table to link the request with the adjustments. This algorithm creates an adjustment for the uploaded file. In addition, the adjustment ID is stamped on the adjustment and on the corresponding financial transaction.

## Upload Request Type

Oracle Revenue Management and Billing allows you to define an upload request type using which you can upload a file. An upload request of the specified upload request type is created on uploading the file. It is the upload request type which helps the system to understand how to process the file. If you upload a file which exceeds the maximum file size, the system will not allow you to upload the file.

The **Adjustment Upload Request Type (C1-AdjRequestType)** business object is used for the maintenance of upload request types for uploading CSV data. Configurations like upload file size, approval workflow can be configured using this object. If you are going to upload adjustment data files using an upload request type, you need to specify the match types (using which the adjustments must be created) in the upload request type. At present, the following two match types are shipped with the product:

- Contract
- Contract Type

You can also define custom match types, if required. You must use the **ADJ\_MATCH\_TYPE** lookup field to add a new match type. You need to attach an algorithm to each match type to determine the contract against which the adjustment must be created. At present, the following algorithm types and sample algorithms are shipped with the product:

Match Type	Algorithm Type	Sample Algorithm	Algorithm Description
Contract	C1-MTCIALG	C1-MTCIALG	This algorithm fetches contract ID for each adjustment record where the match type is set to <b>Contract (CONT)</b> .

Match Type	Algorithm Type	Sample Algorithm	Algorithm Description
Contract Type	C1-MTCTALG	C1-MTCTALG	This algorithm fetches contract ID based on the contract type and account ID for each adjustment record where the match type is set to <b>Contract Type (CNTY)</b> . If there are multiple active contracts of the specified contract type on the account, the contract ID with the latest start date will be fetched.

The **Upload Request Type (C1-UplRequestType)** business object will be used for the maintenance of upload request types for uploading CSV data. Configurations like upload file size, approval workflow can be configured using this object. The system enables you to upload data for the following using the **Upload Request** feature:

- Billable Charge (Adhoc and Regular)
- Hold Request
- Refund Request
- Write Off Request
- Policy Reinstatement
- Bill Group Sort ID
- Derivation and Pricing Parameters for a Bill Group and Sort ID Combination

It also enables you to update the following information:

- Contract rider of a contract
- Bill cycle of an account

It is the upload request type which helps the system to determine:

- Whether the file must be approved by the approver before creating or updating the entities
- Which business object must be used for creating the upload request
- Which business object must be used for creating or updating entities through an upload request
- Which foreign key reference must be used for generating information string for the entity
- A set of fields using which you can search records uploaded through an upload request

You can also define custom algorithm types and algorithms, if required. The **Upload Request Type** screen allows you to define, edit, copy, and delete an upload request type. This screen consists of the following zones:



- [Upload Request Type List](#) on page 1110
- [Upload Request Type](#) on page 1111

**Parent topic:** [Upload Request](#) on page 1573

## Upload Request Type List

The **Upload Request Type List** zone lists upload request types that are already defined in the system. It contains the following columns:

Column Name	Column Description
Upload Request Type	Displays the upload request type.
Description	Displays the description of the upload request type.
Edit	On clicking the <b>Edit</b>  icon, the <b>Upload Request Type</b> screen appears where you can edit the details of the upload request type.

Column Name	Column Description
Duplicate	On clicking the <b>Duplicate</b> (  ) icon, the <b>Upload Request Type</b> screen appears where you can define an upload request type using an existing upload request type.
Delete	On clicking the <b>Delete</b> (  ) icon, you can delete the upload request type.  <b>Note:</b> You can delete an upload request type only when you have not uploaded a file (i.e. created an upload request) using the upload request type.
Mapping	On clicking the <b>Mapping</b> (  ) icon, the mapping screen appears where you can map the columns of CSV file with the upload request type.

On clicking the **Broadcast** () icon corresponding to an upload request type, the **Upload Request Type** zone appears with the details of the respective upload request type.

### Related Topics

For more information on...	See...
How to define an upload request type	<a href="#">Defining an Upload Request Type</a> on page 1114
How to define characteristics for an upload request type	<a href="#">Defining Characteristics for an Upload Request Type</a> on page 1120
How to edit an upload request type	<a href="#">Editing an Upload Request Type</a> on page 1121
How to copy an upload request type	<a href="#">Copying an Upload Request Type</a> on page 1125
How to delete an upload request type	<a href="#">Deleting an Upload Request Type</a> on page 1130
How to map an upload request type	<a href="#">Mapping an Upload Request Type</a> on page 1129
How to view the details of an upload request type	<a href="#">Viewing the Upload Request Type Details</a> on page 1131

## Upload Request Type

The **Upload Request Type** zone displays the details of the upload request type. This zone contains the following sections:

- **Main** – This section provides basic information about the upload request type. It contains the following fields:

Field Name	Field Description
Upload Request Type	Displays the upload request type.
Upload Request Business Object	Indicates the business object that will be used to create the upload request. In addition, a context menu appears corresponding to this field which helps in navigating to other screens in the application.  <b>Note:</b> It has a link. On clicking the link, the <b>Business Object</b> screen appears where you can view the details of the respective business object.
Description	Displays the description of the upload request type.
Detailed Description	Displays additional information about the upload request type.

Field Name	Field Description
Status	<p>Indicates the status of the upload request type. The valid values are:</p> <ul style="list-style-type: none"> <li>• Active</li> <li>• Inactive</li> </ul>
File Size (KB)	<p>Displays the maximum size of file (in kilobytes) that you can upload using the upload request type. If you upload a file which exceeds the maximum file size, the system will not allow you to upload the file.</p> <div style="border: 1px solid black; padding: 5px;"> <p><b>Note:</b> This field appears only when you create upload request type using <b>Adjustment Upload Request Type</b> business object.</p> </div>
Defer Algorithm	<p>Indicates the algorithm that will be triggered when you create entities (for example, adjustments) or approve the uploaded file (for example, adjustment data file). This algorithm checks whether the number of records in the uploaded file exceeds the online record process limit. If the number of records in the uploaded file does not exceed the online record process limit, the system creates the entities in the real time (i.e. immediately). However, if the number of records in the uploaded file exceeds the online record process limit, the system creates the entities (for example, adjustments) in the real time (i.e. immediately). However, if the number of records in the uploaded file exceeds the online record process limit, the system creates the entities (for example, adjustments) in the deferred mode.</p> <div style="border: 1px solid black; padding: 5px;"> <p><b>Note:</b>  This field appears only when you create upload request type using <b>Adjustment Upload Request Type</b> business object.  It has a link. On clicking the link, the <b>Algorithm</b> screen appears where you can view the details of the respective algorithm.  In <b>Upload Request Type</b>, online and deferred mode is used for processing the file if approval is not required. The defer algorithm is invoked if the number of records to be processed on the respective business object is more than the count specified on the algorithm then the status for number of records is changed from <b>Validated</b> to <b>Deferred Processing</b> else the status is changed to <b>Processed</b>.</p> </div>
Approval Required	<p>Indicates whether approval is required for a file which is uploaded using the upload request type.</p>
Approval To Do Type	<p>Indicates that the To Do entry of the specified To Do type must be created when you submit the upload request for approval.</p> <div style="border: 1px solid black; padding: 5px;"> <p><b>Note:</b>  This field appears only when the <b>Approval Required</b> check box is selected.  It has a link. On clicking the link, the <b>To Do Type</b> screen appears with the details of the respective To Do type.</p> </div>



Field Name	Field Description
Approval To Do Role	<p>Indicates that users with the specified To Do role can only approve or reject the upload request submitted for approval.</p> <p><b>Note:</b> This field appears only when the <b>Approval Required</b> check box is selected. On selecting the <b>To Do Type</b>, the <b>To Do Roles</b> configured on the <b>To Do Type</b> is populated. It has a link. On clicking the link, the <b>To Do Role</b> screen appears with the details of the respective To Do role.</p>
FK Reference	<p>Indicates the foreign key reference which specifies the created upload request type.</p> <p><b>Note:</b> This field appears only when you create upload request type using <b>Upload Request Type</b> business object. It has a link. On clicking the link, the <b>Foreign Key Reference</b> screen appears with the details of the respective foreign key.</p>

In addition, this section has the following columns:

Column Name	Column Description
Match Type	<p>Indicates the match type using which the adjustments must be created when you upload a file using the upload request type. The valid values are:</p> <ul style="list-style-type: none"> <li>Contract</li> <li>Contract Type</li> </ul> <p><b>Note:</b> The <b>Match Type</b> column is displayed for <b>Adjustment Upload Request</b> Business Object.</p>
Algorithm	<p>Indicates the algorithm that will be triggered when you upload an adjustment data file. This algorithm determines the contract against which the adjustment must be created.</p> <p><b>Note:</b> It has a link. On clicking the link, the <b>Algorithm</b> screen appears with the details of the respective algorithm. The <b>Algorithm</b> column is displayed for <b>Adjustment Upload Request</b> Business Object.</p>

- **Characteristics** – This section lists the characteristics defined for the upload request type. It contains the following columns:

Column Name	Column Description
Characteristic Type	Indicates the characteristic type.
Characteristic Value	Displays the value of the characteristic type.

- **Record Actions** – This section contains the following buttons:

Button Name	Button Description
Edit	Used to edit the details of the upload request type.
Delete	Used to delete the upload request type. <b>Note:</b> You can delete an upload request type only when you have not uploaded a file (i.e. created an upload request) using the upload request type.
Duplicate	Used to create a new upload request type using an existing upload request type.

- **Record Information** – This section contains the following fields:

Field Name	Field Description
Business Object	Indicates the business object using which the upload request type is created. In addition, a context menu appears corresponding to this field which helps in navigating to other screens in the application. <b>Note:</b> It has a link. On clicking the link, the <b>Business Object</b> screen appears where you can view the details of the respective business object.

By default, the **Upload Request Type** zone does not appear in the **Upload Request Type** screen. It appears only when you click the **Broadcast**  icon corresponding to an upload request type in the **Upload Request Type List** zone.

### Related Topics

For more information on...	See...
How to define an upload request type	<a href="#">Defining an Upload Request Type</a> on page 1114
How to define characteristics for an upload request type	<a href="#">Defining Characteristics for an Upload Request Type</a> on page 1120
How to edit an upload request type	<a href="#">Editing an Upload Request Type</a> on page 1121
How to copy an upload request type	<a href="#">Copying an Upload Request Type</a> on page 1125
How to delete an upload request type	<a href="#">Deleting an Upload Request Type</a> on page 1130
How to map an upload request type	<a href="#">Mapping an Upload Request Type</a> on page 1129
How to view the details of an upload request type	<a href="#">Viewing the Upload Request Type Details</a> on page 1131

## Defining an Upload Request Type

### Prerequisites

To define an upload request type, you should have:

- Upload request business objects defined in the application
- Defer algorithm for adjustment is defined using the **C1-UPLDEFEVL** algorithm type
- Defer algorithm for upload is defined using the **C1-DEFERUPLD** algorithm type
- Algorithm defined using the **C1-MTCIALG** algorithm type when you want to create adjustment using the **Contract** match type
- **C1-ADJUP** To Do type assigned to a To Do role whose users must receive To Do while submitting an adjustment upload request for approval

- **C1-BCUUR** To Do type assigned to a To Do role whose users must receive To Do while submitting a bill cycle update upload request for approval
- **C1-CRUUR** To Do type assigned to a To Do role whose users must receive To Do while submitting a contract rider update upload request for approval
- **C1-HLDUR** To Do type assigned to a To Do role whose users must receive To Do while submitting a hold upload request for approval
- **C1-REFUR** To Do type assigned to a To Do role whose users must receive To Do while submitting a refund upload request for approval
- **C1-WOUR** To Do type assigned to a To Do role whose users must receive To Do while submitting a write off upload request for approval
- **C1-BCUR** To Do type assigned to a To Do role whose users must receive To Do while submitting a billable charge upload request for approval
- **C1-RPUR** To Do type assigned to a To Do role whose users must receive To Do while submitting a reinstatement upload request for approval
- **C1-BGSRT** To Do type assigned to a To Do role whose users must receive To Do while submitting a bill group sorting upload request for approval
- **C1-BGDVP** To Do type assigned to a To Do role whose users must receive To Do while submitting a bill group derivation and pricing parameters upload request for approval

### **Procedure**

To define an upload request type:

1. Click the **Admin** link in the **Application** toolbar.  
A list appears.
2. From the **Admin** menu, select **U** and then click **Upload Request Type**.  
A sub-menu appears.
3. Click the **Add** option from the **Upload Request Type** sub-menu.

The **Select Business Object** screen appears. It contains the following field:

Field Name	Field Description	Mandatory (Yes or No)
Upload Request Type Business Object	Used to indicate the business object that you want to use to create the upload request type.	Yes

**Tip:** Alternatively, you can access the **Select Business Object** screen by clicking the **Add** button in the **Page Title** area of the **Upload Request Type** screen.

**Note:** The **Select Business Object** screen appears only when there are multiple upload request type business objects defined in the application. If there is only one upload request type business object defined in the application, the **Upload Request Type** screen appears.

4. Select the required upload request type business object from the respective field.
5. Click **OK**.



The **Upload Request Type** screen appears. It contains the following sections:

- **Main** – Used to specify basic details about the upload request type.
- **Characteristics** – Used to define characteristics for the upload request type.

The **Main** section contains the following fields:

Field Name	Field Description	Mandatory (Yes or No)
Upload Request Type	Used to specify the upload request type.	Yes
Upload Request Type Business Object	Indicates the upload request type business object used while defining the upload request type.	Not applicable
Upload Request Business Object	Used to indicate the business object that you want to use while creating the upload request.	Yes
Description	Used to specify the description for the upload request type.	Yes
Detailed Description	Used to specify additional information about the upload request type.	No
Status	Used to indicate the status of the upload request type. The valid values are: <ul style="list-style-type: none"> <li>• Active</li> <li>• Inactive</li> </ul>	Yes
File Size (KB)	Used to specify the maximum size of file (in kilobytes) that you can upload using the upload request type. If you upload a file which exceeds the maximum file size, the system will not allow you to upload the file. <div style="border: 1px solid black; padding: 5px; margin-top: 10px;"> <p><b>Note:</b> This field appears when <b>Adjustment Upload Request Type</b> business object is selected.</p> </div>	Yes

Field Name	Field Description	Mandatory (Yes or No)
Defer Algorithm	<p>Used to attach an algorithm that will be triggered when you create entities (for example, adjustments) or approve the uploaded file (for example, adjustment data file). This algorithm checks whether the number of records in the uploaded file exceeds the online record process limit (defined in the Defer algorithm). If the number of records in the uploaded file does not exceed the online record process limit, the system creates the entities (for example, adjustments) in the real time (i.e. immediately). However, if the number of records in the uploaded file exceeds the online record process limit, the system creates the entities (for example, adjustments) in the deferred mode.</p> <div style="border: 1px solid black; padding: 5px;"> <p><b>Note:</b></p> <p>Deferred mode means in the background when the <b>Upload Request Periodic Monitor (C1-UPLRQ)</b> batch is invoked. You can configure the <b>Upload Request Periodic Monitor (C1-UPLRQ)</b> batch such that it is executed at regular intervals. When the <b>Upload Request Periodic Monitor (C1-UPLRQ)</b> batch is invoked, the system checks whether there are any upload requests in the <b>Deferred</b> status. If there is an upload request in the <b>Deferred</b> status, the system creates the entities (for example, adjustments).</p> <p>This field appears when <b>Adjustment Upload Request Type</b> business object is selected.</p> <p>In <b>Upload Request Type</b>, online and deferred mode is used for processing the file if approval is not required. The defer algorithm is invoked if the number of records to be processed on the respective business object is more than the count specified on the algorithm then the status for number of records is changed from <b>Validated</b> to <b>Deferred Processing</b> else the status is changed to <b>Processed</b>.</p> </div> <div style="border: 1px solid black; padding: 5px; margin-top: 5px;"> <p><b>Note:</b> The <b>Search</b>  icon appears corresponding to this field. On clicking the <b>Search</b> icon, the <b>Algorithm Search</b> window appears.</p> </div>	Yes

Field Name	Field Description	Mandatory (Yes or No)																						
Entity Business Object	<p>Used to indicate for creating Business Object of the entity using the upload request type.</p> <div style="border: 1px solid black; padding: 5px;"> <p><b>Note:</b></p> <p>The <b>Search</b>  icon appears corresponding to this field. On clicking the <b>Search</b> icon, the <b>Business Object Search</b> window appears.</p> <p>This field appears when <b>Upload Request Type</b> business object is selected.</p> </div>	No																						
Approval Required	Used to indicate whether approval is required for a file which is uploaded using the upload request type.	No																						
Approval To Do Type	<p>Used to indicate that To Do entry of the specified To Do type must be created when you submit the upload request for approval.</p> <div style="border: 1px solid black; padding: 5px;"> <p><b>Note:</b></p> <p>The <b>Search</b>  icon appears corresponding to this field. On clicking the <b>Search</b> icon, the <b>To Do Type Search</b> window appears.</p> <p>The following table lists the To Do type using which the To Do must be generated for the different upload requests:</p> <table border="1" data-bbox="667 1108 1135 1816"> <thead> <tr> <th>Upload Request</th> <th>To Do Type</th> </tr> </thead> <tbody> <tr> <td>Adjustment</td> <td>C1-ADJUP</td> </tr> <tr> <td>Bill Cycle Update</td> <td>C1-BCUUR</td> </tr> <tr> <td>Billable Charge</td> <td>C1-BCUR</td> </tr> <tr> <td>Contract Rider Update</td> <td>C1-CRUUR</td> </tr> <tr> <td>Hold Request</td> <td>C1-HLDUR</td> </tr> <tr> <td>Refund Request</td> <td>C1-REFUR</td> </tr> <tr> <td>Write Off Request</td> <td>C1-WOUR</td> </tr> <tr> <td>Policy Reinstatement</td> <td>C1-RPUR</td> </tr> <tr> <td>Bill Group Sorting</td> <td>C1-BGSRT</td> </tr> <tr> <td>Bill Group Derivation and Pricing Parameters</td> <td>C1-BGDVP</td> </tr> </tbody> </table> </div>	Upload Request	To Do Type	Adjustment	C1-ADJUP	Bill Cycle Update	C1-BCUUR	Billable Charge	C1-BCUR	Contract Rider Update	C1-CRUUR	Hold Request	C1-HLDUR	Refund Request	C1-REFUR	Write Off Request	C1-WOUR	Policy Reinstatement	C1-RPUR	Bill Group Sorting	C1-BGSRT	Bill Group Derivation and Pricing Parameters	C1-BGDVP	<p>Yes (Conditional)</p> <div style="border: 1px solid black; padding: 5px;"> <p><b>Note:</b> This field is required when the <b>Approval Required</b> check box is selected.</p> </div>
Upload Request	To Do Type																							
Adjustment	C1-ADJUP																							
Bill Cycle Update	C1-BCUUR																							
Billable Charge	C1-BCUR																							
Contract Rider Update	C1-CRUUR																							
Hold Request	C1-HLDUR																							
Refund Request	C1-REFUR																							
Write Off Request	C1-WOUR																							
Policy Reinstatement	C1-RPUR																							
Bill Group Sorting	C1-BGSRT																							
Bill Group Derivation and Pricing Parameters	C1-BGDVP																							

Field Name	Field Description	Mandatory (Yes or No)
Approval To Do Role	Used to indicate that users with the specified To Do role can only approve the upload request submitted for approval.	Yes (Conditional) <b>Note:</b> This field is required when the <b>Approval Required</b> check box is selected.
FK Reference	Used to indicate the FK Reference code to display the entity information. <b>Note:</b> The <b>Search</b> (  ) icon appears corresponding to this field. On clicking the <b>Search</b> icon, the <b>Foreign Key Search</b> window appears. This field appears when <b>Upload Request Type</b> business object is selected.	No

In addition, this section contains the following fields in the grid:



**Note:** This field appears when **Adjustment Upload Request Type** business object is selected.

Field Name	Field Description	Mandatory (Yes or No)
Match Type	Used to indicate the match type using which you want to create adjustments when you upload a file using the upload request type. The valid values are: <ul style="list-style-type: none"> <li>Contract</li> <li>Contract Type</li> </ul>	Yes (Conditional) <b>Note:</b> This field is required when you select the <b>Adjustment Upload Request</b> option from the <b>Upload Request Business Object</b> list.
Algorithm	Used to attach an algorithm that will be triggered when you upload an adjustment data file. This algorithm determines the contract against which the adjustment must be created. <b>Note:</b> The <b>Search</b> (  ) icon appears corresponding to this field. On clicking the <b>Search</b> icon, the <b>Algorithm Search</b> window appears.	Yes (Conditional) <b>Note:</b> This field is required when you select the match type from the respective field.

6. Enter the required details.

**Note:**

You can search for an algorithm by clicking the **Search** () icon corresponding to the respective field.

If you want to associate more than one match type with the upload request type, click the **Add** () icon and then specify the details. However, if you want to remove a match type from the upload request type, click the **Delete** () icon corresponding to the match type.

7. Define characteristics for the upload request type, if required.

8. Click **Save**.

The upload request type is defined.

**Related Topics**

For more information on...	See...
<b>Upload Request Type</b> screen	<a href="#">Upload Request Type</a> on page 1109
<b>Upload Request Type List</b> zone	<a href="#">Upload Request Type List</a> on page 1110
How to define characteristics for an upload request type	<a href="#">Defining Characteristics for an Upload Request Type</a> on page 1120

**Defining Characteristics for an Upload Request Type****Prerequisites**

To define characteristics for an upload request type, you should have:

- Characteristic types defined in the application (where the characteristic entity is set to Upload Request Type)

**Procedure**

To define characteristics for an upload request type:

1. Ensure that the **Characteristics** section is expanded when you are defining, editing, or copying an upload request type.

The **Characteristics** section contains the following fields:

Field Name	Field Description	Mandatory (Yes or No)
Characteristic Type	Used to indicate the characteristic type. <b>Note:</b> The list includes only those characteristic types where the characteristic entity is set to Upload Request Type.	Yes (Conditional) <b>Note:</b> This field is required when you are defining a characteristic for the upload request type.
Characteristic Value	Used to specify the value for the characteristic type. <b>Note:</b> On specifying the value for a predefined characteristic type, the description of the characteristic value appears corresponding to the <b>Characteristic Value</b> field.	Yes (Conditional) <b>Note:</b> This field is required when you are defining a characteristic for the upload request type.

2. Enter the required details.

**Note:** If you select a predefined characteristic type, the **Search**  icon appears corresponding to the **Characteristic Value** field. On clicking the **Search** icon, you can search for a predefined characteristic value.

3. If you want to define more than one characteristic for the upload request type, click the **Add**  icon and then repeat step 2.



**Note:** However, if you want to remove a characteristic from the upload request type, click the **Delete** () icon corresponding to the characteristic.

### Related Topics

For more information on...	See...
How to define an upload request type	<a href="#">Defining an Upload Request Type</a> on page 1114
How to edit an upload request type	<a href="#">Editing an Upload Request Type</a> on page 1121
How to copy an upload request type	<a href="#">Copying an Upload Request Type</a> on page 1125

## Editing an Upload Request Type

### Prerequisites

To edit an upload request type, you should have:

- Upload request business objects defined in the application
- Defer algorithm for adjustment is defined using the **C1-UPLDEFEVL** algorithm type
- Defer algorithm for upload is defined using the **C1-DEFERUPLD** algorithm type
- Algorithm defined using the **C1-MTCIALG** algorithm type when you want to create adjustment using the Contract match type
- Algorithm defined using the **C1-MTCTALG** algorithm type when you want to create adjustment using the Contract Type match type
- **C1-ADJUP** To Do type assigned to a To Do role whose users must receive To Do entries generated while submitting an adjustment upload request for approval
- **C1-UPLAPPENT** To Do type assigned to a To Do role whose users must receive To Do generated while submitting an upload request for approval

### Procedure

To edit an upload request type:

1. Click the **Admin** link in the **Application** toolbar.  
A list appears.
2. From the **Admin** menu, select **U** and then click **Upload Request Type**.  
A sub-menu appears.
3. In the **Upload Request Type List** zone, click the **Edit** () icon in the **Edit** column corresponding to the upload request type whose details you want to edit.



The **Upload Request Type** screen appears. It contains the following sections:

- **Main** – Used to specify basic details about the upload request type.
- **Characteristics** – Used to define characteristics for the upload request type.

The **Main** section contains the following fields:

Field Name	Field Description	Mandatory (Yes or No)
Upload Request Type	Displays the upload request type.	Not applicable
Upload Request Type Business Object	Indicates the upload request type business object used while defining the upload request type.	Not applicable

Field Name	Field Description	Mandatory (Yes or No)
Upload Request Business Object	Used to specify the business object that you want to use while creating the upload request.	Yes
Description	Used to specify the description for the upload request type.	Yes
Detailed Description	Used to specify additional information about the upload request type.	No
Status	Used to indicate the status of the upload request type. The valid values are: <ul style="list-style-type: none"> <li>• Active</li> <li>• Inactive</li> </ul>	Yes
File Size (KB)	Used to specify the maximum size of file (in kilobytes) that you can upload using the upload request type. If you upload a file which exceeds the maximum file size, the system will not allow you to upload the file. <div style="border: 1px solid black; padding: 5px; margin-top: 10px;"> <p><b>Note:</b> This field appears when the business object is <b>Adjustment Upload Request Type</b>.</p> </div>	Yes

Field Name	Field Description	Mandatory (Yes or No)
Defer Algorithm	<p>Used to attach an algorithm that will be triggered when you create entities (for example, adjustments) or approve the uploaded file (for example, adjustment data file). This algorithm checks whether the number of records in the uploaded file exceeds the online record process limit (defined in the Defer algorithm). If the number of records in the uploaded file does not exceed the online record process limit, the system creates the entities (for example, adjustments) in the real time (i.e. immediately). However, if the number of records in the uploaded file exceeds the online record process limit, the system creates the entities (for example, adjustments) in the deferred mode.</p> <div data-bbox="662 703 1177 1220" style="border: 1px solid black; padding: 5px;"> <p><b>Note:</b> Deferred mode means in the background when the <b>Upload Request Periodic Monitor (C1-UPLRQ)</b> batch is invoked. You can configure the <b>Upload Request Periodic Monitor (C1-UPLRQ)</b> batch such that it is executed at regular intervals. When the <b>Upload Request Periodic Monitor (C1-UPLRQ)</b> batch is invoked, the system checks whether there are any upload requests in the <b>Deferred</b> status. If there is an upload request in the <b>Deferred</b> status, the system creates the entities (for example, adjustments).  This field appears when the business object is <b>Adjustment Upload Request Type</b>.</p> </div>	Yes
Entity Business Object	<p>Used to indicate for creating Business Object of the entity using the upload request type.</p> <div data-bbox="662 1325 1177 1482" style="border: 1px solid black; padding: 5px;"> <p><b>Note:</b> The <b>Search</b>  icon appears corresponding to this field. On clicking the <b>Search</b> icon, the <b>Business Object Search</b> window appears.</p> </div>	No
Approval Required	<p>Used to indicate whether approval is required for a file which is uploaded using the upload request type.</p>	No
Approval To Do Type	<p>Used to indicate that To Do entry of the specified To Do type must be created when you submit the upload request for approval.</p> <div data-bbox="662 1734 1177 1892" style="border: 1px solid black; padding: 5px;"> <p><b>Note:</b> The <b>Search</b>  icon appears corresponding to this field. On clicking the <b>Search</b> icon, the <b>To Do Type Search</b> window appears.</p> </div>	<p>Yes (Conditional)</p> <div data-bbox="1198 1671 1463 1818" style="border: 1px solid black; padding: 5px;"> <p><b>Note:</b> This field is required when the <b>Approval Required</b> check box is selected.</p> </div>

Field Name	Field Description	Mandatory (Yes or No)
Approval To Do Role	Used to indicate that users with the specified To Do role can only approve the upload request submitted for approval.	Yes (Conditional) <b>Note:</b> This field is required when the <b>Approval Required</b> check box is selected.
FK Reference	Used to indicate the FK Reference code to display the entity information. <b>Note:</b> The <b>Search</b>  icon appears corresponding to this field. On clicking the <b>Search</b> icon, the <b>Foreign Key Search</b> window appears. This field appears when the business object is <b>Upload Request Type</b> .	No

In addition, this section contains the following fields in the grid:

**Note:** The below section appears when the business object is **Adjustment Upload Request Type**.



Field Name	Field Description	Mandatory (Yes or No)
Match Type	Used to indicate the match type using which you want to create adjustments when you upload a file using the upload request type. The valid values are: <ul style="list-style-type: none"> <li>Contract</li> <li>Contract Type</li> </ul>	Yes (Conditional) <b>Note:</b> This field is required when you select the <b>Adjustment Upload Request</b> option from the <b>Upload Request Business Object</b> list.
Algorithm	Used to attach an algorithm that will be triggered when you upload an adjustment data file. This algorithm determines the contract against which the adjustment must be created.	Yes (Conditional) <b>Note:</b> This field is required when you select the match type from the respective field.

**Tip:** Alternatively, you can click the **Edit** button in the **Upload Request Type** zone to edit the details of the upload request type.

#### 4. Modify the required details.

**Note:**

You can search for an algorithm by clicking the **Search**  icon corresponding to the respective field.

If you want to associate more than one match type with the upload request type, click the **Add**  icon and then specify the details. However, if you want to remove a match type from the upload request type, click the **Delete**  icon corresponding to the match type.

#### 5. Define, edit, or remove characteristics from the upload request type, if required.

6. Click **Save**.

The changes made to the upload request type are saved.

### Related Topics

For more information on...	See...
<b>Upload Request Type</b> screen	<a href="#">Upload Request Type</a> on page 1109
<b>Upload Request Type List</b> zone	<a href="#">Upload Request Type List</a> on page 1110
<b>Upload Request Type</b> zone	<a href="#">Upload Request Type</a> on page 1111
How to define characteristics for an upload request type	<a href="#">Defining Characteristics for an Upload Request Type</a> on page 1120

## Copying an Upload Request Type

Instead of creating an upload request type from scratch, you can create a new upload request type using an existing upload request type. This is possible through copying an upload request type. On copying an upload request type, the details including the match types (only for adjustments) and characteristics are copied to the new upload request type. You can then edit the details, if required.

### Prerequisites

To copy an upload request type, you should have:

- Upload request type (whose copy you want to create) defined in the application
- Upload request business objects defined in the application
- Defer algorithm defined using the **C1-UPLDEFEVL** algorithm type
- Defer algorithm for upload is defined using the **C1-DEFERUPLD** algorithm type
- Algorithm defined using the **C1-MTCIALG** algorithm type when you want to create adjustment using the Contract match type
- Algorithm defined using the **C1-MTCTALG** algorithm type when you want to create adjustment using the Contract Type match type
- **C1-ADJUP** To Do type assigned to a To Do role whose users must receive To Do entries generated while submitting an upload request for approval
- **C1-UPLAPPENT** To Do type assigned to a To Do role whose users must receive To Do generated while submitting an upload request for approval

### Procedure

To copy an upload request type:

1. Click the **Admin** link in the **Application** toolbar.  
A list appears.
2. From the **Admin** menu, select **U** and then click **Upload Request Type**.  
A sub-menu appears.
3. In the **Upload Request Type List** zone, click the **Duplicate**  icon in the **Duplicate** column corresponding to the upload request type whose copy you want to create.



The **Upload Request Type** screen appears. It contains the following sections:

- **Main** – Used to specify basic details about the upload request type.
- **Characteristics** – Used to define characteristics for the upload request type.

The **Main** section contains the following fields:

Field Name	Field Description	Mandatory (Yes or No)
Upload Request Type	Used to specify the upload request type.	Yes
Upload Request Type Business Object	Indicates the upload request type business object used while defining the upload request type (whose copy you want to create).	Not applicable
Upload Request Business Object	Used to specify the business object that you want to use while creating the upload request.	Yes
Description	Used to specify the description for the upload request type.	Yes
Detailed Description	Used to specify additional information about the upload request type.	No
Status	Used to indicate the status of the upload request type. The valid values are: <ul style="list-style-type: none"> <li>• Active</li> <li>• Inactive</li> </ul>	Yes
File Size (KB)	Used to specify the maximum size of file (in kilobytes) that you can upload using the upload request type. If you upload a file which exceeds the maximum file size, the system will not allow you to upload the file. <div style="border: 1px solid black; padding: 5px; margin-top: 10px;"> <p><b>Note:</b> This field appears when the business object is <b>Adjustment Upload Request Type</b>.</p> </div>	Yes

Field Name	Field Description	Mandatory (Yes or No)
Defer Algorithm	<p>Used to attach an algorithm that will be triggered when you create entities (for example, adjustments) or approve the uploaded file (for example, adjustment data file). This algorithm checks whether the number of records in the uploaded file exceeds the online record process limit (defined in the Defer algorithm). If the number of records in the uploaded file does not exceed the online record process limit, the system creates the entities (for example, adjustments) in the real time (i.e. immediately). However, if the number of records in the uploaded file exceeds the online record process limit, the system creates the entities (for example, adjustments) in the deferred mode.</p> <div data-bbox="659 705 1175 1213" style="border: 1px solid black; padding: 5px;"> <p><b>Note:</b></p> <p>Deferred mode means in the background when the <b>Upload Request Periodic Monitor (C1-UPLRQ)</b> batch is invoked. You can configure the <b>Upload Request Periodic Monitor (C1-UPLRQ)</b> batch such that it is executed at regular intervals. When the <b>Upload Request Periodic Monitor (C1-UPLRQ)</b> batch is invoked, the system checks whether there are any upload requests in the <b>Deferred</b> status. If there is an upload request in the <b>Deferred</b> status, the system creates the entities (for example, adjustments).</p> <p>This field appears when the business object is <b>Adjustment Upload Request Type</b>.</p> </div>	Yes
Entity Business Object	<p>Used to indicate to create the copy of Business Object of the entity using the upload request type.</p> <div data-bbox="659 1325 1175 1591" style="border: 1px solid black; padding: 5px;"> <p><b>Note:</b></p> <p>The <b>Search</b>  icon appears corresponding to this field. On clicking the <b>Search</b> icon, the <b>Business Object Search</b> window appears.</p> <p>This field appears when the business object is <b>Upload Request Type</b>.</p> </div>	No
Approval Required	Used to indicate whether approval is required for a file which is uploaded using the upload request type.	No

Field Name	Field Description	Mandatory (Yes or No)
Approval To Do Type	Used to indicate that To Do entry of the specified To Do type must be created when you submit the upload request for approval.  <b>Note:</b> The <b>Search</b>  icon appears corresponding to this field. On clicking the <b>Search</b> icon, the <b>To Do Type Search</b> window appears.	Yes (Conditional)  <b>Note:</b> This field is required when the <b>Approval Required</b> check box is selected.
Approval To Do Role	Used to indicate that users with the specified To Do role can only approve the upload request submitted for approval.	Yes (Conditional)  <b>Note:</b> This field is required when the <b>Approval Required</b> check box is selected.
FK Reference	Used to indicate the FK Reference code to display the entity information.  <b>Note:</b> The <b>Search</b>  icon appears corresponding to this field. On clicking the <b>Search</b> icon, the <b>Foreign Key Search</b> window appears.  This field appears when the business object is <b>Upload Request Type</b> .	No

In addition, this section contains the following fields in the grid:

**Note:** The below section appears when the business object is **Adjustment Upload Request Type**.

Field Name	Field Description	Mandatory (Yes or No)
Match Type	Used to indicate the match type using which you want to create adjustments when you upload a file using the upload request type. The valid values are: <ul style="list-style-type: none"> <li>• Contract</li> <li>• Contract Type</li> </ul>	Yes (Conditional)  <b>Note:</b> This field is required when you select the <b>Adjustment Upload Request</b> option from the <b>Upload Request Business Object</b> list.
Algorithm	Used to attach an algorithm that will be triggered when you upload an adjustment data file. This algorithm determines the contract against which the adjustment must be created.	Yes (Conditional)  <b>Note:</b> This field is required when you select the match type from the respective field.



**Tip:** Alternatively, you can click the **Duplicate** button in the **Upload Request Type** zone to create a copy of the upload request type.

4. Enter the required details.



**Note:**

You can search for an algorithm by clicking the **Search**  icon corresponding to the respective field.

If you want to associate more than one match type with the upload request type, click the **Add**  icon and then specify the details. However, if you want to remove a match type from the upload request type, click the **Delete**  icon corresponding to the match type.

5. Define, edit, or remove characteristics from the upload request type, if required.
6. Click **Save**.

The new upload request type is defined.

**Related Topics**

For more information on...	See...
<b>Upload Request Type</b> screen	<a href="#">Upload Request Type</a> on page 1109
<b>Upload Request Type List</b> zone	<a href="#">Upload Request Type List</a> on page 1110
<b>Upload Request Type</b> zone	<a href="#">Upload Request Type</a> on page 1111
How to define characteristics for an upload request type	<a href="#">Defining Characteristics for an Upload Request Type</a> on page 1120

**Mapping an Upload Request Type****Prerequisites**

To map an upload request type, you should have:

- Upload request type (whose columns you want to map with the CSV file) defined in the application
- Upload request business objects defined in the application

**Note:** Once an upload request type is used for creating an upload request, then mapping for the same cannot be edited. Duplicating the upload request type will not duplicate the mapping data. You have to add the mapping details manually after duplicating an upload request type.

**Procedure**

To map an upload request type:

1. Click the **Admin** link in the **Application** toolbar.  
A list appears.
2. From the **Admin** menu, select **U** and then click **Upload Request Type**.  
A sub-menu appears.
3. In the **Upload Request Type List** zone, click the **Mapping**  icon in the **Mapping** column corresponding to the upload request type whose columns you want to map with the CSV file.

The **Upload Request Type Mapping** screen appears. It contains the following field:

**Note:** The **Mapping** icon is applicable only for upload request type created using **Upload Request Type (C1-UplRequestType)** business object, and it is not applicable for upload request type created using **Adjustment Upload Request Type (C1-AdjRequestType)** business object.

Field Name	Field Description	Mandatory (Yes or No)
Upload Request Type	Indicates the upload request type.	Not applicable

The **Upload Request Type Mapping** screen also contains the following columns:

Column Name	Column Description	Mandatory (Yes or No)
CSV Column Header	Used to specify the rows correspond to the columns in CSV file.	Yes (Conditional) <b>Note:</b> This column is required when you search the <b>Data Records</b> zone in the <b>Upload Request</b> screen.
Use for Searching	Used to indicate whether the defined <b>CSV Column Header</b> is searchable or not. <b>Note:</b> Upto 10 rows can be selected as searchable rows.	Yes (Conditional) <b>Note:</b> This column is required to be selected to be shown in the <b>Data Records</b> zone in the <b>Upload Request</b> screen
Sequence Number	Used to specify the sequence of the searchable fields. <b>Note:</b> Searchable rows should have sequence less than or equal to 10.	Yes (Conditional) <b>Note:</b> This column is required to be selected to be shown sequentially in the <b>Data Records</b> zone in the <b>Upload Request</b> screen

- Enter the required details.

**Note:** If you want to add more than one column names mapped to the upload request type, click the **Add** (+) icon and then specify the details. However, if you want to remove a column name mapped to the upload request type, click the **Delete** (🗑️) icon corresponding to the column header.

- Click **Save**.

The columns are mapped to the CSV files for upload request type.

### **Related Topics**

For more information on...	See...
<b>Upload Request Type</b> screen	<a href="#">Upload Request Type</a> on page 1109
<b>Upload Request Type List</b> zone	<a href="#">Upload Request Type List</a> on page 1110
<b>Upload Request Type</b> zone	<a href="#">Upload Request Type</a> on page 1111

## Deleting an Upload Request Type

### **Procedure**

To delete an upload request type:

- Click the **Admin** link in the **Application** toolbar.

A list appears.

- From the **Admin** menu, select **U** and then click **Upload Request Type**.

A sub-menu appears.

- In the **Upload Request Type List** zone, click the **Delete** () icon in the **Delete** column corresponding to the upload request type that you want to delete.

A message appears confirming whether you want to delete the upload request type.

**Note:** You can delete an upload request type only when you have not uploaded a file (i.e. created an upload request) using the upload request type.

**Tip:** Alternatively, you can click the **Delete** button in the **Upload Request Type** zone to delete the upload request type.

- Click **OK**.

The upload request type is deleted.

### Related Topics

For more information on...	See...
<b>Upload Request Type</b> screen	<a href="#">Upload Request Type</a> on page 1109
<b>Upload Request Type List</b> zone	<a href="#">Upload Request Type List</a> on page 1110
<b>Upload Request Type</b> zone	<a href="#">Upload Request Type</a> on page 1111

## Viewing the Upload Request Type Details

### Procedure

To view the details of an upload request type:

- Click the **Admin** link in the **Application** toolbar.  
A list appears.
- From the **Admin** menu, select **U** and then click **Upload Request Type**.  
A sub-menu appears.
- Click the **Search** option from the **Upload Request Type** sub-menu.  
The **Upload Request Type** screen appears.
- In the **Upload Request Type List** zone, click the **Broadcast** () icon corresponding to the upload request type whose details you want to view.  
The **Upload Request Type** zone appears.
- View the details of the upload request type in the **Upload Request Type** zone.

### Related Topics

For more information on...	See...
<b>Upload Request Type</b> screen	<a href="#">Upload Request Type</a> on page 1109
<b>Upload Request Type List</b> zone	<a href="#">Upload Request Type List</a> on page 1110
<b>Upload Request Type</b> zone	<a href="#">Upload Request Type</a> on page 1111

## Adjustment Upload Request (Used for Searching)

---

The **Adjustment Upload Request** screen allows you to search for an adjustment upload request using various search criteria. Through this screen, you can:

- Upload an adjustment data file
- Cancel an adjustment data file
- View the details of an adjustment upload request
- View all adjustment records which are uploaded through an adjustment data file
- Create adjustments for an adjustment data file
- Submit an adjustment data file for approval
- Approve or reject an adjustment data file
- View the log of an adjustment upload request
- Add a log entry for an adjustment upload request

This screen consists of the following zones:

- [Search Adjustment Upload Request](#) on page 1132
- [Adjustment Upload Request](#) on page 1140
- [Adjustment Data Records](#) on page 1143

### Search Adjustment Upload Request

The **Search Adjustment Upload Request** zone allows you to search for an adjustment upload request using various search criteria. This zone contains the following two sections:

- **Search Criteria** — The fields in the **Search Criteria** section change depending on the query option selected. At present, there is only one query option named **Upload Request**. On selecting the **Upload Request** query option, the **Search Criteria** section contains the following fields:

Field Name	Field Description	Mandatory (Yes or No)
Upload Request Type	Used to search adjustment upload requests which are created using a particular upload request type.	No

Field Name	Field Description	Mandatory (Yes or No)
Status	Used to search adjustment upload requests with a particular status. The valid values are: <ul style="list-style-type: none"> <li>• Approved</li> <li>• Cancelled</li> <li>• Completed</li> <li>• Create Adjustment</li> <li>• Creating Adjustment</li> <li>• Deferred</li> <li>• Pending</li> <li>• Rejected</li> <li>• Pending For Approval</li> </ul>	No
Upload From Date	Used to search adjustment upload requests which are created from a particular date onwards. <b>Note:</b> By default, the current date appears in this field.	No
To	Used to search adjustment upload requests which are created till a particular date. <b>Note:</b> By default, the current date appears in this field.	No
File Name	Used to search an adjustment upload request which is created while uploading an adjustment data file.	No

**Note:** You must specify at least one search criterion while searching for an adjustment upload request.

- **Search Results** — On clicking the **Refresh** button, the search results appear based on the specified search criteria. The **Search Results** section contains the following columns:

Column Name	Column Description
Upload Date	Displays the date and time when the adjustment data file is uploaded in the system.
Upload Request Information	Displays information about the adjustment upload request. <b>Note:</b> It has a link. On clicking the link, the <b>Adjustment Upload Request</b> screen appears where you can view the details of the respective upload request.
Status	Indicates the status of the adjustment upload request.
Upload Request Type	Indicates the upload request type using which the adjustment data file is uploaded in the system.
File Name	Displays the name of the adjustment data file.

You can upload an adjustment data file by clicking the **Upload** link in the upper right corner of this zone.

### **Related Topics**

For more information on...	See...
How to search for an adjustment upload request	<a href="#">Searching for an Adjustment Upload Request</a> on page 1134
How to upload an adjustment data file	<a href="#">Uploading an Adjustment Data File</a> on page 1134
How to view the details of an adjustment upload request	<a href="#">Viewing the Adjustment Upload Request Details</a> on page 1139

## Searching for an Adjustment Upload Request

### Prerequisites

To search for an adjustment upload request, you should have:

- Upload request types defined in the application

### Procedure

To search for an adjustment upload request:

1. Click the **Menu** link in the **Actions/Navigation** area.  
A list appears.
2. Select the **Main Menu** option from the list.
3. From the **Main Menu**, select **Financial** and then click **Adjustment Upload Request**.

The **Adjustment Upload Request** screen appears.

4. Enter the search criteria in the **Search Adjustment Upload Request** zone.

**Note:** ORMB search engine supports wildcard search, where you can substitute the percentage (%) symbol as a stand in for any word or letter in a search criteria. You can use the ‘%’ wildcard character in all input fields except the date and ID fields. The ‘%’ wildcard character is suffixed automatically at the end of the partial search criteria. Therefore, you may or may not specify the wildcard character at the end of the partial search criteria. However, you have to prefix the wildcard character manually wherever required.

5. Click **Search**.

A list of adjustment upload requests that meet the search criteria appears in the **Search Results** section.

### Related Topics

For more information on...	See...
<b>Adjustment Upload Request</b> screen	<a href="#">Adjustment Upload Request (Used for Searching)</a> on page 1132
<b>Search Adjustment Upload Request</b> zone	<a href="#">Search Adjustment Upload Request</a> on page 1132

## Uploading an Adjustment Data File

### Prerequisites

To upload an adjustment data file, you should have:

- Upload request types defined in the application
- Adjustment data in the required CSV file format

### Procedure

To upload an adjustment data file:

1. Click the **Menu** link in the **Actions/Navigation** area.  
A list appears.
2. Select the **Main Menu** option from the list.
3. From the **Main Menu**, select **Financial** and then click **Adjustment Upload Request**.  
The **Adjustment Upload Request** screen appears.
4. Click the **Upload** link in the upper right corner of the **Search Adjustment Upload Request** zone.  
The **Upload Adjustment Data File** screen appears. It contains the following fields:

Field Name	Field Description	Mandatory (Yes or No)
Upload Request Type	Used to indicate the upload request type using which you want to upload the adjustment data file.  <b>Note:</b> The list includes only those upload request types which are in the <b>Active</b> status.	Yes
Replace Existing File	Used to indicate whether you want to replace any existing file in the system. You must select this check box when you want to upload the same file once again.  <b>Note:</b> You can replace an existing file only when the adjustment upload request is in the <b>Pending</b> or <b>Cancelled</b> status.	No
File Name	Used to specify the name and path of the adjustment data file that you want to upload.  <b>Note:</b> You can also click the <b>Browse</b> button corresponding to this field to browse to the location where the adjustment data file is available in the system.	Yes

5. Select the upload request type using which you want to upload the adjustment data file.
6. Click the **Browse** button corresponding to the **File Name** field.  
The **Choose File to Upload** dialog box appears.
7. Browse to the location where the adjustment data file that you want to upload is available.
8. Click **Open**.  
The adjustment data file name and path appears in the **File Name** field.
9. Click **Submit**.

A grid appears which helps you to preview all records in the adjustment data file. It contains the following columns:

Column Name	Column Description
Errors	Indicates the reason why the adjustment record is invalid. If there are multiple reasons, the comma-separated list of error messages appears in this column.  <b>Note:</b> This column appears only when you click the <b>Save</b> button.
Account Identifier Type	Indicates the account identifier type.

Column Name	Column Description
Account Identifier	Displays the value of the account identifier type.
Account ID	Indicates the account for which the adjustment must be created.
Match Type	Indicates the match type using which the adjustment must be created.
Match Value	Indicates the entity (such as contract, contract type, and so on) against which the adjustment must be created.
Adjustment Type	Indicates the adjustment type using which the adjustment must be created.
Adjustment Amount	Displays the adjustment amount.
Currency Code	Indicates the currency in which the adjustment must be created.
Comments	Displays additional information about the adjustment.
Bill ID	Indicates the bill on which the adjustment must be created.
Arrears Date	Displays the date from when the amount is outstanding on the bill.
Char Type 1	Indicates the characteristic that must be defined for the adjustment.
Char Value 1	Displays the value of the characteristic type.
Char Type 2	Indicates the characteristic that must be defined for the adjustment.
Char Value 2	Displays the value of the characteristic type.
Char Type 3	Indicates the characteristic that must be defined for the adjustment.
Char Value 3	Displays the value of the characteristic type.
Char Type 4	Indicates the characteristic that must be defined for the adjustment.
Char Value 4	Displays the value of the characteristic type.
Char Type 5	Indicates the characteristic that must be defined for the adjustment.
Char Value 5	Displays the value of the characteristic type.

**Note:** If you upload an adjustment data file which exceeds the maximum file size defined in the upload request type, the system will not allow you to upload the file.

#### 10. Click **Save**.

The validation process starts immediately. The adjustment record is considered as invalid when:

- Account ID, Account Identifier Type, Account Identifier, Adjustment Type, Currency, Bill ID, Characteristic Type, Characteristic Value, or Match Type is invalid.
- Match Type, Match Value, Adjustment Type, Adjustment Amount, Currency, or Characteristic Value is missing.
- Contract ID does not exist in the system.
- The contract is in the **Cancelled** status.
- Contract type does not exist in the system.
- Account Identifier Type, Account Identifier, or Account ID is missing when the match type is Contract Type.
- No active contract of the specified contract type is available.
- Adjustment amount precision does not match the precision (decimal positions) defined for the currency.
- The adjustment type is not included in the adjustment type profile which is attached to the contract type.



- The characteristic type is not associated with the adjustment type.

If there is an invalid record in the adjustment data file, you will not be able to upload the file.

### Related Topics

For more information on...	See...
Adjustment Upload Request screen	<a href="#">Adjustment Upload Request (Used for Searching)</a> on page 1132
Search Adjustment Upload Request zone	<a href="#">Search Adjustment Upload Request</a> on page 1132

## Replacing an Adjustment Data File

### Prerequisites

To replace an existing adjustment data file, you should have:

- Upload request types defined in the application
- Adjustment data in the required CSV file format

### Procedure

To replace an existing adjustment data file:

1. Click the **Menu** link in the **Actions/Navigation** area.  
A list appears.
2. Select the **Main Menu** option from the list.
3. From the **Main Menu**, select **Financial** and then click **Adjustment Upload Request**.  
The **Adjustment Upload Request** screen appears.
4. Click the **Upload** link in the upper right corner of the **Search Adjustment Upload Request** zone.

The **Adjustment Upload Data File** screen appears. It contains the following fields:

Field Name	Field Description	Mandatory (Yes or No)
Upload Request Type	Used to indicate the upload request type using which you want to upload the adjustment data file.  <b>Note:</b> The list includes only those upload request types which are in the <b>Active</b> status.	Yes
Replace Existing File	Used to indicate whether you want to replace any existing file in the system. You must select this check box when you want to upload the same file once again.  <b>Note:</b> You can replace an existing file only when the adjustment upload request is in the <b>Pending</b> or <b>Cancelled</b> status.	No

Field Name	Field Description	Mandatory (Yes or No)
File Name	Used to specify the name and path of the adjustment data file that you want to upload.  <b>Note:</b> You can also click the <b>Browse</b> button corresponding to this field to browse to the location where the adjustment data file is available in the system.	Yes

5. Select the upload request type using which you want to upload the adjustment data file.
6. Select the **Replace Existing File** check box to indicate that you want to replace an existing adjustment data file.
7. Click the **Browse** button corresponding to the **File Name** field.  
The **Choose File to Upload** dialog box appears.
8. Browse to the location where the adjustment data file that you want to upload is available.
9. Click **Open**.

The adjustment data file name and path appears in the **File Name** field.

10. Click **Submit**.

A grid appears which helps you to preview all records in the adjustment data file. It contains the following columns:

Column Name	Column Description
Errors	Indicates the reason why the adjustment record is invalid. If there are multiple reasons, the comma-separated list of error messages appears in this column.  <b>Note:</b> This column appears only when you click the <b>Save</b> button.
Account Identifier Type	Indicates the account identifier type.
Account Identifier	Displays the value of the account identifier type.
Account ID	Indicates the account for which the adjustment must be created.
Match Type	Indicates the match type using which the adjustment must be created.
Match Value	Indicates the entity (such as contract, contract type, and so on) against which the adjustment must be created.
Adjustment Type	Indicates the adjustment type using which the adjustment must be created.
Adjustment Amount	Displays the adjustment amount.
Currency Code	Indicates the currency in which the adjustment must be created.
Comments	Displays additional information about the adjustment.
Bill ID	Indicates the bill on which the adjustment must be created.
Arrears Date	Displays the date from when the amount is outstanding on the bill.
Char Type 1	Indicates the characteristic that must be defined for the adjustment.
Char Value 1	Displays the value of the characteristic type.
Char Type 2	Indicates the characteristic that must be defined for the adjustment.
Char Value 2	Displays the value of the characteristic type.
Char Type 3	Indicates the characteristic that must be defined for the adjustment.

Column Name	Column Description
Char Value 3	Displays the value of the characteristic type.
Char Type 4	Indicates the characteristic that must be defined for the adjustment.
Char Value 4	Displays the value of the characteristic type.
Char Type 5	Indicates the characteristic that must be defined for the adjustment.
Char Value 5	Displays the value of the characteristic type.

**Note:** If you upload an adjustment data file which exceeds the maximum file size defined in the upload request type, the system will not allow you to upload the file.

#### 11. Click **Save**.

The validation process starts immediately. The adjustment record is considered as invalid when:

- Account ID, Account Identifier Type, Account Identifier, Adjustment Type, Currency, Bill ID, Characteristic Type, Characteristic Value, or Match Type is invalid.
- Match Type, Match Value, Adjustment Type, Adjustment Amount, Currency, or Characteristic Value is missing.
- Contract ID does not exist in the system.
- The contract is in the **Cancelled** status.
- Contract type does not exist in the system.
- Account Identifier Type, Account Identifier, or Account ID is missing when the match type is Contract Type.
- No active contract of the specified contract type is available.
- Adjustment amount precision does not match the precision (decimal positions) defined for the currency.
- The adjustment type is not included in the adjustment type profile which is attached to the contract type.
- The characteristic type is not associated with the adjustment type.

If there is an invalid record in the adjustment data file, you will not be able to upload the file.

#### Related Topics

For more information on...	See...
<b>Adjustment Upload Request</b> screen	<a href="#">Adjustment Upload Request (Used for Searching)</a> on page 1132
<b>Search Adjustment Upload Request</b> zone	<a href="#">Search Adjustment Upload Request</a> on page 1132

## Viewing the Adjustment Upload Request Details

### Procedure

To view the details of an adjustment upload request:

1. Search for an adjustment upload request in the **Adjustment Upload Request** screen.
2. In the **Search Results** section, click the link in the **Upload Request Information** column corresponding to the adjustment upload request whose details you want to view.

The **Adjustment Upload Request** screen appears. It contains the following two tabs:

- **Main** – This tab contains the following two zones:

- **Adjustment Upload Request** – Displays the details of the adjustment upload request.
  - **Adjustment Data Records** – Lists the adjustment records which are uploaded through the adjustment data file.
  - **Log** – This tab lists the complete trail of actions performed on the adjustment upload request.
3. View the details of the adjustment upload request in the **Adjustment Upload Request** zone.
  4. View the list of adjustment records which are uploaded through the adjustment data file in the **Adjustment Data Records** zone.

### Related Topics

For more information on...	See...
How to search for an adjustment upload request	<a href="#">Searching for an Adjustment Upload Request</a> on page 1134
<b>Adjustment Upload Request</b> zone	<a href="#">Adjustment Upload Request</a> on page 1140
<b>Adjustment Data Records</b> zone	<a href="#">Adjustment Data Records</a> on page 1143

## Adjustment Upload Request (Used for Viewing)

---

The **Adjustment Upload Request** screen allows you to:

- Edit the details of an adjustment upload request
- Delete or cancel an adjustment upload request
- View the details of an adjustment upload request
- Submit an adjustment upload request for processing
- Approve or reject an adjustment upload request
- Request the submitter to resubmit an adjustment upload request for approval
- Withdraw an adjustment upload request
- View the log of an adjustment upload request
- Add a log entry for an adjustment upload request

It consists of the following tabs:

- [Adjustment Upload Request - Main](#) on page 1140
- 

### Adjustment Upload Request - Main

The **Main** tab displays information about the adjustment upload request. It contains the following zones:

- [Adjustment Upload Request](#) on page 1140
- [Adjustment Data Records](#) on page 1143

#### Adjustment Upload Request

The **Adjustment Upload Request** zone displays the details of the adjustment upload request. This zone contains the following sections:

- **Header** — This section provides basic information about the upload request. It contains the following fields:

Field Name	Field Description
Upload Request Information	<p>Displays information about the adjustment upload request. The information string contains the following comma-separated values:</p> <ul style="list-style-type: none"> <li>• Upload Request Type Description</li> <li>• Status Description</li> <li>• Upload Request ID</li> </ul> <p><b>Note:</b> This information string is generated using the <b>C1-FLREQ-INF</b> algorithm which is attached to the <b>Information</b> system event in the adjustment upload request business object. If you want to display a different information string, you need to define a custom algorithm type and attach the algorithm in the adjustment upload request business object.</p>
Status	<p>Indicates the status of the adjustment upload request. The valid values are:</p> <ul style="list-style-type: none"> <li>• Approved</li> <li>• Cancelled</li> <li>• Completed</li> <li>• Create Adjustment</li> <li>• Creating Adjustment</li> <li>• Deferred</li> <li>• Pending</li> <li>• Rejected</li> <li>• Pending for Approval</li> </ul>
Status Reason	<p>Indicates the reason why the adjustment data file is cancelled or rejected.</p> <p><b>Note:</b> This field appears only when the adjustment upload request is in the <b>Cancelled</b> or <b>Rejected</b> status.</p>
File Name	<p>Displays the name of the adjustment data file for which the adjustment upload request is created.</p>

- **Record Actions** — This section contains the following buttons:

Button Name	Button Description
Cancel File	<p>Used to cancel an adjustment data file.</p> <p><b>Note:</b> The <b>Cancel File</b> button appears only when the adjustment upload request is in the <b>Pending</b> status.</p>

Button Name	Button Description
Create Adjustment	Used to create adjustments for the records which are uploaded through the adjustment data file.  <b>Note:</b> The <b>Create Adjustment</b> button appears only when: <ul style="list-style-type: none"> <li>The adjustment upload request is in the <b>Pending</b> status.</li> <li>The approval workflow process is not configured for the upload request type using which the adjustment data file is uploaded.</li> </ul>
Submit for Approval	Used to submit the adjustment data file for approval.  <b>Note:</b> The <b>Submit for Approval</b> button appears only when: <ul style="list-style-type: none"> <li>The adjustment upload request is in the <b>Pending</b> status.</li> <li>The approval workflow process is configured for the upload request type using which the adjustment data file is uploaded.</li> </ul>
Approve	Used to approve the adjustment data file.  <b>Note:</b> The <b>Approve</b> button appears only when: <ul style="list-style-type: none"> <li>The adjustment upload request is in the <b>Pending for Approval</b> status.</li> <li>A user with the approval To Do role is reviewing the adjustment data file.</li> </ul>
Reject	Used to reject the adjustment data file.  <b>Note:</b> The <b>Reject</b> button appears only when: <ul style="list-style-type: none"> <li>The adjustment upload request is in the <b>Pending for Approval</b> status.</li> <li>A user with the approval To Do role is reviewing the adjustment data file.</li> </ul>

**Note:** The **Record Actions** section does not contain buttons when the status of the adjustment upload request is **Cancelled, Completed, Deferred, or Rejected**.

- **Record Information** — This section contains the following fields:

Field Name	Field Description
Business Object	Indicates the business object using which the adjustment upload request is created.  <b>Note:</b> It has a link. On clicking the link, the <b>Business Object</b> screen appears with the details of the respective business object.
Status Date/Time	Displays the date and time when the adjustment upload request status is updated.
Create Date/Time	Displays the date and time when the adjustment upload request is created.

### **Related Topics**

For more information on...	See...
How to view the details of an adjustment upload request	<a href="#">Viewing the Adjustment Upload Request Details</a> on page 1139
How to cancel an adjustment data file	<a href="#">Cancelling an Adjustment Data File</a> on page 1144
How to create adjustments for an adjustment data file	<a href="#">Creating Adjustments for an Adjustment Data File</a> on page 1145
How to submit an adjustment data file for approval	<a href="#">Submitting an Adjustment Data File for Approval</a> on page 1146
How to approve an adjustment data file	<a href="#">Approving an Adjustment Data File</a> on page 1147
How to reject an adjustment data file	<a href="#">Rejecting an Adjustment Data File</a> on page 1148

### Adjustment Data Records

The **Adjustment Data Records** zone lists the adjustment records which are uploaded through the adjustment data file. This zone contains the following columns:

Column Name	Column Description
Adjustment Information	<p>Displays information about the adjustment that is created using the adjustment record.</p> <div style="border: 1px solid black; padding: 5px;"> <p><b>Note:</b></p> <p>The data appears in this column only when the status of the adjustment upload request is <b>Completed</b>.</p> <p>It has a link. On clicking the link, the <b>Adjustment</b> screen appears with the details of the respective adjustment.</p> <p>The information string appears only when an algorithm of the <b>C1-ADI-INFO</b> algorithm type is attached to the <b>Adjustment Information</b> system event in the <b>Algorithms</b> tab of the <b>Installation Options — Framework</b> screen.</p> </div>
Account Identifier Type	Indicates the account identifier type.
Account Identifier	Displays the value of the account identifier type.
Account ID	Indicates the account for which the adjustment must be created.
Adjustment Match Value	Indicates the contract against which the adjustment must be created.
Adjustment Type	Indicates the adjustment type using which the adjustment must be created.
Adjustment Amount	Displays the adjustment amount.
Comments	Displays additional information about the adjustment.
Bill ID	Indicates the bill on which the adjustment must be created.
Arrears Date	Displays the date from when the amount is outstanding on the bill.
Char Type 1, Char Type 2, ....., Char Type 5	Indicates the characteristic that must be defined for the adjustment.
Char Value 1, Char Value 2, ....., Char Value 5	Displays the value of the characteristic type.

### Related Topics

For more information on...	See...
How to view the details of an adjustment upload request	<a href="#">Viewing the Adjustment Upload Request Details</a> on page 1139
How to view the adjustment records uploaded through an adjustment data file	<a href="#">Viewing All Records of an Adjustment Data File</a>

## Adjustment Upload Request - Log

The **Log** tab contains the following zone:

- [Adjustment Upload Request - Log](#) on page 1144

### Adjustment Upload Request Log

The **Upload Request Log** zone lists the complete trail of actions performed on the adjustment upload request. It contains the following columns:

Column Name	Column Description
Date/Time	Displays the date and time when the action was performed on the funding request.
Details	Displays the details of the action performed on the funding request.
User	Indicates the user who has performed the action on the funding request.
Log Type	Indicates the type of log.
Related Object	Indicates the object or entity which is created when the action is performed on the funding request.  <b>Note:</b> At present, no data appears in this column. The implementation team can build the custom logic to meet the business requirements.
Status Reason	Indicates the reason why the funding request was rejected by the approver.  <b>Note:</b> The data appears in this column only when the funding request is in the <b>Rejected</b> status.

**Note:** You can manually add a log entry for the adjustment upload request by clicking the **Add Log Entry** link in the upper right corner of the **Adjustment Upload Request Log** zone.

### Related Topics

For more information on...	See...
How to view the log of an adjustment upload request	<a href="#">Viewing the Log of an Adjustment Upload Request</a> on page 1149
How to add a log entry for an adjustment upload request	<a href="#">Adding a Log Entry for an Adjustment Upload Request</a> on page 1150

## Cancelling an Adjustment Data File

There might be situations when incorrect adjustment data file is uploaded in the system. In such case, the system provides you with an ability to cancel the file. However, note that you can cancel an adjustment data file only when the adjustment upload request is in the **Pending** status.

### Prerequisites



To cancel an adjustment data file, you should have:

- Cancellation reasons defined in the application

**Note:** While cancelling an adjustment data file, you need to specify the reason why you want to cancel the adjustment data file. You can select the appropriate cancellation reason only when you have defined the reasons for the **Cancelled** status of the **C1-ADJUPLD** business object in the **Status Reason** screen.

### **Procedure**

To cancel an adjustment data file:

1. Search for the adjustment upload request (which is created while uploading the file that you want to cancel) in the **Adjustment Upload Request** screen.
2. In the **Search Results** section, click the link in the **Upload Request Information** column corresponding to the adjustment data file that you want to cancel.

The **Adjustment Upload Request** screen appears. It contains the following two tabs:

- **Main** – This tab contains the following two zones:
    - **Adjustment Upload Request** – Displays the details of the adjustment upload request.
    - **Adjustment Data Records** – Lists the adjustment records which are uploaded through the adjustment data file.
  - **Log** – This tab lists the complete trail of actions performed on the adjustment upload request.
3. Click **Cancel File** in the **Adjustment Upload Request** zone.

The **Cancellation Information** window appears. It contains the following fields:

Field Name	Field Description	Mandatory (Yes or No)
Cancellation Reason	Used to indicate the reason why you want to cancel the adjustment data file.	Yes

**Note:** The **Cancel File** button appears only when the adjustment upload request is in the **Pending** status.

4. Select the cancellation reason from the list.
5. Click **Save**.

The adjustment data file is cancelled. In addition, the status of the adjustment upload request is changed to **Cancelled**.

### **Related Topics**

For more information on...	See...
How to search for an adjustment upload request	<a href="#">Searching for an Adjustment Upload Request</a> on page 1134
<b>Adjustment Upload Request</b> zone	<a href="#">Adjustment Upload Request</a> on page 1140

## **Creating Adjustments for an Adjustment Data File**

### **Procedure**

To create adjustments for an adjustment data file:

1. Search for the adjustment upload request (which is created while uploading the file for which you want to create adjustments) in the **Adjustment Upload Request** screen.

- In the **Search Results** section, click the link in the **Upload Request Information** column corresponding to the adjustment data file for which you want to create adjustments.

The **Adjustment Upload Request** screen appears. It contains the following two tabs:

- **Main** – This tab contains the following two zones:
    - **Adjustment Upload Request** – Displays the details of the adjustment upload request.
    - **Adjustment Data Records** – Lists the adjustment records which are uploaded through the adjustment data file.
  - **Log** – This tab lists the complete trail of actions performed on the adjustment upload request.
- Click **Create Adjustment** in the **Adjustment Upload Request** zone.

The Defer algorithm attached to the upload request type using which you have uploaded the adjustment data file is triggered. If the number of records in the adjustment data file does not exceed the online record process limit (defined in the Defer algorithm), the system creates adjustments in the real time (i.e. immediately). In addition, the adjustment information string appears corresponding to each adjustment record in the **Adjustment Data Records** zone and the status of the adjustment upload request is changed to **Completed**. However, if the number of records in the adjustment data file exceeds the online record process limit, the system creates adjustments in the deferred mode and the status of the adjustment upload request is changed to **Deferred**.

**Note:**

Deferred mode means in the background when the **Upload Request Periodic Monitor (C1-UPLRQ)** batch is invoked. You can configure the **Upload Request Periodic Monitor (C1-UPLRQ)** batch such that it is executed at regular intervals. When the **Upload Request Periodic Monitor (C1-UPLRQ)** batch is invoked, the system checks whether there are any adjustment upload requests in the **Deferred** status. If there is an adjustment upload request in the **Deferred** status, the system creates adjustments for the adjustment data file. Once the adjustments are created, the adjustment information string appears corresponding to each adjustment record in the **Adjustment Data Records** zone and the status of the adjustment upload request is changed to **Completed**.

The **Create Adjustment** button appears only when:

- The adjustment upload request is in the **Pending** status.
- The approval workflow process is not configured for the upload request type using which the adjustment data file is uploaded.

### Related Topics

For more information on...	See...
How to search for an adjustment upload request	<a href="#">Searching for an Adjustment Upload Request</a> on page 1134
<b>Adjustment Upload Request</b> zone	<a href="#">Adjustment Upload Request</a> on page 1140
<b>Adjustment Data Records</b> zone	<a href="#">Adjustment Data Records</a> on page 1143

## Submitting an Adjustment Data File for Approval

### Procedure

To submit an adjustment data file for approval:

- Search for the adjustment upload request (which is created while uploading the file that you want to submit for approval) in the **Adjustment Upload Request** screen.

2. In the **Search Results** section, click the link in the **Upload Request Information** column corresponding to the adjustment data file that you want to submit for approval.

The **Adjustment Upload Request** screen appears. It contains the following two tabs:

- **Main** – This tab contains the following two zones:
  - **Adjustment Upload Request** – Displays the details of the adjustment upload request.
  - **Adjustment Data Records** – Lists the adjustment records which are uploaded through the adjustment data file.
- **Log** – This tab lists the complete trail of actions performed on the adjustment upload request.

3. Click **Submit for Approval** in the **Adjustment Upload Request** zone.

The status of the adjustment upload request is changed to **Pending for Approval**. A To Do is created using the **C1-ADJUP** To Do type. Users having a To Do role to which the **C1-ADJUP** To Do type is associated can view the To Do from the **To Do List** screen. On clicking the **Submitted Message** link corresponding to the To Do, the **Adjustment Upload Request** screen appears where you can review the records of the adjustment data file.

**Note:**

The **Submit for Approval** button appears only when:

- The adjustment upload request is in the **Pending** status.
- The approval workflow process is configured for the upload request type using which the adjustment data file is uploaded.

### Related Topics

For more information on...	See...
<b>Adjustment Upload Request</b> zone	<a href="#">Adjustment Upload Request</a> on page 1140
How to search for an adjustment upload request	<a href="#">Searching for an Adjustment Upload Request</a> on page 1134

## Approving an Adjustment Data File

### Procedure

To approve an adjustment data file:

1. Search for the adjustment upload request (which is created while uploading the file that you want to review) in the **Adjustment Upload Request** screen.
2. In the **Search Results** section, click the link in the **Upload Request Information** column corresponding to the adjustment data file that you want to review.

The **Adjustment Upload Request** screen appears. It contains the following two tabs:

- **Main** – This tab contains the following two zones:
  - **Adjustment Upload Request** – Displays the details of the adjustment upload request.
  - **Adjustment Data Records** – Lists the adjustment records which are uploaded through the adjustment data file.
- **Log** – This tab lists the complete trail of actions performed on the adjustment upload request.

3. Review the records of the adjustment data file in the **Adjustment Data Records** zone.
4. If the adjustment data file is appropriate, then click **Approve** in the **Adjustment Upload Request** zone.

The Defer algorithm attached to the upload request type using which you have uploaded the adjustment data file is triggered. If the number of records in the adjustment data file does not exceed the online record process limit (defined in the Defer algorithm), the system creates adjustments in the real time (i.e. immediately). In addition, the adjustment information string appears corresponding to each adjustment record in the **Adjustment Data Records** zone and the status of the adjustment upload request is changed to **Completed**. However, if the number of records in the adjustment data file exceeds the online record process limit, the system creates adjustments in the deferred mode and the status of the adjustment upload request is changed to **Deferred**.

**Note:**

Deferred mode means in the background when the **Upload Request Periodic Monitor (C1-UPLRQ)** batch is invoked. You can configure the **Upload Request Periodic Monitor (C1-UPLRQ)** batch such that it is executed at regular intervals. When the **Upload Request Periodic Monitor (C1-UPLRQ)** batch is invoked, the system checks whether there are any adjustment upload requests in the **Deferred** status. If there is an adjustment upload request in the **Deferred** status, the system creates adjustments for the adjustment data file. Once the adjustments are created, the adjustment information string appears corresponding to each adjustment record in the **Adjustment Data Records** zone and the status of the adjustment upload request is changed to **Completed**.

The **Approve** button appears only when:

- The adjustment upload request is in the **Pending for Approval** status.
- A user with the approval To Do role is reviewing the adjustment data file.

**Related Topics**

For more information on...	See...
How to search for an adjustment upload request	<a href="#">Searching for an Adjustment Upload Request</a> on page 1134
<b>Adjustment Upload Request</b> zone	<a href="#">Adjustment Upload Request</a> on page 1140
<b>Adjustment Data Records</b> zone	<a href="#">Adjustment Data Records</a> on page 1143

**Rejecting an Adjustment Data File****Prerequisites**

To reject an adjustment data file, you should have:

- Rejection reasons defined in the application

**Note:**

While rejecting an adjustment data file, you need to specify the reason why you want to reject the adjustment data file. You can select the appropriate rejection reason only when you have defined the reasons for the **Rejected** status of the **C1-ADJUPLD** business object in the **Status Reason** screen.

The system does not allow the submitter to approve or reject the adjustment data file.

**Procedure**

To reject an adjustment data file:

1. Search for the adjustment upload request (which is created while uploading the file that you want to review) in the **Adjustment Upload Request** screen.
2. In the **Search Results** section, click the link in the **Upload Request Information** column corresponding to the adjustment data file that you want to review.

The **Adjustment Upload Request** screen appears. It contains the following two tabs:

- **Main** – This tab contains the following two zones:
    - **Adjustment Upload Request** – Displays the details of the adjustment upload request.
    - **Adjustment Data Records** – Lists the adjustment records which are uploaded through the adjustment data file.
  - **Log** – This tab lists the complete trail of actions performed on the adjustment upload request.
3. Review the records of the adjustment data file in the **Adjustment Data Records** zone.
  4. If the adjustment data file is not appropriate, then click **Reject** in the **Adjustment Upload Request** zone.

The **Rejection Information** window appears. It contains the following fields:

Field Name	Field Description	Mandatory (Yes or No)
Rejection Reason	Used to indicate the reason why you want to reject the adjustment data file.	Yes

**Note:**

The **Reject** button appears only when:

- The adjustment upload request is in the **Pending for Approval** status.
- A user with the approval To Do role is reviewing the adjustment data file.

5. Select the rejection reason from the list.
6. Click **Save**.

The adjustment data file is rejected. In addition, the status of the adjustment upload request is changed to **Rejected**.

**Related Topics**

For more information on...	See...
<b>Adjustment Upload Request</b> zone	<a href="#">Adjustment Upload Request</a> on page 1140
<b>Adjustment Data Records</b> zone	<a href="#">Adjustment Data Records</a> on page 1143
How to search for an adjustment upload request	<a href="#">Searching for an Adjustment Upload Request</a> on page 1134

## Viewing the Log of an Adjustment Upload Request

**Procedure**

To view the log of an adjustment upload request:

1. Search for the adjustment upload request in the **Adjustment Upload Request** screen.
2. In the **Search Results** section, click the link in the **Upload Request Information** column corresponding to the adjustment upload request whose log you want to view.

The **Adjustment Upload Request** screen appears. It contains the following two tabs:

- **Main** – This tab contains the following two zones:
  - **Adjustment Upload Request** – Displays the details of the adjustment upload request.

- **Adjustment Data Records** – Lists the adjustment records which are uploaded through the adjustment data file.
  - **Log** – This tab lists the complete trail of actions performed on the adjustment upload request.
3. Click the **Log** tab.

The **Upload Request Log** zone in the **Log** tab contains the following columns:

Column Name	Column Description
Date/Time	Displays the date and time when the action was performed on the adjustment upload request.
Details	Displays the details about the action performed on the adjustment upload request.
User	Indicates the user who has performed the action on the adjustment upload request.
Log Type	Indicates the type of log.
Related Object	Indicates the object or entity which is generated when the action is performed on the adjustment upload request.
Status Reason	Indicates the reason why the adjustment upload request was rejected or cancelled.

**Note:** You can manually add a log entry for the adjustment upload request by clicking the **Add Log Entry** link in the upper right corner of the **Upload Request Log** zone.

### Related Topics

For more information on...	See...
How to search for an adjustment upload request	<a href="#">Searching for an Adjustment Upload Request</a> on page 1134
How to add a log entry for an adjustment upload request	<a href="#">Adding a Log Entry for an Adjustment Upload Request</a> on page 1150

## Adding a Log Entry for an Adjustment Upload Request

### Procedure

To add a log entry for an adjustment upload request:

1. Search for the adjustment upload request in the **Adjustment Upload Request** screen.
2. In the **Search Results** section, click the link in the **Upload Request Information** column corresponding to the adjustment upload request whose log you want to edit.

The **Adjustment Upload Request** screen appears. It contains the following two tabs:

- **Main** – This tab contains the following two zones:
  - **Adjustment Upload Request** – Displays the details of the adjustment upload request.
  - **Adjustment Data Records** – Lists the adjustment records which are uploaded through the adjustment data file.
- **Log** – This tab lists the complete trail of actions performed on the adjustment upload request.

3. Click the **Log** tab.

The **Log** tab appears.

4. Click the **Add Log Entry** link in the upper right corner of the **Upload Request Log** zone.

The **Add Request Log** window appears. It contains the following fields:

Field Name	Field Description	Mandatory (Yes or No)
Request Information	Displays information about the adjustment upload request.	Not applicable
Log Details	Used to specify additional comments on the adjustment upload request.	Yes

5. Enter the comments in the **Log Details** field.

6. Click **Save**.

The log entry is added in the **Upload Request Log** zone.

### **Related Topics**

For more information on...	See...
How to search for an adjustment upload request	<a href="#">Searching for an Adjustment Upload Request</a> on page 1134





---

# Chapter 17

---

## Payment Request

---

### Topics:

- [Prerequisites](#)
- [Payment Request \(Without Approval\) Status Transition](#)
- [Payment Request \(With Approval\) Status Transition](#)
- [Algorithms Used in C1-PaymentRequest](#)
- [Algorithms Used in C1-PaymentTransferRequest](#)
- [Payment Request Type](#)
- [Payment Request \(Used for Searching\)](#)
- [Payment Request \(Used for Viewing\)](#)
- [Payment Event Summary](#)

Oracle Revenue Management and Billing facilitates you to create and transfer payments through a payment request. While creating a payment creation or transfer request, you need to specify the payment request type using which you want to create the payment request. It is the payment request type which helps the system to determine:

- Whether to create payment transfer or payment creation request
- Whether payment events and payments must be created in real time (i.e. immediately) or in the deferred mode
- Whether payment creation or transfer instructions must be approved by the approver before freezing the payments

While creating a payment creation request, you need to specify the tender amount and match type details. However, while creating a payment transfer request, you need to specify the transfer amount and match type details. The **Payment Request** feature supports the following match types :

- By Bill Regular (Match Entity: Account)
- By Bill (Match Entity: Bill)
- By Bill Weighted (Match Entity: Account)
- By Bill Segments (Match Entity: Account)
- By Suspense Contract (Match Entity: Account)
- By Settlement ID (Match Entity: Account)

You can specify multiple match types along with the entity (such as account or bill) in the payment request. Depending on the match type and match entity selected, the entities (such as unpaid bills, bill segments, or contracts) of the account are considered against which you can match the tender or transfer (payment) amount. Once you update the payment amount against the required entities, you can distribute the tender or payment amount.

On distributing the tender amount, the payment event, payments, payment segments, and payment tender are created. The payments are created in the **Freezable** status. If any error occurs while creating a payment, the payment is created in the **Error** status. If all payments of a payment event are in the **Freezable** status, the status of the payment event is set to **Balanced**. However, if any payment of a payment event is in the **Error** status, the status of the payment event is set to **Unbalanced**. On distributing the payment amount (during transfer), the new payments are created in the **Freezable** status. If any error occurs while creating a new payment, the payment is created in the **Error** status. The status of the payment event is set to **Unbalanced**. The old payments in the payment event that you want to transfer remains in the **Frozen** or **Error** status.

The system allows you to view the pay segments of a payment and edit the pay segment amount, if required. You can edit the pay segment amount before submitting the payment request for approval or before freezing the payments. If the approval is not required for the payment request, you can directly freeze the payments created through the payment request. However, if the approval is required for the payment request, you need to submit the payment request for approval. Based on the observations, the approver might approve or reject the payment request. On approving a payment creation request or freezing the payments, the status of the payments is changed from **Freezable** to **Frozen**. However, on approving a payment transfer request or freezing the payments, the system does the following:

- Changes the status of the old payments which are in the **Frozen** status to **Cancelled**
- Deletes the old payments which are in the **Error** status
- Changes the status of the new payments which are in the **Freezable** status to **Frozen**
- Changes the status of the payment event to **Balanced** when there are no payments in the **Error** status

On rejecting a payment creation request, the payment event, payments, payment segments, and payment tender which are created through the payment creation request are deleted. However, on rejecting a payment transfer request, the new payments which are created through the payment transfer request are deleted.

During the payment request process, a payment creation or transfer request goes through various statuses in its lifecycle. For more information about the payment request statuses, see [Payment Request \(Without Approval\) Status Transition](#) on page 1156 and [Payment Request \(With Approval\) Status Transition](#) on page 1157.

Note that the lifecycle of a payment creation and transfer requests is driven by the respective business object using which the payment creation and transfer requests are created. The **C1-PaymentRequest** and **C1-PaymentTransferRequest** business objects are shipped with the product. The payment request feature explained in this document is articulated based on the lifecycle and logic defined in the **C1-PaymentRequest** and **C1-PaymentTransferRequest** business objects.

For more information on how to setup the payment request process, see [Prerequisites](#) on page 1155.

## Prerequisites

To setup the payment request process, you need to do the following:

- Define the following match types:

Match Type	Description	Payment Distribution Override Algorithm	Manual Distribution Algorithm	Entity Type	Match Type Search Zone	Entity Flag
BILLR	By Bill Regular	C1-PDOV-PYBL	C1-MD-BILL	Account	C1_ACCTSRCH	Bill
BILLW	By Bill Weighted	C1-PDOV-WTBS	C1-MD-BILL	Account	C1_ACCTSRCH	Bill
BILL-WO	By Bill Weighted Outstanding Amount	C1-PDOV-WTOA		Account	C1_ACCT_SRCH	Bill
BILLSEG	By Bill Segment	C1-PDOV-PYBS	C1-MD-BSEG	Account	C1_ACCTSRCH	Bill Segment
BYSATY	By Suspense Contract	C1-PDOV-SATY	C1-MD-ONSA	Account	C1_ACCTSRCH	Contract
SETT-ID	By Settlement ID	C1-PDOV-PYSL	C1-MD-SID	Account	C1_ACCTSRCH	Settlement
BYBILL	By Bill	C1-PDOV-PYBL or C1-PDOV-WTBS	C1-MDBYBILL	Bill	CI_BILL	Bill
BILL-BS	By Bill - Pay By Bill Segment Oldest	C1-PDOV-BSDT		Account	C1_ACCT_SRCH	Bill

**Note:** The **C1-PDOV-BSDT** algorithm for the bill match type **BILL-BS** is used to distribute the amount among the bill segments of the bill in the order of bill segment start date.

**Note:** The **C1-PDOV-WTOA** algorithm for the bill match type **BILL-WOA** performs the bill weighted calculation based on the unpaid amount on the bill segment.

- Create a defer algorithm using the **C1-PAY-COUNT** algorithm type
- Define the required payment request types in the system
- Define the required characteristic types where the characteristic entity is set to **Payment Request Type**
- Define the required characteristic types where the characteristic entity is set to **Payment Tender**
- Define rejected status reasons for the **C1-PaymentRequest** business object
- Define rejected status reasons for the **C1-PaymentTransferRequest** business object
- Define payment cancelation or transfer reasons through the **Payment Cancel Reason** screen

- Assign the **C1-PAYRQ** To Do type to a To Do role whose users must receive To Do generated while submitting a payment request for approval
- Set the **Payment Portal Configuration (C1-PAYPORTAL)** feature configuration
- Set the **Payment Request-Sort Distribution data (C1-PYREQSRT)** feature configuration
- Set the batch control type of the **Payment Request Periodic Monitor (C1-PAYRQ)** batch to **Timed** and define the following attributes:
  - Time Interval
  - Timer Active
  - User ID
  - Batch Language
  - Email Address

### **Related Topics**

<b>For more information on...</b>	<b>See...</b>
How to set the C1-PAYPORTAL feature configuration	<a href="#">Setting the C1-PAYPORTAL Feature Configuration</a> on page 2918
How to set the C1-PYREQSRT feature configuration	<a href="#">Setting the C1-PYREQSRT Feature Configuration</a> on page 2925

## **Payment Request (Without Approval) Status Transition**

---

The following figure graphically indicates how a payment creation or transfer request moves from one status to another when the approval workflow is off:

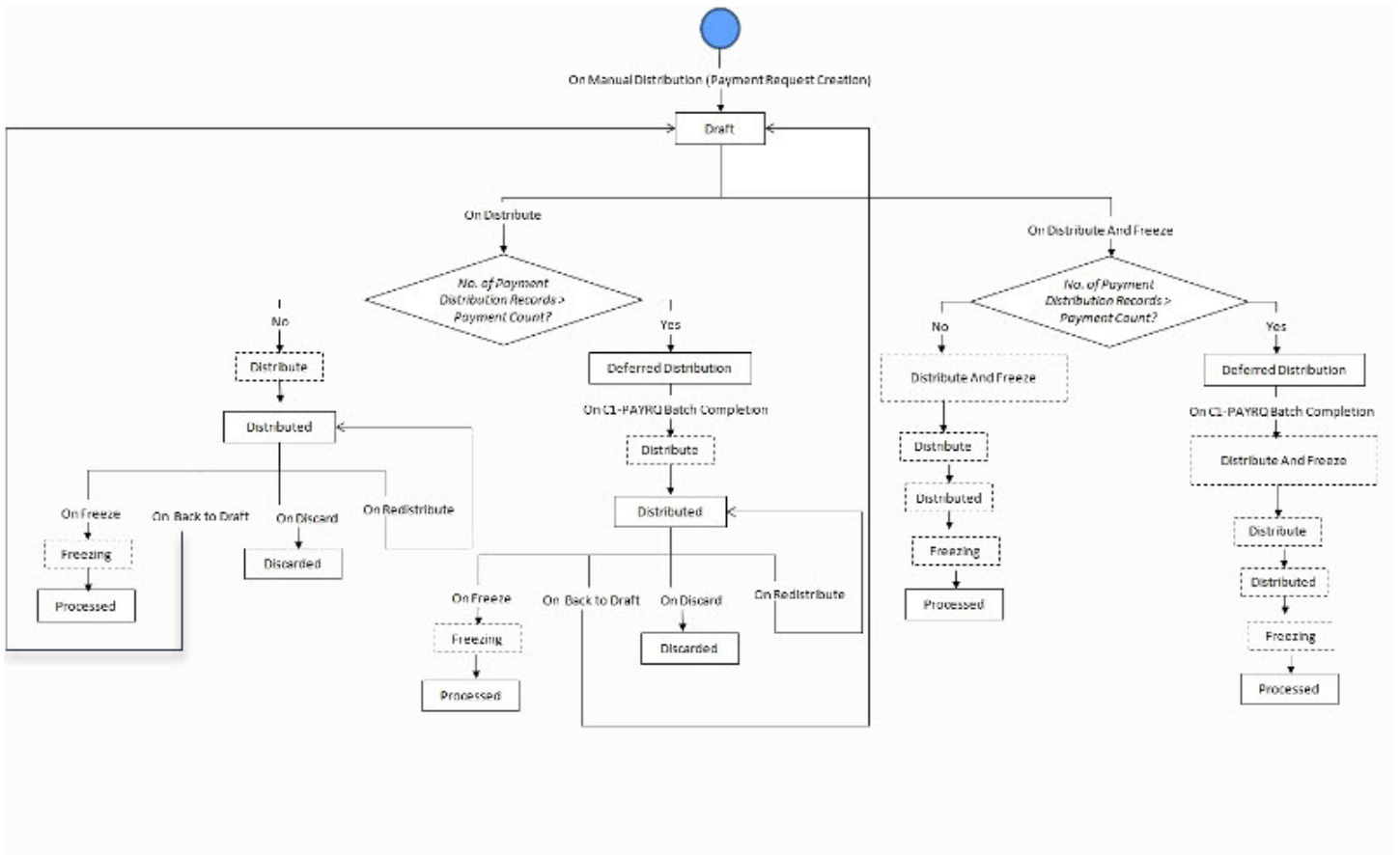

## Payment Request (With Approval) Status Transition

The following figure graphically indicates how a payment creation or transfer request moves from one status to another when approval workflow is on:

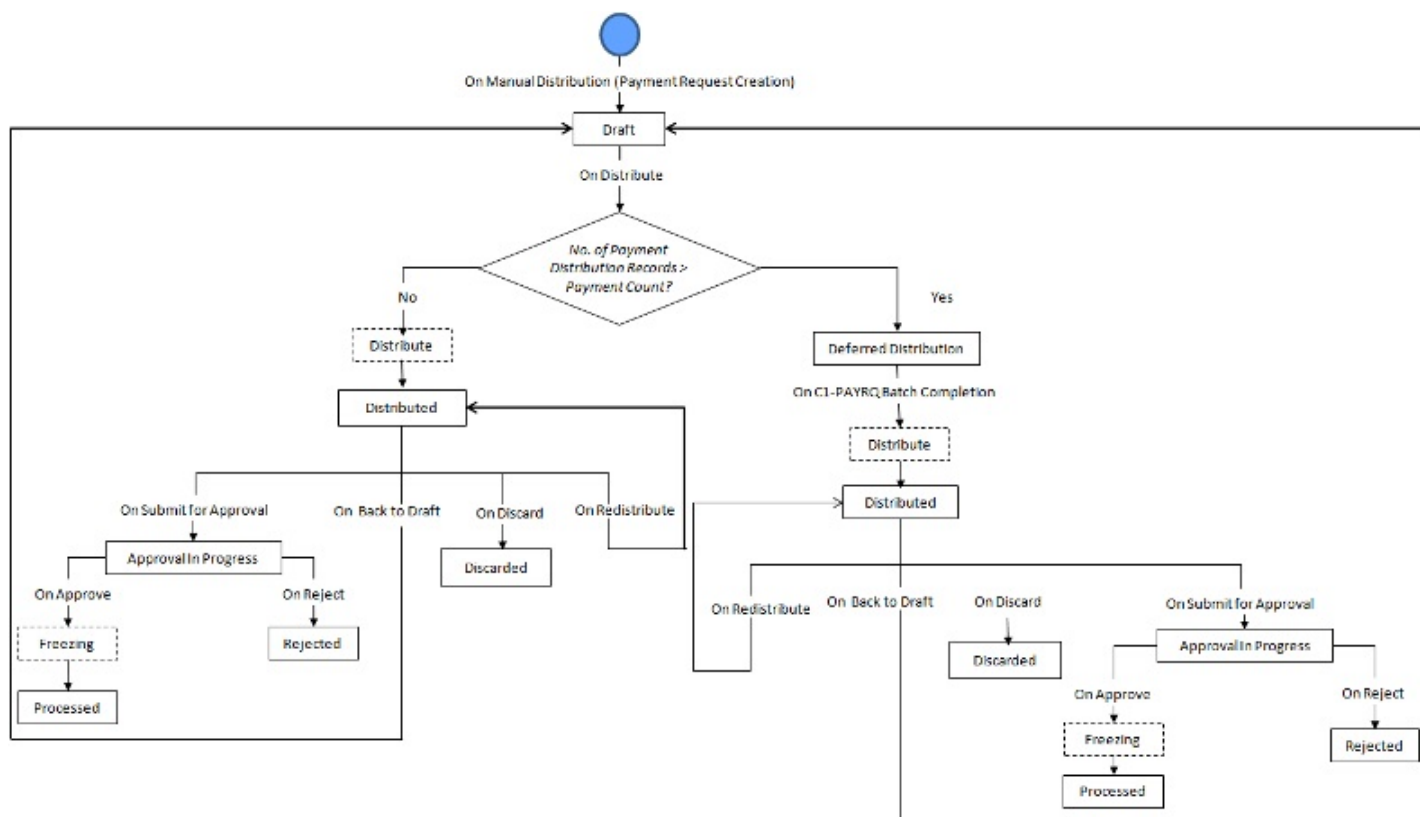

## Algorithms Used in C1-PaymentRequest

The following table lists the algorithms which are attached to the **C1-PaymentRequest** business object:

System Event	Algorithm	Algorithm Type	Description
Information	C1-PAYRQ-INF	C1-PAYRQ-INF	This algorithm generates the payment request information string which appears throughout the application. This algorithm concatenates the following fields: <ul style="list-style-type: none"> <li>• Payment Request Type Description</li> <li>• Payment Request Status Description</li> <li>• Payment Request ID</li> </ul>
Post-Processing	C1-PAYREQPOS	C1-PAYREQPOS	This algorithm invokes the manual distribution algorithm of the match types that are newly added while editing a payment request. It also deletes the respective match type entities from the <b>C1_PAY_DISTRIBUTION</b> table when you remove a match type while editing a payment request.

System Event	Algorithm	Algorithm Type	Description
Validation	C1-PAYREQVAL	C1-PAYREQVAL	<p>This algorithm checks whether the mandatory data (such as payment date, payor account, tender type, tender amount, currency, match type, and match entity) is specified while creating a payment request. It also checks whether auto pay source, auto pay route type, and account number are specified when you select a tender type where the <b>Generate Auto Pay</b> option is selected. This algorithm is triggered when you click the <b>Manual Distribution</b> button.</p> <div style="border: 1px solid black; padding: 5px;"> <p><b>Note:</b> You do not specify the tender and auto pay details while creating a payment transfer request.</p> </div>

The following table lists the algorithms which are used in the lifecycle of the **C1-PaymentRequest** business object:

Status	System Event	Algorithm	Algorithm Type	Description
Draft	Enter	C1-PAY-DFT	C1-PAY-DFT	This algorithm invokes the manual distribution algorithm of the match types that you have selected while creating a payment request.
Draft	Exit	C1-PAYDFTEXT	C1-PAYDFTEXT	This algorithm checks whether the sum of the distributed payment amount is equal to the tender or transfer amount. This algorithm is triggered when you click the <b>Distribute</b> button.
Approval In Progress	Enter	C1-PAY-PFA	C1-PAY-PFA	This algorithm creates the To Do using the To Do type specified in the payment request type using which the payment request is created. The To Do is sent to the users with the approval To Do role specified in the payment request type.
Approval In Progress	Exit	C1-PAYPFAEXT	C1-PAYPFAEXT	This algorithm checks whether the approver is associated with the approval To Do role specified in the payment request type. It does not allow the submitter to approve or reject the payment request.
Approval In Progress	Exit	F1-TODOCOMPL	F1-TODOCOMPL	This algorithm type completes To Do entries that are linked to an object when the object exits a given state. The system finds all open To Do entries with drill keys for the current business object's primary key, and completes them, unless the To Do entry's type has been configured with an Exclude To Do Type Characteristic Type indicating that it should not be automatically completed.

Status	System Event	Algorithm	Algorithm Type	Description
Approved	Enter	C1-PAY-APP	C1-PAY-APP	This algorithm changes the status of the payment request to <b>Freezing</b> when the approver clicks the <b>Approve</b> button.
Distribute	Enter	C1-PAY-DIST	C1-PAY-DIST	This algorithm invokes the defer algorithm specified in the payment request type using which the payment request is created. The defer algorithm checks whether the tender or transfer amount must be distributed in the real time (i.e. immediately) or in the deferred mode. If the tender or transfer amount must be distributed in the real time, the status of the payment request is changed to <b>Distributed</b> . However., if the tender or transfer amount must be distributed in the deferred mode, the status of the payment request is changed to <b>Deferred Distribution</b> .
Deferred Distribution	Monitor	C1-PAY-MONT	C1-PAY-MONT	This algorithm is invoked from the <b>Payment Request Periodic Monitor (C1-PAYRQ)</b> batch. It changes the status of the payment request from <b>Deferred Distribution</b> to <b>Distributed</b> .
Distributed	Enter	C1-PAYCREATE	C1-PAYCREATE	This algorithm creates the payment event, payments, payment segments, and payment tender. A payment is created for each record in the <b>C1_PAY_DISTRIBUTION</b> table where the payment amount is greater than or less than zero. The status of the payments is set to <b>Freezable</b> . If any error occurs while creating a payment, the status of the payment is set to <b>Error</b> . The payment event ID is updated corresponding to the payment request in the <b>C1_PAY_REQ</b> table. Finally, the status of the payment request is changed to <b>Distributed</b> .
Distributed	Exit	C1-FRZ-VALID	C1-FRZ-VALID	This algorithm is triggered when you click the <b>Submit for Approval</b> or <b>Freeze</b> button. It checks whether the sum of payment segment amount is equal to the payment amount for each payment.



Status	System Event	Algorithm	Algorithm Type	Description
Distributed	Exit	F1-TODOCOMPL	F1-TODOCOMPL	This algorithm completes To Do entries that are linked to an object when the object exits a given state. The system finds all open To Do entries with drill keys for the current business object's primary key, and completes them, unless the To Do entry's type has been configured with an Exclude To Do Type Characteristic Type indicating that it should not be automatically completed.
Freezing	Enter	C1-PAY-V-FRZ	C1-PAY-V-FRZ	This algorithm validates whether payment already exists on the entity. It checks the unpaid amount of the entity.
Freezing	Enter	C1-PAY-FRZ	C1-PAY-FRZ	<p>This algorithm fetches the payment event created through the payment request. If you are freezing the payments of a payment creation request, this algorithm does the following:</p> <ul style="list-style-type: none"> <li>• Changes the status of the payments which are in the <b>Freezable</b> status to <b>Frozen</b></li> <li>• Changes the status of the payment event to <b>Balanced</b> when there are no payments in the <b>Error</b> status</li> </ul> <p>However, if you are freezing the payments of a payment transfer request, this algorithm does the following:</p> <ul style="list-style-type: none"> <li>• Changes the status of the old payments which are in the <b>Frozen</b> status to <b>Cancelled</b></li> <li>• Deletes the old payments which are in the <b>Error</b> status</li> <li>• Changes the status of the new payments which are in the <b>Freezable</b> status to <b>Frozen</b></li> <li>• Changes the status of the payment event to <b>Balanced</b> when there are no payments in the <b>Error</b> status</li> </ul>
Processed	-	-	-	-

Status	System Event	Algorithm	Algorithm Type	Description
Rejected	Enter	C1-PAY-RJT	C1-PAY-RJT	This algorithm is triggered when the approver clicks the <b>Reject</b> button. If you are rejecting a payment creation request, this algorithm deletes the payment event, payments, payment segments, and payment tender which are created through the payment creation request. However, if you are rejecting a payment transfer request, this algorithm deletes the new payments which are created through the payment transfer request.
Discarded	Enter	C1-PAY-RJT	C1-PAY-RJT	This algorithm is triggered when the approver clicks the <b>Reject</b> button. If you are rejecting a payment creation request, this algorithm deletes the payment event, payments, payment segments, and payment tender which are created through the payment creation request. However, if you are rejecting a payment transfer request, this algorithm deletes the new payments which are created through the payment transfer request.
Distribute And Freeze	Enter	C1-ISFREEZE	C1-ISFREEZE	This algorithm invokes the distribute algorithm and set Flag in the payment request clob.

## Algorithms Used in C1-PaymentTransferRequest

The following table lists the algorithms which are attached to the **C1-PaymentTransferRequest** business object:

System Event	Algorithm	Algorithm Type	Description
Information	C1-PAYRQ-INF	C1-PAYRQ-INF	This algorithm generates the payment request information string which appears throughout the application. This algorithm concatenates the following fields: <ul style="list-style-type: none"> <li>• Payment Request Type Description</li> <li>• Payment Request Status Description</li> <li>• Payment Request ID</li> </ul>
Post-Processing	C1-PAYREQPOS	C1-PAYREQPOS	This algorithm invokes the manual distribution algorithm of the match types that are newly added while editing a payment request. It also deletes the respective match type entities from the <b>C1_PAY_DISTRIBUTION</b> table when you remove a match type while editing a payment request.

System Event	Algorithm	Algorithm Type	Description
Validation	C1-PAYREQVAL	C1-PAYREQVAL	<p>This algorithm checks whether the mandatory data (such as payment date, payor account, tender type, tender amount, currency, match type, and match entity) is specified while creating a payment request. It also checks whether auto pay source, auto pay route type, and account number are specified when you select a tender type where the <b>Generate Auto Pay</b> option is selected. This algorithm is triggered when you click the <b>Manual Distribution</b> button.</p> <p><b>Note:</b> You do not specify the tender and auto pay details while creating a payment transfer request.</p>

The following table lists the algorithms which are used in the lifecycle of the **C1-PaymentTransferRequest** business object:

Status	System Event	Algorithm	Algorithm Type	Description
Draft	Enter	C1-PAY-DFT	C1-PAY-DFT	This algorithm invokes the manual distribution algorithm of the match types that you have selected while creating a payment request.
Draft	Exit	C1-PAYDFTEXT	C1-PAYDFTEXT	This algorithm checks whether the sum of the distributed payment amount is equal to the tender or transfer amount. This algorithm is triggered when you click the <b>Distribute</b> button.
Approval In Progress	Enter	C1-PAY-PFA	C1-PAY-PFA	This algorithm creates the To Do using the To Do type specified in the payment request type using which the payment request is created. The To Do is sent to the users with the approval To Do role specified in the payment request type.
Approval In Progress	Exit	C1-PAYPFAEXT	C1-PAYPFAEXT	This algorithm checks whether the approver is associated with the approval To Do role specified in the payment request type. It does not allow the submitter to approve or reject the payment request.

Status	System Event	Algorithm	Algorithm Type	Description
Approval In Progress	Exit	F1-TODOCOMPL	F1-TODOCOMPL	This algorithm type completes To Do entries that are linked to an object when the object exits a given state. The system finds all open To Do entries with drill keys for the current business object's primary key, and completes them, unless the To Do entry's type has been configured with an Exclude To Do Type Characteristic Type indicating that it should not be automatically completed.
Approved	Enter	C1-PAY-APP	C1-PAY-APP	This algorithm changes the status of the payment request to <b>Freezing</b> when the approver clicks the <b>Approve</b> button.
Distribute	Enter	C1-PAY-DIST	C1-PAY-DIST	This algorithm invokes the defer algorithm specified in the payment request type using which the payment request is created. The defer algorithm checks whether the tender or transfer amount must be distributed in the real time (i.e. immediately) or in the deferred mode. If the tender or transfer amount must be distributed in the real time, the status of the payment request is changed to <b>Distributed</b> . However., if the tender or transfer amount must be distributed in the deferred mode, the status of the payment request is changed to <b>Deferred Distribution</b> .
Deferred Distribution	Monitor	C1-PAY-MONT	C1-PAY-MONT	This algorithm is invoked from the <b>Payment Request Periodic Monitor (C1-PAYRQ)</b> batch. It changes the status of the payment request from <b>Deferred Distribution</b> to <b>Distributed</b> .

Status	System Event	Algorithm	Algorithm Type	Description
Distributed	Enter	C1-PAYTRANS	C1-PAYTRANS	This algorithm is invoked when the status of the payment transfer request is changed to <b>Distributed</b> . A payment is created for each record in the <b>C1_PAY_DISTRIBUTION</b> table where the payment amount is greater than or less than zero. The status of the new payments is set to <b>Freezable</b> . If any error occurs while creating a payment, the status of the payment is set to <b>Error</b> . The payment event ID is updated corresponding to the payment request in the <b>C1_PAY_REQ</b> table. Finally, the status of the payment request is changed to <b>Distributed</b> .
Distributed	Exit	C1-FRZ-VALID	C1-FRZ-VALID	This algorithm is triggered when you click the <b>Submit for Approval</b> or <b>Freeze</b> button. It checks whether the sum of payment segment amount is equal to the payment amount for each payment.
Distributed	Exit	F1-TODOCOMPL	F1-TODOCOMPL	This algorithm type completes To Do entries that are linked to an object when the object exits a given state. The system finds all open To Do entries with drill keys for the current business object's primary key, and completes them, unless the To Do entry's type has been configured with an Exclude To Do Type Characteristic Type indicating that it should not be automatically completed.
Freezing	Enter	C1-PAY-V-FRZ	C1-PAY-V-FRZ	This algorithm validates the payment that already exists on the entity. It checks the unpaid amount of the entity.

Status	System Event	Algorithm	Algorithm Type	Description
Freezing	Enter	C1-PAY-FRZ	C1-PAY-FRZ	<p>This algorithm fetches the payment event created through the payment request. If you are freezing the payments of a payment creation request, this algorithm does the following:</p> <ul style="list-style-type: none"> <li>• Changes the status of the payments which are in the <b>Freezable</b> status to <b>Frozen</b></li> <li>• Changes the status of the payment event to <b>Balanced</b> when there are no payments in the <b>Error</b> status</li> </ul> <p>However, if you are freezing the payments of a payment transfer request, this algorithm does the following:</p> <ul style="list-style-type: none"> <li>• Changes the status of the old payments which are in the <b>Frozen</b> status to <b>Cancelled</b></li> <li>• Deletes the old payments which are in the <b>Error</b> status</li> <li>• Changes the status of the new payments which are in the <b>Freezable</b> status to <b>Frozen</b></li> <li>• Changes the status of the payment event to <b>Balanced</b> when there are no payments in the <b>Error</b> status</li> </ul>
Processed	-	-	-	-
Rejected	Enter	C1-PAY-RJT	C1-PAY-RJT	<p>This algorithm is triggered when the approver clicks the <b>Reject</b> button. If you are rejecting a payment creation request, this algorithm deletes the payment event, payments, payment segments, and payment tender which are created through the payment creation request. However, if you are rejecting a payment transfer request, this algorithm deletes the new payments which are created through the payment transfer request.</p>

Status	System Event	Algorithm	Algorithm Type	Description
Discarded	Enter	C1-PAY-RJT	C1-PAY-RJT	This algorithm is triggered when the approver clicks the <b>Reject</b> button. If you are rejecting a payment creation request, this algorithm deletes the payment event, payments, payment segments, and payment tender which are created through the payment creation request. However, if you are rejecting a payment transfer request, this algorithm deletes the new payments which are created through the payment transfer request.
Distribute And Freeze	Enter	C1-ISFREEZE	C1-ISFREEZE	This algorithm invokes the distribute algorithm and set Flag in payment request clob.
Cancel	-	-	-	-

## Payment Request Type

Oracle Revenue Management and Billing allows you to define a payment request type using which you can create a payment request. A payment request of the specified payment request type is created when you manually distribute the tender or payment amount. It is the payment request type which helps the system to determine:



- Whether to create payment transfer or payment creation request
- Whether payment events and payments must be created in real time (i.e. immediately) or in the deferred mode
- Whether payment creation or transfer instructions must be approved by the approver before freezing payments

The **Payment Request Type** screen allows you to define, edit, copy, and delete a payment request type. This screen consists of the following zones:

- [Payment Request Type List](#) on page 1167
- [Payment Request Type](#) on page 1168

## Payment Request Type List

The **Payment Request Type List** zone lists payment request types that are already defined in the system. It contains the following columns:

Column Name	Column Description
Payment Request Type	Displays the payment request type.
Description	Displays the description of the payment request type.
Edit	On clicking the <b>Edit</b>  icon, the <b>Payment Request Type</b> screen appears where you can edit the details of the payment request type.
Duplicate	On clicking the <b>Duplicate</b>  icon, the <b>Payment Request Type</b> screen appears where you can define a payment request type using an existing payment request type.

Column Name	Column Description
Delete	<p>On clicking the <b>Delete</b> (🗑️) icon, you can delete the payment request type.</p> <p><b>Note:</b> You can delete a payment request type only when you have not created a payment request using the payment request type.</p>

On clicking the **Broadcast** (📡) icon corresponding to a payment request type, the **Payment Request Type** zone appears with the details of the respective payment request type.

### Related Topics

For more information on...	See...
How to define a payment request type	<a href="#">Defining a Payment Request Type</a> on page 1170
How to edit a payment request type	<a href="#">Editing a Payment Request Type</a> on page 1174
How to copy a payment request type	<a href="#">Copying a Payment Request Type</a> on page 1177
How to delete a payment request type	<a href="#">Deleting a Payment Request Type</a> on page 1180
How to view the details of a payment request type	<a href="#">Viewing the Payment Request Type Details</a> on page 1181

## Payment Request Type

The **Payment Request Type** zone displays the details of the payment request type. This zone contains the following sections:

- **Main** — This section provides basic information about the payment request type. It contains the following fields:

Field Name	Field Description
Payment Request Type	Displays the payment request type.
Payment Request Business Object	<p>Indicates the business object that will be used to create the payment request.</p> <p><b>Note:</b> It has a link. On clicking the link, the <b>Business Object</b> screen appears where you can view the details of the respective business object.</p>
Description	Displays the description of the payment request type.
Detailed Description	Displays additional information about the payment request type.
Status	<p>Indicates the status of the payment request type. The valid values are:</p> <ul style="list-style-type: none"> <li>• Active</li> <li>• Inactive</li> </ul>
Transfer	Indicates whether the payment request type will be used to create payment transfer or payment creation request.



Field Name	Field Description
Defer Algorithm	<p>Indicates the algorithm that will be triggered when you distribute tender or payment amount. This algorithm checks whether the number of payment distribution records in the payment request exceeds the payment count (defined in the Defer algorithm). If the number of payment distribution records in the payment request does not exceed the payment count, the system distributes tender or payment amount and accordingly creates payment event and payments in real time (i.e. immediately). However, if the number of payment distribution records in the payment request exceeds the payment count, the system distributes tender or payment amount in the deferred mode.</p> <p><b>Note:</b></p> <p>Number of payment distribution records = (Number of bill segments present in each bill fetched using the Bill Weighted, Bill Regular, and Bill match type algorithm) + (Number of bill segments fetched using the Bill Segment match type algorithm) + (Number of contracts fetched using the Suspense Contract match type algorithm) + (Number of settlements fetched using the Settlement match type algorithm)</p> <p>It has a link. On clicking the link, the <b>Algorithm</b> screen appears where you can view the details of the respective algorithm.</p>
Approval Required	Indicates whether approval is required while freezing payments of the payment requests which are created using the payment request type.
Approval To Do Type	<p>Indicates that To Do of the specified To Do type must be created when you submit the payment request for approval.</p> <p><b>Note:</b></p> <p>This field appears only when the <b>Approval Required</b> check box is selected.</p> <p>It has a link. On clicking the link, the <b>To Do Type</b> screen appears with the details of the respective To Do type.</p>
Approval To Do Role	<p>Indicates that users with the specified To Do role can only approve the payment request submitted for approval.</p> <p><b>Note:</b></p> <p>This field appears only when the <b>Approval Required</b> check box is selected.</p> <p>It has a link. On clicking the link, the <b>To Do Role</b> screen appears where you can view the details of the respective To Do role.</p>

- **Characteristics** — This section lists the characteristics defined for the payment request type. It contains the following columns:

Column Name	Column Description
Characteristic Type	Indicates the characteristic type.
Characteristic Value	Displays the value of the characteristic type.

- **Record Actions** — This section contains the following buttons:

Button Name	Button Description
Edit	Used to edit the details of the payment request type.

Button Name	Button Description
Delete	Used to delete the payment request type.  <b>Note:</b> You can delete a payment request type only when you have not created a payment request using the payment request type.
Duplicate	Used to create a new payment request type using an existing payment request type.

- **Record Information** — This section contains the following fields:

Field Name	Field Description
Business Object	Indicates the business object using which the payment request type is created. In addition, a context menu appears corresponding to this field which helps in navigating to other screens in the application.  <b>Note:</b> It has a link. On clicking the link, the <b>Business Object</b> screen appears where you can view the details of the respective business object.

By default, the **Payment Request Type** zone does not appear in the **Payment Request Type** screen. It appears only when you click the **Broadcast**  icon corresponding to a payment request type in the **Payment Request Type List** zone.

### **Related Topics**

For more information on...	See...
How to define a payment request type	<a href="#">Defining a Payment Request Type</a> on page 1170
How to edit a payment request type	<a href="#">Editing a Payment Request Type</a> on page 1174
How to copy a payment request type	<a href="#">Copying a Payment Request Type</a> on page 1177
How to delete a payment request type	<a href="#">Deleting a Payment Request Type</a> on page 1180
How to view the details of a payment request type	<a href="#">Viewing the Payment Request Type Details</a> on page 1181

## **Defining a Payment Request Type**

### **Prerequisites**

To define a payment request type, you should have:

- Payment request business objects defined in the application
- Defer algorithm defined using the **C1-PAY-COUNT** algorithm type
- **C1-PAYRQ** To Do type assigned to a To Do role whose users must receive To Do generated while submitting a payment request for approval

### **Procedure**

To define a payment request type:

1. Click the **Admin** link in the **Application** toolbar.  
A list appears.
2. From the **Admin** menu, select **P** and then click **Payment Request Type**.  
A sub-menu appears.
3. Click the **Add** option from the **Payment Request Type** sub-menu.

The **Select Business Object** screen appears. It contains the following fields:

Field Name	Field Description	Mandatory (Yes or No)
Payment Request Type Business Object	Used to indicate the business object that you want to use to create the payment request type.	Yes

**Tip:** Alternatively, you can access the **Select Business Object** screen by clicking the **Add** button in the **Page Title** area of the **Payment Request Type** screen.

**Note:** The **Select Business Object** screen appears only when there are multiple payment request type business objects defined in the application. If there is only one payment request type business object defined in the application, the **Payment Request Type** screen appears.

4. Select the required payment request type business object from the respective field.
5. Click **OK**.

The **Payment Request Type** screen appears. It contains the following sections:

- **Main** - Used to specify basic details about the payment request type.
- **Characteristics** - Used to define characteristics for the payment request type.

The **Main** section contains the following fields:

Field Name	Field Description	Mandatory (Yes or No)
Payment Request Type	Used to specify the payment request type.	Yes
Business Object	Indicates the payment request type business object used while defining the payment request type.	Not applicable
Payment Request Business Object	Used to indicate the business object that you want to use while creating the payment request.	Yes
Description	Used to specify the description for the payment request type.	Yes
Detailed Description	Used to specify additional information about the payment request type.	No
Status	Used to indicate the status of the payment request type. The valid values are: <ul style="list-style-type: none"> <li>• Active</li> <li>• Inactive</li> </ul>	Yes
Transfer	Used to indicate whether the payment request type will be used to create payment transfer or payment creation request.	No

Field Name	Field Description	Mandatory (Yes or No)
Defer Algorithm	<p>Used to attach an algorithm that will be triggered when you distribute tender or payment amount. This algorithm checks whether the number of payment distribution records in the payment request exceeds the payment count (defined in the Defer algorithm). If the number of payment distribution records in the payment request does not exceed the payment count, the system distributes tender or payment amount and accordingly creates payment event and payments in real time (i.e. immediately). However, if the number of payment distribution records in the payment request exceeds the payment count, the system distributes tender or payment amount in the deferred mode.</p> <div data-bbox="505 642 1092 1367" style="border: 1px solid black; padding: 5px;"> <p><b>Note:</b></p> <p>Number of payment distribution records = (Number of bill segments present in each bill fetched using the Bill Weighted, Bill Regular, and Bill match type algorithm) + (Number of bill segments fetched using the Bill Segment match type algorithm) + (Number of contracts fetched using the Suspense Contract match type algorithm) + (Number of settlements fetched using the Settlement match type algorithm)</p> <p>Deferred mode means in the background when the <b>Payment Request Periodic Monitor (C1-PAYRQ)</b> batch is invoked. You can configure the <b>Payment Request Periodic Monitor (C1-PAYRQ)</b> batch such that it is executed at regular intervals. When the <b>Payment Request Periodic Monitor (C1-PAYRQ)</b> batch is invoked, the system checks whether there are any payment requests in the <b>Deferred Distribution</b> status. If there is a payment request in the <b>Deferred Distribution</b> status, the system distributes tender or payment amount and accordingly creates payment event and payments.</p> </div> <div data-bbox="505 1367 1092 1581" style="border: 1px solid black; padding: 5px;"> <p><b>Note:</b></p> <p>The <b>Search</b>  icon appears corresponding to this field. On clicking the <b>Search</b> icon, the <b>Algorithm Search</b> window appears.</p> </div>	Yes
Approval Required	Used to indicate whether approval is required while freezing payments of the payment requests which are created using the payment request type.	No
Approval To Do Type	<p>Used to indicate that To Do of the specified To Do type must be created when you submit the payment request for approval.</p> <div data-bbox="505 1835 1092 1919" style="border: 1px solid black; padding: 5px;"> <p><b>Note:</b> This field appears only when the <b>Approval Required</b> check box is selected.</p> </div>	<p>Yes (Conditional)</p> <div data-bbox="1112 1772 1468 1885" style="border: 1px solid black; padding: 5px;"> <p><b>Note:</b> This field is required when the <b>Approval Required</b> check box is selected.</p> </div>

Field Name	Field Description	Mandatory (Yes or No)
Approval To Do Role	Used to indicate that users with the specified To Do role can only approve the payment request submitted for approval.  <b>Note:</b> This field appears only when the <b>Approval Required</b> check box is selected.	Yes (Conditional)  <b>Note:</b> This field is required when the <b>Approval Required</b> check box is selected.

- Enter the required details.

**Note:** You can search for an algorithm and To Do type by clicking the **Search**  icon corresponding to the respective field.

- Define characteristics for the payment request type, if required.
- Click **Save**.

The payment request type is defined.

### Related Topics

For more information on...	See...
<b>Payment Request Type</b> screen	<a href="#">Payment Request Type</a> on page 1167
<b>Payment Request Type List</b> zone	<a href="#">Payment Request Type List</a> on page 1167
How to define characteristics for a payment request type	<a href="#">Defining Characteristics for a Payment Request Type</a> on page 1173

## Defining Characteristics for a Payment Request Type

### Prerequisites

To define characteristics for a payment request type, you should have:

- Characteristic types defined in the application (where the characteristic entity is set to **Payment Request Type**)

### Procedure

To define characteristics for a payment request type:

- Ensure that the **Characteristics** section is expanded when you are defining, editing, or copying a payment request type.

The **Characteristics** section contains the following fields:

Field Name	Field Description	Mandatory (Yes or No)
Characteristic Type	Used to indicate the characteristic type.  <b>Note:</b> The list includes only those characteristic types where the characteristic entity is set to <b>Payment Request Type</b> .	Yes (Conditional)  <b>Note:</b> This field is required when you are defining a characteristic for the payment request type.

Field Name	Field Description	Mandatory (Yes or No)
Characteristic Value	Used to specify the value for the characteristic type.  <b>Note:</b> On specifying the value for a predefined characteristic type, the description of the characteristic value appears corresponding to the <b>Characteristic Value</b> field.	Yes (Conditional)  <b>Note:</b> This field is required when you are defining a characteristic for the payment request type.

- Enter the required details.

**Note:** If you select a predefined characteristic type, the **Search**  icon appears corresponding to the **Characteristic Value** field. On clicking the **Search** icon, you can search for a predefined characteristic value.

- If you want to define more than one characteristic for the payment request type, click the **Add**  icon and then repeat step 2.

**Note:** However, if you want to remove a characteristic from the payment request type, click the **Delete**  icon corresponding to the characteristic.

### Related Topics

For more information on...	See...
How to define a payment request type	<a href="#">Defining a Payment Request Type</a> on page 1170
How to edit a payment request type	<a href="#">Editing a Payment Request Type</a> on page 1174
How to copy a payment request type	<a href="#">Copying a Payment Request Type</a> on page 1177

## Editing a Payment Request Type

### Prerequisites

To edit a payment request type, you should have:

- Payment request business objects defined in the application
- Defer algorithm defined using the **C1-PAY-COUNT** algorithm type
- C1-PAYRQ** To Do type assigned to a To Do role whose users must receive To Do generated while submitting a payment request for approval

### Procedure

To edit a payment request type:

- Click the **Admin** link in the **Application** toolbar.  
A list appears.
- From the **Admin** menu, select **P** and then click **Payment Request Type**.  
A sub-menu appears.
- Click the **Search** option from the **Payment Request Type** sub-menu.  
The **Payment Request Type** screen appears.

4. In the **Payment Request Type List** zone, click the **Edit** (✎) icon in the **Edit** column corresponding to the payment request type whose details you want to edit.

The **Payment Request Type** screen appears. It contains the following sections:

- **Main** - Used to specify basic details about the payment request type.
- **Characteristics** - Used to define characteristics for the payment request type.

The **Main** section contains the following fields:

Field Name	Field Description	Mandatory (Yes or No)
Payment Request Type	Displays the payment request type.	Not applicable
Business Object	Indicates the payment request type business object used while defining the payment request type.	Not applicable
Payment Request Business Object	Used to indicate the business object that you want to use while creating the payment request.	Yes
Description	Used to specify the description for the payment request type.	Yes
Detailed Description	Used to specify additional information about the payment request type.	No
Status	Used to indicate the status of the payment request type. The valid values are: <ul style="list-style-type: none"> <li>• Active</li> <li>• Inactive</li> </ul>	Yes
Transfer	Used to indicate whether the payment request type will be used to create payment transfer or payment creation request.	No

Field Name	Field Description	Mandatory (Yes or No)
Defer Algorithm	<p>Used to attach an algorithm that will be triggered when you distribute tender or payment amount. This algorithm checks whether the number of payment distribution records in the payment request exceeds the payment count (defined in the Defer algorithm). If the number of payment distribution records in the payment request does not exceed the payment count, the system distributes tender or payment amount and accordingly creates payment event and payments in real time (i.e. immediately). However, if the number of payment distribution records in the payment request exceeds the payment count, the system distributes tender or payment amount in the deferred mode.</p> <div data-bbox="509 638 1092 688" style="border: 1px solid black; padding: 2px;"> <p><b>Note:</b></p> </div> <p>Number of payment distribution records = (Number of bill segments present in each bill fetched using the Bill Weighted, Bill Regular, and Bill match type algorithm) + (Number of bill segments fetched using the Bill Segment match type algorithm) + (Number of contracts fetched using the Suspense Contract match type algorithm) + (Number of settlements fetched using the Settlement match type algorithm)</p> <p>Deferred mode means in the background when the <b>Payment Request Periodic Monitor (C1-PAYRQ)</b> batch is invoked. You can configure the <b>Payment Request Periodic Monitor (C1-PAYRQ)</b> batch such that it is executed at regular intervals. When the <b>Payment Request Periodic Monitor (C1-PAYRQ)</b> batch is invoked, the system checks whether there are any payment requests in the <b>Deferred Distribution</b> status. If there is a payment request in the <b>Deferred Distribution</b> status, the system distributes tender or payment amount and accordingly creates payment event and payments.</p> <div data-bbox="509 1367 1092 1417" style="border: 1px solid black; padding: 2px;"> <p><b>Note:</b></p> </div> <p>The <b>Search</b>  icon appears corresponding to this field. On clicking the <b>Search</b> icon, the <b>Algorithm Search</b> window appears.</p>	Yes
Approval Required	Used to indicate whether approval is required while freezing payments of the payment requests which are created using the payment request type.	No
Approval To Do Type	<p>Used to indicate that To Do of the specified To Do type must be created when you submit the payment request for approval.</p> <div data-bbox="509 1835 1092 1913" style="border: 1px solid black; padding: 2px;"> <p><b>Note:</b> This field appears only when the <b>Approval Required</b> check box is selected.</p> </div>	<p>Yes (Conditional)</p> <div data-bbox="1117 1772 1466 1885" style="border: 1px solid black; padding: 2px;"> <p><b>Note:</b> This field is required when the <b>Approval Required</b> check box is selected.</p> </div>



Field Name	Field Description	Mandatory (Yes or No)
Approval To Do Role	Used to indicate that users with the specified To Do role can only approve the payment request submitted for approval.  <b>Note:</b> This field appears only when the <b>Approval Required</b> check box is selected.	Yes (Conditional)  <b>Note:</b> This field is required when the <b>Approval Required</b> check box is selected.

**Tip:** Alternatively, you can click the **Edit** button in the **Payment Request Type** zone to edit the details of the payment request type.

5. Modify the required details.

**Note:** You can search for an algorithm and To Do type by clicking the **Search**  icon corresponding to the respective field.

6. Define, edit, or remove characteristics from the payment request type, if required.
7. Click **Save**.

The changes made to the payment request type are saved.

### Related Topics

For more information on...	See...
<b>Payment Request Type</b> screen	<a href="#">Payment Request Type</a> on page 1167
<b>Payment Request Type List</b> zone	<a href="#">Payment Request Type List</a> on page 1167
<b>Payment Request Type</b> zone	<a href="#">Payment Request Type</a> on page 1168
How to define characteristics for a payment request type	<a href="#">Defining Characteristics for a Payment Request Type</a> on page 1173

## Copying a Payment Request Type

Instead of creating a payment request type from scratch, you can create a new payment request type using an existing payment request type. This is possible through copying a payment request type. On copying a payment request type, the details including the characteristics are copied to the new payment request type. You can then edit the details, if required.

### Prerequisites

To copy a payment request type, you should have:

- Payment request type (whose copy you want to create) defined in the application
- Payment request business objects defined in the application
- Defer algorithm defined using the **C1-PAY-COUNT** algorithm type
- **C1-PAYRQ** To Do type assigned to a To Do role whose users must receive To Do generated while submitting a payment request for approval

### Procedure

To copy a payment request type:

1. Click the **Admin** link in the **Application** toolbar.  
A list appears.
2. From the **Admin** menu, select **P** and then click **Payment Request Type**.

A sub-menu appears.

3. Click the **Search** option from the **Payment Request Type** sub-menu.

The **Payment Request Type** screen appears.

4. In the **Payment Request Type List** zone, click the **Duplicate**  icon in the **Duplicate** column corresponding to the payment request type whose copy you want to create.

The **Payment Request Type** screen appears. It contains the following sections:

- **Main** - Used to specify basic details about the payment request type.
- **Characteristics** - Used to define characteristics for the payment request type.

The **Main** section contains the following fields:

Field Name	Field Description	Mandatory (Yes or No)
Payment Request Type	Used to specify the payment request type.	Yes
Business Object	Indicates the payment request type business object used while defining the payment request type.	Not applicable
Payment Request Business Object	Used to indicate the business object that you want to use while creating the payment request.	Yes
Description	Used to specify the description for the payment request type.	Yes
Detailed Description	Used to specify additional information about the payment request type.	No
Status	Used to indicate the status of the payment request type. The valid values are: <ul style="list-style-type: none"> <li>• Active</li> <li>• Inactive</li> </ul>	Yes
Transfer	Used to indicate whether the payment request type will be used to create payment transfer or payment creation request.	No

Field Name	Field Description	Mandatory (Yes or No)
Defer Algorithm	<p>Used to attach an algorithm that will be triggered when you distribute tender or payment amount. This algorithm checks whether the number of payment distribution records in the payment request exceeds the payment count (defined in the Defer algorithm). If the number of payment distribution records in the payment request does not exceed the payment count, the system distributes tender or payment amount and accordingly creates payment event and payments in real time (i.e. immediately). However, if the number of payment distribution records in the payment request exceeds the payment count, the system distributes tender or payment amount in the deferred mode.</p> <div data-bbox="516 642 1092 688" style="border: 1px solid black; padding: 2px;"> <p><b>Note:</b></p> </div> <p>Number of payment distribution records = (Number of bill segments present in each bill fetched using the Bill Weighted, Bill Regular, and Bill match type algorithm) + (Number of bill segments fetched using the Bill Segment match type algorithm) + (Number of contracts fetched using the Suspense Contract match type algorithm) + (Number of settlements fetched using the Settlement match type algorithm)</p> <p>Deferred mode means in the background when the <b>Payment Request Periodic Monitor (C1-PAYRQ)</b> batch is invoked. You can configure the <b>Payment Request Periodic Monitor (C1-PAYRQ)</b> batch such that it is executed at regular intervals. When the <b>Payment Request Periodic Monitor (C1-PAYRQ)</b> batch is invoked, the system checks whether there are any payment requests in the <b>Deferred Distribution</b> status. If there is a payment request in the <b>Deferred Distribution</b> status, the system distributes tender or payment amount and accordingly creates payment event and payments.</p> <div data-bbox="516 1371 1092 1417" style="border: 1px solid black; padding: 2px;"> <p><b>Note:</b></p> </div> <p>The <b>Search</b>  icon appears corresponding to this field. On clicking the <b>Search</b> icon, the <b>Algorithm Search</b> window appears.</p>	Yes
Approval Required	Used to indicate whether approval is required while freezing payments of the payment requests which are created using the payment request type.	No
Approval To Do Type	<p>Used to indicate that To Do of the specified To Do type must be created when you submit the payment request for approval.</p> <div data-bbox="516 1839 1092 1913" style="border: 1px solid black; padding: 2px;"> <p><b>Note:</b> This field appears only when the <b>Approval Required</b> check box is selected.</p> </div>	<p>Yes (Conditional)</p> <div data-bbox="1112 1776 1463 1881" style="border: 1px solid black; padding: 2px;"> <p><b>Note:</b> This field is required when the <b>Approval Required</b> check box is selected.</p> </div>

Field Name	Field Description	Mandatory (Yes or No)
Approval To Do Role	Used to indicate that users with the specified To Do role can only approve the payment request submitted for approval.  <b>Note:</b> This field appears only when the <b>Approval Required</b> check box is selected.	Yes (Conditional)  <b>Note:</b> This field is required when the <b>Approval Required</b> check box is selected.

**Tip:** Alternatively, you can click the **Duplicate** button in the **Payment Request Type** zone to create a copy of the payment request type.

- Enter the required details.

**Note:** You can search for an algorithm and To Do type by clicking the **Search**  icon corresponding to the respective field.

- Define, edit, or remove characteristics from the payment request type, if required.
- Click **Save**.

The new payment request type is defined.

### **Related Topics**

For more information on...	See...
<b>Payment Request Type</b> screen	<a href="#">Payment Request Type</a> on page 1167
<b>Payment Request Type List</b> zone	<a href="#">Payment Request Type List</a> on page 1167
<b>Payment Request Type</b> zone	<a href="#">Payment Request Type</a> on page 1168
How to define characteristics for a payment request type	<a href="#">Defining Characteristics for a Payment Request Type</a> on page 1173

## **Deleting a Payment Request Type**

### **Procedure**

To delete a payment request type:

- Click the **Admin** link in the **Application** toolbar.  
A list appears.
- From the **Admin** menu, select **P** and then click **Payment Request Type**.  
A sub-menu appears.
- Click the **Search** option from the **Payment Request Type** sub-menu.  
The **Payment Request Type** screen appears.
- In the **Payment Request Type List** zone, click the **Delete**  icon in the **Delete** column corresponding to the payment request type that you want to delete.  
A message appears confirming whether you want to delete the payment request type.

**Note:** You can delete a payment request type only when you have not created a payment request using the payment request type.

**Tip:** Alternatively, you can click the **Delete** button in the **Payment Request Type** zone to delete the payment request type.

5. Click **OK**.

The payment request type is deleted.

### Related Topics

For more information on...	See...
<b>Payment Request Type</b> screen	<a href="#">Payment Request Type</a> on page 1167
<b>Payment Request Type List</b> zone	<a href="#">Payment Request Type List</a> on page 1167
<b>Payment Request Type</b> zone	<a href="#">Payment Request Type</a> on page 1168

## Viewing the Payment Request Type Details

### Procedure

To view the details of a payment request type:

1. Click the **Admin** link in the **Application** toolbar.  
A list appears.
2. From the **Admin** menu, select **P** and then click **Payment Request Type**.  
A sub-menu appears.
3. Click the **Search** option from the **Payment Request Type** sub-menu.  
The **Payment Request Type** screen appears.
4. In the **Payment Request Type List** zone, click the **Broadcast**  icon corresponding to the payment request type whose details you want to view.  
The **Payment Request Type** zone appears.
5. View the details of the payment request type in the **Payment Request Type** zone.

### Related Topics

For more information on...	See...
<b>Payment Request Type</b> screen	<a href="#">Payment Request Type</a> on page 1167
<b>Payment Request Type List</b> zone	<a href="#">Payment Request Type List</a> on page 1167
<b>Payment Request Type</b> zone	<a href="#">Payment Request Type</a> on page 1168

## Payment Request (Used for Searching)

The **Payment Request** screen allows you to search for a payment creation or transfer request using various search criteria. It also allows you to create payment creation and transfer requests. Through this screen, you can navigate to the following screens:

- [Payment Request \(Used for Viewing\)](#) on page 1186

This screen consists of the following zones:



- [Search Payment Request](#) on page 1182

## Search Payment Request

The **Search Payment Request** zone allows you to search for a payment request using various search criteria. This zone contains the following two sections:

- **Search Criteria** — The **Search Criteria** section contains the following fields:

Field Name	Field Description	Mandatory (Yes or No)
Search By	Used to indicate whether you want to search for a payment request using request or payment details. The valid values are: <ul style="list-style-type: none"> <li>• Request Details</li> <li>• Payment Details</li> </ul> <p><b>Note:</b> By default, the <b>Request Details</b> option is selected.</p>	Yes
On or Before Creation Date/Time	Used to search payment requests which are created till a particular date and time. <p><b>Note:</b> By default, the current date and time appears in this field. This field appears only when you select the <b>Request Details</b> option from the <b>Search By</b> list.</p>	No
Payment Request Status	Used to search payment requests with a particular status. The valid values are: <ul style="list-style-type: none"> <li>• Approval In Progress</li> <li>• Deferred Distribution</li> <li>• Discarded</li> <li>• Distribute And Freeze</li> <li>• Distributed</li> <li>• Draft</li> <li>• Processed</li> <li>• Rejected</li> </ul> <p><b>Note:</b> This field appears only when you select the <b>Request Details</b> option from the <b>Search By</b> list.</p>	No
Payment Request Type	Used to search payment requests which are created using a particular payment request type. <p><b>Note:</b> This field appears only when you select the <b>Request Details</b> option from the <b>Search By</b> list.</p>	No

Field Name	Field Description	Mandatory (Yes or No)
User ID	Used to search payment requests which are created by a particular user.  <b>Note:</b> This field appears only when you select the <b>Request Details</b> option from the <b>Search By</b> list.	No
Payment Request ID	Used to search a particular payment request.  <b>Note:</b> This field appears only when you select the <b>Request Details</b> option from the <b>Search By</b> list.	No
Payment Event ID	Used to search a payment request through which a payment event is created.  <b>Note:</b> This field appears only when you select the <b>Payment Details</b> option from the <b>Search By</b> list. The <b>Search</b>  icon appears corresponding to this field. On clicking the <b>Search</b> icon, the <b>Payment Event Search</b> window appears.	No
Payor Account ID	Used to search payment requests which are created for a particular payor account.  <b>Note:</b> This field appears only when you select the <b>Payment Details</b> option from the <b>Search By</b> list. The <b>Search</b>  icon appears corresponding to this field. On clicking the <b>Search</b> icon, the <b>Account Search</b> window appears.	No
Payor Name	Used to search payment requests which are created for a particular payor.  <b>Note:</b> This field appears only when you select the <b>Payment Details</b> option from the <b>Search By</b> list.	No
Payment Date	Used to search payment requests through which payments are created on a particular date.  <b>Note:</b> This field appears only when you select the <b>Payment Details</b> option from the <b>Search By</b> list.	No

**Note:** You must specify at least one search criterion while searching for a payment request.

- **Search Results** — On clicking the **Search** button, the search results appear based on the specified search criteria. The **Search Results** section contains the following columns:

Column Name	Column Description
Create Date/Time	Displays the date and time when the payment request was created in the system.
Payment Request Information	Displays information about the payment request. <b>Note:</b> It has a link. On clicking the link, the <b>Payment Request</b> screen appears where you can view the details of the respective payment request.
Status	Indicates the status of the payment request. The valid values are: <ul style="list-style-type: none"> <li>• Approval In Progress</li> <li>• Deferred Distribution</li> <li>• Distributed</li> <li>• Draft</li> <li>• Processed</li> <li>• Rejected</li> </ul>
Payment Event Information	Displays information about the payment event which is created through the payment request. <b>Note:</b> It has a link. On clicking the link, the <b>Payment Event</b> screen appears with the details of the respective payment event.
Created By	Indicates the user who has created the payment request.
Payor Account Information	Displays information about the payor's account for which the payment request is created. In addition, this column has a context menu which helps in navigating to other screens in the application. <b>Note:</b> It has a link. On clicking the link, the <b>Account</b> screen appears where you can view the details of the respective account.

### Related Topics

For more information on...	See...
How to search for a payment request	<a href="#">Searching for a Payment Request</a> on page 1184
How to create a payment request	<a href="#">Creating a Payment Creation Request</a> on page 1194
How to view the details of a payment request	<a href="#">Viewing the Payment Request Details</a> on page 1185

## Searching for a Payment Request

### Prerequisites

To search for a payment request, you should have:

- Payment request types defined in the application

### Procedure

To search for a payment request:

1. Click the **Menu** link in the **Application** toolbar.

A list appears.



- From the **Main** menu, select **Financial** and then click **Payment Request**.

A sub-menu appears.

- Click the **Search** option from the **Payment Request** sub-menu.

The **Payment Request** screen appears.

- Enter the search criteria in the **Search Payment Request** zone.

**Note:** ORMB search engine supports wildcard search, where you can substitute the percentage (%) symbol as a stand in for any word or letter in a search criteria. You can use the ‘%’ wildcard character in all input fields except the date and ID fields. The ‘%’ wildcard character is suffixed automatically at the end of the partial search criteria. Therefore, you may or may not specify the wildcard character at the end of the partial search criteria. However, you have to prefix the wildcard character manually wherever required.

- Click **Search**.

A list of payment requests that meet the search criteria appears in the **Search Results** section.

### Related Topics

For more information on...	See...
<b>Payment Request</b> screen	<a href="#">Payment Request (Used for Searching)</a> on page 1181
<b>Search Payment Request</b> zone	<a href="#">Search Payment Request</a> on page 1182

## Viewing the Payment Request Details

### Procedure

To view the details of a payment request:

- Search for the payment request in the **Payment Request** screen.
- In the **Search Results** section, click the link in the **Payment Request Information** column corresponding to the payment request whose details you want to view.

The **Payment Request** screen appears. It consists of the following tabs:

- **Main** – This tab contains the following two zones:
    - **Payment Request** – Displays the details of the payment request.
    - **Payment Distribution** – Lists the payment distribution records of the payment request.
  - **Log** – This tab lists the complete trail of actions performed on the payment request.
- View the details of the payment request in the **Payment Request** zone.
  - View the payment distribution records of the payment request in the **Payment Distribution** zone.

### Related Topics

For more information on...	See...
How to search for a payment request	<a href="#">Searching for a Payment Request</a> on page 1184
<b>Payment Request</b> screen	<a href="#">Payment Request (Used for Viewing)</a> on page 1186
<b>Payment Request</b> zone	<a href="#">Payment Request</a> on page 1186
<b>Payment Distribution</b> zone	<a href="#">Payment Distribution</a> on page 1192

## Payment Request (Used for Viewing)

---

Once you create a payment creation or transfer request, the **Payment Request** screen allows you to:

- Edit the details of a payment request
- Edit the payment amount against each entity
- Delete a payment request
- View the details of a payment request
- Distribute the tender or payment amount
- Edit the amount of a payment segment
- Freeze the payments created through a payment request
- Submit a payment request for approval before freezing payments
- Approve or reject a payment request
- View the log of a payment request
- Add a log entry for a payment request

This screen consists of the following tabs:

- **Main** – This tab contains the following two zones:
  - **Payment Request** – Displays the details of the payment request.
  - **Payment Distribution** – Lists the payment distribution records of the payment request.
- **Log** – This tab lists the complete trail of actions performed on the payment request.

### Payment Request

The **Payment Request** zone displays the details of the payment request. This zone contains the following sections:

- **Main** — This section provides basic information about the payment request. It contains the following fields:

Field Name	Field Description
Payment Request Information	Displays information about the payment request.
Payment Request Type	Indicates the payment request type using which the payment request is created.  <b>Note:</b> It has a link. On clicking the link, the <b>Payment Request Type</b> screen appears where you can view the details of the payment request type.
Payment Request Status	Indicates the status of the payment request. The valid values are: <ul style="list-style-type: none"> <li>• Approval In Progress</li> <li>• Deferred Distribution</li> <li>• Distributed</li> <li>• Draft</li> <li>• Processed</li> <li>• Rejected</li> </ul>

Field Name	Field Description
Status Reason	<p>Indicates the reason why the payment request is rejected.</p> <p><b>Note:</b> This field appears only when the payment request is in the <b>Rejected</b> status. It has a link. On clicking the link, the <b>Status Reason</b> screen appears where you can view the details of the rejected reason.</p>
Payor Account Information	<p>Displays information about the payor's account for which the payment request is created.</p> <p><b>Note:</b> This field appears only when you are viewing the details of a payment creation request. It has a link. On clicking the link, the <b>Account</b> screen appears where you can view the details of the respective account.</p>
Payment Date	Displays the date when the payment event and payments are created.
Payment Event Information	<p>Displays information about the payment event. If you are viewing the details of a payment creation request, this field displays information about the payment event which is created through the payment creation request. However, if you are viewing the details of a payment transfer request, this field displays information about the payment event whose payments you want to transfer.</p> <p><b>Note:</b> This field does not appear when the payment request is in the <b>Rejected</b> status. If you are viewing the details of a payment creation request, this field does not appear when the payment creation request is in the <b>Draft</b> status. It has a link. On clicking the link, the <b>Payment Event</b> screen appears where you can view the details of the respective payment event.</p>
Transfer Amount	<p>Displays the total payment amount which you want to transfer.</p> <p><b>Note:</b> This field appears only when you are viewing the details of a payment transfer request.</p>
Transfer Reason	<p>Indicates the reason why you want to transfer the payment amount.</p> <p><b>Note:</b> This field appears only when you are viewing the details of a payment transfer request.</p>

- **Tender Details** — This section provides details about the tender used in the payment request. This section appears only when you are viewing the details of a payment creation request. It contains the following fields:

Field Name	Field Description
Tender Type	Indicates the type of tender through which the payment was made.
Tender Amount	Displays the tender amount.

Field Name	Field Description
Currency	Indicates the currency in which the payment was made.
Check Number	Displays the check number if the payment is made through check. <b>Note:</b> This field appears only when the tender type is set to <b>Check</b> .
Auto Pay Route Type Code	Indicates when and how automatic payment request of the account is routed to a financial institution. <b>Note:</b> This field appears only when you select a tender type where the <b>Generate Auto Pay</b> check box is selected.
Schedule Extract Date	Displays the date when the automatic payment request is scheduled to be sent to a financial institution. <b>Note:</b> This field appears only when you select a tender type where the <b>Generate Auto Pay</b> check box is selected.
Auto Pay Source Code	Indicates the financial institution that receives the automatic payment request. <b>Note:</b> This field appears only when you select a tender type where the <b>Generate Auto Pay</b> check box is selected.
Distribution and Freeze Date	Displays the date when the automatic payment must be distributed and frozen in the system. <b>Note:</b> This field appears only when you select a tender type where the <b>Generate Auto Pay</b> check box is selected.
Account Number	Indicates the bank account number through which the automatic payment was made. <b>Note:</b> This field appears only when you select a tender type where the <b>Generate Auto Pay</b> check box is selected.
Expires On	Displays the date when the tender type will expire. <b>Note:</b> This field appears only when you select a tender type where the <b>Generate Auto Pay</b> check box is selected.
Name	Displays the name of the person as maintained in the financial institution's system. <b>Note:</b> This field appears only when you select a tender type where the <b>Generate Auto Pay</b> check box is selected.

Field Name	Field Description
Tender Control Information	<p>Displays information about the tender control which is created when the payment event and payments are created. In addition, a context menu appears corresponding to this field which helps in navigating to other screens in the application.</p> <p><b>Note:</b> This field appears only when the payment request is in the <b>Distributed, Approval In Progress, Processed</b> , or <b>Rejected</b> status. It has a link. On clicking the link, the <b>Tender Control</b> screen appears where you can view the details of the respective tender control.</p>
Deposit Control Information	<p>Displays information about the deposit control which is created when the payment event and payments are created. In addition, a context menu appears corresponding to this field which helps in navigating to other screens in the application.</p> <p><b>Note:</b> This field appears only when the payment request is in the <b>Distributed, Approval In Progress, Processed</b>, or <b>Rejected</b> status. It has a link. On clicking the link, the <b>Deposit Control</b> screen appears where you can view the details of the respective deposit control.</p>
Pay Tender ID	<p>Displays the payment tender ID.</p> <p><b>Note:</b> This field appears only when the payment request is in the <b>Processed</b> status.</p>
Tender Status	<p>Indicates the current status of the tender. The valid values are:</p> <ul style="list-style-type: none"> <li>Valid</li> <li>Cancelled</li> </ul> <p><b>Note:</b> This field appears only when the payment request is in the <b>Processed</b> status.</p>
MICR ID	Displays the MICR code on the payment.
Ext. Reference ID	Displays the external reference number of the payment on the payment upload interface record.
Person ID	Indicates the person's account ID mentioned in the payment upload interface record.
Name	Indicates the person mentioned in the payment upload interface record.

- **Characteristics** — This section lists the characteristics defined for the payment tender. It appears only when you are viewing the details of a payment creation request. It contains the following columns:

Column Name	Column Description
Characteristic Type	Indicates the characteristic type.
Characteristic Value	Displays the value of the characteristic type.

- **Match Types** — This section lists the match type details of the payment request. This section appears only when you are viewing the details of a payment creation request. It contains the following columns:

Column Name	Column Description
Match Type	Indicates the match type using which you want to match the payment.
Match By	Indicates the bill or account (whose entities, such as unpaid bills, unpaid bill segments, settlement IDs, or contracts) must be considered while matching the payment.

- **Payor Account Details** — This section appears only when you are viewing the details of a payment transfer request. It contains the following columns:

Column Name	Column Description
Payor Account Information	Displays information about the payor's account whose payments you want to transfer.

- **Payment Details** — This section appears only when you are viewing the details of a payment transfer request. It contains the **Show Payments** link. On clicking the link, the **Payment** screen appears where you can view the details of the payment that you want to transfer. In case, you want to transfer multiple payments, the **Payment Search** window appears with the list of payments selected for transfer. You can click the individual payment to view the details in the **Payment** screen. The **Show Payments** link does not appear when you are viewing the details of a payment transfer request which is in the **Processed** status. Instead, the following column appears in this section:

Column Name	Column Description
Payment(s)	Displays information about the payment which is cancelled.

- **Record Actions** — This section contains the following buttons:

Column Name	Column Description
Edit	Used to edit the details of the payment request. <b>Note:</b> The <b>Edit</b> button appears only when the payment request is in the <b>Draft</b> status.
Delete	Used to delete the payment request. <b>Note:</b> The <b>Delete</b> button appears only when the payment request is in the <b>Draft</b> status.
Distribute	Used to distribute the tender or payment amount. <b>Note:</b> The <b>Distribute</b> button appears only when the payment request is in the <b>Draft</b> status.
Submit for Approval	Used to submit the payment request for approval. <b>Note:</b> The <b>Submit for Approval</b> button appears only when: <ul style="list-style-type: none"> <li>• The payment request is in the <b>Distributed</b> status.</li> <li>• The <b>Approval Required</b> check box is selected in the payment request type using which the payment request is created.</li> </ul>

Column Name	Column Description
Freeze	Used to freeze the payments which are created through the payment request.  <b>Note:</b> The <b>Freeze</b> button appears only when: <ul style="list-style-type: none"> <li>The payment request is in the <b>Distributed</b> status.</li> <li>The <b>Approval Required</b> check box is not selected in the payment request type using which the payment request is created.</li> </ul>
Approve	Used to approve the payment request.  <b>Note:</b> The <b>Approve</b> button appears only when: <ul style="list-style-type: none"> <li>The payment request is in the <b>Approval In Progress</b> status.</li> <li>A user with the approval To Do role is reviewing the payment request.</li> </ul>
Reject	Used to reject the payment request.  <b>Note:</b> The <b>Reject</b> button appears only when: <ul style="list-style-type: none"> <li>The payment request is in the <b>Approval In Progress</b> status.</li> <li>A user with the approval To Do role is reviewing the payment request.</li> </ul>
Back to Draft	Used to change the status of the payment request to <b>Draft</b> .  <b>Note:</b> The <b>Back to Draft</b> button appears only when the payment request is in the <b>Distributed</b> status.
Discard	Used to discard the payment creation or transfer request.  <b>Note:</b> The <b>Discard</b> button appears only when the payment request is in the <b>Distributed</b> status.
Distribute And Freeze	Used to distribute and freeze the payments at the same time.  <b>Note:</b> the <b>Distribute And Freeze</b> button appears only when the payment request is in the <b>Draft</b> status.

- **Record Information** — This section contains the following fields:

Field Name	Field Description
Business Object	Indicates the business object using which the payment request is created. In addition, a context menu appears corresponding to this field which helps in navigating to other screens in the application.  <b>Note:</b> It has a link. On clicking the link, the <b>Business Object</b> screen appears where you can view the details of the respective business object.
Status Date/Time	Displays the date and time when the payment request status is updated
Create Date/Time	Displays the date and time when the payment request is created.

## Payment Distribution

The **Payment Distribution** zone lists the payment distribution records of the payment request. This zone contains the following columns:

Column Name	Column Description
Match Type	Indicates the match type using which the payment was matched.
Payee Account ID	Indicates the account for which the payment was made.  <b>Note:</b> It has a link. On clicking the link, the <b>Account</b> screen appears where you can view the details of the respective account.
Match Value	Indicates the entity (such as bill ID, bill segment ID, contract ID, or settlement ID) against which the payment was matched.
Match Entity	Indicates the type of entity against which the payment was matched. The valid values are: <ul style="list-style-type: none"> <li>• Bill</li> <li>• Bill Segment</li> <li>• Contract</li> <li>• Settlement</li> </ul>
Amount	Displays the entity amount. In case of contract, the entity amount would be zero.
Write Off Adjustment Amount	Indicates the amount which is either write up or down when the payment against the bill is within the tolerance limit.  <b>Note:</b> The data appears in this column only when the match type is <b>Bill Weighted</b> and the payment amount is within the underpayment or overpayment tolerance limit. This column does not appear when the payment request is in the <b>Draft</b> or <b>Rejected</b> status.
Paid Amount	Displays the amount which is already paid against the entity.  <b>Note:</b> This column appears only when the payment request is in the <b>Draft</b> or <b>Rejected</b> status.
Unpaid Amount	Displays the amount which is eligible for payment against the entity.  <b>Note:</b> This column appears only when the payment request is in the <b>Draft</b> or <b>Rejected</b> status.
Payment Amount	Displays the payment amount. If the <b>Show Default</b> check box is not selected against a match type while creating the payment request, the payment amount against the respective match type entities is set to zero. However, if the <b>Show Default</b> check box is selected against a match type while creating the payment request, the payment amount appears against the respective match type entities. The tender amount is divided among the entities in the sequence of match types (where <b>Show Default</b> check box is selected) followed by the sequence of bill, bill segment, or contract start date. You can edit the payment amount, if required.
Payment Currency	Indicates the currency in which the payment was made.



Column Name	Column Description
Payment ID	<p>Displays the payment ID.</p> <p><b>Note:</b> It has a link. On clicking the link, the <b>Payment</b> screen appears with the details of the respective payment. This column does not appear when the payment request is in the <b>Draft</b> or <b>Rejected</b> status.</p>
Payment Status	<p>Indicates the status of the payment. The valid values are:</p> <ul style="list-style-type: none"> <li>• Canceled</li> <li>• Error</li> <li>• Freezable</li> <li>• Frozen</li> <li>• Incomplete</li> </ul> <p><b>Note:</b> This column does not appear when the payment request is in the <b>Draft</b> or <b>Rejected</b> status.</p>
Error Message	<p>Indicates the reason why the payment is in the <b>Error</b> status.</p> <p><b>Note:</b> This column does not appear when the payment request is in the <b>Draft</b> or <b>Rejected</b> status.</p>
Detail	<p>On clicking the <b>Detail</b> button, the <b>Edit Payment Segment Amount</b> screen appears where you can edit the payment segment amount.</p> <p><b>Note:</b> This column does not appear when the payment request is in the <b>Draft</b> or <b>Rejected</b> status. The <b>Detail</b> button appears in the <b>Detail</b> column only when:</p> <ul style="list-style-type: none"> <li>• The payment request is in the <b>Distributed</b> or <b>Approval In Progress</b> status</li> <li>• The payment is in the <b>Freezable</b> status.</li> </ul> <p>However, a user with the approval To Do role will not be able to edit the payment segment amount.</p>
Redistribute	<p>On clicking the <b>Redistribute</b> button, you can redistribute the payment amount among the payment segments.</p> <p><b>Note:</b> This column appears only when the payment request is in the <b>Distributed</b> or <b>Distribute and Freeze</b> status. The <b>Redistribute</b> button appears in the <b>Redistribute</b> column only when:</p> <ul style="list-style-type: none"> <li>• The payment request is in the <b>Distributed</b> or <b>Approval In Progress</b> status</li> </ul>

You can edit the payment amount by clicking the **Update Payment Amount** button in the upper right corner of this zone.

### **Related Topics**

<b>For more information on...</b>	<b>See...</b>
How to edit the payment amount against each entity	<a href="#">Editing the Payment Amount</a> on page 1200

## Creating a Payment Creation Request

### Prerequisites

To create a payment creation request, you should have:

- Payment request types defined in the application (where the **Transfer** check box is not selected)

### Procedure

To create a payment creation request:

1. Click the **Menu** link in the **Application** toolbar.  
A list appears.
2. From the **Main** menu, select **Financial** and then click **Payment Request**.  
A sub-menu appears.
3. Click the **Add** option from the **Payment Request** sub-menu.

The **Select Payment Request Type** screen appears. It contains the following fields:

Field Name	Field Description	Mandatory (Yes or No)
Payment Request Type	Used to indicate the payment request type using which you want to create the payment request.  <b>Note:</b> The list includes only those payment request types where the <b>Transfer</b> check box is not selected.	Yes

**Tip:** Alternatively, you can access the **Select Payment Request Type** screen by clicking the **Add** button in the **Page Title** area of the **Payment Request** screen.

4. Select the required payment request type from the respective field.
5. Click **OK**.

The **Payment Request** screen appears. It contains the following sections:

- **Main** - Used to specify basic details about the payment request. This section contains the following fields:

Field Name	Field Description	Mandatory (Yes or No)
Payment Request Type	Indicates the payment request type using which you want to create the payment request.	Not applicable
Payor Account Information	Used to indicate the payor account for which you want to create the payment request.  <b>Note:</b> On specify the account ID, additional information about the account appears corresponding to this field.  The <b>Search</b>  icon appears corresponding to this field. On clicking the <b>Search</b> icon, the <b>Account Search</b> window appears.	Yes

Field Name	Field Description	Mandatory (Yes or No)
Payment Date	Used to specify the date when the payment was made.  <b>Note:</b> By default, the current date appears in this field.	Yes

- **Tender Details** - Used to specify the tender details in the payment request. This section contains the following fields:

Field Name	Field Description	Mandatory (Yes or No)
Tender Type	Used to indicate the type of tender through which the payment was made.	Yes
Tender Amount	Used to specify the tender amount.	Yes
Currency	Used to indicate the currency in which the payment was made.	Yes
Check Number	Used to specify the check number if the payment is made through check.	No
Auto Pay Route Type Code	Used to indicate when and how automatic payment request of the account is routed to a financial institution.  <b>Note:</b> This field appears only when you select a tender type where the <b>Generate Auto Pay</b> check box is selected.	Yes (Conditional)  <b>Note:</b> This field is required only when you select a tender type where the <b>Generate Auto Pay</b> check box is selected.
Schedule Extract Date	Displays the date when the automatic payment request is scheduled to be sent to a financial institution.  <b>Note:</b> This field appears only when you select a tender type where the <b>Generate Auto Pay</b> check box is selected.	Not applicable
Auto Pay Source Code	Used to indicate the financial institution that receives the automatic payment request.  <b>Note:</b> This field appears only when you select a tender type where the <b>Generate Auto Pay</b> check box is selected.	Yes (Conditional)  <b>Note:</b> This field is required only when you select a tender type where the <b>Generate Auto Pay</b> check box is selected.
Distribution and Freeze Date	Displays the date when the automatic payment must be distributed and frozen in the system.  <b>Note:</b> This field appears only when you select a tender type where the <b>Generate Auto Pay</b> check box is selected.	Not applicable

Field Name	Field Description	Mandatory (Yes or No)
Account Number	Used to indicate the bank account number through which the automatic payment was made.  <b>Note:</b> This field appears only when you select a tender type where the <b>Generate Auto Pay</b> check box is selected.	Yes (Conditional)  <b>Note:</b> This field is required only when you select a tender type where the <b>Generate Auto Pay</b> check box is selected.
Expires On	Used to specify the date when the tender type will expire.  <b>Note:</b> This field appears only when you select a tender type where the <b>Generate Auto Pay</b> check box is selected.	No
Name	Used to specify the name of the person as maintained in the financial institution's system.  <b>Note:</b> This field appears only when you select a tender type where the <b>Generate Auto Pay</b> check box is selected.	No
MICR ID	Used to specify the MICR code on the payment.	No
Ext. Reference ID	Used to specify the external reference number of the payment on the payment upload interface record.	No
Person ID	Used to indicate the person's account ID mentioned in the payment upload interface record.	No
Name	Used to indicate the person mentioned in the payment upload interface record.	No
Tender Control ID	<b>Note:</b> The <b>Search</b>  icon appears corresponding to this field. On clicking the <b>Search</b> icon, the <b>Tender Control Search</b> window appears.	

**Note:** If the auto pay instructions are defined for the payor account, by default, the auto pay data appears in the **Auto Pay Route Type Code**, **Auto Pay Source Code**, **Account Number**, **Expires On**, and **Name** fields.

- **Characteristics** - Used to define characteristics for the payment tender. This section contains the following fields:

Field Name	Field Description	Mandatory (Yes or No)
Characteristic Type	Used to indicate the characteristic type.  <b>Note:</b> The list includes only those characteristic types where the characteristic entity is set to <b>Payment Tender</b> .	Yes (Conditional)  <b>Note:</b> This field is required when you are defining a characteristic for the payment tender.
Characteristic Value	Used to specify the value for the characteristic type.  <b>Note:</b> On specifying the value for a predefined characteristic type, the description of the characteristic value appears corresponding to the <b>Characteristic Value</b> field.	Yes (Conditional)  <b>Note:</b> This field is required when you are defining a characteristic for the payment tender.



- **Match Types** - Used to define match types for the payment request. This section contains the following fields:

Field Name	Field Description	Mandatory (Yes or No)
Match Type	Used to indicate the match type using which you want to match the payment.	Yes
Show Default	Used to indicate whether the default payment amount should be displayed against the match type entities.  <b>Note:</b> By default, the <b>Show Default</b> check box is selected when you select the match type.	No
Entity	Indicates the match type entity. The valid values are: <ul style="list-style-type: none"> <li>• <b>Account</b> — Enables you to select the account whose unpaid bills, unpaid bill segments, settlement IDs, or contracts must be considered while matching the payment.</li> <li>• <b>Bill</b> — Enables you to select the unpaid bill against which you want to match the payment.</li> </ul> <b>Note:</b> The <b>Search</b>  icon appears corresponding to this field. On clicking the <b>Search</b> icon, the <b>Account Search</b> window appears.	Not applicable
Entity ID	Used to specify the account or bill ID depending on the match type entity.	Yes

6. Enter the required details.

**Note:**

You can search for a payor account, auto pay route type, auto pay source, and entity by clicking the **Search**  icon corresponding to the respective field.

If you want to specify more than one match type within the payment request, click the **Add**  icon in the **Match Types** section and then specify the details. However, if you want to remove a match type from the payment request, click the **Delete**  icon corresponding to the match type.

7. Define characteristics for the payment tender, if required.

8. Click **Manual Distribution**.

The payment request is created and the status of the payment request is set to **Draft**. The **Payment Request** screen appears. Depending on the match type and match entity specified while creating the payment request, the following entities are listed in the **Payment Distribution** zone:

Match Type	Match Entity	Entities
By Bill Regular	Account	Unpaid bills of the account
By Bill Weighted	Account	Unpaid bills of the account
By Bill	Bill	Unpaid bill
By Bill Segments	Account	Unpaid bill segments
By Suspense Contract	Account	Contracts of the account  <b>Note:</b> Only contracts of the contract type where the <b>Eligible for Billing</b> flag is set to <b>No</b> and <b>Special Role</b> flag is set to <b>Suspense</b> are listed in the <b>Payment Distribution</b> zone. If no contracts with this specification exist for the account, the system checks whether there is any such contract type (where the <b>Eligible for Billing</b> flag is set to <b>No</b> and <b>Special Role</b> flag is set to <b>Suspense</b> ) defined for the division to which the account belongs. If there is any such contract type defined for the division, the system creates the contract for the account using the respective contract type and the same is listed in <b>Payment Distribution</b> zone.
By Settlement	Account	Unpaid bill segments where the settlement account is stamped

If the **Show Default** check box is not selected against a match type while creating the payment request, the payment amount against the respective match type entities is set to zero. However, if the **Show Default** check box is selected against a match type, the payment amount appears against the respective match type entities. The tender amount is divided among the entities in the sequence of match types (where **Show Default** check box is selected) followed by the sequence of bill, bill segment, or contract start date. You can then edit the payment amount, if required.

**Note:**

If a payment request is already created for a payee account and is currently in progress, the system will not allow you to create another payment request for the payee account until the previous payment request is in the **Processed** or **Rejected** status.

The system does not allow you to create a payment request for a payee account when the respective match type entities (such as unpaid bills, unpaid bill segments, contracts, or settlement IDs do not exists for the payee account.

**Related Topics**

For more information on...	See...
<b>Search Payment Request</b> zone	<a href="#">Search Payment Request</a> on page 1182
How to define characteristics for a payment tender	<a href="#">Defining Characteristics for a Payment Tender</a> on page 1199
<b>Payment Request</b> screen	<a href="#">Payment Request (Used for Viewing)</a> on page 1186
<b>Payment Distribution</b> zone	<a href="#">Payment Distribution</a> on page 1192

**Defining Characteristics for a Payment Tender****Prerequisites**

To define characteristics for a payment tender, you should have:

- Characteristic types defined in the application (where the characteristic entity is set to **Payment Tender**)

**Procedure**

To define characteristics for a payment tender:

1. Ensure that the **Characteristics** section is expanded when you are defining or editing a payment request.

The **Characteristics** section contains the following fields:

Field Name	Field Description	Mandatory (Yes or No)
Characteristic Type	Used to indicate the characteristic type. <b>Note:</b> The list includes only those characteristic types where the characteristic entity is set to <b>Payment Tender</b> .	Yes (Conditional) <b>Note:</b> This field is required when you are defining a characteristic for the payment tender.
Characteristic Value	Used to specify the value for the characteristic type. <b>Note:</b> On specifying the value for a predefined characteristic type, the description of the characteristic value appears corresponding to the <b>Characteristic Value</b> field.	Yes (Conditional) <b>Note:</b> This field is required when you are defining a characteristic for the payment tender.

2. Enter the required details.

**Note:** If you select a predefined characteristic type, the **Search** (🔍) icon appears corresponding to the **Characteristic Value** field. On clicking the **Search** icon, you can search for a predefined characteristic value.

3. If you want to define more than one characteristic for the payment tender, click the **Add** (+) icon and then repeat step 2.

**Note:** However, if you want to remove a characteristic from the payment tender, click the **Delete** (🗑️) icon corresponding to the characteristic.

### Related Topics

For more information on...	See...
How to create a payment creation request	<a href="#">Creating a Payment Creation Request</a> on page 1194
How to edit a payment request	<a href="#">Editing a Payment Request</a> on page 1202

## Editing the Payment Amount

### Procedure

To edit the payment amount against each entity:

1. Search for the payment request in the **Payment Request** screen.
2. In the **Search Results** section, click the link in the **Payment Request Information** column corresponding to the payment request whose details you want to edit.

The **Payment Request** screen appears.

3. Click the **Update Payment Amount** button in the upper right corner of the **Payment Distribution** zone.

The **Edit Payment Amount** screen appears. It contains the following two sections:

- **Search Criteria** — The **Search Criteria** section allows you to filter the payment distribution records using various search criteria. It contains the following fields:

Field Name	Field Description	Mandatory (Yes or No)
Match Type	Used to search the entities which are considered using a particular match type. <b>Note:</b> By default, the <b>All</b> option is selected.	Yes
Entity ID	Used to search entities which belong to a particular account. <b>Note:</b> By default, the <b>All</b> option is selected.	Yes
Match Value	Used to search for a particular entity (such as bill, bill segment, contract, or settlement ID).	No
Sort By	Used to sort entity information as per the match type defined in the <b>C1-PYREQSRT</b> feature configuration.	No

- **Search Results** — On clicking the **Search** button, the search results are filtered based on the specified search criteria. The **Search Results** section contains the following columns:



Column Name	Column Description
Match Type	Indicates the match type using which the entity is considered.
Payee Information	Displays information about the account for which the payment was made.
Entity Information	Displays information about the entity against which the payment was matched.
Amount	Displays the entity amount. In case of contract, the entity amount would be zero.
Paid Amount	Displays the amount which is already paid against the entity.
Unpaid Amount	Displays the amount which is eligible for payment against the entity.
Payment Amount	Used to specify the payment amount.  <b>Note:</b> If the <b>Allow Overpayment</b> option type of the <b>C1-PAYPORTAL</b> feature configuration is set to <b>true</b> , you can specify the payment amount greater than the unpaid amount. In other words, you can make overpayment against an entity.
Payment Currency	Indicates the currency in which the payment was made.

In addition, the **Search Results** section contains the following fields:

Field Name	Field Description
Total Amount	Displays the tender or transfer amount.
Running Total	Displays the sum of payment amount specified against each entity.
Running Balance	Displays the difference between total amount and running total. The running balance is highlighted in the red color when the difference amount is non-zero.

**Note:** Pagination is used to display limited number of records in the **Edit Payment Amount** screen. You can change the number of records displayed per page, if required. You can use the navigation buttons, such as **First** ( << ), **Previous** ( < ), **Next** ( > ), and **Last** ( >> ) to navigate between pages. You can also select the page to which you want to navigate from the **Go To** list.

- Modify the payment amount against an entity, if required.

**Note:** The sum of payment amount should be equal to the tender or transfer (payment) amount.

- Click **Save**.

The changes made to the payment request are saved.

- Click **Close**.

The payment amount is updated in the **Payment Distribution** zone.

### Related Topics

For more information on...	See...
How to search for a payment request	<a href="#">Searching for a Payment Request</a> on page 1184
<b>Payment Request</b> screen	<a href="#">Payment Request (Used for Viewing)</a> on page 1186

<b>For more information on...</b>	<b>See...</b>
<b>Payment Distribution</b> zone	<i>Payment Distribution</i> on page 1192

## Editing a Payment Request

### Procedure

To edit a payment request:

1. Search for the payment request in the **Payment Request** screen.
2. In the **Search Results** section, click the link in the **Payment Request Information** column corresponding to the payment request whose details you want to edit.

The **Payment Request** screen appears.

3. Click the **Edit** button in the **Payment Request** zone.

The **Payment Request** screen appears. It contains the following sections:

- **Main** - Used to specify basic details about the payment request. This section contains the following fields:

Field Name	Field Description	Mandatory (Yes or No)
Payment Request Information	Displays information about the payment request.	Not applicable
Payment Request Type	Indicates the payment request type using which the payment request is created.	Not applicable
Payor Account Information	Used to indicate the payor account for which you want to create the payment request.  <div style="border: 1px solid black; padding: 5px;"> <p><b>Note:</b> On specify the account ID, additional information about the account appears corresponding to this field.</p> <p>The <b>Search</b>  icon appears corresponding to this field. On clicking the <b>Search</b> icon, the <b>Account Search</b> screen appears.</p> </div>	Yes
Payment Date	Used to specify the date when the payment was made.	Yes

- **Tender Details** - Used to specify the tender details in the payment request. This section contains the following fields:

Field Name	Field Description	Mandatory (Yes or No)
Tender Type	Used to indicate the type of tender through which the payment was made.	Yes
Tender Amount	Used to specify the tender amount.	Yes
Currency	Used to indicate the currency in which the payment was made.	Yes
Check Number	Used to specify the check number if the payment is made through check.	No

Field Name	Field Description	Mandatory (Yes or No)
Auto Pay Route Type Code	Used to indicate when and how automatic payment request of the account is routed to a financial institution.  <b>Note:</b> This field appears only when you select a tender type where the <b>Generate Auto Pay</b> check box is selected.	Yes (Conditional)  <b>Note:</b> This field is required only when you select a tender type where the <b>Generate Auto Pay</b> check box is selected.
Schedule Extract Date	Displays the date when the automatic payment request is scheduled to be sent to a financial institution.  <b>Note:</b> This field appears only when you select a tender type where the <b>Generate Auto Pay</b> check box is selected.	Not applicable
Auto Pay Source Code	Used to indicate the financial institution that receives the automatic payment request.  <b>Note:</b> This field appears only when you select a tender type where the <b>Generate Auto Pay</b> check box is selected.	Yes (Conditional)  <b>Note:</b> This field is required only when you select a tender type where the <b>Generate Auto Pay</b> check box is selected.
Distribution and Freeze Date	Displays the date when the automatic payment must be distributed and frozen in the system.  <b>Note:</b> This field appears only when you select a tender type where the <b>Generate Auto Pay</b> check box is selected.	Not applicable
Account Number	Used to indicate the bank account number through which the automatic payment was made.  <b>Note:</b> This field appears only when you select a tender type where the <b>Generate Auto Pay</b> check box is selected.	Yes (Conditional)  <b>Note:</b> This field is required only when you select a tender type where the <b>Generate Auto Pay</b> check box is selected.
Expires On	Used to specify the date when the tender type will expire.  <b>Note:</b> This field appears only when you select a tender type where the <b>Generate Auto Pay</b> check box is selected.	No
Name	Used to specify the name of the person as maintained in the financial institution's system.  <b>Note:</b> This field appears only when you select a tender type where the <b>Generate Auto Pay</b> check box is selected.	No
MICR ID	Used to specify the MICR code on the payment.	No

Field Name	Field Description	Mandatory (Yes or No)
Ext. Reference ID	Used to specify the external reference number of the payment on the payment upload interface record.	No
Person ID	Used to indicate the person's account ID mentioned in the payment upload interface record.	No
Name	Used to indicate the person mentioned in the payment upload interface record.	No

**Note:** If the auto pay instructions are defined for the payor account, by default, the auto pay data appears in the **Auto Pay Route Type Code, Auto Pay Source Code, Account Number, Expires On, and Name** fields.

- **Characteristics** - Used to define characteristics for the payment tender. This section contains the following fields:

Field Name	Field Description	Mandatory (Yes or No)
Characteristic Type	Used to indicate the characteristic type. <b>Note:</b> The list includes only those characteristic types where the characteristic entity is set to <b>Payment Tender</b> .	Yes (Conditional) <b>Note:</b> This field is required when you are defining a characteristic for the payment tender.
Characteristic Value	Used to specify the value for the characteristic type. <b>Note:</b> On specifying the value for a predefined characteristic type, the description of the characteristic value appears corresponding to the <b>Characteristic Value</b> field.	Yes (Conditional) <b>Note:</b> This field is required when you are defining a characteristic for the payment tender.

- **Match Types** - Used to define match types for the payment request. This section contains the following fields:

Field Name	Field Description	Mandatory (Yes or No)
Match Type	Used to indicate the match type using which you want to match the payment.	Yes
Show Default	Used to indicate whether the default payment amount should be displayed against the match type entities. <b>Note:</b> By default, the <b>Show Default</b> check box is selected when you select the match type.	No



Field Name	Field Description	Mandatory (Yes or No)
Entity	Indicates the match type entity. The valid values are: <ul style="list-style-type: none"> <li><b>Account</b> — Enables you to select the account whose unpaid bills, unpaid bill segments, settlement IDs, or contracts must be considered while matching the payment.</li> <li><b>Bill</b> — Enables you to select the unpaid bill against which you want to match the payment.</li> </ul>	Not applicable
Entity ID	Used to specify the account or bill ID depending on the match type entity.	Yes

**Note:** The **Edit** button appears only when the payment request is in the **Draft** status.

- Modify the details of the payment request, if required.

**Note:**

You can search for a payor account, auto pay route type, auto pay source, and entity by clicking the **Search**  icon corresponding to the respective field.

If you want to specify more than one match type within the payment request, click the **Add**  icon in the **Match Types** section and then specify the details. However, if you want to remove a match type from the payment request, click the **Delete**  icon corresponding to the match type.

You cannot edit an existing row in the **Match Types** section. If you want to edit the details of an existing row, you need to first remove the row and then add it again with the updated information.

- Define, edit, or remove characteristics from the payment request, if required.
- Click **Manual Distribution**.

The changes made to the payment request are saved. Depending on the information specified in the **Match Types** section, the entities are listed in the **Payment Distribution** zone. You can edit the payment amount against each entity, if required.

### **Related Topics**

For more information on...	See...
How to search for a payment request	<a href="#">Searching for a Payment Request</a> on page 1184
<b>Payment Request</b> screen	<a href="#">Payment Request (Used for Viewing)</a> on page 1186
<b>Payment Request</b> zone	<a href="#">Payment Request</a> on page 1186
<b>Payment Distribution</b> zone	<a href="#">Payment Distribution</a> on page 1192
How to define characteristics for a payment tender	<a href="#">Defining Characteristics for a Payment Tender</a> on page 1199

## Deleting a Payment Request

### **Procedure**

To delete a payment request:

1. Search for the payment request in the **Payment Request** screen.
2. In the **Search Results** section, click the link in the **Payment Request Information** column corresponding to the payment request that you want to delete.

The **Payment Request** screen appears.

3. Click the **Delete** button in the **Payment Request** zone.

A message appears confirming whether you want to delete the payment request.

**Note:** The **Delete** button appears only when the payment request is in the **Draft** status.

4. Click **OK**.

The payment request is deleted.

### **Related Topics**

<b>For more information on...</b>	<b>See...</b>
How to search for a payment request	<a href="#">Searching for a Payment Request</a> on page 1184
<b>Payment Request</b> screen	<a href="#">Payment Request (Used for Viewing)</a> on page 1186
<b>Payment Request</b> zone	<a href="#">Payment Request</a> on page 1186

## **Distributing the Tender or Payment Amount**

### **Procedure**

To distribute the tender or payment amount:

1. Search for the payment request in the **Payment Request** screen.
2. In the **Search Results** section, click the link in the **Payment Request Information** column corresponding to the payment request whose tender or payment amount you want to distribute.

The **Payment Request** screen appears.

3. Click the **Distribute** button in the **Payment Request** zone.

The Defer algorithm attached to the payment request type using which you have created the payment request is triggered. This algorithm checks whether the number of payment distribution records in the payment request exceeds the payment count defined in the Defer algorithm. If the number of payment distribution records in the payment request does not exceed the payment count, the system distributes the tender or payment amount in real time (i.e. immediately). However, if the number of payment distribution records in the payment request exceeds the payment count, the system distributes the tender or payment amount in the deferred mode.

**Note:**

Number of payment distribution records = (Number of bill segments present in each bill fetched using the Bill Weighted, Bill Regular, and Bill match type algorithm) + (Number of bill segments fetched using the Bill Segment match type algorithm) + (Number of contracts fetched using the Suspense Contract match type algorithm) + (Number of settlements fetched using the Settlement match type algorithm)

Deferred mode means in the background when the **Payment Request Periodic Monitor (C1-PAYRQ)** batch is invoked. You can configure the **Payment Request Periodic Monitor (C1-PAYRQ)** batch such that it is executed at regular intervals. When the **Payment Request Periodic Monitor (C1-PAYRQ)** batch is invoked, the system checks whether there are any payment requests in the **Deferred Distribution** status. If there is a payment request in the **Deferred Distribution** status, the system distributes the tender or payment amount.

On distributing the tender amount, the payment event, payments, payment segments, and payment tenders are created. The payments are created in the **Freezable** status. If any error occurs while creating the payment, the payment is created in the **Error** status. If all payments of a payment event are in the **Freezable** status, the status of the payment event is set to **Balanced**. However, if any payment of a payment event is in the **Error** status, the status of the payment event is set to **Unbalanced**. On distributing the payment amount (during transfer), the new payments are created in the **Freezable** status. If any error occurs while creating the new payment, the payment is created in the **Error** status. The status of the payment event is set to **Unbalanced**. The old payments in the payment event that you want to transfer remains in the **Frozen** or **Error** status.

Once the tender or payment amount is successfully distributed, the status of the payment request is changed to **Distributed**.

**Note:**

The **Distribute** button appears only when the payment request is in the **Draft** status.

The sum of payment amount should be equal to the tender or transfer (payment) amount. Otherwise, the system will not allow you to distribute the tender or payment amount.

### Related Topics

For more information on...	See...
How to search for a payment request	<a href="#">Searching for a Payment Request</a> on page 1184
<b>Payment Request</b> screen	<a href="#">Payment Request (Used for Viewing)</a> on page 1186
<b>Payment Request</b> zone	<a href="#">Payment Request</a> on page 1186
How to edit the payment amount against each entity	<a href="#">Editing the Payment Amount</a> on page 1200

## Distributing and Freezing the Tender or Payment Amount

### Procedure

To distribute and freeze the tender or payment amount:

1. Search for the payment request in the **Payment Request** screen.
2. In the **Search Results** section, click the link in the **Payment Request Information** column corresponding to the payment request whose tender or payment amount you want to distribute and freeze.

The **Payment Request** screen appears.

3. Click the **Distribute And Freeze** button in the **Payment Request** zone.

The Defer algorithm attached to the payment request type using which you have created the payment request is triggered. This algorithm checks whether the number of payment distribution records in the payment request exceeds the payment count defined in the Defer algorithm. If the number of payment distribution records in the payment request does not exceed the payment count, the system distributes and freezes the tender or payment amount in real time (i.e. immediately). However, if the number of payment distribution records in the payment request exceeds the payment count, the system distributes and freezes the tender or payment amount in the deferred mode.

**Note:**

Number of payment distribution records = (Number of bill segments present in each bill fetched using the Bill Weighted, Bill Regular, and Bill match type algorithm) + (Number of bill segments fetched using the Bill Segment match type algorithm) + (Number of contracts fetched using the Suspense Contract match type algorithm) + (Number of settlements fetched using the Settlement match type algorithm)

Deferred mode means in the background when the **Payment Request Periodic Monitor (C1-PAYRQ)** batch is invoked. You can configure the **Payment Request Periodic Monitor (C1-PAYRQ)** batch such that it is executed at regular intervals. When the **Payment Request Periodic Monitor (C1-PAYRQ)** batch is invoked, the system checks whether there are any payment requests in the **Deferred Distribution** status. If there is a payment request in the **Deferred Distribution** status, the system distributes the tender or payment amount.

On distributing and freezing the tender amount, the payment event, payments, payment segments, and payment tenders are created. The payments are created in the **Frozen** status. If any error occurs while creating the payment, the payment is created in the **Error** status. If all payments of a payment event are in the **Frozen** status, the status of the payment event is set to **Balanced**. However, if any payment of a payment event is in the **Error** status, the status of the payment event is set to **Unbalanced**. On distributing the payment amount (during transfer), the new payments are created in the **Frozen** status. If any error occurs while creating the new payment, the payment is created in the **Error** status. The status of the payment event is set to **Unbalanced**. The old payments in the payment event that you want to transfer remains in the **Frozen** or **Error** status.

Once the tender or payment amount is successfully distributed and frozen, the status of the payment request is changed to **Processed**.

**Note:**

The **Distribute And Freeze** button appears only when the payment request is in the **Draft** status.

The sum of payment amount should be equal to the tender or transfer (payment) amount. Otherwise, the system will not allow you to distribute the tender or payment amount.

**Related Topics**

For more information on...	See...
How to search for a payment request	<a href="#">Searching for a Payment Request</a> on page 1184
<b>Payment Request</b> screen	<a href="#">Payment Request (Used for Viewing)</a> on page 1186
<b>Payment Request</b> zone	<a href="#">Payment Request</a> on page 1186
How to edit the payment amount against each entity	<a href="#">Editing the Payment Amount</a> on page 1200

**Redistributing the Tender or Payment Amount****Procedure**

To redistribute the tender or payment amount:

1. Search for the payment request in the **Payment Request** screen.
2. In the **Search Results** section, click the link in the **Payment Request Information** column corresponding to the payment request whose tender or payment amount you want to redistribute.

The **Payment Request** screen appears.

3. In the **Payment Distribution** zone, click the **Redistribute** button in the **Redistribute** column corresponding to the payment distribution whose tender or payment amount you want to redistribute.



The required payment gets redistributed among the account's contracts.

**Note:** The **Redistribute** button appears only when the payment status is in **Incomplete, Error, or Freezable** status.

### Related Topics

For more information on...	See...
How to search for a payment request	<a href="#">Searching for a Payment Request</a> on page 1184
<b>Payment Request</b> screen	<a href="#">Payment Request (Used for Viewing)</a> on page 1186
<b>Payment Request</b> zone	<a href="#">Payment Request</a> on page 1186
How to edit the payment amount against each entity	<a href="#">Editing the Payment Amount</a> on page 1200

## Editing the Payment Segment Amount

Before you freeze the payments, the system allows you to edit the pay segment amount of the payments which are in the **Freezable** status. You can edit the amount only when there are multiple pay segments in a payment.

### Procedure

To edit the payment segment amount:

1. Search for the payment request in the **Payment Request** screen.
2. In the **Search Results** section, click the link in the **Payment Request Information** column corresponding to the payment request whose details you want to edit.

The **Payment Request** screen appears.

3. Click the **Detail** button in the **Payment Distribution** zone.

The **Edit Payment Segment Amount** screen appears. It contains the following fields:

Field Name	Field Description
Payment Event Information	Displays information about the payment event which is created through the payment request.
Payment Information	Displays information about the payment which is created through the payment event.
Payee Account Information	Displays information about the account for which the payment is made.
Match Value	Displays information about the entity against which the payment is matched.
Payment Amount	Displays the total payment amount.
Running Total	Displays the sum of payment amount specified against each pay segment.
Running Balance	Displays the difference between total payment amount and running total. The running balance is highlighted in the red color when the difference amount is non-zero.

In addition, this section contains the following columns:





Column Name	Column Description	Mandatory (Yes or No)
Sr No	Indicates the sequence number of the pay segment.	Not applicable

Column Name	Column Description	Mandatory (Yes or No)
Entity Information	Displays information about the entity (such as bill segment or contract) against which the pay segment is created.	Not applicable
Total Amount	Displays the entity amount. If the pay segment is created against a contract, the system considers all bill segments of the bill which are created against the contract and calculates the total bill segment amount.	Not applicable
Unpaid Amount	Displays the amount which is eligible for payment. If the pay segment is created against a contract, the system considers all bill segments of the bill which are created against the contract and calculates the total unpaid bill segment amount.	Not applicable
Payment Amount	Used to specify the payment amount that you want to distribute against the pay segment.  <div style="border: 1px solid black; padding: 5px;"> <p><b>Note:</b> This field is non-editable when:</p> <ul style="list-style-type: none"> <li>• There is only one pay segment in a payment.</li> <li>• A user with the approval To Do role is reviewing the pay segment amount.</li> </ul> </div>	Yes
Payment Currency	Indicates the currency in which the payment was made.	Not applicable
Pay Segment ID	Displays the pay segment ID.	Not applicable

**Note:**

The **Detail** button appears in the **Detail** column only when:

- The payment request is in the **Distributed** or **Approval In Progress** status
- The payment is in the **Freezable** status.

Pagination is used to display limited number of records in the **Edit Payment Segment Amount** screen. You can change the number of records displayed per page, if required. You can use the navigation buttons, such as **First** () , **Previous** () , **Next** () , and **Last** () to navigate between pages. You can also select the page to which you want to navigate from the **Go To** list.

4. Modify the payment amount against a pay segment, if required.

**Note:** The sum of payment segment amount should be equal to the payment amount.

5. Click **Redistribute**.

The payment amount is redistributed among the pay segments.

**Note:** The **Redistribute** button is disabled when the **Payment Amount** field is non-editable.

6. Click **Close**.

### Related Topics

For more information on...	See...
How to search for a payment request	<a href="#">Searching for a Payment Request</a> on page 1184
<b>Payment Request</b> screen	<a href="#">Payment Request (Used for Viewing)</a> on page 1186
<b>Payment Distribution</b> zone	<a href="#">Payment Distribution</a> on page 1192

## Freezing Payments Created Through a Payment Request

### Procedure

To freeze the payments created through a payment request:

1. Search for the payment request in the **Payment Request** screen.
2. In the **Search Results** section, click the link in the **Payment Request Information** column corresponding to the payment request whose payments you want to freeze.

The **Payment Request** screen appears.

3. If required, you can edit the amount of a payment segment before freezing the payments.
4. Click the **Freeze** button in the **Payment Request** zone.

The system behaves in the following manner:

If you are...	Then
Freezing the payments created through a payment creation request	The status of the payments which are in the <b>Freezable</b> status is changed to <b>Frozen</b> . In addition, the status of the payment request is changed to <b>Processed</b> .
Freezing the payments created through a payment transfer request	The status of the old payments which are in the <b>Frozen</b> status is changed to <b>Cancelled</b> . The old payments which are in the <b>Error</b> status are deleted. The status of the new payments which are in the <b>Freezable</b> status is changed to <b>Frozen</b> . The status of the payment event is changed to <b>Balanced</b> when there are no new payments in the <b>Error</b> status. In addition, the status of the payment request is changed to <b>Processed</b> .

### Note:

The **Freeze** button appears only when:

- The payment request is in the **Distributed** status.
- The **Approval Required** check box is not selected in the payment request type using which the payment request is created.

For each payment, ensure that the sum of payment segment amount is equal to the payment amount. Otherwise, the system will not allow you to freeze the payments created through the payment request.

### Related Topics

For more information on...	See...
How to search for a payment request	<a href="#">Searching for a Payment Request</a> on page 1184
<b>Payment Request</b> screen	<a href="#">Payment Request (Used for Viewing)</a> on page 1186

For more information on...	See...
Payment Request zone	<a href="#">Payment Request</a> on page 1186
How to edit the amount of a payment segment	<a href="#">Editing the Payment Segment Amount</a> on page 1209

## Submitting a Payment Request for Approval

### Procedure

To submit a payment request for approval:

1. Search for the payment request in the **Payment Request** screen.
2. In the **Search Results** section, click the link in the **Payment Request Information** column corresponding to the payment request that you want to submit for approval.

The **Payment Request** screen appears.

3. If required, you can edit the amount of a payment segment before submitting the payment request for approval.
4. Click the **Submit for Approval** button in the **Payment Request** zone.

The status of the payment request is changed to **Approval In Progress**. A To Do is created using the **C1-PAYRQ** To Do type. Users having a To Do role to which the **C1-PAYRQ** To Do type is associated can view the To Do from the **To Do List** screen.

### **Note:**

The **Submit for Approval** button appears only when:

- The payment request is in the **Distributed** status.
- The **Approval Required** check box is selected in the payment request type using which the payment request is created.

For each payment, ensure that the sum of payment segment amount is equal to the payment amount. Otherwise, the system will not allow you to submit the payment request for approval.

### Related Topics

For more information on...	See...
How to search for a payment request	<a href="#">Searching for a Payment Request</a> on page 1184
Payment Request screen	<a href="#">Payment Request (Used for Viewing)</a> on page 1186
Payment Request zone	<a href="#">Payment Request</a> on page 1186
How to edit the amount of a payment segment	<a href="#">Editing the Payment Segment Amount</a> on page 1209

## Approving a Payment Request

You can view the number of payment requests which are pending for approval in the **Payment Request** screen. The approver can review, and accordingly approve or reject the payment request based on the observations.

**Note:** The system will not allow you to approve or reject a payment request submitted by you.

### Procedure

To approve a payment request:

1. Do either of the following:

If you want to	Then
Approve a payment request through the <b>Payment Request</b> screen	<ol style="list-style-type: none"> <li>1. Search for the payment request in the <b>Payment Request</b> screen.</li> <li>2. In the <b>Search Results</b> section, click the link in the <b>Payment Request Information</b> column corresponding to the payment request which you want to review.</li> </ol>
Approve a payment request from the <b>To Do List</b> screen	<ol style="list-style-type: none"> <li>1. Click the <b>Menu</b> link in the <b>Application</b> toolbar. A list appears.</li> <li>2. From the <b>Main</b> menu, select <b>To Do</b> and then click <b>To Do List</b>. The <b>To Do Type for User Search</b> window appears.</li> <li>3. Enter <b>C1-PAYRQ</b> in the <b>To Do Type</b> field.</li> <li>4. Click the <b>Search</b> button corresponding to the <b>To Do Type</b> field. The <b>To Do List</b> screen appears.</li> <li>5. Select the <b>Open</b> option from the <b>Filter by</b> list to view all unassigned To Dos.</li> <li>6. Click the link in the <b>Message</b> column corresponding to the To Do of the payment request that you want to review.</li> </ol>

The **Payment Request** screen appears.

2. Review the payment request details.
3. Click the **Approve** button in the **Payment Request** zone.

The system behaves in the following manner:

If you are...	Then
Approving a payment creation request	The status of the payments which are in the <b>Freezable</b> status is changed to <b>Frozen</b> . In addition, the status of the payment request is changed to <b>Processed</b> .
Approving a payment transfer request	The status of the old payments which are in the <b>Frozen</b> status is changed to <b>Cancelled</b> . The old payments which are in the <b>Error</b> status are deleted. The status of the new payments which are in the <b>Freezable</b> status is changed to <b>Frozen</b> . The status of the payment event is changed to <b>Balanced</b> when there are no new payments in the <b>Error</b> status. In addition, the status of the payment request is changed to <b>Processed</b> .

**Note:** The **Approve** button appears only when:

- The payment request is in the **Approval In Progress** status.
- A user with the approval To Do role is reviewing the payment request.

### **Related Topics**

<b>For more information on...</b>	<b>See...</b>
How to search for a payment request	<a href="#">Searching for a Payment Request</a> on page 1184
<b>Payment Request</b> screen	<a href="#">Payment Request (Used for Viewing)</a> on page 1186
<b>Payment Request</b> zone	<a href="#">Payment Request</a> on page 1186

## **Rejecting a Payment Request**

### **Prerequisites**

To reject a payment request, you should have:

- Rejection reasons defined in the application

### **Note:**

While rejecting a payment request, you need to specify the reason why you want to reject the payment request. If you are rejecting a payment creation request, you can select the appropriate rejection reason only when you have defined the reasons for the **Rejected** status of the **C1-PaymentRequest** business object in the **Status Reason** screen. However, if you are rejecting a payment transfer request, you can select the appropriate rejection reason only when you have defined the reasons for the **Rejected** status of the **C1-PaymentTransferRequest** business object in the **Status Reason** screen.

The system will not allow you to approve or reject a payment request submitted by you.

### **Procedure**

To reject a payment request:

1. Do either of the following:

<b>If you want to...</b>	<b>Then...</b>
Reject a payment request through the <b>Payment Request</b> screen	<ol style="list-style-type: none"> <li>1. Search for the payment request in the <b>Payment Request</b> screen.</li> <li>2. In the <b>Search Results</b> section, click the link in the <b>Payment Request Information</b> column corresponding to the payment request which you want to review.</li> </ol>
Reject a payment request from the <b>To Do List</b> screen	<ol style="list-style-type: none"> <li>1. Click the <b>Menu</b> link in the <b>Application</b> toolbar. A list appears.</li> <li>2. From the <b>Main</b> menu, select <b>To Do</b> and then click <b>To Do List</b>.</li> </ol>

If you want to...	Then...
	<p>The <b>To Do Type for User Search</b> window appears.</p> <ol style="list-style-type: none"> <li>Enter <b>C1-PAYRQ</b> in the <b>To Do Type</b> field.</li> <li>Click the <b>Search</b> button corresponding to the <b>To Do Type</b> field.</li> </ol> <p>The <b>To Do List</b> screen appears.</p> <ol style="list-style-type: none"> <li>Select the <b>Open</b> option from the <b>Filter by</b> list to view all unassigned To Dos.</li> <li>Click the link in the <b>Message</b> column corresponding to the To Do of the payment request that you want to review.</li> </ol>

The **Payment Request** screen appears.

- Review the payment request details.
- If required, you can review the payment segment amount of each payment by clicking the **Detail** button in the **Detail** column corresponding to the payment in the **Payment Distribution** zone.
- Click the **Reject** button in the **Payment Request** zone.

The **Status Reason** window appears. It contains following fields:

Field Name	Field Description	Mandatory (Yes or No)
Status Reason	Used to indicate the reason why you want to reject the payment request.	Yes

**Note:** The **Reject** button appears only when:

- The payment request is in the **Approval In Progress** status.
- A user with the approval To Do role is reviewing the payment request.

- Select the rejection reason from the **Status Reason** list.
- Click **Save**.

If the approver rejects a payment creation request, the payment event, payments, payment segments, and payment tender which are created through the payment creation request are deleted. However, if the approver rejects a payment transfer request, the new payments which are created through the payment transfer request are deleted. In addition, the status of the payment creation or transfer request is changed to **Rejected**.

### **Related Topics**

For more information on...	See...
How to search for a payment request	<a href="#">Searching for a Payment Request</a> on page 1184
<b>Payment Request</b> screen	<a href="#">Payment Request (Used for Viewing)</a> on page 1186
<b>Payment Request</b> zone	<a href="#">Payment Request</a> on page 1186

## Discarding a Payment Request

1. Search for the payment request in the **Payment Request** screen.
2. In the **Search Results** section, click the link in the **Payment Request Information** column corresponding to the payment request which you want to discard.
3. Click the **Discard** button in the **Payment Request** zone.

### Note:

The **Discard** button appears only when the payment request is in **Distributed** status.

If the approver discards a payment creation request, the payment event, payments, payment segments, and payment tender which are created through the payment creation request are deleted. However, if the approver discards a payment transfer request, the new payments which are created through the payment transfer request are deleted. In addition, the status of the payment creation or transfer request is changed to **Discarded**.

Discarding a payment request is similar to rejecting a payment request. However, you can only reject a payment request, when approval workflow is on while creating a payment request but discarding a payment request can be done in both the cases, when the approval workflow is on or off.

### Related Topics

For more information on...	See...
How to search for a payment request	<a href="#">Searching for a Payment Request</a> on page 1184
<b>Payment Request</b> screen	<a href="#">Payment Request (Used for Viewing)</a> on page 1186
<b>Payment Request</b> zone	<a href="#">Payment Request</a> on page 1186

## Viewing the Log of a Payment Request

### Procedure

To view the log of a payment request:

1. Search for the payment request in the **Payment Request** screen.
2. In the **Search Results** section, click the link in the **Payment Request Information** column corresponding to the payment request whose log you want to view.

The **Payment Request** screen appears. It consists of the following tabs:

- **Main** – This tab contains the following two zones:
    - **Payment Request** – Displays the details of the payment request.
    - **Payment Distribution** – Lists the payment distribution records of the payment request.
  - **Log** – This tab lists the complete trail of actions performed on the payment request.
3. Click the **Log** tab.

The **Payment Request Log** zone in the **Log** tab contains the following columns:



Column Name	Column Description
Date/Time	Displays the date and time when the action was performed on the payment request.
Details	Displays the details about the action performed on the payment request.
User	Indicates the user who has performed the action on the payment request.
Log Type	Indicates the type of log.
Related Object	Indicates the object or entity which is generated when the action is performed on the payment request.
Status Reason	Indicates the reason why the payment request was rejected.

**Note:** You can manually add a log entry for the payment request by clicking the **Add Log Entry** link in the upper right corner of the **Payment Request Log** zone.

### Related Topics

For more information on...	See...
How to search for a payment request	<a href="#">Searching for a Payment Request</a> on page 1184
How to add a log entry for a payment request	<a href="#">Adding a Log Entry for a Payment Request</a> on page 1217

## Adding a Log Entry for a Payment Request

### Procedure

To add a log entry for a payment request:

1. Search for the payment request in the **Payment Request** screen.
2. In the **Search Results** section, click the link in the **Payment Request Information** column corresponding to the payment request whose log you want to edit.

The **Payment Request** screen appears. It consists of the following tabs:

- **Main** – This tab contains the following two zones:
  - **Payment Request** – Displays the details of the payment request.
  - **Payment Distribution** – Lists the payment distribution records of the payment request.
- **Log** – This tab lists the complete trail of actions performed on the payment request.

3. Click the **Log** tab.

The **Log** tab appears.

4. Click the **Add Log Entry** link in the upper right corner of the **Payment Request Log** zone.

The **Add Payment Request Log** window appears. It contains the following fields:

Field Name	Field Description	Mandatory (Yes or No)
Payment Request Information	Displays information about the payment request.	Not applicable

Field Name	Field Description	Mandatory (Yes or No)
Log Details	Used to specify additional comments on the payment request.	Yes

5. Enter the comments in the **Log Details** field.

6. Click **Save**.

The log entry is added in the **Payment Request Log** zone.

### **Related Topics**

For more information on...	See...
How to search for a payment request	<a href="#">Searching for a Payment Request</a> on page 1184

## **Payment Event Summary**

---

The **Payment Event Summary** screen allows you to search for a payment event using various search criteria. Through this screen, you can:

- View the payments created through a payment event
- View payment segments of a payment
- Transfer one or more payments of a payment event to another payee account
- Cancel a payment event
- Delete a payment event
- Cancel a payment of a payment event
- Delete a payment of a payment event
- Refund a payment which is matched against the suspense or excess credit contract



This screen consists of following zones:

- [Search Payment Event](#) on page 1218
- [Payments](#) on page 1221
- [Payment Segments](#) on page 1223

### **Search Payment Event**

The **Search Payment Event** zone allows you to search for a payment event using various search criteria. This zone contains the following two sections:

- **Search Criteria** — The **Search Criteria** section contains the following fields:

Field Name	Field Description	Mandatory (Yes or No)
Search By	<p>Used to indicate whether you want to search for a payment event using the payor, payment event, tender, or contract details. The valid values are:</p> <ul style="list-style-type: none"> <li>• Payor Account/Payment Event</li> <li>• Tender Details</li> <li>• Suspense/Excess Credit Contract</li> </ul> <p><b>Note:</b> By default, the <b>Payor Account/Payment Event</b> option is selected.</p>	Yes
Payment Event ID	<p>Used to search a particular payment event.</p> <p><b>Note:</b> This field appears only when you select the <b>Payor Account/Payment Event</b> option from the <b>Search By</b> list. The <b>Search</b>  icon appears corresponding to this field. On clicking the <b>Search</b> icon, the <b>Payment Event Search</b> window appears.</p>	No
Payor Account ID	<p>Used to search payment events which are created for a particular payor account.</p> <p><b>Note:</b> This field appears only when you select the <b>Payor Account/Payment Event</b> option from the <b>Search By</b> list. The <b>Search</b>  icon appears corresponding to this field. On clicking the <b>Search</b> icon, the <b>Account Search</b> window appears.</p>	No
Payor Name	<p>Used to search payment events which are created for a particular payor.</p> <p><b>Note:</b> This field appears only when you select the <b>Payor Account/Payment Event</b> option from the <b>Search By</b> list.</p>	No
Payment Date	<p>Used to search payment events which are created on a particular date.</p> <p><b>Note:</b> This field appears only when you select the <b>Payor Account/Payment Event</b> option from the <b>Search By</b> list.</p>	No
Tender Type	<p>Used to search payment events where a particular tender type is used.</p> <p><b>Note:</b> This field appears only when you select the <b>Tender Details</b> option from the <b>Search By</b> list.</p>	No

Field Name	Field Description	Mandatory (Yes or No)
Check Number	Used to search a payment event which includes payments made through a particular check.  <b>Note:</b> This field appears only when you select the <b>Tender Details</b> option from the <b>Search By</b> list.	No
MICR ID	Used to search payment events which include payments made with a particular MICR code.  <b>Note:</b> This field appears only when you select the <b>Tender Details</b> option from the <b>Search By</b> list.	No
Contract ID	Used to search payment events which include payments made against a particular suspense or excess credit contract.  <b>Note:</b> This field appears only when you select the <b>Suspense/ Excess Credit Contract</b> option from the <b>Search By</b> list.  The <b>Search</b>  icon appears corresponding to this field. On clicking the <b>Search</b> icon, the <b>Contract Search</b> window appears.	No

**Note:** You must specify at least one search criterion while searching for a payment event.

- **Search Results** — On clicking the **Search** button, the search results appear based on the specified search criteria. The **Search Results** section contains the following columns:

Column Name	Column Description
Payment Event Information	Displays additional information about the payment event.  <b>Note:</b> It has a link. On clicking the link, the <b>Payment Event</b> screen appears where you can view the details of the respective payment event.
Transfer	On clicking the <b>Transfer</b> button, you can transfer all payments (which are in either <b>Frozen</b> and <b>Error</b> status) of the payment event to another payee account.  <b>Note:</b> The <b>Transfer</b> button appears only when: <ul style="list-style-type: none"> <li>• One or more payments of the payment event are in the <b>Frozen</b> or <b>Error</b> status.</li> <li>• There is no payment transfer request which is currently in progress for the payment event.</li> </ul>

Column Name	Column Description
Cancel	<p>On clicking the <b>Cancel</b> button, you can cancel all payments (which are in the <b>Frozen</b> status) of the payment event.</p> <p><b>Note:</b> The <b>Cancel</b> button appears only when:</p> <ul style="list-style-type: none"> <li>• One or more payments of the payment event are in the <b>Frozen</b> status.</li> <li>• One or more payments of the payment event are not in the <b>Freezable</b> or <b>Error</b> status.</li> <li>• There is no payment transfer request which is currently in progress for the payment event.</li> </ul>
Delete	<p>On clicking the <b>Delete</b> button, you can delete the payment event.</p> <p><b>Note:</b> The <b>Delete</b> button appears only when the payments of a payment event are in the <b>Freezable</b>, <b>Error</b> or <b>Incomplete</b> status.</p>
Additional Information	Displays information about the status of the payment event.
Payment Date	Displays the date when the payment was made.
Payor Name	<p>Indicates the person who has made the payment.</p> <p><b>Note:</b> It has a link. On clicking the link, the <b>Person</b> screen appears where you can view the details of the respective person.</p>
Payor Account ID	<p>Indicates the account which made the payment.</p> <p><b>Note:</b> It has a link. On clicking the link, the <b>Account</b> screen appears where you can view the details of the respective account.</p>
Tender Amount	Displays the tender amount.
Payment Event ID	Displays the payment event ID.

### Related Topics

For more information on...	See...
How to search for a payment event	<a href="#">Searching for a Payment Event</a> on page 1223
How to transfer payments of a payment event	<a href="#">Creating a Payment Transfer Request</a> on page 1224
How to cancel a payment event	<a href="#">Cancelling a Payment Event</a> on page 1228
How to delete a payment event	<a href="#">Deleting a Payment Event</a> on page 1229

## Payments

The **Payments** zone lists all payments created through the payment event. This zone contains the following columns:

Column Name	Column Description
Payment ID	<p>Displays the payment ID.</p> <p><b>Note:</b> It has a link. On clicking the link, the <b>Payment</b> screen appears with the details of the respective payment.</p>

Column Name	Column Description
Payee Account Information	<p>Displays information about the account for which the payment was made. In addition, this column has a context menu which helps in navigating to other screens in the application.</p> <p><b>Note:</b> It has a link. On clicking the link, the <b>Account</b> screen appears with the details of the respective account.</p>
Payment Amount	Displays the amount paid through the tender.
Payment Currency	Indicates the currency in which the payment was made.
Payment Status	<p>Indicates the status of the payment. The valid values are:</p> <ul style="list-style-type: none"> <li>• Incomplete</li> <li>• Error</li> <li>• Freezable</li> <li>• Frozen</li> <li>• Canceled</li> </ul>
Match Type	Indicates the match type using which the payment was matched.
Match Value	Indicates the entity (such as bill, bill segment, or contract) against which the payment was matched.
Error Message	Indicates the reason why the payment is in the <b>Error</b> status.
Payor Account ID	Indicates the account which made the payment.
Refund Amount	Displays the amount which is already refunded to the payor account.

In addition, this zone contains the following buttons:

Button Name	Button Description
Transfer	<p>Used to transfer the payment to another payee account.</p> <p><b>Note:</b> You can transfer a payment only when it is in the <b>Frozen</b> or <b>Error</b> status.</p>
Cancel	<p>Used to cancel the payment.</p> <p><b>Note:</b> You can cancel a payment only when it is in the <b>Frozen</b> status.</p>
Delete	<p>Used to delete the payment.</p> <p><b>Note:</b> You can delete a payment only when it is in the <b>Freezable</b> or <b>Error</b> status.</p>
Refund	<p>Used to refund the payment amount to the payor account.</p> <p><b>Note:</b> You can refund the payment amount to the payor account only when:</p> <ul style="list-style-type: none"> <li>• The payment is matched against the suspense or excess credit contract.</li> <li>• The payment is in the <b>Frozen</b> status.</li> </ul>

### Related Topics

For more information on...	See...
How to view payments created through a payment event	<a href="#">Viewing Payments Created Through a Payment Event</a> on page 1230
How to cancel a payment	<a href="#">Cancelling a Payment</a> on page 1230
How to delete a payment	<a href="#">Deleting a Payment</a> on page 1231
How to transfer a payment	<a href="#">Creating a Payment Transfer Request</a> on page 1224
How to refund a payment	<a href="#">Creating a Refund Request</a> on page 1428

## Payment Segments

The **Payment Segments** zone lists payment segments of a payment. This zone contains the following columns:

Column Name	Column Description
Pay Segment ID	Displays the payment segment ID. <b>Note:</b> It has a link. On clicking the link, the <b>Pay Segments</b> tab of the <b>Payment</b> screen appears where you view the details of the payment segment.
Contract Information	Displays information about the contract against which the payment segment is created. In addition, this column has a context menu which helps in navigating to other screens in the application. <b>Note:</b> It has a link. On clicking the link, the <b>Contract</b> screen appears where you can view the details of the respective contract.
Payment Amount	Displays the payment segment amount.
Match Event ID	Indicates the match event which is created for the payment segment. <b>Note:</b> It has a link. On clicking the link, the <b>Match Event</b> screen appears where you can view the details of the respective match event.

### Related Topics

For more information on...	See...
How to view payment segments of a payment	<a href="#">Viewing Payment Segments of a Payment</a> on page 1231

## Searching for a Payment Event

### Prerequisites

To search for a payment event, you should have:

- Tender types defined in the application

### Procedure

To search for a payment event:

1. Click the **Menu** link in the **Actions/Navigation** area.  
A list appears.
2. Select the **Main Menu** option from the list.

- From the **Main Menu**, select **Financial** and then click **Payment Event Summary**.

The **Payment Event Summary** screen appears.

- Enter the search criteria in the **Search Payment Event** zone.

**Note:**

You can search for a payment event and payor account by clicking the **Search**  icon corresponding to the respective field.

ORMB search engine supports wildcard search, where you can substitute the percentage (%) symbol as a stand in for any word or letter in a search criteria. You can use the ‘%’ wildcard character in all input fields except the date and ID fields. The ‘%’ wildcard character is suffixed automatically at the end of the partial search criteria. Therefore, you may or may not specify the wildcard character at the end of the partial search criteria. However, you have to prefix the wildcard character manually wherever required.

- Click **Search**.

A list of payment events that meet the search criteria appears in the **Search Results** section.

### Related Topics

For more information on...	See...
<b>Payment Event Summary</b> screen	<a href="#">Payment Event Summary</a> on page 1218
<b>Search Payment Event</b> zone	<a href="#">Search Payment Event</a> on page 1218

## Creating a Payment Transfer Request

The system allows you to transfer payments through a payment request. You can transfer all payments or individual payment of a payment event. You can only transfer payments which are in the **Frozen** or **Error** status.

### Prerequisites

To create a payment transfer request, you should have:

- Payment request types defined in the application (where the **Transfer** check box is selected)
- Payment cancel reasons defined in the application (where the **Payment Transfer** check box is selected)

### Procedure

To create a payment transfer request:

- Search for the payment event (whose payments you want to transfer) in the **Payment Event Summary** screen.
- Do either of the following:

If you want to...	Then...
Transfer all payments of a payment event	<ol style="list-style-type: none"> <li>In the <b>Search Results</b> section, click the <b>Transfer</b> button in the <b>Transfer</b> column corresponding to the payment event whose payments you want to transfer.</li> </ol>



If you want to...	Then...
	<p><b>Note:</b> The <b>Transfer</b> button appears only when:</p> <ul style="list-style-type: none"> <li>• One or more payments of the payment event are in the <b>Frozen</b> or <b>Error</b> status.</li> <li>• There is no payment transfer request which is currently in progress for the payment event.</li> </ul>
Transfer one or more payments of a payment event	<ol style="list-style-type: none"> <li>1. In the <b>Search Results</b> section, click the <b>Broadcast</b>  icon corresponding to the payment event whose payments you want to view.  The <b>Payments</b> zone appears.</li> <li>2. Select the check box corresponding to the payments that you want to transfer.</li> <li>3. Click the <b>Transfer</b> button in the <b>Payments</b> zone.</li> </ol> <p><b>Note:</b> You can transfer a payment only when it is in the <b>Frozen</b> or <b>Error</b> status.</p>

The **Select Payment Request Type** screen appears. It contains the following fields:

Field Name	Field Description	Mandatory (Yes or No)
Payment Request Type	Used to indicate the payment request type using which you want to create the payment request.  <b>Note:</b> The list includes only those payment request types where the <b>Transfer</b> check box is selected.	Yes

3. Select the required payment request type from the respective field.

4. Click **OK**.

- **Main** - Used to specify basic details about the payment request. This section contains the following fields:

Field Name	Field Description	Mandatory (Yes or No)
Payment Request Type	Indicates the payment request type using which you want to create the payment request.	Not applicable
Payment Event Information	Displays information about the payment event whose payments you want to transfer.	Not applicable
Transfer Amount	Displays the total payment amount which you want to transfer.	Not applicable

Field Name	Field Description	Mandatory (Yes or No)
Payment Date	Used to specify the date when the payment was transferred.  <b>Note:</b> By default, the current date appears in this field.	Yes
Transfer Reason	Used to indicate the reason why you want to transfer the payments.  <b>Note:</b> The list includes only those payment cancel reasons where the <b>Payment Transfer</b> check box is selected.	Yes

- **Payor Account Details** — This section contains the following columns:

Column Name	Column Description
Payor Account Information	Displays information about the payor's account whose payments you want to transfer.

- **Payment Details** — This section contains the following columns:

Column Name	Column Description
Payment(s)	Displays information about the payment that you want to transfer.

- **Match Types** - Used to define match types for the payment request. This section contains the following fields:

Field Name	Field Description	Mandatory (Yes or No)
Match Type	Used to indicate the match type using which you want to match the payment.	Yes
Show Default	Used to indicate whether the default payment amount should be displayed against the match type entities.  <b>Note:</b> By default, the <b>Show Default</b> check box is selected when you select the match type.	No
Entity	Indicates the match type entity. The valid values are: <ul style="list-style-type: none"> <li>• <b>Account</b> — Enables you to select the account whose unpaid bills, unpaid bill segments, settlement IDs, or contracts must be considered while matching the payment.</li> <li>• <b>Bill</b> — Enables you to select the unpaid bill against which you want to match the payment.</li> </ul>	Not applicable
Entity ID	Used to specify the account or bill ID depending on the match type entity.	Yes

5. Enter the required details.

**Note:**

You can search for an entity (such as account or bill) by clicking the **Search** (🔍) icon corresponding to the respective field.

If you want to specify more than one match type within the payment request, click the **Add** (+) icon in the **Match Types** section and then specify the details. However, if you want to remove a match type from the payment request, click the **Delete** (🗑️) icon corresponding to the match type.

**6. Click Manual Distribution.**

The payment request is created and the status of the payment request is set to **Draft**. The **Payment Request** screen appears. Depending on the match type and match entity specified while creating the payment request, the following entities are listed in the **Payment Distribution** zone:

Match Type	Match Entity	Entities
By Bill Regular	Account	Unpaid bills of the account
By Bill Weighted	Account	Unpaid bills of the account
By Bill	Bill	Unpaid bill
By Bill Segments	Account	Unpaid bill segments
By Suspense Contract	Account	Contracts of the account <div style="border: 1px solid black; padding: 5px; margin-top: 10px;"> <p><b>Note:</b> Only contracts of the contract type where the <b>Eligible for Billing</b> flag is set to <b>No</b> and <b>Special Role</b> flag is set to <b>Suspense</b> are listed in the <b>Payment Distribution</b> zone. If no contracts with this specification exist for the account, the system checks whether there is any such contract type (where the <b>Eligible for Billing</b> flag is set to <b>No</b> and <b>Special Role</b> flag is set to <b>Suspense</b>) defined for the division to which the account belongs. If there is any such contract type defined for the division, the system creates the contract for the account using the respective contract type and the same is listed in <b>Payment Distribution</b> zone.</p> </div>
By Settlement	Account	Unpaid bill segments where the settlement account is stamped

If the **Show Default** check box is not selected against a match type while creating the payment request, the payment amount against the respective match type entities is set to zero. However, if the **Show Default** check box is selected against a match type, the payment amount appears against the respective match type entities. The transfer amount is divided among the entities in the sequence of match types (where **Show Default** check box is selected) followed by the sequence of bill, bill segment, or contract start date. You can then edit the payment amount, if required.

**Note:**

If a payment request is already created for a payee account and is currently in progress, the system will not allow you to create another payment request for the payee account until the previous payment request is in the **Processed** or **Rejected** status.

The system does not allow you to create a payment request for a payee account when the respective match type entities (such as unpaid bills, unpaid bill segments, contracts, or settlement IDs do not exists for the payee account.

**Related Topics**

<b>For more information on...</b>	<b>See...</b>
How to search for a payment event	<a href="#">Searching for a Payment Event</a> on page 1223
<b>Payment Request</b> screen	<a href="#">Payment Request (Used for Viewing)</a> on page 1186
<b>Payment Distribution</b> zone	<a href="#">Payment Distribution</a> on page 1192
How to view the details of a payment transfer request	<a href="#">Viewing the Payment Request Details</a> on page 1185
How to edit a payment transfer request	<a href="#">Editing a Payment Request</a> on page 1202
How to delete a payment transfer request	<a href="#">Deleting a Payment Request</a> on page 1205
How to edit the payment amount against each entity	<a href="#">Editing the Payment Amount</a> on page 1200
How to distribute the tender or payment amount	<a href="#">Distributing the Tender or Payment Amount</a> on page 1206
How to freeze the payments created through a payment transfer request	<a href="#">Freezing Payments Created Through a Payment Request</a> on page 1211
How to approve a payment transfer request	<a href="#">Approving a Payment Request</a> on page 1212
How to reject a payment transfer request	<a href="#">Rejecting a Payment Request</a> on page 1214
How to edit the amount of a payment segment	<a href="#">Editing the Payment Segment Amount</a> on page 1209
How to submit a payment transfer request for approval	<a href="#">Submitting a Payment Request for Approval</a> on page 1212

**Canceling a Payment Event****Prerequisites**

To cancel a payment event, you should have:

- Payment cancel reasons defined in the application

**Procedure**

To cancel a payment event:

1. Search for the payment event in the **Payment Event Summary** screen.
2. In the **Search Results** section, click the **Cancel** button in the **Cancel** column corresponding to the payment event that you want to cancel.

The **Cancel** window appears. It contains the following fields:

<b>Field Name</b>	<b>Field Description</b>	<b>Mandatory (Yes or No)</b>
Cancel Reason	Used to indicate the reason why you want to cancel the payment event.	Yes

Field Name	Field Description	Mandatory (Yes or No)
Bank	Used to indicate the bank which should be charged for the cancellation.	Yes
Bank Account	Used to indicate the bank account which should be charged for the cancellation.	Yes

**Note:** The **Cancel** button appears only when:

- One or more payments of the payment event are in the **Frozen** status.
- One or more payments of the payment event are not in the **Freezable** or **Error** status.
- There is no payment transfer request which is currently in progress for the payment event.

3. Select the cancel reason, bank, and bank account from the respective fields.
4. Click **OK**.

The payment tender and all payments in the payment event are cancelled.

#### Related Topics

For more information on...	See...
How to search for a payment event	<a href="#">Searching for a Payment Event</a> on page 1223

## Deleting a Payment Event

You can delete a payment event only when the payment(s) of the payment event are in the **Freezable**, **Error**, or **Incomplete** status. On deleting a payment event, the payment event, payments, payment segments, and payment tender are deleted.

#### Procedure

To delete a payment event:

1. Search for the payment event in the **Payment Event Summary** screen.
2. In the **Search Results** section, click the **Delete** button in the **Delete** column corresponding to the payment event that you want to delete.

A message appears confirming whether you want to delete the payment event.

**Note:** The **Delete** button appears only when the payments of a payment event are in the **Freezable**, **Error**, or **Incomplete** status.

3. Click **OK**.

The payment event is deleted.

#### Related Topics

For more information on...	See...
How to search for a payment event	<a href="#">Searching for a Payment Event</a> on page 1223

## Viewing Payments Created Through a Payment Event

### Procedure

To view payments created through a payment event:

1. Search for the payment event in the **Payment Event Summary** screen.
2. In the **Search Results** section, click the **Broadcast**  icon corresponding to the payment event whose payments you want to view.

The **Payments** zone appears.

3. View all payments created through the payment event in the **Payments** zone.

### Related Topics

For more information on...	See...
How to search for a payment event	<a href="#">Searching for a Payment Event</a> on page 1223
<b>Payments</b> zone	<a href="#">Payments</a> on page 1221

## Canceling a Payment

### Prerequisites

To cancel a payment of a payment event, you should have:

- Payment cancel reasons defined in the application

### Procedure

To cancel a payment of a payment event:

1. Search for the payment event in the **Payment Event Summary** screen.
2. In the **Search Results** section, click the **Broadcast**  icon corresponding to the payment event whose payment you want to cancel.

The **Payments** zone appears.

3. Select the check box corresponding to the payment that you want to cancel.
4. Click **Cancel** in the **Payments** zone.

The **Payment Cancel** window appears. It contains the following fields:

Field Name	Field Description	Mandatory (Yes or No)
Cancel Reason	Used to indicate the reason why you want to cancel the payment.	Yes

**Note:** You can cancel a payment only when it is in the **Frozen** status.

5. Select the cancel reason from the respective list.
6. Click **OK**.

The status of the payment is changed to **Canceled**.

### Related Topics

For more information on...	See...
How to search for a payment event	<a href="#">Searching for a Payment Event</a> on page 1223
<b>Payments</b> zone	<a href="#">Payments</a> on page 1221

## Deleting a Payment

### Procedure

To delete a payment of a payment event:

1. Search for the payment event in the **Payment Event Summary** screen.
2. In the **Search Results** section, click the **Broadcast**  icon corresponding to the payment event whose payment you want to delete.

The **Payments** zone appears.

3. Select the check box corresponding to the payment that you want to delete.
4. Click **Delete** in the **Payments** zone.

A message appears confirming whether you want to delete the payment.

**Note:** You can delete a payment only when it is in the **Freezable** or **Error** status.

5. Click **OK**.

The payment is deleted.



### Related Topics

For more information on...	See...
How to search for a payment event	<a href="#">Searching for a Payment Event</a> on page 1223
<b>Payments</b> zone	<a href="#">Payments</a> on page 1221

## Viewing Payment Segments of a Payment

### Procedure

To view payment segments of a payment:

1. Search for the payment event (whose payment details you want to view) in the **Payment Event Summary** screen.
2. In the **Search Results** section, click the **Broadcast**  icon corresponding to the payment event whose payments you want to view.  
The **Payments** zone appears.
3. Click the **Broadcast**  icon corresponding to the payment whose payment segments you want to view.  
The **Payment Segments** zone appears.
4. View the payment segments of the payment in the **Payment Segments** zone.

### Related Topics

<b>For more information on...</b>	<b>See...</b>
How to search for a payment event	<a href="#">Searching for a Payment Event</a> on page 1223
<b>Payment Segments</b> zone	<a href="#">Payment Segments</a> on page 1223



---

# Chapter 18

---

## Account Receivable Central

---

### Topics:

- [Single Offset](#)
- [Mass Offset](#)
- [Cross Currency Offset](#)
- [Hold](#)
- [Refund](#)
- [Write Off](#)
- [Dispute](#)
- [Account Receivable Central](#)

The Account Receivable Central is a portal which facilitates user to perform Single/Mass/Cross Currency offset operation for a bill's outstanding amount with another bill or multiple bills. You can also refund/write off amount to the account using refund requests and write off requests respectively.

Account Receivable Central also enables to put bill(s) on hold for the funding purpose. It allows you to have a complete overview of the bills. Based on the search criteria, the system returns a list of bills that meet the search criteria.

Account Receivable Central is used for:

- **Single Offset** - Enables single debit bill to be offset against multiple credit bills in the same currency and vice versa.
- **Mass Offset** - Enables credit/debit bills to be offset against multiple debit and credit bills in the same currency.
- **Cross Currency Offset** - Enables single debit bills to be offset against multiple credit bills in currencies other than the bill selected for offset and vice versa.
- **Hold** - Enables bill(s) to be put on hold fully (the bill outstanding amount) or partially (the bill outstanding amount in partial) for a specific period for funding.
- **Refund** - Enables you to refund amount of credit bill or bill line item (credit bill segment or adjustment) to the account through a refund request.
- **Write Off** - Enables you to write off amount to the account through a write off request.
- **Dispute** - Enables you to dispute amount of credit/debit bill or bill item (credit/debit bill segment or adjustment) to the account through a dispute request.

The bill(s) for offsetting can belong to the same person or multiple persons depending upon the option **Allow Offsetting across Persons** set in the feature configuration **C1-OFFSETREQ** which allows offsetting in the system.

## Single Offset

Single Offset enables you to search and add bill to an offset request from the **Account Receivable Central** screen. Single Offset enables single debit bill to be offset against multiple credit bills in the same currency and vice versa. The offset request is created and an offset request ID is generated for the request.

You can search and select credit/debit bills (with outstanding amount) for offsetting belonging to the same or different person. All the selected bills with their outstanding balance are displayed. The display of bills is controlled by **C1-OFFSETREQ** feature configuration. The feature configuration identifies whether offsetting is allowed for bills across persons. To offset bills belonging to different persons, set the **Allow Offsetting Across Persons** option type to **Y**. The bills are displayed having same currency with the default offset amount on the offset request after adding the bills. You can select one or multiple or all the bills displayed and add to the offset request. After you add a debit bill from **Account Receivable Central**, you cannot add more debit bills to the offset request.

Upon adding a bill to the offset request, the default offset amount algorithm **C1-OFST-AMT** configured in the offset request type is invoked. The bills in the offset request are processed based on the logic of oldest bill first. The default offset amount is populated against the selected debit and credit bills. You can also edit the offset amount from the offset request, if required. The offset adjustments for offset requests are created and distributed based on the match type set in the offset distribution algorithm.

You can configure the offset request type to be submitted for offset distribution with or without approval. Upon submitting the offset request for approval, a To Do type is created and sent to the approver for offset request approval. The status of the offset request changes from **Submitted** to **Approval In Progress** in case of offset request with approval and in case of offset request without approval it changes to **Processed**. The approver can either approve or reject the offset request. Once the approver approves the offset request, selected bills are offset and adjustments are created for the bills. The status of the offset request changes from **Approval In Progress** to **Processed**. You can also view the details of the adjustment(s) created. However, if the approver rejects an offset request, a rejection reason should be provided.

A log maintained for offset requests logs complete trail of actions performed on offset request except the actions performed while editing the offset request. On submitting, the offset request status changes to **Processed** or **Approval In Progress** depending on the configuration of the offset request type and the **Unapply** button is enabled which cancels the adjustments. Upon cancelling the adjustments, the enter status algorithm cancels the offset adjustments and the status of the request changes to **Unapplied Offset**.

**Note:** The **Unapply** button appears only when the offset request is in the **Processed** status

Bill Information	Original Outstanding Amount	Offset Amount	Remaining Bill Balance	Comments
Bill 1	\$1200	—\$800	\$400	Bill 1 amount \$1200 is offset against Bill 2.
Bill 2	—\$1000	\$500	—\$500	From Bill 2, \$500 is offset against from Bill 1.
Bill 3	—\$300	\$300	0	From Bill 3, \$300 is offset against from Bill 1.

## Mass Offset

Mass offset functions is similar to single offset, the only difference is that mass offset enables credit/debit bills to be offset against multiple debit and credit bills in the same currency.

Upon selection of a debit/credit bill from **Account Receivable Central**, you can add more credit/debit bill(s) from the search bills result in offset request. You can filter the bills using the **Bill Type** filter on the bill search zone to select debit/credit bills to be added to the offset request. While offsetting the credit/debit amount across multiple bills, the oldest bill is offset first.

A log maintained for offset requests logs complete trail of actions performed on offset request. Once you submit the offset request, the offset request status changes to **Processed** or **Approval In Progress** depending on the configuration of the offset request type. When the offset request status changes to **Processed** adjustments are created and the **Unapply** button is enabled which cancels the adjustments. Upon unapplying the offset request, the enter status algorithm cancels the offset adjustments and the status of the request changes to **Unapplied Offset**.

Bill Information	Original Outstanding Amount	Offset Amount	Remaining Bill Balance	Comments
Bill 1	\$2000	—\$700	\$1300	The Offset amount \$400 is offset against Bill 2.
Bill 2	—\$400	\$400	0	Bill 2 is offset against \$400 from Bill Outstanding amount of Bill 1 i.e. \$2000.
Bill 3	—\$300	\$300	0	Bill 3 is offset against \$300 from Bill Outstanding amount of Bill 1 i.e. \$1600.

## Cross Currency Offset

Enables single debit bills to be offset against multiple credit bills in currencies other than the bill selected for offset and vice versa. Cross-currency offset enables you to offset credit/debit bills with different currencies. You can add credit/debit bills to the debit/credit bill added from **Account Receivable Central**. After you add a debit bill from **Account Receivable Central**, you cannot add more debit bills to the offset request. While offsetting the credit/debit amount across multiple bills, the oldest bill is offset first.

The **C1-OFFSUBENT** algorithm validates whether the sum of debit offset amount is equal to sum of credit offset amount for all bills selected in the offset request. After validation, status of the offset request changes to **Processed** or **Approval In Progress** depending on the configuration of the offset request type.

Bill Information	Outstanding Amount	Outstanding Amount (in Offset currency)	Offset Amount	Remaining Bill Balance	Comments
Bill 1	\$300	\$300	—\$130.1	\$169.9	Outstanding amount \$300 is offset against \$130.1 (£100). (Exchange rate: 1£=1.3\$)
Bill 2	—£100	—\$130.1	\$130.1	0	Outstanding amount £100 (\$130.1) of Bill 2 is offset against \$300 from Bill 1.

**Note:** In case of multiple exchange rates with same date and different timestamps, the latest timestamp is considered.

**Note:** The adjustments are created in the currency of the bill.

## Hold

Account Receivable Central enables bill(s) to be put on hold which belongs to a person's account or all accounts of a particular person. When a bill is put on hold, specific reason must be specified; no funding related activities can be performed for the specified period.

Funding related activities are put on hold from the start date of the hold request. The hold exists till the hold request release date; however you can also release individual bills.

You can only put bills on hold which has **Completed** status. When a person/account is on hold, all the subsequent bills under them are also on hold irrespective of bill status. You can select the bill amount in a bill to be put on hold i.e. you can put the particular bill on hold with partial or full bill amount.

Hold request type is used to define the hold request. In the hold request type, the **Hold Process** is set to **Funding**, which puts hold on only the funding activities of the selected bill belonging to a person or account.

## Refund

---

Enables you to refund amount of credit bill to account through a refund request. For creating a refund request you need to specify the refund request type using which you want to create the refund request. The refund request can be defined with (single level/multi-level) or without approval workflow. An approval profile should be defined for the approval workflow. While defining the refund request type, the adjustment type should be defined for creating refund adjustments.

## Write Off

---

Enables you to write off the amount to the account through a write off request. For creating a write off request you need to specify the write off request type. The write off request can be defined with (single level/multi-level) or without approval workflow. An approval profile should be defined for the approval workflow. While defining the write off request type, the adjustment type should be defined for creating write off adjustments.

## Dispute

---

Enables you to dispute amount of credit/debit bill to an account through a dispute request. For creating a dispute request you need to specify the dispute request type using which you want to create the dispute request. The dispute request can be defined with (single level/multi-level) or without approval workflow. An approval profile should be defined for the approval workflow. While defining the dispute request type, the adjustment type should be defined for creating dispute adjustments.

## Account Receivable Central

---

The **Account Receivable Central** screen allows you to search for bills using various search criteria. This screen consists of the following zones:

- [Search Bill](#) on page 1236

Through the **Account Receivable Central** screen, you can navigate to the following screens:

- [Offset Request \(Used for Viewing\)](#) on page 1287
- [Hold Request \(Used for Viewing\)](#) on page 1528
- [Refund Request](#) on page 1434
- [Write Off Request](#) on page 1467
- [Dispute Request \(Used for Viewing\)](#)

### Search Bill

The **Search Bill** zone allows you to search for bills in the **Accounts Receivable Central** screen using various search criteria. This zone contains the following two sections:

- **Search Criteria** — The **Search Criteria** section contains the following fields:

Field Name	Field Description	Mandatory (Yes or No)
Search By	<p>Used to indicate whether you want to search bills using bill details, using account details or using person details whose account is linked to a particular bill. The valid values are:</p> <ul style="list-style-type: none"> <li>• <b>Person Details</b></li> <li>• <b>Account Details</b></li> <li>• <b>Bill Details</b></li> </ul> <p><b>Note:</b> By default, the <b>Person Details</b> option is selected.</p>	Yes
Person ID	<p>Used to select the person ID based on which you want to search for bills of a person.</p> <p><b>Note:</b> This field appears only when you select the <b>Person Details</b> option from the <b>Search By</b> list. The <b>Search</b>  icon appears corresponding to this field. On clicking the <b>Search</b> icon, the <b>Account Search</b> window appears.</p>	No
Person Hierarchy	<p>Used to indicate whether to display hierarchy of the person linked to a particular bill.</p> <p><b>Note:</b> This field appears only when you select the <b>Person Details</b> option from the <b>Search By</b> list.</p>	No
Person Identifier Type	<p>Used to select the identifier type based on which you want to search for bills of a person.</p> <p><b>Note:</b> This field appears only when you select the <b>Person Details</b> option from the <b>Search By</b> list.</p>	Yes (Conditional)
Person Identifier	<p>Used to specify the value of the person identifier type.</p> <p><b>Note:</b> This field appears only when you select the <b>Person Details</b> option from the <b>Search By</b> list.</p>	Yes (Conditional)
Bills on Hold	<p>Used to indicate whether the bill is on hold. The valid values are:</p> <ul style="list-style-type: none"> <li>• No</li> <li>• Yes</li> </ul>	No

Field Name	Field Description	Mandatory (Yes or No)
Bill Balance	Used to search bills with a particular balance amount. The valid values are: <ul style="list-style-type: none"> <li>• Equal to Zero</li> <li>• Greater Than Zero</li> <li>• Less Than Zero</li> <li>• Not Equal to Zero</li> </ul>	No
Pending Bills	Used to indicate whether the bill is pending.	No
Account ID	Used to search for bills of a particular account. <b>Note:</b> This field appears only when you select the <b>Account Details</b> option from the <b>Search By</b> list.	No
Account Identifier Type	Used to specify the account identifier type of the account whose bill you want to search. <b>Note:</b> This field appears only when you select the <b>Account Details</b> option from the <b>Search By</b> list.	No
Account Identifier	Used to select the account identifier based on which you want to search for bills of a particular account. <b>Note:</b> This field appears only when you select the <b>Account Details</b> option from the <b>Search By</b> list.	No
Bill ID	Used to search a particular bill. <b>Note:</b> This field appears only when you select the <b>Bill Details</b> option from the <b>Search By</b> list.	No
Alternate Bill ID	Used to search a particular bill using the alternate bill ID. <b>Note:</b> This field appears only when you select the <b>Bill Details</b> option from the <b>Search By</b> list.	No
Invoice Currency	Used to search for bills which are billed in a particular currency. <b>Note:</b> This field appears only when you select the <b>Bill Details</b> option from the <b>Search By</b> list.	No
Bill Date From	Used to search bills which are created from a particular date onwards.	No
To	Used to search bills which are created till a particular date.	No
Bill Outstanding Amount From	Used to search bills with a particular minimum outstanding amount.	

Field Name	Field Description	Mandatory (Yes or No)
To	Used to search bills with a particular maximum outstanding amount.	

**Note:** You must specify at least one search criterion while searching for a bill when you select the **Person Details** or **Account Details** option from the **Search By** list.

- **Search Results** — On clicking the **Search** button, the search results appear based on the specified search criteria. The **Search Results** section contains the following columns:

Column Name	Column Description
Bill Information	Displays additional information about the bill. In addition, this column has a context menu which helps in navigating to other screens in the application. <b>Note:</b> It has a link. On clicking the link, the <b>Bill</b> screen appears with the details of the respective bill.
Original Bill Amount	Displays the bill amount when the bill was generated.
Outstanding Amount	Displays the current bill balance amount.
Bill Date	Used to specify the date on which the bill was generated.
Hold Amount	Displays the amount from the bill that is on hold.
Account Information	Displays additional information about the account. In addition, this column has a context menu which helps in navigating to other screens in the application. A tool tip appears when you hover over this column corresponding to the bill. It indicates the Current Balance, Excess Payment and Unapplied Payments and their values. <b>Note:</b> It has a link. On clicking the link, the <b>Account</b> screen appears where you can view the details of the respective bill.
Person Information	Displays additional information about the person. In addition, this column has a context menu which helps in navigating to other screens in the application. <b>Note:</b> It has a link. On clicking the link, the <b>Person</b> screen appears with the details of the respective bill.

This zone contains following buttons:

Button Name	Button Description
Single Offset	Used to add the selected bill with same currency to an offset request.
Mass Offset	Used to add the selected bills with same currency to an offset request.
Cross Currency Offset	Used to add the selected bills with different currency to an offset request.
Hold	Used to add the selected bill to hold request to be put on hold.
Write Off	Used to add the selected bill to a write off request.
Refund	Used to add the selected bill to a refund request.
Dispute	Used to add the selected bill to a dispute request.

### **Related Topics**

For more information on...	See...
How to search for bill	<a href="#">Searching for a Bill</a> on page 1241
How to view the details of a bill	<a href="#">Viewing the Bill Details</a> on page 1242

## Bill Information

The **Bill Information** screen allows you to view detail information of a particular bill.

This screen consists of the following zones:

- [Hold Details](#) on page 1240
- [Offset Details](#) on page 1240
- [Garnishment Details](#) on page 1241
- [Bill Line Items](#) on page 1241

## Offset Details

The **Offset Details** zone displays details of the offset request. This zone contains following columns:

Column Name	Column Description
Offset Request Information	Displays additional information about the offset request. <b>Note:</b> It has a link. On clicking the link, the <b>Offset Request</b> screen appears where you can view the details of the respective offset request.
Offset Amount	Displays the total offset amount.
Creation Mode	Displays the mode of creation for offset request . The valid values are: <ul style="list-style-type: none"> <li>• Automatic</li> <li>• Manual</li> </ul>

## Hold Details

The **Hold Details** zone displays details of the hold request on a bill. This zone contains following columns:

Column Name	Column Description
Hold Request Information	Displays additional information about the hold request. <b>Note:</b> It has a link. On clicking the link, the <b>Hold Request</b> screen appears where you can view the details of the respective hold request.
Status	Indicates the status of the hold request.
Entity	Displays the type of entity.
Hold Entity	Displays additional information about the bill which is put on hold. <b>Note:</b> It has a link. On clicking the link, the <b>Bill</b> screen appears where you can view the details of the respective bill.
Start Date	Displays the start date of the hold request.
End Date	Displays the end date of the hold request.



## Garnishment Details

The **Garnishment Details** zone displays details garnishment details of the offset request. This zone contains following columns:

Column Name	Column Description
Garnishment Contract	Displays additional information about the contract created against the garnishment adjustments. In addition, this column has a context menu which helps in navigating to other screens in the application.  <b>Note:</b> It has a link. On clicking the link, the <b>Contract</b> screen appears where you can view the details of the respective contract.
Garnishment Amount	Displays the total garnishment amount.

## Bill Line Items

The **Bill Line Items** zone displays information about the selected bill's bill line item. This zone contains the following fields:

Field Name	Field Description
Bill Line Item	Displays the bill line item (bill segment/adjustment) of the selected bills.
Bill Line Item Information	Displays the information about the bill line item.  <b>Note:</b> It has a link. On clicking the link, the <b>Bill Segment</b> screen or <b>Adjustments</b> screen appears with the details of the respective bill line item or adjustments.
Amount	Displays the amount of the bill line item.
Contract Information	Displays additional information about the contract against which the bill segment or adjustment is created. In addition, this column has a context menu which helps in navigating to other screens in the application.  <b>Note:</b> It has a link. On clicking the link, the <b>Contract</b> screen appears where you can view the details of the respective contract.

### Related Topics

For more information on...	See...
How to view the details of a bill	<a href="#">Viewing the Bill Details</a> on page 1242

## Searching for a Bill

### Procedure

To search for a bill:

1. Click the **Menu** link in the **Application** toolbar.  
A list appears.
2. From the **Main** menu, select **Financial** and then click **Account Receivable Central**.  
The **Account Receivable Central** screen appears.

- Enter the search criteria in the **Search Bill** zone.

**Note:** ORMB search engine supports wildcard search, where you can substitute the percentage (%) symbol as a stand in for any word or letter in a search criteria. You can use the '%' wildcard character in all input fields except the date and ID fields. The '%' wildcard character is suffixed automatically at the end of the partial search criteria. Therefore, you may or may not specify the wildcard character at the end of the partial search criteria. However, you have to prefix the wildcard character manually wherever required.

**Note:** The wild card search for searching bill in the **Search Bill** zone is applicable only when you select the **Bill Details** option from the **Search By** list.

- Click **Search**.

A list of bills that meet the search criteria appears in the **Search Results** section.

#### Related Topics

For more information on...	See...
<b>Account Receivable Central</b> screen	<a href="#">Account Receivable Central</a> on page 1236
<b>Search Bill</b> zone	<a href="#">Search Bill</a> on page 1236

## Viewing the Bill Details

#### Procedure

To view the details of a bill:

- Search for the bill in the **Account Receivable Central** screen.
- In the **Search Results** section, click the **Show Context Menu** () icon corresponding to the bill whose details you want to view.  
A menu appears.
- Click the **Go To Bill Information** menu option.  
The **Bill Information** screen appears.
- View the details of the bills in the **Bill Information** screen.

#### Related Topics

For more information on...	See...
<b>Account Receivable Central</b> screen	<a href="#">Account Receivable Central</a> on page 1236
<b>Bill Information</b> screen	<a href="#">Bill Information</a> on page 1240
How to search for a bill	<a href="#">Searching for a Bill</a> on page 1241

---

# Chapter 19

---

## Offset Request

---

### Topics:

- [Single Offset](#)
- [Mass Offset](#)
- [Cross Currency Offset](#)
- [Prerequisites](#)
- [Offset Request \(Without Approval\) Status Transition](#)
- [Offset Request \(With Approval\) Status Transition](#)
- [Algorithms Used in C1-OffsetRequest](#)
- [Additional Algorithms Used in Offset Request](#)
- [Offset Request Type](#)
- [Offset Request \(Used for Searching\)](#)
- [Offset Request \(Used for Viewing\)](#)

Oracle Revenue Management and Billing allows you to offset the credit and debit bills across accounts of the person and/or its hierarchy. However, you can offset bills across person's hierarchy only when the **Allow Offsetting Across Persons** option type of the **C1-OFFSETREQ** feature configuration is set to **Y**.

You can offset a credit bill with a debit bill and vice-versa. You can offset one or more credit bills with one or more debit bills and vice-versa. You can offset the credit and debit bills in the same currency or in the different currencies. The system enables you to offset bills through an offset request. You can create an offset request from the following screens:

- [Account Receivable Central](#) on page 1236
- [Offset Request \(Used for Searching\)](#) on page 1280

You can create the following types of offset request from both the above screens:

- [Single Offset](#) on page 1245
- [Mass Offset](#) on page 1246
- [Cross Currency Offset](#) on page 1249

While creating an offset request, you need to specify an offset request type using which you want to create the offset request. It is the offset request type which helps the system to determine:

- The business object using which the offset request should be created in the system.
- The default adjustment type using which the transfer or offset adjustment should be created in the system.
- The algorithm which helps to calculate default offset amount when a bill is added to the offset request.
- Whether approval is required while offsetting bills through an offset request.
- Whether an offset request must be processed in the deferred mode or in real time (i.e. immediately)
- The maximum search period (in days) that you want to allow while searching bills in an offset request.
- Whether the transfer or offset adjustments should be created while offsetting bills through an offset request.

In addition, while creating an offset request, you need to specify a primary bill for which you want to create the offset request. A primary bill can be a debit

or credit bill. Once the primary bill is added to an offset request, you can never remove it from the offset request.

Once you specify an offset request type and primary bill, the offset request is created in the **Draft** status. You can then add one or more debit or credit bills in the same or different currencies to the offset request depending on whether you want to create single, mass, or cross currency offset request. These bills are called as secondary bills. You can remove a secondary bill from the offset request when it is in the **Draft** status.

Once both the debit and credit bills are added to an offset request, the default offset amount is calculated for each bill. You can then update the offset amount of a bill, if required. Once the offset amount is specified for each bill, you can submit the offset request. On submitting an offset request, the system checks whether the number of financial transactions created for the bills (which are selected in the offset request) exceeds the defer processing count (defined in the respective offset request type). If the number of financial transactions does not exceed the defer processing count, the system creates the transfer or offset adjustments in the **Frozen** status. However, if the number of financial transactions exceeds the defer processing count, the system changes the status of the offset request to **Deferred Processing**. On executing the **Offset Request Periodic Monitor (C1-OFSRQ)** batch, the system considers the offset requests which are in the **Deferred Processing** status. The batch then creates the transfer or offset adjustments for these offset requests in the **Frozen** status.

You can optionally configure the approval process for the offset request. The approver can either approve or reject an offset request based on the observations. The system also enables you to unapply (i.e. cancel) an offset request. On canceling an offset request, the transfer or offset adjustments created for bills through the offset request are canceled.

An offset request goes through various statuses in its lifecycle. For more information about the offset request statuses, see [Offset Request \(Without Approval\) Status Transition](#) on page 1252 and [Offset Request \(With Approval\) Status Transition](#) on page 1253. Note that the lifecycle of an offset request is driven by business object using which the offset request is created. An offset request business object named **C1-OffsetRequest** is shipped with the product. The offset request feature explained in this document is articulated based on the lifecycle and logic defined in the **C1-OffsetRequest** business object.

For more information on how to setup the offset request feature, see [Prerequisites](#) on page 1251.

## Single Offset

Single offset means you can offset one credit bill against multiple debit bills and vice-versa in the same currency. For example, the following bills are created for Garry Smith:

Account	Bill	Due Date	Bill Segment	Contract Type Priority	Bill Segment Amount	Outstanding Bill Amount	Hold Amount
A1	Bill 1	06-18-2018	BS1	10	-\$100	-\$100	-\$20
	Bill 2	06-12-2018	BS2	10	\$30	\$30 (This is because \$20 is already paid.)	\$10
			BS3	20	\$20		
	Bill 3	06-22-2018	BS4	10	\$30	\$30	\$10
	Bill 4	06-28-2018	BS5	20	\$30	\$40	-
			BS6	30	\$10		

The system enables you to offset these bills through a single offset request. While creating a single offset request, you can add the Bill 1 as the primary bill against which you can offset the debit bills – Bill 2, Bill 3, and Bill 4. Note that you can only add completed bills to an offset request. The system then calculates the total credit and debit bill amount which is available for offsetting, as shown below:

Sum of credit bills' amount which is available for offsetting:

$$(-\$100 - (-\$20)) = (-\$100 + \$20) = -\$80$$

Sum of debit bills' amount which is available for offsetting:

$$((\$30 - \$10) + (\$30 - \$10) + (\$40)) = \$80$$

The system considers the credit or debit bills' total whichever is less as the default offset amount. You can change the offset amount of a bill, if required. However, you need to ensure the following:

- Offset amount of the selected bill is not equal to zero
- Total debit offset amount is equal to total credit offset amount in the offset request
- Negative offset amount is specified for the debit bill and positive offset amount is specified for the credit bill
- Offset amount is less than or equal to the current outstanding amount of the bill

**Note:** If you add or remove a bill from the offset request after updating the offset amount, the system overrides the offset amount with the default offset amount. In such scenarios, you have to update the offset amount of the bills once again.

On submitting or approving a single offset request, the system creates the transfer or offset adjustments using the adjustment type which is specified in the offset request. If the **Transfer Adjustment** option is selected in the respective offset request type, the system creates the transfer adjustments in the **Frozen** status. Considering the above example, the system will create the following transfer adjustments for the offset request:

Transfer	Transfer Adjustments
1	<ul style="list-style-type: none"> <li>\$20 transfer adjustment is created for Bill 1 and matched to -\$100 bill segment cancellation (BS1) FT 1</li> <li>-\$20 transfer adjustment is created for Bill 2 and matched to \$30 bill segment (BS2) FT 2</li> </ul>
2	<ul style="list-style-type: none"> <li>\$20 transfer adjustment is created for Bill 1 and matched to -\$100 bill segment cancellation (BS1) FT 1</li> <li>-\$20 transfer adjustment is created for Bill 3 and matched to \$30 bill segment (BS4) FT 4</li> </ul>
3	<ul style="list-style-type: none"> <li>\$30 transfer adjustment is created for Bill 1 and matched to -\$100 bill segment cancellation (BS1) FT 1</li> <li>-\$30 transfer adjustment is created for Bill 4 and matched to \$30 bill segment (BS5) FT 5</li> </ul>
4	<ul style="list-style-type: none"> <li>\$10 transfer adjustment is created for Bill 1 and matched to -\$100 bill segment cancellation (BS1) FT 1</li> <li>-\$10 transfer adjustment is created for Bill 4 and matched to \$10 bill segment (BS6) FT 6</li> </ul>

However, if the **Transfer Adjustment** option is not selected in the respective offset request type, the system creates the offset adjustments in the **Frozen** status. Considering the above example, the system will create the following offset adjustments for the offset request:

- \$80 offset adjustment is created for Bill 1 and matched to -\$100 Bill Segment Cancellation (BS1) FT 1
- \$20 offset adjustment is created for Bill 2 and matched to \$30 bill segment (BS2) FT 2
- \$20 offset adjustment is created for Bill 3 and matched to \$30 bill segment (BS4) FT 4
- \$30 offset adjustment is created for Bill 4 and matched to \$30 bill segment (BS5) FT 5
- \$10 offset adjustment is created for Bill 4 and matched to \$10 bill segment (BS6) FT 6

Similarly, the transfer or offset adjustments are created when the bills are offset across accounts of the person and its hierarchy. The system distributes the amount from the credit bill starting with the oldest due date. For more information on how the offset amount is distributed, see [CI-OFST-DIST](#) on page 1257.

You can create a single offset request through the **Account Receivables Central** and **Offset Request** screens. For more information on how to create a single offset request, see [Creating an Offset Request](#) on page 1284.

## Mass Offset

Mass offset means you can offset one or more credit bills against one or more debit bills and vice-versa in the same currency. For example, the following bills are created for Juliet Hurd:

Account	Bill	Due Date	Bill Segment	Contract Type Priority	Bill Segment Amount	Outstanding Bill Amount	Hold Amount
A11	Bill 1	01-15-2019	BS1	10	-\$50	-\$100	-
			BS2	20	-\$50		

Account	Bill	Due Date	Bill Segment	Contract Type Priority	Bill Segment Amount	Outstanding Bill Amount	Hold Amount
	Bill 2	01-20-2019	BS3	10	-\$50	-\$50	-
	Bill 3	01-18-2019	BS4	10	\$30	\$50	-
			BS5	10	\$20		
A12	Bill 4	01-21-2019	BS6	10	\$30	\$30	-
	Bill 5	01-25-2019	BS7	20	\$30	\$40	-
			BS8	30	\$10		
A13	Bill 6	01-29-2019	BS9	10	\$20	\$20	-

The system enables you to offset these bills through a mass offset request. While creating a mass offset request, you can add the Bill 1 as the primary bill. Once the offset request is created, you can add another credit bill (i.e. Bill 2) and the debit bills – Bill 3, Bill 4, Bill 5, and Bill 6. Note that you can only add completed bills to an offset request. The system then calculates the total credit and debit bill amount which is available for offsetting, as shown below:

Sum of credit bills' amount which is available for offsetting:

$$(-\$100 + (-\$50)) = (-\$100 - \$50) = -\$150$$

Sum of debit bills' amount which is available for offsetting:

$$(\$50 + \$30 + \$40 + \$20) = \$140$$

The system considers the credit or debit bills' total whichever is less as the default offset amount. In this case, the default offset amount is set to \$140. You can change the offset amount of a bill, if required. However, you need to ensure the following:

- Offset amount of the selected bill is not equal to zero
- Total debit offset amount is equal to total credit offset amount in the offset request
- Negative offset amount is specified for the debit bill and positive offset amount is specified for the credit bill
- Offset amount is less than or equal to the current outstanding amount of the bill

**Note:** If you add or remove a bill from the offset request after updating the offset amount, the system overrides the offset amount with the default offset amount. In such scenarios, you have to update the offset amount of the bills once again.

On submitting or approving a mass offset request, the system creates the transfer or offset adjustments using the adjustment type which is specified in the offset request. If the **Transfer Adjustment** option is selected in the respective offset request type, the system creates the transfer adjustments in the **Frozen** status. Considering the above example, the system will create the following transfer adjustments for the offset request:

Transfer	Transfer Adjustments
1	<ul style="list-style-type: none"> <li>• \$30 transfer adjustment is created for Bill 1 and matched to -\$50 bill segment cancellation (BS1) FT 1</li> <li>• -\$30 transfer adjustment is created for Bill 3 and matched to \$30 bill segment (BS4) FT 4</li> </ul>

Transfer	Transfer Adjustments
2	<ul style="list-style-type: none"> <li>• \$20 transfer adjustment is created for Bill 1 and matched to -\$50 bill segment cancellation (BS1) FT 1</li> <li>• -\$20 transfer adjustment is created for Bill 3 and matched to \$20 bill segment (BS5) FT 5</li> </ul>
3	<ul style="list-style-type: none"> <li>• \$30 transfer adjustment is created for Bill 1 and matched to -\$50 bill segment cancellation (BS2) FT 2</li> <li>• -\$30 transfer adjustment is created for Bill 4 and matched to \$30 bill segment (BS6) FT 6</li> </ul>
4	<ul style="list-style-type: none"> <li>• \$20 transfer adjustment is created for Bill 1 and matched to -\$50 bill segment cancellation (BS2) FT 2</li> <li>• -\$20 transfer adjustment is created for Bill 5 and matched to \$30 bill segment (BS7) FT 7</li> </ul>
5	<ul style="list-style-type: none"> <li>• \$10 transfer adjustment is created for Bill 2 and matched to -\$50 bill segment cancellation (BS3) FT 3</li> <li>• -\$10 transfer adjustment is created for Bill 5 and matched to \$30 bill segment (BS7) FT 7</li> </ul>
6	<ul style="list-style-type: none"> <li>• \$10 transfer adjustment is created for Bill 2 and matched to -\$50 bill segment cancellation (BS3) FT 3</li> <li>• -\$10 transfer adjustment is created for Bill 5 and matched to \$10 bill segment (BS8) FT 8</li> </ul>
7	<ul style="list-style-type: none"> <li>• \$20 transfer adjustment is created for Bill 2 and matched to -\$50 bill segment cancellation (BS3) FT 3</li> <li>• -\$20 transfer adjustment is created for Bill 6 and matched to \$20 bill segment (BS9) FT 9</li> </ul>

However, if the **Transfer Adjustment** option is not selected in the respective offset request type, the system creates the offset adjustments in the **Frozen** status. Considering the above example, the system will create the following offset adjustments for the offset request:

- \$50 offset adjustment is created for Bill 1 and matched to -\$50 Bill Segment Cancellation (BS1) FT 1
- \$50 offset adjustment is created for Bill 1 and matched to -\$50 Bill Segment Cancellation (BS2) FT 2
- \$40 offset adjustment is created for Bill 2 and matched to -\$50 Bill Segment Cancellation (BS3) FT 3
- -\$30 offset adjustment is created for Bill 3 and matched to \$30 bill segment (BS4) FT 4
- -\$20 offset adjustment is created for Bill 3 and matched to \$20 bill segment (BS5) FT 5
- -\$30 offset adjustment is created for Bill 4 and matched to \$30 bill segment (BS6) FT 6
- -\$30 offset adjustment is created for Bill 5 and matched to \$30 bill segment (BS7) FT 7
- -\$10 offset adjustment is created for Bill 5 and matched to \$10 bill segment (BS8) FT 8
- -\$20 offset adjustment is created for Bill 6 and matched to \$20 bill segment (BS9) FT 9

Similarly, the transfer or offset adjustments are created when the bills are offset across accounts of the person hierarchy. The system distributes the amount from the credit bill starting with the oldest due date. For more information on how the offset amount is distributed, see [CI-OFST-DIST](#) on page 1257.



You can create a mass offset request through the **Account Receivables Central** and **Offset Request** screens. For more information on how to create a mass offset request, see [Creating an Offset Request](#) on page 1284.

## Cross Currency Offset

Cross currency offset means you can offset one credit bill against multiple debit bills and vice-versa in the different currencies. For example, the following bills are created for Mark Forbes:

Account	Bill	Due Date	Bill Segment	Contract Type Priority	Bill Segment Amount	Outstanding Bill Amount	Hold Amount
A1	Bill 1	09-18-2018	BS1	10	-\$250	-\$250	-
	Bill 2	09-12-2018	BS2	10	€10	€30	-
			BS3	20	€20		
	Bill 3	09-22-2018	BS4	10	€50	€50	-
	Bill 4	09-28-2018	BS5	20	€30	€70	-
			BS6	30	€40		

The system enables you to offset these bills through a cross currency offset request. While creating a cross currency offset request, you can add the Bill 1 as the primary bill against which you can offset the debit bills – Bill 2, Bill 3, and Bill 4. Note that you can only add completed bills to an offset request. In a cross currency offset request, you can offset the bills which are in the currency different from the primary bill. For example, if you have added a primary bill with credit balance in USD, you can only add the debit bills in the currency other than USD. The system then calculates the total credit and debit bill amount which is available for offsetting, as shown below:

Sum of credit bills' amount which is available for offsetting:

-\$250

Sum of credit bills' amount which is available for offsetting (in offset currency):

-€227

Sum of debit bills' amount which is available for offsetting:

(30€+50€+70€)=€150

Sum of debit bills' amount which is available for offsetting (in offset currency):

\$33+\$55+\$77=\$165

The system considers the credit or debit bills' total (in the primary bill's currency) whichever is less as the default offset amount. In this case, the default offset amount is set to \$165. You can change the offset amount of a bill, if required. However, you need to ensure the following:

- Offset amount of the selected bill is not equal to zero
- Total debit offset amount is equal to total credit offset amount in the offset request
- Negative offset amount is specified for the debit bill and positive offset amount is specified for the credit bill
- Offset amount is less than or equal to the current outstanding amount of the bill

**Note:** If you add or remove a bill from the offset request after updating the offset amount, the system overrides the offset amount with the default offset amount. In such scenarios, you have to update the offset amount of the bills once again.

On submitting or approving a cross currency offset request, the system creates the transfer or offset adjustments using the adjustment type which is specified in the offset request. If the **Transfer Adjustment** option is selected in the respective offset request type, the system creates the transfer adjustments in the **Frozen** status. Considering the above example, the system will create the following transfer adjustments for the offset request:

Transfer	Transfer Adjustments
1	<ul style="list-style-type: none"> <li>\$11 transfer adjustment is created for Bill 1 and matched to -\$250 bill segment cancellation (BS1) FT 1</li> <li>-€10 transfer adjustment is created for Bill 2 and matched to €10 bill segment (BS2) FT 2</li> </ul>
2	<ul style="list-style-type: none"> <li>\$22 transfer adjustment is created for Bill 1 and matched to -\$250 bill segment cancellation (BS1) FT 1</li> <li>-€20 transfer adjustment is created for Bill 2 and matched to €20 bill segment (BS3) FT 3</li> </ul>
3	<ul style="list-style-type: none"> <li>\$55 transfer adjustment is created for Bill 1 and matched to -\$250 bill segment cancellation (BS1) FT 1</li> <li>-€50 transfer adjustment is created for Bill 3 and matched to €50 bill segment (BS4) FT 4</li> </ul>
4	<ul style="list-style-type: none"> <li>\$33 transfer adjustment is created for Bill 1 and matched to -\$250 bill segment cancellation (BS1) FT 1</li> <li>-€30 transfer adjustment is created for Bill 4 and matched to €30 bill segment (BS5) FT 5</li> </ul>
5	<ul style="list-style-type: none"> <li>\$44 transfer adjustment is created for Bill 1 and matched to -\$250 bill segment cancellation (BS1) FT 1</li> <li>-€40 transfer adjustment is created for Bill 4 and matched to €40 bill segment (BS6) FT 6</li> </ul>

However, if the **Transfer Adjustment** option is not selected in the respective offset request type, the system creates the offset adjustments in the **Frozen** status. Considering the above example, the system will create the following offset adjustments for the offset request:

- \$165 offset adjustment is created for Bill 1 and matched to -\$250 Bill Segment Cancellation (BS1) FT 1
- €10 offset adjustment is created for Bill 2 and matched to €10 bill segment (BS2) FT 2
- €20 offset adjustment is created for Bill 2 and matched to €20 bill segment (BS3) FT 3
- €50 offset adjustment is created for Bill 3 and matched to €50 bill segment (BS4) FT 4
- €30 offset adjustment is created for Bill 4 and matched to €30 bill segment (BS5) FT 5
- €40 offset adjustment is created for Bill 4 and matched to €40 bill segment (BS6) FT 6

Similarly, the transfer or offset adjustments are created when the bills are offset across accounts of the person and its hierarchy. The system distributes the amount from the credit bill starting with the oldest due date. For more information on how the offset amount is distributed, see [CI-OFST-DIST](#) on page 1257.

To use the cross currency offset request feature, you need to do the following:

- Define the required exchange rates in the system.
- Define a currency conversion algorithm for bill segments using the **C1\_CURALGBS** or **C1\_EXCRTBS** algorithm type and attach it to the **Currency Conversion For Bill Segments** algorithm spot of the required divisions.

- Define a currency conversion algorithm for adjustments using the **C1\_CURALGAD** or **C1\_EXCRTAD** algorithm type and attach it to the **Currency Conversion For Adjustments** algorithm spot of the required divisions.

You can create a cross currency offset request through the **Account Receivables Central** and **Offset Request** screens. For more information on how to create a cross currency offset request, see [Creating an Offset Request](#) on page 1284.

## Prerequisites

---

To setup the offset request feature, you need to do the following:

- Define the required offset adjustment types where the **A/P Request Type Code** field is not set to **REFUND**.
- Define a default offset amount algorithm using the **C1-OFST-AMT** algorithm type.
- Assign the **C1-OFSRQ** To Do type to a To Do role whose users must receive a To Do while submitting an offset request for approval.
- Assign the **C1-OFSSB** To Do type to a To Do role whose users must not approve an offset request.
- Define the required offset request types in the system.
- Define the required characteristic types where the characteristic entity is set to **Offset Request Type**.
- Define the required characteristic types where the characteristic entity is set to **Offset Request**.
- Define the values for the **CAN\_RSN\_CD\_FLG** lookup field.
- Set the parameters of the **C1-UPD-FUND**, **C1-DFRUNAPLY**, **C1-WTBS-CRBL**, and **C1-OFST-DIST** algorithms.
- Define the status reasons for the **Rejected** and **Unapplied Offset** statuses of the **C1-OffsetRequest** business object in the **Status Reason** screen.
- Set the **Allow Offsetting Across Persons** option type of the **C1-OFFSETREQ** feature configuration.
- Define the required exchange rates in the system.
- Define a currency conversion algorithm for bill segments using the **C1\_CURALGBS** or **C1\_EXCRTBS** algorithm type.
- Attach a currency conversion algorithm to the **Currency Conversion For Bill Segments** algorithm spot of the required divisions.
- Define a currency conversion algorithm for adjustments using the **C1\_CURALGAD** or **C1\_EXCRTAD** algorithm type.
- Attach a currency conversion algorithm to the **Currency Conversion For Adjustments** algorithm spot of the required divisions.
- Set the batch control type of the **Offset Request Periodic Monitor (C1-OFSRQ)** batch to **Timed** and define the following attributes:
  - Time Interval
  - Timer Active
  - User ID
  - Batch Language
  - Email Address

For more information about the **Offset Request Periodic Monitor (C1-OFSRQ)** batch, see *Oracle Revenue Management and Billing Batch Guide*.

### Related Topics

For more information on...	See...
How to setup the <b>C1-OFFSETREQ</b> feature configuration	<a href="#">Setting the C1-OFFSETREQ Feature Configuration</a> on page 2917
<b>C1-OFST-AMT</b> algorithm	<a href="#">C1-OFST-AMT</a> on page 1259
<b>C1-UPD-FUND</b> algorithm	<a href="#">C1-UPD-FUND</a> on page 1258
<b>C1-DFRUNAPLY</b> algorithm	<a href="#">C1-DFRUNAPLY</a> on page 1258
<b>C1-WTBS-CRBL</b> algorithm	<a href="#">C1-WTBS-CRBL</a> on page 1259
<b>C1-OFST-DIST</b> algorithm	<a href="#">C1-OFST-DIST</a> on page 1257
<b>C1_CURALGBS</b> algorithm	<a href="#">C1_CURALGBS</a> on page 814
<b>C1_EXCRTBS</b> algorithm	<a href="#">C1_EXCRTBS</a> on page 821
<b>C1_CURALGAD</b> algorithm	<a href="#">C1_CURALGAD</a> on page 815
<b>C1_EXCRTAD</b> algorithm	<a href="#">C1_EXCRTAD</a> on page 822

## Offset Request (Without Approval) Status Transition

---

The following figure graphically indicates how an offset request moves from one status to another when the approval process is not configured in the offset request type:

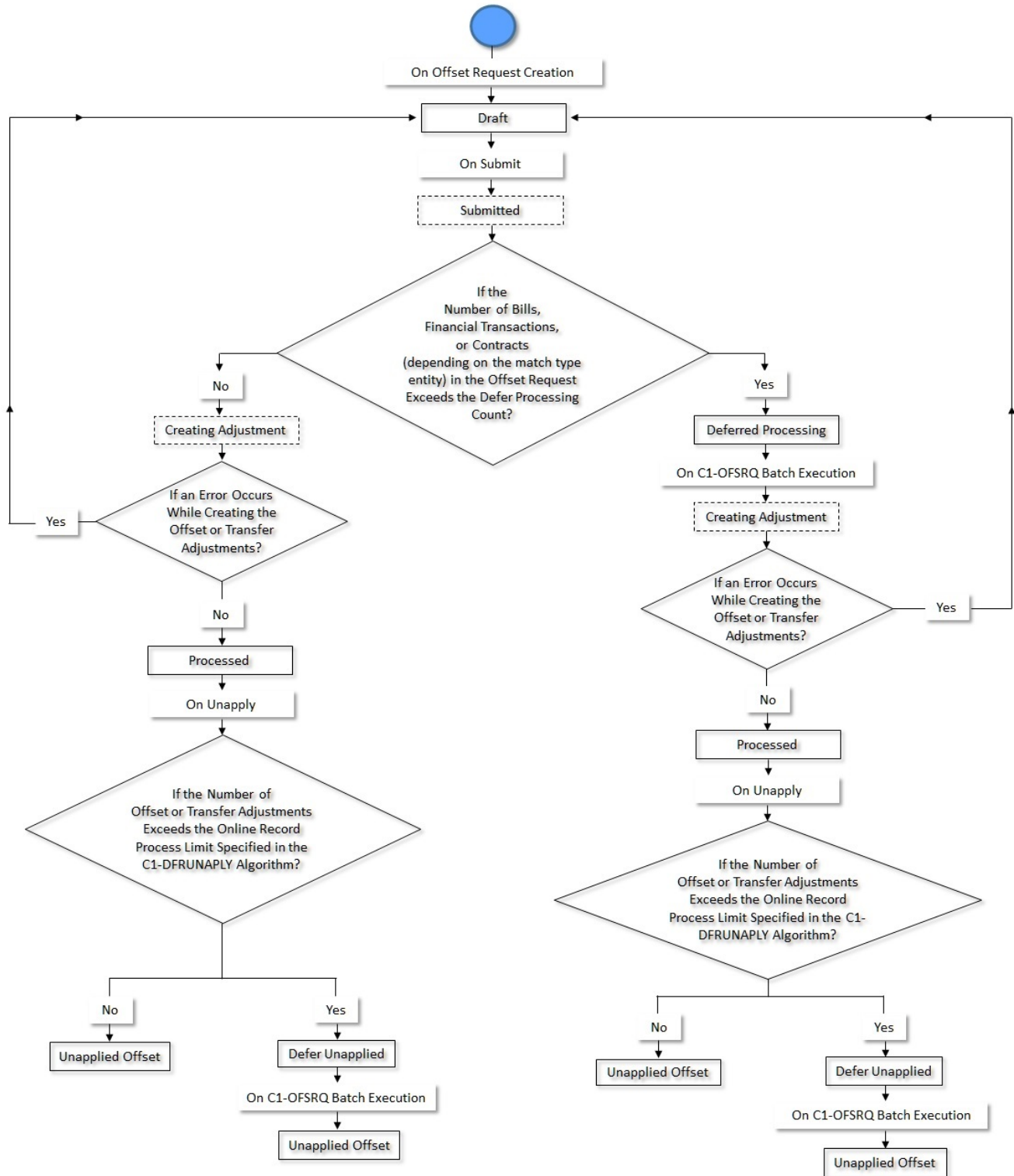

## Offset Request (With Approval) Status Transition

The following figure graphically indicates how an offset request moves from one status to another when the approval process is configured in the offset request type:

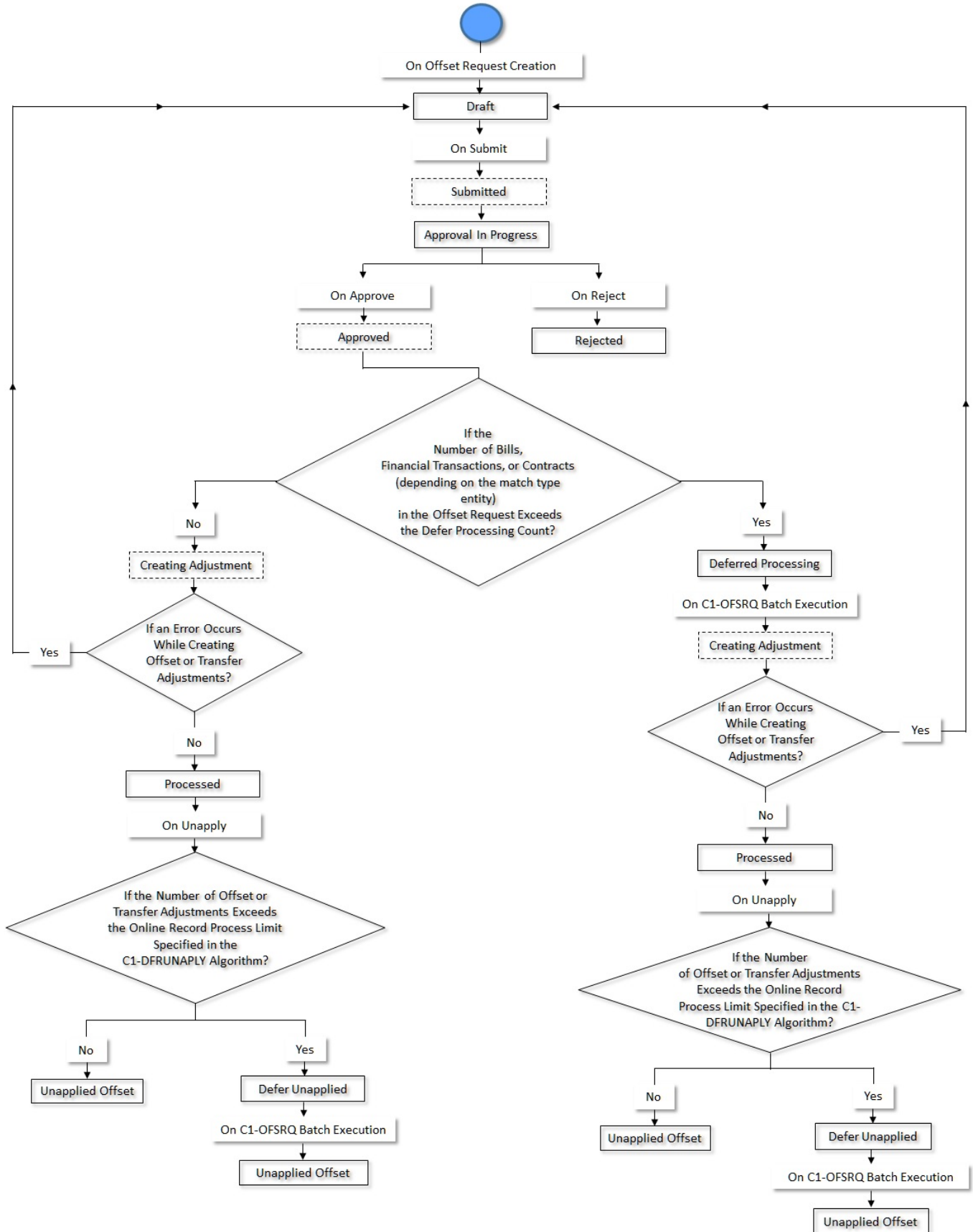

## Algorithms Used in C1-OffsetRequest

The following table lists the algorithm which is attached to the **C1-OffsetRequest** business object:

System Event	Algorithm	Algorithm Type	Description
Information	C1-OFFST-INF	C1-OFFST-INF	Refer to <a href="#">C1-OFFST-INF</a> on page 1256.

The following table lists the algorithms which are used in the lifecycle of the **C1-OffsetRequest** business object:

Status	System Event	Algorithm	Algorithm Type	Description
Draft	Exit	F1-TODOCOMPL	F1-TODOCOMPL	Refer to <a href="#">F1-TODOCOMPL</a> on page 1256.
Submitted	Enter	C1-OFFSUBENT	C1-OFFSUBENT	Refer to <a href="#">C1-OFFSUBENT</a> on page 1256.
Approval In Progress	Enter	C1-OFFAPPENT	C1-OFFAPPENT	Refer to <a href="#">C1-OFFAPPENT</a> on page 1256.
	Exit	C1-OFFAPPEXT	C1-OFFAPPEXT	Refer to <a href="#">C1-OFFAPPEXT</a> on page 1257.
	Exit	F1-TODOCOMPL	F1-TODOCOMPL	Refer to <a href="#">F1-TODOCOMPL</a> on page 1256.
Approved	Enter	C1-OFSAPRENT	C1-OFSAPRENT	Refer to <a href="#">C1-OFSAPRENT</a> on page 1257.
Rejected	-	-	-	-
Deferred Processing	Monitor	F1-AT-RQJ	F1-GEN-BOMNJ	Refer to <a href="#">F1-AT-RQJ</a> on page 1257.
Creating Adjustment	Monitor	F1-AT-RQJ	F1-GEN-BOMNJ	Refer to <a href="#">F1-AT-RQJ</a> on page 1257.
	Enter	C1-OFST-DIST	C1-OFST-DIST	Refer to <a href="#">C1-OFST-DIST</a> on page 1257.
	Enter	C1-UPD-HOLD	C1-UPD-HOLD	Refer to <a href="#">C1-UPD-HOLD</a> on page 1258.
	Enter	C1-UPD-FUND	C1-UPD-FUND	Refer to <a href="#">C1-UPD-FUND</a> on page 1258.
Processed	-	-	-	-
Defer Unapplied	Monitor	F1-AT-RQJ	F1-GEN-BOMNJ	Refer to <a href="#">F1-AT-RQJ</a> on page 1257.

Status	System Event	Algorithm	Algorithm Type	Description
	Enter	C1-DFRUNAPLY	C1-DFRUNAPLY	Refer to <a href="#">C1-DFRUNAPLY</a> on page 1258.
Unapplied Offset	Enter	C1-UNAPOFST	C1-UNAPOFST	Refer to <a href="#">C1-UNAPOFST</a> on page 1259.
	Enter	C1-UPDT-FUND	C1-UPDT-FUND	Refer to <a href="#">C1-UPDT-FUND</a> on page 1259.

## C1-OFFST-INF

This algorithm generates the offset request information string which appears throughout the application. It concatenates the following fields separated by a comma in the specified order:

1. Offset Request Type Description
2. Offset Request Status Description
3. Offset Request ID

## F1-TODOCOMPL

This algorithm completes To Do entries that are created for the business object when the business object exits the given status. It finds and completes all open To Do entries where the business object's primary key is defined as a drill key. However, if the **Exclude To Do Entries From Auto Completion** characteristic is set to **Y** for the business object, the system does not automatically complete the respective To Do entry.

## C1-OFFSUBENT

This algorithm is invoked when you click the **Submit** button. It validates the following:

- Whether the outstanding amount of the selected bills is not zero
- Whether the selected bills are in the **Complete** status
- Whether the overridden offset amount of a bill is not zero
- Whether the sum of the debit bills' offset amount is equal to the sum of the credit bills' offset amount
- Whether at least one debit and credit bills are selected in the offset request

If the validation is successful, it checks whether the **Approval Required** option is selected in the respective offset request type. If the **Approval Required** option is selected in the respective offset request type, it changes the status of the offset request to **Approval In Progress**. However, if the **Approval Required** option is not selected in the respective offset request type, it checks whether the number of financial transactions created for the bills, which are selected in the offset request, exceeds the defer processing count. If the number of financial transactions does not exceed the defer processing count, the system changes the status of the offset request to **Creating Adjustment**. However, if the number of financial transactions exceeds the defer processing count, the system changes the status of the offset request to **Deferred Processing**.

## C1-OFFAPPENT

This algorithm is invoked when the status of the offset request is changed to **Approval In Progress**. It creates a To Do using the approval To Do type which is specified in the respective offset request type. Once a To Do is created, it is assigned to all users with the approval To Do role which is specified in the respective offset request type. In addition, it creates a log entry for the offset request when the To Do is created.



## C1-OFFAPPEXT

This algorithm checks whether the approver is associated with the approval To Do role which is specified in the respective offset request type. If so, it allows the approver to approve or reject the offset request. It also ensures that the submitter does not approve or reject the offset request.

## C1-OFSAPRENT

This algorithm is invoked when you click the **Approve** button. It checks whether the number of financial transactions created for the bills, which are selected in the offset request, exceeds the defer processing count. If the number of financial transactions does not exceed the defer processing count, the system changes the status of the offset request to **Creating Adjustment**. However, if the number of financial transactions exceeds the defer processing count, the system changes the status of the offset request to **Deferred Processing**.

## F1-AT-RQJ

This algorithm transitions the current status of the business object to the specified status. It contains the following parameters:

- **Next Status** – Used when you want to override the default next status specified in the lifecycle.
- **Next Transition Condition** – Used when you want to override the default next transition condition specified in the lifecycle.

At a time, you can specify value for either the **Next Status** or **Next Transition Condition** parameter. If you don't specify any value for these parameters, the system will transition the business object to the default next status specified in its lifecycle.

## C1-OFST-DIST

This algorithm is invoked when the status of the offset request is changed to **Creating Adjustment**. It creates offset adjustments using the adjustment type specified in the offset request and sets the status of the offset adjustments to **Frozen**. If the **Transfer Adjustment** option is selected in the respective offset request type, it creates transfer adjustments in the **Frozen** status.

This algorithm distributes the offset amount of a bill in the following manner:

1. **Internal Offsetting Within Each Bill** - This happens when a bill contains both debit and credit line items. The internal offsetting happens either at the bill segment or contract level depending on the value specified in the **Match Type Entity (Valid Values: BILL, BSEG, SA)** parameter. If the **Match Type Entity (Valid Values: BILL, BSEG, SA)** parameter is set to **BILL** or **SA**, the internal offsetting happens at the contract level. However, if the **Match Type Entity (Valid Values: BILL, BSEG, SA)** parameter is set to **BSEG**, the internal offsetting happens at the bill segment level. In the bill, the internal offsetting is done starting from a credit contract with highest payment priority against a debit contract with highest payment priority by creating transfer adjustments. This continues until the sum of credit or debit amount within a bill is exhausted.
2. **Offsetting Across Debit and Credit Bills** - This offsetting is always done from the credit bills to the debit bills with the objective to reduce the debit bill balance. This algorithm checks whether any match event is created for the bill. If so, it creates the offset adjustments against the bill using the existing match event. If there are no match events created for the bill, this algorithm creates match events using the value specified in the **Match Type Entity (Valid Values: BILL, BSEG, SA)** parameter. It distributes the amount from the credit bill starting with the oldest due date. This continues until the credit bill balance is exhausted.

It contains the following parameters:

- **Match Type** - Used to specify the match type using which you want to distribute the offset amount. You must specify a match type where the payment distribution override algorithm is attached.

**Note:** If a bill which is offset is partially paid using a match type, this algorithm uses the same match type for offset distribution. However, if no payment is received for a bill which is offset, this algorithm uses the match type which is specified in the **Match Type** parameter for offset distribution.

- **Match Type Entity (Valid Values: BILL, BSEG, SA)** - Used to indicate the entity, such as bill, bill segment, or contract, against which you want to create match event. It is used to create match events for bills which are unpaid. The valid values are:
  - **BILL** - Used when you want to stamp same match event on all financial transactions of the bill.
  - **BSEG** - Used when you want to stamp unique match event on each bill segment or adjustment financial transaction.
  - **SA** - Used when you want to stamp same match event on all financial transactions which are created for the same contract.
- **Credit Bill Distribution Algorithm** - Used to specify an algorithm which helps to create offset adjustments for a credit bill at the bill segment level. This parameter is required when the **Transfer Adjustment** option is not selected in the respective offset request type.

**Note:** The **C1-WTBS-CRBL** algorithm type is shipped with the product. You can attach an algorithm created using the **C1-WTBS-CRBL** algorithm type to the **Credit Bill Distribution Algorithm** parameter. For more information, see [C1-WTBS-CRBL](#) on page 1259.

## C1-UPD-HOLD

This algorithm updates the hold request whenever a bill on hold is offset through an offset request. If the remaining outstanding amount of a bill after offsetting is not zero and is less than the current hold amount, this algorithm updates the hold amount to the current hold amount plus remaining outstanding bill balance. For example, if the original outstanding amount is 80\$, hold amount is 40\$, offset amount is 20\$, then the remaining outstanding amount (i.e.  $80\$ - 40\$ - 20\$ = 20\$$ ) is less than the current hold amount (i.e. 40\$). Therefore, this algorithm updates the hold amount of the bill in the hold request to 60\$ (i.e.  $40\$ + 20\$$ ).

However, if the remaining outstanding amount of a bill after offsetting is zero and the bill is included in any active hold request, the hold end date of the bill in the hold request is changed to the system date.

In both the above scenarios, this algorithm creates a log entry for the offset and hold requests. The bill whose hold details (i.e. either hold amount or hold end date) are updated through the offset request is maintained in its log. Similarly, the old and updated hold amount and hold end date of the bill are maintained in the respective hold request log.

## C1-UPD-FUND

If a bill which is offset through an offset request is present in a funding request which is in the **Draft** status, this algorithm updates the funding amount of the bill in the funding request. If entire sum of the funding and garnishment amount of a bill is offset through the offset request, the bill is excluded from the funding request.

It contains the following parameter:

- **Funding Exclusion Reason Code** - Used to indicate the reason why you want to exclude the bill from the funding request. This parameter is mandatory while excluding a bill from a funding request. You must specify a value which is already defined in the **CAN\_RSN\_CD\_FLG** lookup field.

## C1-DFRUNAPLY

This algorithm is invoked when you click the **Unapply** button. It checks whether the number of transfer or offset adjustments created through the offset request exceeds the online record process limit defined in this algorithm. If the number of transfer or offset adjustments does not exceed the online record process limit, the system cancels the frozen transfer or offset adjustments immediately and then changes the status of the offset request to **Unapplied Offset**. However, if the number of transfer or offset adjustments exceeds the online record process limit, the system changes the status of the offset request to **Defer Unapplied**.

It contains the following parameter:

- **Online Record Process Limit** - Used to indicate the maximum number of transfer or offset adjustments you can process in the real time (i.e. immediately).

## C1-UNAPOFST

This algorithm is invoked when the **Offset Request Periodic Monitor (C1-OFSRQ)** batch is executed. It cancels all transfer or offset adjustments created through the offset request and then changes the status of the offset request to **Unapplied Offset**.

## C1-UPDT-FUND

Once the transfer or offset adjustments of a bill are canceled, it checks whether the bill is included in any funding request which is in the **Draft** status. If so, it updates the funding amount of the bill in the respective funding request.

## C1-WTBS-CRBL

THIS ALGORITHM IS ONLY USED IF YOU PRACTICE OPEN-ITEM ACCOUNTING AND THE ACCOUNT'S CUSTOMER CLASS INDICATES OPEN-ITEM ACCOUNTING IS PRACTICED.

This algorithm is used to offset the bill segments of a credit bill. It considers the bill segments of a credit bill for offsetting based on the following parameter:

- **Bill Segment Date Type** – Used to indicate whether the system should consider the bill segments of a credit bill based on the freeze date or coverage start date. The valid values are:
  - **F** – Used when you want to consider the bill segments of a credit bill based on the order of the freeze date.
  - **C** – Used when you want to consider the bill segments of a credit bill based on the order of the coverage start date. Note that you can use this option only when the coverage start date is stamped corresponding to the financial transactions in the **C1\_FT\_EXT** table.

It creates a unique match event for each bill segment and adjustment financial transaction.

## Additional Algorithms Used in Offset Request

---

Besides using the algorithms attached to the lifecycle, the system uses the following algorithms for the **Offset Request** feature:

- [C1-OFST-AMT](#) on page 1259
- [C1-WTBS-CRBL](#) on page 1259

## C1-OFST-AMT

This algorithm calculates the default offset amount whenever a bill is added to the offset request. The default offset amount is equal to the sum of outstanding amount of the debit or credit bills whichever is less. For example, if the following bills are added to the offset request:

- Bill 1 (-100\$) where due date is set to 01-01-2018
- Bill 2 (-100\$) where due date is set to 01-01-2019
- Bill 3 (25\$) where due date is set to 01-01-2018
- Bill 4 (25\$) where due date is set to 06-01-2018

In such case, the system sets the default offset amount of Bill 1 to 50\$.

**Note:** This algorithm does not calculate the default offset amount until both the debit and credit bills are added to the offset request.

## C1-WTBS-CRBL

THIS ALGORITHM IS ONLY USED IF YOU PRACTICE OPEN-ITEM ACCOUNTING AND THE ACCOUNT'S CUSTOMER CLASS INDICATES OPEN-ITEM ACCOUNTING IS PRACTICED.

This algorithm is used to offset the bill segments of a credit bill. It considers the bill segments of a credit bill for offsetting based on the following parameter:

- **Bill Segment Date Type** – Used to indicate whether the system should consider the bill segments of a credit bill based on the freeze date or coverage start date. The valid values are:
  - **F** – Used when you want to consider the bill segments of a credit bill based on the order of the freeze date.
  - **C** – Used when you want to consider the bill segments of a credit bill based on the order of the coverage start date. Note that you can use this option only when the coverage start date is stamped corresponding to the financial transactions in the **C1\_FT\_EXT** table.

It creates a unique match event for each bill segment and adjustment financial transaction.

## Offset Request Type

---

Oracle Revenue Management and Billing allows you to define an offset request type using which you can create an offset request. It is the offset request type which helps the system to determine the following:



- The business object using which the offset request should be created in the system.
- The default adjustment type using which the transfer or offset adjustments should be created in the system.
- The algorithm which helps to calculate default offset amount when a bill is added to the offset request.
- Whether approval is required while offsetting bills through an offset request.
- Whether an offset request must be processed in the deferred mode or in real time (i.e. immediately)
- The maximum search period (in days) that you want to allow while searching bills in an offset request.
- Whether transfer or offset adjustments should be created while offsetting bills through an offset request.

The **Offset Request Type** screen allows you to define, edit, delete, and copy an offset request type. It contains the following zones:

- [Offset Request Type List](#) on page 1260
- [Offset Request Type](#) on page 1261

### Offset Request Type List

The **Offset Request Type List** zone lists the offset request types that are already defined in the system. It contains the following columns:

Column Name	Column Description
Offset Request Type	Displays the offset request type.
Description	Displays the description of the offset request type.
Edit	On clicking the <b>Edit</b> (  ) icon, the <b>Offset Request Type</b> screen appears where you can edit the details of the offset request type.
Duplicate	On clicking the <b>Duplicate</b> (  ) icon, the <b>Offset Request Type</b> screen appears where you can define a new offset request type using an existing offset request type.

Column Name	Column Description
Delete	<p>On clicking the <b>Delete</b> (🗑️) icon, you can delete the offset request type.</p> <p><b>Note:</b> You can delete an offset request type only when an offset request is not created using the offset request type.</p>

On clicking the **Broadcast** (📡) icon corresponding to an offset request type, the **Offset Request Type** zone appears with the details of the respective offset request type.

### Related Topics

For more information on...	See...
How to edit an offset request type	<a href="#">Editing an Offset Request Type</a> on page 1269
How to copy an offset request type	<a href="#">Copying an Offset Request Type</a> on page 1275
How to delete an offset request type	<a href="#">Deleting an Offset Request Type</a> on page 1274
How to view the details of an offset request type	<a href="#">Viewing the Offset Request Type Details</a> on page 1279

## Offset Request Type

The **Offset Request Type** zone displays the details of the offset request type. It contains the following sections:

- **Main** - Displays basic information about the offset request type. It contains the following fields:

Field Name	Field Description
Offset Request Type	Displays the offset request type.
Description	Displays the description of the offset request type.
Offset Request Business Object	<p>Indicates the business object using which an offset request should be created. In addition, a context menu appears corresponding to this field which helps in navigating to other screens in the application.</p> <p><b>Note:</b> It has a link. On clicking the link, the <b>Business Object</b> screen appears where you can view the details of the respective business object.</p>
Detailed Description	Displays additional information about the offset request type.
Status	<p>Indicates the status of the offset request type. The valid values are:</p> <ul style="list-style-type: none"> <li>• Active</li> <li>• Inactive</li> </ul>
Adjustment Type	<p>Indicates the adjustment type using which the transfer or offset adjustments should be created.</p> <p><b>Note:</b> It has a link. On clicking the link, the <b>Adjustment Type</b> screen appears where you can view the details of the respective adjustment type.</p>
Default Offset Amount Algorithm	<p>Indicates the algorithm using which the default offset amount should be calculated while adding a bill in an offset request.</p> <p><b>Note:</b> It has a link. On clicking the link, the <b>Algorithm</b> screen appears where you can view the details of the respective algorithm.</p>

Field Name	Field Description
Defer Processing Count	Displays the count which helps to determine whether an offset request must be processed in the deferred mode (i.e. in the background) or in real time (i.e. immediately).
Approval Required	Indicates whether approval is required while offsetting bills through an offset request.
Approval To Do Type	Indicates that the To Do entry of the specified To Do type must be created when an offset request is submitted for approval.  <div style="border: 1px solid black; padding: 5px;"> <p><b>Note:</b> It has a link. On clicking the link, the <b>To Do Type</b> screen appears where you can view the details of the respective To Do Type. This field appears only when the <b>Approval Required</b> option is selected.</p> </div>
Approval To Do Role	Indicates that users with the specified To Do role can only approve an offset request which is submitted for approval.  <div style="border: 1px solid black; padding: 5px;"> <p><b>Note:</b> It has a link. On clicking the link, the <b>To Do Role</b> screen appears where you can view the details of the respective To Do Role. This field appears only when the <b>Approval Required</b> option is selected.</p> </div>
Submitter To Do Type	Indicates the submitter To Do type. At present, the submitter To Do type is not used to create To Do entry when the approver rejects an offset request. It is only used to fetch the roles associated with the submitter To Do type while defining or editing the offset request type.  <div style="border: 1px solid black; padding: 5px;"> <p><b>Note:</b> It has a link. On clicking the link, the <b>To Do Type</b> screen appears where you can view the details of the respective To Do type.</p> </div>
Submitter To Do Role	Indicates that users with the specified To Do role cannot approve an offset request which is submitted for approval.  <div style="border: 1px solid black; padding: 5px;"> <p><b>Note:</b> It has a link. On clicking the link, the <b>To Do Role</b> screen appears where you can view the details of the respective To Do role.</p> </div>
Bill Search Period	Displays the maximum search period (in days) which is allowed while searching bills in an offset request.
Transfer Adjustment	Indicates whether transfer adjustments should be created while offsetting bills through an offset request.

- **Characteristics** - Lists the characteristics defined for the offset request type. It contains the following columns:

Column Name	Column Description
Characteristic Type	Indicates the characteristic type.
Characteristic Value	Displays the value of the characteristic type.

- **Record Actions** - This section contains the following buttons:

Button Name	Button Description
Edit	Used to edit the details of the offset request type.
Delete	Used to delete the offset request type. <b>Note:</b> You can delete an offset request type only when an offset request is not created using the offset request type.
Duplicate	Used to create a new offset request type using an existing offset request type.

- **Record Information** - This section contains the following field:

Field Name	Field Description
Business Object	Indicates the business object using which the offset request type is created. In addition, a context menu appears corresponding to this field which helps in navigating to other screens in the application. <b>Note:</b> It has a link. On clicking the link, the <b>Business Object</b> screen appears where you can view the details of the respective business object.

By default, the **Offset Request Type** zone does not appear in the **Offset Request Type** screen. It appears only when you click the **Broadcast**  icon corresponding to an offset request type in the **Offset Request Type List** zone.

### **Related Topics**

For more information on...	See...
How to edit an offset request type	<a href="#">Editing an Offset Request Type</a> on page 1269
How to copy an offset request type	<a href="#">Copying an Offset Request Type</a> on page 1275
How to delete an offset request type	<a href="#">Deleting an Offset Request Type</a> on page 1274
How to view the details of an offset request type	<a href="#">Viewing the Offset Request Type Details</a> on page 1279

## **Defining an Offset Request Type**

### **Prerequisites**

To define an offset request type, you should have:

- Offset request type business objects defined in the application
- Offset request business objects defined in the application
- Adjustment types defined in the application (where the **A/P Request Type Code** field is not set to **REFUND**)
- Default offset amount algorithm defined using the **C1-OFST-AMT** algorithm type
- Required To Do role assigned to the **C1-OFSRQ** and **C1-OFSSB** To Do types in the application
- Required match type entity specified in the **Match Type Entity (Valid Values: BILL, BSEG, SA)** parameter of the **C1-OFST-DIST** algorithm

### **Procedure**

To define an offset request type:

1. Click the **Admin** link in the **Application** toolbar.

A list appears.

- From the **Admin** menu, select **O** and then click **Offset Request Type**.

A sub-menu appears.

- Click the **Add** option from the **Offset Request Type** sub-menu.

The **Select Business Object** screen appears. It contains the following field:

Field Name	Field Description	Mandatory (Yes or No)
Offset Request Type Business Object	Used to indicate the business object using which you want to create the offset request type.	Yes

**Tip:** Alternatively, you can access the **Select Business Object** screen by clicking the **Add** button in the **Page Title** area of the **Offset Request Type** screen.

**Note:** The **Select Business Object** screen appears only when there are multiple offset request type business objects defined in the application. If there is only one offset request type business object defined in the application, the **Offset Request Type** screen appears.

- Select the required offset request type business object from the respective field.

- Click **OK**.

The **Offset Request Type** screen appears. It contains the following sections:



- Main** - Used to specify basic details about the offset request type.
- Characteristics** - Used to define characteristics for the offset request type.

The **Main** section contains the following fields:

Field Name	Field Description	Mandatory (Yes or No)
Offset Request Type	Used to specify the offset request type.	Yes
Business Object	Indicates the business object using which you are defining the offset request type.	Not applicable
Description	Used to specify the description for the offset request type.	Yes
Offset Request Business Object	Used to indicate the business object using which you want to create the respective offset request.	Yes
Detailed Description	Used to specify additional information about the offset request type.	No
Status	Used to indicate the status of the offset request type. The valid values are: <ul style="list-style-type: none"> <li>Active</li> <li>Inactive</li> </ul>	Yes

**Note:** You cannot change the status of an offset request type to **Inactive** when the corresponding offset request is in a status other than **Processed**, **Rejected**, or **Unapplied Offset**.



Field Name	Field Description	Mandatory (Yes or No)
Adjustment Type	<p>Used to indicate the adjustment type using which transfer or offset adjustments should be created. By default, the specified adjustment type appears when you create an offset request. You can then change the adjustment type, if required, while editing an offset request.</p> <div data-bbox="591 420 1198 800" style="border: 1px solid black; padding: 5px;"> <p><b>Note:</b></p> <p>The <b>Search</b>  icon appears corresponding to the <b>Adjustment Type</b> field. On clicking the <b>Search</b> icon, the <b>Adjustment Type Search</b> window appears.</p> <p>On specifying the adjustment type, the description of the adjustment type appears corresponding to the <b>Adjustment Type</b> field.</p> <p>You can only specify an adjustment type where the <b>A/P Request Type Code</b> field is not set to <b>REFUND</b>.</p> </div>	Yes
Default Offset Amount Algorithm	<p>Used to attach an algorithm using which you want to calculate default offset amount while adding a bill in an offset request.</p> <div data-bbox="591 940 1198 1346" style="border: 1px solid black; padding: 5px;"> <p><b>Note:</b></p> <p>The <b>Search</b>  icon appears corresponding to the <b>Default Offset Amount Algorithm</b> field. On clicking the <b>Search</b> icon, the <b>Algorithm Search</b> window appears.</p> <p>On specifying the algorithm, the description of the algorithm appears corresponding to the <b>Default Offset Amount Algorithm</b> field.</p> <p>You must specify an algorithm which is created using the <b>C1-OFST-AMT</b> algorithm type in the <b>Default Offset Amount Algorithm</b> field.</p> </div>	Yes

Field Name	Field Description	Mandatory (Yes or No)
Defer Processing FT Count	<p>Used to indicate whether an offset request must be processed in the deferred mode or in real time (i.e. immediately). If the number of financial transactions created for the bills which are selected in the offset request exceeds the defer processing count, the system will process the offset request in the deferred mode. However, if the number of financial transactions created for the bills which are selected in the offset request does not exceed the defer processing count, the system will process the offset request in real time (i.e. immediately).</p> <div data-bbox="591 575 1198 1010" style="border: 1px solid black; padding: 5px;"> <p><b>Note:</b></p> <p>You cannot specify a negative value in this field.</p> <p>Deferred mode means in the background when the <b>Offset Request Periodic Monitor (C1-OFSRQ)</b> batch is invoked. You can configure the <b>Offset Request Periodic Monitor (C1-OFSRQ)</b> batch such that it is executed at regular intervals. For more information about the <b>Offset Request Periodic Monitor (C1-OFSRQ)</b> batch, refer to <i>Oracle Revenue Management and Billing Batch Guide</i>.</p> <p>If you set the defer processing count to zero (0), the system resets the default value to 50.</p> </div>	No
Approval Required	Used to indicate whether approval is required while offsetting bills through an offset request.	No
Approval To Do Type	<p>Used to indicate that To Do entry of the specified To Do type must be created when you submit an offset request for approval.</p> <div data-bbox="591 1230 1198 1724" style="border: 1px solid black; padding: 5px;"> <p><b>Note:</b></p> <p>The <b>Search</b>  icon appears corresponding to the <b>Approval To Do Type</b> field. On clicking the <b>Search</b> icon, the <b>To Do Type Search</b> window appears.</p> <p>On specifying the To Do type, the description of the To Do type appears corresponding to the <b>Approval To Do Type</b> field.</p> <p>This field appears only when the <b>Approval Required</b> option is selected.</p> <p>The <b>C1-OFSRQ</b> To Do type is shipped with the product. You can use the <b>C1-OFSRQ</b> To Do type or a custom To Do type, if required.</p> </div>	<p>Yes (Conditional)</p> <div data-bbox="1219 1167 1463 1314" style="border: 1px solid black; padding: 5px;"> <p><b>Note:</b> This field is required when the <b>Approval Required</b> option is selected.</p> </div>

Field Name	Field Description	Mandatory (Yes or No)
Approval To Do Role	<p>Used to indicate that users with the specified To Do role can only approve an offset request submitted for approval.</p> <p><b>Note:</b> The list includes only those To Do roles which are associated with the approval To Do type. This field appears only when the <b>Approval Required</b> option is selected.</p>	<p>Yes (Conditional)</p> <p><b>Note:</b> This field is required when the <b>Approval Required</b> option is selected.</p>
Submitter To Do Type	<p>At present, the submitter To Do type is not used to create To Do entry when the approver rejects an offset request. It is only used to fetch the roles associated with the submitter To Do type.</p> <p><b>Note:</b> The <b>Search</b>  icon appears corresponding to the <b>Submitter To Do Type</b> field. On clicking the <b>Search</b> icon, the <b>To Do Type Search</b> window appears. On specifying the To Do type, the description of the To Do type appears corresponding to the <b>Submitter To Do Type</b> field. The <b>C1-OFSSB</b> To Do type is shipped with the product. You can use the <b>C1-OFSSB</b> To Do type or a custom To Do type, if required.</p>	<p>Yes (Conditional)</p> <p><b>Note:</b> This field is required when the <b>Approval Required</b> option is selected.</p>
Submitter To Do Role	<p>Used to indicate that users with the specified To Do role cannot approve an offset request submitted for approval.</p> <p><b>Note:</b> The list includes only those To Do roles which are associated with the submitter To Do type.</p>	<p>Yes (Conditional)</p> <p><b>Note:</b> This field is required when the <b>Approval Required</b> option is selected.</p>
Bill Search Period	<p>Used to specify the maximum search period (in days) that you want to allow while searching bills in an offset request.</p> <p><b>Note:</b> If you do not specify any value, by default, it is set to <b>30</b>.</p>	<p>No</p>

Field Name	Field Description	Mandatory (Yes or No)
Transfer Adjustment	<p>Used to indicate whether transfer adjustments should be created while offsetting bills through an offset request.</p> <p><b>Note:</b></p> <p>By default, the <b>Transfer Adjustment</b> option is selected. This impacts the system performance when the match type entity is set to <b>BSEG</b> and volume of bill segments in the selected bills is high. Alternatively, the system enables you to create offset adjustments while offsetting bills through an offset request whenever the volume of bill segments in the selected bills is high. To create the offset adjustments while offsetting bills through an offset request, you need to ensure that the <b>Transfer Adjustment</b> option is not selected in the respective offset request type.</p>	No

6. Enter the required details in the **Main** section.
7. Define characteristics for the offset request type, if required.
8. Click **Save**.

The offset request type is defined.

#### Related Topics

For more information on...	See...
<b>Offset Request Type</b> screen	<a href="#">Offset Request Type</a> on page 1260
How to define a characteristic for an offset request type	<a href="#">Defining a Characteristic for an Offset Request Type</a> on page 1268
<b>C1-OFST-AMT</b> algorithm	<a href="#">C1-OFST-AMT</a> on page 1259

## Defining a Characteristic for an Offset Request Type

### Prerequisites

To define a characteristic for an offset request type, you should have:

- Characteristic types defined in the application (where the characteristic entity is set to **Offset Request Type**).

### Procedure

To define a characteristic for an offset request type:

1. Ensure that the **Characteristics** section is expanded when you are defining, editing, or copying an offset request type.

The **Characteristics** section contains the following fields in a grid:

Field Name	Field Description	Mandatory (Yes or No)
Characteristic Type	Used to indicate the characteristic type.  <b>Note:</b> The list includes only those characteristic types where the characteristic entity is set to <b>Offset Request Type</b> .	Yes (Conditional)  <b>Note:</b> This field is required when you are defining a characteristic for the offset request type.
Characteristic Value	Used to specify the value for the characteristic type.  <b>Note:</b> If you select a predefined characteristic type, the <b>Search</b>  icon appears corresponding to the <b>Characteristic Value</b> field. On clicking the <b>Search</b> icon, the <b>Predefined Characteristic Search</b> window appears.  On specifying the value for a predefined characteristic type, the description of the characteristic value appears corresponding to the <b>Characteristic Value</b> field.	Yes (Conditional)  <b>Note:</b> This field is required when you are defining a characteristic for the offset request type.

- Enter the required details in the **Characteristics** section.
- If you want to define more than one characteristic for the offset request type, click the **Add**  icon and then repeat step 2.

**Note:** However, if you want to remove a characteristic from the offset request type, click the **Delete**  icon corresponding to the characteristic.

### Related Topics

For more information on...	See...
How to define an offset request type	<a href="#">Defining an Offset Request Type</a> on page 1263
How to edit an offset request type	<a href="#">Editing an Offset Request Type</a> on page 1269
How to copy an offset request type	<a href="#">Copying an Offset Request Type</a> on page 1275

## Editing an Offset Request Type

### Prerequisites

To edit an offset request type, you should have:

- Offset request business objects defined in the application
- Adjustment types defined in the application (where the **A/P Request Type Code** field is not set to **REFUND**)
- Default offset amount algorithm defined using the **C1-OFST-AMT** algorithm type
- Required To Do role assigned to the **C1-OFSRQ** and **C1-OFSSB** To Do types in the application
- Required match type entity specified in the **Match Type Entity (Valid Values: BILL, BSEG, SA)** parameter of the **C1-OFST-DIST** algorithm

### Procedure

To edit an offset request type:



1. Click the **Admin** link in the **Application** toolbar.  
A list appears.
2. From the **Admin** menu, select **O** and then click **Offset Request Type**.  
A sub-menu appears.
3. Click the **Search** option from the **Offset Request Type** sub-menu.  
The **Offset Request Type** screen appears.
4. In the **Offset Request Type List** zone, click the **Edit** (✎) icon in the **Edit** column corresponding to the offset request type whose details you want to edit.

The **Offset Request Type** screen appears. It contains the following sections:

- **Main** - Used to specify basic details about the offset request type.
- **Characteristics** - Used to define characteristics for the offset request type.

The **Main** section contains the following fields:

Field Name	Field Description	Mandatory (Yes or No)
Offset Request Type	Displays the offset request type.	Not applicable
Business Object	Indicates the business object which is used while defining the offset request type.	Not applicable
Description	Used to specify the description for the offset request type.	Yes
Offset Request Business Object	Used to indicate the business object using which you want to create the respective offset request.	Yes
Detailed Description	Used to specify additional information about the offset request type.	No
Status	Used to indicate the status of the offset request type. The valid values are: <ul style="list-style-type: none"> <li>• Active</li> <li>• Inactive</li> </ul> <div style="border: 1px solid black; padding: 5px; margin-top: 10px;"> <p><b>Note:</b> You cannot change the status of an offset request type to <b>Inactive</b> when the corresponding offset request is in a status other than <b>Processed</b>, <b>Rejected</b>, or <b>Unapplied Offset</b>.</p> </div>	Yes

Field Name	Field Description	Mandatory (Yes or No)
Adjustment Type	<p>Used to indicate the adjustment type using which transfer or offset adjustments should be created. By default, the specified adjustment type appears when you create an offset request. You can then change the adjustment type, if required, while editing an offset request.</p> <div data-bbox="591 420 1198 800" style="border: 1px solid black; padding: 5px;"> <p><b>Note:</b></p> <p>The <b>Search</b>  icon appears corresponding to the <b>Adjustment Type</b> field. On clicking the <b>Search</b> icon, the <b>Adjustment Type Search</b> window appears.</p> <p>On specifying the adjustment type, the description of the adjustment type appears corresponding to the <b>Adjustment Type</b> field.</p> <p>You can only specify an adjustment type where the <b>A/P Request Type Code</b> field is not set to <b>REFUND</b>.</p> </div>	Yes
Default Offset Amount Algorithm	<p>Used to attach an algorithm using which you want to calculate default offset amount while adding a bill in an offset request.</p> <div data-bbox="591 940 1198 1346" style="border: 1px solid black; padding: 5px;"> <p><b>Note:</b></p> <p>The <b>Search</b>  icon appears corresponding to the <b>Default Offset Amount Algorithm</b> field. On clicking the <b>Search</b> icon, the <b>Algorithm Search</b> window appears.</p> <p>On specifying the algorithm, the description of the algorithm appears corresponding to the <b>Default Offset Amount Algorithm</b> field.</p> <p>You must specify an algorithm which is created using the <b>C1-OFST-AMT</b> algorithm type in the <b>Default Offset Amount Algorithm</b> field.</p> </div>	Yes

Field Name	Field Description	Mandatory (Yes or No)
Defer Processing FT Count	<p>Used to indicate whether an offset request must be processed in the deferred mode or in real time (i.e. immediately). If the number of financial transactions created for the bills which are selected in the offset request exceeds the defer processing count, the system will process the offset request in the deferred mode. However, if the number of financial transactions created for the bills which are selected in the offset request does not exceed the defer processing count, the system will process the offset request in real time (i.e. immediately).</p> <div data-bbox="591 575 1198 1010" style="border: 1px solid black; padding: 5px;"> <p><b>Note:</b></p> <p>You cannot specify a negative value in this field.</p> <p>Deferred mode means in the background when the <b>Offset Request Periodic Monitor (C1-OFSRQ)</b> batch is invoked. You can configure the <b>Offset Request Periodic Monitor (C1-OFSRQ)</b> batch such that it is executed at regular intervals. For more information about the <b>Offset Request Periodic Monitor (C1-OFSRQ)</b> batch, refer to <i>Oracle Revenue Management and Billing Batch Guide</i>.</p> <p>If you set the defer processing count to zero (0), the system resets the default value to 50.</p> </div>	No
Approval Required	Used to indicate whether approval is required while offsetting bills through an offset request.	No
Approval To Do Type	<p>Used to indicate that To Do entry of the specified To Do type must be created when you submit an offset request for approval.</p> <div data-bbox="591 1230 1198 1724" style="border: 1px solid black; padding: 5px;"> <p><b>Note:</b></p> <p>The <b>Search</b>  icon appears corresponding to the <b>Approval To Do Type</b> field. On clicking the <b>Search</b> icon, the <b>To Do Type Search</b> window appears.</p> <p>On specifying the To Do type, the description of the To Do type appears corresponding to the <b>Approval To Do Type</b> field.</p> <p>This field appears only when the <b>Approval Required</b> option is selected.</p> <p>The <b>C1-OFSRQ</b> To Do type is shipped with the product. You can use the <b>C1-OFSRQ</b> To Do type or a custom To Do type, if required.</p> </div>	<p>Yes (Conditional)</p> <div data-bbox="1219 1167 1463 1314" style="border: 1px solid black; padding: 5px;"> <p><b>Note:</b> This field is required when the <b>Approval Required</b> option is selected.</p> </div>



Field Name	Field Description	Mandatory (Yes or No)
Approval To Do Role	<p>Used to indicate that users with the specified To Do role can only approve an offset request submitted for approval.</p> <p><b>Note:</b> The list includes only those To Do roles which are associated with the approval To Do type. This field appears only when the <b>Approval Required</b> option is selected.</p>	<p>Yes (Conditional)</p> <p><b>Note:</b> This field is required when the <b>Approval Required</b> option is selected.</p>
Submitter To Do Type	<p>At present, the submitter To Do type is not used to create To Do entry when the approver rejects an offset request. It is only used to fetch the roles associated with the submitter To Do type.</p> <p><b>Note:</b> The <b>Search</b>  icon appears corresponding to the <b>Submitter To Do Type</b> field. On clicking the <b>Search</b> icon, the <b>To Do Type Search</b> window appears. On specifying the To Do type, the description of the To Do type appears corresponding to the <b>Submitter To Do Type</b> field. The <b>C1-OFSSB</b> To Do type is shipped with the product. You can use the <b>C1-OFSSB</b> To Do type or a custom To Do type, if required.</p>	<p>Yes (Conditional)</p> <p><b>Note:</b> This field is required when the <b>Approval Required</b> option is selected.</p>
Submitter To Do Role	<p>Used to indicate that users with the specified To Do role cannot approve an offset request submitted for approval.</p> <p><b>Note:</b> The list includes only those To Do roles which are associated with the submitter To Do type.</p>	<p>Yes (Conditional)</p> <p><b>Note:</b> This field is required when the <b>Approval Required</b> option is selected.</p>
Bill Search Period	<p>Used to specify the maximum search period (in days) that you want to allow while searching bills in an offset request.</p> <p><b>Note:</b> If you do not specify any value, by default, it is set to <b>30</b>.</p>	<p>No</p>

Field Name	Field Description	Mandatory (Yes or No)
Transfer Adjustment	Used to indicate whether transfer adjustments should be created while offsetting bills through an offset request.  <b>Note:</b> This impacts the system performance when the match type entity is set to <b>BSEG</b> and volume of bill segments in the selected bills is high. Alternatively, the system enables you to create offset adjustments while offsetting bills through an offset request whenever the volume of bill segments in the selected bills is high. To create the offset adjustments while offsetting bills through an offset request, you need to ensure that the <b>Transfer Adjustment</b> option is not selected in the respective offset request type.	No

**Tip:** Alternatively, you can access this screen by clicking the **Edit** button in the **Offset Request Type** zone.

- Modify the required details in the **Main** section.
- Define, edit, or remove characteristics from the offset request type, if required.
- Click **Save**.

The changes made to the offset request type are saved.

#### Related Topics

For more information on...	See...
<b>Offset Request Type</b> screen	<a href="#">Offset Request Type</a> on page 1260
<b>Offset Request Type List</b> zone	<a href="#">Offset Request Type List</a> on page 1260
<b>Offset Request Type</b> zone	<a href="#">Offset Request Type</a> on page 1261
How to define a characteristic for an offset request type	<a href="#">Defining a Characteristic for an Offset Request Type</a> on page 1268
<b>C1-OFST-AMT</b> algorithm	<a href="#">C1-OFST-AMT</a> on page 1259

## Deleting an Offset Request Type

### Procedure

To delete an offset request type:

- Click the **Admin** link in the **Application** toolbar.  
A list appears.
- From the **Admin** menu, select **O** and then click **Offset Request Type**.  
A sub-menu appears.
- Click the **Search** option from the **Offset Request Type** sub-menu.  
The **Offset Request Type** screen appears.
- In the **Offset Request Type List** zone, click the **Delete** (🗑️) icon in the **Delete** column corresponding to the offset request type that you want to delete.  
A message appears confirming whether you want to delete the offset request type.

**Note:** You can delete an offset request type only when an offset request is not created using the offset request type.

**Tip:** Alternatively, you can delete an offset request type by clicking the **Delete** button in the **Offset Request Type** zone.

5. Click **OK**.

The offset request type is deleted.

### **Related Topics**

<b>For more information on...</b>	<b>See...</b>
<b>Offset Request Type</b> screen	<i>Offset Request Type</i> on page 1260
<b>Offset Request Type List</b> zone	<i>Offset Request Type List</i> on page 1260
<b>Offset Request Type</b> zone	<i>Offset Request Type</i> on page 1261

## **Copying an Offset Request Type**

Instead of creating an offset request type from scratch, you can create a new offset request type using an existing offset request type. This is possible through copying an offset request type. On copying an offset request type, the details including the characteristics are copied to the new offset request type. You can then edit the details, if required.

### **Prerequisites**

To copy an offset request type, you should have:

- Offset request type (whose copy you want to create) defined in the application
- Offset request business objects defined in the application
- Adjustment types defined in the application (where the **A/P Request Type Code** field is not set to **REFUND**)
- Default offset amount algorithm defined using the **C1-OFST-AMT** algorithm type
- Required To Do role assigned to the **C1-OFSRQ** and **C1-OFSSB** To Do types in the application
- Required match type entity specified in the **Match Type Entity (Valid Values: BILL, BSEG, SA)** parameter of the **C1-OFST-DIST** algorithm

### **Procedure**

To copy an offset request type:

1. Click the **Admin** link in the **Application** toolbar.  
A list appears.
2. From the **Admin** menu, select **O** and then click **Offset Request Type**.  
A sub-menu appears.
3. Click the **Search** option from the **Offset Request Type** sub-menu.  
The **Offset Request Type** screen appears.
4. In the **Offset Request Type List** zone, click the **Duplicate** () icon in the **Duplicate** column corresponding to the offset request type whose copy you want to create.



The **Offset Request Type** screen appears. It contains the following sections:

- **Main** - Used to specify basic details about the offset request type.
- **Characteristics** - Used to define characteristics for the offset request type.

The **Main** section contains the following fields:

Field Name	Field Description	Mandatory (Yes or No)
Offset Request Type	Used to specify the offset request type.	Yes
Business Object	Indicates the business object which is used while defining the offset request type.	Not applicable
Description	Used to specify the description for the offset request type.	Yes
Offset Request Business Object	Used to indicate the business object using which you want to create the respective offset request.	Yes
Detailed Description	Used to specify additional information about the offset request type.	No
Status	<p>Used to indicate the status of the offset request type. The valid values are:</p> <ul style="list-style-type: none"> <li>• Active</li> <li>• Inactive</li> </ul> <div style="border: 1px solid black; padding: 5px; margin-top: 10px;"> <p><b>Note:</b> You cannot change the status of an offset request type to <b>Inactive</b> when the corresponding offset request is in a status other than <b>Processed, Rejected, or Unapplied Offset</b>.</p> </div>	Yes
Adjustment Type	<p>Used to indicate the adjustment type using which transfer or offset adjustments should be created. By default, the specified adjustment type appears when you create an offset request. You can then change the adjustment type, if required, while editing an offset request.</p> <div style="border: 1px solid black; padding: 5px; margin-top: 10px;"> <p><b>Note:</b></p> <p>The <b>Search</b>  icon appears corresponding to the <b>Adjustment Type</b> field. On clicking the <b>Search</b> icon, the <b>Adjustment Type Search</b> window appears.</p> <p>On specifying the adjustment type, the description of the adjustment type appears corresponding to the <b>Adjustment Type</b> field.</p> <p>You can only specify an adjustment type where the <b>A/P Request Type Code</b> field is not set to <b>REFUND</b>.</p> </div>	Yes

Field Name	Field Description	Mandatory (Yes or No)
Default Offset Amount Algorithm	<p>Used to attach an algorithm using which you want to calculate default offset amount while adding a bill in an offset request.</p> <div data-bbox="591 352 1198 764" style="border: 1px solid black; padding: 5px;"> <p><b>Note:</b></p> <p>The <b>Search</b>  icon appears corresponding to the <b>Default Offset Amount Algorithm</b> field. On clicking the <b>Search</b> icon, the <b>Algorithm Search</b> window appears.</p> <p>On specifying the algorithm, the description of the algorithm appears corresponding to the <b>Default Offset Amount Algorithm</b> field.</p> <p>You must specify an algorithm which is created using the <b>C1-OFST-AMT</b> algorithm type in the <b>Default Offset Amount Algorithm</b> field.</p> </div>	Yes
Defer Processing FT Count	<p>Used to indicate whether an offset request must be processed in the deferred mode or in real time (i.e. immediately). If the number of financial transactions created for the bills which are selected in the offset request exceeds the defer processing count, the system will process the offset request in the deferred mode. However, if the number of financial transactions created for the bills which are selected in the offset request does not exceed the defer processing count, the system will process the offset request in real time (i.e. immediately).</p> <div data-bbox="591 1125 1198 1558" style="border: 1px solid black; padding: 5px;"> <p><b>Note:</b></p> <p>You cannot specify a negative value in this field.</p> <p>Deferred mode means in the background when the <b>Offset Request Periodic Monitor (C1-OFSRQ)</b> batch is invoked. You can configure the <b>Offset Request Periodic Monitor (C1-OFSRQ)</b> batch such that it is executed at regular intervals. For more information about the <b>Offset Request Periodic Monitor (C1-OFSRQ)</b> batch, refer to <i>Oracle Revenue Management and Billing Batch Guide</i>.</p> <p>If you set the defer processing count to zero (0), the system resets the default value to 50.</p> </div>	No
Approval Required	Used to indicate whether approval is required while offsetting bills through an offset request.	No

Field Name	Field Description	Mandatory (Yes or No)
Approval To Do Type	<p>Used to indicate that To Do entry of the specified To Do type must be created when you submit an offset request for approval.</p> <p><b>Note:</b></p> <p>The <b>Search</b>  icon appears corresponding to the <b>Approval To Do Type</b> field. On clicking the <b>Search</b> icon, the <b>To Do Type Search</b> window appears.</p> <p>On specifying the To Do type, the description of the To Do type appears corresponding to the <b>Approval To Do Type</b> field.</p> <p>This field appears only when the <b>Approval Required</b> option is selected.</p> <p>The <b>C1-OFSRQ</b> To Do type is shipped with the product. You can use the <b>C1-OFSRQ</b> To Do type or a custom To Do type, if required.</p>	<p>Yes (Conditional)</p> <p><b>Note:</b> This field is required when the <b>Approval Required</b> option is selected.</p>
Approval To Do Role	<p>Used to indicate that users with the specified To Do role can only approve an offset request submitted for approval.</p> <p><b>Note:</b></p> <p>The list includes only those To Do roles which are associated with the approval To Do type.</p> <p>This field appears only when the <b>Approval Required</b> option is selected.</p>	<p>Yes (Conditional)</p> <p><b>Note:</b> This field is required when the <b>Approval Required</b> option is selected.</p>
Submitter To Do Type	<p>At present, the submitter To Do type is not used to create To Do entry when the approver rejects an offset request. It is only used to fetch the roles associated with the submitter To Do type.</p> <p><b>Note:</b></p> <p>The <b>Search</b>  icon appears corresponding to the <b>Submitter To Do Type</b> field. On clicking the <b>Search</b> icon, the <b>To Do Type Search</b> window appears.</p> <p>On specifying the To Do type, the description of the To Do type appears corresponding to the <b>Submitter To Do Type</b> field.</p> <p>The <b>C1-OFSSB</b> To Do type is shipped with the product. You can use the <b>C1-OFSSB</b> To Do type or a custom To Do type, if required.</p>	<p>Yes (Conditional)</p> <p><b>Note:</b> This field is required when the <b>Approval Required</b> option is selected.</p>

Field Name	Field Description	Mandatory (Yes or No)
Submitter To Do Role	Used to indicate that users with the specified To Do role cannot approve an offset request submitted for approval.  <b>Note:</b> The list includes only those To Do roles which are associated with the submitter To Do type.	Yes (Conditional)  <b>Note:</b> This field is required when the <b>Approval Required</b> option is selected.
Bill Search Period	Used to specify the maximum search period (in days) that you want to allow while searching bills in an offset request.  <b>Note:</b> If you do not specify any value, by default, it is set to <b>30</b> .	No
Transfer Adjustment	Used to indicate whether transfer adjustments should be created while offsetting bills through an offset request.  <b>Note:</b> This impacts the system performance when the match type entity is set to <b>BSEG</b> and volume of bill segments in the selected bills is high. Alternatively, the system enables you to create offset adjustments while offsetting bills through an offset request whenever the volume of bill segments in the selected bills is high. To create the offset adjustments while offsetting bills through an offset request, you need to ensure that the <b>Transfer Adjustment</b> option is not selected in the respective offset request type.	No

**Tip:** Alternatively, you can copy an offset request type by clicking the **Duplicate** button in the **Offset Request Type** zone.

5. Enter the required details in the **Main** section.
6. Define, edit, or remove characteristics from the offset request type, if required.
7. Click **Save**.

The new offset request type is defined.

#### **Related Topics**

For more information on...	See...
Offset Request Type screen	<a href="#">Offset Request Type</a> on page 1260
Offset Request Type List zone	<a href="#">Offset Request Type List</a> on page 1260
Offset Request Type zone	<a href="#">Offset Request Type</a> on page 1261
How to define a characteristic for an offset request type	<a href="#">Defining a Characteristic for an Offset Request Type</a> on page 1268
C1-OFST-AMT algorithm	<a href="#">C1-OFST-AMT</a> on page 1259

## Viewing the Offset Request Type Details

### Procedure

To view the details of an offset request type:

1. Click the **Admin** link in the **Application** toolbar.  
A list appears.
2. From the **Admin** menu, select **O** and then click **Offset Request Type**.  
A sub-menu appears.
3. Click the **Search** option from the **Offset Request Type** sub-menu.  
The **Offset Request Type** screen appears.
4. In the **Offset Request Type List** zone, click the **Broadcast**  icon corresponding to the offset request type whose details you want to view.  
The **Offset Request Type** zone appears.
5. View the details of the offset request type in the **Offset Request Type** zone.

### Related Topics

For more information on...	See...
Offset Request Type screen	<a href="#">Offset Request Type</a> on page 1260
Offset Request Type List zone	<a href="#">Offset Request Type List</a> on page 1260
Offset Request Type zone	<a href="#">Offset Request Type</a> on page 1261

## Offset Request (Used for Searching)

The **Offset Request** screen allows you to search for an offset request using various search criteria. It also allows you to define an offset request. It contains the following zone:

- [Search Offset Request](#) on page 1280

Through this screen, you can navigate to the following screen:

- [Offset Request \(Used for Viewing\)](#) on page 1287

## Search Offset Request



The **Search Offset Request** zone allows you to search for an offset request using various search criteria. It contains the following two sections:

- **Search Criteria** - The **Search Criteria** section contains the following fields:

Field Name	Field Description	Mandatory (Yes or No)
Search By	Used to indicate whether you want to search for an offset request using the offset request or bill details. The valid values are: <ul style="list-style-type: none"> <li>• Request Details</li> <li>• Bill Details</li> </ul> <div style="border: 1px solid black; padding: 2px; margin-top: 5px;"><b>Note:</b> By default, the <b>Request Details</b> option is selected.</div>	Yes



Field Name	Field Description	Mandatory (Yes or No)
Offset Request ID	Used to search a particular offset request.  <b>Note:</b> This field appears when the <b>Request Details</b> option is selected from the <b>Search By</b> list.	No
Created From	Used to search offset requests which are created from a particular date onwards.  <b>Note:</b> This field appears when the <b>Request Details</b> option is selected from the <b>Search By</b> list.	No
User ID	Used to search offset requests which are created by a particular user.  <b>Note:</b> This field appears when the <b>Request Details</b> option is selected from the <b>Search By</b> list.	No
Created To	Used to search offset requests which are created till a particular date.  <b>Note:</b> This field appears when the <b>Request Details</b> option is selected from the <b>Search By</b> list.	No
Status	Used to search offset requests with a particular status. The valid values are: <ul style="list-style-type: none"> <li>• Approval In Progress</li> <li>• Defer Unapplied</li> <li>• Deferred Processing</li> <li>• Draft</li> <li>• Processed</li> <li>• Rejected</li> <li>• Unapplied Offset</li> </ul> <b>Note:</b> This field appears when the <b>Request Details</b> option is selected from the <b>Search By</b> list.	No
Person ID	Used to search offset requests which include bills of a particular person.  <b>Note:</b> This field appears when the <b>Request Details</b> option is selected from the <b>Search By</b> list.  The <b>Search</b>  icon appears corresponding to the <b>Person ID</b> field. On clicking the <b>Search</b> icon, the <b>Person Search</b> window appears.	No

Field Name	Field Description	Mandatory (Yes or No)
Offset Request Type	Used to search offset requests which are created using a particular offset request type.  <b>Note:</b> This field appears when the <b>Request Details</b> option is selected from the <b>Search By</b> list.	No
Account ID	Used to search offset requests which include bills of a particular account.  <b>Note:</b> This field appears when the <b>Request Details</b> option is selected from the <b>Search By</b> list.  The <b>Search</b>  icon appears corresponding to the <b>Account ID</b> field. On clicking the <b>Search</b> icon, the <b>Account Search</b> window appears.	No
Bill ID	Used to search offset requests which include a particular bill.  <b>Note:</b> This field appears when the <b>Bill Details</b> option is selected from the <b>Search By</b> list.  The <b>Search</b>  icon appears corresponding to the <b>Bill ID</b> field. On clicking the <b>Search</b> icon, the <b>Bill Search</b> window appears.	No
Bill Date From	Used to search offset requests which include bills created from a particular date onwards.  <b>Note:</b> This field appears when the <b>Bill Details</b> option is selected from the <b>Search By</b> list.	No
Alternate Bill ID	Used to search offset requests which include a particular bill.  <b>Note:</b> This field appears when the <b>Bill Details</b> option is selected from the <b>Search By</b> list.	No
Bill Date To	Used to search offset requests which include bills created till a particular date.  <b>Note:</b> This field appears when the <b>Bill Details</b> option is selected from the <b>Search By</b> list.	No
<b>Note:</b> You must specify at least one search criterion while searching for an offset request.		

- **Search Results** - On clicking the **Search** button, the search results appear based on the specified search criteria. The **Search Results** section contains the following columns:

Column Name	Column Description
Creation Date Time	Displays the date and time when the offset request is created.
Offset Request Information	Displays information about the offset request. <b>Note:</b> It has a link. On clicking the link, the <b>Offset Request</b> screen appears where you can view the details of the respective offset request.
Offset Amount	Displays the total amount which is offset through the offset request.
Status	Indicates the status of the offset request. The valid values are: <ul style="list-style-type: none"> <li>• Approval In Progress</li> <li>• Defer Unapplied</li> <li>• Deferred Processing</li> <li>• Draft</li> <li>• Processed</li> <li>• Rejected</li> <li>• Unapplied Offset</li> </ul>
Created By	Indicates the user who has created the offset request.
Creation Mode	Indicates whether the offset request is created manually or automatically. The valid values are: <ul style="list-style-type: none"> <li>• Automatic</li> <li>• Manual</li> </ul>
Primary Bill	Indicates the bill for which the offset request is created. In addition, this column has a context menu which helps in navigating to other screens in the application. <b>Note:</b> It has a link. On clicking the link, the <b>Bill</b> screen appears where you can view the details of the respective bill.

**Note:** Pagination is used to display limited number of records in the **Search Results** section. You can use the navigation links, such as **Previous** and **Next** to navigate between pages.

### **Related Topics**

For more information on...	See...
How to search for an offset request	<a href="#">Searching for an Offset Request</a> on page 1283
How to view the details of an offset request	<a href="#">Viewing the Offset Request Details</a> on page 1286
How to create an offset request	<a href="#">Creating an Offset Request</a> on page 1284

## **Searching for an Offset Request**

### **Prerequisites**

To search for an offset request, you should have:

- Offset request types defined in the application

### **Procedure**

To search for an offset request:

1. Click the **Menu** link in the **Application** toolbar.  
A list appears.
2. From the **Main** menu, select **Financial** and then click **Offset Request**.  
A sub-menu appears.
3. Click the **Search** option from the **Offset Request** sub-menu.  
The **Offset Request** screen appears.
4. Enter the search criteria in the **Search Offset Request** zone.

**Note:** ORMB search engine supports wildcard search, where you can substitute the percentage (%) symbol as a stand in for any word or letter in a search criteria. You can use the ‘%’ wildcard character in all input fields except the date and ID fields. The ‘%’ wildcard character is suffixed automatically at the end of the partial search criteria. Therefore, you may or may not specify the wildcard character at the end of the partial search criteria. However, you have to prefix the wildcard character manually wherever required.

5. Click **Search**.

A list of offset requests that meet the search criteria appears in the **Search Results** section.

### Related Topics

For more information on...	See...
<b>Offset Request</b> screen	<a href="#">Offset Request (Used for Searching)</a> on page 1280
<b>Search Offset Request</b> zone	<a href="#">Search Offset Request</a> on page 1280

## Creating an Offset Request

### Prerequisites

To create an offset request, you should have:

- Offset request types defined in the application
- Bills created in the application

### Procedure

To create an offset request:

1. Do either of the following:

If you want to...	Then...
Create a single offset request from the <b>Account Receivable Central</b> screen	<ol style="list-style-type: none"> <li>1. Click the <b>Menu</b> link in the <b>Application</b> toolbar. A list appears.</li> <li>2. From the <b>Main</b> menu, select <b>Financial</b> and then click <b>Account Receivable Central</b>. The <b>Account Receivable Central</b> screen appears.</li> <li>3. Search for the required bill in the <b>Search Bill</b> zone.</li> </ol>

If you want to...	Then...
	<ol style="list-style-type: none"> <li>4. In the <b>Search Results</b> section, select the check box corresponding to the bill which you want to offset through a single offset request.</li> <li>5. Click <b>Single Offset</b>.</li> </ol>
Create a mass offset request from the <b>Account Receivable Central</b> screen	<ol style="list-style-type: none"> <li>1. Click the <b>Menu</b> link in the <b>Application</b> toolbar. A list appears.</li> <li>2. From the <b>Main</b> menu, select <b>Financial</b> and then click <b>Account Receivable Central</b>. The <b>Account Receivable Central</b> screen appears.</li> <li>3. Search for the required bill in the <b>Search Bill</b> zone.</li> <li>4. In the <b>Search Results</b> section, select the check box corresponding to the bill which you want to offset through a mass offset request.</li> <li>5. Click <b>Mass Offset</b>.</li> </ol>
Create a cross currency offset request from the <b>Account Receivable Central</b> screen	<ol style="list-style-type: none"> <li>1. Click the <b>Menu</b> link in the <b>Application</b> toolbar. A list appears.</li> <li>2. From the <b>Main</b> menu, select <b>Financial</b> and then click <b>Account Receivable Central</b>. The <b>Account Receivable Central</b> screen appears.</li> <li>3. Search for the required bill in the <b>Search Bill</b> zone.</li> <li>4. In the <b>Search Results</b> section, select the check box corresponding to the bill which you want to offset through a cross currency offset request.</li> <li>5. Click <b>Cross Currency Offset</b>.</li> </ol>
Create a single, mass, or cross currency offset request from the <b>Offset Request</b> screen	<ol style="list-style-type: none"> <li>1. Click the <b>Menu</b> link in the <b>Application</b> toolbar. A list appears.</li> <li>2. From the <b>Main</b> menu, select <b>Financial</b> and then click <b>Offset Request</b>. A sub-menu appears.</li> <li>3. Click the <b>Add</b> option from the <b>Offset Request</b> sub-menu.</li> </ol>

The **Add Offset Request** screen appears. It contains the following fields:

Field Name	Field Description	Mandatory (Yes or No)
Offset Request Type	Used to indicate the offset request type using which you want to create the offset request.	Yes

Field Name	Field Description	Mandatory (Yes or No)
Bill	Used to indicate the bill which you want to offset through the offset request.  <div style="border: 1px solid black; padding: 5px;"> <p><b>Note:</b></p> <p>The <b>Search</b>  icon appears corresponding to the <b>Bill</b> field. On clicking the <b>Search</b> icon, the <b>Bill Search</b> window appears. On specifying the bill, the information about the bill appears corresponding to the <b>Bill</b> field.</p> </div>	Yes

**Tip:** Alternatively, you can access this screen by clicking the **Add** button in the **Page Title** area of the **Offset Request** screen.

- Enter the required details in the **Add Offset Request** screen.
- Click **Save**.

The offset request is created in the **Draft** status. The **Offset Request** screen appears where you can view the details of the offset request. By default, the adjustment type specified in the respective offset request type is used while creating the offset request. You can then change the adjustment type, if required.

- Add debit and/or credit bills in the offset request.
- Define characteristics for the offset request, if required.

### Related Topics

For more information on...	See...
Single Offset Request	<a href="#">Single Offset</a> on page 1245
Mass Offset Request	<a href="#">Mass Offset</a> on page 1246
Cross Currency Offset Request	<a href="#">Cross Currency Offset</a> on page 1249
<b>Offset Request</b> screen	<a href="#">Offset Request (Used for Searching)</a> on page 1280
How to add a debit or credit bill to an offset request	<a href="#">Adding a Debit or Credit Bill to an Offset Request</a> on page 1298
How to define a characteristic for an offset request	<a href="#">Defining a Characteristic for an Offset Request</a> on page 1301

## Viewing the Offset Request Details

### Procedure

To view the details of an offset request:

- Search for the offset request in the **Offset Request** screen.
- In the **Search Results** section, click the link in the **Offset Request Information** column corresponding to the offset request whose details you want to view.

The **Offset Request** screen appears.

- Ensure that the **Main** tab is selected.
- View the details of the offset request in the **Offset Request** zone.

### Related Topics

For more information on...	See...
How to search for an offset request	<a href="#">Searching for an Offset Request</a> on page 1283
<b>Offset Request</b> screen	<a href="#">Offset Request (Used for Viewing)</a> on page 1287
<b>Offset Request</b> zone	<a href="#">Offset Request</a> on page 1287

## Offset Request (Used for Viewing)

The **Offset Request** screen allows you to:

- View the details of the offset request
- View the debit and credit bills which are added to the offset request
- View the offset or transfer adjustments which are created through the offset request
- Add a debit or credit bill to the offset request
- Edit the details of the offset request
- Define, edit, or remove the characteristics from the offset request
- Edit the offset amount for each debit and credit bill
- Remove a debit or credit bill from the offset request
- Delete the offset request
- Submit the offset request for approval
- Approve or reject the offset request
- Unapply (i.e. cancel) the offset request
- View the log of the offset request
- Add a log entry for the offset request

It consists of the following tabs:

- [Offset Request - Main](#) on page 1287
- [Offset Request - Log](#) on page 1296

### Offset Request - Main

The **Main** tab displays information about the offset request. It contains the following zones:

- [Offset Request](#) on page 1287
- [Selected Bills](#) on page 1290
- [Search Bill](#) on page 1291
- [Offset Request Adjustments](#) on page 1296

### Offset Request

The **Offset Request** zone displays the details of the offset request. It contains the following sections:

- **Main** - Displays basic information about the offset request. It contains the following fields:

Field Name	Field Description
Offset Request Information	Displays information about the offset request.

Field Name	Field Description
Offset Request Type	<p>Indicates the offset request type using which the offset request is created.</p> <p><b>Note:</b> It has a link. On clicking the link, the <b>Offset Request Type</b> screen appears where you can view the details of the respective offset request type.</p>
Status	<p>Indicates the status of the offset request. The valid values are:</p> <ul style="list-style-type: none"> <li>• Approval In Progress</li> <li>• Defer Unapplied</li> <li>• Deferred Processing</li> <li>• Draft</li> <li>• Rejected</li> <li>• Processed</li> <li>• Unapplied Offset</li> </ul>
Status Reason	<p>Indicates the reason why the offset request is rejected or unapplied (i.e. canceled).</p> <p><b>Note:</b> It has a link. On clicking the link, the <b>Status Reason</b> screen appears where you can view the details of the respective status reason. This field appears only when the offset request is in the <b>Rejected, Defer Unapplied, or Unapplied Offset</b> status.</p>
Adjustment Type	<p>Indicates the adjustment type using which the offset or transfer adjustments should be created through the offset request.</p> <p><b>Note:</b> It has a link. On clicking the link, the <b>Adjustment Type</b> screen appears where you can view the details of the respective adjustment type.</p>
Offset Amount	Displays the total amount which is offset through the offset request.
Comments	<p>Displays additional details specified while rejecting or unapplying (i.e. canceling) the offset request.</p> <p><b>Note:</b> This field appears only when the offset request is in the <b>Rejected, Defer Unapplied, or Unapplied Offset</b> status.</p>

- **Characteristics** - Lists the characteristics defined for the offset request. It contains the following columns:

Column Name	Column Description
Effective Date	Displays the date from when the characteristic is effective for the offset request.
Characteristic Type	Indicates the characteristic type.
Characteristic Value	Displays the value of the characteristic type.

- **Record Actions** - This section contains the following buttons:



Button Name	Button Description
Edit	Used to edit the details of the offset request. <b>Note:</b> The <b>Edit</b> button appears only when the offset request is in the <b>Draft</b> status.
Delete	Used to delete the offset request. <b>Note:</b> The <b>Delete</b> button appears only when the offset request is in the <b>Draft</b> status.
Submit	Used to submit the offset request. <b>Note:</b> The <b>Submit</b> button appears only when the offset request is in the <b>Draft</b> status.
Approve	Used to approve the offset request. <b>Note:</b> The <b>Approve</b> button appears only when: <ul style="list-style-type: none"> <li>The offset request is in the <b>Approval In Progress</b> status.</li> <li>A user with the approval To Do role is reviewing the offset request.</li> </ul>
Reject	Used to reject the offset request. <b>Note:</b> The <b>Reject</b> button appears only when: <ul style="list-style-type: none"> <li>The offset request is in the <b>Approval In Progress</b> status.</li> <li>A user with the approval To Do role is reviewing the offset request.</li> </ul>
Unapply	Used to unapply (i.e. cancel) the offset request. <b>Note:</b> The <b>Unapply</b> button appears only when the offset request is in the <b>Processed</b> status.

- **Record Information** - This section contains the following fields:

Field Name	Field Description
Business Object	Indicates the business object using which the offset request is created. In addition, a context menu appears corresponding to this field which helps in navigating to other screens in the application. <b>Note:</b> It has a link. On clicking the link, the <b>Business Object</b> screen appears where you can view the details of the respective business object.
Status Date/Time	Displays the date and time when the offset request status is updated
Create Date/Time	Displays the date and time when the offset request is created.

### Related Topics

For more information on...	See...
How to edit an offset request	<a href="#">Editing an Offset Request</a> on page 1299
How to delete an offset request	<a href="#">Deleting an Offset Request</a> on page 1303
How to submit an offset request	<a href="#">Submitting an Offset Request</a> on page 1304

For more information on...	See...
How to approve an offset request	<a href="#">Approving an Offset Request</a> on page 1306
How to reject an offset request	<a href="#">Rejecting an Offset Request</a> on page 1308
How to unapply (i.e. cancel) an offset request	<a href="#">Unapplying an Offset Request</a> on page 1310

### Selected Bills

The **Selected Bills** zone lists the debit and credit bills which are added to the offset request. It contains the following columns:

Column Name	Column Description
Bill Information	Indicates the debit or credit bill which is added to the offset request. In addition, this column has a context menu which helps in navigating to other screens in the application.  <b>Note:</b> It has a link. On clicking the link, the <b>Bill</b> screen appears where you can view the details of the respective bill.
Bill Date	Displays the date when the debit or credit bill is created.
Outstanding Amount	Displays the outstanding amount (i.e. unpaid amount) of the debit or credit bill.
Hold Amount	Displays the amount of the debit or credit bill which is kept on hold through an hold request.
Offset Amount	Displays the amount which you want to offset from the debit or credit bill.
Remaining Bill Balance	Displays the remaining outstanding amount of the debit or credit bill (i.e. Outstanding Amount - Hold Amount - Offset Amount).  <b>Note:</b> This column does not appear when the offset request is in the <b>Processed</b> or <b>Unapplied Offset</b> status.
Updated Hold Amount	Displays the new hold amount (i.e. Current Hold Amount + Remaining Bill Balance) for the debit or credit bill which is derived when the remaining bill balance is less than the current hold amount.  <b>Note:</b> This column does not appear when the offset request is in the <b>Processed</b> or <b>Unapplied Offset</b> status.
Account Information	Indicates the account for which the debit or credit bill is created. In addition, this column has a context menu which helps in navigating to other screens in the application.  <b>Note:</b> It has a link. On clicking the link, the <b>Account</b> screen appears where you can view the details of the respective account.
Bill ID	Displays the bill ID.

**Note:** Pagination is used to display limited number of records in this zone. You can use the navigation links, such as **Previous** and **Next** to navigate between pages.

On clicking the **Broadcast**  icon corresponding to a bill, the **Offset Request Adjustments** zone appears where you can view the offset or transfer adjustments created for the bill through the offset request.

**Note:** The **Broadcast**  icon appears corresponding to a bill only when the offset request is in the **Processed** or **Unapplied Offset** status.

You can filter the list using various search criteria (such as, **Bill Balance**, **Bill ID**, and **Account ID**) available in the **Filter** area. By default, the **Filter** area is hidden. You can view the **Filter** area by clicking the **Filters** (  ) icon in the upper right corner of this zone.

You can change the layout of this zone. For more information on how to change the layout, see [Changing the Layout](#) on page 2882.

### **Related Topics**

<b>For more information on...</b>	<b>See...</b>
How to view the debit or credit bills added to an offset request	<a href="#">Viewing the Debit and Credit Bills Added to an Offset Request</a> on page 1297

### **Search Bill**

The bills listed in the **Search Bill** zone varies depending on the following scenarios:

<b>If...</b>	<b>Then...</b>
The single offset request is created through the <b>Account Receivable Central</b> screen and the <b>Allow Offsetting Across Persons</b> option type of the <b>C1-OFFSETREQ</b> feature configuration is set to <b>Y</b>	The <b>Search Bill</b> zone lists completed bills of all accounts of the main customer (whose bill is added as the primary bill in the offset request) and completed bills of all accounts of its effective child persons. If the primary bill is a debit bill, it lists credit bills of the main customer and its child persons. However, if the primary bill is a credit bill, it lists debit bills of the main customer and its child persons. Note that it lists only those bills which are in the same currency as that of the primary bill. For example, if the primary bill is in USD, then this zone lists all completed bills of the main customer and its child persons which are in USD.
The single offset request is created through the <b>Account Receivable Central</b> screen and the <b>Allow Offsetting Across Persons</b> option type of the <b>C1-OFFSETREQ</b> feature configuration is set to <b>N</b>	The <b>Search Bill</b> zone lists completed bills of all accounts of the main customer (whose bill is added as the primary bill in the offset request). If the primary bill is a debit bill, it lists credit bills of the main customer. However, if the primary bill is a credit bill, it lists debit bills of the main customer. Note that it lists only those bills which are in the same currency as that of the primary bill. For example, if the primary bill is in USD, then this zone lists all completed bills of the main customer which are in USD.
The mass offset request is created through the <b>Account Receivable Central</b> screen and the <b>Allow Offsetting Across Persons</b> option type of the <b>C1-OFFSETREQ</b> feature configuration is set to <b>Y</b>	The <b>Search Bill</b> zone lists completed debit and credit bills of all accounts of the main customer (whose bill is added as the primary bill in the offset request) and completed debit and credit bills of all accounts of its effective child persons. Note that it lists only those debit and credit bills which are in the same currency as that of the primary bill. For example, if the primary bill is in USD, then this zone lists all completed debit and credit bills of the main customer and its child persons which are in USD.

If...	Then...
<p>The mass offset request is created through the <b>Account Receivable Central</b> screen and the <b>Allow Offsetting Across Persons</b> option type of the <b>C1-OFFSETREQ</b> feature configuration is set to <b>N</b></p>	<p>The <b>Search Bill</b> zone lists completed debit and credit bills of all accounts of the main customer (whose bill is added as the primary bill in the offset request). Note that it lists only those debit and credit bills which are in the same currency as that of the primary bill. For example, if the primary bill is in USD, then this zone lists all completed debit and credit bills of the main customer which are in USD.</p>
<p>The cross currency offset request is created through the <b>Account Receivable Central</b> screen and the <b>Allow Offsetting Across Persons</b> option type of the <b>C1-OFFSETREQ</b> feature configuration is set to <b>Y</b></p>	<p>The <b>Search Bill</b> zone lists completed debit and credit bills of all accounts of the main customer (whose bill is added as the primary bill in the offset request) and completed debit and credit bills of all accounts of its effective child persons. Note that it lists only those debit and credit bills which are in the currency different from the primary bill. For example, if the primary bill is in USD, then this zone lists all completed debit and credit bills of the main customer and its child persons which are in the currency other than USD.</p>
<p>The cross currency offset request is created through the <b>Account Receivable Central</b> screen and the <b>Allow Offsetting Across Persons</b> option type of the <b>C1-OFFSETREQ</b> feature configuration is set to <b>N</b></p>	<p>The <b>Search Bill</b> zone lists completed debit and credit bills of all accounts of the main customer (whose bill is added as the primary bill in the offset request). Note that it lists only those debit and credit bills which are in the currency different from the primary bill. For example, if the primary bill is in USD, then this zone lists all completed debit and credit bills of the main customer which are in the currency other than USD.</p>
<p>The offset request is created through the <b>Offset Request</b> screen and the <b>Allow Offsetting Across Persons</b> option type of the <b>C1-OFFSETREQ</b> feature configuration is set to <b>Y</b></p>	<p>The <b>Search Bill</b> zone lists completed debit and credit bills of all accounts of the main customer (whose bill is added as the primary bill in the offset request) and completed debit and credit bills of all accounts of its effective child persons. Note that it lists only those debit and credit bills which are in the same currency as that of the primary bill. For example, if the primary bill is in USD, then this zone lists all completed debit and credit bills of the main customer and its child persons which are in USD.</p> <div data-bbox="854 1396 1468 1512" style="border: 1px solid black; padding: 5px;"> <p><b>Note:</b> This zone lists the debit and credit bills in the currency different from the primary bill only when the <b>Show Cross Currency Bills</b> option is selected.</p> </div>
<p>The offset request is created through the <b>Offset Request</b> screen and the <b>Allow Offsetting Across Persons</b> option type of the <b>C1-OFFSETREQ</b> feature configuration is set to <b>N</b></p>	<p>The <b>Search Bill</b> zone lists completed debit and credit bills of all accounts of the main customer (whose bill is added as the primary bill in the offset request). Note that it lists only those debit and credit bills which are in the same currency as that of the primary bill. For example, if the primary bill is in USD, then this zone lists all completed debit and credit bills of the main customer which are in USD.</p> <div data-bbox="854 1810 1468 1925" style="border: 1px solid black; padding: 5px;"> <p><b>Note:</b> This zone lists the debit and credit bills in the currency different from the primary bill only when the <b>Show Cross Currency Bills</b> option is selected.</p> </div>

It also allows you to filter the bills using various search criteria. It contains the following two sections:

- **Search Criteria** - The **Search Criteria** section contains the following fields:

Field Name	Field Description	Mandatory (Yes or No)
Search By	<p>Used to indicate whether you want to search for a completed bill using the person, account, or bill details. The valid values are:</p> <ul style="list-style-type: none"> <li>• Person Details</li> <li>• Account Details</li> <li>• Bill Details</li> </ul> <p><b>Note:</b> By default, the <b>Person Details</b> option is selected.</p>	Yes
Person ID	<p>Used to search completed bills of a particular person.</p> <p><b>Note:</b> This field appears when the <b>Person Details</b> option is selected from the <b>Search By</b> list. The <b>Search</b>  icon appears corresponding to the <b>Person ID</b> field. On clicking the <b>Search</b> icon, the <b>Person Search</b> window appears.</p>	No
Bill Date From	<p>Used to search completed bills which are created from a particular date onwards.</p> <p><b>Note:</b> By default, it is set to a date which is calculated as follows: Bill Date To - Bill Search Period (Specified in Offset Request Type)</p>	Yes
Bills on Hold	<p>Used to indicate whether you want to search completed bills which are partially kept on hold. The valid values are:</p> <ul style="list-style-type: none"> <li>• No</li> <li>• Yes</li> </ul>	No
Bill Date To	<p>Used to search completed bills which are created till a particular date.</p> <p><b>Note:</b> By default, it is set to the current date.</p>	Yes

Field Name	Field Description	Mandatory (Yes or No)								
Bill Balance	<p>Used to indicate whether you want to search completed bills with a particular balance amount. The valid values are:</p> <ul style="list-style-type: none"> <li>• Equal to Zero</li> <li>• Greater Than Zero</li> <li>• Less Than Zero</li> <li>• Not Equal to Zero</li> </ul> <p><b>Note:</b> If a single or cross currency offset request is created through the <b>Account Receivable Central</b> screen, this field is disabled, and by default, it is set to the following:</p> <table border="1"> <thead> <tr> <th>If the primary bill is a...</th> <th>Then, it is set to...</th> </tr> </thead> <tbody> <tr> <td>Credit Bill</td> <td>Greater Than Zero</td> </tr> <tr> <td>Debit Bill</td> <td>Less Than Zero</td> </tr> <tr> <td></td> <td></td> </tr> </tbody> </table>	If the primary bill is a...	Then, it is set to...	Credit Bill	Greater Than Zero	Debit Bill	Less Than Zero			No
If the primary bill is a...	Then, it is set to...									
Credit Bill	Greater Than Zero									
Debit Bill	Less Than Zero									
Show Cross Currency Bills	<p>Used to indicate whether you want to search completed bills in the currencies different from the primary bill.</p> <p><b>Note:</b> This option is disabled when a single or cross currency offset request is created through the <b>Account Receivable Central</b> screen. By default, this option is selected when a cross currency offset request is created through the <b>Account Receivable Central</b> screen.</p>	No								
Account ID	<p>Used to search completed bills which created for a particular account.</p> <p><b>Note:</b> This field appears when the <b>Account Details</b> option is selected from the <b>Search By</b> list. The <b>Search</b>  icon appears corresponding to the <b>Account ID</b> field. On clicking the <b>Search</b> icon, the <b>Account Search</b> window appears.</p>	Yes								

Field Name	Field Description	Mandatory (Yes or No)
Bill ID	Used to search a particular completed bill.  <b>Note:</b> This field appears when the <b>Bill Details</b> option is selected from the <b>Search By</b> list.  The <b>Search</b>  icon appears corresponding to the <b>Bill ID</b> field. On clicking the <b>Search</b> icon, the <b>Bill Search</b> window appears.	No

- **Search Results** - On clicking the **Search** button, the search results appear based on the specified search criteria. The **Search Results** section contains the following columns:

Column Name	Column Description
Bill Information	Display information about the completed debit or credit bill. In addition, this column has a context menu which helps in navigating to other screens in the application.  <b>Note:</b> It has a link. On clicking the link, the <b>Bill</b> screen appears where you can view the details of the respective bill.
Bill Date	Displays the date when the debit or credit bill is created.
Due Date	Displays the date when the debit or credit bill is due for payment.
Outstanding Amount	Displays the outstanding amount (i.e. unpaid amount) of the debit or credit bill.
Hold Amount	Displays the amount of the debit or credit bill which is kept on hold through an hold request.
Outstanding Amount (Offset Currency)	Displays the outstanding amount (i.e. unpaid amount) of the debit or credit bill in the currency in which the bill amount would be offset.  <b>Note:</b> This column appears only when the offset request is a cross-currency offset request.
Account Information	Indicates the account for which the debit or credit bill is created. In addition, this column has a context menu which helps in navigating to other screens in the application.  <b>Note:</b> It has a link. On clicking the link, the <b>Account</b> screen appears where you can view the details of the respective account.

**Note:** Pagination is used to display limited number of records in the **Search Results** section. You can use the navigation links, such as **Previous** and **Next** to navigate between pages.

In addition, this section contains the following button:

Button Name	Button Description
Add	Used to add a bill to the offset request.

A check box appears corresponding to each bill. On selecting the check box, you can add the bill to the offset request. You can also select multiple bills at the same time. In addition, you can select the check box corresponding to the column header. This allows you to add all bills listed in the respective page to the offset request.

**Related Topics**

For more information on...	See...
How to add a debit or credit bill to an offset request	<a href="#">Adding a Debit or Credit Bill to an Offset Request</a> on page 1298
How to setup the <b>C1-OFFSETREQ</b> feature configuration	<a href="#">Setting the C1-OFFSETREQ Feature Configuration</a> on page 2917

**Offset Request Adjustments**

The **Offset Request Adjustments** zone lists the offset or transfer adjustments which are created for the bill through the offset request. It appears only when the offset request is in the **Processed** status. It contains the following columns:

Column Name	Column Description
Adjustment Information	Displays information about the offset or transfer adjustment.  <b>Note:</b> It has a link. On clicking the link, the <b>Adjustment</b> screen appears where you can view the details of the respective adjustment.
From Bill ID	Indicates the bill from where the amount is offset.
To Bill ID	Indicates the bill against which the amount is offset.
Current Amount	Displays the adjustment amount.

**Related Topics**

For more information on...	See...
How to view the offset or transfer adjustments created through an offset request	<a href="#">Viewing the Adjustments Created Through an Offset Request</a> on page 1297

**Offset Request - Log**

The **Log** tab contains the following zone:

- [Offset Request Log](#) on page 1296

**Offset Request Log**

The **Offset Request Log** zone lists the complete trail of actions performed on the offset request. It contains the following columns:

Column Name	Column Description
Creation Date Time	Displays the date and time when the action was performed on the offset request.
Details	Displays the details about the action performed on the offset request.
User	Indicates the user who has performed the action on the offset request.
Log Type	Indicates the type of the log.
Related Object	Indicates the object or entity which is created when the action is performed on the offset request.  <b>Note:</b> At present, no data appears in this column. The implementation team can build the custom logic to meet the business requirements.



Column Name	Column Description
Status Reason	Indicates the reason why the offset request is rejected or unapplied (i.e. canceled).

**Note:** You can manually add a log entry for the offset request by clicking the **Add Log Entry** link in the upper right corner of the **Offset Request Log** zone.

### Related Topics

For more information on...	See...
How to view the log of an offset request	<a href="#">Viewing the Log of an Offset Request</a> on page 1311
How to add a log entry for an offset request	<a href="#">Adding a Log Entry for an Offset Request</a> on page 1311

## Viewing the Debit and Credit Bills Added to an Offset Request

### Procedure

To view the debit and credit bills which are added to an offset request:

1. Search for the offset request in the **Offset Request** screen.
2. In the **Search Results** section, click the link in the **Offset Request Information** column corresponding to the offset request whose details you want to view.

The **Offset Request** screen appears.

3. Ensure that the **Main** tab is selected.
4. View the debit and credit bills added to the offset request in the **Selected Bills** zone.

### Related Topics

For more information on...	See...
How to search for an offset request	<a href="#">Searching for an Offset Request</a> on page 1283
<b>Offset Request</b> screen	<a href="#">Offset Request (Used for Viewing)</a> on page 1287
<b>Selected Bills</b> zone	<a href="#">Selected Bills</a> on page 1290

## Viewing the Adjustments Created Through an Offset Request

### Procedure

To view the adjustments created through an offset request:

1. Search for the offset request in the **Offset Request** screen.
2. In the **Search Results** section, click the link in the **Offset Request Information** column corresponding to the offset request whose details you want to view.

The **Offset Request** screen appears.

3. Ensure that the **Main** tab is selected.
4. In the **Selected Bills** zone, click the **Broadcast**  icon corresponding to the bill whose offset or transfer adjustments you want to view.

The **Offset Request Adjustments** zone appears.

**Note:** The **Broadcast**  icon appears corresponding to a bill only when the offset request is in the **Processed** or **Unapplied Offset** status.

- View the offset or transfer adjustments created for the bill through the offset request in the **Offset Request Adjustments** zone.

### Related Topics

For more information on...	See...
How to search for an offset request	<a href="#">Searching for an Offset Request</a> on page 1283
<b>Offset Request</b> screen	<a href="#">Offset Request (Used for Viewing)</a> on page 1287
<b>Selected Bills</b> zone	<a href="#">Selected Bills</a> on page 1290
<b>Offset Request Adjustments</b> zone	<a href="#">Offset Request Adjustments</a> on page 1296

## Adding a Debit or Credit Bill to an Offset Request

### Prerequisites

To add a debit or credit bill to an offset request, you should have:

- Completed bills for accounts of the main customer (whose bill is added as the primary bill in the offset request)
- Completed bills for effective child persons of the main customer (whose bill is added as the primary bill in the offset request)
- The **Allow Offsetting Across Persons** option type of the **C1-OFFSETREQ** feature configuration set to **Y** or **N** based on the business requirements

### Procedure

To add a debit or credit bill to an offset request:

- Search for the offset request in the **Offset Request** screen.
- In the **Search Results** section, click the link in the **Offset Request Information** column corresponding to the offset request whose details you want to edit.

The **Offset Request** screen appears.

- Ensure that the **Main** tab is selected.
- Enter the search criteria in the **Search Bill** zone.

#### **Note:**

The **Search Bill** zone appears only when the offset request is in the **Draft** status.

The date range specified in the **Bill Date From** and **Bill Date To** fields should not exceed the number of days specified in the **Bill Search Period** field of the respective offset request type.

ORMB search engine supports wildcard search, where you can substitute the percentage (%) symbol as a stand in for any word or letter in a search criteria. You can use the ‘%’ wildcard character in all input fields except the date and ID fields. The ‘%’ wildcard character is suffixed automatically at the end of the partial search criteria. Therefore, you may or may not specify the wildcard character at the end of the partial search criteria. However, you have to prefix the wildcard character manually wherever required.

- Click **Search**.

A list of completed bills that meet the search criteria appears in the **Search Results** section.

6. Select the check box corresponding to a completed bill that you want to add to the offset request.
7. Click the **Add** button in the **Search Bill** zone.

A message appears indicating that the bill is added to the offset request.

**Note:** You can only add a completed bill to an offset request when its outstanding amount is not equal to zero.

8. Click **OK**.

The completed bill is added to the offset request. You can view the completed bills which are added to the offset request in the **Selected Bills** zone.

**Note:** The default offset amount is calculated for each bill using the algorithm which is attached in the respective offset request type. For more information on how the default offset amount is calculated, see [CI-OFST-AMT](#) on page 1259.

### **Related Topics**

<b>For more information on...</b>	<b>See...</b>
How to search for an offset request	<a href="#">Searching for an Offset Request</a> on page 1283
<b>Offset Request</b> screen	<a href="#">Offset Request (Used for Viewing)</a> on page 1287
<b>Search Bill</b> zone	<a href="#">Search Bill</a> on page 1291
<b>Selected Bills</b> zone	<a href="#">Selected Bills</a> on page 1290
How to create an offset request	<a href="#">Creating an Offset Request</a> on page 1284
How to setup the <b>C1-OFFSETREQ</b> feature configuration	<a href="#">Setting the C1-OFFSETREQ Feature Configuration</a> on page 2917

## **Editing an Offset Request**

### **Prerequisites**

To edit an offset request, you should have:

- Adjustment types defined in the application (where the **A/P Request Type Code** field is not set to **REFUND**)

### **Procedure**

To edit an offset request:

1. Search for the offset request in the **Offset Request** screen.
2. In the **Search Results** section, click the link in the **Offset Request Information** column corresponding to the offset request whose details you want to edit.

The **Offset Request** screen appears.

3. Ensure that the **Main** tab is selected.
4. Click the **Edit** button in the **Offset Request** zone.

The **Offset Request** screen appears. It contains the following sections:

- **Main** - Used to specify the basic details about the offset request.
- **Characteristics** - Used to define characteristics for the offset request.
- **Offset Details** - Used to edit the offset amount of the bills which are added to the offset request. It also allows you to remove a bill from the offset request.

**Note:** You can only remove secondary debit or credit bills from the offset request. And, you cannot remove a primary debit or credit bill from the offset request throughout its lifecycle.

The **Main** section contains the following fields:

Field Name	Field Description	Mandatory (Yes or No)
Offset Request Information	Displays information about the offset request.	Not applicable
Offset Request Type	Indicates the offset request type using which the offset request is created.	Not applicable
Adjustment Type	Used to indicate the adjustment type using which transfer or offset adjustments must be created through the offset request.  <div style="border: 1px solid black; padding: 5px;"> <p><b>Note:</b> The <b>Search</b>  icon appears corresponding to the <b>Adjustment Type</b> field. On clicking the <b>Search</b> icon, the <b>Adjustment Type Search</b> window appears. On specifying the adjustment type, the description of the adjustment type appears corresponding to the <b>Adjustment Type</b> field.</p> </div>	Yes
Comments	Used to specify additional information about the offset request.	No

**Note:** The **Edit** button appears only when the offset request is in the **Draft** status.

5. Modify the required details in the **Main** section.
6. Define, edit, or remove characteristics from the offset request, if required.
7. Edit the offset amount of a debit or credit bill, if required.
8. Remove a debit or credit bill from the offset request, if required.
9. Click **Save**.

The changes made to the offset request are saved.

### **Related Topics**

For more information on...	See...
How to search for an offset request	<a href="#">Searching for an Offset Request</a> on page 1283
<b>Offset Request</b> screen	<a href="#">Offset Request (Used for Viewing)</a> on page 1287
<b>Offset Request</b> zone	<a href="#">Offset Request</a> on page 1287
How to define a characteristic for an offset request	<a href="#">Defining a Characteristic for an Offset Request</a> on page 1301
How to edit the offset amount of a debit or credit bill	<a href="#">Editing the Offset Amount of a Debit or Credit Bill</a> on page 1302
How to remove a debit or credit bill from an offset request	<a href="#">Removing a Debit or Credit Bill from an Offset Request</a> on page 1303

## Defining a Characteristic for an Offset Request

### Prerequisites

To define a characteristic for an offset request, you should have:

- Characteristic types defined in the application (where the characteristic entity is set to **Offset Request**)

### Procedure

To define a characteristic for an offset request:

1. Ensure that the **Characteristics** section is expanded when you are editing an offset request.

The **Characteristics** section contains the following fields in a grid:

Field Name	Field Description	Mandatory (Yes or No)
Effective Date	Used to specify the date from when the characteristic is effective for the offset request.	Yes (Conditional) <b>Note:</b> This field is required when you are defining a characteristic for the offset request.
Characteristic Type	Used to indicate the characteristic type. <b>Note:</b> The list includes only those characteristic types where the characteristic entity is set to <b>Offset Request</b> .	Yes (Conditional) <b>Note:</b> This field is required when you are defining a characteristic for the offset request.
Characteristic Value	Used to specify the value for the characteristic type. <b>Note:</b> If you select a predefined characteristic type, the <b>Search</b>  icon appears corresponding to the <b>Characteristic Value</b> field. On clicking the <b>Search</b> icon, the <b>Predefined Characteristic Search</b> window appears.  On specifying the value for a predefined characteristic type, the description of the characteristic value appears corresponding to the <b>Characteristic Value</b> field.	Yes (Conditional) <b>Note:</b> This field is required when you are defining a characteristic for the offset request.

2. Enter the required details in the **Characteristics** section.
3. If you want to define more than one characteristic for the offset request, click the **Add**  icon and then repeat step 2.

**Note:** However, if you want to remove a characteristic from the offset request, click the **Delete**  icon corresponding to the characteristic.

4. Click **Save**.

The characteristics are defined for the offset request.

**Related Topics**

For more information on...	See...
How to edit an offset request	<a href="#">Editing an Offset Request</a> on page 1299

**Editing the Offset Amount of a Debit or Credit Bill****Prerequisites**

To edit the offset amount of a debit or credit bill, you should have:

- Required debit or credit bill added in the offset request

**Procedure**

To edit the offset amount of a debit or credit bill:

1. Ensure that the **Offset Details** section is expanded when you are editing an offset request.

The **Offset Details** section contains the following fields:

Field Name	Field Description	Mandatory (Yes or No)
Total Debit Offset Amount	Displays the total offset amount of all debit bills which are included in the offset request.	Not applicable
Total Credit Offset Amount	Displays the total offset amount of all credit bills which are included in the offset request.	Not applicable
Total Offset Amount	Displays the sum of the total debit and credit offset amount.	Not applicable

In addition, this section contains the following fields in a grid:

Field Name	Field Description	Mandatory (Yes or No)
Bill ID	Indicates the debit or credit bill which is added to the offset request.	Not applicable
Outstanding Amount	Displays the outstanding amount (i.e. unpaid amount) of the debit or credit bill.	Not applicable
Due Date	Displays the date when the debit or credit bill is due for payment.	Not applicable
Hold Amount	Displays the amount of the debit or credit bill which is kept on hold through an hold request.	Not applicable
Outstanding Amount (Offset Currency)	Displays the outstanding amount (i.e. unpaid amount) of the debit or credit bill in the currency in which the bill amount would be offset.  <b>Note:</b> This field appears only when the offset request is a cross-currency offset request.	Not applicable
Offset Amount	Used to specify the amount which you want to offset from the debit or credit bill.	Yes
Remaining Bill Balance	Displays the remaining outstanding amount of the debit or credit bill (i.e. Outstanding Amount - Hold Amount - Offset Amount).	Not applicable

Field Name	Field Description	Mandatory (Yes or No)
Updated Hold Amount	Displays the new hold amount (i.e. Current Hold Amount + Remaining Bill Balance) for the debit or credit bill which is derived when the remaining bill balance is less than the current hold amount.	Not applicable

The **Delete** () icon appears corresponding to the secondary debit or credit bills in the **Offset Details** section. It allows you to remove the respective bill from the offset request.

2. Modify the offset amount of the required debit or credit bill in the **Offset Details** section.
3. Click **Save**.

The changes made to the offset request are saved.

### Related Topics

For more information on...	See...
How to edit an offset request	<a href="#">Editing an Offset Request</a> on page 1299
How to remove a debit or credit bill from an offset request	<a href="#">Removing a Debit or Credit Bill from an Offset Request</a> on page 1303

## Removing a Debit or Credit Bill from an Offset Request

### Procedure

To remove a debit or credit bill from an offset request:

1. Ensure that the **Offset Details** section is expanded when you are editing an offset request.
2. Click the **Delete** () icon corresponding to the debit or credit bill that you want to remove from the offset request.

A message appears confirming whether you want to delete the bill.

**Note:** The **Delete** () icon appears corresponding to the secondary debit or credit bills. It does not appear corresponding to the primary debit or credit bill. This is because you cannot remove a primary debit or credit bill from the offset request throughout its lifecycle.

3. Click **OK**.

The debit or credit bill is removed from the offset request.

### Related Topics

For more information on...	See...
How to edit an offset request	<a href="#">Editing an Offset Request</a> on page 1299

## Deleting an Offset Request

### Procedure

To delete an offset request:

1. Search for the offset request in the **Offset Request** screen.
2. In the **Search Results** section, click the link in the **Offset Request Information** column corresponding to the offset request that you want to delete.

The **Offset Request** screen appears.

3. Ensure that the **Main** tab is selected.
4. Click the **Delete** button in the **Offset Request** zone.

A message appears confirming whether you want to delete the offset request.

**Note:** The **Delete** button appears only when the offset request is in the **Draft** status.

5. Click **OK**.

The offset request is deleted.

### **Related Topics**

<b>For more information on...</b>	<b>See...</b>
How to search for an offset request	<a href="#">Searching for an Offset Request</a> on page 1283
<b>Offset Request</b> screen	<a href="#">Offset Request (Used for Viewing)</a> on page 1287
<b>Offset Request</b> zone	<a href="#">Offset Request</a> on page 1287

## **Submitting an Offset Request**

### **Prerequisites**

To submit an offset request, you should have:

- At least one debit and credit bills added to the offset request
- Offset amount of each bill not equal to zero
- Total debit offset amount equal to total credit offset amount in the offset request
- Negative offset amount for each debit bill and positive offset amount for each credit bill
- Offset amount less than or equal to the current outstanding amount of the bill

### **Procedure**

To submit an offset request:

1. Search for the offset request in the **Offset Request** screen.
2. In the **Search Results** section, click the link in the **Offset Request Information** column corresponding to the offset request which you want to submit.

The **Offset Request** screen appears.

3. Ensure that the **Main** tab is selected.
4. Click the **Submit** button in the **Offset Request** zone.

The system behaves in the following manner:

<b>If...</b>	<b>Then</b>
The <b>Approval Required</b> option is selected in the respective offset request type	A To Do of the <b>C1-OFSRQ</b> To Do type is created and sent to the approver. The status of the offset request is then changed to <b>Approval In Progress</b> .



If...	Then
<p>The <b>Approval Required</b> option is not selected in the respective offset request type and the number of financial transactions created for the bills (which are selected in the offset request) exceeds the defer processing count (defined in the respective offset request type)</p>	<p>The status of the offset request is changed to <b>Deferred Processing</b>. On executing the <b>Offset Request Periodic Monitor (C1-OFSRQ)</b> batch, the system considers the offset requests which are in the <b>Deferred Processing</b> status. If the <b>Transfer Adjustment</b> option is selected in the respective offset request type, the system creates the transfer adjustments using the adjustment type which is specified in the offset request. The status of the transfer adjustments is set to <b>Frozen</b>. However, if the <b>Transfer Adjustment</b> option is not selected in the respective offset request type, the system creates the offset adjustments using the adjustment type which is specified in the offset request. The status of the offset adjustments is set to <b>Frozen</b>. Finally, the status of the offset request is changed to <b>Processed</b>.</p> <p><b>Note:</b> If a match event exists for the match type entity (i.e. bill, bill segment, or contract), the existing match event is stamped on the offset or transfer adjustment and on the corresponding bill segment or bill segment cancellation financial transaction. However, if a match event does not exist, a new match event is created and stamped on the offset or transfer adjustment and on the corresponding bill segment or bill segment cancellation financial transaction. In case of partial offset, the status of the corresponding match event is set to <b>Open</b>. However, if the entire match type entity amount is offset, the status of the corresponding match event is set to <b>Balanced</b>. For more information on how the offset amount is distributed, see <a href="#">C1-OFSRQ</a> on page 1257.</p>
<p>The <b>Approval Required</b> option is not selected in the respective offset request type and the number of financial transactions created for the bills (which are selected in the offset request) does not exceed the defer processing count (defined in the respective offset request type)</p>	<p>If the <b>Transfer Adjustment</b> option is selected in the respective offset request type, the system creates the transfer adjustments using the adjustment type which is specified in the offset request. The status of the transfer adjustments is set to <b>Frozen</b>. However, if the <b>Transfer Adjustment</b> option is not selected in the respective offset request type, the system creates the offset adjustments using the adjustment type which is specified in the offset request. The status of the offset adjustments is set to <b>Frozen</b>. Finally, the status of the offset request is changed to <b>Processed</b>.</p> <p><b>Note:</b> If a match event exists for the match type entity (i.e. bill, bill segment, or contract), the existing match event is stamped on the offset or transfer adjustment and on the corresponding bill segment or bill segment cancellation financial transaction. However, if a match event does not exist, a new match event is created and stamped on the offset or transfer adjustment and on the corresponding bill segment or bill segment cancellation financial transaction. In case of partial offset, the status of the corresponding match event is set to <b>Open</b>. However, if the entire match type entity amount is offset, the status of the corresponding match event is set to <b>Balanced</b>. For more information on how the offset amount is distributed, see <a href="#">C1-OFSRQ</a> on page 1257.</p>

**Note:** The **Submit** button appears only when the offset request is in the **Draft** status.

### Related Topics

For more information on...	See...
How to search for an offset request	<a href="#">Searching for an Offset Request</a> on page 1283
<b>Offset Request</b> screen	<a href="#">Offset Request (Used for Viewing)</a> on page 1287
<b>Offset Request</b> zone	<a href="#">Offset Request</a> on page 1287

## Approving an Offset Request

You can view the number of offset requests which are pending for approval in the **Offset Request** screen. The approver can review, and accordingly approve or reject the offset request based on the observations.

**Note:** The system will not allow you to approve or reject an offset request submitted by you.

### Prerequisites

To approve an offset request, you should have:

- Approval To Do role assigned in the system

### Procedure

To approve an offset request:

1. Do either of the following:

If you want to...	Then...
Approve an offset request through the <b>Offset Request</b> screen	<ol style="list-style-type: none"> <li>1. Search for the offset request in the <b>Offset Request</b> screen.</li> <li>2. In the <b>Search Results</b> section, click the link in the <b>Offset Request Information</b> column corresponding to the offset request which you want to review.</li> </ol>
Approve an offset request through the <b>To Do List</b> screen	<ol style="list-style-type: none"> <li>1. Click the <b>Menu</b> link in the <b>Application</b> toolbar. A list appears.</li> <li>2. From the <b>Main</b> menu, select <b>To Do</b> and then click <b>To Do List</b>. The <b>To Do Type for User Search</b> window appears.</li> <li>3. Enter <b>C1-OFSRQ</b> in the <b>To Do Type</b> field.</li> <li>4. Click the <b>Search</b> button corresponding to the <b>To Do Type</b> field. The <b>To Do List</b> screen appears.</li> <li>5. Select the <b>Open</b> option from the <b>Filter by</b> list to view all unassigned To Dos.</li> <li>6. Click the link in the <b>Message</b> column corresponding to the To Do of the offset request that you want to review.</li> </ol>

The **Offset Request** screen appears.

2. Review the details in the **Offset Request** screen.
3. If the information in the offset request is accurate, click the **Approve** button in the **Offset Request** zone.

The system behaves in the following manner:

If...	Then
<p>The number of financial transactions created for the bills (which are selected in the offset request) exceeds the defer processing count (defined in the respective offset request type)</p>	<p>The status of the offset request is changed to <b>Deferred Processing</b>. On executing the <b>Offset Request Periodic Monitor (C1-OFSRQ)</b> batch, the system considers the offset requests which are in the <b>Deferred Processing</b> status. If the <b>Transfer Adjustment</b> option is selected in the respective offset request type, the system creates the transfer adjustments using the adjustment type which is specified in the offset request. The status of the transfer adjustments is set to <b>Frozen</b>. However, if the <b>Transfer Adjustment</b> option is not selected in the respective offset request type, the system creates the offset adjustments using the adjustment type which is specified in the offset request. The status of the offset adjustments is set to <b>Frozen</b>. Finally, the status of the offset request is changed to <b>Processed</b>.</p> <div style="border: 1px solid black; padding: 5px; margin-top: 10px;"> <p><b>Note:</b> If a match event exists for the match type entity (i.e. bill, bill segment, or contract), the existing match event is stamped on the offset or transfer adjustment and on the corresponding bill segment or bill segment cancelation financial transaction. However, if a match event does not exist, a new match event is created and stamped on the offset or transfer adjustment and on the corresponding bill segment or bill segment cancelation financial transaction. In case of partial offset, the status of the corresponding match event is set to <b>Open</b>. However, if the entire match type entity amount is offset, the status of the corresponding match event is set to <b>Balanced</b>. For more information on how the offset amount is distributed, see <a href="#">C1-OFST-DIST</a> on page 1257.</p> </div>

If...	Then
<p>The number of financial transactions created for the bills (which are selected in the offset request) does not exceed the defer processing count (defined in the respective offset request type)</p>	<p>If the <b>Transfer Adjustment</b> option is selected in the respective offset request type, the system creates the transfer adjustments using the adjustment type which is specified in the offset request. The status of the transfer adjustments is set to <b>Frozen</b>. However, if the <b>Transfer Adjustment</b> option is not selected in the respective offset request type, the system creates the offset adjustments using the adjustment type which is specified in the offset request. The status of the offset adjustments is set to <b>Frozen</b>. Finally, the status of the offset request is changed to <b>Processed</b>.</p> <p><b>Note:</b> If a match event exists for the match type entity (i.e. bill, bill segment, or contract), the existing match event is stamped on the offset or transfer adjustment and on the corresponding bill segment or bill segment cancellation financial transaction. However, if a match event does not exist, a new match event is created and stamped on the offset or transfer adjustment and on the corresponding bill segment or bill segment cancellation financial transaction. In case of partial offset, the status of the corresponding match event is set to <b>Open</b>. However, if the entire match type entity amount is offset, the status of the corresponding match event is set to <b>Balanced</b>. For more information on how the offset amount is distributed, see <a href="#">C1-OFST-DIST</a> on page 1257.</p>

**Note:** The **Approve** button appears only when:

- The offset request is in the **Approval In Progress** status.
- A user with the approval To Do role is reviewing the offset request.

### Related Topics

For more information on...	See...
How to search for an offset request	<a href="#">Searching for an Offset Request</a> on page 1283
<b>Offset Request</b> screen	<a href="#">Offset Request (Used for Viewing)</a> on page 1287
<b>Offset Request</b> zone	<a href="#">Offset Request</a> on page 1287

## Rejecting an Offset Request

### Prerequisites

To reject an offset request, you should have:

- Reasons defined for the **Rejected** status of the **C1-OffsetRequest** business object in the **Status Reason** screen

**Note:** The system will not allow you to approve or reject an offset request submitted by you.

### Procedure

To reject an offset request:

1. Do either of the following:

If you want to...	Then...
Reject an offset request through the <b>Offset Request</b> screen	<ol style="list-style-type: none"> <li>1. Search for the offset request in the <b>Offset Request</b> screen.</li> <li>2. In the <b>Search Results</b> section, click the link in the <b>Offset Request Information</b> column corresponding to the offset request which you want to review.</li> </ol>
Reject an offset request through the <b>To Do List</b> screen	<ol style="list-style-type: none"> <li>1. Click the <b>Menu</b> link in the <b>Application</b> toolbar. A list appears.</li> <li>2. From the <b>Main</b> menu, select <b>To Do</b> and then click <b>To Do List</b>. The <b>To Do Type for User Search</b> window appears.</li> <li>3. Enter <b>C1-OFSRQ</b> in the <b>To Do Type</b> field.</li> <li>4. Click the <b>Search</b> button corresponding to the <b>To Do Type</b> field. The <b>To Do List</b> screen appears.</li> <li>5. Select the <b>Open</b> option from the <b>Filter by</b> list to view all unassigned To Dos.</li> <li>6. Click the link in the <b>Message</b> column corresponding to the To Do of the offset request that you want to review.</li> </ol>

The **Offset Request** screen appears.

2. Review the details in the **Offset Request** screen.
3. If the information in the offset request is incorrect, click the **Reject** button in the **Offset Request** zone.

The **Reject Offset Request** window appears. It contains following fields:

Field Name	Field Description	Mandatory (Yes or No)
Status Reason	Used to indicate the reason why you want to reject the offset request.	Yes
Comments	Used to specify additional information while rejecting the offset request.	No

**Note:** The **Reject** button appears only when:

- The offset request is in the **Approval In Progress** status.
- A user with the approval To Do role is reviewing the offset request.

4. Select the reason for rejecting the offset request from the **Status Reason** list.
5. Click **Save**.

The status of the offset request is changed to **Rejected**.

### **Related Topics**

For more information on...	See...
How to search for an offset request	<a href="#">Searching for an Offset Request</a> on page 1283

For more information on...	See...
Offset Request screen	<a href="#">Offset Request (Used for Viewing)</a> on page 1287
Offset Request zone	<a href="#">Offset Request</a> on page 1287

## Unapplying an Offset Request

There might be situations when an incorrect offset request is processed in the system. In such case, the system provides you with an ability to unapply (i.e. cancel) the offset request. However, note that you can cancel an offset request only when the offset request is in the **Processed** status.

### Prerequisites

To cancel an offset request, you should have:

- Reasons defined for the **Unapplied Offset** status of the **C1-OffsetRequest** business object in the **Status Reason** screen

### Procedure

To cancel an offset request:

- Search for the offset request in the **Offset Request** screen.
- In the **Search Results** section, click the link in the **Offset Request Information** column corresponding to the offset request that you want to cancel.

The **Offset Request** screen appears.

- Click the **Unapply** button in the **Offset Request** zone.

The **Unapply Reason** window appears. It contains the following fields:

Field Name	Field Description	Mandatory (Yes or No)
Unapply Reason	Used to indicate the reason why you want to cancel the offset request.	Yes
Comments	Used to specify additional information while canceling the offset request.	No

**Note:** The **Unapply** button appears only when the offset request is in the **Processed** status.

- Select the reason for canceling the offset request from the **Unapply Reason** list.
- Click **Save**.

The system behaves in the following manner:

If...	Then...
The number of transfer or offset adjustments does not exceed the online record process limit (which is defined in the <b>C1-DFRUNAPLY</b> algorithm)	The system cancels the frozen transfer or offset adjustments immediately and then changes the status of the offset request to <b>Unapplied Offset</b> .

If...	Then...
The number of transfer or offset adjustments exceeds the online record process limit (which is defined in the <b>C1-DFRUNAPLY</b> algorithm)	The system changes the status of the offset request to <b>Defer Unapplied</b> . On executing the <b>Offset Request Periodic Monitor (C1-OFSRQ)</b> batch, the system considers the offset requests which are in the <b>Defer Unapplied</b> status. The system then cancels the frozen transfer or offset adjustments of the offset request and changes the status of the offset request to <b>Unapplied Offset</b> .

### Related Topics

For more information on...	See...
How to search for an offset request	<a href="#">Searching for an Offset Request</a> on page 1283
<b>Offset Request</b> screen	<a href="#">Offset Request (Used for Viewing)</a> on page 1287
<b>Offset Request</b> zone	<a href="#">Offset Request</a> on page 1287

## Viewing the Log of an Offset Request

### Procedure

To view the log of an offset request:

1. Search for the offset request in the **Offset Request** screen.
2. In the **Search Results** section, click the link in the **Offset Request Information** column corresponding to the offset request whose details you want to view.  
The **Offset Request** screen appears.
3. Click the **Log** tab.  
The **Log** tab appears.
4. View the complete trail of actions performed on the offset request in the **Offset Request Log** zone.

### Related Topics

For more information on...	See...
How to search for an offset request	<a href="#">Searching for an Offset Request</a> on page 1283
<b>Offset Request</b> screen	<a href="#">Offset Request (Used for Viewing)</a> on page 1287
<b>Offset Request Log</b> zone	<a href="#">Offset Request Log</a> on page 1296
How to add a log entry for an offset request	<a href="#">Adding a Log Entry for an Offset Request</a> on page 1311

## Adding a Log Entry for an Offset Request

### Procedure

To add a log entry for an offset request:

1. Search for the offset request in the **Offset Request** screen.
2. In the **Search Results** section, click the link in the **Offset Request Information** column corresponding to the offset request for which you want to add a log entry.  
The **Offset Request** screen appears.

3. Click the **Log** tab.

The **Log** tab appears.

4. Click the **Add Log Entry** link in the upper right corner of the **Offset Request Log** zone.

The **Add Request Log** window appears. It contains the following fields:

Field Name	Field Description	Mandatory (Yes or No)
Request Information	Displays information about the offset request.	Not applicable
Log Details	Used to specify additional comments on the offset request.	Yes

5. Enter the comments in the **Log Details** field.

6. Click **Save**.

The log entry is added in the **Offset Request Log** zone.

### **Related Topics**

For more information on...	See...
How to search for an offset request	<a href="#">Searching for an Offset Request</a> on page 1283
<b>Offset Request</b> screen	<a href="#">Offset Request (Used for Viewing)</a> on page 1287
<b>Offset Request Log</b> zone	<a href="#">Offset Request Log</a> on page 1296



---

# Chapter 20

---

## Funding Request

---

### Topics:

- [Prerequisites](#)
- [Funding Request \(Without Approval\) Status Transition](#)
- [Funding Request \(With Approval\) Status Transition](#)
- [Algorithms Used in C1-FundingReq](#)
- [Funding Request Type](#)
- [Funding Request \(Used for Searching\)](#)
- [Funding Request \(Used for Viewing\)](#)

Oracle Revenue Management and Billing provides the automatic payment facility for an account. The system automatically calculates the automatic payment amount during the bill completion and stamps these details against the bill in the **CI\_BILL\_ACH** table. However, there might be situations when you would like to do the following before stamping the automatic payment amount against the bill in the **CI\_BILL\_ACH** table:

- Hold certain amount on the bill through a hold request
- Offset the bill against another bill through an offset request
- Transfer the amount on the credit bill to one or more garnishment contracts of the account

The system enables you to change the automatic payment amount through the funding process. The funding process supports all three automatic payment creation options (i.e. Create At Bill Completion, Create On Extract Date, and Freeze Payment on Notification).

While creating a funding request, you need to specify a funding request type using which you want to create the funding request. It is the funding request type which helps the system to determine:

- The business object using which the funding request should be created in the system.
- The currency in which the total debit and credit amount should be calculated.
- The account funding currency characteristic type which must be defined on the account. This characteristic indicates that the funding amount of the account's bills should be calculated in the specified currency.
- The default funding adjustment type using which the A/P adjustment should be created against a credit bill.

**Note:** In the **Default Funding Adjustment Type** field, you can only specify an adjustment type where the **A/P Request Type Code** field is set to **REFUND**.

- The default garnishment adjustment type using which the garnishment adjustment should be created when the amount from the credit bill is transferred to the garnishment contract of the account.

**Note:** In the **Default Garnishment Adjustment Type** field, you can only specify an adjustment type where the **A/P Request Type Code** field is not set to **REFUND**.

- Whether the approval is required for the funding request.

- An algorithm which helps to calculate the threshold range for a bill based on the number of payments made for the bill in the specified period.
- Whether a funding request must be processed in the deferred mode when the number of bills in the funding request exceeds the defer processing count.
- The currency conversion algorithms which must be used while determining the approval hierarchy for the funding request.

**Note:** The **Funding Request (C1-FundingReq)** business object is shipped with the product.

Once you specify a funding request type, the funding request is created in the **Draft** status. You can then add one or more debit or credit bills in the funding request. Note that you can only add bills of those accounts for which the **Defer Auto Pay** option is selected on the customer class. Once the bills are added, you can submit a funding request. Before you submit a funding request, you can do the following:

- Hold certain amount on the bill through a hold request
- Offset the bill against another bill through an offset request
- Transfer the amount on the credit bill to one or more garnishment contracts of the account

**Note:** The garnishment contract is a contract which is created using a contract type where the **Special Role Flag** field is set to **Garnishment**.

The system calculates the funding amount in the following manner:

Bill Type	Funding Amount for the Bill
Debit Bill	Outstanding Bill Amount – Hold Amount (set on the bill in a hold request) – Offset Amount (set on the bill in an offset request)
Credit Bill	Outstanding Bill Amount – Hold Amount (set on the bill in a hold request) – Offset Amount (set on the bill in an offset request) – Garnishment Amount (set on the bill in the funding request)

You can delete, cancel, or submit a funding request which is in the **Draft** status. On canceling a funding request, the status of all records in the funding request is changed to **Excluded** and the status of the funding request is changed to **Canceled**. On submitting a funding request, the status of the funding request is changed to either **Deferred Processing** or **Create Funding** depending on whether the number of bills in the funding request exceeds the defer processing count. Once the **Funding Request Periodic Monitor (C1-FNDRQ)** batch is executed, it checks whether there are any funding requests in the **Deferred Processing** status. If so, it changes the status of the funding request to **Create Funding**.

Once the status of a funding request is changed to **Create Funding**, the system creates the A/P adjustment against a bill when the funding amount of the bill is in credit. It also creates non A/P adjustments using the garnishment adjustment type when the funding amount of a credit bill is transferred to the garnishment contracts of the account. However, if the funding amount of a bill is in debit, the funding amount is stamped as the automatic payment amount against the bill in the **CI\_BILL\_ACH** table. Then, on executing the **Create Automatic**

**Payments and Refunds (APAYCRET)** batch, the system creates automatic payment and payment event for such bill.

You can optionally configure the approval process for the funding request. If the **Approval Required** option is selected in the funding request type, the status of the funding request is changed to **Approval In Progress** on submitting the funding request. The system calculates the sum of total debit and credit amount in the funding request. Depending on whether the sum total is debit or credit, the system uses the debit or credit hierarchy in the approval profile (which is specified in the funding request type), respectively. If the sum total is less than the minimum threshold amount, the system automatically approves the funding request and changes the status of the funding request to either **Deferred Processing** or **Create Funding** depending on whether the number of bills in the funding request exceeds the defer processing count. However, if the sum total is equal to or greater than the threshold amount specified at the first level in the approval hierarchy, the system creates a To Do using the To Do type specified in the approval profile and assigns it to the users with the To Do role defined at the first level in the approval hierarchy.

Once the approver at the first level in the approval hierarchy approves the funding request, the system checks whether the sum total of the debit and credit amount is equal to or greater than the threshold amount specified at the next level in the approval hierarchy. If the sum total of the debit and credit amount is equal to or greater than the threshold amount specified at the next level in the approval hierarchy, the system changes the status of the funding request to **Approval In Progress**. However, if the sum total of the debit and credit amount is less than the threshold amount specified at the next level in the approval hierarchy, the system changes the status of the funding request to either **Deferred Processing** or **Create Funding** depending on whether the number of bills in the funding request exceeds the defer processing count.

If an approver rejects a funding request, the status of the funding request is changed to **Rejected**. And, if an approver requests to resubmit a funding request for approval, the status of the funding request is changed to **Draft**. You can then edit the funding request and resubmit it for approval. The system allows the submitter to withdraw the funding request when it is in the **Approval In Progress** status. On withdrawing a funding request, the status of the funding request is changed to **Draft**.

If a funding request is created automatically through a custom batch, the system allows you to manually exclude some bills from the funding request when it is in the **Draft** status. You can exclude a bill from a funding request by changing its status to **Excluded**.

For more information on how to setup the funding request process, see [Prerequisites](#) on page 1316.

## Prerequisites

---

To setup the funding request process, you need to do the following:

- Define the required funding request types in the system
- Define the required funding adjustment types where the **A/P Request Type Code** field is set to **REFUND**
- Define the required garnishment adjustment types where the **A/P Request Type Code** field is not set to **REFUND**
- Define the required characteristic types where the characteristic entity is set to **Funding Request Type**
- Define the required characteristic types where the characteristic entity is set to **Funding Request**
- Define the required approval profiles with the debit and credit approval hierarchy in the system
- Specify the **C1-FNDAP** To Do type in the approval profile which you want to use in the funding request's approval process
- Specify the **C1-FNDSB** as the submitter To Do type in the funding request types
- Define the status reasons for the **Rejected** status of the **C1-FundingRequest** business object in the **Status Reason** screen
- Assign the **C1-FNDAP** To Do type to a To Do role whose users must receive a To Do while submitting a funding request for approval
- Assign the **C1-FNDSB** To Do type to a To Do role whose users must receive a To Do when an approver requests to resubmit the funding request for approval
- Select the **Defer Auto Pay** option on the customer class of the accounts for which you want to use the funding process
- Define the values for the **CAN\_RSN\_CD\_FLG** lookup field
- Define the **Funding Currency** characteristic type where the characteristic entity is set to **Account**
- Define a currency conversion algorithm for payments using the **C1\_CURALGPY** or **C1\_EXCRTPY** algorithm type
- Define a currency conversion algorithm for adjustments using the **C1\_CURALGAD** or **C1\_EXCRTAD** algorithm type
- Attach the currency conversion algorithms to the **Currency Conversion For Adjustments** and **Currency Conversion For Payments** algorithm spots to the required divisions
- Set the batch control type of the **Funding Request Periodic Monitor (C1-FNDRQ)** batch to **Timed** and define the following attributes:
  - Time Interval
  - Timer Active
  - User ID
  - Batch Language
  - Email Address

## Funding Request (Without Approval) Status Transition

---

The following figure graphically indicates how a funding request moves from one status to another when the approval process is not configured in the funding request type:

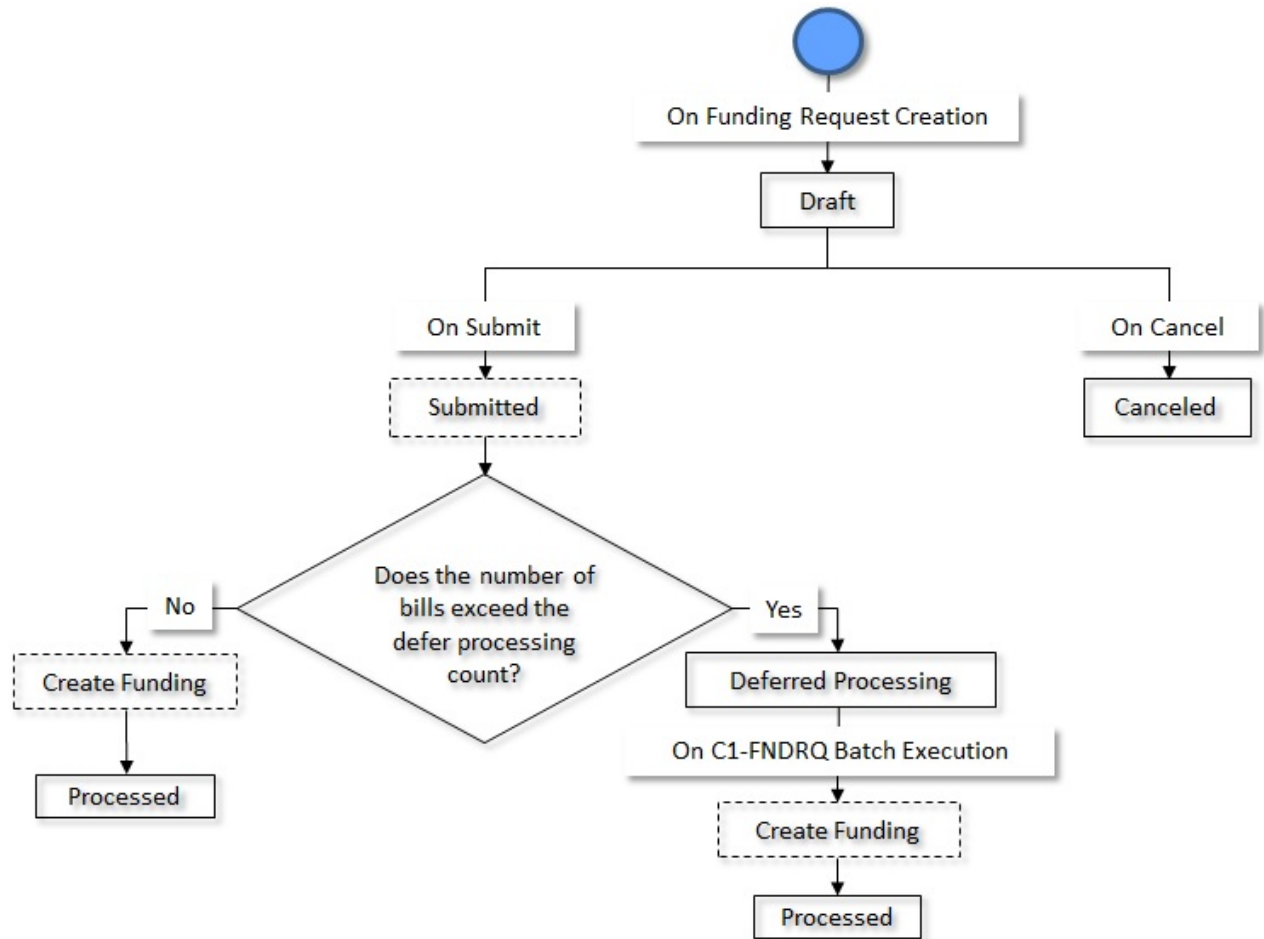

## Funding Request (With Approval) Status Transition

The following figure graphically indicates how a funding request moves from one status to another when the approval process is configured in the funding request type:

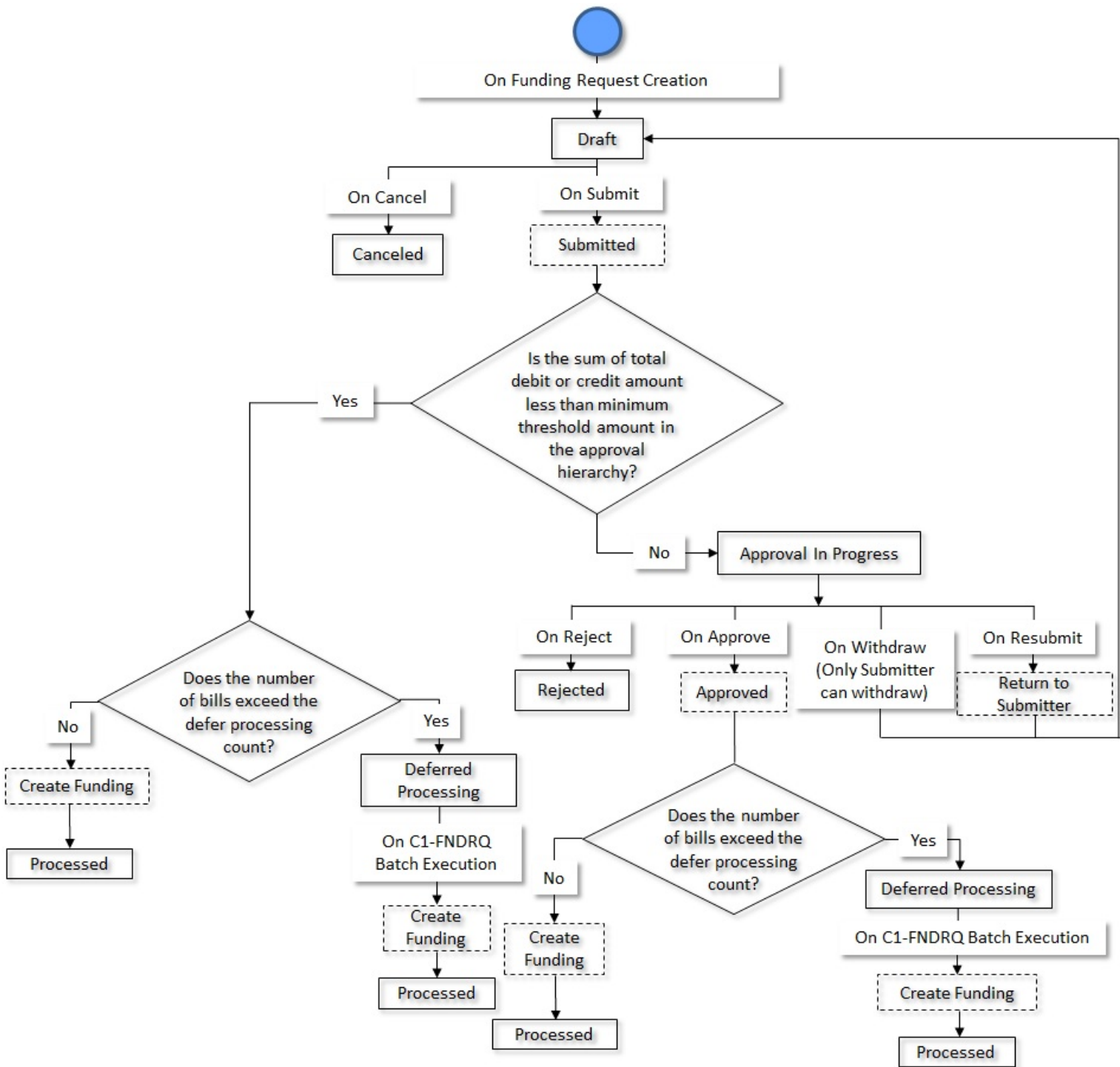

## Algorithms Used in C1-FundingReq

The following table lists the algorithm which is attached to the **C1-FundingReq** business object:

System Event	Algorithm	Algorithm Type	Description
Information	C1-FUNDINFO	C1-FUNDINFO	Refer to <a href="#">C1-FUNDINFO</a> on page 1319

The following table lists the algorithms which are used in the lifecycle of the **C1-FundingReq** business object:

Status	System Event	Algorithm	Algorithm Type	Description
Draft	Exit	F1-TODOCOMPL	F1-TODOCOMPL	Refer to <a href="#">F1-TODOCOMPL</a> on page 1256
Submitted	Enter	C1-FUNDSUBMT	C1-FUNDSUBMT	Refer to <a href="#">C1-FUNDSUBMT</a> on page 1319
Approval In Progress	Enter	C1-FUNDAPP	C1-FUNDAPP	Refer to <a href="#">C1-FUNDAPP</a> on page 1320
Approval In Progress	Exit	F1-TODOCOMPL	F1-TODOCOMPL	Refer to <a href="#">F1-TODOCOMPL</a> on page 1256
Approved	Enter	C1-FUNDAPRVD	C1-FUNDAPRVD	Refer to <a href="#">C1-FUNDAPRVD</a> on page 1320
Rejected	-	-	-	-
Deferred Processing	Monitor	F1-AT-RQJ	F1-AT-RQJ	Refer to <a href="#">F1-AT-RQJ</a> on page 1257
Return to Submitter	Enter	C1-FNDRESUBM	C1-FNDRESUBM	Refer to <a href="#">C1-FNDRESUBM</a> on page 1321
Creating Funding	Monitor	F1-AT-RQJ	F1-AT-RQJ	Refer to <a href="#">F1-AT-RQJ</a> on page 1257
Creating Funding	Enter	C1-FUNDVAL	C1-FUNDVAL	Refer to <a href="#">C1-FUNDVAL</a> on page 1321
Creating Funding	Enter	C1-FUNDAPAY	C1-FUNDAPAY	Refer to <a href="#">C1-FUNDAPAY</a> on page 1321
Creating Funding	Enter	C1-FUNDADJCR	C1-FUNDADJCR	Refer to <a href="#">C1-FUNDADJCR</a> on page 1321
Processed	-	-	-	-
Canceled	Enter	C1-FUNDCANCL	C1-FUNDCANCL	Refer to <a href="#">C1-FUNDCANCL</a> on page 1322

## C1-FUNDINFO

This algorithm generates the funding request information string which appears throughout the application. It concatenates the following fields separated by a comma in the specified order:

1. Funding Request Type Description
2. Funding Request Status Description
3. Funding Request ID

## C1-FUNDSUBMT

This algorithm is invoked when you submit a funding request. If the approval process is not configured in the funding request type, it changes the status of the funding request to either **Deferred Processing** or **Create Funding** depending on whether the number of bills in the funding request exceeds the defer processing count. If the approval process is configured in the funding request type, it calculates the sum of total debit and credit amount in the funding request. Depending on whether the sum total is debit or credit, it uses the debit or credit hierarchy in the approval profile (which is specified in the funding request type), respectively. If the sum total is less than the minimum threshold amount in the approval hierarchy, the funding request is automatically approved by the system and the status of the funding request is changed to either **Deferred Processing** or **Create Funding** depending on whether the number of bills in the funding

request exceeds the defer processing count. However, if the sum total is equal to or greater than the threshold amount specified at the first level in the approval hierarchy, the status of the funding request is changed to **Approval In Progress**.

**Note:** If the **Currency Conversion Required** option is selected in the approval profile, the system does currency conversion when the sum total of the debit and credit amount is in a currency which is different from the installation options currency. During the currency conversion of the sum total which is in debit, the system uses the currency conversion algorithm specified in the **Currency Conversion Payment Algorithm** field of the funding request type. However, during the currency conversion of the sum total which is in credit, the system uses the currency conversion algorithm specified in the **Currency Conversion Adjustment Algorithm** field of the funding request type.

## C1-FUNDAPP

This algorithm is invoked when the status of the funding request is changed to **Approval In Progress**. It creates a To Do using the To Do type specified in the approval profile and assigns it to the users with the To Do role defined at the first level in the approval hierarchy. In addition, a log entry is created for the funding request when the To Do is created.

**Note:** If a funding request needs approval from the subsequent level in the approval hierarchy, this algorithm creates a To Do and assigns it to the users with the To Do role defined at the subsequent level in the approval hierarchy.

## C1-FUNDAPRVD

This algorithm is invoked when you approve a funding request. It checks whether the sum total of the debit and credit amount is equal to or greater than the threshold amount specified at the next level in the approval hierarchy. If the sum total of the debit and credit amount is equal to or greater than the threshold amount specified at the next level in the approval hierarchy, the status of the funding request is changed to **Approval In Progress**. However, if the sum total of the debit and credit amount is less than the threshold amount specified at the next level in the approval hierarchy, the status of the funding request is changed to either **Deferred Processing** or **Create Funding** depending on whether the number of bills in the funding request exceeds the defer processing count.

**Note:** If the **Currency Conversion Required** option is selected in the approval profile, the system does currency conversion when the sum total of the debit and credit amount is in a currency which is different from the installation options currency. During the currency conversion of the sum total which is in debit, the system uses the currency conversion algorithm specified in the **Currency Conversion Payment Algorithm** field of the funding request type. However, during the currency conversion of the sum total which is in credit, the system uses the currency conversion algorithm specified in the **Currency Conversion Adjustment Algorithm** field of the funding request type.

## F1-TODOCOMPL

This algorithm completes To Do entries that are created for the business object when the business object exits the given status. It finds and completes all open To Do entries where the business object's primary key is defined as a drill key. However, if the **Exclude To Do Entries From Auto Completion** characteristic is set to **Y** for the business object, the system does not automatically complete the respective To Do entry.

## F1-AT-RQJ

This algorithm transitions the current status of the business object to the specified status. It contains the following parameters:

- **Next Status** – Used when you want to override the default next status specified in the lifecycle.
- **Next Transition Condition** – Used when you want to override the default next transition condition specified in the lifecycle.

At a time, you can specify value for either the **Next Status** or **Next Transition Condition** parameter. If you don't specify any value for these parameters, the system will transition the business object to the default next status specified in its lifecycle.



## C1-FNDRESUBM

This algorithm is invoked when the status of the funding request is changed to **Return to Submitter**. It changes the status of the funding request to **Draft**. The submitter can then make the required changes and resubmit the funding request for approval. In addition, it creates a To Do using the submitter To Do type which is specified in the funding request type. Once a To Do is created, it is assigned to all users with a submitter To Do role which is specified in the funding request type.

## C1-FUNDVAL

This algorithm is invoked when the status of the funding request is changed to **Create Funding**. It checks whether the funding amount of a debit bill is equal to the bill outstanding amount minus hold and offset amount set on the bill (i.e. Funding Amount = Outstanding Bill Amount – Hold Amount – Offset Amount). Similarly, it checks whether the funding amount of a credit bill is equal to the bill outstanding amount minus hold, offset, and garnishment amount set on the bill (i.e. Funding Amount = Outstanding Bill Amount – Hold Amount – Offset Amount – Garnishment Amount). If so, it executes the next algorithm. However, if the funding amount is incorrect, the status of the record in the funding request is changed to **Error**.

## C1-FUNDAPAY

If the funding amount of a bill is in debit, it stamps the funding amount as the automatic payment amount against the bill in the **CI\_BILL\_ACH** table. Then, on executing the **Create Automatic Payments and Refunds (APAYCRET)** batch, the system creates automatic payment and payment event for such bill.

It considers the records in the funding request which are in the **Pending** status. Once the **CI\_BILL\_ACH** table is updated, the status of the record in the funding request is changed to **Processed**. If any error occurs while updating the **CI\_BILL\_ACH** table, the status of the record in the funding request is changed to **Error**.

## C1-FUNDADJCR

If the funding amount of a bill is in credit, it creates the A/P adjustments using the funding adjustment type. It also creates non A/P adjustments using the garnishment adjustment type when the funding amount of a credit bill is transferred to the garnishment contracts of the account.

It considers the records in the funding request which are in the **Pending** status. Once the adjustments are created, the status of the record in the funding request is changed to **Processed**. If any error occurs while creating the adjustments, the status of the record in the funding request is changed to **Error**.

### **Points to Note:**

- The system uses the funding and garnishment adjustment types from the funding request.
- The main customer's address is used while creating the A/P adjustment for a credit bill.
- The garnishment adjustments are created against the garnishment contracts of the account. A garnishment contract is a contract which is created using a contract type where the **Special Role Flag** field is set to **Garnishment**.
- The system allows you to transfer funding amount to multiple garnishment contracts of the account. Accordingly, the number of non A/P adjustments will be created using the garnishment adjustment type.

It contains the following parameters:

- **Adjustment Type** - Used to indicate the adjustment type using which the adjustment should be created against the credit bill for internal offsetting.
- **Match Type Entity Flag** - Used to indicate the match type entity on which a new match event must be created when no payment exists for the credit bill. The valid values are:
  - **BILL** - Used when you want to create the same match event on all financial transactions of a bill.
  - **BSEG** - Used when you want to create a unique match event for each bill line item (such as, bill segment or adjustment).

- **SA** - Used when you want to create the same match event on the bill line items which are created against the same contract.

## C1-FUNDCANCL

This algorithm is invoked when you cancel a funding request. It excludes all debit and credit bills from the funding request and changes the status of each record in the funding request to **Excluded**. In addition, the status of the funding request is changed to **Canceled**.

## Funding Request Type

---

Oracle Revenue Management and Billing allows you to define a funding request type using which you can create a funding request. It is the funding request type which helps the system to determine the following:

- The business object using which the funding request should be created in the system.
- The currency in which the funding amount should be calculated.
- The default funding adjustment type using which the A/P adjustment should be created against a credit bill on submitting the funding request.

**Note:** In the **Default Funding Adjustment Type** field, you can only specify an adjustment type where the **A/P Request Type Code** field is set to **REFUND**.

- The default garnishment adjustment type using which the garnishment adjustment should be created when the amount from the credit bill is moved to the garnishment contract of the account.

**Note:** In the **Default Garnishment Adjustment Type** field, you can only specify an adjustment type where the **A/P Request Type Code** field is not set to **REFUND**.

- Whether the approval is required for the funding request.
- An algorithm which helps to calculate the threshold range for a bill based on the number of payments made for the bill in the specified period.
- Whether a funding request must be processed in the deferred mode when the number of bills in the funding request exceeds the defer processing count.



The **Funding Request Type** screen allows you to define, edit, delete, and copy a funding request type. It contains the following zones:

- [Funding Request Type List](#) on page 1322
- [Funding Request Type](#) on page 1323

## Funding Request Type List

The **Funding Request Type List** zone lists the funding request types that are already defined in the system. It contains the following columns:

Column Name	Column Description
Funding Request Type	Displays the funding request type.
Description	Displays the description of the funding request type.
Edit	On clicking the <b>Edit</b>  icon, the <b>Funding Request Type</b> screen appears where you can edit the details of the funding request type.

Column Name	Column Description
Duplicate	On clicking the <b>Duplicate</b> (  ) icon, the <b>Funding Request Type</b> screen appears where you can define a new funding request type using an existing funding request type.
Delete	On clicking the <b>Delete</b> (  ) icon, you can delete the funding request type.  <b>Note:</b> You can delete a funding request type only when you have not created a funding request using the funding request type.

On clicking the **Broadcast** () icon corresponding to a funding request type, the **Funding Request Type** zone appears with the details of the respective funding request type.

### Related Topics

For more information on...	See...
How to edit a funding request type	<a href="#">Editing a Funding Request Type</a> on page 1334
How to copy a funding request type	<a href="#">Copying a Funding Request Type</a> on page 1342
How to delete a funding request type	<a href="#">Deleting a Funding Request Type</a> on page 1341
How to view the details of a funding request type	<a href="#">Viewing the Funding Request Type Details</a> on page 1349

## Funding Request Type

The **Funding Request Type** zone displays the details of the funding request type. It contains of the following sections:

- **Main** - Displays the basic information about the funding request type. It contains the following fields:

Field Name	Field Description
Funding Request Type	Displays the funding request type.
Description	Displays the description of the funding request type.
Funding Request Business Object	Indicates the business object that will be used to create the funding request. In addition, a context menu appears corresponding to this field which helps in navigating to other screens in the application.  <b>Note:</b> It has a link. On clicking the link, the <b>Business Object</b> screen appears where you can view the details of the respective business object.
Detailed Description	Displays additional information about the funding request type.
Status	Indicates the status of the funding request type. The valid values are: <ul style="list-style-type: none"> <li>• Active</li> <li>• Inactive</li> </ul>
Funding Amount Currency	Indicates the currency in which the total debit and credit amount should be calculated in the funding request. The total debit and credit amount appears in the <b>Statistics</b> section of the <b>Funding Request</b> zone.
Account Funding Currency Characteristic Type	Indicates the characteristic type which should be defined on the account. This characteristic indicates that the funding amount of the account's bills should be converted in the specified currency.

Field Name	Field Description
Default Funding Adjustment Type	<p>Indicates the adjustment type using which the funding adjustments must be created.</p> <p><b>Note:</b> It has a link. On clicking the link, the <b>Adjustment Type</b> screen appears where you can view the details of the respective adjustment type.</p>
Default Garnishment Adjustment Type	<p>Indicates the garnishment adjustment type using which the garnishment adjustments must be created.</p> <p><b>Note:</b> It has a link. On clicking the link, the <b>Adjustment Type</b> screen appears with the details of the respective adjustment type.</p>
Threshold Range Algorithm	<p>Indicates the threshold range for a bill based on the payments done for the bill.</p> <p><b>Note:</b> It has a link. On clicking the link, the <b>Algorithm</b> screen appears where you can view the details of the respective algorithm.</p>
Defer Processing Count	<p>Displays the number of bills to determine if the funding request will be processed in deferred mode.</p> <p><b>Note:</b> If the number of bills is less than the <b>Defer Processing Count</b>, the funding request will be processed in real time (i.e. immediately).</p>
Approval Required	<p>Indicates whether approval is required while creating the funding adjustments using the funding request type.</p>
Approval Profile	<p>Indicates the approval profile which must be used to define approval hierarchy for the funding request type.</p> <p><b>Note:</b> The <b>Approval Profile</b> field appears only when the <b>Approval Required</b> check box is selected. It has a link. On clicking the link, the <b>Approval Profile</b> screen appears where you can view the details of the respective approval profile.</p>
Submitter To Do Type	<p>Indicates the To Do type for the submitter when the funding request type is resubmitted by the approver.</p> <p><b>Note:</b> The <b>Submitter To Do Type</b> field appears only when the <b>Approval Required</b> check box is selected. It has a link. On clicking the link, the <b>To Do Type</b> screen appears where you can view the details of the respective To Do type.</p>

Field Name	Field Description
Submitter To Do Role	<p>Indicates the To Do role for the submitter when the funding request type is resubmitted by the approver.</p> <div style="border: 1px solid black; padding: 5px;"> <p><b>Note:</b></p> <p>The <b>Submitter To Do Role</b> field appears only when the <b>Approval Required</b> check box is selected.</p> <p>It has a link. On clicking the link, the <b>To Do Role</b> screen appears where you can view the details of the respective To Do role.</p> </div>
Currency Conversion Adjustment Algorithm	Indicates the currency conversion algorithm. It is used while determining the approval hierarchy for a funding request when the sum total of the debit and credit amount (i.e. which is in credit) is different from the installation options currency.
Currency Conversion Payment Algorithm	Indicates the currency conversion algorithm. It is used while determining the approval hierarchy for a funding request when the sum total of the debit and credit amount (i.e. which is in debit) is different from the installation options currency.

- **Characteristics** - The **Characteristics** section lists the characteristics defined for the funding request type. It contains the following columns:

Column Name	Column Description
Characteristic Type	Indicates the characteristic type.
Characteristic Value	Displays the value of the characteristic type.

- **Record Actions** - The **Record Actions** section contains the following buttons:

Button Name	Button Description
Edit	Used to edit the details of the funding request type.
Delete	<p>Used to delete the funding request type.</p> <div style="border: 1px solid black; padding: 5px;"> <p><b>Note:</b> You can delete a funding request type only when you have not created a funding request using the funding request type.</p> </div>
Duplicate	Used to create a new funding request type using an existing funding request type.

- **Record Information** - The **Record Information** section contains the following fields:

Field Name	Field Description
Business Object	<p>Indicates the business object using which the funding request type is created. In addition, a context menu appears corresponding to this field which helps in navigating to other screens in the application.</p> <div style="border: 1px solid black; padding: 5px;"> <p><b>Note:</b> It has a link. On clicking the link, the <b>Business Object</b> screen appears where you can view the details of the respective business object.</p> </div>

By default, the **Funding Request Type** zone does not appear in the **Funding Request Type** screen. It appears only when you click the **Broadcast**  icon corresponding to the funding request type in the **Funding Request Type List** zone.

**Related Topics**

For more information on...	See...
How to define a funding request type	<a href="#">Defining a Characteristic for a Funding Request Type</a> on page 1333
How to edit a funding request type	<a href="#">Editing a Funding Request Type</a> on page 1334
How to copy a funding request type	<a href="#">Copying a Funding Request Type</a> on page 1342
How to delete a funding request type	<a href="#">Deleting a Funding Request Type</a> on page 1341
How to view the details of a funding request type	<a href="#">Viewing the Funding Request Type Details</a> on page 1349

**Defining a Funding Request Type****Prerequisites**

To define a funding request type, you should have:

- Funding request type business objects defined in the application
- Funding request business objects defined in the application
- Currencies defined in the application
- Funding adjustment types defined in the application (where the **A/P Request Type Code** field is set to **REFUND**)
- Garnishment adjustment types defined in the application (where the **A/P Request Type Code** field is not set to **REFUND**)
- A threshold range algorithm defined using the **C1-FDRTTR** algorithm type
- Required approval profiles defined in the application
- A To Do role assigned to the **C1-FNDSB** To Do type in the application
- Funding currency characteristic type defined in the application (where the characteristic entity is set to **Account**)
- A currency conversion algorithm defined for payments and adjustments using the **C1\_CURALGPY** and **C1\_CURALGAD** algorithm type, respectively

**Procedure**

To define a funding request type:

1. Click the **Admin** link in the **Application** toolbar.  
A list appears.
2. From the **Admin** menu, select **F** and then click **Funding Request Type**.  
A sub-menu appears.
3. Click the **Add** option from the **Funding Request Type** sub-menu.

The **Select Business Object** screen appears. It contains the following field:

Field Name	Field Description	Mandatory (Yes or No)
Funding Request Type Business Object	Used to indicate the business object using which you want to create the funding request type.	Yes

**Tip:** Alternatively, you can access the **Select Business Object** screen by clicking the **Add** button in the **Page Title** area of the **Funding Request Type** screen.

**Note:** The **Select Business Object** screen appears only when there are multiple funding request type business objects defined in the application. If there is only one funding request type business object defined in the application, the **Funding Request Type** screen appears.

4. Select the required funding request type business object from the respective field.
5. Click **OK**.

The **Funding Request Type** screen appears. It contains the following sections:



- **Main** - Used to specify basic details about the funding request type.
- **Characteristics** - Used to define characteristics for the funding request type.



The **Main** section contains the following fields:

Field Name	Field Description	Mandatory (Yes or No)
Funding Request Type	Used to specify the funding request type.	Yes
Business Object	Indicates the business object using which you are defining the funding request type.	Not applicable
Description	Used to specify the description for the funding request type.	Yes
Funding Request Business Object	Used to indicate the business object using which you want to create the funding request.	Yes
Detailed Description	Used to specify additional information about the funding request type.	No
Status	<p>Used to indicate the status of the funding request type. The valid values are:</p> <ul style="list-style-type: none"> <li>• Active</li> <li>• Inactive</li> </ul> <p><b>Note:</b> You cannot change the status of a funding request type to <b>Inactive</b> when the corresponding funding request is in a status other than <b>Processed</b> or <b>Rejected</b>.</p>	Yes



Field Name	Field Description	Mandatory (Yes or No)
Funding Amount Currency	<p>Used to indicate the currency in which the total debit and credit amount should be calculated in the funding request. The total debit and credit amount appears in the <b>Statistics</b> section of the <b>Funding Request</b> zone.</p> <div data-bbox="695 417 1149 1247" style="border: 1px solid black; padding: 5px;"> <p><b>Note:</b></p> <p>The list includes only those currencies which are defined in the system.</p> <p>If the currency specified in this field is different from the bill's currency, the system does currency conversion before calculating the total debit and credit amount in the funding request. The total debit amount is the sum of funding amount of all bills whose funding amount is in debit. However, the total credit amount is the sum of funding amount and garnishment amount of all bills whose funding amount is in credit. While calculating the total debit amount, the system uses the currency conversion algorithm attached to the <b>Currency Conversion For Payments</b> algorithm spot of the account's division. However, while calculating the total credit amount, the system uses the currency conversion algorithm attached to the <b>Currency Conversion For Adjustments</b> algorithm spot of the account's division.</p> </div>	Yes



Field Name	Field Description	Mandatory (Yes or No)
Account Funding Currency Characteristic Type	<p>Used to indicate the characteristic type. This characteristic should be defined on the account. This characteristic indicates that the funding amount of the account's bills should be converted in the specified currency.</p> <div data-bbox="695 415 1154 1289" style="border: 1px solid black; padding: 5px;"> <p><b>Note:</b></p> <p>The <b>Search</b>  icon appears corresponding to the <b>Account Funding Currency Characteristic Type</b> field. On clicking the <b>Search</b> icon, the <b>Characteristic Type Search</b> window appears.</p> <p>You must specify a characteristic type where the characteristic entity is set to <b>Account</b>.</p> <p>The converted amount appears in the <b>Funding Currency Amount</b> column of the <b>Selected Bills</b> zone in the <b>Funding Request</b> screen.</p> <p>If the funding amount is in debit, the system uses the currency conversion algorithm attached to the <b>Currency Conversion For Payments</b> algorithm spot of the account's division. However, if the funding amount is in credit, the system uses the currency conversion algorithm attached to the <b>Currency Conversion For Adjustments</b> algorithm spot of the account's division.</p> </div>	Yes
Default Funding Adjustment Type	<p>Used to indicate the adjustment type using which the A/P adjustment should be created against a credit bill on submitting the funding request.</p> <div data-bbox="695 1461 1154 1854" style="border: 1px solid black; padding: 5px;"> <p><b>Note:</b></p> <p>The <b>Search</b>  icon appears corresponding to the <b>Default Funding Adjustment Type</b> field. On clicking the <b>Search</b> icon, the <b>Adjustment Type Search</b> window appears.</p> <p>In the <b>Default Funding Adjustment Type</b> field, you can only specify an adjustment type where the <b>A/P Request Type Code</b> field is set to <b>REFUND</b>.</p> </div>	Yes

Field Name	Field Description	Mandatory (Yes or No)
Default Garnishment Adjustment Type	<p>Used to indicate the adjustment type using which the garnishment adjustment should be created when the amount from the credit bill is transferred to the garnishment contract of the account.</p> <div data-bbox="695 386 1149 779" style="border: 1px solid black; padding: 5px;"> <p><b>Note:</b></p> <p>The <b>Search</b>  icon appears corresponding to the <b>Default Garnishment Adjustment Type</b> field. On clicking the <b>Search</b> icon, the <b>Adjustment Type Search</b> window appears.</p> <p>In the <b>Default Garnishment Adjustment Type</b> field, you can only specify an adjustment type where the <b>A/P Request Type Code</b> field is not set to <b>REFUND</b>.</p> </div>	Yes
Threshold Range Algorithm	<p>Used to attach an algorithm which helps to calculate the threshold range for a bill based on the number of payments made for the bill in the specified period.</p> <div data-bbox="695 953 1149 1341" style="border: 1px solid black; padding: 5px;"> <p><b>Note:</b></p> <p>You must specify an algorithm which is created using the <b>C1-FDRTTR</b> algorithm type in the <b>Threshold Range Algorithm</b> field.</p> <p>The <b>Search</b>  icon appears corresponding to the <b>Threshold Range Algorithm</b> field. On clicking the <b>Search</b> icon, the <b>Algorithm Search</b> window appears.</p> </div>	No

Field Name	Field Description	Mandatory (Yes or No)
Defer Processing Count	<p>Used to indicate whether a funding request must be processed in the deferred mode (i.e. in the background) when the number of bills in the funding request exceeds the defer processing count.</p> <div data-bbox="695 386 1149 1010" style="border: 1px solid black; padding: 5px;"> <p><b>Note:</b> You cannot specify a negative value in the <b>Defer Processing Count</b> field.</p> <p>Deferred mode means in the background when the <b>Funding Request Periodic Monitor (C1-FNDRQ)</b> batch is invoked. You can configure the <b>Funding Request Periodic Monitor (C1-FNDRQ)</b> batch such that it is executed at regular intervals. For more information about the <b>Funding Request Periodic Monitor (C1-FNDRQ)</b> batch, refer to <i>Oracle Revenue Management and Billing Batch Guide</i>.</p> <p>If the number of bills in a funding request does not exceed the defer processing count, the system will process the funding request in real time (i.e. immediately).</p> </div>	No
Approval Required	Used to indicate whether the approval is required before creating payments for debit bills and A/P adjustments for credit bills through the funding request.	No
Approval Profile	<p>Used to indicate the approval profile using which the system should determine the debit or credit hierarchy level from where the approval is required. The system considers the debit or credit hierarchy level where the funding amount of the debit or credit bill falls within the threshold limit.</p> <div data-bbox="695 1423 1149 1507" style="border: 1px solid black; padding: 5px;"> <p><b>Note:</b> This field appears only when the <b>Approval Required</b> option is selected.</p> </div>	<p>Yes (Conditional)</p> <div data-bbox="1170 1230 1463 1377" style="border: 1px solid black; padding: 5px;"> <p><b>Note:</b> This field is required when the <b>Approval Required</b> option is selected.</p> </div>

Field Name	Field Description	Mandatory (Yes or No)
Submitter To Do Type	<p>Used to indicate that To Do entry of the specified To Do type must be created when the approver rejects the funding request or raises the request for resubmitting the funding request.</p> <p><b>Note:</b> You must specify the <b>C1-FNDSB To Do</b> type in the <b>Submitter To Do Type</b> field.</p> <p>The <b>Search</b>  icon appears corresponding to the <b>Submitter To Do Type</b> field. On clicking the <b>Search</b> icon, the <b>To Do Type Search</b> window appears.</p> <p>This field appears only when the <b>Approval Required</b> option is selected.</p>	<p>Yes (Conditional)</p> <p><b>Note:</b> This field is required when the <b>Approval Required</b> option is selected.</p>
Submitter To Do Role	<p>Used to indicate that the users with the specified To Do role must receive a To Do when the approver rejects the funding request or raises the request for resubmitting the funding request.</p> <p><b>Note:</b> This field appears only when the <b>Approval Required</b> option is selected.</p> <p>The list includes only those To Do roles which are associated to the specified submitter To Do type.</p>	<p>Yes (Conditional)</p> <p><b>Note:</b> This field is required when the <b>Approval Required</b> option is selected.</p>
Currency Conversion Adjustment Algorithm	<p>Used to indicate the currency conversion algorithm. It is used while determining the approval hierarchy for a funding request when the sum total of the debit and credit amount (i.e. which is in credit) is different from the installation options currency.</p> <p><b>Note:</b> This field appears only when the <b>Approval Required</b> option is selected.</p> <p>The <b>Search</b>  icon appears corresponding to the <b>Currency Conversion Adjustment Algorithm</b> field. On clicking the <b>Search</b> icon, the <b>Algorithm Search</b> window appears.</p>	<p>Yes (Conditional)</p> <p><b>Note:</b> This field is required when the <b>Currency Conversion Required</b> option is selected in the approval profile.</p>

Field Name	Field Description	Mandatory (Yes or No)
Currency Conversion Payment Algorithm	<p>Used to indicate the currency conversion algorithm. It is used while determining the approval hierarchy for a funding request when the sum total of the debit and credit amount (i.e. which is in debit) is different from the installation options currency.</p> <p><b>Note:</b> This field appears only when the <b>Approval Required</b> option is selected.</p> <p>The <b>Search</b>  icon appears corresponding to the <b>Currency Conversion Payment Algorithm</b> field. On clicking the <b>Search</b> icon, the <b>Algorithm Search</b> window appears.</p>	<p>Yes (Conditional)</p> <p><b>Note:</b> This field is required when the <b>Currency Conversion Required</b> option is selected in the approval profile.</p>

6. Enter the required details in the **Main** section.
7. Define characteristics for the funding request type, if required.
8. Click **Save**.

The funding request type is defined.

#### Related Topics

For more information on...	See...
<b>Funding Request Type</b> screen	<a href="#">Funding Request Type</a> on page 1322
How to define a characteristic for a funding request type	<a href="#">Defining a Characteristic for a Funding Request Type</a> on page 1333

## Defining a Characteristic for a Funding Request Type

### Prerequisites

To define a characteristic for a funding request type, you should have:

- Characteristic types defined in the application (where the characteristic entity is set to **Funding Request Type**)

### Procedure

To define a characteristic for a funding request type:

1. Ensure that the **Characteristics** section is expanded when you are defining, editing, or copying a funding request type.

The **Characteristics** section contains the following fields in a grid:

Field Name	Field Description	Mandatory (Yes or No)
Characteristic Type	Used to indicate the characteristic type.  <b>Note:</b> The list includes only those characteristic types where the characteristic entity is set to <b>Funding Request Type</b> .	Yes (Conditional)  <b>Note:</b> This field is required when you are defining a characteristic for the funding request type.
Characteristic Value	Used to specify the value for the characteristic type.  <b>Note:</b> If you select a predefined characteristic type, the <b>Search</b>  icon appears corresponding to the <b>Characteristic Value</b> field. On clicking the <b>Search</b> icon, you can search for a predefined characteristic value.  On specifying the value for a predefined characteristic type, the description of the characteristic value appears corresponding to the <b>Characteristic Value</b> field.	Yes (Conditional)  <b>Note:</b> This field is required when you are defining a characteristic for the funding request type.

- Enter the required details in the **Characteristics** section.
- If you want to define more than one characteristic for the funding request type, click the **Add**  icon and then repeat step 2.

**Note:** However, if you want to remove a characteristic from the funding request type, click the **Delete**  icon corresponding to the characteristic.

### Related Topics

For more information on...	See...
How to define a funding request type	<a href="#">Defining a Funding Request Type</a> on page 1326
How to edit a funding request type	<a href="#">Editing a Funding Request Type</a> on page 1334
How to copy a funding request type	<a href="#">Copying a Funding Request Type</a> on page 1342

## Editing a Funding Request Type

### Prerequisites

To edit a funding request type, you should have:

- Funding request business objects defined in the application
- Currencies defined in the application
- Funding adjustment types defined in the application (where the **A/P Request Type Code** field is set to **REFUND**)

- Garnishment adjustment types defined in the application (where the **A/P Request Type Code** field is not set to **REFUND**)
- A threshold range algorithm defined using the **C1-FDRTTR** algorithm type
- Required approval profiles defined in the application
- A To Do role assigned to the **C1-FNDSB** To Do type in the application
- Funding currency characteristic type defined in the application (where the characteristic entity is set to **Account**)
- A currency conversion algorithm defined for payments and adjustments using the **C1\_CURALGPY** and **C1\_CURALGAD** algorithm type, respectively

### Procedure

To edit a funding request type:

1. Click the **Admin** link in the **Application** toolbar.  
A list appears.
2. From the **Admin** menu, select **F** and then click **Funding Request Type**.  
A sub-menu appears.
3. Click the **Search** option from the **Funding Request Type** sub-menu.  
The **Funding Request Type** screen appears.
4. In the **Funding Request Type List** zone, click the **Edit** (✎) icon in the **Edit** column corresponding to the funding request type whose details you want to edit.

The **Funding Request Type** screen appears. It contains the following sections:



- **Main** - Used to specify basic details about the funding request type.
- **Characteristics** - Used to define characteristics for the funding request type.



The **Main** section contains the following fields:

Field Name	Field Description	Mandatory (Yes or No)
Funding Request Type	Displays the funding request type.	Not applicable
Business Object	Indicates the business object using which you are defining the funding request type.	Not applicable
Description	Used to specify the description for the funding request type.	Yes
Funding Request Business Object	Used to indicate the business object using which you want to create the funding request.	Yes
Detailed Description	Used to specify additional information about the funding request type.	No



Field Name	Field Description	Mandatory (Yes or No)
Status	<p>Used to indicate the status of the funding request type. The valid values are:</p> <ul style="list-style-type: none"> <li>• Active</li> <li>• Inactive</li> </ul> <p><b>Note:</b> You cannot change the status of a funding request type to <b>Inactive</b> when the corresponding funding request is in a status other than <b>Processed</b> or <b>Rejected</b>.</p>	Yes
Funding Amount Currency	<p>Used to indicate the currency in which the total debit and credit amount should be calculated in the funding request. The total debit and credit amount appears in the <b>Statistics</b> section of the <b>Funding Request</b> zone.</p> <p><b>Note:</b> The list includes only those currencies which are defined in the system.</p> <p>If the currency specified in this field is different from the bill's currency, the system does currency conversion before calculating the total debit and credit amount in the funding request. The total debit amount is the sum of funding amount of all bills whose funding amount is in debit. However, the total credit amount is the sum of funding amount and garnishment amount of all bills whose funding amount is in credit. While calculating the total debit amount, the system uses the currency conversion algorithm attached to the <b>Currency Conversion For Payments</b> algorithm spot of the account's division. However, while calculating the total credit amount, the system uses the currency conversion algorithm attached to the <b>Currency Conversion For Adjustments</b> algorithm spot of the account's division.</p>	Yes



Field Name	Field Description	Mandatory (Yes or No)
Account Funding Currency Characteristic Type	<p>Used to indicate the characteristic type. This characteristic should be defined on the account. This characteristic indicates that the funding amount of the account's bills should be converted in the specified currency.</p> <p><b>Note:</b></p> <p>The <b>Search</b>  icon appears corresponding to the <b>Account Funding Currency Characteristic Type</b> field. On clicking the <b>Search</b> icon, the <b>Characteristic Type Search</b> window appears.</p> <p>You must specify a characteristic type where the characteristic entity is set to <b>Account</b>.</p> <p>The converted amount appears in the <b>Funding Currency Amount</b> column of the <b>Selected Bills</b> zone in the <b>Funding Request</b> screen.</p> <p>If the funding amount is in debit, the system uses the currency conversion algorithm attached to the <b>Currency Conversion For Payments</b> algorithm spot of the account's division. However, if the funding amount is in credit, the system uses the currency conversion algorithm attached to the <b>Currency Conversion For Adjustments</b> algorithm spot of the account's division.</p>	Yes
Default Funding Adjustment Type	<p>Used to indicate the adjustment type using which the A/P adjustment should be created against a credit bill on submitting the funding request.</p> <p><b>Note:</b></p> <p>The <b>Search</b>  icon appears corresponding to the <b>Default Funding Adjustment Type</b> field. On clicking the <b>Search</b> icon, the <b>Adjustment Type Search</b> window appears.</p> <p>In the <b>Default Funding Adjustment Type</b> field, you can only specify an adjustment type where the <b>A/P Request Type Code</b> field is set to <b>REFUND</b>.</p>	Yes

Field Name	Field Description	Mandatory (Yes or No)
Default Garnishment Adjustment Type	<p>Used to indicate the adjustment type using which the garnishment adjustment should be created when the amount from the credit bill is transferred to the garnishment contract of the account.</p> <div data-bbox="690 386 1149 779" style="border: 1px solid black; padding: 5px;"> <p><b>Note:</b></p> <p>The <b>Search</b>  icon appears corresponding to the <b>Default Garnishment Adjustment Type</b> field. On clicking the <b>Search</b> icon, the <b>Adjustment Type Search</b> window appears.</p> <p>In the <b>Default Garnishment Adjustment Type</b> field, you can only specify an adjustment type where the <b>A/P Request Type Code</b> field is not set to <b>REFUND</b>.</p> </div>	Yes
Threshold Range Algorithm	<p>Used to attach an algorithm which helps to calculate the threshold range for a bill based on the number of payments made for the bill in the specified period.</p> <div data-bbox="690 953 1149 1341" style="border: 1px solid black; padding: 5px;"> <p><b>Note:</b></p> <p>You must specify an algorithm which is created using the <b>C1-FDRTTR</b> algorithm type in the <b>Threshold Range Algorithm</b> field.</p> <p>The <b>Search</b>  icon appears corresponding to the <b>Threshold Range Algorithm</b> field. On clicking the <b>Search</b> icon, the <b>Algorithm Search</b> window appears.</p> </div>	No

Field Name	Field Description	Mandatory (Yes or No)
Defer Processing Count	<p>Used to indicate whether a funding request must be processed in the deferred mode (i.e. in the background) when the number of bills in the funding request exceeds the defer processing count.</p> <div data-bbox="690 386 1149 1010" style="border: 1px solid black; padding: 5px;"> <p><b>Note:</b> You cannot specify a negative value in the <b>Defer Processing Count</b> field.</p> <p>Deferred mode means in the background when the <b>Funding Request Periodic Monitor (C1-FNDRQ)</b> batch is invoked. You can configure the <b>Funding Request Periodic Monitor (C1-FNDRQ)</b> batch such that it is executed at regular intervals. For more information about the <b>Funding Request Periodic Monitor (C1-FNDRQ)</b> batch, refer to <i>Oracle Revenue Management and Billing Batch Guide</i>.</p> <p>If the number of bills in a funding request does not exceed the defer processing count, the system will process the funding request in real time (i.e. immediately).</p> </div>	No
Approval Required	Used to indicate whether the approval is required before creating payments for debit bills and A/P adjustments for credit bills through the funding request.	No
Approval Profile	<p>Used to indicate the approval profile using which the system should determine the debit or credit hierarchy level from where the approval is required. The system considers the debit or credit hierarchy level where the funding amount of the debit or credit bill falls within the threshold limit.</p> <div data-bbox="690 1423 1149 1507" style="border: 1px solid black; padding: 5px;"> <p><b>Note:</b> This field appears only when the <b>Approval Required</b> option is selected.</p> </div>	<p>Yes (Conditional)</p> <div data-bbox="1170 1230 1463 1377" style="border: 1px solid black; padding: 5px;"> <p><b>Note:</b> This field is required when the <b>Approval Required</b> option is selected.</p> </div>

Field Name	Field Description	Mandatory (Yes or No)
Submitter To Do Type	<p>Used to indicate that To Do entry of the specified To Do type must be created when the approver rejects the funding request or raises the request for resubmitting the funding request.</p> <p><b>Note:</b> You must specify the <b>C1-FNDSB To Do</b> type in the <b>Submitter To Do Type</b> field.</p> <p>The <b>Search</b>  icon appears corresponding to the <b>Submitter To Do Type</b> field. On clicking the <b>Search</b> icon, the <b>To Do Type Search</b> window appears.</p> <p>This field appears only when the <b>Approval Required</b> option is selected.</p>	<p>Yes (Conditional)</p> <p><b>Note:</b> This field is required when the <b>Approval Required</b> option is selected.</p>
Submitter To Do Role	<p>Used to indicate that the users with the specified To Do role must receive a To Do when the approver rejects the funding request or raises the request for resubmitting the funding request.</p> <p><b>Note:</b> This field appears only when the <b>Approval Required</b> option is selected.</p> <p>The list includes only those To Do roles which are associated to the specified submitter To Do type.</p>	<p>Yes (Conditional)</p> <p><b>Note:</b> This field is required when the <b>Approval Required</b> option is selected.</p>
Currency Conversion Adjustment Algorithm	<p>Used to indicate the currency conversion algorithm. It is used while determining the approval hierarchy for a funding request when the sum total of the debit and credit amount (i.e. which is in credit) is different from the installation options currency.</p> <p><b>Note:</b> This field appears only when the <b>Approval Required</b> option is selected.</p> <p>The <b>Search</b>  icon appears corresponding to the <b>Currency Conversion Adjustment Algorithm</b> field. On clicking the <b>Search</b> icon, the <b>Algorithm Search</b> window appears.</p>	<p>Yes (Conditional)</p> <p><b>Note:</b> This field is required when the <b>Currency Conversion Required</b> option is selected in the approval profile.</p>

Field Name	Field Description	Mandatory (Yes or No)
Currency Conversion Payment Algorithm	<p>Used to indicate the currency conversion algorithm. It is used while determining the approval hierarchy for a funding request when the sum total of the debit and credit amount (i.e. which is in debit) is different from the installation options currency.</p> <p><b>Note:</b> This field appears only when the <b>Approval Required</b> option is selected.</p> <p>The <b>Search</b>  icon appears corresponding to the <b>Currency Conversion Payment Algorithm</b> field. On clicking the <b>Search</b> icon, the <b>Algorithm Search</b> window appears.</p>	<p>Yes (Conditional)</p> <p><b>Note:</b> This field is required when the <b>Currency Conversion Required</b> option is selected in the approval profile.</p>

**Tip:** Alternatively, you can edit the details of a funding request type by clicking the **Edit** button in the **Funding Request Type** zone.

5. Modify the details in the **Main** section, if required.
6. Define, edit, or remove characteristics from the funding request type, if required.
7. Click **Save**.

The changes made to the funding request type are saved.

### **Related Topics**

For more information on...	See...
<b>Funding Request Type</b> screen	<a href="#">Funding Request Type</a> on page 1322
<b>Funding Request Type List</b> zone	<a href="#">Funding Request Type List</a> on page 1322
<b>Funding Request Type</b> zone	<a href="#">Funding Request Type</a> on page 1323
How to define a characteristic for a funding request type	<a href="#">Defining a Characteristic for a Funding Request Type</a> on page 1333

## **Deleting a Funding Request Type**

### **Procedure**

To delete a funding request type:

1. Click the **Admin** link in the **Application** toolbar.  
A list appears.
2. From the **Admin** menu, select **F** and then click **Funding Request Type**.  
A sub-menu appears.
3. Click the **Search** option from the **Funding Request Type** sub-menu.  
The **Funding Request Type** screen appears.

- In the **Funding Request Type List** zone, click the **Delete** (🗑️) icon in the **Delete** column corresponding to the funding request type that you want to delete.

A message appears confirming whether you want to delete the funding request type.

**Note:** You can delete a funding request type only when you have not created a funding request using the funding request type.

**Tip:** Alternatively, you can delete a funding request type by clicking the **Delete** button in the **Funding Request Type** zone.

- Click **OK**.

The funding request type is deleted.

### Related Topics

For more information on...	See...
<b>Funding Request Type</b> screen	<a href="#">Funding Request Type</a> on page 1322
<b>Funding Request Type List</b> zone	<a href="#">Funding Request Type List</a> on page 1322
<b>Funding Request Type</b> zone	<a href="#">Funding Request Type</a> on page 1323

## Copying a Funding Request Type

Instead of creating a funding request type from scratch, you can create a new funding request type using an existing funding request type. This is possible through copying a funding request type. On copying a funding request type, the details including the characteristics are copied to the new funding request type. You can then edit the details, if required.

### Prerequisites

To copy a funding request type, you should have:

- Funding request type (whose copy you want to create) defined in the application
- Funding request business objects defined in the application
- Currencies defined in the application
- Funding adjustment types defined in the application (where the **A/P Request Type Code** field is set to **REFUND**)
- Garnishment adjustment types defined in the application (where the **A/P Request Type Code** field is not set to **REFUND**)
- A threshold range algorithm defined using the **C1-FDRTTR** algorithm type
- Required approval profiles defined in the application
- A To Do role assigned to the **C1-FNDSB** To Do type in the application
- Funding currency characteristic type defined in the application (where the characteristic entity is set to **Account**)
- A currency conversion algorithm defined for payments and adjustments using the **C1\_CURALGPY** and **C1\_CURALGAD** algorithm type, respectively

### Procedure

To copy a funding request type:

- Click the **Admin** link in the **Application** toolbar.

A list appears.

- From the **Admin** menu, select **F** and then click **Funding Request Type**.

A sub-menu appears.

- Click the **Search** option from the **Funding Request Type** sub-menu.

The **Funding Request Type** screen appears.

- In the **Funding Request Type List** zone, click the **Duplicate** () icon in the **Duplicate** column corresponding to the funding request type whose copy you want to create.

The **Funding Request Type** screen appears. It contains the following sections:



- **Main** - Used to specify basic details about the funding request type.
- **Characteristics** - Used to define characteristics for the funding request type.



The **Main** section contains the following fields:

Field Name	Field Description	Mandatory (Yes or No)
Funding Request Type	Used to specify the funding request type.	Yes
Business Object	Indicates the business object using which you are defining the funding request type.	Not applicable
Description	Used to specify the description for the funding request type.	Yes
Funding Request Business Object	Used to indicate the business object using which you want to create the funding request.	Yes
Detailed Description	Used to specify additional information about the funding request type.	No
Status	Used to indicate the status of the funding request type. The valid values are: <ul style="list-style-type: none"> <li>• Active</li> <li>• Inactive</li> </ul> <div style="border: 1px solid black; padding: 5px; margin-top: 10px;"> <p><b>Note:</b> You cannot change the status of a funding request type to <b>Inactive</b> when the corresponding funding request is in a status other than <b>Processed</b> or <b>Rejected</b>.</p> </div>	Yes



Field Name	Field Description	Mandatory (Yes or No)
Funding Amount Currency	<p>Used to indicate the currency in which the total debit and credit amount should be calculated in the funding request. The total debit and credit amount appears in the <b>Statistics</b> section of the <b>Funding Request</b> zone.</p> <div data-bbox="695 422 1149 1247" style="border: 1px solid black; padding: 5px;"> <p><b>Note:</b></p> <p>The list includes only those currencies which are defined in the system.</p> <p>If the currency specified in this field is different from the bill's currency, the system does currency conversion before calculating the total debit and credit amount in the funding request. The total debit amount is the sum of funding amount of all bills whose funding amount is in debit. However, the total credit amount is the sum of funding amount and garnishment amount of all bills whose funding amount is in credit. While calculating the total debit amount, the system uses the currency conversion algorithm attached to the <b>Currency Conversion For Payments</b> algorithm spot of the account's division. However, while calculating the total credit amount, the system uses the currency conversion algorithm attached to the <b>Currency Conversion For Adjustments</b> algorithm spot of the account's division.</p> </div>	Yes



Field Name	Field Description	Mandatory (Yes or No)
Account Funding Currency Characteristic Type	<p>Used to indicate the characteristic type. This characteristic should be defined on the account. This characteristic indicates that the funding amount of the account's bills should be converted in the specified currency.</p> <div data-bbox="695 422 1149 1255" style="border: 1px solid black; padding: 5px;"> <p><b>Note:</b></p> <p>The <b>Search</b>  icon appears corresponding to the <b>Account Funding Currency Characteristic Type</b> field. On clicking the <b>Search</b> icon, the <b>Characteristic Type Search</b> window appears.</p> <p>You must specify a characteristic type where the characteristic entity is set to <b>Account</b>.</p> <p>The converted amount appears in the <b>Funding Currency Amount</b> column of the <b>Selected Bills</b> zone in the <b>Funding Request</b> screen.</p> <p>If the funding amount is in debit, the system uses the currency conversion algorithm attached to the <b>Currency Conversion For Payments</b> algorithm spot of the account's division. However, if the funding amount is in credit, the system uses the currency conversion algorithm attached to the <b>Currency Conversion For Adjustments</b> algorithm spot of the account's division.</p> </div>	Yes
Default Funding Adjustment Type	<p>Used to indicate the adjustment type using which the A/P adjustment should be created against a credit bill on submitting the funding request.</p> <div data-bbox="695 1430 1149 1822" style="border: 1px solid black; padding: 5px;"> <p><b>Note:</b></p> <p>The <b>Search</b>  icon appears corresponding to the <b>Default Funding Adjustment Type</b> field. On clicking the <b>Search</b> icon, the <b>Adjustment Type Search</b> window appears.</p> <p>In the <b>Default Funding Adjustment Type</b> field, you can only specify an adjustment type where the <b>A/P Request Type Code</b> field is set to <b>REFUND</b>.</p> </div>	Yes

Field Name	Field Description	Mandatory (Yes or No)
Default Garnishment Adjustment Type	<p>Used to indicate the adjustment type using which the garnishment adjustment should be created when the amount from the credit bill is transferred to the garnishment contract of the account.</p> <div data-bbox="695 386 1146 779" style="border: 1px solid black; padding: 5px;"> <p><b>Note:</b></p> <p>The <b>Search</b>  icon appears corresponding to the <b>Default Garnishment Adjustment Type</b> field. On clicking the <b>Search</b> icon, the <b>Adjustment Type Search</b> window appears.</p> <p>In the <b>Default Garnishment Adjustment Type</b> field, you can only specify an adjustment type where the <b>A/P Request Type Code</b> field is not set to <b>REFUND</b>.</p> </div>	Yes
Threshold Range Algorithm	<p>Used to attach an algorithm which helps to calculate the threshold range for a bill based on the number of payments made for the bill in the specified period.</p> <div data-bbox="695 953 1146 1341" style="border: 1px solid black; padding: 5px;"> <p><b>Note:</b></p> <p>You must specify an algorithm which is created using the <b>C1-FDRTTR</b> algorithm type in the <b>Threshold Range Algorithm</b> field.</p> <p>The <b>Search</b>  icon appears corresponding to the <b>Threshold Range Algorithm</b> field. On clicking the <b>Search</b> icon, the <b>Algorithm Search</b> window appears.</p> </div>	No

Field Name	Field Description	Mandatory (Yes or No)
Defer Processing Count	<p>Used to indicate whether a funding request must be processed in the deferred mode (i.e. in the background) when the number of bills in the funding request exceeds the defer processing count.</p> <div data-bbox="695 386 1149 1010" style="border: 1px solid black; padding: 5px;"> <p><b>Note:</b></p> <p>You cannot specify a negative value in the <b>Defer Processing Count</b> field.</p> <p>Deferred mode means in the background when the <b>Funding Request Periodic Monitor (C1-FNDRQ)</b> batch is invoked. You can configure the <b>Funding Request Periodic Monitor (C1-FNDRQ)</b> batch such that it is executed at regular intervals. For more information about the <b>Funding Request Periodic Monitor (C1-FNDRQ)</b> batch, refer to <i>Oracle Revenue Management and Billing Batch Guide</i>.</p> <p>If the number of bills in a funding request does not exceed the defer processing count, the system will process the funding request in real time (i.e. immediately).</p> </div>	No
Approval Required	Used to indicate whether the approval is required before creating payments for debit bills and A/P adjustments for credit bills through the funding request.	No
Approval Profile	<p>Used to indicate the approval profile using which the system should determine the debit or credit hierarchy level from where the approval is required. The system considers the debit or credit hierarchy level where the funding amount of the debit or credit bill falls within the threshold limit.</p> <div data-bbox="695 1423 1149 1507" style="border: 1px solid black; padding: 5px;"> <p><b>Note:</b> This field appears only when the <b>Approval Required</b> option is selected.</p> </div>	<p>Yes (Conditional)</p> <div data-bbox="1174 1234 1466 1381" style="border: 1px solid black; padding: 5px;"> <p><b>Note:</b> This field is required when the <b>Approval Required</b> option is selected.</p> </div>

Field Name	Field Description	Mandatory (Yes or No)
Submitter To Do Type	<p>Used to indicate that To Do entry of the specified To Do type must be created when the approver rejects the funding request or raises the request for resubmitting the funding request.</p> <p><b>Note:</b> You must specify the <b>C1-FNDSB To Do</b> type in the <b>Submitter To Do Type</b> field.</p> <p>The <b>Search</b>  icon appears corresponding to the <b>Submitter To Do Type</b> field. On clicking the <b>Search</b> icon, the <b>To Do Type Search</b> window appears.</p> <p>This field appears only when the <b>Approval Required</b> option is selected.</p>	<p>Yes (Conditional)</p> <p><b>Note:</b> This field is required when the <b>Approval Required</b> option is selected.</p>
Submitter To Do Role	<p>Used to indicate that the users with the specified To Do role must receive a To Do when the approver rejects the funding request or raises the request for resubmitting the funding request.</p> <p><b>Note:</b> This field appears only when the <b>Approval Required</b> option is selected.</p> <p>The list includes only those To Do roles which are associated to the specified submitter To Do type.</p>	<p>Yes (Conditional)</p> <p><b>Note:</b> This field is required when the <b>Approval Required</b> option is selected.</p>
Currency Conversion Adjustment Algorithm	<p>Used to indicate the currency conversion algorithm. It is used while determining the approval hierarchy for a funding request when the sum total of the debit and credit amount (i.e. which is in credit) is different from the installation options currency.</p> <p><b>Note:</b> This field appears only when the <b>Approval Required</b> option is selected.</p> <p>The <b>Search</b>  icon appears corresponding to the <b>Currency Conversion Adjustment Algorithm</b> field. On clicking the <b>Search</b> icon, the <b>Algorithm Search</b> window appears.</p>	<p>Yes (Conditional)</p> <p><b>Note:</b> This field is required when the <b>Currency Conversion Required</b> option is selected in the approval profile.</p>

Field Name	Field Description	Mandatory (Yes or No)
Currency Conversion Payment Algorithm	<p>Used to indicate the currency conversion algorithm. It is used while determining the approval hierarchy for a funding request when the sum total of the debit and credit amount (i.e. which is in debit) is different from the installation options currency.</p> <p><b>Note:</b> This field appears only when the <b>Approval Required</b> option is selected.</p> <p>The <b>Search</b>  icon appears corresponding to the <b>Currency Conversion Payment Algorithm</b> field. On clicking the <b>Search</b> icon, the <b>Algorithm Search</b> window appears.</p>	<p>Yes (Conditional)</p> <p><b>Note:</b> This field is required when the <b>Currency Conversion Required</b> option is selected in the approval profile.</p>

**Tip:** Alternatively, you can copy a funding request type by clicking the **Duplicate** button in the **Funding Request Type** zone.

5. Enter the required details in the **Main** section.
6. Define, edit, or remove characteristics from the funding request type, if required.
7. Click **Save**.

The new funding request type is defined.

### Related Topics

For more information on...	See...
<b>Funding Request Type</b> screen	<a href="#">Funding Request Type</a> on page 1322
<b>Funding Request Type List</b> zone	<a href="#">Funding Request Type List</a> on page 1322
<b>Funding Request Type</b> zone	<a href="#">Funding Request Type</a> on page 1323
How to define a characteristic for a funding request type	<a href="#">Defining a Characteristic for a Funding Request Type</a> on page 1333

## Viewing the Funding Request Type Details

### Procedure

To view the details of a funding request type:

1. Click the **Admin** link in the **Application** toolbar.  
A list appears.
2. From the **Admin** menu, select **F** and then click **Funding Request Type**.  
A sub-menu appears.
3. Click the **Search** option from the **Funding Request Type** sub-menu.  
The **Funding Request Type** screen appears.

- In the **Funding Request Type List** zone, click the **Broadcast**  icon corresponding to the funding request type whose details you want to view.

The **Funding Request Type** zone appears.

- View the details of the funding request type in the **Funding Request Type** zone.

### Related Topics

For more information on...	See...
<b>Funding Request Type</b> screen	<a href="#">Funding Request Type</a> on page 1322
<b>Funding Request Type List</b> zone	<a href="#">Funding Request Type List</a> on page 1322
<b>Funding Request Type</b> zone	<a href="#">Funding Request Type</a> on page 1323

## Funding Request (Used for Searching)

The **Funding Request** screen allows you to search for a funding request using various search criteria. It also allows you to create a funding request. It contains the following zone:

- [Search Funding Request](#) on page 1350

Through this screen, you can navigate to the following screen:

- [Funding Request \(Used for Viewing\)](#) on page 1355

## Search Funding Request

The **Search Funding Request** zone allows you to search for a funding request using various search criteria. It contains the following two sections:

- Search Criteria** - The **Search Criteria** section contains the following fields:

Field Name	Field Description	Mandatory (Yes or No)
Search By	Used to indicate whether you want to search for a funding request using the funding request or bill details. The valid values are: <ul style="list-style-type: none"> <li>Request Details</li> <li>Bill Details</li> </ul> <div style="border: 1px solid black; padding: 2px; margin-top: 5px;"><b>Note:</b> By default, the <b>Request Details</b> option is selected.</div>	Yes
Created From	Used to search funding requests which are created from a particular date onwards. <div style="border: 1px solid black; padding: 2px; margin-top: 5px;"><b>Note:</b> This field appears only when the <b>Request Details</b> option is selected from the <b>Search By</b> list.</div>	No

Field Name	Field Description	Mandatory (Yes or No)
Status	<p>Used to search funding requests with a particular status. The valid values are:</p> <ul style="list-style-type: none"> <li>• Approval In Progress</li> <li>• Deferred Processing</li> <li>• Draft</li> <li>• Processed</li> <li>• Rejected</li> </ul> <p><b>Note:</b> This field appears only when the <b>Request Details</b> option is selected from the <b>Search By</b> list.</p>	No
Created To	<p>Used to search funding requests which are created till a particular date.</p> <p><b>Note:</b> This field appears only when the <b>Request Details</b> option is selected from the <b>Search By</b> list.</p>	No
User ID	<p>Used to search funding requests which are created by a particular user.</p> <p><b>Note:</b> This field appears only when the <b>Request Details</b> option is selected from the <b>Search By</b> list.</p>	No
Funding Request Type	<p>Used to search funding requests which are created using a particular funding request type.</p> <p><b>Note:</b> This field appears only when the <b>Request Details</b> option is selected from the <b>Search By</b> list.</p>	No
Person Name	<p>Used to search funding requests which includes bills of a particular person.</p> <p><b>Note:</b> This field appears only when the <b>Request Details</b> option is selected from the <b>Search By</b> list.</p>	No
Funding Request ID	<p>Used to search a particular funding request.</p> <p><b>Note:</b> This field appears only when the <b>Request Details</b> option is selected from the <b>Search By</b> list.</p>	No
Creation Mode	<p>Used to search funding requests which are created in a particular mode. The valid values are:</p> <ul style="list-style-type: none"> <li>• Automatic</li> <li>• Manual</li> </ul> <p><b>Note:</b> This field appears only when the <b>Request Details</b> option is selected from the <b>Search By</b> list.</p>	No

Field Name	Field Description	Mandatory (Yes or No)
Bill ID	Used to search funding requests which include a particular bill.  <b>Note:</b> This field appears only when the <b>Bill Details</b> option is selected from the <b>Search By</b> list.  The <b>Search</b>  icon appears corresponding to the <b>Bill ID</b> field. On clicking the <b>Search</b> icon, the <b>Bill Search</b> window appears.	No
Bill Date From	Used to search funding requests which include bills that are created from a particular date onwards.  <b>Note:</b> This field appears only when the <b>Bill Details</b> option is selected from the <b>Search By</b> list.	No
Alternate Bill ID	Used to search funding requests which include a particular bill.  <b>Note:</b> This field appears only when the <b>Bill Details</b> option is selected from the <b>Search By</b> list.	No
Bill Date To	Used to search funding requests which include bills that are created till a particular date.  <b>Note:</b> This field appears only when the <b>Bill Details</b> option is selected from the <b>Search By</b> list.	No
Division	Used to search funding requests which includes bills of accounts which belong to a particular division.  <b>Note:</b> This field appears only when the <b>Bill Details</b> option is selected from the <b>Search By</b> list.  You can only view those divisions to which you have access in the <b>Division</b> list.	No

**Note:** You must specify at least one search criterion while searching for a funding request.

- **Search Results** - On clicking the **Search** button, the search results appear based on the specified search criteria. The **Search Results** section contains the following columns:

Column Name	Column Description
Create Date Time	Displays the date and time when the funding request is created.
Funding Request Information	Displays information about the funding request.  <b>Note:</b> It has a link. On clicking the link, the <b>Funding Request</b> screen appears where you can view the details of the respective funding request.



Column Name	Column Description
Status	Indicates the status of the funding request. The valid values are: <ul style="list-style-type: none"> <li>• Approval In Progress</li> <li>• Deferred Processing</li> <li>• Draft</li> <li>• Processed</li> <li>• Rejected</li> </ul>
Total Debit Amount	Displays the total amount of the debit bills which are added in the funding request.
Total Credit Amount	Displays the total amount of the credit bills which are added in the funding request.
Created By	Indicates the user who has created the funding request.
Creation Mode	Indicates how the funding request is created. The valid values are: <ul style="list-style-type: none"> <li>• Automatic</li> <li>• Manual</li> </ul>

**Note:** Pagination is used to display limited number of records in the **Search Results** section. You can use the navigation links, such as **Previous** and **Next** to navigate between pages.

### Related Topics

For more information on...	See...
How to search for a funding request	<a href="#">Searching for a Funding Request</a> on page 1353

## Searching for a Funding Request

### Prerequisites

To search for a funding request, you should have:

- Funding request types defined in the application

### Procedure

To search for a funding request:

1. Click the **Menu** link in the **Application** toolbar.  
A list appears.
2. From the **Main** menu, select **Financial** and then click **Funding Request**.  
A sub-menu appears.
3. Click the **Search** option from the **Funding Request** sub-menu.  
The **Funding Request** screen appears.
4. Enter the search criteria in the **Search Funding Request** zone.

**Note:** ORMB search engine supports wildcard search, where you can substitute the percentage (%) symbol as a stand in for any word or letter in a search criteria. You can use the ‘%’ wildcard character in all input fields except the date and ID fields. The ‘%’ wildcard character is suffixed automatically at the end of the partial search criteria. Therefore, you may or may not specify the wildcard character at the end of the partial search criteria. However, you have to prefix the wildcard character manually wherever required.

### 5. Click **Search**.

A list of funding requests that meet the search criteria appears in the **Search Results** section.

#### Related Topics

For more information on...	See...
<b>Funding Request</b> screen	<a href="#">Funding Request (Used for Searching)</a> on page 1350
<b>Search Funding Request</b> zone	<a href="#">Search Funding Request</a> on page 1350

## Creating a Funding Request

### Prerequisites

To create a funding request, you should have:

- Funding request types defined in the application

### Procedure

To create a funding request:

1. Click the **Menu** link in the **Application** toolbar.  
A list appears.
2. From the **Main** menu, select **Financial** and then click **Funding Request**.  
A sub-menu appears.
3. Click the **Add** option from the **Funding Request** sub-menu.

The **Add Funding Request** screen appears. It contains the following field:

Field Name	Field Description	Mandatory (Yes or No)
Funding Request Type	Used to indicate the funding request type using which you want to create the funding request.	Yes

**Tip:** Alternatively, you can access this screen by clicking the **Add** button in the **Page Title** area of the **Funding Request** screen.

4. Select the required funding request type from the respective field.
5. Click **OK**.

The funding request is created in the **Draft** status.

#### Related Topics

For more information on...	See...
<b>Funding Request</b> screen	<a href="#">Funding Request (Used for Searching)</a> on page 1350
How to add a debit or credit bill to the funding request	<a href="#">Adding a Debit or Credit Bill to a Funding Request</a> on page 1368
How to define a characteristic for a funding request	<a href="#">Defining a Characteristic for a Funding Request</a> on page 1373

## Viewing the Funding Request Details

### Procedure

To view the details of a funding request:

1. Search for the funding request in the **Funding Request** screen.
2. In the **Search Results** section, click the link in the **Funding Request Information** column corresponding to the funding request whose details you want to view.

The **Funding Request** screen appears.

3. Ensure that the **Main** tab is selected.
4. View the details of the funding request in the **Funding Request** zone.
5. View the credit and/or debit bills added in the funding request in the **Selected Bills** zone.

### Related Topics

For more information on...	See...
How to search for a funding request	<a href="#">Searching for a Funding Request</a> on page 1353
<b>Funding Request</b> screen	<a href="#">Funding Request (Used for Viewing)</a> on page 1355
<b>Funding Request</b> zone	<a href="#">Funding Request</a> on page 1356
<b>Selected Bills</b> zone	<a href="#">Selected Bills</a> on page 1364

## Funding Request (Used for Viewing)

---

The **Funding Request** screen allows you to:

- Edit the details of a funding request
- Delete or cancel a funding request
- View the details of a funding request
- Submit a funding request for processing
- Approve or reject a funding request
- Request the submitter to resubmit a funding request for approval
- Withdraw a funding request
- View the log of a funding request
- Add a log entry for a funding request

It consists of the following tabs:

- [Funding Request - Main](#) on page 1355
- [Funding Request - Bills](#) on page 1363
- [Funding Request - Log](#) on page 1367

### Funding Request - Main

The **Main** tab displays information about the funding request. It contains the following zones:

- [Funding Request](#) on page 1356
- [Search Bill](#) on page 1359

## Funding Request

The **Funding Request** zone displays the details of the funding request. It contains the following sections:

- **Main** - Displays basic information about the funding request. It contains the following fields:

Field Name	Field Description
Funding Request Information	Displays information about the funding request.
Funding Request Type	Indicates the funding request type using which the funding request is created.  <b>Note:</b> It has a link. On clicking the link, the <b>Funding Request Type</b> screen appears where you can view the details of the respective funding request type.
Status	Indicates the status of the funding request. The valid values are: <ul style="list-style-type: none"> <li>• Approval In Progress</li> <li>• Deferred Processing</li> <li>• Draft</li> <li>• Processed</li> <li>• Rejected</li> </ul>
Status Reason	Indicates the reason why the funding request is rejected.  <b>Note:</b> This field appears only when the funding request is in the <b>Rejected</b> status. It has a link. On clicking the link, the <b>Status Reason</b> screen appears where you can view the details of the respective status reason.
Funding Adjustment Type	Indicates the adjustment type using which the A/P adjustment is created against a credit bill.  <b>Note:</b> It has a link. On clicking the link, the <b>Adjustment Type</b> screen appears where you can view the details of the respective adjustment type.
Garnishment Adjustment Type	Indicates the adjustment type using which the garnishment adjustment is created when the amount from the credit bill is transferred to the garnishment contract of the account.  <b>Note:</b> It has a link. On clicking the link, the <b>Adjustment Type</b> screen appears where you can view the details of the respective adjustment type.
Comments	Displays additional information entered while rejecting the funding request.  <b>Note:</b> This field appears only when the funding request is in the <b>Rejected</b> status.

Field Name	Field Description
Creation Mode	Indicates whether the funding request is created automatically or manually. The valid values are: <ul style="list-style-type: none"> <li>Automatic</li> <li>Manual</li> </ul>

- **Statistics** - Displays analytical information about the funding request. It contains the following fields:

Field Name	Field Description
Total Records	Displays the total number of debit or credit bills which are added in the funding request.
Total Records Processed	Displays the total number of debit or credit bills for which payments or adjustments are successfully created in the system.
Total Records Excluded	Displays the total number of debit or credit bills which are excluded from the automatic funding request.
Total Records In Error	Displays the total number of debit or credit bills for which payments or adjustments was not successfully created in the system.
Total Payment Incoming Events Created	Displays the total number of payment events created against the debit bills in the funding request.
Total Adjustments Created	Displays the total number of adjustments created against the credit bills in the funding request.
Total Credit Funding Amount	Displays the sum of funding amount and garnishment amount of all bills whose funding amount is in credit. The sum total is calculated in the funding amount currency which is specified in the funding request type. <div style="border: 1px solid black; padding: 5px; margin-top: 10px;"> <p><b>Note:</b> If the credit bill's currency is different from the funding amount currency, the system does the currency conversion before calculating the sum total. The system uses the currency conversion algorithm attached to the <b>Currency Conversion For Adjustments</b> algorithm spot of the account's division.</p> </div>
Total Debit Funding Amount	Displays the sum of funding amount of all bills whose funding amount is in debit. The sum total is calculated in the funding amount currency which is specified in the funding request type. <div style="border: 1px solid black; padding: 5px; margin-top: 10px;"> <p><b>Note:</b> If the debit bill's currency is different from the funding amount currency, the system does the currency conversion before calculating the sum total. The system uses the currency conversion algorithm attached to the <b>Currency Conversion For Payments</b> algorithm spot of the account's division.</p> </div>

- **Record Actions** - This section contains the following buttons:

Button Name	Button Description
Edit	Used to edit the details of the funding request. <div style="border: 1px solid black; padding: 5px; margin-top: 10px;"> <p><b>Note:</b> The <b>Edit</b> button appears only when the funding request is in the <b>Draft</b> status.</p> </div>

Button Name	Button Description
Delete	Used to delete the funding request. <b>Note:</b> The <b>Delete</b> button appears only when the funding request is in the <b>Draft</b> status.
Submit	Used to submit the funding request. <b>Note:</b> The <b>Submit</b> button appears only when the funding request is in the <b>Draft</b> status.
Cancel	Used to cancel the funding request. <b>Note:</b> The <b>Cancel</b> button appears only when the funding request is in the <b>Draft</b> status.
Approve	Used to approve the funding request. <b>Note:</b> The <b>Approve</b> button appears only when: <ul style="list-style-type: none"> <li>The funding request is in the <b>Approval In Progress</b> status.</li> <li>A user with the approval To Do role is reviewing the funding request.</li> </ul>
Reject	Used to reject the funding request. <b>Note:</b> The <b>Reject</b> button appears only when: <ul style="list-style-type: none"> <li>The funding request is in the <b>Approval In Progress</b> status.</li> <li>A user with the approval To Do role is reviewing the funding request.</li> </ul>
Re Submit	Used to request for resubmitting the funding request. <b>Note:</b> The <b>Re Submit</b> button appears only when: <ul style="list-style-type: none"> <li>The funding request is in the <b>Approval In Progress</b> status.</li> <li>A user with the approval To Do role is reviewing the funding request.</li> </ul>
Withdraw	Used to withdraw the funding request. <b>Note:</b> The <b>Withdraw</b> button appears only when: <ul style="list-style-type: none"> <li>The funding request is in the <b>Approval In Progress</b> status.</li> <li>A user with the submitter To Do role is viewing the funding request.</li> </ul>

- **Record Information** - This section contains the following fields:

Field Name	Field Description
Business Object	Indicates the business object using which the funding request is created. In addition, a context menu appears corresponding to this field which helps in navigating to other screens in the application.  <b>Note:</b> It has a link. On clicking the link, the <b>Business Object</b> screen appears where you can view the details of the respective business object.
Status Date/Time	Displays the date and time when the funding request status is updated
Create Date/Time	Displays the date and time when the funding request is created.

- **Characteristics** - Lists the characteristics defined for the funding request. It contains the following columns:

Column Name	Column Description
Effective Date	Displays the date from when the characteristic is effective for the funding request.
Characteristic Type	Indicates the characteristic type.
Characteristic Value	Displays the value of the characteristic type.

### **Related Topics**

For more information on...	See...
How to edit a funding request	<a href="#">Editing a Funding Request</a> on page 1372
How to delete a funding request	<a href="#">Deleting a Funding Request</a> on page 1374
How to submit a funding request	<a href="#">Submitting a Funding Request</a> on page 1376
How to cancel a funding request	<a href="#">Cancelling a Funding Request</a> on page 1375
How to approve a funding request	<a href="#">Approving a Funding Request</a> on page 1378
How to reject a funding request	<a href="#">Rejecting a Funding Request</a> on page 1380
How to request for resubmitting a funding request	<a href="#">Requesting to Resubmit a Funding Request</a> on page 1382
How to withdraw a funding request	<a href="#">Withdrawing a Funding Request</a> on page 1383

### **Search Bill**

The **Search Bill** zone allows you to search for a bill using various search criteria. It appears only when the funding request is in the **Draft** status and the creation mode is set to **Manual**. It contains the following two sections:

- **Search Criteria** - The **Search Criteria** section contains the following fields:

Field Name	Field Description	Mandatory (Yes or No)
Search By	<p>Used to indicate whether you want to search for a bill using the person, account, or bill details. The valid values are:</p> <ul style="list-style-type: none"> <li>• Bill Details</li> <li>• Account Details</li> <li>• Person Details</li> </ul> <p><b>Note:</b> By default, the <b>Bill Details</b> option is selected.</p>	Yes
Bill ID	<p>Used to search a particular bill.</p> <p><b>Note:</b> This field appears only when the <b>Bill Details</b> option is selected from the <b>Search By</b> list.</p> <p>The <b>Search</b>  icon appears corresponding to the <b>Bill ID</b> field. On clicking the <b>Search</b> icon, the <b>Bill Search</b> window appears.</p>	No
Bill Date From	<p>Used to search bills which are created from a particular date onwards.</p> <p><b>Note:</b> This field appears only when the <b>Bill Details</b> option is selected from the <b>Search By</b> list.</p> <p>By default, the current date appears in this field.</p>	Yes
Alternate Bill ID	<p>Used to search a particular bill.</p> <p><b>Note:</b> This field appears only when the <b>Bill Details</b> option is selected from the <b>Search By</b> list.</p>	No
Bill Date To	<p>Used to search bills which are created till a particular date.</p> <p><b>Note:</b> This field appears only when the <b>Bill Details</b> option is selected from the <b>Search By</b> list.</p> <p>By default, the current date appears in this field.</p>	Yes
Bill Balance	<p>Used to indicate whether you want to search bills with debit or credit balance. The valid values are:</p> <ul style="list-style-type: none"> <li>• Credit</li> <li>• Debit</li> </ul> <p><b>Note:</b> This field appears only when the <b>Bill Details</b> option is selected from the <b>Search By</b> list.</p>	No



Field Name	Field Description	Mandatory (Yes or No)
Bill Due Date From	<p>Used to search bills which are due from a particular date onwards.</p> <p><b>Note:</b> This field appears only when the <b>Bill Details</b> option is selected from the <b>Search By</b> list.</p>	No
Division	<p>Used to search bills of accounts which belong to a particular division.</p> <p><b>Note:</b> You can only view those divisions to which you have access in the <b>Division</b> list. This field appears only when the <b>Bill Details</b> option is selected from the <b>Search By</b> list.</p>	No
Bill Due Date To	<p>Used to search bills which are due till a particular date.</p> <p><b>Note:</b> This field appears only when the <b>Bill Details</b> option is selected from the <b>Search By</b> list.</p>	No
Account ID	<p>Used to search bills of a particular account.</p> <p><b>Note:</b> This field appears only when the <b>Account Details</b> option is selected from the <b>Search By</b> list.</p>	<p>Yes (Conditional)</p> <p><b>Note:</b> This field is required when the <b>Account Details</b> option is selected from the <b>Search By</b> list.</p>
Person ID	<p>Used to search bills which belong to a particular person.</p> <p><b>Note:</b> This field appears only when the <b>Person Details</b> option is selected from the <b>Search By</b> list.</p>	<p>Yes (Conditional)</p> <p><b>Note:</b> This field is required when:</p> <ul style="list-style-type: none"> <li>• The <b>Person Details</b> option is selected from the <b>Search By</b> list.</li> <li>• The person name is not specified in the search criteria.</li> </ul>
Person Name	<p>Used to search bills which are created for accounts of a particular person.</p> <p><b>Note:</b> This field appears only when the <b>Person Details</b> option is selected from the <b>Search By</b> list.</p>	<p>Yes (Conditional)</p> <p><b>Note:</b> This field is required when:</p> <ul style="list-style-type: none"> <li>• The <b>Person Details</b> option is selected from the <b>Search By</b> list.</li> <li>• The person ID is not specified in the search criteria.</li> </ul>

Field Name	Field Description	Mandatory (Yes or No)
Country	Used to search bills of persons who reside in a particular country.  <b>Note:</b> This field appears only when the <b>Person Details</b> option is selected from the <b>Search By</b> list.	No

**Note:** You must specify at least one search criterion while searching for a bill.

- **Search Results** - On clicking the **Search** button, the search results appear based on the specified search criteria. The **Search Results** section contains the following columns:

Column Name	Column Description						
Bill Information	Displays additional information about the bill. In addition, this column has a context menu which helps in navigating to other screens in the application.  <b>Note:</b> It has a link. On clicking the link, the <b>Bill</b> screen appears where you can view the details of the respective bill.						
Due Date	Displays the date when the bill is due for payment.						
Outstanding Amount	Displays the unpaid amount of the bill.						
Hold Amount	Displays the amount of the bill which is kept on hold through a hold request.						
Funding Amount	Displays the bill amount which can be used for the funding process. It is calculated in the following manner: <table border="1" data-bbox="573 1052 1463 1360"> <thead> <tr> <th>Bill Type</th> <th>Funding Amount for the Bill</th> </tr> </thead> <tbody> <tr> <td>Debit Bill</td> <td>Outstanding Bill Amount – Hold Amount (set on the bill in a hold request) – Offset Amount (set on the bill in an offset request)</td> </tr> <tr> <td>Credit Bill</td> <td>Outstanding Bill Amount – Hold Amount (set on the bill in a hold request) – Offset Amount (set on the bill in an offset request) – Garnishment Amount (set on the bill in a funding request)</td> </tr> </tbody> </table>	Bill Type	Funding Amount for the Bill	Debit Bill	Outstanding Bill Amount – Hold Amount (set on the bill in a hold request) – Offset Amount (set on the bill in an offset request)	Credit Bill	Outstanding Bill Amount – Hold Amount (set on the bill in a hold request) – Offset Amount (set on the bill in an offset request) – Garnishment Amount (set on the bill in a funding request)
Bill Type	Funding Amount for the Bill						
Debit Bill	Outstanding Bill Amount – Hold Amount (set on the bill in a hold request) – Offset Amount (set on the bill in an offset request)						
Credit Bill	Outstanding Bill Amount – Hold Amount (set on the bill in a hold request) – Offset Amount (set on the bill in an offset request) – Garnishment Amount (set on the bill in a funding request)						
Person Name	Indicates the person to whom the bill belongs. In addition, this column has a context menu which helps in navigating to other screens in the application.  <b>Note:</b> It has a link. On clicking the link, the <b>Person</b> screen appears where you can view the details of the respective person.						
Bill ID	Displays the bill ID.						
Defer Auto Pay	Indicates whether the <b>Defer Auto Pay</b> option is selected on the customer class of the account for which the bill is created. The valid values are: <ul style="list-style-type: none"> <li>• N</li> <li>• Y</li> </ul>						

**Note:** Pagination is used to display limited number of records in the **Search Results** section. You can use the navigation links, such as **Previous** and **Next** to navigate between pages.

In addition, this section contains the following button:

Button Name	Button Description
Add	Used to add a bill to the funding request.

A check box appears corresponding to each bill. On selecting the check box, you can add the bill to the funding request. You can also select multiple bills at the same time. In addition, you can select the check box corresponding to the column header. This allows you to add all bills listed in the respective page to the funding request.

### Related Topics

For more information on...	See...
How to add a debit or credit bill to a funding request	<a href="#">Adding a Debit or Credit Bill to a Funding Request</a> on page 1368

## Funding Request - Bills

The **Bills** tab lists the bills which are added in the funding request. It contains the following zones:

- [Currency Statistics](#) on page 1363
- [Selected Bills](#) on page 1364
- [Funding Payment Details](#) on page 1367

**Note:** This zone appears only when the funding request is in the **Processed** status and the funding amount of the bill is in debit.

- [Funding Adjustments](#) on page 1367

**Note:** This zone appears only when the funding request is in the **Processed** status and the funding amount of the bill is in credit.

### Currency Statistics



A funding request might include bills in different currencies. The **Currency Statistics** zone lists the sum total of various amount of bills which are created in the same currency. It contains the following columns:

Column Name	Column Description
Currency Code	Indicates the currency in which the sum total is calculated. <b>Note:</b> Here, the system lists those currencies in which the bills added to the funding request are created.
Total Outstanding Amount	Displays the sum of outstanding amount of all bills which are created in the respective currency.
Total Hold Amount	Displays the sum of hold amount of all bills which are created in the respective currency.
Total Garnishment Amount	Displays the sum of garnishment amount of all bills which are created in the respective currency.
Total Debit Funding Amount	Displays the sum of funding amount (which is in debit) of all bills which are created in the respective currency.
Total Credit Funding Amount	Displays the sum of funding amount (which is in credit) of all bills which are created in the respective currency.

## Selected Bills

The **Selected Bills** zone lists the debit and credit bills which are added to the funding request. It contains the following columns:

Column Name	Column Description						
Bill Date	Displays the date when the bill is created.						
Person Identifier	Displays the primary identifier of the person for whom the bill is created.						
Person Country	Indicates the country where the person is located.						
Invoice Account Identifier	Displays the primary identifier of the account for which the bill is created.						
Funding Amount	<p>Displays the bill amount which can be used for the funding process. It is calculated in the following manner:</p> <table border="1"> <thead> <tr> <th>Bill Type</th> <th>Funding Amount for the Bill</th> </tr> </thead> <tbody> <tr> <td>Debit Bill</td> <td>Outstanding Bill Amount – Hold Amount (set on the bill in a hold request) – Offset Amount (set on the bill in an offset request)</td> </tr> <tr> <td>Credit Bill</td> <td>Outstanding Bill Amount – Hold Amount (set on the bill in a hold request) – Offset Amount (set on the bill in an offset request) – Garnishment Amount (set on the bill in a funding request)</td> </tr> </tbody> </table> <p><b>Note:</b> The funding amount is calculated in the bill's currency.</p>	Bill Type	Funding Amount for the Bill	Debit Bill	Outstanding Bill Amount – Hold Amount (set on the bill in a hold request) – Offset Amount (set on the bill in an offset request)	Credit Bill	Outstanding Bill Amount – Hold Amount (set on the bill in a hold request) – Offset Amount (set on the bill in an offset request) – Garnishment Amount (set on the bill in a funding request)
Bill Type	Funding Amount for the Bill						
Debit Bill	Outstanding Bill Amount – Hold Amount (set on the bill in a hold request) – Offset Amount (set on the bill in an offset request)						
Credit Bill	Outstanding Bill Amount – Hold Amount (set on the bill in a hold request) – Offset Amount (set on the bill in an offset request) – Garnishment Amount (set on the bill in a funding request)						
Currency Code	Indicates the currency in which the funding amount is calculated.						
Hold Amount	Displays the amount of the bill which is kept on hold through a hold request.						
Offset Amount	Displays the amount of the bill which is offset against another bill through an offset request.						
Garnishment Amount	Displays the amount of the credit bill which is transferred to the garnishment contracts of the account through the funding request.						
Original Outstanding Amount	Displays the original outstanding amount when the bill was added in the funding request.						
Bill ID	<p>Displays the bill ID.</p> <p><b>Note:</b> It has a link. On clicking the link, the <b>Bill</b> screen appears where you can view the details of the respective bill.</p>						
Open Bills	<p>Indicates whether there are any unpaid bills of the person. The valid values are:</p> <ul style="list-style-type: none"> <li>• Y</li> <li>• N</li> </ul>						

Column Name	Column Description
Garnishment Contract	<p>Indicates whether the garnishment contract exists for the account. The valid values are:</p> <ul style="list-style-type: none"> <li>• Y</li> <li>• N</li> </ul> <div style="border: 1px solid black; padding: 5px; margin-top: 10px;"> <p><b>Note:</b></p> <p>This column appears only when the funding request is in the <b>Draft</b> status.</p> <p>The data appears in this column only when a credit bill is added to the funding request.</p> <p>It has a link. On clicking the link, the <b>Edit Garnishment Details</b> screen appears where you can transfer the funding amount from the credit bill to one or more garnishment contracts of the account.</p> </div>
Garnishment	<p>On clicking the <b>View</b>  icon, the <b>View Garnishment Details</b> screen appears where you can view the funding amount transferred to the different garnishment contracts of the account.</p> <div style="border: 1px solid black; padding: 5px; margin-top: 10px;"> <p><b>Note:</b></p> <p>This column does not appear when the funding request is in the <b>Draft</b> status.</p> <p>The <b>View</b>  icon appears in this column only when the funding request is in the <b>Processed</b> status.</p> </div>
Record Status	<p>Indicates the status of the bill record in the funding request. The valid values are:</p> <ul style="list-style-type: none"> <li>• Excluded</li> <li>• Invalid</li> <li>• Masked</li> <li>• Pending</li> <li>• Processed</li> <li>• Valid</li> <li>• Error</li> </ul>
Threshold Range	<p>Indicates the threshold range for a bill which is calculated based on the number of payments made for the bill in the specified period.</p>
Person Name	<p>Indicates the person whose bill is added in the funding request.</p>
Bill Information	<p>Displays the information about the bill.</p>
Split Banking	<p>Indicates whether the split automatic payment feature is used for the account. The valid values are:</p> <ul style="list-style-type: none"> <li>• Y</li> <li>• N</li> </ul>
Funding Currency Amount	<p>Displays the funding amount which is converted in the funding currency defined on the account.</p>

**Note:** Pagination is used to display limited number of records in the **Search Results** section. You can use the navigation links, such as **Previous** and **Next** to navigate between pages.

In addition, this section contains the following button:

Button Name	Button Description
Delete	Used to delete a bill from the funding request. <b>Note:</b> The <b>Delete</b> button appears only when the funding request is created manually and it is in the <b>Draft</b> status.
Edit	Used to exclude a debit or credit bill from the funding request. <b>Note:</b> The <b>Edit</b> button appears only when the funding request is created automatically and it is in the <b>Draft</b> status.
Hold	Used to create a hold request for one or more bills. However, you cannot select more than 20 bills. On activating or releasing a hold request, the funding amount is automatically updated in the funding request. <b>Note:</b> The <b>Hold</b> button appears only when the funding request is in the <b>Draft</b> status.
Offset	Used to create an offset request for a bill. On processing or unapplying an offset request, the funding amount is automatically updated in the funding request. <b>Note:</b> The <b>Offset</b> button appears only when the funding request is in the <b>Draft</b> status.

A check box appears corresponding to each bill when the funding request is in the **Draft** status. On selecting the check box, you can delete the bill from the funding request. You can also select multiple bills at the same time. In addition, you can select the check box corresponding to the column header. This allows you to delete all bills listed in the respective page from the funding request.

On clicking the **Broadcast**  icon corresponding to a debit or credit bill, the **Funding Payment Details** or **Funding Adjustments** zone appears, respectively.

**Note:** The **Broadcast** icon does not appear when the funding request is in the **Draft** status.

You can filter the list using various search criteria (such as, **Bill ID**, **Alternate Bill ID**, **Record Status**, **Bill Balance**, **Funding Amount From**, **Person ID**, **Funding Amount To**, **Currency**, **Funding Amount Threshold Range**, and **Country**) available in the **Filter** area. By default, the **Filter** area is hidden. You can view the **Filter** area by clicking the **Filters**  icon in the upper right corner of this zone.

#### Related Topics

For more information on...	See...
How to delete a debit or credit bill from a funding request	<a href="#">Deleting a Debit or Credit Bill from a Funding Request</a> on page 1369
<b>Funding Payment Details</b> zone	<a href="#">Funding Payment Details</a> on page 1367
<b>Funding Adjustments</b> zone	<a href="#">Funding Adjustments</a> on page 1367
How to transfer the funding amount of a credit bill to a garnishment contract	<a href="#">Transferring the Funding Amount of a Credit Bill to a Garnishment Contract</a> on page 1384

For more information on...	See...
How to view the garnishment details of a credit bill	<a href="#">Viewing the Garnishment Details of a Credit Bill</a> on page 1385
How to exclude a debit or credit bill from a funding request	<a href="#">Excluding a Bill from a Funding Request</a> on page 1370

### Funding Payment Details

The **Funding Payment Details** zone lists the payment events which are created for a debit bill through the funding request. It appears only when the funding request is in the **Processed** status. It contains the following columns:

Column Name	Column Description
Payment Event Information	Displays information about the payment event. <b>Note:</b> It has a link. On clicking the link, the <b>Payment Event</b> screen appears where you can view the details of the respective payment event.
Payment Amount	Displays the amount for which automatic payment is created.

**Note:** Pagination is used to display limited number of records in the **Search Results** section. You can use the navigation links, such as **Previous** and **Next** to navigate between pages.

### Funding Adjustments

The **Funding Adjustments** zone lists the funding and garnishment adjustments which are created for a credit bill through the funding request. It appears only when the funding request is in the **Processed** status. It contains the following columns:

Column Name	Column Description
Adjustment Information	Displays information about the funding or garnishment adjustment. <b>Note:</b> It has a link. On clicking the link, the <b>Adjustment</b> screen appears where you can view the details of the respective adjustment.
Adjustment Amount	Displays the adjustment amount.

**Note:** Pagination is used to display limited number of records in the **Search Results** section. You can use the navigation links, such as **Previous** and **Next** to navigate between pages.

### Funding Request - Log

The **Log** tab contains the following zone:

- [Funding Request Log](#) on page 1367

### Funding Request Log

The **Funding Request Log** zone lists the complete trail of actions performed on the funding request. It contains the following columns:

Column Name	Column Description
Date/Time	Displays the date and time when the action was performed on the funding request.
Details	Displays the details of the action performed on the funding request.

Column Name	Column Description
User	Indicates the user who has performed the action on the funding request.
Log Type	Indicates the type of log.
Related Object	Indicates the object or entity which is created when the action is performed on the funding request.  <b>Note:</b> At present, no data appears in this column. The implementation team can build the custom logic to meet the business requirements.
Status Reason	Indicates the reason why the funding request was rejected by the approver.  <b>Note:</b> The data appears in this column only when the funding request is in the <b>Rejected</b> status.

**Note:** You can manually add a log entry for the funding request by clicking the **Add Log Entry** link in the upper right corner of the **Funding Request Log** zone.

### Related Topics

For more information on...	See...
How to view the log of a funding request	<a href="#">Viewing the Log of a Funding Request</a> on page 1387
How to add a log entry for a funding request	<a href="#">Adding a Log Entry for a Funding Request</a> on page 1388

## Adding a Debit or Credit Bill to a Funding Request

In a funding request, you can only add the debit or credit bills of the accounts for which the **Defer Auto Pay** option is selected on the respective customer class.

### Procedure

To add a debit or credit bill to a funding request:

1. Search for the funding request in the **Funding Request** screen.
2. In the **Search Results** section, click the link in the **Funding Request Information** column corresponding to the funding request whose details you want to edit.

The **Funding Request** screen appears.

3. Ensure that the **Main** tab is selected.
4. Enter the search criteria in the **Search Bill** zone.

#### **Note:**

The **Search Bill** zone appears only when the funding request is in the **Draft** status.

ORMB search engine supports wildcard search, where you can substitute the percentage (%) symbol as a stand in for any word or letter in a search criteria. You can use the ‘%’ wildcard character in all input fields except the date and ID fields. The ‘%’ wildcard character is suffixed automatically at the end of the partial search criteria. Therefore, you may or may not specify the wildcard character at the end of the partial search criteria. However, you have to prefix the wildcard character manually wherever required.

5. Click **Search**.



A list of bills that meet the search criteria appears in the **Search Results** section.

6. Select the check box corresponding to a bill that you want to add to the funding request.
7. Click the **Add** button in the **Search Bill** zone.

A message appears indicating that the bill is added to the funding request.

**Note:** You can only add a debit or credit bill of an account for which the **Defer Auto Pay** option is selected on the respective customer class.

8. Click **OK**.

The bill is added to the funding request. The status of the bill record in the funding request is set to **Pending**.

### **Related Topics**

<b>For more information on...</b>	<b>See...</b>
How to search for a funding request	<a href="#">Searching for a Funding Request</a> on page 1353
<b>Funding Request</b> screen	<a href="#">Funding Request (Used for Viewing)</a> on page 1355
<b>Search Bill</b> zone	<a href="#">Search Bill</a> on page 1359
How to create a funding request	<a href="#">Creating a Funding Request</a> on page 1354

## **Deleting a Debit or Credit Bill from a Funding Request**

### **Procedure**

To delete a debit or credit bill from a funding request:

1. Search for the funding request in the **Funding Request** screen.
2. In the **Search Results** section, click the link in the **Funding Request Information** column corresponding to the funding request whose details you want to edit.

The **Funding Request** screen appears.

3. Click the **Bills** tab.

The **Bills** tab appears.

4. In the **Selected Bills** zone, select the check box corresponding to a bill that you want to delete from the funding request.

5. Click the **Delete** button in the **Selected Bills** zone.

A message appears confirming whether you want to delete the bill from the funding request.

**Note:** The **Delete** button appears only when the funding request is in the **Draft** status.

6. Click **OK**.

The debit or credit bill is deleted from the funding request.

### **Related Topics**

<b>For more information on...</b>	<b>See...</b>
How to search for a funding request	<a href="#">Searching for a Funding Request</a> on page 1353
<b>Funding Request</b> screen	<a href="#">Funding Request (Used for Viewing)</a> on page 1355

<b>For more information on...</b>	<b>See...</b>
<b>Selected Bills</b> zone	<a href="#">Selected Bills</a> on page 1364

## Excluding a Bill from a Funding Request

If the funding request is manually created through the user interface, you add or delete bills from the funding request when it is in the **Draft** status. However, if the funding request is automatically created through a custom logic, the system allows you to exclude the required bills from the funding request when it is in the **Draft** status. In such case, the status of the record in the funding request is changed to **Excluded**. The excluded bills can then be included in some other funding request.

### Prerequisites

To exclude a bill from a funding request, you should have:

- Values defined for the **CAN\_RSN\_CD\_FLG** lookup field

### Procedure

To exclude a bill from a funding request:

1. Search for the funding request in the **Funding Request** screen.
2. In the **Search Results** section, click the link in the **Funding Request Information** column corresponding to the funding request whose details you want to edit.

The **Funding Request** screen appears.

3. Click the **Bills** tab.

The **Bills** tab appears.

4. In the **Selected Bills** zone, select the check box corresponding to a bill that you want to exclude from the funding request.
5. Click the **Edit** button in the **Selected Bills** zone.

The **Edit Funding Request Details** screen appears. It contains the following field:

Field Name	Field Description
Funding Request Information	Displays the information about the funding request.

In addition, this screen contains the following fields in a grid:

Field Name	Field Description	Mandatory (Yes or No)
Bill Information	Displays the information about the bill.	Not applicable
Garnishment Amount	Displays the funding amount which is transferred to the garnishment contracts of the account.	Not applicable

Field Name	Field Description	Mandatory (Yes or No)						
Funding Amount	<p>Displays the bill amount which can be used for the funding process. It is calculated in the following manner:</p> <table border="1"> <thead> <tr> <th>Bill Type</th> <th>Funding Amount for the Bill</th> </tr> </thead> <tbody> <tr> <td>Debit Bill</td> <td>Outstanding Bill Amount – Hold Amount (set on the bill in a hold request) – Offset Amount (set on the bill in an offset request)</td> </tr> <tr> <td>Credit Bill</td> <td>Outstanding Bill Amount – Hold Amount (set on the bill in a hold request) – Offset Amount (set on the bill in an offset request) – Garnishment Amount (set on the bill in a funding request)</td> </tr> </tbody> </table>	Bill Type	Funding Amount for the Bill	Debit Bill	Outstanding Bill Amount – Hold Amount (set on the bill in a hold request) – Offset Amount (set on the bill in an offset request)	Credit Bill	Outstanding Bill Amount – Hold Amount (set on the bill in a hold request) – Offset Amount (set on the bill in an offset request) – Garnishment Amount (set on the bill in a funding request)	Not applicable
Bill Type	Funding Amount for the Bill							
Debit Bill	Outstanding Bill Amount – Hold Amount (set on the bill in a hold request) – Offset Amount (set on the bill in an offset request)							
Credit Bill	Outstanding Bill Amount – Hold Amount (set on the bill in a hold request) – Offset Amount (set on the bill in an offset request) – Garnishment Amount (set on the bill in a funding request)							
Status	<p>Used to indicate the status of the record in the funding request. The valid values are:</p> <ul style="list-style-type: none"> <li>• Excluded</li> <li>• Invalid</li> <li>• Masked</li> <li>• Pending</li> <li>• Processed</li> <li>• Valid</li> </ul>	Yes						
Cancel Reason	<p>Used to indicate the reason why you want to exclude the bill from the funding request.</p> <p><b>Note:</b> The list includes only those values which are defined in the <b>CAN_RSN_CD_FLG</b> lookup field.</p>	<p>Yes (Conditional)</p> <p><b>Note:</b> This field is required when you want to exclude the bill from the funding request.</p>						

**Note:** The **Edit** button appears only when the creation mode of the funding request is set to **Automatic** and the funding request is in the **Draft** status.

6. Select the **Excluded** option from the **Status** field.
7. Select the required cancel reason from the respective field.
8. Click **Save**.

The bill is excluded from the funding request. The status of the bill record in the funding request is set to **Excluded**.

#### **Related Topics**

For more information on...	See...
How to search for a funding request	<a href="#">Searching for a Funding Request</a> on page 1353
<b>Funding Request</b> screen	<a href="#">Funding Request (Used for Viewing)</a> on page 1355

<b>For more information on...</b>	<b>See...</b>
<b>Selected Bills</b> zone	<a href="#">Selected Bills</a> on page 1364

## Editing a Funding Request

### Prerequisites

To edit a funding request, you should have:

- Funding adjustment types defined in the application (where the **A/P Request Type Code** field is set to **REFUND**)
- Garnishment adjustment types defined in the application (where the **A/P Request Type Code** field is not set to **REFUND**)

### Procedure

To edit a funding request:

1. Search for the funding request in the **Funding Request** screen.
2. In the **Search Results** section, click the link in the **Funding Request Information** column corresponding to the funding request whose details you want to edit.

The **Funding Request** screen appears.

3. Click the **Edit** button in the **Funding Request** zone.

The **Edit Funding Request** screen appears. It contains the following sections:

- **Main** - Used to specify basic details about the funding request.
- **Characteristics** - Used to define a characteristic for the funding request.

The **Main** section contains the following fields:

Field Name	Field Description	Mandatory (Yes or No)
Funding Request Information	Displays information about the funding request.	Not applicable
Funding Adjustment Type	<p>Used to indicate the adjustment type using which the A/P adjustment should be created against a credit bill.</p> <p><b>Note:</b></p> <p>The <b>Search</b>  icon appears corresponding to the <b>Funding Adjustment Type</b> field. On clicking the <b>Search</b> icon, the <b>Adjustment Type Search</b> window appears.</p> <p>In the <b>Funding Adjustment Type</b> field, you can only specify an adjustment type where the <b>A/P Request Type Code</b> field is set to <b>REFUND</b>.</p>	<p>Yes (Conditional)</p> <p><b>Note:</b> This field is required while creating an A/P adjustment against a credit bill.</p>

Field Name	Field Description	Mandatory (Yes or No)
Garnishment Adjustment Type	<p>Used to indicate the adjustment type using which the garnishment adjustment should be created when the amount from the credit bill is transferred to the garnishment contract of the account.</p> <p><b>Note:</b></p> <p>The <b>Search</b>  icon appears corresponding to the <b>Garnishment Adjustment Type</b> field. On clicking the <b>Search</b> icon, the <b>Adjustment Type Search</b> window appears.</p> <p>In the <b>Garnishment Adjustment Type</b> field, you can only specify an adjustment type where the <b>A/P Request Type Code</b> field is not set to <b>REFUND</b>.</p>	<p>Yes (Conditional)</p> <p><b>Note:</b> This field is required while creating garnishment adjustments for a credit bill.</p>
Comments	Used to specify additional information about the funding request.	No

**Note:** The **Edit** button appears only when the funding request is in the **Draft** status.

4. Modify the details of the funding request, if required.
5. Define, edit, or remove characteristics from the funding request, if required.
6. Click **Save**.

The changes made to the funding request are saved.

### **Related Topics**

For more information on...	See...
How to search for a funding request	<a href="#">Searching for a Funding Request</a> on page 1353
<b>Funding Request</b> screen	<a href="#">Funding Request (Used for Viewing)</a> on page 1355
<b>Funding Request</b> zone	<a href="#">Funding Request</a> on page 1356
How to define a characteristic for a funding request	<a href="#">Defining a Characteristic for a Funding Request</a> on page 1373

## **Defining a Characteristic for a Funding Request**

### **Prerequisites**

To define a characteristic for a funding request, you should have:

- Characteristic types defined in the application (where the characteristic entity is set to **Funding Request**)

### **Procedure**

To define a characteristic for a funding request:

1. Ensure that the **Characteristics** section is expanded when you are editing a funding request.

The **Characteristics** section contains the following fields in a grid:

Field Name	Field Description	Mandatory (Yes or No)
Effective Date	Used to specify the date from when the characteristic is effective for the funding request.	Yes (Conditional) <b>Note:</b> This field is required when you are defining a characteristic for the funding request.
Characteristic Type	Used to indicate the characteristic type. <b>Note:</b> The list includes only those characteristic types where the characteristic entity is set to <b>Funding Request</b> .	Yes (Conditional) <b>Note:</b> This field is required when you are defining a characteristic for the funding request.
Characteristic Value	Used to specify the value for the characteristic type. <b>Note:</b> If you select a predefined characteristic type, the <b>Search</b> (🔍) icon appears corresponding to the <b>Characteristic Value</b> field. On clicking the <b>Search</b> icon, you can search for a predefined characteristic value. On specifying the value for a predefined characteristic type, the description of the characteristic value appears corresponding to the <b>Characteristic Value</b> field.	Yes (Conditional) <b>Note:</b> This field is required when you are defining a characteristic for the funding request.

- Enter the required details in the **Characteristics** section.
- If you want to define more than one characteristic for the funding request, click the **Add** (+) icon and then repeat step 2.

**Note:** However, if you want to remove a characteristic from the funding request, click the **Delete** (🗑️) icon corresponding to the characteristic.

### Related Topics

For more information on...	See...
How to edit a funding request	<a href="#">Editing a Funding Request</a> on page 1372

## Deleting a Funding Request

### Procedure

To delete a funding request:

- Search for the funding request in the **Funding Request** screen.

- In the **Search Results** section, click the link in the **Funding Request Information** column corresponding to the funding request that you want to delete.

The **Funding Request** screen appears.

- Click the **Delete** button in the **Funding Request** zone.

A message appears confirming whether you want to delete the funding request.

**Note:** The **Delete** button appears only when the funding request is in the **Draft** status.

- Click **OK**.

The funding request is deleted.

### Related Topics

For more information on...	See...
How to search for a funding request	<a href="#">Searching for a Funding Request</a> on page 1353
<b>Funding Request</b> screen	<a href="#">Funding Request (Used for Viewing)</a> on page 1355
<b>Funding Request</b> zone	<a href="#">Funding Request</a> on page 1356

## Canceling a Funding Request

### Prerequisites

To cancel a funding request, you should have:

- Reasons defined for the **Canceled** status of the **C1-FundingRequest** business object in the **Status Reason** screen

### Procedure

To cancel a funding request:

- Search for the funding request in the **Funding Request** screen.
- In the **Search Results** section, click the link in the **Funding Request Information** column corresponding to the funding request that you want to cancel.

The **Funding Request** screen appears.

- Click the **Cancel** button in the **Funding Request** zone.

The **Funding Request** window appears. It contains the following field:

Field Name	Field Description	Mandatory (Yes or No)
Status Reason	Used to indicate the reason why you want to cancel the funding request.  <b>Note:</b> The list includes only those reasons which are defined for the <b>Canceled</b> status of the <b>C1-FundingRequest</b> business object in the <b>Status Reason</b> screen.	Yes

**Note:** The **Cancel** button appears only when the funding request is in the **Draft** status.

- Select the cancellation reason from the **Status Reason** list.
- Click **Save**.

The status of all records in the funding request is changed to **Excluded** and the status of the funding request is changed to **Canceled**. The excluded bills can then be included in some other funding request.

### Related Topics

For more information on...	See...
How to search for a funding request	<a href="#">Searching for a Funding Request</a> on page 1353
<b>Funding Request</b> screen	<a href="#">Funding Request (Used for Viewing)</a> on page 1355
<b>Funding Request</b> zone	<a href="#">Funding Request</a> on page 1356

## Submitting a Funding Request

### Prerequisites

To submit a funding request, you should have:

- At least one debit or credit bill in the funding request
- Funding and garnishment adjustment types defined in the funding request
- Funding adjustment type defined in the application (where the **A/P Request Type Code** field is set to **REFUND**)
- Garnishment adjustment type defined in the application (where the **A/P Request Type Code** field is not set to **REFUND**)

### Procedure

To submit a funding request:

1. Search for the funding request in the **Funding Request** screen.
2. In the **Search Results** section, click the link in the **Funding Request Information** column corresponding to the funding request that you want to submit.

The **Funding Request** screen appears.

3. Click the **Submit** button in the **Funding Request** zone.

The system behaves in the following manner:



If...	Then...						
<p>The <b>Approval Required</b> option is selected in the funding request type using which the funding request is created</p>	<p>It calculates the sum of total debit and credit amount in the funding request. Depending on whether the sum total is debit or credit, it uses the debit or credit hierarchy in the approval profile (which is specified in the funding request type), respectively. Depending on the sum total amount, the system behaves in the following manner:</p> <table border="1" data-bbox="889 457 1466 1428"> <thead> <tr> <th data-bbox="898 468 1174 516">If...</th> <th data-bbox="1182 468 1458 516">Then...</th> </tr> </thead> <tbody> <tr> <td data-bbox="898 520 1174 905"> <p>The sum total is less than the minimum threshold amount in the approval hierarchy</p> </td> <td data-bbox="1182 520 1458 905"> <p>The system automatically approves the funding request and changes the status of the funding request to either <b>Deferred Processing</b> or <b>Create Funding</b> depending on whether the number of bills in the funding request exceeds the defer processing count.</p> </td> </tr> <tr> <td data-bbox="898 909 1174 1417"> <p>The sum total is equal to or greater than the threshold amount specified at the first level in the approval hierarchy</p> </td> <td data-bbox="1182 909 1458 1417"> <p>The system changes the status of the funding request to <b>Approval In Progress</b>. It creates a To Do using the To Do type specified in the approval profile and assigns it to the users with the To Do role defined at the first level in the approval hierarchy. In addition, it creates a log entry for the funding request when the To Do is created.</p> </td> </tr> </tbody> </table>	If...	Then...	<p>The sum total is less than the minimum threshold amount in the approval hierarchy</p>	<p>The system automatically approves the funding request and changes the status of the funding request to either <b>Deferred Processing</b> or <b>Create Funding</b> depending on whether the number of bills in the funding request exceeds the defer processing count.</p>	<p>The sum total is equal to or greater than the threshold amount specified at the first level in the approval hierarchy</p>	<p>The system changes the status of the funding request to <b>Approval In Progress</b>. It creates a To Do using the To Do type specified in the approval profile and assigns it to the users with the To Do role defined at the first level in the approval hierarchy. In addition, it creates a log entry for the funding request when the To Do is created.</p>
If...	Then...						
<p>The sum total is less than the minimum threshold amount in the approval hierarchy</p>	<p>The system automatically approves the funding request and changes the status of the funding request to either <b>Deferred Processing</b> or <b>Create Funding</b> depending on whether the number of bills in the funding request exceeds the defer processing count.</p>						
<p>The sum total is equal to or greater than the threshold amount specified at the first level in the approval hierarchy</p>	<p>The system changes the status of the funding request to <b>Approval In Progress</b>. It creates a To Do using the To Do type specified in the approval profile and assigns it to the users with the To Do role defined at the first level in the approval hierarchy. In addition, it creates a log entry for the funding request when the To Do is created.</p>						

If...	Then...
<p>The <b>Approval Required</b> option is not selected in the funding request type using which the funding request is created</p>	<p>The system changes the status of the funding request to either <b>Deferred Processing</b> or <b>Create Funding</b> depending on whether the number of bills in the funding request exceeds the defer processing count.</p> <p>Once the <b>Funding Request Periodic Monitor (C1-FNDRQ)</b> batch is executed, it checks whether there are any funding requests in the <b>Deferred Processing</b> status. If so, it changes the status of the funding request to <b>Create Funding</b>.</p> <p>Once the status of a funding request is changed to <b>Create Funding</b>, the system creates the A/P adjustment against a bill when the funding amount of the bill is in credit. It also creates non A/P adjustments using the garnishment adjustment type when the funding amount of a credit bill is transferred to the garnishment contracts of the account. However, if the funding amount of a bill is in debit, the funding amount is stamped as the automatic payment amount against the bill in the <b>CI_BILL_ACH</b> table. Then, on executing the <b>Create Automatic Payments and Refunds (APAYCRET)</b> batch, the system creates automatic payment and payment event for such bill.</p> <div style="border: 1px solid black; padding: 5px; margin-top: 10px;"> <p><b>Note:</b> The funding and garnishment adjustments are created in the <b>Frozen</b> status.</p> </div>

**Note:** The **Submit** button appears only when the funding request is in the **Draft** status.

### Related Topics

For more information on...	See...
How to search for a funding request	<a href="#">Searching for a Funding Request</a> on page 1353
<b>Funding Request</b> screen	<a href="#">Funding Request (Used for Viewing)</a> on page 1355
<b>Funding Request</b> zone	<a href="#">Funding Request</a> on page 1356

## Approving a Funding Request

You can view the number of funding requests which are pending for approval in the **Funding Request** screen. The approver can review, and accordingly approve, reject, or ask the submitter to resubmit the funding request based on the observations.

**Note:** The system will not allow you to approve, reject or resubmit a funding request submitted by you.

### Procedure

To approve a funding request:

1. Do either of the following:

If you want to...	Then...
Approve a funding request through the <b>Funding Request</b> screen	<ol style="list-style-type: none"> <li>1. Search for the funding request in the <b>Funding Request</b> screen.</li> <li>2. In the <b>Search Results</b> section, click the link in the <b>Funding Request Information</b> column corresponding to the funding request which you want to review.</li> </ol>
Approve a funding request from the <b>To Do List</b> screen	<ol style="list-style-type: none"> <li>1. Click the <b>Menu</b> link in the <b>Application</b> toolbar. A list appears.</li> <li>2. From the <b>Main</b> menu, select <b>To Do</b> and then click <b>To Do List</b>. The <b>To Do Type for User Search</b> window appears.</li> <li>3. Enter <b>C1-FNDAP</b> in the <b>To Do Type</b> field.</li> <li>4. Click the <b>Search</b> button corresponding to the <b>To Do Type</b> field. The <b>To Do List</b> screen appears.</li> <li>5. Select the <b>Open</b> option from the <b>Filter by</b> list to view all unassigned To Dos.</li> <li>6. Click the link in the <b>Message</b> column corresponding to the To Do of the funding request that you want to review.</li> </ol>

The **Funding Request** screen appears.

2. Review the details in the **Funding Request** screen.
3. If the information in the funding request is accurate, then click the **Approve** button in the **Funding Request** zone.

The system behaves in the following manner:

If...	Then...
The sum total of the debit and credit amount is equal to or greater than the threshold amount specified at the next level in the approval hierarchy	The system changes the status of the funding request to <b>Approval In Progress</b> . It creates a To Do using the To Do type specified in the approval profile and assigns it to the users with the To Do role defined at the next level in the approval hierarchy. In addition, it creates a log entry for the funding request when the To Do is created.

If...	Then...
<p>The sum total of the debit and credit amount is less than the threshold amount specified at the next level in the approval hierarchy</p>	<p>The system changes the status of the funding request to either <b>Deferred Processing</b> or <b>Create Funding</b> depending on whether the number of bills in the funding request exceeds the defer processing count.</p> <p>Once the <b>Funding Request Periodic Monitor (C1-FNDRQ)</b> batch is executed, it checks whether there are any funding requests in the <b>Deferred Processing</b> status. If so, it changes the status of the funding request to <b>Create Funding</b>.</p> <p>Once the status of a funding request is changed to <b>Create Funding</b>, the system creates the A/P adjustment against a bill when the funding amount of the bill is in credit. It also creates non A/P adjustments using the garnishment adjustment type when the funding amount of a credit bill is transferred to the garnishment contracts of the account. However, if the funding amount of a bill is in debit, the funding amount is stamped as the automatic payment amount against the bill in the <b>CI_BILL_ACH</b> table. Then, on executing the <b>Create Automatic Payments and Refunds (APAYCRET)</b> batch, the system creates automatic payment and payment event for such bill.</p> <div style="border: 1px solid black; padding: 5px; margin-top: 10px;"> <p><b>Note:</b> The funding and garnishment adjustments are created in the <b>Frozen</b> status.</p> </div>

**Note:** The **Approve** button appears only when:

- The funding request is in the **Approval In Progress** status.
- A user with the approval To Do role is reviewing the funding request.

### Related Topics

For more information on...	See...
How to search for a funding request	<a href="#">Searching for a Funding Request</a> on page 1353
<b>Funding Request</b> screen	<a href="#">Funding Request (Used for Viewing)</a> on page 1355
<b>Funding Request</b> zone	<a href="#">Funding Request</a> on page 1356

## Rejecting a Funding Request

### Prerequisites

To reject a funding request, you should have:

- Reasons defined for the **Rejected** status of the **C1-FundingRequest** business object in the **Status Reason** screen

**Note:** The system will not allow you to approve, reject or resubmit a funding request submitted by you.

### Procedure

To reject a funding request:

1. Do either of the following:

If you want to...	Then...
Reject a funding request through the <b>Funding Request</b> screen	<ol style="list-style-type: none"> <li>1. Search for the funding request in the <b>Funding Request</b> screen.</li> <li>2. In the <b>Search Results</b> section, click the link in the <b>Funding Request Information</b> column corresponding to the funding request which you want to review.</li> </ol>
Reject a funding request from the <b>To Do List</b> screen	<ol style="list-style-type: none"> <li>1. Click the <b>Menu</b> link in the <b>Application</b> toolbar. A list appears.</li> <li>2. From the <b>Main</b> menu, select <b>To Do</b> and then click <b>To Do List</b>. The <b>To Do Type for User Search</b> window appears.</li> <li>3. Enter <b>C1-FNDAP</b> in the <b>To Do Type</b> field.</li> <li>4. Click the <b>Search</b> button corresponding to the <b>To Do Type</b> field. The <b>To Do List</b> screen appears.</li> <li>5. Select the <b>Open</b> option from the <b>Filter by</b> list to view all unassigned To Dos.</li> <li>6. Click the link in the <b>Message</b> column corresponding to the To Do of the funding request that you want to review.</li> </ol>

The **Funding Request** screen appears.

2. Review the details in the **Funding Request** screen.
3. If the information in the funding request is incorrect, then click the **Reject** button in the **Funding Request** zone.

The **Reject Funding Request** window appears. It contains following fields:

Field Name	Field Description	Mandatory (Yes or No)
Status Reason	Used to indicate the reason why you want to reject the funding request.  <div style="border: 1px solid black; padding: 5px;"> <b>Note:</b> The list includes only those reasons which are defined for the <b>Rejected</b> status of the <b>C1-FundingRequest</b> business object in the <b>Status Reason</b> screen.         </div>	Yes
Comments	Used to specify additional information while rejecting the funding request.	No

**Note:** The **Reject** button appears only when:

- The funding request is in the **Approval In Progress** status.
- A user with the approval To Do role is reviewing the funding request.

4. Select the rejection reason from the **Status Reason** list.
5. Click **Save**.

The status of the funding request is changed to **Rejected**.

### **Related Topics**

<b>For more information on...</b>	<b>See...</b>
How to search for a funding request	<a href="#">Searching for a Funding Request</a> on page 1353
<b>Funding Request</b> screen	<a href="#">Funding Request (Used for Viewing)</a> on page 1355
<b>Funding Request</b> zone	<a href="#">Funding Request</a> on page 1356

## **Requesting to Resubmit a Funding Request**

### **Procedure**

To request for resubmitting a funding request:

1. Do either of the following:

<b>If you want to...</b>	<b>Then...</b>
Request for resubmitting a funding request through the <b>Funding Request</b> screen	<ol style="list-style-type: none"> <li>1. Search for the funding request in the <b>Funding Request</b> screen.</li> <li>2. In the <b>Search Results</b> section, click the link in the <b>Funding Request Information</b> column corresponding to the funding request which you want to review.</li> </ol>
Request for resubmitting a funding request from the <b>To Do List</b> screen	<ol style="list-style-type: none"> <li>1. Click the <b>Menu</b> link in the <b>Application</b> toolbar. A list appears.</li> <li>2. From the <b>Main</b> menu, select <b>To Do</b> and then click <b>To Do List</b>. The <b>To Do Type for User Search</b> window appears.</li> <li>3. Enter <b>C1-FNDAP</b> in the <b>To Do Type</b> field.</li> <li>4. Click the <b>Search</b> button corresponding to the <b>To Do Type</b> field. The <b>To Do List</b> screen appears.</li> </ol>

If you want to...	Then...
	<ol style="list-style-type: none"> <li>5. Select the <b>Open</b> option from the <b>Filter by</b> list to view all unassigned To Dos.</li> <li>6. Click the link in the <b>Message</b> column corresponding to the To Do of the funding request that you want to review.</li> </ol>

The **Funding Request** screen appears.

2. Review the details in the **Funding Request** screen.
3. If the information in the funding request is incomplete and you want the submitter to make the required changes and resubmit the request, click the **Re Submit** button in the **Funding Request** zone.

The **Resubmit Funding Request** window appears. It contains the following field:

Field Name	Field Description	Mandatory (Yes or No)
Comments	Used to specify the changes which the submitter should make in the funding request before resubmitting it for approval.	Yes

**Note:** The **Re Submit** button appears only when:

- The funding request is in the **Approval In Progress** status.
- A user with the approval To Do role is reviewing the funding request.

4. Enter the comments in the respective field and then click **Save**.

A To Do is created using the submitter To Do type and assigned to all users with a submitter To Do role specified in the funding request type. In addition, the status of the funding request is changed to **Draft**.

### **Related Topics**

For more information on...	See...
How to search for a funding request	<a href="#">Searching for a Funding Request</a> on page 1353
<b>Funding Request</b> screen	<a href="#">Funding Request (Used for Viewing)</a> on page 1355
<b>Funding Request</b> zone	<a href="#">Funding Request</a> on page 1356

## **Withdrawing a Funding Request**

### **Prerequisites**

To withdraw a funding request, you should have:

- Submitter To Do role (which is specified in the funding request type) associated with the **C1-FNDAP** To Do type

### **Procedure**

To withdraw a funding request:

1. Search for the funding request in the **Funding Request** screen.

2. In the **Search Results** section, click the link in the **Funding Request Information** column corresponding to the funding request that you want to withdraw.

The **Funding Request** screen appears.

3. If you want to make some changes in the funding request which is already sent for approval, click the **Withdraw** button in the **Funding Request** zone.

The status of the funding request is changed to **Draft**. The submitter can then make the required changes and resubmit the funding request for approval. The To Do for approver is automatically closed when the submitter withdraws the funding request. Note that the To Do for approver is automatically closed only when the submitter To Do role is associated with the To Do type specified in the approval profile.

**Note:** The **Withdraw** button appears only when:

- The funding request is in the **Approval In Progress** status.
- A user with the submitter To Do role is viewing the funding request.

### **Related Topics**

<b>For more information on...</b>	<b>See...</b>
How to search for a funding request	<a href="#">Searching for a Funding Request</a> on page 1353
<b>Funding Request</b> screen	<a href="#">Funding Request (Used for Viewing)</a> on page 1355
<b>Funding Request</b> zone	<a href="#">Funding Request</a> on page 1356

## **Transferring the Funding Amount of a Credit Bill to a Garnishment Contract**

### **Prerequisites**

To transfer the funding amount of a credit bill to a garnishment contract, you should have:

- At least one garnishment contract on the account

**Note:** The garnishment contract is a contract which is created using a contract type where the **Special Role Flag** field is set to **Garnishment**.

### **Procedure**

To transfer the funding amount of a credit bill to a garnishment contract:

1. Search for the funding request in the **Funding Request** screen.
2. In the **Search Results** section, click the link in the **Funding Request Information** column corresponding to the funding request whose details you want to edit.

The **Funding Request** screen appears.

3. Click the **Bills** tab.

The **Bills** tab appears.

4. In the **Selected Bills** zone, click the link on the value **Y** in the **Garnishment Contract** column corresponding to a credit bill whose funding amount you want to transfer to a garnishment contract of the account.

The **Edit Garnishment Details** screen appears. It contains the following field:



Field Name	Field Description
Bill Information	Indicates the credit bill whose funding amount you want to transfer to a garnishment contract of the account.

In addition, this screen contains the following fields in a grid:

Field Name	Field Description	Mandatory (Yes or No)
Garnishment Contract	Used to indicate the garnishment contract of the account.	Yes
Garnishment Amount	Used to specify the amount that you want to transfer to the garnishment contract.	Yes

- Enter the required details in the **Edit Garnishment Details** screen.
- If you want to transfer the funding amount of the credit bill to more than one garnishment contract of the account, click the **Add (+)** icon and then repeat step 5.

**Note:** However, if you want to remove a garnishment record from the funding request, click the **Delete (🗑)** icon corresponding to the garnishment record.

- Click **Save**.

The changes made to the funding request are saved.

### Related Topics

For more information on...	See...
How to search for a funding request	<a href="#">Searching for a Funding Request</a> on page 1353
<b>Funding Request</b> screen	<a href="#">Funding Request (Used for Viewing)</a> on page 1355
<b>Selected Bills</b> zone	<a href="#">Selected Bills</a> on page 1364

## Viewing the Garnishment Details of a Credit Bill

### Procedure

To view the garnishment details of a credit bill:

- Search for the funding request in the **Funding Request** screen.
- In the **Search Results** section, click the link in the **Funding Request Information** column corresponding to the funding request whose details you want to view.

The **Funding Request** screen appears.

- Click the **Bills** tab.

The **Bills** tab appears.

- In the **Selected Bills** zone, click the **Broadcast (📡)** icon in the **Garnishment** column corresponding to the credit bill whose garnishment details you want to view.

The **View Garnishment Details** screen appears. It contains the following field:

Field Name	Field Description
Bill Info	Indicates the credit bill whose garnishment details you are viewing.

In addition, this screen contains the following columns:

Column Name	Column Description
Garnishment Contract	Indicates the garnishment contract of the account against which amount from the credit bill is transferred.
Garnishment Amount	Displays the amount which is transferred to the garnishment contract.

**Note:**  
 The **Garnishment** column does not appear when the funding request is in the **Draft** status.  
 The **View** () icon appears in the **Garnishment** column only when the funding request is in the **Processed** status.

### Related Topics

For more information on...	See...
How to search for a funding request	<a href="#">Searching for a Funding Request</a> on page 1353
<b>Funding Request</b> screen	<a href="#">Funding Request (Used for Viewing)</a> on page 1355
<b>Selected Bills</b> zone	<a href="#">Selected Bills</a> on page 1364

## Viewing the Payments Created Through a Funding Request

### Procedure

To view the payments created through a funding request:

1. Search for the funding request in the **Funding Request** screen.
2. In the **Search Results** section, click the link in the **Funding Request Information** column corresponding to the funding request whose details you want to view.

The **Funding Request** screen appears.

3. Click the **Bills** tab.

The **Bills** tab appears.

4. In the **Selected Bills** zone, click the **Broadcast**

 icon corresponding to a debit bill whose payment details you want to view.

The **Funding Payments Details** zone appears.

**Note:** The **Broadcast** () icon appears only when the funding request is in the **Processed** status.

5. View the payments created for the debit bill through the funding request in the **Funding Payments Details** zone.

**Note:** The data appears in the **Funding Payments Details** zone only when the **Create Automatic Payments and Refunds (APAYCRET)** batch is executed to create the automatic payment and payment event for the debit bill. For more information about the batch, refer to *Oracle Revenue Management and Billing Batch Guide*.

### Related Topics

For more information on...	See...
How to search for a funding request	<a href="#">Searching for a Funding Request</a> on page 1353
<b>Funding Request</b> screen	<a href="#">Funding Request (Used for Viewing)</a> on page 1355
<b>Selected Bills</b> zone	<a href="#">Selected Bills</a> on page 1364
<b>Funding Payments Details</b> zone	<a href="#">Funding Payment Details</a> on page 1367

## Viewing the Adjustments Created Through a Funding Request

### Procedure

To view the adjustments created through a funding request:

1. Search for the funding request in the **Funding Request** screen.
2. In the **Search Results** section, click the link in the **Funding Request Information** column corresponding to the funding request whose details you want to view.

The **Funding Request** screen appears.

3. Click the **Bills** tab.

The **Bills** tab appears.

4. In the **Selected Bills** zone, click the **Broadcast**  icon corresponding to a credit bill whose adjustment details you want to view.

The **Funding Adjustments** zone appears.

**Note:** The **Broadcast**  icon appears only when the funding request is in the **Processed** status.

5. View the A/P adjustments and garnishment adjustments (if any) created for the credit bill through the funding request in the **Funding Adjustments** zone.

### Related Topics

For more information on...	See...
How to search for a funding request	<a href="#">Searching for a Funding Request</a> on page 1353
<b>Funding Request</b> screen	<a href="#">Funding Request (Used for Viewing)</a> on page 1355
<b>Selected Bills</b> zone	<a href="#">Selected Bills</a> on page 1364
<b>Funding Adjustments</b> zone	<a href="#">Funding Adjustments</a> on page 1367

## Viewing the Log of a Funding Request

### Procedure

To view the log of a funding request:

1. Search for the funding request in the **Funding Request** screen.
2. In the **Search Results** section, click the link in the **Funding Request Information** column corresponding to the funding request whose log you want to view.

The **Funding Request** screen appears.

3. Click the **Log** tab.

The **Log** tab appears.

4. View the complete trail of actions performed on the funding request in the **Funding Request Log** zone.

#### Related Topics

For more information on...	See...
How to search for a funding request	<a href="#">Searching for a Funding Request</a> on page 1353
How to add a log entry for a funding request	<a href="#">Adding a Log Entry for a Funding Request</a> on page 1388
<b>Funding Request</b> screen	<a href="#">Funding Request (Used for Viewing)</a> on page 1355
<b>Funding Request Log</b> zone	<a href="#">Funding Request Log</a> on page 1367

## Adding a Log Entry for a Funding Request

### Procedure

To add a log entry for a funding request:

1. Search for the funding request in the **Funding Request** screen.
2. In the **Search Results** section, click the link in the **Funding Request Information** column corresponding to the funding request whose log you want to edit.

The **Funding Request** screen appears.

3. Click the **Log** tab.

The **Log** tab appears.

4. Click the **Add Log Entry** link in the upper right corner of the **Funding Request Log** zone.

The **Add Request Log** window appears. It contains the following fields:

Field Name	Field Description	Mandatory (Yes or No)
Request Information	Displays information about the funding request.	Not applicable
Log Details	Used to specify additional comments on the funding request.	Yes

5. Enter the comments in the **Log Details** field.

6. Click **Save**.

The log entry is added in the **Funding Request Log** zone.

#### Related Topics

For more information on...	See...
How to search for a funding request	<a href="#">Searching for a Funding Request</a> on page 1353
<b>Funding Request</b> screen	<a href="#">Funding Request (Used for Viewing)</a> on page 1355
<b>Funding Request Log</b> zone	<a href="#">Funding Request Log</a> on page 1367

---

# Chapter 21

---

## Refund/Write Off Request

---

### Topics:

- [Refund Request \(Without Approval\) Status Transition](#)
- [Refund Request \(With Approval\) Status Transition](#)
- [Write Off Request \(Without Approval\) Status Transition](#)
- [Write Off Request \(With Approval\) Status Transition](#)
- [Algorithms Used in C1-RefundReq](#)
- [Algorithms Used in C1-WORequest](#)
- [Prerequisites](#)
- [Refund/Write Off Request Type](#)
- [Refund/Write Off Request](#)
- [Refund Request](#)
- [Write Off Request](#)

Oracle Revenue Management and Billing allows you to refund and write off amount to the account. If the amount received from the payor account is matched against the suspense or excess credit contract, the system facilitates you to refund the amount to the payor. In addition, you can refund the amount of a credit bill line item, such as credit bill segment or adjustment, if required. To refund the amount to the account holder, you need to create refund adjustments through a refund request. While creating a refund request, you need to specify the refund request type using which you want to create the refund request. It is the refund request type which helps the system to determine:

- Whether the refund request must be approved before creating refund adjustments in the system
- Approval profile using which the refund request must be approved
- Whether multi-level or single-level approval is required while creating refund adjustments in the system
- Tolerance limit for refund (i.e. minimum refund amount)
- Adjustment type using which the write up adjustment must be created when the total refund amount is less than the minimum refund amount
- Default adjustment type using which refund adjustments must be created

The system allows you to create refund adjustments only using those adjustment types where A/P request type is defined. Once the refund adjustments are created, the A/P Extract process will extract the information and accordingly refund the amount to the payor. During the refund request process, a refund request goes through various statuses in its lifecycle. For more information about the refund request statuses, see [Refund Request \(Without Approval\) Status Transition](#) on page 1391 and [Refund Request \(With Approval\) Status Transition](#) on page 1391.

Note that the lifecycle of a refund request is driven by the business object using which the refund request is created. A refund request business object named **C1-RefundReq** is shipped with the product. The refund request feature explained in this document is articulated based on the lifecycle and logic defined in the **C1-RefundReq** business object.

Similarly, the system facilitates you to write off the amount to the account through a write off request. While creating a write off request, you need to specify the write off request type using which you want to create the write off request. It is the write off request type which helps the system to determine:

- Whether the write off request must be approved before creating write off adjustments in the system
- Approval profile using which the write off request must be approved

- Whether multi-level or single-level approval is required while creating write off adjustments in the system
- Default adjustment type using which write off adjustments must be created

The system allows you to create write off adjustments only using those adjustment types where A/P request type is not defined. During the write off request process, a write off request goes through various statuses in its lifecycle. For more information about the write off request statuses, see [Write Off Request \(Without Approval\) Status Transition](#) on page 1392 and [Write Off Request \(With Approval\) Status Transition](#) on page 1393.

Note that the lifecycle of a write off request is driven by the business object using which the write off request is created. A write off request business object named **C1-WORequest** is shipped with the product. The write off request feature explained in this document is articulated based on the lifecycle and logic defined in the **C1-WORequest** business object.

For more information on how to setup the refund and write off request processes, see [Prerequisites](#) on page 1403.

## Refund Request (Without Approval) Status Transition

---

The following figure graphically indicates how a refund request moves from one status to another when approval workflow is off:

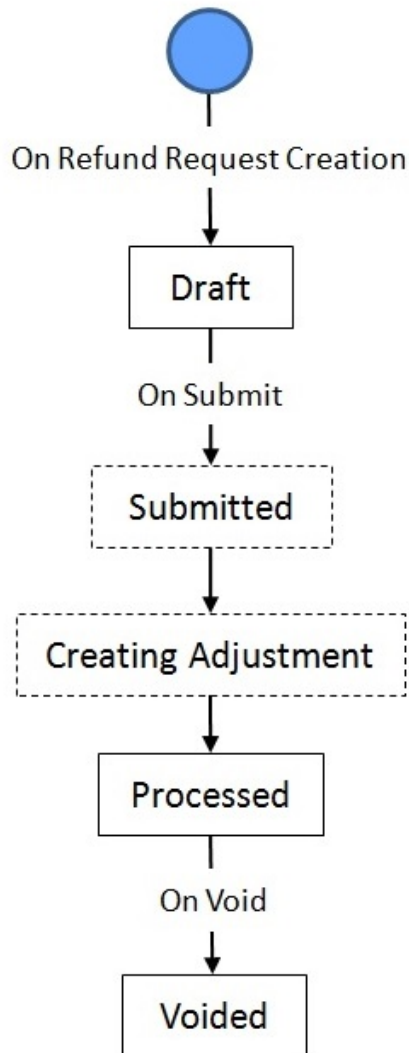

## Refund Request (With Approval) Status Transition

---

The following figure graphically indicates how a refund request moves from one status to another when approval workflow is on:

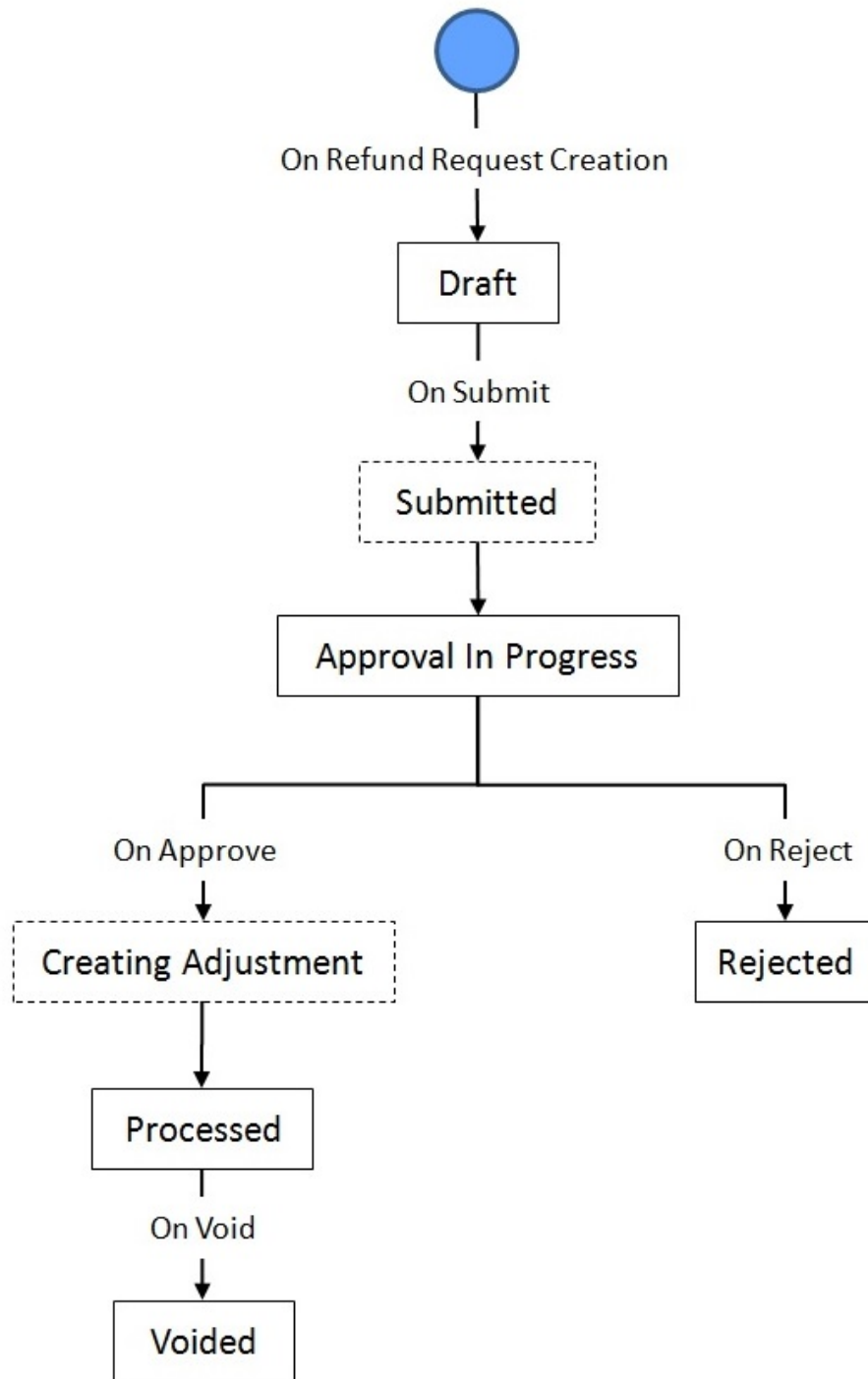

## Write Off Request (Without Approval) Status Transition

---

The following figure graphically indicates how a write off request moves from one status to another when approval workflow is off:



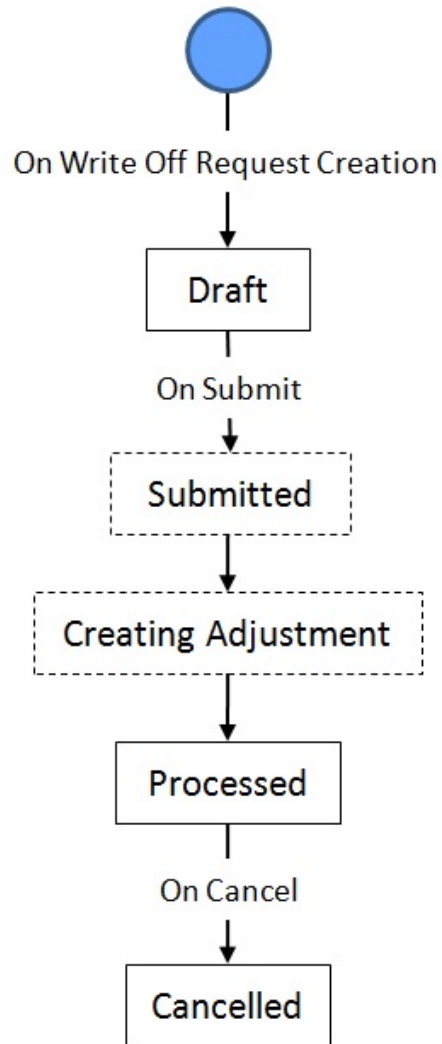

## Write Off Request (With Approval) Status Transition

---

The following figure graphically indicates how a write off request moves from one status to another when approval workflow is on:

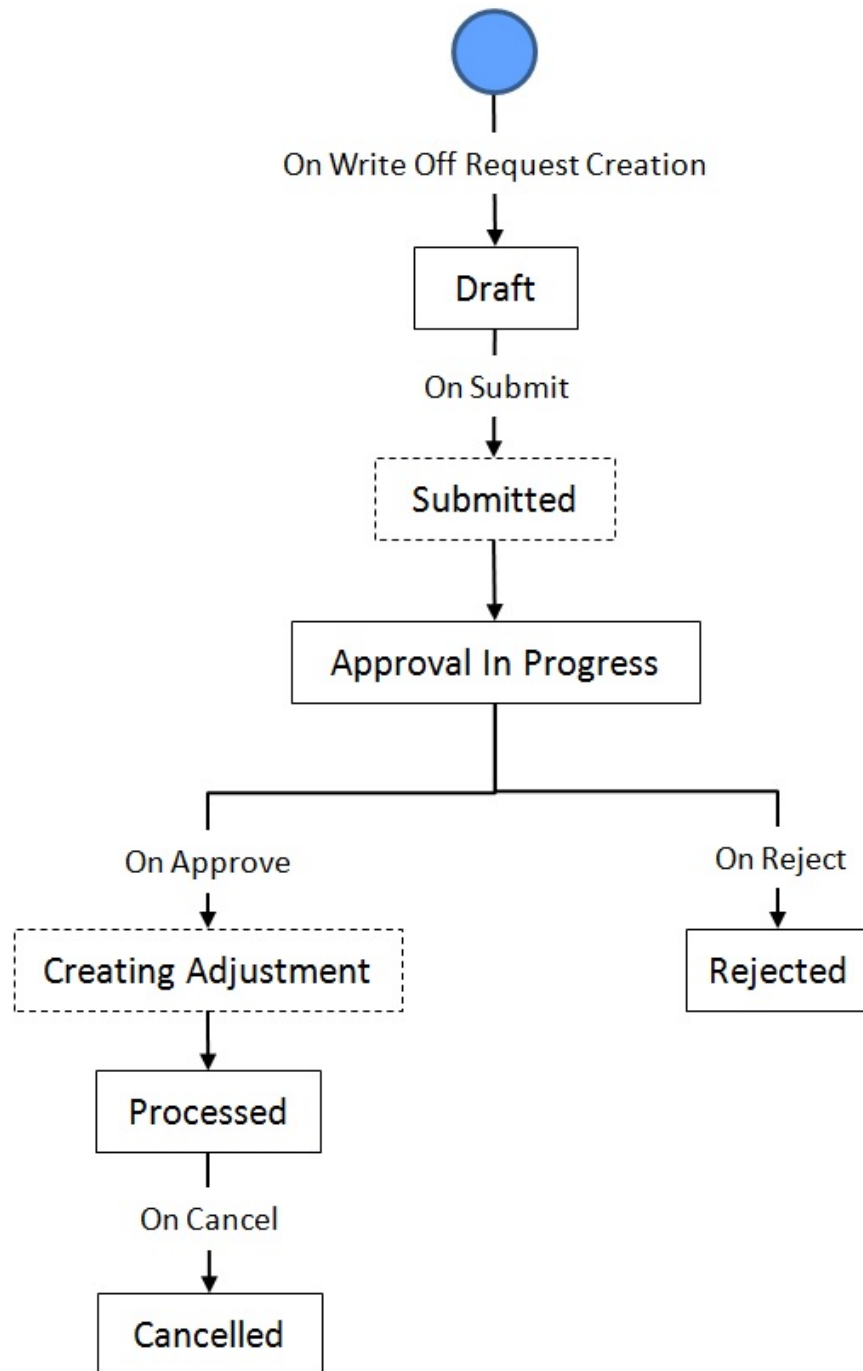

## Algorithms Used in C1-RefundReq

The following table lists the algorithms which are attached to the **C1-RefundReq** business object:

System Event	Algorithm	Algorithm Type	Description
Information	C1-REFREQINF	C1-REFREQINF	<p>This algorithm generates the refund and write off request information string which appears throughout the application. It concatenates the following fields:</p> <ul style="list-style-type: none"> <li>• Refund or Write Off Request Type Description</li> <li>• Refund or Write Off Request Status Description</li> <li>• Refund or Write Off Request ID</li> </ul>
Post-Processing	C1-REFWOPOSP	C1-REFWOPOSP	<p>This algorithm recalculates and updates the total refund amount in the <b>Refund Request</b> zone when you change the refund amount against an entity while editing a refund request.</p>
Validation	C1-REFUNDVAL	C1-REFUNDVAL	<p>This algorithm validates the following for each entity that you have selected in the refund request:</p> <ul style="list-style-type: none"> <li>• The mandatory data, such as refund amount and adjustment type, is specified.</li> <li>• The refund amount is not less than zero.</li> <li>• The refund amount is not greater than the entity amount.</li> <li>• The refund amount is not greater than the eligible refund amount.</li> <li>• The partial refund is not done at the payment event or bill level.</li> </ul>

The following table lists the algorithms which are used in the lifecycle of the **C1-RefundReq** business object:

Status	System Event	Algorithm	Algorithm Type	Description
Draft	Enter	C1-REF-DFT	C1-REF-DFT	<p>This algorithm fetches the account's main customer's name and address and displays in the <b>Refund Request</b> zone. In addition, when you refund the payments from the <b>Payment Event Summary</b> screen, this algorithm does the following:</p> <ul style="list-style-type: none"> <li>• The total eligible refund amount is calculated and accordingly displayed in the <b>Refund Request</b> screen.</li> <li>• The default refund adjustment type specified in the refund request type is fetched and displayed against the selected payment event or payments.</li> <li>• On selecting a payment event for refund, if all payments in the payment event are matched against the same suspense or excess credit contract, the payment event is added in the <b>Refund Details</b> zone. However, if the payments in the payment event are matched against different suspense or excess credit contracts, the payments of the payment event are added in the <b>Refund Details</b> zone.</li> </ul>
Submitted	Enter	C1-REFUNDSUB	C1-REFUNDSUB	<p>This algorithm checks the following:</p> <ul style="list-style-type: none"> <li>• Whether the approval is required for the refund request. If the approval is required for a refund request, the status of the refund request is changed to <b>Approval In Progress</b>. However, if the approval is not required for a refund request, the status of the refund request is changed to <b>Creating Adjustment</b>.</li> <li>• At least one entity, such as payment event, payment, or credit bill line item (such as credit bill segment or adjustment) is selected in the refund request.</li> <li>• Whether the approval profile attached to the refund request type has the credit hierarchy and C1-REFRQ To Do type defined.</li> </ul>

Status	System Event	Algorithm	Algorithm Type	Description
Approval In Progress	Enter	C1-REFUNDAPP	C1-REFUNDAPP	<p>This algorithm creates the following:</p> <ul style="list-style-type: none"> <li>• A To Do using the To Do type specified in the approval profile which is attached to the refund request type. The To Do is sent to the appropriate users in the approval hierarchy depending on whether hierarchical approval is required or not.</li> <li>• A log entry is added when a To Do is created using the To Do type.</li> </ul>
Approved	Enter	C1-REFAPPRVD	C1-REFAPPRVD	<p>This algorithm is triggered when the approver clicks the <b>Approve</b> button. It checks whether the approval is required from users at the next level in the approval hierarchy. If the approval is required from the next level in the approval hierarchy, the status of the refund request is changed to <b>Approval In Progress</b> and the algorithm attached to the <b>Approval In Progress</b> status is invoked. If further approval is not required, the status of the refund request is changed to <b>Creating Adjustment</b>.</p>
Rejected	-	-	-	-

Status	System Event	Algorithm	Algorithm Type	Description
Creating Adjustment	Enter	C1-REFADJCRI	C1-REFADJCRI	<p>This algorithm does the following:</p> <ul style="list-style-type: none"> <li>Creates the refund adjustments for the refund request. These refund adjustments are created in the <b>Frozen</b> status. The adjustment ID is displayed corresponding to the entity in the <b>Refund Details</b> zone.</li> <li>Stamps the bill ID of credit line item on the adjustment and the corresponding financial transaction.</li> <li>If a match event is present for the credit bill line item and for payments which are matched against the excess credit contract, the existing match event is stamped on the refund or write up adjustment and the corresponding financial transaction. However, when a match event is not present for payments which are matched against the suspense contract or if the match event does not exist, a new match event is created and stamped on the refund or write up adjustment and the corresponding financial transaction.</li> <li>If you are doing a partial refund for any entity, the corresponding match event status is set to <b>Open</b>. However, if you are refunding the entire eligible amount, the corresponding match event status is set to <b>Balanced</b>.</li> <li>The details of the refund adjustments are added in the <b>A/P Check Request (CL_ADJ_APREQ)</b> table.</li> <li>If a write up adjustment is created, the write up adjustment type specified in the refund request type is displayed corresponding to the entity in the <b>Refund Details</b> zone.</li> </ul>
Processed	-	-	-	-

Status	System Event	Algorithm	Algorithm Type	Description
Voided	Enter	C1-REFVOID	C1-REFVOID	<p>This algorithm is invoked on click of the <b>Void</b> button for a refund request which is in processed state.</p> <p>The algorithm cancels all the frozen adjustments created for the refund request.</p> <p>The algorithm fetches the adjustment cancel reason required for cancelling the adjustments in the status reason characteristics (<b>F1_BUS_OBJ_STATUS_RSN_CHAR</b> table). If the reason is not found, it will use the status reason selected by the user</p>

## Algorithms Used in C1-WORequest

The following table lists the algorithms which are attached to the **C1-WORequest** business object:

System Event	Algorithm	Algorithm Type	Description
Information	C1-REFREQINF	C1-REFREQINF	<p>This algorithm generates the refund and write off request information string which appears throughout the application. It concatenates the following fields:</p> <ul style="list-style-type: none"> <li>• Refund or Write Off Request Type Description</li> <li>• Refund or Write Off Request Status Description</li> <li>• Refund or Write Off Request ID</li> </ul>
Post-Processing	C1-WOPOSP	C1-WOPOSP	<p>This algorithm recalculates and updates the total write off amount in the <b>Write Off Request</b> zone when you change the write off amount against an entity while editing a write off request.</p>

System Event	Algorithm	Algorithm Type	Description
Validation	C1-WOBOVAL	C1-WOBOVAL	<p>This algorithm validates the following for each entity that you have selected in the write off request:</p> <ul style="list-style-type: none"> <li>• The mandatory data, such as write off amount and adjustment type, is specified.</li> <li>• The write off amount is not less than zero.</li> <li>• The write off amount is not greater than the entity amount.</li> <li>• The write off amount is not greater than the eligible write off amount.</li> <li>• The partial write off is not done at the bill level.</li> <li>• The A/P Request Type is not defined in the selected adjustment type.</li> </ul>

The following table lists the algorithms which are used in the lifecycle of the **C1-WORequest** business object:

Status	System Event	Algorithm	Algorithm Type	Description
Draft	-	-	-	-
Submitted	Enter	C1-WOSUBMIT	C1-WOSUBMIT	<p>This algorithm checks the following:</p> <ul style="list-style-type: none"> <li>• Whether the approval is required for the write off request. If the approval is required for a write off request, the status of the write off request is changed to <b>Approval In Progress</b>. However, if the approval is not required for a write off request, the status of the write off request is changed to <b>Creating Adjustment</b>.</li> <li>• At least one debit bill line item (such as debit bill segment or adjustment) is selected in the write off request.</li> <li>• Whether the approval profile attached to the write off request type has the debit hierarchy and C1-WOREQ To Do type defined.</li> </ul>



Status	System Event	Algorithm	Algorithm Type	Description
Approval In Progress	Enter	C1-WOAPPROVL	C1-WOAPPROVL	<p>This algorithm creates the following:</p> <ul style="list-style-type: none"> <li>• A To Do using the To Do type specified in the approval profile which is attached to the write off request type. The To Do is sent to the appropriate users in the approval hierarchy depending on whether hierarchical approval is required or not.</li> <li>• A log entry is added when a To Do is created using the To Do type.</li> </ul>
Approved	Enter	C1-WOAPPROVD	C1-WOAPPROVD	<p>This algorithm is triggered when the approver clicks the <b>Approve</b> button. It checks whether the approval is required from users at the next level in the approval hierarchy. If the approval is required from the next level in the approval hierarchy, the status of the write off request is changed to <b>Approval In Progress</b> and the algorithm attached to the <b>Approval In Progress</b> status is invoked. If further approval is not required, the status of the write off request is changed to <b>Creating Adjustment</b>.</p>
Rejected	-	-	-	-

Status	System Event	Algorithm	Algorithm Type	Description
Creating Adjustment	Enter	C1-WOAJCRT	C1-WOAJCRT	<p>This algorithm does the following:</p> <ul style="list-style-type: none"> <li>Creates the write off adjustments for the write off request. These write off adjustments are created in the <b>Frozen</b> status. The adjustment ID is displayed corresponding to the entity in the <b>Write Off Details</b> zone.</li> <li>Stamps the bill ID of debit line item on the adjustment and the corresponding financial transaction.</li> <li>If a match event is present for the debit bill line item, the existing match event is stamped on the write off adjustment and the corresponding financial transaction. However, if the match event does not exist, a new match event is created and stamped on the write off adjustment and the corresponding financial transaction.</li> <li>If you are doing a partial write off for any entity, the corresponding match event status is set to <b>Open</b>. However, if the entire eligible amount is written off, the corresponding match event status is set to <b>Balanced</b>.</li> </ul>
Processed	-	-	-	-
Cancelled	Enter	C1-WOCANCEL	C1-WOCANCEL	<p>This algorithm is invoked on click of the <b>Cancel</b> button for a write off request which is in the <b>Processed</b> state.</p> <p>This algorithm cancels all the frozen adjustments created for the write off request.</p> <p>The algorithm fetches the adjustment cancel reason required for cancelling the adjustments in the status reason characteristics (<b>F1_BUS_OBJ_STATUS_RSN_CHAR</b> table). If the reason is not found, it will use the status reason selected by the user.</p>

## Prerequisites

---

To setup the refund request process, you need to do the following:

- Define the required adjustment types (for creating refund adjustments) where A/P request type is defined
- Define the required adjustment types (for creating write up adjustments) where A/P request type is not defined
- Define the required characteristic types where the characteristic entity is set to **Refund Write Off Request Type**
- Define the required characteristic types where the characteristic entity is set to **Refund Write Off Request**
- Define voided and rejected status reasons for the **C1-RefundReq** business object
- Assign the **C1-REFRQ** To Do type to a To Do role whose users must receive To Do generated while submitting a refund request for approval
- Define the required approval profiles with the credit hierarchy and **C1-REFRQ** To Do type
- Define an algorithm of the **C1-ADI-INFO** algorithm type and attach to the **Adjustment Information** system event in the **Algorithms** tab of the **Installation Options — Framework** screen
- Define the required refund request types in the system

To setup the write off request process, you need to do the following:

- Define the required adjustment types (for creating write off adjustments) where A/P request type is not defined
- Define the required characteristic types where the characteristic entity is set to **Refund Write Off Request Type**
- Define the required characteristic types where the characteristic entity is set to **Refund Write Off Request**
- Define cancelled and rejected status reasons for the **C1-WOREquest** business object
- Assign the **C1-WOREQ** To Do type to a To Do role whose users must receive To Do generated while submitting a write off request for approval
- Define the required approval profiles with the debit hierarchy and **C1-WOREQ** To Do type
- Define an algorithm of the **C1-ADI-INFO** algorithm type and attach to the **Adjustment Information** system event in the **Algorithms** tab of the **Installation Options — Framework** screen
- Define the required write off request types in the system

## Refund/Write Off Request Type

---

Oracle Revenue Management and Billing allows you to define:

- **Refund Request Type** — It is used to create a refund request. You can define multiple refund request types in the system. A refund request type helps the system to determine:
  - Whether the refund request must be approved before creating refund adjustments in the system
  - Approval profile using which the refund request must be approved
  - Whether multi-level or single-level approval is required while creating refund adjustments in the system
  - Tolerance limit for refund (i.e. minimum refund amount)
  - Adjustment type using which the write up adjustment must be created when the total refund amount is less than the minimum refund amount
  - Default adjustment type using which refund adjustments must be created

- **Write Off Request Type** — It is used to create a write off request. You can define multiple write off request types in the system. A write off request type helps the system to determine:
  - Whether the write off request must be approved before creating write off adjustments in the system
  - Approval profile using which the write off request must be approved
  - Whether multi-level or single-level approval is required while creating write off adjustments in the system
  - Default adjustment type using which write off adjustments must be created

While defining a refund or write off request type where approval workflow is required, you need to select the **Approval Required** check box. If the **Approval Required** check box is selected, the refund or write off request (which is created using the refund or write off request type) is sent for approval before creating the refund or write off adjustments. However, if the **Approval Required** check box is not selected, the refund or write off adjustments are created immediately on submitting a refund or write off request. The approval process is configured through the approval profile. The approval profile allows you to define the approval hierarchy. You can define a debit and credit hierarchy in the approval profile using the threshold amount. The debit approval hierarchy is used for approving write off request and credit approval hierarchy is used for approving refund request. Therefore, while defining an approval profile for refund, you need to define credit hierarchy and set the To Do Type to **C1-REFRQ**. However, while defining an approval profile for write off, you need to define debit hierarchy and set the To Do Type to **C1-WOREQ**.

You can define an approval hierarchy where users with different To Do role at each level can approve or reject the refund or write off request. For example, you can define an approval profile called A1 with two levels of approval. At the first level, a user with the *Manager* To Do role will approve or reject the refund or write off request, and at the second level, a user with the *Senior Manager* To Do role will approve or reject the refund or write off request. On submitting a refund or write off request where approval is required, a notification in the form of To Do is sent to all users with the To Do role defined at the first level in the hierarchy. Once the request is approved at the first level, a notification is sent to all users with the To Do role defined at the next level in the hierarchy. This process continues till the approval is received from all levels in the hierarchy. Once users at all levels approve the refund or write off request, the refund or write off adjustments are created. However, if an approver at any level in the hierarchy rejects the request, the refund or write off adjustments are not created.

The approval hierarchy is controlled by the threshold amount. For example, you define an approval profile called A1 with two levels of approval — First Level (Threshold Amount: 300, To Do Role: *Manager*) and Second Level (Threshold Amount: 500, To Do Role: *Senior Manager*). Now, if the total refund or write off amount is equal to 300 or less than 500, then the approval is required only from the first level in the hierarchy and not from the second level in the hierarchy. However, if the total refund or write off amount is equal to or greater than 500, then the approval is required from the first level and then from the second level in the hierarchy. But, if the total refund or write off amount is less than 300, then the approval is not required from any levels in the hierarchy. The system will automatically approve the refund or write off request and create the refund or write off adjustments.

The system supports both single-level and multi-level approval process while approving refund or write off request. If the **Hierarchical Approval** check box is selected while defining a refund or write off request type, the approval hierarchy defined in the approval profile is followed based on the threshold limit. However, if the **Hierarchical Approval** check box is not selected while defining a refund or write off request type, the approval is required only from the approval level where the total refund or write off amount falls within the threshold limit. Let us understand this with the help of some examples.

### **Example 1**

Refund Request Type	Approval Profile	Approval Hierarchy	Hierarchical Approval								
R1	Refund Analyst	<p><b>Credit Hierarchy</b></p> <table border="1"> <thead> <tr> <th>Threshold Amount</th> <th>To Do Role</th> </tr> </thead> <tbody> <tr> <td>\$500</td> <td>Senior Analyst</td> </tr> <tr> <td>\$750</td> <td>Manager</td> </tr> <tr> <td>\$1500</td> <td>Senior Manager</td> </tr> </tbody> </table>	Threshold Amount	To Do Role	\$500	Senior Analyst	\$750	Manager	\$1500	Senior Manager	Yes
Threshold Amount	To Do Role										
\$500	Senior Analyst										
\$750	Manager										
\$1500	Senior Manager										
R2	Refund Analyst	<p><b>Credit Hierarchy</b></p> <table border="1"> <thead> <tr> <th>Threshold Amount</th> <th>To Do Role</th> </tr> </thead> <tbody> <tr> <td>\$500</td> <td>Senior Analyst</td> </tr> <tr> <td>\$750</td> <td>Manager</td> </tr> <tr> <td>\$1500</td> <td>Senior Manager</td> </tr> </tbody> </table>	Threshold Amount	To Do Role	\$500	Senior Analyst	\$750	Manager	\$1500	Senior Manager	No
Threshold Amount	To Do Role										
\$500	Senior Analyst										
\$750	Manager										
\$1500	Senior Manager										

The following table indicates how the system will behave in different refund scenarios:

Refund Request	Refund Request Type	Total Refund Amount (\$)	Comments
RR1	R1	200	This refund request is automatically approved by the system because the total refund amount is less than \$500.
RR2	R1	750	<p>The To Do is sent for approval to the following users in the specified order:</p> <ol style="list-style-type: none"> <li>1. Users with the Senior Analyst To Do role</li> <li>2. Users with the Manager To Do role</li> </ol> <p>This is because the total refund amount is either equal to \$750 or less than \$1500 and hierarchical approval is required.</p>
RR3	R1	2000	<p>The To Do is sent for approval to the following users in the specified order:</p> <ol style="list-style-type: none"> <li>1. Users with the Senior Analyst To Do role</li> <li>2. Users with the Manager To Do role</li> <li>3. Users with the Senior Manager To Do role</li> </ol> <p>This is because the total refund amount is greater than \$1500 and hierarchical approval is required.</p>
RR4	R2	200	This refund request is automatically approved by the system because the total refund amount is less than \$500.

Refund Request	Refund Request Type	Total Refund Amount (\$)	Comments
RR5	R2	750	The To Do is sent for approval to users with the Manager To Do role. This is because the total refund amount is either equal to \$750 or less than \$1500 and hierarchical approval is not required.
RR6	R2	2000	The To Do is sent for approval to users with the Senior Manager To Do role. This is because the total refund amount is greater than \$1500 and hierarchical approval is not required.

**Example 2**

Write Off Request Type	Approval Profile	Approval Hierarchy	Hierarchical Approval								
W1	Write Off Analyst	<b>Debit Hierarchy</b>	Yes								
		<table border="1"> <thead> <tr> <th>Threshold Amount</th> <th>To Do Role</th> </tr> </thead> <tbody> <tr> <td>\$100</td> <td>Senior Analyst</td> </tr> <tr> <td>\$200</td> <td>Manager</td> </tr> <tr> <td>\$300</td> <td>Senior Manager</td> </tr> </tbody> </table>		Threshold Amount	To Do Role	\$100	Senior Analyst	\$200	Manager	\$300	Senior Manager
		Threshold Amount		To Do Role							
		\$100		Senior Analyst							
		\$200		Manager							
\$300	Senior Manager										
W2	Write Off Analyst	<b>Debit Hierarchy</b>	No								
		<table border="1"> <thead> <tr> <th>Threshold Amount</th> <th>To Do Role</th> </tr> </thead> <tbody> <tr> <td>\$100</td> <td>Senior Analyst</td> </tr> <tr> <td>\$200</td> <td>Manager</td> </tr> <tr> <td>\$300</td> <td>Senior Manager</td> </tr> </tbody> </table>		Threshold Amount	To Do Role	\$100	Senior Analyst	\$200	Manager	\$300	Senior Manager
		Threshold Amount		To Do Role							
		\$100		Senior Analyst							
		\$200		Manager							
\$300	Senior Manager										

The following table indicates how the system will behave in different write off scenarios:

Write Off Request	Write Off Request Type	Total Write Off Amount (\$)	Comments
WO1	W1	90	This write off request is automatically approved by the system because the total write off amount is less than \$100.
WO2	W1	250	<p>The To Do is sent for approval to the following users in the specified order:</p> <ol style="list-style-type: none"> <li>Users with the Senior Analyst To Do role</li> <li>Users with the Manager To Do role</li> </ol> <p>This is because the total write off amount is either equal to \$200 or less than \$300 and hierarchical approval is required.</p>



Write Off Request	Write Off Request Type	Total Write Off Amount (\$)	Comments
WO3	W1	500	<p>The To Do is sent for approval to the following users in the specified order:</p> <ol style="list-style-type: none"> <li>1. Users with the Senior Analyst To Do role</li> <li>2. Users with the Manager To Do role</li> <li>3. Users with the Senior Manager To Do role</li> </ol> <p>This is because the total write off amount is greater than \$300 and hierarchical approval is required.</p>
WO4	W2	90	This write off request is automatically approved by the system because the total write off amount is less than \$100.
WO5	W2	250	The To Do is sent for approval to users with the Manager To Do role. This is because the total write off amount is either equal to \$200 or less than \$300 and hierarchical approval is not required.
WO6	W2	500	The To Do is sent for approval to users with the Senior Manager To Do role. This is because the total write off amount is greater than \$300 and hierarchical approval is not required.

The **Refund/Write Off Request Type** screen allows you to define, edit, delete, and copy a refund and write off request type. This screen consists of the following zones:

- [Refund/Write Off Request Type List](#) on page 1407
- [Refund/Write Off Request Type](#) on page 1408

## Refund/Write Off Request Type List

The **Refund/Write Off Request Type List** zone lists refund and write off request types that are already defined in the system. It contains the following columns:

Column Name	Column Description
Refund/Write Off Request Type	Displays the refund or write off request type.
Description	Displays the description of the refund or write off request type.
Edit	On clicking the <b>Edit</b> (  ) icon, the <b>Refund/Write Off Request Type</b> screen appears where you can edit the details of the refund and write off request type.
Duplicate	On clicking the <b>Duplicate</b> (  ) icon, the <b>Refund/Write Off Request Type</b> screen appears where you can define a refund and write off request type using an existing refund and write off request type.
Delete	<p>On clicking the <b>Delete</b> () icon, you can delete the refund or write off request type.</p> <p><b>Note:</b> You can delete a refund or write off request type only when you have not created a refund or write off request using the refund or write off request type.</p>

On clicking the **Broadcast**  icon corresponding to refund or write off request type, the **Refund/Write Off Request Type** zone appears with the details of the respective refund or write off request type.

### Related Topics

For more information on...	See...
How to define a refund or write off request type	<a href="#">Defining a Refund or Write Off Request Type</a> on page 1410
How to edit a refund or write off request type	<a href="#">Editing a Refund or Write Off Request Type</a> on page 1414
How to copy a refund or write off request type	<a href="#">Copying a Refund or Write Off Request Type</a> on page 1418
How to delete a refund or write off request type	<a href="#">Deleting a Refund or Write Off Request Type</a> on page 1421
How to view the details of a refund or write off request type	<a href="#">Viewing the Refund or Write Off Request Type Details</a> on page 1422

## Refund/Write Off Request Type

The **Refund/Write Off Request Type** zone displays the details of the refund or write off request type. This zone consists of the following sections:

- **Main** — This section provides basic information about the refund or write off request type. It contains the following fields:

Field Name	Field Description
Refund/Write Off Request Type	Displays the refund or write off request type.
Refund/Write Off Request Business Object	Indicates the business object that will be used to create the refund or write off request.  <b>Note:</b> It has a link. On clicking the link, the <b>Business Object</b> screen appears with the details of the respective business object.
Description	Displays the description of the refund or write off request type.
Detailed Description	Displays additional information about the refund or write off request type.
Status	Indicates the status of the refund or write off request type. The valid values are: <ul style="list-style-type: none"> <li>• Active</li> <li>• Inactive</li> </ul>
Action	Indicates whether the request type is created for refund or write off. The valid values are: <ul style="list-style-type: none"> <li>• Refund</li> <li>• Write Off</li> </ul>
Minimum Refund Amount	Displays the minimum refund amount.  <b>Note:</b> This field appears only when the <b>Action</b> field is set to <b>Refund</b> .



Field Name	Field Description
Write Up Adjustment Type	Indicates the adjustment type using which the write up adjustment must be created when the total refund amount is less than the minimum refund amount.  <b>Note:</b> This field appears only when the <b>Action</b> field is set to <b>Refund</b> .
Approval Required	Indicates whether approval is required while creating the refund or write off adjustments using the refund or write off request type.
Approval Profile	Indicates the approval profile which must be used to define approval hierarchy for the refund or write off request type.  <b>Note:</b> This field appears only when the <b>Approval Required</b> check box is selected. It has a link. On clicking the link, the <b>Approval Profile</b> screen appears with the details of the respective approval profile.
Hierarchical Approval	Indicates whether multi-level or single approval is required while creating the refund or write off adjustments using the refund or write off request type.  <b>Note:</b> This field appears only when the <b>Approval Required</b> check box is selected.
Adjustment Type	Indicates the adjustment type using which the refund or write off adjustments must be created.  <b>Note:</b> It has a link. On clicking the link, the <b>Adjustment Type</b> screen appears with the details of the respective adjustment type.

- **Characteristics** — This section lists the characteristics defined for the refund or write off request type. It contains the following columns:

Column Name	Column Description
Characteristic Type	Indicates the characteristic type.
Characteristic Value	Displays the value of the characteristic type.

- **Record Actions** — This section contains the following buttons:

Button Name	Button Description
Edit	Used to edit the details of the refund or write off request type.
Delete	Used to delete the refund or write off request type.  <b>Note:</b> You can delete a refund or write off request type only when you have not created a refund or write off request using the refund or write off request type.
Duplicate	Used to create a new refund or write off request type using an existing refund or write off request type.

- **Record Information** — This section contains the following fields:

Field Name	Field Description
Business Object	<p>Indicates the business object using which the refund or write off request type is created. In addition, a context menu appears corresponding to this field which helps in navigating to other screens in the application.</p> <p><b>Note:</b> It has a link. On clicking the link, the <b>Business Object</b> screen appears where you can view the details of the respective business object.</p>

By default, the **Refund/Write Off Request Type** zone does not appear in the **Refund/Write Off Request Type** screen. It appears only when you click the **Broadcast**  icon corresponding to the refund or write off request type in the **Refund/Write Off Request Type List** zone.

### Related Topics

For more information on...	See...
How to define a refund or write off request type	<a href="#">Defining a Refund or Write Off Request Type</a> on page 1410
How to edit a refund or write off request type	<a href="#">Editing a Refund or Write Off Request Type</a> on page 1414
How to copy a refund or write off request type	<a href="#">Copying a Refund or Write Off Request Type</a> on page 1418
How to delete a refund or write off request type	<a href="#">Deleting a Refund or Write Off Request Type</a> on page 1421
How to view the details of a refund or write off request type	<a href="#">Viewing the Refund or Write Off Request Type Details</a> on page 1422

## Defining a Refund or Write Off Request Type

### Prerequisites

To define a refund or write off request type, you should have:

- Refund or Write Off request business objects defined in the application
- Approval profiles defined in the application
- Adjustment types with and without A/P request type defined in the application

### Procedure

To define a refund or write off request type:

1. Click the **Admin** link in the **Application** toolbar.  
A list appears.
2. From the **Admin** menu, select **R** and then click **Refund/Write Off Request Type**.  
A sub-menu appears.
3. Click the **Add** option from the **Refund/Write Off Request Type** sub-menu.

The **Select Business Object** screen appears. It contains the following fields:

Field Name	Field Description	Mandatory (Yes or No)
Refund/Write Off Request Type Business Object	Used to indicate the business object that you want to use to create the refund or write off request type.	Yes

**Tip:** Alternatively, you can access the **Select Business Object** screen by clicking the **Add** button in the **Page Title** area of the **Refund/Write Off Request Type** screen.

**Note:** The **Select Business Object** screen appears only when there are multiple refund and write off request type business objects defined in the application. If there is only one refund and write off request type business object defined in the application, the **Refund/Write Off Request Type** screen appears.

4. Select the required refund and write off request type business object from the respective field.
5. Click **OK**.

The **Refund/Write Off Request Type** screen appears. It contains the following sections:

- **Main** - Used to specify basic details about the refund or write off request type.
- **Characteristics** - Used to define characteristics for the refund or write off request type.

The **Main** section contains the following fields:

Field Name	Field Description	Mandatory (Yes or No)
Refund/Write Off Request Type	Used to specify the refund or write off request type.	Yes
Business Object	Indicates the refund and write off request type business object used while defining the refund or write off request type.	Not applicable
Refund/Write Off Request Business Object	Used to indicate the business object that you want to use while creating the refund or write off request.	Yes
Description	Used to specify the description for the refund or write off request type.	Yes
Detailed Description	Used to specify additional information about the refund or write off request type.	No
Status	Used to indicate the status of the refund or write off request type. The valid values are: <ul style="list-style-type: none"> <li>• Active</li> <li>• Inactive</li> </ul> <div style="border: 1px solid black; padding: 5px; margin-top: 10px;"> <p><b>Note:</b> You cannot change the status of a refund or write off request type to <b>Inactive</b> if there are refund or write off requests which are created using the refund or write off request type and are currently in the <b>Draft</b> or <b>Approval In Progress</b> status.</p> </div>	Yes
Action	Used to indicate whether the request type is created for refund or write off. The valid values are: <ul style="list-style-type: none"> <li>• Refund</li> <li>• Write Off</li> </ul>	Yes

Field Name	Field Description	Mandatory (Yes or No)
Minimum Refund Amount	<p>Used to specify the minimum refund amount. This field is used to define tolerance limit for refund. If the total refund amount in a refund request is less than the minimum refund amount, the system creates a write up adjustment. However, if the total refund amount in a refund request is equal to or greater than the minimum refund amount, the system creates a refund adjustment.</p> <p><b>Note:</b> This field appears only when the <b>Action</b> field is set to <b>Refund</b>.</p>	Yes
Write Up Adjustment Type	<p>Used to indicate the adjustment type using which the write up adjustment must be created when the total refund amount is less than the minimum refund amount.</p> <p><b>Note:</b> This field appears only when the <b>Action</b> field is set to <b>Refund</b>. You can create write up adjustments only using those adjustment types where A/P request type is not defined.</p>	Yes
Approval Required	Used to indicate whether approval is required while creating the refund or write off adjustments using the refund or write off request type.	No
Approval Profile	<p>Used to indicate the approval profile which must be used to define approval hierarchy for the refund or write off request type.</p> <p><b>Note:</b> This field appears only when the <b>Approval Required</b> check box is selected.</p>	Yes (Conditional)  <b>Note:</b> This field is required when the <b>Approval Required</b> check box is selected.
Hierarchical Approval	<p>Used to indicate whether multi-level or single-level approval is required while creating the refund or write off adjustments using the refund or write off request type.</p> <p><b>Note:</b> This field appears only when the <b>Approval Required</b> check box is selected.</p>	No

Field Name	Field Description	Mandatory (Yes or No)
Refund Adjustment Type	<p>Used to indicate the adjustment type using which the refund adjustments must be created. This default adjustment type appears when you select the payments or credit bill line items for refund. You can then change the adjustment type, if required, while editing a refund request.</p> <div style="border: 1px solid black; padding: 5px;"> <p><b>Note:</b></p> <p>This field appears only when the <b>Action</b> field is set to <b>Refund</b>.</p> <p>The list includes only those adjustment types where A/P request type is defined.</p> </div>	Yes
Write Off Adjustment Type	<p>Used to indicate the adjustment type using which the write off adjustments must be created. This default adjustment type appears when you select the debit bill line items for write off. You can then change the adjustment type, if required, while editing a write off request.</p> <div style="border: 1px solid black; padding: 5px;"> <p><b>Note:</b></p> <p>This field appears only when the <b>Action</b> field is set to <b>Write Off</b>.</p> <p>You can create write off adjustments only using those adjustment types where A/P request type is not defined.</p> </div>	Yes

6. Enter the required details depending on whether you want to define refund or write off request type.

**Note:** You can search for an adjustment type by clicking the **Search**  icon corresponding to the respective field.

7. Define characteristics for the refund or write off request type, if required.
8. Click **Save**.

The refund or write off request type is defined.

#### Related Topics

For more information on...	See...
Refund/Write Off Request Type screen	<a href="#">Refund/Write Off Request Type</a> on page 1403
How to define characteristics for a refund or write off request type	<a href="#">Defining Characteristics for a Refund or Write Off Request Type</a> on page 1413

## Defining Characteristics for a Refund or Write Off Request Type

### Prerequisites

To define characteristics for a refund or write off request type, you should have:

- Characteristic types defined in the application (where the characteristic entity is set to **Refund Write Off Request Type**)

### **Procedure**

To define characteristics for a refund or write off request type:

1. Ensure that the **Characteristics** section is expanded when you are defining, editing, or copying a refund or write off request type.

The **Characteristics** section contains the following fields:

Field Name	Field Description	Mandatory (Yes or No)
Characteristic Type	Used to indicate the characteristic type. <b>Note:</b> The list includes only those characteristic types where the characteristic entity is set to <b>Refund Write Off Request Type</b> .	Yes (Conditional) <b>Note:</b> This field is required when you are defining a characteristic for the refund or write off request type.
Characteristic Value	Used to specify the value for the characteristic type. <b>Note:</b> On specifying the value for a predefined characteristic type, the description of the characteristic value appears corresponding to the <b>Characteristic Value</b> field.	Yes (Conditional) <b>Note:</b> This field is required when you are defining a characteristic for the refund or write off request type.

2. Enter the required details in the **Characteristics** section.

**Note:** If you select a predefined characteristic type, the **Search** () icon appears corresponding to the **Characteristic Value** field. On clicking the **Search** icon, you can search for a predefined characteristic value.

3. If you want to define more than one characteristic for the refund or write off request type, click the **Add** () icon and then repeat step 2.

**Note:** However, if you want to remove a characteristic from the refund or write off request type, click the **Delete** () icon corresponding to the characteristic.

### **Related Topics**

For more information on...	See...
How to define a refund or write off request type	<a href="#">Defining a Refund or Write Off Request Type</a> on page 1410
How to edit a refund or write off request type	<a href="#">Editing a Refund or Write Off Request Type</a> on page 1414
How to copy a refund or write off request type	<a href="#">Copying a Refund or Write Off Request Type</a> on page 1418

## **Editing a Refund or Write Off Request Type**

### **Prerequisites**

To edit a refund or write off request type, you should have:

- Refund or Write Off request business objects defined in the application

- Approval profiles defined in the application
- Adjustment types with and without A/P request type defined in the application

### Procedure

To edit a refund or write off request type:

1. Click the **Admin** link in the **Application** toolbar.  
A list appears.
2. From the **Admin** menu, select **R** and then click **Refund/Write Off Request Type**.  
A sub-menu appears.
3. Click the **Search** option from the **Refund/Write Off Request Type** sub-menu.  
The **Refund/Write Off Request Type** screen appears.
4. In the **Refund/Write Off Request Type List** zone, click the **Edit**  icon in the **Edit** column corresponding to the refund or write off request type whose details you want to edit.

The **Refund/Write Off Request Type** screen appears. It contains the following sections:

- **Main** - Used to specify basic details about the refund or write off request type.
- **Characteristics** - Used to define characteristics for the refund or write off request type.

The **Main** section contains the following fields:

Field Name	Field Description	Mandatory (Yes or No)
Refund/Write Off Request Type	Displays the refund or write off request type.	Not applicable
Business Object	Indicates the refund and write off request type business object used while defining the refund or write off request type.	Not applicable
Refund/Write Off Request Business Object	Used to indicate the business object that you want to use while creating the refund or write off request.	Yes
Description	Used to specify the description for the refund or write off request type.	Yes
Detailed Description	Used to specify additional information about the refund or write off request type.	No
Status	Used to indicate the status of the refund or write off request type. The valid values are: <ul style="list-style-type: none"> <li>• Active</li> <li>• Inactive</li> </ul> <div style="border: 1px solid black; padding: 5px; margin-top: 10px;"> <p><b>Note:</b> You cannot change the status of a refund or write off request type to <b>Inactive</b> if there are refund or write off requests which are created using the refund or write off request type and are currently in the <b>Draft</b> or <b>Approval In Progress</b> status.</p> </div>	Yes

Field Name	Field Description	Mandatory (Yes or No)
Action	<p>Indicates whether the request type is created for refund or write off. The valid values are:</p> <ul style="list-style-type: none"> <li>• Refund</li> <li>• Write Off</li> </ul>	Not applicable
Minimum Refund Amount	<p>Used to specify the minimum refund amount. This field is used to define tolerance limit for refund. If the total refund amount in a refund request is less than the minimum refund amount, the system creates a write up adjustment. However, if the total refund amount in a refund request is equal to or greater than the minimum refund amount, the system creates a refund adjustment.</p> <div style="border: 1px solid black; padding: 2px;"> <p><b>Note:</b> This field appears only when the <b>Action</b> field is set to <b>Refund</b>.</p> </div>	Yes
Write Up Adjustment Type	<p>Used to indicate the adjustment type using which the write up adjustment must be created when the total refund amount is less than the minimum refund amount.</p> <div style="border: 1px solid black; padding: 2px;"> <p><b>Note:</b> This field appears only when the <b>Action</b> field is set to <b>Refund</b>. You can create write up adjustments only using those adjustment types where A/P request type is not defined.</p> </div>	Yes
Approval Required	<p>Used to indicate whether approval is required while creating the refund or write off adjustments using the refund or write off request type.</p>	No
Approval Profile	<p>Used to indicate the approval profile which must be used to define approval hierarchy for the refund or write off request type.</p> <div style="border: 1px solid black; padding: 2px;"> <p><b>Note:</b> This field appears only when the <b>Approval Required</b> check box is selected.</p> </div>	<p>Yes (Conditional)</p> <div style="border: 1px solid black; padding: 2px;"> <p><b>Note:</b> This field is required when the <b>Approval Required</b> check box is selected.</p> </div>



Field Name	Field Description	Mandatory (Yes or No)
Hierarchical Approval	Used to indicate whether multi-level or single-level approval is required while creating the refund or write off adjustments using the refund or write off request type.  <b>Note:</b> This field appears only when the <b>Approval Required</b> check box is selected.	No
Refund Adjustment Type	Used to indicate the adjustment type using which the refund adjustments must be created. This default adjustment type appears when you select the payments or credit bill line items for refund. You can then change the adjustment type, if required, while editing a refund request.  <b>Note:</b> This field appears only when the <b>Action</b> field is set to <b>Refund</b> . The list includes only those adjustment types where A/P request type is defined.	Yes
Write Off Adjustment Type	Used to indicate the adjustment type using which the write off adjustments must be created. This default adjustment type appears when you select the debit bill line items for write off. You can then change the adjustment type, if required, while editing a write off request.  <b>Note:</b> This field appears only when the <b>Action</b> field is set to <b>Write Off</b> . You can create write off adjustments only using those adjustment types where A/P request type is not defined.	Yes

**Tip:** Alternatively, you can click the **Edit** button in the **Refund/Write Off Request Type** zone to edit the details of the refund or write off request type.

- Modify the required details in the **Main** section.

**Note:** You can search for an adjustment type by clicking the **Search**  icon corresponding to the respective field.

- Define, edit, or remove characteristics from the refund or write off request type, if required.
- Click **Save**.

The changes made to the refund or write off request type are saved.

**Related Topics**

For more information on...	See...
Refund/Write Off Request Type screen	<a href="#">Refund/Write Off Request Type</a> on page 1403
Refund/Write Off Request Type List zone	<a href="#">Refund/Write Off Request Type List</a> on page 1407
Refund/Write Off Request Type zone	<a href="#">Refund/Write Off Request Type</a> on page 1408
How to define characteristics for a refund or write off request type	<a href="#">Defining Characteristics for a Refund or Write Off Request Type</a> on page 1413

**Copying a Refund or Write Off Request Type**

Instead of creating a refund or write off request type from scratch, you can create a new refund or write off request type using an existing refund or write off request type. This is possible through copying a refund or write off request type. On copying a refund or write off request type, the details including the characteristics are copied to the new refund or write off request type. You can then edit the details, if required.

**Prerequisites**

To copy a refund or write off request type, you should have:

- Refund or Write Off request type (whose copy you want to create) defined in the application
- Refund or Write Off request business objects defined in the application
- Approval profiles defined in the application
- Adjustment types with and without A/P request type defined in the application

**Procedure**

To copy a refund or write off request type:

1. Click the **Admin** link in the **Application** toolbar.  
A list appears.
2. From the **Admin** menu, select **R** and then click **Refund/Write Off Request Type**.  
A sub-menu appears.
3. Click the **Search** option from the **Refund/Write Off Request Type** sub-menu.  
The **Refund/Write Off Request Type** screen appears.
4. In the **Refund/Write Off Request Type List** zone, click the **Duplicate** () icon in the **Duplicate** column corresponding to the refund or write off request type whose copy you want to create.

The **Refund/Write Off Request Type** screen appears. It contains the following sections:

- **Main** - Used to specify basic details about the refund or write off request type.
- **Characteristics** - Used to define characteristics for the refund or write off request type.

The **Main** section contains the following fields:

Field Name	Field Description	Mandatory (Yes or No)
Refund/Write Off Request Type	Used to specify the refund or write off request type.	Yes

Field Name	Field Description	Mandatory (Yes or No)
Business Object	Indicates the refund and write off request type business object used while defining the refund or write off request type.	Not applicable
Refund/Write Off Request Business Object	Used to indicate the business object that you want to use while creating the refund or write off request.	Yes
Description	Used to specify the description for the refund or write off request type.	Yes
Detailed Description	Used to specify additional information about the refund or write off request type.	No
Status	<p>Used to indicate the status of the refund or write off request type. The valid values are:</p> <ul style="list-style-type: none"> <li>• Active</li> <li>• Inactive</li> </ul> <div style="border: 1px solid black; padding: 5px; margin-top: 10px;"> <p><b>Note:</b> You cannot change the status of a refund or write off request type to <b>Inactive</b> if there are refund or write off requests which are created using the refund or write off request type and are currently in the <b>Draft</b> or <b>Approval In Progress</b> status.</p> </div>	Yes
Action	<p>Used to indicate whether the request type is created for refund or write off. The valid values are:</p> <ul style="list-style-type: none"> <li>• Refund</li> <li>• Write Off</li> </ul>	Yes
Minimum Refund Amount	<p>Used to specify the minimum refund amount. This field is used to define tolerance limit for refund. If the total refund amount in a refund request is less than the minimum refund amount, the system creates a write up adjustment. However, if the total refund amount in a refund request is equal to or greater than the minimum refund amount, the system creates a refund adjustment.</p> <div style="border: 1px solid black; padding: 5px; margin-top: 10px;"> <p><b>Note:</b> This field appears only when the <b>Action</b> field is set to <b>Refund</b>.</p> </div>	Yes

Field Name	Field Description	Mandatory (Yes or No)
Write Up Adjustment Type	<p>Used to indicate the adjustment type using which the write up adjustment must be created when the total refund amount is less than the minimum refund amount.</p> <div data-bbox="743 386 1167 644" style="border: 1px solid black; padding: 5px;"> <p><b>Note:</b> This field appears only when the <b>Action</b> field is set to <b>Refund</b>. You can create write up adjustments only using those adjustment types where A/P request type is not defined.</p> </div>	Yes
Approval Required	Used to indicate whether approval is required while creating the refund or write off adjustments using the refund or write off request type.	No
Approval Profile	<p>Used to indicate the approval profile which must be used to define approval hierarchy for the refund or write off request type.</p> <div data-bbox="743 961 1167 1073" style="border: 1px solid black; padding: 5px;"> <p><b>Note:</b> This field appears only when the <b>Approval Required</b> check box is selected.</p> </div>	Yes (Conditional) <div data-bbox="1192 867 1463 1010" style="border: 1px solid black; padding: 5px; margin-top: 10px;"> <p><b>Note:</b> This field is required when the <b>Approval Required</b> check box is selected.</p> </div>
Hierarchical Approval	<p>Used to indicate whether multi-level or single-level approval is required while creating the refund or write off adjustments using the refund or write off request type.</p> <div data-bbox="743 1276 1167 1388" style="border: 1px solid black; padding: 5px;"> <p><b>Note:</b> This field appears only when the <b>Approval Required</b> check box is selected.</p> </div>	No
Refund Adjustment Type	<p>Used to indicate the adjustment type using which the refund adjustments must be created. This default adjustment type appears when you select the payments or credit bill line items for refund. You can then change the adjustment type, if required, while editing a refund request.</p> <div data-bbox="743 1696 1167 1913" style="border: 1px solid black; padding: 5px;"> <p><b>Note:</b> This field appears only when the <b>Action</b> field is set to <b>Refund</b>. The list includes only those adjustment types where A/P request type is defined.</p> </div>	Yes

Field Name	Field Description	Mandatory (Yes or No)
Write Off Adjustment Type	Used to indicate the adjustment type using which the write off adjustments must be created. This default adjustment type appears when you select the debit bill line items for write off. You can then change the adjustment type, if required, while editing a write off request.  <div style="border: 1px solid black; padding: 5px;"> <p><b>Note:</b> This field appears only when the <b>Action</b> field is set to <b>Write Off</b>. You can create write off adjustments only using those adjustment types where A/P request type is not defined.</p> </div>	Yes

**Tip:** Alternatively, you can click the **Duplicate** button in the **Refund/Write Off Request Type** zone to create a copy of the refund or write off request type.

- Enter the required details in the **Main** section.

**Note:** You can search for an adjustment type by clicking the **Search**  icon corresponding to the respective field.

- Define, edit, or remove characteristics from the refund or write off request type, if required.
- Click **Save**.

The new refund or write off request type is defined.

### Related Topics

For more information on...	See...
<b>Refund/Write Off Request Type</b> screen	<a href="#">Refund/Write Off Request Type</a> on page 1403
<b>Refund/Write Off Request Type List</b> zone	<a href="#">Refund/Write Off Request Type List</a> on page 1407
<b>Refund/Write Off Request Type</b> zone	<a href="#">Refund/Write Off Request Type</a> on page 1408
How to define characteristics for a refund or write off request type	<a href="#">Defining Characteristics for a Refund or Write Off Request Type</a> on page 1413

## Deleting a Refund or Write Off Request Type

### Procedure

To delete a refund or write off request type:

- Click the **Admin** link in the **Application** toolbar.  
A list appears.
- From the **Admin** menu, select **R** and then click **Refund/Write Off Request Type**.  
A sub-menu appears.
- Click the **Search** option from the **Refund/Write Off Request Type** sub-menu.  
The **Refund/Write Off Request Type** screen appears.

- In the **Refund/Write Off Request Type List** zone, click the **Delete** () icon in the **Delete** column corresponding to the refund or write off request type that you want to delete.

A message appears confirming whether you want to delete the refund or write off request type.

**Note:** You can delete a refund or write off request type only when you have not defined a refund or write off request using the refund or write off request type.

**Tip:** Alternatively, you can click the **Delete** button in the **Refund/Write Off Request Type** zone to delete the refund or write off request type.

- Click **OK**.

The refund or write off request type is deleted.

### Related Topics

For more information on...	See...
<b>Refund/Write Off Request Type</b> screen	<a href="#">Refund/Write Off Request Type</a> on page 1403
<b>Refund/Write Off Request Type List</b> zone	<a href="#">Refund/Write Off Request Type List</a> on page 1407
<b>Refund/Write Off Request Type</b> zone	<a href="#">Refund/Write Off Request Type</a> on page 1408

## Viewing the Refund or Write Off Request Type Details

### Procedure

To view the details of a refund or write off request type:

- Click the **Admin** link in the **Application** toolbar.  
A list appears.
- From the **Admin** menu, select **R** and then click **Refund/Write Off Request Type**.  
A sub-menu appears.
- Click the **Search** option from the **Refund/Write Off Request Type** sub-menu.  
The **Refund/Write Off Request Type** screen appears.
- In the **Refund/Write Off Request Type List** zone, click the **Broadcast** () icon corresponding to the refund or write off request type whose details you want to view.  
The **Refund/Write Off Request Type** zone appears.
- View the details of the refund or write off request type in the **Refund/Write Off Request Type** zone.

### Related Topics

For more information on...	See...
<b>Refund/Write Off Request Type</b> screen	<a href="#">Refund/Write Off Request Type</a> on page 1403
<b>Refund/Write Off Request Type List</b> zone	<a href="#">Refund/Write Off Request Type List</a> on page 1407
<b>Refund/Write Off Request Type</b> zone	<a href="#">Refund/Write Off Request Type</a> on page 1408

## Refund/Write Off Request

The **Refund/Write Off Request** screen allows you to search for a refund and write off request using various search criteria. It also allows you to create a refund and write off requests. Through this screen, you can navigate to the following screens:

- [Refund Request](#) on page 1434
- [Write Off Request](#) on page 1467

This screen consists of the following zones:

- [Search Refund/Write Off Request](#) on page 1423

### Search Refund/Write Off Request

The **Search Refund/Write Off Request** zone allows you to search for refund and write off requests using various search criteria. This zone contains the following two sections:

- **Search Criteria** — The **Search Criteria** section contains the following fields:

Field Name	Field Description	Mandatory (Yes or No)
Search By	<p>Used to indicate whether you want to search for a refund or write off request using request, payment, or bill details. The valid values are:</p> <ul style="list-style-type: none"> <li>• <b>Request Details</b> — Used when you want to search for refund and/or write off requests.</li> <li>• <b>Payment Details</b> — Used when you want to search for refund requests.</li> <li>• <b>Bill Details</b> — Used when you want to search for refund and/or write off requests.</li> </ul> <p><b>Note:</b> By default, the <b>Request Details</b> option is selected.</p>	Yes
Action	<p>Used to indicate whether you want to search for refund or write off requests. The valid values are:</p> <ul style="list-style-type: none"> <li>• Refund</li> <li>• Write Off</li> </ul> <p><b>Note:</b> This field appears only when you select the <b>Request Details</b> or <b>Bill Details</b> option from the <b>Search By</b> list.</p>	No

Field Name	Field Description	Mandatory (Yes or No)
Refund/Write Off Request Type	<p>Used to search refund or write off requests which are created using a particular refund or write off request type.</p> <div data-bbox="597 323 1125 585" style="border: 1px solid black; padding: 5px;"> <p><b>Note:</b></p> <p>This field appears only when you select the <b>Request Details</b> option from the <b>Search By</b> list.</p> <p>The refund or write off request types are listed only when you set the <b>Action</b> field to either <b>Refund</b> or <b>Write Off</b>.</p> </div>	No
Status	<p>Used to search refund or write off requests with a particular status. The valid values are:</p> <ul style="list-style-type: none"> <li>• Approval In Progress</li> <li>• Cancelled</li> <li>• Draft</li> <li>• Processed</li> <li>• Rejected</li> <li>• Voided</li> </ul> <div data-bbox="597 974 1125 1236" style="border: 1px solid black; padding: 5px;"> <p><b>Note:</b></p> <p>This field appears only when you select the <b>Request Details</b> option from the <b>Search By</b> list.</p> <p>The <b>Voided</b> status is applicable while searching for refund requests and the <b>Cancelled</b> status is applicable while searching for write off requests.</p> </div>	No
User ID	<p>Used to search refund or write off requests which are created by a particular user.</p> <div data-bbox="597 1352 1125 1425" style="border: 1px solid black; padding: 5px;"> <p><b>Note:</b> This field appears only when you select the <b>Request Details</b> option from the <b>Search By</b> list.</p> </div>	No
Created From	<p>Used to search refund or write off requests which are created from a particular date onwards.</p> <div data-bbox="597 1541 1125 1614" style="border: 1px solid black; padding: 5px;"> <p><b>Note:</b> This field appears only when you select the <b>Request Details</b> option from the <b>Search By</b> list.</p> </div>	No
To	<p>Used to search refund or write off requests which are created till a particular date.</p> <div data-bbox="597 1730 1125 1908" style="border: 1px solid black; padding: 5px;"> <p><b>Note:</b></p> <p>By default, the current date appears in this field.</p> <p>This field appears only when you select the <b>Request Details</b> option from the <b>Search By</b> list.</p> </div>	No



Field Name	Field Description	Mandatory (Yes or No)
Refund/Write Off Request ID	Used to search a particular refund or write off request.  <b>Note:</b> This field appears only when you select the <b>Request Details</b> option from the <b>Search By</b> list.	No
Payment Event ID	Used to search refund requests which includes a particular payment event for refund.  <b>Note:</b> This field appears only when you select the <b>Payment Details</b> option from the <b>Search By</b> list.	No
Payor Account ID	Used to search refund requests which are created for a particular payor account.  <b>Note:</b> This field appears only when you select the <b>Payment Details</b> option from the <b>Search By</b> list.	No
Payor Name	Used to search refund requests which are created for a particular payor.  <b>Note:</b> This field appears only when you select the <b>Payment Details</b> option from the <b>Search By</b> list.	No
Payment Date	Used to search refund requests which includes payments made on a particular date.  <b>Note:</b> This field appears only when you select the <b>Payment Details</b> option from the <b>Search By</b> list.	No
MICR ID	Used to search refund requests which includes payments made with a particular MICR code.  <b>Note:</b> This field appears only when you select the <b>Payment Details</b> option from the <b>Search By</b> list.	No
Check Number	Used to search refund request which includes payment made through a particular check.  <b>Note:</b> This field appears only when you select the <b>Payment Details</b> option from the <b>Search By</b> list.	No
Bill ID	Used to search refund or write off requests which includes bill segments or adjustments of a particular bill.  <b>Note:</b> This field appears only when you select the <b>Bill Details</b> option from the <b>Search By</b> list.	No

Field Name	Field Description	Mandatory (Yes or No)
Bill Date From	Used to search refund or write off requests which includes bill segments or adjustments of bills which are created from a particular date onwards.  <b>Note:</b> This field appears only when you select the <b>Bill Details</b> option from the <b>Search By</b> list.	No
To	Used to search refund or write off requests which includes bill segments or adjustments of bills which are created till a particular date.  <b>Note:</b> By default, the current date appears in this field. This field appears only when you select the <b>Bill Details</b> option from the <b>Search By</b> list.	No

**Note:** You must specify at least one search criterion while searching for a refund or write off request.

- **Search Results** — On clicking the **Search** button, the search results appear based on the specified search criteria. The **Search Results** section contains the following columns:

Column Name	Column Description
Create Date/Time	Displays the date and time when the refund or write off request is created.
Refund/Write Off Request Information	Displays information about the refund or write off request.  <b>Note:</b> It has a link. On clicking the link, the <b>Refund Request</b> or <b>Write Off Request</b> screen appears depending on whether the request is for refund or write off.
Status	Indicates the status of the refund or write off request.
Action	Indicates whether the request is created for refund or write off. The valid values are: <ul style="list-style-type: none"> <li>• Refund</li> <li>• Write Off</li> </ul> <b>Note:</b> This column appears only when you select the <b>Request Details</b> or <b>Bill Details</b> option from the <b>Search By</b> list.
Refund/Write Off Amount	Displays the total refund or write off amount.  <b>Note:</b> This column appears only when you select the <b>Request Details</b> or <b>Bill Details</b> option from the <b>Search By</b> list.
Refund Amount	Displays the total refund amount.  <b>Note:</b> This column appears only when you select the <b>Payment Details</b> option from the <b>Search By</b> list.

Column Name	Column Description
Account Information	Displays additional information about the account for which the refund or write off request is created.  <b>Note:</b> It has a link. On clicking the link, the <b>Account</b> screen appears with the details of the respective account.
Created By	Indicates the user who has created the refund or write off request.

### Related Topics

For more information on...	See...
How to search for a refund or write off request	<a href="#">Searching for a Refund or Write Off Request</a> on page 1427
How to view the details of a refund request	<a href="#">Viewing the Refund Request Details</a> on page 1433
How to view the details of a write off request	<a href="#">Viewing the Write Off Request Details</a> on page 1433
How to create a refund request	<a href="#">Creating a Refund Request</a> on page 1428
How to create a write off request	<a href="#">Creating a Write Off Request</a> on page 1430

## Searching for a Refund or Write Off Request

### Prerequisites

To search for a refund or write off request, you should have:

- Refund or Write Off request types defined in the application

### Procedure

To search for a refund or write off request:

1. Click the **Menu** link in the **Application** toolbar.  
A list appears.
2. From the **Main** menu, select **Financial** and then click **Refund/Write Off Request**.  
A sub-menu appears.
3. Click the **Search** option from the **Refund/Write Off Request** sub-menu.  
The **Refund/Write Off Request** screen appears.
4. Enter the search criteria in the **Search Refund/Write Off Request** zone depending on whether you want to search for a refund or write off request.

**Note:** ORMB search engine supports wildcard search, where you can substitute the percentage (%) symbol as a stand in for any word or letter in a search criteria. You can use the '%' wildcard character in all input fields except the date and ID fields. The '%' wildcard character is suffixed automatically at the end of the partial search criteria. Therefore, you may or may not specify the wildcard character at the end of the partial search criteria. However, you have to prefix the wildcard character manually wherever required.

5. Click **Search**.

A list of refund or write off requests that meet the search criteria appears in the **Search Results** section.

### Related Topics

For more information on...	See...
Refund/Write Off Request screen	<a href="#">Refund/Write Off Request</a> on page 1423
Search Refund/Write Off Request zone	<a href="#">Search Refund/Write Off Request</a> on page 1423

## Creating a Refund Request

### Prerequisites

To create a refund request, you should have:

- Refund request types defined in the application

### Procedure

To create a refund request:

1. Do either of the following:

If you want to...	Then...
Define a refund request from the <b>Account Receivable Central</b> screen	<ol style="list-style-type: none"> <li>1. Click the <b>Main</b> link in the <b>Application</b> toolbar. A list appears.</li> <li>2. From the <b>Main</b> menu, select <b>Financial</b> and then click <b>Account Receivable Central</b>.</li> <li>3. Search for the bill in the <b>Account Receivable Central</b> screen.</li> <li>4. In the <b>Search Results</b> section, select the required bill and then click <b>Refund</b>.</li> </ol> <div style="border: 1px solid black; padding: 5px; margin-top: 10px;"> <p><b>Note:</b> Only one bill at a time is allowed to select for <b>Refund Request</b> from the <b>Account Receivable Central</b> screen.</p> </div>
Define a refund request from the <b>Refund Request</b> screen	<ol style="list-style-type: none"> <li>1. Click the <b>Main</b> link in the <b>Application</b> toolbar. A list appears.</li> <li>2. From the <b>Main</b> menu, select <b>Financial</b> and then click <b>Refund/Write Off Request</b>.  A sub-menu appears.</li> <li>3. Click the <b>Add</b> option from the <b>Refund/Write Off Request</b> sub-menu.</li> </ol>

The **Select Request Type** screen appears. It contains the following fields:

Field Name	Field Description	Mandatory (Yes or No)
Action	<p>Displays the type of request (refund or write off) to be created.</p> <p><b>Note:</b> This field is pre-populated if the refund request is created from the <b>Account Receivable Central</b> screen. This field is editable if the refund request is created from the <b>Refund/Write Off Request</b> screen.</p>	Not applicable
Refund/Write Off Request Type	<p>Used to indicate the request type using which you want to create the refund or write off request.</p> <p><b>Note:</b> The refund request types are listed when you set the <b>Action</b> field to <b>Refund</b> and the write off request types are listed when you set the <b>Action</b> field to <b>Write Off</b>.</p>	Yes
Account	<p>Used to indicate the account for which you want to create the refund or write off request.</p> <p><b>Note:</b> This field is pre-populated if the refund request is created from the <b>Account Receivable Central</b> screen. This field is editable if the refund request is created from the <b>Refund/Write Off Request</b> screen. You can search for an account by clicking the <b>Search</b>  icon corresponding to the respective field.</p>	Yes

**Tip:**  
Alternatively, you can access the **Select Request Type** screen:

- By clicking the **Add** button in the **Page Title** area of **Refund/Write Off Request** screen.
- By selecting the payment which you want to refund in the **Payment Event Summary** screen and then clicking the **Refund** button. Note that the system will allow you to refund only those payments which are in the **Frozen** status and matched against the suspense or excess credit contract.

2. Select the required refund request type from the respective field.
3. Click **Save**.

The refund request is defined and the status of the refund request is set to **Draft**. The **Refund Request** screen appears where you can view the details of the refund request. It contains the following tabs:

**Note:** The refund request can be created only for bill with outstanding amount lesser than zero.

- **Main** – Displays information about the refund request. It contains the following zones:
    - **Refund Request** – Displays the details of the refund request.
    - **Refund Details** – Lists the entities, such as payment events, payments, and/or credit bill line items (such as credit bill segments and adjustments), of the account which must be refunded.
  - **Payments** — Used to search payment events or individual payments that you want to refund. This tab appears only when the refund request is in the **Draft** status.
  - **Bills** — Used to search bills with credit line items, such as credit bill segments and adjustments, that you want to refund. This tab appears only when the refund request is in the **Draft** status.
  - **Log** – Lists the complete trail of actions performed on the refund request.
4. Add payment events, payments, or credit bill line items that you want to refund.
  5. Edit the refund amount of each entity, if required.
  6. Define characteristics for the refund request, if required.
  7. Override the address if you want to sent the refund to an address other than the account’s main customer address.

### Related Topics

For more information on...	See...
<b>Refund Request</b> screen	<a href="#">Refund Request</a> on page 1434
<b>Account Receivable Central</b> screen	<a href="#">Account Receivable Central</a> on page 1236
How to add a payment event to the refund request	<a href="#">Adding a Payment Event to the Refund Request</a> on page 1448
How to add a payment to the refund request	<a href="#">Adding a Payment to the Refund Request</a> on page 1449
How to add a credit bill line item to the refund request	<a href="#">Adding a Credit Bill Line Item to the Refund Request</a> on page 1451
How to edit a refund request	<a href="#">Editing a Refund Request</a> on page 1453
How to define characteristics for a refund request	<a href="#">Defining Characteristics for a Refund Request</a> on page 1447

## Creating a Write Off Request

### Prerequisites

To create a write off request, you should have:

- Write off request types defined in the application

### Procedure

To create a write off request:

1. Do either of the following:

If you want to...	Then...
Define a write off request from the <b>Account Receivable Central</b> screen	<ol style="list-style-type: none"> <li>1. Click the <b>Main</b> link in the <b>Application</b> toolbar. A list appears.</li> </ol>

If you want to...	Then...
	<ol style="list-style-type: none"> <li>2. From the <b>Main</b> menu, select <b>Financial</b> and then click <b>Account Receivable Central</b>.</li> <li>3. Search for the bill in the <b>Account Receivable Central</b> screen.</li> <li>4. In the <b>Search Results</b> section, select the required bill and then click <b>Write Off</b>.</li> </ol> <div style="border: 1px solid black; padding: 5px; margin-top: 10px;"> <p><b>Note:</b> Only one bill at a time is allowed to select for <b>Write Off Request</b> from the <b>Account Receivable Central</b> screen.</p> </div>
Define a write off request from the <b>Write Off Request</b> screen	<ol style="list-style-type: none"> <li>1. Click the <b>Main</b> link in the <b>Application</b> toolbar. A list appears.</li> <li>2. From the <b>Main</b> menu, select <b>Financial</b> and then click <b>Refund/Write Off Request</b>. A sub-menu appears.</li> <li>3. Click the <b>Add</b> option from the <b>Refund/Write Off Request</b> sub-menu.</li> </ol>

The **Select Request Type** screen appears. It contains the following fields:

Field Name	Field Description	Mandatory (Yes or No)
Action	<p>Displays the type of request (refund or write off) to be created.</p> <div style="border: 1px solid black; padding: 5px; margin-top: 10px;"> <p><b>Note:</b> This field is pre-populated if the write off request is created from the <b>Account Receivable Central</b> screen. This field is editable if the write off request is created from the <b>Refund/Write Off Request</b> screen.</p> </div>	Yes
Refund/Write Off Request Type	<p>Used to indicate the request type using which you want to create the refund or write off request.</p> <div style="border: 1px solid black; padding: 5px; margin-top: 10px;"> <p><b>Note:</b> The refund request types are listed when you set the <b>Action</b> field to <b>Refund</b> and the write off request types are listed when you set the <b>Action</b> field to <b>Write Off</b>.</p> </div>	Yes

Field Name	Field Description	Mandatory (Yes or No)
Account	<p>Used to indicate the account for which you want to create the refund or write off request.</p> <p><b>Note:</b></p> <p>This field is pre-populated if the write off request is created from the <b>Account Receivable Central</b> screen.</p> <p>This field is editable if the write off request is created from the <b>Refund/Write Off Request</b> screen.</p> <p>You can search for an account by clicking the <b>Search</b>  icon corresponding to the respective field.</p>	Yes

**Tip:** Alternatively, you can access the **Select Request Type** screen by clicking the **Add** button in the **Page Title** area of the **Refund/Write Off Request** screen.

2. Select the required write off request type and account from the respective fields.
3. Click **Save**.

The write off request is defined and the status of the write off request is set to **Draft**. The **Write Off Request** screen appears with the details of the write off request. It contains the following tabs:

**Note:** The write off request can be created only for bill with outstanding amount greater than zero.

- **Main** – Displays information about the write off request. It contains the following zones:
    - **Write Off Request** – Displays the details of the write off request.
    - **Write Off Details** – Lists the debit bill line items (such as debit bill segments and adjustments) of the account which must be written off.
  - **Bills** — Used to search bills with debit line items, such as debit bill segments and adjustments, that you want to write off. This tab appears only when the write off request is in the **Draft** status.
  - **Log** – Lists the complete trail of actions performed on the write off request.
4. Add debit bill line items that you want to write off.
  5. Edit the write off amount of each entity, if required.
  6. Define characteristics for the write off request, if required.

### **Related Topics**

For more information on...	See...
<b>Write Off Request</b> screen	<a href="#">Write Off Request</a> on page 1467
<b>Account Receivable Central</b> screen	<a href="#">Account Receivable Central</a> on page 1236
How to add a debit bill line item to the write off request	<a href="#">Adding a Debit Bill Line Item to the Write Off Request</a> on page 1480
How to edit a write off request	<a href="#">Editing a Write Off Request</a> on page 1481
How to define characteristics for a write off request	<a href="#">Defining Characteristics for a Write Off Request</a> on page 1477



## Viewing the Refund Request Details

### Procedure

To view the details of a refund request:

1. Search for the refund request in the **Refund/Write Off Request** screen.
2. In the **Search Results** section, click the link in the **Refund/Write Off Request Information** column corresponding to the refund request whose details you want to view.

The **Refund Request** screen appears. It consists of the following tabs:

- **Main** – Displays information about the refund request. It contains the following zones:
    - **Refund Request** – Displays the details of the refund request.
    - **Refund Details** – Lists the entities, such as payment events, payments, and/or credit bill line items (such as credit bill segments and adjustments), of the account which must be refunded.
  - **Payments** — Used to search payment events or individual payments that you want to refund. This tab appears only when the refund request is in the **Draft** status.
  - **Bills** — Used to search bills with credit line items, such as credit bill segments and adjustments, that you want to refund. This tab appears only when the refund request is in the **Draft** status.
  - **Log** – Lists the complete trail of actions performed on the refund request.
3. View the details of the refund request in the **Refund Request** zone.
  4. View the entities (such as payment events, payments, or credit bill line items) which must be refunded in the **Refund Details** zone.

### Related Topics

For more information on...	See...
<b>Refund Request</b> screen	<a href="#">Refund Request</a> on page 1434
<b>Refund Request</b> zone	<a href="#">Refund Request</a> on page 1435
<b>Refund Details</b> zone	<a href="#">Refund Details</a> on page 1437
How to search for a refund request	<a href="#">Searching for a Refund or Write Off Request</a> on page 1427

## Viewing the Write Off Request Details

### Procedure

To view the details of a write off request:

1. Search for the write off request in the **Refund/Write Off Request** screen.
2. In the **Search Results** section, click the link in the **Refund/Write Off Request Information** column corresponding to the write off request whose details you want to view.

The **Write Off Request** screen appears. It consists of the following tabs:

- **Main** – Displays information about the write off request. It contains the following zones:
  - **Write Off Request** – Displays the details of the write off request.

- **Write Off Details** – Lists the debit bill line items, such as debit bill segments and adjustments, of the account which must be written off.
  - **Bills** — Used to search bills with debit line items, such as debit bill segments and adjustments, that you want to write off. This tab appears only when the write off request is in the **Draft** status.
  - **Log** – Lists the complete trail of actions performed on the write off request.
3. View the details of the write off request in the **Write Off Request** zone.
  4. View the entities (such as debit bill segments and adjustments) which must be written off in the **Write Off Details** zone.

### Related Topics

For more information on...	See...
<b>Write Off Request</b> screen	<a href="#">Write Off Request</a> on page 1467
<b>Write Off Request</b> zone	<a href="#">Write Off Request</a> on page 1468
<b>Write Off Details</b> zone	<a href="#">Write Off Details</a> on page 1470
How to search for a write off request	<a href="#">Searching for a Refund or Write Off Request</a> on page 1427

## Refund Request

Once you create a refund request, the **Refund Request** screen allows you to:

- Edit and delete a refund request
- View the details of a refund request
- Submit a refund request for approval
- Approve or reject a refund request
- View the log of a refund request
- Add a log entry for a refund request
- Void a refund request

This screen consists of the following tabs:

- **Main** – Displays information about the refund request. It contains the following zones:
  - **Refund Request** – Displays the details of the refund request.
  - **Refund Details** – Lists the entities, such as payment events, payments, and/or credit bill line items (such as credit bill segments and adjustments), of the account which must be refunded.
  - **Bill Line Items** — Displays the details of the bill which must be refunded.

**Note:** This zone appears when you click the Broadcast  icon corresponding to the entity type as **Bill** in the **Refund Details** zone.

- **Bills** — Used to search bills with credit line items, such as credit bill segments and adjustments, that you want to refund. It contains the following zones:
  - **Search Bills** — Lists completed bills of the account which are either with credit balance or have one or more credit line items, such as bill segments and adjustments. You can filter the bills using various search criteria.

- **Bill Line Items** — Lists the debit and credit bill segments and adjustments of the bill.

This tab appears only when the refund request is in the **Draft** status.

- **Payments** — Used to search payment events or individual payments that you want to refund. It contains the following zones:
  - **Search Payment Event** — Lists the payment events which are created for the account. You can filter the payment events using various search criteria.
  - **Payments** — Lists all payments created through the payment event.

This tab appears only when the refund request is in the **Draft** status.

- **Log** – Lists the complete trail of actions performed on the refund request.

## Refund Request - Main

The **Main** tab displays information about the refund request. It contains the following zones:

- [Refund Request](#) on page 1435
- [Refund Details](#) on page 1437
- [Bill Line Items](#) on page 1438

## Refund Request

The **Refund Request** zone displays the details of the refund request. This zone contains the following sections:

- **Main** — This section provides basic information about the refund request. It contains the following fields:

Field Name	Field Description
Refund Request Information	Displays information about the refund request.
Refund Request Type	Indicates the refund request type using which the refund request is created.  <b>Note:</b> It has a link. On clicking the link, the <b>Refund/Write Off Request Type</b> screen appears where you can view the details of the refund request type.
Status	Indicates the status of the refund request. The valid values are: <ul style="list-style-type: none"> <li>• Draft</li> <li>• Approval In Progress</li> <li>• Rejected</li> <li>• Processed</li> <li>• Voided</li> </ul>
Status Reason	Indicates the reason why the refund request is rejected or voided.  <b>Note:</b> This field appears only when the refund request is in the <b>Rejected</b> or <b>Voided</b> status. It has a link. On clicking the link, the <b>Status Reason</b> screen appears where you can view the details of the rejected or voided reason.

Field Name	Field Description
Account Information	Indicates the account for which the refund request is created. <b>Note:</b> It has a link. On clicking the link, the <b>Account</b> screen appears where you can view the details of the respective account.
Person Name	Indicates the person for whom the refund request is created.
Override Address	Indicates whether the account's mailing address is overridden.
Address 1	Displays the house number and apartment name.
Address 2	Displays the street name.
Address 3	Indicates the landmark, if available.
Address 4	Displays the village, town, or city name.
City	Displays the city name.
State	Displays the state name.
Country	Displays the country name.
Postal	Displays the postal or zip code.
Comments	Displays additional information about the refund request.
Total Refund Amount	Displays the total refund amount.

- **Characteristics** — Lists the characteristics defined for the refund request. It contains the following fields:

Field Name	Field Description
Effective Date	Indicates the date from when the characteristic is effective for the refund request.
Characteristic Type	Indicates the characteristic type.
Characteristic Value	Displays the value of the characteristic type.

- **Record Actions** — This section contains the following buttons:

Button Name	Button Description
Edit	Used to edit the details of the refund request. <b>Note:</b> The <b>Edit</b> button appears only when the refund request is in the <b>Draft</b> status.
Delete	Used to delete the refund request. <b>Note:</b> The <b>Delete</b> button appears only when the refund request is in the <b>Draft</b> status.
Submit	Used to submit the refund request for approval. <b>Note:</b> The <b>Submit</b> button appears only when the refund request is in the <b>Draft</b> status.

Button Name	Button Description
Approve	Used to approve the refund request.  <b>Note:</b> The <b>Approve</b> button appears only when: <ul style="list-style-type: none"> <li>The refund request is in the <b>Approval In Progress</b> status.</li> <li>A user with the approval To Do role is reviewing the refund request.</li> </ul>
Reject	Used to reject the refund request.  <b>Note:</b> The <b>Reject</b> button appears only when: <ul style="list-style-type: none"> <li>The refund request is in the <b>Approval In Progress</b> status.</li> <li>A user with the approval To Do role is reviewing the refund request.</li> </ul>
Void	Used to void the refund request.  <b>Note:</b> The <b>Void</b> button appears only when the refund request is in the <b>Processed</b> status.

- **Record Information** — This section contains the following fields:

Field Name	Field Description
Business Object	Indicates the business object using which the refund request is created. In addition, a context menu appears corresponding to this field which helps in navigating to other screens in the application.  <b>Note:</b> It has a link. On clicking the link, the <b>Business Object</b> screen appears where you can view the details of the respective business object.
Status Date/Time	Displays the date and time when the refund request status is updated
Create Date/Time	Displays the date and time when the refund request is created.

### Refund Details

The **Refund Details** zone lists the payment events, payments, and credit bill line items (such as bill segments and adjustments) that you have added to the refund request. This zone contains the following columns:

Column Name	Column Description
Entity ID	Displays the entity ID.
Entity Type	Indicates whether the entity is a payment event, payment, bill, bill segment, or an adjustment.
Currency	Indicates the currency in which the entity was created.
Entity Amount	Displays the entity amount.
Refund Amount	Displays the amount that must be refunded.  <b>Note:</b> By default, the amount which is eligible for refund appears in this column. You can edit the amount, if required. However, you cannot specify the amount greater than the eligible amount.

Column Name	Column Description
Contract Information	<p>Displays additional information about the contract against which the bill segment or adjustment is created or against which the payment is matched. In addition, this column has a context menu which helps in navigating to other screens in the application.</p> <p><b>Note:</b> It has a link. On clicking the link, the <b>Contract</b> screen appears where you can view the details of the respective contract.</p>
Adjustment Type	<p>Indicates the adjustment type using which the refund adjustment must be created.</p> <p><b>Note:</b> By default, the adjustment type specified in the refund request type appears in this column. You can change the adjustment type, if required, by editing the refund request.</p>
Adjustment Information	<p>Displays information about the refund adjustment.</p> <p><b>Note:</b></p> <p>It has a link. On clicking the link, the <b>Adjustment</b> screen appears where you can view the details of the respective adjustment.</p> <p>The data appears in this column only when the status of the refund request is <b>Processed</b>.</p> <p>The information string appears only when an algorithm of the <b>C1-ADI-INFO</b> algorithm type is attached to the <b>Adjustment Information</b> system event in the <b>Algorithms</b> tab of the <b>Installation Options — Framework</b> screen.</p>

**Note:** On clicking the Broadcast  icon corresponding to the entity type as **Bill**, the **Bill Line Items** zone appears with the details of the respective bill.

In addition to above columns, this screen contains following buttons:

Button Name	Button Description
Edit	Used to edit the details of bill line items.
Delete	Used to delete the bill line items.

### Bill Line Items

The **Bill Line Items** zone lists the debit and credit bill segments and adjustments of the bill. This zone contains the following columns:

Column Name	Column Description
Bill ID	Displays the bill ID.
Entity ID	Displays the bill segment or adjustment ID.
Entity Type	Indicates whether the entity is a bill, bill segment or an adjustment.
Currency	Displays the currency in which the entity was created.
Entity Amount	Displays the bill segment or adjustment amount.

Column Name	Column Description
Request Amount	<p>Displays the bill segment or adjustment amount which is eligible for refund. In other words, it means entity amount minus amount refunded.</p> <p><b>Note:</b> If the bill segment or adjustment has debit balance, the eligible amount for refund would be zero.</p>
Contract Information	<p>Displays additional information about the contract against which the bill segment or adjustment is created. In addition, this column has a context menu which helps in navigating to other screens in the application.</p> <p><b>Note:</b> It has a link. On clicking the link, the <b>Contract</b> screen appears where you can view the details of the respective contract.</p>
Adjustment Type	<p>Indicates the adjustment type using which the refund adjustment must be created.</p> <p><b>Note:</b> It has a link. On clicking the link, the <b>Adjustment Type</b> screen appears where you can view the details of the respective adjustment type.</p>
Adjustment Information	Displays information about the refund adjustment.

By default, the **Bill Line Items** zone does not appear in the **Main** tab. It appears only when you click the **Broadcast**  icon corresponding to the bill in the **Refund Details** zone.

#### **Related Topics**

For more information on...	See...
How to add a credit bill line item to the refund request	<a href="#">Adding a Credit Bill Line Item to the Refund Request</a> on page 1451

## **Refund Request - Bills**

The **Bills** tab allows you to search bills with credit line items, such as credit bill segments and adjustments, that you want to refund. It contains the following zones:

- [Search Bills](#) on page 1439
- [Bill Line Items](#) on page 1441

### **Search Bills**

The **Search Bills** zone lists completed bills of the account which are either with credit balance or have one or more credit line items, such as bill segments and adjustments. You can filter the bills using various search criteria. This zone contains the following two sections:

- **Search Criteria** — The **Search Criteria** section contains the following fields:

Field Name	Field Description	Mandatory (Yes or No)
Search By	Used to indicate whether you want to search for a bill using bill or bill and price item details. The valid values are: <ul style="list-style-type: none"> <li>• Bill Details</li> <li>• Bill and Price Item Details</li> </ul> <div style="border: 1px solid black; padding: 2px; margin-top: 5px;"><b>Note:</b> By default, the <b>Bill Details</b> option is selected.</div>	Yes
Bill ID	Used to search a particular bill.	No
Bill Date From	Used to search bills which are created from a particular date onwards.	No
To	Used to search bills which are created till a particular date.	No
Price Item	Used to search bills which are created for a particular price item. <div style="border: 1px solid black; padding: 2px; margin-top: 5px;"><b>Note:</b> This field appears only when you select <b>Bill and Price Item Details</b> option from the <b>Search By</b> list. You can search for a price item by clicking the <b>search</b>  icon corresponding to the field.</div>	No

- **Search Results** — On clicking the **Search** button, the search results are filtered based on the specified search criteria. The **Search Results** section contains the following columns:

Column Name	Column Description
Bill ID	Displays the bill ID.
Bill Information	Displays additional information about the bill. In addition, this column has a context menu which helps in navigating to other screens in the application. <div style="border: 1px solid black; padding: 2px; margin-top: 5px;"><b>Note:</b> It has a link. On clicking the link, the <b>Bill</b> screen appears with the details of the respective bill.</div>
Amount	Displays the total bill amount.

If you want to refund a bill with credit balance and all credit line items, you need to select the check box corresponding to the bill and then click the **Add** button in the **Search Results** section. All credit bill segments and adjustments of the bill are added in the **Refund Details** zone on the **Main** tab. However, if you select a bill (with credit balance) which contains one or more debit line items or if you select a bill (with debit balance) which contains one or more credit line items, the system will not allow you to add the credit line items by directly adding the bill. In such case, you need to individually select the credit bill segments and adjustments of the bill and then add them to the refund request.

**Note:** If a refund request is currently in progress for a credit bill segment or adjustment of a bill, those bills of the account are not listed in the **Search Bills** zone. In addition, a bill with all debit line items are not listed in the **Search Bills** zone.

### Related Topics



For more information on...	See...
How to add a credit bill line item to the refund request	<a href="#">Adding a Credit Bill Line Item to the Refund Request</a> on page 1451

### Bill Line Items

The **Bill Line Items** zone lists the debit and credit bill segments and adjustments of the bill. This zone contains the following columns:

Column Name	Column Description
Entity ID	Displays the bill segment or adjustment ID.
Entity Type	Indicates whether the entity is a bill segment or an adjustment.
Entity Information	<p>Displays additional information about the bill segment or adjustment. If the entity is a bill segment, the context menu appears in the column which helps in navigating to other screens in the application.</p> <p><b>Note:</b> It has a link. If the entity is a bill segment, the <b>Bill Segment</b> screen appears where you can view the details of the respective bill segment on clicking the link. However, if the entity is an adjustment, the <b>Adjustment</b> screen appears with the details of the respective adjustment on clicking the link.</p>
Entity Amount	Displays the bill segment or adjustment amount.
Eligible Amount	<p>Displays the bill segment or adjustment amount which is eligible for refund. In other words, it means entity amount minus amount refunded.</p> <p><b>Note:</b> If the bill segment or adjustment has debit balance, the eligible amount for refund would be zero.</p>
Amount Refunded	Displays the amount which is already refunded to the account.
Contract Information	<p>Displays additional information about the contract against which the bill segment or adjustment is created. In addition, this column has a context menu which helps in navigating to other screens in the application.</p> <p><b>Note:</b> It has a link. On clicking the link, the <b>Contract</b> screen appears where you can view the details of the respective contract.</p>

You can select one or more credit bill segments or adjustments and click the **Add** button in this zone to add selected credit bill segments or adjustments to the refund request.

By default, the **Bill Line Items** zone does not appear in the **Bills** tab. It appears only when you click the **Broadcast**  icon corresponding to the bill in the **Search Bills** zone.

### Related Topics

For more information on...	See...
How to add a credit bill line item to the refund request	<a href="#">Adding a Credit Bill Line Item to the Refund Request</a> on page 1451

## Refund Request - Payments

The **Payments** tab allows you to search payment events or individual payments that you want to refund. It contains the following zones:

- [Search Payment Event](#) on page 1442
- [Payments](#) on page 1443

### Search Payment Event

The **Search Payment Event** zone lists the payment events which are created for the account. You can filter the payment events using various search criteria. This zone contains the following two sections:

- **Search Criteria** — The **Search Criteria** section contains the following fields:

Field Name	Field Description	Mandatory (Yes or No)
Search By	Used to indicate that you want to search for a payment event using the payment details. The valid values are: <ul style="list-style-type: none"> <li>• Payment Details</li> </ul> <div style="border: 1px solid black; padding: 2px; margin-top: 5px;"> <b>Note:</b> By default, the <b>Payment Details</b> option is selected.         </div>	Yes
Payment Event ID	Used to search a particular payment event.	No
Suspense/Excess Credit Contract	Used to search payment events which include payments made against a particular suspense or excess credit contract. <div style="border: 1px solid black; padding: 2px; margin-top: 5px;"> <b>Note:</b> The suspense and excess credit contracts are listed only when these contracts are associated with the account         </div>	No
Check Number	Used to search a payment event which includes payment made through a particular check.	No
Payment Date	Used to search payment events which include payments created from a particular date onwards.	No
To	Used to search payment events which include payments created till a particular date.	No
MICR ID	Used to search payment events which include payments made with a particular MICR code.	No

- **Search Results** — On clicking the **Search** button, the search results are filtered based on the specified search criteria. The **Search Results** section contains the following columns:

Column Name	Column Description
Payment Event Information	Displays additional information about the payment event. <div style="border: 1px solid black; padding: 2px; margin-top: 5px;"> <b>Note:</b> It has a link. On clicking the link, the <b>Payment Event</b> screen appears where you can view the details of the respective payment event.         </div>
Payment Date	Displays the date when the payments were created.
Tender Amount	Displays the tender amount.
Payment Event ID	Displays the payment event ID.

If you want to refund all payments of a payment event, you need to select the check box corresponding to the payment event and then click the **Add** button in the **Search Results** section. If all payments in the payment event are matched against the same suspense or excess credit contract, the payment event is added in the **Refund Details**

zone on the **Main** tab. However, if the payments in the payment event are matched against different suspense or excess credit contracts, the payments of the payment event are added in the **Refund Details** zone.

**Note:** If a refund request is currently in progress for a payment event or for any payment of a payment event, those payments events of the account are not listed in the **Search Payment Event** zone.

### Related Topics

For more information on...	See...
How to add a payment event to the refund request	<a href="#">Adding a Payment Event to the Refund Request</a> on page 1448

### Payments

The **Payments** zone lists only those payments which are created through the payment event and are currently in the **Frozen** status. This zone contains the following columns:

Column Name	Column Description
Payment ID	Displays the payment ID. <b>Note:</b> It has a link. On clicking the link, the <b>Payment</b> screen appears where you can view the details of the respective payment.
Payee Account Information	Displays additional information about the account for which the payment was made. <b>Note:</b> It has a link. On clicking the link, the <b>Account</b> screen appears where you can view the details of the respective account.
Payment Amount	Displays the payment amount.
Payment Currency	Indicates the currency in which the payment was made.
Payment Status	Indicates the status of the payment.
Match Type	Indicates the match type using which the payment was matched.
Match Value	Indicates the entity (such as bill, contract, and so on) against which the payment was matched.
Amount Refunded	Displays the amount which is already refunded to the payor account.

You can select one or more payments and click the **Add** button in this zone to add selected payments to the refund request.

By default, the **Payments** zone does not appear in the **Payments** tab. It appears only when you click the **Broadcast**  icon corresponding to the payment event in the **Search Payment Event** zone.

### Related Topics

For more information on...	See...
How to add a payment to the refund request	<a href="#">Adding a Payment to the Refund Request</a> on page 1449

## Refund Request - Log

The **Log** tab contains the following zone:

- [Refund Request Log](#) on page 1444

## Refund Request Log

The **Refund Request Log** zone lists the complete trail of actions performed on the refund request. This zone contains the following columns:

Column Name	Column Description
Date/Time	Displays the date and time when the action was performed on the refund request.
Details	Displays the details about the action performed on the refund request.
User	Indicates the user who has performed the action on the refund request.
Log Type	Indicates the type of log.
Related Object	Indicates the object or entity which is generated when the action is performed on the refund request.
Status Reason	Displays the status reason of action performed on the refund request.

**Note:** You can manually add a log entry for the refund request by clicking the **Add Log Entry** link in the upper right corner of the **Refund Request Log** zone.

The **Add Request Log** window appears. Enter **Log Details** and click **Save**. The refund request log is added.

### Related Topics

For more information on...	See...
How to view the log of a refund request	<a href="#">Viewing the Log of a Refund Request</a> on page 1464

## Creating a Refund Request

### Prerequisites

To create a refund request, you should have:

- Refund request types defined in the application

### Procedure

To create a refund request:

1. Do either of the following:

If you want to...	Then...
Define a refund request from the <b>Account Receivable Central</b> screen	<ol style="list-style-type: none"> <li>1. Click the <b>Main</b> link in the <b>Application</b> toolbar. A list appears.</li> <li>2. From the <b>Main</b> menu, select <b>Financial</b> and then click <b>Account Receivable Central</b>.</li> <li>3. Search for the bill in the <b>Account Receivable Central</b> screen.</li> <li>4. In the <b>Search Results</b> section, select the required bill and then click <b>Refund</b>.</li> </ol>

If you want to...	Then...
	<p><b>Note:</b> Only one bill at a time is allowed to select for <b>Refund Request</b> from the <b>Account Receivable Central</b> screen.</p>
Define a refund request from the <b>Refund Request</b> screen	<ol style="list-style-type: none"> <li>1. Click the <b>Main</b> link in the <b>Application</b> toolbar. A list appears.</li> <li>2. From the <b>Main</b> menu, select <b>Financial</b> and then click <b>Refund/Write Off Request</b>. A sub-menu appears.</li> <li>3. Click the <b>Add</b> option from the <b>Refund/Write Off Request</b> sub-menu.</li> </ol>

The **Select Request Type** screen appears. It contains the following fields:

Field Name	Field Description	Mandatory (Yes or No)
Action	<p>Displays the type of request (refund or write off) to be created.</p> <p><b>Note:</b> This field is pre-populated if the refund request is created from the <b>Account Receivable Central</b> screen. This field is editable if the refund request is created from the <b>Refund/Write Off Request</b> screen.</p>	Not applicable
Refund/Write Off Request Type	<p>Used to indicate the request type using which you want to create the refund or write off request.</p> <p><b>Note:</b> The refund request types are listed when you set the <b>Action</b> field to <b>Refund</b> and the write off request types are listed when you set the <b>Action</b> field to <b>Write Off</b>.</p>	Yes

Field Name	Field Description	Mandatory (Yes or No)
Account	<p>Used to indicate the account for which you want to create the refund or write off request.</p> <p><b>Note:</b></p> <p>This field is pre-populated if the refund request is created from the <b>Account Receivable Central</b> screen.</p> <p>This field is editable if the refund request is created from the <b>Refund/Write Off Request</b> screen.</p> <p>You can search for an account by clicking the <b>Search</b>  icon corresponding to the respective field.</p>	Yes

**Tip:**

Alternatively, you can access the **Select Request Type** screen:

- By clicking the **Add** button in the **Page Title** area of **Refund/Write Off Request** screen.
- By selecting the payment which you want to refund in the **Payment Event Summary** screen and then clicking the **Refund** button. Note that the system will allow you to refund only those payments which are in the **Frozen** status and matched against the suspense or excess credit contract.

2. Select the required refund request type from the respective field.
3. Click **Save**.

The refund request is defined and the status of the refund request is set to **Draft**. The **Refund Request** screen appears where you can view the details of the refund request. It contains the following tabs:

**Note:** The refund request can be created only for bill with outstanding amount lesser than zero.

- **Main** – Displays information about the refund request. It contains the following zones:
    - **Refund Request** – Displays the details of the refund request.
    - **Refund Details** – Lists the entities, such as payment events, payments, and/or credit bill line items (such as credit bill segments and adjustments), of the account which must be refunded.
  - **Payments** — Used to search payment events or individual payments that you want to refund. This tab appears only when the refund request is in the **Draft** status.
  - **Bills** — Used to search bills with credit line items, such as credit bill segments and adjustments, that you want to refund. This tab appears only when the refund request is in the **Draft** status.
  - **Log** – Lists the complete trail of actions performed on the refund request.
4. Add payment events, payments, or credit bill line items that you want to refund.
  5. Edit the refund amount of each entity, if required.
  6. Define characteristics for the refund request, if required.
  7. Override the address if you want to sent the refund to an address other than the account's main customer address.

**Related Topics**

For more information on...	See...
<b>Refund Request</b> screen	<a href="#">Refund Request</a> on page 1434
<b>Account Receivable Central</b> screen	<a href="#">Account Receivable Central</a> on page 1236
How to add a payment event to the refund request	<a href="#">Adding a Payment Event to the Refund Request</a> on page 1448
How to add a payment to the refund request	<a href="#">Adding a Payment to the Refund Request</a> on page 1449
How to add a credit bill line item to the refund request	<a href="#">Adding a Credit Bill Line Item to the Refund Request</a> on page 1451
How to edit a refund request	<a href="#">Editing a Refund Request</a> on page 1453
How to define characteristics for a refund request	<a href="#">Defining Characteristics for a Refund Request</a> on page 1447

## Defining Characteristics for a Refund Request

### Prerequisites

To define characteristics for a refund request, you should have:

- Characteristic types defined in the application (where the characteristic entity is set to **Refund Write Off Request**)

### Procedure

To define characteristics for a refund request:

- Search for the refund request in the **Refund/Write Off Request** screen.
- In the **Search Results** section, click the link in the **Refund/Write Off Request Information** column corresponding to the refund request whose details you want to edit.

The **Refund Request** screen appears.

- Click the **Edit** button in the **Refund Request** zone.

The **Edit Refund Request** screen appears.

**Note:** The **Edit** button appears only when the refund request is in the **Draft** status.

- Ensure that the **Characteristics** section is expanded when you are editing the refund request.

The **Characteristics** section contains the following fields:

Field Name	Field Description	Mandatory (Yes or No)
Effective Date	Used to specify the date from when the characteristic is effective for the refund request.	Yes (Conditional) <b>Note:</b> This field is required when you are defining a characteristic for the refund request.
Characteristic Type	Used to indicate the characteristic type. <b>Note:</b> The list includes only those characteristic types where the characteristic entity is set to <b>Refund Write Off Request</b> .	Yes (Conditional) <b>Note:</b> This field is required when you are defining a characteristic for the refund request.

Field Name	Field Description	Mandatory (Yes or No)
Characteristic Value	Used to specify the value for the characteristic type.  <b>Note:</b> On specifying the value for a predefined characteristic type, the description of the characteristic value appears corresponding to the <b>Characteristic Value</b> field.	Yes (Conditional)  <b>Note:</b> This field is required when you are defining a characteristic for the refund request.

5. Enter the required details in the **Characteristics** section.

**Note:** If you select a predefined characteristic type, the **Search** (🔍) icon appears corresponding to the **Characteristic Value** field. On clicking the **Search** icon, you can search for a predefined characteristic value.

6. If you want to define more than one characteristic for the refund request, click the **Add** (+) icon and then repeat step 5.

**Note:** However, if you want to remove a characteristic from the refund request, click the **Delete** (🗑️) icon corresponding to the characteristic.

### Related Topics

For more information on...	See...
How to search for a refund request	<a href="#">Searching for a Refund or Write Off Request</a> on page 1427
How to create a refund request	<a href="#">Creating a Refund Request</a> on page 1428

## Adding a Payment Event to the Refund Request

### Prerequisites

To add a payment event to the refund request, you should have:

- Payments made by the account for which you need to create the refund request

### Procedure

To add a payment event to the refund request:

1. Click the **Payments** tab in the **Refund Request** screen.

The **Payments** tab appears.

2. Filter the payment events, if required, in the **Search Payment Event** zone.

**Note:** You can only refund payments, which are matched against suspense or excess credit contracts, to the payor account. Therefore, you can only view payment events which includes payments matched against suspense or excess credit contracts. If a refund request is currently in progress for a payment event or for any payment of a payment event, those payments events of the account are not listed in the **Search Payment Event** zone.

3. Select the check box corresponding to the payment event, whose payments you want to refund, in the **Search Results** section.

**Note:** You can add more than one payment event to the refund request at the same time.

4. Click **Add**.



A message appears indicating that the selected payment events are added to the refund request.

5. Click **OK**.

Note that the entity is added in the **Refund Details** zone on the **Main** tab.

**Note:**

You can only refund payments which are in the **Frozen** status.

If all payments in the payment event are matched against the same suspense or excess credit contract, the payment event is added in the **Refund Details** zone. However, if the payments in the payment event are matched against different suspense or excess credit contracts, the payments of the payment event are added in the **Refund Details** zone.

**Related Topics**

For more information on...	See...
How to create a refund request	<a href="#">Creating a Refund Request</a> on page 1428

## Adding a Payment to the Refund Request

**Prerequisites**

To add a payment to the refund request, you should have:

- Payments made by the account for which you need to create the refund request

**Procedure**

To add a payment to the refund request:

1. Click the **Payments** tab in the **Refund Request** screen.

The **Payments** tab appears.

2. Filter the payment events, if required, in the **Search Payment Event** zone.

**Note:** You can only refund payments, which are matched against suspense or excess credit contracts, to the payor account. Therefore, you can only view payment events which includes payments matched against suspense or excess credit contracts. If a refund request is currently in progress for a payment event or for any payment of a payment event, those payments events of the account are not listed in the **Search Payment Event** zone.

3. In the **Search Results** section, click the **Broadcast**  icon corresponding to the payment event whose payments you want to view.

The **Payments** zone appears.

4. Select the check box corresponding to the payment that you want to refund.

**Note:** You can add more than one payment to the refund request at the same time.

5. Click **Add**.

A message appears indicating that the selected payments are added to the refund request.

6. Click **OK**.

Note that the payments are added in the **Refund Details** zone on the **Main** tab.

**Note:** You can only refund payments which are in the **Frozen** status.

**Related Topics**

For more information on...	See...
How to create a refund request	<a href="#">Creating a Refund Request</a> on page 1428

**Adding a Credit Bill to the Refund Request**

You can refund the credit bills to the account.

**Prerequisites**

To add a credit bill to the refund request, you should have:

- Completed bills for the account with one or more credit line items

**Procedure**

To add a credit bill to the refund request:

1. Click the **Bills** tab in the **Refund Request** screen.

The **Bills** tab appears.

2. Filter the bills, if required, in the **Search Bills** zone.

**Note:** If a refund request is currently in progress for a credit bill segment or adjustment of a bill, those bills of the account are not listed in the **Search Bills** zone. In addition, a bill with all debit line items are not listed in the **Search Bills** zone.

3. Do either of the following:

If...	Then...
A bill has all credit line items and you want to add the credit bill to the refund request	<ol style="list-style-type: none"> <li>1. In the <b>Search Bills</b> zone, select the bills that you want to refund.</li> <li>2. Click the <b>Add</b> button available at the upper left corner of the <b>Search Bills</b> zone.</li> </ol> <p><b>Note:</b> Default adjustment type selected in the write off request type should be non A/P.</p>
A bill has credit balance and one or more debit line items and you want to add the credit bill to the refund request	<ol style="list-style-type: none"> <li>1. In the <b>Search Bills</b> zone, select the bills that you want to refund.</li> <li>2. Click the <b>Add</b> button available at the upper left corner of the <b>Search Bills</b> zone.</li> </ol> <p><b>Note:</b> Default adjustment type selected in the write off request type should be non A/P.</p>

4. Click **Add**.

A message appears indicating that the selected bills are added to the refund request.

**Note:** If you select a bill (with credit balance) which contains one or more debit line items or if you select a bill (with debit balance) which contains one or more credit line items, the system will not allow you to add the credit line items by directly adding the bill. In such case, you need to individually select the credit bill segments and adjustments of the bill and then add them to the refund request.

5. Click **OK**.

Note that all the credit bill segments or adjustments of the bills are added in the **Refund Details** zone on the **Main** tab.

**Note:**

Irrespective of whether you select a credit bill, or credit bill segments or adjustments, the credit bill segments or adjustments are added in the **Refund Details** zone. The credit bill is not added to the **Refund Details** zone.

The system will not allow you to add a debit line item to the **Refund Details** zone.

**Related Topics**

For more information on...	See...
How to create a refund request	<a href="#">Creating a Refund Request</a> on page 1428

## Adding a Credit Bill Line Item to the Refund Request

You can refund the credit bill line items, such as bill segments and adjustments, to the account. While adding a credit bill line item to the refund request, you can either:

- Directly add all credit line items of a bill to the refund request by adding the bill which has all bill segments and adjustments in credit
- Individually add a credit bill segment or adjustment of a bill (with one or more credit line items) to the refund request

**Prerequisites**

To add a credit bill line item to the refund request, you should have:

- Completed bills for the account with one or more credit line items

**Procedure**

To add a credit bill line item to the refund request:



1. Click the **Bills** tab in the **Refund Request** screen.

The **Bills** tab appears.

2. Filter the bills, if required, in the **Search Bills** zone.

**Note:** If a refund request is currently in progress for a credit bill segment or adjustment of a bill, those bills of the account are not listed in the **Search Bills** zone. In addition, a bill with all debit line items are not listed in the **Search Bills** zone.

3. Do either of the following:

If...	Then...
A bill has all credit line items and you want to add a particular credit bill line item to the refund request	<ol style="list-style-type: none"> <li data-bbox="846 226 1401 331">1. In the <b>Search Bills</b> zone, click the <b>Broadcast</b>  icon corresponding to the bill whose line items you want to view. The <b>Bill Line Items</b> zone appears.</li> <li data-bbox="846 411 1401 499">2. Select the check box corresponding to the credit bill segment or adjustment that you want to refund.</li> </ol>
A bill has credit balance and one or more debit line items	<ol style="list-style-type: none"> <li data-bbox="846 558 1401 663">1. In the <b>Search Bills</b> zone, click the <b>Broadcast</b>  icon corresponding to the bill whose line items you want to view. The <b>Bill Line Items</b> zone appears.</li> <li data-bbox="846 743 1401 831">2. Select the check box corresponding to the credit bill segment or adjustment that you want to refund.</li> </ol>
A bill has debit balance and one or more credit line items	<ol style="list-style-type: none"> <li data-bbox="846 890 1401 995">1. In the <b>Search Bills</b> zone, click the <b>Broadcast</b>  icon corresponding to the bill whose line items you want to view. The <b>Bill Line Items</b> zone appears.</li> <li data-bbox="846 1075 1401 1163">2. Select the check box corresponding to the credit bill segment or adjustment that you want to refund.</li> </ol>

4. Click **Add**.

A message appears indicating that the selected bill segments or adjustments are added to the refund request.

**Note:** If you select a bill (with credit balance) which contains one or more debit line items or if you select a bill (with debit balance) which contains one or more credit line items, the system will not allow you to add the credit line items by directly adding the bill. In such case, you need to individually select the credit bill segments and adjustments of the bill and then add them to the refund request.

5. Click **OK**.

Note that the credit bill segments or adjustments are added in the **Refund Details** zone on the **Main** tab.

**Note:**

Irrespective of whether you select a credit bill, or credit bill segments or adjustments, the credit bill segments or adjustments are added in the **Refund Details** zone. The credit bill is not added to the **Refund Details** zone.

The system will not allow you to add a debit line item to the **Refund Details** zone.

**Related Topics**

<b>For more information on...</b>	<b>See...</b>
How to create a refund request	<a href="#">Creating a Refund Request</a> on page 1428

## Editing a Refund Request

### Prerequisites

To edit a refund request, you should have:

- Adjustment types with A/P request type defined in the application

### Procedure

To edit a refund request:

1. Search for the refund request in the **Refund/Write Off Request** screen.
2. In the **Search Results** section, click the link in the **Refund/Write Off Request Information** column corresponding to the refund request whose details you want to edit.

The **Refund Request** screen appears.

3. Click the **Edit** button in the **Refund Request** zone.

The **Edit Refund Request** screen appears. It contains the following section:

Field Name	Field Description	Mandatory (Yes or No)
Refund Request Information	Displays information about the refund request.	Not applicable
Account Information	Indicates the account for which the refund request is created.	Not applicable
Person Name	Used to indicate the person for whom the refund request is created.	No
Override Address	Used to indicate whether the account's mailing address must be overridden.  <b>Note:</b> By default, the account's main customer's address appears in the following fields — Address 1, Address 2, Address 3, Address 4, City, Country, State, and Postal. You can override the address in these fields, if required.	No
Address 1	Used to specify the house number and apartment name.	No
Address 2	Used to specify the street name.	No
Address 3	Used to specify any landmark, if available.	No
Address 4	Used to specify the village, town, or city name.	No
City	Used to specify the city name.	No
Country	Used to specify the country name.	No

Field Name	Field Description	Mandatory (Yes or No)
State	Used to specify the state name.	No
Postal	Used to specify the postal or zip code.	No
Comments	Used to specify additional information about the refund request.	No

In addition, this screen contains the following two sections:

- **Characteristics** — Used to define characteristics for the refund request. It contains the following fields:

Field Name	Field Description	Mandatory (Yes or No)
Effective Date	Used to specify the date from when the characteristic is effective for the refund request.	Yes (Conditional) <b>Note:</b> This field is required when you are defining a characteristic for the refund request.
Characteristic Type	Used to indicate the characteristic type. <b>Note:</b> The list includes only those characteristic types where the characteristic entity is set to <b>Refund Write Off Request</b> .	Yes (Conditional) <b>Note:</b> This field is required when you are defining a characteristic for the refund request.
Characteristic Value	Used to specify the value for the characteristic type. <b>Note:</b> On specifying the value for a predefined characteristic type, the description of the characteristic value appears corresponding to the <b>Characteristic Value</b> field.	Yes (Conditional) <b>Note:</b> This field is required when you are defining a characteristic for the refund request.

4. Modify the details of the refund request, if required.
5. Define, edit, or remove characteristics from the refund request, if required.
6. Click **Save**.

The changes made to the refund request are saved.

### **Related Topics**

For more information on...	See...
How to search for a refund request	<a href="#">Searching for a Refund or Write Off Request</a> on page 1427
<b>Refund Request</b> screen	<a href="#">Refund Request</a> on page 1434
<b>Refund Request</b> zone	<a href="#">Refund Request</a> on page 1435
How to define characteristics for a refund request	<a href="#">Defining Characteristics for a Refund Request</a> on page 1447

## Editing the Refund Details

### Prerequisites

To edit the refund details, you should have:

- Adjustment types with A/P request type defined in the application

### Procedure

To edit the refund details:

1. Search for the refund request in the **Refund/Write Off Request** screen.
2. In the **Search Results** section, click the link in the **Refund/Write Off Request Information** column corresponding to the refund request whose bill line item details you want to edit.

The **Refund Request** screen appears. You can edit the bill line items by either of the following ways:

If...	Then
Select the bill whose details you want to edit in the <b>Refund Details</b> zone and click the <b>Edit</b> button available in the upper left corner of this zone.	The <b>Edit Request Details</b> screen appears.
In the <b>Refund Details</b> zone, click the <b>Broadcast</b>  icon corresponding to the bill whose line items details you want to edit.	<p>The <b>Bill Line Items</b> zone appears.</p> <div style="border: 1px solid black; padding: 5px;"> <p><b>Note:</b> This zone appears only when the Entity Type is <b>Bill</b>.</p> </div> <ol style="list-style-type: none"> <li>1. Select the bill line item whose details you want to edit in the <b>Bill Line Items</b> zone and click the <b>Edit</b> button available in the upper left corner of this zone.</li> </ol> <p>The <b>Edit Request Details</b> screen appears.</p>

**Note:** A bill line item from the refund request can be edited only when the refund request is in the **Draft** status.

The **Edit Request Details** screen contains the following fields:

Field Name	Field Description	Mandatory (Yes or No)
Request ID	Displays the refund request ID.	Not applicable
Account Information	Displays additional information about the account.	Not applicable
Adjustment Type	<p>Indicates the adjustment type of the refund request type.</p> <p>You can search for an adjustment type by clicking the <b>Search</b>  icon corresponding to the field.</p>	No

In addition to these fields, this screen contains following columns:

Column Name	Column Description
Entity Type	Indicates the entity type. The valid values are <ul style="list-style-type: none"> <li>• Adjustments</li> <li>• Bill</li> <li>• Bill Segment</li> <li>• Payment Event</li> <li>• Payment</li> </ul>
Entity ID	Displays the entity ID.
Entity Amount	Displays the entity amount.
Currency	Displays the currency in which the entity was created.
Request Amount	Displays the amount that must be refunded.
Adjustment Type	Indicates the adjustment type using which the refund adjustment must be created. <div style="border: 1px solid black; padding: 5px; margin-top: 10px;"> <p><b>Note:</b></p> <p>You can search for an account by clicking the <b>Search</b>  icon corresponding to the field.</p> </div>
Bill ID	Displays the bill ID.





In addition to the above columns, the screen has following button:

Button Name	Button Description
Override	Used to override an adjustment type of the refund request.

**Note:**

In the **Bill Line Items** zone, click the **Broadcast**  icon corresponding to the bill line item which you want to delete

Pagination is used to display limited number of records in the **Search Results** section. By default, 10 records are displayed in the **Search Results** section. You can change the number of records displayed per page, if required.

You can use the navigation buttons, such as **First** () , **Previous** () , **Next** () , and **Last** () to navigate between pages. You can also select the page to which you want to navigate from the **Go To** list.

The values appear in the **Page Limit** list only when you define values for the **PAGE\_NUMBER** lookup field.

3. Modify the details of the bill line items.
4. Click **Save**.  
The changes made to the refund bill line items are saved.

**Related Topics**

For more information on...	See...
<b>Refund Request</b> screen	<a href="#">Refund Request</a> on page 1434



For more information on...	See...
<b>Refund Request</b> zone	<a href="#">Refund Request</a> on page 1435
How to search for a refund request	<a href="#">Searching for a Refund or Write Off Request</a> on page 1427

## Deleting a Refund Request

### Procedure

To delete a refund request:

1. Search for the refund request in the **Refund/Write Off Request** screen.
2. In the **Search Results** section, click the link in the **Refund/Write Off Request Information** column corresponding to the refund request that you want to delete.

The **Refund Request** screen appears.

3. Click the **Delete** button in the **Refund Request** zone.

A message appears confirming whether you want to delete the refund request.

**Note:** The **Delete** button appears only when the refund request is in the **Draft** status.

4. Click **OK**.

The refund request is deleted.

### Related Topics

For more information on...	See...
How to search for a refund request	<a href="#">Searching for a Refund or Write Off Request</a> on page 1427
<b>Refund Request</b> screen	<a href="#">Refund Request</a> on page 1434
<b>Refund Request</b> zone	<a href="#">Refund Request</a> on page 1435

## Deleting a Bill from the Refund Request

### Procedure

To delete a bill from the refund request:

1. Search for the refund request in the **Refund/Write Off Request** screen.
2. In the **Search Results** section, click the link in the **Refund/Write Off Request Information** column corresponding to the refund request whose bill you want to delete.

The **Refund Request** screen appears.

3. In the **Refund Details** zone, select the bills and click the **Delete** button available in the upper left corner of this zone.

A message appears confirming whether you want to delete the bill from the refund request.

**Note:** You can delete bill from the refund request only when the request is in the **Draft** status.

4. Click **OK**.

The selected bill gets deleted from the refund request.

### Related Topics

For more information on...	See...
<b>Refund Request</b> screen	<a href="#">Refund Request</a> on page 1434
<b>Refund Request</b> zone	<a href="#">Refund Request</a> on page 1435
How to search for a refund request	<a href="#">Searching for a Refund or Write Off Request</a> on page 1427

## Deleting a Bill Line Item from the Refund Request

### Procedure

To delete a bill line item from the refund request:

1. Search for the refund request in the **Refund/Write Off Request** screen.
2. In the **Search Results** section, click the link in the **Refund/Write Off Request Information** column corresponding to the refund request whose bill line items you want to delete.

The **Refund Request** screen appears.

3. In the **Refund Details** zone, click the **Broadcast**  icon corresponding to the bill whose line items details you want to delete.

The **Bill Line Items** zone appears.

4. In the **Bill Line Items** zone, select the bill line items which you want to delete and click the **Delete** button available in the upper left corner of this zone.

A message appears confirming whether you want to delete the bill line items from the refund request.

#### **Note:**

You can delete a bill line item from the refund request only when the request is in the **Draft** status.

5. Click **OK**.

The selected bill line items gets deleted from the refund request.

### Related Topics

For more information on...	See...
<b>Refund Request</b> screen	<a href="#">Refund Request</a> on page 1434
<b>Refund Request</b> zone	<a href="#">Refund Request</a> on page 1435
How to search for a refund request	<a href="#">Searching for a Refund or Write Off Request</a> on page 1427

## Submitting a Refund Request

### Prerequisites

To submit a refund request, you should have:

- Payment events, payments, or credit bill line items added in the refund request

**Procedure**

To submit a refund request:

1. Search for the refund request in the **Refund/Write Off Request** screen.
2. In the **Search Results** section, click the link in the **Refund/Write Off Request Information** column corresponding to the refund request that you want to submit.

The **Refund Request** screen appears.

3. Click the **Submit** button in the **Refund Request** zone.

The system behaves in the following manner:

If...	Then...
The <b>Approval Required</b> and <b>Hierarchical Approval</b> check boxes are selected in the refund request type using which the refund request is created	A To Do of the <b>C1-REFRQ</b> To Do type is created and sent to the approver at the first level in the approval hierarchy, and the status of the refund request is changed to <b>Approval In Progress</b> .
The <b>Approval Required</b> check box is selected, but the <b>Hierarchical Approval</b> check box is not selected in the refund request type using which the refund request is created	A To Do of the <b>C1-REFRQ</b> To Do type is created and sent to the approver at the hierarchy level where the total refund amount falls within the threshold limit. In addition, the status of the refund request is changed to <b>Approval In Progress</b> .
The <b>Approval Required</b> check box is not selected in the refund request type using which the refund request is created	<p>The refund adjustments are created using the specified adjustment types and the status of the refund request is changed to <b>Processed</b>.</p> <div data-bbox="889 1020 1464 1575" style="border: 1px solid black; padding: 5px;"> <p><b>Note:</b> The refund adjustments are created in the <b>Frozen</b> status. If a match event is present for the credit bill line items (such as bill segments and adjustments) and for the payments which are matched against the excess credit contract, the existing match event is stamped on the refund adjustments and on the corresponding financial transactions. However, when a match is not present for the payments which are matched against the suspense contract or if the match events does not exist, a new match event is created and stamped on the refund adjustments and on the corresponding financial transactions. If you are doing a partial refund for any entity, the corresponding match event status is set to <b>Open</b>. However, if you are refunding the entire eligible amount, the corresponding match event status is set to <b>Balanced</b>.</p> </div>

If...	Then...
The total refund amount is less than minimum refund amount	<p>The write up adjustment is created using the write up adjustment type specified in the refund request type. In addition, the status of the refund request is changed to <b>Processed</b>.</p> <p><b>Note:</b> The write up adjustment is created in the <b>Frozen</b> status. If a match event is present for the credit bill line items (such as bill segments and adjustments) and for the payments which are matched against the excess credit contract, the existing match event is stamped on the write up adjustment and on the corresponding financial transaction. However, when a match event is not present for the payments which are matched against the suspense contract or if the match events does not exist, a new match event is created and stamped on the write up adjustment and on the corresponding financial transaction. If you are doing a partial refund for any entity, the corresponding match event status is set to <b>Open</b>. However, if you are refunding the entire eligible amount, the corresponding match event status is set to <b>Balanced</b>.</p>
The total refund amount is less than the minimum threshold amount	<p>The refund request is automatically approved by the system and refund adjustments are created using the specified adjustment types. In addition, the status of the refund request is changed to <b>Processed</b>.</p> <p><b>Note:</b> The refund adjustments are created in the <b>Frozen</b> status. If a match event is present for the credit bill line items (such as bill segments and adjustments) and for the payments which are matched against the excess credit contract, the existing match event is stamped on the refund adjustments and on the corresponding financial transactions. However, when a match event is not present for the payments which are matched against the suspense contract or if the match events does not exist, a new match event is created and stamped on the refund adjustments and on the corresponding financial transactions. If you are doing a partial refund for any entity, the corresponding match event status is set to <b>Open</b>. However, if you are refunding the entire eligible amount, the corresponding match event status is set to <b>Balanced</b>.</p>

**Note:** The **Submit** button appears only when the refund request is in the **Draft** status.

### **Related Topics**

For more information on...	See...
How to search for a refund request	<a href="#">Searching for a Refund or Write Off Request</a> on page 1427
<b>Refund Request</b> screen	<a href="#">Refund Request</a> on page 1434

<b>For more information on...</b>	<b>See...</b>
<b>Refund Request</b> zone	<a href="#">Refund Request</a> on page 1435

## Approving a Refund Request

You can view the number of refund requests which are pending for approval in the **Refund/Write Off Request** screen. The approver can review, and accordingly approve or reject the refund request based on the observations.

**Note:** The system will not allow you to approve or reject a refund request submitted by you.

### Procedure

To approve a refund request:

1. Do either of the following:

<b>If you want to...</b>	<b>Then...</b>
Approve a refund request through the <b>Refund/Write Off Request</b> screen	<ol style="list-style-type: none"> <li>1. Search for the refund request in the <b>Refund/Write Off Request</b> screen.</li> <li>2. In the <b>Search Results</b> section, click the link in the <b>Refund/Write Off Request Information</b> column corresponding to the refund request which you want to review.</li> </ol>
Approve a refund request from the <b>To Do List</b> screen	<ol style="list-style-type: none"> <li>1. Click the <b>Menu</b> link in the <b>Application</b> toolbar. A list appears.</li> <li>2. From the <b>Main</b> menu, select <b>To Do</b> and then click <b>To Do List</b>. The <b>To Do Type for User Search</b> window appears.</li> <li>3. Enter <b>C1-REFRQ</b> in the <b>To Do Type</b> field.</li> <li>4. Click the <b>Search</b> button corresponding to the <b>To Do Type</b> field. The <b>To Do List</b> screen appears.</li> <li>5. Select the <b>Open</b> option from the <b>Filter by</b> list to view all unassigned To Dos.</li> <li>6. Click the link in the <b>Message</b> column corresponding to the To Do of the refund request that you want to review.</li> </ol>

The **Refund Request** screen appears.

2. Review the refund request details.
3. Click the **Approve** button in the **Refund Request** zone.

The system behaves in the following manner:

If...	Then
<p>The <b>Hierarchical Approval</b> check box is selected in the refund request type using which the refund request is created and the total refund amount is greater than the threshold amount specified at the next level in the approval hierarchy</p>	<p>A To Do of the <b>C1-REFRQ</b> To Do type is created and sent to the approver at the next level in the approval hierarchy, and the status of the refund request remains as <b>Approval In Progress</b>.</p>
<p>The <b>Hierarchical Approval</b> check box is selected in the refund request type using which the refund request is created and the total refund amount is less than the threshold amount specified at the next level in the approval hierarchy</p>	<p>The refund adjustments are created using the specified adjustment types and the status of the refund request is changed to <b>Processed</b>.</p> <div data-bbox="889 499 1468 1058" style="border: 1px solid black; padding: 5px;"> <p><b>Note:</b> The refund adjustments are created in the <b>Frozen</b> status. If a match event is present for the credit bill line items (such as bill segments and adjustments) and for the payments which are matched against the excess credit contract, the existing match event is stamped on the refund adjustments and on the corresponding financial transactions. However, when a match event is not present for the payments which are matched against the suspense contract or if the match events does not exist, a new match event is created and stamped on the refund adjustments and on the corresponding financial transactions. If you are doing a partial refund for any entity, the corresponding match event status is set to <b>Open</b>. However, if you are refunding the entire eligible amount, the corresponding match event status is set to <b>Balanced</b>.</p> </div>
<p>The <b>Hierarchical Approval</b> check box is not selected in the refund request type using which the refund request is created</p>	<p>The refund adjustments are created using the specified adjustment types and the status of the refund request is changed to <b>Processed</b>.</p> <div data-bbox="889 1199 1468 1757" style="border: 1px solid black; padding: 5px;"> <p><b>Note:</b> The refund adjustments are created in the <b>Frozen</b> status. If a match event is present for the credit bill line items (such as bill segments and adjustments) and for the payments which are matched against the excess credit contract, the existing match event is stamped on the refund adjustments and on the corresponding financial transactions. However, when a match event is not present for the payments which are matched against the suspense contract or if the match events does not exist, a new match event is created and stamped on the refund adjustments and on the corresponding financial transactions. If you are doing a partial refund for any entity, the corresponding match event status is set to <b>Open</b>. However, if you are refunding the entire eligible amount, the corresponding match event status is set to <b>Balanced</b>.</p> </div>

**Note:** The **Approve** button appears only when:

- The refund request is in the **Approval In Progress** status.
- A user with the approval To Do role is reviewing the refund request.

### **Related Topics**

<b>For more information on...</b>	<b>See...</b>
How to search for a refund request	<a href="#">Searching for a Refund or Write Off Request</a> on page 1427
<b>Refund Request</b> screen	<a href="#">Refund Request</a> on page 1434
<b>Refund Request</b> zone	<a href="#">Refund Request</a> on page 1435

## **Rejecting a Refund Request**

### **Prerequisites**

To reject a refund request, you should have:

- Rejection reasons defined in the application

### **Note:**

While rejecting a refund request, you need to specify the reason why you want to reject the refund request. You can select the appropriate rejection reason only when you have defined the reasons for the **Rejected** status of the **C1-RefundReq** business object in the **Status Reason** screen.

The system will not allow you to approve or reject a refund request submitted by you.

### **Procedure**

To reject a refund request:

1. Do either of the following:

<b>If you want to...</b>	<b>Then...</b>
Reject a refund request through the <b>Refund/Write Off Request</b> screen	<ol style="list-style-type: none"> <li>1. Search for the refund request in the <b>Refund/Write Off Request</b> screen.</li> <li>2. In the <b>Search Results</b> section, click the link in the <b>Refund/Write Off Request Information</b> column corresponding to the refund request which you want to review.</li> </ol>
Reject a refund request from the <b>To Do List</b> screen	<ol style="list-style-type: none"> <li>1. Click the <b>Menu</b> link in the <b>Application</b> toolbar. A list appears.</li> <li>2. From the <b>Main</b> menu, select <b>To Do</b> and then click <b>To Do List</b>.  The <b>To Do Type for User Search</b> window appears.</li> </ol>

If you want to...	Then...
	<ol style="list-style-type: none"> <li>3. Enter <b>C1-REFRQ</b> in the <b>To Do Type</b> field.</li> <li>4. Click the <b>Search</b> button corresponding to the <b>To Do Type</b> field. The <b>To Do List</b> screen appears.</li> <li>5. Select the <b>Open</b> option from the <b>Filter by</b> list to view all unassigned To Dos.</li> <li>6. Click the link in the <b>Message</b> column corresponding to the To Do of the refund request that you want to review.</li> </ol>

The **Refund Request** screen appears.

2. Review the refund request details.
3. Click the **Reject** button in the **Refund Request** zone.

The **Reject Refund Request** window appears. It contains following fields:

Field Name	Field Description	Mandatory (Yes or No)
Status Reason	Used to indicate the reason why you want to reject the refund request.	Yes
Comments	Used to specify additional information while rejecting the refund request.	No

**Note:** The **Reject** button appears only when:

- The refund request is in the **Approval In Progress** status.
- A user with the approval To Do role is reviewing the refund request.

4. Select the rejection reason from the **Status Reason** list.
5. Click **Save**.

The status of the refund request is changed to **Rejected**.

### Related Topics

For more information on...	See...
How to search for a refund request	<a href="#">Searching for a Refund or Write Off Request</a> on page 1427
<b>Refund Request</b> screen	<a href="#">Refund Request</a> on page 1434
<b>Refund Request</b> zone	<a href="#">Refund Request</a> on page 1435

## Viewing the Log of a Refund Request

### Procedure

To view the log of a refund request:



1. Search for the refund request in the **Refund/Write Off Request** screen.
2. In the **Search Results** section, click the link in the **Refund/Write Off Request Information** column corresponding to the refund request whose log you want to view.

The **Refund Request** screen appears. It consists of the following tabs:

- **Main** – Displays information about the refund request. It contains the following zones:
  - **Refund Request** – Displays the details of the refund request.
  - **Refund Details** – Lists the entities, such as payment events, payments, and/or credit bill line items (such as credit bill segments and adjustments), of the account which must be refunded.
  - **Bill Line Items** — Displays the details of the bill which must be refunded.

**Note:**

This zone appears when you click the Broadcast  icon corresponding to the entity type as **Bill** in the **Refund Details** zone.

- **Payments** — Used to search payment events or individual payments that you want to refund. This tab appears only when the refund request is in the **Draft** status.
  - **Bills** — Used to search bills with credit line items, such as credit bill segments and adjustments, that you want to refund. This tab appears only when the refund request is in the **Draft** status.
  - **Log** – Lists the complete trail of actions performed on the refund request.
3. Click the **Log** tab.
  4. View the log of the refund request in the **Refund Request Log** zone.

**Note:** You can manually add a log entry for the refund request by clicking the **Add Log Entry** link in the upper right corner of the **Refund Request Log** zone.

### **Related Topics**

<b>For more information on...</b>	<b>See...</b>
How to search for a refund request	<a href="#">Searching for a Refund or Write Off Request</a> on page 1427
How to add a log entry for a refund request	<a href="#">Adding a Log Entry for a Refund Request</a> on page 1465
<b>Refund Request Log</b> zone	<a href="#">Refund Request Log</a> on page 1444

## **Adding a Log Entry for a Refund Request**

### **Procedure**

To add a log entry for a refund request:

1. Search for the refund request in the **Refund/Write Off Request** screen.
2. In the **Search Results** section, click the link in the **Refund/Write Off Request Information** column corresponding to the refund request whose log you want to edit.

The **Refund Request** screen appears. It consists of the following tabs:

- **Main** – Displays information about the refund request. It contains the following zones:
  - **Refund Request** – Displays the details of the refund request.

- **Refund Details** – Lists the entities, such as payment events, payments, and/or credit bill line items (such as credit bill segments and adjustments), of the account which must be refunded.
  - **Payments** — Used to search payment events or individual payments that you want to refund. This tab appears only when the refund request is in the **Draft** status.
  - **Bills** — Used to search bills with credit line items, such as credit bill segments and adjustments, that you want to refund. This tab appears only when the refund request is in the **Draft** status.
  - **Log** – Lists the complete trail of actions performed on the refund request.
3. Click the **Log** tab.  
The **Log** tab appears.
  4. Click the **Add Log Entry** link in the upper right corner of the **Refund Request Log** zone.  
The **Add Request Log** window appears. It contains the following fields:

Field Name	Field Description	Mandatory (Yes or No)
Request Information	Displays information about the refund request.	Not applicable
Log Details	Used to specify additional comments on the refund request.	Yes

5. Enter the comments in the **Log Details** field.
6. Click **Save**.  
The log entry is added in the **Refund Request Log** zone.

#### **Related Topics**

For more information on...	See...
How to search for a refund request	<a href="#">Searching for a Refund or Write Off Request</a> on page 1427

## **Voiding a Refund Request**

There might be situations when incorrect refund request is processed in the system. In such case, the system provides you with an ability to void or cancel the refund request. However, note that you can void a refund request only when the refund request is in the **Processed** status.

#### **Prerequisites**

To void a refund request, you should have:

- Void reasons defined in the application

**Note:** While voiding a refund request, you need to specify the reason why you want to void the refund request. You can select the appropriate void reason only when you have defined the reasons for the **Voided** status of the **C1-RefundReq** business object in the **Status Reason** screen.

#### **Procedure**

To void a refund request:

1. Search for the refund request in the **Refund/Write Off Request** screen.
2. In the **Search Results** section, click the link in the **Refund/Write Off Request Information** column corresponding to the refund request that you want to void.

The **Refund Request** screen appears.

- Click the **Void** button in the **Refund Request** zone.

The **Void Reason** window appears. It contains the following fields:

Field Name	Field Description	Mandatory (Yes or No)
Status Reason	Used to indicate the reason why you want to void the refund request.	Yes
Comments	Used to specify additional information while voiding the refund request.	No

**Note:** The **Void** button appears only when the refund request is in the **Processed** status.

- Select the void reason from the **Status Reason** list.
- Click **Save**.

The status of the refund request is changed to **Voided**.

**Note:** The **C1-REFVOID** algorithm cancels all the frozen adjustments created for the refund request which is in the **Processed** state.

### Related Topics

For more information on...	See...
How to search for a refund request	<a href="#">Searching for a Refund or Write Off Request</a> on page 1427
<b>Refund Request</b> screen	<a href="#">Refund Request</a> on page 1434
<b>Refund Request</b> zone	<a href="#">Refund Request</a> on page 1435

## Write Off Request

Once you create a write off request, the **Write Off Request** screen allows you to:

- Edit and delete a write off request
- View the details of a write off request
- Submit a write off request for approval
- Approve or reject a write off request
- View the log of a write off request
- Add a log entry for a write off request
- Cancel a write off request

This screen consists of the following tabs:

- Main** – Displays information about the write off request. It contains the following zones:
  - Write Off Request** – Displays the details of the write off request.
  - Write Off Details** – Lists the debit bill line items (such as debit bill segments and adjustments) of the account which must be written off.
  - Bill Line Items** — Displays the details of the bill which must be written off.

**Note:**

This zone appears when you click the Broadcast  icon corresponding to the entity type as **Bill** in the **Write Off Details** zone.

- **Bills** — Used to search bills with debit line items, such as debit bill segments and adjustments, that you want to write off. It contains the following zones:
  - **Search Bills** — Lists completed bills of the account which are either with debit balance or have one or more debit line items, such as bill segments and adjustments. You can filter the bills using various search criteria.
  - **Bill Line Items** — Lists the debit and credit bill segments and adjustments of the bill.

This tab appears only when the write off request is in the **Draft** status.

- **Log** – Lists the complete trail of actions performed on the write off request.

## Write Off Request - Main

The **Main** tab displays information about the write off request. It contains the following zones:

- [Write Off Request](#) on page 1468
- [Write Off Details](#) on page 1470
- [Bill Line Items](#) on page 1471

## Write Off Request

The **Write Off Request** zone displays the details of the write off request. This zone contains the following sections:

- **Main** — This section provides basic information about the write off request. It contains the following fields:

Field Name	Field Description
Write Off Request Information	Displays information about the write off request.
Write Off Request Type	Indicates the write off request type using which the write off request is created.  <b>Note:</b> It has a link. On clicking the link, the <b>Refund/Write Off Request Type</b> screen appears where you can view the details of the write off request type.
Status	Indicates the status of the write off request. The valid values are: <ul style="list-style-type: none"> <li>• Draft</li> <li>• Approval In Progress</li> <li>• Rejected</li> <li>• Processed</li> <li>• Cancelled</li> </ul>

Field Name	Field Description
Status Reason	<p>Indicates the reason why the write off request is rejected or cancelled.</p> <p><b>Note:</b> This field appears only when the write off request is in the <b>Rejected</b> or <b>Cancelled</b> status. It has a link. On clicking the link, the <b>Status Reason</b> screen appears where you can view the details of the rejected or cancelled reason.</p>
Account Information	<p>Indicates the account for which the write off request is created.</p> <p><b>Note:</b> It has a link. On clicking the link, the <b>Account</b> screen appears where you can view the details of the respective account.</p>
Comments	Displays additional information about the write off request.
Total Write Off Amount	Displays the total write off amount.

- **Characteristics** — Lists the characteristics defined for the write off request. It contains the following fields:

Field Name	Field Description
Effective Date	Indicates the date from when the characteristic is effective for the write off request.
Characteristic Type	Indicates the characteristic type.
Characteristic Value	Displays the value of the characteristic type.

- **Record Actions** — This section contains the following buttons:

Button Name	Button Description
Edit	<p>Used to edit the details of the write off request.</p> <p><b>Note:</b> The <b>Edit</b> button appears only when the write off request is in the <b>Draft</b> status.</p>
Delete	<p>Used to delete the write off request.</p> <p><b>Note:</b> The <b>Delete</b> button appears only when the write off request is in the <b>Draft</b> status.</p>
Submit	<p>Used to submit the write off request for approval.</p> <p><b>Note:</b> The <b>Submit</b> button appears only when the write off request is in the <b>Draft</b> status.</p>
Approve	<p>Used to approve the write off request.</p> <p><b>Note:</b> The <b>Approve</b> button appears only when:</p> <ul style="list-style-type: none"> <li>• The write off request is in the <b>Approval In Progress</b> status.</li> <li>• A user with the approval To Do role is reviewing the write off request.</li> </ul>

Button Name	Button Description
Reject	Used to reject the write off request.  <b>Note:</b> The <b>Reject</b> button appears only when: <ul style="list-style-type: none"> <li>The write off request is in the <b>Approval In Progress</b> status.</li> <li>A user with the approval To Do role is reviewing the write off request.</li> </ul>
Cancel	Used to cancel the write off request.  <b>Note:</b> The <b>Cancel</b> button appears only when the write off request is in the <b>Processed</b> status.

- **Record Information** — This section contains the following fields:

Field Name	Field Description
Business Object	Indicates the business object using which the write off request is created. In addition, a context menu appears corresponding to this field which helps in navigating to other screens in the application.  <b>Note:</b> It has a link. On clicking the link, the <b>Business Object</b> screen appears where you can view the details of the respective business object.
Status Date/Time	Displays the date and time when the write off request status is updated
Create Date/Time	Displays the date and time when the write off request is created.

### Write Off Details

The **Write Off Details** zone lists the debit bill line items (such as bill segments and adjustments) that you have added to the write off request. This zone contains the following columns:

Column Name	Column Description
Entity ID	Displays the entity ID.
Entity Type	Indicates whether the entity is a bill, bill segment or an adjustment.
Currency	Indicates the currency in which the entity was created.
Entity Amount	Displays the entity amount.
Write Off Amount	Displays the amount that must be written off.  <b>Note:</b> By default, the amount which is eligible for write off appears in this column. You can edit the amount, if required. However, you cannot specify the amount greater than the eligible amount.
Contract Information	Displays additional information about the contract against which the bill segment or adjustment is created. In addition, this column has a context menu which helps in navigating to other screens in the application.  <b>Note:</b> It has a link. On clicking the link, the <b>Contract</b> screen appears where you can view the details of the respective contract.

Column Name	Column Description
Adjustment Type	<p>Indicates the adjustment type using which the write off adjustment must be created.</p> <p><b>Note:</b> By default, the adjustment type specified in the write off request type appears in this column. You can change the adjustment type, if required, by editing the write off request.</p>
Adjustment Information	<p>Displays information about the write off adjustment.</p> <p><b>Note:</b></p> <p>It has a link. On clicking the link, the <b>Adjustment</b> screen appears where you can view the details of the respective adjustment.</p> <p>The data appears in this column only when the status of the write off request is <b>Processed</b>.</p> <p>The information string appears only when an algorithm of the <b>C1-ADI-INFO</b> algorithm type is attached to the <b>Adjustment Information</b> system event in the <b>Algorithms</b> tab of the <b>Installation Options — Framework</b> screen.</p>

**Note:**

On clicking the **Broadcast**  icon corresponding to the entity type as **Bill**, the **Bill Line Items** zone appears with the details of the respective bill.

In addition to above columns, this screen contains following buttons:

Button Name	Button Description
Edit	Used to edit the details of bill line items.
Delete	Used to delete the bill line items.

**Bill Line Items**

The **Bill Line Items** zone lists the debit and credit bill segments and adjustments of the bill. This zone contains the following columns:

Column Name	Column Description
Bill ID	Displays the bill ID.
Entity ID	Displays the bill segment or adjustment ID.
Entity Type	Indicates whether the entity is a bill, bill segment or an adjustment.
Currency	Displays the currency in which the entity was created.
Entity Amount	Displays the bill segment or adjustment amount.
Request Amount	<p>Displays the bill segment or adjustment amount which is eligible for refund. In other words, it means entity amount minus amount refunded.</p> <p><b>Note:</b> If the bill segment or adjustment has debit balance, the eligible amount for refund would be zero.</p>

Column Name	Column Description
Contract Information	<p>Displays additional information about the contract against which the bill segment or adjustment is created. In addition, this column has a context menu which helps in navigating to other screens in the application.</p> <p><b>Note:</b> It has a link. On clicking the link, the <b>Contract</b> screen appears where you can view the details of the respective contract.</p>
Adjustment Type	<p>Indicates the adjustment type using which the refund adjustment must be created.</p> <p><b>Note:</b> It has a link. On clicking the link, the <b>Adjustment Type</b> screen appears where you can view the details of the respective adjustment type.</p>
Adjustment Information	Displays information about the refund adjustment.

By default, the **Bill Line Items** zone does not appear in the **Main** tab. It appears only when you click the **Broadcast**  icon corresponding to the bill in the **Write Off Details** zone.

### Related Topics

For more information on...	See...
How to add a debit bill line item to the write off request	<a href="#">Adding a Debit Bill Line Item to the Write Off Request</a> on page 1480

## Write Off Request - Bills

The **Bills** tab allows you to search bills with debit line items, such as debit bill segments and adjustments, that you want to write off. It contains the following zones:

- [Search Bill](#)
- [Bill Line Items](#) on page 1473

### Search Bills

The **Search Bills** zone lists completed bills of the account which are either with debit balance or have one or more debit line items, such as bill segments and adjustments. You can filter the bills using various search criteria. This zone contains the following two sections:

- **Search Criteria** — The **Search Criteria** section contains the following fields:

Field Name	Field Description	Mandatory (Yes or No)
Search By	<p>Used to indicate that you want to search for a bill using the bill details. The valid values are:</p> <ul style="list-style-type: none"> <li>• Bill Details</li> <li>• Bill and Price Item Details</li> </ul> <p><b>Note:</b> By default, the <b>Bill Details</b> option is selected.</p>	Yes
Bill ID	Used to search a particular bill.	No
Bill Date From	Used to search bills which are created from a particular date onwards.	No



Field Name	Field Description	Mandatory (Yes or No)
To	Used to search bills which are created till a particular date.	No
Price Item	Used to search bills which are created for a particular price item.  <div style="border: 1px solid black; padding: 5px;"> <p><b>Note:</b> This field appears only when you select <b>Bill and Price Item Details</b> option from the <b>Search By</b> list. You can search for a price item by clicking the <b>search</b>  icon corresponding to the field.</p> </div>	No

- **Search Results** — On clicking the **Search** button, the search results are filtered based on the specified search criteria. The **Search Results** section contains the following columns:

Column Name	Column Description
Bill ID	Displays the bill ID.
Bill Information	Displays additional information about the bill. In addition, this column has a context menu which helps in navigating to other screens in the application.  <div style="border: 1px solid black; padding: 5px;"> <p><b>Note:</b> It has a link. On clicking the link, the <b>Bill</b> screen appears with the details of the respective bill.</p> </div>
Amount	Displays the total bill amount.

If you want to write off a bill with debit balance and all debit line items, you need to select the check box corresponding to the bill and then click the **Add** button in the **Search Results** section. All debit bill segments and adjustments of the bill are added in the **Write Off Details** zone on the **Main** tab. However, if you select a bill (with debit balance) which contains one or more credit line items or if you select a bill (with credit balance) which contains one or more debit line items, the system will not allow you to add the debit line items by directly adding the bill. In such case, you need to individually select the debit bill segments and adjustments of the bill and then add them to the write off request.

**Note:** If a write off request is currently in progress for a debit bill segment or adjustment of a bill, those bills of the account are not listed in the **Search Bills** zone. In addition, a bill with all credit line items are not listed in the **Search Bills** zone.

### Related Topics

For more information on...	See...
How to add a debit bill line item to the write off request	<a href="#">Adding a Debit Bill Line Item to the Write Off Request</a> on page 1480

### **Bill Line Items**

The **Bill Line Items** zone lists the debit and credit bill segments and adjustments of the bill. This zone contains the following columns:

Column Name	Column Description
Entity ID	Displays the bill segment or adjustment ID.

Column Name	Column Description
Entity Type	Indicates whether the entity is a bill segment or an adjustment.
Entity Information	Displays additional information about the bill segment or adjustment. If the entity is a bill segment, the context menu appears in the column which helps in navigating to other screens in the application.  <b>Note:</b> It has a link. If the entity is a bill segment, the <b>Bill Segment</b> screen appears where you can view the details of the respective bill segment on clicking the link. However, if the entity is an adjustment, the <b>Adjustment</b> screen appears with the details of the respective adjustment on clicking the link.
Entity Amount	Displays the bill segment or adjustment amount.
Eligible Amount	Displays the bill segment or adjustment amount which is eligible for write off. In other words, it means entity amount minus amount written off.  <b>Note:</b> If the bill segment or adjustment has credit balance, the eligible amount for write off would be zero.
Amount Written Off	Displays the amount which is already written off to the account.
Contract Information	Displays additional information about the contract against which the bill segment or adjustment is created. In addition, this column has a context menu which helps in navigating to other screens in the application.  <b>Note:</b> It has a link. On clicking the link, the <b>Contract</b> screen appears where you can view the details of the respective contract.

You can select one or more debit bill segments or adjustments and click the **Add** button in this zone to add selected debit bill segments or adjustments to the write off request.

By default, the **Bill Line Items** zone does not appear in the **Bills** tab. It appears only when you click the **Broadcast**  icon corresponding to the bill in the **Search Bills** zone.

### **Related Topics**

For more information on...	See...
How to add a debit bill line item to the write off request	<a href="#">Adding a Debit Bill Line Item to the Write Off Request</a> on page 1480

## **Write Off Request - Log**

The **Log** tab contains the following zone:

- [Write Off Request Log](#) on page 1474

### **Write Off Request Log**

The **Write Off Request Log** zone lists the complete trail of actions performed on the write off request. This zone contains the following columns:

Column Name	Column Description
Date/Time	Displays the date and time when the action was performed on the write off request.
Details	Displays the details about the action performed on the write off request.

Column Name	Column Description
User	Indicates the user who has performed the action on the write off request.
Log Type	Indicates the type of log.
Related Object	Indicates the object or entity which is generated when the action is performed on the write off request.
Status Reason	Displays the status reason of action performed on the write off request.

**Note:** You can manually add a log entry for the write off request by clicking the **Add Log Entry** link in the upper right corner of the **Write Off Request Log** zone.

The **Add Request Log** window appears. Enter **Log Details** and click **Save**. The write off request log is added.

### Related Topics

For more information on...	See...
How to view the log of a write off request	<a href="#">Viewing the Log of a Write Off Request</a> on page 1491

## Creating a Write Off Request

### Prerequisites

To create a write off request, you should have:

- Write off request types defined in the application

### Procedure

To create a write off request:

1. Do either of the following:

If you want to...	Then...
Define a write off request from the <b>Account Receivable Central</b> screen	<ol style="list-style-type: none"> <li>1. Click the <b>Main</b> link in the <b>Application</b> toolbar. A list appears.</li> <li>2. From the <b>Main</b> menu, select <b>Financial</b> and then click <b>Account Receivable Central</b>.</li> <li>3. Search for the bill in the <b>Account Receivable Central</b> screen.</li> <li>4. In the <b>Search Results</b> section, select the required bill and then click <b>Write Off</b>.</li> </ol> <p><b>Note:</b> Only one bill at a time is allowed to select for <b>Write Off Request</b> from the <b>Account Receivable Central</b> screen.</p>
Define a write off request from the <b>Write Off Request</b> screen	<ol style="list-style-type: none"> <li>1. Click the <b>Main</b> link in the <b>Application</b> toolbar. A list appears.</li> <li>2. From the <b>Main</b> menu, select <b>Financial</b> and then click <b>Refund/Write Off Request</b>.</li> </ol>

If you want to...	Then...
	<p>A sub-menu appears.</p> <p>3. Click the <b>Add</b> option from the <b>Refund/Write Off Request</b> sub-menu.</p>

The **Select Request Type** screen appears. It contains the following fields:

Field Name	Field Description	Mandatory (Yes or No)
Action	<p>Displays the type of request (refund or write off) to be created.</p> <div data-bbox="651 585 1122 877" style="border: 1px solid black; padding: 5px;"> <p><b>Note:</b></p> <p>This field is pre-populated if the write off request is created from the <b>Account Receivable Central</b> screen.</p> <p>This field is editable if the write off request is created from the <b>Refund/Write Off Request</b> screen.</p> </div>	Yes
Refund/Write Off Request Type	<p>Used to indicate the request type using which you want to create the refund or write off request.</p> <div data-bbox="651 1016 1122 1163" style="border: 1px solid black; padding: 5px;"> <p><b>Note:</b> The refund request types are listed when you set the <b>Action</b> field to <b>Refund</b> and the write off request types are listed when you set the <b>Action</b> field to <b>Write Off</b>.</p> </div>	Yes
Account	<p>Used to indicate the account for which you want to create the refund or write off request.</p> <div data-bbox="651 1268 1122 1667" style="border: 1px solid black; padding: 5px;"> <p><b>Note:</b></p> <p>This field is pre-populated if the write off request is created from the <b>Account Receivable Central</b> screen.</p> <p>This field is editable if the write off request is created from the <b>Refund/Write Off Request</b> screen.</p> <p>You can search for an account by clicking the <b>Search</b>  icon corresponding to the respective field.</p> </div>	Yes

**Tip:** Alternatively, you can access the **Select Request Type** screen by clicking the **Add** button in the **Page Title** area of the **Refund/Write Off Request** screen.

2. Select the required write off request type and account from the respective fields.
3. Click **Save**.

The write off request is defined and the status of the write off request is set to **Draft**. The **Write Off Request** screen appears with the details of the write off request. It contains the following tabs:

**Note:** The write off request can be created only for bill with outstanding amount greater than zero.

- **Main** – Displays information about the write off request. It contains the following zones:
    - **Write Off Request** – Displays the details of the write off request.
    - **Write Off Details** – Lists the debit bill line items (such as debit bill segments and adjustments) of the account which must be written off.
  - **Bills** — Used to search bills with debit line items, such as debit bill segments and adjustments, that you want to write off. This tab appears only when the write off request is in the **Draft** status.
  - **Log** – Lists the complete trail of actions performed on the write off request.
4. Add debit bill line items that you want to write off.
  5. Edit the write off amount of each entity, if required.
  6. Define characteristics for the write off request, if required.

### Related Topics

For more information on...	See...
<b>Write Off Request</b> screen	<a href="#">Write Off Request</a> on page 1467
<b>Account Receivable Central</b> screen	<a href="#">Account Receivable Central</a> on page 1236
How to add a debit bill line item to the write off request	<a href="#">Adding a Debit Bill Line Item to the Write Off Request</a> on page 1480
How to edit a write off request	<a href="#">Editing a Write Off Request</a> on page 1481
How to define characteristics for a write off request	<a href="#">Defining Characteristics for a Write Off Request</a> on page 1477

## Defining Characteristics for a Write Off Request

### Prerequisites

To define characteristics for a write off request, you should have:

- Characteristic types defined in the application (where the characteristic entity is set to **Refund Write Off Request**)

### Procedure

To define characteristics for a write off request:

1. Search for the write off request in the **Refund/Write Off Request** screen.
2. In the **Search Results** section, click the link in the **Refund/Write Off Request Information** column corresponding to the write off request whose details you want to edit.

The **Write Off Request** screen appears.

3. Click the **Edit** button in the **Write Off Request** zone.

The **Edit Write Off Request** screen appears.

**Note:** The **Edit** button appears only when the write off request is in the **Draft** status.

4. Ensure that the **Characteristics** section is expanded when you are editing the write off request.

The **Characteristics** section contains the following fields:

Field Name	Field Description	Mandatory (Yes or No)
Effective Date	Used to specify the date from when the characteristic is effective for the write off request.	Yes (Conditional) <b>Note:</b> This field is required when you are defining a characteristic for the write off request.
Characteristic Type	Used to indicate the characteristic type. <b>Note:</b> The list includes only those characteristic types where the characteristic entity is set to <b>Refund Write Off Request</b> .	Yes (Conditional) <b>Note:</b> This field is required when you are defining a characteristic for the write off request.
Characteristic Value	Used to specify the value for the characteristic type. <b>Note:</b> On specifying the value for a predefined characteristic type, the description of the characteristic value appears corresponding to the <b>Characteristic Value</b> field.	Yes (Conditional) <b>Note:</b> This field is required when you are defining a characteristic for the write off request.

5. Enter the required details in the **Characteristics** section.

**Note:** If you select a predefined characteristic type, the **Search**  icon appears corresponding to the **Characteristic Value** field. On clicking the **Search** icon, you can search for a predefined characteristic value.

6. If you want to define more than one characteristic for the write off request, click the **Add**  icon and then repeat step 5.

**Note:** However, if you want to remove a characteristic from the write off request, click the **Delete**  icon corresponding to the characteristic.

### Related Topics

For more information on...	See...
How to search for a write off request	<a href="#">Searching for a Refund or Write Off Request</a> on page 1427
How to create a write off request	<a href="#">Creating a Write Off Request</a> on page 1430

## Adding a Debit Bill to the Write Off Request

### Prerequisites

To add a debit bill to the write off request, you should have:

- Completed bills for the account with one or more debit line items

### Procedure

To add a debit bill to the write off request:

1. Click the **Bills** tab in the **Write Off Request** screen.

The **Bills** tab appears.

- Filter the bills, if required, in the **Search Bills** zone.

**Note:** If a write off request is currently in progress for a debit bill segment or adjustment of a bill, those bills of the account are not listed in the **Search Bills** zone. In addition, a bill with all credit line items are not listed in the **Search Bills** zone.

- Do either of the following:

If...	Then...
A bill has all debit line items and you want to add the debit bill to the write off request	<ol style="list-style-type: none"> <li>In the <b>Search Bills</b> zone, select the bills that you want to write off.</li> <li>Click the <b>Add</b> button available at the upper left corner of the <b>Search Bills</b> zone.</li> </ol> <div style="border: 1px solid black; padding: 2px; margin-top: 5px;"> <p><b>Note:</b> Default adjustment type selected in the write off request type should be non A/P.</p> </div>
A bill has debit balance and one or more credit line items and you want to add the debit bill to the write off request	<ol style="list-style-type: none"> <li>In the <b>Search Bills</b> zone, select the bills that you want to write off.</li> <li>Click the <b>Add</b> button available at the upper left corner of the <b>Search Bills</b> zone.</li> </ol> <div style="border: 1px solid black; padding: 2px; margin-top: 5px;"> <p><b>Note:</b> Default adjustment type selected in the write off request type should be non A/P.</p> </div>

- Click **Add**.

A message appears indicating that the selected bills are added to the write off request.

**Note:** If you select a bill (with credit balance) which contains one or more debit line items or if you select a bill (with debit balance) which contains one or more credit line items, the system will not allow you to add the debit line items by directly adding the bill. In such case, you need to individually select the debit bill segments and adjustments of the bill and then add them to the write off request.

- Click **OK**.

Note that the debit bill segments or adjustments are added in the **Write Off Details** zone on the **Main** tab.

**Note:**  
Irrespective of whether you select a debit bill, or debit bill segments or adjustments, the debit bill segments or adjustments are added in the **Write Off Details** zone. The debit bill is not added to the **Write Off Details** zone.  
The system will not allow you to add a credit line item to the **Write Off Details** zone.

### Related Topics

For more information on...	See...
How to create a write off request	<a href="#">Creating a Write Off Request</a> on page 1430

## Adding a Debit Bill Line Item to the Write Off Request

You can write off the debit bill line items, such as bill segments and adjustments, of the account. While adding a debit bill line item to the write off request, you can either:

- Directly add all debit line items of a bill to the write off request by adding the bill which has all bill segments and adjustments in debit
- Individually add a debit bill segment or adjustment of a bill (with one or more debit line items) to the write off request

### **Prerequisites**

To add a debit bill line item to the write off request, you should have:

- Completed bills for the account with one or more debit line items

### **Procedure**

To add a debit bill line item to the write off request:



1. Click the **Bills** tab in the **Write Off Request** screen.

The **Bills** tab appears.

2. Filter the bills, if required, in the **Search Bills** zone.

**Note:** If a write off request is currently in progress for a debit bill segment or adjustment of a bill, those bills of the account are not listed in the **Search Bills** zone. In addition, a bill with all credit line items are not listed in the **Search Bills** zone.

3. Do any of the following:

If...	Then...
A bill has all debit line items and you want to add a particular debit bill line item to the write off request	<ol style="list-style-type: none"> <li>1. In the <b>Search Bills</b> zone, click the <b>Broadcast</b>  icon corresponding to the bill whose line items you want to view. The <b>Bill Line Items</b> zone appears.</li> <li>2. Select the check box corresponding to the debit bill segment or adjustment that you want to write off.</li> </ol>
A bill has debit balance and one or more credit line items	<ol style="list-style-type: none"> <li>1. In the <b>Search Bills</b> zone, click the <b>Broadcast</b>  icon corresponding to the bill whose line items you want to view. The <b>Bill Line Items</b> zone appears.</li> <li>2. Select the check box corresponding to the debit bill segment or adjustment that you want to write off.</li> </ol>
A bill has credit balance and one or more debit line items	<ol style="list-style-type: none"> <li>1. In the <b>Search Bills</b> zone, click the <b>Broadcast</b>  icon corresponding to the bill whose line items you want to view. The <b>Bill Line Items</b> zone appears.</li> </ol>



If...	Then...
	2. Select the check box corresponding to the debit bill segment or adjustment that you want to write off.

4. Click **Add**.

A message appears indicating that the selected bill segments or adjustments are added to the write off request.

**Note:** If you select a bill (with credit balance) which contains one or more debit line items or if you select a bill (with debit balance) which contains one or more credit line items, the system will not allow you to add the debit line items by directly adding the bill. In such case, you need to individually select the debit bill segments and adjustments of the bill and then add them to the write off request.

5. Click **OK**.

Note that the debit bill segments or adjustments are added in the **Write Off Details** zone on the **Main** tab.

**Note:**

Irrespective of whether you select a debit bill, or debit bill segments or adjustments, the debit bill segments or adjustments are added in the **Write Off Details** zone. The debit bill is not added to the **Write Off Details** zone.

The system will not allow you to add a credit line item to the **Write Off Details** zone.

**Related Topics**

For more information on...	See...
How to create a write off request	<a href="#">Creating a Write Off Request</a> on page 1430

## Editing a Write Off Request

### Prerequisites

To edit a write off request, you should have:

- Adjustment types without A/P request type defined in the application

### Procedure

To edit a write off request:

1. Search for the write off request in the **Refund/Write Off Request** screen.
2. In the **Search Results** section, click the link in the **Refund/Write Off Request Information** column corresponding to the write off request whose details you want to edit.

The **Write Off Request** screen appears.

3. Click the **Edit** button in the **Write Off Request** zone.

The **Edit Write Off Request** screen appears. It contains the following fields:

Field Name	Field Description	Mandatory (Yes or No)
Write Off Request Information	Displays information about the write off request.	Not applicable

Field Name	Field Description	Mandatory (Yes or No)
Account Information	Indicates the account for which the write off request is created.	Not applicable
Comments	Used to specify additional information about the write off request.	No

In addition, this screen contains the following two sections:

- **Characteristics** — Used to define characteristics for the write off request. It contains the following fields:

Field Name	Field Description	Mandatory (Yes or No)
Effective Date	Used to specify the date from when the characteristic is effective for the write off request.	Yes (Conditional) <b>Note:</b> This field is required when you are defining a characteristic for the write off request.
Characteristic Type	Used to indicate the characteristic type. <b>Note:</b> The list includes only those characteristic types where the characteristic entity is set to <b>Refund Write Off Request</b> .	Yes (Conditional) <b>Note:</b> This field is required when you are defining a characteristic for the write off request.
Characteristic Value	Used to specify the value for the characteristic type. <b>Note:</b> On specifying the value for a predefined characteristic type, the description of the characteristic value appears corresponding to the <b>Characteristic Value</b> field.	Yes (Conditional) <b>Note:</b> This field is required when you are defining a characteristic for the write off request.

4. Modify the details of the write off request, if required.
5. Define, edit, or remove characteristics from the write off request, if required.
6. Click **Save**.

The changes made to the write off request are saved.

### **Related Topics**

For more information on...	See...
How to search for a write off request	<a href="#">Searching for a Refund or Write Off Request</a> on page 1427
<b>Write Off Request</b> screen	<a href="#">Write Off Request</a> on page 1467
<b>Write Off Request</b> zone	<a href="#">Write Off Request</a> on page 1468
How to define characteristics for a write off request	<a href="#">Defining Characteristics for a Write Off Request</a> on page 1477

## Editing the Write Off Details

### Prerequisites

To edit the write off details, you should have:

- Adjustment types with A/P request type defined in the application

### Procedure

To edit the write off details:

1. Search for the write off request in the **Refund/Write Off Request** screen.
2. In the **Search Results** section, click the link in the **Refund/Write Off Request Information** column corresponding to the write off request whose bill line item details you want to edit.

The **Write Off Request** screen appears. You can edit the bill line items of the write off request by using either of the following ways:

If...	Then...
Select the bill whose details you want to edit in the <b>Write Off Details</b> zone and click the <b>Edit</b> button available in the upper left corner of this zone.	The <b>Edit Request Details</b> screen appears.
In the <b>Write Off Details</b> zone, click the <b>Broadcast</b>  icon corresponding to the bill whose line items details you want to edit.	The <b>Bill Line Items</b> zone appears. <div style="border: 1px solid black; padding: 5px; margin-top: 10px;"> <p><b>Note:</b> This zone appears only when the Entity Type is <b>Bill</b>.</p> </div> <ol style="list-style-type: none"> <li>1. Select the bill line item whose details you want to edit in the <b>Bill Line Items</b> zone and click the <b>Edit</b> button available in the upper left corner of this zone.</li> </ol> <p>The <b>Edit Request Details</b> screen appears.</p>

**Note:** A bill line item from the write off request can be edited only when the write off request is in the **Draft** status.

The **Edit Request Details** screen appears. It contains the following fields:

Field Name	Field Description	Mandatory (Yes or No)
Request ID	Displays the write off request ID.	Not applicable
Account Information	Displays additional information about the account.	Not applicable
Adjustment Type	Indicates the adjustment type of the write off request type.  You can search for an adjustment type by clicking the <b>Search</b>  icon corresponding to the field.	No

In addition to these fields, this screen contains following columns:





Column Name	Column Description
Entity Type	Indicates the entity type. The valid values are <ul style="list-style-type: none"> <li>• Adjustments</li> <li>• Bill</li> <li>• Bill Segment</li> <li>• Payment Event</li> <li>• Payment</li> </ul>
Entity ID	Displays the entity ID.
Entity Amount	Displays the entity amount.
Currency	Displays the currency in which the entity was created.
Request Amount	Displays the amount that must be write off.
Adjustment Type	Indicates the adjustment type using which the write off adjustment must be created. <div style="border: 1px solid black; padding: 5px; margin-top: 10px;"> <p><b>Note:</b></p> <p>You can search for an account by clicking the <b>Search</b>  icon corresponding to the field.</p> </div>
Bill ID	Displays the bill ID.

In addition to the above columns, the screen has following button:

Button Name	Button Description
Override	Used to override an adjustment type of the write off request.

**Note:**

Pagination is used to display limited number of records in the **Search Results** section. By default, 10 records are displayed in the **Search Results** section. You can change the number of records displayed per page, if required.

You can use the navigation buttons, such as **First** () , **Previous** () , **Next** () , and **Last** () to navigate between pages. You can also select the page to which you want to navigate from the **Go To** list.

The values appear in the **Page Limit** list only when you define values for the **PAGE\_NUMBER** lookup field.

3. Modify the details of the bill line items.
4. Click **Save**.

The changes made to the write off bill line items are saved.

#### Related Topics

For more information on...	See...
<b>Write Off Request</b> screen	<a href="#">Write Off Request</a> on page 1467
<b>Write Off Request</b> zone	<a href="#">Write Off Request</a> on page 1468
How to search for a write off request	<a href="#">Searching for a Refund or Write Off Request</a> on page 1427

## Deleting a Write Off Request

### Procedure

To delete a write off request:

1. Search for the write off request in the **Refund/Write Off Request** screen.
2. In the **Search Results** section, click the link in the **Refund/Write Off Request Information** column corresponding to the write off request that you want to delete.

The **Write Off Request** screen appears.

3. Click the **Delete** button in the **Write Off Request** zone.

A message appears confirming whether you want to delete the write off request.

**Note:** The **Delete** button appears only when the write off request is in the **Draft** status.

4. Click **OK**.

The write off request is deleted.

### Related Topics

For more information on...	See...
How to search for a write off request	<a href="#">Searching for a Refund or Write Off Request</a> on page 1427
<b>Write Off Request</b> screen	<a href="#">Write Off Request</a> on page 1467
<b>Write Off Request</b> zone	<a href="#">Write Off Request</a> on page 1468

## Deleting a Bill from the Write Off Request

### Procedure

To delete a bill from the write off request:

1. Search for the write off request in the **Refund/Write Off Request** screen.
2. In the **Search Results** section, click the link in the **Refund/Write Off Request Information** column corresponding to the write off request whose bill you want to delete.

The **Write Off Request** screen appears.

3. In the **Write Off Details** zone, select the bills and click the **Delete** button available in the upper left corner of this zone.

A message appears confirming whether you want to delete the bill from the write off request.

**Note:** You can delete bill from the write off request only when the request is in the **Draft** status.

4. Click **OK**.

The selected bill gets deleted from the write off request.

### Related Topics

For more information on...	See...
<b>Write Off Request</b> screen	<a href="#">Write Off Request</a> on page 1467
<b>Write Off Request</b> zone	<a href="#">Write Off Request</a> on page 1468
How to search for a write off request	<a href="#">Searching for a Refund or Write Off Request</a> on page 1427

## Deleting a Bill Line Item from the Write Off Request

### **Procedure**

To delete a bill line item from the write off request:

1. Search for the write off request in the **Refund/Write Off Request** screen.
2. In the **Search Results** section, click the link in the **Refund/Write Off Request Information** column corresponding to the write off request whose bill line items you want to delete.

The **Write Off Request** screen appears.

3. In the **Write Off Details** zone, click the **Broadcast**  icon corresponding to the bill whose line items details you want to delete.

The **Bill Line Items** zone appears.

4. In the **Bill Line Items** zone, select the bill line items which you want to delete and click the **Delete** button available in the upper left corner of this zone.

A message appears confirming whether you want to delete the bill line items from the write off request.

**Note:** You can delete a bill line items from the write off request only when the request is in the **Draft** status.

5. Click **OK**.

The selected bill line items gets deleted from the write off request.

### **Related Topics**

For more information on...	See...
<b>Write Off Request</b> screen	<a href="#">Write Off Request</a> on page 1467
<b>Write Off Request</b> zone	<a href="#">Write Off Request</a> on page 1468
How to search for a write off request	<a href="#">Searching for a Refund or Write Off Request</a> on page 1427

## Submitting a Write Off Request

### **Prerequisites**

To submit a write off request, you should have:

- Debit bill line items added in the write off request

### **Procedure**

To submit a write off request:

1. Search for the write off request in the **Refund/Write Off Request** screen.

2. In the **Search Results** section, click the link in the **Refund/Write Off Request Information** column corresponding to the write off request that you want to submit.

The **Write Off Request** screen appears.

3. Click the **Submit** button in the **Write Off Request** zone.

The system behaves in the following manner:

If...	Then
The <b>Approval Required</b> and <b>Hierarchical Approval</b> check boxes are selected in the write off request type using which the write off request is created	A To Do of the <b>C1-WOREQ</b> To Do type is created and sent to the approver at the first level in the approval hierarchy, and the status of the write off request is changed to <b>Approval In Progress</b> .
The <b>Approval Required</b> check box is selected, but the <b>Hierarchical Approval</b> check box is not selected in the write off request type using which the write off request is created	A To Do of the <b>C1-WOREQ</b> To Do type is created and sent to the approver at the hierarchy level where the total write off amount falls within the threshold limit. In addition, the status of the write off request is changed to <b>Approval In Progress</b> .
The <b>Approval Required</b> check box is not selected in the write off request type using which the write off request is created	<p>The write off adjustments are created using the specified adjustment types and the status of the write off request is changed to <b>Processed</b>.</p> <div data-bbox="889 873 1468 1310" style="border: 1px solid black; padding: 5px;"> <p><b>Note:</b> The write off adjustments are created in the <b>Frozen</b> status. If a match event is present for the debit bill line items (such as bill segments and adjustments), the existing match event is stamped on the write off adjustments and on the corresponding financial transactions. However, if the match events does not exist, a new match event is created and stamped on the write off adjustments and on the corresponding financial transactions. If you are doing a partial write off for any entity, the corresponding match event status is set to <b>Open</b>. However, if the entire eligible amount is written off, the corresponding match event status is set to <b>Balanced</b>.</p> </div>
The total write off amount is less than the minimum threshold amount	<p>The write off request is automatically approved by the system and write off adjustments are created using the specified adjustment types. In addition, the status of the write off request is changed to <b>Processed</b>.</p> <div data-bbox="889 1478 1468 1906" style="border: 1px solid black; padding: 5px;"> <p><b>Note:</b> The write off adjustments are created in the <b>Frozen</b> status. If a match event is present for the debit bill line items (such as bill segments and adjustments), the existing match event is stamped on the write off adjustments and on the corresponding financial transactions. However, if the match events does not exist, a new match event is created and stamped on the write off adjustments and on the corresponding financial transactions. If you are doing a partial write off for any entity, the corresponding match event status is set to <b>Open</b>. However, if the entire eligible amount is written off, the corresponding match event status is set to <b>Balanced</b>.</p> </div>

**Note:** The **Submit** button appears only when the write off request is in the **Draft** status.

### Related Topics

For more information on...	See...
How to search for a write off request	<a href="#">Searching for a Refund or Write Off Request</a> on page 1427
<b>Write Off Request</b> screen	<a href="#">Write Off Request</a> on page 1467
<b>Write Off Request</b> zone	<a href="#">Write Off Request</a> on page 1468

## Approving a Write Off Request

You can view the number of write off requests which are pending for approval in the **Refund/Write Off Request** screen. The approver can review, and accordingly approve or reject the write off request based on the observations.

**Note:** The system will not allow you to approve or reject a write off request submitted by you.

### Procedure

To approve a write off request:

1. Do either of the following:

If you want to...	Then...
Approve a write off request through the <b>Refund/Write Off Request</b> screen	<ol style="list-style-type: none"> <li>1. Search for the write off request in the <b>Refund/Write Off Request</b> screen.</li> <li>2. In the <b>Search Results</b> section, click the link in the <b>Refund/Write Off Request Information</b> column corresponding to the write off request which you want to review.</li> </ol>
Approve a write off request from the <b>To Do List</b> screen	<ol style="list-style-type: none"> <li>1. Click the <b>Menu</b> link in the <b>Application</b> toolbar. A list appears.</li> <li>2. From the <b>Main</b> menu, select <b>To Do</b> and then click <b>To Do List</b>. The <b>To Do Type for User Search</b> window appears.</li> <li>3. Enter <b>C1-WOREQ</b> in the <b>To Do Type</b> field.</li> <li>4. Click the <b>Search</b> button corresponding to the <b>To Do Type</b> field. The <b>To Do List</b> screen appears.</li> <li>5. Select the <b>Open</b> option from the <b>Filter by</b> list to view all unassigned To Dos.</li> </ol>



If you want to...	Then...
	6. Click the link in the <b>Message</b> column corresponding to the To Do of the write off request that you want to review.

The **Write Off Request** screen appears.

2. Review the write off request details.
3. Click the **Approve** button in the **Write Off Request** zone.

The system behaves in the following manner:

If...	Then...
The <b>Hierarchical Approval</b> check box is selected in the write off request type using which the write off request is created and the total write off amount is greater than the threshold amount specified at the next level in the approval hierarchy	A To Do of the <b>C1-WOREQ</b> To Do type is created and sent to the approver at the next level in the approval hierarchy, and the status of the write off request remains as <b>Approval In Progress</b> .
The <b>Hierarchical Approval</b> check box is selected in the write off request type using which the write off request is created and the total write off amount is less than the threshold amount specified at the next level in the approval hierarchy	<p>The write off adjustments are created using the specified adjustment types and the status of the write off request is changed to <b>Processed</b>.</p> <div style="border: 1px solid black; padding: 5px;"> <p><b>Note:</b> The write off adjustments are created in the <b>Frozen</b> status. If a match event is present for the debit bill line items (such as bill segments and adjustments), the existing match event is stamped on the write off adjustments and on the corresponding financial transactions. However, if the match events does not exist, a new match event is created and stamped on the write off adjustments and on the corresponding financial transactions. If you are doing a partial write off for any entity, the corresponding match event status is set to <b>Open</b>. However, if the entire eligible amount is written off, the corresponding match event status is set to <b>Balanced</b>.</p> </div>
The <b>Hierarchical Approval</b> check box is not selected in the write off request type using which the write off request is created	<p>The write off adjustments are created using the specified adjustment types and the status of the write off request is changed to <b>Processed</b>.</p> <div style="border: 1px solid black; padding: 5px;"> <p><b>Note:</b> The write off adjustments are created in the <b>Frozen</b> status. If a match event is present for the debit bill line items (such as bill segments and adjustments), the existing match event is stamped on the write off adjustments and on the corresponding financial transactions. However, if the match events does not exist, a new match event is created and stamped on the write off adjustments and on the corresponding financial transactions. If you are doing a partial write off for any entity, the corresponding match event status is set to <b>Open</b>. However, if the entire eligible amount is written off, the corresponding match event status is set to <b>Balanced</b>.</p> </div>

**Note:** The **Approve** button appears only when:

- The write off request is in the **Approval In Progress** status.
- A user with the approval To Do role is reviewing the write off request.

### **Related Topics**

<b>For more information on...</b>	<b>See...</b>
How to search for a write off request	<a href="#">Searching for a Refund or Write Off Request</a> on page 1427
<b>Write Off Request</b> screen	<a href="#">Write Off Request</a> on page 1467
<b>Write Off Request</b> zone	<a href="#">Write Off Request</a> on page 1468

## **Rejecting a Write Off Request**

### **Prerequisites**

To reject a write off request, you should have:

- Rejection reasons defined in the application

### **Note:**

While rejecting a write off request, you need to specify the reason why you want to reject the write off request. You can select the appropriate rejection reason only when you have defined the reasons for the **Rejected** status of the **C1-WORequest** business object in the **Status Reason** screen.

The system will not allow you to approve or reject a write off request submitted by you.

### **Procedure**

To reject a write off request:

1. Do either of the following:

<b>If you want to...</b>	<b>Then...</b>
Reject a write off request through the <b>Refund/Write Off Request</b> screen	<ol style="list-style-type: none"> <li>1. Search for the write off request in the <b>Refund/Write Off Request</b> screen.</li> <li>2. In the <b>Search Results</b> section, click the link in the <b>Refund/Write Off Request Information</b> column corresponding to the write off request which you want to review.</li> </ol>
Reject a write off request from the <b>To Do List</b> screen	<ol style="list-style-type: none"> <li>1. Click the <b>Menu</b> link in the <b>Application</b> toolbar. A list appears.</li> <li>2. From the <b>Main</b> menu, select <b>To Do</b> and then click <b>To Do List</b>.  The <b>To Do Type for User Search</b> window appears.</li> </ol>

If you want to...	Then...
	<ol style="list-style-type: none"> <li>3. Enter <b>C1-WOREQ</b> in the <b>To Do Type</b> field.</li> <li>4. Click the <b>Search</b> button corresponding to the <b>To Do Type</b> field. The <b>To Do List</b> screen appears.</li> <li>5. Select the <b>Open</b> option from the <b>Filter by</b> list to view all unassigned To Dos.</li> <li>6. Click the link in the <b>Message</b> column corresponding to the To Do of the write off request that you want to review.</li> </ol>

The **Write Off Request** screen appears.

2. Review the write off request details.
3. Click the **Reject** button in the **Write Off Request** zone.

The **Reject Write Off Request** window appears. It contains following fields:

Field Name	Field Description	Mandatory (Yes or No)
Status Reason	Used to indicate the reason why you want to reject the write off request.	Yes
Comments	Used to specify additional information while rejecting the write off request.	No

**Note:** The **Reject** button appears only when:

- The write off request is in the **Approval In Progress** status.
- A user with the approval To Do role is reviewing the write off request.

4. Select the rejection reason from the **Status Reason** list.
5. Click **Save**.

The status of the write off request is changed to **Rejected**.

### Related Topics

For more information on...	See...
How to search for a write off request	<a href="#">Searching for a Refund or Write Off Request</a> on page 1427
<b>Write Off Request</b> screen	<a href="#">Write Off Request</a> on page 1467
<b>Write Off Request</b> zone	<a href="#">Write Off Request</a> on page 1468

## Viewing the Log of a Write Off Request

### Procedure

To view the log of a write off request:

1. Search for the write off request in the **Refund/Write Off Request** screen.
2. In the **Search Results** section, click the link in the **Refund/Write Off Request Information** column corresponding to the write off request whose log you want to view.

The **Write Off Request** screen appears. It consists of the following tabs:

- **Main** – Displays information about the write off request. It contains the following zones:
  - **Write Off Request** – Displays the details of the write off request.
  - **Write Off Details** – Lists the debit bill line items (such as debit bill segments and adjustments) of the account which must be written off.
  - **Bill Line Items** — Displays the details of the bill which must be written off.

**Note:**

This zone appears when you click the Broadcast  icon corresponding to the entity type as **Bill** in the **Write Off Details** zone.

- **Bills** — Used to search bills with debit line items, such as debit bill segments and adjustments, that you want to write off. This tab appears only when the write off request is in the **Draft** status.
  - **Log** – Lists the complete trail of actions performed on the write off request.
3. Click the **Log** tab
  4. View the log of the write off request in the **Write Off Request Log** zone.

**Note:** You can manually add a log entry for the write off request by clicking the **Add Log Entry** link in the upper right corner of the **Write Off Request Log** zone.

### Related Topics

For more information on...	See...
How to search for a write off request	<a href="#">Searching for a Refund or Write Off Request</a> on page 1427
How to add a log entry for a write off request	<a href="#">Adding a Log Entry for a Write Off Request</a> on page 1492
<b>Write Off Request Log</b> zone	<a href="#">Write Off Request Log</a> on page 1474

## Adding a Log Entry for a Write Off Request

### Procedure

To add a log entry for a write off request:

1. Search for the write off request in the **Refund/Write Off Request** screen.
2. In the **Search Results** section, click the link in the **Refund/Write Off Request Information** column corresponding to the write off request whose log you want to edit.

The **Write Off Request** screen appears. It consists of the following tabs:

- **Main** – Displays information about the write off request. It contains the following zones:
  - **Write Off Request** – Displays the details of the write off request.
  - **Write Off Details** – Lists the debit bill line items (such as debit bill segments and adjustments) of the account which must be written off.

- **Bills** — Used to search bills with debit line items, such as debit bill segments and adjustments, that you want to write off. This tab appears only when the write off request is in the **Draft** status.
  - **Log** – Lists the complete trail of actions performed on the write off request.
3. Click the **Log** tab.

The **Log** tab appears.

4. Click the **Add Log Entry** link in the upper right corner of the **Write Off Request Log** zone.

The **Add Request Log** window appears. It contains the following fields:

Field Name	Field Description	Mandatory (Yes or No)
Request Information	Displays information about the write off request.	Not applicable
Log Details	Used to specify additional comments on the write off request.	Yes

5. Enter the comments in the **Log Details** field.
  6. Click **Save**.
- The log entry is added in the **Write Off Request Log** zone.

### **Related Topics**

For more information on...	See...
How to search for a write off request	<a href="#">Searching for a Refund or Write Off Request</a> on page 1427

## **Canceling a Write Off Request**

There might be situations when incorrect write off request is processed in the system. In such case, the system provides you with an ability to cancel the write off request. However, note that you can cancel a write off request only when the write off request is in the **Processed** status.

### **Prerequisites**

To cancel a write off request, you should have:

- Cancel reasons defined in the application

**Note:** While cancelling a write off request, you need to specify the reason why you want to cancel the write off request. You can select the appropriate cancel reason only when you have defined the reasons for the **Cancelled** status of the **C1-WORequest** business object in the **Status Reason** screen.

### **Procedure**

To cancel a write off request:

1. Search for the write off request in the **Refund/Write Off Request** screen.
2. In the **Search Results** section, click the link in the **Refund/Write Off Request Information** column corresponding to the write off request that you want to cancel.

The **Write Off Request** screen appears.

3. Click the **Cancel** button in the **Write Off Request** zone.

The **Cancel Reason** window appears. It contains the following fields:

Field Name	Field Description	Mandatory (Yes or No)
Status Reason	Used to indicate the reason why you want to cancel the write off request.	Yes
Comments	Used to specify additional information while cancelling the write off request.	No

**Note:** The **Cancel** button appears only when the write off request is in the **Processed** status.

4. Select the cancel reason from the **Status Reason** list.
5. Click **Save**.

The status of the write off request is changed to **Cancelled**.

**Note:** The **C1-WOCANCEL** algorithm cancels all the frozen adjustments created for the write off request which is in the **Processed** state.

### Related Topics

For more information on...	See...
How to search for a write off request	<a href="#">Searching for a Refund or Write Off Request</a> on page 1427
<b>Write Off Request</b> screen	<a href="#">Write Off Request</a> on page 1467
<b>Write Off Request</b> zone	<a href="#">Write Off Request</a> on page 1468

---

# Chapter 22

---

## Hold Request

---

### Topics:

- [Hold Request \(Without Approval\) Status Transition](#)
- [Hold Request \(With Approval\) Status Transition](#)
- [Algorithms Used in C1-HoldRequest](#)
- [Prerequisites](#)
- [Hold Request Type](#)
- [Hold Request \(Used for Searching\)](#)
- [Hold Request \(Used for Viewing\)](#)

Oracle Revenue Management and Billing allows you to hold the amount for Person, Account or Bills. Hold is a way to prevent certain types of activities from taking place for a customer over a given period of time. The activities that need to be on Hold vary according to the reason for hold, such as due to a climate disaster the collection activity remains on Hold until disaster period is over.

Hold Request is a object which contains list of processes to be kept on hold for certain entities such as account, person, and bill for certain period of time. The hold period is defined as the duration between Hold Request Start Date and End Date. Each Hold Request contains an entity and processes on hold. There could exists multiple hold requests for an entity for different hold reasons and processes.

Following are the hold request entities:

- **Person:** If the person is on hold then all entities linked to that person where the person is financially responsible, such as accounts and its bills will be on hold.
- **Account:** If the account is on hold then all the bills of that account will be on hold.
- **Bill:** A bill will be on complete or partial hold.

In Hold Request, following mentioned processes can be on hold:

- **Auto Pay** — If the auto payment process is on hold then, then auto pay for the bills of the account added in hold request will be on hold till the request is released. However, you can do the manual payments. On activation of the hold request, **Defer Auto Pay Date** field (in Account screen) is populated with some future date. If billing process is on hold then auto payment process would also go on hold.
- **Bill Generation** — If the bill generation process is on hold then, then new bills will not be created for the account added in hold request till request is released. On activation of the hold request, **Bill After** date field (in Account screen) is populated with either hold request end date or some future date until that date billing is kept on hold. Whenever hold request is released for billing process then **Bill After** date field will be populated as system date.

**Note:** During the tenure of a hold request if customer does not require pending bills to be used for bill generation, bill in pending for accounts under hold are identified during activation of hold request which can be deleted by execution of the **C1-DELBI** batch . For more information about the batch, refer to *Oracle Revenue Management and Billing Batch Guide*

- **Overdue** — If the overdue process is on hold then bills associated with accounts in the hold request will be on hold for overdue process. It means existing overdue will be cancelled. New overdue process will get created once hold request is released. On activation of the hold request, **Postpone Credit Review** field (in Account screen) is populated with either hold request end date or some future date. When hold request is released, **Postpone Credit Review** field would be set as system date. If the overdue process is on hold then request for policy termination due to non payment will be on hold.
- **Funding** — A list of bills identified for a full bill amount or a partial bill amount will be kept on hold for a funding process.

**Note:**

For Funding process, Person, Bill, and Account entities can be put on hold. However, for processes like Auto pay, Bill Generation, and Overdue, only Account entity can be put on hold.

Processes and Entities start dates and end dates are expected to be within the limit of Hold Request Start Date and End Date.

You need to specify the hold request type while creating a hold request. Hold request type helps the system to determine:

- Whether to allow the partial hold for bill or not
- Whether hold request must be approved by the approver before keeping entities and processes on hold

It is possible for a given entity, such as a person or account, to be affected by hold request with differing periods or at differing levels. For example, if there is a hold request added for a person manually and another hold request is there due to some other reason for an account belongs to the person who is already on hold. The system assumes that both hold requests are in effect for the account and that the period of accounts starts from the start of the earlier hold request record (for the account) until the later of the two release dates.

During the hold request process, a hold request goes through various statuses in its lifecycle. For more information about the hold request statuses, see [Hold Request \(Without Approval\) Status Transition](#) on page 1497 and [Hold Request \(With Approval\) Status Transition](#) on page 1497

Note that the lifecycle of a hold request is driven by the business object using which the hold request is created. A hold request business object named **C1-HoldRequest** is shipped with the product. The hold request feature explained in this document is articulated based on the lifecycle and logic defined in the **C1-HoldRequest** business object. In addition, you can configure the search feature by setting **Fkref** feature configuration for each entity, such as person, account and bill.

For more information on how to setup the hold request processes, see [Prerequisites](#) on page 1504.



## Hold Request (Without Approval) Status Transition

The following figure graphically indicates how a hold request moves from one status to another when approval workflow is off:

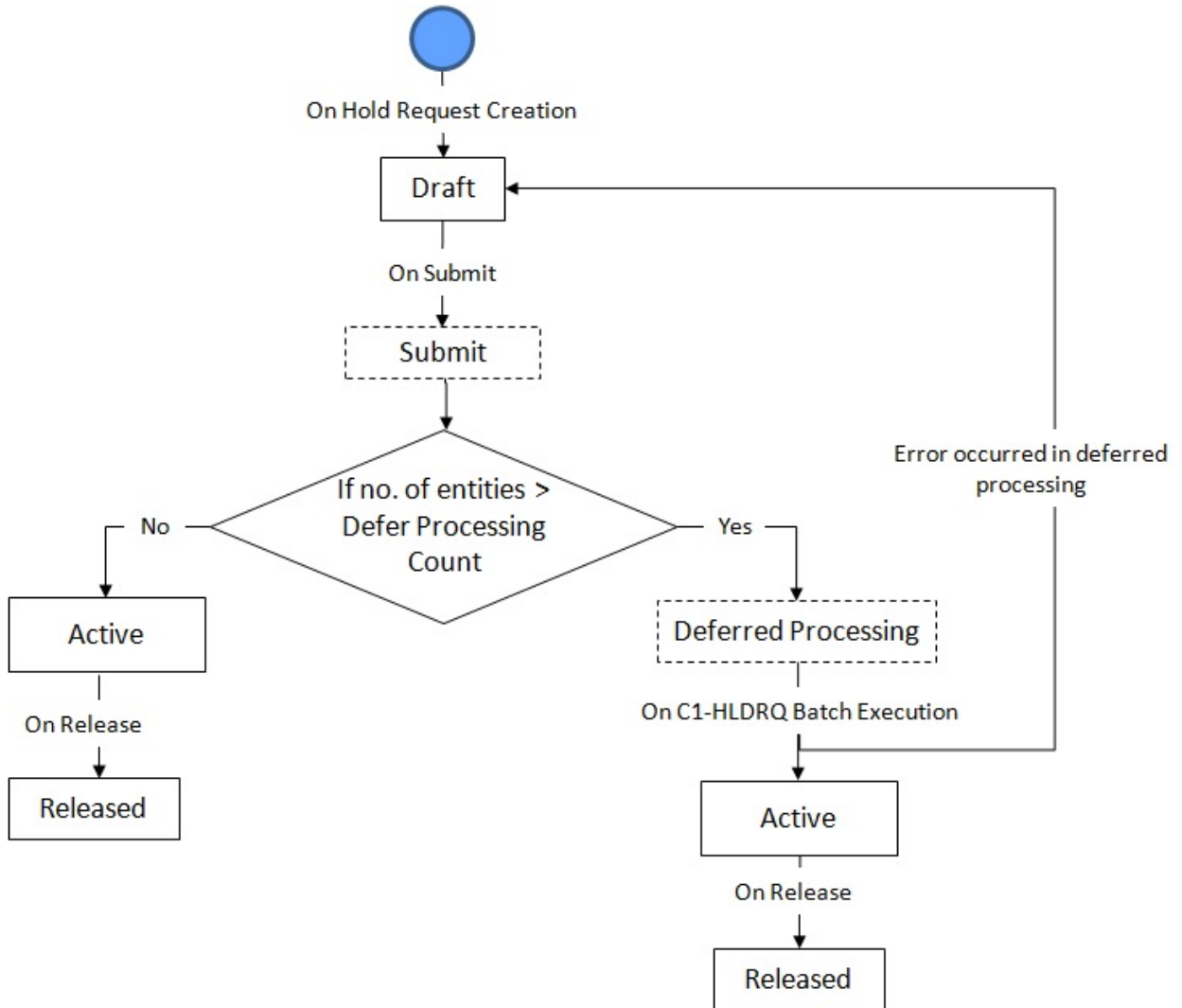

## Hold Request (With Approval) Status Transition

The following figure graphically indicates how a hold request moves from one status to another when approval workflow is on:

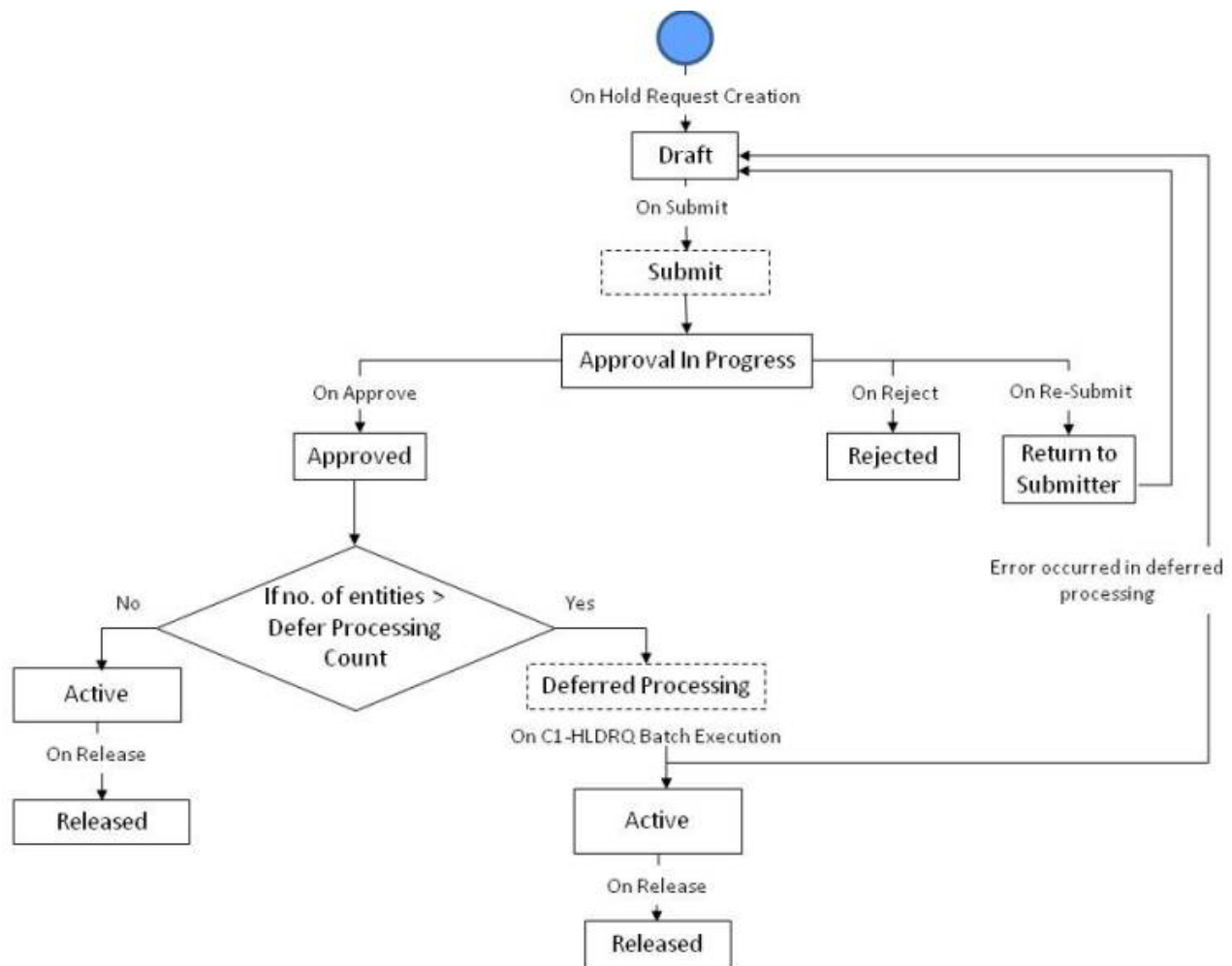

## Algorithms Used in C1-HoldRequest

The following table lists the algorithms which are attached to the **C1-HoldRequest** business object:

System Event	Algorithm	Algorithm Type	Description
Information	C1-HOLD-INF	C1-HOLD-INF	<p>This algorithm generates hold request information string which appears throughout the application. This algorithm concatenates the following fields:</p> <ul style="list-style-type: none"> <li>• Hold Request Type</li> <li>• Status</li> <li>• Entity</li> <li>• Hold Request ID</li> </ul>

System Event	Algorithm	Algorithm Type	Description
Validation	C1-HLDVALDN	C1-HLDVALDN	<p>This algorithm validates following during different statuses:</p> <p>For <b>Draft</b> status, it checks the following:</p> <ul style="list-style-type: none"> <li>• At least one Process is present in the request. Entity selection is optional</li> <li>• No duplicate entity and process is allowed in a single request.</li> <li>• Same entity cannot be placed on hold with the same <b>Hold Reason</b> in multiple Hold Requests.</li> <li>• Request start date is earlier than or equal to process and entity start date.</li> <li>• Request End Date is later than or equal to process and entity end date.</li> <li>• At least one process start date is earlier than or equal to any entity start date.</li> <li>• At least one process end date is later than or equal to any entity end date.</li> <li>• For Bill and Person entity, <b>Bill Generation</b>, <b>Overdue</b>, and <b>Auto Pay</b> processes cannot be selected as the hold processes in a hold request.</li> <li>• For Bill entity, it checks if hold amount is less than or equal to bill outstanding amount</li> <li>• For Bill entity, to add a new bill to the request, the selected bill should be with a non-zero outstanding amount.</li> <li>• Each Entities start date should lie within at least one process start date and end date in a request.</li> </ul> <p>For <b>Active</b> state following are some additional validations:</p> <ul style="list-style-type: none"> <li>• Hold Process or Entities cannot be deleted.</li> <li>• Hold Request or Entity or Process Start Date cannot be modified.</li> <li>• Hold Reason cannot be modified</li> <li>• Hold Request or Process or Entity End Date can be updated as either equal or greater than system date.</li> <li>• Process can be added with start date as system date.</li> <li>• Entity cannot be added in hold request.</li> <li>• If entity or process end date is in past then it cannot be updated.</li> </ul>

The following table lists the algorithms which are used in the lifecycle of the **C1-HoldRequest** business object:

Status	System Event	Algorithm	Algorithm Type	Description
Draft	Enter	C1-HLDARCTRN	C1-HLDARCTRN	This algorithm transitions the request to active status when the request is created from <b>Account Receivable Central</b> and <b>Delinquency Control</b> .
Draft	Exit	F1-TODOCOMPL	F1-TODOCOMPL	This algorithm type completes To Do entries that are linked to an object when the object exits a given state. The system finds all open To Do entries with drill keys for primary key of the current business object, and completes them, unless the To Do entry's type has been configured with an Exclude To Do Type Characteristic Type indicating that it should not be automatically completed.
Submit	Enter	C1-HOLDSUBMT	C1-HOLDSUBMT	This algorithm checks the following: <ul style="list-style-type: none"> <li>Whether the approval is required for the hold request. If the approval is required for a hold request, the status of the hold request is changed to <b>Approval In Progress</b>. However, if the approval is not required for a hold request, the status of the hold request is changed to <b>Active</b> or <b>Deferred Processing</b> depending on the Defer Processing Count specified in the hold request type.</li> </ul>

Status	System Event	Algorithm	Algorithm Type	Description
Active	Enter	C1-HOLDACTV	C1-HOLDACTV	<p>This algorithm is invoked on Active button and validates following:</p> <ul style="list-style-type: none"> <li>• Entities Start Date is on or after Hold Request Start Date</li> <li>• Entities End Date is on or before Hold Request End Date</li> <li>• For an Entity Bill, Hold Amount is not more than bill outstanding amount or Bill outstanding amount is not equal to zero.</li> <li>• Updates and processes entities start date to system date.</li> <li>• It updates following mentioned date to minimum of Entity End Date or Process End Date: <ul style="list-style-type: none"> <li>• Bill After Date - For Bill Generation Process.</li> <li>• Postpone Credit review Date Until- For Overdue Process.</li> <li>• Defer Auto Pay Date - For Auto pay process.</li> </ul> </li> <li>• <b>Parameter-Alert Type</b>-Using this Alert Type alerts are shown in the dashboard. A alert will have hyperlink which will enable user to navigate to <b>Alerts</b> tab on account.</li> <li>• Start Dates and End Dates of Alert types are maintained based on the Hold Requests associated with the account.</li> </ul> <div style="border: 1px solid black; padding: 5px; margin-top: 10px;"> <p><b>Note:</b> If entity end date is empty, process end date will be considered. If process end date and entity is empty, Hold Request End Date will be considered.</p> </div>

Status	System Event	Algorithm	Algorithm Type	Description
Deferred Processing	Monitor	F1-AT-RQJ	F1-AT-RQJ	This algorithm type transitions business object current state to the input Next Status or to the status related to the input Next Transition Condition. Only one of the soft parameters may be specified. If both soft parameters are not specified, the business object will be transitioned to the default next status specified on lifecycle. Algorithms of this algorithm type may be defined for any business object status as its monitor algorithm.
Approval In Progress	Enter	C1-HOLDAPP	C1-HOLDAPP	This algorithm creates To Do based on 'Approval To Do Type configured in Hold Request Type.
Approval In Progress	Exit	F1-TODOCOMPL	F1-TODOCOMPL	This algorithm type completes To Do entries that are linked to an object when the object exits a given state. The system finds all open To Do entries with drill keys for the current business object's primary key, and completes them, unless the To Do entry's type has been configured with an Exclude To Do Type Characteristic Type indicating that it should not be automatically completed.
Approved	Enter	C1-HOLDAPRVD	C1-HOLDAPRVD	This algorithm is triggered when the approver clicks the <b>Approve</b> button. It checks whether the approval is required from users at the next level in the approval profile hierarchy. If the approval is required from the next level in the approval hierarchy, the status of the hold request is changed to <b>Approval In Progress</b> . If further approval is not required, the status of the hold request is changed to <b>Active</b> or <b>Deferred Processing</b> depending on the Defer Processing Count specified in the hold request type.

Status	System Event	Algorithm	Algorithm Type	Description
Return to Submitter	Enter	C1-HLDRESUBM	C1-HLDRESUBM	This algorithm is triggered when the approver clicks the <b>Re Submit</b> button. A To Do is created and sent to the submitter. It transitions the status of the hold request from <b>Approval In Progress</b> to <b>Draft</b> . The submitter can make required changes to the request details and submit it again. The To Do Type and To Do Role for submitter is specified in hold request type.
Rejected	-	-	-	-
Released	Enter	C1-RELENTITY	C1-RELENTITY	This algorithm is invoked on <b>Release</b> button and updates following date to system date for all entities in the Hold Request: <ul style="list-style-type: none"> <li>• Bill After Date - For Bill Generation Process</li> <li>• Postpone Credit review Date Until- For Overdue Process</li> <li>• Defer Auto Pay Date - For Auto pay process</li> <li>• Parameter-Alert Type-Using this Alert Type alerts are shown in the dashboard. A alert will have hyperlink which will enable user to navigate to Alerts tab on account</li> <li>• Start Dates and End Dates of Alert types are maintained based on the Hold Requests associated with the account.</li> </ul>
Released	Enter	C1-RLSHOLD	C1-RLSHOLD	This algorithm is invoked on click of <b>Release</b> button in hold request and updates the following: <ul style="list-style-type: none"> <li>• Hold Request End Date is updated to System Date</li> <li>• Processes End Date is updated to System Date</li> <li>• Entities End Date is updated to System Date</li> <li>• Hold request status is changed to <b>Released</b> after <b>Hold Release Reason</b> is accepted.</li> </ul>

## Prerequisites

---

To setup the hold request process, you need to do the following:

- Define the release status reasons for the **C1-HoldRequest** business object
- Define the required hold reasons in the system
- Define rejected status reasons for the **C1-HoldRequest** business object
- Assign the **C1-HLDAP** To Do type to a To Do role whose users must receive To Do generated while submitting a hold request for approval
- Assign the **C1-HOLSB** To Do type to a To Do role whose users must receive To Do generated while resubmitting a hold request
- Define the required hold request types in the system
- Define the required characteristic types where the characteristic entity is set to **Hold Request**
- Define the required characteristic types where the characteristic entity is set to **Hold Request Type**
- Set the batch control type of the **Hold Request Periodic Monitor (C1-HLDRQ)** and **Hold Request Monitor (C1-HLMON)** batches to Timed and define the following attributes:
  - Time Interval
  - Timer Active
  - User ID
  - Batch Language
  - Email Address

**Note:** For more information about the batch, refer to *Oracle Revenue Management and Billing Batch Guide*

## Hold Request Type

---

Oracle Revenue Management and Billing allows you to define a hold request type using which you can create a hold request.

The **Hold Request Type** screen allows you to define, edit, copy, and delete a hold request type. This screen consists of the following zones:

- [Hold Request Type List](#) on page 1504
- [Hold Request Type](#) on page 1505

### Hold Request Type List

The **Hold Request Type List** zone lists hold request types that are already defined in the system. It contains the following columns:

Column Name	Column Description
Hold Request Type	Displays the hold request type.
Description	Displays the description of the hold request type.



Column Name	Column Description
Edit	On clicking the <b>Edit</b> (✎) icon, the <b>Hold Request Type</b> screen appears where you can edit the details of the hold request type.
Duplicate	On clicking the <b>Duplicate</b> (📄📄) icon, the <b>Hold Request Type</b> screen appears where you can define a hold request type using an existing hold request type.
Delete	On clicking the <b>Delete</b> (🗑) icon, you can delete the hold request type.  <b>Note:</b> You can delete a hold request type only when you have not created a hold request using the hold request type.

On clicking the **Broadcast** (📡) icon corresponding to the hold request type, the **Hold Request Type** zone appears with the details of the respective hold request type.

### Related Topics

For more information on...	See...
How to define a hold request type	<a href="#">Defining a Hold Request Type</a> on page 1507
How to edit a hold request type	<a href="#">Editing a Hold Request Type</a> on page 1511
How to copy a hold request type	<a href="#">Copying a Hold Request Type</a> on page 1514
How to delete a hold request type	<a href="#">Deleting a Hold Request Type</a> on page 1513
How to view the details of a hold request type	<a href="#">Viewing the Hold Request Type Details</a> on page 1517

## Hold Request Type

The **Hold Request Type** zone displays the details of the hold request type. This zone consists of the following sections:

- **Main** — This section provides basic information about the hold request type. It contains the following fields:

Field Name	Field Description
Hold Request Type	Displays the hold request type.
Description	Displays the description of the hold request type.
Hold Request Business Object	Indicates the business object that will be used to create the hold request.  <b>Note:</b> It has a link. On clicking the link, the <b>Business Object</b> screen appears where you can view the details of the respective business object.
Detailed Description	Displays additional information about the hold request type.
Status	Indicates the status of the hold request type. The valid values are: <ul style="list-style-type: none"> <li>• Active</li> <li>• Inactive</li> </ul>
Allow Partial Hold for Bill	Indicates whether the partial hold amount is allowed for a bill.

Field Name	Field Description
Defer Processing Count	<p>Displays the number of entities to determine if the hold request will be processed in deferred mode.</p> <p><b>Note:</b> If the number of entities is less than the <b>Defer Processing Count</b>, the hold request will be processed in real time (i.e. immediately).</p>
Approval Required	Indicates whether approval is required while creating the hold request using hold request type.
Approval To Do Type	<p>Indicates that To Do of the specified To Do type must be created when you submit the hold request for approval.</p> <p><b>Note:</b> This field appears only when the <b>Approval Required</b> check box is selected. It has a link. On clicking the link, the <b>To Do Type</b> screen appears with the details of the respective To Do type.</p>
Approval To Do Role	<p>Indicates that users with the specified To Do role can only approve the hold request submitted for approval.</p> <p><b>Note:</b> This field appears only when the <b>Approval Required</b> check box is selected. It has a link. On clicking the link, the <b>To Do Role</b> screen appears where you can view the details of the respective To Do role.</p>
Submitter To Do Type	<p>Indicates the To Do type of the submitter.</p> <p><b>Note:</b> It has a link. On clicking the link, the <b>To Do Type</b> screen appears where you can view the details of the respective To Do type.</p>
Submitter To Do Role	<p>Indicates the To Do role of the submitter.</p> <p><b>Note:</b> It has a link. On clicking the link, the <b>To Do Role</b> screen appears where you can view the details of the respective To Do role.</p>

- **Hold Processes** —This section displays the list of processes to be kept on hold for the hold request type.
- **Characteristics** — This section lists the characteristics defined for the hold request type. It contains the following columns:

Column Name	Column Description
Characteristic Type	Indicates the characteristic type.
Characteristic Value	Displays the value of the characteristic type.

- **Record Actions** — This section contains the following buttons:

Button Name	Button Description
Edit	Used to edit the details of the hold request type.
Delete	Used to delete the hold request type. <b>Note:</b> You can delete a hold request type only when you have not created a hold request using the hold request type.
Duplicate	Used to create a new hold request type using an existing hold request type.

- **Record Information** — This section contains the following fields:

Field Name	Field Description
Business Object	Indicates the business object using which the hold request type is created. In addition, a context menu appears corresponding to this field which helps in navigating to other screens in the application. <b>Note:</b> It has a link. On clicking the link, the <b>Business Object</b> screen appears where you can view the details of the respective business object.

By default, the **Hold Request Type** zone does not appear in the **Hold Request Type** screen. It appears only when you click the **Broadcast**  icon corresponding to the hold request type in the **Hold Request Type List** zone.

### **Related Topics**

For more information on...	See...
How to define a hold request type	<a href="#">Defining a Hold Request Type</a> on page 1507
How to edit a hold request type	<a href="#">Editing a Hold Request Type</a> on page 1511
How to copy a hold request type	<a href="#">Copying a Hold Request Type</a> on page 1514
How to delete a hold request type	<a href="#">Deleting a Hold Request Type</a> on page 1513
How to view the details of a hold request type	<a href="#">Viewing the Hold Request Type Details</a> on page 1517

## **Defining a Hold Request Type**

### **Prerequisites**

To define a hold request type, you should have:

- Hold request business objects defined in the application

### **Procedure**

To define a hold request type:

1. Click the **Admin** link in the **Application** toolbar.  
A list appears.
2. From the **Admin** menu, select **H** and then click **Hold Request Type**.  
A sub-menu appears.
3. Click the **Add** option from the **Hold Request Type** sub-menu.

The **Select Business Object** screen appears. It contains the following fields:

Field Name	Field Description	Mandatory (Yes or No)
Hold Request Type Business Object	Used to indicate the business object that you want to use to create the hold request type.	Yes

**Tip:** Alternatively, you can access the **Select Business Object** screen by clicking the **Add** button in the **Page Title** area of the **Hold Request Type** screen.

**Note:** The **Select Business Object** screen appears only when there are multiple hold request type business objects defined in the application. If there is only one hold request type business object defined in the application, the **Hold Request Type** screen appears.

- Select the required hold request type business object from the respective field.
- Click **OK**.

The **Hold Request Type** screen appears. It contains the following sections:

- **Main** — Used to specify basic details about the hold request type.
- **Hold Processes** — Used to define the processes to hold for the hold request type.
- **Characteristics** — Used to define characteristics for the hold request type.

The **Main** section contains the following fields:

Field Name	Field Description	Mandatory (Yes or No)
Hold Request Type	Used to specify the hold request type.	Yes
Business Object	Indicates the hold request type business object used while defining the hold request type.	Not applicable
Description	Used to specify the description for the hold request type.	Yes
Hold Request Business Object	Used to indicate the business object that you want to use while creating the hold request.	Yes
Detailed Description	Used to specify additional information about the hold request type.	No
Status	Used to indicate the status of the hold request type. The valid values are: <ul style="list-style-type: none"> <li>• Active</li> <li>• Inactive</li> </ul> <div style="border: 1px solid black; padding: 5px; margin-top: 10px;"> <p><b>Note:</b> You cannot change the status of a hold request type to <b>Inactive</b> if there are hold requests which are created using the hold request type and are currently in the <b>Draft</b> or <b>Approval In Progress</b> status.</p> </div>	Yes
Allow Partial Hold for Bill	Used to indicate whether the partial hold amount will be accepted for a bill.	Yes

Field Name	Field Description	Mandatory (Yes or No)
Defer Processing Count	Used to indicate the number of entities to determine if the hold request will be processed in deferred mode.  <b>Note:</b> If the number of entities is less than the <b>Defer Processing Count</b> , the hold request will be processed in real time (i.e. immediately). Defer processing count should be a numerical value without decimal points.	No
Approval Required	Used to indicate whether approval is required while creating the hold request using hold request type.	No
Approval To Do Type	Used to indicate that To Do of the specified To Do type must be created when you submit the hold request for approval.  <b>Note:</b> This field appears only when the <b>Approval Required</b> check box is selected.	Yes (Conditional)  <b>Note:</b> This field is required when the <b>Approval Required</b> check box is selected
Approval To Do Role	Used to indicate that users with the specified To Do role can only approve the hold request submitted for approval.  <b>Note:</b> This field appears only when the <b>Approval Required</b> check box is selected.	Yes (Conditional)  <b>Note:</b> This field is required when the <b>Approval Required</b> check box is selected
Submitter To Do Type	Used to indicate the To Do type for the submitter.	No
Submitter To Do Role	Used to indicate the To Do role for the submitter.	No

**Note:**

**Deferred** mode means in the background when the **Hold Request Periodic Monitor (C1-HLDRQ)** batch is invoked. You can configure the **Hold Request Periodic Monitor (C1-HLDRQ)** batch such that it is executed at regular intervals. When the **Hold Request Periodic Monitor (C1-HLDRQ)** batch is invoked, the system checks whether there are any hold requests in the **Deferred** status. If there is an hold request in the **Deferred** status, then its status is changed to **Active**.

6. Enter the required details.

**Note:** You can search for **To Do Type** by clicking the **Search**  icon corresponding to the respective field.

7. Define processes to hold for the hold request type.

**Note:**

At least one hold process needs to be selected for defining a hold request type.

8. Define characteristics for the hold request type, if required.

9. Click **Save**.

The hold request type is defined.

**Related Topics**

For more information on...	See...
<b>Hold Request Type</b> screen	<a href="#">Hold Request Type</a> on page 1504
<b>Hold Request Type List</b> zone	<a href="#">Hold Request Type List</a> on page 1504
How to define characteristics for a hold request type	<a href="#">Defining Characteristics for a Hold Request Type</a> on page 1510

**Defining Characteristics for a Hold Request Type****Prerequisites**

To define characteristics for a hold request type, you should have:

- Characteristic types defined in the application (where the characteristic entity is set to **Hold Request Type**)

**Procedure**

To define characteristics for a hold request type:

1. Ensure that the **Characteristics** section is expanded when you are defining, editing, or copying a hold request type.

The **Characteristics** section contains the following fields:

Field Name	Field Description	Mandatory (Yes or No)
Characteristic Type	Used to indicate the characteristic type. <b>Note:</b> The list includes only those characteristic types where the characteristic entity is set to <b>Hold Request Type</b> .	Yes (Conditional) <b>Note:</b> This field is required when you are defining a characteristic for the hold request type.
Characteristic Value	Used to specify the value for the characteristic type. <b>Note:</b> On specifying the value for a predefined characteristic type, the description of the characteristic value appears corresponding to the <b>Characteristic Value</b> field.	Yes (Conditional) <b>Note:</b> This field is required when you are defining a characteristic for the hold request type.

2. Enter the required details.

**Note:** If you select a predefined characteristic type, the **Search** () icon appears corresponding to the **Characteristic Value** field. On clicking the **Search** icon, you can search for a predefined characteristic value.

3. If you want to define more than one characteristic for the hold request type, click the **Add** () icon and then repeat step 2.

**Note:** However, if you want to remove a characteristic from the hold request type, click the **Delete** () icon corresponding to the characteristic.

### Related Topics

For more information on...	See...
How to define a hold request type	<a href="#">Defining a Hold Request Type</a> on page 1507
How to edit a hold request type	<a href="#">Editing a Hold Request Type</a> on page 1511
How to copy a hold request type	<a href="#">Copying a Hold Request Type</a> on page 1514

## Editing a Hold Request Type

### Prerequisites

To edit a hold request type, you should have:

- Hold request business objects defined in the application

### Procedure

To edit a hold request type:

1. Click the **Admin** link in the **Application** toolbar.  
A list appears.
2. From the **Admin** menu, select **H** and then click **Hold Request Type**.  
A sub-menu appears.
3. Click the **Search** option from the **Hold Request Type** sub-menu.  
The **Hold Request Type** screen appears.
4. In the **Hold Request Type List** zone, click the **Edit** () icon in the **Edit** column corresponding to the hold request type whose details you want to edit.

The **Hold Request Type** screen appears. It contains the following sections:

- **Main** — Used to specify basic details about the hold request type.
- **Hold Processes** — Used to define the processes to hold for the hold request type.
- **Characteristics** — Used to define characteristics for the hold request type.

The **Main** section contains the following fields:

Field Name	Field Description	Mandatory (Yes or No)
Hold Request Type	Displays the hold request type.	Not applicable
Business Object	Indicates the hold request type business object used while defining the hold request type.	Not applicable

Field Name	Field Description	Mandatory (Yes or No)
Description	Used to specify the description for the hold request type.	Yes
Hold Request Business Object	Used to indicate the business object that you want to use while creating the hold request.	Yes
Detailed Description	Used to specify additional information about the hold request type.	No
Status	Used to indicate the status of the hold request type. The valid values are: <ul style="list-style-type: none"> <li>Active</li> <li>Inactive</li> </ul> <div style="border: 1px solid black; padding: 5px; margin-top: 10px;"> <p><b>Note:</b> You cannot change the status of a hold request type to <b>Inactive</b> if there are hold requests which are created using the hold request type and are currently in the <b>Draft</b> or <b>Approval In Progress</b> status.</p> </div>	Yes
Allow Partial Hold for Bill	Used to indicate whether the partial hold amount will be accepted for a bill.	Yes
Defer Processing Count	Used to indicate the number of entities to determine if the hold request will be processed in deferred mode. <div style="border: 1px solid black; padding: 5px; margin-top: 10px;"> <p><b>Note:</b> If the number of entities is less than the <b>Defer Processing Count</b>, the hold request will be processed in real time (i.e. immediately). Defer processing count should be a numerical value without decimal points.</p> </div>	No
Approval Required	Used to indicate whether approval is required while creating the hold request using hold request type.	No
Approval To Do Type	Used to indicate that To Do of the specified To Do type must be created when you submit the hold request for approval. <div style="border: 1px solid black; padding: 5px; margin-top: 10px;"> <p><b>Note:</b> This field appears only when the <b>Approval Required</b> check box is selected.</p> </div>	Yes (Conditional) <div style="border: 1px solid black; padding: 5px; margin-top: 10px;"> <p><b>Note:</b> This field is required when the <b>Approval Required</b> check box is selected</p> </div>



Field Name	Field Description	Mandatory (Yes or No)
Approval To Do Role	Used to indicate that users with the specified To Do role can only approve the hold request submitted for approval.  <b>Note:</b> This field appears only when the <b>Approval Required</b> check box is selected.	Yes (Conditional)  <b>Note:</b> This field is required when the <b>Approval Required</b> check box is selected
Submitter To Do Type	Used to indicate the To Do type for the submitter.	No
Submitter To Do Role	Used to indicate the To Do role for the submitter.	No

**Note:**  
**Deferred** mode means in the background when the **Hold Request Periodic Monitor (C1-HLDRQ)** batch is invoked. You can configure the **Hold Request Periodic Monitor (C1-HLDRQ)** batch such that it is executed at regular intervals. When the **Hold Request Periodic Monitor (C1-HLDRQ)** batch is invoked, the system checks whether there are any hold requests in the **Deferred** status. If there is an hold request in the **Deferred** status, then its status is changed to **Active**.

**Tip:** Alternatively, you can click the **Edit** button in the **Hold Request Type** zone to edit the details of the hold request type.

5. Modify the details, if required.
6. Define, edit, or remove characteristics from the hold request type, if required.
7. Click **Save**.

The changes made to the hold request type are saved.

### **Related Topics**

For more information on...	See...
<b>Hold Request Type</b> screen	<a href="#">Hold Request Type</a> on page 1504
<b>Hold Request Type List</b> zone	<a href="#">Hold Request Type List</a> on page 1504
<b>Hold Request Type</b> zone	<a href="#">Hold Request Type</a> on page 1505
How to define characteristics for a hold request type	<a href="#">Defining Characteristics for a Hold Request Type</a> on page 1510

## **Deleting a Hold Request Type**

### **Procedure**

To delete a hold request type:

1. Click the **Admin** link in the **Application** toolbar.  
A list appears.
2. From the **Admin** menu, select **H** and then click **Hold Request Type**.

A sub-menu appears.

3. Click the **Search** option from the **Hold Request Type** sub-menu.

The **Hold Request Type** screen appears.

4. In the **Hold Request Type List** zone, click the **Delete** () icon in the **Delete** column corresponding to the hold request type that you want to delete.

A message appears confirming whether you want to delete the hold request type.

**Note:** You can delete a hold request type only when you have not defined a hold request using the hold request type.

**Tip:** Alternatively, you can click the **Delete** button in the **Hold Request Type** zone to delete the hold request type.

5. Click **OK**.

The hold request type is deleted.

### **Related Topics**

<b>For more information on...</b>	<b>See...</b>
<b>Hold Request Type</b> screen	<a href="#">Hold Request Type</a> on page 1504
<b>Hold Request Type List</b> zone	<a href="#">Hold Request Type List</a> on page 1504
<b>Hold Request Type</b> zone	<a href="#">Hold Request Type</a> on page 1505

## **Copying a Hold Request Type**

Instead of creating a hold request type from scratch, you can create a new hold request type using an existing hold request type. This is possible through copying a hold request type. On copying a hold request type, the details including the characteristics are copied to the new hold request type. You can then edit the details, if required.

### **Prerequisites**

To copy a hold request type, you should have:

- Hold request type (whose copy you want to create) defined in the application
- Hold request business objects defined in the application

### **Procedure**

To copy a hold request type:

1. Click the **Admin** link in the **Application** toolbar.

A list appears.

2. From the **Admin** menu, select **H** and then click **Hold Request Type**.

A sub-menu appears.

3. Click the **Search** option from the **Hold Request Type** sub-menu.

The **Hold Request Type** screen appears.

4. In the **Hold Request Type List** zone, click the **Duplicate** () icon in the **Duplicate** column corresponding to the hold request type whose copy you want to create.

The **Hold Request Type** screen appears. It contains the following sections:

- **Main** — Used to specify basic details about the hold request type.
- **Hold Processes** — Used to define the processes to hold for the hold request type.
- **Characteristics** — Used to define characteristics for the hold request type.

The **Main** section contains the following fields:

Field Name	Field Description	Mandatory (Yes or No)
Hold Request Type	Used to specify the hold request type.	Yes
Business Object	Indicates the hold request type business object used while defining the hold request type.	Not applicable
Description	Used to specify the description for the hold request type.	Yes
Hold Request Business Object	Used to indicate the business object that you want to use while creating the hold request.	Yes
Detailed Description	Used to specify additional information about the hold request type.	No
Status	Used to indicate the status of the hold request type. The valid values are: <ul style="list-style-type: none"> <li>• Active</li> <li>• Inactive</li> </ul> <div style="border: 1px solid black; padding: 5px; margin-top: 10px;"> <p><b>Note:</b> You cannot change the status of a hold request type to <b>Inactive</b> if there are hold requests which are created using the hold request type and are currently in the <b>Draft</b> or <b>Approval In Progress</b> status.</p> </div>	Yes
Allow Partial Hold for Bill	Used to indicate whether the partial hold amount will be accepted for a bill.	Yes

Field Name	Field Description	Mandatory (Yes or No)
Defer Processing Count	<p>used to indicate the number of bills to determine if the hold request will be processed in deferred mode.</p> <p><b>Note:</b> Deferred mode means in the background when the <b>Hold Request Periodic Monitor (C1-HLDRQ)</b> batch is invoked. You can configure the <b>Hold Request Periodic Monitor (C1-HLDRQ)</b> batch such that it is executed at regular intervals. When the <b>Hold Request Periodic Monitor (C1-HLDRQ)</b> batch is invoked, the system checks whether there are any hold requests in the <b>Deferred</b> status. If there is an hold request in the <b>Deferred</b> status, then its status is changed to <b>Active</b>.</p> <p>If the number of bills is less than the Defer Processing Count, the hold request will be processed in real time (i.e. immediately).</p> <p>Defer processing count should be a numerical value without decimal points.</p>	No
Approval Required	Used to indicate whether approval is required while creating the hold request using hold request type.	No
Approval To Do Type	<p>Used to indicate that To Do of the specified To Do type must be created when you submit the hold request for approval.</p> <p><b>Note:</b> This field appears only when the <b>Approval Required</b> check box is selected.</p>	<p>Yes (Conditional)</p> <p><b>Note:</b> This field is required when the <b>Approval Required</b> check box is selected</p>
Approval To Do Role	<p>Used to indicate that users with the specified To Do role can only approve the hold request submitted for approval.</p> <p><b>Note:</b> This field appears only when the <b>Approval Required</b> check box is selected.</p>	<p>Yes (Conditional)</p> <p><b>Note:</b> This field is required when the <b>Approval Required</b> check box is selected</p>
Submitter To Do Type	Used to indicate the To Do type for the submitter.	No
Submitter To Do Role	Used to indicate the To Do role for the submitter.	No

**Tip:** Alternatively, you can click the **Duplicate** button in the **Hold Request Type** zone to create a copy of the hold request type.

5. Enter the required details.
6. Define, edit or remove processes from the hold request type, if required.
7. Define, edit, or remove characteristics from the hold request type, if required.
8. Click **Save**.

The new hold request type is defined.

### **Related Topics**

<b>For more information on...</b>	<b>See...</b>
<b>Hold Request Type</b> screen	<a href="#">Hold Request Type</a> on page 1504
<b>Hold Request Type List</b> zone	<a href="#">Hold Request Type List</a> on page 1504
<b>Hold Request Type</b> zone	<a href="#">Hold Request Type</a> on page 1505
How to define characteristics for a hold request type	<a href="#">Defining Characteristics for a Hold Request Type</a> on page 1510

## **Viewing the Hold Request Type Details**

### **Procedure**

To view the details of a hold request type:

1. Click the **Admin** link in the **Application** toolbar.  
A list appears.
2. From the **Admin** menu, select **H** and then click **Hold Request Type**.  
A sub-menu appears.
3. Click the **Search** option from the **Hold Request Type** sub-menu.  
The **Hold Request Type** screen appears.
4. In the **Hold Request Type List** zone, click the **Broadcast**  icon corresponding to the hold request type whose details you want to view.  
The **Hold Request Type** zone appears.
5. View the details of the hold request type in the **Hold Request Type** zone.

### **Related Topics**

<b>For more information on...</b>	<b>See...</b>
<b>Hold Request Type</b> screen	<a href="#">Hold Request Type</a> on page 1504
<b>Hold Request Type List</b> zone	<a href="#">Hold Request Type List</a> on page 1504
<b>Hold Request Type</b> zone	<a href="#">Hold Request Type</a> on page 1505

## Hold Request (Used for Searching)

The **Hold Request** screen allows you to search for a hold request using various search criteria. It also allows you to create a hold request. Through this screen, you can navigate to the following screen:

- [Hold Request \(Used for Viewing\)](#) on page 1528

This screen consists of the following zone:

- [Search Hold Request](#) on page 1518



## Search Hold Request

The **Search Hold Request** zone allows you to search for hold requests using various search criteria. This zone contains the following two sections:

- **Search Criteria** — The **Search Criteria** section contains the following fields:

Field Name	Field Description	Mandatory (Yes or No)
Search By	Used to indicate whether you want to search for a hold request using request or bill details. The valid values are: <ul style="list-style-type: none"> <li>• Request Details</li> <li>• Bill Details</li> </ul> <div style="border: 1px solid black; padding: 2px; margin-top: 5px;"><b>Note:</b> By default, the <b>Request Details</b> option is selected.</div>	Yes
Hold Request Type	Used to search hold requests which are created using a particular hold request type. <div style="border: 1px solid black; padding: 2px; margin-top: 5px;"><b>Note:</b> This field appears only when you select the <b>Request Details</b> option from the <b>Search By</b> list.</div>	No
Hold Process	Used to search hold requests which are created using a particular hold process. <div style="border: 1px solid black; padding: 2px; margin-top: 5px;"><b>Note:</b> This field appears only when you select the <b>Request Details</b> option from the <b>Search By</b> list.</div>	No
Status	Used to search hold requests with a particular status. The valid values are: <ul style="list-style-type: none"> <li>• Active</li> <li>• Draft</li> <li>• Released</li> <li>• Approval In Progress</li> <li>• Deferred Processing</li> <li>• Rejected</li> </ul> <div style="border: 1px solid black; padding: 2px; margin-top: 5px;"><b>Note:</b> This field appears only when you select the <b>Request Details</b> option from the <b>Search By</b> list.</div>	No

Field Name	Field Description	Mandatory (Yes or No)
Account ID	<p>Used to search hold requests which are created for a particular account.</p> <div style="border: 1px solid black; padding: 5px;"> <p><b>Note:</b> This field appears only when you select the <b>Request Details</b> option from the <b>Search By</b> list. You can search for an account by clicking the <b>Search</b>  icon corresponding to the field.</p> </div>	No
Entity	<p>Used to search hold request with a particular entity. The valid values are:</p> <ul style="list-style-type: none"> <li>• Account</li> <li>• Person</li> <li>• Bill</li> </ul> <div style="border: 1px solid black; padding: 5px;"> <p><b>Note:</b> This field appears only when you select the <b>Request Details</b> option from the <b>Search By</b> list.</p> </div>	No
User ID	<p>Used to search hold requests which are created by a particular user.</p> <div style="border: 1px solid black; padding: 5px;"> <p><b>Note:</b> This field appears only when you select the <b>Request Details</b> option from the <b>Search By</b> list.</p> </div>	
Start Date	<p>Used to search hold requests which are created from a particular date onwards.</p> <div style="border: 1px solid black; padding: 5px;"> <p><b>Note:</b> This field appears only when you select the <b>Request Details</b> option from the <b>Search By</b> list.</p> </div>	No
End Date	<p>Used to search hold requests which are created till a particular date.</p> <div style="border: 1px solid black; padding: 5px;"> <p><b>Note:</b> This field appears only when you select the <b>Request Details</b> option from the <b>Search By</b> list.</p> </div>	No
Hold Request ID	<p>Used to search a particular hold request.</p> <div style="border: 1px solid black; padding: 5px;"> <p><b>Note:</b> This field appears only when you select the <b>Request Details</b> option from the <b>Search By</b> list.</p> </div>	No

Field Name	Field Description	Mandatory (Yes or No)
Person ID	Used to search hold requests which are created for a particular person.  <b>Note:</b> This field appears only when you select the <b>Request Details</b> option from the <b>Search By</b> list. You can search for a person by clicking the <b>Search</b>  icon corresponding to the field.	No
Bill ID	Used to search hold requests which includes bill segments or adjustments of a particular bill.  <b>Note:</b> This field appears only when you select the <b>Bill Details</b> option from the <b>Search By</b> list. You can search for a bill by clicking the <b>Search</b>  icon corresponding to the field.	No
Bill Date From	Used to search hold requests which includes bill segments or adjustments of bills which are created from a particular date onwards.  <b>Note:</b> This field appears only when you select the <b>Bill Details</b> option from the <b>Search By</b> list.	No
To	Used to search hold requests which includes bill segments or adjustments of bills which are created till a particular date.  <b>Note:</b> This field appears only when you select the <b>Bill Details</b> option from the <b>Search By</b> list.	No

**Note:** You must specify at least one search criterion while searching for a hold request.

- **Search Results** — On clicking the **Search** button, the search results appear based on the specified search criteria. The **Search Results** section contains the following columns:

Column Name	Column Description
Create Date/Time	Displays the date and time when the hold request is created.
Hold Request Information	Displays information about the hold request.  <b>Note:</b> It has a link. On clicking the link, the <b>Hold Request</b> screen appears where you can view the details of the respective hold request.



Column Name	Column Description
Status	Indicates the status of the hold request. The valid values are: <ul style="list-style-type: none"> <li>• Active</li> <li>• Draft</li> <li>• Released</li> </ul>
Start Date	Displays the date when the hold request is created.
End Date	Displays the date when the hold request is released.
Hold Processes	Displays the hold processes using which hold request is created.
Hold Reason	Displays the hold reason for the hold request.
Created By	Indicates the user who has created the hold request.

### **Related Topics**

For more information on...	See...
How to search for a hold request	<a href="#">Searching for a Hold Request</a> on page 1521
How to view the details of a hold request	<a href="#">Viewing the Hold Request Details</a> on page 1527
How to create a hold request	<a href="#">Creating a Hold Request</a> on page 1522

## **Searching for a Hold Request**

### **Prerequisites**

To search for a hold request, you should have:

- Hold request types defined in the application

### **Procedure**

To search for a hold request:

1. Click the **Menu** link in the **Application** toolbar.  
A list appears.
2. From the **Main** menu, select **Financial** and then click **Hold Request**.  
A sub-menu appears.
3. Click the **Search** option from the **Hold Request** sub-menu.  
The **Hold Request** screen appears.
4. Enter the search criteria in the **Search Hold Request** zone.

**Note:** ORMB search engine supports wildcard search, where you can substitute the percentage (%) symbol as a stand in for any word or letter in a search criteria. You can use the ‘%’ wildcard character in all input fields except the date and ID fields. The ‘%’ wildcard character is suffixed automatically at the end of the partial search criteria. Therefore, you may or may not specify the wildcard character at the end of the partial search criteria. However, you have to prefix the wildcard character manually wherever required.

5. Click **Search**.

A list of hold requests that meet the search criteria appears in the **Search Results** section.

### **Related Topics**

<b>For more information on...</b>	<b>See...</b>
<b>Hold Request</b> screen	<a href="#">Hold Request (Used for Searching)</a> on page 1518
<b>Search Hold Request</b> zone	<a href="#">Search Hold Request</a> on page 1518

## Creating a Hold Request

### Prerequisites

To create a hold request, you should have:

- Hold request types defined in the application.

### Procedure

To create a hold request:

1. Do either of the following:

<b>If you want to...</b>	<b>Then...</b>
Define a hold request from the <b>Account Receivable Central</b> screen	<ol style="list-style-type: none"> <li>1. Click the <b>Menu</b> link in the <b>Application</b> toolbar. A list appears.</li> <li>2. From the <b>Main</b> menu, select <b>Financial</b> and then click <b>Account Receivable Central</b>.  The <b>Account Receivable Central</b> screen appears.</li> <li>3. Search for the bill in the <b>Account Receivable Central</b> screen.</li> <li>4. In the <b>Search Results</b> section, select the required bill and then click <b>Hold</b>.</li> </ol> <div style="border: 1px solid black; padding: 5px; margin-top: 10px;"> <p><b>Note:</b> Bills are selected to be on hold from <b>Account Receivable Central</b>. Only one bill at a time is allowed to select for <b>Hold Request</b> from <b>Account Receivable Central</b></p> </div>
Define a hold request from the <b>Delinquency Central</b> screen	<ol style="list-style-type: none"> <li>1. Click the <b>Menu</b> link in the <b>Application</b> toolbar. A list appears.</li> <li>2. From the <b>Main</b> menu, select <b>Credit &amp; Collection</b> and then click <b>Delinquency Central</b>.  The <b>Delinquency Central</b> screen appears.</li> <li>3. Search for the overdue process in the <b>Delinquency Central</b> screen.</li> </ol>

If you want to...	Then...
	<p><b>4.</b> In the <b>Search Results</b> section, select the required overdue process and then click <b>Create Hold Request</b>.</p> <div style="border: 1px solid black; padding: 5px; background-color: #f0f0f0;"> <p><b>Note:</b> Accounts are selected to be on hold from <b>Delinquency Central</b> screen Only one account at a time is allowed to select for <b>Hold Request</b> from <b>Delinquency Central</b> screen.</p> </div>
Define a hold request from the <b>Hold Request</b> screen	<ol style="list-style-type: none"> <li><b>1.</b> Click the <b>Menu</b> link in the <b>Application</b> toolbar. A list appears.</li> <li><b>2.</b> From the <b>Main</b> menu, select <b>Financial</b> and then click <b>Hold Request</b>. A sub-menu appears.</li> <li><b>3.</b> Click the <b>Add</b> option from the <b>Hold Request</b> sub-menu.</li> </ol>

The **Add Hold Request** screen appears. It contains the following fields:

Field Name	Field Description	Mandatory (Yes or No)
Hold Request Type	Used to indicate the request type using which you want to create the hold request.	Yes

**Tip:** Alternatively, you can access the **Add Hold Request** screen by clicking the **Add** button in the **Page Title** area of the **Hold Request** screen.

- 2.** Select the required hold request type from the respective fields.
- 3.** Click **OK**.

The hold request is defined and the status of the hold request is set to **Draft**. The **Hold Request** screen appears where you can view the details of the hold request. It contains the following sections:

- **Main** – Used to specify basic details about the hold request. This section contains the following fields:

Field Name	Field Description	Mandatory (Yes or No)
Hold Request Type	Indicates the hold request type using which you want to create the hold request.	Not applicable

Field Name	Field Description	Mandatory (Yes or No)
Start Date	Used to specify the date from when the hold request is effective.  <b>Note:</b> The hold request start date cannot be later than the hold request end date. By default, system date appears in this field.	Yes
End Date	Used to specify the date till when the hold request is effective.  <b>Note:</b> The hold request end date cannot be earlier than the hold request start date.	Yes
Hold Reason	Used to indicate the reason why you want to hold the entity.  <b>Note:</b> The hold reason must exist in the <b>HOLD_REASON_FLG</b> lookup field and its status must be <b>Active</b> .	Yes
Entity	Used to indicate the type of the entity for which you want to create the hold request. The valid values are: <ul style="list-style-type: none"> <li>• Account</li> <li>• Bill</li> <li>• Person</li> </ul> <b>Note:</b> If bill is kept on hold using <b>Account Receivable Central</b> screen, then this field will display <b>Bill</b> as an entity and <b>Hold Entities</b> section will display information about this bill.	Yes
Comments	Used to specify the additional information about hold request.	No

- **Hold Entities** — Used to specify details of the selected hold entity. This section contains the following fields:

Field Name	Field Description	Mandatory (Yes or No)
Hold Entity ID	<p>Used to specify the hold entity ID.</p> <p><b>Note:</b>            You can search for an entity ID by clicking the <b>search</b>  icon corresponding to the field</p> <p>If the hold entity is account, you must specify the account ID in this field. If the hold entity is person, you must specify the person ID in this field. And, if the hold entity is bill, you must specify the bill ID in this field.</p>	Yes
Start Date	<p>Used to specify the date from when you want to hold the entity.</p> <p><b>Note:</b>            By default, system date appears in this field</p> <p>The hold entity start date must be between the hold request start and end dates and between at least one process's start and end dates.</p> <p>The hold entity start date cannot be later than the hold entity end date.</p>	Yes
End Date	<p>Used to specify the date till when you want to hold the entity.</p> <p><b>Note:</b>            The hold entity end date must be between hold request start and end dates and between the process's start and end dates.</p> <p>The hold entity end date cannot be earlier than the hold entity start date.</p>	No
Hold Amount	<p>Displays the amount which is kept on hold.</p> <p><b>Note:</b> This column appears only when the hold entity is <b>Bill</b>.</p>	Not applicable

- **Hold Processes** — Used to indicate the processes to be on hold for the hold request. By default, processes are defined on the hold request type. It contains the following fields:

Field Name	Field Description	Mandatory (Yes or No)
Hold Process	Used to indicate the process that needs to be kept on hold.	Yes
Start Date	Used to specify the date from when process is to be on hold for the hold request.  <div style="border: 1px solid black; padding: 5px;"> <p><b>Note:</b> By default, system date appears in this field The hold process start date must be between the hold request start and end dates.</p> </div>	Yes
End Date	Used to specify the date till when the process is to be on hold.	No

- **Characteristics** — Used to define the characteristics for the hold request. This section contains the following fields:

Field Name	Field Description	Mandatory (Yes or No)
Effective Date	Used to specify the date from when the characteristic is effective for the hold request.	Yes (Conditional)  <div style="border: 1px solid black; padding: 5px;"> <p><b>Note:</b> This field is required when you are defining a characteristic for the hold request.</p> </div>
Characteristic Type	Used to indicate the characteristic type.  <div style="border: 1px solid black; padding: 5px;"> <p><b>Note:</b> The list includes only those characteristic types where the characteristic entity is set to <b>Hold Request</b>.</p> </div>	Yes (Conditional)  <div style="border: 1px solid black; padding: 5px;"> <p><b>Note:</b> This field is required when you are defining a characteristic for the hold request.</p> </div>
Characteristic Value	Used to specify the value for the characteristic type.  <div style="border: 1px solid black; padding: 5px;"> <p><b>Note:</b> On specifying the value for a predefined characteristic type, the description of the characteristic value appears corresponding to the <b>Characteristic Value</b> field.</p> </div>	Yes (Conditional)  <div style="border: 1px solid black; padding: 5px;"> <p><b>Note:</b> This field is required when you are defining a characteristic for the hold request.</p> </div>

#### 4. Enter the required details

<p><b>Note:</b> Processes and Entities start dates and end dates are expected to be within the limit of Hold Request Start Date and End date.</p> <p>You can search for a hold entity by clicking the <b>search</b>  icon corresponding to the respective field.</p>
---

5. Add entities and processes for the hold request.
6. Define characteristics for the hold request, if required.
7. Click **Save**.

The hold request is created and the status of the hold request is set to **Draft**. The **Hold Request** screen appears with the details of hold request.

**Note:** It is recommended that user should set the **C1-HLMON** batch every time the hold request is generated. Otherwise, alert would be shown in the dashboard which may not give the proper representation of active hold requests.

### Related Topics

For more information on...	See...
<b>Hold Request</b> screen	<a href="#">Hold Request (Used for Searching)</a> on page 1518
How to edit a hold request	<a href="#">Editing a Hold Request</a> on page 1543
How to define characteristics for a hold request	<a href="#">Defining Characteristics for a Hold Request</a> on page 1542

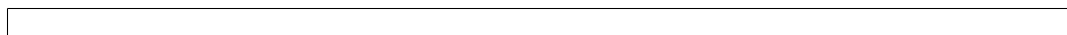

## Viewing the Hold Request Details

### Procedure

To view the details of a hold request:

1. Search for the hold request in the **Hold Request** screen.
2. In the **Search Results** section, click the link in the **Hold Request Information** column corresponding to the hold request whose details you want to view.

The **Hold Request** screen appears. It consists of the following tabs:

- **Main** – Displays information about the hold request. It contains the following zones:
  - **Hold Request** – Displays the details of the hold request.
  - **Hold Entities** – Lists the entities, such as person, accounts, or bills that are on hold request.
  - **Search Account** — Searches the accounts to be put on hold.

**Note:** This zone appears only when hold request is for **Account** and its status is **Draft**.

- **Search Bill** — Searches the bills to be put on hold.

**Note:** This zone appears only when hold request is for **Bill** and its status is **Draft**.

- **Search Person** — Searches the persons to be put on hold.

**Note:** This zone appears only when hold request is for **Person** and its status is **Draft**.

- **Log** – Lists the complete trail of actions performed on the hold request.
3. View the details of the hold request in the **Hold Request** zone.
  4. View the hold request entities (such as person, accounts, or bills) in the **Hold Entities** zone.

### Related Topics

For more information on...	See...
<b>Hold Request</b> screen	<a href="#">Hold Request (Used for Searching)</a> on page 1518
<b>Hold Request</b> zone	<a href="#">Hold Request</a> on page 1529
How to search for a hold request	<a href="#">Searching for a Hold Request</a> on page 1521

## Hold Request (Used for Viewing)

Once you create a hold request, the **Hold Request** screen allows you to:

- Add entities in a hold request
- Add processes in a hold request
- Edit the details of a hold request
- Edit the hold amount against each entity. This is valid for only bill.
- Delete a hold request
- View the details of a hold request
- Submit a hold request for approval
- Approve or reject a hold request
- Resubmit a hold request for approval
- Activate and Release a hold request
- View the log of a hold request
- Add a log entry for a hold request

This screen consists of the following tabs:

- **Main** – Displays information about the hold request. It contains the following zones:
  - **Hold Request** – Displays the details of the hold request.
  - **Hold Entities** – Lists the entities, such as person, accounts, or bills that are on hold request.
  - **Search Account** — Searches the accounts to be put on hold.

**Note:** This zone appears only when hold request is for **Account** and its status is **Draft**.

- **Search Bill** — Searches the bills to be put on hold.

**Note:** This zone appears only when hold request is for **Bill** and its status is **Draft**.

- **Search Person** — Searches the persons to be put on hold.

**Note:** This zone appears only when hold request is for **Person** and its status is **Draft**.

- **Log** — Lists complete trail of actions performed on the hold request. This tab contains the following zone:
  - **Hold Request Log** — Displays the actions performed on the hold request.

### Hold Request - Main

The **Main** tab on the **Hold Request** contains the following zones:



- [Hold Request](#) on page 1529
- [Hold Entities](#) on page 1531
- [Search Account](#) on page 1532

**Note:** This zone appears only when hold request is for **Account** and its status is **Draft** .

- [Search Bill](#) on page 1535

**Note:** This zone appears only when hold request is for **Bill** and its status is **Draft** .

- [Search Person](#) on page 1536

**Note:** This zone appears only when hold request is for **Person** and its status is **Draft** .

## Hold Request

The **Hold Request** zone displays the details of the hold request. This zone contains the following sections:

- **Main** — This section provides basic information about the hold request. It contains the following fields:

Field Name	Field Description
Hold Request Information	Displays information about the hold request.
Hold Request Type	Indicates the hold request type using which the hold request is created. <b>Note:</b> It has a link. On clicking the link, the <b>Hold Request Type</b> screen appears where you can view the details of the hold request type.
Status	Indicates the status of the hold request.
Status Reason	Indicates the reason why the hold request is released. <b>Note:</b> This field appears only when the hold request is in the <b>Released</b> status. It has a link. On clicking the link, the <b>Status Reason</b> screen appears where you can view the details of the released reason.
Start Date	Displays the date when the hold request is created.
End Date	Displays the date when the hold request is released.
Hold Reason	Displays the reason of hold request.
Entity	Displays the hold request entity.
Comments	Displays the additional information for a hold request.

- **Hold Processes** — Lists the processes that are on hold in the hold request. It contains the following columns:

Column Name	Column Description
Hold Process	Lists the processes that are on hold.
Start Date	Displays the date from when the process is to be on hold for hold request.
End Date	Displays the date till when the process is to be on hold for hold request.

- **Characteristics** — Lists the characteristics defined for the hold request. It contains the following fields:

Field Name	Field Description
Effective Date	Displays the date from when hold request is effective.
Characteristic Type	Indicates the characteristic type.
Characteristic Value	Displays the value of the characteristic type.

- **Record Actions** — This section contains the following buttons:

Button Name	Button Description
Edit	Used to edit the details of the hold request. <b>Note:</b> The <b>Edit</b> button appears only when the hold request is in the <b>Draft</b> or <b>Active</b> status.
Delete	Used to delete the hold request. <b>Note:</b> The <b>Delete</b> button appears only when the hold request is in the <b>Draft</b> status.
Submit	Used to activate the hold request. <b>Note:</b> The <b>Submit</b> button appears only when the hold request is in the <b>Draft</b> status.
Re Submit	Used to re-submit the hold request. <b>Note:</b> the <b>Re Submit</b> button appears only when the hold request is in the <b>Approval In Progress</b> status.
Approve	Used to approve the hold request. <b>Note:</b> the <b>Approve</b> button appears only when the hold request is in the <b>Approval In Progress</b> status.
Reject	Used to reject the hold request. <b>Note:</b> the <b>Reject</b> button appears only when the hold request is in the <b>Approval In Progress</b> status.
Release	Used to release the hold request. <b>Note:</b> The <b>Release</b> button appears only when the hold request is in the <b>Active</b> status.

- **Record Information** — This section contains the following fields:

Field Name	Field Description
Business Object	Indicates the business object using which the hold request is created. In addition, a context menu appears corresponding to this field which helps in navigating to other screens in the application. <b>Note:</b> It has a link. On clicking the link, the <b>Business Object</b> screen appears where you can view the details of the respective business object.

Field Name	Field Description
Status Date/Time	Displays the date and time when the hold request status is updated.
Create Date/Time	Displays the date and time when the hold request is created.

### Hold Entities

The **Hold Entities** zone on the **Hold Request** screen lists the entities that are on hold request. This zone contains the following columns:

Column Name	Column Description
Person Information	<p>Displays information about the person. In addition, this column has a context menu which helps in navigating to other screens in the application.</p> <p><b>Note:</b> It has a link. On clicking the link, the <b>Person</b> screen appears with details of the respective person.</p>
Account Information	<p>Displays information about the account. In addition, this column has a context menu which helps in navigating to other screens in the application.</p> <p><b>Note:</b> It has a link. On clicking the link, the <b>Account</b> screen appears with details of the respective account.</p>
Bill Information	<p>Displays information about the bill. In addition, this column has a context menu which helps in navigating to other screens in the application.</p> <p><b>Note:</b> It has a link. On clicking the link, the <b>Bill</b> screen appears with details of the respective bill.</p>
Start Date	Displays the date from when the entity is on hold.
End Date	<p>Displays the date till when the entity is on hold.</p> <p><b>Note:</b> When hold request for entity is released, then its end date gets updated to the release date only when its end date lies between the hold request start date and end date .</p>
Hold Amount	<p>Displays the amount on hold.</p> <p><b>Note:</b> This column appears only when the entity bill is on hold.</p>
Bill After Date	<p>Displays the date after which bills can be generated.</p> <p><b>Note:</b> This column appears only when the entity account is on hold.</p>
Postpone Credit Review Until	<p>Displays the date till when overdue process is to be on hold.</p> <p><b>Note:</b> This column appears only when the entity account is on hold.</p>
Defer Auto Pay Date	<p>Displays the date from when auto pay process is to be put on deferred mode.</p> <p><b>Note:</b> This column appears only when the entity account is on hold.</p>

**Note:**

You can directly edit the start and end date of the hold entities by selecting the corresponding column and then click the **Edit** button available on the upper left corner of the **Hold Entities** zone.

You can directly delete the hold entities by selecting the corresponding column and then click the **Delete** button available on the upper left corner of the **Hold Entities** zone.

**Related Topics**

For more information on...	See...
How to view the log of an hold request	<a href="#">Viewing the Log of a Hold Request</a> on page 1553
Search Account	<a href="#">Search Account</a> on page 1532
Search Bill	<a href="#">Search Bill</a> on page 1535
Search Person	<a href="#">Search Person</a> on page 1536

**Search Account**

The **Search Account** zone searches for accounts to add in a hold request. This zone contains the following sections:

- **Search Criteria** — This section contains the following fields:

Field Name	Field Description	Mandatory (Yes or No)
Search By	<p>Used to indicate whether you want to search for accounts using account or policy details.</p> <p>The valid values are:</p> <ul style="list-style-type: none"> <li>• Account Details</li> <li>• Policy Details</li> </ul> <p><b>Note:</b> By default, the <b>Account Details</b> option is selected.</p>	Yes
Account ID	<p>Used to search for a particular account.</p> <p><b>Note:</b> This field appears only when you select the <b>Account Details</b> option from the <b>Search By</b> list. You can search for an account by clicking the <b>Search</b>  icon corresponding to the field.</p>	No
Address Source	<p>Used to indicate the source of address. The valid values are:</p> <ul style="list-style-type: none"> <li>• Account Override</li> <li>• Mailing Location on Account</li> <li>• Person</li> </ul> <p><b>Note:</b> This field appears only when you select the <b>Account Details</b> option from the <b>Search By</b> list.</p>	No

Field Name	Field Description	Mandatory (Yes or No)
Division	Used to search for accounts which belong to a particular division.  <b>Note:</b> This field appears only when you select the <b>Account Details</b> option from the <b>Search By</b> list.	No
Customer Class	Used to indicate the customer class to which the account belongs.  <b>Note:</b> This field appears only when you select the <b>Account Details</b> option from the <b>Search By</b> list.	No
Bill Cycle	Used to indicate the bill cycle of the account.  <b>Note:</b> This field appears only when you select the <b>Account Details</b> option from the <b>Search By</b> list.	No
Price Item	Used to search a particular price item.  <b>Note:</b> This field appears only when you select the <b>Policy Details</b> option from the <b>Search By</b> list. You can search for a price item by clicking the <b>Search</b>  icon corresponding to the field.	No
Policy Plan Number	Used to indicate the plan number of the policy.  <b>Note:</b> This field appears only when you select the <b>Policy Details</b> option from the <b>Search By</b> list.	No
Policy Type	Used to indicate the type of policy.  <b>Note:</b> This field appears only when you select the <b>Policy Details</b> option from the <b>Search By</b> list.	No
Source System	Used to indicate the name of the external system from where the policy originated.  <b>Note:</b> This field appears only when you select the <b>Policy Details</b> option from the <b>Search By</b> list.	No
Policy Number	Used to indicate the policy number.  <b>Note:</b> This field appears only when you select the <b>Policy Details</b> option from the <b>Search By</b> list.	No

Field Name	Field Description	Mandatory (Yes or No)
Status	Used to indicate the status of the policy. The valid values are: <ul style="list-style-type: none"> <li>• Pending</li> <li>• In Force/ Active</li> <li>• Pending Cancellation</li> <li>• Pending Resinstatement</li> <li>• Pending Termination</li> <li>• Reinstate</li> <li>• Terminated</li> <li>• Cancelled</li> </ul> <div style="border: 1px solid black; padding: 2px;"><b>Note:</b> This field appears only when you select the <b>Policy Details</b> option from the <b>Search By</b> list.</div>	No
Policy Start Date	Used to indicate the date from when the policy is effective. <div style="border: 1px solid black; padding: 2px;"><b>Note:</b> This field appears only when you select the <b>Policy Details</b> option from the <b>Search By</b> list.</div>	No
Policy End Date	Used to indicate the date till when the policy is effective. <div style="border: 1px solid black; padding: 2px;"><b>Note:</b> This field appears only when you select the <b>Policy Details</b> option from the <b>Search By</b> list.</div>	No
Characteristic Type/Value	Used to indicate the characteristic Type/ Value associated with the policy. <div style="border: 1px solid black; padding: 2px;"><b>Note:</b> This field appears only when you select the <b>Policy Details</b> option from the <b>Search By</b> list.</div>	No
State	Used to indicate the state name.	No
County	Used to indicate the county name.	No
Postal	Used to indicate the postal or zip code.	No

**Note:**

You must specify at least one search criterion while searching for accounts.

ORMB search engine supports wildcard search, where you can substitute the percentage (%) symbol as a stand in for any word or letter in a search criteria. You can use the ‘%’ wildcard character in all input fields except the date and ID fields. The ‘%’ wildcard character is suffixed automatically at the end of the partial search criteria. Therefore, you may or may not specify the wildcard character at the end of the partial search criteria. However, you have to prefix the wildcard character manually wherever required.

- **Search Results** — On clicking the **Search** button, the search results appear based on the specified search criteria. The **Search Results** section contains the following columns:

Column Name	Column Description
Account Information	Displays the account information.
Country	Displays the country name.
State	Displays the state name.
County	Displays the county name.
Postal	Displays the postal or zip code.
Customer Class	Displays the customer class of the account.
Division	Displays the division to which the account belongs.
Entity ID	Displays the entity ID.

### Related Topics

For more information on...	See...
How to search Accounts	<a href="#">Searching Accounts</a> on page 1539
How to view the log of a hold request	<a href="#">Viewing the Log of a Hold Request</a> on page 1553

### Search Bill

The **Search Bill** zone searches for bills to add in a hold request. This zone contains the following sections:

- **Search Criteria** — This section contains the following fields:

Field Name	Field Description	Mandatory (Yes or No)
Search By	Displays the value as Bill Details.	Not applicable
Bill ID	Used to search a particular bill.  <b>Note:</b> You can search for a bill by clicking the <b>Search</b>  icon corresponding to the field.	No
Alternate Bill ID	Used to search a particular bill using the alternate bill ID.	No
Show All Bills	Used to search all the bills having non-zero as well as zero amount.  <b>Note:</b> If this field is not selected then, only non-zero amount bills are displayed in search results.	No
Bill Date From	Used to search bills which are created from a particular date onwards.  <b>Note:</b> By default, the current system date appears in this field.	No
To	Used to search bills which are created till a particular date.  <b>Note:</b> By default, the current system date appears in this field.	No

Field Name	Field Description	Mandatory (Yes or No)
Address Source	Used to indicate the source of address. The valid values are: <ul style="list-style-type: none"> <li>Account Override</li> <li>Mailing Location on Account</li> <li>Person</li> </ul>	No
State	Used to indicate the state name.	No
County	Used to indicate the county name.	No
Postal	Used to indicate the postal or zip code.	No

**Note:**

You must specify at least one search criterion while searching for bills.

ORMB search engine supports wildcard search, where you can substitute the percentage (%) symbol as a stand in for any word or letter in a search criteria. You can use the ‘%’ wildcard character in all input fields except the date and ID fields. The ‘%’ wildcard character is suffixed automatically at the end of the partial search criteria. Therefore, you may or may not specify the wildcard character at the end of the partial search criteria. However, you have to prefix the wildcard character manually wherever required.

- **Search Results** — On clicking the **Search** button, the search results appear based on the specified search criteria.

The **Search Results** section contains the following columns:

Column Name	Column Description
Bill Information	Displays the bill information.
Account Information	Displays the account information.
Country	Displays the country name.
State	Displays the state name.
County	Displays the county name.
Postal	Displays the postal or zip code.
Entity ID	Displays the entity ID.

**Related Topics**

For more information on...	See...
How to search Bills	<a href="#">Searching Bills</a> on page 1539
How to view the log of a hold request	<a href="#">Viewing the Log of a Hold Request</a> on page 1553

**Search Person**

The **Search Person** zone searches for persons to add in a hold request. This zone contains the following sections:

- **Search Criteria** — This section contains the following fields:

Field Name	Field Description	Mandatory (Yes or No)
Search By	Displays the value as Person Details.	Not applicable



Field Name	Field Description	Mandatory (Yes or No)
Person ID	Used to search a particular person. <b>Note:</b> You can search for a person by clicking the <b>Search</b>  icon corresponding to the field.	No
State	Used to indicate the state name.	No
County	Used to indicate the county name.	No
Postal	Used to indicate the postal or zip code.	No

**Note:**

You must specify at least one search criterion while searching for persons.

ORMB search engine supports wildcard search, where you can substitute the percentage (%) symbol as a stand in for any word or letter in a search criteria. You can use the ‘%’ wildcard character in all input fields except the date and ID fields. The ‘%’ wildcard character is suffixed automatically at the end of the partial search criteria. Therefore, you may or may not specify the wildcard character at the end of the partial search criteria. However, you have to prefix the wildcard character manually wherever required.

- **Search Results** — On clicking the **Search** button, the search results appear based on the specified search criteria.

The **Search Results** section contains the following columns:

Column Name	Column Description
Person Information	Displays the person information.
Person Identifier Type	Displays the identifier type of the person linked to the account.
Person Identifier	Displays the ID of the person linked to the account.
Country	Displays the country name.
State	Displays the state name.
County	Displays the county name.
Postal	Displays the postal or zip code.
Entity ID	Displays the entity ID.

**Related Topics**

For more information on...	See...
How to search Persons	<a href="#">Searching Persons</a> on page 1538
How to view the log of a hold request	<a href="#">Viewing the Log of a Hold Request</a> on page 1553

**Hold Request - Log**

The **Log** tab on the **Hold Request** screen contains the following zone:

- [Hold Request Log](#) on page 1537

**Hold Request Log**

The **Hold Request Log** zone on the **Hold Request** screen lists the complete trail of actions performed on the hold request. This zone contains the following columns:

Column Name	Column Description
Date/Time	Displays the date and time when the action was performed on the hold request.
Details	Displays the details about the action performed on the hold request.
User	Indicates the user who has performed the action on the hold request.
Log Type	Indicates the type of log.
Related Object	Indicates the object or entity which is generated when the action is performed on the hold request.
Status Reason	Displays the status reason of action performed on the hold request.

**Note:** You can manually add a log entry for the hold request by clicking the **Add Log Entry** link in the upper right corner of the **Hold Request Log** zone.

The **Add Hold Request Log** window appears. Enter **Log Details** and click **Save**. The hold request log is added.

### Related Topics

For more information on...	See...
How to view the log of a hold request	<a href="#">Viewing the Log of a Hold Request</a> on page 1553

## Searching Persons

### Prerequisites

To search persons, you should have:

- Persons created in the application

### Procedure

To search for persons:

1. Search the hold requests for **Persons** that are having **Draft** status.
2. In the **Search Results** section, click the link in the **Hold Request Information** column corresponding to the hold request whose details you want to search.

The **Hold Request** screen appears.

3. Enter the search criteria in the **Search Person** zone.
4. Click **Search**.

A list of persons that meet the search criteria appears in the **Search Results** section.

### Related Topics

For more information on...	See...
<b>Hold Request</b> Screen	<a href="#">Hold Request (Used for Viewing)</a> on page 1528
<b>Hold Request</b> Zone	<a href="#">Hold Request</a> on page 1529
Adding Persons in a Hold Request	<a href="#">Adding Persons in a Hold Request</a> on page 1540

## Searching Accounts

### Prerequisites

To search accounts, you should have:

- Accounts created in the application

### Procedure

To search for accounts:

1. Search the hold requests for **Account** that are having **Draft** status.
2. In the **Search Results** section, click the link in the **Hold Request Information** column corresponding to the *hold* request whose details you want to search.

The **Hold Request** screen appears.

3. Enter the search criteria in the **Search Account** zone.
4. Click **Search**.

A list of accounts that meet the search criteria appears in the **Search Results** section.

### Related Topics

For more information on...	See...
<b>Hold Request</b> Screen	<a href="#">Hold Request (Used for Viewing)</a> on page 1528
<b>Hold Request</b> Zone	<a href="#">Hold Request</a> on page 1529
Adding Accounts in a Hold Request	<a href="#">Adding Accounts in a Hold Request</a> on page 1540

## Searching Bills

### Prerequisites

To search bills, you should have:

- Bills generated in the application

### Procedure

To search for bills:

1. Search the hold requests for **Bill** that are having **Draft** status.
2. In the **Search Results** section, click the link in the **Hold Request Information** column corresponding to the *hold* request whose details you want to search.

The **Hold Request** screen appears.

3. Enter the search criteria in the **Search Bill** zone.
4. Click **Search**.

A list of bills that meet the search criteria appears in the **Search Results** section.

### Related Topics

For more information on...	See...
<b>Hold Request</b> Screen	<a href="#">Hold Request (Used for Viewing)</a> on page 1528

For more information on...	See...
<b>Hold Request Zone</b>	<a href="#">Hold Request</a> on page 1529
Adding Bills in a Hold Request	<a href="#">Adding Bills in a Hold Request</a> on page 1541

## Adding Persons in a Hold Request

### Procedure

To add persons in a hold request:

1. Search for the hold request in the **Hold Request** screen which are having **Person** as a hold entity and **Draft as** status.
2. In the **Search Results** section, click the link in the **Hold Request Information** column corresponding to the hold request whose details you want to view.

The **Hold Request** screen appears.

3. Ensure the **Search Person** zone is expanded.
4. Enter the search criteria in the **Search Person** zone.

In the **Search Results** section, list of persons meeting the search criteria are displayed.

5. Select the persons which you want to add in the hold request and then click the **Add** button available in the upper left corner.

Selected persons are added in the hold request.

### Related Topics

For more information on...	See...
How to search for a hold request	<a href="#">Searching for a Hold Request</a> on page 1521
How to create a hold request	<a href="#">Creating a Hold Request</a> on page 1522
Search Person zone	<a href="#">Search Person</a> on page 1536
How to search for persons in a Hold Request Screen	<a href="#">Searching Persons</a> on page 1538

## Adding Accounts in a Hold Request

### Procedure

To add accounts in a hold request:

1. Search for the hold request in the **Hold Request** screen which are having **Account** as a hold entity and **Draft as** status.
2. In the **Search Results** section, click the link in the **Hold Request Information** column corresponding to the hold request whose details you want to view.

The **Hold Request** screen appears.

3. Ensure the **Search Account** zone is expanded.
4. Enter the search criteria in the **Search Account** zone.

In the **Search Results** section, list of accounts meeting the search criteria are displayed.

5. Select the accounts which you want to add in the hold request and then click the **Add** button available in the upper left corner.

Selected accounts are added in the hold request.

### Related Topics

For more information on...	See...
How to search for a hold request	<a href="#">Searching for a Hold Request</a> on page 1521
How to create a hold request	<a href="#">Creating a Hold Request</a> on page 1522
Search Account Zone	<a href="#">Search Account</a> on page 1532
How to search for accounts in a hold request	<a href="#">Searching Accounts</a> on page 1539

## Adding Bills in a Hold Request

### Procedure

To add bills in a hold request:

1. Search for the hold request in the **Hold Request** screen which are having **Bill** as a hold entity and **Draft** as status.
2. In the **Search Results** section, click the link in the **Hold Request Information** column corresponding to the hold request whose details you want to view.

The **Hold Request** screen appears.

3. Ensure the **Search Bill** zone is expanded.
4. Enter the search criteria in the **Search Bill** zone.

In the **Search Results** section, list of bills meeting the search criteria are displayed.

5. Select the bills which you want to add in the hold request and then click the **Add** button available in the upper left corner.

Selected bills are added in the hold request.

### Related Topics

For more information on...	See...
How to search for a hold request	<a href="#">Searching for a Hold Request</a> on page 1521
How to create a hold request	<a href="#">Creating a Hold Request</a> on page 1522
Search Bill Zone	<a href="#">Search Bill</a> on page 1535
How to search for bills in a hold request	<a href="#">Searching Bills</a> on page 1539

## Adding Processes in a Hold Request

### Prerequisites

To add processes in a hold request, you should have:

- Hold processes defined in the application.

### **Procedure**

To add processes in a hold request:

1. Search for the hold request in the **Hold Request** screen.
2. In the **Search Results** section, click the link in the **Hold Request Information** column corresponding to the hold request whose details you want to edit.

The **Hold Request** screen appears.

3. Click the **Edit** button in the **Hold Request** zone.

The **Hold Request** screen appears.

**Note:** The **Edit** button appears only when the hold request is in the **Draft** or **Active** status.

4. Ensure that the **Hold Processes** section is expanded when you are editing the hold request.
5. Select the required hold processes from the **Hold Process** field.
6. If you want to define more than one hold process for the hold request, click the **Add** (+) icon and then repeat step 5.

### **Note:**

However, if you want to remove a hold process from the hold request, click the **Delete** (🗑️) icon corresponding to the hold process.

Once we create active hold request for accounts on Overdue process, all existing active overdue processes will be inactive for those account.

7. Enter the required details.

### **Related Topics**

<b>For more information on...</b>	<b>See...</b>
How to search for a hold request	<a href="#">Searching for a Hold Request</a> on page 1521
How to create a hold request	<a href="#">Creating a Hold Request</a> on page 1522

## **Defining Characteristics for a Hold Request**

### **Prerequisites**

To define characteristics for a hold request, you should have:

- Characteristic types defined in the application (where the characteristic entity is set to **Hold Request**)

### **Procedure**

To define characteristics for a hold request:

1. Search for the hold request in the **Hold Request** screen.
2. In the **Search Results** section, click the link in the **Hold Request Information** column corresponding to the hold request whose details you want to edit.

The **Hold Request** screen appears.

3. Click the **Edit** button in the **Hold Request** zone.

The **Hold Request** screen appears.

**Note:** The **Edit** button appears only when the Hold request is in the **Draft** or **Active** status.

4. Ensure that the **Characteristics** section is expanded when you are editing the hold request.
5. Enter the required details in the **Characteristics** section.

**Note:** If you select a predefined characteristic type, the **Search** (🔍) icon appears corresponding to the **Characteristic Value** field. On clicking the **Search** icon, you can search for a predefined characteristic value.

6. If you want to define more than one characteristic for the hold request, click the **Add** (+) icon and then repeat step 5.

**Note:** However, if you want to remove a characteristic from the hold request, click the **Delete** (🗑️) icon corresponding to the characteristic.

### Related Topics

For more information on...	See...
How to search for a hold request	<a href="#">Searching for a Hold Request</a> on page 1521
How to create a hold request	<a href="#">Creating a Hold Request</a> on page 1522

## Editing a Hold Request

### Procedure

To edit a hold request:

1. Search for the hold request in the **Hold Request** screen.
2. In the **Search Results** section, click the link in the **Hold Request Information** column corresponding to the hold request whose details you want to edit.  
The **Hold Request** screen appears.
3. Click the **Edit** button in the **Hold Request** zone.

**Note:** The **Edit** button appears only when the hold request is in the **Draft** or **Active** status.

The **Hold Request** screen appears. It contains the following sections:

- **Main** — Used to specify basic details about the hold request. This section contains the following fields:

Field Name	Field Description	Mandatory (Yes or No)
Hold Request Information	Displays information about the hold request.	Not applicable
Hold Request Type	Displays the hold request type using which the hold request is created.	Not applicable

Field Name	Field Description	Mandatory (Yes or No)
Start Date	Used to specify the date till when you want to hold the entity.  <b>Note:</b> The hold entity end date must be between hold request start and end dates and between the process's start and end dates. The hold entity end date cannot be earlier than the hold entity start date.	Yes
End Date	Used to specify the date till when the hold request is effective.  <b>Note:</b> The hold request end date cannot be earlier than the hold request start date.	Yes
Hold Reason	Used to indicate the reason why you want to hold the entity.  <b>Note:</b> The hold reason must exist in the <b>HOLD_REASON_FLG</b> lookup field and its status must be <b>Active</b> .	Yes  <b>Note:</b> This field cannot be edited if hold request is in <b>Active</b> status.
Entity	Displays the hold entity.	Not applicable
Comments	Used to specify the additional information about hold request.	No

- **Hold Processes** — Used to specify the processes on hold in the hold request. This section contains the following fields:

Field Name	Field Description	Mandatory (Yes or No)
Hold Process	Used to indicate the process that needs to be kept on hold.	Yes
Start Date	Used to specify the date from when process is to be on hold for the hold request.  <b>Note:</b> This field is not editable when hold request is in <b>Active</b> status. The hold process start date must be between the hold request start and end dates.	Yes
End Date	Used to specify the date till when the hold process is to be on hold.	No

- **Characteristics** — Used to define characteristics for the hold request. This section contains the following fields:



Field Name	Field Description	Mandatory (Yes or No)
Effective Date	Used to specify the date from when the characteristic is effective for the hold request.	Yes (Conditional) <b>Note:</b> This field is required when you are defining a characteristic for the hold request.
Characteristic Type	Used to indicate the characteristic type. <b>Note:</b> The list includes only those characteristic types where the characteristic entity is set to <b>Hold Request</b> .	Yes (Conditional) <b>Note:</b> This field is required when you are defining a characteristic for the hold request.
Characteristic Value	Used to specify the value for the characteristic type. <b>Note:</b> On specifying the value for a predefined characteristic type, the description of the characteristic value appears corresponding to the <b>Characteristic Value</b> field.	Yes (Conditional) <b>Note:</b> This field is required when you are defining a characteristic for the hold request.

- Modify the details of the hold request, if required.

**Note:**

If you want to specify more than one hold processes, click the **Add** (+) icon corresponding to the process and then specify the details.

However, if you want to remove a hold process from the hold request, click the **Delete** (🗑️) icon corresponding to the process.

- Define, edit, or remove characteristics from the hold request, if required.
- Click **Save**.

The changes made to the hold request are saved.

### **Related Topics**

For more information on...	See...
How to search for a hold request	<a href="#">Searching for a Hold Request</a> on page 1521
<b>Hold Request</b> screen	<a href="#">Hold Request (Used for Searching)</a> on page 1518
<b>Hold Request</b> zone	<a href="#">Hold Request</a> on page 1529
How to define characteristics for a hold request	<a href="#">Defining Characteristics for a Hold Request</a> on page 1542

## **Editing Hold Request Entities**

### **Procedure**

To edit a hold request entities:

1. Search for the hold request in the **Hold Request** screen.
2. In the **Search Results** section, click the link in the **Hold Request Information** column corresponding to the hold request whose details you want to edit.

The **Hold Request** screen appears.

3. Select the entities that you want to edit in the **Hold Entities** zone and click the **Edit** button available in the upper left corner.

**Note:** The **Edit** button appears only when the hold request is in the **Draft** or **Active** status.

The **Edit Hold Request Entities** screen appears. It contains the following fields:

Field Name	Field Description	Mandatory (Yes or No)
Hold Request Information	Displays information about hold request.	Not applicable
Start Date	Displays the start date of hold request.	Not applicable
End Date	Displays the end date of hold request.	Not applicable

It also contains the following columns:

Column Name	Column Description	Mandatory (Yes or No)
Entity ID	Displays the entity ID.	Not applicable
Entity Information	Displays the information about the entity.	Not applicable
Start Date	Used to indicate the date from when the entity is on hold. <b>Note:</b> This field is not editable when hold request is in <b>Active</b> status.	Yes
End Date	Used to indicate the date till when the entity is on hold.	No
Hold Amount	Used to indicate the hold amount for bill. <b>Note:</b> This field appears only hold request is for bill.	Yes

4. Modify the details of the hold entities, if required.
5. Click **Save**.

The changes made to the hold entities are saved.

### **Related Topics**

For more information on...	See...
How to search for a hold request	<a href="#">Searching for a Hold Request</a> on page 1521
<b>Hold Request</b> screen	<a href="#">Hold Request (Used for Searching)</a> on page 1518
<b>Hold Request</b> zone	<a href="#">Hold Request</a> on page 1529

For more information on...	See...
How to define characteristics for a hold request	<a href="#">Defining Characteristics for a Hold Request</a> on page 1542

## Deleting Hold Request Entities

### Procedure

To delete hold request entities:

1. Search for the hold request in the **Hold Request** screen.
2. In the **Search Results** section, click the link in the **Hold Request Information** column corresponding to the hold request whose details you want to delete.

The **Hold Request** screen appears.

3. Select the entities to delete in the **Hold Entities** zone and click the **Delete** button available in the upper left corner.

A message appears confirming whether you want to delete the hold entity.

#### **Note:**

The **Delete** button appears only when the hold request is in the **Draft** or **Active** status.

4. Click **OK**.

The hold entities are deleted.

**Note:** No deletion is allowed on entities of hold requests which are in active status and are added from **Account Receivable Central** or **Delinquency Central**.

### Related Topics

For more information on...	See...
How to search for a hold request	<a href="#">Searching for a Hold Request</a> on page 1521
<b>Hold Request</b> screen	<a href="#">Hold Request (Used for Searching)</a> on page 1518
<b>Hold Request</b> zone	<a href="#">Hold Request</a> on page 1529
How to define characteristics for a hold request	<a href="#">Defining Characteristics for a Hold Request</a> on page 1542

## Deleting a Hold Request

### Procedure

To delete a hold request:

1. Search for the hold request in the **Hold Request** screen.
2. In the **Search Results** section, click the link in the **Hold Request Information** column corresponding to the hold request that you want to delete.

The **Hold Request** screen appears.

3. Click the **Delete** button in the **Hold Request** zone.

A message appears confirming whether you want to delete the hold request.

**Note:** The **Delete** button appears only when the hold request is in the **Draft** status.

4. Click **OK**.

The hold request is deleted.

**Note:**

You can delete a hold request only when its status is **Draft**.

Bills added from ARC cannot be deleted from the **Hold Request** screen.

### **Related Topics**

<b>For more information on...</b>	<b>See...</b>
How to search for a hold request	<a href="#">Searching for a Hold Request</a> on page 1521
<b>Hold Request</b> screen	<a href="#">Hold Request (Used for Searching)</a> on page 1518
<b>Hold Request</b> zone	<a href="#">Hold Request</a> on page 1529

## **Submitting a Hold Request**

### **Prerequisites**

To submit a hold request, you should have:

- Hold Request Types, Hold Processes and Hold Entities defined in the request.

### **Procedure**

To submit a hold request:

1. Search for the hold request in the **Hold Request** screen.
2. In the **Search Results** section, click the link in the **Hold Request Information** column corresponding to the *hold request* that you want to submit.

The **Hold Request** screen appears.

3. Click the **Submit** button in the **Hold Request** zone.

The system behaves in the following manner:

<b>If...</b>	<b>Then</b>
The <b>Approval Required</b> check box is selected in the hold request type using which the hold request is created.	A To Do of the <b>C1-HLDAP</b> To Do type is created and sent to the approver and the status of the hold request is changed to <b>Approval In Progress</b> .
The <b>Approval Required</b> check box is not selected in the hold request type using which the hold request is created.	The hold request is created using the specified hold request types and the status of the hold request is changed to <b>Active</b> or <b>Deferred Processing</b> as specified in the hold request type.

**Note:**

The **Submit** button appears only when the hold request is in the **Draft** status.

Once the request is activated, the **Release** button appears in the **Record Actions** section.

If hold request start date is in past and its status is draft then, on activation of the hold request, the start date is changed to the system date.

For Active hold request, **C1-DELBI** batch will delete all pending bill segments and bills under account for bill generation process.

For more information about the **Delete Pending Bill segments and Bills (C1-DELBI) batch**, refer to Oracle Revenue Management and Billing Batch Guide.

**Related Topics**

For more information on...	See...
How to search for a hold request	<a href="#">Searching for a Hold Request</a> on page 1521
<b>Hold Request</b> screen	<a href="#">Hold Request (Used for Searching)</a> on page 1518
<b>Hold Request</b> zone	<a href="#">Hold Request</a> on page 1529

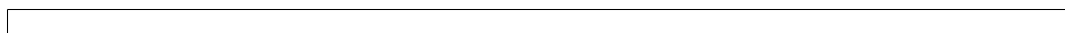
**Approving a Hold Request**

You can view the number of hold requests which are pending for approval in the **Hold Request** screen. The approver can review, and accordingly approve, reject or resubmit the hold request based on the observations.

**Note:** The system will not allow you to approve, reject or resubmit a hold request submitted by you.

**Procedure**

To approve a hold request:

1. Do either of the following:

If you want to...	Then...
Approve a hold request through the <b>Hold Request</b> screen	<ol style="list-style-type: none"> <li>1. Search for the hold request in the <b>Hold Request</b> screen.</li> <li>2. In the <b>Search Results</b> section, click the link in the <b>Hold Request Information</b> column corresponding to the hold request which you want to review.</li> </ol>
Approve a hold request from the <b>To Do List</b> screen	<ol style="list-style-type: none"> <li>1. Click the <b>Menu</b> link in the <b>Application</b> toolbar. A list appears.</li> <li>2. From the <b>Main</b> menu, select <b>To Do</b> and then click <b>To Do List</b>. The <b>To Do Type for User Search</b> window appears.</li> </ol>

If you want to...	Then...
	<ol style="list-style-type: none"> <li>3. Enter <b>C1-HLDAP</b> in the <b>To Do Type</b> field.</li> <li>4. Click the <b>Search</b> button corresponding to the <b>To Do Type</b> field. The <b>To Do List</b> screen appears.</li> <li>5. Select the <b>Open</b> option from the <b>Filter by</b> list to view all unassigned To Dos.</li> <li>6. Click the link in the <b>Message</b> column corresponding to the To Do of the hold request that you want to review.</li> </ol>

The **Hold Request** screen appears.

2. Review the hold request details.
3. Click the **Approve** button in the **Hold Request** zone.

The system behaves in the following manner:

If you are...	Then...
Approving a Hold request	The status of the hold request is changed to <b>Active</b> or <b>Deferred Processing</b> as specified in the hold request type.

**Note:**

The **Approve** button appears only when the hold request is in the **Approval In Progress** status.

You can also resubmit the hold request if any changes are required in the hold request. Upon clicking the **Resubmit** button, provide the comments to make the required changes for the hold request.

### Related Topics

For more information on...	See...
<b>Hold Request</b> screen	<a href="#">Hold Request (Used for Searching)</a> on page 1518
<b>Hold Request</b> zone	<a href="#">Hold Request</a> on page 1529
How to search for a hold request	<a href="#">Searching for a Hold Request</a> on page 1521

## Releasing a Hold Request

### Procedure

To release a hold request:

1. Search for the hold request in the **Hold Request** screen.
2. In the **Search Results** section, click the link in the **Hold Request Information** column corresponding to the hold request whose details you want to edit.

The **Hold Request** screen appears.

- Click the **Release** button in the **Hold Request** zone.

The **Release Reason** window appears. It contains the following fields:

Field Name	Field Description	Mandatory (Yes or No)
Release Reason	Used to indicate the reason for releasing the hold request.	Yes
Comments	Used to specify the additional comments on the release reason	No

- Ensure the required release reason.
- click **Save**.

The hold request is released.

**Note:**

The **Release** button appears only when the hold request is in the **Active** status.

Once the hold request is in **Released** status, the **End Date** of processes and entities gets updated.

### Related Topics

For more information on...	See...
How to search for a hold request	<a href="#">Searching for a Hold Request</a> on page 1521
How to create a hold request	<a href="#">Creating a Hold Request</a> on page 1522

## Rejecting a Hold Request

### Prerequisites

To reject a hold request, you should have:

- Rejection reasons defined in the application

**Note:**

While rejecting a hold request, you need to specify the reason why you want to reject the hold request. You can select the appropriate rejection reason only when you have defined the reasons for the **Rejected** status of the **C1-HoldRequest** business object in the **Status Reason** screen.

The system will not allow you to approve, reject or resubmit a hold request submitted by you.

### Procedure

To reject a hold request:

- Do either of the following:

If you want to	Then
Reject a hold request through the <b>Hold Request</b> screen	<ol style="list-style-type: none"> <li>Search for the hold request in the <b>Hold Request</b> screen.</li> <li>In the <b>Search Results</b> section, click the link in the <b>Hold Request Information</b> column</li> </ol>

If you want to	Then
	corresponding to the hold request which you want to review.
Reject a hold request from the <b>To Do List</b> screen	<ol style="list-style-type: none"> <li>1. Click the <b>Menu</b> link in the <b>Application</b> toolbar. A list appears.</li> <li>2. From the <b>Main</b> menu, select <b>To Do</b> and then click <b>To Do List</b>. The <b>To Do Type for User Search</b> window appears.</li> <li>3. Enter <b>C1-HLDAP</b> in the <b>To Do Type</b> field.</li> <li>4. Click the <b>Search</b> button corresponding to the <b>To Do Type</b> field. The <b>To Do List</b> screen appears.</li> <li>5. Select the <b>Open</b> option from the <b>Filter by</b> list to view all unassigned To Dos.</li> <li>6. Click the link in the <b>Message</b> column corresponding to the To Do of the hold request that you want to review.</li> </ol>

The **Hold Request** screen appears.

2. Review the hold request details.
3. Click the **Reject** button in the **Hold Request** zone.

The **Reject Hold Request** window appears. It contains following fields:

Field Name	Field Description	Mandatory (Yes or No)
Status Reason	Used to indicate the reason why you want to reject the hold request.	Yes
Comments	Used to specify additional information while rejecting the hold request.	No

**Note:** The **Reject** button appears only when:

- The hold request is in the **Approval In Progress** status.
- A user with the approval To Do role is reviewing the hold request.

4. Select the rejection reason from the **Status Reason** list.
5. Click **Save**.

The status of the hold request is changed to **Rejected**.

#### Related Topics

For more information on...	See...
How to search for a hold request	<a href="#">Searching for a Hold Request</a> on page 1521



For more information on...	See...
<b>Hold Request</b> screen	<a href="#">Hold Request (Used for Searching)</a> on page 1518
<b>Hold Request</b> zone	<a href="#">Hold Request</a> on page 1529

## Resubmitting a Hold Request

### Prerequisites

To resubmit a hold request, you should have:

- Entities added in the hold request which is submitted for approval.

While resubmitting, To Do will be sent to the submitter of the request using the submitter To Do Role mapped on the hold request type and the request will be moved to Draft status. The submitter can do necessary changes and re submit the request. Log will be maintained when the approver sends the request back to submitter.

### Procedure

To resubmit a hold request:

1. Search for the hold request in the **Hold Request** screen.
2. In the **Search Results** section, click the link in the **Hold Request Information** column corresponding to the hold request that you want to resubmit.

The **Hold Request** screen appears.

3. Click the **Re Submit** button in the **Hold Request** zone.

The **Resubmit Hold Request** screen appears.

**Note:** The **Re Submit** button appears only when the hold request is in the **Approval In Progress** status.

A To Do of the **C1-HOLSB** To Do type is created and sent to the request submitter using the submitter TO DO Role and the status of the hold request is changed to **Draft**.

4. Enter the comments in the respective field and click **Save**.

### Related Topics

For more information on...	See...
How to search for a hold request	<a href="#">Searching for a Hold Request</a> on page 1521
<b>Hold Request</b> screen	<a href="#">Hold Request (Used for Searching)</a> on page 1518
<b>Hold Request</b> zone	<a href="#">Hold Request</a> on page 1529
How to submit a hold request	<a href="#">Submitting a Hold Request</a> on page 1548

## Viewing the Log of a Hold Request

### Procedure

To view the log of a hold request:

1. Search for the hold request in the **Hold Request** screen.

- In the **Search Results** section, click the link in the **Hold Request Information** column corresponding to the *hold* request whose log you want to view.

The **Hold Request** screen appears. It consists of the following tabs:

- Main** – Displays information about the hold request. It contains the following zones:

- Hold Request** – Displays the details of the hold request.
- Hold Entities** – Lists the hold entities records of the hold request.
- Search Account** – Searches the accounts to be put on hold.

**Note:** This zone appears only when hold request is for **Account** and its status is **Draft**.

- Search Bill** – Searches the bills to be put on hold.

**Note:** This zone appears only when hold request is for **Bill** and its status is **Draft**.

- Search Person** – Searches the persons to be put on hold.

**Note:** This zone appears only when hold request is for **Person** and its status is **Draft**.

- Log** – Lists the complete trail of actions performed on the hold request. This tab contains the following zone:

- Hold Request Log** – Displays the trail of actions performed on the particular hold request.

- Click the **Log** tab.

The **Hold Request Log** zone in the **Log** tab contains the following columns:

Column Name	Column Description
Date/Time	Displays the date and time when the action was performed on the hold request.
Details	Displays the details about the action performed on the hold request.
User	Indicates the user who has performed the action on the hold request.
Log Type	Indicates the type of log.
Related Object	Indicates the object or entity which is generated when the action is performed on the hold request.
Status Reason	Indicates the reason why the hold request was rejected or voided.

**Note:** You can manually add a log entry for the hold request by clicking the **Add Log Entry** link in the upper right corner of the **Hold Request Log** zone.

### Related Topics

For more information on...	See...
How to search for a hold request	<a href="#">Searching for a Hold Request</a> on page 1521
How to add a log entry for a hold request	<a href="#">Adding a Log Entry for a Hold Request</a> on page 1554

## Adding a Log Entry for a Hold Request

### Procedure

To add a log entry for a hold request:

1. Search for the hold request in the **Hold Request** screen.
2. In the **Search Results** section, click the link in the **Hold Request Information** column corresponding to the hold request whose log you want to edit.

The **Hold Request** screen appears. It consists of the following tabs:

- **Main** – Displays information about the hold request. It contains the following zones:

- **Hold Request** – Displays the details of the hold request.
- **Hold Entities** – Lists the hold entities records of the hold request.
- **Search Account** – Searches the accounts to be put on hold.

**Note:** This zone appears only when hold request is for **Account** and its status is **Draft**.

- **Search Bill** – Searches the bills to be put on hold.

**Note:** This zone appears only when hold request is for **Bill** and its status is **Draft**.

- **Search Person** – Searches the persons to be put on hold.

**Note:** This zone appears only when hold request is for **Person** and its status is **Draft**.

- **Log** – Lists the complete trail of actions performed on the hold request. This tab contains the following zone:
  - **Hold Request Log** – Displays the trail of actions performed on the particular hold request.

3. Click the **Log** tab.

The **Log** tab appears.

4. Click the **Add Log Entry** link in the upper right corner of the **Hold Request Log** zone.

The **Add Hold Request Log** window appears. It contains the following fields:

Field Name	Field Description	Mandatory (Yes or No)
Hold Request Information	Displays information about the hold request.	Not applicable
Log Details	Used to specify additional comments on the hold request.	Yes

5. Enter the comments in the **Log Details** field.
6. Click **Save**.

The log entry is added in the **Hold Request Log** zone.

### **Related Topics**

For more information on...	See...
How to search for a hold request	<a href="#">Searching for a Hold Request</a> on page 1521



---

# Chapter 23

---

## Delinquency Central

---

### Topics:

- [Prerequisites](#)
- [Delinquency Central \(Used for Viewing\)](#)
- [Overdue Process Information for Account: {Account ID}](#)

Oracle Revenue Management and Billing provides a complete overview of the overdue bills belonging to the delinquent accounts of a particular person using the **Delinquency Central**. User can review the overdue bills and perform following actions from the delinquency central:

- Initiate customer contact
- Initiate hold on overdue process
- Create payment arrangement for an account
- Create promise to pay for person's account

The Delinquency Central assists you in identifying all the overdue processes, overdue bills & delinquent accounts using an overdue monitoring process.

For more information on how to setup the delinquency central, see [Prerequisites](#) on page 1558.

### **Related Topics**

For more information on...	See...
<b>Delinquency Central</b> screen	<a href="#">Delinquency Central (Used for Viewing)</a> on page 1558
<b>Overdue Process Information for Account: {Account ID}</b>	<a href="#">Overdue Process Information for Account: {Account ID}</a> on page 1565

## Prerequisites

---

To setup delinquency central, you need to do the following:

- Define the required characteristic types where the characteristic entity is set to overdue event.
- Define the overdue event type and overdue process template in the system.
- Promise To Pay type defined in the application.
- Customer contact type defined in the application.
- Hold request type defined in the application.

## Delinquency Central (Used for Viewing)

---

The **Delinquency Central** screen allows you to:

- Search for an overdue process
- View the details of an overdue process
- View the details of an overdue event
- Create customer contact
- Create a hold request for an overdue process
- Create a payment arrangement for an account
- Create a promise to pay for a person's account
- Create a payment agreement request for an account

This screen consists of the following zones:

- [Search Overdue Process](#)
- [Overdue Events](#)

### Search Overdue Process

The **Search Overdue Process** zone allows you to search for overdue processes using various search criteria. This zone contains the following two sections:

- **Search Criteria** — The **Search Criteria** section contains the following fields:

Field Name	Field Description	Mandatory (Yes or No)
Search By	<p>Used to indicate whether you want to search for overdue processes using person, account, bill or overdue process. The valid values are:</p> <ul style="list-style-type: none"> <li>• Person</li> <li>• Account</li> <li>• Bill</li> <li>• Overdue Process</li> </ul> <p><b>Note:</b> By default, the <b>Person</b> option is selected.</p>	No

Field Name	Field Description	Mandatory (Yes or No)
Person ID	Used to search for overdue processes which belong to a particular person.  <b>Note:</b> This field appears only when you select the <b>Person</b> option from the <b>Search By</b> list.	No
Person Identifier Type	Used to search for overdue processes with a particular person identifier type.  <b>Note:</b> This field appears only when you select the <b>Person</b> option from the <b>Search By</b> list.	Yes (Conditional)  <b>Note:</b> If you enter the person identifier as a search criteria, you have to select the person identifier type.
Person Identifier	Used to search for overdue processes with a specific value of the person identifier type.  <b>Note:</b> This field appears only when you select the <b>Person</b> option from the <b>Search By</b> list.	Yes
Account ID	Used to search for overdue processes created for a particular account.  <b>Note:</b> This field appears only when you select the <b>Account</b> option from the <b>Search By</b> list.	No
Account Identifier Type	Used to search for overdue processes with a particular account identifier type.  <b>Note:</b> This field appears only when you select the <b>Account</b> option from the <b>Search By</b> list.	Yes (Conditional)  <b>Note:</b> If you enter the account identifier as a search criteria, you have to select the account identifier type.
Account Identifier	Used to search for overdue processes with a particular account identifier.  <b>Note:</b> This field appears only when you select the <b>Account</b> option from the <b>Search By</b> list.	Yes
Bill ID	Used to search for overdue processes with a particular bill.  <b>Note:</b> This field appears only when you select the <b>Bill</b> option from the <b>Search By</b> list.	No
Alternate Bill ID	Used to search for overdue processes using an alternate bill ID.  <b>Note:</b> This field appears only when you select the <b>Bill</b> option from the <b>Search By</b> list.	No

Field Name	Field Description	Mandatory (Yes or No)
Characteristic Type / Value	Used to search for overdue processes with a particular characteristic type and its value.  <b>Note:</b> This field appears only when you select the <b>Bill</b> option from the <b>Search By</b> list.	No
Overdue Process Template	Used to search for overdue processes with a particular overdue process template.  <b>Note:</b> This field appears only when you select the <b>Overdue Process</b> option from the <b>Search By</b> list.	No
Start Date	Used to search for overdue processes with a particular start date.  <b>Note:</b> This field appears only when you select the <b>Overdue Process</b> option from the <b>Search By</b> list.	Yes
End Date	Used to search overdue process with a particular end date.  <b>Note:</b> This field appears only when you select the <b>Overdue Process</b> option from the <b>Search By</b> list.	Yes
Status	Used to search for overdue processes with a particular status. The valid values are: <ul style="list-style-type: none"> <li>• Active</li> <li>• Inactive</li> </ul> <b>Note:</b> This field appears only when you select the <b>Overdue Process</b> option from the <b>Search By</b> list.	No
On Hold	Used to search for overdue processes that are on hold.  <b>Note:</b> This field appears only when you select the <b>Overdue Process</b> option from the <b>Search By</b> list.	No
Overdue Amount From	Used to search for overdue processes with a particular lower limit of the overdue amount.  <b>Note:</b> This field appears only when you select the <b>Overdue Process</b> option from the <b>Search By</b> list.	No
To	Used to search for overdue processes with a particular higher limit of the overdue amount.  <b>Note:</b> This field appears only when you select the <b>Overdue Process</b> option from the <b>Search By</b> list.	No



Field Name	Field Description	Mandatory (Yes or No)
Characteristic Type / Value	Used to search for overdue processes with a particular characteristic type and value.  <b>Note:</b> This field appears only when you select the <b>Overdue Process</b> option from the <b>Search By</b> list.	No

- In addition to above search parameters, the screen consists of following fields in the **Person Details** or **Account Details** section:

Column Name	Column Description
Main Customer	Displays the name of the main customer to whom the account belongs.  <b>Note:</b> This field appears only when you select the <b>Account</b> option from the <b>Search By</b> list.
Person Name	Displays the name of the person to whom the account belongs.  <b>Note:</b> This field appears only when you select the <b>Person</b> option from the <b>Search By</b> list.
Person Identifier Type	Displays the person identifier type.  <b>Note:</b> This field appears only when you select the <b>Person</b> or <b>Account</b> option from the <b>Search By</b> list.
Person Identifier	Displays the value of the person identifier type.  <b>Note:</b> This field appears only when you select the <b>Person</b> or <b>Account</b> option from the <b>Search By</b> list.
Account Identifier Type	Displays the account identifier type.  <b>Note:</b> This field appears only when you select the <b>Account</b> option from the <b>Search By</b> list.
Account Identifier	Displays the value of the account identifier type.  <b>Note:</b> This field appears only when you select the <b>Account</b> option from the <b>Search By</b> list.
Overdue	Displays whether the person account(s)/bill(s) are overdue. The valid values are: <ul style="list-style-type: none"> <li>• Yes</li> <li>• No</li> </ul> <b>Note:</b> This field appears only when you select the <b>Person</b> or <b>Account</b> option from the <b>Search By</b> list.
Number of Active Overdue processes	Displays the number of overdue processes linked to the person's account that are in active status.  <b>Note:</b> This field appears only when you select the <b>Person</b> or <b>Account</b> option from the <b>Search By</b> list.

Column Name	Column Description
Number of Hold(s) on Account(s)	Displays the number of hold requests on the particular account.
Number of Overdue Bills	Displays the total number of bills that are overdue. <b>Note:</b> This field appears only when you select the <b>Person</b> or <b>Account</b> option from the <b>Search By</b> list.
Total Overdue Amount	Displays the total overdue amount for an account.
Last Payment Date	Displays date of the last payment made by the person. <b>Note:</b> This field appears only when you select the <b>Person</b> or <b>Account</b> option from the <b>Search By</b> list.
Last Payment Amount	Displays the amount last paid by the person. <b>Note:</b> This field appears only when you select the <b>Person</b> or <b>Account</b> option from the <b>Search By</b> list.
Number Of Payment Arrangements	Displays the number of payment arrangements for the person's account. <b>Note:</b> This field appears only when you select the <b>Person</b> or <b>Account</b> option from the <b>Search By</b> list.
Total Number of Overdue Process on Hold	Displays the total number of overdue process that are on hold. <b>Note:</b> This field appears only when you select the <b>Person</b> or <b>Account</b> option from the <b>Search By</b> list.
Number of Promise To Pay	Displays the number of promise to pay belonging to the person. <b>Note:</b> This field appears only when you select the <b>Person</b> or <b>Account</b> option from the <b>Search By</b> list.
Number of Broken Promise To Pay	Displays the total number of promise to pay that are broken. <b>Note:</b> This field appears only when you select the <b>Person</b> or <b>Account</b> option from the <b>Search By</b> list.

- **Search Results** — On clicking the **Search** button, the search results appear based on the specified search criteria. The **Search Results** section contains the following columns:

Column Name	Column Description
Overdue Process	Display additional information about the overdue process. <b>Note:</b> It has a link. On clicking the link, the <b>Overdue Process</b> screen appears where you can view the details of the overdue process.
Overdue Process Template	Displays the template that was used to create overdue process's events.

Column Name	Column Description
Account Information	Display additional information about the account. In addition, this column has a context menu which helps in navigating to other screens in the application. <b>Note:</b> It has a link. On clicking the link, the <b>Account</b> screen appears with the details of the account.
Person Information	Display additional information about the person. In addition, this column has a context menu which helps in navigating to other screens in the application. <b>Note:</b> It has a link. On clicking the link, the <b>Person</b> screen appears with the details of the person.
Overdue Amount	Displays the overdue amount under that overdue process.
On Hold	Displays whether the overdue process is on hold.
Overdue Process Details	On clicking the <b>View</b>  icon, the <b>Overdue Process Details</b> screen appears where you can view details of the overdue process.

On clicking the **Broadcast**  icon corresponding to the overdue process, the **Overdue Events** zone appears with the details of the respective overdue process.

### Related Topics

For more information on...	See...
<b>Overdue Events</b> screen	<a href="#">Overdue Events</a> on page 1563
How to search for a bill	<a href="#">Searching for a Bill</a> on page 1569
How to view events of an overdue process	<a href="#">Viewing Events of an Overdue Process</a> on page 1564
How to view details of an overdue process	<a href="#">Viewing the Overdue Process Details</a> on page 1565

## Overdue Events

The **Overdue Events** zone displays the details of the events of the overdue process on the **Delinquency Central** screen.

Column Name	Column Description
Event	Displays information about the event of the overdue process.
Event Status	Displays the status of the event.
Dependency on Other Events	Displays whether the event is dependent on other events. The valid values are: <ul style="list-style-type: none"> <li>• No</li> <li>• Yes</li> </ul>
Trigger Date	Displays the trigger date of the event.

### Related Topics

For more information on...	See...
<b>Delinquency Central</b> screen	<a href="#">Delinquency Central (Used for Viewing)</a> on page 1558
How to view events of an overdue process	<a href="#">Viewing Events of an Overdue Process</a> on page 1564

## Searching for an Overdue Process

### Prerequisites

To search for an overdue process, you should have:

- Overdue process defined in the application.

### Procedure

To search for an overdue process:

1. Click the **Menu** link in the **Application** toolbar
2. From the **Main** menu, select **Credits & Collection** and then click **Delinquency Central**.

The **Delinquency Central** screen appears.

3. Enter the search criteria in the **Search Overdue Process** zone.

**Note:** ORMB search engine supports wildcard search, where you can substitute the percentage (%) symbol as a stand in for any word or letter in a search criteria. You can use the ‘%’ wildcard character in all input fields except the date and ID fields. The ‘%’ wildcard character is suffixed automatically at the end of the partial search criteria. Therefore, you may or may not specify the wildcard character at the end of the partial search criteria. However, you have to prefix the wildcard character manually wherever required.

4. Click **Search**.

A list of overdue processes that meet the search criteria appear in the **Search Results** section.

### Related Topics

For more information on...	See...
<b>Delinquency Central</b> screen	<a href="#">Delinquency Central (Used for Viewing)</a> on page 1558
<b>Search Overdue Process</b> zone	<a href="#">Search Overdue Process</a> on page 1558

## Viewing Events of an Overdue Process

### Procedure

To view events of an overdue process:

1. Search for the overdue process in the **Delinquency Central** screen.
2. In the **Search Results** section, click the **Broadcast**  icon corresponding to the overdue process whose event details you want to view.

The **Overdue Events** zone appears.

3. View the overdue event details of the overdue process in the **Overdue Events** zone.

### Related Topics

For more information on...	See...
<b>Delinquency Central</b> screen	<a href="#">Delinquency Central (Used for Viewing)</a> on page 1558
<b>Overdue Events</b> screen	<a href="#">Overdue Events</a> on page 1563
How to search for an overdue process	<a href="#">Searching for an Overdue Process</a> on page 1564

## Viewing the Overdue Process Details

### Procedure

To view the details of an overdue process:

1. Search for the overdue process in the **Delinquency Central** screen.
2. In the **Search Results** section, click the link in the **Overdue Process Information** column corresponding to the overdue process whose details you want to view.

The **Overdue Process** screen appears. It consists of the following tabs:

- **Main** – Displays the basic details of the overdue process.
  - **Events** – Displays the events details of the overdue process.
  - **Log** – Displays a complete trail of actions performed on the overdue process.
  - **Characteristics** – Displays the characteristics of the overdue process.
3. View the event details of the overdue process in the **Overdue Process** screen.

### Related Topics

For more information on...	See...
<b>Delinquency Central</b> screen	<a href="#">Delinquency Central (Used for Viewing)</a> on page 1558
How to search for an overdue process	<a href="#">Searching for an Overdue Process</a> on page 1564

## Overdue Process Information for Account: {Account ID}

---

The **Overdue Process Information for Account: {Account ID}** screen allows you to view detail information of the account which is linked to the overdue process.

This screen consists of the following zones:

- [Person Information](#) on page 1566
- [Account Information](#) on page 1566
- [Customer Contact Details](#) on page 1566
- [Promise To Pay](#) on page 1566
- [Hold Details](#) on page 1567
- [Overdue Bills](#) on page 1567
- [Payment Arrangement](#) on page 1568
- [Search Bill](#) on page 1568
- [Searching for a Bill](#) on page 1569
- [Adding the Customer Contact Details](#) on page 1570
- [Creating a Hold Request for an Overdue Process](#) on page 1570
- [Creating a Payment Agreement Request for an Overdue Process](#)

- [Defining a Promise To Pay for an Overdue Process](#) on page 1571

## Person Information

The **Person Information** zone displays details of the person whose account is linked to the overdue process. This zone contains following columns:

Column Name	Column Description
Person Name	Displays the name of the person whose account is linked to the overdue process.
Phone Number	Displays the phone number of the person.
Address	Displays the address of the person.

## Account Information

The **Account Information** zone displays the details of the account that is linked with the overdue process. This zone contains following columns:

Column Name	Column Description
Account ID	Displays the account ID.
Account Identifier Type	Displays the account identifier type.
Account Identifier	Displays the value of the account identifier type.
Last Payment Date	Displays the date of the last payment made from the account that is linked with the overdue process.
Last Payment Amount	Displays the amount last paid from the account.

## Customer Contact Details

The **Customer Contact Details** zone displays the contact details of the customer whose account is linked with the overdue process. This zone contains following columns:

Column Name	Column Description
Contact Date/Time	Displays the date and time when the customer was contacted.
Customer Contact Information	Displays additional information about the customer contact. <b>Note:</b> It has a link. On clicking the link, the <b>Customer Contact</b> screen appears where you can view the details of the respective customer contact.
Preferred Contact Method	Displays the preferred method of contacting the customer.
Comments	Displays the comments that are placed against each customer.

## Promise To Pay

The **Promise To Pay** zone displays promise to pay created for an account which is linked to the overdue process. This zone contains following columns:

Column Name	Column Description
Promise To Pay Information	Displays additional information of promise to pay. <b>Note:</b> It has a link. On clicking the link, the <b>Promise To Pay</b> screen appears where you can view the details of promise to pay.
Scheduled Amount	Displays the amount to be paid on the <b>Scheduled Date</b> .
Scheduled Date	Displays the date when the payment is expected as per promise to pay.
Status	Displays the status of promise to pay.
Created By	Displays the user ID who has created the promise to pay.

## Hold Details

The **Hold Details** zone displays the details of the person whose account is linked to the overdue process. This zone contains the following columns:

Column Name	Column Description
Hold Request Information	Displays additional information about the hold request. <b>Note:</b> It has a link. On clicking the link, the <b>Hold Request</b> screen appears where you can view the details of the hold request.
Status	Displays the status of the hold request.
Entity	Displays the hold request entity.
Entity Information	Displays the information about the entity on hold. <b>Note:</b> It has a link. On clicking the link, the <b>Account, Bill</b> or <b>Person</b> screen appears, where you can view details of the respective account, bill or person.
Start Date	Displays the date when the hold request is created.
End Date	Displays the end date of the hold request.

## Overdue Bills

The **Overdue Bills** zone displays details of the overdue bills. This zone contains following columns:

Column Name	Column Description
Bill Information	Displays additional information about the bill. <b>Note:</b> It has a link. On clicking the link, the <b>Bill</b> screen appears where you can view the details of the respective bill.
Original Bill Amount	Displays the bill amount when the bill was generated.
Due Date	Displays the due date of the bill.
Overdue Amount	Displays the amount that is overdue in the bill.
Days Past Due	Displays the number of days past after the bill date.

## Payment Arrangement

The **Payment Arrangement** zone displays the details of the payment arrangement that is created for an account linked to the overdue process. This zone contains following columns:

Column Name	Column Description
Contract Information	Displays the payment arrangement contract information . In addition, this column has a context menu which helps in navigating to other screens in the application.  <b>Note:</b> It has a link. On clicking the link, the <b>Contract</b> screen appears where you can view the details of the respective contract.
Payoff Balance	Displays the total amount that is paid against the payment arrangement contract.
Arrange Amount	Displays the amount that is paid in installments as per the payment arrangement contract.
Number of Installments	Displays the number of installments used to calculate the <b>Arrange Amount</b> .

## Search Bill

The **Search Bill** zone allows you to search for a bill. This zone contains the following fields:

- **Search Criteria** — The **Search Criteria** section contains the following fields:

Field Name	Field Description	Mandatory (Yes or No)
Person Name	Used to specify the name of the person for whom the bill is generated.	No
Person ID	Used to specify the person ID.	No
Bills of Persons in Hierarchy	Used to indicate whether you want to search for a bills generated against a person's hierarchy.	No
Bill Cycle	Used to indicate bills where a particular bill cycle is defined.	No
Bill Currency	Used to indicate the bill currency.	No
Billing Method	Used to indicate the billing method. The valid values are: <ul style="list-style-type: none"> <li>• Ad-Hoc Billing</li> <li>• Regular Billing</li> </ul>	No
Bill ID	Used to specify the bill ID.	No
Alternate Bill ID	Used to search a particular bill using the alternate bill ID.	No
Account ID	Used to indicate the account against which the bill is generated.	No
On or After Bill Date	Used to specify the date when the bill was completed.	No
Account Identifier Type	Used to search for bills where the account against which it is generated, a particular account identifier type is defined.	No



Field Name	Field Description	Mandatory (Yes or No)
Account Identifier	Used to search for a bill generated against an account with a particular account identifier.	No

**Note:** You must specify at least one search criterion while searching for the bill.

- **Search Results** — On clicking the **Search** button, the search results appear based on the specified search criteria. The **Search Results** section contains the following columns:

Column Name	Column Description
Person Name	Displays the name of the person against whom the bill is generated.
Bill ID	Displays the bill ID.
Bill Status	Displays the status of the bill. The valid values are: <ul style="list-style-type: none"> <li>• Pending</li> <li>• Complete</li> </ul>
Bill Date	Displays the date when the bill was completed.
Due Date	Displays the due date of the bill.
Current Charges	Displays the bill amount.
Bill Information	Displays additional information about the bill.

## Searching for a Bill

### Procedure

To search for a bill:

1. Click the **Menu** link in the **Application** toolbar.  
A list appears.
2. From the **Main** menu, select **Credits & Collections** and then click **Delinquency Central**.  
The **Delinquency Central** screen appears.
3. Select the **Bill** option from the **Search By** list.

**Note:** ORMB search engine supports wildcard search, where you can substitute the percentage (%) symbol as a stand in for any word or letter in a search criteria. You can use the ‘%’ wildcard character in all input fields except the date and ID fields. The ‘%’ wildcard character is suffixed automatically at the end of the partial search criteria. Therefore, you may or may not specify the wildcard character at the end of the partial search criteria. However, you have to prefix the wildcard character manually wherever required.

4. Click **Search**.  
A list of bills that meet the search criteria appear in the **Search Results** section.

### Related Topics

For more information on...	See...
<b>Delinquency Central</b> screen	<a href="#">Delinquency Central (Used for Viewing)</a> on page 1558
<b>Search Overdue Process</b> zone	<a href="#">Search Overdue Process</a>

## Adding the Customer Contact Details

### Procedure

To add customer contact details:

1. Search for an overdue process in the **Delinquency Central** screen.
2. In the **Search Results** section, select the check box corresponding to the overdue process linked to the account for which you want to add the customer contact.
3. Click **Contact Customer**.

The **Customer Contact** screen appears.

4. Enter the required details.

The fields **Person ID**, **Contact Date/Time** and **User ID** are auto-populated.

5. Click **Save**.

The customer is contacted based on the value set for **Preferred Contact Method** field on the **Customer Contact** screen.

### Related Topics

For more information on...	See...
<b>Delinquency Central</b> screen	<a href="#">Delinquency Central (Used for Viewing)</a> on page 1558

## Creating a Hold Request for an Overdue Process

### Procedure

To create a hold request for an overdue process:

1. Search for an overdue process in the **Delinquency Central** screen.
2. In the **Search Results** section, select the check box corresponding to the **Overdue Process Information** column for whom you want to create a hold request for an overdue process.
3. Click **Create Hold Request** button.

The **Add Hold Request** screen appears. It contains the following field:

Field Name	Field Description	Mandatory
Hold Request Type	Used to indicate the hold request type that is used for creating a hold request.	Yes

4. Select the required hold request type from the **Hold Request Type** field.
5. Click **OK**.

The **Hold Request** screen appears.

6. Enter the required details for an overdue process.
7. Click **Save**.

A hold request is defined for an overdue process where the status of the hold request is set as **Draft**.

**Note:**

The **Hold Request** screen appears where you can view the details of the hold request.

**Related Topics**

For more information on...	See...
<b>Delinquency Central</b> screen	<a href="#">Delinquency Central (Used for Viewing)</a> on page 1558
<b>Hold Request</b> screen	<a href="#">Hold Request (Used for Searching)</a> on page 1518
How to search for an overdue process	<a href="#">Searching for an Overdue Process</a> on page 1564

**Creating a Payment Arrangement for an Overdue Process****Procedure**

To create a payment arrangement for an overdue process:

1. Search for the overdue process in the **Delinquency Central** screen.
2. In the **Search Results** section, select the check box corresponding to the **Overdue Process Information** column for whom you want to create a payment arrangement for an overdue process.
3. Click the **Create Payment Arrangement** button.

The **Payment Arrangement** screen appears. It contains the following tabs:

- **Main**
- **History**

4. Enter the required details in the **Payment Arrangement** screen.
5. Click the **Save** button in the **Page Title** area of the **Payment Arrangement** screen.

A payment arrangement is created with the respective payment arrangement contract.

**Note:** The **Payment Arrangement** screen appears with the details of the payment arrangement.

**Related Topics**

For more information on...	See...
<b>Delinquency Central</b> screen	<a href="#">Delinquency Central (Used for Viewing)</a> on page 1558
How to search for an overdue process	<a href="#">Searching for an Overdue Process</a> on page 1564

**Defining a Promise To Pay for an Overdue Process****Procedure**

To create a promise to pay for an overdue process:

1. Search for the overdue process in the **Delinquency Central** screen.
2. In the **Search Results** section, select the check box corresponding to the **Overdue Process Information** column for whom you want to define a promise to pay for an overdue process.
3. Click the **Create Promise To Pay** button.

A message appears confirming that the promise to pay will be created for the account for which the overdue process is initiated.

4. Click **OK**.

The **Promise To Pay** screen appears.

5. Enter the required details in the **Promise To Pay** screen.

6. Click the **Save** button in the **Page Title** area of the **Promise To Pay** screen.

A promise to pay is created with the scheduled payment details.

**Related Topics**

<b>For more information on...</b>	<b>See...</b>
<b>Delinquency Central</b> screen	<a href="#">Delinquency Central (Used for Viewing)</a> on page 1558
<b>Promise To Pay</b> screen	<a href="#">Promise To Pay</a>
How to search for an overdue process	<a href="#">Searching for an Overdue Process</a> on page 1564

---

# Chapter

# 24

---

## Upload Request

---

### Topics:

- [Upload Request \(Without Approval\) Status Transition](#)
- [Upload Request \(With Approval\) Status Transition](#)
- [Prerequisites](#)
- [Algorithms Used in C1-BillCycleUpdateUplReq](#)
- [Algorithms Used in C1-ContractRiderUpdateUplReq](#)
- [Algorithms Used in C1-HoldUploadRequest](#)
- [Algorithms Used in C1-RefundUploadRequest](#)
- [Algorithms Used in C1-WriteOffUploadRequest](#)
- [Algorithms Used in C1-BillableChargeUploadRequest](#)
- [Algorithms Used in C1-ReinstatementUploadRequest](#)
- [Algorithms Used in C1-BillGrpSortUploadRequest](#)
- [Algorithms Used in C1-BillLevelUploadRequest](#)
- [CSV File Format for Account Bill Cycle Upload Request](#)
- [CSV File Format for Contract Rider Upload Request](#)
- [CSV File Format for Billable Charge Upload](#)
- [CSV File Format for Hold Upload Request](#)
- [CSV File Format for Refund Request Upload](#)

Oracle Revenue Management and Billing provides a generic upload feature which enables you to upload various types of data. The system enables you to upload data for the following using the **Upload Request** feature:

- Billable Charge (Adhoc and Regular)
- Hold Request
- Refund Request
- Write Off Request
- Policy Reinstatement
- Bill Group Sort ID
- Derivation and Pricing Parameters for a Bill Group and Sort ID Combination

It also enables you to update the following information:

- Contract rider of a contract
- Bill cycle of an account

While uploading data for the above supported entities, you need to specify the upload request type using which you want to upload the file. It is the upload request type which helps the system to determine:

- Whether the file must be approved by the approver before creating or updating the entities
- Which business object must be used for creating the upload request
- Which business object must be used for creating or updating entities through an upload request
- Which foreign key reference must be used for generating information string for the entity
- A set of fields using which you can search records uploaded through an upload request

You can upload a data file in the CSV format. You cannot upload data for more than one entity type through the same CSV file. For example, you cannot upload data for billable charges and hold requests using a single CSV file. An upload request of the specified upload request type is created when the file is successfully uploaded in the system. You can track a file through an upload request.

Once an upload request is created, the status of the upload request is set to **Draft**. The status of each record uploaded through an upload request is set to **Pending**. However, if the mandatory data is not available or data required for deriving

- [CSV File Format for Write Off Request Upload](#)
- [CSV File Format for Reinstatement Upload Request](#)
- [CSV File Format for Bill Group Sorting Upload Request](#)
- [CSV File Format for Bill Group Derivation and Pricing Parameters Upload Request](#)
- [Upload Request Type](#)
- [Upload Request \(Used for Searching\)](#)
- [Upload Request \(Used for Viewing\)](#)

mandatory data is incorrect in the record, the status of record is set to **Invalid**. You can then edit, delete, or validate the upload request. During the validation process, the system and custom validations (if any) are executed. The status of each record is changed to **Valid** or **Invalid** depending on whether the record was validated successfully or not.

Once the upload request is validated, you can either cancel or submit the upload request for further processing. On submitting an upload request, the system checks whether the number of valid records in the uploaded file exceed the online record process limit defined in the Defer Upload Request algorithm. If the number of valid records in the uploaded file does not exceed the online record process limit, the system creates or updates the entities in the real time (i.e. immediately). However, if the number of valid records in the uploaded file exceeds the online record process limit, the system creates or updates the entities in the deferred mode (i.e. when the **Upload Request Periodic Monitor (C1-UPLRQ)** batch is invoked).

You can optionally configure the system to use the approval workflow process for an upload request. If the **Approval Required** flag is set to **Yes** in an upload request type, then on submitting the respective upload request, the approval workflow process creates a To Do for the approver to review the upload request. Once the approver approves the upload request, the system checks whether the number of valid records in the uploaded file exceed the online record process limit defined in the Defer Upload Request algorithm. If the number of valid records in the uploaded file does not exceed the online record process limit, the system creates or updates the entities in the real time (i.e. immediately). However, if the number of valid records in the uploaded file exceeds the online record process limit, the system creates or updates the entities in the deferred mode (i.e. when the **Upload Request Periodic Monitor (C1-UPLRQ)** batch is invoked. However, if the approver rejects the upload request, the status of the upload request is set to **Rejected**.

During the upload process, an upload request goes through various statuses in its lifecycle. Note that the lifecycle of an upload request is driven by the business object using which the upload request is created. In this release, we have shipped the following upload request business objects:

- Update Bill Cycle Upload Request (C1-BillCycleUpdateUplReq)
- Billable Charge Upload Request (C1-BillableChargeUploadRequest)
- Update Contract Rider Upload Request (C1-ContractRiderUpdateUplReq)
- Hold Request Upload Request (C1-HoldUploadRequest)
- Refund Request Upload Request (C1-RefundUploadRequest)
- Write Off Request Upload Request (C1-WriteOffUploadRequest)
- Reinstatement Upload Request (C1-ReinstatementUploadRequest)
- Bill Group Sorting Upload Request (C1-BillGrpSortUploadRequest)
- Bill Group Derivation and Pricing Parameters Upload Request (C1-BillLevelUploadRequest)

During the upload request process, an upload request creation goes through various statuses in its lifecycle. For more information about the upload request statuses, see [Upload Request \(Without Approval\) Status Transition](#) on page 1576 and [Upload Request \(With Approval\) Status Transition](#) on page 1577.

**Note:** The lifecycle of an upload request creation is driven by the respective business object using which the request is created. The upload request feature explained in this document is articulated based on the lifecycle and logic defined in the business objects.

For more information on how to setup the upload request process, see [Prerequisites](#) on page 1578.

## Upload Request (Without Approval) Status Transition

The following figure graphically indicates how an upload request moves from one status to another when the approval workflow is off:

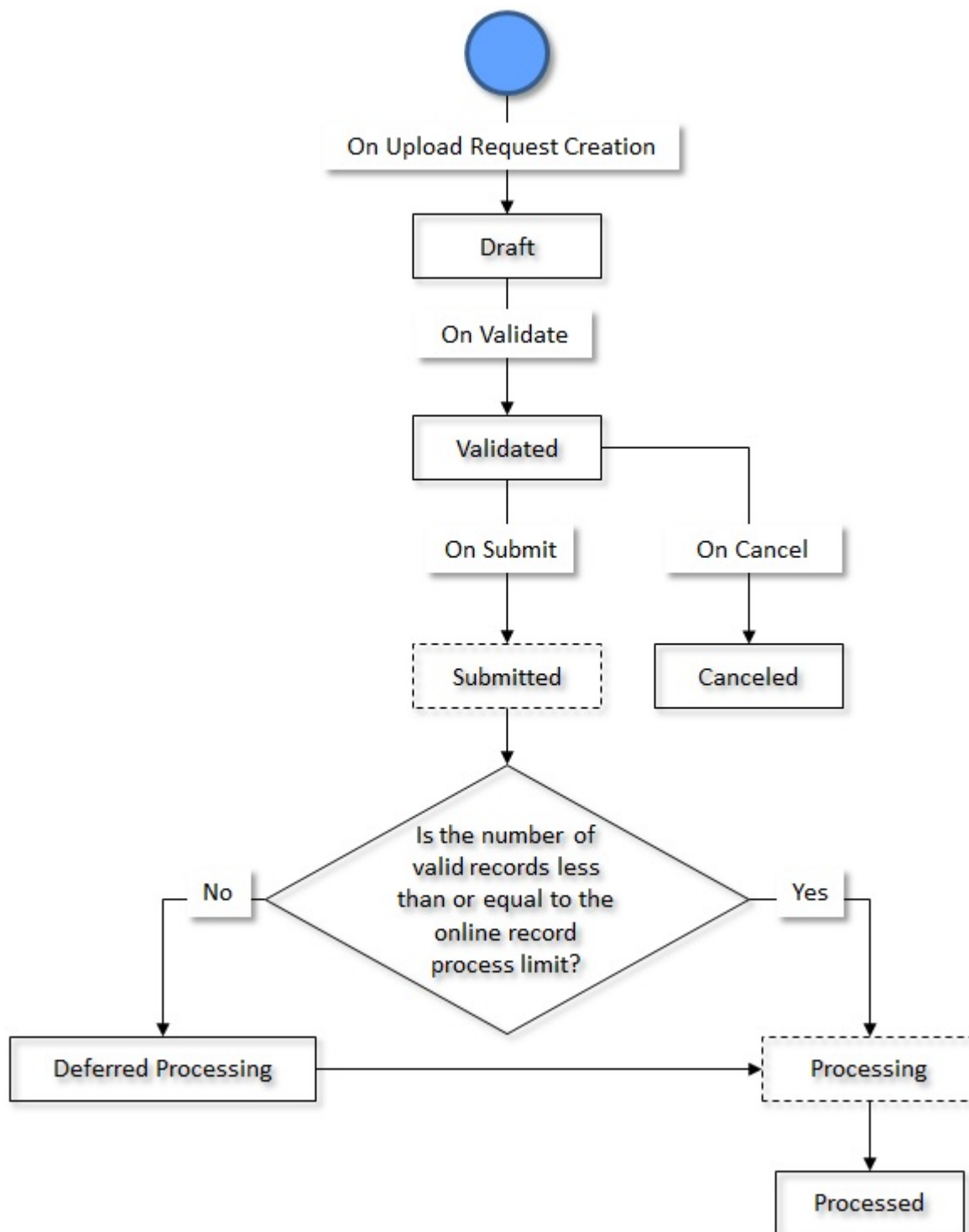



## Upload Request (With Approval) Status Transition

The following figure graphically indicates how an upload request moves from one status to another when the approval workflow is on:

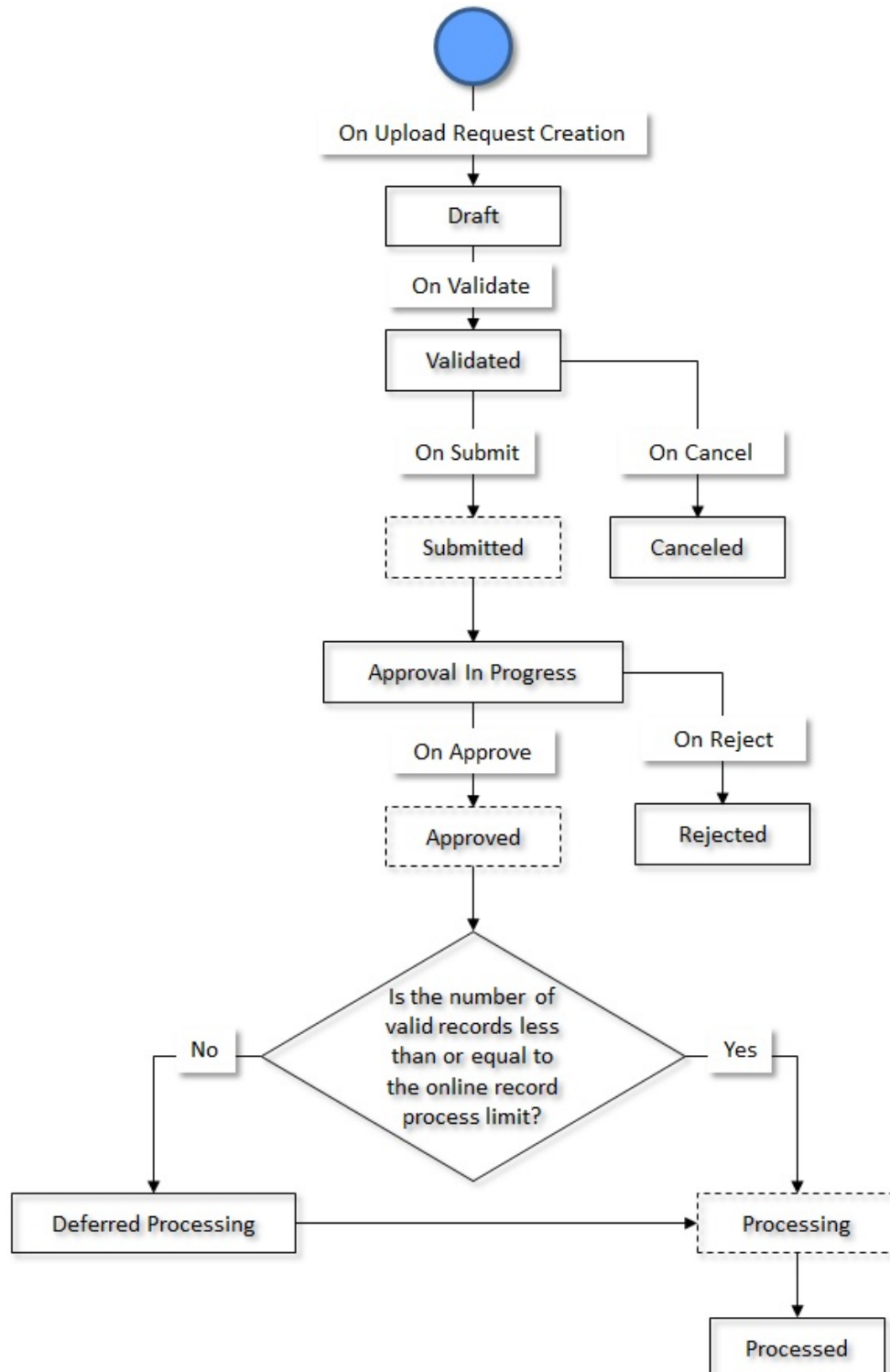

## Prerequisites

---

To setup the upload request process, you need to do the following:

- Define the required upload request types in the system.
- Define the required characteristic types where the characteristic entity is set to **Upload Request Type**.
- Define the required characteristic types where the characteristic entity is set to **Upload Request**.
- Define the values for the following parameters in the **C1-REN-VALID** algorithm:
  - Policy Status after Processing Reinstatement Upload Request
  - Policy Reinstatement Status for Reason Verification
- Define the value for the **Online Record Process Limit** parameter in the **C1-DEFERUPLD** algorithm.
- Define the value for the **Policy Status after Processing Reinstatement Upload Request** parameter in the **C1-REN-PROC** algorithm.
- Assign the **C1-BCUUR** To Do type to a To Do role whose users must receive the To Do for approving a bill cycle update upload request.
- Assign the **C1-CRUUR** To Do type to a To Do role whose users must receive the To Do for approving a contract rider update upload request.
- Assign the **C1-HLDUR** To Do type to a To Do role whose users must receive the To Do for approving a hold upload request.
- Assign the **C1-REFUR** To Do type to a To Do role whose users must receive the To Do for approving a refund upload request.
- Assign the **C1-WOUR** To Do type to a To Do role whose users must receive the To Do for approving a write off upload request.
- Assign the **C1-BCUR** To Do type to a To Do role whose users must receive the To Do for approving a billable charge upload request.
- Assign the **C1-RPUR** To Do type to a To Do role whose users must receive the To Do for approving a reinstatement upload request.
- Create a To Do type named **C1-BGSRT** using the following information:
  - **Navigation Option** - c1upldrqTabMenu
  - **Sort Keys** - Define the following sort keys for the To Do type:

Sort Key	Use as Default	Sort Order
Upload Request ID	Yes	Descending

- **Drill Keys** - Define the following drill keys for the To Do type:

Table Name	Field Name
C1_UPLOAD_REQ	Upload Request ID

- Assign the **C1-BGSRT** To Do type to a To Do role whose users must receive the To Do for approving a bill group sorting upload request.
- Create a To Do type named **C1-BGDVP** using the following information:
  - **Navigation Option** - c1upldrqTabMenu

- **Sort Keys** - Define the following sort keys for the To Do type:

Sort Key	Use as Default	Sort Order
Upload Request ID	Yes	Descending

- **Drill Keys** - Define the following drill keys for the To Do type:

Table Name	Field Name
C1_UPLOAD_REQ	Upload Request ID

- Assign the **C1-BGDVP** To Do type to a To Do role whose users must receive the To Do for approving a bill group derivation and pricing parameters upload request.
- Set the batch control type of the **Upload Request Periodic Monitor (C1-UPLRQ)** batch to **Timed** and define the following attributes:
  - Time Interval
  - Timer Active
  - User ID
  - Batch Language
  - Email Address

## Algorithms Used in C1-BillCycleUpdateUplReq

The following table lists the algorithms which are used in the lifecycle of the **C1-BillCycleUpdateUplReq** business object:

Status	System Event	Algorithm	Algorithm Type	Description
Draft	Enter	C1-BCU-DERIV	C1-BCU-DERIV	<p>This algorithm reads the data in the <b>BO_DATA_AREA</b> column of the <b>C1_UPL_REQUEST</b> table and accordingly inserts the records in the <b>C1_UPLOAD_REQ_DTLS</b> table. In addition, the status of each record in the <b>C1_UPLOAD_REQ_DTLS</b> table is set to <b>Pending</b>.</p> <p>It derives the account ID using the account identifier type and account identifier combination whenever the account ID is not specified in the record. Once the account ID is derived, the corresponding record is updated in the <b>C1_UPLOAD_REQ_DTLS</b> table. If the system could not derive the account ID using the account identifier type and account identifier combination, the status of the record in the <b>C1_UPLOAD_REQ_DTLS</b> table is changed to <b>Invalid</b>.</p>

Status	System Event	Algorithm	Algorithm Type	Description
Validated	Enter	C1-BCU-VALID	C1-BCU-VALID	<p>This algorithm is invoked when the user clicks the <b>Validate</b> button. It validates the records which are in the <b>Pending</b> status. It checks whether the account ID and bill cycle specified in the record are valid. If the account ID and bill cycle are valid and if the bill cycle is associated with the division to which the account belongs, the status of the record in the <b>C1_UPLOAD_REQ_DTLS</b> table is changed to <b>Valid</b>.</p> <p>If the account ID is invalid, it derives the account ID using the account identifier type and account identifier combination and updates the record accordingly. In addition, it changes the status of the record in the <b>C1_UPLOAD_REQ_DTLS</b> table to <b>Valid</b>. However, if the system could not derive the account ID using the account identifier type and account identifier combination, or if the bill cycle is invalid, or if the bill cycle is not associated with the division to which the account belongs, the status of the record in the <b>C1_UPLOAD_REQ_DTLS</b> table is changed to <b>Invalid</b>.</p> <p>It also checks whether there are two or more records with the same account ID. If so, it validates and changes the status of one record to <b>Valid</b> and the status of the remaining records is changed to <b>Invalid</b>.</p>
Submitted	Monitor	F1-AT-RQJ	F1-GEN-BOMNJ	<p>This algorithm transitions the current status to the specified status. You can specify the status to which you want the business object to transition in the following parameters:</p> <ul style="list-style-type: none"> <li>• Next Status</li> <li>• Next Transition Condition</li> </ul> <p>At a time, you can specify value for either the <b>Next Status</b> or <b>Next Transition Condition</b> parameter. If you don't specify any value for these parameters, the system will transition the business object to the default next status specified in its lifecycle.</p>

Status	System Event	Algorithm	Algorithm Type	Description
Submitted	Enter	C1-UPLSUBENT	C1-UPLSUBENT	This algorithm is invoked when the user clicks the <b>Submit</b> button. It checks whether the approval is required for the upload request. If the approval is required for an upload request, the status of the upload request is changed to <b>Approval In Progress</b> . However, if the approval is not required for an upload request, the status of the upload request remains in the <b>Submitted</b> status.
Submitted	Enter	C1-DEFERUPLD	C1-DEFERUPLD	This algorithm is invoked when the status of the upload request is changed to <b>Submitted</b> or <b>Approved</b> . It checks whether the upload request must be processed in the real time (i.e. immediately) or in the deferred mode (i.e. in the background). If the number of valid records in the upload request does not exceed the online record process limit, the system changes the status of the upload request to <b>Processing</b> . However, if the number of valid records in the upload request exceeds the online record process limit, the system changes the status of the upload request to <b>Deferred Processing</b> .  It contains the following parameter: <ul style="list-style-type: none"> <li>• <b>Online Record Process Limit</b> <ul style="list-style-type: none"> <li>– Used to indicate the maximum number of valid records you can process in the real time (i.e. immediately).</li> </ul> </li> </ul>
Approval In Progress	Enter	C1-UPLAPPENT	C1-UPLAPPENT	This algorithm creates a To Do using the To Do type specified in the upload request type. The To Do is sent to the appropriate users with the To Do role which is specified in the upload request type. In addition, a log entry is added when a To Do is created using the To Do type.
Approval In Progress	Exit	C1-UPLAPPEXT	C1-UPLAPPEXT	This algorithm checks whether the approver is associated with the approval To Do role specified in the upload request type. If not, it does not allow the approver to approve or reject the upload request. In addition, it does not allow the submitter to approve or reject the upload request.

Status	System Event	Algorithm	Algorithm Type	Description
Approval In Progress	Exit	F1-TODOCOMPL	F1-TODOCOMPL	This algorithm completes To Do entries that are created for the business object when the business object exits the given status. It finds and completes all open To Do entries where the business object's primary key is defined as a drill key. However, if the <b>Exclude To Do Entries From Auto Completion</b> characteristic is defined for the business object, then the system does not automatically complete the respective To Do entry.
Approved	Enter	C1-DEFERUPLD	C1-DEFERUPLD	This algorithm is invoked when the status of the upload request is changed to <b>Submitted</b> or <b>Approved</b> . It checks whether the upload request must be processed in the real time (i.e. immediately) or in the deferred mode (i.e. in the background). If the number of valid records in the upload request does not exceed the online record process limit, the system changes the status of the upload request to <b>Processing</b> . However, if the number of valid records in the upload request exceeds the online record process limit, the system changes the status of the upload request to <b>Deferred Processing</b> .  It contains the following parameter: <ul style="list-style-type: none"> <li>• <b>Online Record Process Limit</b> <ul style="list-style-type: none"> <li>– Used to indicate the maximum number of valid records you can process in the real time (i.e. immediately).</li> </ul> </li> </ul>
Approved	Monitor	F1-AT-RQJ	F1-GEN-BOMNJ	This algorithm transitions the current status to the specified status. You can specify the status to which you want the business object to transition in the following parameters: <ul style="list-style-type: none"> <li>• Next Status</li> <li>• Next Transition Condition</li> </ul> At a time, you can specify value for either the <b>Next Status</b> or <b>Next Transition Condition</b> parameter. If you don't specify any value for these parameters, the system will transition the business object to the default next status specified in its lifecycle.

Status	System Event	Algorithm	Algorithm Type	Description
Deferred Processing	Monitor	F1-AT-RQJ	F1-GEN-BOMNJ	<p>This algorithm transitions the current status to the specified status. You can specify the status to which you want the business object to transition in the following parameters:</p> <ul style="list-style-type: none"> <li>• Next Status</li> <li>• Next Transition Condition</li> </ul> <p>At a time, you can specify value for either the <b>Next Status</b> or <b>Next Transition Condition</b> parameter. If you don't specify any value for these parameters, the system will transition the business object to the default next status specified in its lifecycle.</p>
Processing	Enter	C1-BCU-PROC	C1-BCU-PROC	<p>This algorithm fetches a list of records which are in the <b>Valid</b> status. For each valid record, the system reads the account ID and bill cycle, and updates the bill cycle information of the account using the entity business object defined in the upload request type. If the record is successfully processed, the status of the record is changed to <b>Processed</b>. However, if the record could not be processed successfully due to any reason, the status of the record is changed to <b>Error</b>. Finally, the status of the upload request is changed to <b>Processed</b>.</p>
Processing	Monitor	F1-AT-RQJ	F1-GEN-BOMNJ	<p>This algorithm transitions the current status to the specified status. You can specify the status to which you want the business object to transition in the following parameters:</p> <ul style="list-style-type: none"> <li>• Next Status</li> <li>• Next Transition Condition</li> </ul> <p>At a time, you can specify value for either the <b>Next Status</b> or <b>Next Transition Condition</b> parameter. If you don't specify any value for these parameters, the system will transition the business object to the default next status specified in its lifecycle.</p>

## Algorithms Used in C1-ContractRiderUpdateUplReq

The following table lists the algorithms which are used in the lifecycle of the **C1-ContractRiderUpdateUplReq** business object:

Status	System Event	Algorithm	Algorithm Type	Description
Draft	Enter	C1-CR-DERIV	C1-CR-DERIV	<p>This algorithm reads the data in the <b>BO_DATA_AREA</b> column of the <b>C1_UPL_REQUEST</b> table and accordingly inserts the records in the <b>C1_UPLOAD_REQ_DTLS</b> table. In addition, the status of each record in the <b>C1_UPLOAD_REQ_DTLS</b> table is set to <b>Pending</b>.</p> <p>It derives the account ID using the account identifier type and account identifier combination whenever the account ID is not specified in the record. Once the account ID is derived, the corresponding record is updated in the <b>C1_UPLOAD_REQ_DTLS</b> table. If the system could not derive the account ID using the account identifier type and account identifier combination, the status of the record in the <b>C1_UPLOAD_REQ_DTLS</b> table is changed to <b>Invalid</b>.</p>



Status	System Event	Algorithm	Algorithm Type	Description
Validated	Enter	C1-CR-VALID	C1-CR-VALID	<p>This algorithm is invoked when the user clicks the <b>Validate</b> button. It validates the records which are in the <b>Pending</b> status. It checks whether the account ID, contract ID, contract type, and bill factor specified in the record are valid. If the account ID, contract ID, contract type, and bill factor are valid, if the specified contract belongs to the account, and if the <b>Contract Rider Applicability</b> flag on the bill factor is set to <b>Y</b>, the status of the record in the <b>C1_UPLOAD_REQ_DTLS</b> table is changed to <b>Valid</b>.</p> <p>If the account ID is invalid, it derives the account ID using the account identifier type and account identifier combination and updates the record accordingly. In addition, it changes the status of the record in the <b>C1_UPLOAD_REQ_DTLS</b> table to <b>Valid</b>. However, if the system could not derive the account ID using the account identifier type and account identifier combination, or if the bill factor is invalid, or if the specified contract does not belong to the account, or if the <b>Contract Rider Applicability</b> flag on the bill factor is set to <b>N</b>, the status of the record in the <b>C1_UPLOAD_REQ_DTLS</b> table is changed to <b>Invalid</b>.</p> <p>It also checks whether there are two or more records with the same account ID and contract type combination. If so, it validates and changes the status of one record to <b>Valid</b> and the status of the remaining records is changed to <b>Invalid</b>.</p>
Submitted	Enter	C1-UPLSUBENT	C1-UPLSUBENT	<p>This algorithm is invoked when the user clicks the <b>Submit</b> button. It checks whether the approval is required for the upload request. If the approval is required for an upload request, the status of the upload request is changed to <b>Approval In Progress</b>. However, if the approval is not required for an upload request, the status of the upload request remains in the <b>Submitted</b> status.</p>

Status	System Event	Algorithm	Algorithm Type	Description
Submitted	Enter	C1-DEFERUPLD	C1-DEFERUPLD	<p>This algorithm is invoked when the status of the upload request is changed to <b>Submitted</b> or <b>Approved</b>. It checks whether the upload request must be processed in the real time (i.e. immediately) or in the deferred mode (i.e. in the background). If the number of valid records in the upload request does not exceed the online record process limit, the system changes the status of the upload request to <b>Processing</b>. However, if the number of valid records in the upload request exceeds the online record process limit, the system changes the status of the upload request to <b>Deferred Processing</b>.</p> <p>It contains the following parameter:</p> <ul style="list-style-type: none"> <li>• <b>Online Record Process Limit</b> <ul style="list-style-type: none"> <li>– Used to indicate the maximum number of valid records you can process in the real time (i.e. immediately).</li> </ul> </li> </ul>
Submitted	Monitor	F1-AT-RQJ	F1-GEN-BOMNJ	<p>This algorithm transitions the current status to the specified status. You can specify the status to which you want the business object to transition in the following parameters:</p> <ul style="list-style-type: none"> <li>• Next Status</li> <li>• Next Transition Condition</li> </ul> <p>At a time, you can specify value for either the <b>Next Status</b> or <b>Next Transition Condition</b> parameter. If you don't specify any value for these parameters, the system will transition the business object to the default next status specified in its lifecycle.</p>
Approval In Progress	Enter	C1-UPLAPPENT	C1-UPLAPPENT	<p>This algorithm creates a To Do using the To Do type specified in the upload request type. The To Do is sent to the appropriate users with the To Do role which is specified in the upload request type. In addition, a log entry is added when a To Do is created using the To Do type.</p>

Status	System Event	Algorithm	Algorithm Type	Description
Approval In Progress	Exit	C1-UPLAPPEXT	C1-UPLAPPEXT	This algorithm checks whether the approver is associated with the approval To Do role specified in the upload request type. If not, it does not allow the approver to approve or reject the upload request. In addition, it does not allow the submitter to approve or reject the upload request.
Approval In Progress	Exit	F1-TODOCOMPL	F1-TODOCOMPL	This algorithm completes To Do entries that are created for the business object when the business object exits the given status. It finds and completes all open To Do entries where the business object's primary key is defined as a drill key. However, if the <b>Exclude To Do Entries From Auto Completion</b> characteristic is defined for the business object, then the system does not automatically complete the respective To Do entry.
Approved	Enter	C1-DEFERUPLD	C1-DEFERUPLD	<p>This algorithm is invoked when the status of the upload request is changed to <b>Submitted</b> or <b>Approved</b>. It checks whether the upload request must be processed in the real time (i.e. immediately) or in the deferred mode (i.e. in the background). If the number of valid records in the upload request does not exceed the online record process limit, the system changes the status of the upload request to <b>Processing</b>. However, if the number of valid records in the upload request exceeds the online record process limit, the system changes the status of the upload request to <b>Deferred Processing</b>.</p> <p>It contains the following parameter:</p> <ul style="list-style-type: none"> <li>• <b>Online Record Process Limit</b> <ul style="list-style-type: none"> <li>– Used to indicate the maximum number of valid records you can process in the real time (i.e. immediately).</li> </ul> </li> </ul>

Status	System Event	Algorithm	Algorithm Type	Description
Approved	Monitor	F1-AT-RQJ	F1-GEN-BOMNJ	<p>This algorithm transitions the current status to the specified status. You can specify the status to which you want the business object to transition in the following parameters:</p> <ul style="list-style-type: none"> <li>• Next Status</li> <li>• Next Transition Condition</li> </ul> <p>At a time, you can specify value for either the <b>Next Status</b> or <b>Next Transition Condition</b> parameter. If you don't specify any value for these parameters, the system will transition the business object to the default next status specified in its lifecycle.</p>
Deferred Processing	Monitor	F1-AT-RQJ	F1-GEN-BOMNJ	<p>This algorithm transitions the current status to the specified status. You can specify the status to which you want the business object to transition in the following parameters:</p> <ul style="list-style-type: none"> <li>• Next Status</li> <li>• Next Transition Condition</li> </ul> <p>At a time, you can specify value for either the <b>Next Status</b> or <b>Next Transition Condition</b> parameter. If you don't specify any value for these parameters, the system will transition the business object to the default next status specified in its lifecycle.</p>

Status	System Event	Algorithm	Algorithm Type	Description
Processing	Enter	C1-CR-PROC	C1-CR-PROC	This algorithm fetches a list of records which are in the <b>Valid</b> status. For each valid record, the system reads the account ID and contract ID, and updates the contract rider information of the contract using the entity business object defined in the upload request type. If the contract ID is not specified in the record, then the system derives the active contract of the specified contract type on the account, and then updates the contract rider information of the contract. If the record is successfully processed, the status of the record is changed to <b>Processed</b> . However, if the record could not be processed successfully due to any reason, the status of the record is changed to <b>Error</b> . Finally, the status of the upload request is changed to <b>Processed</b> .
Processing	Monitor	F1-AT-RQJ	F1-GEN-BOMNJ	This algorithm transitions the current status to the specified status. You can specify the status to which you want the business object to transition in the following parameters: <ul style="list-style-type: none"> <li>• Next Status</li> <li>• Next Transition Condition</li> </ul> At a time, you can specify value for either the <b>Next Status</b> or <b>Next Transition Condition</b> parameter. If you don't specify any value for these parameters, the system will transition the business object to the default next status specified in its lifecycle.

## Algorithms Used in C1-HoldUploadRequest

The following table lists the algorithms which are used in the lifecycle of the **C1-HoldUploadRequest** business object:

Status	System Event	Algorithm	Algorithm Type	Description
Draft	Enter	C1-HLD-DERIV	C1-HLD-DERIV	<p>This algorithm reads the data in the <b>BO_DATA_AREA</b> column of the <b>C1_UPL_REQUEST</b> table and accordingly inserts the records in the <b>C1_UPLOAD_REQ_DTLS</b> table. In addition, the status of each record in the <b>C1_UPLOAD_REQ_DTLS</b> table is set to <b>Pending</b>.</p> <p>If the hold entity is <b>ACCT</b> and the entity ID is not specified in the record, it derives the account ID using the account identifier type and account identifier combination. Similarly, if the hold entity is <b>PERS</b> and the entity ID is not specified in the record, it derives the person ID using the person identifier type and person identifier combination. Once the account ID or person ID is derived, the corresponding record is updated in the <b>C1_UPLOAD_REQ_DTLS</b> table. If the system could not derive the account ID using the account identifier type and account identifier combination or if the system could not derive the person ID using the person identifier type and person identifier combination, the status of the record in the <b>C1_UPLOAD_REQ_DTLS</b> table is changed to <b>Invalid</b>.</p>

Status	System Event	Algorithm	Algorithm Type	Description
Validated	Enter	C1-HLD-VALID	C1-HLD-VALID	<p>This algorithm is invoked when the user clicks the <b>Validate</b> button. It validates the records which are in the <b>Pending</b> status. It checks whether the data provided for creating a hold request is valid. If the entity ID and hold data are valid, the status of the record in the <b>C1_UPLOAD_REQ_DTLS</b> table is changed to <b>Valid</b>.</p> <p>If the hold entity is <b>ACCT</b> and the entity ID is invalid, it derives the account ID using the account identifier type and account identifier combination and updates the record accordingly. Similarly, if the hold entity is <b>PERS</b> and the entity ID is invalid, it derives the person ID using the person identifier type and person identifier combination and updates the record accordingly. In addition, it changes the status of the record in the <b>C1_UPLOAD_REQ_DTLS</b> table to <b>Valid</b>. However, if the system could not derive the account ID using the account identifier type and account identifier combination, or if the system could not derive the person ID using the person identifier type and person identifier combination, or if the hold data is invalid, the status of the record in the <b>C1_UPLOAD_REQ_DTLS</b> table is changed to <b>Invalid</b>.</p>
Submitted	Enter	C1-UPLSUBENT	C1-UPLSUBENT	<p>This algorithm is invoked when the user clicks the <b>Submit</b> button. It checks whether the approval is required for the upload request. If the approval is required for an upload request, the status of the upload request is changed to <b>Approval In Progress</b>. However, if the approval is not required for an upload request, the status of the upload request remains in the <b>Submitted</b> status.</p>

Status	System Event	Algorithm	Algorithm Type	Description
Submitted	Enter	C1-DEFERUPLD	C1-DEFERUPLD	<p>This algorithm is invoked when the status of the upload request is changed to <b>Submitted</b> or <b>Approved</b>. It checks whether the upload request must be processed in the real time (i.e. immediately) or in the deferred mode (i.e. in the background). If the number of valid records in the upload request does not exceed the online record process limit, the system changes the status of the upload request to <b>Processing</b>. However, if the number of valid records in the upload request exceeds the online record process limit, the system changes the status of the upload request to <b>Deferred Processing</b>.</p> <p>It contains the following parameter:</p> <ul style="list-style-type: none"> <li>• <b>Online Record Process Limit</b> <ul style="list-style-type: none"> <li>– Used to indicate the maximum number of valid records you can process in the real time (i.e. immediately).</li> </ul> </li> </ul>
Submitted	Monitor	F1-AT-RQJ	F1-GEN-BOMNJ	<p>This algorithm transitions the current status to the specified status. You can specify the status to which you want the business object to transition in the following parameters:</p> <ul style="list-style-type: none"> <li>• Next Status</li> <li>• Next Transition Condition</li> </ul> <p>At a time, you can specify value for either the <b>Next Status</b> or <b>Next Transition Condition</b> parameter. If you don't specify any value for these parameters, the system will transition the business object to the default next status specified in its lifecycle.</p>
Approval In Progress	Enter	C1-UPLAPPENT	C1-UPLAPPENT	<p>This algorithm creates a To Do using the To Do type specified in the upload request type. The To Do is sent to the appropriate users with the To Do role which is specified in the upload request type. In addition, a log entry is added when a To Do is created using the To Do type.</p>



Status	System Event	Algorithm	Algorithm Type	Description
Approval In Progress	Exit	C1-UPLAPPEXT	C1-UPLAPPEXT	This algorithm checks whether the approver is associated with the approval To Do role specified in the upload request type. If not, it does not allow the approver to approve or reject the upload request. In addition, it does not allow the submitter to approve or reject the upload request.
Approval In Progress	Exit	F1-TODOCOMPL	F1-TODOCOMPL	This algorithm completes To Do entries that are created for the business object when the business object exits the given status. It finds and completes all open To Do entries where the business object's primary key is defined as a drill key. However, if the <b>Exclude To Do Entries From Auto Completion</b> characteristic is defined for the business object, then the system does not automatically complete the respective To Do entry.
Approved	Enter	C1-DEFERUPLD	C1-DEFERUPLD	<p>This algorithm is invoked when the status of the upload request is changed to <b>Submitted</b> or <b>Approved</b>. It checks whether the upload request must be processed in the real time (i.e. immediately) or in the deferred mode (i.e. in the background). If the number of valid records in the upload request does not exceed the online record process limit, the system changes the status of the upload request to <b>Processing</b>. However, if the number of valid records in the upload request exceeds the online record process limit, the system changes the status of the upload request to <b>Deferred Processing</b>.</p> <p>It contains the following parameter:</p> <ul style="list-style-type: none"> <li>• <b>Online Record Process Limit</b> <ul style="list-style-type: none"> <li>– Used to indicate the maximum number of valid records you can process in the real time (i.e. immediately).</li> </ul> </li> </ul>

Status	System Event	Algorithm	Algorithm Type	Description
Approved	Monitor	F1-AT-RQJ	F1-GEN-BOMNJ	<p>This algorithm transitions the current status to the specified status. You can specify the status to which you want the business object to transition in the following parameters:</p> <ul style="list-style-type: none"> <li>• Next Status</li> <li>• Next Transition Condition</li> </ul> <p>At a time, you can specify value for either the <b>Next Status</b> or <b>Next Transition Condition</b> parameter. If you don't specify any value for these parameters, the system will transition the business object to the default next status specified in its lifecycle.</p>
Deferred Processing	Monitor	F1-AT-RQJ	F1-GEN-BOMNJ	<p>This algorithm transitions the current status to the specified status. You can specify the status to which you want the business object to transition in the following parameters:</p> <ul style="list-style-type: none"> <li>• Next Status</li> <li>• Next Transition Condition</li> </ul> <p>At a time, you can specify value for either the <b>Next Status</b> or <b>Next Transition Condition</b> parameter. If you don't specify any value for these parameters, the system will transition the business object to the default next status specified in its lifecycle.</p>

Status	System Event	Algorithm	Algorithm Type	Description
Processing	Enter	C1-HLD-PROC	C1-HLD-PROC	<p>This algorithm fetches a list of records which are in the <b>Valid</b> status. For each valid record with a unique combination of the hold request type, start date, end date, hold reason, hold entity, hold entity start date, hold entity end date, comments, hold process details, and hold characteristic details, it creates one hold request using the entity business object defined in the upload request type. However, if there are multiple entity IDs with the same combination, all are added in the same hold request. The hold request is created in the <b>Draft</b> status and then transitioned to <b>Submit</b>.</p> <p>From the <b>Submit</b> status, the status of the hold request is either changed to <b>Approval In Progress</b> or <b>Active</b> depending on whether the <b>Approval Required</b> flag is set to <b>Yes</b>. If the number of bills of the entities which are kept on hold through the hold request does not exceed the defer processing count (defined in the hold request type), the status of the hold request is changed to <b>Active</b>. However, if the number of bills of the entities which are kept on hold through the hold request exceeds the defer processing count, the status of the hold request is changed to <b>Deferred Processing</b>. If the record is successfully processed, the status of the record is changed to <b>Processed</b>. However, if the record could not be processed successfully due to any reason, the status of the record is changed to <b>Error</b>. Finally, the status of the upload request is changed to <b>Processed</b>.</p>

Status	System Event	Algorithm	Algorithm Type	Description
Processing	Monitor	F1-AT-RQJ	F1-GEN-BOMNJ	<p>This algorithm transitions the current status to the specified status. You can specify the status to which you want the business object to transition in the following parameters:</p> <ul style="list-style-type: none"> <li>• Next Status</li> <li>• Next Transition Condition</li> </ul> <p>At a time, you can specify value for either the <b>Next Status</b> or <b>Next Transition Condition</b> parameter. If you don't specify any value for these parameters, the system will transition the business object to the default next status specified in its lifecycle.</p>

## Algorithms Used in C1-RefundUploadRequest

The following table lists the algorithms which are used in the lifecycle of the **C1-RefundUploadRequest** business object:

Status	System Event	Algorithm	Algorithm Type	Description
Validated	Enter	C1-RF-VALID	C1-RF-VALID	This algorithm validates the data uploaded in an upload request for creating refund requests before the request is submitted for processing.
Draft	Enter	C1-RF-DERIV	C1-RF-DERIV	This algorithm reads the <b>BO_DATA_AREA</b> in the request's primary table, derives additional data that is required for creating refund requests and inserts the records in <b>C1_UPLOAD_REQ_DTLS</b> table.
Submitted	Enter	C1-UPLSUBENT	C1-UPLSUBENT	This algorithm is invoked when the user clicks the <b>Submit</b> button. It checks whether the approval is required for the upload request. If the approval is required for an upload request, the status of the upload request is changed to <b>Approval In Progress</b> . However, if the approval is not required for an upload request, the status of the upload request remains in the <b>Submitted</b> status.

Status	System Event	Algorithm	Algorithm Type	Description
Submitted	Enter	C1-DEFERUPLD	C1-DEFERUPLD	<p>This algorithm is invoked when the status of the upload request is changed to <b>Submitted</b> or <b>Approved</b>. It checks whether the upload request must be processed in the real time (i.e. immediately) or in the deferred mode (i.e. in the background). If the number of valid records in the upload request does not exceed the online record process limit, the system changes the status of the upload request to <b>Processing</b>. However, if the number of valid records in the upload request exceeds the online record process limit, the system changes the status of the upload request to <b>Deferred Processing</b>.</p> <p>It contains the following parameter:</p> <ul style="list-style-type: none"> <li>• <b>Online Record Process Limit</b> <ul style="list-style-type: none"> <li>– Used to indicate the maximum number of valid records you can process in the real time (i.e. immediately).</li> </ul> </li> </ul>
Submitted	Monitor	F1-AT-RQJ	F1-GEN-BOMNJ	<p>This algorithm transitions the current status to the specified status. You can specify the status to which you want the business object to transition in the following parameters:</p> <ul style="list-style-type: none"> <li>• Next Status</li> <li>• Next Transition Condition</li> </ul> <p>At a time, you can specify value for either the <b>Next Status</b> or <b>Next Transition Condition</b> parameter. If you don't specify any value for these parameters, the system will transition the business object to the default next status specified in its lifecycle.</p>
Approval In Progress	Enter	C1-UPLAPPENT	C1-UPLAPPENT	<p>This algorithm creates a To Do using the To Do type specified in the upload request type. The To Do is sent to the appropriate users with the To Do role which is specified in the upload request type. In addition, a log entry is added when a To Do is created using the To Do type.</p>

Status	System Event	Algorithm	Algorithm Type	Description
Approval In Progress	Exit	C1-UPLAPPEXT	C1-UPLAPPEXT	This algorithm checks whether the approver is associated with the approval To Do role specified in the upload request type. If not, it does not allow the approver to approve or reject the upload request. In addition, it does not allow the submitter to approve or reject the upload request.
Approval In Progress	Exit	F1-TODOCOMPL	F1-TODOCOMPL	This algorithm completes To Do entries that are created for the business object when the business object exits the given status. It finds and completes all open To Do entries where the business object's primary key is defined as a drill key. However, if the <b>Exclude To Do Entries From Auto Completion</b> characteristic is defined for the business object, then the system does not automatically complete the respective To Do entry.
Approved	Enter	C1-DEFERUPLD	C1-DEFERUPLD	<p>This algorithm is invoked when the status of the upload request is changed to <b>Submitted</b> or <b>Approved</b>. It checks whether the upload request must be processed in the real time (i.e. immediately) or in the deferred mode (i.e. in the background). If the number of valid records in the upload request does not exceed the online record process limit, the system changes the status of the upload request to <b>Processing</b>. However, if the number of valid records in the upload request exceeds the online record process limit, the system changes the status of the upload request to <b>Deferred Processing</b>.</p> <p>It contains the following parameter:</p> <ul style="list-style-type: none"> <li>• <b>Online Record Process Limit</b> <ul style="list-style-type: none"> <li>– Used to indicate the maximum number of valid records you can process in the real time (i.e. immediately).</li> </ul> </li> </ul>

Status	System Event	Algorithm	Algorithm Type	Description
Approved	Monitor	F1-AT-RQJ	F1-GEN-BOMNJ	<p>This algorithm transitions the current status to the specified status. You can specify the status to which you want the business object to transition in the following parameters:</p> <ul style="list-style-type: none"> <li>• Next Status</li> <li>• Next Transition Condition</li> </ul> <p>At a time, you can specify value for either the <b>Next Status</b> or <b>Next Transition Condition</b> parameter. If you don't specify any value for these parameters, the system will transition the business object to the default next status specified in its lifecycle.</p>
Deferred Processing	Monitor	F1-AT-RQJ	F1-GEN-BOMNJ	<p>This algorithm transitions the current status to the specified status. You can specify the status to which you want the business object to transition in the following parameters:</p> <ul style="list-style-type: none"> <li>• Next Status</li> <li>• Next Transition Condition</li> </ul> <p>At a time, you can specify value for either the <b>Next Status</b> or <b>Next Transition Condition</b> parameter. If you don't specify any value for these parameters, the system will transition the business object to the default next status specified in its lifecycle.</p>
Processing	Enter	C1-RF-PROC	C1-RF-PROC	<p>This algorithm fetches the list of records that are in <b>Valid</b> status for a given request ID and invokes the entity business object for creating the refund requests. If successfully processed, then the record status will be updated to <b>Processed</b>, otherwise the record status will be updated to <b>Error</b> and error details will be logged in the exception table.</p>

Status	System Event	Algorithm	Algorithm Type	Description
Processing	Monitor	F1-AT-RQJ	F1-GEN-BOMNJ	<p>This algorithm transitions the current status to the specified status. You can specify the status to which you want the business object to transition in the following parameters:</p> <ul style="list-style-type: none"> <li>• Next Status</li> <li>• Next Transition Condition</li> </ul> <p>At a time, you can specify value for either the <b>Next Status</b> or <b>Next Transition Condition</b> parameter. If you don't specify any value for these parameters, the system will transition the business object to the default next status specified in its lifecycle.</p>

## Algorithms Used in C1-WriteOffUploadRequest

The following table lists the algorithms which are used in the lifecycle of the **C1-WriteOffUploadRequest** business object:

Status	System Event	Algorithm	Algorithm Type	Description
Draft	Enter	C1-WO-DERIV	C1-WO-DERIV	This algorithm reads the <b>BO_DATA_AREA</b> in the request's primary table, derives additional data that is required for creating write off requests and inserts the records in <b>C1_UPLOAD_REQ_DTLS</b> table.
Submitted	Enter	C1-UPLSUBENT	C1-UPLSUBENT	This algorithm is invoked when the user clicks the <b>Submit</b> button. It checks whether the approval is required for the upload request. If the approval is required for an upload request, the status of the upload request is changed to <b>Approval In Progress</b> . However, if the approval is not required for an upload request, the status of the upload request remains in the <b>Submitted</b> status.



Status	System Event	Algorithm	Algorithm Type	Description
Submitted	Enter	C1-DEFERUPLD	C1-DEFERUPLD	<p>This algorithm is invoked when the status of the upload request is changed to <b>Submitted</b> or <b>Approved</b>. It checks whether the upload request must be processed in the real time (i.e. immediately) or in the deferred mode (i.e. in the background). If the number of valid records in the upload request does not exceed the online record process limit, the system changes the status of the upload request to <b>Processing</b>. However, if the number of valid records in the upload request exceeds the online record process limit, the system changes the status of the upload request to <b>Deferred Processing</b>.</p> <p>It contains the following parameter:</p> <ul style="list-style-type: none"> <li>• <b>Online Record Process Limit</b> <ul style="list-style-type: none"> <li>– Used to indicate the maximum number of valid records you can process in the real time (i.e. immediately).</li> </ul> </li> </ul>
Submitted	Monitor	F1-AT-RQJ	F1-GEN-BOMNJ	<p>This algorithm transitions the current status to the specified status. You can specify the status to which you want the business object to transition in the following parameters:</p> <ul style="list-style-type: none"> <li>• Next Status</li> <li>• Next Transition Condition</li> </ul> <p>At a time, you can specify value for either the <b>Next Status</b> or <b>Next Transition Condition</b> parameter. If you don't specify any value for these parameters, the system will transition the business object to the default next status specified in its lifecycle.</p>
Approval In Progress	Enter	C1-UPLAPPENT	C1-UPLAPPENT	<p>This algorithm creates a To Do using the To Do type specified in the upload request type. The To Do is sent to the appropriate users with the To Do role which is specified in the upload request type. In addition, a log entry is added when a To Do is created using the To Do type.</p>

Status	System Event	Algorithm	Algorithm Type	Description
Approval In Progress	Exit	C1-UPLAPPEXT	C1-UPLAPPEXT	This algorithm checks whether the approver is associated with the approval To Do role specified in the upload request type. If not, it does not allow the approver to approve or reject the upload request. In addition, it does not allow the submitter to approve or reject the upload request.
Approval In Progress	Exit	F1-TODOCOMPL	F1-TODOCOMPL	This algorithm completes To Do entries that are created for the business object when the business object exits the given status. It finds and completes all open To Do entries where the business object's primary key is defined as a drill key. However, if the <b>Exclude To Do Entries From Auto Completion</b> characteristic is defined for the business object, then the system does not automatically complete the respective To Do entry.
Approved	Enter	C1-DEFERUPLD	C1-DEFERUPLD	<p>This algorithm is invoked when the status of the upload request is changed to <b>Submitted</b> or <b>Approved</b>. It checks whether the upload request must be processed in the real time (i.e. immediately) or in the deferred mode (i.e. in the background). If the number of valid records in the upload request does not exceed the online record process limit, the system changes the status of the upload request to <b>Processing</b>. However, if the number of valid records in the upload request exceeds the online record process limit, the system changes the status of the upload request to <b>Deferred Processing</b>.</p> <p>It contains the following parameter:</p> <ul style="list-style-type: none"> <li>• <b>Online Record Process Limit</b> <ul style="list-style-type: none"> <li>– Used to indicate the maximum number of valid records you can process in the real time (i.e. immediately).</li> </ul> </li> </ul>

Status	System Event	Algorithm	Algorithm Type	Description
Approved	Monitor	F1-AT-RQJ	F1-GEN-BOMNJ	<p>This algorithm transitions the current status to the specified status. You can specify the status to which you want the business object to transition in the following parameters:</p> <ul style="list-style-type: none"> <li>• Next Status</li> <li>• Next Transition Condition</li> </ul> <p>At a time, you can specify value for either the <b>Next Status</b> or <b>Next Transition Condition</b> parameter. If you don't specify any value for these parameters, the system will transition the business object to the default next status specified in its lifecycle.</p>
Deferred Processing	Monitor	F1-AT-RQJ	F1-GEN-BOMNJ	<p>This algorithm transitions the current status to the specified status. You can specify the status to which you want the business object to transition in the following parameters:</p> <ul style="list-style-type: none"> <li>• Next Status</li> <li>• Next Transition Condition</li> </ul> <p>At a time, you can specify value for either the <b>Next Status</b> or <b>Next Transition Condition</b> parameter. If you don't specify any value for these parameters, the system will transition the business object to the default next status specified in its lifecycle.</p>
Processing	Enter	C1-WO-PROC	C1-WO-PROC	<p>This algorithm fetches the list of records that are in <b>Valid</b> status for a given request ID and invokes the entity business object for creating the write off requests. If successfully processed, then the record status will be updated to <b>Processed</b>, otherwise the record status will be updated to <b>Error</b> and error details will be logged in the exception table.</p>

Status	System Event	Algorithm	Algorithm Type	Description
Processing	Monitor	F1-AT-RQJ	F1-GEN-BOMNJ	<p>This algorithm transitions the current status to the specified status. You can specify the status to which you want the business object to transition in the following parameters:</p> <ul style="list-style-type: none"> <li>• Next Status</li> <li>• Next Transition Condition</li> </ul> <p>At a time, you can specify value for either the <b>Next Status</b> or <b>Next Transition Condition</b> parameter. If you don't specify any value for these parameters, the system will transition the business object to the default next status specified in its lifecycle.</p>

## Algorithms Used in C1-BillableChargeUploadRequest

The following table lists the algorithms which are used in the lifecycle of the **C1-BillableChargeUploadRequest** business object:

Status	System Event	Algorithm	Algorithm Type	Description
Draft	Enter	C1-CRTUPLDTL	C1-CRTUPLDTL	<p>This algorithm reads the data in the <b>BO_DATA_AREA</b> column of the <b>C1_UPL_REQUEST</b> table and accordingly inserts the records in the <b>C1_UPLOAD_REQ_DTLS</b> table. In addition, the status of each record in the <b>C1_UPLOAD_REQ_DTLS</b> table is set to <b>Pending</b>.</p>
Draft	Enter	C1-BC-DERIV	C1-BC-DERIV	<p>This algorithm reads the <b>BO_DATA_AREA</b> in the request's primary table, derives additional data that is required for creating billable charges and inserts the records in <b>C1_UPLOAD_REQ_DTLS</b> table.</p>
Validated	Enter	C1-BC-VALID	C1-BC-VALID	<p>This algorithm validates the data upload in an upload request for creating billable charges before the request is submitted for processing.</p>

Status	System Event	Algorithm	Algorithm Type	Description
Submitted	Enter	C1-UPLSUBENT	C1-UPLSUBENT	This algorithm is invoked when the user clicks the <b>Submit</b> button. It checks whether the approval is required for the upload request. If the approval is required for an upload request, the status of the upload request is changed to <b>Approval In Progress</b> . However, if the approval is not required for an upload request, the status of the upload request remains in the <b>Submitted</b> status.
Submitted	Enter	C1-DEFERUPLD	C1-DEFERUPLD	This algorithm is invoked when the status of the upload request is changed to <b>Submitted</b> or <b>Approved</b> . It checks whether the upload request must be processed in the real time (i.e. immediately) or in the deferred mode (i.e. in the background). If the number of valid records in the upload request does not exceed the online record process limit, the system changes the status of the upload request to <b>Processing</b> . However, if the number of valid records in the upload request exceeds the online record process limit, the system changes the status of the upload request to <b>Deferred Processing</b> .  It contains the following parameter: <ul style="list-style-type: none"> <li>• <b>Online Record Process Limit</b> <ul style="list-style-type: none"> <li>– Used to indicate the maximum number of valid records you can process in the real time (i.e. immediately).</li> </ul> </li> </ul>
Submitted	Monitor	F1-AT-RQJ	F1-GEN-BOMNJ	This algorithm transitions the current status to the specified status. You can specify the status to which you want the business object to transition in the following parameters: <ul style="list-style-type: none"> <li>• Next Status</li> <li>• Next Transition Condition</li> </ul> At a time, you can specify value for either the <b>Next Status</b> or <b>Next Transition Condition</b> parameter. If you don't specify any value for these parameters, the system will transition the business object to the default next status specified in its lifecycle.

Status	System Event	Algorithm	Algorithm Type	Description
Approval In Progress	Enter	C1-UPLAPPENT	C1-UPLAPPENT	This algorithm creates a To Do using the To Do type specified in the upload request type. The To Do is sent to the appropriate users with the To Do role which is specified in the upload request type. In addition, a log entry is added when a To Do is created using the To Do type.
Approval In Progress	Exit	C1-UPLAPPEXT	C1-UPLAPPEXT	This algorithm checks whether the approver is associated with the approval To Do role specified in the upload request type. If not, it does not allow the approver to approve or reject the upload request. In addition, it does not allow the submitter to approve or reject the upload request.
Approval In Progress	Exit	F1-TODOCOMPL	F1-TODOCOMPL	This algorithm completes To Do entries that are created for the business object when the business object exits the given status. It finds and completes all open To Do entries where the business object's primary key is defined as a drill key. However, if the <b>Exclude To Do Entries From Auto Completion</b> characteristic is defined for the business object, then the system does not automatically complete the respective To Do entry.

Status	System Event	Algorithm	Algorithm Type	Description
Approved	Enter	C1-DEFERUPLD	C1-DEFERUPLD	<p>This algorithm is invoked when the status of the upload request is changed to <b>Submitted</b> or <b>Approved</b>. It checks whether the upload request must be processed in the real time (i.e. immediately) or in the deferred mode (i.e. in the background). If the number of valid records in the upload request does not exceed the online record process limit, the system changes the status of the upload request to <b>Processing</b>. However, if the number of valid records in the upload request exceeds the online record process limit, the system changes the status of the upload request to <b>Deferred Processing</b>.</p> <p>It contains the following parameter:</p> <ul style="list-style-type: none"> <li>• <b>Online Record Process Limit</b> <ul style="list-style-type: none"> <li>– Used to indicate the maximum number of valid records you can process in the real time (i.e. immediately).</li> </ul> </li> </ul>
Approved	Monitor	F1-AT-RQJ	F1-GEN-BOMNJ	<p>This algorithm transitions the current status to the specified status. You can specify the status to which you want the business object to transition in the following parameters:</p> <ul style="list-style-type: none"> <li>• Next Status</li> <li>• Next Transition Condition</li> </ul> <p>At a time, you can specify value for either the <b>Next Status</b> or <b>Next Transition Condition</b> parameter. If you don't specify any value for these parameters, the system will transition the business object to the default next status specified in its lifecycle.</p>

Status	System Event	Algorithm	Algorithm Type	Description
Deferred Processing	Monitor	F1-AT-RQJ	F1-GEN-BOMNJ	<p>This algorithm transitions the current status to the specified status. You can specify the status to which you want the business object to transition in the following parameters:</p> <ul style="list-style-type: none"> <li>• Next Status</li> <li>• Next Transition Condition</li> </ul> <p>At a time, you can specify value for either the <b>Next Status</b> or <b>Next Transition Condition</b> parameter. If you don't specify any value for these parameters, the system will transition the business object to the default next status specified in its lifecycle.</p>
Processing	Enter	C1-BC-PROC	C1-BC-PROC	<p>This algorithm fetches the list of records that are in <b>Valid</b> status for a given request ID and invokes the entity business object for creating billable charge on the contract. If successfully created, then the record status will be updated to <b>Processed</b>, otherwise the record status will be updated to <b>Error</b> and error details will be logged in the exception table.</p>
Processing	Monitor	F1-AT-RQJ	F1-GEN-BOMNJ	<p>This algorithm transitions the current status to the specified status. You can specify the status to which you want the business object to transition in the following parameters:</p> <ul style="list-style-type: none"> <li>• Next Status</li> <li>• Next Transition Condition</li> </ul> <p>At a time, you can specify value for either the <b>Next Status</b> or <b>Next Transition Condition</b> parameter. If you don't specify any value for these parameters, the system will transition the business object to the default next status specified in its lifecycle.</p>

## Algorithms Used in C1-ReinstatementUploadRequest

The following table lists the algorithms which are used in the lifecycle of the **C1-ReinstatementUploadRequest** business object:



Status	System Event	Algorithm	Algorithm Type	Description
Draft	Enter	C1-CRTUPLDTL	C1-CRTUPLDTL	This algorithm reads the data in the <b>BO_DATA_AREA</b> column of the <b>C1_UPL_REQUEST</b> table and accordingly inserts the records in the <b>C1_UPLOAD_REQ_DTLS</b> table. In addition, the status of each record in the <b>C1_UPLOAD_REQ_DTLS</b> table is set to <b>Pending</b> .
Draft	Enter	C1-REN-DERIV	C1-REN-DERIV	This algorithm reads the data in the <b>BO_DATA_AREA</b> column of the <b>C1_UPLOAD_REQ_DTLS</b> table and then derives the policy ID using the source system and policy number combination whenever the policy ID is not specified in the record. Once the policy ID is derived, the corresponding record is updated in the <b>C1_UPLOAD_REQ_DTLS</b> table. If the system could not derive the policy ID using the source system and policy number combination, the status of the record in the <b>C1_UPLOAD_REQ_DTLS</b> table is changed to <b>Invalid</b> .

Status	System Event	Algorithm	Algorithm Type	Description
Validated	Enter	C1-REN-VALID	C1-REN-VALID	<p>This algorithm is invoked when the user clicks the <b>Validate</b> button. It validates the records which are in the <b>Pending</b> status. It checks whether the policy ID and reinstatement reason specified in the record is valid. If the policy ID and reinstatement reason are valid, the status of the record in the <b>C1_UPLOAD_REQ_DTLS</b> table is changed to <b>Valid</b>.</p> <p>If the policy ID is invalid, it derives the policy ID using the source system and policy number combination and updates the record accordingly. In addition, it changes the status of the record in the <b>C1_UPLOAD_REQ_DTLS</b> table to <b>Valid</b>. However, if the system could not derive the policy ID using the source system and policy number combination, or if the reinstatement reason is invalid, the status of the record in the <b>C1_UPLOAD_REQ_DTLS</b> table is changed to <b>Invalid</b>.</p> <p>It also checks whether there are two or more policies with the same policy ID. If so, it validates and changes the status of one record to <b>Valid</b> and the status of the remaining records is changed to <b>Invalid</b>. It contains the following parameters:</p> <ul style="list-style-type: none"> <li>• <b>Policy Status after Processing Reinstatement Upload Request</b> – Used to specify the status to which you want to transition the policy when the reinstatement upload request is processed.</li> <li>• <b>Policy Reinstatement Status for Reason Verification</b> – Used to validate the reinstatement reason. The reason should be a valid reason for the specified status.</li> </ul>

Status	System Event	Algorithm	Algorithm Type	Description
Submitted	Monitor	F1-AT-RQJ	F1-GEN-BOMNJ	<p>This algorithm transitions the current status to the specified status. You can specify the status to which you want the business object to transition in the following parameters:</p> <ul style="list-style-type: none"> <li>• Next Status</li> <li>• Next Transition Condition</li> </ul> <p>At a time, you can specify value for either the <b>Next Status</b> or <b>Next Transition Condition</b> parameter. If you don't specify any value for these parameters, the system will transition the business object to the default next status specified in its lifecycle.</p>
Submitted	Enter	C1-UPLSUBENT	C1-UPLSUBENT	<p>This algorithm is invoked when the user clicks the <b>Submit</b> button. It checks whether the approval is required for the upload request. If the approval is required for an upload request, the status of the upload request is changed to <b>Approval In Progress</b>. However, if the approval is not required for an upload request, the status of the upload request remains in the <b>Submitted</b> status.</p>
Submitted	Enter	C1-DEFERUPLD	C1-DEFERUPLD	<p>This algorithm is invoked when the status of the upload request is changed to <b>Submitted</b> or <b>Approved</b>. It checks whether the upload request must be processed in the real time (i.e. immediately) or in the deferred mode (i.e. in the background). If the number of valid records in the upload request does not exceed the online record process limit, the system changes the status of the upload request to <b>Processing</b>. However, if the number of valid records in the upload request exceeds the online record process limit, the system changes the status of the upload request to <b>Deferred Processing</b>.</p> <p>It contains the following parameter:</p> <ul style="list-style-type: none"> <li>• <b>Online Record Process Limit</b> – Used to indicate the maximum number of valid records you can process in the real time (i.e. immediately).</li> </ul>
Approval In Progress	Enter	C1-UPLAPPENT	C1-UPLAPPENT	<p>This algorithm creates a To Do using the To Do type specified in the upload request type. The To Do is sent to the appropriate users with the To Do role which is specified in the upload request type. In addition, a log entry is added when a To Do is created using the To Do type.</p>

Status	System Event	Algorithm	Algorithm Type	Description
Approval In Progress	Exit	C1-UPLAPPEXT	C1-UPLAPPEXT	This algorithm checks whether the approver is associated with the approval To Do role specified in the upload request type. If not, it does not allow the approver to approve or reject the upload request. In addition, it does not allow the submitter to approve or reject the upload request.
Approval In Progress	Exit	F1-TODOCOMPL	F1-TODOCOMPL	This algorithm completes To Do entries that are created for the business object when the business object exits the given status. It finds and completes all open To Do entries where the business object's primary key is defined as a drill key. However, if the <b>Exclude To Do Entries From Auto Completion</b> characteristic is defined for the business object, then the system does not automatically complete the respective To Do entry.
Approved	Enter	C1-DEFERUPLD	C1-DEFERUPLD	<p>This algorithm is invoked when the status of the upload request is changed to <b>Submitted</b> or <b>Approved</b>. It checks whether the upload request must be processed in the real time (i.e. immediately) or in the deferred mode (i.e. in the background). If the number of valid records in the upload request does not exceed the online record process limit, the system changes the status of the upload request to <b>Processing</b>. However, if the number of valid records in the upload request exceeds the online record process limit, the system changes the status of the upload request to <b>Deferred Processing</b>.</p> <p>It contains the following parameter:</p> <ul style="list-style-type: none"> <li>• <b>Online Record Process Limit</b> – Used to indicate the maximum number of valid records you can process in the real time (i.e. immediately).</li> </ul>

Status	System Event	Algorithm	Algorithm Type	Description
Approved	Monitor	F1-AT-RQJ	F1-GEN-BOMNJ	<p>This algorithm transitions the current status to the specified status. You can specify the status to which you want the business object to transition in the following parameters:</p> <ul style="list-style-type: none"> <li>• Next Status</li> <li>• Next Transition Condition</li> </ul> <p>At a time, you can specify value for either the <b>Next Status</b> or <b>Next Transition Condition</b> parameter. If you don't specify any value for these parameters, the system will transition the business object to the default next status specified in its lifecycle.</p>
Deferred Processing	Monitor	F1-AT-RQJ	F1-GEN-BOMNJ	<p>This algorithm transitions the current status to the specified status. You can specify the status to which you want the business object to transition in the following parameters:</p> <ul style="list-style-type: none"> <li>• Next Status</li> <li>• Next Transition Condition</li> </ul> <p>At a time, you can specify value for either the <b>Next Status</b> or <b>Next Transition Condition</b> parameter. If you don't specify any value for these parameters, the system will transition the business object to the default next status specified in its lifecycle.</p>
Processing	Monitor	F1-AT-RQJ	F1-GEN-BOMNJ	<p>This algorithm transitions the current status to the specified status. You can specify the status to which you want the business object to transition in the following parameters:</p> <ul style="list-style-type: none"> <li>• Next Status</li> <li>• Next Transition Condition</li> </ul> <p>At a time, you can specify value for either the <b>Next Status</b> or <b>Next Transition Condition</b> parameter. If you don't specify any value for these parameters, the system will transition the business object to the default next status specified in its lifecycle.</p>

Status	System Event	Algorithm	Algorithm Type	Description
Processing	Enter	C1-REN-PROC	C1-REN-PROC	<p>This algorithm fetches a list of records which are in the <b>Valid</b> status. For each valid record, the system reads the policy ID and reinstatement reason, and reinstates the policy using the entity business object defined in the upload request type. On reinstating the policy, the status of the policy is changed as mentioned in this algorithm. If the record is successfully processed, the status of the record is changed to <b>Processed</b>. However, if the record could not be processed successfully due to any reason, the status of the record is changed to <b>Error</b>. Finally, the status of the upload request is changed to <b>Processed</b>.</p> <p>It contains the following parameter:</p> <ul style="list-style-type: none"> <li>• <b>Policy Status after Processing Reinstatement Upload Request</b> - Used to specify the status to which you want to transition the policy when the reinstatement upload request is processed.</li> </ul>

## Algorithms Used in C1-BillGrpSortUploadRequest

The following table lists the algorithms which are used in the lifecycle of the **C1-BillGrpSortUploadRequest** business object:

Status	System Event	Algorithm	Algorithm Type	Description
Draft	Enter	C1-BLSRTUPLD	C1-BLSRTUPLD	Refer to <a href="#">C1-BLSRTUPLD</a> on page 1615.
Draft	Enter	C1-BLSRTDERV	C1-BLSRTDERV	Refer to <a href="#">C1-BLSRTDERV</a> on page 1615.
Validated	Enter	C1-BLSRTVALD	C1-BLSRTVALD	Refer to <a href="#">C1-BLSRTVALD</a> on page 1615.
Canceled	—	—	—	—
Submitted	Monitor	F1-AT-RQJ	F1-GEN-BOMNJ	Refer to <a href="#">F1-AT-RQJ</a> on page 1257.
Submitted	Enter	C1-UPLSUBENT	C1-UPLSUBENT	Refer to <a href="#">C1-UPLSUBENT</a> on page 1616.
Submitted	Enter	C1-DEFERUPLD	C1-DEFERUPLD	Refer to <a href="#">C1-DEFERUPLD</a> on page 1616.
Approval In Progress	Enter	C1-UPLAPPENT	C1-UPLAPPENT	Refer to <a href="#">C1-UPLAPPENT</a> on page 1616.
Approval In Progress	Exit	C1-UPLAPPEXT	C1-UPLAPPEXT	Refer to <a href="#">C1-UPLAPPEXT</a> on page 1616.

Status	System Event	Algorithm	Algorithm Type	Description
Approval In Progress	Exit	F1-TODOCOMPL	F1-TODOCOMPL	Refer to <a href="#">F1-TODOCOMPL</a> on page 1256.
Approved	Monitor	F1-AT-RQJ	F1-GEN-BOMNJ	Refer to <a href="#">F1-AT-RQJ</a> on page 1257.
Approved	Enter	C1-DEFERUPLD	C1-DEFERUPLD	Refer to <a href="#">C1-DEFERUPLD</a> on page 1616.
Rejected	—	—	—	—
Deferred Processing	Monitor	F1-AT-RQJ	F1-GEN-BOMNJ	Refer to <a href="#">F1-AT-RQJ</a> on page 1257.
Processing	Monitor	F1-AT-RQJ	F1-GEN-BOMNJ	Refer to <a href="#">F1-AT-RQJ</a> on page 1257.
Processing	Enter	C1-BLSRTPROC	C1-BLSRTPROC	Refer to <a href="#">C1-BLSRTPROC</a> on page 1617.
Processed	—	—	—	—

## C1-BLSRTUPLD

This algorithm reads the data in the **BO\_DATA\_AREA** column of the **C1\_UPL\_REQUEST** table and accordingly inserts the records in the **C1\_UPLOAD\_REQ\_DTLS** table. In addition, the status of each record in the **C1\_UPLOAD\_REQ\_DTLS** table is set to **Pending**.

## C1-BLSRTDERV

This algorithm reads the data in the **BO\_DATA\_AREA** column of the **C1\_UPLOAD\_REQ\_DTLS** table and then derives the bill group (person) ID using the bill group (person) identifier type and bill group (person) identifier combination whenever the bill group ID is not specified in the record. Once the bill group ID is derived, the corresponding record is updated in the **C1\_UPLOAD\_REQ\_DTLS** table. If the system could not derive the bill group ID using the bill group identifier type and bill group identifier combination, the status of the record in the **C1\_UPLOAD\_REQ\_DTLS** table is changed to **Invalid**.

## C1-BLSRTVALD

This algorithm is invoked when the user clicks the **Validate** button. It validates the records which are in the **Pending** status. It checks the following:

- The parent customer's person type is set to **Parent Customer** in the system.
- All mandatory information is available in the bill group sort record.
- The end date is not earlier than the start date and the start date is not later than the end date.
- Either the bill group (person) identifier type and bill group (person) identifier or the bill group (person) ID is available in the bill group sort record.
- The bill group identifier type is available when the bill group identifier is specified and vice versa.
- A bill group with the specified bill group ID exists in the system.
- The bill group is the child person of the parent customer.
- The bill group's person type is set to **Bill Group** in the system.
- The relationship between the bill group and parent customer is effective on the system date.
- The bill group is related to the parent customer using a relationship type which is specified in the **Person Relationship Type** option type of the **C1-ASOBLNG** feature configuration.
- A duplicate record with the bill group ID and sort ID combination does not exist in the **C1\_BILL\_LVL** table.

- A duplicate record with the bill group ID and sort ID combination does not exist in the **C1\_UPLOAD\_REQ\_DTLS** table.

If the above mentioned validations are successful, the status of the record in the **C1\_UPLOAD\_REQ\_DTLS** table is changed to **Valid**. However, if any of the above validation fails, the status of the record in the **C1\_UPLOAD\_REQ\_DTLS** table is changed to **Invalid**.

## F1-AT-RQJ

This algorithm transitions the current status of the business object to the specified status. It contains the following parameters:

- **Next Status** – Used when you want to override the default next status specified in the lifecycle.
- **Next Transition Condition** – Used when you want to override the default next transition condition specified in the lifecycle.

At a time, you can specify value for either the **Next Status** or **Next Transition Condition** parameter. If you don't specify any value for these parameters, the system will transition the business object to the default next status specified in its lifecycle.

## C1-UPLSUBENT

This algorithm is invoked when the user clicks the **Submit** button. It checks whether the approval is required for the upload request. If the approval is required for an upload request, the status of the upload request is changed to **Approval In Progress**. However, if the approval is not required for an upload request, the status of the upload request remains in the **Submitted** status.

## C1-DEFERUPLD

This algorithm is invoked when the status of the upload request is changed to **Submitted** or **Approved**. It checks whether the upload request must be processed in the real time (i.e. immediately) or in the deferred mode (i.e. in the background). If the number of valid records in the upload request does not exceed the online record process limit, the system changes the status of the upload request to **Processing**. However, if the number of valid records in the upload request exceeds the online record process limit, the system changes the status of the upload request to **Deferred Processing**.

It contains the following parameter:

- **Online Record Process Limit** – Used to indicate the maximum number of valid records you can process in the real time (i.e. immediately).

## C1-UPLAPPENT

This algorithm creates a To Do using the To Do type specified in the upload request type. The To Do is sent to the appropriate users with the To Do role which is specified in the upload request type. In addition, a log entry is added when a To Do is created using the To Do type.

## C1-UPLAPPEXT

This algorithm checks whether the approver is associated with the approval To Do role specified in the upload request type. If not, it does not allow the approver to approve or reject the upload request. In addition, it does not allow the submitter to approve or reject the upload request.

## F1-TODOCOMPL

This algorithm completes To Do entries that are created for the business object when the business object exits the given status. It finds and completes all open To Do entries where the business object's primary key is defined as a drill key. However, if the **Exclude To Do Entries From Auto Completion** characteristic is set to **Y** for the business object, the system does not automatically complete the respective To Do entry.



## C1-BLSRTPROC

This algorithm fetches a list of records which are in the **Valid** status. For each valid record with a unique combination of the bill group (person) ID and sort ID, it creates one bill group sort record using the entity business object defined in the upload request type. If the record is successfully processed, the status of the record is changed to **Processed**. However, if the record could not be processed successfully due to any reason, the status of the record is changed to **Error**. Finally, the status of the upload request is changed to **Processed**.

## Algorithms Used in C1-BillLevelUploadRequest

The following table lists the algorithms which are used in the lifecycle of the **C1-BillLevelUploadRequest** business object:

Status	System Event	Algorithm	Algorithm Type	Description
Draft	Enter	C1-BLVUPLDTL	C1-BLVUPLDTL	Refer to <a href="#">C1-BLVUPLDTL</a> on page 1618.
Draft	Enter	C1-BLVLDERIV	C1-BLVLDERIV	Refer to <a href="#">C1-BLVLDERIV</a> on page 1618.
Validated	Enter	C1-BLVLVALID	C1-BLVLVALID	Refer to <a href="#">C1-BLVLVALID</a> on page 1618.
Canceled	—	—	—	—
Submitted	Monitor	F1-AT-RQJ	F1-GEN-BOMNJ	Refer to <a href="#">F1-AT-RQJ</a> on page 1257.
Submitted	Enter	C1-UPLSUBENT	C1-UPLSUBENT	Refer to <a href="#">C1-UPLSUBENT</a> on page 1616.
Submitted	Enter	C1-DEFERUPLD	C1-DEFERUPLD	Refer to <a href="#">C1-DEFERUPLD</a> on page 1616.
Approval Progress	In Enter	C1-UPLAPPENT	C1-UPLAPPENT	Refer to <a href="#">C1-UPLAPPENT</a> on page 1616.
Approval Progress	In Exit	C1-UPLAPPEXT	C1-UPLAPPEXT	Refer to <a href="#">C1-UPLAPPEXT</a> on page 1616.
Approval Progress	In Exit	F1-TODOCOMPL	F1-TODOCOMPL	Refer to <a href="#">F1-TODOCOMPL</a> on page 1256.
Approved	Monitor	F1-AT-RQJ	F1-GEN-BOMNJ	Refer to <a href="#">F1-AT-RQJ</a> on page 1257.
Approved	Enter	C1-DEFERUPLD	C1-DEFERUPLD	Refer to <a href="#">C1-DEFERUPLD</a> on page 1616.
Rejected	—	—	—	—
Deferred Processing	Monitor	F1-AT-RQJ	F1-GEN-BOMNJ	Refer to <a href="#">F1-AT-RQJ</a> on page 1257.
Processing	Monitor	F1-AT-RQJ	F1-GEN-BOMNJ	Refer to <a href="#">F1-AT-RQJ</a> on page 1257.
Processing	Enter	C1-BLVLVLPRO	C1-BLVLVLPRO	Refer to <a href="#">C1-BLVLVLPRO</a> on page 1619.
Processed	—	—	—	—

## C1-BLVUPLDTL

This algorithm reads the data in the **BO\_DATA\_AREA** column of the **C1\_UPL\_REQUEST** table and accordingly inserts the records in the **C1\_UPLOAD\_REQ\_DTLS** table. In addition, the status of each record in the **C1\_UPLOAD\_REQ\_DTLS** table is set to **Pending**.

## C1-BLVLDERIV

This algorithm reads the data in the **BO\_DATA\_AREA** column of the **C1\_UPLOAD\_REQ\_DTLS** table and then derives the bill group (person) ID using the bill group (person) identifier type and bill group (person) identifier combination whenever the bill group ID is not specified in the record. Once the bill group ID is derived, the corresponding record is updated in the **C1\_UPLOAD\_REQ\_DTLS** table. If the system could not derive the bill group ID using the bill group identifier type and bill group identifier combination, the status of the record in the **C1\_UPLOAD\_REQ\_DTLS** table is changed to **Invalid**.

## C1-BLVLVALID

This algorithm is invoked when the user clicks the **Validate** button. It validates the records which are in the **Pending** status. It checks the following:

- The parent customer's person type is set to **Parent Customer** in the system.
- All mandatory information is available in the bill group derivation and pricing parameters record.
- Either the bill group (person) identifier type and bill group (person) identifier or the bill group (person) ID is available in the bill group derivation and pricing parameters record.
- The bill group identifier type is available when the bill group identifier is specified and vice versa.
- The number of characters specified in each field does not exceed the maximum field length.
- A bill group with the specified bill group ID exists in the system.
- The bill group is the child person of the parent customer.
- The bill group's person type is set to **Bill Group** in the system.
- The relationship between the bill group and parent customer is effective on the system date.
- The bill group is related to the parent customer using the relationship type which is specified in the **Person Relationship Type** option type of the **C1-ASOBLLNG** feature configuration.
- A duplicate record with the source system, parameter 1, parameter 2, parameter 3, parameter 4, and effective date combination does not exist in the **C1\_BILL\_LVL** table.
- A duplicate record with the source system, parameter 1, parameter 2, parameter 3, parameter 4, and effective date combination does not exist in the **C1\_UPLOAD\_REQ\_DTLS** table.
- The source system exists in the extendable lookup which is specified in the **Source System Extendable Lookup** parameter.
- The bill group sort record with the bill group ID and sort ID combination already exists in the system.
- The effective date specified in the record is within the date range of the effective bill group sort record.

If the above mentioned validations are successful, the status of the record in the **C1\_UPLOAD\_REQ\_DTLS** table is changed to **Valid**. However, if any of the above validation fails, the status of the record in the **C1\_UPLOAD\_REQ\_DTLS** table is changed to **Invalid**.

It contains the following parameter:

- **Source System Extendable Lookup** – Used to specify the source system extendable lookup business object. The bill group derivation and pricing parameters records should contain the source system which is already defined in this extendable lookup.

## F1-AT-RQJ

This algorithm transitions the current status of the business object to the specified status. It contains the following parameters:

- **Next Status** – Used when you want to override the default next status specified in the lifecycle.
- **Next Transition Condition** – Used when you want to override the default next transition condition specified in the lifecycle.

At a time, you can specify value for either the **Next Status** or **Next Transition Condition** parameter. If you don't specify any value for these parameters, the system will transition the business object to the default next status specified in its lifecycle.

## C1-UPLSUBENT

This algorithm is invoked when the user clicks the **Submit** button. It checks whether the approval is required for the upload request. If the approval is required for an upload request, the status of the upload request is changed to **Approval In Progress**. However, if the approval is not required for an upload request, the status of the upload request remains in the **Submitted** status.

## C1-DEFERUPLD

This algorithm is invoked when the status of the upload request is changed to **Submitted** or **Approved**. It checks whether the upload request must be processed in the real time (i.e. immediately) or in the deferred mode (i.e. in the background). If the number of valid records in the upload request does not exceed the online record process limit, the system changes the status of the upload request to **Processing**. However, if the number of valid records in the upload request exceeds the online record process limit, the system changes the status of the upload request to **Deferred Processing**.

It contains the following parameter:

- **Online Record Process Limit** – Used to indicate the maximum number of valid records you can process in the real time (i.e. immediately).

## C1-UPLAPPENT

This algorithm creates a To Do using the To Do type specified in the upload request type. The To Do is sent to the appropriate users with the To Do role which is specified in the upload request type. In addition, a log entry is added when a To Do is created using the To Do type.

## C1-UPLAPPEXT

This algorithm checks whether the approver is associated with the approval To Do role specified in the upload request type. If not, it does not allow the approver to approve or reject the upload request. In addition, it does not allow the submitter to approve or reject the upload request.

## F1-TODOCOMPL

This algorithm completes To Do entries that are created for the business object when the business object exits the given status. It finds and completes all open To Do entries where the business object's primary key is defined as a drill key. However, if the **Exclude To Do Entries From Auto Completion** characteristic is set to **Y** for the business object, the system does not automatically complete the respective To Do entry.

## C1-BLVLVLP

This algorithm fetches a list of records which are in the **Valid** status. For each valid record with a unique combination of the source system, parameter 1, parameter 2, parameter 3, parameter 4, and effective date, it creates one bill group derivation and pricing parameters record using the entity business object defined in the upload request type. If the record

is successfully processed, the status of the record is changed to **Processed**. However, if the record could not be processed successfully due to any reason, the status of the record is changed to **Error**. Finally, the status of the upload request is changed to **Processed**.

## CSV File Format for Account Bill Cycle Upload Request

Before uploading the account bill cycle file, you need to ensure that the CSV file contains the following columns:

Column Name	Description	Mandatory (Yes or No)
Account Identifier Type	Used to specify the account identifier type.	Yes (Conditional) <b>Note:</b> This data is required when the account ID is not specified.
Account Identifier	Used to specify the identifier of the account whose bill cycle you want to update.	Yes (Conditional) <b>Note:</b> This data is required when the account ID is not specified.
Account ID	Used to indicate the account whose bill cycle you want to update. <b>Note:</b> If you do not specify the account ID, the system derives the account ID using the account identifier type and account identifier combination.	No
Bill Cycle	Used to specify the bill cycle. <b>Note:</b> You must specify a valid bill cycle which is associated with the division to which the account belongs.	Yes

## CSV File Format for Contract Rider Upload Request

Before uploading a contract rider file, you need to ensure that the CSV file contains the following columns:

Column Name	Description	Mandatory (Yes or No)
Account Identifier Type	Used to specify the account identifier type.	Yes (Conditional) <b>Note:</b> This data is required when the account ID and contract ID are not specified.
Account Identifier	Used to specify the identifier of the account whose contract you want to update.	Yes (Conditional) <b>Note:</b> This data is required when the account ID and contract ID are not specified.

Column Name	Description	Mandatory (Yes or No)
Account ID	Used to indicate the account whose contract you want to update.	Yes (Conditional)  <b>Note:</b> This data is required when the account identifier type, account identifier, and contract ID are not specified.
Contract Type	Used to indicate the type of the contract whose details you want to update.  <b>Note:</b> You must specify a contract type which already exists in the system.	Yes (Conditional)  <b>Note:</b> This data is required when the contract ID is not specified.
Contract ID	Used to indicate the contract whose contract rider information you want to update.  <b>Note:</b> If you do not specify the contract ID, the system derives the active contract using the account ID and contract type combination.	No
Start Date	Used to specify the date from when the bill factor is effective for the contract.  <b>Note:</b> The start date cannot be later than the end date.	Yes
End Date	Used to specify the date till when the bill factor is effective for the contract.  <b>Note:</b> The end date cannot be earlier than the start date.	No
Bill Factor	Used to specify the bill factor.  <b>Note:</b> You must specify a valid bill factor where the <b>Contract Rider Applicability</b> flag is set to <b>Y</b> .	Yes

## CSV File Format for Billable Charge Upload

Before uploading a billable charge file, you need to ensure that the CSV file contains the following columns:

Column Name	Description	Mandatory (Yes or No)
Account Identifier Type	Used to specify the account identifier type.	Yes (Conditional)  <b>Note:</b> This data is required when the <b>Account ID</b> is not specified.

Column Name	Description	Mandatory (Yes or No)
Account Identifier	Used to specify the account identifier of the account for which you want to create the billable charge.	Yes (Conditional) <b>Note:</b> This data is required when the <b>Account ID</b> is not specified.
Account ID	Used to specify the account for which you want to create the billable charge.	Yes (Conditional) <b>Note:</b> This data is required when the <b>Account Identifier Type</b> and <b>Account Identifier</b> is not specified.
Contract ID	Used to specify the contract against which you want to create the billable charge.	Yes (Conditional) <b>Note:</b> This data is required when you want to create the billable charge against a specific contract on the account. If this data is not specified then billable charge is created against a contract with highest priority.
Start Date	Used to specify the start date of billable charge.	Yes
End Date	Used to specify the end date of billable charge.	Yes
Charge Type	Used to specify the charge type for which you want to create a billable charge.	No
Description On Bill	Used to specify description for a billable charge.	Yes
Recurring Flag	Used to indicate whether recurring bill segments must be created at the intervals defined in the bill period or at the set policy invoice frequency. The valid values are: <ul style="list-style-type: none"> <li>• BP</li> <li>• FR</li> </ul>	Yes (Conditional) <b>Note:</b> This data is required if <b>Frequency</b> or <b>Bill Period</b> is specified.
Frequency	Used to specify the invoice frequency at which the recurring bill segments must be created.	Yes (Conditional) <b>Note:</b> This data is required if <b>Recurring Flag</b> is FR.
Bill Period	Used to specify the bill period that you want to use for specifying the intervals at which the recurring bill segments must be created.	Yes (Conditional) <b>Note:</b> This data is required if <b>Recurring Flag</b> is BP.
Bill After	Used to specify the date after which the bill must be generated for the billable charge.	No
Adhoc Bill	Used to indicate whether the billable charge should be considered during adhoc or regular billing.	No

Column Name	Description	Mandatory (Yes or No)
Description on Bill1, Description on Bill2, ....., Description on Bill5	Used to specify description for the billable charge lines.	Yes (Conditional) <b>Note:</b> This data is required when the charge amount is specified.
Currency1, Currency2, ....., Currency5	Used to specify the currency in which the amount is charged. <b>Note:</b> If you specify a currency other than the account's invoice currency, the system will do the currency conversion if the appropriate exchange rate is available in the system.	Yes (Conditional) <b>Note:</b> This data is required when the charge amount is specified.
Amount1, Amount2, ....., Amount5	Used to specify the charge amount.	Yes (Conditional) <b>Note:</b> This data is required when the description on bill or currency is specified.
Show On Bill1, Show on Bill2, ....., Show On Bill5	Used to indicate whether the charge should appear on the person's printed bill or not. The valid values are: <ul style="list-style-type: none"> <li>• true</li> <li>• false</li> </ul> <b>Note:</b> By default, the value will be set to <b>true</b> if the column does not contain any value.	No
Summary1, Summary2, ....., Summary5	Used to indicate whether the charge should be included in the summary line or not. The valid value are: <ul style="list-style-type: none"> <li>• true</li> <li>• false</li> </ul> <b>Note:</b> By default, the value will be set to <b>true</b> if the column does not contain any value.	No
Memo Only1, Memo Only2, ....., Memo Only5	Used to indicate whether the charge should be included in the bill amount or not. The valid values are: <ul style="list-style-type: none"> <li>• true</li> <li>• false</li> </ul> <b>Note:</b> By default, the value will be set to <b>false</b> if the column does not contain any value.	No

Column Name	Description	Mandatory (Yes or No)
GL Distribution Code1, GL Distribution Code2, ....., GL distribution Code5	Used to specify the distribution code which indicates the GL account associated with the charge.	Yes (Conditional)  <b>Note:</b> This data is required when <b>false</b> is specified in the <b>Memo Only</b> column corresponding to the bill line description.
Price Item	Used to specify the price item code.	Yes (Conditional)  <b>Note:</b> This data is required when <b>Variance Parameter</b> or, <b>Price Item Parameter</b> and <b>Price Item Parameter Value</b> is specified.
Variance Parameter	Used to indicate the variance that must be used along with the price item for determining the price item pricing.	Yes (Conditional)  <b>Note:</b> This data is required when <b>Price Item</b> is specified and <b>Price Item Parameter</b> and <b>Price Item Parameter Value</b> are not specified.
Price Item Parameter1, Price Item Parameter2, ....., Price Item Parameter15	Used to indicate the price item parameter that must be used along with the price item for determining the price item pricing.  <b>Note:</b> If the data in these columns will be used for price item parameter mapping, you must not use the equal to (=) and tilde (~) symbols in these columns.	Yes (Conditional)  <b>Note:</b> This data is required when <b>Price Item</b> is specified and <b>Variance Parameter</b> is not specified.
Price Item Parameter Value1, Price Item Parameter Value2, ....., Price Item Parameter Value15	Used to specify the parameter value.  <b>Note:</b> If the data in these columns will be used for price item parameter mapping, you must not use the equal to (=) and tilde (~) symbols in these columns.	Yes (Conditional)  <b>Note:</b> This data is required when <b>Price Item</b> is specified and <b>Variance Parameter</b> is not specified.
SQI1, SQI2, ....., SQI5	Used to indicate the service quantity identifier that must be used for calculating the price item charges.	Yes (Conditional)  <b>Note:</b> This data is required when the service quantity is specified.
SQI Value1, SQI Value2, ....., SQI Value5	Used to specify the number of units of the service quantity.	Yes (Conditional)  <b>Note:</b> This data is required when the SQI is specified.



Column Name	Description	Mandatory (Yes or No)
Effective Date1, Effective Date2, ....., Effective Date20	Used to indicate the effective date of the characteristics.	Yes (Conditional)  <b>Note:</b> This data is required when <b>Char Type</b> or <b>Char Val</b> is specified.
Char Type1, Char Type2, ....., Char Type20	Used to indicate the characteristic that must be defined for the billable charge.	Yes (Conditional)  <b>Note:</b> This data is required when <b>Effective Date</b> or <b>Char Val</b> is specified.
Char Value1, Char Value2, ....., Char Value20	Used to specify the value of the characteristic type.	Yes (Conditional)  <b>Note:</b> This data is required when <b>Effective Date</b> or <b>Char Type</b> is specified.

## CSV File Format for Hold Upload Request

Before uploading a hold request file, you need to ensure that the CSV file contains the following columns:

Column Name	Description	Mandatory (Yes or No)
Hold Request Type	Used to specify the hold request type.  <b>Note:</b> You must specify a valid hold request type which is in the <b>Active</b> status.	Yes
Start Date	Used to specify the date from when the hold request is effective.  <b>Note:</b> The hold request start date cannot be later than the hold request end date.	Yes
End Date	Used to specify the date till when the hold request is effective.  <b>Note:</b> The hold request end date cannot be earlier than the hold request start date.	Yes
Hold Reason	Used to indicate the reason why you want to hold the entity.  <b>Note:</b> The hold reason must exist in the <b>HOLD_REASON_FLG</b> lookup field and its status must be <b>Active</b> .	Yes

Column Name	Description	Mandatory (Yes or No)
Hold Entity	Used to indicate the type of the entity for which you want to create the hold request. The valid values are: <ul style="list-style-type: none"> <li>• ACCT</li> <li>• BILL</li> <li>• PERS</li> </ul>	Yes
Account Identifier Type	Used to specify the account identifier type.	Yes (Conditional) <div style="border: 1px solid black; padding: 2px; margin-top: 5px;"><b>Note:</b> This data is required when the hold entity is <b>ACCT</b> and the entity ID is not specified.</div>
Account Identifier	Used to specify the identifier of the account for which you want to create the hold request.	Yes (Conditional) <div style="border: 1px solid black; padding: 2px; margin-top: 5px;"><b>Note:</b> This data is required when the hold entity is <b>ACCT</b> and the entity ID is not specified.</div>
Person Identifier Type	Used to specify the person identifier type.	Yes (Conditional) <div style="border: 1px solid black; padding: 2px; margin-top: 5px;"><b>Note:</b> This data is required when the hold entity is <b>PERS</b> and the entity ID is not specified.</div>
Person Identifier	Used to specify the identifier of the person for which you want to create the hold request.	Yes (Conditional) <div style="border: 1px solid black; padding: 2px; margin-top: 5px;"><b>Note:</b> This data is required when the hold entity is <b>PERS</b> and the entity ID is not specified.</div>
Hold Entity ID	Used to specify the entity ID. <div style="border: 1px solid black; padding: 2px; margin-top: 5px;"><b>Note:</b> If the hold entity is <b>ACCT</b>, you must specify the account ID in this field. If the hold entity is <b>PERS</b>, you must specify the person ID in this field. And, if the hold entity is <b>BILL</b>, you must specify the bill ID in this field.  If you do not specify the account ID, the system derives the account ID using the account identifier type and account identifier combination. Similarly, if you do not specify the person ID, the system derives the person ID using the person identifier type and person identifier combination.</div>	Yes (Conditional) <div style="border: 1px solid black; padding: 2px; margin-top: 5px;"><b>Note:</b> This data is required when the hold entity is <b>BILL</b>.</div>
Comments	Used to specify additional information about the hold request.	No

Column Name	Description	Mandatory (Yes or No)
Hold Entity Start Date	<p>Used to specify the date from when you want to hold the entity.</p> <div data-bbox="496 289 1118 548" style="border: 1px solid black; padding: 5px;"> <p><b>Note:</b></p> <p>The hold entity start date must be between the hold request start and end dates and between at least one process's start and end dates.</p> <p>The hold entity start date cannot be later than the hold entity end date.</p> </div>	Yes
Hold Entity End Date	<p>Used to specify the date till when you want to hold the entity.</p> <div data-bbox="496 655 1118 884" style="border: 1px solid black; padding: 5px;"> <p><b>Note:</b></p> <p>The hold entity end date must be between hold request start and end dates and between the process's start and end dates.</p> <p>The hold entity end date cannot be earlier than the hold entity start date.</p> </div>	No
Hold Funding	<p>Used to indicate whether you want to hold the funding process for the entity. The valid values are:</p> <ul style="list-style-type: none"> <li>• Y</li> <li>• N</li> </ul> <div data-bbox="496 1087 1118 1167" style="border: 1px solid black; padding: 5px;"> <p><b>Note:</b> You can hold the funding process only when the hold entity is <b>PERS</b> or <b>BILL</b>.</p> </div>	No
Hold Funding Start Date	<p>Used to specify the date from when you want to hold the funding process.</p> <div data-bbox="496 1276 1118 1505" style="border: 1px solid black; padding: 5px;"> <p><b>Note:</b></p> <p>The hold funding start date must be between the hold request start and end dates.</p> <p>The hold funding start date cannot be later than the hold funding end date.</p> </div>	<p>Yes (Conditional)</p> <div data-bbox="1143 1247 1463 1356" style="border: 1px solid black; padding: 5px;"> <p><b>Note:</b> This data is required when the funding process must be kept on hold.</p> </div>
Hold Funding End Date	<p>Used to specify the date till when you want to hold the funding process.</p> <div data-bbox="496 1612 1118 1841" style="border: 1px solid black; padding: 5px;"> <p><b>Note:</b></p> <p>The hold funding end date must be between the hold request start and end dates.</p> <p>The hold funding end date cannot be earlier than the hold funding start date.</p> </div>	No

Column Name	Description	Mandatory (Yes or No)
Hold Overdue	Used to indicate whether you want to hold the overdue process for the entity. The valid values are: <ul style="list-style-type: none"> <li>• Y</li> <li>• N</li> </ul>	No
Hold Overdue Start Date	Used to specify the date from when you want to hold the overdue process. <p><b>Note:</b></p> <p>The hold overdue start date must be between the hold request start and end dates.</p> <p>The hold overdue start date cannot be later than the hold overdue end date.</p>	Yes (Conditional) <p><b>Note:</b> This data is required when the overdue process must be kept on hold.</p>
Hold Overdue End Date	Used to specify the date till when you want to hold the overdue process. <p><b>Note:</b></p> <p>The hold overdue end date must be between the hold request start and end dates.</p> <p>The hold overdue end date cannot be earlier than the hold overdue start date.</p>	No
Hold Bill Generation	Used to indicate whether you want to hold the bill generation process for the entity. The valid values are: <ul style="list-style-type: none"> <li>• Y</li> <li>• N</li> </ul>	No
Hold Bill Generation Start Date	Used to specify the date from when you want to hold the bill generation process. <p><b>Note:</b></p> <p>The hold bill generation start date must be between the hold request start and end dates.</p> <p>The hold bill generation start date cannot be later than the hold bill generation end date.</p>	Yes (Conditional) <p><b>Note:</b> This data is required when the bill generation process must be kept on hold.</p>
Hold Bill Generation End Date	Used to specify the date till when you want to hold the bill generation process. <p><b>Note:</b></p> <p>The hold bill generation end date must be between the hold request start and end dates.</p> <p>The hold bill generation end date cannot be earlier than the hold bill generation start date.</p>	No

Column Name	Description	Mandatory (Yes or No)
Hold Auto Pay	Used to indicate whether you want to hold the automatic payment process for the entity. The valid values are: <ul style="list-style-type: none"> <li>• Y</li> <li>• N</li> </ul>	No
Hold Autopay Start Date	Used to specify the date from when you want to hold the automatic payment process. <p><b>Note:</b></p> <p>The hold autopay start date must be between the hold request start and end dates.</p> <p>The hold autopay start date cannot be later than the hold autopay end date.</p>	Yes (Conditional) <p><b>Note:</b> This data is required when the automatic payment process must be kept on hold.</p>
Hold Autopay End Date	Used to specify the date till when you want to hold the automatic payment process. <p><b>Note:</b></p> <p>The hold autopay end date must be between the hold request start and end dates.</p> <p>The hold autopay end date cannot be earlier than the hold autopay start date.</p>	No
Effective Date1, Effective Date2, ....., Effective Date5	Used to specify the date from when the characteristic is effective for the hold request.	Yes (Conditional) <p><b>Note:</b> This data is required when the characteristic type or characteristic value is specified.</p>
Char Type1, Char Type2, ....., Char Type5	Used to indicate the characteristic that must be defined for the hold request. <p><b>Note:</b> You must specify a characteristic type where the characteristic entity is set to <b>Hold Request</b>.</p>	Yes (Conditional) <p><b>Note:</b> This data is required when the effective date or characteristic value is specified.</p>
Char Val1, Char Val2, ....., Char Val5	Used to specify the value for the characteristic type.	Yes (Conditional) <p><b>Note:</b> This data is required when the effective date or characteristic type is specified.</p>

## CSV File Format for Refund Request Upload

Before uploading a refund request file, you need to ensure that the CSV file contains the following columns:

Column Name	Description	Mandatory (Yes or No)
Refund Request Type	Used to specify the refund request type.	Yes
Account Identifier Type	Used to specify the account identifier type.	Yes (Conditional) <b>Note:</b> This data is required when the <b>Account ID</b> is not specified.
Account Identifier	Used to specify the account identifier of the account for which you want to create the refund request.	Yes (Conditional) <b>Note:</b> This data is required when the <b>Account ID</b> is not specified.
Account ID	Used to specify the account for which you want to create the refund request.	Yes (Conditional) <b>Note:</b> This data is required when the <b>Account Identifier Type</b> and <b>Account Identifier</b> are not specified.
Entity Type	Used to specify the entity type.	Yes
Entity ID	Used to specify the entity ID.	Yes
Adjustment Type	Used to specify the adjustment type using which the refund adjustments are created.	No
Refund Amount	Used to specify the amount that you want to refund.	Yes
Comments	Used to specify the comments which are added on the refund request.	No
Effective Date1, Effective Date2, ....., Effective Date5	Used to indicate the effective date of the characteristics.	Yes (Conditional) <b>Note:</b> This data is required when <b>Char Type</b> or <b>Char Val</b> is specified.
Char Type1, Char Type2, ....., Char Type5	Used to indicate the characteristic that must be defined for the refund request.	Yes (Conditional) <b>Note:</b> This data is required when <b>Effective Date</b> or <b>Char Val</b> is specified.
Char Val1, Char Val2, ....., Char Val5	Used to specify the value of the characteristic type.	Yes (Conditional) <b>Note:</b> This data is required when <b>Effective Date</b> or <b>Char Type</b> is specified.

## CSV File Format for Write Off Request Upload

Before uploading a write off request file, you need to ensure that the CSV file contains the following columns:

Column Name	Description	Mandatory (Yes or No)
Write Off Request Type	Used to specify the write off request type.	Yes
Account Identifier Type	Used to specify the account identifier type.	Yes (Conditional) <b>Note:</b> This data is required when the <b>Account ID</b> is not specified.
Account Identifier	Used to specify the account identifier of the account for which you want to create the write off request.	Yes (Conditional) <b>Note:</b> This data is required when the <b>Account ID</b> is not specified.
Account ID	Used to specify the account for which you want to create the write off request.	Yes (Conditional) <b>Note:</b> This data is required when the <b>Account Identifier Type</b> and <b>Account Identifier</b> are not specified.
Entity Type	Used to specify the entity type.	Yes
Entity ID	Used to specify the entity ID.	Yes
Adjustment Type	Used to specify the adjustment type using which the write off adjustments are created.	No
Write Off Amount	Used to specify the amount that you want to write off.	Yes
Comments	Used to specify the comments which are added on the write off request.	No
Effective Date1, Effective Date2, ....., Effective Date5	Used to indicate the effective date of the characteristics.	Yes (Conditional) <b>Note:</b> This data is required when <b>Char Type</b> or <b>Char Val</b> is specified.
Char Type1, Char Type2, ....., Char Type5	Used to indicate the characteristic that must be defined for the write off request.	Yes (Conditional) <b>Note:</b> This data is required when <b>Effective Date</b> or <b>Char Val</b> is specified.
Char Val1, Char Val2, ....., Char Val5	Used to specify the value of the characteristic type.	Yes (Conditional) <b>Note:</b> This data is required when <b>Effective Date</b> or <b>Char Type</b> is specified.

## CSV File Format for Reinstatement Upload Request

Before uploading a policy reinstatement file, you need to ensure that the CSV file contains the following columns:

Column Name	Description	Mandatory (Yes or No)
Policy ID	Used to indicate the policy which you want to reinstate.  <b>Note:</b> If you do not specify the policy ID, the system derives the policy ID using the source system and policy number combination.	No
Source System	Used to indicate the external system from where the policy is originated.	Yes (Conditional)  <b>Note:</b> This data is required when the policy ID is not specified.
Policy Number	Used to indicate the policy number.	Yes (Conditional)  <b>Note:</b> This data is required when the policy ID is not specified.
Reinstatement Reason	Used to indicate the reason why you want to reinstate the policy.  <b>Note:</b> You must specify a reason which is defined for the status specified in the <b>Policy Reinstatement Status for Reason Verification</b> parameter of the <b>C1-REN-VALID</b> algorithm.	Yes

## CSV File Format for Bill Group Sorting Upload Request

Before uploading a bill group sorting file, you need to ensure that the CSV file contains the following values in the specified order separated by a comma:

Sr. No.	Value	Description	Mandatory (Yes or No)
1	Bill Group ID	Used to indicate the bill group (i.e. person) for whom you want to define the sort ID.  <b>Note:</b> You must specify an effective child person of the parent customer for whom you are creating the bill group sorting upload request. In addition, note that you must specify a child person whose person type is set to <b>Bill Group</b> and who is related to the parent customer using a relationship type which is specified in the <b>Person Relationship Type</b> option type of the <b>C1-ASOBLLNG</b> feature configuration.	Yes (Conditional)  <b>Note:</b> This data is required when the bill group (i.e. person) identifier type and bill group (i.e. person) identifier are not specified.
2	Bill Group Identifier Type	Used to specify the bill group (i.e. person) identifier type.	Yes (Conditional)  <b>Note:</b> This data is required when the bill group (i.e. person) ID is not specified.



Sr. No.	Value	Description	Mandatory (Yes or No)
3	Bill Group Identifier	Used to specify identifier of the bill group (i.e. person) for whom you want to define the sort ID.	Yes (Conditional) <b>Note:</b> This data is required when the bill group (i.e. person) ID is not specified.
4	Sort ID	Used to specify the sort ID.	Yes
5	Description	Used to specify the description for the sort ID.	Yes
6	Start Date	Used to specify the date from when the sort ID is effective for the bill group. <b>Note:</b> The start date cannot be later than the end date.	Yes
7	End Date	Used to specify the date till when the sort ID is effective for the bill group. <b>Note:</b> The end date cannot be earlier than the start date.	No

#### Related Topics

For more information on...	See...
How to setup the <b>C1-ASOBLNG</b> feature configuration	<a href="#">Setting the C1-ASOBLNG Feature Configuration</a> on page 2889

## CSV File Format for Bill Group Derivation and Pricing Parameters Upload Request

Before uploading a bill group derivation and pricing parameters file, you need to ensure that the CSV file contains the following values in the specified order separated by a comma:

Sr. No.	Value	Description	Mandatory (Yes or No)
1	Source System	Used to indicate the source system from where the claim and enrollment transactions are received. <b>Note:</b> You must specify a source system which already exists in the extendable lookup which is specified in the <b>Source System Extendable Lookup</b> parameter of the <b>C1-BLVLVALID</b> algorithm.	Yes
2	Parameter 1	Used to specify the employee attribute based on which you want to derive the bill group. <b>Note:</b> You must not specify the ampersand (&) character in the parameter 1.	Yes

Sr. No.	Value	Description	Mandatory (Yes or No)
3	Parameter 2	Used to specify the employee attribute based on which you want to derive the bill group.  <b>Note:</b> You must not specify the ampersand (&) character in the parameter 2.	No
4	Parameter 3	Used to specify the employee attribute based on which you want to derive the bill group.  <b>Note:</b> You must not specify the ampersand (&) character in the parameter 3.	No
5	Parameter 4	Used to specify the employee attribute based on which you want to derive the bill group.  <b>Note:</b> You must not specify the ampersand (&) character in the parameter 4.	No
6	Effective Date	Used to specify the date from when the derivation and pricing parameters are effective for the bill group and sort ID combination.  <b>Note:</b> The effective date must be within the date range of the sort ID defined for the bill group.	Yes
7	Bill Group ID	Used to indicate the bill group (i.e. person) for whom you want to define the derivation and pricing parameters.  <b>Note:</b> You must specify an effective child person of the parent customer for whom you are creating the bill group derivation and pricing parameters upload request. In addition, note that you must specify a child person whose person type is set to <b>Bill Group</b> and who is related to the parent customer using a relationship type which is specified in the <b>Person Relationship Type</b> option type of the <b>C1-ASOBLNG</b> feature configuration.	Yes (Conditional)  <b>Note:</b> This data is required when the bill group (i.e. person) identifier type and bill group (i.e. person) identifier are not specified.
8	Bill Group Identifier Type	Used to specify the bill group (i.e. person) identifier type.	Yes (Conditional)  <b>Note:</b> This data is required when the bill group (i.e. person) ID is not specified.
9	Bill Group Identifier	Used to specify identifier of the bill group (i.e. person) for whom you want to define the derivation and pricing parameters.	Yes (Conditional)  <b>Note:</b> This data is required when the bill group (i.e. person) ID is not specified.

Sr. No.	Value	Description	Mandatory (Yes or No)
10	Sort ID	Used to indicate the sort ID of the bill group for which you want to define the derivation and pricing parameters.	Yes

### Related Topics

For more information on...	See...
How to setup the <b>C1-ASOBLNG</b> feature configuration	<a href="#">Setting the C1-ASOBLNG Feature Configuration</a> on page 2889

## Upload Request Type

Oracle Revenue Management and Billing allows you to define an upload request type using which you can upload a file. An upload request of the specified upload request type is created on uploading the file. It is the upload request type which helps the system to understand how to process the file. If you upload a file which exceeds the maximum file size, the system will not allow you to upload the file.

The **Adjustment Upload Request Type (C1-AdjRequestType)** business object is used for the maintenance of upload request types for uploading CSV data. Configurations like upload file size, approval workflow can be configured using this object. If you are going to upload adjustment data files using an upload request type, you need to specify the match types (using which the adjustments must be created) in the upload request type. At present, the following two match types are shipped with the product:

- Contract
- Contract Type

You can also define custom match types, if required. You must use the **ADJ\_MATCH\_TYPE** lookup field to add a new match type. You need to attach an algorithm to each match type to determine the contract against which the adjustment must be created. At present, the following algorithm types and sample algorithms are shipped with the product:

Match Type	Algorithm Type	Sample Algorithm	Algorithm Description
Contract	C1-MTCIALG	C1-MTCIALG	This algorithm fetches contract ID for each adjustment record where the match type is set to <b>Contract (CONT)</b> .
Contract Type	C1-MTCTALG	C1-MTCTALG	This algorithm fetches contract ID based on the contract type and account ID for each adjustment record where the match type is set to <b>Contract Type (CNTY)</b> . If there are multiple active contracts of the specified contract type on the account, the contract ID with the latest start date will be fetched.

The **Upload Request Type (C1-UpRequestType)** business object will be used for the maintenance of upload request types for uploading CSV data. Configurations like upload file size, approval workflow can be configured using this object. The system enables you to upload data for the following using the **Upload Request** feature:

- Billable Charge (Adhoc and Regular)
- Hold Request
- Refund Request
- Write Off Request
- Policy Reinstatement

- Bill Group Sort ID
- Derivation and Pricing Parameters for a Bill Group and Sort ID Combination

It also enables you to update the following information:

- Contract rider of a contract
- Bill cycle of an account

It is the upload request type which helps the system to determine:

- Whether the file must be approved by the approver before creating or updating the entities
- Which business object must be used for creating the upload request
- Which business object must be used for creating or updating entities through an upload request
- Which foreign key reference must be used for generating information string for the entity
- A set of fields using which you can search records uploaded through an upload request





You can also define custom algorithm types and algorithms, if required. The **Upload Request Type** screen allows you to define, edit, copy, and delete an upload request type. This screen consists of the following zones:

- [Upload Request Type List](#) on page 1110
- [Upload Request Type](#) on page 1111

**Parent topic:** [Upload Request](#) on page 1573

## Upload Request Type List

The **Upload Request Type List** zone lists upload request types that are already defined in the system. It contains the following columns:

Column Name	Column Description
Upload Request Type	Displays the upload request type.
Description	Displays the description of the upload request type.
Edit	On clicking the <b>Edit</b> (  ) icon, the <b>Upload Request Type</b> screen appears where you can edit the details of the upload request type.
Duplicate	On clicking the <b>Duplicate</b> (  ) icon, the <b>Upload Request Type</b> screen appears where you can define an upload request type using an existing upload request type.
Delete	On clicking the <b>Delete</b> (  ) icon, you can delete the upload request type.  <b>Note:</b> You can delete an upload request type only when you have not uploaded a file (i.e. created an upload request) using the upload request type.
Mapping	On clicking the <b>Mapping</b> (  ) icon, the mapping screen appears where you can map the columns of CSV file with the upload request type.

On clicking the **Broadcast** () icon corresponding to an upload request type, the **Upload Request Type** zone appears with the details of the respective upload request type.

### Related Topics

For more information on...	See...
How to define an upload request type	<a href="#">Defining an Upload Request Type</a> on page 1114

For more information on...	See...
How to define characteristics for an upload request type	<a href="#">Defining Characteristics for an Upload Request Type</a> on page 1120
How to edit an upload request type	<a href="#">Editing an Upload Request Type</a> on page 1121
How to copy an upload request type	<a href="#">Copying an Upload Request Type</a> on page 1125
How to delete an upload request type	<a href="#">Deleting an Upload Request Type</a> on page 1130
How to map an upload request type	<a href="#">Mapping an Upload Request Type</a> on page 1129
How to view the details of an upload request type	<a href="#">Viewing the Upload Request Type Details</a> on page 1131

## Upload Request Type

The **Upload Request Type** zone displays the details of the upload request type. This zone contains the following sections:

- **Main** – This section provides basic information about the upload request type. It contains the following fields:

Field Name	Field Description
Upload Request Type	Displays the upload request type.
Upload Request Business Object	Indicates the business object that will be used to create the upload request. In addition, a context menu appears corresponding to this field which helps in navigating to other screens in the application.  <b>Note:</b> It has a link. On clicking the link, the <b>Business Object</b> screen appears where you can view the details of the respective business object.
Description	Displays the description of the upload request type.
Detailed Description	Displays additional information about the upload request type.
Status	Indicates the status of the upload request type. The valid values are: <ul style="list-style-type: none"> <li>• Active</li> <li>• Inactive</li> </ul>
File Size (KB)	Displays the maximum size of file (in kilobytes) that you can upload using the upload request type. If you upload a file which exceeds the maximum file size, the system will not allow you to upload the file.  <b>Note:</b> This field appears only when you create upload request type using <b>Adjustment Upload Request Type</b> business object.

Field Name	Field Description
Defer Algorithm	<p>Indicates the algorithm that will be triggered when you create entities (for example, adjustments) or approve the uploaded file (for example, adjustment data file). This algorithm checks whether the number of records in the uploaded file exceeds the online record process limit. If the number of records in the uploaded file does not exceed the online record process limit, the system creates the entities in the real time (i.e. immediately). However, if the number of records in the uploaded file exceeds the online record process limit, the system creates the entities (for example, adjustments) in the real time (i.e. immediately). However, if the number of records in the uploaded file exceeds the online record process limit, the system creates the entities (for example, adjustments) in the deferred mode.</p> <div data-bbox="602 546 1466 947" style="border: 1px solid black; padding: 5px;"> <p><b>Note:</b></p> <p>This field appears only when you create upload request type using <b>Adjustment Upload Request Type</b> business object.</p> <p>It has a link. On clicking the link, the <b>Algorithm</b> screen appears where you can view the details of the respective algorithm.</p> <p>In <b>Upload Request Type</b>, online and deferred mode is used for processing the file if approval is not required. The defer algorithm is invoked if the number of records to be processed on the respective business object is more than the count specified on the algorithm then the status for number of records is changed from <b>Validated</b> to <b>Deferred Processing</b> else the status is changed to <b>Processed</b>.</p> </div>
Approval Required	Indicates whether approval is required for a file which is uploaded using the upload request type.
Approval To Do Type	<p>Indicates that the To Do entry of the specified To Do type must be created when you submit the upload request for approval.</p> <div data-bbox="602 1136 1466 1329" style="border: 1px solid black; padding: 5px;"> <p><b>Note:</b></p> <p>This field appears only when the <b>Approval Required</b> check box is selected.</p> <p>It has a link. On clicking the link, the <b>To Do Type</b> screen appears with the details of the respective To Do type.</p> </div>
Approval To Do Role	<p>Indicates that users with the specified To Do role can only approve or reject the upload request submitted for approval.</p> <div data-bbox="602 1440 1466 1709" style="border: 1px solid black; padding: 5px;"> <p><b>Note:</b></p> <p>This field appears only when the <b>Approval Required</b> check box is selected.</p> <p>On selecting the <b>To Do Type</b>, the <b>To Do Roles</b> configured on the <b>To Do Type</b> is populated.</p> <p>It has a link. On clicking the link, the <b>To Do Role</b> screen appears with the details of the respective To Do role.</p> </div>

Field Name	Field Description
FK Reference	<p>Indicates the foreign key reference which specifies the created upload request type.</p> <p><b>Note:</b> This field appears only when you create upload request type using <b>Upload Request Type</b> business object. It has a link. On clicking the link, the <b>Foreign Key Reference</b> screen appears with the details of the respective foreign key.</p>

In addition, this section has the following columns:

Column Name	Column Description
Match Type	<p>Indicates the match type using which the adjustments must be created when you upload a file using the upload request type. The valid values are:</p> <ul style="list-style-type: none"> <li>Contract</li> <li>Contract Type</li> </ul> <p><b>Note:</b> The <b>Match Type</b> column is displayed for <b>Adjustment Upload Request Business Object</b>.</p>
Algorithm	<p>Indicates the algorithm that will be triggered when you upload an adjustment data file. This algorithm determines the contract against which the adjustment must be created.</p> <p><b>Note:</b> It has a link. On clicking the link, the <b>Algorithm</b> screen appears with the details of the respective algorithm. The <b>Algorithm</b> column is displayed for <b>Adjustment Upload Request Business Object</b>.</p>

- **Characteristics** – This section lists the characteristics defined for the upload request type. It contains the following columns:

Column Name	Column Description
Characteristic Type	Indicates the characteristic type.
Characteristic Value	Displays the value of the characteristic type.

- **Record Actions** – This section contains the following buttons:

Button Name	Button Description
Edit	Used to edit the details of the upload request type.
Delete	<p>Used to delete the upload request type.</p> <p><b>Note:</b> You can delete an upload request type only when you have not uploaded a file (i.e. created an upload request) using the upload request type.</p>
Duplicate	Used to create a new upload request type using an existing upload request type.

- **Record Information** – This section contains the following fields:

Field Name	Field Description
Business Object	Indicates the business object using which the upload request type is created. In addition, a context menu appears corresponding to this field which helps in navigating to other screens in the application.  <b>Note:</b> It has a link. On clicking the link, the <b>Business Object</b> screen appears where you can view the details of the respective business object.

By default, the **Upload Request Type** zone does not appear in the **Upload Request Type** screen. It appears only when you click the **Broadcast**  icon corresponding to an upload request type in the **Upload Request Type List** zone.

### Related Topics

For more information on...	See...
How to define an upload request type	<a href="#">Defining an Upload Request Type</a> on page 1114
How to define characteristics for an upload request type	<a href="#">Defining Characteristics for an Upload Request Type</a> on page 1120
How to edit an upload request type	<a href="#">Editing an Upload Request Type</a> on page 1121
How to copy an upload request type	<a href="#">Copying an Upload Request Type</a> on page 1125
How to delete an upload request type	<a href="#">Deleting an Upload Request Type</a> on page 1130
How to map an upload request type	<a href="#">Mapping an Upload Request Type</a> on page 1129
How to view the details of an upload request type	<a href="#">Viewing the Upload Request Type Details</a> on page 1131

## Defining an Upload Request Type

### Prerequisites

To define an upload request type, you should have:

- Upload request business objects defined in the application
- Defer algorithm for adjustment is defined using the **C1-UPLDEFEVL** algorithm type
- Defer algorithm for upload is defined using the **C1-DEFERUPLD** algorithm type
- Algorithm defined using the **C1-MTCIALG** algorithm type when you want to create adjustment using the **Contract** match type
- **C1-ADJUP** To Do type assigned to a To Do role whose users must receive To Do while submitting an adjustment upload request for approval
- **C1-BCUUR** To Do type assigned to a To Do role whose users must receive To Do while submitting a bill cycle update upload request for approval
- **C1-CRUUR** To Do type assigned to a To Do role whose users must receive To Do while submitting a contract rider update upload request for approval
- **C1-HLDUR** To Do type assigned to a To Do role whose users must receive To Do while submitting a hold upload request for approval
- **C1-REFUR** To Do type assigned to a To Do role whose users must receive To Do while submitting a refund upload request for approval
- **C1-WOUR** To Do type assigned to a To Do role whose users must receive To Do while submitting a write off upload request for approval



- **C1-BCUR** To Do type assigned to a To Do role whose users must receive To Do while submitting a billable charge upload request for approval
- **C1-RPUR** To Do type assigned to a To Do role whose users must receive To Do while submitting a reinstatement upload request for approval
- **C1-BGSRT** To Do type assigned to a To Do role whose users must receive To Do while submitting a bill group sorting upload request for approval
- **C1-BGDVP** To Do type assigned to a To Do role whose users must receive To Do while submitting a bill group derivation and pricing parameters upload request for approval

### **Procedure**

To define an upload request type:

1. Click the **Admin** link in the **Application** toolbar.  
A list appears.
2. From the **Admin** menu, select **U** and then click **Upload Request Type**.  
A sub-menu appears.
3. Click the **Add** option from the **Upload Request Type** sub-menu.

The **Select Business Object** screen appears. It contains the following field:

Field Name	Field Description	Mandatory (Yes or No)
Upload Request Type Business Object	Used to indicate the business object that you want to use to create the upload request type.	Yes

**Tip:** Alternatively, you can access the **Select Business Object** screen by clicking the **Add** button in the **Page Title** area of the **Upload Request Type** screen.

**Note:** The **Select Business Object** screen appears only when there are multiple upload request type business objects defined in the application. If there is only one upload request type business object defined in the application, the **Upload Request Type** screen appears.

4. Select the required upload request type business object from the respective field.
5. Click **OK**.

The **Upload Request Type** screen appears. It contains the following sections:



- **Main** – Used to specify basic details about the upload request type.
- **Characteristics** – Used to define characteristics for the upload request type.

The **Main** section contains the following fields:

Field Name	Field Description	Mandatory (Yes or No)
Upload Request Type	Used to specify the upload request type.	Yes
Upload Request Type Business Object	Indicates the upload request type business object used while defining the upload request type.	Not applicable
Upload Request Business Object	Used to indicate the business object that you want to use while creating the upload request.	Yes
Description	Used to specify the description for the upload request type.	Yes

Field Name	Field Description	Mandatory (Yes or No)
Detailed Description	Used to specify additional information about the upload request type.	No
Status	Used to indicate the status of the upload request type. The valid values are: <ul style="list-style-type: none"> <li>• Active</li> <li>• Inactive</li> </ul>	Yes
File Size (KB)	Used to specify the maximum size of file (in kilobytes) that you can upload using the upload request type. If you upload a file which exceeds the maximum file size, the system will not allow you to upload the file. <div style="border: 1px solid black; padding: 5px; margin-top: 10px;"> <p><b>Note:</b> This field appears when <b>Adjustment Upload Request Type</b> business object is selected.</p> </div>	Yes

Field Name	Field Description	Mandatory (Yes or No)
Defer Algorithm	<p>Used to attach an algorithm that will be triggered when you create entities (for example, adjustments) or approve the uploaded file (for example, adjustment data file). This algorithm checks whether the number of records in the uploaded file exceeds the online record process limit (defined in the Defer algorithm). If the number of records in the uploaded file does not exceed the online record process limit, the system creates the entities (for example, adjustments) in the real time (i.e. immediately). However, if the number of records in the uploaded file exceeds the online record process limit, the system creates the entities (for example, adjustments) in the deferred mode.</p> <div style="border: 1px solid black; padding: 5px;"> <p><b>Note:</b></p> <p>Deferred mode means in the background when the <b>Upload Request Periodic Monitor (C1-UPLRQ)</b> batch is invoked. You can configure the <b>Upload Request Periodic Monitor (C1-UPLRQ)</b> batch such that it is executed at regular intervals. When the <b>Upload Request Periodic Monitor (C1-UPLRQ)</b> batch is invoked, the system checks whether there are any upload requests in the <b>Deferred</b> status. If there is an upload request in the <b>Deferred</b> status, the system creates the entities (for example, adjustments).</p> <p>This field appears when <b>Adjustment Upload Request Type</b> business object is selected.</p> <p>In <b>Upload Request Type</b>, online and deferred mode is used for processing the file if approval is not required. The defer algorithm is invoked if the number of records to be processed on the respective business object is more than the count specified on the algorithm then the status for number of records is changed from <b>Validated</b> to <b>Deferred Processing</b> else the status is changed to <b>Processed</b>.</p> </div> <div style="border: 1px solid black; padding: 5px; margin-top: 5px;"> <p><b>Note:</b> The <b>Search</b>  icon appears corresponding to this field. On clicking the <b>Search</b> icon, the <b>Algorithm Search</b> window appears.</p> </div>	Yes

Field Name	Field Description	Mandatory (Yes or No)																						
Entity Business Object	<p>Used to indicate for creating Business Object of the entity using the upload request type.</p> <div style="border: 1px solid black; padding: 5px;"> <p><b>Note:</b></p> <p>The <b>Search</b>  icon appears corresponding to this field. On clicking the <b>Search</b> icon, the <b>Business Object Search</b> window appears.</p> <p>This field appears when <b>Upload Request Type</b> business object is selected.</p> </div>	No																						
Approval Required	Used to indicate whether approval is required for a file which is uploaded using the upload request type.	No																						
Approval To Do Type	<p>Used to indicate that To Do entry of the specified To Do type must be created when you submit the upload request for approval.</p> <div style="border: 1px solid black; padding: 5px;"> <p><b>Note:</b></p> <p>The <b>Search</b>  icon appears corresponding to this field. On clicking the <b>Search</b> icon, the <b>To Do Type Search</b> window appears.</p> <p>The following table lists the To Do type using which the To Do must be generated for the different upload requests:</p> <table border="1" data-bbox="667 1108 1138 1822"> <thead> <tr> <th>Upload Request</th> <th>To Do Type</th> </tr> </thead> <tbody> <tr> <td>Adjustment</td> <td>C1-ADJUP</td> </tr> <tr> <td>Bill Cycle Update</td> <td>C1-BCUUR</td> </tr> <tr> <td>Billable Charge</td> <td>C1-BCUR</td> </tr> <tr> <td>Contract Rider Update</td> <td>C1-CRUUR</td> </tr> <tr> <td>Hold Request</td> <td>C1-HLDUR</td> </tr> <tr> <td>Refund Request</td> <td>C1-REFUR</td> </tr> <tr> <td>Write Off Request</td> <td>C1-WOUR</td> </tr> <tr> <td>Policy Reinstatement</td> <td>C1-RPUR</td> </tr> <tr> <td>Bill Group Sorting</td> <td>C1-BGSRT</td> </tr> <tr> <td>Bill Group Derivation and Pricing Parameters</td> <td>C1-BGDVP</td> </tr> </tbody> </table> </div>	Upload Request	To Do Type	Adjustment	C1-ADJUP	Bill Cycle Update	C1-BCUUR	Billable Charge	C1-BCUR	Contract Rider Update	C1-CRUUR	Hold Request	C1-HLDUR	Refund Request	C1-REFUR	Write Off Request	C1-WOUR	Policy Reinstatement	C1-RPUR	Bill Group Sorting	C1-BGSRT	Bill Group Derivation and Pricing Parameters	C1-BGDVP	<p>Yes (Conditional)</p> <div style="border: 1px solid black; padding: 5px;"> <p><b>Note:</b> This field is required when the <b>Approval Required</b> check box is selected.</p> </div>
Upload Request	To Do Type																							
Adjustment	C1-ADJUP																							
Bill Cycle Update	C1-BCUUR																							
Billable Charge	C1-BCUR																							
Contract Rider Update	C1-CRUUR																							
Hold Request	C1-HLDUR																							
Refund Request	C1-REFUR																							
Write Off Request	C1-WOUR																							
Policy Reinstatement	C1-RPUR																							
Bill Group Sorting	C1-BGSRT																							
Bill Group Derivation and Pricing Parameters	C1-BGDVP																							

Field Name	Field Description	Mandatory (Yes or No)
Approval To Do Role	Used to indicate that users with the specified To Do role can only approve the upload request submitted for approval.	Yes (Conditional) <b>Note:</b> This field is required when the <b>Approval Required</b> check box is selected.
FK Reference	Used to indicate the FK Reference code to display the entity information. <b>Note:</b> The <b>Search</b>  icon appears corresponding to this field. On clicking the <b>Search</b> icon, the <b>Foreign Key Search</b> window appears. This field appears when <b>Upload Request Type</b> business object is selected.	No

In addition, this section contains the following fields in the grid:



**Note:** This field appears when **Adjustment Upload Request Type** business object is selected.

Field Name	Field Description	Mandatory (Yes or No)
Match Type	Used to indicate the match type using which you want to create adjustments when you upload a file using the upload request type. The valid values are: <ul style="list-style-type: none"> <li>Contract</li> <li>Contract Type</li> </ul>	Yes (Conditional) <b>Note:</b> This field is required when you select the <b>Adjustment Upload Request</b> option from the <b>Upload Request Business Object</b> list.
Algorithm	Used to attach an algorithm that will be triggered when you upload an adjustment data file. This algorithm determines the contract against which the adjustment must be created. <b>Note:</b> The <b>Search</b>  icon appears corresponding to this field. On clicking the <b>Search</b> icon, the <b>Algorithm Search</b> window appears.	Yes (Conditional) <b>Note:</b> This field is required when you select the match type from the respective field.

6. Enter the required details.

**Note:**

You can search for an algorithm by clicking the **Search**  icon corresponding to the respective field.

If you want to associate more than one match type with the upload request type, click the **Add**  icon and then specify the details. However, if you want to remove a match type from the upload request type, click the **Delete**  icon corresponding to the match type.

7. Define characteristics for the upload request type, if required.

8. Click **Save**.

The upload request type is defined.

**Related Topics**

For more information on...	See...
<b>Upload Request Type</b> screen	<a href="#">Upload Request Type</a> on page 1109
<b>Upload Request Type List</b> zone	<a href="#">Upload Request Type List</a> on page 1110
How to define characteristics for an upload request type	<a href="#">Defining Characteristics for an Upload Request Type</a> on page 1120

**Defining Characteristics for an Upload Request Type****Prerequisites**

To define characteristics for an upload request type, you should have:

- Characteristic types defined in the application (where the characteristic entity is set to Upload Request Type)

**Procedure**

To define characteristics for an upload request type:

1. Ensure that the **Characteristics** section is expanded when you are defining, editing, or copying an upload request type.

The **Characteristics** section contains the following fields:

Field Name	Field Description	Mandatory (Yes or No)
Characteristic Type	Used to indicate the characteristic type. <b>Note:</b> The list includes only those characteristic types where the characteristic entity is set to Upload Request Type.	Yes (Conditional) <b>Note:</b> This field is required when you are defining a characteristic for the upload request type.
Characteristic Value	Used to specify the value for the characteristic type. <b>Note:</b> On specifying the value for a predefined characteristic type, the description of the characteristic value appears corresponding to the <b>Characteristic Value</b> field.	Yes (Conditional) <b>Note:</b> This field is required when you are defining a characteristic for the upload request type.

2. Enter the required details.

**Note:** If you select a predefined characteristic type, the **Search**  icon appears corresponding to the **Characteristic Value** field. On clicking the **Search** icon, you can search for a predefined characteristic value.

3. If you want to define more than one characteristic for the upload request type, click the **Add**  icon and then repeat step 2.

**Note:** However, if you want to remove a characteristic from the upload request type, click the **Delete** () icon corresponding to the characteristic.

### Related Topics

For more information on...	See...
How to define an upload request type	<a href="#">Defining an Upload Request Type</a> on page 1114
How to edit an upload request type	<a href="#">Editing an Upload Request Type</a> on page 1121
How to copy an upload request type	<a href="#">Copying an Upload Request Type</a> on page 1125

## Editing an Upload Request Type

### Prerequisites

To edit an upload request type, you should have:

- Upload request business objects defined in the application
- Defer algorithm for adjustment is defined using the **C1-UPLDEFEVL** algorithm type
- Defer algorithm for upload is defined using the **C1-DEFERUPLD** algorithm type
- Algorithm defined using the **C1-MTCIALG** algorithm type when you want to create adjustment using the Contract match type
- Algorithm defined using the **C1-MTCTALG** algorithm type when you want to create adjustment using the Contract Type match type
- **C1-ADJUP** To Do type assigned to a To Do role whose users must receive To Do entries generated while submitting an adjustment upload request for approval
- **C1-UPLAPPENT** To Do type assigned to a To Do role whose users must receive To Do generated while submitting an upload request for approval

### Procedure

To edit an upload request type:

1. Click the **Admin** link in the **Application** toolbar.  
A list appears.
2. From the **Admin** menu, select **U** and then click **Upload Request Type**.  
A sub-menu appears.
3. In the **Upload Request Type List** zone, click the **Edit** () icon in the **Edit** column corresponding to the upload request type whose details you want to edit.

The **Upload Request Type** screen appears. It contains the following sections:



- **Main** – Used to specify basic details about the upload request type.
- **Characteristics** – Used to define characteristics for the upload request type.

The **Main** section contains the following fields:

Field Name	Field Description	Mandatory (Yes or No)
Upload Request Type	Displays the upload request type.	Not applicable
Upload Request Type Business Object	Indicates the upload request type business object used while defining the upload request type.	Not applicable

Field Name	Field Description	Mandatory (Yes or No)
Upload Request Business Object	Used to specify the business object that you want to use while creating the upload request.	Yes
Description	Used to specify the description for the upload request type.	Yes
Detailed Description	Used to specify additional information about the upload request type.	No
Status	Used to indicate the status of the upload request type. The valid values are: <ul style="list-style-type: none"> <li>• Active</li> <li>• Inactive</li> </ul>	Yes
File Size (KB)	Used to specify the maximum size of file (in kilobytes) that you can upload using the upload request type. If you upload a file which exceeds the maximum file size, the system will not allow you to upload the file. <div style="border: 1px solid black; padding: 5px; margin-top: 10px;"> <p><b>Note:</b> This field appears when the business object is <b>Adjustment Upload Request Type</b>.</p> </div>	Yes



Field Name	Field Description	Mandatory (Yes or No)
Defer Algorithm	<p>Used to attach an algorithm that will be triggered when you create entities (for example, adjustments) or approve the uploaded file (for example, adjustment data file). This algorithm checks whether the number of records in the uploaded file exceeds the online record process limit (defined in the Defer algorithm). If the number of records in the uploaded file does not exceed the online record process limit, the system creates the entities (for example, adjustments) in the real time (i.e. immediately). However, if the number of records in the uploaded file exceeds the online record process limit, the system creates the entities (for example, adjustments) in the deferred mode.</p> <div data-bbox="662 703 1177 1220" style="border: 1px solid black; padding: 5px;"> <p><b>Note:</b></p> <p>Deferred mode means in the background when the <b>Upload Request Periodic Monitor (C1-UPLRQ)</b> batch is invoked. You can configure the <b>Upload Request Periodic Monitor (C1-UPLRQ)</b> batch such that it is executed at regular intervals. When the <b>Upload Request Periodic Monitor (C1-UPLRQ)</b> batch is invoked, the system checks whether there are any upload requests in the <b>Deferred</b> status. If there is an upload request in the <b>Deferred</b> status, the system creates the entities (for example, adjustments).</p> <p>This field appears when the business object is <b>Adjustment Upload Request Type</b>.</p> </div>	Yes
Entity Business Object	<p>Used to indicate for creating Business Object of the entity using the upload request type.</p> <div data-bbox="662 1325 1177 1482" style="border: 1px solid black; padding: 5px;"> <p><b>Note:</b> The <b>Search</b>  icon appears corresponding to this field. On clicking the <b>Search</b> icon, the <b>Business Object Search</b> window appears.</p> </div>	No
Approval Required	<p>Used to indicate whether approval is required for a file which is uploaded using the upload request type.</p>	No
Approval To Do Type	<p>Used to indicate that To Do entry of the specified To Do type must be created when you submit the upload request for approval.</p> <div data-bbox="662 1734 1177 1892" style="border: 1px solid black; padding: 5px;"> <p><b>Note:</b> The <b>Search</b>  icon appears corresponding to this field. On clicking the <b>Search</b> icon, the <b>To Do Type Search</b> window appears.</p> </div>	<p>Yes (Conditional)</p> <div data-bbox="1193 1671 1463 1818" style="border: 1px solid black; padding: 5px;"> <p><b>Note:</b> This field is required when the <b>Approval Required</b> check box is selected.</p> </div>

Field Name	Field Description	Mandatory (Yes or No)
Approval To Do Role	Used to indicate that users with the specified To Do role can only approve the upload request submitted for approval.	Yes (Conditional) <b>Note:</b> This field is required when the <b>Approval Required</b> check box is selected.
FK Reference	Used to indicate the FK Reference code to display the entity information. <b>Note:</b> The <b>Search</b>  icon appears corresponding to this field. On clicking the <b>Search</b> icon, the <b>Foreign Key Search</b> window appears. This field appears when the business object is <b>Upload Request Type</b> .	No

In addition, this section contains the following fields in the grid:

**Note:** The below section appears when the business object is **Adjustment Upload Request Type**.



Field Name	Field Description	Mandatory (Yes or No)
Match Type	Used to indicate the match type using which you want to create adjustments when you upload a file using the upload request type. The valid values are: <ul style="list-style-type: none"> <li>Contract</li> <li>Contract Type</li> </ul>	Yes (Conditional) <b>Note:</b> This field is required when you select the <b>Adjustment Upload Request</b> option from the <b>Upload Request Business Object</b> list.
Algorithm	Used to attach an algorithm that will be triggered when you upload an adjustment data file. This algorithm determines the contract against which the adjustment must be created.	Yes (Conditional) <b>Note:</b> This field is required when you select the match type from the respective field.

**Tip:** Alternatively, you can click the **Edit** button in the **Upload Request Type** zone to edit the details of the upload request type.

#### 4. Modify the required details.

**Note:**

You can search for an algorithm by clicking the **Search**  icon corresponding to the respective field.

If you want to associate more than one match type with the upload request type, click the **Add**  icon and then specify the details. However, if you want to remove a match type from the upload request type, click the **Delete**  icon corresponding to the match type.

#### 5. Define, edit, or remove characteristics from the upload request type, if required.

## 6. Click **Save**.

The changes made to the upload request type are saved.

### Related Topics

For more information on...	See...
<b>Upload Request Type</b> screen	<a href="#">Upload Request Type</a> on page 1109
<b>Upload Request Type List</b> zone	<a href="#">Upload Request Type List</a> on page 1110
<b>Upload Request Type</b> zone	<a href="#">Upload Request Type</a> on page 1111
How to define characteristics for an upload request type	<a href="#">Defining Characteristics for an Upload Request Type</a> on page 1120

## Deleting an Upload Request Type

### Procedure

To delete an upload request type:

1. Click the **Admin** link in the **Application** toolbar.  
A list appears.
2. From the **Admin** menu, select **U** and then click **Upload Request Type**.  
A sub-menu appears.
3. In the **Upload Request Type List** zone, click the **Delete** (🗑) icon in the **Delete** column corresponding to the upload request type that you want to delete.

A message appears confirming whether you want to delete the upload request type.

**Note:** You can delete an upload request type only when you have not uploaded a file (i.e. created an upload request) using the upload request type.

**Tip:** Alternatively, you can click the **Delete** button in the **Upload Request Type** zone to delete the upload request type.

4. Click **OK**.

The upload request type is deleted.

### Related Topics

For more information on...	See...
<b>Upload Request Type</b> screen	<a href="#">Upload Request Type</a> on page 1109
<b>Upload Request Type List</b> zone	<a href="#">Upload Request Type List</a> on page 1110
<b>Upload Request Type</b> zone	<a href="#">Upload Request Type</a> on page 1111

## Copying an Upload Request Type

Instead of creating an upload request type from scratch, you can create a new upload request type using an existing upload request type. This is possible through copying an upload request type. On copying an upload request type, the details including the match types (only for adjustments) and characteristics are copied to the new upload request type. You can then edit the details, if required.

**Prerequisites**

To copy an upload request type, you should have:

- Upload request type (whose copy you want to create) defined in the application
- Upload request business objects defined in the application
- Defer algorithm defined using the **C1-UPLDEFEVL** algorithm type
- Defer algorithm for upload is defined using the **C1-DEFERUPLD** algorithm type
- Algorithm defined using the **C1-MTCIALG** algorithm type when you want to create adjustment using the Contract match type
- Algorithm defined using the **C1-MTCTALG** algorithm type when you want to create adjustment using the Contract Type match type
- **C1-ADJUP** To Do type assigned to a To Do role whose users must receive To Do entries generated while submitting an upload request for approval
- **C1-UPLAPPENT** To Do type assigned to a To Do role whose users must receive To Do generated while submitting an upload request for approval

**Procedure**

To copy an upload request type:

1. Click the **Admin** link in the **Application** toolbar.  
A list appears.
2. From the **Admin** menu, select **U** and then click **Upload Request Type**.  
A sub-menu appears.
3. In the **Upload Request Type List** zone, click the **Duplicate**  icon in the **Duplicate** column corresponding to the upload request type whose copy you want to create.

The **Upload Request Type** screen appears. It contains the following sections:

- **Main** – Used to specify basic details about the upload request type.
- **Characteristics** – Used to define characteristics for the upload request type.

The **Main** section contains the following fields:

Field Name	Field Description	Mandatory (Yes or No)
Upload Request Type	Used to specify the upload request type.	Yes
Upload Request Type Business Object	Indicates the upload request type business object used while defining the upload request type (whose copy you want to create).	Not applicable
Upload Request Business Object	Used to specify the business object that you want to use while creating the upload request.	Yes
Description	Used to specify the description for the upload request type.	Yes
Detailed Description	Used to specify additional information about the upload request type.	No

Field Name	Field Description	Mandatory (Yes or No)
Status	<p>Used to indicate the status of the upload request type. The valid values are:</p> <ul style="list-style-type: none"> <li>• Active</li> <li>• Inactive</li> </ul>	Yes
File Size (KB)	<p>Used to specify the maximum size of file (in kilobytes) that you can upload using the upload request type. If you upload a file which exceeds the maximum file size, the system will not allow you to upload the file.</p> <div style="border: 1px solid black; padding: 5px;"> <p><b>Note:</b> This field appears when the business object is <b>Adjustment Upload Request Type</b>.</p> </div>	Yes
Defer Algorithm	<p>Used to attach an algorithm that will be triggered when you create entities (for example, adjustments) or approve the uploaded file (for example, adjustment data file). This algorithm checks whether the number of records in the uploaded file exceeds the online record process limit (defined in the Defer algorithm). If the number of records in the uploaded file does not exceed the online record process limit, the system creates the entities (for example, adjustments) in the real time (i.e. immediately). However, if the number of records in the uploaded file exceeds the online record process limit, the system creates the entities (for example, adjustments) in the deferred mode.</p> <div style="border: 1px solid black; padding: 5px;"> <p><b>Note:</b></p> <p>Deferred mode means in the background when the <b>Upload Request Periodic Monitor (C1-UPLRQ)</b> batch is invoked. You can configure the <b>Upload Request Periodic Monitor (C1-UPLRQ)</b> batch such that it is executed at regular intervals. When the <b>Upload Request Periodic Monitor (C1-UPLRQ)</b> batch is invoked, the system checks whether there are any upload requests in the <b>Deferred</b> status. If there is an upload request in the <b>Deferred</b> status, the system creates the entities (for example, adjustments).</p> <p>This field appears when the business object is <b>Adjustment Upload Request Type</b>.</p> </div>	Yes

Field Name	Field Description	Mandatory (Yes or No)
Entity Business Object	Used to indicate to create the copy of Business Object of the entity using the upload request type.  <b>Note:</b> The <b>Search</b> (🔍) icon appears corresponding to this field. On clicking the <b>Search</b> icon, the <b>Business Object Search</b> window appears.  This field appears when the business object is <b>Upload Request Type</b> .	No
Approval Required	Used to indicate whether approval is required for a file which is uploaded using the upload request type.	No
Approval To Do Type	Used to indicate that To Do entry of the specified To Do type must be created when you submit the upload request for approval.  <b>Note:</b> The <b>Search</b> (🔍) icon appears corresponding to this field. On clicking the <b>Search</b> icon, the <b>To Do Type Search</b> window appears.	Yes (Conditional)  <b>Note:</b> This field is required when the <b>Approval Required</b> check box is selected.
Approval To Do Role	Used to indicate that users with the specified To Do role can only approve the upload request submitted for approval.	Yes (Conditional)  <b>Note:</b> This field is required when the <b>Approval Required</b> check box is selected.
FK Reference	Used to indicate the FK Reference code to display the entity information.  <b>Note:</b> The <b>Search</b> (🔍) icon appears corresponding to this field. On clicking the <b>Search</b> icon, the <b>Foreign Key Search</b> window appears.  This field appears when the business object is <b>Upload Request Type</b> .	No

In addition, this section contains the following fields in the grid:

**Note:** The below section appears when the business object is **Adjustment Upload Request Type**.



Field Name	Field Description	Mandatory (Yes or No)
Match Type	Used to indicate the match type using which you want to create adjustments when you upload a file using the upload request type. The valid values are: <ul style="list-style-type: none"> <li>Contract</li> <li>Contract Type</li> </ul>	Yes (Conditional) <b>Note:</b> This field is required when you select the <b>Adjustment Upload Request</b> option from the <b>Upload Request Business Object</b> list.
Algorithm	Used to attach an algorithm that will be triggered when you upload an adjustment data file. This algorithm determines the contract against which the adjustment must be created.	Yes (Conditional) <b>Note:</b> This field is required when you select the match type from the respective field.

**Tip:** Alternatively, you can click the **Duplicate** button in the **Upload Request Type** zone to create a copy of the upload request type.

- Enter the required details.

**Note:**

You can search for an algorithm by clicking the **Search**  icon corresponding to the respective field.

If you want to associate more than one match type with the upload request type, click the **Add**  icon and then specify the details. However, if you want to remove a match type from the upload request type, click the **Delete**  icon corresponding to the match type.

- Define, edit, or remove characteristics from the upload request type, if required.
- Click **Save**.

The new upload request type is defined.

### Related Topics

For more information on...	See...
<b>Upload Request Type</b> screen	<a href="#">Upload Request Type</a> on page 1109
<b>Upload Request Type List</b> zone	<a href="#">Upload Request Type List</a> on page 1110
<b>Upload Request Type</b> zone	<a href="#">Upload Request Type</a> on page 1111
How to define characteristics for an upload request type	<a href="#">Defining Characteristics for an Upload Request Type</a> on page 1120

## Mapping an Upload Request Type

### Prerequisites

To map an upload request type, you should have:

- Upload request type (whose columns you want to map with the CSV file) defined in the application
- Upload request business objects defined in the application

**Note:** Once an upload request type is used for creating an upload request, then mapping for the same cannot be edited. Duplicating the upload request type will not duplicate the mapping data. You have to add the mapping details manually after duplicating an upload request type.

### Procedure

To map an upload request type:

1. Click the **Admin** link in the **Application** toolbar.  
A list appears.
2. From the **Admin** menu, select **U** and then click **Upload Request Type**.  
A sub-menu appears.
3. In the **Upload Request Type List** zone, click the **Mapping**  icon in the **Mapping** column corresponding to the upload request type whose columns you want to map with the CSV file.

The **Upload Request Type Mapping** screen appears. It contains the following field:

**Note:** The **Mapping** icon is applicable only for upload request type created using **Upload Request Type (C1-UplRequestType)** business object, and it is not applicable for upload request type created using **Adjustment Upload Request Type (C1-AdjRequestType)** business object.

Field Name	Field Description	Mandatory (Yes or No)
Upload Request Type	Indicates the upload request type.	Not applicable

The **Upload Request Type Mapping** screen also contains the following columns:

Column Name	Column Description	Mandatory (Yes or No)
CSV Column Header	Used to specify the rows correspond to the columns in CSV file.	Yes (Conditional) <b>Note:</b> This column is required when you search the <b>Data Records</b> zone in the <b>Upload Request</b> screen.
Use for Searching	Used to indicate whether the defined <b>CSV Column Header</b> is searchable or not. <b>Note:</b> Upto 10 rows can be selected as searchable rows.	Yes (Conditional) <b>Note:</b> This column is required to be selected to be shown in the <b>Data Records</b> zone in the <b>Upload Request</b> screen
Sequence Number	Used to specify the sequence of the searchable fields. <b>Note:</b> Searchable rows should have sequence less than or equal to 10.	Yes (Conditional) <b>Note:</b> This column is required to be selected to be shown sequentially in the <b>Data Records</b> zone in the <b>Upload Request</b> screen

4. Enter the required details.



**Note:** If you want to add more than one column names mapped to the upload request type, click the **Add** (+) icon and then specify the details. However, if you want to remove a column name mapped to the upload request type, click the **Delete** (🗑️) icon corresponding to the column header.

5. Click **Save**.

The columns are mapped to the CSV files for upload request type.

### **Related Topics**

For more information on...	See...
<b>Upload Request Type</b> screen	<a href="#">Upload Request Type</a> on page 1109
<b>Upload Request Type List</b> zone	<a href="#">Upload Request Type List</a> on page 1110
<b>Upload Request Type</b> zone	<a href="#">Upload Request Type</a> on page 1111

## Viewing the Upload Request Type Details

### **Procedure**

To view the details of an upload request type:

1. Click the **Admin** link in the **Application** toolbar.  
A list appears.
2. From the **Admin** menu, select **U** and then click **Upload Request Type**.  
A sub-menu appears.
3. Click the **Search** option from the **Upload Request Type** sub-menu.  
The **Upload Request Type** screen appears.
4. In the **Upload Request Type List** zone, click the **Broadcast** (📡) icon corresponding to the upload request type whose details you want to view.  
The **Upload Request Type** zone appears.
5. View the details of the upload request type in the **Upload Request Type** zone.

### **Related Topics**

For more information on...	See...
<b>Upload Request Type</b> screen	<a href="#">Upload Request Type</a> on page 1109
<b>Upload Request Type List</b> zone	<a href="#">Upload Request Type List</a> on page 1110
<b>Upload Request Type</b> zone	<a href="#">Upload Request Type</a> on page 1111

## Upload Request (Used for Searching)

The **Upload Request** screen allows you to upload, validate and process the transaction data. Through this screen, you can navigate to the following screen:

- [Upload Request \(Used for Viewing\)](#) on page 1664

This screen consists of the following zone:

- [Search Upload Request](#) on page 1658

## Search Upload Request

The **Search Upload Request** zone allows you to search for a upload request using various search criteria. This zone contains the following two sections:

- **Search Criteria** – The **Search Criteria** section contains the following fields:

Field Name	Field Description	Mandatory (Yes or No)
Search By	Used to indicate whether you want to search for an upload request using <b>Request Details</b> .	Yes
Upload Date From	Used to search upload requests which are created from a particular date.	No
To	Used to search upload requests which are created till a particular date.	No
Status	Used to search upload requests with a particular status. The valid values are: <ul style="list-style-type: none"> <li>• Approval In Progress</li> <li>• Canceled</li> <li>• Deferred Processing</li> <li>• Draft</li> <li>• Processed</li> <li>• Rejected</li> <li>• Validated</li> </ul>	No
Upload Request Type	Used to search upload requests which are created using a particular upload request type.	No
User ID	Used to search upload requests which are created by a particular user.	No
Upload Request ID	Used to search a particular upload request.	No
File Name	Used to search a particular file name.	No

**Note:** You must specify at least one search criterion while searching for an upload request.

- **Search Results** – On clicking the **Search** button, the search results appear based on the specified search criteria. The **Search Results** section contains the following columns:

Column Name	Column Description
Upload Date	Displays the date and time when the upload request was created in the system.
Payment Request Information	Displays information about the upload request. <div style="border: 1px solid black; padding: 5px; margin-top: 5px;"> <p><b>Note:</b> It has a link. On clicking the link, the <b>Upload Request</b> screen appears where you can view the details of the respective upload request.</p> </div>

Column Name	Column Description
Status	Indicates the status of the upload request. The valid values are: <ul style="list-style-type: none"> <li>• Approval In Progress</li> <li>• Canceled</li> <li>• Deferred Processing</li> <li>• Draft</li> <li>• Processed</li> <li>• Rejected</li> <li>• Validated</li> </ul>
Upload Request Type	Displays the upload request type using which the upload request is created.
Entity Business Object	Displays the business object code of the entity.
File Name	Displays the uploaded file name.
Total Records	Displays the total number of records in the uploaded csv file.
Created By	Indicates the user who has created the upload request.

### **Related Topics**

For more information on...	See...
How to search for an upload request	<a href="#">Searching for an Upload Request</a> on page 1659
How to view the details of an upload request	<a href="#">Viewing the Upload Request Details</a> on page 1660
How to create an upload request	<a href="#">Creating an Upload Request</a> on page 1660
How to define characteristics for an upload request	<a href="#">Defining Characteristics for an Upload Request</a> on page 1663

## **Searching for an Upload Request**

### **Prerequisites**

To search for an upload request, you should have:

- Upload request types defined in the application

### **Procedure**

To search for an upload request:

1. Click the **Menu** link in the **Application** toolbar.  
A list appears.
2. From the **Main** menu, select **Tools** and then click **Upload Request**.  
A sub-menu appears.
3. Click the **Search** option from the **Upload Request** sub-menu.  
The **Upload Request** screen appears.
4. Enter the search criteria in the **Search Upload Request** zone.

**Note:** ORMB search engine supports wildcard search, where you can substitute the percentage (%) symbol as a stand in for any word or letter in a search criteria. You can use the ‘%’ wildcard character in all input fields except the date and ID fields. The ‘%’ wildcard character is suffixed automatically at the end of the partial search criteria. Therefore, you may or may not specify the wildcard character at the end of the partial search criteria. However, you have to prefix the wildcard character manually wherever required.

5. Click **Search**.

A list of upload requests that meet the search criteria appears in the **Search Results** section.

### Related Topics

For more information on...	See...
<b>Upload Request</b> screen	<a href="#">Upload Request (Used for Searching)</a> on page 1657
<b>Search Upload Request</b> zone	<a href="#">Search Upload Request</a> on page 1658

## Viewing the Upload Request Details

### Procedure

To view the details of an upload request:

1. Search for the upload request in the **Upload Request** screen.
2. In the **Search Results** section, click the link in the **Upload Request Information** column corresponding to the upload request whose details you want to view.

The **Upload Request** screen appears. It consists of the following tabs:

- **Main** – This tab contains the following two zones:
    - **Upload Request** – Displays the details of the upload request.
    - **Data Records** – Lists the details of data records uploaded in the csv file.
  - **Log** – This tab lists the complete trail of actions performed on the upload request.
3. View the details of the upload request in the **Upload Request** zone.
  4. View the data records in the csv file of the upload request in the **Data Records** zone.

### Related Topics

For more information on...	See...
How to search for an upload request	<a href="#">Searching for an Upload Request</a> on page 1659
<b>Upload Request</b> screen	<a href="#">Upload Request (Used for Viewing)</a> on page 1664
<b>Upload Request</b> zone	<a href="#">Upload Request</a> on page 1664
<b>Data Records</b> zone	<a href="#">Data Records</a> on page 1667

## Creating an Upload Request

### Prerequisites

To create an upload request, you should have:

- Upload request types defined in the application

### **Procedure**

To create an upload request:

1. Click the **Menu** link in the **Application** toolbar.  
A list appears.
2. From the **Main** menu, select **Tools** and then click **Upload Request**.  
A sub-menu appears.
3. Click the **Add** option from the **Upload Request** sub-menu.

The **Select Upload Request Type** screen appears. It contains the following field:

Field Name	Field Description	Mandatory (Yes or No)
Upload Request Type	<p>Used to indicate the upload request type using which you want to create the upload request.</p> <p><b>Note:</b> The following upload request types are shipped with the product:</p> <ul style="list-style-type: none"> <li>• ADJ_UPL_REQ_TYPE_APVL</li> <li>• ADJ_UPL_REQ_TYPE_WO_APVL</li> <li>• BC_UPL_REQ_TYPE</li> <li>• BILL_CYCLE_UPD_UPL_REQ_TYPE</li> <li>• BILL_LVL_UPL_REQ_TYPE</li> <li>• BILL_SRT_UPL_REQ_TYPE</li> <li>• HOLD_UPL_REQ_TYPE</li> <li>• REFUND_UPL_REQ_TYPE</li> <li>• REIN_UPL_REQ_TYPE</li> <li>• SA_RIDER_UPD_UPL_REQ_TYPE</li> <li>• WO_UPL_REQ_TYPE</li> </ul>	Yes

**Tip:** Alternatively, you can access the **Select Upload Request Type** screen by clicking the **Upload** button in the **Page Title** area of the **Upload Request** screen.

**Note:** The **Select Upload Request Type** screen appears only when there are multiple upload request types defined in the application. If there is only one upload request type defined in the application, the **{XXX} Upload Request** screen appears.

4. Select the required upload request type from the respective field.
5. Click **OK**.

The **{XXX} Upload Request** screen appears. Here, {XXX} changes depending on the upload request type that you have selected. It contains the following sections:

- **Main** – Used to specify basic details about the upload request.
- **Characteristics** – Used to define characteristics for the upload request.

The **Main** section contains the following fields:

Field Name	Field Description	Mandatory (Yes or No)
Upload Request Type	Indicates the upload request type using which the upload request will be created.	Not applicable
Parent Customer	<p>Used to indicate the person for whom you want to create the bill group sorting or bill group derivation and pricing parameters upload request.</p> <div style="border: 1px solid black; padding: 5px;"> <p><b>Note:</b> This field appears only when you are creating an upload request using an upload request type where the upload request business object is set to <b>C1-BillGrpSortUploadRequest</b> or <b>C1-BillLevelUploadRequest</b>. The system allows you to create a bill group sorting or bill group derivation and pricing parameters upload request for a person whose person type is set to <b>Parent Customer</b>. The <b>Search</b>  icon appears corresponding to this field. On clicking the <b>Search</b> icon, the <b>Person Search</b> window appears.</p> </div>	Yes
File Name	<p>Used to specify the name and path of the file that you want to upload.</p> <div style="border: 1px solid black; padding: 5px;"> <p><b>Note:</b> You can also click the <b>Browse</b> button corresponding to this field to browse to the location where the file is available in the system.</p> </div>	Yes
Replace Existing File	Used to indicate whether you want to replace any existing file in the system. You must select this check box when you want to upload the same file once again.	No
Comments	Used to specify additional information about the upload request.	No

6. Click the **Browse** button corresponding to the **File Name** field.  
The **Choose File to Upload** dialog box appears.
7. Browse to the location where the file that you want to upload is available in the system.
8. Click **Open**.  
The file name along with the path appears in the **File Name** field.
9. Select the **Replace Existing File** check box depending on whether you want to upload the same file once again in the system.
10. Define characteristics for the upload request, if required.

**11. Click Save.**

A message appears indicating the number of records which are successfully uploaded. Then, an upload request is created in the **Draft** status. If the required identifier (such as account ID, person ID, policy ID, or bill group ID) is available in the record, the status of the record is set to **Pending**. However, if the required identifier could not be derived from the system, the status of the record is set to **Invalid**.

**Related Topics**

For more information on...	See...
Upload Request screen	<a href="#">Upload Request (Used for Searching)</a> on page 1657
How to define characteristics for an upload request	<a href="#">Defining Characteristics for an Upload Request</a> on page 1663

**Defining Characteristics for an Upload Request****Prerequisites**

To define characteristics for an upload request, you should have:

- Characteristic types defined in the application (where the characteristic entity is set to **Upload Request**)

**Procedure**

To define characteristics for an upload request:

1. Ensure that the **Characteristics** section is expanded when you are defining or editing an upload request.

The **Characteristics** section contains the following fields in a grid:

Field Name	Field Description	Mandatory (Yes or No)
Effective Date	Used to specify the date from when the characteristic is effective for the upload request.	Yes (Conditional) <b>Note:</b> This field is required when you are defining a characteristic for the upload request.
Characteristic Type	Used to indicate the characteristic type. <b>Note:</b> The list includes only those characteristic types where the characteristic entity is set to <b>Upload Request</b> .	Yes (Conditional) <b>Note:</b> This field is required when you are defining a characteristic for the upload request.
Characteristic Value	Used to specify the value for the characteristic type. <b>Note:</b> On specifying the value for a predefined characteristic type, the description of the characteristic value appears corresponding to the <b>Characteristic Value</b> field.	Yes (Conditional) <b>Note:</b> This field is required when you are defining a characteristic for the upload request.

2. Enter the required details in the **Characteristics** section.

**Note:** If you select a predefined characteristic type, the **Search** () icon appears corresponding to the **Characteristic Value** field. On clicking the **Search** icon, you can search for a predefined characteristic value.

3. If you want to define more than one characteristic for the upload request, click the **Add** () icon and then repeat step 2.

**Note:** However, if you want to remove a characteristic from the upload request, click the **Delete** () icon corresponding to the characteristic.

### Related Topics

For more information on...	See...
How to create an upload request	<a href="#">Creating an Upload Request</a> on page 1660
How to edit an upload request	<a href="#">Editing an Upload Request</a> on page 1669

## Upload Request (Used for Viewing)

Once you create an upload request, the **Upload Request** screen allows you to:

- Edit the details of an upload request
- Delete an upload request
- View the details of an upload request
- Validate an upload request
- Cancel an upload request
- Submit an upload request
- Approve or reject an upload request
- View the data uploaded to a request
- View the log of an upload request
- Add a log entry for an upload request

This screen consists of the following tabs:

- **Main** – This tab contains the following two zones:
  - **Upload Request** – Displays the details of the upload request.
  - **Data Records** – Lists the data records of the upload request.
- **Log** – This tab lists the complete trail of actions performed on the upload request.

### Upload Request - Main

The **Main** tab contains the following zones:

- [Upload Request](#) on page 1664
- [Data Records](#) on page 1667

### Upload Request

The **Upload Request** zone displays the details of the upload request. This zone contains the following sections:

- **Main** – This section provides basic information about the upload request. It contains the following fields:



Field Name	Field Description
Upload Request Information	Displays information about the upload request.
Upload Request Type	Indicates the upload request type using which the upload request is created.  <b>Note:</b> It has a link. On clicking the link, the <b>Upload Request Type</b> screen appears where you can view the details of the upload request type.
Status	Indicates the status of the payment request. The valid values are: <ul style="list-style-type: none"> <li>• Approval In Progress</li> <li>• Approved</li> <li>• Cancelled</li> <li>• Deferred Processing</li> <li>• Draft</li> <li>• Processed</li> <li>• Rejected</li> <li>• Submitted</li> <li>• Validated</li> </ul>
File Name	Displays name of the uploaded file.

- **Statistics** – This section lists the statistics of records in the upload request. It contains the following fields:

Field Name	Field Description
Total Records	Displays total number of records in CSV file.
Valid Records	Displays the count of valid data records.
Error Records	Displays the count of data records in error status.
Pending Records	Displays the count of data records pending after successful derivation.
Invalid Records	Displays the count of data records after unsuccessful derivation.
Processed Records	Displays the count of data records after processing.

- **Characteristics** – This section lists the characteristics defined for the upload request. It contains the following columns:

Column Name	Column Description
Effective Date	Indicates the date from when the characteristic is effective for the upload request.
Characteristic Type	Indicates the characteristic type.
Characteristic Value	Displays the value of the characteristic type.

- **Record Actions** – This section contains the following buttons:

Column Name	Column Description
Edit	Used to edit the details of the upload request. <b>Note:</b> The <b>Edit</b> button appears when the upload request is in the <b>Draft</b> or <b>Validated</b> status.
Delete	Used to delete the upload request. <b>Note:</b> The <b>Delete</b> button appears only when the upload request is in the <b>Draft</b> status.
Validate	Used to validate the upload request. <b>Note:</b> The <b>Validate</b> button appears only when the upload request is in the <b>Draft</b> status.
Cancel	Used to cancel the upload request. <b>Note:</b> The <b>Cancel</b> button appears only when the upload request is in the <b>Validated</b> status.
Submit	Used to submit the upload request for approval. <b>Note:</b> The <b>Submit</b> button appears only when: <ul style="list-style-type: none"> <li>The upload request is in the <b>Validated</b> status.</li> <li>The <b>Approval Required</b> check box is selected in the upload request type using which the upload request is created.</li> </ul>
Approve	Used to approve the upload request. <b>Note:</b> The <b>Approve</b> button appears only when: <ul style="list-style-type: none"> <li>The upload request is in the <b>Approval In Progress</b> status.</li> <li>A user with the approval To Do role is reviewing the upload request.</li> </ul>
Reject	Used to reject the upload request. <b>Note:</b> The <b>Reject</b> button appears only when: <ul style="list-style-type: none"> <li>The upload request is in the <b>Approval In Progress</b> status.</li> <li>A user with the approval To Do role is reviewing the upload request.</li> </ul>

- **Record Information** – This section contains the following fields:

Field Name	Field Description
Business Object	Indicates the business object using which the upload request is created. In addition, a context menu appears corresponding to this field which helps in navigating to other screens in the application. <b>Note:</b> It has a link. On clicking the link, the <b>Business Object</b> screen appears where you can view the details of the respective business object.

Field Name	Field Description
Status Date/Time	Displays the date and time when the upload request status is updated
Create Date/Time	Displays the date and time when the upload request is created.

### Data Records

The **Data Records** zone lists the data records of the upload request. This zone contains the following two sections:

- **Search Criteria** – The **Search Criteria** section contains the following fields:

Field Name	Field Description	Mandatory (Yes or No)
Search Criteria 1, Search Criteria 2, .....,Search Criteria 10  <b>Note:</b> We have used generic field labels here. However, these labels will change depending on the mapping defined in the respective upload request type.	Used to search for data from the CSV file with respect to the field.	No
Record Status	Used to indicate whether you want to search data records for an upload request. The valid values are: <ul style="list-style-type: none"> <li>• Error</li> <li>• Invalid</li> <li>• Pending</li> <li>• Processed</li> <li>• Valid</li> </ul>	No

- **Search Results** – On clicking the **Search** button, the search results appear based on the specified search criteria. The **Search Results** section contains the following columns:

Column Name	Column Description
View	On clicking the <b>View</b>  icon, the <b>Data Record Details</b> window appears where you can view the details of the data records.
Search Result 1, Search Result 2, ....., Search Result 10  <b>Note:</b> We have used generic field labels here. However, these labels will change depending on the mapping defined in the respective upload request type.	Displays data from the CSV file.

Column Name	Column Description
Record Status	Indicates the status of the data record. The valid values are: <ul style="list-style-type: none"> <li>• Error</li> <li>• Invalid</li> <li>• Pending</li> <li>• Processed</li> <li>• Valid</li> </ul>
Message(s)	Displays message for the data record respective to it's status.
Entity ID	Displays entity ID of the upload request. <b>Note:</b> The entity ID is displayed only for data records with <b>Processed</b> status.
Entity Information	Displays entity information for the <b>FK Reference</b> selected in <b>Upload Request Type</b> screen. <b>Note:</b> The entity information is displayed only for data records with <b>Processed</b> status.

**Note:** By default the **Search Results** section displays data records for all the statuses though data is not added or selected to any of the fields and are searched through the **Search Criteria** section.

### Related Topics

For more information on...	See...
How to view details against each data record.	<a href="#">Viewing the Data Record Details</a> on page 1680

## Upload Request - Log

The **Log** tab contains the following zone:

- [Upload Request Log](#) on page 1668

### Upload Request Log

The **Upload Request Log** zone on the **Upload Request** screen lists the complete trail of actions performed on the upload request. This zone contains the following columns:

Column Name	Column Description
Date/Time	Displays the date and time when the action was performed on the upload request.
Details	Displays the details about the action performed on the upload request.
User	Indicates the user who has performed the action on the upload request.
Log Type	Indicates the type of log.
Related Object	Indicates the object or entity which is generated when the action is performed on the upload request.
Status Reason	Displays the status reason of action performed on the upload request.

**Note:** You can manually add a log entry for the upload request by clicking the **Add Log Entry** link in the upper right corner of the **Upload Request Log** zone.

The **Add Upload Request Log** window appears. Enter **Log Details** and click **Save**. The upload request log is added.

### **Related Topics**

<b>For more information on...</b>	<b>See...</b>
How to view the log of an upload request	<a href="#">Viewing the Log of an Upload Request</a> on page 1681
How to add the log for an upload request	<a href="#">Adding a Log Entry for an Upload Request</a> on page 1682

## **Editing an Upload Request**

### **Procedure**

To edit an upload request:

1. Search for the upload request in the **Upload Request** screen.
2. In the **Search Results** section, click the link in the **Upload Request Information** column corresponding to the upload request whose details you want to edit.

The **Upload Request** screen appears.

3. Click the **Edit** button in the **Upload Request** zone.

**Note:** The **Edit** button appears only when the upload request is in the **Draft** or **Validated** status.

The entity **Upload Request** screen appears. It contains the following sections:

- **Main** – Used to specify basic details about the upload request. This section contains the following fields:

<b>Field Name</b>	<b>Field Description</b>	<b>Mandatory (Yes or No)</b>
Upload Request Type	Displays the upload request type using which the upload request is created.	Not applicable
File Name	Displays name of the uploaded CSV file.	Not applicable
Comments	Used to indicate the comments for upload request.	No

- **Characteristics** – Used to define characteristics for the upload request. This section contains the following fields:

<b>Field Name</b>	<b>Field Description</b>	<b>Mandatory (Yes or No)</b>
Effective Date	Used to specify the date from when the characteristic is effective for the upload request.	Yes (Conditional) <b>Note:</b> This field is required when you are defining a characteristic for the upload request.
Characteristic Type	Used to indicate the characteristic type. <b>Note:</b> The list includes only those characteristic types where the characteristic entity is set to <b>Upload Request</b> .	Yes (Conditional) <b>Note:</b> This field is required when you are defining a characteristic for the Upload request.

Field Name	Field Description	Mandatory (Yes or No)
Characteristic Value	Used to specify the value for the characteristic type.  <b>Note:</b> On specifying the value for a predefined characteristic type, the description of the characteristic value appears corresponding to the <b>Characteristic Value</b> field.	Yes (Conditional)  <b>Note:</b> This field is required when you are defining a characteristic for the Upload request.

4. Modify the details of the upload request, if required.
5. Define, edit, or remove characteristics from the upload request, if required.
6. Click **Save**.

The changes made to the upload request are saved.

### Related Topics

For more information on...	See...
How to search for an upload request	<a href="#">Searching for an Upload Request</a> on page 1659
<b>Upload Request</b> screen	<a href="#">Upload Request (Used for Viewing)</a> on page 1664
<b>Upload Request</b> zone	<a href="#">Upload Request</a> on page 1664
How to define characteristics for an upload request	<a href="#">Defining Characteristics for an Upload Request</a> on page 1663

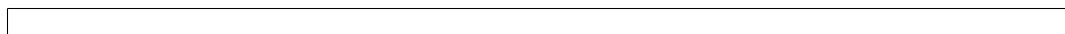

## Deleting an Upload Request

### Procedure

To delete an upload request:

1. Search for the upload request in the **Upload Request** screen.
2. In the **Search Results** section, click the link in the **Upload Request Information** column corresponding to the upload request that you want to delete.

The **Upload Request** screen appears.

3. Click the **Delete** button in the **Upload Request** zone.

A message appears confirming whether you want to delete the upload request.

**Note:** The **Delete** button appears only when the upload request is in the **Draft** status.

4. Click **OK**.

The upload request is deleted.

### Related Topics

For more information on...	See...
How to search for an upload request	<a href="#">Searching for an Upload Request</a> on page 1659
<b>Upload Request</b> screen	<a href="#">Upload Request (Used for Viewing)</a> on page 1664

For more information on...	See...
<b>Upload Request</b> zone	<a href="#">Upload Request</a> on page 1664

## Validating an Upload Request

### Prerequisites

To validate an upload request, you should have:

- Upload Request Types defined in the request.

### Procedure

To validate an upload request:

1. Search for the upload request in the **Upload Request** screen.
2. In the **Search Results** section, click the link in the **Upload Request Information** column corresponding to the upload request that you want to validate.

The **Upload Request** screen appears.

3. Click the **Validate** button in the **Upload Request** zone.

**Note:** The **Validate** button appears only when the upload request is in the **Draft** status.

For more information about the **Upload Request Periodic Monitor (C1-UPLRQ)** batch, refer to Oracle Revenue Management and Billing Batch Guide.

The status of the upload request is changed to **Validated**.

### Related Topics

For more information on...	See...
How to search for an upload request	<a href="#">Searching for an Upload Request</a> on page 1659
<b>Upload Request</b> screen	<a href="#">Upload Request (Used for Viewing)</a> on page 1664
<b>Upload Request</b> zone	<a href="#">Upload Request</a> on page 1664

## Cancelling an Upload Request

### Prerequisites

To cancel an upload request, you should have:

- Cancellation reasons defined in the application

**Note:** While cancelling an upload request, you need to specify the reason why you want to cancel the upload request. You can select the appropriate cancellation reason only when you have defined the reasons for the **Canceled** status of the **C1-UplRequestType** business object in the **Status Reason** screen.

### Procedure

To cancel an upload request:

1. Search for the upload request in the **Upload Request** screen.

- In the **Search Results** section, click the link in the **Upload Request Information** column corresponding to the upload request that you want to cancel.

The **Upload Request** screen appears.

- Click the **Cancel** button in the **Upload Request** zone.

The **Cancel Reason** window appears. It contains following fields:

Field Name	Field Description	Mandatory (Yes or No)
Cancel Reason	Used to indicate the reason why you want to cancel the upload request.	Yes
Comments	Used to specify additional information while cancelling the upload request.	No

**Note:** The **Cancel** button appears only when the upload request is in the **Validated** status.

- Select the cancellation reason from the **Cancel Reason** list.
- Click **Save**.

The status of the upload request is changed to **Canceled**.

### **Related Topics**

For more information on...	See...
How to search for an upload request	<a href="#">Searching for an Upload Request</a> on page 1659
<b>Upload Request</b> screen	<a href="#">Upload Request (Used for Viewing)</a> on page 1664
<b>Upload Request</b> zone	<a href="#">Upload Request</a> on page 1664

## **Submitting an Upload Request**

### **Procedure**

To submit an upload request:

- Search for the upload request in the **Upload Request** screen.
- In the **Search Results** section, click the link in the **Upload Request Information** column corresponding to the upload request that you want to submit.

The **Upload Request** screen appears.

- Click the **Submit** button in the **Upload Request** zone.

The system behaves in the following manner:



If...	Then...																				
<p>The <b>Approval Required</b> check box is selected in the upload request type using which the upload request is created</p>	<p>A To Do of the specified To Do type is created and sent to the approver for approval. The following table lists the To Do type using which the To Do is created for the different upload requests:</p> <table border="1" data-bbox="873 359 1468 894"> <thead> <tr> <th data-bbox="873 359 1166 411">Upload Request</th> <th data-bbox="1166 359 1468 411">To Do Type</th> </tr> </thead> <tbody> <tr> <td data-bbox="873 411 1166 464">Bill Cycle Update</td> <td data-bbox="1166 411 1468 464">C1-BCUUR</td> </tr> <tr> <td data-bbox="873 464 1166 516">Billable Charge</td> <td data-bbox="1166 464 1468 516">C1-BCUR</td> </tr> <tr> <td data-bbox="873 516 1166 569">Contract Rider Update</td> <td data-bbox="1166 516 1468 569">C1-CRUUR</td> </tr> <tr> <td data-bbox="873 569 1166 621">Hold Request</td> <td data-bbox="1166 569 1468 621">C1-HLDUR</td> </tr> <tr> <td data-bbox="873 621 1166 674">Refund Request</td> <td data-bbox="1166 621 1468 674">C1-REFUR</td> </tr> <tr> <td data-bbox="873 674 1166 726">Write Off Request</td> <td data-bbox="1166 674 1468 726">C1-WOUR</td> </tr> <tr> <td data-bbox="873 726 1166 779">Policy Reinstatement</td> <td data-bbox="1166 726 1468 779">C1-RPUR</td> </tr> <tr> <td data-bbox="873 779 1166 831">Bill Group Sorting</td> <td data-bbox="1166 779 1468 831">C1-BGSRT</td> </tr> <tr> <td data-bbox="873 831 1166 894">Bill Group Derivation and Pricing Parameters</td> <td data-bbox="1166 831 1468 894">C1-BGDVP</td> </tr> </tbody> </table> <p>In addition, the status of the upload request is changed to <b>Approval In Progress</b>.</p>	Upload Request	To Do Type	Bill Cycle Update	C1-BCUUR	Billable Charge	C1-BCUR	Contract Rider Update	C1-CRUUR	Hold Request	C1-HLDUR	Refund Request	C1-REFUR	Write Off Request	C1-WOUR	Policy Reinstatement	C1-RPUR	Bill Group Sorting	C1-BGSRT	Bill Group Derivation and Pricing Parameters	C1-BGDVP
Upload Request	To Do Type																				
Bill Cycle Update	C1-BCUUR																				
Billable Charge	C1-BCUR																				
Contract Rider Update	C1-CRUUR																				
Hold Request	C1-HLDUR																				
Refund Request	C1-REFUR																				
Write Off Request	C1-WOUR																				
Policy Reinstatement	C1-RPUR																				
Bill Group Sorting	C1-BGSRT																				
Bill Group Derivation and Pricing Parameters	C1-BGDVP																				

If...	Then...																				
<p>The <b>Approval Required</b> check box is not selected in the upload request type using which the upload request is created and the number of valid records in the upload request does not exceed the online record process limit defined in the <b>C1-DEFERUPLD</b> algorithm.</p>	<p>The following table lists the behavior for the different upload requests:</p>																				
	<table border="1"> <thead> <tr> <th data-bbox="873 300 1122 342">Upload Request</th> <th data-bbox="1130 300 1464 342">Behaviour</th> </tr> </thead> <tbody> <tr> <td data-bbox="873 342 1122 426">Bill Cycle Update</td> <td data-bbox="1130 342 1464 426">The bill cycle information is updated for the accounts.</td> </tr> <tr> <td data-bbox="873 426 1122 510">Billable Charge</td> <td data-bbox="1130 426 1464 510">The billable charges are created.</td> </tr> <tr> <td data-bbox="873 510 1122 621">Contract Rider Update</td> <td data-bbox="1130 510 1464 621">The contract rider information is updated for the contracts.</td> </tr> <tr> <td data-bbox="873 621 1122 705">Hold Request</td> <td data-bbox="1130 621 1464 705">The hold requests are created.</td> </tr> <tr> <td data-bbox="873 705 1122 789">Refund Request</td> <td data-bbox="1130 705 1464 789">The refund requests are created.</td> </tr> <tr> <td data-bbox="873 789 1122 873">Write Off Request</td> <td data-bbox="1130 789 1464 873">The write off requests are created.</td> </tr> <tr> <td data-bbox="873 873 1122 1146">Policy Reinstatement</td> <td data-bbox="1130 873 1464 1146">The policies are reinstated and the status of the policies is changed to the one defined in the <b>Policy Status after Processing Reinstatement Upload Request</b> parameter of the <b>C1-REN-VALID</b> algorithm.</td> </tr> <tr> <td data-bbox="873 1146 1122 1230">Bill Group Sorting</td> <td data-bbox="1130 1146 1464 1230">The sort ID is defined for the respective bill group.</td> </tr> <tr> <td data-bbox="873 1230 1122 1373">Bill Group Derivation and Pricing Parameters</td> <td data-bbox="1130 1230 1464 1373">The derivation and pricing parameters are defined for the respective bill group and sort ID combination.</td> </tr> </tbody> </table>	Upload Request	Behaviour	Bill Cycle Update	The bill cycle information is updated for the accounts.	Billable Charge	The billable charges are created.	Contract Rider Update	The contract rider information is updated for the contracts.	Hold Request	The hold requests are created.	Refund Request	The refund requests are created.	Write Off Request	The write off requests are created.	Policy Reinstatement	The policies are reinstated and the status of the policies is changed to the one defined in the <b>Policy Status after Processing Reinstatement Upload Request</b> parameter of the <b>C1-REN-VALID</b> algorithm.	Bill Group Sorting	The sort ID is defined for the respective bill group.	Bill Group Derivation and Pricing Parameters	The derivation and pricing parameters are defined for the respective bill group and sort ID combination.
	Upload Request	Behaviour																			
	Bill Cycle Update	The bill cycle information is updated for the accounts.																			
	Billable Charge	The billable charges are created.																			
	Contract Rider Update	The contract rider information is updated for the contracts.																			
	Hold Request	The hold requests are created.																			
	Refund Request	The refund requests are created.																			
	Write Off Request	The write off requests are created.																			
	Policy Reinstatement	The policies are reinstated and the status of the policies is changed to the one defined in the <b>Policy Status after Processing Reinstatement Upload Request</b> parameter of the <b>C1-REN-VALID</b> algorithm.																			
Bill Group Sorting	The sort ID is defined for the respective bill group.																				
Bill Group Derivation and Pricing Parameters	The derivation and pricing parameters are defined for the respective bill group and sort ID combination.																				
<p>In addition, the status of the upload request is changed to <b>Processed</b>.</p>																					

If...	Then...																				
<p>The <b>Approval Required</b> check box is not selected in the upload request type using which the upload request is created and the number of valid records in the upload request exceeds the online record process limit defined in the <b>C1-DEFERUPLD</b> algorithm</p>	<p>The system changes the status of the upload request to <b>Deferred Processing</b>. When the <b>Upload Request Periodic Monitor (C1-UPLRQ)</b> batch is invoked, the system checks whether there are any upload requests in the <b>Deferred Processing</b> status. If there is an upload request in the <b>Deferred Processing</b> status, the system behaves in the following manner for the different upload requests:</p> <table border="1" data-bbox="873 485 1468 1528"> <thead> <tr> <th data-bbox="881 495 1122 537">Upload Request</th> <th data-bbox="1130 495 1468 537">Behaviour</th> </tr> </thead> <tbody> <tr> <td data-bbox="881 541 1122 621">Bill Cycle Update</td> <td data-bbox="1130 541 1468 621">The bill cycle information is updated for the accounts.</td> </tr> <tr> <td data-bbox="881 625 1122 705">Billable Charge</td> <td data-bbox="1130 625 1468 705">The billable charges are created.</td> </tr> <tr> <td data-bbox="881 709 1122 810">Contract Rider Update</td> <td data-bbox="1130 709 1468 810">The contract rider information is updated for the contracts.</td> </tr> <tr> <td data-bbox="881 814 1122 863">Hold Request</td> <td data-bbox="1130 814 1468 863">The hold requests are created.</td> </tr> <tr> <td data-bbox="881 867 1122 947">Refund Request</td> <td data-bbox="1130 867 1468 947">The refund requests are created.</td> </tr> <tr> <td data-bbox="881 951 1122 1031">Write Off Request</td> <td data-bbox="1130 951 1468 1031">The write off requests are created.</td> </tr> <tr> <td data-bbox="881 1035 1122 1304">Policy Reinstatement</td> <td data-bbox="1130 1035 1468 1304">The policies are reinstated and the status of the policies is changed to the one defined in the <b>Policy Status after Processing Reinstatement Upload Request</b> parameter of the <b>C1-REN-VALID</b> algorithm.</td> </tr> <tr> <td data-bbox="881 1308 1122 1388">Bill Group Sorting</td> <td data-bbox="1130 1308 1468 1388">The sort ID is defined for the respective bill group.</td> </tr> <tr> <td data-bbox="881 1392 1122 1524">Bill Group Derivation and Pricing Parameters</td> <td data-bbox="1130 1392 1468 1524">The derivation and pricing parameters are defined for the respective bill group and sort ID combination.</td> </tr> </tbody> </table> <p>In addition, the status of the upload request is changed to <b>Processed</b>.</p>	Upload Request	Behaviour	Bill Cycle Update	The bill cycle information is updated for the accounts.	Billable Charge	The billable charges are created.	Contract Rider Update	The contract rider information is updated for the contracts.	Hold Request	The hold requests are created.	Refund Request	The refund requests are created.	Write Off Request	The write off requests are created.	Policy Reinstatement	The policies are reinstated and the status of the policies is changed to the one defined in the <b>Policy Status after Processing Reinstatement Upload Request</b> parameter of the <b>C1-REN-VALID</b> algorithm.	Bill Group Sorting	The sort ID is defined for the respective bill group.	Bill Group Derivation and Pricing Parameters	The derivation and pricing parameters are defined for the respective bill group and sort ID combination.
Upload Request	Behaviour																				
Bill Cycle Update	The bill cycle information is updated for the accounts.																				
Billable Charge	The billable charges are created.																				
Contract Rider Update	The contract rider information is updated for the contracts.																				
Hold Request	The hold requests are created.																				
Refund Request	The refund requests are created.																				
Write Off Request	The write off requests are created.																				
Policy Reinstatement	The policies are reinstated and the status of the policies is changed to the one defined in the <b>Policy Status after Processing Reinstatement Upload Request</b> parameter of the <b>C1-REN-VALID</b> algorithm.																				
Bill Group Sorting	The sort ID is defined for the respective bill group.																				
Bill Group Derivation and Pricing Parameters	The derivation and pricing parameters are defined for the respective bill group and sort ID combination.																				

**Note:**

The **Submit** button appears only when the upload request is in the **Validated** status.

**Related Topics**

For more information on...	See...
Upload Request screen	<a href="#">Upload Request (Used for Viewing)</a> on page 1664

For more information on...	See...
<b>Upload Request</b> zone	<a href="#">Upload Request</a> on page 1664
How to search for an upload request	<a href="#">Searching for an Upload Request</a> on page 1659

## Approving an Upload Request

You can view the number of upload requests which are pending for approval in the **Upload Request** screen. The approver can review, and accordingly approve or reject the upload request based on the observations.

**Note:** The system will not allow you to approve or reject an upload request submitted by you.

### Procedure

To approve an upload request:

1. Do either of the following:

If you want to...	Then...
Approve a upload request through the <b>Upload Request</b> screen	<ol style="list-style-type: none"> <li>1. Search for the upload request in the <b>Upload Request</b> screen.</li> <li>2. In the <b>Search Results</b> section, click the link in the <b>Upload Request Information</b> column corresponding to the upload request which you want to review.</li> </ol>
Approve a upload request from the <b>To Do List</b> screen	<ol style="list-style-type: none"> <li>1. Click the <b>Menu</b> link in the <b>Application</b> toolbar. A list appears.</li> <li>2. From the <b>Main</b> menu, select <b>To Do</b> and then click <b>To Do List</b>. The <b>To Do Type for User Search</b> window appears.</li> <li>3. Enter the required To Do type in the respective field.</li> <li>4. Click the <b>Search</b> button corresponding to the <b>To Do Type</b> field. The <b>To Do List</b> screen appears.</li> <li>5. Select the <b>Open</b> option from the <b>Filter by</b> list to view all unassigned To Dos.</li> <li>6. Click the link in the <b>Message</b> column corresponding to the To Do of the upload request that you want to review.</li> </ol>

The **Upload Request** screen appears.

2. Review the upload request details.
3. Click the **Approve** button in the **Upload Request** zone.

The system behaves in the following manner:

If...	Then...																				
<p>The number of valid records in the upload request does not exceed the online record process limit defined in the <b>C1-DEFERUPLD</b> algorithm</p>	<p>The following table lists the behavior for the different upload requests:</p> <table border="1" data-bbox="889 348 1463 1455"> <thead> <tr> <th data-bbox="889 348 1133 396">Upload Request</th> <th data-bbox="1133 348 1463 396">Behavior</th> </tr> </thead> <tbody> <tr> <td data-bbox="889 396 1133 478">Bill Cycle Update</td> <td data-bbox="1133 396 1463 478">The bill cycle information is updated for the accounts.</td> </tr> <tr> <td data-bbox="889 478 1133 560">Billable Charge</td> <td data-bbox="1133 478 1463 560">The billable charges are created.</td> </tr> <tr> <td data-bbox="889 560 1133 674">Contract Rider Update</td> <td data-bbox="1133 560 1463 674">The contract rider information is updated for the contracts.</td> </tr> <tr> <td data-bbox="889 674 1133 756">Hold Request</td> <td data-bbox="1133 674 1463 756">The hold requests are created.</td> </tr> <tr> <td data-bbox="889 756 1133 837">Refund Request</td> <td data-bbox="1133 756 1463 837">The refund requests are created.</td> </tr> <tr> <td data-bbox="889 837 1133 919">Write Off Request</td> <td data-bbox="1133 837 1463 919">The write off requests are created.</td> </tr> <tr> <td data-bbox="889 919 1133 1224">Policy Reinstatement</td> <td data-bbox="1133 919 1463 1224">The policies are reinstated and the status of the policies is changed to the one defined in the <b>Policy Status after Processing Reinstatement Upload Request</b> parameter of the <b>C1-REN-VALID</b> algorithm.</td> </tr> <tr> <td data-bbox="889 1224 1133 1306">Bill Group Sorting</td> <td data-bbox="1133 1224 1463 1306">The sort ID is defined for the respective bill group.</td> </tr> <tr> <td data-bbox="889 1306 1133 1455">Bill Group Derivation and Pricing Parameters</td> <td data-bbox="1133 1306 1463 1455">The derivation and pricing parameters are defined for the respective bill group and sort ID combination.</td> </tr> </tbody> </table> <p>In addition, the status of the upload request is changed to <b>Processed</b>.</p>	Upload Request	Behavior	Bill Cycle Update	The bill cycle information is updated for the accounts.	Billable Charge	The billable charges are created.	Contract Rider Update	The contract rider information is updated for the contracts.	Hold Request	The hold requests are created.	Refund Request	The refund requests are created.	Write Off Request	The write off requests are created.	Policy Reinstatement	The policies are reinstated and the status of the policies is changed to the one defined in the <b>Policy Status after Processing Reinstatement Upload Request</b> parameter of the <b>C1-REN-VALID</b> algorithm.	Bill Group Sorting	The sort ID is defined for the respective bill group.	Bill Group Derivation and Pricing Parameters	The derivation and pricing parameters are defined for the respective bill group and sort ID combination.
Upload Request	Behavior																				
Bill Cycle Update	The bill cycle information is updated for the accounts.																				
Billable Charge	The billable charges are created.																				
Contract Rider Update	The contract rider information is updated for the contracts.																				
Hold Request	The hold requests are created.																				
Refund Request	The refund requests are created.																				
Write Off Request	The write off requests are created.																				
Policy Reinstatement	The policies are reinstated and the status of the policies is changed to the one defined in the <b>Policy Status after Processing Reinstatement Upload Request</b> parameter of the <b>C1-REN-VALID</b> algorithm.																				
Bill Group Sorting	The sort ID is defined for the respective bill group.																				
Bill Group Derivation and Pricing Parameters	The derivation and pricing parameters are defined for the respective bill group and sort ID combination.																				

If...	Then...																				
<p>The number of valid records in the upload request exceeds the online record process limit defined in the <b>C1-DEFERUPLD</b> algorithm</p>	<p>The system changes the status of the upload request to <b>Deferred Processing</b>. When the <b>Upload Request Periodic Monitor (C1-UPLRQ)</b> batch is invoked, the system checks whether there are any upload requests in the <b>Deferred Processing</b> status. If there is an upload request in the <b>Deferred Processing</b> status, the system behaves in the following manner for the different upload requests:</p> <table border="1" data-bbox="889 485 1461 1591"> <thead> <tr> <th data-bbox="889 485 1133 535">Upload Request</th> <th data-bbox="1133 485 1461 535">Behavior</th> </tr> </thead> <tbody> <tr> <td data-bbox="889 541 1133 617">Bill Cycle Update</td> <td data-bbox="1133 541 1461 617">The bill cycle information is updated for the accounts.</td> </tr> <tr> <td data-bbox="889 623 1133 699">Billable Charge</td> <td data-bbox="1133 623 1461 699">The billable charges are created.</td> </tr> <tr> <td data-bbox="889 705 1133 810">Contract Rider Update</td> <td data-bbox="1133 705 1461 810">The contract rider information is updated for the contracts.</td> </tr> <tr> <td data-bbox="889 816 1133 892">Hold Request</td> <td data-bbox="1133 816 1461 892">The hold requests are created.</td> </tr> <tr> <td data-bbox="889 898 1133 974">Refund Request</td> <td data-bbox="1133 898 1461 974">The refund requests are created.</td> </tr> <tr> <td data-bbox="889 980 1133 1056">Write Off Request</td> <td data-bbox="1133 980 1461 1056">The write off requests are created.</td> </tr> <tr> <td data-bbox="889 1062 1133 1360">Policy Reinstatement</td> <td data-bbox="1133 1062 1461 1360">The policies are reinstated and the status of the policies is changed to the one defined in the <b>Policy Status after Processing Reinstatement Upload Request</b> parameter of the <b>C1-REN-VALID</b> algorithm.</td> </tr> <tr> <td data-bbox="889 1367 1133 1442">Bill Group Sorting</td> <td data-bbox="1133 1367 1461 1442">The sort ID is defined for the respective bill group.</td> </tr> <tr> <td data-bbox="889 1449 1133 1591">Bill Group Derivation and Pricing Parameters</td> <td data-bbox="1133 1449 1461 1591">The derivation and pricing parameters are defined for the respective bill group and sort ID combination.</td> </tr> </tbody> </table> <p>In addition, the status of the upload request is changed to <b>Processed</b>.</p>	Upload Request	Behavior	Bill Cycle Update	The bill cycle information is updated for the accounts.	Billable Charge	The billable charges are created.	Contract Rider Update	The contract rider information is updated for the contracts.	Hold Request	The hold requests are created.	Refund Request	The refund requests are created.	Write Off Request	The write off requests are created.	Policy Reinstatement	The policies are reinstated and the status of the policies is changed to the one defined in the <b>Policy Status after Processing Reinstatement Upload Request</b> parameter of the <b>C1-REN-VALID</b> algorithm.	Bill Group Sorting	The sort ID is defined for the respective bill group.	Bill Group Derivation and Pricing Parameters	The derivation and pricing parameters are defined for the respective bill group and sort ID combination.
Upload Request	Behavior																				
Bill Cycle Update	The bill cycle information is updated for the accounts.																				
Billable Charge	The billable charges are created.																				
Contract Rider Update	The contract rider information is updated for the contracts.																				
Hold Request	The hold requests are created.																				
Refund Request	The refund requests are created.																				
Write Off Request	The write off requests are created.																				
Policy Reinstatement	The policies are reinstated and the status of the policies is changed to the one defined in the <b>Policy Status after Processing Reinstatement Upload Request</b> parameter of the <b>C1-REN-VALID</b> algorithm.																				
Bill Group Sorting	The sort ID is defined for the respective bill group.																				
Bill Group Derivation and Pricing Parameters	The derivation and pricing parameters are defined for the respective bill group and sort ID combination.																				

**Note:** The **Approve** button appears only when:

- The upload request is in the **Approval In Progress** status.
- A user with the approval To Do role is reviewing the upload request.

### **Related Topics**

<b>For more information on...</b>	<b>See...</b>
<b>Upload Request</b> screen	<a href="#">Upload Request (Used for Viewing)</a> on page 1664
<b>Upload Request</b> zone	<a href="#">Upload Request</a> on page 1664
How to search for an upload request	<a href="#">Searching for an Upload Request</a> on page 1659

## Rejecting an Upload Request

### Prerequisites

To reject an upload request, you should have:

- Rejection reasons defined in the application

### **Note:**

While rejecting an upload request, you need to specify the reason why you want to reject the upload request. You can select the appropriate rejection reason only when you have defined the reasons for the **Rejected** status of the **C1-UplRequestType** business object in the **Status Reason** screen.

The system will not allow you to approve or reject an upload request submitted by you.

### Procedure

To reject an upload request:

1. Do either of the following:

<b>If you want to</b>	<b>Then</b>
Reject an upload request through the <b>Upload Request</b> screen	<ol style="list-style-type: none"> <li>1. Search for the upload request in the <b>Upload Request</b> screen.</li> <li>2. In the <b>Search Results</b> section, click the link in the <b>Upload Request Information</b> column corresponding to the upload request which you want to review.</li> </ol>
Reject an upload request from the <b>To Do List</b> screen	<ol style="list-style-type: none"> <li>1. Click the <b>Menu</b> link in the <b>Application</b> toolbar. A list appears.</li> <li>2. From the <b>Main</b> menu, select <b>To Do</b> and then click <b>To Do List</b>. The <b>To Do Type for User Search</b> window appears.</li> <li>3. Enter the required To Do type in the respective field.</li> <li>4. Click the <b>Search</b> button corresponding to the <b>To Do Type</b> field. The <b>To Do List</b> screen appears.</li> <li>5. Select the <b>Open</b> option from the <b>Filter by</b> list to view all unassigned To Dos.</li> </ol>

If you want to	Then
	6. Click the link in the <b>Message</b> column corresponding to the To Do of the upload request that you want to review.

The **Upload Request** screen appears.

- Review the upload request details.
- Click the **Reject** button in the **Upload Request** zone.

The **Reject Upload Request** window appears. It contains following fields:

Field Name	Field Description	Mandatory (Yes or No)
Status Reason	Used to indicate the reason why you want to reject the upload request.	Yes
Comments	Used to specify additional information while rejecting the upload request.	No

**Note:** The **Reject** button appears only when:

- The upload request is in the **Approval In Progress** status.
- A user with the approval To Do role is reviewing the upload request.

- Select the rejection reason from the **Status Reason** list.
- Click **Save**.

The status of the upload request is changed to **Rejected**.

### Related Topics

For more information on...	See...
How to search for an upload request	<a href="#">Searching for an Upload Request</a> on page 1659
<b>Upload Request</b> screen	<a href="#">Upload Request (Used for Viewing)</a> on page 1664
<b>Upload Request</b> zone	<a href="#">Upload Request</a> on page 1664

## Viewing the Data Record Details

### Procedure

To view the details of a data record:

- Search for the data record in the **Data Records** zone in the **Upload Request** screen.
- In the **Search Results** section, click the **View**  icon in the **View** column corresponding to the data record whose details you want to view.

The **Data Record Details** window appears. It contains the following fields:

Field Name	Field Description
Sr. No.	Displays the sequential number of data.



Field Name	Field Description
CSV Column Header	Displays name of the column in uploaded CSV file.
CSV Column Value	Displays value in the column in uploaded CSV file.

- View the details of the data record in the **Data Record Details** window.

### Related Topics

For more information on...	See...
<b>Data Record</b> zone	<a href="#">Data Records</a> on page 1667

## Viewing the Log of an Upload Request

### Procedure

To view the log of an upload request:

- Search for the upload request in the **Upload Request** screen.
- In the **Search Results** section, click the link in the **Upload Request Information** column corresponding to the upload request whose log you want to view.

The **Upload Request** screen appears. It consists of the following tabs:

- Main** – Displays information about the upload request. It contains the following zones:
    - Upload Request** – Displays the details of the upload request.
    - Data Records** – Lists the data records of the upload request.
  - Log** – Lists the complete trail of actions performed on the upload request. This tab contains the following zone:
    - Upload Request Log** – Displays the trail of actions performed on the particular upload request.
- Click the **Log** tab.

The **Upload Request Log** zone in the **Log** tab contains the following columns:

Column Name	Column Description
Date/Time	Displays the date and time when the action was performed on the upload request.
Details	Displays the details about the action performed on the upload request.
User	Indicates the user who has performed the action on the upload request.
Log Type	Indicates the type of log.
Related Object	Indicates the object or entity which is generated when the action is performed on the upload request.
Status Reason	Indicates the reason why the upload request was rejected.

**Note:** You can manually add a log entry for the upload request by clicking the **Add Log Entry** link in the upper right corner of the **Upload Request Log** zone.

### Related Topics

For more information on...	See...
How to search for an Upload request	<a href="#">Searching for an Upload Request</a> on page 1659
How to add a log entry for an Upload request	<a href="#">Adding a Log Entry for an Upload Request</a> on page 1682

## Adding a Log Entry for an Upload Request

### Procedure

To add a log entry for an upload request:

1. Search for the upload request in the **Upload Request** screen.
2. In the **Search Results** section, click the link in the **Upload Request Information** column corresponding to the upload request whose log you want to edit.

The **Upload Request** screen appears. It consists of the following tabs:

- **Main** – Displays information about the upload request. It contains the following zones:
  - **Upload Request** – Displays the details of the upload request.
  - **Data Records** – Lists the data records of the upload request.
- **Log** – Lists the complete trail of actions performed on the upload request. This tab contains the following zone:
  - **Upload Request Log** – Displays the trail of actions performed on the particular upload request.

3. Click the **Log** tab.

The **Log** tab appears.

4. Click the **Add Log Entry** link in the upper right corner of the **Upload Request Log** zone.

The **Add Upload Request Log** window appears. It contains the following fields:

Field Name	Field Description	Mandatory (Yes or No)
Upload Request Information	Displays information about the upload request.	Not applicable
Log Details	Used to specify additional comments on the upload request.	Yes

5. Enter the comments in the **Log Details** field.
6. Click **Save**.

The log entry is added in the **Upload Request Log** zone.

### Related Topics

For more information on...	See...
How to search for an upload request	<a href="#">Searching for an Upload Request</a> on page 1659

---

# Chapter 25

---

## General Ledger (GL) Accounting Template

---

### Topics:

- [GL Accounting Template \(Without Approval\) Status Transition](#)
- [GL Accounting Template \(With Approval\) Status Transition](#)
- [Algorithms Used in C1- GLAT](#)
- [Prerequisites](#)
- [GL Accounting Template \(Used for Searching\)](#)
- [GL Accounting Template \(Used for Viewing\)](#)

Oracle Revenue Management and Billing until now created FT GL entries while generating the financial transactions for adjustments, payments, and bill segments. The FT GL entries were created using the distribution codes from the adjustment type, rate component, billable charge pass through line, or contract type depending on the type of financial transaction. Now, the system enables you to override the distribution code used for creating FT GL entries using the GL Accounting Template feature.

The system allows you to define a GL Accounting template for each process and sub processes combination for a date range. Based on the parameters defined in the **FT Generation** algorithms, the system either uses the standard process or GL Accounting Template for FT GL creation. The GL Accounting template for the specified process and sub processes combination which is effective on the accounting date is used for FT GL creation.

There should be at least one debit and credit lines in the GL Accounting template. You can define maximum 10 lines in the GL Accounting template. Each line should contain the following information:

- Whether the line should be used to create a debit FT GL entry or credit FT GL entry
- Conditional algorithm (created using the **C1-GLATLC** algorithm type) to indicate whether the line should be used to create the FT GL entry or not
- Distribution code to indicate the GL Account against which the FT GL entry should be created
- User defined amount, such as Amount 01, Amount 02, or Amount 03

The line with the Amount 01 user defined amount is used to create balancing FT GL entry against the contract type. The line with the Amount 02, Amount 03, ..., and Amount 10 user defined amount is used to create FT GL entries for bill segment calculation lines, non-calculated adjustments, adjustment calculation lines, or payments. In case of bill segments and calculated adjustments, the lines with the Amount 02, Amount 03, ..., Amount 10 user defined amount are mapped to calculation line amounts based on the rate component sequence.

You can optionally configure the system to use the approval workflow process while activating or deactivating the GL Accounting templates. If you want to enable the approval workflow process, you need to define algorithms using the following algorithm types:

- C1-GLATAPPEN
- C1-GLATSUB

If the **Approval Required (Y or N)** parameter in an algorithm created using the **C1-GLATSUB** algorithm type is set to **Y**, then on submitting or deactivating the GL Accounting template, the approval workflow process creates a To Do

for the approver to review the GL Accounting template. Once the approver approves a GL Accounting template, the status of the GL Accounting template is set to **Active** or **Inactive**.

We are supporting the following process and sub processes combinations while creating the GL Accounting template:

Process	BS	AD	PS
Sub Process 1	Contract Type	Adjustment Type	Bank Account
Sub Process 2	Division	Contract Type	Contract Type
Sub Process 3	Rate Schedule	Division	Division
Sub Process 4	-	-	-
Sub Process 5	-	-	-

For example, you can define the following the GL Accounting templates using the above supported process and sub processes combinations:

GL Accounting Template	Process	Sub Process 1	Sub Process 2	Sub Process 3
GLAT1	BS	CT1	D1	RS1
GLAT2	BS	CT2	D1	RS1
GLAT3	BS	CT3	D2	RS2
GLAT4	PS	BA1	CT1	D1
GLAT5	PS	BA2	CT2	D2
GLAT6	AD	AT1	CT1	D1
GLAT7	AD	AT1	CT2	D2

While creating the GL Accounting template for BS and AD processes, you need to ensure that the line with the Amount 1 user defined amount is a debit line. However, while creating the GL Accounting template for PS process, you need to ensure that the line with the Amount 1 user defined amount is a credit line.

Based on the customer requirements, you can define GL Accounting template for various custom process and sub processes combinations.

The **Create Additional FT GL Entries** parameter is added in the **Assign GL Account to Financial Transaction (C1-GLASN)** and **Assign GL Account to Financial Transaction (GLASSGN2)** batches. If you set this parameter to **Y**, the **C1-GLCE** algorithm is invoked. Based on the parameters defined in the algorithm, the system checks whether there is a GL Accounting template which is effective on the accounting date for the specified process and sub processes combination. If the effective GL Accounting template is available, the system creates additional FT GL entries for the financial transactions. If the financial transaction's currency is different from the division's base currency, the algorithm will create FT GL extension for the respective financial transaction.

Two new parameters are added in the **ADJT-NM**, **ADJT-AC**, **ADJT-TA**, **ADJT-TC**, **ADJT-AD**, **ADJT-GL**, **PSEG-NM**, **PSEG-AC**, **PSEG-CA**, **BSBF-BA**, **BSBF-LO** algorithm types:

- **Use GL Accounting Template (Y or N)** - Indicates whether the FT GL entries should be created using the lines in the GL Accounting template. The valid values are **Y** and **N**.
- **Show the GL Accounting Template Error When Header Record Not Found (Y or N)** - Indicates whether you want to show error message when the effective GL Accounting template is not available for the process and sub processes combination. If you set the value of this parameter to **N**, the algorithm uses the standard process for FT GL creation when the effective GL Accounting template is not available.

The following table explains how the algorithms created using the following algorithm types create FT GL entries:

Algorithm Type	Use GL Accounting Template (Y or N)	Calculated Adjustment Distribution Code Source (AT - Adjustment Type, CL - Calc Lines)	Algorithm Behaviour
ADJT-NM, ADJT-AC, ADJT-TA, ADJT-TC, ADJT-AD, and ADJT-GL	N	CL	Creates FT GL for the adjustment calculation line using the distribution code on the respective rate component and the balancing FT GL using the distribution code on contract type.
ADJT-NM, ADJT-AC, ADJT-TA, ADJT-TC, ADJT-AD, and ADJT-GL	Y	CL	Creates debit and credit FT GL entries using the lines in the GL Accounting template.
ADJT-NM, ADJT-AC, ADJT-TA, ADJT-TC, ADJT-AD, and ADJT-GL	N	AT	Creates FT GL for the adjustment using the distribution code on the respective adjustment type and the balancing FT GL using the distribution code on contract type.
ADJT-NM, ADJT-AC, ADJT-TA, ADJT-TC, ADJT-AD, and ADJT-GL	Y	AT	Creates debit and credit FT GL entries using the lines in the GL Accounting template.

If the **Use GL Accounting Template (Y or N)** parameter is set to **N** in the algorithms created using the **PSEG-NM**, **PSEG-AC**, and **PSEG-CA** algorithm types, the system creates FT GL for the payment segment using the distribution code on the respective payment segment type and the balancing FT GL using the distribution code on contract type. However, if the **Use GL Accounting Template (Y or N)** parameter is set to **Y**, the system creates debit and credit FT GL entries using the lines in the GL Accounting template.

If the **Use GL Accounting Template (Y or N)** parameter is set to **N** in the algorithms created using the **BSBF-BA** and **BSBF-LO** algorithm types, the system behaves in the following manner:

<b>If the bill segment is...</b>	<b>Then, the system...</b>
Created from a billable charge with SQI and/or price item details	Creates FT GL for the bill segment calculation line using the distribution code on the respective rate component and the balancing FT GL using the distribution code on contract type.
Created from a pass through billable charge	Creates FT GL for the pass through line using the distribution code on the respective pass through line and the balancing FT GL using the distribution code on contract type.
Created from a billable charge with pass through charges, SQI, and price item details	Creates... <ul style="list-style-type: none"> <li>• FT GL for the bill segment calculation line using the distribution code on the respective rate component</li> <li>• FT GL for the pass through line using the distribution code on the respective pass through line</li> <li>• Balancing FT GL using the distribution code on contract type</li> </ul>
A post processing bill segment	Creates FT GL for the post processing FT using the distribution code on the respective rate component and the balancing FT GL using the distribution code on contract type.

However, if the **Use GL Accounting Template (Y or N)** parameter is set to **Y** in the algorithms created using the **BSBF-BA** and **BSBF-LO** algorithm types, the system behaves in the following manner:

<b>If the bill segment is...</b>	<b>Then, the system...</b>
Created from a billable charge with SQI and/or price item details	Creates debit and credit FT GL entries using the lines in the GL Accounting template.
Created from a pass through billable charge	Does not use the GL Accounting template. It creates FT GL for the pass through line using the distribution code on the respective pass through line and the balancing FT GL using the distribution code on contract type.

If the bill segment is...	Then, the system...
Created from a billable charge with pass through charges, SQI, and price item details	Creates... <ul style="list-style-type: none"> <li>• FT GL for bill segment calculation line using the lines in the GL Accounting template.</li> <li>• FT GL for the pass through line using the distribution code on the respective pass through line.</li> <li>• Balancing FT GL using the line in the GL Accounting template.</li> </ul>
A post processing bill segment	Creates debit and credit FT GL entries using the lines in the GL Accounting template.

## GL Accounting Template (Without Approval) Status Transition

---

The following figure graphically indicates how a GL Accounting Template moves from one status to another when approval workflow is off:

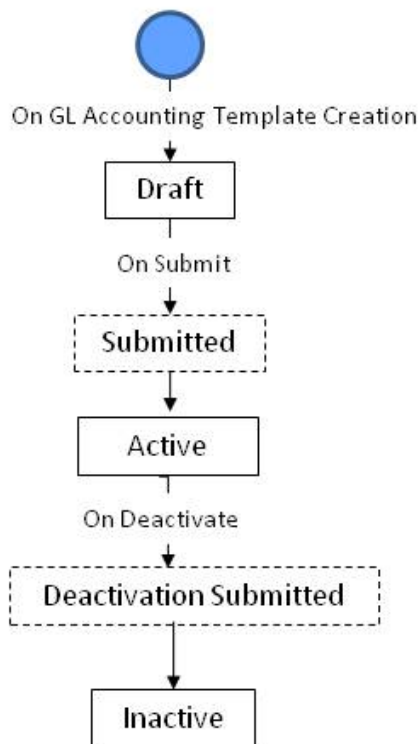

## GL Accounting Template (With Approval) Status Transition

---

The following figure graphically indicates how a GL Accounting Template moves from one status to another when approval workflow is on:



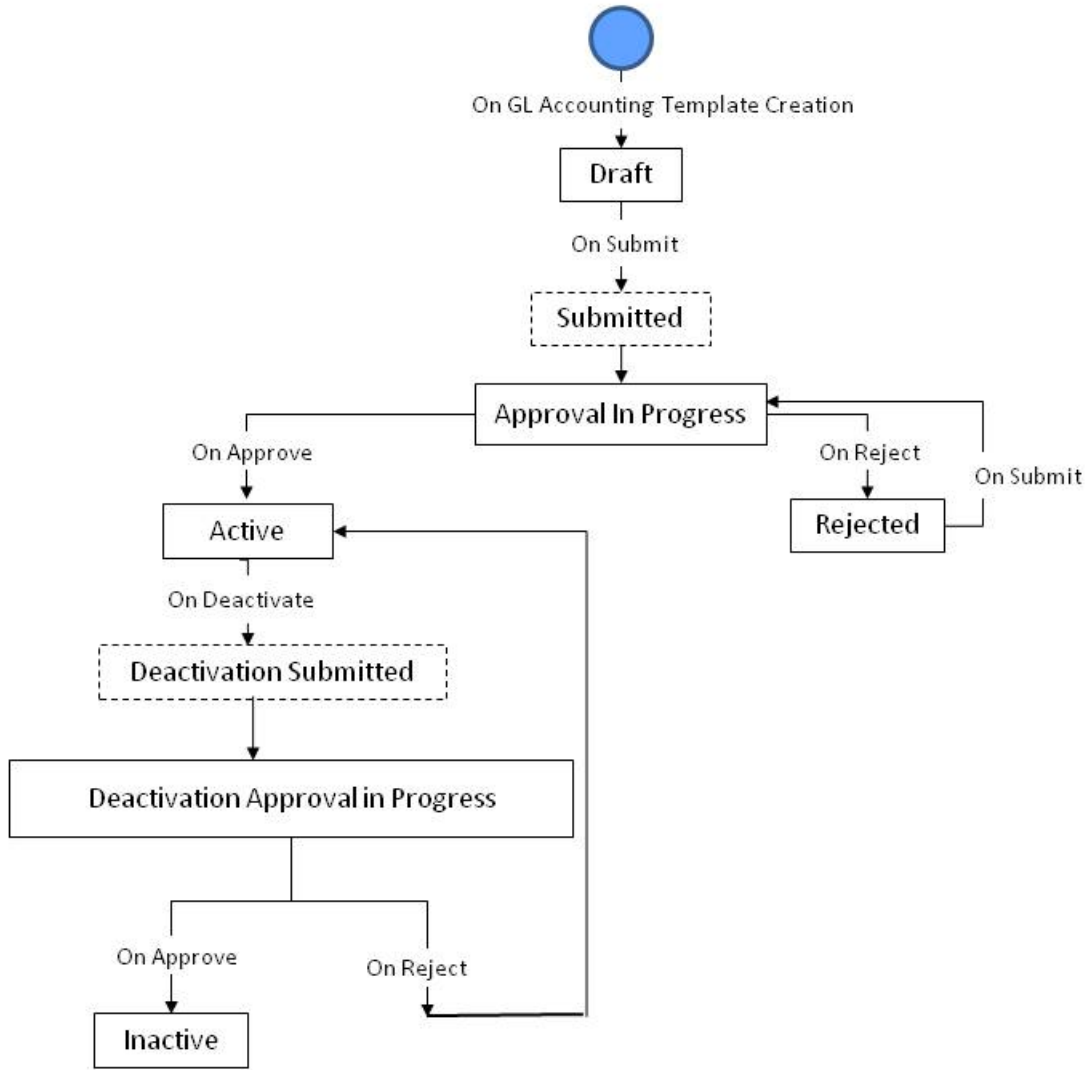

## Algorithms Used in C1- GLAT

The following table lists the algorithms which are attached to the **C1-GLAT** business object:

System Event	Algorithm	Algorithm Type	Description
Information	C1-GLAT-INF	C1-GLAT-INF	This algorithm generates the GLAT information string which appears throughout the application. This algorithm concatenates the following fields: <ul style="list-style-type: none"> <li>GLAT Description</li> <li>GLAT Status Description</li> <li>GLAT ID</li> </ul>

The following table lists the algorithms which are used in the lifecycle of the **C1-GLAT** business object:

Status	System Event	Algorithm	Algorithm Type	Description
Draft	Exit	F1-TODOCOMPL	F1-TODOCOMPL	This algorithm type completes To Do entries that are linked to an object when the object exits a given state. The system finds all open To Do entries with drill keys for the current business object's primary key, and completes them, unless the To Do entry's type has been configured with an Exclude To Do Type Characteristic Type indicating that it should not be automatically completed.
Submitted	Enter	C1-GLATSUB	C1-GLATSUB	This algorithm checks the following: <ul style="list-style-type: none"> <li>If soft parameter value is set to Y then approval workflow will be triggered.</li> </ul>
Approval in Progress	Enter	C1-GLATAPPEN	C1-GLATAPPEN	This algorithm creates the To Do based on the Approval To Do Type configured in algorithm.
Approval in Progress	Exit	C1-GLATAPPEX	C1-GLATAPPEX	This algorithm checks whether an approver is associated with the approval To Do Role specified in the <b>C1-GLATAAPEN</b> Algorithm. It does not allow the submitter to approve or reject the GLAT request.
Approval in Progress	Exit	F1-TODOCOMPL	F1-TODOCOMPL	This algorithm type completes To Do entries that are linked to an object when the object exits a given state. The system finds all open To Do entries with drill keys for the current business object's primary key, and completes them, unless the To Do entry's type has been configured with an Exclude To Do Type Characteristic Type indicating that it should not be automatically completed.
Active	-	-	-	-
Deactivation Submitted	Enter	C1-GLATSUB	C1-GLATSUB	This algorithm checks the following: <ul style="list-style-type: none"> <li>If soft parameter value is set to Y then approval workflow will be triggered.</li> </ul>
Deactivation Approval In Progress	Enter	C1-GLATAPPEN	C1-GLATAPPEN	This algorithm creates the To Do based on the Approval To Do Type configured in algorithm.

Status	System Event	Algorithm	Algorithm Type	Description
Deactivation Approval In Progress	Exit	C1-GLATAPPEX	C1-GLATAPPEX	This algorithm checks whether an approver is associated with the approval To Do Role specified in the <b>C1-GLATAAPEN</b> Algorithm. It does not allow the submitter to approve or reject the GLAT request.
Deactivation Approval In Progress	Exit	F1-TODOCOMPL	F1-TODOCOMPL	This algorithm type completes To Do entries that are linked to an object when the object exits a given state. The system finds all open To Do entries with drill keys for the current business object's primary key, and completes them, unless the To Do entry's type has been configured with an Exclude To Do Type Characteristic Type indicating that it should not be automatically completed.
Rejected	Exit	F1-TODOCOMPL	F1-TODOCOMPL	This algorithm type completes To Do entries that are linked to an object when the object exits a given state. The system finds all open To Do entries with drill keys for the current business object's primary key, and completes them, unless the To Do entry's type has been configured with an Exclude To Do Type Characteristic Type indicating that it should not be automatically completed.
Inactive	-	-	-	-

## Prerequisites

To setup the GL Accounting Template, you need to do the following:

- Define rejected status reasons for the **C1-GLAT** business object
- Define deactivated status reasons for the **C1-GLAT** business object
- Assign the **C1-GLAT** To Do type to a To Do role whose users must receive To Do generated while submitting a template for approval
- Define the required algorithms, for approval and To Do type role and configurations

## GL Accounting Template (Used for Searching)

The **GL Accounting Template** screen allows you to search for a template using various search criteria. It also allows you to create template. Through this screen, you can navigate to the following screen:

- [GL Accounting Template \(Used for Viewing\)](#) on page 1697

This screen consists of the following zones:

- [Search GL Accounting Template](#) on page 1692
- [GL Accounting Template Lines](#) on page 1693

## Search GL Accounting Template

The **Search GL Accounting Template** zone allows you to search for GL accounting templates using various search criteria. This zone contains the following two sections:

- **Search Criteria** — The **Search Criteria** section contains the following fields:

Field Name	Field Description	Mandatory (Yes or No)
Template ID	Used to search a particular template.	No
Description	Used to specify the description of a template.	No
Status	Used to indicate the status of the template. The valid values are: <ul style="list-style-type: none"> <li>• Draft</li> <li>• Approval In Progress</li> <li>• Deactivation Approval In Progress</li> <li>• Active</li> <li>• Inactive</li> <li>• Rejected</li> </ul>	No
Process	Used to search a particular process.	No
Sub Process 1	Used to search a particular Sub Process 1.	No
Sub Process 2	Used to search a particular Sub Process 2.	No
Sub Process 3	Used to search a particular Sub Process 3.	No
Sub Process 4	Used to search a particular Sub Process 4.	No
Sub Process 5	Used to search a particular Sub Process 5.	No
Effective Start Date	Used to search templates which are effective from a particular date.	No
Effective End Date	Used to search templates which are effective till a particular date.	No

**Note:** You must specify at least one search criterion while searching for a template.

- **Search Results** — On clicking the **Search** button, the search results appear based on the specified search criteria. The **Search Results** section contains the following columns:

Column Name	Column Description
Process	Displays the process.
GL Accounting Template Request Information	Displays information about the template. <div style="border: 1px solid black; padding: 5px; margin-top: 5px;"> <p><b>Note:</b> It has a link. On clicking the link, the <b>GL Accounting Template</b> screen appears where you can view the details of the respective template.</p> </div>
Description	Displays the description of process.

Column Name	Column Description
Sub Process 1	Displays the Sub Process 1.
Sub Process 2	Displays the Sub Process 2.
Sub Process 3	Displays the Sub Process 3.
Sub Process 4	Displays the Sub Process 4.
Sub Process 5	Displays the Sub Process 5.
Effective Start Date	Displays the date from when the template is effective.
Effective End Date	Displays the date till when the template is effective.
Status	Displays the status of template.

### Related Topics

For more information on...	See...
How to search for a GL Accounting Template	<a href="#">Searching for a GL Accounting Template</a> on page 1694
How to view the details of a GL Accounting Template	<a href="#">Viewing the GL Accounting Template Details</a> on page 1696
How to create a GL Accounting Template	<a href="#">Creating a GL Accounting Template</a> on page 1694
GL Accounting Template Lines zone	<a href="#">GL Accounting Template Lines</a> on page 1693

## GL Accounting Template Lines

The **GL Accounting Template Lines** zone displays the details of the template lines. This zone contains the following columns:

Column Name	Column Description
Credit/Debit	Displays whether the template lines are of credit or debit.
Conditional Algorithm	Displays the algorithm that specified that template line is valid or not.
Distribution Code	Displays the distribution code which indicates the template associated with the charge.
User Defined Amount Field	Displays the amount to be used in a template line.

**Note:** By default, the **GL Accounting Template Lines** zone does not appear in the **GL Accounting Template** screen. It appears only when you click the **Broadcast**  icon corresponding to the template in the **Search Results** section.

### Related Topics

For more information on...	See...
How to search for a GL Accounting Template	<a href="#">Searching for a GL Accounting Template</a> on page 1694
How to view the details of a GL Accounting Template	<a href="#">Viewing the GL Accounting Template Details</a> on page 1696
How to create a GL Accounting Template	<a href="#">Creating a GL Accounting Template</a> on page 1694
Search GL Accounting Template zone	<a href="#">Search GL Accounting Template</a> on page 1692

## Searching for a GL Accounting Template

### Procedure

To search for a GL Accounting template:

1. Click the **Admin** link in the **Application** toolbar.  
A list appears.
2. From the **Admin** menu, select **G** and then click **GL Accounting Template**.  
The **GL Accounting Template** screen appears.
3. Enter the search criteria in the **Search GL Accounting Template** zone.

**Note:** ORMB search engine supports wildcard search, where you can substitute the percentage (%) symbol as a stand in for any word or letter in a search criteria. You can use the ‘%’ wildcard character in all input fields except the date and ID fields. The ‘%’ wildcard character is suffixed automatically at the end of the partial search criteria. Therefore, you may or may not specify the wildcard character at the end of the partial search criteria. However, you have to prefix the wildcard character manually wherever required.

4. Click **Search**.

A list of templates that meet the search criteria appears in the **Search Results** section.

### Related Topics

For more information on...	See...
GL Accounting Template screen	<a href="#">GL Accounting Template (Used for Searching)</a> on page 1691
Search GL Accounting Template zone	<a href="#">Search GL Accounting Template</a> on page 1692

## Creating a GL Accounting Template

### Prerequisites

To create a GL Accounting template, you should have:

- Conditional Algorithms and Distribution codes defined in the application.

### Procedure

To create a GL Accounting template:

1. Click the **Admin** link in the **Application** toolbar.  
A list appears.
2. From the **Admin** menu, select **G** and then click **GL Accounting Template**.  
The **GL Accounting Template** screen appears.
3. Click the **Add** button in the **Page Title** area of the **GL Accounting Template** screen.

The **GL Accounting Template** screen appears. It contains the following sections:

- **Main** — Used to specify basic details about the template. This section contains the following fields:

Field Name	Field Description	Mandatory (Yes or No)
Process	Used to specify a particular process.	Yes
Description	Used to indicate the description of a process.	Yes
Sub Process 1	Used to specify a Sub Process 1.	Yes (Conditional) <b>Note:</b> This field is required if <b>Process</b> is <b>Bill Segment or Payment Segment or Adjustments</b>
Sub Process 2	Used to specify a Sub Process 2.	Yes (Conditional) <b>Note:</b> This field is required if <b>Process</b> is <b>Bill Segment or Payment Segment or Adjustments</b>
Sub Process 3	Used to specify a Sub Process 3.	Yes (Conditional) <b>Note:</b> This field is required if <b>Process</b> is <b>Bill Segment or Payment Segment or Adjustments.</b>
Sub Process 4	Used to specify a Sub Process 4.	No
Sub Process 5	Used to specify a Sub Process 5.	No
Effective Start Date	Used to specify date for a template which is effective from a particular date.	Yes
Effective End Date	Used to specify date for a template which is effective till a particular date.	No

- **GL Accounting Template Lines** —Used to specify the template lines in a GL accounting template. This section contains the following columns:

Column Name	Column Description	Mandatory (Yes or No)
Sequence No	Used to specify the sequence number.	Yes
Credit/Debit	Used to indicate whether template lines are of credit or debit.	Yes
Conditional Algorithm	Used to specify the algorithm which specifies that template line is valid or not.	No
Distribution Code	Used to indicate the distribution code which indicates the template associated with the charge.	Yes
User Defined Amount Field	Used to indicate the amount to be used in a template line.	Yes

#### 4. Enter the required details

**Note:**

You can search for a conditional algorithm and distribution code by clicking the **search**  icon corresponding to the respective field.

At least one credit and one debit line is required while defining a template.

System will not allow to add a template having same set of process, sub processes and effective date. If there is a template already created and its status is Inactive, then only template can be created with same set of process, sub processes and effective date.

Each conditional line must have unique User Defined Amount Field value.

5. Add template lines for a template defined.

6. Click **Save**.

The GL Accounting template is created and the status of the template is set to **Draft**. The **GL Accounting Template** screen appears with the details of template.

**Related Topics**

For more information on...	See...
GL Accounting Template screen	<a href="#">GL Accounting Template (Used for Searching)</a> on page 1691
How to edit a GL Accounting Template	<a href="#">Editing a GL Accounting Template</a> on page 1700

**Viewing the GL Accounting Template Details****Procedure**

To view the details of a GL Accounting Template:

1. Search for the template in the **GL Accounting Template** screen.
2. In the **Search Results** section, click the link in the **GL Accounting Template Information** column corresponding to the template whose details you want to view.

The **GL Accounting Template** screen appears. It consists of the following tabs:

- **Main** – Displays information about the template. It contains the following zone:
  - **GL Accounting Template** – Displays the details of the template.
- **Log** – Lists the complete trail of actions performed on the template. This tab contains the following zone:
  - **GL Accounting Template Log** – Displays the trail of actions performed on the particular template.

3. View the details of the template in the **GL Accounting Template** zone.

**Related Topics**

For more information on...	See...
GL Accounting Template screen	<a href="#">GL Accounting Template (Used for Searching)</a> on page 1691
GL Accounting Template zone	<a href="#">GL Accounting Template</a> on page 1697
How to search for a GL Accounting Template	<a href="#">Searching for a GL Accounting Template</a> on page 1694
How to view a GL Accounting Template Lines	<a href="#">Viewing the GL Accounting Template Lines Details</a> on page 1697



## Viewing the GL Accounting Template Lines Details

### **Procedure**

To view the details of a GL Accounting Template Lines:

1. Search for the template in the **GL Accounting Template** screen.
2. In the **Search Results** section, click the **Broadcast**  icon corresponding to the template in the **Search Results** section.

The **GL Accounting Template Lines** zone appears in the **GL Accounting Template** screen.

3. View the details of the template lines in the **GL Accounting Template Lines** zone.

### **Related Topics**

For more information on...	See...
<b>GL Accounting Template</b> screen	<a href="#">GL Accounting Template (Used for Searching)</a> on page 1691
<b>GL Accounting Template</b> zone	<a href="#">GL Accounting Template</a> on page 1697
<b>GL Accounting Template Lines</b> zone	<a href="#">GL Accounting Template Lines</a> on page 1693

## GL Accounting Template (Used for Viewing)

Once you create a template, the **GL Accounting Template** screen allows you to:

- View the details of a template
- Edit the details of a template
- Delete a template
- Submit a template for approval
- Approve or reject a template
- Deactivate a template

This screen consists of the following tabs:

- **Main** – Displays information about the template. It contains the following zone:
  - **GL Accounting Template** – Displays the details of the template.
- **Log** — Lists the complete trail of actions performed on the template. This tab contains the following zone:
  - **GL Accounting Template Log** – Displays the trail of actions performed on the particular template.

### **GL Accounting Template - Main**

The **Main** tab on the **GL Accounting Template** contains the following zone:

[GL Accounting Template](#) on page 1697

#### **GL Accounting Template**

The **GL Accounting Template** zone displays the details of the template. This zone contains the following sections:

- **Main** — This section provides basic information about the GL Accounting template. It contains the following fields:

Field Name	Field Description
GL Accounting Template Information	Displays information about the template
Status	Indicates the status of the template.
Process	Displays the process.
Description	Displays the description of the process.
Sub Process 1	Displays the Sub Process 1.
Sub Process 2	Displays the Sub Process 2.
Sub Process 3	Displays the Sub Process 3.
Sub Process 4	Displays the Sub Process 4.
Sub Process 5	Displays the Sub Process 5.
Effective Start Date	Displays the date from when the template is effective.
Effective End Date	Displays the date till when the template is effective.

- **GL Accounting Template Lines** — Lists the GL Accounting template lines. It contains the following columns:

Column Name	Column Description
Sequence No	Displays the sequence number.
Credit/Debit	Displays whether the template lines are of credit or debit.
Conditional Algorithm	Displays the algorithm that specified that template line is valid or not.
Distribution Code	Displays the distribution code which indicates the template associated with the charge.
User Defined Amount Field	Displays the amount to be used in a template line.

- **Record Actions** — This section contains the following buttons:

Button Name	Button Description
Edit	Used to edit the details of the template. <b>Note:</b> The <b>Edit</b> button appears only when the template is in the <b>Draft</b> or <b>Rejected</b> status.
Delete	Used to delete the template. <b>Note:</b> The <b>Delete</b> button appears only when the template is in the <b>Draft</b> or <b>Rejected</b> status.
Submit	Used to activate the template. <b>Note:</b> The <b>Submit</b> button appears only when the template is in the <b>Draft</b> or <b>Rejected</b> status.

Button Name	Button Description
Approve	Used to approve the template. <b>Note:</b> the <b>Approve</b> button appears only when the template is in the <b>Approval In Progress</b> or <b>Deactivation Approval In Progress</b> status.
Reject	Used to reject the template. <b>Note:</b> the <b>Reject</b> button appears only when the template is in the <b>Approval In Progress</b> or <b>Deactivation Approval In Progress</b> status.
Deactivate	Used to deactivate the active template. <b>Note:</b> The <b>Deactivate</b> button appears only when the template is in the <b>Active</b> status.

- **Record Information** — This section contains the following fields:

Field Name	Field Description
Business Object	Indicates the business object using which the template is created. In addition, a context menu appears corresponding to this field which helps in navigating to other screens in the application. <b>Note:</b> It has a link. On clicking the link, the <b>Business Object</b> screen appears where you can view the details of the respective business object.

## GL Accounting Template - Log

The **Log** tab on the **GL Accounting Template** screen contains the following zone:

[GL Accounting Template Log](#) on page 1699

### GL Accounting Template Log

The **GL Accounting Template Log** zone on the **GL Accounting Template** screen lists the complete trail of actions performed on the GL Accounting template. This zone contains the following columns:

Column Name	Column Description
Date/Time	Displays the date and time when the action was performed on the template.
Details	Displays the details about the action performed on the template.
User	Indicates the user who has performed the action on the template.
Log Type	Indicates the type of log.
Related Object	Indicates the object or entity which is generated when the action is performed on the template.
Status Reason	Displays the status reason of action performed on the template.

**Note:** You can manually add a log entry for the template by clicking the **Add Log Entry** link in the upper right corner of the **GL Accounting Template Log** zone.

The **Add GL Accounting Template Log** window appears. Enter **Log Details** and click **Save**. The GL Accounting Template log is added.

**Related Topics**

For more information on...	See...
How to view the log of a GL Accounting Template	<a href="#">Viewing the Log of a GL Accounting Template</a> on page 1707

**Editing a GL Accounting Template****Procedure**

To edit a GL Accounting Template:

1. Search for the template in the **GL Accounting Template** screen.
2. In the **Search Results** section, click the link in the **GL Accounting Template Information** column corresponding to the template whose details you want to edit.

The **GL Accounting Template** screen for editing appears.

3. Click the **Edit** button in the **GL Accounting Template** zone.

**Note:** The **Edit** button appears only when the template is in the **Draft** or **Rejected** status.

The **GL Accounting Template** screen appears. It contains the following sections:

- **Main** — Used to specify basic details about the template. This section contains the following fields:

Field Name	Field Description	Mandatory (Yes or No)
Process	Used to specify a particular process.	Yes
Description	Used to indicate the description of a process.	Yes
Sub Process 1	Used to specify a Sub Process 1.	Yes (Conditional) <b>Note:</b> This field is required if <b>Process</b> is <b>Bill Segment</b> or <b>Payment Segment</b> or <b>Adjustments</b>
Sub Process 2	Used to specify a Sub Process 2.	Yes (Conditional) <b>Note:</b> This field is required if <b>Process</b> is <b>Bill Segment</b> or <b>Payment Segment</b> or <b>Adjustments</b>
Sub Process 3	Used to specify a Sub Process 3.	Yes (Conditional) <b>Note:</b> This field is required if <b>Process</b> is <b>Bill Segment</b> or <b>Payment Segment</b> or <b>Adjustments</b> .
Sub Process 4	Used to specify a Sub Process 4.	No
Sub Process 5	Used to specify a Sub Process 5.	No
Effective Start Date	Used to specify date for a template which is effective from a particular date.	Yes

Field Name	Field Description	Mandatory (Yes or No)
Effective End Date	Used to specify date for a template which is effective till a particular date.	No

- **GL Accounting Template Lines** — Used to specify the template lines in a GL accounting template. This section contains the following columns:

Column Name	Column Description	Mandatory (Yes or No)
Sequence No	Used to specify the sequence number.	Yes
Credit/Debit	Used to indicate whether template lines are of credit or debit.	Yes
Conditional Algorithm	Used to specify the algorithm which specifies that template line is valid or not.	No
Distribution Code	Used to indicate the distribution code which indicates the template associated with the charge.	Yes
User Defined Amount Field	Used to indicate the amount to be used in a template line.	Yes

**Note:**

If you want to specify more than one template lines, click the **Add** (+) icon corresponding to the sequence No and then specify the details.

However, if you want to remove a template line from the template, click the **Delete** (🗑️) icon corresponding to the sequence No.

You can search for a conditional algorithm and distribution code by clicking the **search** (🔍) icon corresponding to the respective field.

At least one credit and one debit line is required while defining a template.

4. Modify the details of the template, if required.
5. Click **Save**.

The changes made to the GL Accounting template are saved.

### **Related Topics**

For more information on...	See...
How to search for a GL Accounting Template	<a href="#">Searching for a GL Accounting Template</a> on page 1694
<b>GL Accounting Template</b> screen	<a href="#">GL Accounting Template (Used for Searching)</a> on page 1691
<b>GL Accounting Template</b> zone	<a href="#">GL Accounting Template</a> on page 1697

## **Deleting a GL Accounting Template**

### **Procedure**

To delete a GL Accounting Template:

1. Search for the template in the **GL Accounting Template** screen.
2. In the **Search Results** section, click the link in the **GL Accounting Template Information** column corresponding to the template that you want to delete.

The **GL Accounting Template** screen appears.

3. Click the **Delete** button in the **GL Accounting Template** zone.

A message appears confirming whether you want to delete the template.

**Note:** The **Delete** button appears only when the template is in the **Draft** or **Rejected** status.

4. Click **OK**.

The GL Accounting template is deleted.

**Note:**

You can delete a template only when its status is **Draft**.

### **Related Topics**

For more information on...	See...
How to search for a GL Accounting Template	<a href="#">Searching for a GL Accounting Template</a> on page 1694
<b>GL Accounting Template</b> screen	<a href="#">GL Accounting Template (Used for Searching)</a> on page 1691
<b>GL Accounting Template</b> zone	<a href="#">GL Accounting Template</a> on page 1697

## **Submitting a GL Accounting Template**

### **Prerequisites**

To submit a GL Accounting Template, you should have:

- Process and GL Accounting template lines defined in the template.

### **Procedure**

To submit a GL Accounting Template:

1. Search for the template in the **GL Accounting Template** screen.
2. In the **Search Results** section, click the link in the **GL Accounting Template Information** column corresponding to the template that you want to submit.

The **GL Accounting Template** screen appears.

3. Click the **Submit** button in the **GL Accounting Template** zone.

The system behaves in the following manner:

If...	Then...
Approval Required Flag is set to Yes in the <b>C1-GLATSUB</b> algorithm.	A To Do of the <b>C1-GLAT</b> To Do type is created and sent to the approver and the status of the template is changed to <b>Approval In Progress</b> .
Approval Required Flag is set to No in the <b>C1-GLATSUB</b> algorithm.	The template is created using the specified process and the status of the template is changed to <b>Active</b> .

**Note:**

The **Submit** button appears only when the template is in the **Draft** or **Rejected** status.

**Related Topics**

For more information on...	See...
How to search for a GL Accounting Template	<a href="#">Searching for a GL Accounting Template</a> on page 1694
<b>GL Accounting Template</b> screen	<a href="#">GL Accounting Template (Used for Searching)</a> on page 1691
<b>GL Accounting Template</b> zone	<a href="#">GL Accounting Template</a> on page 1697
How to edit a GL Accounting Template	<a href="#">Editing a GL Accounting Template</a> on page 1700
How to delete a GL Accounting Template	<a href="#">Deleting a GL Accounting Template</a> on page 1701

**Approving a GL Accounting Template**

You can view the number of GL Accounting templates which are pending for approval in the **GL Accounting Template** screen. The approver can review, and accordingly approve or reject the template based on the observations.

**Note:** The system will not allow you to approve or reject a template submitted by you.

**Procedure**

To approve a template:

1. Do either of the following:

If you want to...	Then...
Approve a GL Accounting Template through the <b>GL Accounting template</b> screen	<ol style="list-style-type: none"> <li>1. Search for the template in the <b>GL Accounting template</b> screen.</li> <li>2. In the <b>Search Results</b> section, click the link in the <b>GL Accounting Template Information</b> column corresponding to the template which you want to review.</li> </ol>
Approve a GL Accounting Template from the <b>To Do List</b> screen	<ol style="list-style-type: none"> <li>1. Click the <b>Menu</b> link in the <b>Application</b> toolbar. A list appears.</li> <li>2. From the <b>Main</b> menu, select <b>To Do</b> and then click <b>To Do List</b>. The <b>To Do Type for User Search</b> window appears.</li> <li>3. Enter <b>C1-GLAT</b> in the <b>To Do Type</b> field.</li> <li>4. Click the <b>Search</b> button corresponding to the <b>To Do Type</b> field. The <b>To Do List</b> screen appears.</li> </ol>

If you want to...	Then...
	<ol style="list-style-type: none"> <li>5. Select the <b>Open</b> option from the <b>Filter by</b> list to view all unassigned To Dos.</li> <li>6. Click the link in the <b>Message</b> column corresponding to the To Do of the GL Accounting template that you want to review.</li> </ol>

The **GL Accounting Template** screen appears.

2. Review the template details.
3. Click the **Approve** button in the **GL Accounting Template** zone.

The system behaves in the following manner:

If you are...	Then...
Approving a GL Accounting template	The status of the template is changed to <b>Active</b> as specified in the GL Accounting template.

**Note:** The **Approve** button appears only when the template is in the **Approval In Progress** or **Deactivation Approval In Progress** status.

### Related Topics

For more information on...	See...
How to search for a GL Accounting Template	<a href="#">Searching for a GL Accounting Template</a> on page 1694
<b>GL Accounting Template</b> screen	<a href="#">GL Accounting Template (Used for Searching)</a> on page 1691
<b>GL Accounting Template</b> zone	<a href="#">GL Accounting Template</a> on page 1697

## Rejecting a GL Accounting Template

### Prerequisites

To reject a GL Accounting template, you should have:

- Rejection reasons defined in the application

### **Note:**

While rejecting a GL Accounting template, you need to specify the reason why you want to reject the template. You can select the appropriate rejection reason only when you have defined the reasons for the **Rejected** status of the **C1-GLAT** business object in the **Status Reason** screen.

The system will not allow you to approve or reject a template submitted by you.

### Procedure

To reject a GL Accounting template

1. Do either of the following:



If you want to	Then
Reject a GL Accounting template through the <b>GL Accounting Template</b> screen	<ol style="list-style-type: none"> <li>1. Search for the template in the <b>GL Accounting Template</b> screen.</li> <li>2. In the <b>Search Results</b> section, click the link in the <b>GL Accounting Template Information</b> column corresponding to the template which you want to review.</li> </ol>
Reject a GL Accounting template from the <b>To Do List</b> screen	<ol style="list-style-type: none"> <li>1. Click the <b>Menu</b> link in the <b>Application</b> toolbar. A list appears.</li> <li>2. From the <b>Main</b> menu, select <b>To Do</b> and then click <b>To Do List</b>. The <b>To Do Type for User Search</b> window appears.</li> <li>3. Enter <b>C1-GLAT</b> in the <b>To Do Type</b> field.</li> <li>4. Click the <b>Search</b> button corresponding to the <b>To Do Type</b> field. The <b>To Do List</b> screen appears.</li> <li>5. Select the <b>Open</b> option from the <b>Filter by</b> list to view all unassigned To Dos.</li> <li>6. Click the link in the <b>Message</b> column corresponding to the To Do of the template that you want to review.</li> </ol>

The **GL Accounting Template** screen appears.

2. Review the template details.
3. Click the **Reject** button in the **GL Accounting Template** zone.

The **Reject GLAT Request** window appears. It contains following fields:

Field Name	Field Description	Mandatory (Yes or No)
Status Reason	Used to indicate the reason why you want to reject the template	Yes
Comments	Used to specify additional information while rejecting the template.	No

**Note:** The **Reject** button appears only when:

- The template is in the **Approval In Progress** or **Deactivation Approval In Progress** status.
- A user with the approval To Do role is reviewing the template.

4. Select the rejection reason from the **Status Reason** list.
5. Click **Save**.

The status of the template is changed to **Rejected**.

### Related Topics

For more information on...	See...
How to search for a GL Accounting Template	<a href="#">Searching for a GL Accounting Template</a> on page 1694
<b>GL Accounting Template</b> screen	<a href="#">GL Accounting Template (Used for Searching)</a> on page 1691
<b>GL Accounting Template</b> zone	<a href="#">GL Accounting Template</a> on page 1697
How to approve a GL Accounting Template	<a href="#">Approving a GL Accounting Template</a> on page 1703

## Deactivating a GL Accounting Template

### Prerequisites

To deactivate a GL Accounting template, you should have:

- Deactivation reasons defined in the application.

### **Note:**

While deactivating a GL Accounting template, you need to specify the reason why you want to deactivate the template. You can select the appropriate deactivation reason only when you have defined the reasons for the deactivation status of the **C1-GLAT** business object in the **Status Reason** screen.

### Procedure

To deactivate a GL Accounting template:

1. Search for the template in the **GL Accounting Template** screen.
2. In the **Search Results** section, click the link in the **GL Accounting Template Information** column corresponding to the template that you want to deactivate.

The **GL Accounting Template** screen appears.

3. Click the **Deactivate** button in the **GL Accounting Template** zone.

**Note:** The **Deactivate** button appears only when the template is in the **Active** status.

The **Deactivate GLAT Request** window appears. It contains the following fields:

Field Name	Field Description	Mandatory (Yes or No)
Status Reason	Used to indicate the reason for deactivating a template	Yes
Comments	Used to specify the additional comments on the deactivation of template.	No

4. Click **OK**.

The GL Accounting template status is changed to **Deactivation Approval In Progress**.

### Related Topics

For more information on...	See...
How to search for a GL Accounting Template	<a href="#">Searching for a GL Accounting Template</a> on page 1694
<b>GL Accounting Template</b> screen	<a href="#">GL Accounting Template (Used for Searching)</a> on page 1691
<b>GL Accounting Template</b> zone	<a href="#">GL Accounting Template</a> on page 1697

## Viewing the Log of a GL Accounting Template

### Procedure

To view the log of a GL Accounting template:

1. Search for the template in the **GL Accounting template** screen.
2. In the **Search Results** section, click the link in the **GL Accounting Template Information** column corresponding to the template whose log you want to view.

The **GL Accounting Template** screen appears. It consists of the following tabs:

- **Main** – Displays information about the template. It contains the following zone:
  - **GL Accounting Template** – Displays the details of the template.
  - **Log** – Lists the complete trail of actions performed on the template. This tab contains the following zone:
    - **GL Accounting Template Log** – Displays the trail of actions performed on the particular template.

3. Click the **Log** tab.

The **GL Accounting Template Log** zone in the **Log** tab contains the following columns:

Column Name	Column Description
Date/Time	Displays the date and time when the action was performed on the template.
Details	Displays the details about the action performed on the template.
User	Indicates the user who has performed the action on the template.
Log Type	Indicates the type of log.
Related Object	Indicates the object or entity which is generated when the action is performed on the template.
Status Reason	Indicates the reason why the template was rejected or voided.

**Note:** You can manually add a log entry for the template by clicking the **Add Log Entry** link in the upper right corner of the **GL Accounting Template Log** zone.

### Related Topics

For more information on...	See...
How to search for a GL Accounting Template	<a href="#">Searching for a GL Accounting Template</a> on page 1694
How to add a log entry for a GL Accounting Template	<a href="#">Adding a Log Entry for a GL Accounting Template</a> on page 1708

## Adding a Log Entry for a GL Accounting Template

### Procedure

To add a log entry for a GL Accounting Template:

1. Search for the template in the **GL Accounting Template** screen.
2. In the **Search Results** section, click the link in the **GL Accounting Template Information** column corresponding to the template whose log you want to edit.

The **GL Accounting Template** screen appears. It consists of the following tabs:

- **Main** – Displays information about the template. It contains the following zone:
  - **GL Accounting Template** – Displays the details of the template.
- **Log** – Lists the complete trail of actions performed on the template. This tab contains the following zone:
  - **GL Accounting Template Log** – Displays the trail of actions performed on the particular template.

3. Click the **Log** tab.

The **Log** tab appears.

4. Click the **Add Log Entry** link in the upper right corner of the **GL Accounting Template Log** zone.

The **Add GL Accounting Template Log** window appears. It contains the following fields:

Field Name	Field Description	Mandatory (Yes or No)
GL Accounting Template Information	Displays information about the template.	Not applicable
Log Details	Used to specify additional comments on the template.	Yes

5. Enter the comments in the **Log Details** field.
6. Click **Save**.

The log entry is added in the **GL Accounting Template Log** zone.

### Related Topics

For more information on...	See...
How to search for a GL Accounting Template	<a href="#">Searching for a GL Accounting Template</a> on page 1694

---

# Chapter 26

---

## Payment Agreement Request

---

### Topics:

- [Payment Agreement Request \(Without Approval\) Status Transition](#)
- [Payment Agreement Request \(With Approval\) Status Transition](#)
- [Prerequisites](#)
- [Algorithms Used in C1-PaymentAgreementRequest](#)
- [Payment Agreement Request Type](#)
- [Payment Agreement Request \(Used for Searching\)](#)
- [Payment Agreement Request \(Used for Viewing\)](#)

Oracle Revenue Management and Billing provides the ability to schedule payments in installments for a set of unpaid bills of an account through a payment agreement request. Let us understand this with the help of an example. The following bills of the account A1 are unpaid:

- B1 (Bill Amount – 100\$, Unpaid Amount - 75\$)
- B2 (Bill Amount – 250\$, Unpaid Amount – 125\$)
- B3 (Bill Amount – 150\$, Unpaid Amount – 150\$)

Through a payment agreement request, you can schedule payments for these three bills in various installments. For example, you can schedule the following payments for the account A1:

Schedule Date	Schedule Amount
01-Jan-2017	100
15-Jan-2017	100
01-Feb-2017	100
15-Feb-2017	50

While creating a payment agreement request, you need to specify the payment agreement request type using which you want to create the payment agreement request. It is the payment agreement request type which helps the system to determine:

- The business object using which the payment agreement request should be created
- Whether the approval is required for the payment agreement request

You can only add completed bills of the account which are unpaid in a payment agreement request. Once a payment agreement request is created for an account, the status of the payment agreement request is set to **Draft**. You can then edit or delete the payment agreement request, if required. Once you add the unpaid bills of the account, you can submit the payment agreement request. On submitting a payment agreement request, the status of the payment agreement request is set to **Active**.

You can optionally configure the system to use the approval workflow process for a payment agreement request. If the **Approval Required** flag is set to **Yes** in a payment agreement request type, then on submitting the respective payment agreement request, the approval workflow process creates a To Do for the approver to review the payment agreement request. Once the approver approves the payment agreement request, the status of the payment agreement request is set to **Active**. The approver can approve, reject, or resubmit the payment

agreement request. When the payment agreement request is resubmitted to the submitter, the status of the payment agreement request is set to **Draft**.

Even if the approval workflow is configured for a payment agreement request type, you can skip the approval workflow for a payment agreement request. The system enables you to skip the approval workflow for a payment agreement request until you exceed the maximum limit defined in the **C1-PASUBMIT** algorithm. You can define the following parameters in the **C1-PA-SUBMIT** algorithm:

- Number of days to consider in past to check whether any payment agreement request with a particular status exist in the specified duration (for example, 365)
- Maximum number of payment agreement requests which can be activated without approval (for example, 1)
- Status in which payment agreement request should exist in the specified duration (for example, Broken Promise)

In the above example, on clicking the **Submit** button, the system will check how many payment agreement requests for the account in the last 365 days exist in the **Broken Promise** status. If the system finds one or more than one payment agreement requests in the **Broken Promise** status in the last 365 days, the approval workflow process creates a To Do for the approver to review the payment agreement request. However, if the system does not find any payment agreement request in the **Broken Promise** status in the last 365 days, the payment agreement request is not sent for approval and the status of the payment agreement request is directly changed to **Active**.

When the **Payment Agreement Request Periodic Monitor (C1-PAREQ)** batch is invoked, the system checks whether there are any payment agreement requests in the **Active** status. If there is a payment agreement request in the **Active** status, the system checks whether the total unpaid amount of the bills is equal to zero and whether each bill is fully matched. If so, the status of the payment agreement request is changed to **Kept Promise**. However, if the total unpaid amount of the bills is not equal to zero, the system checks whether the current date is later than the schedule date and does not fall within the grace period. If so, the system checks whether total unpaid amount is greater than the total future schedule amount. If so, the status of the payment agreement request is changed to **Broken Promise**. However, if the current date is earlier than the schedule date or falls within the grace period, or the total unpaid amount is less than the total future schedule amount, the status of payment agreement request remains in **Active**. The system enables you to edit a payment agreement request which is in the **Active** status.

While defining a payment agreement request, you need to specify the payment method through which the payment will be done and whether the payment will be done through the payor or third party payor account. If the **Auto Pay** flag is set to **Yes** for a payment method, you need to also specify the automatic payment option using which the automatic payment should be created on the schedule date. One more batch named **Generate Auto Pay for Payment Agreement (C1-APPAB)** is introduced in this release. When the **Generate Auto Pay for Payment Agreement (C1-APPAB)** batch is invoked, the system checks whether there are any payment agreement requests in the **Active** status. If so, whether the account for which the payment agreement request is created is eligible for automatic payment and the defer auto pay date (if any) defined for the account is earlier than the batch business date. If so, the system checks whether the extract date of the unpaid bill (with the earliest due date) is earlier than the schedule date.

If so, the system creates the automatic payment for the unpaid bill on the schedule date. However, if the account is not eligible for automatic payment, or the defer auto pay date is equal to or later than batch business date, or the extract date is equal to or later than the schedule date, the automatic payment is not generated for the account.

During the payment agreement request process, a payment agreement request creation goes through various statuses in its lifecycle. For more information about the payment agreement request statuses, see [Payment Agreement Request \(Without Approval\) Status Transition](#) on page 1712 and [Payment Agreement Request \(With Approval\) Status Transition](#) on page 1712. If the payment agreement request type is without approval then payment agreement status will automatically move from draft to active. The approval configuration algorithm **C1-PA-APPEXT** decides whether the request will be sent for approval or not. If the payment agreement request type is with approval then payment agreement will be sent for approval depending on:

- The number of days checked for approval workflow
- Payment agreement statuses (active, broken, kept) to be considered
- The maximum number of payment agreements allowed

**Note:** The lifecycle of a payment agreement request creation is driven by the respective business object using which the request is created. The payment agreement request feature explained in this document is articulated based on the lifecycle and logic defined in the business objects.

For more information on how to setup the payment agreement request process, see [Prerequisites](#) on page 1713.

## Payment Agreement Request (Without Approval) Status Transition

The following figure graphically indicates how a payment agreement request moves from one status to another when approval workflow is off:

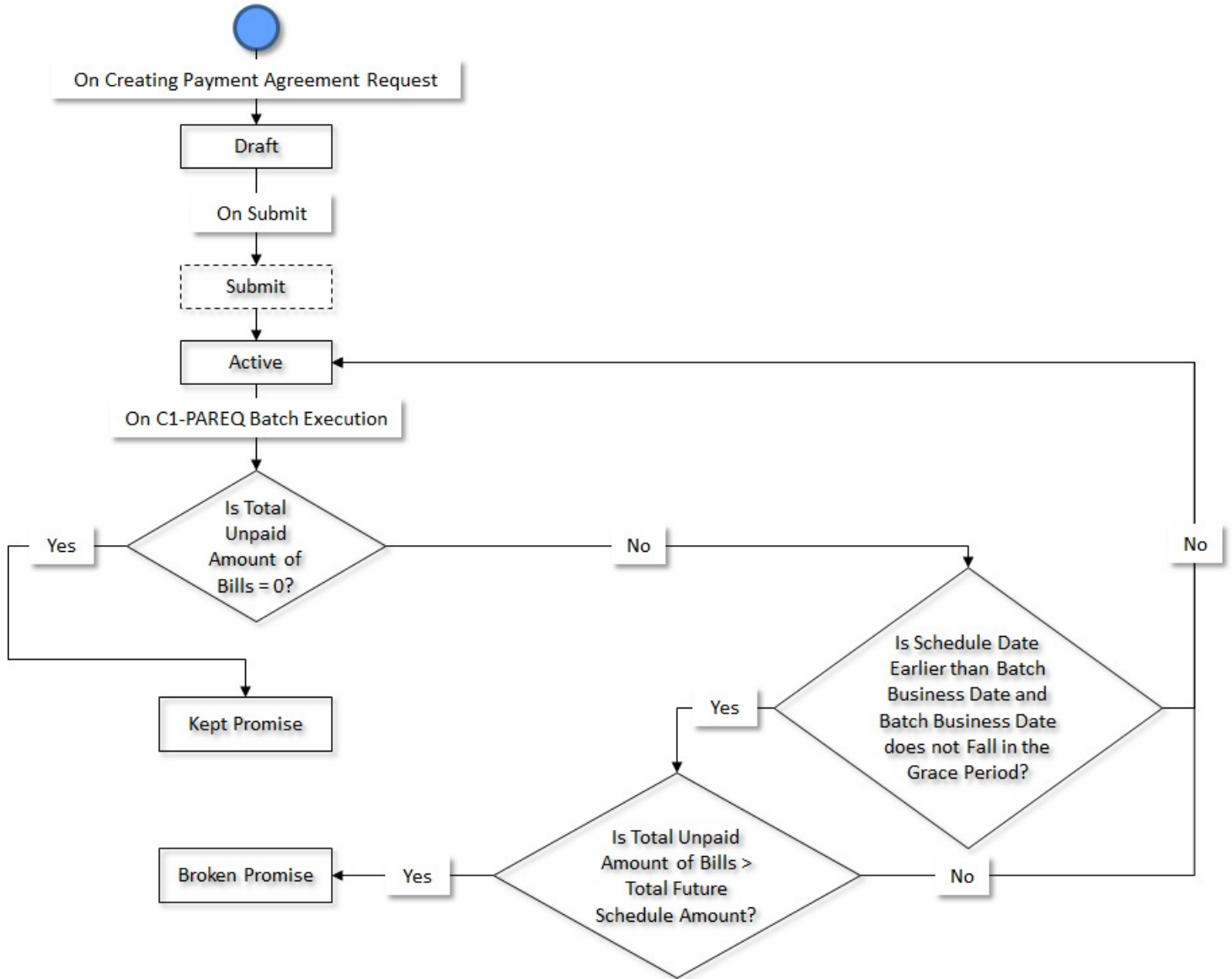

## Payment Agreement Request (With Approval) Status Transition

The following figure graphically indicates how a payment agreement request moves from one status to another when approval workflow is on:



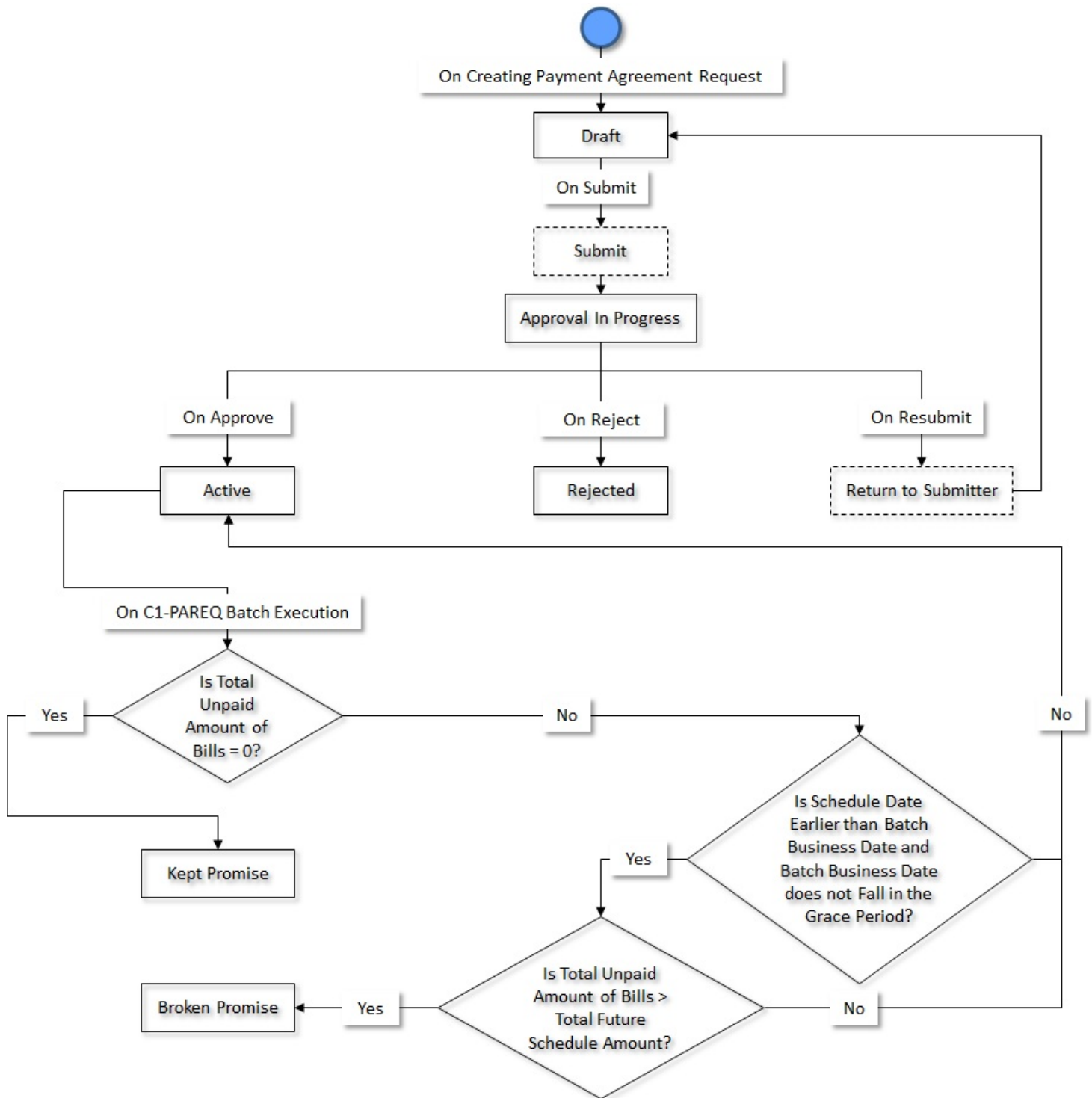

## Prerequisites

To setup the payment agreement request process, you need to do the following:

- Define the required payment agreement request types in the system
- Define the required characteristic types where the characteristic entity is set to **Payment Agreement Request**

- Define the required characteristic types where the characteristic entity is set to **Payment Agreement Request Type**
- Define the required pay methods for **Payment Agreement Request**
- Define the required third party payors for **Payment Agreement Request**
- Create an algorithm using the **C1-PA-INFO** algorithm type if you want to create Payment Agreement Requests using the payment agreement request information.
- Define the kept promise status reason for the **C1-PaymentAgreementRequest** business object
- Define the broken promise status reason for the **C1-PaymentAgreementRequest** business object
- Defined rejected status reason for the **C1-PaymentAgreementRequest** business object
- Assign the **C1-PAREQ** To Do type to a To Do role whose users must receive To Do generated while submitting or resubmitting a payment agreement request for approval
- The **Payment Agreement Request Periodic Monitor (C1-PAREQ)** batch process to monitor the payment agreement request and move the request to next stage

## Algorithms Used in C1-PaymentAgreementRequest

The following table lists the algorithms which are attached to the **C1-PaymentAgreementRequest** business object:

System Event	Algorithm	Algorithm Type	Description
Information	C1-PA-INFO	C1-PA-INFO	Refer to <a href="#">C1-PA-INFO</a>
Pre-Processing	C1-PA-PRE	C1-PA-PRE	<a href="#">C1-PA-PRE</a>
Validation	C1-PA-VAL	C1-PA-VAL	<a href="#">C1-PA-VAL</a>

The following table lists the algorithms which are used in the lifecycle of the **C1-PaymentAgreementRequest** business object:

Status	System Event	Algorithm	Algorithm Type	Description
Submit	Enter	C1-PA-SUBMIT	C1-PA-SUBMIT	<a href="#">C1-PA-SUBMIT</a>
Approval In Progress	Enter	C1-PA-APPENT	C1-PA-APPENT	<a href="#">C1-PA-APPENT</a>
Approval In Progress	Exit	C1-PA-APPEXT	C1-PA-APPEXT	<a href="#">C1-PA-APPEXT</a>
Return to Submitter	Enter	C1-PA-RESUB	C1-PA-RESUB	<a href="#">C1-PA-RESUB</a>
Active	Monitor	C1-PA-MONTR	C1-PA-MONTR	<a href="#">C1-MONTR</a>
Active	Enter	C1-PA-ACTENT	C1-PA-ACTENT	<a href="#">C1-ACTENT</a>

## Payment Agreement Request Type

Oracle Revenue Management and Billing allows you to define, edit, copy and delete a payment agreement request type using which you can pay current unpaid debt bills in multiple installments whose payment amount is greater than zero. A payment agreement provide flexibility in payment of installment amount and schedule of payment.



The **C1-PaymentAgreementRequest** business object is created for payment agreement maintenance.

The **Payment Agreement Request Type** screen consists of the following zones:

- [Payment Agreement Request Type List](#) on page 1715
- [Payment Agreement Request Type](#) on page 1715

## Payment Agreement Request Type List

The **Payment Agreement Request Type List** zone lists payment agreement request types that are already defined in the system. It contains the following columns:

Column Name	Column Description
Payment Agreement Request Type	Displays the payment agreement request type.
Description	Displays the description of the payment agreement request type.
Edit	On clicking the <b>Edit</b> (  ) icon, the <b>Payment Agreement Request Type</b> screen appears where you can edit the details of the payment agreement request type.
Duplicate	On clicking the <b>Duplicate</b> (  ) icon, the <b>Payment Agreement Request Type</b> screen appears where you can define a payment agreement request type using an existing payment agreement request type.
Delete	On clicking the <b>Delete</b> (  ) icon, you can delete the payment agreement request type.  <b>Note:</b> You can delete a payment agreement request type only when you have not created a payment agreement request using the payment agreement request type.

On clicking the **Broadcast** () icon corresponding to a payment agreement request type, the **Payment Agreement Request Type** zone appears with the details of the respective payment agreement request type.

### Related Topics

For more information on...	See...
How to define a payment agreement request type	<a href="#">Defining a Payment Agreement Request Type</a> on page 1718
How to define characteristics for a payment agreement request type	<a href="#">Defining Characteristics for a Payment Agreement Request Type</a> on page 1721
How to edit a payment agreement request type	<a href="#">Editing a Payment Agreement Request Type</a> on page 1722
How to copy a payment agreement request type	<a href="#">Copying a Payment Agreement Request Type</a> on page 1724
How to delete a payment agreement request type	<a href="#">Deleting a Payment Agreement Request Type</a> on page 1726
How to view the details of a payment agreement request type	<a href="#">Viewing the Payment Agreement Request Type Details</a> on page 1727

## Payment Agreement Request Type

The **Payment Agreement Request Type** zone displays the details of the payment agreement request type. This zone contains the following sections:

- **Main** – This section provides basic information about the payment agreement request type. It contains the following fields:

Field Name	Field Description
Payment Agreement Request Type	Displays the payment agreement request type.
Description	Displays the description of the payment agreement request type.
Payment Agreement Request Business Object	<p>Indicates the business object that will be used to create the payment agreement request. In addition, a context menu appears corresponding to this field which helps in navigating to other screens in the application.</p> <p><b>Note:</b> It has a link. On clicking the link, the <b>Business Object</b> screen appears where you can view the details of the respective business object.</p>
Detailed Description	Displays additional information about the payment agreement request type.
Status	<p>Indicates the status of the payment agreement request type. The valid values are:</p> <ul style="list-style-type: none"> <li>• Active</li> <li>• Inactive</li> </ul>
Status Change Notification Type	<p>Indicates the notification type on the status change of payment agreement request type. The valid values are:</p> <ul style="list-style-type: none"> <li>• Alert</li> <li>• To Do</li> <li>• Both</li> </ul>
Approval Required	Indicates whether approval is required while creating payment agreement request using the payment agreement request type.
Approval To Do Type	<p>Indicates that the To Do entry of the specified To Do type must be created when you submit the payment agreement request for approval.</p> <p><b>Note:</b></p> <p>This field appears only when the <b>Approval Required</b> check box is selected. It has a link. On clicking the link, the <b>To Do Type</b> screen appears with the details of the respective To Do type.</p> <p>The <b>Search</b>  icon appears corresponding to this field. On clicking the <b>Search</b> icon, the <b>To Do Type Search</b> window appears.</p>
Approval To Do Role	<p>Indicates that users with the specified To Do role can only approve or reject the payment agreement request submitted for approval.</p> <p><b>Note:</b></p> <p>This field appears only when the <b>Approval Required</b> check box is selected. It has a link. On clicking the link, the <b>To Do Role</b> screen appears with the details of the respective To Do role.</p>

Field Name	Field Description
Submitter To Do Type	<p>Indicates the To Do type for the submitter when the payment agreement request type is resubmitted by the approver.</p> <p><b>Note:</b> This field appears only when the <b>Approval Required</b> check box is selected. It has a link. On clicking the link, the <b>To Do Type</b> screen appears with the details of the respective To Do type.</p> <p>The <b>Search</b>  icon appears corresponding to this field. On clicking the <b>Search</b> icon, the <b>To Do Type Search</b> window appears.</p>
Submitter To Do Role	<p>Indicates the To Do role of the submitter when the payment agreement request type is resubmitted by the approver.</p> <p><b>Note:</b> This field appears only when the <b>Approval Required</b> check box is selected. It has a link. On clicking the link, the <b>To Do Role</b> screen appears with the details of the respective To Do role.</p>

- **Characteristics** – This section lists the characteristics defined for the payment agreement request type. It contains the following columns:

Column Name	Column Description	Mandatory (Yes Or No)
Characteristic Type	Indicates the characteristic type.	No
Characteristic Value	Displays the value of the characteristic type.	No

- **Record Actions** – This section contains the following buttons:

Button Name	Button Description
Edit	Used to edit the details of the payment agreement request type.
Delete	<p>Used to delete the payment agreement request type.</p> <p><b>Note:</b> You can delete a payment agreement request type only when you have not created a payment agreement request using the payment agreement request type.</p>
Duplicate	Used to create a new payment agreement request type using an existing payment agreement request type.

- **Record Information** – This section contains the following fields:

Field Name	Field Description
Business Object	Indicates the business object using which the payment agreement request type is created. In addition, a context menu appears corresponding to this field which helps in navigating to other screens in the application.  <b>Note:</b> It has a link. On clicking the link, the <b>Business Object</b> screen appears where you can view the details of the respective business object.

By default, the **Payment Agreement Request Type** zone does not appear in the **Payment Agreement Request Type** screen. It appears only when you click the **Broadcast**  icon corresponding to a payment agreement request type in the **Payment Agreement Request Type List** zone.

### Related Topics

For more information on...	See...
How to define a payment agreement request type	<a href="#">Defining a Payment Agreement Request Type</a> on page 1718
How to define characteristics for a payment agreement request type	<a href="#">Defining Characteristics for a Payment Agreement Request Type</a> on page 1721
How to edit a payment agreement request type	<a href="#">Editing a Payment Agreement Request Type</a> on page 1722
How to copy a payment agreement request type	<a href="#">Copying a Payment Agreement Request Type</a> on page 1724
How to delete a payment agreement request type	<a href="#">Deleting a Payment Agreement Request Type</a> on page 1726
How to view the details of a payment agreement request type	<a href="#">Viewing the Payment Agreement Request Type Details</a> on page 1727

## Defining a Payment Agreement Request Type

### Prerequisites

To define a payment agreement request type, you should have:

- Payment agreement request business objects defined in the application
- The Payment Agreement Request Information algorithm is defined using the **C1-PA-INFO** algorithm type
- **C1-PAREQ** To Do Type assigned to a To Do role whose users must receive To Do generated while submitting a payment agreement request for approval.

### Procedure

To define a payment agreement request type:

1. Click the **Admin** link in the **Application** toolbar.  
A list appears.
2. From the **Admin** menu, select **P** and then click **Payment Agreement Request Type**.  
A sub-menu appears.
3. Click the **Add** option from the **Payment Agreement Request Type** sub-menu.  
The **Select Business Object** screen appears. It contains the following field:

Field Name	Field Description	Mandatory (Yes or No)
Payment Agreement Request Type Business Object	Used to indicate the business object that you want to use to create the payment agreement request type.	Yes

**Tip:** Alternatively, you can access the **Select Business Object** screen by clicking the **Add** button in the **Page Title** area of the **Payment Agreement Request Type** screen.

**Note:** The **Select Business Object** screen appears only when there are multiple payment agreement request type business objects defined in the application. If there is only one payment agreement request type business object defined in the application, the **Payment Agreement Request Type** screen appears.

4. Select the required payment agreement request type business object from the respective field.
5. Click **OK**.

The **Payment Agreement Request Type** screen appears. It contains the following sections:

- **Main** – Used to specify basic details about the payment agreement request type.
- **Characteristics** – Used to define characteristics for the payment agreement request type.

The **Main** section contains the following fields:

Field Name	Field Description	Mandatory (Yes or No)
Payment Agreement Request Type	Used to specify the payment agreement request type.	Yes
Business Object	Indicates the payment agreement request type business object used while defining the payment agreement request type.	Not applicable
Description	Used to specify the description for the payment agreement request type.	Yes
Payment Agreement Request Business Object	Used to indicate the business object that you want to use while creating the payment agreement request.	Yes
Detailed Description	Used to specify additional information about the payment agreement request type.	No
Status	Used to indicate the status of the payment agreement request type. The valid values are: <ul style="list-style-type: none"> <li>• Active</li> <li>• Inactive</li> </ul>	Yes
Status Change Notification Type	Used to indicate the notification type on the status change of payment agreement request type. The valid values are: <ul style="list-style-type: none"> <li>• Alert</li> <li>• To Do</li> <li>• Both</li> </ul>	No

Field Name	Field Description	Mandatory (Yes or No)
Approval Required	Used to indicate whether approval is required for creating payment agreement request using the payment agreement request type.	No
Approval To Do Type	Used to indicate that To Do of the specified To Do type must be created when you submit the payment agreement request for approval. <b>Note:</b> This field appears only when the <b>Approval Required</b> check box is selected.	Yes (Conditional) <b>Note:</b> This field is required only when the <b>Approval Required</b> option is selected.
Approval To Do Role	Used to indicate that users with the specified To Do role can only approve the payment agreement request submitted for approval. <b>Note:</b> This field appears only when the <b>Approval Required</b> check box is selected.	Yes (Conditional) <b>Note:</b> This field is required only when the <b>Approval Required</b> option is selected. The list will include only those To Do roles which are associated with the To Do type specified in the <b>Approval To Do Type</b> field.
Submitter To Do Type	Used to indicate the To Do type for the submitter when the payment agreement request is resubmitted by the approver. <b>Note:</b> This field appears only when the <b>Approval Required</b> check box is selected.	Yes (Conditional) <b>Note:</b> This field is required only when the <b>Approval Required</b> option is selected.
Submitter To Do Role	Used to indicate the To Do role for the submitter when the payment agreement request is resubmitted by the approver. <b>Note:</b> This field appears only when the <b>Approval Required</b> check box is selected.	Yes (Conditional) <b>Note:</b> This field is required only when the <b>Approval Required</b> option is selected. The list will include only those To Do roles which are associated with the To Do type specified in the <b>Submitter To Do Type</b> field.

6. Enter the required details.
7. Define characteristics for the payment agreement request type, if required.
8. Click **Save**.

The payment agreement request type is defined.

#### **Related Topics**

For more information on...	See...
Payment Agreement Request Type screen	<a href="#">Payment Agreement Request Type</a> on page 1714



<b>For more information on...</b>	<b>See...</b>
<b>Payment Agreement Request Type List zone</b>	<a href="#">Payment Agreement Request Type List</a> on page 1715
How to define characteristics for a payment agreement request type	<a href="#">Defining Characteristics for a Payment Agreement Request Type</a> on page 1721

## Defining Characteristics for a Payment Agreement Request Type

### Prerequisites

To define characteristics for a payment agreement request type, you should have:

- Characteristic types defined in the application (where the characteristic entity is set to Payment Agreement Request Type)

### Procedure

To define characteristics for a payment agreement request type:

1. Ensure that the **Characteristics** section is expanded when you are defining, editing, or copying a payment agreement request type.

The **Characteristics** section contains the following fields:

Field Name	Field Description	Mandatory (Yes or No)
Characteristic Type	Used to indicate the characteristic type.  <b>Note:</b> The list includes only those characteristic types where the characteristic entity is set to Payment Agreement Request Type.	Yes (Conditional)  <b>Note:</b> This field is required when you are defining a characteristic for the payment agreement request type.
Characteristic Value	Used to specify the value for the characteristic type.  <b>Note:</b> On specifying the value for a predefined characteristic type, the description of the characteristic value appears corresponding to the <b>Characteristic Value</b> field.	Yes (Conditional)  <b>Note:</b> This field is required when you are defining a characteristic for the payment agreement request type.

2. Enter the required details.

**Note:** If you select a predefined characteristic type, the **Search**  icon appears corresponding to the **Characteristic Value** field. On clicking the **Search** icon, you can search for a predefined characteristic value.

3. If you want to define more than one characteristic for the payment agreement request type, click the **Add**  icon and then repeat step 2.

**Note:** However, if you want to remove a characteristic from the payment agreement request type, click the **Delete**  icon corresponding to the characteristic.

### Related Topics

For more information on...	See...
How to define a payment agreement request type	<a href="#">Defining a Payment Agreement Request Type</a> on page 1718
How to edit a payment agreement request type	<a href="#">Editing a Payment Agreement Request Type</a> on page 1722
How to copy a payment agreement request type	<a href="#">Copying a Payment Agreement Request Type</a> on page 1724

## Editing a Payment Agreement Request Type

### Prerequisites

To edit a payment agreement request type, you should have:

- Payment agreement request business objects defined in the application
- The Payment Agreement Request Information algorithm is defined using the **C1-PA-INFO** algorithm type
- **C1-PAREQ** To Do Type assigned to a To Do role whose users must receive To Do generated while submitting a payment agreement request for approval.

### Procedure

To edit a payment agreement request type:



1. Click the **Admin** link in the **Application** toolbar.  
A list appears.
2. From the **Admin** menu, select **P** and then click **Payment Agreement Request Type**.  
A sub-menu appears.
3. Click the **Search** option from the **Payment Agreement Request Type** sub-menu.  
The **Payment Agreement Request Type** screen appears.
4. In the **Payment Agreement Request Type List** zone, click the **Edit** (✎) icon in the **Edit** column corresponding to the payment agreement request type whose details you want to edit.

The **Payment Agreement Request Type** screen appears. It contains the following sections:

- **Main** – Used to specify basic details about the payment agreement request type.
- **Characteristics** – Used to define characteristics for the payment agreement request type.

The **Main** section contains the following fields:

Field Name	Field Description	Mandatory (Yes or No)
Payment Agreement Request Type	Displays the payment agreement request type.	Not applicable
Business Object	Indicates the payment agreement request type business object used while defining the payment agreement request type.	Not applicable
Description	Used to specify the description for the payment agreement request type.	Yes
Upload Request Business Object	Used to specify the business object that you want to use while creating the payment agreement request.	Yes
Detailed Description	Used to specify additional information about the payment agreement request type.	No

Field Name	Field Description	Mandatory (Yes or No)
Status	Used to indicate the status of the payment request type. The valid values are: <ul style="list-style-type: none"> <li>Active</li> <li>Inactive</li> </ul>	Yes
Status Change Notification Type	Used to indicate the notification type on the status change of payment agreement request type. The valid values are: <ul style="list-style-type: none"> <li>Alert</li> <li>To Do</li> <li>Both</li> </ul>	No
Approval Required	Used to indicate whether approval is required for editing payment agreement request using the payment agreement request type.	Yes
Approval To Do Type	Used to indicate that To Do of the specified To Do type must be created when you submit the payment agreement request for approval. <p><b>Note:</b> The <b>Search</b>  icon appears corresponding to this field. On clicking the <b>Search</b> icon, the <b>To Do Type Search</b> window appears.</p>	Yes (Conditional) <p><b>Note:</b> This field is required when the <b>Approval Required</b> check box is selected.</p>
Approval To Do Role	Used to indicate that users with the specified To Do role can only approve the upload request submitted for approval. <p><b>Note:</b> This field appears only when the <b>Approval Required</b> check box is selected.</p>	Yes (Conditional) <p><b>Note:</b> This field is required when the <b>Approval Required</b> check box is selected.</p>
Submitter To Do Type	Used to indicate the To Do type for the submitter when the payment agreement request is resubmitted by the approver. <p><b>Note:</b> This field appears only when the <b>Approval Required</b> check box is selected.</p> <p>The <b>Search</b>  icon appears corresponding to this field. On clicking the <b>Search</b> icon, the <b>To Do Type Search</b> window appears</p>	Yes (Conditional) <p><b>Note:</b> This field is required when the <b>Approval Required</b> check box is selected.</p>
Submitter To Do Role	Used to indicate the To Do role for the submitter when the payment agreement request is resubmitted by the approver. <p><b>Note:</b> This field appears only when the <b>Approval Required</b> check box is selected.</p>	Yes (Conditional) <p><b>Note:</b> This field is required when the <b>Approval Required</b> check box is selected.</p>

**Tip:** Alternatively, you can click the **Edit** button in the **Payment Agreement Request Type** zone to edit the details of the payment agreement request type.

5. Modify the required details.

**Note:** You can search for a **Approval To Do Type** and **Submitter To Do Type** by clicking the **Search**  icon corresponding to the respective field.

6. Define, edit, or remove characteristics from the payment agreement request type, if required.
7. Click **Save**.

The changes made to the payment agreement request type are saved.

### Related Topics

For more information on...	See...
<b>Payment Agreement Request Type</b> screen	<a href="#">Payment Agreement Request Type</a> on page 1714
<b>Payment Agreement Request Type List</b> zone	<a href="#">Payment Agreement Request Type List</a> on page 1715
<b>Payment Agreement Request Type</b> zone	<a href="#">Payment Agreement Request Type</a> on page 1715
How to define characteristics for a payment agreement request type	<a href="#">Defining Characteristics for a Payment Agreement Request Type</a> on page 1721

## Copying a Payment Agreement Request Type

Instead of creating a payment agreement request type from scratch, you can create a new payment agreement request type using an existing payment agreement request type. This is possible through copying a payment agreement request type. On copying a payment agreement request type, the details including the characteristics are copied to the new payment agreement request type. You can then edit the details, if required.

### Prerequisites

To copy a payment agreement request type, you should have:

- Payment agreement request type (whose copy you want to create) defined in the application
- Payment agreement request business objects defined in the application
- The Payment Agreement Request Information algorithm is defined using the **C1-PA-INFO** algorithm type
- **C1-PAREQ** To Do Type assigned to a To Do role whose users must receive To Do generated while submitting a payment agreement request for approval

### Procedure

To copy a payment agreement request type:

1. Click the **Admin** link in the **Application** toolbar.  
A list appears.
2. From the **Admin** menu, select **P** and then click **Payment Agreement Request Type**.  
A sub-menu appears.
3. Click the **Search** option from the **Payment Agreement Request Type** sub-menu.  
The **Payment Agreement Request Type** screen appears.
4. In the **Payment Agreement Request Type List** zone, click the **Duplicate**  icon in the **Duplicate** column corresponding to the payment agreement request type whose copy you want to create.

The **Payment Agreement Request Type** screen appears. It contains the following sections:

- **Main** – Used to specify basic details about the payment agreement request type.
- **Characteristics** – Used to define characteristics for the payment agreement request type.

The **Main** section contains the following fields:

Field Name	Field Description	Mandatory (Yes or No)
Payment Agreement Request Type	Used to specify the payment agreement request type.	Yes
Business Object	Indicates the payment agreement request type business object used while defining the payment agreement request type (whose copy you want to create).	Not applicable
Description	Used to specify the description for the payment agreement request type.	Yes
Payment Agreement Request Business Object	Used to specify the business object that you want to use while creating the payment agreement request.	Yes
Detailed Description	Used to specify additional information about the payment agreement request type.	No
Status	Used to indicate the status of the payment agreement request type. The valid values are: <ul style="list-style-type: none"> <li>• Active</li> <li>• Inactive</li> </ul>	Yes
Status Change Notification Type	Used to indicate the notification type on the status change of payment agreement request type. The valid values are: <ul style="list-style-type: none"> <li>• Alert</li> <li>• To Do</li> <li>• Both</li> </ul>	No
Approval Required	Used to indicate whether approval is required while creating payment agreement request using the payment agreement request type.	Yes
Approval To Do Type	Used to indicate that To Do of the specified To Do type must be created when you submit the payment agreement request for approval. <div style="border: 1px solid black; padding: 5px; margin-top: 10px;"> <p><b>Note:</b> This field appears only when the <b>Approval Required</b> check box is selected.</p> <p>The <b>Search</b>  icon appears corresponding to this field. On clicking the <b>Search</b> icon, the <b>To Do Type Search</b> window appears.</p> </div>	Yes (Conditional) <div style="border: 1px solid black; padding: 5px; margin-top: 10px;"> <p><b>Note:</b> This field is required when the <b>Approval Required</b> check box is selected.</p> </div>

Field Name	Field Description	Mandatory (Yes or No)
Approval To Do Role	Used to indicate that users with the specified To Do role can only approve the payment agreement request submitted for approval.  <b>Note:</b> This field appears only when the <b>Approval Required</b> check box is selected.	Yes (Conditional)  <b>Note:</b> This field is required when the <b>Approval Required</b> check box is selected.
Submitter To Do Type	Used to indicate the To Do type for the submitter when the payment agreement request is resubmitted by the approver.  <b>Note:</b> This field appears only when the <b>Approval Required</b> check box is selected.  The <b>Search</b>  icon appears corresponding to this field. On clicking the <b>Search</b> icon, the <b>To Do Type Search</b> window appears.	Yes (Conditional)  <b>Note:</b> This field is required when the <b>Approval Required</b> check box is selected.
Submitter To Do Role	Used to indicate the To Do role for the submitter when the payment agreement request is resubmitted by the approver.  <b>Note:</b> This field appears only when the <b>Approval Required</b> check box is selected.	Yes (Conditional)  <b>Note:</b> This field is required when the <b>Approval Required</b> check box is selected.

**Tip:** Alternatively, you can click the **Duplicate** button in the **Payment Agreement Request Type** zone to create a copy of the payment agreement request type.

5. Enter the required details.
6. Define, edit, or remove characteristics from the payment agreement request type, if required.
7. Click **Save**.

The new payment agreement request type is defined.

### **Related Topics**

For more information on...	See...
<b>Payment Agreement Request Type</b> screen	<a href="#">Payment Agreement Request Type</a> on page 1714
<b>Payment Agreement Request Type List</b> zone	<a href="#">Payment Agreement Request Type List</a> on page 1715
<b>Payment Agreement Request Type</b> zone	<a href="#">Payment Agreement Request Type</a> on page 1715
How to define characteristics for a payment agreement request type	<a href="#">Defining Characteristics for a Payment Agreement Request Type</a> on page 1721

## **Deleting a Payment Agreement Request Type**

### **Procedure**

To delete a payment agreement request type:

1. Click the **Admin** link in the **Application** toolbar.

A list appears.

- From the **Admin** menu, select **P** and then click **Payment Agreement Request Type**.

A sub-menu appears.

- Click the **Search** option from the **Payment Agreement Request Type** sub-menu.

The **Payment Agreement Request Type** screen appears.

- In the **Payment Agreement Request Type List** zone, click the **Delete** () icon in the **Delete** column corresponding to the payment agreement request type that you want to delete.

A message appears confirming whether you want to delete the payment agreement request type.

**Note:** You can delete a payment agreement request type only when you have not created a payment agreement request using the payment agreement request type.

**Tip:** Alternatively, you can click the **Delete** button in the **Payment Agreement Request Type** zone to delete the payment agreement request type.

- Click **OK**.

The payment agreement request type is deleted.

### Related Topics

For more information on...	See...
<b>Payment Agreement Request Type</b> screen	<a href="#">Payment Agreement Request Type</a> on page 1714
<b>Payment Agreement Request Type List</b> zone	<a href="#">Payment Agreement Request Type List</a> on page 1715
<b>Payment Agreement Request Type</b> zone	<a href="#">Payment Agreement Request Type</a> on page 1715

## Viewing the Payment Agreement Request Type Details

### Procedure

To view the details of a payment agreement request type:

- Click the **Admin** link in the **Application** toolbar.

A list appears.

- From the **Admin** menu, select **P** and then click **Payment Agreement Request Type**.

A sub-menu appears.

- Click the **Search** option from the **Payment Agreement Request Type** sub-menu.

The **Payment Agreement Request Type** screen appears.

- In the **Payment Agreement Request Type List** zone, click the **Broadcast** () icon corresponding to the payment agreement request type whose details you want to view.

The **Payment Agreement Request Type** zone appears.

- View the details of the payment agreement request type in the **Payment Agreement Request Type** zone.

### Related Topics

For more information on...	See...
<b>Payment Agreement Request Type</b> screen	<a href="#">Payment Agreement Request Type</a> on page 1714

For more information on...	See...
Payment Agreement Request Type List zone	<a href="#">Payment Agreement Request Type List</a> on page 1715
Payment Agreement Request Type zone	<a href="#">Payment Agreement Request Type</a> on page 1715

## Payment Agreement Request (Used for Searching)

The **Payment Agreement Request** screen allows you to search for a payment agreements for unpaid bills by searching through Bill ID or through Payment Agreement Request ID. Through this screen, you can navigate to the following screens:

- [Payment Agreement Request \(Used for Viewing\)](#) on page 1736

This screen consists of the following zones:

- [Search Payment Agreement Request](#) on page 1728
- [Bill Details](#) on page 1731



## Search Payment Agreement Request

The **Search Payment Agreement Request** zone allows you to search for a payment agreement request using various search criteria. This zone contains the following two sections:

- **Search Criteria** – The **Search Criteria** section contains the following fields:

Field Name	Field Description	Mandatory (Yes or No)
Search By	Used to indicate whether you want to search for a payment agreement request using request or bill details. The valid values are: <ul style="list-style-type: none"> <li>• Request Details</li> <li>• Bill Details</li> </ul> <div style="border: 1px solid black; padding: 2px; margin-top: 5px;"><b>Note:</b> By default, the <b>Request Details</b> option is selected.</div>	Yes
Payment Agreement Request ID	Used to search a particular payment agreement request. <div style="border: 1px solid black; padding: 2px; margin-top: 5px;"><b>Note:</b> This field appears only when you select the <b>Request Details</b> option from the <b>Search By</b> list.</div>	No
Created From	Used to search payment agreement requests which are created from a particular date onwards. <div style="border: 1px solid black; padding: 2px; margin-top: 5px;"><b>Note:</b> This field appears only when you select the <b>Request Details</b> option from the <b>Search By</b> list.</div>	No
To	Used to search payment agreement requests which are created till a particular date. <div style="border: 1px solid black; padding: 2px; margin-top: 5px;"><b>Note:</b> This field appears only when you select the <b>Request Details</b> option from the <b>Search By</b> list.</div>	No



Field Name	Field Description	Mandatory (Yes or No)
Payment Agreement Request Type	Used to search payment agreement requests which are created using a particular payment agreement request type.  <b>Note:</b> This field appears only when you select the <b>Request Details</b> option from the <b>Search By</b> list.	No
Status	Used to search payment agreement requests with a particular status. The valid values are: <ul style="list-style-type: none"> <li>• Active</li> <li>• Approval In Progress</li> <li>• Broken Promise</li> <li>• Draft</li> <li>• Kept Promise</li> <li>• Rejected</li> <li>• Return to Submitter</li> </ul> <b>Note:</b> This field appears only when you select the <b>Request Details</b> option from the <b>Search By</b> list.	No
Account ID	Used to search for unpaid bills of a particular account.  <b>Note:</b> This field appears only when you select the <b>Request Details</b> option from the <b>Search By</b> list. You can search for a account ID by clicking the <b>Search</b>  icon corresponding to the field.	No
Person ID	Used to search the person ID based on which you want to search for bills of a person.  <b>Note:</b> This field appears only when you select the <b>Request Details</b> option from the <b>Search By</b> list. You can search for a person ID by clicking the <b>Search</b>  icon corresponding to the field.	No
Bill ID	Used to search a particular bill.  <b>Note:</b> This field appears only when you select the <b>Bill Details</b> option from the <b>Search By</b> list. You can search for a bill by clicking the <b>Search</b>  icon corresponding to the field.	No

Field Name	Field Description	Mandatory (Yes or No)
Bill Date From	Used to search bills which are created from a particular date onwards.  <b>Note:</b> This field appears only when you select the <b>Bill Details</b> option from the <b>Search By</b> list.	No
To	Used to search bills which are created till a particular date.  <b>Note:</b> This field appears only when you select the <b>Bill Details</b> option from the <b>Search By</b> list.	No
Alternate Bill ID	Used to search a particular bill using the alternate bill ID.  <b>Note:</b> This field appears only when you select the <b>Bill Details</b> option from the <b>Search By</b> list.	No

**Note:** You must specify at least one search criterion while searching for a payment agreement request.

- **Search Results** – On clicking the **Search** button, the search results appear based on the specified search criteria. The **Search Results** section contains the following columns:

Column Name	Column Description
Create Date/Time	Displays the date and time when the payment agreement request was created in the system.
Payment Agreement Request Information	Displays information about the payment agreement request.  <b>Note:</b> It has a link. On clicking the link, the <b>Payment Agreement Request</b> screen appears where you can view the details of the respective payment agreement request.
Schedule Amount	Displays the amount that the customer has agreed to pay on the scheduled date.
Status	Indicates the status of the payment agreement request. The valid values are: <ul style="list-style-type: none"> <li>• Active</li> <li>• Approval In Progress</li> <li>• Broken Promise</li> <li>• Draft</li> <li>• Kept Promise</li> <li>• Rejected</li> <li>• Return to Submitter</li> </ul>
Last Updated Date/Time	Displays the most recent updated date and time of the payment agreement request.
Total Unpaid Amount	Displays the total unpaid amount for debit bills.  <b>Note:</b> <b>Total Unpaid Amount</b> should be equal to total <b>Schedule Amount</b> .

Column Name	Column Description
Person Information	Displays information about the person. In addition, this column has a context menu which helps in navigating to other screens in the application.  <b>Note:</b> It has a link. On clicking the link, the <b>Person</b> screen appears where you can view the details of the respective person.
Account Information	Displays information about the account. In addition, this column has a context menu which helps in navigating to other screens in the application.  <b>Note:</b> It has a link. On clicking the link, the <b>Account</b> screen appears where you can view the details of the respective account.

**Note:** Pagination is used to display limited number of records in the **Search Results** section. You can use the navigation links, such as **Previous** and **Next** to navigate between pages.

### Related Topics

For more information on...	See...
How to search for a payment agreement request	<a href="#">Searching for a Payment Agreement Request</a> on page 1732
How to create a payment agreement request	<a href="#">Creating a Payment Agreement Request</a> on page 1732
How to view the details of a payment agreement request	<a href="#">Viewing the Payment Agreement Request Details</a> on page 1736

### Bill Details

The **Bill Details** zone lists unpaid debt bill details. You will not find any records in this zone if the payment agreement request list does not have any unpaid bills assigned to it. This zone contains the following columns:

Column Name	Column Description
Bill Information	Indicates the bill against which the payment agreement request is created. In addition, this column has a context menu which helps in navigating to other screens in the application.  <b>Note:</b> It has a link. On clicking the link, the <b>Bill</b> screen appears with the details of the respective bill.
Original Bill Amount	Displays the bill amount when the bill was generated.
Current Bill Balance	Displays the outstanding amount.
Due Date	Displays the due date of the bill.

By default, the **Bill Details** zone does not appear in the **Payment Agreement Request** screen. It appears only when you click the **Broadcast**  icon corresponding to the payment agreement request in the **Search Payment Agreement Request** zone.

You can change the layout of this zone. For more information on how to change the layout, see [Changing the Layout](#) on page 2882.

### Related Topics

For more information on...	See...
How to view bills added in the payment agreement request	<a href="#">Viewing the Bills Added in the Payment Agreement Request</a> on page 1735

## Searching for a Payment Agreement Request

### Prerequisites

To search for a payment agreement request, you should have:

- Payment agreement request types defined in the application

### Procedure

To search for a payment agreement request:

1. Click the **Menu** link in the **Application** toolbar.  
A list appears.
2. From the **Main** menu, select **Credit & Collection** and then click **Payment Agreement Request**.  
A sub-menu appears.
3. Click the **Search** option from the **Payment Agreement Request** sub-menu.  
The **Payment Agreement Request** screen appears.
4. Enter the search criteria in the **Search Payment Agreement Request** zone.

**Note:** ORMB search engine supports wildcard search, where you can substitute the percentage (%) symbol as a stand in for any word or letter in a search criteria. You can use the ‘%’ wildcard character in all input fields except the date and ID fields. The ‘%’ wildcard character is suffixed automatically at the end of the partial search criteria. Therefore, you may or may not specify the wildcard character at the end of the partial search criteria. However, you have to prefix the wildcard character manually wherever required.

5. Click **Search**.

A list of payment agreement requests that meet the search criteria appears in the **Search Results** section.

### Related Topics

For more information on...	See...
<b>Payment Agreement Request</b> screen	<a href="#">Payment Agreement Request (Used for Searching)</a> on page 1728
<b>Search Payment Agreement Request</b> zone	<a href="#">Search Payment Agreement Request</a> on page 1728

## Creating a Payment Agreement Request

### Prerequisites

To create a payment agreement request, you should have:

- Payment agreement request types defined in the application

### Procedure

To create a payment agreement request:

1. Click the **Menu** link in the **Application** toolbar.  
A list appears.
2. From the **Main** menu, select **Credit & Collection** and then click **Payment Agreement Request**.

A sub-menu appears.

3. Click the **Add** option from the **Payment Agreement Request** sub-menu.

The **Add Payment Agreement Request** screen appears. It contains the following fields:

Field Name	Field Description	Mandatory (Yes or No)
Payment Agreement Request Type	Used to indicate the payment agreement request type using which you want to create the payment agreement request.	Yes
Account ID	Used to search for unpaid bills of a particular account.  The <b>Search</b>  icon appears corresponding to this field. On clicking the <b>Search</b> icon, the <b>Account Search</b> window appears.	Yes

**Tip:** Alternatively, you can access the **Add Payment Agreement Request** screen by clicking the **Add** button in the **Page Title** area of the **Payment Agreement Request** screen.

4. Select the required payment agreement request type and account ID from the respective fields.
5. Click **OK**.

The **Payment Request** screen appears.

#### Related Topics

For more information on...	See...
Search Payment Agreement Request zone	<a href="#">Search Payment Agreement Request</a> on page 1728
Payment Agreement Request screen	<a href="#">Payment Agreement Request (Used for Searching)</a> on page 1728

## Defining Characteristics for a Payment Agreement Request

### Prerequisites

To define characteristics for a payment agreement request:

- Characteristic types defined in the application (where the characteristic entity is set to **Payment Agreement Request**)

### Procedure

To define characteristics for a Payment Agreement Request:

1. Ensure that the **Characteristics** section is expanded when you are editing, submitting, approving, rejecting or resubmitting a payment agreement.

The **Characteristics** section contains the following fields:

Field Name	Field Description	Mandatory (Yes or No)
Effective Date	Used to indicate the date from when the characteristic is effective for the payment agreement request.	Yes (Conditional)

**Note:** This field is required when you are defining a characteristic for the payment agreement request.

Field Name	Field Description	Mandatory (Yes or No)
Characteristic Type	Used to indicate the characteristic type.  <b>Note:</b> The list includes only those characteristic types where the characteristic entity is set to Payment Agreement Request.	Yes (Conditional)  <b>Note:</b> This field is required when you are defining a characteristic for the payment agreement request.
Characteristic Value	Used to specify the value for the characteristic type.  <b>Note:</b> On specifying the value for a predefined characteristic type, the description of the characteristic value appears corresponding to the <b>Characteristic Value</b> field.	Yes (Conditional)  <b>Note:</b> This field is required when you are defining a characteristic for the payment agreement request.

2. Enter the required details.

**Note:** If you select a predefined characteristic type, the **Search** () icon appears corresponding to the **Characteristic Value** field. On clicking the **Search** icon, you can search for a predefined characteristic value.

3. If you want to define more than one characteristic for the payment agreement request, click the **Add** () icon and then repeat step 2.

**Note:** However, if you want to remove a characteristic from the payment agreement request, click the **Delete** () icon corresponding to the characteristic.

### Related Topics

For more information on...	See...
How to create a payment agreement request	<a href="#">Creating a Payment Agreement Request</a> on page 1732
How to edit a payment agreement request	<a href="#">Editing a Payment Agreement Request</a> on page 1742

## Defining Payment Schedule for a Payment Agreement Request

### Prerequisites

To define payment schedule for a payment agreement request:

- Scheduled date, sum of installments for overdue or unpaid bills defined in the application for which the payment is scheduled is set to **Payment Agreement Request**

### Procedure

To define payment schedule for a Payment Agreement Request:

1. Ensure that the **Payment Schedule** section is expanded when you are editing, submitting, approving, rejecting or resubmitting a payment agreement.

The **Payment Schedule** section contains the following fields:

Field Name	Field Description	Mandatory (Yes or No)
Schedule Date	Used to indicate the date schedule for the payment.	Yes (Conditional) <b>Note:</b> This field is required when you are defining a payment schedule for the payment agreement request.
Schedule Amount	Used to indicate the amount scheduled for overdue or unpaid bills to be paid in installments. <b>Note:</b> This field appears only when you select a <b>Schedule Date</b> for the payment schedule.	Yes (Conditional) <b>Note:</b> This field is required only when you select a <b>Schedule Date</b> for the payment schedule.
Auto Pay ID	Used to indicate the auto pay id of the payor. <b>Note:</b> This field appears only when you select auto pay method option for <b>Pay Method</b> . The <b>Search</b>  icon appears corresponding to this field. On clicking the <b>Search</b> icon, the <b>Auto Pay ID Search</b> window appears.	No

- Enter the required details.

**Note:** If you select a auto pay method option for **Pay Method**, the **Search**  icon appears corresponding to the **Auto Pay ID** field. On clicking the **Search** icon, you can search for a **Payor Account ID**.

- If you want to define more than one payment schedule for the payment agreement request, click the **Add**  icon and then repeat step 2.

**Note:** However, if you want to remove a payment schedule from the payment agreement request, click the **Delete**  icon corresponding to the payment schedule.

### Related Topics

For more information on...	See...
How to create a payment agreement request	<a href="#">Creating a Payment Agreement Request</a> on page 1732
How to edit a payment agreement request	<a href="#">Editing a Payment Agreement Request</a> on page 1742

## Viewing the Bills Added in the Payment Agreement Request

### Procedure

To view the bills added in the payment agreement request:

- Search for the payment agreement request in the **Payment Agreement Request** screen.

- In the **Search Results** section, click the **Broadcast**  icon corresponding to the payment agreement request whose bill details you want to view.

The **Bill Details** zone appears.

**Note:** Bill are added in **Search Bills** zone on the **Bills** tab.

### Related Topics

For more information on...	See...
How to create a payment agreement request	<a href="#">Creating a Payment Agreement Request</a> on page 1732

## Viewing the Payment Agreement Request Details

### Procedure

To view the details of a payment agreement request:

- Search for the payment agreement request in the **Payment Agreement Request** screen.
- In the **Search Results** section, click the link in the **Payment Agreement Request Information** column corresponding to the payment agreement request whose details you want to view.

The **Payment Agreement Request** screen appears. It consists of the following tabs:

- **Main** – This tab contains the following three zones:
    - **Payment Agreement Request** – Displays the details of the payment agreement request.
    - **Bill Details** – Lists the unpaid bill details of the payment agreement request.
    - **Payment Schedule** – Lists the payment scheduled for unpaid bill amount of the payment agreement request.
  - **Log** – This tab lists the complete trail of actions performed on the payment request.
- View the details of the payment agreement request in the **Payment Agreement Request** zone.
  - View the bill details of the unpaid amount bills of payment agreement request in the **Bill Details** zone.
  - View the payment schedule details of payment agreement request in the **Payment Schedule** zone.

### Related Topics

For more information on...	See...
How to search for a payment agreement request	<a href="#">Searching for a Payment Agreement Request</a> on page 1732
<b>Payment Agreement Request</b> screen	<a href="#">Payment Agreement Request (Used for Viewing)</a> on page 1736
<b>Payment Agreement Request</b> zone	<a href="#">Payment Agreement Request</a> on page 1737
<b>Bill Details</b> zone	<a href="#">Bill Details</a> on page 1739
<b>Payment Schedule</b> zone	<a href="#">Payment Schedule</a> on page 1740

## Payment Agreement Request (Used for Viewing)

Once you create a payment agreement request type, the **Payment Agreement Request** screen allows you to:

- Edit the details of a payment agreement request along with bill details and payment schedule



- Delete a payment agreement request
- View the details of a payment agreement request
- View the bills added in a payment agreement request
- Define a payment schedule in a payment agreement request
- Submit a payment agreement request for approval
- Approve or reject a payment agreement request
- Resubmit a payment agreement request
- Filter an overdue bills of an account
- Add an overdue bill in a payment agreement request
- View the log of a payment agreement request
- Add a log entry for a payment agreement request

This screen consists of the following tabs:

- **Main** – This tab contains the following three zones:
  - **Payment Agreement Request** – Displays the details of the payment agreement request.
  - **Bill Details** – Lists the bill details of the payment agreement request.
  - **Payment Schedule** – Lists the payment schedule details of the bills for the payment agreement request.
- **Bills** – This tab lists the unpaid bill amount details for the same account.

**Note:** This tab will be displayed only when the payment agreement is in **Draft** status.

- **Log** – This tab lists the complete trail of actions performed on the payment agreement request.

## Payment Agreement Request - Main

The **Main** tab on the **Payment Agreement Request** contains the following zones:

- [Payment Agreement Request](#) on page 1737
- [Bill Details](#) on page 1739
- [Payment Schedule](#) on page 1740

## Payment Agreement Request

The **Payment Agreement Request** zone displays the details of the payment agreement request. This zone contains the following sections:

- **Main** – This section provides basic information about the payment agreement request. It contains the following fields:

Field Name	Field Description
Payment Agreement Request Information	Displays information about the payment agreement request.
Payment Agreement Request Type	Indicates the payment agreement request type using which the payment agreement request is created.  <b>Note:</b> It has a link. On clicking the link, the <b>Payment Agreement Request Type</b> screen appears where you can view the details of the payment agreement request type.

Field Name	Field Description
Account Information	<p>Displays information about the account for which the payment agreement request is created. In addition, a context menu appears corresponding to this field which helps in navigating to other screens in the application.</p> <p><b>Note:</b> It has a link. On clicking the link, the <b>Account</b> screen appears where you can view the details of the respective account.</p>
Status	<p>Indicates the status of the payment agreement request. The valid values are:</p> <ul style="list-style-type: none"> <li>• Active</li> <li>• Draft</li> <li>• Approval In Progress</li> <li>• Broken Promise</li> <li>• Kept Promise</li> <li>• Rejected</li> </ul>
Payor Account ID	<p>Displays the payment agreement requests which are created for a particular payor account. In addition, a context menu appears corresponding to this field which helps in navigating to other screens in the application.</p> <p><b>Note:</b> It has a link. On clicking the link, the <b>Account</b> screen appears where you can view the details of the respective account.</p>
Pay Method	Displays the method of payment of amount.
Total Unpaid Amount	Displays the unpaid amount for selected bills.
Total Future Schedule Amount	Displays the total schedule amount.

- **Characteristics** – This section lists the characteristics defined for the payment of selected bills. It contains the following columns:

Column Name	Column Description
Effective Date	Displays the date from when the characteristic is effective for the payment agreement request.
Characteristic Type	Indicates the characteristic type.
Characteristic Value	Displays the value of the characteristic type.

- **Record Actions** – This section contains the following buttons:

Column Name	Column Description
Edit	<p>Used to edit the details of the payment agreement request.</p> <p><b>Note:</b> The <b>Edit</b> button appears only when the payment agreement request is in the <b>Active</b> or <b>Draft</b> status.</p>
Delete	<p>Used to delete the payment agreement request.</p> <p><b>Note:</b> The <b>Delete</b> button appears only when the payment agreement request is in the <b>Draft</b> status.</p>

Column Name	Column Description
Submit	Used to submit the payment agreement request for approval.  <b>Note:</b> The <b>Submit</b> button appears only when the payment agreement request is in the <b>Draft</b> status.
Approve	Used to approve the payment agreement request.  <b>Note:</b> The <b>Approve</b> button appears only when: <ul style="list-style-type: none"> <li>• The payment agreement request is in the <b>Approval In Progress</b> status.</li> <li>• A user with the approval To Do role is reviewing the payment agreement request.</li> </ul>
Reject	Used to reject the payment agreement request.  <b>Note:</b> The <b>Reject</b> button appears only when: <ul style="list-style-type: none"> <li>• The payment agreement request is in the <b>Approval In Progress</b> status.</li> <li>• A user with the approval To Do role is reviewing the payment agreement request.</li> </ul>
Resubmit	Used to change the status of the payment agreement request to <b>Draft</b> .  <b>Note:</b> The <b>Resubmit</b> button appears only when: <ul style="list-style-type: none"> <li>• The payment agreement request is in the <b>Approval In Progress</b> status.</li> <li>• A user with the approval To Do role is reviewing the payment agreement request.</li> </ul>

- **Record Information** – This section contains the following fields:

Field Name	Field Description
Business Object	Indicates the business object using which the payment agreement request is created. In addition, a context menu appears corresponding to this field which helps in navigating to other screens in the application.  <b>Note:</b> It has a link. On clicking the link, the <b>Business Object</b> screen appears where you can view the details of the respective business object.
Status Date/Time	Displays the date and time when the payment agreement request status is updated.
Create Date/Time	Displays the date and time when the payment agreement request is created.

### Bill Details

The **Bill Details** zone displays the bill details of the payment agreement request. This zone contains the following columns:

Column Name	Column Description
Bill Information	Displays additional information about the bill. In addition, this column has a context menu which helps in navigating to other screens in the application.  <b>Note:</b> It has a link. On clicking the link, the <b>Bill</b> screen appears with the details of the respective bill.
Bill Amount	Displays the bill amount when the bill was generated.
Due Date	Displays the due date of the bill.
Unpaid Amount	Displays the amount which is eligible for payment against the bill.
Overdue Process Information	Displays the overdue process information about the bill.  <b>Note:</b> It has a link. On clicking the link, the <b>Overdue Process</b> screen appears with details of the overdue process of the bill.

This zone contains the **Delete** button. This button appears when the payment agreement request is in the **Draft** status. It is used to delete bills of payment agreement request.

**Note:** One payment agreement request will have complete status debit bills of only one account. All bills under one payment agreement will be of same currency. Once payment agreement request is active, bills added under the request cannot be deleted.

**Note:** Pagination is used to display limited number of records in the **Search Results** section. You can use the navigation links, such as **Previous** and **Next** to navigate between pages.

### Payment Schedule

The **Payment Schedule** zone displays the payments scheduled for the bills of the payment agreement request. This zone contains the following columns:

Column Name	Column Description
Schedule Date	Displays the schedule date for payment of bills amount in installments.
Schedule Amount	Displays the scheduled amount for bills payment in installments.
Auto Pay ID	Displays the automatic payment ID.

**Note:** Pagination is used to display limited number of records in the **Search Results** section. You can use the navigation links, such as **Previous** and **Next** to navigate between pages.

## Payment Agreement Request - Bills

The **Bills** tab on the **Payment Agreement Request** contains the following zone:

- [Search Bills](#) on page 1740

**Note:** This tab is appears when the payment agreement request is in the **Draft** status.

### Search Bills

The **Search Bills** zone allows you to search for all overdue bills for the account of a payment agreement request using various search criteria. This zone contains the following two sections:

- **Search Criteria** – The **Search Criteria** section contains the following fields:

Field Name	Field Description	Mandatory (Yes or No)
Search By	Used to indicate whether you want to search for a payment agreement request using bill details.  <b>Note:</b> By default, the <b>Bill Details</b> option is selected.	Yes
Bill ID	Used to search for a particular bill.  <b>Note:</b> The <b>Search</b>  icon appears corresponding to this field. On clicking the <b>Search</b> icon, the <b>Bill Search</b> window appears.	No
Bill Date From	Used to search bills which are created from a particular date onwards.	No
To	Used to search bills which are created till a particular date.	No

**Note:** You must specify at least one search criterion while searching for the bill details.

- **Search Results** – On clicking the **Search** button, the search results appear based on the specified search criteria. The **Search Results** section contains the following columns:

Column Name	Column Description
Bill ID	Displays the bill ID.
Bill Information	Displays additional information about the bill. In addition, this column has a context menu which helps in navigating to other screens in the application.  <b>Note:</b> It has a link. On clicking the link, the <b>Bill</b> screen appears with the details of the respective bill.
Unpaid Amount	Displays the amount which is eligible for payment agreement request against the bill.
Overdue Process Information	Displays the overdue process information for the bill.

This zone contains the **Add** button. It is used to add bill details of payment agreement request.

**Note:** Pagination is used to display limited number of records in the **Search Results** section. You can use the navigation links, such as **Previous** and **Next** to navigate between pages.

**Note:** One payment agreement request will have complete status debit bills of only one account. All bills under one payment agreement will be of same currency. Bills which are part of another payment agreement request and which is not in completed status will not be available for selection.

### **Related Topics**

For more information on...	See...
How to search for a payment agreement request	<a href="#">Searching for a Payment Agreement Request</a> on page 1732
How to create a payment agreement request	<a href="#">Creating a Payment Agreement Request</a> on page 1732

For more information on...	See...
How to view the details of a payment agreement request	<a href="#">Viewing the Payment Agreement Request Details</a> on page 1736

## Payment Agreement Request - Log

The **Log** tab on the **Payment Agreement Request** screen contains the following zone:

- [Payment Agreement Request Log](#) on page 1742

### Payment Agreement Request Log

The **Payment Agreement Request Log** zone on the **Payment Agreement Request** screen lists the complete trail of actions performed on the payment agreement request. This zone contains the following columns:

Column Name	Column Description
Date/Time	Displays the date and time when the action was performed on the payment agreement request.
Details	Displays the details about the action performed on the payment agreement request.
User	Indicates the user who has performed the action on the payment agreement request.
Log Type	Indicates the type of log.
Related Object	Indicates the object or entity which is generated when the action is performed on the payment agreement request.
Status Reason	Displays the status reason of action performed on the payment agreement request.
Old Payment Schedule	Displays the details of old payment schedule.

**Note:** You can manually add a log entry for the payment agreement request by clicking the **Add Log Entry** link in the upper right corner of the **Payment Agreement Request Log** zone.

The **Add Payment Agreement Request Log** window appears. Enter **Log Details** and click **Save**. The payment agreement request log is added.

### Related Topics

For more information on...	See...
How to view the log of a payment agreement request	<a href="#">Viewing the Log of a Payment Agreement Request</a> on page 1753
How to add the log for a payment agreement request	<a href="#">Adding a Log Entry for a Payment Agreement Request</a> on page 1754

## Editing a Payment Agreement Request

### Procedure

To edit a payment agreement request:

1. Search for the payment agreement request in the **Payment Agreement Request** screen.
2. In the **Search Results** section, click the link in the **Payment Agreement Request Information** column corresponding to the payment agreement request whose details you want to edit.

The **Payment Agreement Request** screen appears.

- Click the **Edit** button in the **Payment Agreement Request** zone.

**Note:** The **Edit** button appears only when the payment agreement request is in the **Active** or **Draft** status.

The **Payment Agreement Request** screen appears. It contains the following sections:

- Main** – Used to specify basic details about the payment agreement request. This section contains the following fields:

Field Name	Field Description	Mandatory (Yes or No)
Payment Agreement Request Information	Displays information about the payment agreement request.	Not applicable
Payment Agreement Request Type	Indicates the payment agreement request type using which the payment agreement request is created.	Not applicable
Account Information	Used to indicate the account for which you want to create the payment agreement request.	Yes
Third Party Payor	Used to specify the third party payor. <b>Note:</b> The values appears for selection only if the third party payor check box is selected.	No
Payor Account ID	Displays the account ID of selected <b>Third Party Payor</b> .	Not applicable
Pay Method	Used to indicate the payment method. <b>Note:</b> The valid values differ with respect to the description added for respective pay method in the <b>Pay Method</b> screen.	Yes
Comments	Used to specify additional details about the payment agreement request.	No
Total Unpaid Amount	Displays the sum of unpaid amount of the bills.	Not applicable
Total Future Schedule Amount	Displays the sum of future schedule amount.	Not applicable

- Bill Details** – Used to specify the bill details in the payment agreement request. This section contains the following column:

Column Name	Column Description	Mandatory (Yes or No)
Bill ID	Used to search a particular bill. <b>Note:</b> The <b>Search</b>  icon appears corresponding to the field. On clicking the <b>Search</b> icon, the <b>Bill Search</b> window appears. Bill details are displayed corresponding to the searched bill id.	Yes

If you want to define more than one bill details for the payment agreement request, click the **Add** (+) icon.

**Note:** However, if you want to remove a bill detail from the payment agreement request, click the **Delete** (🗑️) icon corresponding to the bill ID.

- **Payment Schedule** – Used to specify the payment schedule details in the payment agreement request. This screen contains the following columns:

Column Name	Column Description	Mandatory (Yes or No)
Schedule Date	Used to specify the schedule date for payment of schedule amount in the form of installments.	Yes
Schedule Amount	Used to specify the schedule amount to be paid in terms of installments.	Yes
Auto Pay ID	Used to search for auto pay ID.  <b>Note:</b> This field can be edited only when the <b>Pay Method</b> is selected for electronic payment of schedule amount. The <b>Search</b> (🔍) icon appears corresponding to the field. Auto pay details are displayed corresponding to the searched auto pay id.	Yes (Conditional)  <b>Note:</b> This field is required when you are defining an electronic payment for <b>Pay Method</b> .

If you want to define more than one payment schedules for the payment agreement request, click the **Add** (+) icon.

**Note:** However, if you want to remove a payment schedule from the payment agreement request, click the **Delete** (🗑️) icon corresponding to the schedule date.

- **Characteristics** – Used to define characteristics for the payment tender. This section contains the following fields:

Field Name	Field Description	Mandatory (Yes or No)
Effective Date	Used to specify the date from when the characteristic is effective for the payment agreement request.	Yes (Conditional)  <b>Note:</b> This field is required when you are defining a characteristic for the payment agreement request.
Characteristic Type	Used to indicate the characteristic type.  <b>Note:</b> The list includes only those characteristic types where the characteristic entity is set to <b>Payment Agreement Request</b> .	Yes (Conditional)  <b>Note:</b> This field is required when you are defining a characteristic for the payment agreement request.



Field Name	Field Description	Mandatory (Yes or No)
Characteristic Value	Used to specify the value for the characteristic type.  <b>Note:</b> On specifying the value for a predefined characteristic type, the description of the characteristic value appears corresponding to the <b>Characteristic Value</b> field.	Yes (Conditional)  <b>Note:</b> This field is required when you are defining a characteristic for the payment agreement request.

4. Add or modify the details of the payment agreement request, if required.
5. Define, edit, or remove characteristics from the payment agreement request, if required.
6. Click **Save**.

The changes made to the payment agreement request are saved.

**Note:** Approval is not required for modifications done on an active payment agreement request.

### **Related Topics**

For more information on...	See...
How to search for a payment agreement request	<a href="#">Searching for a Payment Agreement Request</a> on page 1732
<b>Payment Agreement Request</b> screen	<a href="#">Payment Agreement Request (Used for Viewing)</a> on page 1736
<b>Payment Agreement Request</b> zone	<a href="#">Payment Agreement Request</a> on page 1737
How to define characteristics for a payment agreement request	<a href="#">Defining Characteristics for a Payment Agreement Request</a> on page 1733

## Deleting a Payment Agreement Request

### **Procedure**

To delete a payment agreement request:

1. Search for the payment agreement request in the **Payment Agreement Request** screen.
2. In the **Search Results** section, click the link in the **Payment Agreement Request Information** column corresponding to the payment request that you want to delete.

The **Payment Agreement Request** screen appears.

3. Click the **Delete** button in the **Payment Agreement Request** zone.

A message appears confirming whether you want to delete the payment agreement request.

**Note:** The **Delete** button appears only when the payment agreement request is in the **Draft** status.

4. Click **OK**.

The payment agreement request is deleted.

### **Related Topics**

For more information on...	See...
How to search for a payment agreement request	<a href="#">Searching for a Payment Agreement Request</a> on page 1732
<b>Payment Agreement Request</b> screen	<a href="#">Payment Agreement Request (Used for Viewing)</a> on page 1736
<b>Payment Agreement Request</b> zone	<a href="#">Payment Agreement Request</a> on page 1737
<b>Bill Details</b> zone	<a href="#">Bill Details</a> on page 1739
<b>Payment Schedule</b> zone	<a href="#">Payment Schedule</a> on page 1740

## Submitting a Payment Agreement Request

### Prerequisites

To submit a payment agreement request, you should have:

- Payment Agreement Request Types defined in the request.

### Procedure

To submit a payment agreement request:

1. Search for the payment agreement request in the **Payment Agreement Request** screen.
2. In the **Search Results** section, click the link in the **Payment Agreement Request Information** column corresponding to the payment agreement request that you want to submit.

The **Payment Agreement Request** screen appears.

3. Click the **Submit** button in the **Payment Agreement Request** zone.

The system behaves in the following manner:

If...	Then
The <b>Approval Required</b> check box is selected in the payment agreement request type using which the payment agreement request is created.	A To Do of the <b>To Do Type</b> is created for the payment agreement request entity and sent to the approver. Status of the payment agreement request is changed to <b>Approval In Progress</b> . <b>C1-PAREQ</b> is the to do type for Payment Agreement Request.
The <b>Approval Required</b> check box is not selected in the payment agreement request type using which the payment agreement request is created.	The payment agreement request is created using the specified payment agreement request types and the status of the payment agreement request is changed to as specified in the payment agreement request type.

### **Note:**

The **Submit** button appears only when the payment agreement request is in the **Draft** status.

For more information about the **Payment Agreement Request Periodic Monitor (C1-PAREQ)** batch, refer to Oracle Revenue Management and Billing Batch Guide.

### Related Topics

For more information on...	See...
How to search for a payment agreement request	<a href="#">Searching for a Payment Agreement Request</a> on page 1732
<b>Payment Agreement Request</b> screen	<a href="#">Payment Agreement Request (Used for Viewing)</a> on page 1736

For more information on...	See...
Payment Agreement Request zone	<a href="#">Payment Agreement Request</a> on page 1737

## Removing an Overdue Bill from a Payment Agreement Request

### Prerequisites

To remove an overdue bill from a payment agreement request, you should have:

- Bill details should be available to be removed from payment agreement request

### Procedure

To delete a bill detail from payment agreement request:

1. Search for the payment agreement request in the **Payment Agreement Request** screen which is in **Draft** status.
2. In the **Search Results** section, click the link in the **Payment Agreement Request Information** column corresponding to the payment agreement request whose details you want to view.

By default, the **Main** tab of the **Payment Agreement Request** screen appears.

3. List of bill details are displayed in the **Bill Details** zone.
4. Select the check box corresponding to the bill which you want to delete from the payment agreement request.

You can delete more than one bill from the payment agreement request at the same time.

5. Click **Delete**.

A message appears indicating that selected bills have been successfully deleted from the payment agreement request.

6. Click **OK**.

Note that the bill is added in the **Search Bills** zone in the **Bills** tab.

**Note:** Bills in **Active** status cannot be deleted.

### Related Topics

For more information on...	See...
How to search for a payment agreement request	<a href="#">Searching for a Payment Agreement Request</a> on page 1732
How to create a payment agreement request	<a href="#">Creating a Payment Agreement Request</a> on page 1732
<b>Bill Details</b> zone	<a href="#">Bill Details</a> on page 1739
<b>Search Bills</b> zone	<a href="#">Search Bills</a> on page 1740

## Approving a Payment Agreement Request

You can view the number of payment agreement requests which are pending for approval in the **Payment Agreement Request** screen. The approver can review, and accordingly approve or reject the payment agreement request based on the observations.

**Note:** The system will not allow you to approve or reject a payment agreement request submitted by you.

### Procedure

To approve a payment agreement request:

1. Do either of the following:

If you want to	Then
Approve a payment agreement request through the <b>Payment Agreement Request</b> screen	<ol style="list-style-type: none"> <li>1. Search for the payment agreement request in the <b>Payment Agreement Request</b> screen.</li> <li>2. In the <b>Search Results</b> section, click the link in the <b>Payment Agreement Request Information</b> column corresponding to the payment agreement request which you want to review.</li> </ol>
Approve a payment agreement request from the <b>To Do List</b> screen	<ol style="list-style-type: none"> <li>1. Click the <b>Menu</b> link in the <b>Application</b> toolbar. A list appears.</li> <li>2. From the <b>Main</b> menu, select <b>To Do</b> and then click <b>To Do List</b>. The <b>To Do Type for User Search</b> window appears.</li> <li>3. Enter the to do type <b>C1-PAREQ</b> in the <b>To Do Type</b> field for the entity payment agreement request.</li> <li>4. Click the <b>Search</b> button corresponding to the <b>To Do Type</b> field. The <b>To Do List</b> screen appears.</li> <li>5. Select the <b>Open</b> option from the <b>Filter by</b> list to view all unassigned To Dos.</li> <li>6. Click the link in the <b>Message</b> column corresponding to the To Do of the payment agreement request that you want to review.</li> </ol>

The **Payment Agreement Request** screen appears.

2. Review the payment agreement request details.
3. Click the **Approve** button in the **Payment Agreement Request** zone.

The system behaves in the following manner:

If you are...	Then
Approving a payment agreement request	The status of the payment agreement request is changed to <b>Approval In Progress</b> as specified in the payment agreement request type.

**Note:** The **Approve** button appears only when:

- The payment agreement request is in the **Approval In Progress** status.
- A user with the approval To Do role is reviewing the payment agreement request.

### Related Topics

<b>For more information on...</b>	<b>See...</b>
<b>Payment Agreement Request</b> screen	<a href="#">Payment Agreement Request (Used for Viewing)</a> on page 1736
<b>Payment Agreement Request</b> zone	<a href="#">Payment Agreement Request</a> on page 1737
How to search for a payment agreement request	<a href="#">Searching for a Payment Agreement Request</a> on page 1732

## Rejecting a Payment Agreement Request

### Prerequisites

To reject a payment agreement request, you should have:

- Rejection reasons defined in the application

### **Note:**

While rejecting a payment agreement request, you need to specify the reason why you want to reject the payment agreement request. You can select the appropriate rejection reason only when you have defined the reasons for the **Rejected** status of the **C1-PaymentAgreementRequest** business object in the **Status Reason** screen.

The system will not allow you to approve or reject a payment agreement request submitted by you.

### Procedure

To reject a payment agreement request:

1. Do either of the following:

<b>If you want to</b>	<b>Then</b>
Reject a payment agreement request through the <b>Payment Agreement Request</b> screen	<ol style="list-style-type: none"> <li>1. Search for the payment agreement request in the <b>Payment Agreement Request</b> screen.</li> <li>2. In the <b>Search Results</b> section, click the link in the <b>Payment Agreement Request Information</b> column corresponding to the payment request which you want to review.</li> </ol>
Reject a payment agreement request from the <b>To Do List</b> screen	<ol style="list-style-type: none"> <li>1. Click the <b>Menu</b> link in the <b>Application</b> toolbar. A list appears.</li> <li>2. From the <b>Main</b> menu, select <b>To Do</b> and then click <b>To Do List</b>. The <b>To Do Type for User Search</b> window appears.</li> <li>3. Enter the to do type <b>C1-PAREQ</b> in the <b>To Do Type</b> field for the entity payment agreement request.</li> <li>4. Click the <b>Search</b> button corresponding to the <b>To Do Type</b> field. The <b>To Do List</b> screen appears.</li> <li>5. Select the <b>Open</b> option from the <b>Filter by</b> list to view all unassigned To Dos.</li> </ol>

If you want to	Then
	6. Click the link in the <b>Message</b> column corresponding to the To Do of the payment agreement request that you want to review.

The **Payment Agreement Request** screen appears.

- Review the payment agreement request details.
- Click the **Reject** button in the **Payment Agreement Request** zone.

The **Reject Payment Request** window appears. It contains following fields:

Field Name	Field Description	Mandatory (Yes or No)
Status Reason	Used to indicate the reason why you want to reject the payment agreement request.	Yes
Comments	Used to specify additional information while rejecting the payment agreement request.	No

**Note:** The **Reject** button appears only when:

- The payment agreement request is in the **Approval In Progress** status.
- A user with the approval To Do role is reviewing the payment agreement request.

- Select the rejection reason from the **Status Reason** list.
- Click **Save**.

The status of the payment agreement request is changed to **Rejected**.

### Related Topics

For more information on...	See...
How to search for a payment agreement request	<a href="#">Searching for a Payment Agreement Request</a> on page 1732
<b>Payment Agreement Request</b> screen	<a href="#">Payment Agreement Request (Used for Viewing)</a> on page 1736
<b>Payment Agreement Request</b> zone	<a href="#">Payment Agreement Request</a> on page 1737

## Resubmitting a Payment Agreement Request

### Prerequisites

To resubmit a payment agreement request, you should have:

- Entities added in the payment agreement request which is submitted for approval.

### Procedure

To resubmit a payment agreement request:

- Search for the payment agreement request in the **Payment Agreement Request** screen.
- In the **Search Results** section, click the link in the **Payment Agreement Request Information** column corresponding to the payment agreement request that you want to resubmit.

The **Payment Agreement Request** screen appears.

- Click the **Resubmit** button in the **Payment Agreement Request** zone.

The **Resubmit Payment Agreement Request** screen appears.

**Note:** The **Resubmit** button appears only when the payment agreement request is in the **Approval In Progress** status.

A To Do of the **C1-PAREQ** To Do type is created and sent to the request submitter using the submitter TO DO Role and the status of the payment agreement request is changed to **Draft**.

4. Enter the comments in the respective field and click **Save**.

**Note:** While resubmitting, To Do will be sent to the submitter of the request using the submitter To Do Role mapped on the payment agreement request type and the request will be moved to Draft status. The submitter can do necessary changes and re submit the request. Log will be maintained when the approver sends the request back to submitter.

### **Related Topics**

<b>For more information on...</b>	<b>See...</b>
How to search for a payment agreement request	<a href="#">Searching for a Payment Agreement Request</a> on page 1732
<b>Payment Agreement Request</b> screen	<a href="#">Payment Agreement Request (Used for Viewing)</a> on page 1736
<b>Payment Agreement Request</b> zone	<a href="#">Payment Agreement Request</a> on page 1737
How to submit a payment agreement request	<a href="#">Submitting a Payment Agreement Request</a> on page 1746

## **Filtering Overdue Bills of an Account**

The **Search Bills** zone lists bills that are overdue for an account. You will not find any records in this zone if the payment agreement request does not have overdue bills in the account. This zone contains the following fields as search criteria:

<b>Field Name</b>	<b>Field Description</b>	<b>Mandatory (Yes or No)</b>
Search By	Used to indicate whether you want to search for a payment agreement request using bill details. <b>Note:</b> By default, the <b>Bill Details</b> option is selected.	Yes
Bill ID	Used to search for a particular bill. <b>Note:</b> The <b>Search</b>  icon appears corresponding to the field. On clicking the <b>Search</b> icon, the <b>Bill Search</b> window appears.	No
Bill Date From	Used to search bills which are created from a particular date onwards.	No
To	Used to search bills which are created till a particular date.	No

By default, the **Search Bills** zone appears in the **Bills** tab of **Payment Agreement Request** screen. By default, the **Filter** area is visible. You can hide the **Filter** area by clicking the **Filters**  icon in the upper right corner of this zone.

By default, the search results section displays the following columns:

<b>Column Name</b>	<b>Column Description</b>
Bill ID	Displays the bill ID.

Column Name	Column Description
Bill Information	Displays additional information about the bill. In addition, this column has a context menu which helps in navigating to other screens in the application.  <b>Note:</b> It has a link. On clicking the link, the <b>Bill</b> screen appears with the details of the respective bill.
Unpaid Amount	Displays the amount which is eligible for payment agreement request against the bill.
Overdue Process Information	Displays the overdue process information for the bill.

### Related Topics

For more information on...	See...
<b>Bills</b> tab	<a href="#">Payment Agreement Request - Bills</a> on page 1740
<b>Bill Details</b> zone	<a href="#">Bill Details</a> on page 1739
How to add an overdue bill in a payment agreement request	<a href="#">Adding an Overdue Bill in a Payment Agreement Request</a> on page 1752

## Adding an Overdue Bill in a Payment Agreement Request

### Prerequisites

To add an overdue bill in a payment agreement request, you should have:

- Overdue bills should be available for accounts to add in payment agreement request

### Procedure

To add an overdue bill in a payment agreement request:

**Note:** A bill with outstanding amount greater than zero which is not part of an overdue process will be allowed to be added in a payment agreement request. While a bill with negative outstanding amount will not be allowed to be added in a payment agreement request.

1. Search for the payment agreement request in the **Payment Agreement Request** screen which is in **Draft** or **Active** status.
2. In the **Search Results** section, click the link in the **Payment Agreement Request Information** column corresponding to the payment agreement request whose details you want to view.  
  
The **Payment Agreement Request** screen appears.
3. Click the **Bills** tab.  
  
The **Bills** tab appears.
4. Enter the search criteria in the **Search Bills** zone.  
  
In the **Search Results** section, list of bills meeting the search criteria are displayed.
5. Select the check box corresponding to the bill which you want to add to the payment agreement request from the **Search Results** section.  
  
You can add more than one bill to the payment agreement request at the same time.
6. Click **Add**.  
  
A message appears indicating that selected bills have been successfully added to the payment agreement request.
7. Click **OK**.



Note that the bill is added in the **Bill Details** zone in the **Main** tab.

### Related Topics

For more information on...	See...
How to search for a payment agreement request	<a href="#">Searching for a Payment Agreement Request</a> on page 1732
How to create a payment agreement request	<a href="#">Creating a Payment Agreement Request</a> on page 1732
<b>Search Bills</b> zone	<a href="#">Search Bills</a> on page 1740
<b>Bill Details</b> zone	<a href="#">Bill Details</a> on page 1739

## Viewing the Log of a Payment Agreement Request

### Procedure

To view the log of a payment agreement request:

1. Search for the payment agreement request in the **Payment Agreement Request** screen.
2. In the **Search Results** section, click the link in the **Payment Agreement Request Information** column corresponding to the payment agreement request whose log you want to view.

The **Payment Agreement Request** screen appears. It consists of the following tabs:

- **Main** – This tab contains the following three zones:
  - **Payment Agreement Request** – Displays the details of the payment agreement request.
  - **Bill Details** – Lists the bill details of the payment agreement request.
  - **Payment Schedule** – Lists the payment schedule details of the bills for the payment agreement request.
- **Bills** – This tab lists the unpaid bill amount details for the same account.

**Note:** This tab will be displayed only when the payment agreement is in **Draft** status.

- **Log** – This tab lists the complete trail of actions performed on the payment agreement request.
3. Click the **Log** tab.

The **Payment Agreement Request Log** zone in the **Log** tab contains the following columns:

Column Name	Column Description
Date/Time	Displays the date and time when the action was performed on the payment agreement request.
Details	Displays the details about the action performed on the payment agreement request.
User	Indicates the user who has performed the action on the payment agreement request.
Log Type	Indicates the type of log.
Related Object	Indicates the object or entity which is generated when the action is performed on the payment agreement request.
Status Reason	Indicates the reason why the payment agreement request was rejected.
Old Payment Schedule	Displays the details of old payment schedule.

**Note:** You can manually add a log entry for the payment agreement request by clicking the **Add Log Entry** link in the upper right corner of the **Payment Agreement Request Log** zone.

### Related Topics

For more information on...	See...
How to search for a payment agreement request	<a href="#">Searching for a Payment Agreement Request</a> on page 1732
How to add a log entry for a payment agreement request	<a href="#">Adding a Log Entry for a Payment Agreement Request</a> on page 1754

## Adding a Log Entry for a Payment Agreement Request

### Procedure

To add a log entry for a payment agreement request:

1. Search for the payment agreement request in the **Payment Agreement Request** screen.
2. In the **Search Results** section, click the link in the **Payment Agreement Request Information** column corresponding to the payment agreement request whose log you want to edit.

The **Payment Agreement Request** screen appears. It consists of the following tabs:

- **Main** – This tab contains the following three zones:
  - **Payment Agreement Request** – Displays the details of the payment agreement request.
  - **Bill Details** – Lists the bill details of the payment agreement request.
  - **Payment Schedule** – Lists the payment schedule details of the bills for the payment agreement request.
- **Bills** – This tab lists the unpaid bill amount details for the same account.

**Note:** This tab will be displayed only when the payment agreement is in **Draft** status.

- **Log** – This tab lists the complete trail of actions performed on the payment agreement request.
3. Click the **Log** tab.

The **Log** tab appears.

4. Click the **Add Log Entry** link in the upper right corner of the **Payment Agreement Request Log** zone.

The **Add Payment Agreement Request Log** window appears. It contains the following fields:

Field Name	Field Description	Mandatory (Yes or No)
Payment Agreement Request Information	Displays information about the payment agreement request.	Not applicable
Log Details	Used to specify additional comments on the payment agreement request.	Yes

5. Enter the comments in the **Log Details** field.
6. Click **Save**.

The log entry is added in the **Payment Agreement Request Log** zone.

### Related Topics

For more information on...	See...
How to search for a payment agreement request	<a href="#">Searching for a Payment Agreement Request</a> on page 1732



---

# Chapter 27

---

## Inbound Message

---

### Topics:

- [Customer Inbound Message](#)
- [Membership Inbound Message](#)
- [ASO Customer Inbound Message](#)
- [Health Care Inbound Message](#)
- [Inbound Message Type](#)
- [Inbound Message \(Used for Searching\)](#)
- [Inbound Message \(Used for Viewing\)](#)

Oracle Revenue Management and Billing enables you to create the following inbound messages through the respective inbound web services:

Inbound Message	Inbound Web Service
<a href="#">Customer Inbound Message</a> on page 1758	<a href="#">CI-CustomerStructureInboundMessage</a> on page 2006
<a href="#">Membership Inbound Message</a> on page 1796	<a href="#">CI-MembershipInboundMessage</a> on page 2007
<a href="#">ASO Customer Inbound Message</a> on page 1826	<a href="#">CI-ASOCustomerInboundMessage</a> on page 2007
<a href="#">Health Care Inbound Message</a> on page 1863	<a href="#">CI-HCInboundMessage</a> on page 2008

Once an inbound message is created, you can submit the inbound message for validation and processing from the user interface or through a batch process. The following table lists the batches which validate and process the respective inbound message at regular intervals:

Inbound Message	Batch Control Name
Customer Inbound Message	Customer Inbound Message Periodic Monitor (C1-CUSIN)
Membership Inbound Message	Membership Inbound Message Periodic Monitor (C1-MEMIN)
ASO Customer Inbound Message	Customer Inbound Message Periodic Monitor (C1-CUSIN)
Health Care Inbound Message	Health Care Inbound Message Periodic Monitor (C1-HCINB)

For more information about the batches, refer to *Oracle Revenue Management and Billing Batch Guide*.

## Customer Inbound Message

---

On calling the **C1-CustomerStructureInboundMessage** web service, a customer inbound message is created in the **Pending** status. When the **Customer Inbound Message Periodic Monitor (C1-CUSIN)** batch is invoked, the system checks whether there are any customer inbound messages in the **Pending** status. If there is a customer inbound message in the **Pending** status, the system validates the customer inbound message. If a customer inbound message is successfully validated, it is processed further and the following entities are created or updated in the system based on the available information:

- Person
- Account
- Contract
- Policy
- Policy Plan
- Packaged Savings
- Billable Charges (for packaged savings and/or non-eligibility based fees)

In addition, the system enables you to submit the customer inbound messages for validation and processing from the user interface. On submitting a customer inbound message, the system validates the customer inbound message. If a customer inbound message is successfully validated, it is processed further and the required entities are created or updated in the system based on the available information.

Once all required entities are created or updated in the system, the status of the customer inbound message is changed to **Processed**. If any error occurs while validating or processing a customer inbound message, the status of the customer inbound message is changed to **Rejected**. The system enables you to either reprocess or void a rejected customer inbound message. The system can reprocess a customer inbound message only when its status is changed to **Pending**. Using the **Retry** option, you can change the status of the customer inbound message from **Rejected** to **Pending**. The **Customer Inbound Message Periodic Monitor (C1-CUSIN)** batch will then reconsider the customer inbound message for validation and processing.

You can also configure the system such that the batch can automatically retry to process the rejected customer inbound messages. However, it will attempt to retry only when the **Maximum Retry** parameter in the **Retry for To Dos (C1-TODORETRY)** algorithm is set to a value greater than zero. Also, the maximum number of times the batch can attempt to retry and reprocess a customer inbound message depends on the value defined in the **Maximum Retry** parameter.

### Prerequisites

To use the customer inbound message feature, you need to do the following:

- Define the required customer inbound message types in the system.
- Define the required characteristic types where the characteristic entity is set to **Inbound Message Type**.
- Define the required characteristic types where the characteristic entity is set to **Inbound Message**.
- Define values for the required parameters in the **C1-CINMSGVAL**, **C1-CINMSGPRC**, **C1-TODORETRY**, and **C1-TDCRINMSG** algorithms.
- Define the **Policy Plan BO (C1PPLNBO)** characteristics for the policy type which is specified in the **C1-CINMSGPRC** algorithm.
- Define predefined values for the **C1PRBASE**, **C1PRSRSN**, **C1INVHLD**, **C1STISSE**, **C1PRTNRL**, **C1PRDCAT**, **C1RATCOV**, and **C1PSNINT** characteristic types.
- Define values for the **C1-SourceSystemLookup** extendable lookup.

- Define values for the **PER\_OR\_BUS\_FLG**, **ADDRESS\_TYPE\_FLG**, **EXT\_TYPE\_FLG**, **BILL\_ADDR\_SRCE\_FLG**, and **RATE\_COVRG\_CNTRACT\_TYPE** lookup fields.
- Define the required person identifier types, account identifier types, characteristic types, person relationship types, phone types, customer classes, bill cycles, divisions, bill route types, hold request types, service quantity identifiers, contract types, and policy person roles in the application.
- Define values for the **C1BC\_OPT\_TYP\_FLG** lookup field.

**Note:** You can then set the value for the option type (defined in the **C1BC\_OPT\_TYP\_FLG** lookup field) in the **C1-BILLCYCLE** feature configuration.

- Define values for the option types in the **C1-BILLCYCLE** feature configuration.
- Define values for the **C1\_INVOICE\_DAY\_BILL\_PERIOD\_FLG** lookup field.

**Note:** Each lookup field value should be mapped to a valid bill period which exists in the system. You must then define this lookup field value as a predefined value for the **C1OFFRST** characteristic type. The system will then use the bill period configured for the respective invoice day when the **C1OFFRST** characteristic is defined for the account.

- Define predefined values for the **C1OFFRST** characteristic type.
- Set the batch control type of the **Customer Inbound Message Periodic Monitor (C1-CUSIN)** batch to **Timed** and define the following attributes:
  - Time Interval
  - Timer Active
  - User ID
  - Batch Language
  - Email Address
- Define the required status reasons for the status to which a policy must be transitioned on policy termination and map each status reason to a prime source reason (which is a predefined value in the **C1PRSRSN** characteristic type).
- Define the required status reasons for the status to which a policy must be transitioned on policy reinstatement and map each status reason to a prime source reason (which is a predefined value in the **C1PRSRSN** characteristic type).
- Define bill cancel reasons which you want to use on packaged savings and premium bill segment cancelation during the policy or membership termination.

### **Related Topics**

<b>For more information on...</b>	<b>See...</b>
How to setup the <b>C1-BILLCYCLE</b> feature configuration	<a href="#">Setting the C1-BILLCYCLE Feature Configuration</a> on page 2905

## **Customer Inbound Message Status Transition through User Interface**

The following figure graphically indicates how a customer inbound message moves from one status to another when it is validated and processed through the user interface:

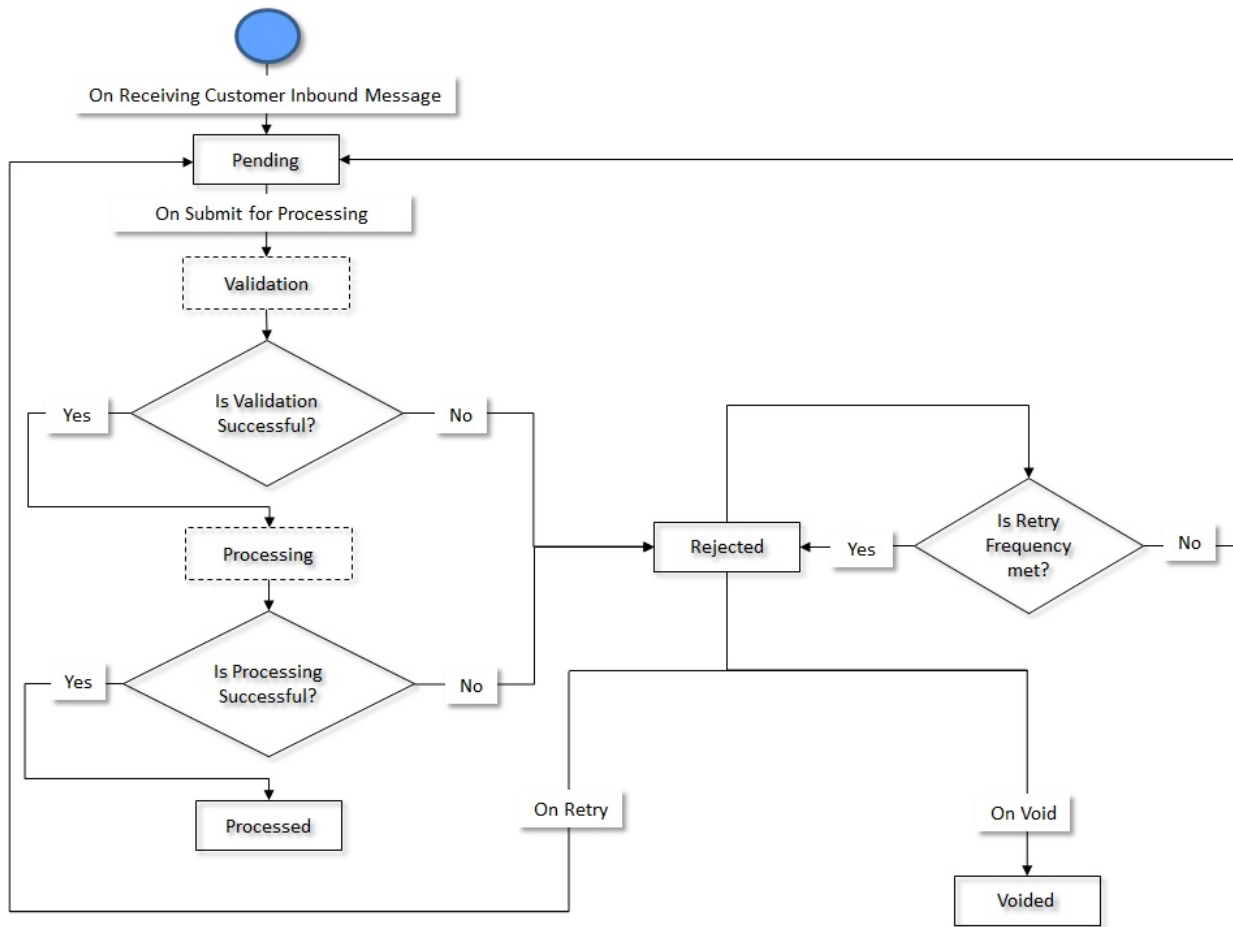

### Customer Inbound Message Status Transition through a Batch Process

The following figure graphically indicates how a customer inbound message moves from one status to another when it is validated and processed through the **Customer Inbound Message Periodic Monitor (C1-CUSIN)** batch:



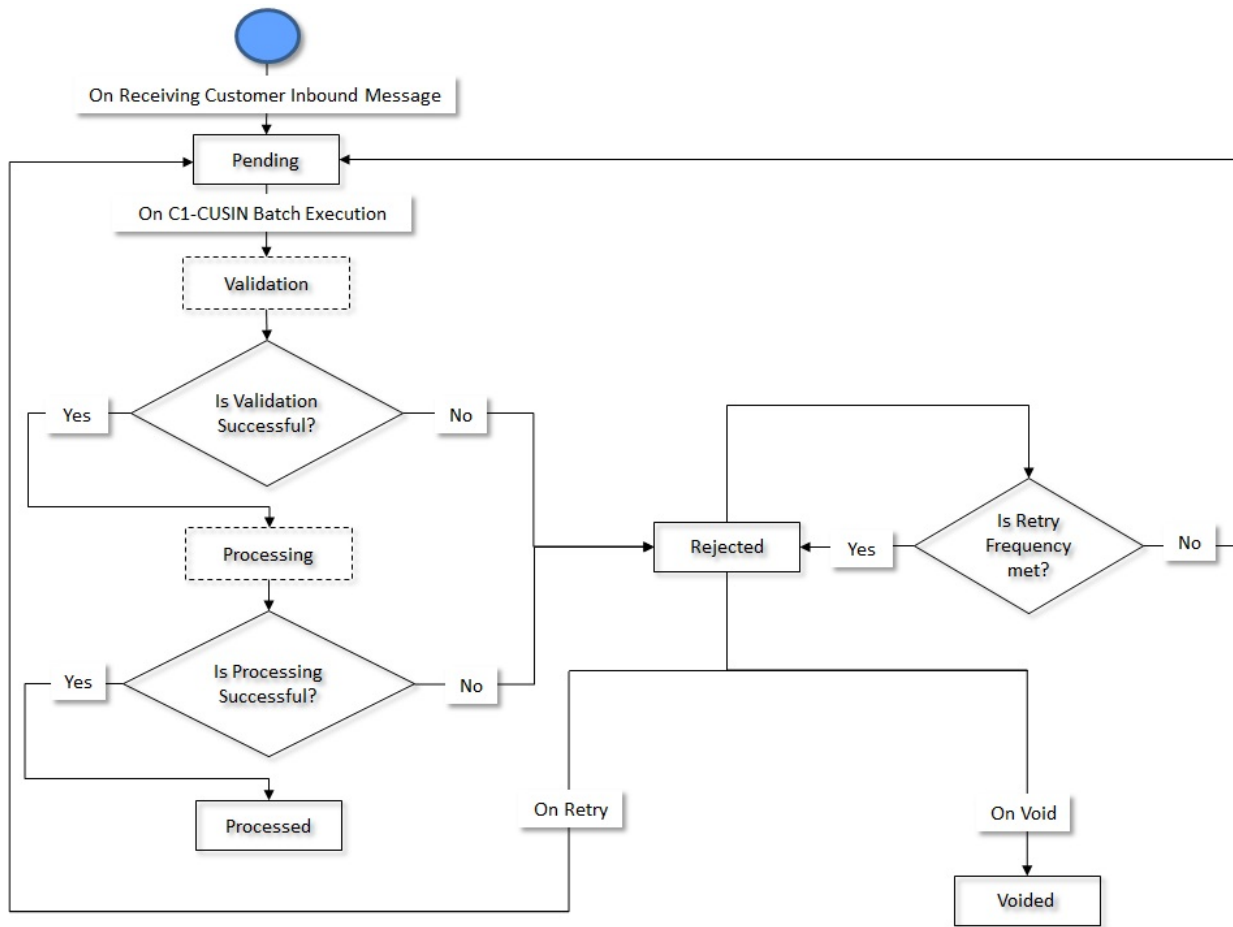

## Algorithms Used in C1-CustomerInboundMessage

The following table lists the algorithms which are used in the lifecycle of the **C1-CustomerInboundMessage** business object:

Status	System Event	Algorithm	Algorithm Type	Description
Pending	Monitor	C1-AT-RQJ	C1-GEN-BOMNJ	Refer to <a href="#">C1-AT-RQJ</a> on page 1762.
Validation	Monitor	F1-AT-RQJ	F1-GEN-BOMNJ	Refer to <a href="#">F1-AT-RQJ</a> on page 1257.
	Enter	C1-CINMSGVAL	C1-CINMSGVAL	Refer to <a href="#">C1-CINMSGVAL</a> on page 1762.
Processing	Monitor	F1-AT-RQJ	F1-GEN-BOMNJ	Refer to <a href="#">F1-AT-RQJ</a> on page 1257.
	Enter	C1-CINMSGPRC	C1-CINMSGPRC	Refer to <a href="#">C1-CINMSGPRC</a> on page 1763.
Rejected	Monitor	C1-TODORETRY	C1-TODORETRY	Refer to <a href="#">C1-TODORETRY</a> on page 1772.

Status	System Event	Algorithm	Algorithm Type	Description
	Enter	C1-TDCRINMSG	F1-TDCREATE	Refer to <a href="#">C1-TDCRINMSG</a> on page 1772.
Processed	-	-	-	-
Voided	-	-	-	-

### C1-AT-RQJ

This algorithm is invoked when the status of the customer or membership inbound message is changed to **Pending**. If the **isRetried** flag in the inbound message is set to **true**, it resets the flag to **false**.

It contains the following parameters:

- **Next Status** – Used when you want to override the default next status specified in the lifecycle.
- **Next Transition Condition** – Used when you want to override the default next transition condition specified in the lifecycle.

**Note:** At a time, you can specify value for either the **Next Status** or **Next Transition Condition** parameter. If you don't specify any value for these parameters, the system will transition the business object to the default next status specified in its lifecycle.

### F1-AT-RQJ

This algorithm transitions the current status of the business object to the specified status. It contains the following parameters:

- **Next Status** – Used when you want to override the default next status specified in the lifecycle.
- **Next Transition Condition** – Used when you want to override the default next transition condition specified in the lifecycle.

At a time, you can specify value for either the **Next Status** or **Next Transition Condition** parameter. If you don't specify any value for these parameters, the system will transition the business object to the default next status specified in its lifecycle.

### C1-CINMSGVAL

This algorithm is invoked when the **Customer Inbound Message Periodic Monitor (C1-CUSIN)** batch is executed and when you click the **Submit for Processing** button. It validates the customer inbound message which is in the **Pending** status. It checks the following:

- Whether the primary identifier is specified for the person.
- Whether the bill group information exist when the policy information is specified in the customer inbound message.
- Whether the bill cycle is specified in the bill group information.
- Whether the **Invoice Day** characteristic type (as mentioned in the **Invoice Day Characteristic Type** parameter) exists in the bill group information and a valid value is specified for this characteristic type.

If any of the above validation fails, the status of the customer inbound message is changed to **Rejected**. In addition, the appropriate log entry is added which you can view in the **Inbound Message Log** zone.

This algorithm contains the following parameters:

Parameter	Description	Mandatory (Yes or No)
Next Status	Used when you want to override the default next status specified in the lifecycle.	No
Next Transition Condition	Used when you want to override the default next transition condition specified in the lifecycle.	No
Invoice Day Characteristic Type	Used to specify the characteristic type which you want to use to store the invoice day for the account. This type of characteristic is defined on the account. The system then fetches the bill period mapped to the invoice day in the <b>C1_INVOICE_DAY_BILL_PERIOD_FLG</b> lookup field.  <b>Note:</b> By default, the parameter value is set to <b>C1OFFRST</b> . You can change the characteristic type, if required. However, you must specify a characteristic type where the characteristic entity is set to <b>Account</b> .	Yes

### C1-CINMSGPRC

This algorithm is invoked once a customer inbound message is successfully validated. It processes the customer inbound message and accordingly creates or updates a person, account, contract, policy, policy plan, packaged savings, and billable charges for packaged savings. If requested, it also terminates, reinstates, or renews a fully-insured policy.

If the processing fails due to any reason, the status of the customer inbound message is changed to **Rejected**. In addition, the appropriate log entry is added which you can view in the **Inbound Message Log** zone.

This algorithm contains the following parameters:

Parameter	Description	Mandatory (Yes or No)
Next Status	Used when you want to override the default next status specified in the lifecycle.	No
Next Transition Condition	Used when you want to override the default next transition condition specified in the lifecycle.  <b>Note:</b> By default, the parameter value is set to <b>F1OK</b> .	No
Hold Reason Characteristic Type	Used to specify the characteristic type which you want to use to store the reason why the account must be kept on hold. This type of characteristic is defined on the account.  <b>Note:</b> By default, the parameter value is set to <b>C1INVHLD</b> . You can change the characteristic type, if required. However, you must specify a characteristic type where the characteristic entity is set to <b>Account</b> .	Yes

Parameter	Description	Mandatory (Yes or No)
Franchise Person Relationship Type	<p>Used to specify the person relationship type. If the parent person's relationship type in the customer inbound message matches to this parameter value, the system will add the person's account and contract details in the parent person's statement construct.</p> <p><b>Note:</b> By default, the parameter value is set to <b>BILLING</b>. You can change the parameter value, if required. However, you must specify a person relationship type which is already defined in the system.</p>	No
Packaged Savings Contract Type	<p>Used to specify the contract type using which you want to create the packaged savings contract for accounts. This contract is then used to create packaged savings billable charges.</p> <p><b>Note:</b> By default, the parameter value is set to <b>PACKSAV</b>. You can change the parameter value, if required. However, you must specify a contract type which is already defined in the system.</p>	No
Policy Characteristic Type	<p>Used to specify the characteristic type which you want to use to store the policy ID. This type of characteristic is defined on the billable charge. The system then uses this characteristic to derive the packaged savings billable charge which you want to update.</p> <p><b>Note:</b> By default, the parameter value is set to <b>CIPOLICY</b>. You can change the characteristic type, if required. However, you must specify a characteristic type where the characteristic entity is set to <b>Billable Charge</b>.</p>	Yes
Policy Plan Characteristic Type	<p>Used to specify the characteristic type which you want to use to store the policy plan ID. This type of characteristic is defined on the contract. The system then uses this characteristic to derive the contract which you want to update.</p> <p><b>Note:</b> By default, the parameter value is set to <b>CIPOLPLN</b>. You can change the characteristic type, if required. However, you must specify a characteristic type where the characteristic entity is set to <b>Contract</b>.</p>	Yes

Parameter	Description	Mandatory (Yes or No)
Plan Code Characteristic Type	<p>Used to specify the characteristic type which you want to use to store the policy plan number. This type of characteristic is defined on the price item. The system then uses this characteristic to derive the price item which you want to update.</p> <p><b>Note:</b> By default, the parameter value is set to <b>C1HPLNID</b>. You can change the characteristic type, if required. However, you must specify a characteristic type where the characteristic entity is set to <b>Price Item</b>.</p>	Yes
Coverage Type Characteristic Type	<p>Used to specify the characteristic type which you want to use to store the coverage type. This type of characteristic is defined on the price item.</p> <p><b>Note:</b> By default, the parameter value is set to <b>C1PRDCAT</b>. You can change the characteristic type, if required. However, you must specify a characteristic type where the characteristic entity is set to <b>Price Item</b>.</p>	Yes
Rate Coverage Type Characteristic Type	<p>Used to specify the characteristic type which you want to use to store the rate coverage type. This type of characteristic is defined on the price item. The system then uses this characteristic to derive the price item which you want to update.</p> <p><b>Note:</b> By default, the parameter value is set to <b>C1RATCOV</b>. You can change the characteristic type, if required. However, you must specify a characteristic type where the characteristic entity is set to <b>Price Item</b>.</p>	Yes
Policy Person Role	<p>Used to specify the policy person role which you want to use while adding main customer in a policy.</p> <p><b>Note:</b> By default, the parameter value is set to <b>DEP</b>. You can change the parameter value, if required. However, you must specify a policy person role which is already defined in the system.</p>	No
Description on Bill	<p>Used to specify the description that you want to display on the packaged savings billable charge.</p> <p><b>Note:</b> By default, the parameter value is set to <b>Package Savings BC</b>.</p>	No

Parameter	Description	Mandatory (Yes or No)
Policy Start Date Characteristic Type	<p>Used to specify the characteristic type which you want to use to store the date from when the policy is effective. This type of characteristic is defined on the policy.</p> <p><b>Note:</b> By default, the parameter value is set to <b>C1PPSTDT</b>. You can change the characteristic type, if required. However, you must specify a characteristic type where the characteristic entity is set to <b>Policy</b>.</p>	Yes
Policy End Date Characteristic Type	<p>Used to specify the characteristic type which you want to use to store the date till when the policy is effective. This type of characteristic is defined on the policy. The system uses this characteristic while reinstating the policy.</p> <p><b>Note:</b> By default, the parameter value is set to <b>C1PPENDT</b>. You can change the characteristic type, if required. However, you must specify a characteristic type where the characteristic entity is set to <b>Policy</b>.</p>	Yes
Base Policy Indicator Characteristic Type	<p>Used to specify the characteristic type which you want to use to indicate whether the policy is a base policy. This type of characteristic is defined on the policy.</p> <p><b>Note:</b> By default, the parameter value is set to <b>C1PRBASE</b>. You can change the characteristic type, if required. However, you must specify a characteristic type where the characteristic entity is set to <b>Policy</b>.</p>	Yes
Invoice Day Characteristic Type	<p>Used to specify the characteristic type which you want to use to store the invoice day for the account. This type of characteristic is defined on the account. The system fetches the bill period mapped to the invoice day in the <b>C1_INVOICE_DAY_BILL_PERIOD_FLG</b> lookup field while creating packaged savings billable charges for accounts.</p> <p><b>Note:</b> By default, the parameter value is set to <b>C1OFFRST</b>. You can change the characteristic type, if required. However, you must specify a characteristic type where the characteristic entity is set to <b>Account</b>.</p>	Yes

Parameter	Description	Mandatory (Yes or No)
State of Issue Characteristic Type	<p>Used to specify the characteristic type which you want to use to indicate whether the members are eligible for the state assessment fee. This type of characteristic is defined on the policy.</p> <p><b>Note:</b> By default, the parameter value is set to <b>C1STISSE</b>. You can change the characteristic type, if required. However, you must specify a characteristic type where the characteristic entity is set to <b>Policy</b>.</p>	Yes
Days to Calculate Hold Request End Date	<p>Used to specify the number of days. It is used to calculate the hold request end date (which is hold request start date + specified number of days).</p> <p><b>Note:</b> By default, the parameter value is set to <b>5</b>.</p>	No
Proration Rule Characteristic Type	<p>Used to specify the characteristic type which you want to use to indicate how premium must be prorated. This type of characteristic is defined on the policy.</p> <p><b>Note:</b> By default, the parameter value is set to <b>C1PRTNRL</b>. You can change the characteristic type, if required. However, you must specify a characteristic type where the characteristic entity is set to <b>Policy</b>.</p>	Yes
Policy Plan Business Object Characteristic Type	<p>Used to specify the characteristic type which you want to use to store the business object using which the policy plan must be created. This type of characteristic is defined on the policy type.</p> <p><b>Note:</b> By default, the parameter value is set to <b>C1PPLNBO</b>. You can change the characteristic type, if required. However, you must specify a characteristic type where the characteristic entity is set to <b>Policy Type</b>.</p>	Yes
External Source System Status Reason Characteristic Type	<p>Used to specify the characteristic type which you want to use to store the external source system status reason. Each status reason configured for a policy status is mapped to an external source system status reason. The system uses this characteristic to derive the status reason configured in ORMB while reinstating or terminating the policy.</p> <p><b>Note:</b> By default, the parameter value is set to <b>C1PRSRSN</b>. You can change the characteristic type, if required. However, you must specify a characteristic type where the characteristic entity is set to <b>Status Reason</b>.</p>	Yes

Parameter	Description	Mandatory (Yes or No)
Plan Effective Date Characteristic Type	<p>Used to specify the characteristic type which you want to use to store the date from when the policy plan is effective. This type of characteristic is defined on the policy plan.</p> <p><b>Note:</b> By default, the parameter value is set to <b>C1PLEFDT</b>. You can change the characteristic type, if required. However, you must specify a characteristic type where the characteristic entity is set to <b>Policy Plan</b>.</p>	Yes
Policy Type	<p>Used to indicate the policy type. The system derives the policy business object (using which the policy must be created) from the policy type.</p> <p><b>Note:</b> By default, the parameter value is set to <b>INDIVIDUAL</b>. You can change the parameter value, if required. However, you must specify a policy type which is already defined in the system.</p>	No
Account Identifier Type	<p>Used to indicate the account identifier type against which you want to store the account number.</p> <p><b>Note:</b> By default, the parameter value is set to <b>C1_F_ANO</b>. You can change the parameter value, if required. However, you must specify an account identifier type which is already defined in the system.</p>	No
Membership Characteristic Type	<p>Used to specify the characteristic type which you want to use to store the membership ID. This type of characteristic is defined on the billable charge. The system uses this characteristic to derive the packaged savings billable charges whose corresponding bill segments must be canceled on the policy termination.</p> <p><b>Note:</b> By default, the parameter value is set to <b>C1MMBRSH</b>. You can change the characteristic type, if required. However, you must specify a characteristic type where the characteristic entity is set to <b>Billable Charge</b>.</p>	Yes
Add Days to Billable Charge End Date	<p>Used to specify the number of days. It is used to calculate the billable charge end date (which is billable charge existing end date + specified number of days).</p>	No



Parameter	Description	Mandatory (Yes or No)
Bill Segment Cancel Reason	<p>Used to indicate the cancel reason which you want to use during packaged savings bill segment cancelation on the policy termination.</p> <p><b>Note:</b> By default, the parameter value is set to <b>MASS</b>. You can change the parameter value, if required. However, you must specify a bill cancel reason which is already defined in the system.</p>	No
Member Count Service Quantity Identifier	<p>Used to indicate the service quantity identifier (SQI) against which you want to store the number of members in the policy plan. The system uses this SQI while creating the premium billable charges.</p> <p><b>Note:</b> By default, the parameter value is set to <b>MEMCOUNT</b>. You can change the parameter value, if required. However, you must specify a service quantity identifier which is already defined in the system.</p>	No
Non-Eligibility Based Contract Type	<p>Used to specify the contract type using which you want to create the non-eligibility based contract. The system then uses this contract to create non-eligibility based billable charges.</p> <p><b>Note:</b> By default, the parameter value is set to <b>NEBFEEES</b>. You can change the parameter value, if required. However, you must specify a contract type which is already defined in the system.</p>	No
Franchise Indicator Characteristic Type	<p>Used to specify the characteristic type which you want to use to indicate whether the parent person is a franchise. This type of characteristic is defined on the person.</p> <p><b>Note:</b> By default, the parameter value is set to <b>C1FRANCD</b>. You can change the characteristic type, if required. However, you must specify a characteristic type where the characteristic entity is set to <b>Person</b>.</p>	Yes

Parameter	Description	Mandatory (Yes or No)
Product Characteristic Type	<p>Used to specify the characteristic type which you want to use to indicate the product to which the price item is mapped. This type of characteristic is defined on the price item.</p> <p><b>Note:</b> By default, the parameter value is set to <b>CIPRODUC</b>. You can change the characteristic type, if required. However, you must specify a characteristic type where the characteristic entity is set to <b>Price Item</b>.</p>	Yes
Plan Activity Date Characteristic Type	<p>Used to specify the characteristic type which you want to use to store the plan activity date. This type of characteristic is defined on the policy plan.</p> <p><b>Note:</b> By default, the parameter value is set to <b>CIPLACDT</b>. You can change the characteristic type, if required. However, you must specify a characteristic type where the characteristic entity is set to <b>Policy Plan</b>.</p>	Yes
Non Integrated Packaged Savings Indicator Characteristic Type	<p>Used to specify the characteristic type which you want to use to indicate whether the packaged savings is non-integrated. This type of characteristic is defined on the billable charge.</p> <p><b>Note:</b> By default, the parameter value is set to <b>CIPSNINT</b>. You can change the characteristic type, if required. However, you must specify a characteristic type where the characteristic entity is set to <b>Billable Charge</b>.</p>	Yes
Override Collection Class Characteristic Type	<p>Used to specify the characteristic type which you want to use to store the collection class. This type of characteristic is defined on the person. The system then uses this characteristic to override the collection class of all accounts where the person is the main customer.</p> <p><b>Note:</b> By default, the parameter value is set to <b>CIOVCOLL</b>. You can change the characteristic type, if required. However, you must specify a characteristic type where the characteristic entity is set to <b>Person</b>.</p>	Yes

Parameter	Description	Mandatory (Yes or No)
Override Postpone Credit Review Date Characteristic Type	<p>Used to specify the characteristic type which you want to use to store the postpone credit review date. This type of characteristic is defined on the person. The system then uses this characteristic to override the postpone credit review date of all accounts where the person is the main customer.</p> <p><b>Note:</b> By default, the parameter value is set to <b>CIOVRWDT</b>. You can change the characteristic type, if required. However, you must specify a characteristic type where the characteristic entity is set to <b>Person</b>.</p>	Yes
Lock Box Characteristic Type	<p>Used to specify the characteristic type which you want to use to store the person ID. This type of characteristic is defined on the account.</p> <p><b>Note:</b> By default, the parameter value is set to <b>CILCKBX</b>. You can change the characteristic type, if required. However, you must specify a characteristic type where the characteristic entity is set to <b>Account</b>.</p>	Yes
Auto Pay Route Type Characteristic Type	<p>Used to specify the characteristic type which you want to use to store the auto pay route type. This type of characteristic is defined on the person. The system then uses this characteristic of a person to update auto pay route type for all accounts where the person is linked to the accounts through the <b>CILCKBX</b> characteristic.</p> <p><b>Note:</b> By default, the parameter value is set to <b>CIAPAYRT</b>. You can change the characteristic type, if required. However, you must specify a characteristic type where the characteristic entity is set to <b>Person</b>.</p>	Yes
Hold Request Type	<p>Used to specify the hold request type using which you want to create the hold request for an account.</p> <p><b>Note:</b> By default, the parameter value is set to <b>DIASTER</b>. You can change the parameter value, if required. However, you must specify a hold request type which is already defined in the system.</p>	No

Parameter	Description	Mandatory (Yes or No)
Price Item Business Object	Used to specify the business object using which you want to create a price item.  <b>Note:</b> By default, the parameter value is set to <b>C1_PRICEITEM_BO</b> . You can change the parameter value, if required. However, you must specify a business object which is already defined in the system.	Yes
Address Business Object	Used to specify the business object using which you want to create an address.  <b>Note:</b> By default, the parameter value is set to <b>C1-Address</b> . You can change the parameter value, if required. However, you must specify a business object which is already defined in the system.	Yes

### C1-TODORETRY

This algorithm is invoked when the status of the customer or membership inbound message is changed to **Rejected**. It checks whether the maximum retry attempts are met. If the retry attempt is less than or equal to the value defined in the **Maximum Retry** parameter, the status of the inbound message is changed to **Pending**. However, if the retry attempt is greater than the value defined in the **Maximum Retry** parameter, the status of the inbound message remains as **Rejected**.

**Note:** This algorithm is invoked only when the customer or membership inbound message is validated and processed through the batch process.

It contains the following parameters:

- **Maximum Retry** – Used to specify the maximum number of times the inbound message can be revalidated and reprocessed on failure.
- **Maximum Retry Element Name** – This parameter is not used at the moment.

If you do not specify any value for the **Maximum Retry** parameter, the system uses the value defined in the **To Do Maximum Retries** status option (which is defined in the lifecycle of the **C1-CustomerInboundMessage** and **C1-MemberInboundMessage** business object) to check whether the maximum retry attempts are met. If the value is not specified for the **To Do Maximum Retries** status option, the system does not allow revalidating and reprocessing an inbound message, and the status of the inbound message remains as **Rejected**.

### C1-TDCRINMSG

This algorithm is invoked when the status of the customer or membership inbound message is changed to **Rejected**. It creates a To Do using the specified To Do type and assigns it to users with the specified To Do role.

It contains the following parameters:

- **To Do Type** - Used to specify the type of notification that you want to generate when the inbound message validation or processing fails.
- **To Do Role** - Used to specify the To Do role to indicate the users to whom you want to send the notification when the inbound message validation or processing fails.

The rest of the parameters, such as **To Do Type Element Name**, **To Do Role Element Name**, **Message Category**, **Message Number**, **Characteristic Type For Log Entry**, **To Do Sort Keys Retriever Script**, **Discard Cancel Terminate Reason Element**, **Discard Cancel Terminate Reason**, **Retry Frequency**, and **Retry Frequency Element Name**, are not used at the moment.

## Customer Inbound Message XML Format

**Note:** We recommend you to refer the Customer Inbound Message schema in parallel while understanding the below mentioned tags. This will help you to understand how the tags are nested in the schema.

Before calling the **C1-CustomerStructureInboundMessage** inbound web service, you need to ensure that the customer inbound message contains the following tags:

Tag Name	Tag Description	Mandatory (Yes or No)												
schema	Used to specify the tags of a customer inbound message.	Yes												
characteristics	<p>You can use this tag within the following tags:</p> <table border="1"> <thead> <tr> <th>If this tag is used within...</th> <th>Then the purpose of the characteristics tag is...</th> </tr> </thead> <tbody> <tr> <td>schema</td> <td>Used to specify a list of characteristics for the customer inbound message.</td> </tr> <tr> <td>customerData</td> <td>Used to specify a list of characteristics for the person.</td> </tr> <tr> <td>billGroup</td> <td>Used to specify a list of characteristics for the bill group (i.e. account).</td> </tr> <tr> <td>policyData</td> <td>Used to specify a list of characteristics for the policy.</td> </tr> <tr> <td>plan</td> <td>Used to specify a list of characteristics for the policy plan.</td> </tr> </tbody> </table>	If this tag is used within...	Then the purpose of the characteristics tag is...	schema	Used to specify a list of characteristics for the customer inbound message.	customerData	Used to specify a list of characteristics for the person.	billGroup	Used to specify a list of characteristics for the bill group (i.e. account).	policyData	Used to specify a list of characteristics for the policy.	plan	Used to specify a list of characteristics for the policy plan.	No
If this tag is used within...	Then the purpose of the characteristics tag is...													
schema	Used to specify a list of characteristics for the customer inbound message.													
customerData	Used to specify a list of characteristics for the person.													
billGroup	Used to specify a list of characteristics for the bill group (i.e. account).													
policyData	Used to specify a list of characteristics for the policy.													
plan	Used to specify a list of characteristics for the policy plan.													
inboundMessageCharacteristic	Used to specify a characteristic for the customer inbound message.	No												
adhocCharacteristicValue	Used to specify the value for the adhoc characteristic type.	Yes (Conditional) <table border="1"> <tr> <td> <p><b>Note:</b> This data is required while defining or editing an adhoc characteristic of the customer inbound message.</p> </td> </tr> </table>	<p><b>Note:</b> This data is required while defining or editing an adhoc characteristic of the customer inbound message.</p>											
<p><b>Note:</b> This data is required while defining or editing an adhoc characteristic of the customer inbound message.</p>														

Tag Name	Tag Description	Mandatory (Yes or No)						
characteristicType	<p>You can use this tag within the following tags:</p> <table border="1" data-bbox="573 268 1162 1923"> <thead> <tr> <th data-bbox="573 268 894 415">If this tag is used within...</th> <th data-bbox="894 268 1162 415">Then the purpose of the characteristicType tag is...</th> </tr> </thead> <tbody> <tr> <td data-bbox="573 415 894 720">inboundMessageCharacteristic</td> <td data-bbox="894 415 1162 720">Used to specify the characteristic type. Here, you must specify a characteristic type where the characteristic entity is set to <b>Inbound Message</b>.</td> </tr> <tr> <td data-bbox="573 720 894 1923">characteristicsList</td> <td data-bbox="894 720 1162 1923">           Used to specify the characteristic type. If you are defining a characteristic for a:           <ul style="list-style-type: none"> <li>• <b>Customer</b> - You must specify a characteristic type where the characteristic entity is set to <b>Person</b>.</li> <li>• <b>Bill Group</b> - You must specify a characteristic type where the characteristic entity is set to <b>Account</b>.</li> <li>• <b>Policy</b> - You must specify a characteristic type where the characteristic entity is set to <b>Policy</b>.</li> <li>• <b>Policy Plan</b> - You must specify a characteristic type where the characteristic entity is set to <b>Policy Plan</b>.</li> </ul> </td> </tr> </tbody> </table>	If this tag is used within...	Then the purpose of the characteristicType tag is...	inboundMessageCharacteristic	Used to specify the characteristic type. Here, you must specify a characteristic type where the characteristic entity is set to <b>Inbound Message</b> .	characteristicsList	Used to specify the characteristic type. If you are defining a characteristic for a: <ul style="list-style-type: none"> <li>• <b>Customer</b> - You must specify a characteristic type where the characteristic entity is set to <b>Person</b>.</li> <li>• <b>Bill Group</b> - You must specify a characteristic type where the characteristic entity is set to <b>Account</b>.</li> <li>• <b>Policy</b> - You must specify a characteristic type where the characteristic entity is set to <b>Policy</b>.</li> <li>• <b>Policy Plan</b> - You must specify a characteristic type where the characteristic entity is set to <b>Policy Plan</b>.</li> </ul>	<p>Yes (Conditional)</p> <div data-bbox="1182 268 1464 405" style="border: 1px solid black; padding: 5px;"> <p><b>Note:</b> This data is required while defining or editing a characteristic of the respective entity.</p> </div>
If this tag is used within...	Then the purpose of the characteristicType tag is...							
inboundMessageCharacteristic	Used to specify the characteristic type. Here, you must specify a characteristic type where the characteristic entity is set to <b>Inbound Message</b> .							
characteristicsList	Used to specify the characteristic type. If you are defining a characteristic for a: <ul style="list-style-type: none"> <li>• <b>Customer</b> - You must specify a characteristic type where the characteristic entity is set to <b>Person</b>.</li> <li>• <b>Bill Group</b> - You must specify a characteristic type where the characteristic entity is set to <b>Account</b>.</li> <li>• <b>Policy</b> - You must specify a characteristic type where the characteristic entity is set to <b>Policy</b>.</li> <li>• <b>Policy Plan</b> - You must specify a characteristic type where the characteristic entity is set to <b>Policy Plan</b>.</li> </ul>							

Tag Name	Tag Description	Mandatory (Yes or No)												
effectiveDate	You can use this tag within the following tags:	No												
	<table border="1"> <thead> <tr> <th data-bbox="570 268 943 415">If this tag is used within...</th> <th data-bbox="943 268 1159 415">Then the purpose of the effectiveDate tag is...</th> </tr> </thead> <tbody> <tr> <td data-bbox="570 415 943 688">inboundMessageCharacteristic</td> <td data-bbox="943 415 1159 688">Used to specify the date from when the characteristic is effective for the customer inbound message.</td> </tr> <tr> <td data-bbox="570 688 943 1024">characteristicsList</td> <td data-bbox="943 688 1159 1024">Used to specify the date from when the characteristic is effective for the respective entity (i.e. customer, bill group (i.e. account), policy, or policy plan).</td> </tr> </tbody> </table>	If this tag is used within...	Then the purpose of the effectiveDate tag is...	inboundMessageCharacteristic	Used to specify the date from when the characteristic is effective for the customer inbound message.	characteristicsList	Used to specify the date from when the characteristic is effective for the respective entity (i.e. customer, bill group (i.e. account), policy, or policy plan).							
If this tag is used within...	Then the purpose of the effectiveDate tag is...													
inboundMessageCharacteristic	Used to specify the date from when the characteristic is effective for the customer inbound message.													
characteristicsList	Used to specify the date from when the characteristic is effective for the respective entity (i.e. customer, bill group (i.e. account), policy, or policy plan).													
	<p><b>Note:</b></p> <p>You must specify the date in the YYYY-MM-DD format.</p> <p>If you do not specify the effective date, the system uses the below mentioned date while defining a characteristic for the following:</p> <table border="1"> <thead> <tr> <th data-bbox="570 1268 683 1318">Entity</th> <th data-bbox="683 1268 889 1318">Effective Date</th> <th data-bbox="889 1268 1159 1318">Description</th> </tr> </thead> <tbody> <tr> <td data-bbox="570 1318 683 1717">Person</td> <td data-bbox="683 1318 889 1717">Earliest Policy Effective Date</td> <td data-bbox="889 1318 1159 1717">A person might have multiple policies. For example, P1 effective from 01-01-2016 and P2 effective from 01-01-2017. In such case, the system uses the effective date of the policy which is the earliest (i.e. P1) while defining characteristic for the person.</td> </tr> <tr> <td data-bbox="570 1717 683 1927">Policy</td> <td data-bbox="683 1717 889 1927">Policy Effective Date</td> <td data-bbox="889 1717 1159 1927">The system uses the date from when the policy is effective while defining characteristic for the policy.</td> </tr> <tr> <td data-bbox="570 1927 683 2100">Plan</td> <td data-bbox="683 1927 889 2100">Plan Effective Date</td> <td data-bbox="889 1927 1159 2100">The system uses the date from when the policy plan is effective in the policy while defining characteristic</td> </tr> </tbody> </table>	Entity	Effective Date	Description	Person	Earliest Policy Effective Date	A person might have multiple policies. For example, P1 effective from 01-01-2016 and P2 effective from 01-01-2017. In such case, the system uses the effective date of the policy which is the earliest (i.e. P1) while defining characteristic for the person.	Policy	Policy Effective Date	The system uses the date from when the policy is effective while defining characteristic for the policy.	Plan	Plan Effective Date	The system uses the date from when the policy plan is effective in the policy while defining characteristic	
Entity	Effective Date	Description												
Person	Earliest Policy Effective Date	A person might have multiple policies. For example, P1 effective from 01-01-2016 and P2 effective from 01-01-2017. In such case, the system uses the effective date of the policy which is the earliest (i.e. P1) while defining characteristic for the person.												
Policy	Policy Effective Date	The system uses the date from when the policy is effective while defining characteristic for the policy.												
Plan	Plan Effective Date	The system uses the date from when the policy plan is effective in the policy while defining characteristic												

Tag Name	Tag Description	Mandatory (Yes or No)						
characteristicValue	<p>You can use this tag within the following tags:</p> <table border="1"> <thead> <tr> <th>If this tag is used within...</th> <th>Then the purpose of the characteristicValue tag is...</th> </tr> </thead> <tbody> <tr> <td>inboundMessageCharacteristic</td> <td>Used to specify the value for the predefined characteristic type.</td> </tr> <tr> <td>characteristicsList</td> <td>Used to specify the value for the characteristic type.</td> </tr> </tbody> </table>	If this tag is used within...	Then the purpose of the characteristicValue tag is...	inboundMessageCharacteristic	Used to specify the value for the predefined characteristic type.	characteristicsList	Used to specify the value for the characteristic type.	<p>Yes (Conditional)</p> <p><b>Note:</b> This data is required while defining or editing a characteristic of the respective entity.</p>
If this tag is used within...	Then the purpose of the characteristicValue tag is...							
inboundMessageCharacteristic	Used to specify the value for the predefined characteristic type.							
characteristicsList	Used to specify the value for the characteristic type.							
characteristicValueForeignKey	Used to specify the first value for the foreign key characteristic type.	<p>Yes (Conditional)</p> <p><b>Note:</b> This data is required while defining or editing a foreign key characteristic of the customer inbound message.</p>						
characteristicValueFK2	Used to specify the second value for the foreign key characteristic type.	No						
characteristicValueFK3	Used to specify the third value for the foreign key characteristic type.	No						
characteristicValueFK4	Used to specify the fourth value for the foreign key characteristic type.	No						
characteristicValueFK5	Used to specify the fifth value for the foreign key characteristic type.	No						
customerStructureMessage	Used to specify the details of the customer including the header information for the customer inbound message.	Yes						
headerData	Used to specify the header information for the customer inbound message.	Yes						



Tag Name	Tag Description	Mandatory (Yes or No)								
messageType	<p>You can use this tag within the following tags:</p> <table border="1" data-bbox="573 268 1159 848"> <thead> <tr> <th data-bbox="573 268 829 352">If this tag is used within...</th> <th data-bbox="829 268 1159 352">Then the purpose of the messageType tag is...</th> </tr> </thead> <tbody> <tr> <td data-bbox="573 352 829 667">schema</td> <td data-bbox="829 352 1159 667">           Indicates the inbound message type using which the customer inbound message is created in the system.   <b>Note:</b> The system refers the value from within the <b>headerData</b> tag.         </td> </tr> <tr> <td data-bbox="573 667 829 848">headerData</td> <td data-bbox="829 667 1159 848">           Used to specify the inbound message type using which the customer inbound message should be created in the system.         </td> </tr> </tbody> </table> <p><b>Note:</b> You must specify a valid customer inbound message type which is in the <b>Active</b> status.</p>	If this tag is used within...	Then the purpose of the messageType tag is...	schema	Indicates the inbound message type using which the customer inbound message is created in the system.  <b>Note:</b> The system refers the value from within the <b>headerData</b> tag.	headerData	Used to specify the inbound message type using which the customer inbound message should be created in the system.	Yes		
If this tag is used within...	Then the purpose of the messageType tag is...									
schema	Indicates the inbound message type using which the customer inbound message is created in the system.  <b>Note:</b> The system refers the value from within the <b>headerData</b> tag.									
headerData	Used to specify the inbound message type using which the customer inbound message should be created in the system.									
messageBatchID	Used to indicate the external batch job or batch run number through which the customer inbound message is created.	Yes								
sourceSystem	<p>You can use this tag within the following tags:</p> <table border="1" data-bbox="573 1155 1159 1785"> <thead> <tr> <th data-bbox="573 1155 829 1239">If this tag is used within...</th> <th data-bbox="829 1155 1159 1239">Then the purpose of the sourceSystem tag is...</th> </tr> </thead> <tbody> <tr> <td data-bbox="573 1239 829 1522">schema</td> <td data-bbox="829 1239 1159 1522">           Indicates the external system from where the customer inbound message is received.   <b>Note:</b> The system refers the value from within the <b>headerData</b> tag.         </td> </tr> <tr> <td data-bbox="573 1522 829 1669">headerData</td> <td data-bbox="829 1522 1159 1669">           Used to indicate the external system from where the customer inbound message is received.         </td> </tr> <tr> <td data-bbox="573 1669 829 1785">policyData</td> <td data-bbox="829 1669 1159 1785">           Used to indicate the source system from where the policy is originated.         </td> </tr> </tbody> </table> <p><b>Note:</b> You must specify a source system which is already defined in the <b>C1-SourceSystemLookup</b> extendable lookup. It must be in the <b>Active</b> status.</p>	If this tag is used within...	Then the purpose of the sourceSystem tag is...	schema	Indicates the external system from where the customer inbound message is received.  <b>Note:</b> The system refers the value from within the <b>headerData</b> tag.	headerData	Used to indicate the external system from where the customer inbound message is received.	policyData	Used to indicate the source system from where the policy is originated.	Yes
If this tag is used within...	Then the purpose of the sourceSystem tag is...									
schema	Indicates the external system from where the customer inbound message is received.  <b>Note:</b> The system refers the value from within the <b>headerData</b> tag.									
headerData	Used to indicate the external system from where the customer inbound message is received.									
policyData	Used to indicate the source system from where the policy is originated.									

Tag Name	Tag Description	Mandatory (Yes or No)						
sourceSystemTransID	Used to indicate the transaction in the external source system which resulted in the customer inbound message.	No						
sourceSystemSourceID	Used to specify the external source system ID.	Yes						
bo	<p>You can use this tag within the following tags:</p> <table border="1"> <thead> <tr> <th>If this tag is used within...</th> <th>Then the purpose of the bo tag is...</th> </tr> </thead> <tbody> <tr> <td>schema</td> <td> <p>Indicates the business object using which the customer inbound message is created in the system.</p> <p><b>Note:</b> The system refers the value from within the <b>headerData</b> tag.</p> </td> </tr> <tr> <td>headerData</td> <td> <p>Used to indicate the business object using which the customer inbound message should be created in the system. The valid value is:</p> <ul style="list-style-type: none"> <li>• C1- CustomerInboundMessage</li> </ul> </td> </tr> </tbody> </table>	If this tag is used within...	Then the purpose of the bo tag is...	schema	<p>Indicates the business object using which the customer inbound message is created in the system.</p> <p><b>Note:</b> The system refers the value from within the <b>headerData</b> tag.</p>	headerData	<p>Used to indicate the business object using which the customer inbound message should be created in the system. The valid value is:</p> <ul style="list-style-type: none"> <li>• C1- CustomerInboundMessage</li> </ul>	Yes
If this tag is used within...	Then the purpose of the bo tag is...							
schema	<p>Indicates the business object using which the customer inbound message is created in the system.</p> <p><b>Note:</b> The system refers the value from within the <b>headerData</b> tag.</p>							
headerData	<p>Used to indicate the business object using which the customer inbound message should be created in the system. The valid value is:</p> <ul style="list-style-type: none"> <li>• C1- CustomerInboundMessage</li> </ul>							
transactionType	<p>Used to indicate the type of the transaction. The valid values are:</p> <ul style="list-style-type: none"> <li>• <b>CHNG</b> - Used when you want to update the details of a person, account, contract, fully-insured policy, policy plan, packaged savings, and billable charge.</li> <li>• <b>NEW</b> - Used when you want to create a person, account, contract, fully-insured policy, policy plan, packaged savings, and billable charge.</li> <li>• <b>REIN</b> - Used when you want to reinstate a fully-insured policy.</li> <li>• <b>TERM</b> - Used when you want to terminate a fully-insured policy.</li> </ul>	Yes						
externalTransactionType	Used to specify the corresponding transaction type used in the external source system.	No						
customerStructureData	Used to specify the customer information, such as details of the person, bill group (i.e. account), fully-insured policy, and policy plan.	Yes						

Tag Name	Tag Description	Mandatory (Yes or No)						
customerData	Used to specify the details of the person.	Yes (Conditional) <b>Note:</b> This data is required while defining or editing a person.						
customerName	Used to specify the name of the person.	Yes (Conditional) <b>Note:</b> This data is required while defining a person.						
customerType	Used to indicate the type of the person. <b>Note:</b> You must specify a value which is already defined in the <b>PER_OR_BUS_FLG</b> lookup field. It must be in the <b>Active</b> status.	Yes (Conditional) <b>Note:</b> This data is required while defining a person.						
Id	You can use this tag within the following tags: <table border="1"> <thead> <tr> <th>If this tag is used within...</th> <th>Then the purpose of the Id tag is...</th> </tr> </thead> <tbody> <tr> <td>customerData</td> <td>Used to specify the identification details of the person.</td> </tr> <tr> <td>billGroup</td> <td>Used to specify the identification details of the bill group (i.e. account).</td> </tr> </tbody> </table> <b>Note:</b> You must specify one primary identifier for a person and account.	If this tag is used within...	Then the purpose of the Id tag is...	customerData	Used to specify the identification details of the person.	billGroup	Used to specify the identification details of the bill group (i.e. account).	Yes (Conditional) <b>Note:</b> This data is required while defining or editing the respective information.
If this tag is used within...	Then the purpose of the Id tag is...							
customerData	Used to specify the identification details of the person.							
billGroup	Used to specify the identification details of the bill group (i.e. account).							
IDType	You can use this tag within the following tags: <table border="1"> <thead> <tr> <th>If this tag is used within...</th> <th>Then the purpose of the IDType tag is...</th> </tr> </thead> <tbody> <tr> <td>Id</td> <td>Used to specify the person or account identifier type.</td> </tr> <tr> <td>parentSection</td> <td>Used to specify the person identifier type.</td> </tr> </tbody> </table> <b>Note:</b> You must specify a person or account identifier type which is already defined in the system.	If this tag is used within...	Then the purpose of the IDType tag is...	Id	Used to specify the person or account identifier type.	parentSection	Used to specify the person identifier type.	Yes (Conditional) <b>Note:</b> This data is required in the following scenarios: <ul style="list-style-type: none"> <li>While defining or editing the identification details of a person and account.</li> <li>While defining or editing a person to person relationship.</li> </ul>
If this tag is used within...	Then the purpose of the IDType tag is...							
Id	Used to specify the person or account identifier type.							
parentSection	Used to specify the person identifier type.							

Tag Name	Tag Description	Mandatory (Yes or No)						
IDValue	<p>You can use this tag within the following tags:</p> <table border="1"> <thead> <tr> <th>If this tag is used within...</th> <th>Then the purpose of the IDValue tag is...</th> </tr> </thead> <tbody> <tr> <td>Id</td> <td>Used to specify the person or account identifier.</td> </tr> <tr> <td>parentSection</td> <td>Used to indicate the person with whom you want to establish the person to person relationship.</td> </tr> </tbody> </table>	If this tag is used within...	Then the purpose of the IDValue tag is...	Id	Used to specify the person or account identifier.	parentSection	Used to indicate the person with whom you want to establish the person to person relationship.	<p>Yes (Conditional)</p> <p><b>Note:</b> This data is required in the following scenarios:</p> <ul style="list-style-type: none"> <li>• While defining or editing the identification details of a person and account.</li> <li>• While defining or editing a person to person relationship.</li> </ul>
If this tag is used within...	Then the purpose of the IDValue tag is...							
Id	Used to specify the person or account identifier.							
parentSection	Used to indicate the person with whom you want to establish the person to person relationship.							
isPrimary	<p>Used to indicate whether the person or account identifier is a primary identifier. The valid values are:</p> <ul style="list-style-type: none"> <li>• Y</li> <li>• N</li> </ul> <p><b>Note:</b> If you do not specify the value, by default, it is set to N.</p>	No						
parentSection	Used to specify the details of the parent person with whom you want to establish the person's relationship.	No						
relationshipType	<p>Used to indicate how the parent person is related to the person.</p> <p><b>Note:</b> You must specify a person relationship type which is already defined in the system.</p>	<p>Yes (Conditional)Yes (Conditional)</p> <p><b>Note:</b> This data is required while defining or editing a person to person relationship.</p>						
isFranchiseBillingIndicator	<p>Used to indicate whether the parent person is the franchise. The valid values are:</p> <ul style="list-style-type: none"> <li>• <b>Y</b> - If you specify the value as <b>Y</b>, the system will create the parent-child relationship and add the person's account or contract details in the parent person's existing statement construct.</li> <li>• <b>N</b> - If you specify the value as <b>N</b>, the system will end the parent-child relationship and the person's account or contract details in the parent person's existing statement construct.</li> </ul>	No						
characteristicsList	Used to specify a characteristic for the respective entity (such as person, bill group (i.e. account), policy, or policy plan).	<p>Yes (Conditional)</p> <p><b>Note:</b> This data is required while defining or editing a characteristic of the respective entity.</p>						

Tag Name	Tag Description	Mandatory (Yes or No)						
address	<p>You can use this tag within the following tags:</p> <table border="1" data-bbox="573 268 1154 516"> <thead> <tr> <th data-bbox="573 268 846 352">If this tag is used within...</th> <th data-bbox="846 268 1154 352">Then the purpose of the address tag is...</th> </tr> </thead> <tbody> <tr> <td data-bbox="573 352 846 436">customerData</td> <td data-bbox="846 352 1154 436">Used to specify the address of the person.</td> </tr> <tr> <td data-bbox="573 436 846 516">billGroup</td> <td data-bbox="846 436 1154 516">Used to specify the address of the account.</td> </tr> </tbody> </table>	If this tag is used within...	Then the purpose of the address tag is...	customerData	Used to specify the address of the person.	billGroup	Used to specify the address of the account.	<p>Yes (Conditional)</p> <p><b>Note:</b> This data is required while defining or editing the address of the respective entity.</p>
If this tag is used within...	Then the purpose of the address tag is...							
customerData	Used to specify the address of the person.							
billGroup	Used to specify the address of the account.							
addressEffDate	<p>Used to specify the date from when the address is effective.</p> <p><b>Note:</b> You must specify the date in the YYYY-MM-DD format. If you do not specify the date, by default, the system sets the effective date to the date when the address is created in the system through the customer inbound message.</p>	<p>Yes (Conditional)</p> <p><b>Note:</b> This data is required while editing the address of the respective entity.</p>						
addressType	<p>Used to indicate the type of address. The valid values are:</p> <ul style="list-style-type: none"> <li>• <b>MAIN</b> - Indicates that the address is the person's mailing address. You can use this address type while specifying the address for the person and account.</li> <li>• <b>SEAS</b> - Indicates that the address is the person's seasonal address. You can use this address type while specifying the address for the person.</li> <li>• <b>OVRD</b> - Indicates that the address is the account's override address. You can use this address type while specifying the address for the account.</li> </ul> <p><b>Note:</b> If you do not specify the address type, by default, it is set to <b>MAIN</b>. You must specify an address type which is already defined in the <b>ADDRESS_TYPE_FLG</b> lookup field. It must be in the <b>Active</b> status.</p>	<p>Yes (Conditional)</p> <p><b>Note:</b> This data is required while editing the address of the respective entity.</p>						
MailingName	<p>Used to specify the name using which the person should be addressed in the mail communication. The system also uses the mailing name in the bills, letters, quotes, and statements.</p>	<p>No</p>						

Tag Name	Tag Description	Mandatory (Yes or No)						
address1	Used to specify the first line of the address. It may contain details, such as the house number.	Yes (Conditional) <b>Note:</b> This data is required while defining or editing the address of the respective entity.						
address2	Used to specify the second line of the address. It may contain details, such as the apartment name.	No						
address3	Used to specify the third line of the address. It may contain details, such as the street name.	No						
city	Used to specify the city name.	No						
state	Used to indicate the state where the city is located.	No						
zip	Used to specify the zip code of the address.	No						
country	Used to indicate the country where the person or account is located.	Yes (Conditional) <b>Note:</b> This data is required while defining or editing the address of the respective entity.						
attentionName	Used to specify the fourth line of the address. It may contain the landmark details.	No						
email	You can use this tag within the following tags: <table border="1" data-bbox="571 1110 1161 1392"> <thead> <tr> <th>If this tag is used within...</th> <th>Then the purpose of the email tag is...</th> </tr> </thead> <tbody> <tr> <td>customerData</td> <td>Used to specify the email ID of the person.</td> </tr> <tr> <td>billGroup</td> <td>Used to specify the email ID of the account's main customer.</td> </tr> </tbody> </table>	If this tag is used within...	Then the purpose of the email tag is...	customerData	Used to specify the email ID of the person.	billGroup	Used to specify the email ID of the account's main customer.	No
If this tag is used within...	Then the purpose of the email tag is...							
customerData	Used to specify the email ID of the person.							
billGroup	Used to specify the email ID of the account's main customer.							
phones	You can use this tag within the following tags: <table border="1" data-bbox="571 1484 1161 1766"> <thead> <tr> <th>If this tag is used within...</th> <th>Then the purpose of the phones tag is...</th> </tr> </thead> <tbody> <tr> <td>customerData</td> <td>Used to specify the phone details of the person.</td> </tr> <tr> <td>billGroup</td> <td>Used to specify the phone details of the account's main customer.</td> </tr> </tbody> </table>	If this tag is used within...	Then the purpose of the phones tag is...	customerData	Used to specify the phone details of the person.	billGroup	Used to specify the phone details of the account's main customer.	Yes (Conditional) <b>Note:</b> This data is required while defining or editing the phone details of the respective entity.
If this tag is used within...	Then the purpose of the phones tag is...							
customerData	Used to specify the phone details of the person.							
billGroup	Used to specify the phone details of the account's main customer.							

Tag Name	Tag Description	Mandatory (Yes or No)
phoneType	Used to indicate the type of phone.  <b>Note:</b> You must specify a phone type which is already defined in the system.	Yes (Conditional)  <b>Note:</b> This data is required while defining or editing the phone details of the respective entity.
phoneValue	Used to specify the phone number of the person or account's main customer.	Yes (Conditional)  <b>Note:</b> This data is required while defining or editing the phone details of the respective entity.
billGroup	Used to specify the account details of a person.	Yes (Conditional)  <b>Note:</b> This data is required while defining or editing a bill group (i.e. account).
customerClass	Used to indicate the customer class to which the account belongs.  <b>Note:</b> You must specify a customer class which is already defined in the system.	Yes (Conditional)  <b>Note:</b> This data is required while defining a bill group (i.e. account).
billCycle	Used to indicate the bill cycle for the account.  <b>Note:</b> You must specify a bill cycle which is already defined in the system and added in the <b>C1-BILLCYCLE</b> feature configuration.	Yes (Conditional)  <b>Note:</b> This data is required while defining a bill group (i.e. account).
division	Used to indicate the division to which the account belongs.  <b>Note:</b> You must specify a division which is already defined in the system.	Yes (Conditional)  <b>Note:</b> This data is required while defining a bill group (i.e. account).
billRouteType	Used to indicate how the account's bill must be sent to the main customer.  <b>Note:</b> You must specify a bill route type which is already defined in the system.	Yes (Conditional)  <b>Note:</b> This data is required while defining a bill group (i.e. account).
billGroupID	Used to specify the account number. It is stored as the primary account identifier in the system.  <b>Note:</b> The system stores the value against the account identifier type which is specified in the <b>Account Identifier Type</b> parameter of the <b>C1-CINMSGPRC</b> algorithm.	Yes (Conditional)  <b>Note:</b> This data is required while defining or editing a bill group (i.e. account).

Tag Name	Tag Description	Mandatory (Yes or No)
bankNumber	Used to indicate the bank account number through which the automatic payment must be done.	No
depositoryFinancialInstitution	Used to indicate the depository financial institution.	No
accountType	Used to indicate the type of the account. <b>Note:</b> You must specify an account type which is already defined in the <b>EXT_TYPE_FLG</b> lookup field. It must be in the <b>Active</b> status.	No
billAddressSource	Used to indicate whether the account's bill must be sent to the main customer's mailing address or to the main customer's account override address. The valid values are: <ul style="list-style-type: none"> <li>• PER</li> <li>• ACOV</li> </ul> <b>Note:</b> You must specify a value which is already defined in the <b>BILL_ADDR_SRCE_FLG</b> lookup field. It must be in the <b>Active</b> status.	Yes (Conditional) <b>Note:</b> This data is required while defining a bill group (i.e. account).
billToName	Used to specify the name using which you want to override the main customer's mailing name.	No
policyData	Used to specify the details of the fully-insured policy.	Yes (Conditional) <b>Note:</b> This data is required while defining or editing a fully-insured policy.
policyNumber	Used to specify the policy number.	Yes (Conditional) <b>Note:</b> This data is required while defining or editing a fully-insured policy.



Tag Name	Tag Description	Mandatory (Yes or No)						
endDate	<p>You can use this tag within the following tags:</p> <table border="1" data-bbox="573 268 1159 678"> <thead> <tr> <th data-bbox="573 268 846 352">If this tag is used within...</th> <th data-bbox="846 268 1159 352">Then the purpose of the endDate tag is...</th> </tr> </thead> <tbody> <tr> <td data-bbox="573 352 846 468">policyData</td> <td data-bbox="846 352 1159 468">Used to specify the date till when the policy is effective.</td> </tr> <tr> <td data-bbox="573 468 846 678">packageSavings</td> <td data-bbox="846 468 1159 678">Used to specify the date till when the packaged savings is effective on the policy. This date is then used as the end date of the billable charge.</td> </tr> </tbody> </table> <p><b>Note:</b> The end date cannot be earlier than the start date. You must specify the date in the YYYY-MM-DD format.</p>	If this tag is used within...	Then the purpose of the endDate tag is...	policyData	Used to specify the date till when the policy is effective.	packageSavings	Used to specify the date till when the packaged savings is effective on the policy. This date is then used as the end date of the billable charge.	<p>Yes (Conditional)</p> <p><b>Note:</b> This data is required while defining a fully-insured policy.</p>
If this tag is used within...	Then the purpose of the endDate tag is...							
policyData	Used to specify the date till when the policy is effective.							
packageSavings	Used to specify the date till when the packaged savings is effective on the policy. This date is then used as the end date of the billable charge.							
renewalDate	<p>Used to specify the date when you want to renew the fully-insured policy.</p> <p><b>Note:</b> On renewing a fully-insured policy, the status of the policy is changed to the status which is specified in the <b>Status on Policy Renewal</b> field of the respective inbound message type.</p>	<p>Yes (Conditional)</p> <p><b>Note:</b> This data is required while renewing a fully-insured policy.</p>						
policyName	<p>Used to specify the description for the fully-insured policy.</p>	<p>Yes (Conditional)</p> <p><b>Note:</b> This data is required while defining a fully-insured policy.</p>						
terminateDate	<p>Used to specify the date when you want to terminate the fully-insured policy.</p> <p><b>Note:</b> You must specify the date in the YYYY-MM-DD format. The termination date cannot be earlier than the policy start date. On terminating a fully-insured policy, the status of the policy is changed to the status which is specified in the <b>Status on Policy Termination</b> field of the respective inbound message type.</p>	<p>Yes (Conditional)</p> <p><b>Note:</b> This data is required while terminating a fully-insured policy.</p>						

Tag Name	Tag Description	Mandatory (Yes or No)
statusReason	<p>Used to indicate the reason why you want to terminate or reinstate the fully-insured policy.</p> <p><b>Note:</b> You must specify a reason which is defined for the respective status specified in the inbound message type.</p>	<p>Yes (Conditional)</p> <p><b>Note:</b> This data is required while terminating or reinstating a fully-insured policy.</p>
policyEffectiveDate	<p>Used to specify the date from when the policy is effective.</p> <p><b>Note:</b> The policy start date cannot be later than the policy end date.</p>	<p>Yes (Conditional)</p> <p><b>Note:</b> This data is required while defining a fully-insured policy.</p>
packageSavings	<p>Used to specify a list of packaged savings offered on the policy.</p>	<p>No</p>
packageSavings	<p>Used to specify the packaged savings offered on the policy.</p> <p><b>Note:</b> The packaged savings is configured as a price item in the system. You must specify a price item which is already defined in the system. On processing the customer inbound message, one billable charge is created for each packaged savings offered on the policy. The policy ID is stored as a characteristic on such billable charge.</p>	<p>Yes (Conditional)</p> <p><b>Note:</b> This data is required while defining or editing the packaged savings offered on the fully-insured policy.</p>
startDate	<p>Used to specify the date from when the packaged savings is offered on the policy. This date is then used as the start date of the billable charge.</p> <p><b>Note:</b> The start date cannot be later than the end date. You must specify the date in the YYYY-MM-DD format.</p>	<p>Yes (Conditional)</p> <p><b>Note:</b> This data is required while defining or editing the packaged savings offered on the fully-insured policy.</p>

Tag Name	Tag Description	Mandatory (Yes or No)
nonintegratedInd	<p>Used to indicate whether the packaged savings is non-integrated. The valid values are:</p> <ul style="list-style-type: none"> <li>• Y</li> <li>• N</li> </ul> <p><b>Note:</b> The value is stored as a characteristic on the billable charge. The system stores the value against the characteristic type which is specified in the <b>Non Integrated Packaged Savings Indicator Characteristic Type</b> parameter of the <b>C1-CINMSGPRC</b> algorithm. If you do not specify the value, by default, it is set to <b>N</b>.</p>	<p>Yes (Conditional)</p> <p><b>Note:</b> This data is required while editing the packaged savings offered on the fully-insured policy.</p>
plan	<p>Used to specify the details of the policy plan.</p>	<p>Yes (Conditional)</p> <p><b>Note:</b> This data is required while defining or editing a policy plan.</p>
planCode	<p>Used to specify the plan number.</p> <p><b>Note:</b> The value is stored as a characteristic on the price item. The system stores the value against the characteristic type which is specified in the <b>Plan Code Characteristic Type</b> parameter of the <b>C1-CINMSGPRC</b> algorithm.</p>	<p>Yes (Conditional)</p> <p><b>Note:</b> This data is required while defining or editing a policy plan.</p>
coverageType	<p>Used to specify the coverage type.</p> <p><b>Note:</b> The value is stored as a characteristic on the price item. The system stores the value against the characteristic type which is specified in the <b>Coverage Type Characteristic Type</b> parameter of the <b>C1-CINMSGPRC</b> algorithm.</p>	<p>No</p>
productCode	<p>Used to indicate the product to which the price item is mapped.</p> <p><b>Note:</b> The value is stored as a characteristic on the price item. The system stores the value against the characteristic type which is specified in the <b>Product Characteristic Type</b> parameter of the <b>C1-CINMSGPRC</b> algorithm.</p>	<p>No</p>

Tag Name	Tag Description	Mandatory (Yes or No)
rateCoverageType	<p>Used to specify the contract type using which the contract should be created for the policy plan. The system checks whether a price item already exists where the specified rate coverage type, coverage type, and plan code are defined on the price item as characteristics. If a price item exists with these characteristics, the system maps the price item to the policy plan. However, if a price item does not exist with these characteristics, the system create a new price item, concatenates the rate coverage type and plan code to generate the price item code, and then maps the price item to the policy plan.</p> <p><b>Note:</b> You must specify a value which is already defined in the <b>RATE_COVRG_CNTRACT_TYPE</b> lookup field. It must be in the <b>Active</b> status.</p> <p>The value is stored as a characteristic on the price item. The system stores the value against the characteristic type which is specified in the <b>Rate Coverage Type Characteristic Type</b> parameter of the <b>C1-CINMSGPRC</b> algorithm.</p> <p>A new price item is created using the business object which is specified in the <b>Price Item Business Object</b> parameter of the <b>C1-CINMSGPRC</b> algorithm.</p>	<p>Yes (Conditional)</p> <p><b>Note:</b> This data is required while defining or editing a policy plan.</p>
planEffectiveDate	<p>Used to specify the date from when the policy plan is effective.</p> <p><b>Note:</b> The value is also stored as a characteristic on the policy plan. The system stores the value against the characteristic type which is specified in the <b>Plan Effective Date Characteristic Type</b> parameter of the <b>C1-CINMSGPRC</b> algorithm.</p> <p>The policy plan start date cannot be later than the policy plan end date.</p> <p>The policy plan start date cannot be earlier than the policy start date or later than the policy end date.</p>	<p>Yes (Conditional)</p> <p><b>Note:</b> This data is required while defining a policy plan.</p>
planEndDate	<p>Used to specify the date till when the policy plan is effective.</p> <p><b>Note:</b> The policy plan end date cannot be earlier than the policy plan start date.</p> <p>The policy plan end date cannot be earlier than the policy start date or later than the policy end date.</p>	<p>Yes (Conditional)</p> <p><b>Note:</b> This data is required while defining a policy plan.</p>

Tag Name	Tag Description	Mandatory (Yes or No)
planActivityDate	Used to specify the date when the activity is scheduled for the policy plan.  <b>Note:</b> The value is stored as a characteristic on the policy plan. The system stores the value against the characteristic type which is specified in the <b>Plan Activity Date Characteristic Type</b> parameter of the <b>C1-CINMSGPRC</b> algorithm.	No

The following table lists and describes the tags which are available in the customer inbound message schema, but should not be included in the XML file:

Tag Name	Tag Description						
c1InboundMessage	Displays the inbound message ID.						
boStatus	Displays the status of the customer inbound message.						
statusReason	Indicates the reason why the status of the customer inbound message is changed.						
c1ExternalTransactionId	Indicates the transaction in the external source system which resulted in the customer inbound message.						
c1ExternalBatchId	Indicates the external batch job or batch run number through which the customer inbound message is created.						
c1ExternalSourceId	Displays the external source system ID.						
person	At present, this tag is not supported in a customer inbound message.						
statusDateTime	Displays the date and time when the status of the customer inbound message is changed in the system.						
creationDateTime	Displays the date and time when the customer inbound message is created in the system.						
version	This tag appears within the following parent tags: <table border="1" data-bbox="646 1325 1463 1604"> <thead> <tr> <th>Parent Tag</th> <th>Then the purpose of the version tag is...</th> </tr> </thead> <tbody> <tr> <td>schema</td> <td>Displays the version of the customer inbound message.</td> </tr> <tr> <td>inboundMessageCharacteristic</td> <td>Displays the version of the characteristic defined for the customer inbound message.</td> </tr> </tbody> </table>	Parent Tag	Then the purpose of the version tag is...	schema	Displays the version of the customer inbound message.	inboundMessageCharacteristic	Displays the version of the characteristic defined for the customer inbound message.
Parent Tag	Then the purpose of the version tag is...						
schema	Displays the version of the customer inbound message.						
inboundMessageCharacteristic	Displays the version of the characteristic defined for the customer inbound message.						
searchCharacteristicValue	At present, this tag is not supported in a customer inbound message.						
messageID	Displays the inbound message ID.						
status	Displays the status of the customer inbound message.						
createDateTime	Displays the date and time when the customer inbound message is created in the system.						
ORMBcreateDateTime	Displays the date and time when the customer inbound message is created in the system.						

Tag Name	Tag Description
policyStatus	<p>Indicates the status of the policy. The valid values are:</p> <ul style="list-style-type: none"> <li>• In Force/Active</li> <li>• Pending Cancellation</li> <li>• Canceled</li> <li>• Pending Reinstatement</li> <li>• Reinstated</li> <li>• Pending Termination</li> <li>• Terminated</li> </ul>
toDoRetry	<p>Displays the information about the retry option used for the customer inbound message.</p> <div style="border: 1px solid black; padding: 5px;"> <p><b>Note:</b> This information appears at the bottom of the inbound message in the <b>Inbound Message Content</b> zone once the customer inbound message is validated and processed either through the user interface or batch process.</p> </div>
retryDateTime	Displays the date and time when the retry option is used to change the status of the customer inbound message from <b>Rejected</b> to <b>Pending</b> .
numberOfRetries	Indicates the number of times the retry option is used for the customer inbound message.
currentErrorState	<p>Indicates the status to which the customer inbound message is transitioned when its validation or processing fails. The valid value is:</p> <ul style="list-style-type: none"> <li>• REJECTED</li> </ul>
isRetried	<p>Indicates whether the retry option is used to change the status of the customer inbound message. The valid values are:</p> <ul style="list-style-type: none"> <li>• true</li> <li>• false</li> </ul>

### **Related Topics**

For more information on...	See...
Customer Inbound Message Schema	<a href="#">Customer Inbound Message Schema</a> on page 1790
Sample Customer Inbound Message	<a href="#">Sample Customer Inbound Message</a> on page 1793
How to setup the <b>C1-BILLCYCLE</b> feature configuration	<a href="#">Setting the C1-BILLCYCLE Feature Configuration</a> on page 2905

## **Customer Inbound Message Schema**

```
<schema>
  <c1InboundMessage></c1InboundMessage>
  <messageType></messageType>
  <bo></bo>
  <boStatus></boStatus>
  <statusReason></statusReason>
  <sourceSystem></sourceSystem>
  <c1ExternalTransactionId></c1ExternalTransactionId>
```

```

<clExternalBatchId></clExternalBatchId>
<clExternalSourceId></clExternalSourceId>
<person></person>
<statusDateTime></statusDateTime>
<creationDateTime></creationDateTime>
<version></version>
<characteristics>
  <inboundMessageCharacteristic>
    <adhocCharacteristicValue></adhocCharacteristicValue>
    <characteristicType></characteristicType>
    <effectiveDate></effectiveDate>
    <characteristicValue></characteristicValue>
    <characteristicValueForeignKey1></characteristicValueForeignKey1>
    <characteristicValueFK2></characteristicValueFK2>
    <characteristicValueFK3></characteristicValueFK3>
    <characteristicValueFk4></characteristicValueFk4>
    <characteristicValueFK5></characteristicValueFK5>
    <searchCharacteristicValue></searchCharacteristicValue>
    <version></version>
  </inboundMessageCharacteristic>
</characteristics>
<customerStructureMessage>
  <headerData>
    <messageType></messageType>
    <messageID></messageID>
    <messageBatchID></messageBatchID>
    <sourceSystem></sourceSystem>
    <sourceSystemTransID></sourceSystemTransID>
    <sourceSystemSourceID></sourceSystemSourceID>
    <bo></bo>
    <status></status>
    <createDateTime></createDateTime>
    <ORMBcreateDateTime></ORMBcreateDateTime>
    <transactionType></transactionType>
    <externalTransactionType></externalTransactionType>
  </headerData>
  <customerStructureData>
    <customerData>
      <customerName></customerName>
      <customerType></customerType>
      <Id>
        <IDType></IDType>
        <IDValue></IDValue>
        <isPrimary></isPrimary>
      </Id>
      <parentSection>
        <IDType></IDType>
        <IDValue></IDValue>
        <relationshipType></relationshipType>
        <isFranchiseBillingIndicator></
isFranchiseBillingIndicator>
      </parentSection>
      <characteristics>
        <characteristicsList>
          <characteristicType></characteristicType>
          <characteristicValue></characteristicValue>
          <effectiveDate></effectiveDate>
        </characteristicsList>
      </characteristics>
      <address>
        <addressEffDate></addressEffDate>
        <addressType></addressType>
        <MailingName></MailingName>
        <address1></address1>

```

```

        <address2></address2>
        <address3></address3>
        <city></city>
        <state></state>
        <zip></zip>
        <country></country>
        <attentionName></attentionName>
    </address>
    <email></email>
    <phones>
        <phoneType></phoneType>
        <phoneValue></phoneValue>
    </phones>
</customerData>
<billGroup>
    <customerClass></customerClass>
    <billCycle></billCycle>
    <division></division>
    <billRouteType></billRouteType>
    <billGroupID></billGroupID>
    <bankNumber></bankNumber>
    <depositoryFinancialInstitution></
depositoryFinancialInstitution>
    <accountType></accountType>
    <billAddressSource></billAddressSource>
    <Id>
        <IDType></IDType>
        <IDValue></IDValue>
        <isPrimary></isPrimary>
    </Id>
    <address>
        <addressEffDate></addressEffDate>
        <billToName></billToName>
        <address1></address1>
        <address2></address2>
        <address3></address3>
        <city></city>
        <state></state>
        <zip></zip>
        <country></country>
        <attentionName></attentionName>
    </address>
    <characteristics>
        <characteristicsList>
            <characteristicType></characteristicType>
            <characteristicValue></characteristicValue>
            <effectiveDate></effectiveDate>
        </characteristicsList>
    </characteristics>
    <phones>
        <phoneType></phoneType>
        <phoneValue></phoneValue>
    </phones>
    <email></email>
</billGroup>
<policyData>
    <policyNumber></policyNumber>
    <sourceSystem></sourceSystem>
    <endDate></endDate>
    <renewalDate></renewalDate>
    <policyName></policyName>
    <terminateDate></terminateDate>
    <policyStatus></policyStatus>
    <statusReason></statusReason>

```



```

    <policyEffectiveDate></policyEffectiveDate>
    <characteristics>
      <characteristicsList>
        <characteristicType></characteristicType>
        <characteristicValue></characteristicValue>
        <effectiveDate></effectiveDate>
      </characteristicsList>
    </characteristics>
    <packageSavings>
      <packageSavings></packageSavings>
      <startDate></startDate>
      <endDate></endDate>
      <nonintegratedInd></nonintegratedInd>
    </packageSavings>
    <plan>
      <planCode></planCode>
      <coverageType></coverageType>
      <productCode></productCode>
      <rateCoverageType></rateCoverageType>
      <planEffectiveDate></planEffectiveDate>
      <planEndDate></planEndDate>
      <planActivityDate></planActivityDate>
      <rateEffectiveDate></rateEffectiveDate>
      <rateActivityDate></rateActivityDate>
      <characteristics>
        <characteristicsList>
          <characteristicType></characteristicType>
          <characteristicValue></characteristicValue>
          <effectiveDate></effectiveDate>
        </characteristicsList>
      </characteristics>
    </plan>
  </policyData>
</customerStructureData>
</customerStructureMessage>
<toDoRetry>
  <retryDateTime></retryDateTime>
  <numberOfRetries></numberOfRetries>
  <currentErrorState></currentErrorState>
  <isRetried></isRetried>
</toDoRetry>
</schema>

```

## Sample Customer Inbound Message

Using the below example, you can do the following:

- Create the customer and bill groups (i.e. accounts) for a fully-insured health care business
- Create a fully-insured policy along with package savings and policy plan

Customer	Bill Group (i.e. Account)	Policy	Policy Plan
Williams, Tom	126535	WT1256678	HCBILLING1

```

<schema>
  <characteristics>
    <inboundMessageCharacteristic>
      <adhocCharacteristicValue></adhocCharacteristicValue>
      <characteristicType>C1-EXTBTCT</characteristicType>
      <effectiveDate>2017-01-01</effectiveDate>
      <characteristicValue>DATAEXT11</characteristicValue>
      <characteristicValueForeignKey1></characteristicValueForeignKey1>
      <characteristicValueFK2></characteristicValueFK2>
    </inboundMessageCharacteristic>
  </characteristics>
</schema>

```

```

        <characteristicValueFK3></characteristicValueFK3>
        <characteristicValueFK4></characteristicValueFK4>
        <characteristicValueFK5></characteristicValueFK5>
    </inboundMessageCharacteristic>
</characteristics>
<customerStructureMessage>
    <headerData>
        <messageType>C1-CUSTOMER-INB-MSG-TYPE</messageType>
        <messageBatchID>211</messageBatchID>
        <sourceSystem>SMALLPRIME</sourceSystem>
        <sourceSystemTransID>01P200</sourceSystemTransID>
        <sourceSystemSourceID>00100</sourceSystemSourceID>
        <bo>C1-CustomerInboundMessage</bo>
        <transactionType>NEW</transactionType>
        <externalTransactionType>NEW</externalTransactionType>
    </headerData>
    <customerStructureData>
        <customerData>
            <customerName>Williams, Tom</customerName>
            <customerType>B</customerType>
            <parentSection>
                <IDType>SSN</IDType>
                <IDValue>987-65-4320</IDValue>
                <relationshipType>BILLING</relationshipType>
                <isFranchiseBillingIndicator>Y</
isFranchiseBillingIndicator>
            </parentSection>
            <characteristics>
                <characteristicsList>
                    <characteristicType>C1FRANCD</characteristicType>
                    <characteristicValue>123</characteristicValue>
                </characteristicsList>
            </characteristics>
            <email>williams.tom@example.com</email>
            <Id>
                <IDType>SSN</IDType>
                <IDValue>987-65-4321</IDValue>
                <isPrimary>Y</isPrimary>
            </Id>
            <address>
                <addressEffDate>2017-01-01</addressEffDate>
                <addressType>MAIN</addressType>
                <MailingName>Tom</MailingName>
                <address1>Apartment 213</address1>
                <address2>Rockaway Valley Road</address2>
                <city>Boonton</city>
                <state>NJ</state>
                <zip>07005</zip>
                <country>USA</country>
                <attentionName>Near Canterbury Road Junction</
attentionName>
            </address>
            <phones>
                <phoneType>BUSN</phoneType>
                <phoneValue>(862) 555-0145</phoneValue>
            </phones>
            <phones>
                <phoneType>FAX</phoneType>
                <phoneValue>(862) 555-0100</phoneValue>
            </phones>
        </customerData>
        <billGroup>
            <customerClass>HC</customerClass>
            <billCycle>INM1</billCycle>
        </billGroup>
    </customerStructureData>
</customerStructureMessage>

```

```

<division>930</division>
<billRouteType>POSTAL</billRouteType>
<billGroupID>126535</billGroupID>
<billAddressSource>PER</billAddressSource>
<characteristics>
  <characteristicsList>
    <characteristicType>C1INVHLD</characteristicType>
    <characteristicValue>CMDR</characteristicValue>
  </characteristicsList>
  <characteristicsList>
    <characteristicType>C1OFFRST</characteristicType>
    <characteristicValue>1</characteristicValue>
  </characteristicsList>
</characteristics>
<phones>
  <phoneType>FAX</phoneType>
  <phoneValue>(862) 555-0123</phoneValue>
</phones>
<email>williams.tom@example123.com</email>
</billGroup>
<policyData>
  <policyNumber>WT1256678</policyNumber>
  <sourceSystem>SMALLPRIME</sourceSystem>
  <endDate>2017-12-31</endDate>
  <policyName>Medicare Policy</policyName>
  <policyEffectiveDate>2017-01-01</policyEffectiveDate>
  <characteristics>
    <characteristicsList>
      <characteristicType>C1PRBASE</characteristicType>
      <characteristicValue>Y</characteristicValue>
      <effectiveDate>2017-01-01</effectiveDate>
    </characteristicsList>
    <characteristicsList>
      <characteristicType>C1PRTNRL</characteristicType>
      <characteristicValue>D</characteristicValue>
      <effectiveDate>2017-01-01</effectiveDate>
    </characteristicsList>
    <characteristicsList>
      <characteristicType>C1STISSE</characteristicType>
      <characteristicValue>NJ</characteristicValue>
    </characteristicsList>
  </characteristics>
  <packageSavings>
    <packageSavings>XXD01</packageSavings>
    <startDate>2017-01-01</startDate>
    <endDate>2017-02-28</endDate>
  </packageSavings>
  <plan>
    <planCode>HCBILLING1</planCode>
    <coverageType>CMB</coverageType>
    <productCode>PS1</productCode>
    <rateCoverageType>CMM</rateCoverageType>
    <planEffectiveDate>2017-01-01</planEffectiveDate>
    <planEndDate>2017-12-31</planEndDate>
    <planActivityDate>2017-01-01</planActivityDate>
    <characteristics>
      <characteristicsList>
        <characteristicType>C1CHRGLN</characteristicType>
        <characteristicValue>CASH</characteristicValue>
      </characteristicsList>
      <characteristicsList>
        <characteristicType>C1PLDESC</characteristicType>
        <characteristicValue>CHOICE+INS</
characteristicValue>

```

```

        </characteristicsList>
      </characteristics>
    </plan>
  </policyData>
</customerStructureData>
</customerStructureMessage>
</schema>

```

## Membership Inbound Message

---

On calling the **C1-MembershipInboundMessage** web service, a membership inbound message is created in the **Pending** status. When the **Membership Inbound Message Periodic Monitor (C1-MEMIN)** batch is invoked, the system checks whether there are any membership inbound messages in the **Pending** status. If there is a membership inbound message in the **Pending** status, the system validates the membership inbound message. If a membership inbound message is successfully validated, it is processed further and the following entities are created or updated in the system based on the available information in the membership inbound message:

- Membership
- Main Subscriber
- Dependent Person
- Billable Charge (for membership premium)

In addition, the system enables you to submit the membership inbound messages for validation and processing from the user interface. On submitting a membership inbound message, the system validates the membership inbound message. If a membership inbound message is successfully validated, it is processed further and the required entities are created or updated in the system based on the available information.

Once all required entities are created or updated in the system, the status of the membership inbound message is changed to **Processed**. If any error occurs while validating or processing a membership inbound message, the status of the membership inbound message is changed to **Rejected**. The system enables you to either reprocess or void a rejected membership inbound message. The system can reprocess a membership inbound message only when its status is changed to **Pending**. Using the **Retry** option, you can change the status of the membership inbound message from **Rejected** to **Pending**. The **Membership Inbound Message Periodic Monitor (C1-MEMIN)** batch will then reconsider the membership inbound message for validation and processing.

You can also configure the system such that the batch can automatically retry to process the rejected membership inbound messages. However, it will attempt to retry only when the **Maximum Retry** parameter in the **Retry for To Dos (C1-TODORETRY)** algorithm is set to a value greater than zero. Also, the maximum number of times the batch can attempt to retry and reprocess a membership inbound message depends on the value defined in the **Maximum Retry** parameter.

### Prerequisites

To use the membership inbound message feature, you need to do the following:

- Define the required membership inbound message types in the system.
- Define the required characteristic types where the characteristic entity is set to **Inbound Message Type**.
- Define the required characteristic types where the characteristic entity is set to **Inbound Message**.
- Define values for the required parameters in the **C1-INMEMEVAL**, **C1-INMEMEPRC**, **C1-TODORETRY**, and **C1-TDCRINMSG** algorithms.
- Define the **Membership BO (C1MEMBRO)** characteristic for the policy type which is specified in the **C1-CINMSGPRC** algorithm.
- Define predefined values for the **C1RATCOV**, **C1TRNCAT**, **C1INAPPC**, **C1CVTIER**, and **C1PRODTY** characteristic types.

- Define values for the **C1-SourceSystemLookup** extendable lookup.
- Define values for the **PER\_OR\_BUS\_FLG**, **ADDRESS\_TYPE\_FLG**, and **RATE\_COVRG\_CNTRACT\_TYPE** lookup fields.
- Define the required person identifier types, account identifier types, characteristic types, phone types, service quantity identifiers, and contract relationship types in the application.
- Define values for the **C1\_INVOICE\_DAY\_BILL\_PERIOD\_FLG** lookup field.

**Note:** Each lookup field value should be mapped to a valid bill period which exists in the system. You must then define this lookup field value as a predefined value for the **C1OFFRST** characteristic type. The system will then use the bill period configured for the respective invoice day when the **C1OFFRST** characteristic is defined for the account.

- Define predefined values for the **C1OFFRST** characteristic type.
- Set the batch control type of the **Membership Inbound Message Periodic Monitor (C1-MEMIN)** batch to **Timed** and define the following attributes:
  - Time Interval
  - Timer Active
  - User ID
  - Batch Language
  - Email Address
- Define bill cancel reasons which you want to use on premium bill segment cancelation during the membership termination.

## Membership Inbound Message Status Transition through User Interface

The following figure graphically indicates how a membership inbound message moves from one status to another when it is validated and processed through the user interface:

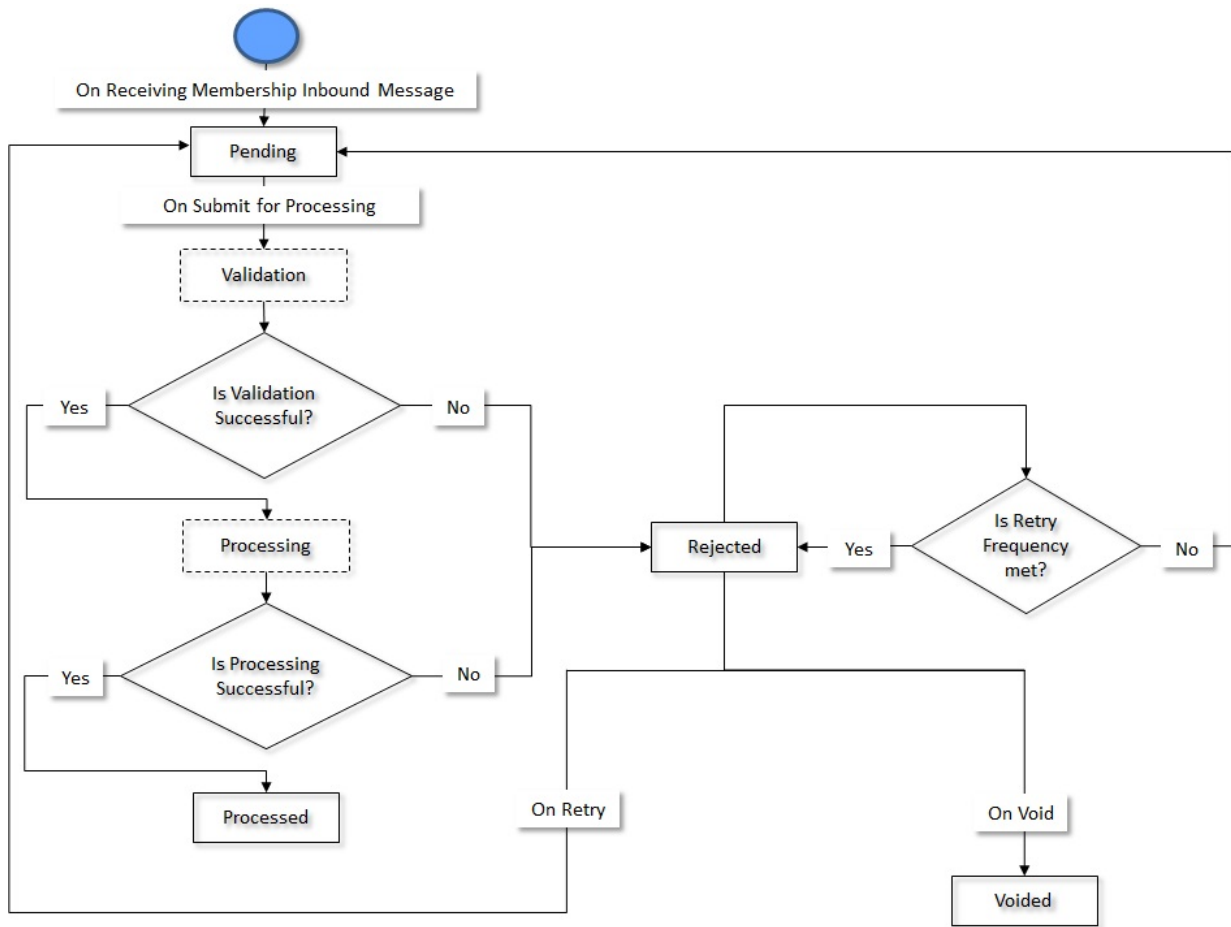

### Membership Inbound Message Status Transition through a Batch Process

The following figure graphically indicates how a membership inbound message moves from one status to another when it is validated and processed through the **Membership Inbound Message Periodic Monitor (C1-MEMIN)** batch:

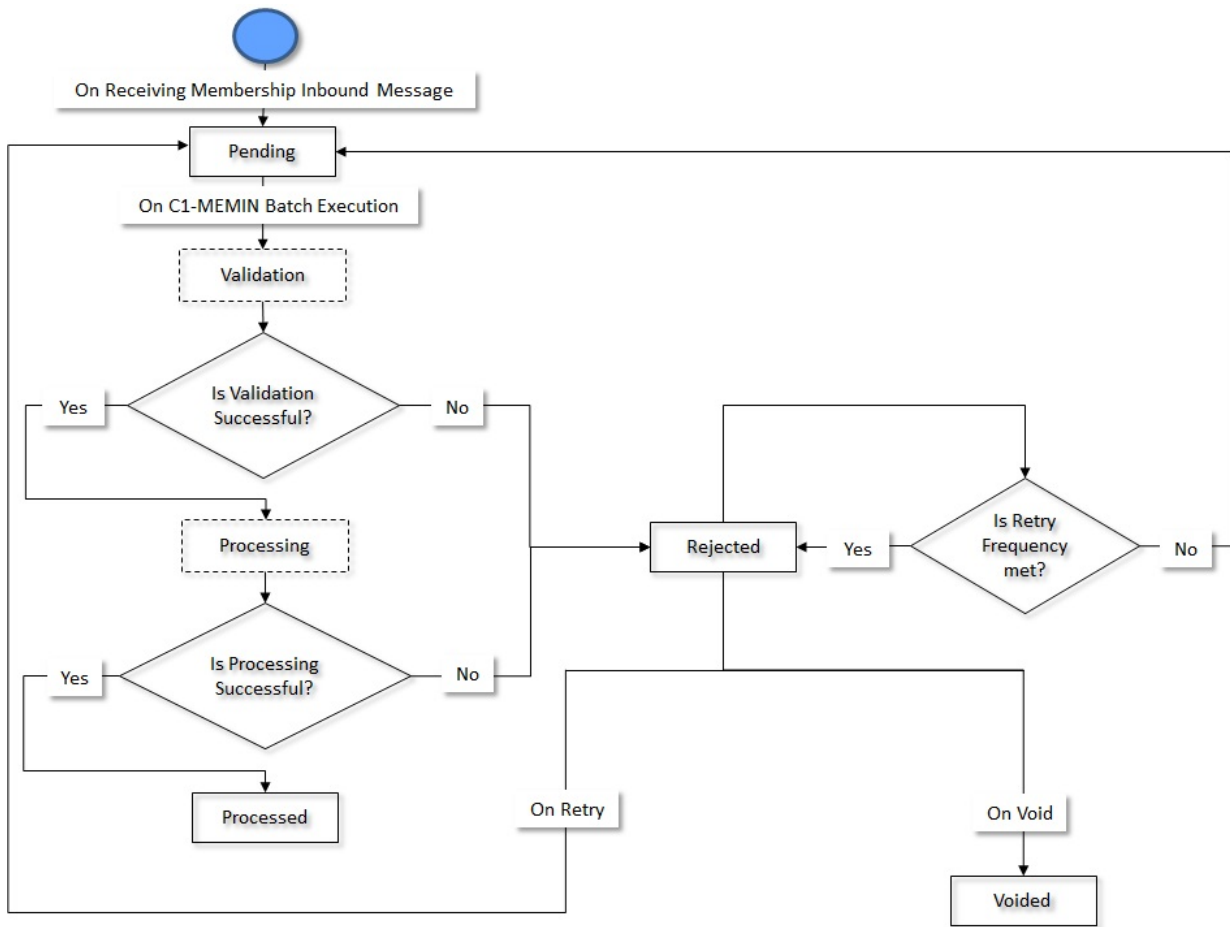

## Algorithms Used in C1-MemberInboundMessage

The following table lists the algorithms which are used in the lifecycle of the **C1-MemberInboundMessage** business object:

Status	System Event	Algorithm	Algorithm Type	Description
Pending	Monitor	C1-AT-RQJ	C1-GEN-BOMNJ	Refer to <a href="#">C1-AT-RQJ</a> on page 1762.
Validation	Monitor	F1-AT-RQJ	F1-GEN-BOMNJ	Refer to <a href="#">F1-AT-RQJ</a> on page 1257.
	Enter	C1-INMEMEVAL	C1-INMEMEVAL	Refer to <a href="#">C1-INMEMEVAL</a> on page 1800.
Processing	Monitor	F1-AT-RQJ	F1-GEN-BOMNJ	Refer to <a href="#">F1-AT-RQJ</a> on page 1257.
	Enter	C1-INMEMEPRC	C1-INMEMEPRC	Refer to <a href="#">C1-INMEMEPRC</a> on page 1801.
Rejected	Monitor	C1-TODORETRY	C1-TODORETRY	Refer to <a href="#">C1-TODORETRY</a> on page 1772.

Status	System Event	Algorithm	Algorithm Type	Description
	Enter	C1-TDCRINMSG	F1-TDCREATE	Refer to <a href="#">C1-TDCRINMSG</a> on page 1772.
	Exit	F1-TODOCOMPL	F1-TODOCOMPL	Refer to <a href="#">F1-TODOCOMPL</a> on page 1256.
Processed	-	-	-	-
Voided	-	-	-	-

### C1-AT-RQJ

This algorithm is invoked when the status of the customer or membership inbound message is changed to **Pending**. If the **isRetried** flag in the inbound message is set to **true**, it resets the flag to **false**.

It contains the following parameters:

- **Next Status** – Used when you want to override the default next status specified in the lifecycle.
- **Next Transition Condition** – Used when you want to override the default next transition condition specified in the lifecycle.

**Note:** At a time, you can specify value for either the **Next Status** or **Next Transition Condition** parameter. If you don't specify any value for these parameters, the system will transition the business object to the default next status specified in its lifecycle.

### F1-AT-RQJ

This algorithm transitions the current status of the business object to the specified status. It contains the following parameters:

- **Next Status** – Used when you want to override the default next status specified in the lifecycle.
- **Next Transition Condition** – Used when you want to override the default next transition condition specified in the lifecycle.

At a time, you can specify value for either the **Next Status** or **Next Transition Condition** parameter. If you don't specify any value for these parameters, the system will transition the business object to the default next status specified in its lifecycle.

### C1-INMEMEVAL

This algorithm is invoked when the **Membership Inbound Message Periodic Monitor (C1-MEMIN)** batch is executed and when you click the **Submit for Processing** button. It validates the membership inbound message which is in the **Pending** status. It checks the following:

- Whether the primary identifier is specified for the person.
- Whether the policy with the specified policy number and source system combination exists in the system.
- Whether the policy plan exists in the policy.
- Whether the bill group ID (i.e. account identifier) is specified in the member plan coverage information.
- Whether the **Plan Code** characteristic type (as mentioned in the **Plan Code Characteristic Type** parameter) exists in the member plan coverage information.
- Whether the **Rate Coverage Type** characteristic type (as mentioned in the **Rate Coverage Type Characteristic Type** parameter) exists in the member plan coverage information and a valid value is specified for this characteristic type.



If any of the above validation fails, the status of the membership inbound message is changed to **Rejected**. In addition, the appropriate log entry is added which you can view in the **Inbound Message Log** zone.

This algorithm contains the following parameters:

Parameter	Description	Mandatory (Yes or No)
Next Status	Used when you want to override the default next status specified in the lifecycle.	No
Next Transition Condition	Used when you want to override the default next transition condition specified in the lifecycle.	No
Plan Code Characteristic Type	Used to specify the characteristic type which you want to use to store the policy plan number. This type of characteristic is defined on the price item. The system uses this characteristic to derive the price item.  <b>Note:</b> By default, the parameter value is set to <b>C1HPLNID</b> . You can change the characteristic type, if required. However, you must specify a characteristic type where the characteristic entity is set to <b>Price Item</b> .	Yes
Rate Coverage Type Characteristic Type	Used to specify the characteristic type which you want to use to store the rate coverage type. This type of characteristic is defined on the price item. The system uses this characteristic to derive the price item.  <b>Note:</b> By default, the parameter value is set to <b>C1RATCOV</b> . You can change the characteristic type, if required. However, you must specify a characteristic type where the characteristic entity is set to <b>Price Item</b> .	Yes
Account Identifier Type	Used to indicate the account identifier type. The system derives the account using the account identifier type and account identifier combination.  <b>Note:</b> By default, the parameter value is set to <b>C1_F_ANO</b> . You can change the parameter value, if required. However, you must specify an account identifier type which is already defined in the system.	No

### C1-INMEMEPRC

This algorithm is invoked once a membership inbound message is successfully validated. It processes the membership inbound message and accordingly does the following:

- Adds or updates a membership in a policy plan
- Adds a dependent in a membership
- Updates the details of the main subscriber or dependent person
- Creates main subscriber or dependent person

- Associates a contract with a membership
- Creates a membership premium billable charge for a coverage period

If the processing fails due to any reason, the status of the membership inbound message is changed to **Rejected**. In addition, the appropriate log entry is added which you can view in the **Inbound Message Log** zone.

This algorithm contains the following parameters:

Parameter	Description	Mandatory (Yes or No)
Next Status	Used when you want to override the default next status specified in the lifecycle.	No
Next Transition Condition	Used when you want to override the default next transition condition specified in the lifecycle.	No
Subscriber Member Business Object	Used to specify the business object using which you want to create the main subscriber or dependent person in the system.  <b>Note:</b> By default, the parameter value is set to <b>C1-HCCustomer</b> . You can change the parameter value, if required. However, you must specify a business object which is already defined in the system.	No
Description on Bill	Used to specify the description that you want to display on the premium billable charge.  <b>Note:</b> By default, the parameter value is set to <b>Premium</b> .	No
Premium Amount Service Quantity Identifier	Used to indicate the service quantity identifier (SQI) against which you want to store the premium amount. The system uses this SQI while creating the premium billable charges.  <b>Note:</b> By default, the parameter value is set to <b>PREMAMT</b> . You can change the parameter value, if required. However, you must specify a service quantity identifier which is already defined in the system.	No
Recurring Flag	Used to indicate that you want to create recurring bill segments at the intervals defined in the bill period.  <b>Note:</b> By default, the parameter value is set to <b>BP</b> .	No

Parameter	Description	Mandatory (Yes or No)
Plan Code Characteristic Type	<p>Used to specify the characteristic type which you want to use to store the policy plan number. This type of characteristic is defined on the price item. The system uses this characteristic to derive the price item.</p> <p><b>Note:</b> By default, the parameter value is set to <b>C1HPLNID</b>. You can change the characteristic type, if required. However, you must specify a characteristic type where the characteristic entity is set to <b>Price Item</b>.</p>	Yes
Rate Coverage Type Characteristic Type	<p>Used to specify the characteristic type which you want to use to store the rate coverage type. This type of characteristic is defined on the price item. The system uses this characteristic to derive the price item.</p> <p><b>Note:</b> By default, the parameter value is set to <b>C1RATCOV</b>. You can change the characteristic type, if required. However, you must specify a characteristic type where the characteristic entity is set to <b>Price Item</b>.</p>	Yes
Policy Plan Characteristic Type	<p>Used to specify the characteristic type which you want to use to store the policy plan ID. This type of characteristic is defined on the contract. The system uses this characteristic to derive the active contract associated with the memberships of the policy plan.</p> <p><b>Note:</b> By default, the parameter value is set to <b>C1POLPLN</b>. You can change the characteristic type, if required. However, you must specify a characteristic type where the characteristic entity is set to <b>Contract</b>.</p>	Yes

Parameter	Description	Mandatory (Yes or No)
Main Subscriber Characteristic Type	<p>Used to specify the characteristic type which you want to use to indicate whether the person is the main subscriber in a membership. This type of characteristic is defined on the person. The system checks whether the value for this characteristic (specified in the membership inbound message) matches the value specified in the <b>Main Subscriber Characteristic Value</b> parameter. If so, it considers the person as the main subscriber. Otherwise, the person is considered as a dependent person.</p> <p><b>Note:</b> By default, the parameter value is set to <b>C1DEPCD</b>. You can change the characteristic type, if required. However, you must specify a characteristic type where the characteristic entity is set to <b>Person</b>.</p>	Yes
Main Subscriber Characteristic Value	<p>Used to specify the value for the characteristic type which is specified in the <b>Main Subscriber Characteristic Type</b> parameter.</p> <p><b>Note:</b> By default, the parameter value is set to <b>MEM</b>.</p>	No
Account Identifier Type	<p>Used to indicate the account identifier type. The system derives the account using the account identifier type and account identifier combination.</p> <p><b>Note:</b> By default, the parameter value is set to <b>C1_F_ANO</b>. You can change the parameter value, if required. However, you must specify an account identifier type which is already defined in the system.</p>	No
Bill Segment Cancel Reason	<p>Used to indicate the cancel reason which you want to use during premium bill segment cancelation on the membership termination.</p> <p><b>Note:</b> By default, the parameter value is set to <b>MASS</b>. You can change the parameter value, if required. However, you must specify a bill cancel reason which is already defined in the system.</p>	No

Parameter	Description	Mandatory (Yes or No)
Invoice Day Characteristic Type	<p>Used to specify the characteristic type which you want to use to store the invoice day for the account. This type of characteristic is defined on the account. The system fetches the bill period mapped to the invoice day in the <b>C1_INVOICE_DAY_BILL_PERIOD_FLG</b> lookup field while creating premium billable charges for accounts.</p> <p><b>Note:</b> By default, the parameter value is set to <b>C1OFFRST</b>. You can change the characteristic type, if required. However, you must specify a characteristic type where the characteristic entity is set to <b>Account</b>.</p>	Yes
Membership Characteristic Type	<p>Used to specify the characteristic type which you want to use to store the membership ID. This type of characteristic is defined on the billable charge. The system uses this characteristic to derive premium billable charges whose corresponding bill segments must be canceled due to change in membership coverage period.</p> <p><b>Note:</b> By default, the parameter value is set to <b>CIMMBRSH</b>. You can change the characteristic type, if required. However, you must specify a characteristic type where the characteristic entity is set to <b>Billable Charge</b>.</p>	Yes
Membership Business Object Characteristic Type	<p>Used to specify the characteristic type which you want to use to store the business object using which the membership must be created. This type of characteristic is defined on the policy type.</p> <p><b>Note:</b> By default, the parameter value is set to <b>CIMEMBRO</b>. You can change the characteristic type, if required. However, you must specify a characteristic type where the characteristic entity is set to <b>Policy Type</b>.</p>	Yes

Parameter	Description	Mandatory (Yes or No)
Transaction Type Category Characteristic Type	<p>Used to specify the characteristic type which you want to use to indicate the type of the transaction (i.e. whether the transaction is related to premium, fee, and so on). This type of characteristic is defined on the billable charge. The system uses this characteristic to derive premium billable charges.</p> <p><b>Note:</b> By default, the parameter value is set to <b>C1TRNCAT</b>. You can change the characteristic type, if required. However, you must specify a characteristic type where the characteristic entity is set to <b>Billable Charge</b>.</p>	Yes
Transaction Type Category Characteristic Value	<p>Used to specify the value for the characteristic type which is specified in the <b>Transaction Type Category Characteristic Type</b> parameter.</p> <p><b>Note:</b> By default, the parameter value is set to <b>CMPREM</b>.</p>	No
Inactive Policy Plan Characteristic Type	<p>Used to specify the characteristic type which you want to use to indicate whether the policy plan is inactive. This type of characteristic is defined on the contract. The system uses this characteristic to derive contracts associated with the memberships of policy plan .</p> <p><b>Note:</b> By default, the parameter value is set to <b>C1INAPPC</b>. You can change the characteristic type, if required. However, you must specify a characteristic type where the characteristic entity is set to <b>Contract</b>.</p>	Yes
Coverage Tier Characteristic Type	<p>Used to specify the characteristic type which you want to use to indicate the coverage tier to which the membership belongs. This type of characteristic is defined on the membership.</p> <p><b>Note:</b> By default, the parameter value is set to <b>C1CVTIER</b>. You can change the characteristic type, if required. However, you must specify a characteristic type where the characteristic entity is set to <b>Membership</b>.</p>	Yes

Parameter	Description	Mandatory (Yes or No)
Membership Termination Status	<p>Used to indicate the status to which you want to transition the membership when the membership is terminated.</p> <p><b>Note:</b> By default, the parameter value is set to <b>TERMINATE</b>. You can change the parameter value, if required. However, you must specify a status which is already defined in the lifecycle of the <b>C1-Membership</b> business object.</p>	No
Medical Rate Coverage Type	<p>Used to specify a medical contract type. The system evaluates whether the rate coverage type specified in the membership inbound message is a medical contract type using this parameter value.</p> <p><b>Note:</b> By default, the parameter value is set to <b>M</b>. You can change the parameter value, if required. However, you must specify a value which is already defined in the <b>RATE_COVRG_CNTRACT_TYPE</b> lookup field.</p>	No
Policy Characteristic Type	<p>Used to specify the characteristic type which you want to use to store the policy ID. This type of characteristic is defined on the billable charge. The system uses this characteristic to derive the packaged savings billable charge when the membership coverage period is changed.</p> <p><b>Note:</b> By default, the parameter value is set to <b>C1POLICY</b>. You can change the characteristic type, if required. However, you must specify a characteristic type where the characteristic entity is set to <b>Billable Charge</b>.</p>	Yes
Product Type Characteristic Type	<p>Used to specify the characteristic type which you want to use to indicate the type of the product. This type of characteristic is defined on the price item. The system uses this characteristic to derive packaged savings billable charges whose corresponding bill segments must be canceled due to change in membership coverage period.</p> <p><b>Note:</b> By default, the parameter value is set to <b>C1PRODTY</b>. You can change the characteristic type, if required. However, you must specify a characteristic type where the characteristic entity is set to <b>Price Item</b>.</p>	Yes

Parameter	Description	Mandatory (Yes or No)
Product Type Characteristic Value	Used to specify the value for the characteristic type which is specified in the <b>Product Type Characteristic Type</b> parameter.  <b>Note:</b> By default, the parameter value is set to <b>PACKSAV</b> .	No
Policy Status	Used to specify the status of the policy. If the parameter value is specified and if the parameter value matches the policy status, the system validates whether the membership start and end dates fall within the policy plan start and end dates.  <b>Note:</b> You must specify a status which is already defined in the lifecycle of the <b>C1-Policy</b> business object.	No
Address Business Object	Used to specify the business object using which you want to create an address.  <b>Note:</b> By default, the parameter value is set to <b>C1-Address</b> . You can change the parameter value, if required. However, you must specify a business object which is already defined in the system.	Yes

### C1-TODORETRY

This algorithm is invoked when the status of the customer or membership inbound message is changed to **Rejected**. It checks whether the maximum retry attempts are met. If the retry attempt is less than or equal to the value defined in the **Maximum Retry** parameter, the status of the inbound message is changed to **Pending**. However, if the retry attempt is greater than the value defined in the **Maximum Retry** parameter, the status of the inbound message remains as **Rejected**.

**Note:** This algorithm is invoked only when the customer or membership inbound message is validated and processed through the batch process.

It contains the following parameters:

- **Maximum Retry** – Used to specify the maximum number of times the inbound message can be revalidated and reprocessed on failure.
- **Maximum Retry Element Name** – This parameter is not used at the moment.

If you do not specify any value for the **Maximum Retry** parameter, the system uses the value defined in the **To Do Maximum Retries** status option (which is defined in the lifecycle of the **C1-CustomerInboundMessage** and **C1-MemberInboundMessage** business object) to check whether the maximum retry attempts are met. If the value is not specified for the **To Do Maximum Retries** status option, the system does not allow revalidating and reprocessing an inbound message, and the status of the inbound message remains as **Rejected**.

### C1-TDCRINMSG

This algorithm is invoked when the status of the customer or membership inbound message is changed to **Rejected**. It creates a To Do using the specified To Do type and assigns it to users with the specified To Do role.

It contains the following parameters:



- **To Do Type** - Used to specify the type of notification that you want to generate when the inbound message validation or processing fails.
- **To Do Role** - Used to specify the To Do role to indicate the users to whom you want to send the notification when the inbound message validation or processing fails.

The rest of the parameters, such as **To Do Type Element Name**, **To Do Role Element Name**, **Message Category**, **Message Number**, **Characteristic Type For Log Entry**, **To Do Sort Keys Retriever Script**, **Discard Cancel Terminate Reason Element**, **Discard Cancel Terminate Reason**, **Retry Frequency**, and **Retry Frequency Element Name**, are not used at the moment.

### F1-TODOCOMPL

This algorithm completes To Do entries that are created for the business object when the business object exits the given status. It finds and completes all open To Do entries where the business object's primary key is defined as a drill key. However, if the **Exclude To Do Entries From Auto Completion** characteristic is set to **Y** for the business object, the system does not automatically complete the respective To Do entry.

## Membership Inbound Message XML Format

### Note:

We recommend you to refer the Membership Inbound Message schema in parallel while understanding the below mentioned tags. This will help you to understand how the tags are nested in the schema.

If a characteristic is defined for a person using the characteristic type specified in the **Main Subscriber Characteristic Type** parameter of the **C1-INMEMEPRC** algorithm and its value is set to the one specified in the **Main Subscriber Characteristic Value** parameter of the **C1-INMEMEPRC** algorithm, then the person is added as the main subscriber in the membership. Otherwise, the person is added as a dependent person in the membership.

Before calling the **C1-MembershipInboundMessage** inbound web service, you need to ensure that the membership inbound message contains the following tags:

Tag Name	Tag Description	Mandatory (Yes or No)								
schema	Used to specify the tags of a membership inbound message.	Yes								
characteristics	<p>You can use this tag within the following tags:</p> <table border="1"> <thead> <tr> <th>If this tag is used within...</th> <th>Then the purpose of the characteristics tag is...</th> </tr> </thead> <tbody> <tr> <td>schema</td> <td>Used to specify a list of characteristics for the membership inbound message.</td> </tr> <tr> <td>memberData</td> <td>Used to specify a list of characteristics for the person.</td> </tr> <tr> <td>memberPlanCoverages</td> <td>Used to specify a list of characteristics for the membership.</td> </tr> </tbody> </table>	If this tag is used within...	Then the purpose of the characteristics tag is...	schema	Used to specify a list of characteristics for the membership inbound message.	memberData	Used to specify a list of characteristics for the person.	memberPlanCoverages	Used to specify a list of characteristics for the membership.	No
If this tag is used within...	Then the purpose of the characteristics tag is...									
schema	Used to specify a list of characteristics for the membership inbound message.									
memberData	Used to specify a list of characteristics for the person.									
memberPlanCoverages	Used to specify a list of characteristics for the membership.									
inboundMessageCharacteristic	Used to specify a characteristic for the membership inbound message.	No								

Tag Name	Tag Description	Mandatory (Yes or No)						
adhocCharacteristicValue	Used to specify the value for the adhoc characteristic type.	Yes (Conditional) <div data-bbox="1224 289 1466 499" style="border: 1px solid black; padding: 5px;"> <p><b>Note:</b> This data is required while defining or editing an adhoc characteristic of the membership inbound message.</p> </div>						
characteristicType	You can use this tag within the following tags: <table border="1" data-bbox="594 590 1203 1707" style="width: 100%; border-collapse: collapse;"> <thead> <tr> <th data-bbox="594 590 938 737">If this tag is used within...</th> <th data-bbox="938 590 1203 737">Then the purpose of the characteristicType tag is...</th> </tr> </thead> <tbody> <tr> <td data-bbox="594 737 938 1041">inboundMessageCharacteristic</td> <td data-bbox="938 737 1203 1041">Used to specify the characteristic type. Here, you must specify a characteristic type where the characteristic entity is set to <b>Inbound Message</b>.</td> </tr> <tr> <td data-bbox="594 1041 938 1707">characteristicsList</td> <td data-bbox="938 1041 1203 1707">           Used to specify the characteristic type. If you are defining a characteristic for a:           <ul style="list-style-type: none"> <li>• <b>Person</b> - You must specify a characteristic type where the characteristic entity is set to <b>Person</b>.</li> <li>• <b>Membership</b> - You must specify a characteristic type where the characteristic entity is set to <b>Membership</b>.</li> </ul> </td> </tr> </tbody> </table>	If this tag is used within...	Then the purpose of the characteristicType tag is...	inboundMessageCharacteristic	Used to specify the characteristic type. Here, you must specify a characteristic type where the characteristic entity is set to <b>Inbound Message</b> .	characteristicsList	Used to specify the characteristic type. If you are defining a characteristic for a: <ul style="list-style-type: none"> <li>• <b>Person</b> - You must specify a characteristic type where the characteristic entity is set to <b>Person</b>.</li> <li>• <b>Membership</b> - You must specify a characteristic type where the characteristic entity is set to <b>Membership</b>.</li> </ul>	Yes (Conditional) <div data-bbox="1224 577 1466 751" style="border: 1px solid black; padding: 5px;"> <p><b>Note:</b> This data is required while defining or editing a characteristic of the respective entity.</p> </div>
If this tag is used within...	Then the purpose of the characteristicType tag is...							
inboundMessageCharacteristic	Used to specify the characteristic type. Here, you must specify a characteristic type where the characteristic entity is set to <b>Inbound Message</b> .							
characteristicsList	Used to specify the characteristic type. If you are defining a characteristic for a: <ul style="list-style-type: none"> <li>• <b>Person</b> - You must specify a characteristic type where the characteristic entity is set to <b>Person</b>.</li> <li>• <b>Membership</b> - You must specify a characteristic type where the characteristic entity is set to <b>Membership</b>.</li> </ul>							

Tag Name	Tag Description	Mandatory (Yes or No)															
effectiveDate	<p>You can use this tag within the following tags:</p> <table border="1" data-bbox="594 302 1203 867"> <thead> <tr> <th data-bbox="594 302 938 417">If this tag is used within...</th> <th data-bbox="938 302 1203 417">Then the purpose of the effectiveDate tag is...</th> </tr> </thead> <tbody> <tr> <td data-bbox="594 417 938 627">inboundMessageCharacteristic</td> <td data-bbox="938 417 1203 627">Used to specify the date from when the characteristic is effective for the membership inbound message.</td> </tr> <tr> <td data-bbox="594 627 938 867">characteristicsList</td> <td data-bbox="938 627 1203 867">Used to specify the date from when the characteristic is effective for the respective entity (i.e person or membership).</td> </tr> </tbody> </table> <p><b>Note:</b> You must specify the date in the YYYY-MM-DD format. If you do not specify the effective date, the system uses the below mentioned date while defining a characteristic for the following:</p> <table border="1" data-bbox="594 1108 1203 1961"> <thead> <tr> <th data-bbox="594 1108 760 1161">Entity</th> <th data-bbox="760 1108 964 1161">Effective Date</th> <th data-bbox="964 1108 1203 1161">Description</th> </tr> </thead> <tbody> <tr> <td data-bbox="594 1161 760 1688">Person</td> <td data-bbox="760 1161 964 1688">Earliest Policy Effective Date</td> <td data-bbox="964 1161 1203 1688">A person might have multiple policies. For example, P1 effective from 01-01-2016 and P2 effective from 01-01-2017. In such case, the system uses the effective date of the policy which is the earliest (i.e. P1) while defining characteristic for the person.</td> </tr> <tr> <td data-bbox="594 1688 760 1961">Membership</td> <td data-bbox="760 1688 964 1961">Membership Start Date</td> <td data-bbox="964 1688 1203 1961">The system uses the date from when the membership is effective in the policy plan while defining characteristic for the membership.</td> </tr> </tbody> </table>	If this tag is used within...	Then the purpose of the effectiveDate tag is...	inboundMessageCharacteristic	Used to specify the date from when the characteristic is effective for the membership inbound message.	characteristicsList	Used to specify the date from when the characteristic is effective for the respective entity (i.e person or membership).	Entity	Effective Date	Description	Person	Earliest Policy Effective Date	A person might have multiple policies. For example, P1 effective from 01-01-2016 and P2 effective from 01-01-2017. In such case, the system uses the effective date of the policy which is the earliest (i.e. P1) while defining characteristic for the person.	Membership	Membership Start Date	The system uses the date from when the membership is effective in the policy plan while defining characteristic for the membership.	No
If this tag is used within...	Then the purpose of the effectiveDate tag is...																
inboundMessageCharacteristic	Used to specify the date from when the characteristic is effective for the membership inbound message.																
characteristicsList	Used to specify the date from when the characteristic is effective for the respective entity (i.e person or membership).																
Entity	Effective Date	Description															
Person	Earliest Policy Effective Date	A person might have multiple policies. For example, P1 effective from 01-01-2016 and P2 effective from 01-01-2017. In such case, the system uses the effective date of the policy which is the earliest (i.e. P1) while defining characteristic for the person.															
Membership	Membership Start Date	The system uses the date from when the membership is effective in the policy plan while defining characteristic for the membership.															

Tag Name	Tag Description	Mandatory (Yes or No)						
characteristicValue	<p>You can use this tag within the following tags:</p> <table border="1"> <thead> <tr> <th>If this tag is used within...</th> <th>Then the purpose of the characteristicValue tag is...</th> </tr> </thead> <tbody> <tr> <td>inboundMessageCharacteristic</td> <td>Used to specify the value for the predefined characteristic type.</td> </tr> <tr> <td>characteristicsList</td> <td>Used to specify the value for the characteristic type.</td> </tr> </tbody> </table>	If this tag is used within...	Then the purpose of the characteristicValue tag is...	inboundMessageCharacteristic	Used to specify the value for the predefined characteristic type.	characteristicsList	Used to specify the value for the characteristic type.	<p>Yes (Conditional)</p> <p><b>Note:</b> This data is required while defining or editing a characteristic of the respective entity.</p>
If this tag is used within...	Then the purpose of the characteristicValue tag is...							
inboundMessageCharacteristic	Used to specify the value for the predefined characteristic type.							
characteristicsList	Used to specify the value for the characteristic type.							
characteristicValueForeignKey1	Used to specify the first value for the foreign key characteristic type.	<p>Yes (Conditional)</p> <p><b>Note:</b> This data is required while defining or editing a foreign key characteristic of the membership inbound message.</p>						
characteristicValueFK2	Used to specify the second value for the foreign key characteristic type.	No						
characteristicValueFK3	Used to specify the third value for the foreign key characteristic type.	No						
characteristicValueFK4	Used to specify the fourth value for the foreign key characteristic type.	No						
characteristicValueFK5	Used to specify the fifth value for the foreign key characteristic type.	No						
eligibilityStructureMessage	Used to specify the details of the membership including the header information for the membership inbound message.	Yes						
headerData	Used to specify the header information for the membership inbound message.	Yes						
messageType	<p>Used to specify the inbound message type using which the membership inbound message should be created in the system.</p> <p><b>Note:</b> You must specify a valid membership inbound message type which is in the <b>Active</b> status.</p>	Yes						
messageBatchID	Used to indicate the external batch job or batch run number through which the membership inbound message is created.	Yes						

Tag Name	Tag Description	Mandatory (Yes or No)						
sourceSystem	<p>You can use this tag within the following tags:</p> <table border="1" data-bbox="594 302 1203 646"> <thead> <tr> <th data-bbox="594 302 857 386">If this tag is used within...</th> <th data-bbox="857 302 1203 386">Then the purpose of the sourceSystem tag is...</th> </tr> </thead> <tbody> <tr> <td data-bbox="594 386 857 531">headerData</td> <td data-bbox="857 386 1203 531">Used to indicate the external system from where the membership inbound message is received.</td> </tr> <tr> <td data-bbox="594 531 857 646">policyData</td> <td data-bbox="857 531 1203 646">Used to indicate the source system from where the policy is originated.</td> </tr> </tbody> </table> <p><b>Note:</b> You must specify a source system which is already defined in the <b>C1-SourceSystemLookup</b> extendable lookup. It must be in the <b>Active</b> status.</p>	If this tag is used within...	Then the purpose of the sourceSystem tag is...	headerData	Used to indicate the external system from where the membership inbound message is received.	policyData	Used to indicate the source system from where the policy is originated.	Yes
If this tag is used within...	Then the purpose of the sourceSystem tag is...							
headerData	Used to indicate the external system from where the membership inbound message is received.							
policyData	Used to indicate the source system from where the policy is originated.							
sourceSystemTransID	Used to indicate the transaction in the external source system which resulted in the customer inbound message.	No						
sourceSystemSourceID	Used to specify the external source system ID.	Yes						
bo	<p>You can use this tag within the following tags:</p> <table border="1" data-bbox="594 1005 1203 1640"> <thead> <tr> <th data-bbox="594 1005 857 1089">If this tag is used within...</th> <th data-bbox="857 1005 1203 1089">Then the purpose of the bo tag is...</th> </tr> </thead> <tbody> <tr> <td data-bbox="594 1089 857 1373">schema</td> <td data-bbox="857 1089 1203 1373">           Indicates the business object using which the membership inbound message is created in the system.           <p><b>Note:</b> The system refers the value from within the <b>headerData</b> tag.</p> </td> </tr> <tr> <td data-bbox="594 1373 857 1640">headerData</td> <td data-bbox="857 1373 1203 1640">           Used to indicate the business object using which the membership inbound message should be created in the system. The valid value is:           <ul style="list-style-type: none"> <li>• C1-MemberInboundMessage</li> </ul> </td> </tr> </tbody> </table>	If this tag is used within...	Then the purpose of the bo tag is...	schema	Indicates the business object using which the membership inbound message is created in the system. <p><b>Note:</b> The system refers the value from within the <b>headerData</b> tag.</p>	headerData	Used to indicate the business object using which the membership inbound message should be created in the system. The valid value is: <ul style="list-style-type: none"> <li>• C1-MemberInboundMessage</li> </ul>	Yes
If this tag is used within...	Then the purpose of the bo tag is...							
schema	Indicates the business object using which the membership inbound message is created in the system. <p><b>Note:</b> The system refers the value from within the <b>headerData</b> tag.</p>							
headerData	Used to indicate the business object using which the membership inbound message should be created in the system. The valid value is: <ul style="list-style-type: none"> <li>• C1-MemberInboundMessage</li> </ul>							
eligibilityStructureData	Used to specify the details of a membership, such as the membership period, main subscriber, dependents, membership contracts, and membership premium for a coverage period.	Yes						

Tag Name	Tag Description	Mandatory (Yes or No)
memberData	Used to specify the details of the main subscriber or dependent person.	Yes (Conditional)  <b>Note:</b> This data is required while defining or editing a main subscriber or dependent person.
customerName	Used to specify the name of the main subscriber or dependent person.	Yes (Conditional)  <b>Note:</b> This data is required while defining a main subscriber or dependent person.
customerType	Used to indicate the type of the person.  <b>Note:</b> You must specify a value which is already defined in the <b>PER_OR_BUS_FLG</b> lookup field. It must be in the <b>Active</b> status.	Yes (Conditional)  <b>Note:</b> This data is required while defining a main subscriber or dependent person.
memberId	Used to specify the external membership ID.	No
relationship	If you are specifying the details of a main subscriber, then this tag is used to indicate how the main subscriber is related to the membership. However, if you are specifying the details of a dependent person, then this tag is used to indicate how the dependent person is related to the main subscriber.  <b>Note:</b> You must specify a contract relationship type which is already defined in the system.	Yes (Conditional)  <b>Note:</b> This data is required while defining a main subscriber or dependent person.
Id	Used to specify the identification details of the person.  <b>Note:</b> You must specify one primary identifier for a person.	Yes (Conditional)  <b>Note:</b> This data is required while defining or editing the respective information.

Tag Name	Tag Description	Mandatory (Yes or No)								
IDType	<p>You can use this tag within the following tags:</p> <table border="1" data-bbox="594 302 1198 663"> <thead> <tr> <th data-bbox="594 302 927 386">If this tag is used within...</th> <th data-bbox="927 302 1198 386">Then the purpose of the IDType tag is...</th> </tr> </thead> <tbody> <tr> <td data-bbox="594 386 927 470">Id</td> <td data-bbox="927 386 1198 470">Used to specify the person identifier type.</td> </tr> <tr> <td data-bbox="594 470 927 579">newPrimaryID</td> <td data-bbox="927 470 1198 579">Used to specify the primary person identifier type.</td> </tr> <tr> <td data-bbox="594 579 927 663">mainSubscriber</td> <td data-bbox="927 579 1198 663">Used to specify the person identifier type.</td> </tr> </tbody> </table> <p data-bbox="594 684 1198 768"><b>Note:</b> You must specify a person identifier type which is already defined in the system.</p>	If this tag is used within...	Then the purpose of the IDType tag is...	Id	Used to specify the person identifier type.	newPrimaryID	Used to specify the primary person identifier type.	mainSubscriber	Used to specify the person identifier type.	<p>Yes (Conditional)</p> <p data-bbox="1222 296 1463 470"><b>Note:</b> This data is required while defining or editing the respective information.</p>
If this tag is used within...	Then the purpose of the IDType tag is...									
Id	Used to specify the person identifier type.									
newPrimaryID	Used to specify the primary person identifier type.									
mainSubscriber	Used to specify the person identifier type.									
IDValue	<p>You can use this tag within the following tags:</p> <table border="1" data-bbox="594 854 1198 1278"> <thead> <tr> <th data-bbox="594 854 927 938">If this tag is used within...</th> <th data-bbox="927 854 1198 938">Then the purpose of the IDValue tag is...</th> </tr> </thead> <tbody> <tr> <td data-bbox="594 938 927 1022">Id</td> <td data-bbox="927 938 1198 1022">Used to specify the person identifier.</td> </tr> <tr> <td data-bbox="594 1022 927 1131">newPrimaryID</td> <td data-bbox="927 1022 1198 1131">Used to specify the primary person identifier.</td> </tr> <tr> <td data-bbox="594 1131 927 1278">mainSubscriber</td> <td data-bbox="927 1131 1198 1278">Used to indicate the main subscriber who is related to the dependent person.</td> </tr> </tbody> </table>	If this tag is used within...	Then the purpose of the IDValue tag is...	Id	Used to specify the person identifier.	newPrimaryID	Used to specify the primary person identifier.	mainSubscriber	Used to indicate the main subscriber who is related to the dependent person.	<p>Yes (Conditional)</p> <p data-bbox="1222 848 1463 1022"><b>Note:</b> This data is required while defining or editing the respective information.</p>
If this tag is used within...	Then the purpose of the IDValue tag is...									
Id	Used to specify the person identifier.									
newPrimaryID	Used to specify the primary person identifier.									
mainSubscriber	Used to indicate the main subscriber who is related to the dependent person.									
isPrimary	<p>Used to indicate whether the person identifier is a primary identifier. The valid values are:</p> <ul data-bbox="618 1394 678 1472" style="list-style-type: none"> <li>• Y</li> <li>• N</li> </ul> <p data-bbox="594 1493 1198 1570"><b>Note:</b> If you do not specify the value, by default, it is set to N.</p>	No								
newPrimaryID	Used when you want to change the primary identifier of the main subscriber or dependent person.	No								
mainSubscriber	Used to specify the primary identifier of the main subscriber.	<p>Yes (Conditional)</p> <p data-bbox="1222 1734 1463 1908"><b>Note:</b> This data is required when you are adding dependent person in a membership.</p>								

Tag Name	Tag Description	Mandatory (Yes or No)
characteristicsList	Used to specify a characteristic for the respective entity (i.e. person or membership)	Yes (Conditional)  <b>Note:</b> This data is required while defining or editing a characteristic of the respective entity.
address	Used to specify the address details of the main subscriber or dependent person.	Yes (Conditional)  <b>Note:</b> This data is required while defining or editing the address of a main subscriber or dependent person.
addressEffDate	Used to specify the date from when the address is effective for the main subscriber or dependent person.  <b>Note:</b> You must specify the date in the YYYY-MM-DD format. If you do not specify the date, by default, the system sets the effective date to the date when the address is created in the system through the membership inbound message.	Yes (Conditional)  <b>Note:</b> This data is required while editing the address of a main subscriber or dependent person.
addressType	Used to indicate whether the address is the person's mailing or seasonal address. The valid values are: <ul style="list-style-type: none"><li>• <b>MAIN</b> - Indicates that the address is the person's mailing address.</li><li>• <b>SEAS</b> - Indicates that the address is the person's seasonal address.</li></ul> <b>Note:</b> If you do not specify the address type, by default, it is set to <b>MAIN</b> . You must specify an address type which is already defined in the <b>ADDRESS_TYPE_FLG</b> lookup field. It must be in the <b>Active</b> status.	Yes (Conditional)  <b>Note:</b> This data is required while editing the address of a main subscriber or dependent person.
MailingName	Used to specify the override mailing name for the main subscriber or dependent person.	No



Tag Name	Tag Description	Mandatory (Yes or No)
address1	Used to specify the first line of the address. It may contain details, such as the house number.	Yes (Conditional) <b>Note:</b> This data is required while defining or editing the address of a main subscriber or dependent person.
address2	Used to specify the second line of the address. It may contain details, such as the apartment name.	No
address3	Used to specify the third line of the address. It may contain details, such as the street name.	No
city	Used to specify the city name.	No
state	Used to indicate the state where the city is located.	No
zip	Used to specify the zip code of the address.	No
country	Used to indicate the country where the main subscriber or dependent person is located.	Yes (Conditional) <b>Note:</b> This data is required while defining or editing the address of a main subscriber or dependent person.
attentionName	Used to specify the fourth line of the address. It may contain the landmark details.	No
phones	Used to specify the phone details of the main subscriber or dependent person.	Yes (Conditional) <b>Note:</b> This data is required while defining or editing the phone details of a main subscriber or dependent person.
phoneType	Used to indicate the type of the phone. <b>Note:</b> You must specify a phone type which is already defined in the system.	Yes (Conditional) <b>Note:</b> This data is required while defining or editing the phone details of a main subscriber or dependent person.

Tag Name	Tag Description	Mandatory (Yes or No)
phoneValue	Used to specify the phone number of the main subscriber or dependent person.	Yes (Conditional) <b>Note:</b> This data is required while defining or editing the phone details of a main subscriber or dependent person.
policyData	Used to specify information about the policy and its plan for which you want to define or edit the membership.	Yes (Conditional) <b>Note:</b> This data is required while defining or editing a membership.
policyNumber	Used to specify the policy number.	Yes (Conditional) <b>Note:</b> This data is required while defining or editing a membership.
memberPlanCoverages	Used to specify the details of the membership.	Yes (Conditional) <b>Note:</b> This data is required while defining or editing a membership.
billGroup	Used to indicate the account on which you want to create the membership premium billable charges.	No
planCode	Used to specify the plan number. <b>Note:</b> The value is stored as a characteristic on the price item. The system stores the value against the characteristic type which is specified in the <b>Plan Code Characteristic Type</b> parameter of the <b>C1-INMEMEPRC</b> algorithm.	Yes (Conditional) <b>Note:</b> This data is required while defining or editing a membership.
coverageType	Used to specify the coverage type.	No

Tag Name	Tag Description	Mandatory (Yes or No)						
rateCoverageType	<p>Used to specify the contract type. The system finds the contract of the specified contract type on the account and associates it with the membership.</p> <p><b>Note:</b> You must specify a contract type which is already defined in the <b>RATE_COVRG_CNTRACT_TYPE</b> lookup field. It must be in the <b>Active</b> status.</p> <p>The value is stored as a characteristic on the price item. The system stores the value against the characteristic type which is specified in the <b>Rate Coverage Type Characteristic Type</b> parameter of the <b>C1-INMEMEPRC</b> algorithm.</p> <p>The system derives the price item where the specified rate coverage type and plan code are defined as characteristics. The system then derives the policy plan using the derived policy ID and price item. It also checks whether the start date of the policy plan is earlier than or equal to the membership start date and the policy plan end date is later than or equal to the membership end date.</p>	<p>Yes (Conditional)</p> <p><b>Note:</b> This data is required while defining or editing a membership.</p>						
startDate	<p>You can use this tag within the following tags:</p> <table border="1" data-bbox="594 1035 1203 1864"> <thead> <tr> <th data-bbox="594 1035 857 1119">If this tag is used within...</th> <th data-bbox="857 1035 1203 1119">Then the purpose of the startDate tag is...</th> </tr> </thead> <tbody> <tr> <td data-bbox="594 1119 857 1577">memberPlanCoverages</td> <td data-bbox="857 1119 1203 1577"> <p>Used to specify the date from when the membership is effective.</p> <p><b>Note:</b> The membership start date cannot be later than the membership end date. The membership start date cannot be earlier than the policy plan start date or later than policy plan end date.</p> </td> </tr> <tr> <td data-bbox="594 1577 857 1864">premiumRateList</td> <td data-bbox="857 1577 1203 1864"> <p>Used to specify the start date of the coverage period.</p> <p><b>Note:</b> The coverage period start date cannot be earlier than the membership start date and later than the coverage period end date.</p> </td> </tr> </tbody> </table>	If this tag is used within...	Then the purpose of the startDate tag is...	memberPlanCoverages	<p>Used to specify the date from when the membership is effective.</p> <p><b>Note:</b> The membership start date cannot be later than the membership end date. The membership start date cannot be earlier than the policy plan start date or later than policy plan end date.</p>	premiumRateList	<p>Used to specify the start date of the coverage period.</p> <p><b>Note:</b> The coverage period start date cannot be earlier than the membership start date and later than the coverage period end date.</p>	<p>Yes (Conditional)</p> <p><b>Note:</b> This data is required in the following scenarios:</p> <ul style="list-style-type: none"> <li>• While defining or editing a membership</li> <li>• While creating or editing a membership premium billable charge</li> </ul>
If this tag is used within...	Then the purpose of the startDate tag is...							
memberPlanCoverages	<p>Used to specify the date from when the membership is effective.</p> <p><b>Note:</b> The membership start date cannot be later than the membership end date. The membership start date cannot be earlier than the policy plan start date or later than policy plan end date.</p>							
premiumRateList	<p>Used to specify the start date of the coverage period.</p> <p><b>Note:</b> The coverage period start date cannot be earlier than the membership start date and later than the coverage period end date.</p>							

Tag Name	Tag Description	Mandatory (Yes or No)						
endDate	<p>You can use this tag within the following tags:</p> <table border="1" data-bbox="594 302 1198 1131"> <thead> <tr> <th data-bbox="594 302 857 386">If this tag is used within...</th> <th data-bbox="857 302 1198 386">Then the purpose of the endDate tag is...</th> </tr> </thead> <tbody> <tr> <td data-bbox="594 386 857 842">memberPlanCoverages</td> <td data-bbox="857 386 1198 842"> <p>Used to specify the date till when the membership is effective.</p> <p><b>Note:</b> The membership end date cannot be earlier than the membership start date. The membership end date cannot be earlier than the policy plan start date or later than policy plan end date.</p> </td> </tr> <tr> <td data-bbox="594 842 857 1131">premiumRateList</td> <td data-bbox="857 842 1198 1131"> <p>Used to specify the end date of the coverage period.</p> <p><b>Note:</b> The coverage period end date cannot be later than the membership end date and earlier than the coverage period start date.</p> </td> </tr> </tbody> </table>	If this tag is used within...	Then the purpose of the endDate tag is...	memberPlanCoverages	<p>Used to specify the date till when the membership is effective.</p> <p><b>Note:</b> The membership end date cannot be earlier than the membership start date. The membership end date cannot be earlier than the policy plan start date or later than policy plan end date.</p>	premiumRateList	<p>Used to specify the end date of the coverage period.</p> <p><b>Note:</b> The coverage period end date cannot be later than the membership end date and earlier than the coverage period start date.</p>	<p>Yes (Conditional)</p> <p><b>Note:</b> This data is required in the following scenarios:</p> <ul style="list-style-type: none"> <li>• While defining or editing a membership</li> <li>• While creating or editing a membership premium billable charge</li> </ul>
If this tag is used within...	Then the purpose of the endDate tag is...							
memberPlanCoverages	<p>Used to specify the date till when the membership is effective.</p> <p><b>Note:</b> The membership end date cannot be earlier than the membership start date. The membership end date cannot be earlier than the policy plan start date or later than policy plan end date.</p>							
premiumRateList	<p>Used to specify the end date of the coverage period.</p> <p><b>Note:</b> The coverage period end date cannot be later than the membership end date and earlier than the coverage period start date.</p>							
productCode	Used to indicate the product to which the price item is mapped.	No						
premiumRates	Used to specify the premium details of the membership.	<p>Yes (Conditional)</p> <p><b>Note:</b> This data is required while creating or editing a membership premium billable charge.</p>						
premiumRateList	Used to specify the premium for a coverage period.	<p>Yes (Conditional)</p> <p><b>Note:</b> This data is required while creating or editing a membership premium billable charge.</p>						

Tag Name	Tag Description	Mandatory (Yes or No)
premiumAmount	Used to specify the premium amount for the coverage period.	Yes (Conditional) <b>Note:</b> This data is required while creating or editing a membership premium billable charge.

The following table lists and describes the tags which are available in the membership inbound message schema, but should not be included in the XML file:

Tag Name	Tag Description						
c1InboundMessage	Displays the inbound message ID.						
c1InboundMessageType	Indicates the inbound message type using which the membership inbound message is created in the system.						
boStatus	Displays the status of the membership inbound message.						
statusReason	Indicates the reason why the status of the membership inbound message is changed.						
c1SourceSystem	Indicates the external system from where the membership inbound message is received.						
c1ExternalTransactionId	Indicates the transaction in the external source system which resulted in the membership inbound message.						
c1ExternalBatchId	Indicates the external batch job or batch run number through which the membership inbound message is created.						
c1ExternalSourceId	Displays the external source system ID.						
person	At present, this tag is not supported in a membership inbound message.						
statusDateTime	Displays the date and time when the status of the membership inbound message is changed in the system.						
creationDateTime	Displays the date and time when the membership inbound message is created in the system.						
version	This tag appears within the following parent tags: <table border="1" data-bbox="683 1488 1463 1833"> <thead> <tr> <th>Parent Tag</th> <th>Then the purpose of the version tag is...</th> </tr> </thead> <tbody> <tr> <td>schema</td> <td>Displays the version of the membership inbound message.</td> </tr> <tr> <td>inboundMessageCharacteristic</td> <td>Displays the version of the characteristic defined for the membership inbound message.</td> </tr> </tbody> </table>	Parent Tag	Then the purpose of the version tag is...	schema	Displays the version of the membership inbound message.	inboundMessageCharacteristic	Displays the version of the characteristic defined for the membership inbound message.
Parent Tag	Then the purpose of the version tag is...						
schema	Displays the version of the membership inbound message.						
inboundMessageCharacteristic	Displays the version of the characteristic defined for the membership inbound message.						
searchCharacteristicValue	At present, this tag is not supported in the membership inbound message.						

Tag Name	Tag Description
messageID	Displays the inbound message ID.
status	Displays the status of the membership inbound message.
createDateTime	Displays the date and time when the membership inbound message is created in the system.
ORMBcreateDateTime	Displays the date and time when the membership inbound message is created in the system.
toDoRetry	Displays the information about the retry option used for the membership inbound message.  <b>Note:</b> This information appears at the bottom of the inbound message in the <b>Inbound Message Content</b> zone once the membership inbound message is validated and processed either through the user interface or batch process.
retryDateTime	Displays the date and time when the retry option is used to change the status of the membership inbound message from <b>Rejected</b> to <b>Pending</b> .
numberOfRetries	Indicates the number of times the retry option is used for the membership inbound message.
currentErrorState	Indicates the status to which the membership inbound message is transitioned when its validation or processing fails. The valid value is: <ul style="list-style-type: none"> <li>REJECTED</li> </ul>
isRetried	Indicates whether the retry option is used to change the status of the membership inbound message. The valid values are: <ul style="list-style-type: none"> <li>true</li> <li>false</li> </ul>

### Related Topics

For more information on...	See...
Membership Inbound Message Schema	<a href="#">Membership Inbound Message Schema</a> on page 1822
Sample Membership Inbound Message	<a href="#">Sample Membership Inbound Message</a> on page 1824

## Membership Inbound Message Schema

```
<schema>
  <clInboundMessage></clInboundMessage>
  <clInboundMessageType></clInboundMessageType>
  <bo></bo>
  <boStatus></boStatus>
  <statusReason></statusReason>
  <clSourceSystem></clSourceSystem>
  <clExternalTransactionId></clExternalTransactionId>
  <clExternalBatchId></clExternalBatchId>
  <clExternalSourceId></clExternalSourceId>
  <person></person>
  <statusDateTime></statusDateTime>
  <creationDateTime></creationDateTime>
  <version></version>
  <characteristics>
```

```

<inboundMessageCharacteristic>
  <adhocCharacteristicValue></adhocCharacteristicValue>
  <characteristicType></characteristicType>
  <effectiveDate></effectiveDate>
  <characteristicValue></characteristicValue>
  <characteristicValueForeignKey1></characteristicValueForeignKey1>
  <characteristicValueFK2></characteristicValueFK2>
  <characteristicValueFK3></characteristicValueFK3>
  <characteristicValueFk4></characteristicValueFk4>
  <characteristicValueFK5></characteristicValueFK5>
  <searchCharacteristicValue></searchCharacteristicValue>
  <version></version>
</inboundMessageCharacteristic>
</characteristics>
<eligibilityStructureMessage>
  <headerData>
    <messageType></messageType>
    <messageID></messageID>
    <messageBatchID></messageBatchID>
    <sourceSystem></sourceSystem>
    <sourceSystemTransID></sourceSystemTransID>
    <sourceSystemSourceID></sourceSystemSourceID>
    <bo></bo>
    <status></status>
    <createDateTime></createDateTime>
    <ORMBcreateDateTime></ORMBcreateDateTime>
  </headerData>
  <eligibilityStructureData>
    <memberData>
      <customerName></customerName>
      <customerType></customerType>
      <memberId></memberId>
      <relationship></relationship>
      <Id>
        <IDType></IDType>
        <IDValue></IDValue>
        <isPrimary></isPrimary>
      </Id>
      <newPrimaryID>
        <IDType></IDType>
        <IDValue></IDValue>
      </newPrimaryID>
      <mainSubscriber>
        <IDType></IDType>
        <IDValue></IDValue>
      </mainSubscriber>
      <characteristics>
        <characteristicsList>
          <characteristicType></characteristicType>
          <characteristicValue></characteristicValue>
          <effectiveDate></effectiveDate>
        </characteristicsList>
      </characteristics>
      <address>
        <addressEffDate></addressEffDate>
        <addressType></addressType>
        <MailingName></MailingName>
        <address1></address1>
        <address2></address2>
        <address3></address3>
        <city></city>
        <state></state>
        <zip></zip>
        <country></country>
      </address>
    </memberData>
  </eligibilityStructureData>
</eligibilityStructureMessage>

```

```

        <attentionName></attentionName>
    </address>
    <phones>
        <phoneType></phoneType>
        <phoneValue></phoneValue>
    </phones>
</memberData>
<policyData>
    <policyNumber></policyNumber>
    <sourceSystem></sourceSystem>
    <memberPlanCoverages>
        <billGroup></billGroup>
        <planCode></planCode>
        <coverageType></coverageType>
        <rateCoverageType></rateCoverageType>
        <startDate></startDate>
        <endDate></endDate>
        <productCode></productCode>
        <characteristics>
            <characteristicsList>
                <characteristicType></characteristicType>
                <characteristicValue></characteristicValue>
                <effectiveDate></effectiveDate>
            </characteristicsList>
        </characteristics>
        <premiumRates>
            <premiumRateList>
                <startDate></startDate>
                <endDate></endDate>
                <premiumAmount></premiumAmount>
            </premiumRateList>
        </premiumRates>
    </memberPlanCoverages>
</policyData>
</eligibilityStructureData>
</eligibilityStructureMessage>
<toDoRetry>
    <retryDateTime></retryDateTime>
    <numberOfRetries></numberOfRetries>
    <currentErrorState></currentErrorState>
    <isRetried></isRetried>
</toDoRetry>
</schema>

```

## Sample Membership Inbound Message

Using the below example, you can do the following:

- Add a member to an existing membership
- Create a pass-through billable charge for membership premium

Policy	Policy Plan	Main Subscriber of Membership	Dependent Member
WT1256678	WXXPL	Williams, Garry (COREG=76578)	Williams, John

```

<eligibilityStructureMessage>
  <headerData>
    <messageType>C1-MEMBERSHIP-INB-MSG-TYPE</messageType>
    <messageID>PGPRIME6600</messageID>
    <messageBatchID>250</messageBatchID>

```



```

<sourceSystem>SMALLPRIME</sourceSystem>
<sourceSystemTransID>01P300</sourceSystemTransID>
<sourceSystemSourceID>00100</sourceSystemSourceID>
<bo>C1-MemberInboundMessage</bo>
<status>PENDING</status>
<createDateTime>2015-01-01-14.06.01</createDateTime>
<ORMBcreateDateTime>2015-05-28-15.06.01</ORMBcreateDateTime>
</headerData>
<eligibilityStructureData>
  <memberData>
    <customerName>Williams, John</customerName>
    <customerType>P</customerType>
    <memberId>233443533285</memberId>
    <relationship>MEM</relationship>
    <newPrimaryID></newPrimaryID>
    <mainSubscriber>
      <IDType>COREG</IDType>
      <IDValue>76578</IDValue>
    </mainSubscriber>
    <characteristics>
      <characteristicsList>
        <characteristicType>C1-GENDR</characteristicType>
        <characteristicValue>MALE</characteristicValue>
      </characteristicsList>
      <characteristicsList>
        <characteristicType>C1DEPCD</characteristicType>
        <characteristicValue>MEM</characteristicValue>
      </characteristicsList>
      <characteristicsList>
        <characteristicType>C1MARSTA</characteristicType>
        <characteristicValue>M</characteristicValue>
      </characteristicsList>
      <characteristicsList>
        <characteristicType>C1_BRTDT</characteristicType>
        <characteristicValue>1981-09-30</characteristicValue>
      </characteristicsList>
    </characteristics>
    <Id>
      <IDType>COREG</IDType>
      <IDValue>67788</IDValue>
      <isPrimary>Y</isPrimary>
    </Id>
    <address>
      <addressEffDate>2017-01-01</addressEffDate>
      <addressType>MAIN</addressType>
      <address1>Apartment 405</address1>
      <address2>Rockaway Valley Road</address2>
      <city>Boonton</city>
      <state>NJ</state>
      <zip>07005</zip>
      <country>USA</country>
      <attentionName>Near Canterbury Road Junction</attentionName>
    </address>
    <phones>
      <phoneType>FAX</phoneType>
      <phoneValue>(862) 555-0199</phoneValue>
    </phones>
  </memberData>
  <policyData>
    <policyNumber>WT1256678</policyNumber>
    <sourceSystem>SMALLPRIME</sourceSystem>
    <memberPlanCoverages>
      <billGroup>126535</billGroup>
      <planCode>WXXPL</planCode>
    </memberPlanCoverages>
  </policyData>

```

```

<rateCoverageType>CMM</rateCoverageType>
<startDate>2017-01-01</startDate>
<endDate>2017-09-25</endDate>
<characteristics>
  <characteristicsList>
    <characteristicType>C1CVTIER</characteristicType>
    <characteristicValue>EC</characteristicValue>
    <effectiveDate>2017-01-01</effectiveDate>
  </characteristicsList>
</characteristics>
<premiumRates>
  <premiumRateList>
    <startDate>2017-01-01</startDate>
    <endDate>2017-09-25</endDate>
    <premiumAmount>500</premiumAmount>
  </premiumRateList>
</premiumRates>
</memberPlanCoverages>
</policyData>
</eligibilityStructureData>
</eligibilityStructureMessage>

```

## ASO Customer Inbound Message

---

On calling the **C1-ASOCustomerInboundMessage** web service, you can create an ASO customer inbound message using an ASO customer inbound message type. You can create an ASO customer inbound message type using the **ASO Customer Inbound Message Type (C1-ASOCustomerInboundMsgType)** business object. The ASO customer inbound message type helps the system to determine:

- **Inbound Message Business Object** - The business object using which the ASO customer inbound message should be created in the system. You must specify the **ASO Customer Inbound Message (C1-ASOCustomerInboundMessage)** business object in the ASO customer inbound message type.
- **Person Business Object** - The business object using which the person should be created in the system. You must specify the **Health Care Customer (C1-HCCustomer)** business object in the ASO customer inbound message type.
- **Account Business Object** - The business object using which the account should be created in the system. You must specify the **Health Care Account (C1-HCAccount)** business object in the ASO customer inbound message type.
- **Policy Type** - The policy type indicates the policy business object using which the policy should be created in the system. You must specify the **ASO Policy (C1-ASOPolicy)** business object in the policy type.
- **Policy Plan Business Object** - The business object using which the policy plan should be created in the system. You must specify the **Policy Plan (C1-PolicyPlan)** business object in the ASO customer inbound message type.

The **C1-ASOCustomerInboundMessage** web service enables you to do the following:

- Create or edit a parent customer
- Create or edit the bill groups of the parent customer
- Create or edit the accounts of a bill group
- Create or edit auto pay instructions of an account
- Create or edit the self-funded policies of a bill group
- Create or edit the plans of a self-funded policy

The following table describes how the system behaves when the respective entity information is given in an ASO customer inbound message:

Entity	System Behavior
Parent Customer	The system creates the person whose person type is set to <b>PG</b> .
Bill Group	The system creates the person whose person type is set to <b>BG</b> . The bill group is related to the parent customer using the person relationship type which is specified in the <b>Person Relationship Type</b> option type of the <b>C1-ASOBLLNG</b> feature configuration.
Account	While creating an account, the system defines the <b>Invoice Type</b> characteristic for the account. It stores the account type given in the account information in the characteristic type which is specified in the <b>Invoice Type Characteristic Type</b> option type of the <b>C1-ASOBLLNG</b> feature configuration.
Policy	If the policy information is given for a bill group, the system creates the self-funded policy using the policy type which is specified in the ASO customer inbound message type. In addition, it does the following: <ul style="list-style-type: none"> <li>• Associates the bill group with the policy using the policy person role which is specified in the <b>Bill Group Policy Person Role</b> option type of the <b>C1-ASOBLLNG</b> feature configuration</li> <li>• Associates the parent customer with the policy using the policy person role which is specified in the <b>Parent Customer Policy Person Role</b> option type of the <b>C1-ASOBLLNG</b> feature configuration</li> </ul>
Policy Plan	The system creates the plan for the self-funded policy.

On calling the **C1-ASOCustomerInboundMessage** web service, an ASO customer inbound message is created in the **Pending** status. When the **Customer Inbound Message Periodic Monitor (C1-CUSIN)** batch is executed, the system checks whether there are any ASO customer inbound messages in the **Pending** status. If there is an ASO customer inbound message in the **Pending** status, the system validates the ASO customer inbound message. If an ASO customer inbound message is successfully validated, it is processed further and the entities are either created or updated in the system based on the available information.

Alternatively, the system enables you to submit the ASO customer inbound messages for validation and processing from the user interface. On submitting an ASO customer inbound message, the system validates the ASO customer inbound message. If an ASO customer inbound message is successfully validated, it is processed further and the required entities are created or updated in the system based on the available information.

Once all required entities are created or updated in the system, the status of the ASO customer inbound message is changed to **Processed**. If any error occurs while validating or processing an ASO customer inbound message, the status of the ASO customer inbound message is changed to **Rejected**. The system enables you to either reprocess or void a rejected ASO customer inbound message. The system can reprocess an ASO customer inbound message only when its status is changed to **Pending**. Using the **Retry** option, you can change the status of the ASO customer inbound message from **Rejected** to **Pending**. The **Customer Inbound Message Periodic Monitor (C1-CUSIN)** batch will then reconsider and reprocess the ASO customer inbound message.

You can also configure the system such that the batch can automatically retry to process the rejected ASO customer inbound messages. However, it will attempt to retry only when the **Maximum Retry** parameter in the **Retry for To Dos (C1-TODORETRY)** algorithm is set to a value greater than zero. Also, the maximum number of times the batch can attempt to retry and reprocess an ASO customer inbound message depends on the value defined in the **Maximum Retry** parameter.

#### **Related Topics**

For more information on...	See...
How to setup the <b>C1-ASOBLLNG</b> feature configuration	<a href="#">Setting the C1-ASOBLLNG Feature Configuration</a> on page 2889

## Prerequisites

To use the ASO customer inbound message feature, you need to do the following:

- Define the required ASO customer inbound message types in the system.
- Define the required characteristic types where the characteristic entity is set to **Inbound Message Type**.
- Define the required characteristic types where the characteristic entity is set to **Inbound Message**.
- Define the values for the required parameters in the **C1-ASOCINVAL**, **C1-ASOCINPRC**, **C1-TODORETRY**, and **C1-TDCRINMSG** algorithms.
- Define the values for the **C1-SourceSystemLookup** extendable lookup.
- Define the values for the **ADDRESS\_TYPE\_FLG** and **RUNOUT\_ADM\_OPT\_FLG** lookup fields.
- Set the values for the following option types in the **C1-ASOBLNG** feature configuration:
  - Person Relationship Type
  - Bill Group Policy Person Role
  - Parent Customer Policy Person Role
  - Invoice Type Characteristic Type
- Define the required divisions, person identifier types, account identifier types, phone types, person relationship types, customer classes, bill cycles, bill route types, auto pay route types, auto pay sources, policy person roles, price items, and characteristic types in the application.
- Set the batch control type of the **Customer Inbound Message Periodic Monitor (C1-CUSIN)** to **Timed** and define the following attributes:
  - Time Interval
  - Timer Active
  - User ID
  - Batch Language
  - Email Address

### Related Topics

For more information on...	See...
How to setup the <b>C1-ASOBLNG</b> feature configuration	<a href="#">Setting the C1-ASOBLNG Feature Configuration</a> on page 2889

## ASO Customer Inbound Message Status Transition through User Interface

The following figure graphically indicates how an ASO customer inbound message moves from one status to another when it is validated and processed through the user interface:

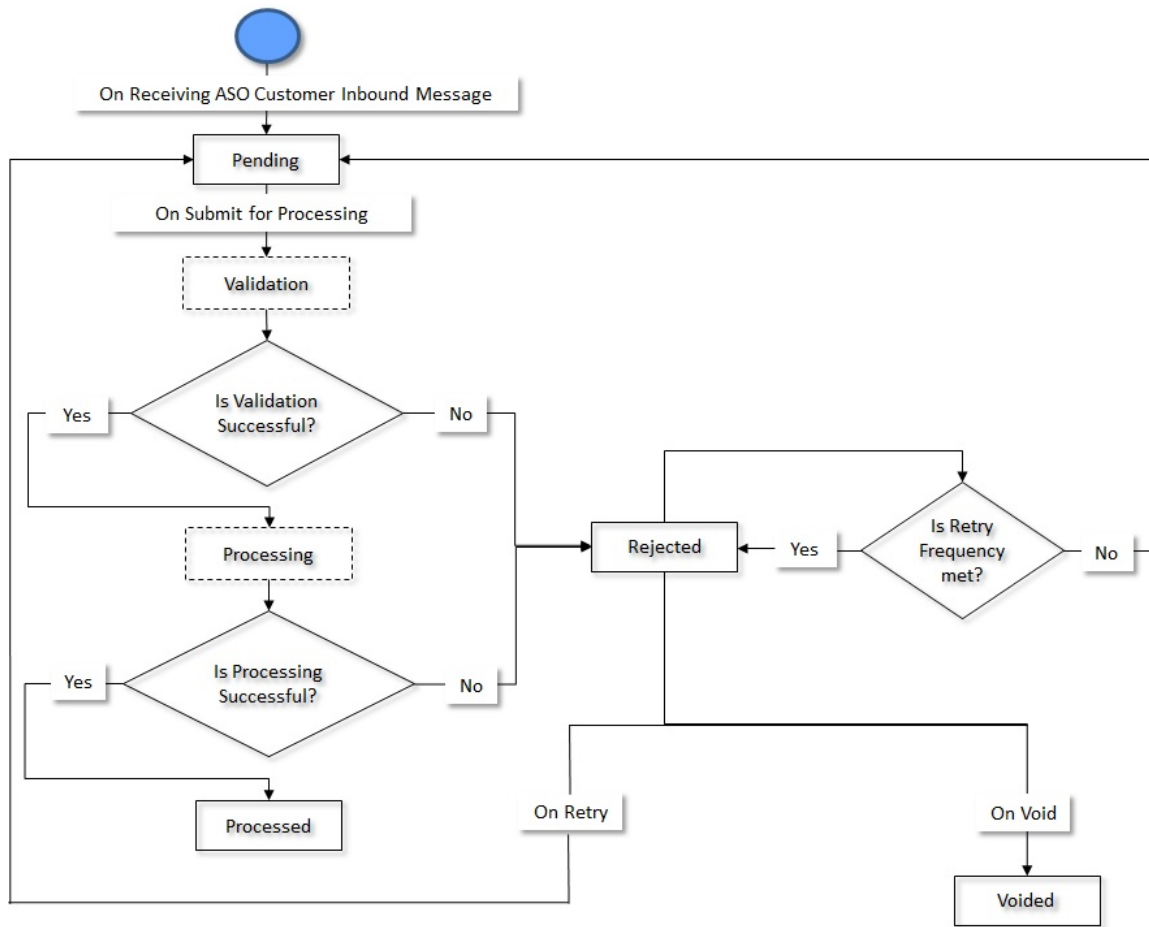

### ASO Customer Inbound Message Status Transition through a Batch Process

The following figure graphically indicates how an ASO customer inbound message moves from one status to another when it is validated and processed through the **Customer Inbound Message Periodic Monitor (C1-CUSIN)** batch:

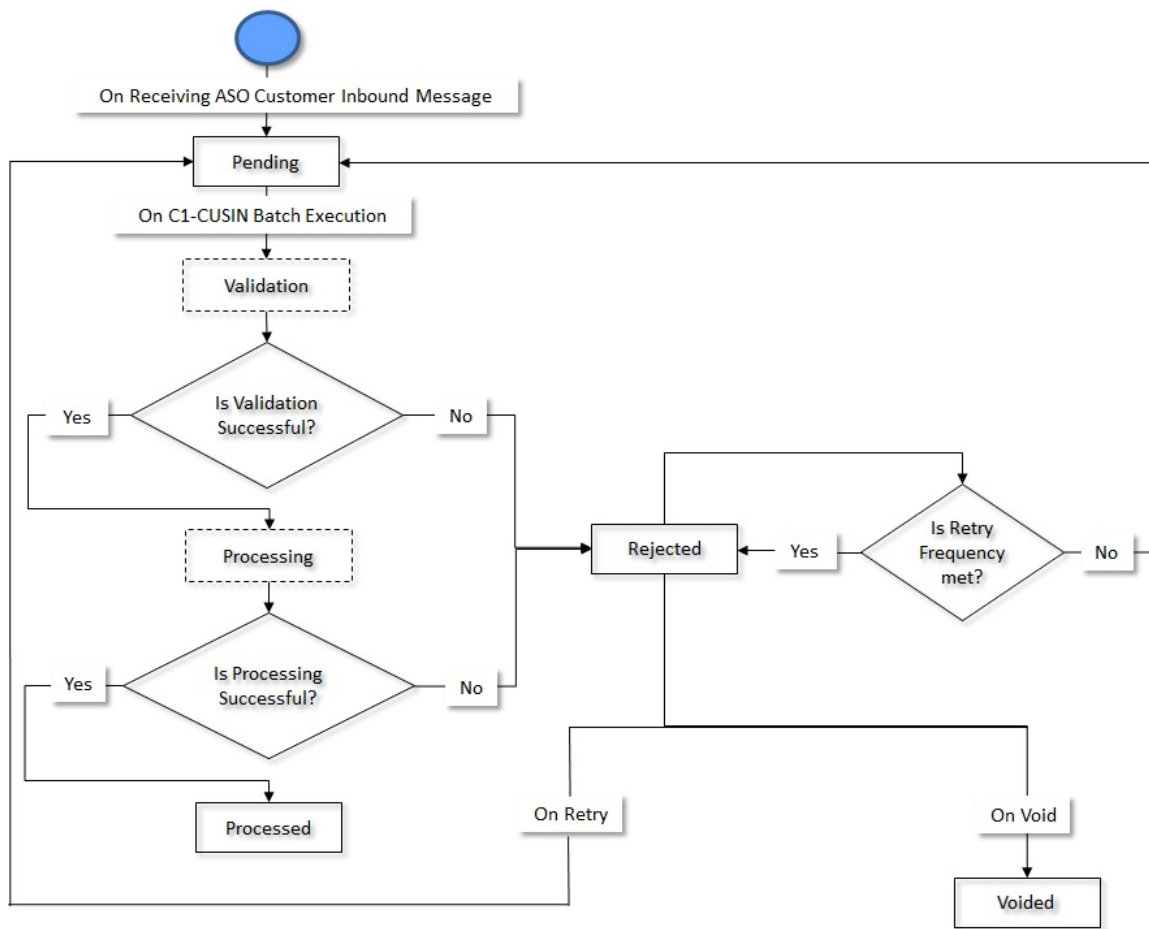

## Algorithms Used in C1-ASOCustomerInboundMessage

The following table lists the algorithms which are used in the lifecycle of the **C1-ASOCustomerInboundMessage** business object:

Status	System Event	Algorithm	Algorithm Type	Description
Pending	Monitor	C1-AT-RQJ	C1-GEN-BOMNJ	Refer to <a href="#">C1-AT-RQJ</a> on page 1762.
Validation	Monitor	F1-AT-RQJ	F1-GEN-BOMNJ	Refer to <a href="#">F1-AT-RQJ</a> on page 1257.
	Enter	C1-ASOCINVAL	C1-ASOCINVAL	Refer to <a href="#">C1-ASOCINVAL</a> on page 1831.
Processing	Monitor	F1-AT-RQJ	F1-GEN-BOMNJ	Refer to <a href="#">F1-AT-RQJ</a> on page 1257.
	Enter	C1-ASOCINPRC	C1-ASOCINPRC	Refer to <a href="#">C1-ASOCINPRC</a> on page 1832.
Rejected	Monitor	C1-TODORETRY	C1-TODORETRY	Refer to <a href="#">C1-TODORETRY</a> on page 1772.

Status	System Event	Algorithm	Algorithm Type	Description
	Enter	C1-TDCRINMSG	F1-TDCREATE	Refer to <a href="#">C1-TDCRINMSG</a> on page 1772.
Processed	-	-	-	-
Voided	-	-	-	-

### C1-AT-RQJ

This algorithm is invoked when the status of the customer or membership inbound message is changed to **Pending**. If the **isRetried** flag in the inbound message is set to **true**, it resets the flag to **false**.

It contains the following parameters:

- **Next Status** – Used when you want to override the default next status specified in the lifecycle.
- **Next Transition Condition** – Used when you want to override the default next transition condition specified in the lifecycle.

**Note:** At a time, you can specify value for either the **Next Status** or **Next Transition Condition** parameter. If you don't specify any value for these parameters, the system will transition the business object to the default next status specified in its lifecycle.

### F1-AT-RQJ

This algorithm transitions the current status of the business object to the specified status. It contains the following parameters:

- **Next Status** – Used when you want to override the default next status specified in the lifecycle.
- **Next Transition Condition** – Used when you want to override the default next transition condition specified in the lifecycle.

At a time, you can specify value for either the **Next Status** or **Next Transition Condition** parameter. If you don't specify any value for these parameters, the system will transition the business object to the default next status specified in its lifecycle.

### C1-ASOCINVAL

This algorithm is invoked when you execute the **Customer Inbound Message Periodic Monitor (C1-CUSIN)** batch or click the **Submit for Processing** button in the **Inbound Message** screen. It validates the ASO customer inbound message which is in the **Pending** status. It checks the following:

- Whether the parent customer information exists in the ASO customer inbound message.
- Whether the primary identifier is specified for the parent customer and bill group.
- Whether multiple primary identifiers are not specified for the parent customer and bill group.
- Whether the expiration year and month are specified in the account's auto pay details when the **Expiration Date Required** option is selected for the tender type which is specified in the auto pay source.
- Whether the expiration year is not earlier than 1755.
- Whether the expiration month lies between 1 and 12.

If the validation fails due to any reason, the status of the ASO customer inbound message is changed to **Rejected**. In addition, the appropriate log entry is added which you can view in the **Inbound Message Log** zone.

It contains the following parameters:

- **Next Status** - Used when you want to override the default next status specified in the lifecycle.

- **Next Transition Condition** - Used when you want to override the default next transition condition specified in the lifecycle.

**Note:** At a time, you can specify value for either the **Next Status** or **Next Transition Condition** parameter. If you don't specify any value for these parameters, the system will transition the business object to the default next status specified in its lifecycle.

### C1-ASOCINPRC

This algorithm is invoked once an ASO customer inbound message is successfully validated. It processes the ASO customer inbound message and accordingly creates or updates a person (parent customer and bill group), account (including automatic payment options), policy and policy plan.

If the processing fails due to any reason, the status of the ASO customer inbound message is changed to **Rejected**. In addition, the appropriate log entry is added which you can view in the **Inbound Message Log** zone.

It contains the following parameters:

- **Next Status** - Used when you want to override the default next status specified in the lifecycle.
- **Next Transition Condition** - Used when you want to override the default next transition condition specified in the lifecycle.

**Note:** At a time, you can specify value for either the **Next Status** or **Next Transition Condition** parameter. If you don't specify any value for these parameters, the system will transition the business object to the default next status specified in its lifecycle.

### C1-TODORETRY

This algorithm is invoked when the status of the customer or membership inbound message is changed to **Rejected**. It checks whether the maximum retry attempts are met. If the retry attempt is less than or equal to the value defined in the **Maximum Retry** parameter, the status of the inbound message is changed to **Pending**. However, if the retry attempt is greater than the value defined in the **Maximum Retry** parameter, the status of the inbound message remains as **Rejected**.

**Note:** This algorithm is invoked only when the customer or membership inbound message is validated and processed through the batch process.

It contains the following parameters:

- **Maximum Retry** – Used to specify the maximum number of times the inbound message can be revalidated and reprocessed on failure.
- **Maximum Retry Element Name** – This parameter is not used at the moment.

If you do not specify any value for the **Maximum Retry** parameter, the system uses the value defined in the **To Do Maximum Retries** status option (which is defined in the lifecycle of the **C1-CustomerInboundMessage** and **C1-MemberInboundMessage** business object) to check whether the maximum retry attempts are met. If the value is not specified for the **To Do Maximum Retries** status option, the system does not allow revalidating and reprocessing an inbound message, and the status of the inbound message remains as **Rejected**.

### C1-TDCRINMSG

This algorithm is invoked when the status of the customer or membership inbound message is changed to **Rejected**. It creates a To Do using the specified To Do type and assigns it to users with the specified To Do role.

It contains the following parameters:

- **To Do Type** - Used to specify the type of notification that you want to generate when the inbound message validation or processing fails.
- **To Do Role** - Used to specify the To Do role to indicate the users to whom you want to send the notification when the inbound message validation or processing fails.



The rest of the parameters, such as **To Do Type Element Name**, **To Do Role Element Name**, **Message Category**, **Message Number**, **Characteristic Type For Log Entry**, **To Do Sort Keys Retriever Script**, **Discard Cancel Terminate Reason Element**, **Discard Cancel Terminate Reason**, **Retry Frequency**, and **Retry Frequency Element Name**, are not used at the moment.

## ASO Customer Inbound Message XML Format

**Note:** We recommend you to refer the ASO Customer Inbound Message schema in parallel while understanding the below mentioned tags. This will help you to understand how the tags are nested in the schema.

Before calling the **C1-ASOCustomerInboundMessage** inbound web service, you need to ensure that the ASO customer inbound message contains the following tags:

Tag Name	Tag Description	Mandatory (Yes or No)						
schema	Used to specify the tags of an ASO customer inbound message.	Yes						
bo	Used to indicate the business object using which the ASO customer inbound message should be created in the system. The valid value is: <ul style="list-style-type: none"> <li>C1-ASOCustomerInboundMessage</li> </ul>	Yes						
messageType	<p>You can use this tag within the following tags:</p> <table border="1"> <thead> <tr> <th>If this tag is used within...</th> <th>Then the purpose of the messageType tag is...</th> </tr> </thead> <tbody> <tr> <td>schema</td> <td>Indicates the ASO customer inbound message type using which the ASO customer inbound message is created in the system.  <b>Note:</b> The system refers the value from within the <b>headerData</b> tag.</td> </tr> <tr> <td>headerData</td> <td>Used to specify the ASO customer inbound message type using which the ASO customer inbound message should be created in the system.</td> </tr> </tbody> </table> <p><b>Note:</b> You must specify a valid ASO customer inbound message type which is in the <b>Active</b> status.</p>	If this tag is used within...	Then the purpose of the messageType tag is...	schema	Indicates the ASO customer inbound message type using which the ASO customer inbound message is created in the system.  <b>Note:</b> The system refers the value from within the <b>headerData</b> tag.	headerData	Used to specify the ASO customer inbound message type using which the ASO customer inbound message should be created in the system.	Yes
If this tag is used within...	Then the purpose of the messageType tag is...							
schema	Indicates the ASO customer inbound message type using which the ASO customer inbound message is created in the system.  <b>Note:</b> The system refers the value from within the <b>headerData</b> tag.							
headerData	Used to specify the ASO customer inbound message type using which the ASO customer inbound message should be created in the system.							

Tag Name	Tag Description	Mandatory (Yes or No)								
sourceSystem	<p>You can use this tag within the following tags:</p> <table border="1" data-bbox="570 302 1190 898"> <thead> <tr> <th data-bbox="570 302 837 386">If this tag is used within...</th> <th data-bbox="837 302 1190 386">Then the purpose of the sourceSystem tag is...</th> </tr> </thead> <tbody> <tr> <td data-bbox="570 386 837 638">schema</td> <td data-bbox="837 386 1190 638">           Indicates the external system from where the ASO customer inbound message is received.   <b>Note:</b> The system refers the value from within the <b>headerData</b> tag.         </td> </tr> <tr> <td data-bbox="570 638 837 785">headerData</td> <td data-bbox="837 638 1190 785">Used to indicate the external system from where the ASO customer inbound message is received.</td> </tr> <tr> <td data-bbox="570 785 837 898">policyData</td> <td data-bbox="837 785 1190 898">Used to indicate the source system from where the policy is originated.</td> </tr> </tbody> </table> <p><b>Note:</b> You must specify a source system which is already defined in the <b>C1-SourceSystemLookup</b> extendable lookup. It must be in the <b>Active</b> status.</p>	If this tag is used within...	Then the purpose of the sourceSystem tag is...	schema	Indicates the external system from where the ASO customer inbound message is received.  <b>Note:</b> The system refers the value from within the <b>headerData</b> tag.	headerData	Used to indicate the external system from where the ASO customer inbound message is received.	policyData	Used to indicate the source system from where the policy is originated.	Yes
If this tag is used within...	Then the purpose of the sourceSystem tag is...									
schema	Indicates the external system from where the ASO customer inbound message is received.  <b>Note:</b> The system refers the value from within the <b>headerData</b> tag.									
headerData	Used to indicate the external system from where the ASO customer inbound message is received.									
policyData	Used to indicate the source system from where the policy is originated.									
externalTransactionId	<p>You can use this tag within the following tags:</p> <table border="1" data-bbox="570 1121 1190 1701"> <thead> <tr> <th data-bbox="570 1121 837 1234">If this tag is used within...</th> <th data-bbox="837 1121 1190 1234">Then the purpose of the externalTransactionId tag is...</th> </tr> </thead> <tbody> <tr> <td data-bbox="570 1234 837 1524">schema</td> <td data-bbox="837 1234 1190 1524">           Indicates the transaction in the external source system which resulted in the ASO customer inbound message.   <b>Note:</b> The system refers the value from within the <b>headerData</b> tag.         </td> </tr> <tr> <td data-bbox="570 1524 837 1701">headerData</td> <td data-bbox="837 1524 1190 1701">Used to indicate the transaction in the external source system which resulted in the ASO customer inbound message.</td> </tr> </tbody> </table>	If this tag is used within...	Then the purpose of the externalTransactionId tag is...	schema	Indicates the transaction in the external source system which resulted in the ASO customer inbound message.  <b>Note:</b> The system refers the value from within the <b>headerData</b> tag.	headerData	Used to indicate the transaction in the external source system which resulted in the ASO customer inbound message.	No		
If this tag is used within...	Then the purpose of the externalTransactionId tag is...									
schema	Indicates the transaction in the external source system which resulted in the ASO customer inbound message.  <b>Note:</b> The system refers the value from within the <b>headerData</b> tag.									
headerData	Used to indicate the transaction in the external source system which resulted in the ASO customer inbound message.									

Tag Name	Tag Description	Mandatory (Yes or No)						
externalBatchId	<p>You can use this tag within the following tags:</p> <table border="1" data-bbox="570 302 1190 884"> <thead> <tr> <th data-bbox="570 302 841 386">If this tag is used within...</th> <th data-bbox="841 302 1190 386">Then the purpose of the externalBatchId tag is...</th> </tr> </thead> <tbody> <tr> <td data-bbox="570 386 841 701">schema</td> <td data-bbox="841 386 1190 701">           Indicates the external batch job or batch run number through which the ASO customer inbound message is created.   <div data-bbox="854 569 1177 684" style="border: 1px solid black; padding: 2px;"> <b>Note:</b> The system refers the value from within the <b>headerData</b> tag.           </div> </td> </tr> <tr> <td data-bbox="570 701 841 884">headerData</td> <td data-bbox="841 701 1190 884">Used to indicate the external batch job or batch run number through which the ASO customer inbound message is created.</td> </tr> </tbody> </table>	If this tag is used within...	Then the purpose of the externalBatchId tag is...	schema	Indicates the external batch job or batch run number through which the ASO customer inbound message is created.  <div data-bbox="854 569 1177 684" style="border: 1px solid black; padding: 2px;"> <b>Note:</b> The system refers the value from within the <b>headerData</b> tag.           </div>	headerData	Used to indicate the external batch job or batch run number through which the ASO customer inbound message is created.	Yes
If this tag is used within...	Then the purpose of the externalBatchId tag is...							
schema	Indicates the external batch job or batch run number through which the ASO customer inbound message is created.  <div data-bbox="854 569 1177 684" style="border: 1px solid black; padding: 2px;"> <b>Note:</b> The system refers the value from within the <b>headerData</b> tag.           </div>							
headerData	Used to indicate the external batch job or batch run number through which the ASO customer inbound message is created.							
externalSourceId	<p>You can use this tag within the following tags:</p> <table border="1" data-bbox="570 974 1190 1346"> <thead> <tr> <th data-bbox="570 974 841 1058">If this tag is used within...</th> <th data-bbox="841 974 1190 1058">Then the purpose of the externalSourceId tag is...</th> </tr> </thead> <tbody> <tr> <td data-bbox="570 1058 841 1268">schema</td> <td data-bbox="841 1058 1190 1268">           Displays the external source system ID.   <div data-bbox="854 1136 1177 1251" style="border: 1px solid black; padding: 2px;"> <b>Note:</b> The system refers the value from within the <b>headerData</b> tag.           </div> </td> </tr> <tr> <td data-bbox="570 1268 841 1346">headerData</td> <td data-bbox="841 1268 1190 1346">Used to specify the external source system ID.</td> </tr> </tbody> </table>	If this tag is used within...	Then the purpose of the externalSourceId tag is...	schema	Displays the external source system ID.  <div data-bbox="854 1136 1177 1251" style="border: 1px solid black; padding: 2px;"> <b>Note:</b> The system refers the value from within the <b>headerData</b> tag.           </div>	headerData	Used to specify the external source system ID.	Yes
If this tag is used within...	Then the purpose of the externalSourceId tag is...							
schema	Displays the external source system ID.  <div data-bbox="854 1136 1177 1251" style="border: 1px solid black; padding: 2px;"> <b>Note:</b> The system refers the value from within the <b>headerData</b> tag.           </div>							
headerData	Used to specify the external source system ID.							

Tag Name	Tag Description	Mandatory (Yes or No)														
characteristics	<p>You can use this tag within the following tags:</p> <table border="1" data-bbox="570 302 1190 1005"> <thead> <tr> <th data-bbox="570 302 841 386">If this tag is used within...</th> <th data-bbox="841 302 1190 386">Then the purpose of the characteristics tag is...</th> </tr> </thead> <tbody> <tr> <td data-bbox="570 386 841 499">schema</td> <td data-bbox="841 386 1190 499">Used to specify a list of characteristics for the ASO customer inbound message.</td> </tr> <tr> <td data-bbox="570 499 841 613">parentCustomerData</td> <td data-bbox="841 499 1190 613">Used to specify a list of characteristics for the parent customer.</td> </tr> <tr> <td data-bbox="570 613 841 726">billGroupData</td> <td data-bbox="841 613 1190 726">Used to specify a list of characteristics for the bill group.</td> </tr> <tr> <td data-bbox="570 726 841 810">accountData</td> <td data-bbox="841 726 1190 810">Used to specify a list of characteristics for the account.</td> </tr> <tr> <td data-bbox="570 810 841 894">policyData</td> <td data-bbox="841 810 1190 894">Used to specify a list of characteristics for the policy.</td> </tr> <tr> <td data-bbox="570 894 841 1005">planData</td> <td data-bbox="841 894 1190 1005">Used to specify a list of characteristics for the policy plan.</td> </tr> </tbody> </table>	If this tag is used within...	Then the purpose of the characteristics tag is...	schema	Used to specify a list of characteristics for the ASO customer inbound message.	parentCustomerData	Used to specify a list of characteristics for the parent customer.	billGroupData	Used to specify a list of characteristics for the bill group.	accountData	Used to specify a list of characteristics for the account.	policyData	Used to specify a list of characteristics for the policy.	planData	Used to specify a list of characteristics for the policy plan.	No
If this tag is used within...	Then the purpose of the characteristics tag is...															
schema	Used to specify a list of characteristics for the ASO customer inbound message.															
parentCustomerData	Used to specify a list of characteristics for the parent customer.															
billGroupData	Used to specify a list of characteristics for the bill group.															
accountData	Used to specify a list of characteristics for the account.															
policyData	Used to specify a list of characteristics for the policy.															
planData	Used to specify a list of characteristics for the policy plan.															
inboundMessageCharacteristic	Used to specify a characteristic for the ASO customer inbound message.	No														
adhocCharacteristicValue	Used to specify the value for the adhoc characteristic type.	Yes (Conditional) <div data-bbox="1214 1167 1466 1377" style="border: 1px solid black; padding: 5px; margin-top: 10px;"> <p><b>Note:</b> This data is required while defining or editing an adhoc characteristic of the health care inbound message.</p> </div>														

Tag Name	Tag Description	Mandatory (Yes or No)						
characteristicType	<p>You can use this tag within the following tags:</p> <table border="1" data-bbox="570 302 1190 1892"> <thead> <tr> <th data-bbox="570 302 919 449">If this tag is used within...</th> <th data-bbox="919 302 1190 449">Then the purpose of the characteristicType tag is...</th> </tr> </thead> <tbody> <tr> <td data-bbox="570 449 919 722">inboundMessageCharacteristic</td> <td data-bbox="919 449 1190 722">Used to specify the characteristic type. Here, you must specify a characteristic type where the characteristic entity is set to <b>Inbound Message</b>.</td> </tr> <tr> <td data-bbox="570 722 919 1892">characteristicsList</td> <td data-bbox="919 722 1190 1892">           Used to specify the characteristic type. If you are defining a characteristic for a:           <ul style="list-style-type: none"> <li>• <b>Parent Customer</b> - You must specify a characteristic type where the characteristic entity is set to <b>Person</b>.</li> <li>• <b>Bill Group</b> - You must specify a characteristic type where the characteristic entity is set to <b>Person</b>.</li> <li>• <b>Account</b> - You must specify a characteristic type where the characteristic entity is set to <b>Account</b>.</li> <li>• <b>Policy</b> - You must specify a characteristic type where the characteristic entity is set to <b>Policy</b>.</li> </ul> </td> </tr> </tbody> </table>	If this tag is used within...	Then the purpose of the characteristicType tag is...	inboundMessageCharacteristic	Used to specify the characteristic type. Here, you must specify a characteristic type where the characteristic entity is set to <b>Inbound Message</b> .	characteristicsList	Used to specify the characteristic type. If you are defining a characteristic for a: <ul style="list-style-type: none"> <li>• <b>Parent Customer</b> - You must specify a characteristic type where the characteristic entity is set to <b>Person</b>.</li> <li>• <b>Bill Group</b> - You must specify a characteristic type where the characteristic entity is set to <b>Person</b>.</li> <li>• <b>Account</b> - You must specify a characteristic type where the characteristic entity is set to <b>Account</b>.</li> <li>• <b>Policy</b> - You must specify a characteristic type where the characteristic entity is set to <b>Policy</b>.</li> </ul>	<p>Yes (Conditional)</p> <div data-bbox="1214 296 1463 468" style="border: 1px solid black; padding: 5px;"> <p><b>Note:</b> This data is required while defining or editing a characteristic of the respective entity.</p> </div>
If this tag is used within...	Then the purpose of the characteristicType tag is...							
inboundMessageCharacteristic	Used to specify the characteristic type. Here, you must specify a characteristic type where the characteristic entity is set to <b>Inbound Message</b> .							
characteristicsList	Used to specify the characteristic type. If you are defining a characteristic for a: <ul style="list-style-type: none"> <li>• <b>Parent Customer</b> - You must specify a characteristic type where the characteristic entity is set to <b>Person</b>.</li> <li>• <b>Bill Group</b> - You must specify a characteristic type where the characteristic entity is set to <b>Person</b>.</li> <li>• <b>Account</b> - You must specify a characteristic type where the characteristic entity is set to <b>Account</b>.</li> <li>• <b>Policy</b> - You must specify a characteristic type where the characteristic entity is set to <b>Policy</b>.</li> </ul>							

Tag Name	Tag Description	Mandatory (Yes or No)						
	<table border="1"> <tr> <td data-bbox="570 254 919 543"></td> <td data-bbox="919 254 1190 543"> <ul style="list-style-type: none"> <li>• <b>Policy Plan</b> - You must specify a characteristic type where the characteristic entity is set to <b>Policy Plan</b>.</li> </ul> </td> </tr> </table>		<ul style="list-style-type: none"> <li>• <b>Policy Plan</b> - You must specify a characteristic type where the characteristic entity is set to <b>Policy Plan</b>.</li> </ul>					
	<ul style="list-style-type: none"> <li>• <b>Policy Plan</b> - You must specify a characteristic type where the characteristic entity is set to <b>Policy Plan</b>.</li> </ul>							
effectiveDate	<p>You can use this tag within the following tags:</p> <table border="1"> <thead> <tr> <th data-bbox="570 636 919 747">If this tag is used within...</th> <th data-bbox="919 636 1190 747">Then the purpose of the effectiveDate tag is...</th> </tr> </thead> <tbody> <tr> <td data-bbox="570 747 919 957">inboundMessageCharacteristic</td> <td data-bbox="919 747 1190 957">Used to specify the date from when the characteristic is effective for the ASO customer inbound message.</td> </tr> <tr> <td data-bbox="570 957 919 1230">characteristicsList</td> <td data-bbox="919 957 1190 1230">Used to specify the date from when the characteristic is effective for the respective entity (i.e. parent customer, bill group, account, policy, or policy plan).</td> </tr> </tbody> </table> <p><b>Note:</b> You must specify the date in the YYYY-MM-DD format.</p>	If this tag is used within...	Then the purpose of the effectiveDate tag is...	inboundMessageCharacteristic	Used to specify the date from when the characteristic is effective for the ASO customer inbound message.	characteristicsList	Used to specify the date from when the characteristic is effective for the respective entity (i.e. parent customer, bill group, account, policy, or policy plan).	<p>Yes (Conditional)</p> <p><b>Note:</b> This data is required while defining or editing a characteristic of the respective entity.</p>
If this tag is used within...	Then the purpose of the effectiveDate tag is...							
inboundMessageCharacteristic	Used to specify the date from when the characteristic is effective for the ASO customer inbound message.							
characteristicsList	Used to specify the date from when the characteristic is effective for the respective entity (i.e. parent customer, bill group, account, policy, or policy plan).							
characteristicValue	<p>You can use this tag within the following tags:</p> <table border="1"> <thead> <tr> <th data-bbox="570 1423 919 1570">If this tag is used within...</th> <th data-bbox="919 1423 1190 1570">Then the purpose of the characteristicValue tag is...</th> </tr> </thead> <tbody> <tr> <td data-bbox="570 1570 919 1682">inboundMessageCharacteristic</td> <td data-bbox="919 1570 1190 1682">Used to specify the value for the predefined characteristic type.</td> </tr> <tr> <td data-bbox="570 1682 919 1793">characteristicsList</td> <td data-bbox="919 1682 1190 1793">Used to specify the value for the characteristic type.</td> </tr> </tbody> </table>	If this tag is used within...	Then the purpose of the characteristicValue tag is...	inboundMessageCharacteristic	Used to specify the value for the predefined characteristic type.	characteristicsList	Used to specify the value for the characteristic type.	<p>Yes (Conditional)</p> <p><b>Note:</b> This data is required while defining or editing a characteristic of the respective entity.</p>
If this tag is used within...	Then the purpose of the characteristicValue tag is...							
inboundMessageCharacteristic	Used to specify the value for the predefined characteristic type.							
characteristicsList	Used to specify the value for the characteristic type.							

Tag Name	Tag Description	Mandatory (Yes or No)								
characteristicValueForeignKey	Used to specify the first value for the foreign key characteristic type.	Yes (Conditional) <b>Note:</b> This data is required while defining or editing a foreign key characteristic of the health care inbound message.								
characteristicValueFK2	Used to specify the second value for the foreign key characteristic type.	No								
characteristicValueFK3	Used to specify the third value for the foreign key characteristic type.	No								
characteristicValueFK4	Used to specify the fourth value for the foreign key characteristic type.	No								
characteristicValueFK5	Used to specify the fifth value for the foreign key characteristic type.	No								
customerStructureMessage	Used to specify the details of the customer including the header information for the ASO customer inbound message.	Yes								
headerData	Used to specify the header information for the ASO customer inbound message.	Yes								
parentCustomerData	Used to specify the details of the parent customer.	Yes								
parentCustomerName	Used to specify the name of the parent customer.	Yes (Conditional) <b>Note:</b> This data is required while defining a parent customer.								
division	<p>You can use this tag within the following tags:</p> <table border="1"> <thead> <tr> <th>If this tag is used within...</th> <th>Then the purpose of the division tag is...</th> </tr> </thead> <tbody> <tr> <td>parentCustomerData</td> <td>Used to indicate the division to which the parent customer belongs.</td> </tr> <tr> <td>billGroupData</td> <td>Used to indicate the division to which the bill group belongs.</td> </tr> <tr> <td>accountData</td> <td>Used to indicate the division to which the account belongs.</td> </tr> </tbody> </table> <p><b>Note:</b> You must specify a division which is already defined in the system.</p>	If this tag is used within...	Then the purpose of the division tag is...	parentCustomerData	Used to indicate the division to which the parent customer belongs.	billGroupData	Used to indicate the division to which the bill group belongs.	accountData	Used to indicate the division to which the account belongs.	No
If this tag is used within...	Then the purpose of the division tag is...									
parentCustomerData	Used to indicate the division to which the parent customer belongs.									
billGroupData	Used to indicate the division to which the bill group belongs.									
accountData	Used to indicate the division to which the account belongs.									

Tag Name	Tag Description	Mandatory (Yes or No)								
identifiers	<p>You can use this tag within the following tags:</p> <table border="1" data-bbox="570 302 1190 726"> <thead> <tr> <th data-bbox="570 302 911 386">If this tag is used within...</th> <th data-bbox="911 302 1190 386">Then the purpose of the identifiers tag is...</th> </tr> </thead> <tbody> <tr> <td data-bbox="570 386 911 499">parentCustomerData</td> <td data-bbox="911 386 1190 499">Used to specify the identification details for the parent customer.</td> </tr> <tr> <td data-bbox="570 499 911 613">billGroupData</td> <td data-bbox="911 499 1190 613">Used to specify the identification details for the bill group.</td> </tr> <tr> <td data-bbox="570 613 911 726">accountData</td> <td data-bbox="911 613 1190 726">Used to specify the identification details for the account.</td> </tr> </tbody> </table> <p><b>Note:</b> You must specify one primary identifier for a person and account.</p>	If this tag is used within...	Then the purpose of the identifiers tag is...	parentCustomerData	Used to specify the identification details for the parent customer.	billGroupData	Used to specify the identification details for the bill group.	accountData	Used to specify the identification details for the account.	<p>Yes (Conditional)</p> <p><b>Note:</b> This data is required while defining or editing the respective information.</p>
If this tag is used within...	Then the purpose of the identifiers tag is...									
parentCustomerData	Used to specify the identification details for the parent customer.									
billGroupData	Used to specify the identification details for the bill group.									
accountData	Used to specify the identification details for the account.									
idType	<p>You can use this tag within the following tags:</p> <table border="1" data-bbox="570 917 1190 1283"> <thead> <tr> <th data-bbox="570 917 911 1001">If this tag is used within...</th> <th data-bbox="911 917 1190 1001">Then the purpose of the idType tag is...</th> </tr> </thead> <tbody> <tr> <td data-bbox="570 1001 911 1115">identifiers</td> <td data-bbox="911 1001 1190 1115">Used to specify the person or account identifier type.</td> </tr> <tr> <td data-bbox="570 1115 911 1199">relatedPersons</td> <td data-bbox="911 1115 1190 1199">Used to specify the person identifier type.</td> </tr> <tr> <td data-bbox="570 1199 911 1283">policyPersons</td> <td data-bbox="911 1199 1190 1283">Used to specify the person identifier type.</td> </tr> </tbody> </table> <p><b>Note:</b> You must specify an identifier type which is already defined in the system.</p>	If this tag is used within...	Then the purpose of the idType tag is...	identifiers	Used to specify the person or account identifier type.	relatedPersons	Used to specify the person identifier type.	policyPersons	Used to specify the person identifier type.	<p>Yes (Conditional)</p> <p><b>Note:</b> This data is required in the following scenarios:</p> <ul style="list-style-type: none"> <li>• While defining or editing the identification details of a parent customer, bill group, and account.</li> <li>• While defining or editing a person to person relationship.</li> <li>• While associating a person with a policy.</li> </ul>
If this tag is used within...	Then the purpose of the idType tag is...									
identifiers	Used to specify the person or account identifier type.									
relatedPersons	Used to specify the person identifier type.									
policyPersons	Used to specify the person identifier type.									



Tag Name	Tag Description	Mandatory (Yes or No)								
idValue	<p>You can use this tag within the following tags:</p> <table border="1" data-bbox="570 302 1190 758"> <thead> <tr> <th data-bbox="570 302 907 380">If this tag is used within...</th> <th data-bbox="907 302 1190 380">Then the purpose of the idValue tag is...</th> </tr> </thead> <tbody> <tr> <td data-bbox="570 380 907 495">identifiers</td> <td data-bbox="907 380 1190 495">Used to specify the person or account identifier.</td> </tr> <tr> <td data-bbox="570 495 907 611">relatedPersons</td> <td data-bbox="907 495 1190 611">Used to indicate the person who is related to the parent customer.</td> </tr> <tr> <td data-bbox="570 611 907 758">policyPersons</td> <td data-bbox="907 611 1190 758">Used to indicate the person to whom you want to associate the policy.</td> </tr> </tbody> </table>	If this tag is used within...	Then the purpose of the idValue tag is...	identifiers	Used to specify the person or account identifier.	relatedPersons	Used to indicate the person who is related to the parent customer.	policyPersons	Used to indicate the person to whom you want to associate the policy.	<p>Yes (Conditional)</p> <p><b>Note:</b> This data is required while defining or editing the respective information.</p>
If this tag is used within...	Then the purpose of the idValue tag is...									
identifiers	Used to specify the person or account identifier.									
relatedPersons	Used to indicate the person who is related to the parent customer.									
policyPersons	Used to indicate the person to whom you want to associate the policy.									
isPrimary	<p>Used to indicate whether the person or account identifier is a primary identifier. The valid values are:</p> <ul style="list-style-type: none"> <li>• Y</li> <li>• N</li> </ul> <p><b>Note:</b> If you do not specify the value, by default, it is set to N.</p>	<p>No</p>								
address	<p>You can use this tag within the following tags:</p> <table border="1" data-bbox="570 1142 1190 1528"> <thead> <tr> <th data-bbox="570 1142 907 1220">If this tag is used within...</th> <th data-bbox="907 1142 1190 1220">Then the purpose of the address tag is...</th> </tr> </thead> <tbody> <tr> <td data-bbox="570 1220 907 1335">parentCustomerData</td> <td data-bbox="907 1220 1190 1335">Used to specify the address of the parent customer.</td> </tr> <tr> <td data-bbox="570 1335 907 1451">billGroupData</td> <td data-bbox="907 1335 1190 1451">Used to specify the address of the bill group.</td> </tr> <tr> <td data-bbox="570 1451 907 1528">accountData</td> <td data-bbox="907 1451 1190 1528">Used to specify the address of the account.</td> </tr> </tbody> </table>	If this tag is used within...	Then the purpose of the address tag is...	parentCustomerData	Used to specify the address of the parent customer.	billGroupData	Used to specify the address of the bill group.	accountData	Used to specify the address of the account.	<p>Yes (Conditional)</p> <p><b>Note:</b> This data is required while defining or editing the address of the respective entity.</p>
If this tag is used within...	Then the purpose of the address tag is...									
parentCustomerData	Used to specify the address of the parent customer.									
billGroupData	Used to specify the address of the bill group.									
accountData	Used to specify the address of the account.									
addressEffDate	<p>Used to specify the date from when the address is effective.</p> <p><b>Note:</b> You must specify the date in the YYYY-MM-DD format. If you do not specify the date, by default, the system sets the effective date to the date when the address is created in the system through the ASO customer inbound message.</p>	<p>Yes (Conditional)</p> <p><b>Note:</b> This data is required while editing the address of a person or account.</p>								

Tag Name	Tag Description	Mandatory (Yes or No)
addressType	<p>Used to indicate the type of address. The valid values are:</p> <ul style="list-style-type: none"> <li>• <b>MAIN</b> - Indicates that the address is the person's mailing address. You can use this address type while specifying the address for the person and account.</li> <li>• <b>SEAS</b> - Indicates that the address is the person's seasonal address. You can use this address type while specifying the address for the person.</li> <li>• <b>OVRD</b> - Indicates that the address is the account's override address. You can use this address type while specifying the address for the account.</li> </ul> <p><b>Note:</b> If you do not specify the address type, by default, it is set to <b>MAIN</b>. You must specify an address type which is already defined in the <b>ADDRESS_TYPE_FLG</b> lookup field. It must be in the <b>Active</b> status.</p>	<p>Yes (Conditional)</p> <p><b>Note:</b> This data is required while editing the address of a person or account.</p>
mailingName	Used to specify the name using which the parent customer or bill group should be addressed in the mail communication. The system also uses the mailing name in the bills, letters, quotes, and statements.	No
address1	Used to specify the first line of the address. It may contain details, such as the house number.	<p>Yes (Conditional)</p> <p><b>Note:</b> This data is required while defining and editing the address of a person and account.</p>
address2	Used to specify the second line of the address. It may contain details, such as the apartment name.	No
address3	Used to specify the third line of the address. It may contain details, such as the street name.	No
attentionName	Used to specify the fourth line of the address. It may contain the landmark details.	No
city	Used to specify the city name.	No
state	Used to indicate the state where the city is located.	No
zip	Used to specify the zip code of the address.	No
country	Used to indicate the country where the parent customer, bill group, or account is located.	<p>Yes (Conditional)</p> <p><b>Note:</b> This data is required while defining or editing the address of a person or account.</p>

Tag Name	Tag Description	Mandatory (Yes or No)						
email	<p>You can use this tag within the following tags:</p> <table border="1" data-bbox="570 302 1190 615"> <thead> <tr> <th data-bbox="570 302 907 386">If this tag is used within...</th> <th data-bbox="907 302 1190 386">Then the purpose of the email tag is...</th> </tr> </thead> <tbody> <tr> <td data-bbox="570 386 907 499">parentCustomerData</td> <td data-bbox="907 386 1190 499">Used to specify the e-mail ID of the parent customer.</td> </tr> <tr> <td data-bbox="570 499 907 615">billGroupData</td> <td data-bbox="907 499 1190 615">Used to specify the e-mail ID of the bill group.</td> </tr> </tbody> </table>	If this tag is used within...	Then the purpose of the email tag is...	parentCustomerData	Used to specify the e-mail ID of the parent customer.	billGroupData	Used to specify the e-mail ID of the bill group.	No
If this tag is used within...	Then the purpose of the email tag is...							
parentCustomerData	Used to specify the e-mail ID of the parent customer.							
billGroupData	Used to specify the e-mail ID of the bill group.							
phones	<p>You can use this tag within the following tags:</p> <table border="1" data-bbox="570 705 1190 1018"> <thead> <tr> <th data-bbox="570 705 907 789">If this tag is used within...</th> <th data-bbox="907 705 1190 789">Then the purpose of the phones tag is...</th> </tr> </thead> <tbody> <tr> <td data-bbox="570 789 907 903">parentCustomerData</td> <td data-bbox="907 789 1190 903">Used to specify the phone details of the parent customer.</td> </tr> <tr> <td data-bbox="570 903 907 1018">billGroupData</td> <td data-bbox="907 903 1190 1018">Used to specify the phone details of the bill group.</td> </tr> </tbody> </table>	If this tag is used within...	Then the purpose of the phones tag is...	parentCustomerData	Used to specify the phone details of the parent customer.	billGroupData	Used to specify the phone details of the bill group.	<p>Yes (Conditional)</p> <div data-bbox="1214 695 1466 842" style="border: 1px solid black; padding: 2px;"> <p><b>Note:</b> This data is required while defining or editing the phone details of a person.</p> </div>
If this tag is used within...	Then the purpose of the phones tag is...							
parentCustomerData	Used to specify the phone details of the parent customer.							
billGroupData	Used to specify the phone details of the bill group.							
phoneType	<p>Used to indicate the type of phone.</p> <div data-bbox="570 1098 1190 1178" style="border: 1px solid black; padding: 2px;"> <p><b>Note:</b> You must specify a phone type which is already defined in the system.</p> </div>	<p>Yes (Conditional)</p> <div data-bbox="1214 1098 1466 1245" style="border: 1px solid black; padding: 2px;"> <p><b>Note:</b> This data is required while defining or editing the phone details of a person.</p> </div>						
phoneValue	<p>Used to specify the phone number of the parent customer or bill group.</p>	<p>Yes (Conditional)</p> <div data-bbox="1214 1325 1466 1472" style="border: 1px solid black; padding: 2px;"> <p><b>Note:</b> This data is required while defining or editing the phone details of a person.</p> </div>						
relatedPersons	<p>Used to list persons with whom you want to establish the parent customer's relationship.</p>	<p>Yes (Conditional)</p> <div data-bbox="1214 1547 1466 1694" style="border: 1px solid black; padding: 2px;"> <p><b>Note:</b> This data is required while defining or editing a person to person relationship.</p> </div>						
personRelationshipType	<p>Used to indicate how the person is related to the parent customer.</p> <div data-bbox="570 1799 1190 1879" style="border: 1px solid black; padding: 2px;"> <p><b>Note:</b> You must specify a person relationship type which is already defined in the system.</p> </div>	<p>Yes (Conditional)</p> <div data-bbox="1214 1770 1466 1917" style="border: 1px solid black; padding: 2px;"> <p><b>Note:</b> This data is required while creating a person to person relationship.</p> </div>						

Tag Name	Tag Description	Mandatory (Yes or No)														
startDate	<p>You can use this tag within the following tags:</p> <table border="1" data-bbox="570 302 1190 1129"> <thead> <tr> <th data-bbox="570 302 857 386">If this tag is used within...</th> <th data-bbox="857 302 1190 386">Then the purpose of the startDate tag is...</th> </tr> </thead> <tbody> <tr> <td data-bbox="570 386 857 531">relatedPersons</td> <td data-bbox="857 386 1190 531">Used to specify the date from when the person is related to the parent customer.</td> </tr> <tr> <td data-bbox="570 531 857 676">billGroupData</td> <td data-bbox="857 531 1190 676">Used to specify the date from when the bill group is related to the parent customer.</td> </tr> <tr> <td data-bbox="570 676 857 789">autoPayDetails</td> <td data-bbox="857 676 1190 789">Used to specify the date from when the auto pay instruction is effective.</td> </tr> <tr> <td data-bbox="570 789 857 903">policyData</td> <td data-bbox="857 789 1190 903">Used to specify the date from when the policy is effective.</td> </tr> <tr> <td data-bbox="570 903 857 1016">policyPersons</td> <td data-bbox="857 903 1190 1016">Used to specify the date from when the person is associated with the policy.</td> </tr> <tr> <td data-bbox="570 1016 857 1129">planData</td> <td data-bbox="857 1016 1190 1129">Used to specify the date from when the policy plan is effective.</td> </tr> </tbody> </table> <p data-bbox="570 1161 1190 1234"><b>Note:</b> You must specify the date in the YYYY-MM-DD format.</p>	If this tag is used within...	Then the purpose of the startDate tag is...	relatedPersons	Used to specify the date from when the person is related to the parent customer.	billGroupData	Used to specify the date from when the bill group is related to the parent customer.	autoPayDetails	Used to specify the date from when the auto pay instruction is effective.	policyData	Used to specify the date from when the policy is effective.	policyPersons	Used to specify the date from when the person is associated with the policy.	planData	Used to specify the date from when the policy plan is effective.	<p>Yes (Conditional)</p> <p data-bbox="1214 296 1464 432"><b>Note:</b> This data is required while defining or editing the respective information.</p>
If this tag is used within...	Then the purpose of the startDate tag is...															
relatedPersons	Used to specify the date from when the person is related to the parent customer.															
billGroupData	Used to specify the date from when the bill group is related to the parent customer.															
autoPayDetails	Used to specify the date from when the auto pay instruction is effective.															
policyData	Used to specify the date from when the policy is effective.															
policyPersons	Used to specify the date from when the person is associated with the policy.															
planData	Used to specify the date from when the policy plan is effective.															

Tag Name	Tag Description	Mandatory (Yes or No)														
endDate	<p>You can use this tag within the following tags:</p> <table border="1" data-bbox="570 302 1190 1037"> <thead> <tr> <th data-bbox="570 302 859 386">If this tag is used within...</th> <th data-bbox="859 302 1190 386">Then the purpose of the endDate tag is...</th> </tr> </thead> <tbody> <tr> <td data-bbox="570 386 859 499">relatedPersons</td> <td data-bbox="859 386 1190 499">Used to specify the date till when the person is related to the parent customer.</td> </tr> <tr> <td data-bbox="570 499 859 613">billGroupData</td> <td data-bbox="859 499 1190 613">Used to specify the date till when the bill group is related to the parent customer.</td> </tr> <tr> <td data-bbox="570 613 859 726">autoPayDetails</td> <td data-bbox="859 613 1190 726">Used to specify the date till when the auto pay instruction is effective.</td> </tr> <tr> <td data-bbox="570 726 859 810">policyData</td> <td data-bbox="859 726 1190 810">Used to specify the date till when the policy is effective.</td> </tr> <tr> <td data-bbox="570 810 859 921">policyPersons</td> <td data-bbox="859 810 1190 921">Used to specify the date till when the person is associated with the policy.</td> </tr> <tr> <td data-bbox="570 921 859 1037">planData</td> <td data-bbox="859 921 1190 1037">Used to specify the date till when the policy plan is effective.</td> </tr> </tbody> </table> <p data-bbox="570 1062 1190 1142"><b>Note:</b> You must specify the date in the YYYY-MM-DD format.</p>	If this tag is used within...	Then the purpose of the endDate tag is...	relatedPersons	Used to specify the date till when the person is related to the parent customer.	billGroupData	Used to specify the date till when the bill group is related to the parent customer.	autoPayDetails	Used to specify the date till when the auto pay instruction is effective.	policyData	Used to specify the date till when the policy is effective.	policyPersons	Used to specify the date till when the person is associated with the policy.	planData	Used to specify the date till when the policy plan is effective.	No
If this tag is used within...	Then the purpose of the endDate tag is...															
relatedPersons	Used to specify the date till when the person is related to the parent customer.															
billGroupData	Used to specify the date till when the bill group is related to the parent customer.															
autoPayDetails	Used to specify the date till when the auto pay instruction is effective.															
policyData	Used to specify the date till when the policy is effective.															
policyPersons	Used to specify the date till when the person is associated with the policy.															
planData	Used to specify the date till when the policy plan is effective.															

Tag Name	Tag Description	Mandatory (Yes or No)						
financialRelationshipSw	<p>You can use this tag within the following tags:</p> <table border="1" data-bbox="570 302 1190 978"> <thead> <tr> <th data-bbox="570 302 857 415">If this tag is used within...</th> <th data-bbox="857 302 1190 415">Then the purpose of the financialRelationshipSw tag is...</th> </tr> </thead> <tbody> <tr> <td data-bbox="570 415 857 699">relatedPersons</td> <td data-bbox="857 415 1190 699">           Used to indicate whether the related person is financially responsible for the parent customer. The valid values are:           <ul style="list-style-type: none"> <li>• true</li> <li>• false</li> </ul> </td> </tr> <tr> <td data-bbox="570 699 857 978">billGroupData</td> <td data-bbox="857 699 1190 978">           Used to indicate whether the bill group is financially responsible for the parent customer. The valid values are:           <ul style="list-style-type: none"> <li>• true</li> <li>• false</li> </ul> </td> </tr> </tbody> </table> <p><b>Note:</b> If you do not specify the value, by default, it is set to <b>false</b>.</p>	If this tag is used within...	Then the purpose of the financialRelationshipSw tag is...	relatedPersons	Used to indicate whether the related person is financially responsible for the parent customer. The valid values are: <ul style="list-style-type: none"> <li>• true</li> <li>• false</li> </ul>	billGroupData	Used to indicate whether the bill group is financially responsible for the parent customer. The valid values are: <ul style="list-style-type: none"> <li>• true</li> <li>• false</li> </ul>	No
If this tag is used within...	Then the purpose of the financialRelationshipSw tag is...							
relatedPersons	Used to indicate whether the related person is financially responsible for the parent customer. The valid values are: <ul style="list-style-type: none"> <li>• true</li> <li>• false</li> </ul>							
billGroupData	Used to indicate whether the bill group is financially responsible for the parent customer. The valid values are: <ul style="list-style-type: none"> <li>• true</li> <li>• false</li> </ul>							
characteristicsList	Used to specify a characteristic for the respective entity (i.e. parent customer, bill group, account, policy, or policy plan).	Yes (Conditional) <p><b>Note:</b> This data is required while defining or editing a characteristic of the respective entity.</p>						
billGroupData	Used to specify the details of the bill group.	Yes (Conditional) <p><b>Note:</b> This data is required while defining or editing a bill group.</p>						
seqNo	Used to indicate the order in which the bill group should be created in the system.	Yes (Conditional) <p><b>Note:</b> This data is required while defining or editing a bill group.</p>						
billGroupName	Used to specify the name of the bill group.	Yes (Conditional) <p><b>Note:</b> This data is required while defining a bill group.</p>						

Tag Name	Tag Description	Mandatory (Yes or No)																
accountData	<p>Used to specify the account details of the bill group.</p> <p><b>Note:</b> The system, by default, adds the bill group (for whom the account information is given in the ASO customer inbound message) as the main customer of the account. While linking the bill group as main customer of the account, the system sets the following attributes:</p> <table border="1" data-bbox="570 527 1190 909"> <thead> <tr> <th data-bbox="570 527 919 575">Attribute Name</th> <th data-bbox="919 527 1190 575">Attribute Value</th> </tr> </thead> <tbody> <tr> <td data-bbox="570 575 919 625">Financially Responsible</td> <td data-bbox="919 575 1190 625">Y</td> </tr> <tr> <td data-bbox="570 625 919 676">Account Relationship Type</td> <td data-bbox="919 625 1190 676">Main Customer</td> </tr> <tr> <td data-bbox="570 676 919 726">Receive Copy of Bill</td> <td data-bbox="919 676 1190 726">Y</td> </tr> <tr> <td data-bbox="570 726 919 777">Bill Format</td> <td data-bbox="919 726 1190 777">Detailed</td> </tr> <tr> <td data-bbox="570 777 919 827">Receives Notification</td> <td data-bbox="919 777 1190 827">Y</td> </tr> <tr> <td data-bbox="570 827 919 877">Number of Bill Copies</td> <td data-bbox="919 827 1190 877">1</td> </tr> <tr> <td data-bbox="570 877 919 909"></td> <td data-bbox="919 877 1190 909"></td> </tr> </tbody> </table>	Attribute Name	Attribute Value	Financially Responsible	Y	Account Relationship Type	Main Customer	Receive Copy of Bill	Y	Bill Format	Detailed	Receives Notification	Y	Number of Bill Copies	1			<p>Yes (Conditional)</p> <p><b>Note:</b> This data is required while defining or editing an account.</p>
Attribute Name	Attribute Value																	
Financially Responsible	Y																	
Account Relationship Type	Main Customer																	
Receive Copy of Bill	Y																	
Bill Format	Detailed																	
Receives Notification	Y																	
Number of Bill Copies	1																	
accountType	<p>Used to indicate the type of account. This information is stored as a characteristic for the account.</p> <p><b>Note:</b> The value is stored in the characteristic type which is specified in the <b>Invoice Type Characteristic Type</b> option type of the <b>C1-ASOBLNG</b> feature configuration. You must specify a value which is already defined in the predefined characteristic type.</p>	<p>Yes (Conditional)</p> <p><b>Note:</b> This data is required while defining or editing an account.</p>																
customerClass	<p>Used to indicate the customer class to which the account belongs.</p> <p><b>Note:</b> You must specify a customer class which is already defined in the system.</p>	<p>Yes (Conditional)</p> <p><b>Note:</b> This data is required while defining an account.</p>																
billCycle	<p>Used to indicate the bill cycle for the account.</p> <p><b>Note:</b> You must specify a bill cycle which is already defined in the system.</p>	<p>No</p>																
billRouteType	<p>Used to indicate how the account's bill must be sent to the main customer.</p> <p><b>Note:</b> You must specify a bill route type which is already defined in the system.</p>	<p>Yes (Conditional)</p> <p><b>Note:</b> This data is required while defining the bill routing information for the main customer.</p>																

Tag Name	Tag Description	Mandatory (Yes or No)
billAddressSource	Used to indicate whether the account's bill must be sent to the main customer's mailing address or to the main customer's account override address. The valid values are: <ul style="list-style-type: none"> <li>• PER</li> <li>• ACOV</li> </ul>	Yes (Conditional) <b>Note:</b> This data is required while defining the bill routing information for the main customer.
autoPayDetails	Used to specify the auto pay instruction for the account.	Yes (Conditional) <b>Note:</b> This data is required while defining or editing an auto pay instruction of an account.
priority	Used to indicate the priority in which the auto pay instruction should be considered when multiple auto pay instructions are effective on the bill's due date. <b>Note:</b> The priority cannot be less than or equal to zero.	Yes (Conditional) <b>Note:</b> This data is required while defining or editing an auto pay instruction of an account.
percentage	Used to indicate the percentage in which the payment must be split between two or more auto pay sources having the same priority.	Yes (Conditional) <b>Note:</b> This data is required while defining or editing the split auto pay instruction for an account.
autoPayMethod	Used to indicate how you want to process the automatic payment request. The valid values are: <ul style="list-style-type: none"> <li>• <b>C1DD</b> - Indicates that you want to directly debit the main customer's bank account.</li> <li>• <b>C1PA</b> - Indicates that you want to send a payment advice to the main customer.</li> </ul>	No
autoPayRouteType	Used to indicate when and how automatic payment request of the account is routed to a financial institution. <b>Note:</b> You must specify an auto pay route type which is already defined in the system.	Yes (Conditional) <b>Note:</b> This data is required while defining or editing an auto pay instruction of an account.



Tag Name	Tag Description	Mandatory (Yes or No)
autoPaySourceCode	<p>Used to indicate the financial institution that receives the automatic payment request.</p> <p><b>Note:</b> You must specify an auto pay source which is already defined in the system.</p>	<p>Yes (Conditional)</p> <p><b>Note:</b> This data is required while defining or editing an auto pay instruction of an account.</p>
accountNumber	<p>Used to indicate the bank account number through which the automatic payment must be done.</p>	<p>Yes (Conditional)</p> <p><b>Note:</b> This data is required while defining or editing an auto pay instruction of an account.</p>
expiryMonth	<p>Used to specify the month when the tender type of the auto pay source will expire.</p> <p><b>Note:</b> You must specify the month in the MM format.</p>	<p>Yes (Conditional)</p> <p><b>Note:</b> This data is required when the <b>Expiration Date Required</b> option is selected for the tender type which is specified in the auto pay source.</p>
expiryYear	<p>Used to specify the year when the tender type of the auto pay source will expire.</p> <p><b>Note:</b> You must specify the year in the YYYY format.</p>	<p>Yes (Conditional)</p> <p><b>Note:</b> This data is required when the <b>Expiration Date Required</b> option is selected for the tender type which is specified in the auto pay source.</p>
name	<p>Used to specify the name of the person as it appears in the financial institution's system.</p>	No
maxWithdrawalAmount	<p>Used to specify the maximum amount that can be automatically debited from the bank account. It is used to set the limit on the withdrawal amount.</p> <p><b>Note:</b> The maximum withdrawal amount cannot be less than zero.</p>	No
comments	<p>Used to specify additional information about the auto pay instruction.</p>	No

Tag Name	Tag Description	Mandatory (Yes or No)
policyData	Used to specify the details of the self-funded policy.	Yes (Conditional)  <b>Note:</b> This data is required while defining or editing a self-funded policy.
policyNumber	Used to specify the policy number.	Yes (Conditional)  <b>Note:</b> This data is required while defining or editing a self-funded policy.
policyDescription	Used to specify the description for the self-funded policy	Yes (Conditional)  <b>Note:</b> This data is required while defining a self-funded policy.
runOutEndDate	Used to specify the date when the runout period of the self-funded policy ends.  <b>Note:</b> The runout end date cannot be earlier than the policy end date. You must specify the date in the YYYY-MM-DD format.	No
runOutAdminOption	Used to indicate whether the administration fees must be charged when the claim transaction for the self-funded policy is processed in the runout period. The valid values are: <ul style="list-style-type: none"><li>• NROA</li><li>• PERC</li></ul> <b>Note:</b> At present, this data is used only for the information purposes and is not considered during the billable charge creation for the claim transactions which are received in the runout period of the policy. You must specify a value which is already defined in the <b>RUNOUT_ADM_OPT_FLG</b> lookup field. It must be in the <b>Active</b> status.	No

Tag Name	Tag Description	Mandatory (Yes or No)
policyPersons	Used to associate a person with the policy.	Yes (Conditional) <b>Note:</b> This data is required while associating a person with the policy.
policyPerRole	Used to indicate the role of the person in the policy. <b>Note:</b> You must specify a policy person role which is already defined in the system.	Yes (Conditional) <b>Note:</b> This data is required while associating a person with the policy.
planData	Used to specify the details of the policy plan.	Yes (Conditional) <b>Note:</b> This data is required while defining or editing a policy plan.
planNumber	Used to specify the plan number.	Yes (Conditional) <b>Note:</b> This data is required while defining or editing a policy plan.
planCode	Used to specify the price item which you want to associate with the policy plan. <b>Note:</b> You must specify a price item which is already defined in the system.	Yes (Conditional) <b>Note:</b> This data is required while defining or editing a policy plan.

The following table lists and describes the tags which are available in the ASO customer inbound message schema, but should not be included in the XML file:

Tag Name	Tag Description
InboundMessage	Displays the inbound message ID.
boStatus	Displays the status of the ASO customer inbound message.
statusReason	Indicates the reason why the status of the ASO customer inbound message is changed.
person	At present, this tag is not supported in an ASO customer inbound message.
statusDateTime	Displays the date and time when the status of the ASO customer inbound message is changed in the system.
creationDateTime	Displays the date and time when the ASO customer inbound message is created in the system.
searchCharacteristicValue	At present, this tag is not supported in an ASO customer inbound message.

Tag Name	Tag Description						
version	<p>This tag appears within the following parent tags:</p> <table border="1"> <thead> <tr> <th>Parent Tag</th> <th>Then the purpose of the version tag is...</th> </tr> </thead> <tbody> <tr> <td>schema</td> <td>Displays the version of the ASO customer inbound message.</td> </tr> <tr> <td>inboundMessageCharacteristic</td> <td>Displays the version of the characteristic defined for the ASO customer inbound message.</td> </tr> </tbody> </table>	Parent Tag	Then the purpose of the version tag is...	schema	Displays the version of the ASO customer inbound message.	inboundMessageCharacteristic	Displays the version of the characteristic defined for the ASO customer inbound message.
Parent Tag	Then the purpose of the version tag is...						
schema	Displays the version of the ASO customer inbound message.						
inboundMessageCharacteristic	Displays the version of the characteristic defined for the ASO customer inbound message.						
toDoRetry	<p>Displays the information about the retry option used for the ASO customer inbound message.</p> <p><b>Note:</b> This information appears at the bottom of the inbound message in the <b>Inbound Message Content</b> zone once the ASO customer inbound message is validated and processed either through the user interface or batch process.</p>						
retryDateTime	Displays the date and time when the retry option is used to change the status of the ASO customer inbound message from <b>Rejected</b> to <b>Pending</b> .						
numberOfRetries	Indicates the number of times the retry option is used for the ASO customer inbound message.						
currentErrorState	<p>Indicates the status to which the ASO customer inbound message is transitioned when its validation or processing fails. The valid value is:</p> <ul style="list-style-type: none"> <li>REJECTED</li> </ul>						
isRetried	<p>Indicates whether the retry option is used to change the status of the ASO customer inbound message. The valid values are:</p> <ul style="list-style-type: none"> <li>true</li> <li>false</li> </ul>						

### Related Topics

For more information on...	See...
ASO Customer Inbound Message Schema	<a href="#">ASO Customer Inbound Message Schema</a> on page 1852
Sample ASO Customer Inbound Message	<a href="#">Sample ASO Customer Inbound Message</a> on page 1856
How to setup the C1-ASOBLNG feature configuration	<a href="#">Setting the C1-ASOBLNG Feature Configuration</a> on page 2889

## ASO Customer Inbound Message Schema

```
<schema>
  <clInboundMessage></clInboundMessage>
  <bo></bo>
  <boStatus></boStatus>
  <statusReason></statusReason>
  <messageType></messageType>
```

```

<sourceSystem></sourceSystem>
<externalTransactionId></externalTransactionId>
<externalBatchId></externalBatchId>
<externalSourceId></externalSourceId>
<person></person>
<statusDateTime></statusDateTime>
<creationDateTime></creationDateTime>
<version></version>
<characteristics>
  <inboundMessageCharacteristic>
    <adhocCharacteristicValue></adhocCharacteristicValue>
    <characteristicType></characteristicType>
    <effectiveDate></effectiveDate>
    <characteristicValue></characteristicValue>
    <characteristicValueForeignKey1></characteristicValueForeignKey1>
    <characteristicValueFK2></characteristicValueFK2>
    <characteristicValueFK3></characteristicValueFK3>
    <characteristicValueFk4></characteristicValueFk4>
    <characteristicValueFK5></characteristicValueFK5>
    <searchCharacteristicValue></searchCharacteristicValue>
    <version></version>
  </inboundMessageCharacteristic>
</characteristics>
<customerStructureMessage>
  <headerData>
    <messageType></messageType>
    <sourceSystem></sourceSystem>
    <externalTransactionId></externalTransactionId>
    <externalBatchId></externalBatchId>
    <externalSourceId></externalSourceId>
  </headerData>
  <parentCustomerData>
    <parentCustomerName></parentCustomerName>
    <division></division>
    <identifiers>
      <idType></idType>
      <idValue></idValue>
      <isPrimary></isPrimary>
    </identifiers>
    <address>
      <addressEffDate></addressEffDate>
      <addressType></addressType>
      <mailingName></mailingName>
      <address1></address1>
      <address2></address2>
      <address3></address3>
      <attentionName></attentionName>
      <city></city>
      <state></state>
      <zip></zip>
      <country></country>
    </address>
    <email></email>
    <phones>
      <phoneType></phoneType>
      <phoneValue></phoneValue>
    </phones>
    <relatedPersons>
      <idType></idType>
      <idValue></idValue>
      <personRelationshipType></personRelationshipType>
      <startDate></startDate>
      <endDate></endDate>
      <financialRelationshipSw></financialRelationshipSw>
    </relatedPersons>
  </parentCustomerData>
</customerStructureMessage>

```

```

</relatedPersons>
<characteristics>
  <characteristicsList>
    <characteristicType></characteristicType>
    <characteristicValue></characteristicValue>
    <effectiveDate></effectiveDate>
  </characteristicsList>
</characteristics>
<billGroupData>
  <seqNo></seqNo>
  <billGroupName></billGroupName>
  <division></division>
  <startDate></startDate>
  <endDate></endDate>
  <financialRelationshipSw></financialRelationshipSw>
  <identifiers>
    <idType></idType>
    <idValue></idValue>
    <isPrimary></isPrimary>
  </identifiers>
  <address>
    <addressEffDate></addressEffDate>
    <addressType></addressType>
    <mailingName></mailingName>
    <address1></address1>
    <address2></address2>
    <address3></address3>
    <attentionName></attentionName>
    <city></city>
    <state></state>
    <zip></zip>
    <country></country>
  </address>
  <email></email>
  <phones>
    <phoneType></phoneType>
    <phoneValue></phoneValue>
  </phones>
  <characteristics>
    <characteristicsList>
      <characteristicType></characteristicType>
      <characteristicValue></characteristicValue>
      <effectiveDate></effectiveDate>
    </characteristicsList>
  </characteristics>
  <accountData>
    <accountType></accountType>
    <customerClass></customerClass>
    <billCycle></billCycle>
    <division></division>
    <billRouteType></billRouteType>
    <identifiers>
      <idType></idType>
      <idValue></idValue>
      <isPrimary></isPrimary>
    </identifiers>
    <billAddressSource></billAddressSource>
    <address>
      <addressEffDate></addressEffDate>
      <addressType></addressType>
      <address1></address1>
      <address2></address2>
      <address3></address3>
      <attentionName></attentionName>
    </address>
  </accountData>
</billGroupData>

```

```

        <city></city>
        <state></state>
        <zip></zip>
        <country></country>
    </address>
    <autoPayDetails>
        <priority></priority>
        <startDate></startDate>
        <endDate></endDate>
        <percentage></percentage>
        <autoPayMethod></autoPayMethod>
        <autoPayRouteType></autoPayRouteType>
        <autoPaySourceCode></autoPaySourceCode>
        <accountNumber></accountNumber>
        <expiryMonth></expiryMonth>
        <expiryYear></expiryYear>
        <name></name>
        <maxWithdrawalAmount></maxWithdrawalAmount>
        <comments></comments>
    </autoPayDetails>
    <characteristics>
        <characteristicsList>
            <characteristicType></characteristicType>
            <characteristicValue></characteristicValue>
            <effectiveDate></effectiveDate>
        </characteristicsList>
    </characteristics>
</accountData>
<policyData>
    <policyNumber></policyNumber>
    <sourceSystem></sourceSystem>
    <startDate></startDate>
    <endDate></endDate>
    <policyDescription></policyDescription>
    <runOutEndDate></runOutEndDate>
    <runOutAdminOption></runOutAdminOption>
    <policyPersons>
        <idType></idType>
        <idValue></idValue>
        <startDate></startDate>
        <endDate></endDate>
        <policyPerRole></policyPerRole>
    </policyPersons>
    <characteristics>
        <characteristicsList>
            <characteristicType></characteristicType>
            <characteristicValue></characteristicValue>
            <effectiveDate></effectiveDate>
        </characteristicsList>
    </characteristics>
    <planData>
        <planNumber></planNumber>
        <planCode></planCode>
        <startDate></startDate>
        <endDate></endDate>
        <characteristics>
            <characteristicsList>
                <characteristicType></characteristicType>
                <characteristicValue></characteristicValue>
                <effectiveDate></effectiveDate>
            </characteristicsList>
        </characteristics>
    </planData>
</policyData>

```

```

        </billGroupData>
      </parentCustomerData>
    </customerStructureMessage>
    <toDoRetry>
      <retryDateTime></retryDateTime>
      <numberOfRetries></numberOfRetries>
      <currentErrorState></currentErrorState>
      <isRetried></isRetried>
    </toDoRetry>
  </schema>

```

## Sample ASO Customer Inbound Message

Using the below example, you can do the following:

- Create the parent customer and bill groups for the self-funded health care business
- Create the accounts for the bill groups
- Create the self-funded policies for the bill groups

Parent Customer	Bill Group	Account	Policy
UK OIL AND GAS CORP	UK OIL AND GAS ACRE	Standard	Active Employee Health Care Policy
		Retention	Retiree Employee Health Care Policy
	UK OIL AND GAS COBRA	Standard	Active COBRA Employee Health Care Policy
		Retention	Retiree COBRA Employee Health Care Policy

```

<schema>
  <bo>C1-ASOCustomerInboundMessage</bo>
  <characteristics>
    <inboundMessageCharacteristic>
      <adhocCharacteristicValue></adhocCharacteristicValue>
      <characteristicType>C1-EXTBTCT</characteristicType>
      <effectiveDate>2019-01-01</effectiveDate>
      <characteristicValue>DATAEXT4</characteristicValue>
      <characteristicValueForeignKey1></characteristicValueForeignKey1>
      <characteristicValueFK2></characteristicValueFK2>
      <characteristicValueFK3></characteristicValueFK3>
      <characteristicValueFk4></characteristicValueFk4>
      <characteristicValueFK5></characteristicValueFK5>
    </inboundMessageCharacteristic>
  </characteristics>
  <customerStructureMessage>
    <headerData>
      <messageType>C1-ASO-CUSTOMER-INB-MSG-TYPE</messageType>
      <sourceSystem>SMALLPRIME</sourceSystem>
      <externalTransactionId>675380</externalTransactionId>
      <externalBatchId>898663</externalBatchId>
      <externalSourceId>656565</externalSourceId>
    </headerData>
    <parentCustomerData>
      <parentCustomerName>UK OIL AND GAS CORP</parentCustomerName>
      <division>HC</division>
      <identifiers>
        <idType>EIN</idType>

```



```

        <idValue>98-7654325</idValue>
        <isPrimary>Y</isPrimary>
    </identifiers>
    <address>
        <addressEffDate>2019-01-01</addressEffDate>
        <addressType>MAIN</addressType>
        <mailingName>UK OIL AND GAS CORP</mailingName>
        <address1>West Park</address1>
        <address2>West Street</address2>
        <address3>River Side</address3>
        <attentionName></attentionName>
        <city>Belford</city>
        <state>Northumberland</state>
        <zip>NE707DT</zip>
        <country>UK</country>
    </address>
    <email>ukoandg@example.com</email>
    <phones>
        <phoneType>BUSN</phoneType>
        <phoneValue>01668-255-255</phoneValue>
    </phones>
    <relatedPersons>
        <idType></idType>
        <idValue></idValue>
        <personRelationshipType></personRelationshipType>
        <startDate></startDate>
        <endDate></endDate>
        <financialRelationshipSw></financialRelationshipSw>
    </relatedPersons>
    <characteristics>
        <characteristicsList>
            <characteristicType>PER_CAT</characteristicType>
            <characteristicValue>EMPOLYER</characteristicValue>
            <effectiveDate>2019-01-01</effectiveDate>
        </characteristicsList>
    </characteristics>
    <billGroupData>
        <seqNo>1</seqNo>
        <billGroupName>UK OIL AND GAS ACRE</billGroupName>
        <division>HC</division>
        <startDate>2019-01-01</startDate>
        <endDate>2019-12-31</endDate>
        <financialRelationshipSw>false</financialRelationshipSw>
        <identifiers>
            <idType>EIN</idType>
            <idValue>98-7654326</idValue>
            <isPrimary>Y</isPrimary>
        </identifiers>
        <address>
            <addressEffDate>2019-01-01</addressEffDate>
            <addressType>MAIN</addressType>
            <mailingName>UK OIL AND GAS ACTIVE</mailingName>
            <address1>High Park</address1>
            <address2>High Street</address2>
            <address3>Lake Side</address3>
            <attentionName></attentionName>
            <city>Winchester</city>
            <state>Hampshire</state>
            <zip>SO206HR</zip>
            <country>UK</country>
        </address>
        <email>ukoandga@example.com</email>
        <phones>
            <phoneType>BUSN</phoneType>

```

```

    <phoneValue>01962-556-0122</phoneValue>
  </phones>
  <characteristics>
    <characteristicsList>
      <characteristicType>PER_CAT</characteristicType>
      <characteristicValue>OTHER</characteristicValue>
      <effectiveDate>2019-01-01</effectiveDate>
    </characteristicsList>
  </characteristics>
  <accountData>
    <accountType>Standard</accountType>
    <customerClass>HC</customerClass>
    <billCycle>BK01</billCycle>
    <division>HC</division>
    <billRouteType>POSTAL</billRouteType>
    <identifiers>
      <idType>ACCT_NM</idType>
      <idValue>Standard Account</idValue>
      <isPrimary>true</isPrimary>
    </identifiers>
    <billAddressSource>PER</billAddressSource>
    <address>
      <addressEffDate>2019-01-01</addressEffDate>
      <addressType></addressType>
      <address1></address1>
      <address2></address2>
      <address3></address3>
      <attentionName></attentionName>
      <city></city>
      <state></state>
      <zip></zip>
      <country></country>
    </address>
    <autoPayDetails>
      <priority></priority>
      <startDate></startDate>
      <endDate></endDate>
      <percentage></percentage>
      <autoPayMethod></autoPayMethod>
      <autoPayRouteType></autoPayRouteType>
      <autoPaySourceCode></autoPaySourceCode>
      <accountNumber></accountNumber>
      <expiryMonth></expiryMonth>
      <expiryYear></expiryYear>
      <name></name>
      <maxWithdrawalAmount></maxWithdrawalAmount>
      <comments></comments>
    </autoPayDetails>
    <characteristics>
      <characteristicsList>
        <characteristicType></characteristicType>
        <characteristicValue></characteristicValue>
        <effectiveDate></effectiveDate>
      </characteristicsList>
    </characteristics>
  </accountData>
  <accountData>
    <accountType>Retention</accountType>
    <customerClass>HC</customerClass>
    <billCycle>BK02</billCycle>
    <division>HC</division>
    <billRouteType>POSTAL</billRouteType>
    <identifiers>
      <idType>ACCT_NM</idType>

```

```

        <idValue>Retention Account</idValue>
        <isPrimary>true</isPrimary>
    </identifiers>
    <billAddressSource>ACOV</billAddressSource>
    <address>
        <addressEffDate>2019-01-01</addressEffDate>
        <addressType>OVRD</addressType>
        <address1>Central Park</address1>
        <address2>Central Park Street</address2>
        <address3>Near Street Bank</address3>
        <attentionName></attentionName>
        <city>Stamford</city>
        <state>Lincolnshire</state>
        <zip>06903</zip>
        <country>UK</country>
    </address>
    <autoPayDetails>
        <priority></priority>
        <startDate></startDate>
        <endDate></endDate>
        <percentage></percentage>
        <autoPayMethod></autoPayMethod>
        <autoPayRouteType></autoPayRouteType>
        <autoPaySourceCode></autoPaySourceCode>
        <accountNumber></accountNumber>
        <expiryMonth></expiryMonth>
        <expiryYear></expiryYear>
        <name></name>
        <maxWithdrawalAmount></maxWithdrawalAmount>
        <comments></comments>
    </autoPayDetails>
    <characteristics>
        <characteristicsList>
            <characteristicType></characteristicType>
            <characteristicValue></characteristicValue>
            <effectiveDate></effectiveDate>
        </characteristicsList>
    </characteristics>
</accountData>
<policyData>
    <policyNumber>AP235100</policyNumber>
    <sourceSystem>SMALLPRIME</sourceSystem>
    <startDate>2019-01-01</startDate>
    <endDate>2019-12-31</endDate>
    <policyDescription>Active Employee Health Care Policy</
policyDescription>
    <runOutEndDate>2020-03-31</runOutEndDate>
    <runOutAdminOption>NROA</runOutAdminOption>
    <policyPersons>
        <idType></idType>
        <idValue></idValue>
        <startDate></startDate>
        <endDate></endDate>
        <policyPerRole></policyPerRole>
    </policyPersons>
    <characteristics>
        <characteristicsList>
            <characteristicType></characteristicType>
            <characteristicValue></characteristicValue>
            <effectiveDate></effectiveDate>
        </characteristicsList>
    </characteristics>
</policyData>
<policyData>

```

```

    <policyNumber>AP235101</policyNumber>
    <sourceSystem>SMALLPRIME</sourceSystem>
    <startDate>2019-01-01</startDate>
    <endDate>2019-12-31</endDate>
    <policyDescription>Retiree Employee Health Care Policy</
policyDescription>
    <runOutEndDate>2020-03-31</runOutEndDate>
    <runOutAdminOption>PERC</runOutAdminOption>
    <policyPersons>
      <idType></idType>
      <idValue></idValue>
      <startDate></startDate>
      <endDate></endDate>
      <policyPerRole></policyPerRole>
    </policyPersons>
    <characteristics>
      <characteristicsList>
        <characteristicType></characteristicType>
        <characteristicValue></characteristicValue>
        <effectiveDate></effectiveDate>
      </characteristicsList>
    </characteristics>
  </policyData>
</billGroupData>
<billGroupData>
  <seqNo>2</seqNo>
  <billGroupName>UK OIL AND GAS COBRA</billGroupName>
  <division>HC</division>
  <startDate>2019-01-01</startDate>
  <endDate>2019-12-31</endDate>
  <financialRelationshipSw>>false</financialRelationshipSw>
  <identifiers>
    <idType>EIN</idType>
    <idValue>98-765-4320</idValue>
    <isPrimary>Y</isPrimary>
  </identifiers>
  <address>
    <addressEffDate>2019-01-01</addressEffDate>
    <addressType>MAIN</addressType>
    <mailingName>UK OIL AND GAS COBRA</mailingName>
    <address1>City Park</address1>
    <address2>City Street</address2>
    <address3>River Side</address3>
    <attentionName></attentionName>
    <city>Oakham</city>
    <state>Rutland</state>
    <zip>01005</zip>
    <country>UK</country>
  </address>
  <email>ukoandgc@example.com</email>
  <phones>
    <phoneType>BUSN</phoneType>
    <phoneValue>01572-556-012</phoneValue>
  </phones>
  <characteristics>
    <characteristicsList>
      <characteristicType>PER_CAT</characteristicType>
      <characteristicValue>OTHER</characteristicValue>
      <effectiveDate>2019-01-01</effectiveDate>
    </characteristicsList>
  </characteristics>
  <accountData>
    <accountType>Standard</accountType>
    <customerClass>HC</customerClass>
  </accountData>

```

```

<billCycle>BK01</billCycle>
<division>HC</division>
<billRouteType>POSTAL</billRouteType>
<identifiers>
  <idType>ACCT_NM</idType>
  <idValue>Standard Account</idValue>
  <isPrimary>true</isPrimary>
</identifiers>
<billAddressSource>PER</billAddressSource>
<address>
  <addressEffDate>2019-01-01</addressEffDate>
  <addressType></addressType>
  <address1></address1>
  <address2></address2>
  <address3></address3>
  <attentionName></attentionName>
  <city></city>
  <state></state>
  <zip></zip>
  <country></country>
</address>
<autoPayDetails>
  <priority></priority>
  <startDate></startDate>
  <endDate></endDate>
  <percentage></percentage>
  <autoPayMethod></autoPayMethod>
  <autoPayRouteType></autoPayRouteType>
  <autoPaySourceCode></autoPaySourceCode>
  <accountNumber></accountNumber>
  <expiryMonth></expiryMonth>
  <expiryYear></expiryYear>
  <name></name>
  <maxWithdrawalAmount></maxWithdrawalAmount>
  <comments></comments>
</autoPayDetails>
<characteristics>
  <characteristicsList>
    <characteristicType></characteristicType>
    <characteristicValue></characteristicValue>
    <effectiveDate></effectiveDate>
  </characteristicsList>
</characteristics>
</accountData>
<accountData>
  <accountType>Retention</accountType>
  <customerClass>HC</customerClass>
  <billCycle>BK02</billCycle>
  <division>HC</division>
  <billRouteType>POSTAL</billRouteType>
  <identifiers>
    <idType>ACCT_NM</idType>
    <idValue>Retention Account</idValue>
    <isPrimary>true</isPrimary>
  </identifiers>
  <billAddressSource>ACOV</billAddressSource>
  <address>
    <addressEffDate>2019-01-01</addressEffDate>
    <addressType>OVRD</addressType>
    <address1>Corporate Park</address1>
    <address2>Central Avenue</address2>
    <address3>Near Federal Bank</address3>
    <attentionName></attentionName>
    <city>Dartmouth</city>

```

```

        <state>Devon</state>
        <zip>02714</zip>
        <country>UK</country>
    </address>
    <autoPayDetails>
        <priority></priority>
        <startDate></startDate>
        <endDate></endDate>
        <percentage></percentage>
        <autoPayMethod></autoPayMethod>
        <autoPayRouteType></autoPayRouteType>
        <autoPaySourceCode></autoPaySourceCode>
        <accountNumber></accountNumber>
        <expiryMonth></expiryMonth>
        <expiryYear></expiryYear>
        <name></name>
        <maxWithdrawalAmount></maxWithdrawalAmount>
        <comments></comments>
    </autoPayDetails>
    <characteristics>
        <characteristicsList>
            <characteristicType></characteristicType>
            <characteristicValue></characteristicValue>
            <effectiveDate></effectiveDate>
        </characteristicsList>
    </characteristics>
</accountData>
<policyData>
    <policyNumber>AP235102</policyNumber>
    <sourceSystem>SMALLPRIME</sourceSystem>
    <startDate>2019-01-01</startDate>
    <endDate>2019-12-31</endDate>
    <policyDescription>Active COBRA Employee Health Care
Policy</policyDescription>
    <runOutEndDate>2020-03-31</runOutEndDate>
    <runOutAdminOption>NROA</runOutAdminOption>
    <policyPersons>
        <idType></idType>
        <idValue></idValue>
        <startDate></startDate>
        <endDate></endDate>
        <policyPerRole></policyPerRole>
    </policyPersons>
    <characteristics>
        <characteristicsList>
            <characteristicType></characteristicType>
            <characteristicValue></characteristicValue>
            <effectiveDate></effectiveDate>
        </characteristicsList>
    </characteristics>
</policyData>
<policyData>
    <policyNumber>AP235103</policyNumber>
    <sourceSystem>SMALLPRIME</sourceSystem>
    <startDate>2019-01-01</startDate>
    <endDate>2019-12-31</endDate>
    <policyDescription>Retiree COBRA Employee Health Care
Policy</policyDescription>
    <runOutEndDate>2020-03-31</runOutEndDate>
    <runOutAdminOption>PERC</runOutAdminOption>
    <policyPersons>
        <idType></idType>
        <idValue></idValue>
        <startDate></startDate>

```

```

        <endDate></endDate>
        <policyPerRole></policyPerRole>
    </policyPersons>
    <characteristics>
        <characteristicsList>
            <characteristicType></characteristicType>
            <characteristicValue></characteristicValue>
            <effectiveDate></effectiveDate>
        </characteristicsList>
    </characteristics>
</policyData>
</billGroupData>
</parentCustomerData>
</customerStructureMessage>
</schema>

```

## Health Care Inbound Message

---

On calling the **C1-HCInboundMessage** web service, you can create a health care inbound message using a health care inbound message type. You can create a health care inbound message type using the **Health Care Inbound Message Type (C1-HCInboundMsgType)** business object. The health care inbound message type helps the system to determine:

- **Inbound Message Business Object** - The business object using which the health care inbound message should be created in the system. You must specify the **Health Care Inbound Message (C1-HCInboundMessage)** business object in the health care inbound message type.
- **Customer Registration Type** - The health care inbound message creates the person, account, policy, and policy plan through a customer registration object. The system creates the customer registration object using the customer registration type specified in the health care inbound message type. The customer registration type helps the system to determine:
  - **Customer Registration Business Object** - The business object using which the customer registration object should be created in the system. You must specify the **Customer Registration - Health Care (C1-CustomerRegistrationHC)** business object in the customer registration type.
  - **Person Business Object** - The business object using which the person should be created in the system. You must specify the **Person BO (C1\_PERSON\_BO)** business object in the customer registration type.
  - **Account Business Object** - The business object using which the account should be created in the system. You must specify the **Account BO (C1-AccountBO)** business object in the customer registration type.
  - **Policy Plan Business Object** - The business object using which the policy plan should be created in the system. You must specify the **Policy Plan (C1-PolicyPlan)** business object in the customer registration type.
  - **Membership Business Object** - The business object using which the membership should be created in the system. You must specify the **Membership (C1-Membership)** business object in the customer registration type.
  - **Address Business Object** - The business object using which the effective dated address should be created in the system. You must specify the **Address (C1-Address)** business object in the customer registration type.

While creating a health care inbound message type for the fully-insured health care business, you must use a customer registration type where the **Approval Required**, **Final Approval Required**, and **Manual Billing Hierarchy and Pricing** options are not selected. However, while creating a health care inbound message type for the self-funded health care business, you must use a customer registration type where the **Final Approval Required** and **Manual Billing Hierarchy and Pricing** options are selected, but the **Approval Required** option is not selected.

The **C1-HCInboundMessage** web service enables you to do the following depending on the person type and the category to which the policy type belongs:

Person Type	Policy Category	Enables you to:
Parent Customer	Self-Funded	<ul style="list-style-type: none"> <li>• Create or edit a parent customer</li> <li>• Create or edit a bill group of the parent customer</li> <li>• Create the derivation and pricing parameters for the bill group</li> <li>• Create or edit the accounts of a bill group</li> <li>• Create or edit the policies of a bill group</li> </ul>
	Fully-Insured Group	<ul style="list-style-type: none"> <li>• Create or edit a parent customer</li> <li>• Create or edit a bill group of the parent customer</li> <li>• Create the derivation and pricing parameters for the bill group</li> <li>• Create or edit the accounts of the parent customer and bill group</li> <li>• Create or edit the policies of the parent customer and bill group</li> <li>• Create or edit the plans of the policies</li> <li>• Associate one or more pricing rule types with a policy plan</li> <li>• Create or edit the pricing rules of the policy plans</li> <li>• Terminate, reinstate, or renew policies of the parent customer and bill group</li> </ul>
Bill Group	Self-Funded	<ul style="list-style-type: none"> <li>• Create or edit a bill group</li> <li>• Create the derivation and pricing parameters for the bill group</li> <li>• Create or edit the accounts of the bill group</li> <li>• Create or edit the policies of the bill group</li> </ul>



Person Type	Policy Category	Enables you to:
	Fully-Insured Group	<ul style="list-style-type: none"> <li>• Create or edit a bill group</li> <li>• Create the derivation and pricing parameters for the bill group</li> <li>• Create or edit the accounts of the bill group</li> <li>• Create or edit the policies of the bill group</li> <li>• Create or edit the plans of the policies</li> <li>• Associate one or more pricing rule types with a policy plan</li> <li>• Create or edit the pricing rules of the policy plans</li> <li>• Terminate, reinstate, or renew policies of the bill group</li> </ul>
Any Other Person Type	-	<ul style="list-style-type: none"> <li>• Create or edit a person</li> <li>• Credit or edit the accounts of the person</li> <li>• Create or edit the memberships of the policy plans</li> <li>• Add or remove members from a membership</li> <li>• Create or edit the one-time or recurring pass-through billable charges for a membership</li> </ul>

The following table describes how the system behaves when the respective entity information is given in a health care inbound message:

Entity	System Behavior
Person	<p>The system uses the <b>C1-PERSTYPE</b> feature configuration to decide whether the person type specified in the health care inbound message represents <b>Parent Customer</b> or <b>Bill Group</b>. If the person type specified in the health care inbound message matches the person type specified in the <b>Bill Group Person Type</b> or <b>Parent Person Type</b> option type of the <b>C1-PERSTYPE</b> feature configuration, the system creates or updates the person, account, policy, policy plan, and address through a customer registration object. Note that the memberships, pass-through billable charges, and pricing rules are created directly and not via customer registration object. However, if the person type specified in the health care inbound message does not match the person type specified in the <b>Bill Group Person Type</b> or <b>Parent Person Type</b> option type, the system creates or updates the person and its other entities directly and not through a customer registration object. In this case, the system only refers the customer registration type for the business objects using which the person, account, policy plan, membership, and address should be created or updated in the system.</p> <p>If the related person information is given for a bill group and the person type of the related person is <b>Parent Customer</b>, then the bill group is related to the parent customer using the person relationship type which is specified in the <b>Person Relationship Type</b> option type of the <b>C1-ASOBLLNG</b> feature configuration.</p> <p>If the derivation and pricing parameters are specified for a bill group, the system automatically creates one sort record for the bill group. Here, the sort ID is set to the bill group ID. The start and end dates of the sort record are set to the bill group and parent customer's relationship start and end dates. Once the sort record is created, the system creates the derivation and pricing parameters for the bill group and sort ID combination.</p> <div data-bbox="581 1058 1461 1230" style="border: 1px solid black; padding: 5px;"> <p><b>Note:</b> The system supports the <b>Add</b> and <b>Update</b> operations for all entities except the derivation and pricing parameters for the bill group. Through the health care inbound message, each time, the system creates a new derivation and pricing parameters record for the bill group and does not update the existing derivation and pricing parameters record of the bill group.</p> </div>
Account	<p>While creating an account, the system defines the <b>Invoice Type</b> characteristic for the account. It stores the account type given in the account information in the characteristic type which is specified in the <b>Invoice Type Characteristic Type</b> option type of the <b>C1-ASOBLLNG</b> feature configuration.</p>

Entity	System Behavior
Policy	<p>If the fully-insured policy information is given for a bill group, the system does the following:</p> <ul style="list-style-type: none"> <li>• Associates the bill group with the policy using the policy person role which is specified in the <b>Bill Group Policy Person Role</b> option type of the <b>C1-ASOBLNG</b> feature configuration</li> <li>• Associates the parent customer with the policy using the policy person role which is specified in the <b>Parent Customer Policy Person Role</b> option type of the <b>C1-ASOBLNG</b> feature configuration</li> </ul> <p>However, if the fully-insured policy information is given for a parent customer, the system does the following:</p> <ul style="list-style-type: none"> <li>• Associates the parent customer with the policy using the policy person role which is specified in the <b>Parent Customer Policy Person Role</b> option type of the <b>C1-ASOBLNG</b> feature configuration</li> </ul> <p>If the self-funded policy information is given for a bill group, the system does the following:</p> <ul style="list-style-type: none"> <li>• Associates the bill group with the policy using the policy person role which is specified in the <b>Bill Group Policy Person Role</b> option type of the <b>C1-ASOBLNG</b> feature configuration</li> <li>• Associates the parent customer with the policy using the policy person role which is specified in the <b>Parent Customer Policy Person Role</b> option type of the <b>C1-ASOBLNG</b> feature configuration</li> </ul> <p>On renewing a fully-insured group policy, the system removes the end date from the policy and stamps the renewal date against the policy.</p> <div style="border: 1px solid black; padding: 5px;"> <p><b>Note:</b> You can renew a policy where the policy category is set to <b>Self-Funded</b> from the user interface and not through a health care inbound message. However, you can renew a policy where the policy category is set to <b>Fully-Insured Group</b> through a health care inbound message and not from the user interface.</p> </div> <p>On terminating a fully-insured group policy, the system updates the end date of the following entities with the termination date:</p> <ul style="list-style-type: none"> <li>• Policy</li> <li>• Policy Person</li> <li>• Policy Plan</li> <li>• Membership</li> <li>• Membership Person</li> <li>• Pricing Rule</li> </ul> <p>However, before updating the end dates, the system stores the original end date in the <b>ORG_END_DT</b> column of the respective table for all the above entities. The status of the policy is changed to the status which is specified in the <b>Policy Termination Status</b> option type of the <b>C1-ASOBLNG</b> feature configuration.</p> <p>On reinstating a fully-insured group policy, the system updates the end date of the above entities with the original end date. In addition, the status of the policy is changed to the status which is specified in the <b>Policy Reinstatement Status</b> option type of the <b>C1-ASOBLNG</b> feature configuration.</p>

Entity	System Behavior
Policy Plan	While creating a policy plan, the system requires either the price item or at least one pricing rule type. The system allows you to associate only those pricing rule types where the category is set to <b>Age Based</b> , <b>Tier Based</b> , or <b>Pass-Through Billable Charge</b> .
Pricing Rule Type	The system does not allow you to create or update a pricing rule type through a health care inbound message.
Pricing Rule	<p>The system allows you to define and edit the age-based and tier-based pricing rules of the policy plan. Note that the system supports the <b>Replace</b> operation and not the <b>Update</b> operation when you are editing these pricing rules through a health care inbound message.</p> <p><b>Note:</b></p> <p>You can define and edit the age-based and tier-based pricing rules through a health care inbound message and not from the user interface.</p> <p>You can create the following pricing rules from the user interface and not through a health care inbound message:</p> <ul style="list-style-type: none"> <li>• Claim</li> <li>• Specific Stop-Loss</li> <li>• Aggregate Stop-Loss</li> <li>• Retention Type Claim Based</li> <li>• Retention Type Enrollment Based</li> <li>• One-Time Flat Fees</li> <li>• Recurring Flat Fees</li> <li>• Ancillary</li> <li>• Discount Arrangement</li> <li>• Level Funded</li> </ul>
Pass-Through Billable Charge	If the price item, account identifier type, and account identifier are given in the billable charge information, the system directly creates an SQI based billable charge when you process the health care inbound message. But, if only the price item is given in the billable charge information, the system checks whether the price item is included in any pricing rule type where the pricing rule type category is set to <b>Pass-Through Billable Charge</b> . If so, the system checks whether the pass-through billable charge pricing rule type is associated with the policy plan to which the membership belongs (for which the billable charge information is received). If so, the system creates an SQI based billable charge using the respective pass-through billable charge pricing rule type.

**Note:**

We recommend you to create or update the following through separate health care inbound messages:

- Entities, such as parent customer, bill group, accounts, policies, and policy plans
- Pricing rules
- Membership, member persons, and pass-through billable charges

On calling the **C1-HCInboundMessage** web service, a health care inbound message is created in the **Pending** status. When the **Health Care Inbound Message Periodic Monitor (C1-HCINB)** batch is executed, the system checks whether there are any health care inbound messages in the **Pending** status. If there is a health care inbound message in the **Pending** status, the system validates the inbound message. If the health care inbound message is successfully validated, it is processed further and the entities are either created or updated in the system based on the available information.

Alternatively, the system enables you to submit the health care inbound messages for validation and processing from the user interface. On submitting a health care inbound message, the system validates the health care inbound message. If a health care inbound message is successfully validated, it is processed further and the required entities are created or updated in the system based on the available information.

If the person type is **Parent Customer**, the customer registration object is created in the **Complete** status. However, if the person type is **Bill Group**, the customer registration object is created in the **Bill Group Approved** status. The policies are created in the **In Force/Active** status and the pricing rules are created in the **Active** status. Finally, the status of the health care inbound message is changed to **Processed**.

**Note:** The above status transition is mentioned for a customer registration object based on the assumption that the data sent through the health care inbound message will be pre-approved and does not require any approval in the system.

If any error occurs while validating or processing a health care inbound message, the status of the health care inbound message is changed to **Rejected**. The system enables you to either reprocess or void a rejected health care inbound message. The system can reprocess a health care inbound message only when its status is changed to **Pending**. Using the **Retry** option, you can change the status of the health care inbound message from **Rejected** to **Pending**. The **Health Care Inbound Message Periodic Monitor (C1-HCINB)** batch will then reconsider and reprocess the health care inbound message.

You can also configure the system such that the batch can automatically retry to process the rejected health care inbound messages. However, it will attempt to retry only when the **Maximum Retry** parameter in the **Retry for To Dos (C1-TODORETRY)** algorithm is set to a value greater than zero. Also, the maximum number of times the batch can attempt to retry and reprocess a health care inbound message depends on the value defined in the **Maximum Retry** parameter.

At present, if a customer registration object is created through a health care inbound message, you cannot edit the customer registration object from the user interface. You can only edit such customer registration objects through a health care inbound message.

### **Related Topics**

<b>For more information on...</b>	<b>See...</b>
How to setup the <b>C1-ASOBLNG</b> feature configuration	<a href="#">Setting the C1-ASOBLNG Feature Configuration</a> on page 2889
How to setup the <b>C1-PERSTYPE</b> feature configuration	<a href="#">Setting the C1_PERSTYPE Feature Configuration</a> on page 2920

### **Prerequisites**

To use the health care inbound message feature, you need to do the following:

- Define the required customer registration types in the system.

**Note:** The health care inbound message creates the person, account, policy, and policy plan through a customer registration object. The system creates the customer registration object using the customer registration type specified in the health care inbound message type. While creating a health care inbound message type for the fully-insured health care business, you must use a customer registration type where the **Approval Required**, **Final Approval Required**, and **Manual Billing Hierarchy and Pricing** options are not selected. However, while creating a health care inbound message type for the self-funded health care business, you must use a customer registration type where the **Final Approval Required** and **Manual Billing Hierarchy and Pricing** options are selected, but the **Approval Required** option is not selected.

- Define the required health care inbound message types in the system.
- Define the required characteristic types where the characteristic entity is set to **Inbound Message Type**.
- Define the required characteristic types where the characteristic entity is set to **Inbound Message**.
- Define the values for the required parameters in the **C1-HCINVAL**, **C1-HCINPROC**, **C1-TODORETRY**, and **C1-TDCRINMSG** algorithms.
- Define the values for the **C1-SourceSystemLookup** and **C1-ExtLookRetTypeRateOpt** extendable lookups.
- Define the values for the **PER\_OR\_BUS\_FLG**, **NAME\_TYPE\_FLG**, **ADDRESS\_TYPE\_FLG**, **BILL\_ADDR\_SRCE\_FLG**, **BILL\_FORMAT\_FLG**, and **RUNOUT\_ADM\_OPT\_FLG** lookup fields.
- Set the values for the following option types in the **C1-ASOBLNG** feature configuration:
  - Person Relationship Type
  - Bill Group Policy Person Role
  - Parent Customer Policy Person Role
  - Invoice Type Characteristic Type
  - Policy Termination Status
  - Policy Reinstatement Status
  - Default Rate Option – Flat
  - Default Rate Option – Percentage
  - Age Based Parameter
- Set the values for the following option types in the **C1-PERSTYPE** feature configuration:
  - Bill Group Person Type
  - Parent Person Type
- Define the required person identifier types, account identifier types, person relationship types, characteristic types, phone types, customer classes, bill cycles, collection classes, divisions, bill route types, charge types, currencies, bill periods, invoice frequencies, distribution codes, auto pay route types, auto pay sources, account relationship types, policy types, policy person roles and contract relationship types in the application.
- Define the values for the **C1\_INVOICE\_DAY\_BILL\_PERIOD\_FLG** lookup field.

**Note:** Each lookup field value should be mapped to a valid bill period which exists in the system. You must then define this lookup field value as a predefined value for the **C1OFFRST** characteristic type. The system will then use the bill period configured for the respective invoice day when the **C1OFFRST** characteristic is defined for the account.

- Define the required predefined values for the **C1OFFRST** characteristic type.
- Set the batch control type of the **Health Care Inbound Message Periodic Monitor (C1-HCINB)** batch to **Timed** and define the following attributes:
  - Time Interval
  - Timer Active
  - User ID
  - Batch Language
  - Email Address
- Define the required status reasons for the status to which a policy must be transitioned on policy termination.
- Define the required status reasons for the status to which a policy must be transitioned on policy reinstatement.

- Define the bill cancel reasons which you want to use when the premium bill segment is canceled during the policy or membership termination.
- Define the required exchange rates in the system.
- Attach a currency conversion algorithm to the **Currency Conversion For Bill Segments** algorithm spot of the required divisions.

### Related Topics

For more information on...	See...
How to setup the <b>C1-ASOBLNG</b> feature configuration	<a href="#">Setting the C1-ASOBLNG Feature Configuration</a> on page 2889
How to setup the <b>C1-PERSTYPE</b> feature configuration	<a href="#">Setting the C1_PERSTYPE Feature Configuration</a> on page 2920

## Health Care Inbound Message Status Transition through User Interface

The following figure graphically indicates how a health care inbound message moves from one status to another when it is validated and processed through the user interface:

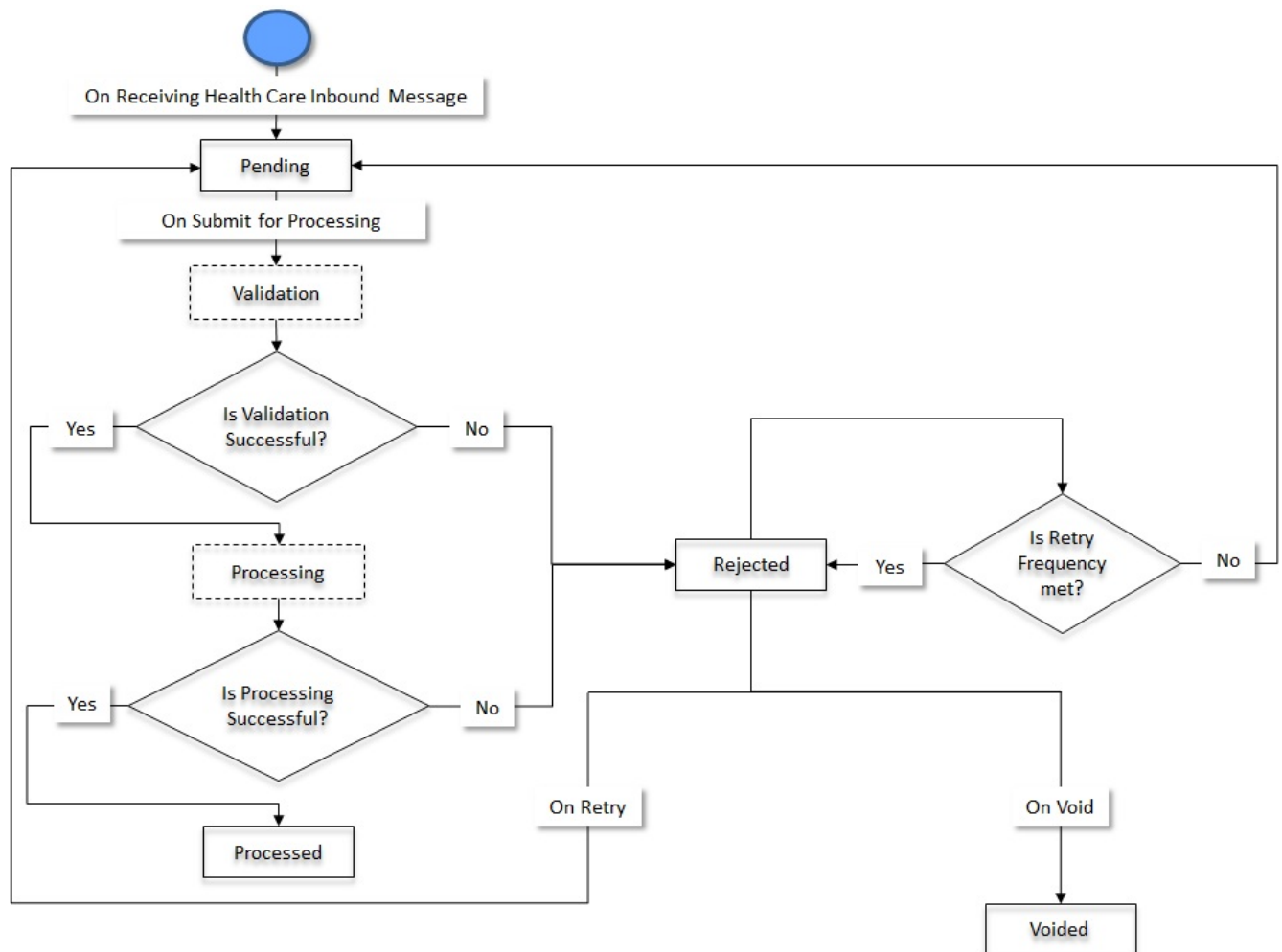

## Health Care Inbound Message Status Transition through a Batch Process

The following figure graphically indicates how a health care inbound message moves from one status to another when it is validated and processed through the **Health Care Inbound Message Periodic Monitor (C1-HCINB)** batch:

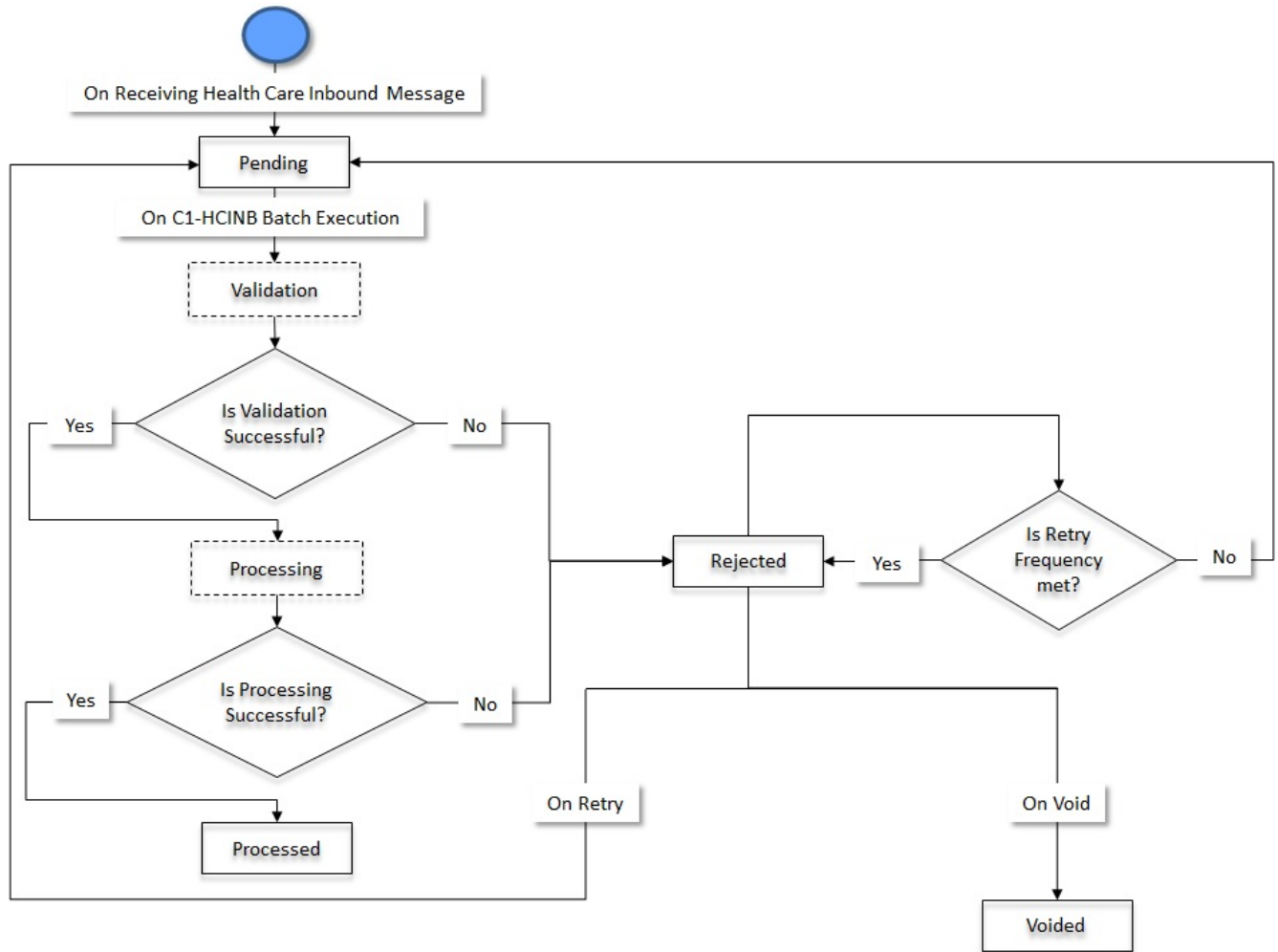

## Algorithms Used in C1-HCInboundMessage

The following table lists the algorithms which are used in the lifecycle of the **C1-HCInboundMessage** business object:

Status	System Event	Algorithm	Algorithm Type	Description
Pending	Monitor	C1-AT-RQJ	C1-GEN-BOMNJ	Refer to <a href="#">C1-AT-RQJ</a> on page 1762.
Validation	Monitor	F1-AT-RQJ	F1-GEN-BOMNJ	Refer to <a href="#">F1-AT-RQJ</a> on page 1257.
	Enter	C1-HCINVAL	C1-HCINVAL	Refer to <a href="#">C1-HCINVAL</a> on page 1873.



Status	System Event	Algorithm	Algorithm Type	Description
Processing	Monitor	F1-AT-RQJ	F1-GEN-BOMNJ	Refer to <a href="#">F1-AT-RQJ</a> on page 1257.
	Enter	C1-HCINPROC	C1-HCINPROC	Refer to <a href="#">C1-HCINPROC</a> on page 1874.
Rejected	Monitor	C1-TODORETRY	C1-TODORETRY	Refer to <a href="#">C1-TODORETRY</a> on page 1772.
	Enter	C1-TDCRINMSG	F1-TDCREATE	Refer to <a href="#">C1-TDCRINMSG</a> on page 1772.
Processed	-	-	-	-
Voided	-	-	-	-

### C1-AT-RQJ

This algorithm is invoked when the status of the customer or membership inbound message is changed to **Pending**. If the **isRetried** flag in the inbound message is set to **true**, it resets the flag to **false**.

It contains the following parameters:

- **Next Status** – Used when you want to override the default next status specified in the lifecycle.
- **Next Transition Condition** – Used when you want to override the default next transition condition specified in the lifecycle.

**Note:** At a time, you can specify value for either the **Next Status** or **Next Transition Condition** parameter. If you don't specify any value for these parameters, the system will transition the business object to the default next status specified in its lifecycle.

### F1-AT-RQJ

This algorithm transitions the current status of the business object to the specified status. It contains the following parameters:

- **Next Status** – Used when you want to override the default next status specified in the lifecycle.
- **Next Transition Condition** – Used when you want to override the default next transition condition specified in the lifecycle.

At a time, you can specify value for either the **Next Status** or **Next Transition Condition** parameter. If you don't specify any value for these parameters, the system will transition the business object to the default next status specified in its lifecycle.

### C1-HCINVAL

Health Care Inbound Message - Validation

This algorithm is invoked when you execute the **Health Care Inbound Message Periodic Monitor (C1-HCINB)** batch or click the **Submit for Processing** button in the **Inbound Message** screen. It validates the health care inbound message which is in the **Pending** status. It checks the following:

- Whether the details of the parent customer are given in the bill group information.
- Whether the primary identifier is specified for the parent customer and bill group.
- Whether multiple primary identifiers are not specified for the parent customer and bill group.

- Whether the expiration year and month are specified in the account's auto pay details when the **Expiration Date Required** option is selected for the tender type which is specified in the auto pay source.
- Whether the expiration year is not earlier than 1755.
- Whether the expiration month lies between 1 and 12.

If the validation fails due to any reason, the status of the health care inbound message is changed to **Rejected**. In addition, the appropriate log entry is added which you can view in the **Inbound Message Log** zone.

It contains the following parameters:

- **Next Status** - Used when you want to override the default next status specified in the lifecycle.
- **Next Transition Condition** - Used when you want to override the default next transition condition specified in the lifecycle.

**Note:** At a time, you can specify value for either the **Next Status** or **Next Transition Condition** parameter. If you don't specify any value for these parameters, the system will transition the business object to the default next status specified in its lifecycle.

### C1-HCINPROC

This algorithm is invoked once a health care inbound message is successfully validated. It processes the health care inbound message and creates or updates the parent customers, bill groups (including derivation and pricing parameters for the bill group), accounts, self-funded or fully-insured group policies, policy plans, memberships, member persons, pass-through billable charges, and pricing rules. In addition, it allows you to terminate, reinstate, and renew a fully-insured group policy.

If the person type specified in the health care inbound message matches the person type specified in the **Bill Group Person Type** or **Parent Person Type** option type of the **C1-PERSTYPE** feature configuration, the system creates or updates the person, account, policy, policy plan, and address through a customer registration object. The memberships, pass-through billable charges, and pricing rules are created directly and not via customer registration object. However, if the person type specified in the health care inbound message does not match the person type specified in the **Bill Group Person Type** or **Parent Person Type** option type of the **C1-PERSTYPE** feature configuration, the system creates or updates the person and its other entities directly and not through a customer registration object. In this case, the system only refers the customer registration type for the business objects using which the person, account, policy plan, membership, and address should be created or updated in the system.

If the processing fails due to any reason, the status of the health care inbound message is changed to **Rejected**. In addition, the appropriate log entry is added which you can view in the **Inbound Message Log** zone.

It contains the following parameters:

- **Next Status** - Used when you want to override the default next status specified in the lifecycle.
- **Next Transition Condition** - Used when you want to override the default next transition condition specified in the lifecycle.

**Note:** At a time, you can specify value for either the **Next Status** or **Next Transition Condition** parameter. If you don't specify any value for these parameters, the system will transition the business object to the default next status specified in its lifecycle.

### C1-TODORETRY

This algorithm is invoked when the status of the customer or membership inbound message is changed to **Rejected**. It checks whether the maximum retry attempts are met. If the retry attempt is less than or equal to the value defined in the **Maximum Retry** parameter, the status of the inbound message is changed to **Pending**. However, if the retry attempt is greater than the value defined in the **Maximum Retry** parameter, the status of the inbound message remains as **Rejected**.

**Note:** This algorithm is invoked only when the customer or membership inbound message is validated and processed through the batch process.

It contains the following parameters:

- **Maximum Retry** – Used to specify the maximum number of times the inbound message can be revalidated and reprocessed on failure.
- **Maximum Retry Element Name** – This parameter is not used at the moment.

If you do not specify any value for the **Maximum Retry** parameter, the system uses the value defined in the **To Do Maximum Retries** status option (which is defined in the lifecycle of the **C1-CustomerInboundMessage** and **C1-MemberInboundMessage** business object) to check whether the maximum retry attempts are met. If the value is not specified for the **To Do Maximum Retries** status option, the system does not allow revalidating and reprocessing an inbound message, and the status of the inbound message remains as **Rejected**.

## C1-TDCRINMSG

This algorithm is invoked when the status of the customer or membership inbound message is changed to **Rejected**. It creates a To Do using the specified To Do type and assigns it to users with the specified To Do role.

It contains the following parameters:

- **To Do Type** - Used to specify the type of notification that you want to generate when the inbound message validation or processing fails.
- **To Do Role** - Used to specify the To Do role to indicate the users to whom you want to send the notification when the inbound message validation or processing fails.

The rest of the parameters, such as **To Do Type Element Name**, **To Do Role Element Name**, **Message Category**, **Message Number**, **Characteristic Type For Log Entry**, **To Do Sort Keys Retriever Script**, **Discard Cancel Terminate Reason Element**, **Discard Cancel Terminate Reason**, **Retry Frequency**, and **Retry Frequency Element Name**, are not used at the moment.

## Health Care Inbound Message XML Format

**Note:** We recommend you to refer the Health Care Inbound Message schema in parallel while understanding the below mentioned tags. This will help you to understand how the tags are nested in the schema.

Before calling the **C1-HCInboundMessage** inbound web service, you need to ensure that the health care inbound message contains the following tags:

Tag Name	Tag Description	Mandatory (Yes or No)
schema	Used to specify the tags of a health care inbound message.	Yes
bo	Used to indicate the business object using which the health care inbound message should be created in the system. The valid value is: <ul style="list-style-type: none"> <li>• C1-HCInboundMessage</li> </ul>	Yes

Tag Name	Tag Description	Mandatory (Yes or No)						
messageType	<p>You can use this tag within the following tags:</p> <table border="1" data-bbox="602 302 1227 785"> <thead> <tr> <th data-bbox="602 302 797 386">If this tag is used within...</th> <th data-bbox="797 302 1227 386">Then the purpose of the messageType tag is...</th> </tr> </thead> <tbody> <tr> <td data-bbox="602 386 797 638">schema</td> <td data-bbox="797 386 1227 638">           Indicates the health care inbound message type using which the health care inbound message is created in the system.   <b>Note:</b> The system refers the value from within the <b>headerData</b> tag.         </td> </tr> <tr> <td data-bbox="602 638 797 785">headerData</td> <td data-bbox="797 638 1227 785">           Used to specify the health care inbound message type using which the health care inbound message should be created in the system.         </td> </tr> </tbody> </table> <p><b>Note:</b> You must specify a valid health care inbound message type which is in the <b>Active</b> status.</p>	If this tag is used within...	Then the purpose of the messageType tag is...	schema	Indicates the health care inbound message type using which the health care inbound message is created in the system.  <b>Note:</b> The system refers the value from within the <b>headerData</b> tag.	headerData	Used to specify the health care inbound message type using which the health care inbound message should be created in the system.	Yes
If this tag is used within...	Then the purpose of the messageType tag is...							
schema	Indicates the health care inbound message type using which the health care inbound message is created in the system.  <b>Note:</b> The system refers the value from within the <b>headerData</b> tag.							
headerData	Used to specify the health care inbound message type using which the health care inbound message should be created in the system.							

Tag Name	Tag Description	Mandatory (Yes or No)												
sourceSystem	<p>You can use this tag within the following tags:</p> <table border="1" data-bbox="602 302 1227 1129"> <thead> <tr> <th data-bbox="602 302 834 380">If this tag is used within...</th> <th data-bbox="834 302 1227 380">Then the purpose of the sourceSystem tag is...</th> </tr> </thead> <tbody> <tr> <td data-bbox="602 380 834 611">schema</td> <td data-bbox="834 380 1227 611">           Indicates the external system from where the health care inbound message is received.   <div data-bbox="846 506 1216 590" style="border: 1px solid black; padding: 2px;"> <b>Note:</b> The system refers the value from within the <b>headerData</b> tag.           </div> </td> </tr> <tr> <td data-bbox="602 611 834 722">headerData</td> <td data-bbox="834 611 1227 722">Used to indicate the external system from where the health care inbound message is received.</td> </tr> <tr> <td data-bbox="602 722 834 869">billLevelParameters</td> <td data-bbox="834 722 1227 869">Used to indicate the source system using which you want to define the derivation and pricing parameters for the bill group.</td> </tr> <tr> <td data-bbox="602 869 834 1016">memberData</td> <td data-bbox="834 869 1227 1016">Used to indicate the source system using which you want to derive the policy where the policy plan is defined.</td> </tr> <tr> <td data-bbox="602 1016 834 1129">policyData</td> <td data-bbox="834 1016 1227 1129">Used to indicate the source system from where the policy is originated.</td> </tr> </tbody> </table> <div data-bbox="602 1150 1227 1262" style="border: 1px solid black; padding: 2px; margin-top: 10px;"> <b>Note:</b> You must specify a source system which is already defined in the <b>C1-SourceSystemLookup</b> extendable lookup. It must be in the <b>Active</b> status.         </div>	If this tag is used within...	Then the purpose of the sourceSystem tag is...	schema	Indicates the external system from where the health care inbound message is received.  <div data-bbox="846 506 1216 590" style="border: 1px solid black; padding: 2px;"> <b>Note:</b> The system refers the value from within the <b>headerData</b> tag.           </div>	headerData	Used to indicate the external system from where the health care inbound message is received.	billLevelParameters	Used to indicate the source system using which you want to define the derivation and pricing parameters for the bill group.	memberData	Used to indicate the source system using which you want to derive the policy where the policy plan is defined.	policyData	Used to indicate the source system from where the policy is originated.	Yes
If this tag is used within...	Then the purpose of the sourceSystem tag is...													
schema	Indicates the external system from where the health care inbound message is received.  <div data-bbox="846 506 1216 590" style="border: 1px solid black; padding: 2px;"> <b>Note:</b> The system refers the value from within the <b>headerData</b> tag.           </div>													
headerData	Used to indicate the external system from where the health care inbound message is received.													
billLevelParameters	Used to indicate the source system using which you want to define the derivation and pricing parameters for the bill group.													
memberData	Used to indicate the source system using which you want to derive the policy where the policy plan is defined.													
policyData	Used to indicate the source system from where the policy is originated.													
externalTransactionId	<p>You can use this tag within the following tags:</p> <table border="1" data-bbox="602 1352 1227 1772"> <thead> <tr> <th data-bbox="602 1352 797 1430">If this tag is used within...</th> <th data-bbox="797 1352 1227 1430">Then the purpose of the externalTransactionId tag is...</th> </tr> </thead> <tbody> <tr> <td data-bbox="602 1430 797 1661">schema</td> <td data-bbox="797 1430 1227 1661">           Indicates the transaction in the external source system which resulted in the health care inbound message.   <div data-bbox="808 1556 1216 1640" style="border: 1px solid black; padding: 2px;"> <b>Note:</b> The system refers the value from within the <b>headerData</b> tag.           </div> </td> </tr> <tr> <td data-bbox="602 1661 797 1772">headerData</td> <td data-bbox="797 1661 1227 1772">Used to indicate the transaction in the external source system which resulted in the health care inbound message.</td> </tr> </tbody> </table>	If this tag is used within...	Then the purpose of the externalTransactionId tag is...	schema	Indicates the transaction in the external source system which resulted in the health care inbound message.  <div data-bbox="808 1556 1216 1640" style="border: 1px solid black; padding: 2px;"> <b>Note:</b> The system refers the value from within the <b>headerData</b> tag.           </div>	headerData	Used to indicate the transaction in the external source system which resulted in the health care inbound message.	No						
If this tag is used within...	Then the purpose of the externalTransactionId tag is...													
schema	Indicates the transaction in the external source system which resulted in the health care inbound message.  <div data-bbox="808 1556 1216 1640" style="border: 1px solid black; padding: 2px;"> <b>Note:</b> The system refers the value from within the <b>headerData</b> tag.           </div>													
headerData	Used to indicate the transaction in the external source system which resulted in the health care inbound message.													

Tag Name	Tag Description	Mandatory (Yes or No)						
externalBatchId	<p>You can use this tag within the following tags:</p> <table border="1" data-bbox="602 302 1227 785"> <thead> <tr> <th data-bbox="602 302 797 386">If this tag is used within...</th> <th data-bbox="797 302 1227 386">Then the purpose of the externalBatchId tag is...</th> </tr> </thead> <tbody> <tr> <td data-bbox="602 386 797 638">schema</td> <td data-bbox="797 386 1227 638"> <p>Indicates the external batch job or batch run number through which the health care inbound message is created.</p> <div data-bbox="808 537 1216 621" style="border: 1px solid black; padding: 2px;"> <p><b>Note:</b> The system refers the value from within the <b>headerData</b> tag.</p> </div> </td> </tr> <tr> <td data-bbox="602 638 797 785">headerData</td> <td data-bbox="797 638 1227 785"> <p>Used to indicate the external batch job or batch run number through which the health care inbound message is created.</p> </td> </tr> </tbody> </table>	If this tag is used within...	Then the purpose of the externalBatchId tag is...	schema	<p>Indicates the external batch job or batch run number through which the health care inbound message is created.</p> <div data-bbox="808 537 1216 621" style="border: 1px solid black; padding: 2px;"> <p><b>Note:</b> The system refers the value from within the <b>headerData</b> tag.</p> </div>	headerData	<p>Used to indicate the external batch job or batch run number through which the health care inbound message is created.</p>	Yes
If this tag is used within...	Then the purpose of the externalBatchId tag is...							
schema	<p>Indicates the external batch job or batch run number through which the health care inbound message is created.</p> <div data-bbox="808 537 1216 621" style="border: 1px solid black; padding: 2px;"> <p><b>Note:</b> The system refers the value from within the <b>headerData</b> tag.</p> </div>							
headerData	<p>Used to indicate the external batch job or batch run number through which the health care inbound message is created.</p>							
externalSourceId	<p>You can use this tag within the following tags:</p> <table border="1" data-bbox="602 875 1227 1232"> <thead> <tr> <th data-bbox="602 875 797 959">If this tag is used within...</th> <th data-bbox="797 875 1227 959">Then the purpose of the externalSourceId tag is...</th> </tr> </thead> <tbody> <tr> <td data-bbox="602 959 797 1148">schema</td> <td data-bbox="797 959 1227 1148"> <p>Displays the external source system ID.</p> <div data-bbox="808 1050 1216 1134" style="border: 1px solid black; padding: 2px;"> <p><b>Note:</b> The system refers the value from within the <b>headerData</b> tag.</p> </div> </td> </tr> <tr> <td data-bbox="602 1148 797 1232">headerData</td> <td data-bbox="797 1148 1227 1232"> <p>Used to specify the external source system ID.</p> </td> </tr> </tbody> </table>	If this tag is used within...	Then the purpose of the externalSourceId tag is...	schema	<p>Displays the external source system ID.</p> <div data-bbox="808 1050 1216 1134" style="border: 1px solid black; padding: 2px;"> <p><b>Note:</b> The system refers the value from within the <b>headerData</b> tag.</p> </div>	headerData	<p>Used to specify the external source system ID.</p>	Yes
If this tag is used within...	Then the purpose of the externalSourceId tag is...							
schema	<p>Displays the external source system ID.</p> <div data-bbox="808 1050 1216 1134" style="border: 1px solid black; padding: 2px;"> <p><b>Note:</b> The system refers the value from within the <b>headerData</b> tag.</p> </div>							
headerData	<p>Used to specify the external source system ID.</p>							

Tag Name	Tag Description	Mandatory (Yes or No)																		
characteristics	<p>You can use this tag within the following tags:</p> <table border="1" data-bbox="602 302 1227 1262"> <thead> <tr> <th data-bbox="602 302 894 386">If this tag is used within...</th> <th data-bbox="894 302 1227 386">Then the purpose of the characteristics tag is...</th> </tr> </thead> <tbody> <tr> <td data-bbox="602 386 894 495">schema</td> <td data-bbox="894 386 1227 495">Used to specify a list of characteristics for the health care inbound message.</td> </tr> <tr> <td data-bbox="602 495 894 611">personData</td> <td data-bbox="894 495 1227 611">Used to specify a list of characteristics for the person.</td> </tr> <tr> <td data-bbox="602 611 894 726">relatedPersons</td> <td data-bbox="894 611 1227 726">Used to specify a list of characteristics for the person to person relationship.</td> </tr> <tr> <td data-bbox="602 726 894 842">memberData</td> <td data-bbox="894 726 1227 842">Used to specify a list of characteristics for the membership.</td> </tr> <tr> <td data-bbox="602 842 894 957">billableChargeData</td> <td data-bbox="894 842 1227 957">Used to specify a list of characteristics for the billable charge.</td> </tr> <tr> <td data-bbox="602 957 894 1073">accountData</td> <td data-bbox="894 957 1227 1073">Used to specify a list of characteristics for the account.</td> </tr> <tr> <td data-bbox="602 1073 894 1188">policyData</td> <td data-bbox="894 1073 1227 1188">Used to specify a list of characteristics for the policy.</td> </tr> <tr> <td data-bbox="602 1188 894 1262">planData</td> <td data-bbox="894 1188 1227 1262">Used to specify a list of characteristics for the policy plan.</td> </tr> </tbody> </table>	If this tag is used within...	Then the purpose of the characteristics tag is...	schema	Used to specify a list of characteristics for the health care inbound message.	personData	Used to specify a list of characteristics for the person.	relatedPersons	Used to specify a list of characteristics for the person to person relationship.	memberData	Used to specify a list of characteristics for the membership.	billableChargeData	Used to specify a list of characteristics for the billable charge.	accountData	Used to specify a list of characteristics for the account.	policyData	Used to specify a list of characteristics for the policy.	planData	Used to specify a list of characteristics for the policy plan.	No
If this tag is used within...	Then the purpose of the characteristics tag is...																			
schema	Used to specify a list of characteristics for the health care inbound message.																			
personData	Used to specify a list of characteristics for the person.																			
relatedPersons	Used to specify a list of characteristics for the person to person relationship.																			
memberData	Used to specify a list of characteristics for the membership.																			
billableChargeData	Used to specify a list of characteristics for the billable charge.																			
accountData	Used to specify a list of characteristics for the account.																			
policyData	Used to specify a list of characteristics for the policy.																			
planData	Used to specify a list of characteristics for the policy plan.																			
inboundMessageCharacteristic	Used to specify a characteristic for the health care inbound message.	No																		
adhocCharacteristicValue	Used to specify the value for the adhoc characteristic type.	Yes (Conditional) <table border="1" data-bbox="1247 1430 1463 1671"> <tr> <td data-bbox="1247 1430 1463 1671"> <b>Note:</b> This data is required while defining or editing an adhoc characteristic of the health care inbound message.             </td> </tr> </table>	<b>Note:</b> This data is required while defining or editing an adhoc characteristic of the health care inbound message.																	
<b>Note:</b> This data is required while defining or editing an adhoc characteristic of the health care inbound message.																				

Tag Name	Tag Description	Mandatory (Yes or No)						
characteristicType	You can use this tag within the following tags:	Yes (Conditional)						
	<table border="1"> <thead> <tr> <th data-bbox="602 304 954 441">If this tag is used within...</th> <th data-bbox="954 304 1227 441">Then the purpose of the characteristicType tag is...</th> </tr> </thead> <tbody> <tr> <td data-bbox="602 441 954 751">inboundMessageCharacteristic</td> <td data-bbox="954 441 1227 751">Used to specify the characteristic type. Here, you must specify a characteristic type where the characteristic entity is set to <b>Inbound Message</b>.</td> </tr> <tr> <td data-bbox="602 751 954 2020">characteristicsList</td> <td data-bbox="954 751 1227 2020">           Used to specify the characteristic type. If you are defining a characteristic for a:           <ul style="list-style-type: none"> <li>• <b>Person</b> - You must specify a characteristic type where the characteristic entity is set to <b>Person</b>.</li> <li>• <b>Related Person</b> - You must specify a characteristic type where the characteristic entity is set to <b>Person to Person</b>.</li> <li>• <b>Membership</b> - You must specify a characteristic type where the characteristic entity is set to <b>Membership</b>.</li> <li>• <b>Membership Person</b> - You must specify a characteristic type where the characteristic entity is set to <b>Membership Person</b>.</li> </ul> </td> </tr> </tbody> </table>	If this tag is used within...	Then the purpose of the characteristicType tag is...	inboundMessageCharacteristic	Used to specify the characteristic type. Here, you must specify a characteristic type where the characteristic entity is set to <b>Inbound Message</b> .	characteristicsList	Used to specify the characteristic type. If you are defining a characteristic for a: <ul style="list-style-type: none"> <li>• <b>Person</b> - You must specify a characteristic type where the characteristic entity is set to <b>Person</b>.</li> <li>• <b>Related Person</b> - You must specify a characteristic type where the characteristic entity is set to <b>Person to Person</b>.</li> <li>• <b>Membership</b> - You must specify a characteristic type where the characteristic entity is set to <b>Membership</b>.</li> <li>• <b>Membership Person</b> - You must specify a characteristic type where the characteristic entity is set to <b>Membership Person</b>.</li> </ul>	<div style="border: 1px solid black; padding: 5px;"> <p><b>Note:</b> This data is required while defining or editing a characteristic of the respective entity.</p> </div>
	If this tag is used within...	Then the purpose of the characteristicType tag is...						
inboundMessageCharacteristic	Used to specify the characteristic type. Here, you must specify a characteristic type where the characteristic entity is set to <b>Inbound Message</b> .							
characteristicsList	Used to specify the characteristic type. If you are defining a characteristic for a: <ul style="list-style-type: none"> <li>• <b>Person</b> - You must specify a characteristic type where the characteristic entity is set to <b>Person</b>.</li> <li>• <b>Related Person</b> - You must specify a characteristic type where the characteristic entity is set to <b>Person to Person</b>.</li> <li>• <b>Membership</b> - You must specify a characteristic type where the characteristic entity is set to <b>Membership</b>.</li> <li>• <b>Membership Person</b> - You must specify a characteristic type where the characteristic entity is set to <b>Membership Person</b>.</li> </ul>							



Tag Name	Tag Description		Mandatory (Yes or No)
	If this tag is used within...	Then the purpose of the characteristicType tag is...	
		<ul style="list-style-type: none"> <li>• <b>Billable Charge</b> - You must specify a characteristic type where the characteristic entity is set to <b>Billable Charge</b>.</li> <li>• <b>Account</b> - You must specify a characteristic type where the characteristic entity is set to <b>Account</b>.</li> <li>• <b>Policy</b> - You must specify a characteristic type where the characteristic entity is set to <b>Policy</b>.</li> <li>• <b>Policy Plan</b> - You must specify a characteristic type where the characteristic entity is set to <b>Policy Plan</b>.</li> </ul>	

Tag Name	Tag Description	Mandatory (Yes or No)								
effectiveDate	<p>You can use this tag within the following tags:</p> <table border="1" data-bbox="602 302 1227 1171"> <thead> <tr> <th data-bbox="602 302 943 417">If this tag is used within...</th> <th data-bbox="943 302 1227 417">Then the purpose of the effectiveDate tag is...</th> </tr> </thead> <tbody> <tr> <td data-bbox="602 417 943 594">inboundMessageCharacteristic</td> <td data-bbox="943 417 1227 594">Used to specify the date from when the characteristic is effective for the health care inbound message.</td> </tr> <tr> <td data-bbox="602 594 943 961">characteristicsList</td> <td data-bbox="943 594 1227 961">Used to specify the date from when the characteristic is effective for the respective entity (i.e. person, person to person relationship, membership, member person, billable charge, account, policy, or policy plan).</td> </tr> <tr> <td data-bbox="602 961 943 1171">billLevelParameters</td> <td data-bbox="943 961 1227 1171">Used to specify the date from when the derivation and pricing parameters are effective for the bill group.</td> </tr> </tbody> </table> <p data-bbox="602 1192 1227 1276"><b>Note:</b> You must specify the date in the YYYY-MM-DD format.</p>	If this tag is used within...	Then the purpose of the effectiveDate tag is...	inboundMessageCharacteristic	Used to specify the date from when the characteristic is effective for the health care inbound message.	characteristicsList	Used to specify the date from when the characteristic is effective for the respective entity (i.e. person, person to person relationship, membership, member person, billable charge, account, policy, or policy plan).	billLevelParameters	Used to specify the date from when the derivation and pricing parameters are effective for the bill group.	<p>Yes (Conditional)</p> <p data-bbox="1247 296 1466 590"><b>Note:</b> This data is required while defining or editing a characteristic of the respective entity or while defining the derivation and pricing parameters for the bill group.</p>
If this tag is used within...	Then the purpose of the effectiveDate tag is...									
inboundMessageCharacteristic	Used to specify the date from when the characteristic is effective for the health care inbound message.									
characteristicsList	Used to specify the date from when the characteristic is effective for the respective entity (i.e. person, person to person relationship, membership, member person, billable charge, account, policy, or policy plan).									
billLevelParameters	Used to specify the date from when the derivation and pricing parameters are effective for the bill group.									
characteristicValue	<p>You can use this tag within the following tags:</p> <table border="1" data-bbox="602 1362 1227 1738"> <thead> <tr> <th data-bbox="602 1362 943 1514">If this tag is used within...</th> <th data-bbox="943 1362 1227 1514">Then the purpose of the characteristicValue tag is...</th> </tr> </thead> <tbody> <tr> <td data-bbox="602 1514 943 1625">inboundMessageCharacteristic</td> <td data-bbox="943 1514 1227 1625">Used to specify the value for the predefined characteristic type.</td> </tr> <tr> <td data-bbox="602 1625 943 1738">characteristicsList</td> <td data-bbox="943 1625 1227 1738">Used to specify the value for the characteristic type.</td> </tr> </tbody> </table>	If this tag is used within...	Then the purpose of the characteristicValue tag is...	inboundMessageCharacteristic	Used to specify the value for the predefined characteristic type.	characteristicsList	Used to specify the value for the characteristic type.	<p>Yes (Conditional)</p> <p data-bbox="1247 1356 1466 1528"><b>Note:</b> This data is required while defining or editing a characteristic of the respective entity.</p>		
If this tag is used within...	Then the purpose of the characteristicValue tag is...									
inboundMessageCharacteristic	Used to specify the value for the predefined characteristic type.									
characteristicsList	Used to specify the value for the characteristic type.									
customerStructureMessage	Used to specify the details of the customer including the header information for the health care inbound message.	Yes								

Tag Name	Tag Description	Mandatory (Yes or No)
characteristicValueForeignKey1	Used to specify the first value for the foreign key characteristic type.	Yes (Conditional) <b>Note:</b> This data is required while defining or editing a foreign key characteristic of the health care inbound message.
characteristicValueFK2	Used to specify the second value for the foreign key characteristic type.	No
characteristicValueFK3	Used to specify the third value for the foreign key characteristic type.	No
characteristicValueFK4	Used to specify the fourth value for the foreign key characteristic type.	No
characteristicValueFK5	Used to specify the fifth value for the foreign key characteristic type.	No
headerData	Used to specify the header information for the health care inbound message.	Yes
personData	Used to specify the details of the parent customer, bill group, or member person.	Yes (Conditional) <b>Note:</b> This data is required while defining or editing a person.

Tag Name	Tag Description	Mandatory (Yes or No)																
sequence	<p>You can use this tag within the following tags:</p> <table border="1" data-bbox="602 302 1227 1440"> <thead> <tr> <th data-bbox="602 302 894 386">If this tag is used within...</th> <th data-bbox="894 302 1227 386">Then the purpose of the sequence tag is...</th> </tr> </thead> <tbody> <tr> <td data-bbox="602 386 894 501">personData</td> <td data-bbox="894 386 1227 501">Used to indicate the order in which the person should be created in the system.</td> </tr> <tr> <td data-bbox="602 501 894 648">personName</td> <td data-bbox="894 501 1227 648">Used to indicate the order in which the person name should be displayed in the user interface.</td> </tr> <tr> <td data-bbox="602 648 894 795">billLevelParameters</td> <td data-bbox="894 648 1227 795">Used to indicate the order in which the derivation and pricing parameters should be created for the bill group.</td> </tr> <tr> <td data-bbox="602 795 894 942">billableChargeData</td> <td data-bbox="894 795 1227 942">Used to indicate the order in which the billable charge should be created for the membership.</td> </tr> <tr> <td data-bbox="602 942 894 1089">baseRate</td> <td data-bbox="894 942 1227 1089">Used to indicate the order in which the price component should be created using the given base rate information.</td> </tr> <tr> <td data-bbox="602 1089 894 1268">pricingParameter</td> <td data-bbox="894 1089 1227 1268">Used to indicate the order in which the pricing eligibility criteria should be created using the parameter information.</td> </tr> <tr> <td data-bbox="602 1268 894 1440">modifierInformation</td> <td data-bbox="894 1268 1227 1440">Used to indicate the order in which the pricing eligibility criteria should be created using the modifier information.</td> </tr> </tbody> </table>	If this tag is used within...	Then the purpose of the sequence tag is...	personData	Used to indicate the order in which the person should be created in the system.	personName	Used to indicate the order in which the person name should be displayed in the user interface.	billLevelParameters	Used to indicate the order in which the derivation and pricing parameters should be created for the bill group.	billableChargeData	Used to indicate the order in which the billable charge should be created for the membership.	baseRate	Used to indicate the order in which the price component should be created using the given base rate information.	pricingParameter	Used to indicate the order in which the pricing eligibility criteria should be created using the parameter information.	modifierInformation	Used to indicate the order in which the pricing eligibility criteria should be created using the modifier information.	<p>Yes (Conditional)</p> <div data-bbox="1248 296 1466 470" style="border: 1px solid black; padding: 2px;"> <p><b>Note:</b> This data is required while defining or editing the respective information.</p> </div>
If this tag is used within...	Then the purpose of the sequence tag is...																	
personData	Used to indicate the order in which the person should be created in the system.																	
personName	Used to indicate the order in which the person name should be displayed in the user interface.																	
billLevelParameters	Used to indicate the order in which the derivation and pricing parameters should be created for the bill group.																	
billableChargeData	Used to indicate the order in which the billable charge should be created for the membership.																	
baseRate	Used to indicate the order in which the price component should be created using the given base rate information.																	
pricingParameter	Used to indicate the order in which the pricing eligibility criteria should be created using the parameter information.																	
modifierInformation	Used to indicate the order in which the pricing eligibility criteria should be created using the modifier information.																	
personType	<p>Used to indicate the type of person. The valid values are:</p> <ul style="list-style-type: none"> <li>• <b>B</b> - Indicates that the person is a business owner.</li> <li>• <b>BG</b> - Indicates that the person is a bill group.</li> <li>• <b>G</b> - Indicates that the person is a group owner.</li> <li>• <b>K</b> - Indicates that the person is a broker.</li> <li>• <b>P</b> - Indicates that the person is an individual.</li> <li>• <b>PG</b> - Indicates that the person is a parent customer.</li> </ul> <div data-bbox="602 1808 1227 1919" style="border: 1px solid black; padding: 2px;"> <p><b>Note:</b> You must specify a value which is already defined in the <b>PER_OR_BUS_FLG</b> lookup field. It must be in the <b>Active</b> status.</p> </div>	<p>Yes (Conditional)</p> <div data-bbox="1248 1520 1466 1665" style="border: 1px solid black; padding: 2px;"> <p><b>Note:</b> This data is required while defining or editing a person.</p> </div>																

Tag Name	Tag Description	Mandatory (Yes or No)						
personName	Used to specify a list of names for the person.	Yes (Conditional) <b>Note:</b> This data is required while defining a person.						
entityName	Used to specify the name of the person.	Yes (Conditional) <b>Note:</b> This data is required while defining a person.						
nameType	Used to indicate the type of name. <b>Note:</b> You must specify a value which is already defined in the <b>NAME_TYPE_FLG</b> lookup field. It must be in the <b>Active</b> status.	Yes (Conditional) <b>Note:</b> This data is required while defining a person.						
identifiers	<p>You can use this tag within the following tags:</p> <table border="1" data-bbox="602 873 1227 1188"> <thead> <tr> <th data-bbox="602 873 894 957">If this tag is used within...</th> <th data-bbox="894 873 1227 957">Then the purpose of the identifiers tag is...</th> </tr> </thead> <tbody> <tr> <td data-bbox="602 957 894 1073">personData</td> <td data-bbox="894 957 1227 1073">Used to specify the identification details for the person.</td> </tr> <tr> <td data-bbox="602 1073 894 1188">accountData</td> <td data-bbox="894 1073 1227 1188">Used to specify the identification details for the account.</td> </tr> </tbody> </table> <p><b>Note:</b> You must specify one primary identifier for a person and account.</p>	If this tag is used within...	Then the purpose of the identifiers tag is...	personData	Used to specify the identification details for the person.	accountData	Used to specify the identification details for the account.	Yes (Conditional) <b>Note:</b> This data is required while defining or editing the respective information.
If this tag is used within...	Then the purpose of the identifiers tag is...							
personData	Used to specify the identification details for the person.							
accountData	Used to specify the identification details for the account.							

Tag Name	Tag Description	Mandatory (Yes or No)												
idType	<p>You can use this tag within the following tags:</p> <table border="1" data-bbox="602 302 1227 795"> <thead> <tr> <th data-bbox="602 302 894 386">If this tag is used within...</th> <th data-bbox="894 302 1227 386">Then the purpose of the idType tag is...</th> </tr> </thead> <tbody> <tr> <td data-bbox="602 386 894 470">identifiers</td> <td data-bbox="894 386 1227 470">Used to specify the person or account identifier type.</td> </tr> <tr> <td data-bbox="602 470 894 554">relatedPersons</td> <td data-bbox="894 470 1227 554">Used to specify the person identifier type.</td> </tr> <tr> <td data-bbox="602 554 894 638">mainSubscriber</td> <td data-bbox="894 554 1227 638">Used to specify the person identifier type.</td> </tr> <tr> <td data-bbox="602 638 894 722">accountPerson</td> <td data-bbox="894 638 1227 722">Used to specify the person identifier type.</td> </tr> <tr> <td data-bbox="602 722 894 795">policyPersons</td> <td data-bbox="894 722 1227 795">Used to specify the person identifier type.</td> </tr> </tbody> </table> <p data-bbox="602 821 1227 898"><b>Note:</b> You must specify a person or account identifier type which is already defined in the system.</p>	If this tag is used within...	Then the purpose of the idType tag is...	identifiers	Used to specify the person or account identifier type.	relatedPersons	Used to specify the person identifier type.	mainSubscriber	Used to specify the person identifier type.	accountPerson	Used to specify the person identifier type.	policyPersons	Used to specify the person identifier type.	<p>Yes (Conditional)</p> <p data-bbox="1252 302 1468 422"><b>Note:</b> This data is required in the following scenarios:</p> <ul data-bbox="1276 443 1468 1367" style="list-style-type: none"> <li>• While defining or editing the identification details of a person and account.</li> <li>• While defining or editing a person to person relationship.</li> <li>• While defining or editing the membership information of a person.</li> <li>• While linking an account to another person.</li> <li>• While associating a person with a policy.</li> </ul>
If this tag is used within...	Then the purpose of the idType tag is...													
identifiers	Used to specify the person or account identifier type.													
relatedPersons	Used to specify the person identifier type.													
mainSubscriber	Used to specify the person identifier type.													
accountPerson	Used to specify the person identifier type.													
policyPersons	Used to specify the person identifier type.													

Tag Name	Tag Description	Mandatory (Yes or No)												
idValue	<p>You can use this tag within the following tags:</p> <table border="1" data-bbox="602 302 1222 953"> <thead> <tr> <th data-bbox="602 302 894 380">If this tag is used within...</th> <th data-bbox="894 302 1222 380">Then the purpose of the idValue tag is...</th> </tr> </thead> <tbody> <tr> <td data-bbox="602 380 894 464">identifiers</td> <td data-bbox="894 380 1222 464">Used to specify the person or account identifier.</td> </tr> <tr> <td data-bbox="602 464 894 611">relatedPersons</td> <td data-bbox="894 464 1222 611">Used to indicate the person with whom you want to establish the person to person relationship.</td> </tr> <tr> <td data-bbox="602 611 894 726">mainSubscriber</td> <td data-bbox="894 611 1222 726">Used to indicate the person who is the main subscriber of the membership.</td> </tr> <tr> <td data-bbox="602 726 894 842">accountPerson</td> <td data-bbox="894 726 1222 842">Used to indicate the person to whom you want to link the account.</td> </tr> <tr> <td data-bbox="602 842 894 953">policyPersons</td> <td data-bbox="894 842 1222 953">Used to indicate the person to whom you want to associate the policy.</td> </tr> </tbody> </table>	If this tag is used within...	Then the purpose of the idValue tag is...	identifiers	Used to specify the person or account identifier.	relatedPersons	Used to indicate the person with whom you want to establish the person to person relationship.	mainSubscriber	Used to indicate the person who is the main subscriber of the membership.	accountPerson	Used to indicate the person to whom you want to link the account.	policyPersons	Used to indicate the person to whom you want to associate the policy.	<p>Yes (Conditional)</p> <div data-bbox="1248 296 1466 468" style="border: 1px solid black; padding: 2px;"> <p><b>Note:</b> This data is required while defining or editing the respective information.</p> </div>
If this tag is used within...	Then the purpose of the idValue tag is...													
identifiers	Used to specify the person or account identifier.													
relatedPersons	Used to indicate the person with whom you want to establish the person to person relationship.													
mainSubscriber	Used to indicate the person who is the main subscriber of the membership.													
accountPerson	Used to indicate the person to whom you want to link the account.													
policyPersons	Used to indicate the person to whom you want to associate the policy.													
isPrimary	<p>Used to indicate whether the person or account identifier is a primary identifier. The valid values are:</p> <ul style="list-style-type: none"> <li>• Y</li> <li>• N</li> </ul> <div data-bbox="602 1163 1222 1245" style="border: 1px solid black; padding: 2px;"> <p><b>Note:</b> If you do not specify the value, by default, it is set to N.</p> </div>	No												
division	<p>You can use this tag within the following tags:</p> <table border="1" data-bbox="602 1337 1222 1612"> <thead> <tr> <th data-bbox="602 1337 894 1415">If this tag is used within...</th> <th data-bbox="894 1337 1222 1415">Then the purpose of the division tag is...</th> </tr> </thead> <tbody> <tr> <td data-bbox="602 1415 894 1499">personData</td> <td data-bbox="894 1415 1222 1499">Used to indicate the division to which the person belongs.</td> </tr> <tr> <td data-bbox="602 1499 894 1612">accountData</td> <td data-bbox="894 1499 1222 1612">Used to indicate the division to which the account belongs.</td> </tr> </tbody> </table> <div data-bbox="602 1640 1222 1717" style="border: 1px solid black; padding: 2px;"> <p><b>Note:</b> You must specify a division which is already defined in the system.</p> </div>	If this tag is used within...	Then the purpose of the division tag is...	personData	Used to indicate the division to which the person belongs.	accountData	Used to indicate the division to which the account belongs.	No						
If this tag is used within...	Then the purpose of the division tag is...													
personData	Used to indicate the division to which the person belongs.													
accountData	Used to indicate the division to which the account belongs.													
birthDate	<p>Used to specify the date when the person was born.</p> <div data-bbox="602 1797 1222 1875" style="border: 1px solid black; padding: 2px;"> <p><b>Note:</b> You must specify the date in the YYYY-MM-DD format.</p> </div>	No												

Tag Name	Tag Description	Mandatory (Yes or No)						
sinceDate	<p>Used to specify the date when the person's record is created in the system. This is purely informational.</p> <p><b>Note:</b> You must specify the date in the YYYY-MM-DD format.</p>	No						
address	<p>You can use this tag within the following tags:</p> <table border="1" data-bbox="602 491 1227 741"> <thead> <tr> <th data-bbox="602 491 894 575">If this tag is used within...</th> <th data-bbox="894 491 1227 575">Then the purpose of the address tag is...</th> </tr> </thead> <tbody> <tr> <td data-bbox="602 575 894 659">personData</td> <td data-bbox="894 575 1227 659">Used to specify the address of the person.</td> </tr> <tr> <td data-bbox="602 659 894 741">accountData</td> <td data-bbox="894 659 1227 741">Used to specify the address of the account.</td> </tr> </tbody> </table>	If this tag is used within...	Then the purpose of the address tag is...	personData	Used to specify the address of the person.	accountData	Used to specify the address of the account.	<p>Yes (Conditional)</p> <p><b>Note:</b> This data is required while defining or editing the address of the respective entity.</p>
If this tag is used within...	Then the purpose of the address tag is...							
personData	Used to specify the address of the person.							
accountData	Used to specify the address of the account.							
addressEffDate	<p>Used to specify the date from when the address is effective.</p> <p><b>Note:</b> You must specify the date in the YYYY-MM-DD format. If you do not specify the date, by default, the system sets the effective date to the date when the address is created in the system through the health care inbound message.</p>	<p>Yes (Conditional)</p> <p><b>Note:</b> This data is required while editing the address of a person or account.</p>						
addressType	<p>Used to indicate the type of address. The valid values are:</p> <ul style="list-style-type: none"> <li>• <b>MAIN</b> - Indicates that the address is the person's mailing address. You can use this address type while specifying the address for the person and account.</li> <li>• <b>SEAS</b> - Indicates that the address is the person's seasonal address. You can use this address type while specifying the address for the person.</li> <li>• <b>OVRD</b> - Indicates that the address is the account's override address. You can use this address type while specifying the address for the account.</li> </ul> <p><b>Note:</b> If you do not specify the address type, by default, it is set to <b>MAIN</b>. You must specify an address type which is already defined in the <b>ADDRESS_TYPE_FLG</b> lookup field. It must be in the <b>Active</b> status.</p>	<p>Yes (Conditional)</p> <p><b>Note:</b> This data is required while editing the address of a person or account.</p>						
mailingName	<p>Used to specify the name using which the person should be addressed in the mail communication. The system also uses the mailing name in the bills, letters, quotes, and statements.</p>	No						



Tag Name	Tag Description	Mandatory (Yes or No)						
address1	<p>You can use this tag within the following tags:</p> <table border="1" data-bbox="602 300 1227 674"> <thead> <tr> <th data-bbox="602 300 894 384">If this tag is used within...</th> <th data-bbox="894 300 1227 384">Then the purpose of the address1 tag is...</th> </tr> </thead> <tbody> <tr> <td data-bbox="602 384 894 527">address</td> <td data-bbox="894 384 1227 527">Used to specify the first line of the address. It may contain details, such as the house number.</td> </tr> <tr> <td data-bbox="602 527 894 674">personAddressOverride</td> <td data-bbox="894 527 1227 674">Used to specify the first line of the address. It may contain details, such as the house number.</td> </tr> </tbody> </table>	If this tag is used within...	Then the purpose of the address1 tag is...	address	Used to specify the first line of the address. It may contain details, such as the house number.	personAddressOverride	Used to specify the first line of the address. It may contain details, such as the house number.	<p>Yes (Conditional)</p> <div data-bbox="1247 289 1466 464" style="border: 1px solid black; padding: 2px;"> <p><b>Note:</b> This data is required while defining and editing the address of a person and account.</p> </div>
If this tag is used within...	Then the purpose of the address1 tag is...							
address	Used to specify the first line of the address. It may contain details, such as the house number.							
personAddressOverride	Used to specify the first line of the address. It may contain details, such as the house number.							
address2	<p>You can use this tag within the following tags:</p> <table border="1" data-bbox="602 768 1227 1142"> <thead> <tr> <th data-bbox="602 768 894 852">If this tag is used within...</th> <th data-bbox="894 768 1227 852">Then the purpose of the address2 tag is...</th> </tr> </thead> <tbody> <tr> <td data-bbox="602 852 894 995">address</td> <td data-bbox="894 852 1227 995">Used to specify the second line of the address. It may contain details, such as the apartment name.</td> </tr> <tr> <td data-bbox="602 995 894 1142">personAddressOverride</td> <td data-bbox="894 995 1227 1142">Used to specify the second line of the address. It may contain details, such as the apartment name.</td> </tr> </tbody> </table>	If this tag is used within...	Then the purpose of the address2 tag is...	address	Used to specify the second line of the address. It may contain details, such as the apartment name.	personAddressOverride	Used to specify the second line of the address. It may contain details, such as the apartment name.	No
If this tag is used within...	Then the purpose of the address2 tag is...							
address	Used to specify the second line of the address. It may contain details, such as the apartment name.							
personAddressOverride	Used to specify the second line of the address. It may contain details, such as the apartment name.							
address3	<p>You can use this tag within the following tags:</p> <table border="1" data-bbox="602 1236 1227 1610"> <thead> <tr> <th data-bbox="602 1236 894 1320">If this tag is used within...</th> <th data-bbox="894 1236 1227 1320">Then the purpose of the address3 tag is...</th> </tr> </thead> <tbody> <tr> <td data-bbox="602 1320 894 1463">address</td> <td data-bbox="894 1320 1227 1463">Used to specify the third line of the address. It may contain details, such as the street name.</td> </tr> <tr> <td data-bbox="602 1463 894 1610">personAddressOverride</td> <td data-bbox="894 1463 1227 1610">Used to specify the third line of the address. It may contain details, such as the street name.</td> </tr> </tbody> </table>	If this tag is used within...	Then the purpose of the address3 tag is...	address	Used to specify the third line of the address. It may contain details, such as the street name.	personAddressOverride	Used to specify the third line of the address. It may contain details, such as the street name.	No
If this tag is used within...	Then the purpose of the address3 tag is...							
address	Used to specify the third line of the address. It may contain details, such as the street name.							
personAddressOverride	Used to specify the third line of the address. It may contain details, such as the street name.							

Tag Name	Tag Description	Mandatory (Yes or No)						
address4	<p>You can use this tag within the following tags:</p> <table border="1"> <thead> <tr> <th>If this tag is used within...</th> <th>Then the purpose of the address4 tag is...</th> </tr> </thead> <tbody> <tr> <td>address</td> <td>Used to specify the fourth line of the address. It may contain the landmark details.</td> </tr> <tr> <td>personAddressOverride</td> <td>Used to specify the fourth line of the address. It may contain the landmark details.</td> </tr> </tbody> </table>	If this tag is used within...	Then the purpose of the address4 tag is...	address	Used to specify the fourth line of the address. It may contain the landmark details.	personAddressOverride	Used to specify the fourth line of the address. It may contain the landmark details.	No
If this tag is used within...	Then the purpose of the address4 tag is...							
address	Used to specify the fourth line of the address. It may contain the landmark details.							
personAddressOverride	Used to specify the fourth line of the address. It may contain the landmark details.							
city	<p>You can use this tag within the following tags:</p> <table border="1"> <thead> <tr> <th>If this tag is used within...</th> <th>Then the purpose of the city tag is...</th> </tr> </thead> <tbody> <tr> <td>address</td> <td>Used to specify the city name.</td> </tr> <tr> <td>personAddressOverride</td> <td>Used to specify the city name.</td> </tr> </tbody> </table>	If this tag is used within...	Then the purpose of the city tag is...	address	Used to specify the city name.	personAddressOverride	Used to specify the city name.	No
If this tag is used within...	Then the purpose of the city tag is...							
address	Used to specify the city name.							
personAddressOverride	Used to specify the city name.							
state	<p>You can use this tag within the following tags:</p> <table border="1"> <thead> <tr> <th>If this tag is used within...</th> <th>Then the purpose of the state tag is...</th> </tr> </thead> <tbody> <tr> <td>address</td> <td>Used to indicate the state where the city is located.</td> </tr> <tr> <td>personAddressOverride</td> <td>Used to indicate the state where the city is located.</td> </tr> </tbody> </table>	If this tag is used within...	Then the purpose of the state tag is...	address	Used to indicate the state where the city is located.	personAddressOverride	Used to indicate the state where the city is located.	No
If this tag is used within...	Then the purpose of the state tag is...							
address	Used to indicate the state where the city is located.							
personAddressOverride	Used to indicate the state where the city is located.							
zip	Used to specify the zip code of the address.	No						
country	<p>You can use this tag within the following tags:</p> <table border="1"> <thead> <tr> <th>If this tag is used within...</th> <th>Then the purpose of the country tag is...</th> </tr> </thead> <tbody> <tr> <td>address</td> <td>Used to indicate the country where the person or account is located.</td> </tr> <tr> <td>personAddressOverride</td> <td>Used to indicate the country where the person is located.</td> </tr> </tbody> </table>	If this tag is used within...	Then the purpose of the country tag is...	address	Used to indicate the country where the person or account is located.	personAddressOverride	Used to indicate the country where the person is located.	Yes (Conditional) <div style="border: 1px solid black; padding: 5px; margin-top: 10px;"> <b>Note:</b> This data is required while defining or editing the address of a person or account.           </div>
If this tag is used within...	Then the purpose of the country tag is...							
address	Used to indicate the country where the person or account is located.							
personAddressOverride	Used to indicate the country where the person is located.							
email	Used to specify the e-mail ID of the person.	No						
overrideMailingName1	Used to specify the name using which you want to override the person's mailing name.	No						

Tag Name	Tag Description	Mandatory (Yes or No)
overrideMailingName2	Used to specify the name using which you want to override the person's override mailing name 1.	No
overrideMailingName3	Used to specify the name using which you want to override the person's override mailing name 2.	No
phones	Used to specify the phone details of the person.	Yes (Conditional) <b>Note:</b> This data is required while defining or editing the phone details of a person.
phoneType	Used to indicate the type of phone. <b>Note:</b> You must specify a phone type which is already defined in the system.	Yes (Conditional) <b>Note:</b> This data is required while defining or editing the phone details of a person.
phoneValue	Used to specify the phone number of the person.	Yes (Conditional) <b>Note:</b> This data is required while defining or editing the phone details of a person.
relatedPersons	Used to list other persons with whom you want to establish the person's relationship.	Yes (Conditional) <b>Note:</b> This data is required while defining or editing a person to person relationship.
personRelationshipType	Used to indicate how the other person is related to the person. <b>Note:</b> You must specify a person relationship type which is already defined in the system. If you have specified a parent customer as the related person for a bill group, the system, by default, uses the person relationship type which is specified in the <b>Person Relationship Type</b> option type of the <b>C1-ASOBLNG</b> feature configuration. It does not considers the value specified in this tag.	Yes (Conditional) <b>Note:</b> This data is required while creating relationship between a bill group and person whose the person type is not <b>Parent Customer</b> .

Tag Name	Tag Description	Mandatory (Yes or No)																		
startDate	<p>You can use this tag within the following tags:</p> <table border="1" data-bbox="602 302 1227 1266"> <thead> <tr> <th data-bbox="602 302 894 386">If this tag is used within...</th> <th data-bbox="894 302 1227 386">Then the purpose of the startDate tag is...</th> </tr> </thead> <tbody> <tr> <td data-bbox="602 386 894 499">relatedPersons</td> <td data-bbox="894 386 1227 499">Used to specify the date from when the other person is related to the person.</td> </tr> <tr> <td data-bbox="602 499 894 613">memberData</td> <td data-bbox="894 499 1227 613">Used to specify the date from when the membership is effective.</td> </tr> <tr> <td data-bbox="602 613 894 726">billableChargeData</td> <td data-bbox="894 613 1227 726">Used to specify the start date of the billable charge.</td> </tr> <tr> <td data-bbox="602 726 894 840">autoPayDetails</td> <td data-bbox="894 726 1227 840">Used to specify the date from when the auto pay instruction is effective.</td> </tr> <tr> <td data-bbox="602 840 894 953">policyData</td> <td data-bbox="894 840 1227 953">Used to specify the date from when the policy is effective.</td> </tr> <tr> <td data-bbox="602 953 894 1066">policyPersons</td> <td data-bbox="894 953 1227 1066">Used to specify the date from when the person is associated with the policy.</td> </tr> <tr> <td data-bbox="602 1066 894 1180">planData</td> <td data-bbox="894 1066 1227 1180">Used to specify the date from when the policy plan is effective.</td> </tr> <tr> <td data-bbox="602 1180 894 1266">pricingRuleData</td> <td data-bbox="894 1180 1227 1266">Used to specify the date from when the pricing rule is effective.</td> </tr> </tbody> </table> <p data-bbox="602 1293 1227 1367"><b>Note:</b> You must specify the date in the YYYY-MM-DD format.</p>	If this tag is used within...	Then the purpose of the startDate tag is...	relatedPersons	Used to specify the date from when the other person is related to the person.	memberData	Used to specify the date from when the membership is effective.	billableChargeData	Used to specify the start date of the billable charge.	autoPayDetails	Used to specify the date from when the auto pay instruction is effective.	policyData	Used to specify the date from when the policy is effective.	policyPersons	Used to specify the date from when the person is associated with the policy.	planData	Used to specify the date from when the policy plan is effective.	pricingRuleData	Used to specify the date from when the pricing rule is effective.	<p>Yes (Conditional)</p> <p data-bbox="1252 296 1468 422"><b>Note:</b> This data is required in the following scenarios:</p> <ul data-bbox="1276 443 1468 968" style="list-style-type: none"> <li>• While defining the respective information.</li> <li>• While editing the membership information of a person.</li> <li>• While editing an auto pay instruction of an account.</li> <li>• While editing a pricing rule.</li> </ul>
If this tag is used within...	Then the purpose of the startDate tag is...																			
relatedPersons	Used to specify the date from when the other person is related to the person.																			
memberData	Used to specify the date from when the membership is effective.																			
billableChargeData	Used to specify the start date of the billable charge.																			
autoPayDetails	Used to specify the date from when the auto pay instruction is effective.																			
policyData	Used to specify the date from when the policy is effective.																			
policyPersons	Used to specify the date from when the person is associated with the policy.																			
planData	Used to specify the date from when the policy plan is effective.																			
pricingRuleData	Used to specify the date from when the pricing rule is effective.																			

Tag Name	Tag Description	Mandatory (Yes or No)																		
endDate	<p>You can use this tag within the following tags:</p> <table border="1" data-bbox="602 302 1227 1234"> <thead> <tr> <th data-bbox="602 302 894 380">If this tag is used within...</th> <th data-bbox="894 302 1227 380">Then the purpose of the endDate tag is...</th> </tr> </thead> <tbody> <tr> <td data-bbox="602 380 894 495">relatedPersons</td> <td data-bbox="894 380 1227 495">Used to specify the date till when the other person is related to the person.</td> </tr> <tr> <td data-bbox="602 495 894 611">memberData</td> <td data-bbox="894 495 1227 611">Used to specify the date till when the membership is effective.</td> </tr> <tr> <td data-bbox="602 611 894 695">billableChargeData</td> <td data-bbox="894 611 1227 695">Used to specify the end date of the billable charge.</td> </tr> <tr> <td data-bbox="602 695 894 810">autoPayDetails</td> <td data-bbox="894 695 1227 810">Used to specify the date till when the auto pay instruction is effective.</td> </tr> <tr> <td data-bbox="602 810 894 894">policyData</td> <td data-bbox="894 810 1227 894">Used to specify the date till when the policy is effective.</td> </tr> <tr> <td data-bbox="602 894 894 999">policyPersons</td> <td data-bbox="894 894 1227 999">Used to specify the date till when the person is associated with the policy.</td> </tr> <tr> <td data-bbox="602 999 894 1115">planData</td> <td data-bbox="894 999 1227 1115">Used to specify the date till when the policy plan is effective.</td> </tr> <tr> <td data-bbox="602 1115 894 1234">pricingRuleData</td> <td data-bbox="894 1115 1227 1234">Used to specify the date till when the pricing rule is effective.</td> </tr> </tbody> </table> <p><b>Note:</b> You must specify the date in the YYYY-MM-DD format.</p>	If this tag is used within...	Then the purpose of the endDate tag is...	relatedPersons	Used to specify the date till when the other person is related to the person.	memberData	Used to specify the date till when the membership is effective.	billableChargeData	Used to specify the end date of the billable charge.	autoPayDetails	Used to specify the date till when the auto pay instruction is effective.	policyData	Used to specify the date till when the policy is effective.	policyPersons	Used to specify the date till when the person is associated with the policy.	planData	Used to specify the date till when the policy plan is effective.	pricingRuleData	Used to specify the date till when the pricing rule is effective.	<p>Yes (Conditional)</p> <p><b>Note:</b> This data is required while editing the membership information of a person.</p>
If this tag is used within...	Then the purpose of the endDate tag is...																			
relatedPersons	Used to specify the date till when the other person is related to the person.																			
memberData	Used to specify the date till when the membership is effective.																			
billableChargeData	Used to specify the end date of the billable charge.																			
autoPayDetails	Used to specify the date till when the auto pay instruction is effective.																			
policyData	Used to specify the date till when the policy is effective.																			
policyPersons	Used to specify the date till when the person is associated with the policy.																			
planData	Used to specify the date till when the policy plan is effective.																			
pricingRuleData	Used to specify the date till when the pricing rule is effective.																			
financialRelationshipSw	<p>Used to indicate whether the other person is financially responsible for the person. The valid values are:</p> <ul style="list-style-type: none"> <li>• true</li> <li>• false</li> </ul> <p><b>Note:</b> If you do not specify the value, by default, it is set to <b>false</b>.</p>	No																		
parentOrChild	<p>Used to indicate whether the other person is parent or child. The valid values are:</p> <ul style="list-style-type: none"> <li>• P</li> <li>• C</li> </ul>	<p>Yes (Conditional)</p> <p><b>Note:</b> This data is required while creating a person to person relationship.</p>																		

Tag Name	Tag Description	Mandatory (Yes or No)						
characteristicsList	<p>You can use this tag within the following tags:</p> <table border="1" data-bbox="602 302 1227 869"> <thead> <tr> <th data-bbox="602 302 971 449">If this tag is used within...</th> <th data-bbox="971 302 1227 449">Then the purpose of the characteristicsList tag is...</th> </tr> </thead> <tbody> <tr> <td data-bbox="602 449 971 751">characteristics</td> <td data-bbox="971 449 1227 751">Used to specify a characteristic for the respective entity (i.e. person, person to person relationship, membership, billable charge, account, policy, or policy plan).</td> </tr> <tr> <td data-bbox="602 751 971 869">membershipPersonCharacteristic</td> <td data-bbox="971 751 1227 869">Used to specify a characteristic for the member person.</td> </tr> </tbody> </table>	If this tag is used within...	Then the purpose of the characteristicsList tag is...	characteristics	Used to specify a characteristic for the respective entity (i.e. person, person to person relationship, membership, billable charge, account, policy, or policy plan).	membershipPersonCharacteristic	Used to specify a characteristic for the member person.	<p>Yes (Conditional)</p> <div data-bbox="1252 296 1463 470" style="border: 1px solid black; padding: 2px;"> <p><b>Note:</b> This data is required while defining or editing a characteristic of the respective entity.</p> </div>
If this tag is used within...	Then the purpose of the characteristicsList tag is...							
characteristics	Used to specify a characteristic for the respective entity (i.e. person, person to person relationship, membership, billable charge, account, policy, or policy plan).							
membershipPersonCharacteristic	Used to specify a characteristic for the member person.							
billLevelParameters	Used to specify the derivation and pricing parameters for the bill group.	No						
billLevelInfo1	<p>Used to specify the employee attribute based on which you want to derive the bill group.</p> <div data-bbox="602 1062 1227 1146" style="border: 1px solid black; padding: 2px;"> <p><b>Note:</b> You must not specify the ampersand (&amp;) character in the value.</p> </div>	<p>Yes (Conditional)</p> <div data-bbox="1252 1031 1463 1241" style="border: 1px solid black; padding: 2px;"> <p><b>Note:</b> This data is required while defining the derivation and pricing parameters for a bill group.</p> </div>						
billLevelInfo2	<p>Used to specify the employee attribute based on which you want to derive the bill group.</p> <div data-bbox="602 1350 1227 1434" style="border: 1px solid black; padding: 2px;"> <p><b>Note:</b> You must not specify the ampersand (&amp;) character in the value.</p> </div>	No						
billLevelInfo3	<p>Used to specify the employee attribute based on which you want to derive the bill group.</p> <div data-bbox="602 1539 1227 1623" style="border: 1px solid black; padding: 2px;"> <p><b>Note:</b> You must not specify the ampersand (&amp;) character in the value.</p> </div>	No						
billLevelInfo4	<p>Used to specify the employee attribute based on which you want to derive the bill group.</p> <div data-bbox="602 1728 1227 1812" style="border: 1px solid black; padding: 2px;"> <p><b>Note:</b> You must not specify the ampersand (&amp;) character in the value.</p> </div>	No						

Tag Name	Tag Description	Mandatory (Yes or No)						
memberData	Used to specify the details of the membership to which the person belongs.	Yes (Conditional) <b>Note:</b> This data is required while defining or editing the membership details of a person.						
memberId	Used to specify the external membership ID.	No						
memberRelationship	Used to indicate how the person is related to the main subscriber. <b>Note:</b> You must specify a contract relationship type which is already defined in the system. If the person is the main subscriber in a membership, you must set the value to <b>SELF</b> .	Yes (Conditional) <b>Note:</b> This data is required while defining or editing the membership details of a person.						
mainSubscriber	Used to indicate the person who is the main subscriber in the membership.	Yes (Conditional) <b>Note:</b> This data is required while defining the membership details for a person.						
policyNumber	You can use this tag within the following tags: <table border="1" data-bbox="602 1192 1227 1478"> <thead> <tr> <th data-bbox="602 1192 894 1276">If this tag is used within...</th> <th data-bbox="894 1192 1227 1276">Then the purpose of the policyNumber tag is...</th> </tr> </thead> <tbody> <tr> <td data-bbox="602 1276 894 1392">memberData</td> <td data-bbox="894 1276 1227 1392">Used to indicate the policy where the policy plan is defined.</td> </tr> <tr> <td data-bbox="602 1392 894 1478">policyData</td> <td data-bbox="894 1392 1227 1478">Used to specify the policy number.</td> </tr> </tbody> </table>	If this tag is used within...	Then the purpose of the policyNumber tag is...	memberData	Used to indicate the policy where the policy plan is defined.	policyData	Used to specify the policy number.	Yes (Conditional) <b>Note:</b> This data is required while defining or editing the respective information.
If this tag is used within...	Then the purpose of the policyNumber tag is...							
memberData	Used to indicate the policy where the policy plan is defined.							
policyData	Used to specify the policy number.							
planNumber	You can use this tag within the following tags: <table border="1" data-bbox="602 1564 1227 1850"> <thead> <tr> <th data-bbox="602 1564 894 1648">If this tag is used within...</th> <th data-bbox="894 1564 1227 1648">Then the purpose of the planNumber tag is...</th> </tr> </thead> <tbody> <tr> <td data-bbox="602 1648 894 1764">memberData</td> <td data-bbox="894 1648 1227 1764">Used to indicate the policy plan where you want to add or edit the membership.</td> </tr> <tr> <td data-bbox="602 1764 894 1850">planData</td> <td data-bbox="894 1764 1227 1850">Used to specify the plan number.</td> </tr> </tbody> </table>	If this tag is used within...	Then the purpose of the planNumber tag is...	memberData	Used to indicate the policy plan where you want to add or edit the membership.	planData	Used to specify the plan number.	Yes (Conditional) <b>Note:</b> This data is required while defining or editing the respective information.
If this tag is used within...	Then the purpose of the planNumber tag is...							
memberData	Used to indicate the policy plan where you want to add or edit the membership.							
planData	Used to specify the plan number.							

Tag Name	Tag Description	Mandatory (Yes or No)						
membershipPersonCharacteristic	Used to specify a list of characteristics for the member person.	No						
billableChargeData	Used to specify the details for a billable charge. Ideally, this piece of information should be specified in the main subscriber details and not in the member person details.	Yes (Conditional) <b>Note:</b> This data is required while defining or editing a billable charge of a membership.						
accountIdType	Used to specify the account identifier type. <b>Note:</b> You must specify an account identifier type which is already defined in the system.	Yes (Conditional) <b>Note:</b> This data is required when the <b>accountIdValue</b> tag contains the account identifier.						
accountIdValue	Used to indicate the account for which you want to create the billable charge.	Yes (Conditional) <b>Note:</b> This data is required when the <b>accountIdType</b> tag contains the account identifier type.						
chargeType	Used to indicate the type of billable charge that you want to create. <b>Note:</b> You must specify a charge type which is already defined in the system.	No						
priceItemCode	You can use this tag within the following tags: <table border="1" data-bbox="602 1371 1227 1713"> <thead> <tr> <th>If this tag is used within...</th> <th>Then the purpose of the priceItemCode tag is...</th> </tr> </thead> <tbody> <tr> <td>billableChargeData</td> <td>Used to indicate the price item for which you want to create the billable charge.</td> </tr> <tr> <td>planData</td> <td>Used to indicate the price item which you want to associate with the policy plan.</td> </tr> </tbody> </table>	If this tag is used within...	Then the purpose of the priceItemCode tag is...	billableChargeData	Used to indicate the price item for which you want to create the billable charge.	planData	Used to indicate the price item which you want to associate with the policy plan.	Yes (Conditional) <b>Note:</b> This data is required while defining or editing a billable charge of a membership.
If this tag is used within...	Then the purpose of the priceItemCode tag is...							
billableChargeData	Used to indicate the price item for which you want to create the billable charge.							
planData	Used to indicate the price item which you want to associate with the policy plan.							



Tag Name	Tag Description	Mandatory (Yes or No)						
description	<p>You can use this tag within the following tags:</p> <table border="1"> <thead> <tr> <th>If this tag is used within...</th> <th>Then the purpose of the description tag is...</th> </tr> </thead> <tbody> <tr> <td>billableChargeData</td> <td>Used to specify the description for the billable charge.</td> </tr> <tr> <td>policyData</td> <td>Used to specify the description for the policy.</td> </tr> </tbody> </table>	If this tag is used within...	Then the purpose of the description tag is...	billableChargeData	Used to specify the description for the billable charge.	policyData	Used to specify the description for the policy.	<p>Yes (Conditional)</p> <p><b>Note:</b> This data is required while defining the respective information.</p>
If this tag is used within...	Then the purpose of the description tag is...							
billableChargeData	Used to specify the description for the billable charge.							
policyData	Used to specify the description for the policy.							
recurringMethod	<p>Used to indicate whether recurring bill segments must be created for the billable charge at the specified intervals. The valid values are:</p> <ul style="list-style-type: none"> <li>• <b>BP</b> - Used when you want to create recurring bill segments at the intervals defined in the bill period.</li> <li>• <b>FR</b> - Used when you want to create recurring bill segments at the set invoice frequency.</li> </ul>	No						
billPeriod	<p>Used to indicate the bill period using which you want to determine the intervals at which the recurring bill segments must be created.</p> <p><b>Note:</b> You must specify a bill period which is already defined in the system.</p>	<p>Yes (Conditional)</p> <p><b>Note:</b> This data is required when the <b>recurringMethod</b> tag contains <b>BP</b>.</p>						
frequency	<p>Used to indicate the invoice frequency at which the recurring bill segments must be created.</p> <p><b>Note:</b> You must specify an invoice frequency which is already defined in the system.</p>	<p>Yes (Conditional)</p> <p><b>Note:</b> This data is required when the <b>recurringMethod</b> tag contains <b>FR</b>.</p>						
billAfterDt	<p>Used to specify the date after which the bill must be generated for the billable charge.</p> <p><b>Note:</b> You must specify the date in the YYYY-MM-DD format.</p>	No						
billableChargeLines	Used to specify the details for a pass through line in the billable charge.	Yes						
descriptionOnBill	Used to specify the information about the pass through line that should appear on the bill.	Yes						

Tag Name	Tag Description	Mandatory (Yes or No)
currencyCode	<p>Used to indicate the currency in which you want to charge the amount.</p> <div data-bbox="602 321 1227 579" style="border: 1px solid black; padding: 5px;"> <p><b>Note:</b> You must specify a currency which is already defined in the system. If you specify a currency other than the account's invoice currency, the system will do the currency conversion if the appropriate exchange rate is available in the system.</p> </div>	Yes
chargeAmount	Used to specify the charge amount.	Yes
showOnBillSw	<p>Used to indicate whether the charge should appear on the person's printed bill. The valid values are:</p> <ul style="list-style-type: none"> <li>• true</li> <li>• false</li> </ul> <div data-bbox="602 835 1227 915" style="border: 1px solid black; padding: 5px;"> <p><b>Note:</b> If you do not specify the value, by default, it is set to <b>true</b>.</p> </div>	No
appearInSummarySw	<p>Used to indicate whether the charge should be included in the summary line. The valid values are:</p> <ul style="list-style-type: none"> <li>• true</li> <li>• false</li> </ul> <div data-bbox="602 1121 1227 1201" style="border: 1px solid black; padding: 5px;"> <p><b>Note:</b> If you do not specify the value, by default, it is set to <b>false</b>.</p> </div>	No
distributionCode	<p>Used to specify the distribution code which indicates the GL account associated with the charge.</p> <div data-bbox="602 1310 1227 1390" style="border: 1px solid black; padding: 5px;"> <p><b>Note:</b> You must specify a distribution code which is already defined in the system.</p> </div>	No
accountData	Used to specify the account details of a person.	<p>Yes (Conditional)</p> <div data-bbox="1252 1472 1464 1612" style="border: 1px solid black; padding: 5px;"> <p><b>Note:</b> This data is required while defining or editing an account.</p> </div>

Tag Name	Tag Description	Mandatory (Yes or No)
accountType	<p>Used to indicate the type of account. This information is stored as a characteristic for the account.</p> <p><b>Note:</b> The value is stored in the characteristic type which is specified in the <b>Invoice Type Characteristic Type</b> option type of the <b>C1-ASOBLNG</b> feature configuration. You must specify a value which is already defined in the predefined characteristic type.</p>	<p>Yes (Conditional)</p> <p><b>Note:</b> This data is required while defining or editing an account.</p>
customerClass	<p>Used to indicate the customer class to which the account belongs.</p> <p><b>Note:</b> You must specify a customer class which is already defined in the system.</p>	<p>Yes (Conditional)</p> <p><b>Note:</b> This data is required while defining an account.</p>
billCycle	<p>Used to indicate the bill cycle for the account.</p> <p><b>Note:</b> You must specify a bill cycle which is already defined in the system.</p>	No
billLeadDays	<p>Used to indicate whether you want to bill the account in advance. Here, you need to specify the number of days which is used to derive the cut-off date for advance billing. If you do not want to bill the account in advance, you must specify the value as zero(0).</p> <p><b>Note:</b> If you do not specify the value, by default, it is set to zero(0).</p>	No
currency	<p>Used to indicate the currency in which you want to bill the account.</p> <p><b>Note:</b> You must specify a currency which is already defined in the system.</p>	<p>Yes (Conditional)</p> <p><b>Note:</b> This data is required while defining an account.</p>
setUpDate	<p>Used to specify the date when the account was first created. This is purely informational.</p> <p><b>Note:</b> You must specify the date in the YYYY-MM-DD format. If you do not specify the value, by default, it is set to the current date.</p>	No

Tag Name	Tag Description	Mandatory (Yes or No)						
acctUsageFlg	<p>Used to indicate the category to which the account belongs. The valid values are:</p> <ul style="list-style-type: none"> <li>• <b>INVC</b> - Indicates that the account will be used to bill charges of the usage accounts.</li> <li>• <b>SETL</b> - Indicates that the account will be used only for settlement purposes.</li> <li>• <b>USAG</b> - Indicates that the account will have its own charges. If the usage account is linked to any construct, the usage account's charges are billed through an invoice account. Otherwise, the usage account is billed individually.</li> </ul> <p><b>Note:</b> If you do not specify the value, by default, it is set to <b>USAG</b>.</p>	No						
comments	<p>You can use this tag within the following tags:</p> <table border="1" data-bbox="602 827 1227 1136"> <thead> <tr> <th data-bbox="602 827 894 911">If this tag is used within...</th> <th data-bbox="894 827 1227 911">Then the purpose of the comments tag is...</th> </tr> </thead> <tbody> <tr> <td data-bbox="602 911 894 1026">accountData</td> <td data-bbox="894 911 1227 1026">Used to specify additional information about the account.</td> </tr> <tr> <td data-bbox="602 1026 894 1136">autoPayDetails</td> <td data-bbox="894 1026 1227 1136">Used to specify additional information about the auto pay instruction.</td> </tr> </tbody> </table>	If this tag is used within...	Then the purpose of the comments tag is...	accountData	Used to specify additional information about the account.	autoPayDetails	Used to specify additional information about the auto pay instruction.	No
If this tag is used within...	Then the purpose of the comments tag is...							
accountData	Used to specify additional information about the account.							
autoPayDetails	Used to specify additional information about the auto pay instruction.							
deferAutoPayDt	Used to specify the date till when you want to hold the automatic payment process for the account.	No						
collectionClass	<p>Used to specify the collection class using which you want to control the account's debt.</p> <p><b>Note:</b> If you do not specify the value, by default, it is set to the collection class which is specified in the customer class of the account. You must specify a collection class which is already defined in the system.</p>	No						

Tag Name	Tag Description	Mandatory (Yes or No)						
billRouteType	<p>You can use this tag within the following tags:</p> <table border="1" data-bbox="602 302 1219 611"> <thead> <tr> <th data-bbox="602 302 894 380">If this tag is used within...</th> <th data-bbox="894 302 1219 380">Then the purpose of the billRouteType tag is...</th> </tr> </thead> <tbody> <tr> <td data-bbox="602 380 894 495">accountData</td> <td data-bbox="894 380 1219 495">Used to indicate how the account's bill must be sent to the main customer.</td> </tr> <tr> <td data-bbox="602 495 894 611">accountPersonRouting</td> <td data-bbox="894 495 1219 611">Used to indicate how the account's bill must be sent to the linked person.</td> </tr> </tbody> </table> <p><b>Note:</b> You must specify a bill route type which is already defined in the system.</p>	If this tag is used within...	Then the purpose of the billRouteType tag is...	accountData	Used to indicate how the account's bill must be sent to the main customer.	accountPersonRouting	Used to indicate how the account's bill must be sent to the linked person.	<p>Yes (Conditional)</p> <p><b>Note:</b> This data is required while defining or editing the respective information.</p>
If this tag is used within...	Then the purpose of the billRouteType tag is...							
accountData	Used to indicate how the account's bill must be sent to the main customer.							
accountPersonRouting	Used to indicate how the account's bill must be sent to the linked person.							
billAddressSource	<p>You can use this tag within the following tags:</p> <table border="1" data-bbox="602 806 1219 1577"> <thead> <tr> <th data-bbox="602 806 894 884">If this tag is used within...</th> <th data-bbox="894 806 1219 884">Then the purpose of the billAddressSource tag is...</th> </tr> </thead> <tbody> <tr> <td data-bbox="602 884 894 1230">accountData</td> <td data-bbox="894 884 1219 1230">Used to indicate whether the account's bill must be sent to the main customer's mailing address or to the main customer's account override address. The valid values are: <ul style="list-style-type: none"> <li>• PER</li> <li>• ACOV</li> </ul> </td> </tr> <tr> <td data-bbox="602 1230 894 1577">accountPersonRouting</td> <td data-bbox="894 1230 1219 1577">Used to indicate whether the account's bill must be sent to the linked person's mailing address or to the linked person's account override address. The valid values are: <ul style="list-style-type: none"> <li>• PER</li> <li>• ACOV</li> </ul> </td> </tr> </tbody> </table> <p><b>Note:</b> You must specify a value which is already defined in the <b>BILL_ADDR_SRCE_FLG</b> lookup field. It must be in the <b>Active</b> status.</p>	If this tag is used within...	Then the purpose of the billAddressSource tag is...	accountData	Used to indicate whether the account's bill must be sent to the main customer's mailing address or to the main customer's account override address. The valid values are: <ul style="list-style-type: none"> <li>• PER</li> <li>• ACOV</li> </ul>	accountPersonRouting	Used to indicate whether the account's bill must be sent to the linked person's mailing address or to the linked person's account override address. The valid values are: <ul style="list-style-type: none"> <li>• PER</li> <li>• ACOV</li> </ul>	<p>Yes (Conditional)</p> <p><b>Note:</b> This data is required while defining the respective information.</p>
If this tag is used within...	Then the purpose of the billAddressSource tag is...							
accountData	Used to indicate whether the account's bill must be sent to the main customer's mailing address or to the main customer's account override address. The valid values are: <ul style="list-style-type: none"> <li>• PER</li> <li>• ACOV</li> </ul>							
accountPersonRouting	Used to indicate whether the account's bill must be sent to the linked person's mailing address or to the linked person's account override address. The valid values are: <ul style="list-style-type: none"> <li>• PER</li> <li>• ACOV</li> </ul>							

Tag Name	Tag Description	Mandatory (Yes or No)
autoPayDetails	Used to specify the auto pay instruction for the account.	Yes (Conditional)  <b>Note:</b> This data is required while defining or editing an auto pay instruction of an account.
priority	Used to indicate the priority in which the auto pay instruction should be considered when multiple auto pay instructions are effective on the bill's due date.  <b>Note:</b> The priority cannot be less than or equal to zero.	Yes (Conditional)  <b>Note:</b> This data is required while defining or editing an auto pay instruction of an account.
percentage	Used to indicate the percentage in which the payment must be split between two or more auto pay sources having the same priority.	Yes (Conditional)  <b>Note:</b> This data is required while defining or editing the split auto pay instruction for an account.
autoPayMethod	Used to indicate how you want to process the automatic payment request. The valid values are: <ul style="list-style-type: none"> <li>• <b>C1DD</b> - Indicates that you want to directly debit the main customer's bank account.</li> <li>• <b>C1PA</b> - Indicates that you want to send a payment advice to the main customer.</li> </ul>	No
autoPayRouteType	Used to indicate when and how automatic payment request of the account is routed to a financial institution.  <b>Note:</b> You must specify an auto pay route type which is already defined in the system.	Yes (Conditional)  <b>Note:</b> This data is required while defining or editing an auto pay instruction of an account.
autoPaySourceCode	Used to indicate the financial institution that receives the automatic payment request.  <b>Note:</b> You must specify an auto pay source which is already defined in the system.	Yes (Conditional)  <b>Note:</b> This data is required while defining or editing an auto pay instruction of an account.

Tag Name	Tag Description	Mandatory (Yes or No)
accountNumber	Used to indicate the bank account number through which the automatic payment must be done.	Yes (Conditional)  <b>Note:</b> This data is required while defining or editing an auto pay instruction of an account.
expiryMonth	Used to specify the month when the tender type of the auto pay source will expire.  <b>Note:</b> You must specify the month in the MM format.	Yes (Conditional)  <b>Note:</b> This data is required when the <b>Expiration Date Required</b> option is selected for the tender type which is specified in the auto pay source.
expiryYear	Used to specify the year when the tender type of the auto pay source will expire.  <b>Note:</b> You must specify the year in the YYYY format.	Yes (Conditional)  <b>Note:</b> This data is required when the <b>Expiration Date Required</b> option is selected for the tender type which is specified in the auto pay source.
name	Used to specify the name of the person as it appears in the financial institution's system.	No
maxWithdrawalAmount	Used to specify the maximum amount that can be automatically debited from the bank account. It is used to set the limit on the withdrawal amount.  <b>Note:</b> The maximum withdrawal amount cannot be less than zero.	No

Tag Name	Tag Description	Mandatory (Yes or No)														
accountPerson	<p>Used to specify information about the person (other than main customer) to whom you want to link the account.</p> <p><b>Note:</b> The system, by default, adds the person (for whom the account information is given in the health care inbound message) as the main customer of the account. While linking the person as main customer of the account, the system sets the following attributes:</p> <table border="1" data-bbox="602 562 1227 940"> <thead> <tr> <th data-bbox="602 562 954 611">Attribute Name</th> <th data-bbox="954 562 1227 611">Attribute Value</th> </tr> </thead> <tbody> <tr> <td data-bbox="602 611 954 659">Financially Responsible</td> <td data-bbox="954 611 1227 659">Y</td> </tr> <tr> <td data-bbox="602 659 954 707">Account Relationship Type</td> <td data-bbox="954 659 1227 707">Main Customer</td> </tr> <tr> <td data-bbox="602 707 954 756">Receive Copy of Bill</td> <td data-bbox="954 707 1227 756">Y</td> </tr> <tr> <td data-bbox="602 756 954 804">Bill Format</td> <td data-bbox="954 756 1227 804">Detailed</td> </tr> <tr> <td data-bbox="602 804 954 852">Receives Notification</td> <td data-bbox="954 804 1227 852">Y</td> </tr> <tr> <td data-bbox="602 852 954 900">Number of Bill Copies</td> <td data-bbox="954 852 1227 900">1</td> </tr> </tbody> </table>	Attribute Name	Attribute Value	Financially Responsible	Y	Account Relationship Type	Main Customer	Receive Copy of Bill	Y	Bill Format	Detailed	Receives Notification	Y	Number of Bill Copies	1	<p>Yes (Conditional)</p> <p><b>Note:</b> This data is required while linking a person to an account.</p>
Attribute Name	Attribute Value															
Financially Responsible	Y															
Account Relationship Type	Main Customer															
Receive Copy of Bill	Y															
Bill Format	Detailed															
Receives Notification	Y															
Number of Bill Copies	1															
accountRelationshipType	<p>Used to indicate how the person is related to the account.</p> <p><b>Note:</b> You must specify an account relationship type which is already defined in the system.</p>	<p>Yes (Conditional)</p> <p><b>Note:</b> This data is required while linking a person to an account.</p>														
isFinanciallyResponsible	<p>Used to indicate whether the person is financially responsible for the account. The valid values are:</p> <ul style="list-style-type: none"> <li>• true</li> <li>• false</li> </ul> <p><b>Note:</b> If you do not specify the value, by default, it is set to <b>false</b>.</p>	<p>No</p>														
personAddressOverride	<p>Used to specify the account override address for the linked person.</p>	<p>No</p>														
postal	<p>Used to specify the postal code of the address.</p>	<p>No</p>														
accountPersonRouting	<p>Used to specify the bill routing information for the linked person.</p>	<p>Yes (Conditional)</p> <p><b>Note:</b> This data is required while defining or editing the bill routing information of a linked person.</p>														



Tag Name	Tag Description	Mandatory (Yes or No)
shouldReceiveCopyOfBill	<p>Used to indicate whether the linked person should receive a copy of the account's bill. The valid values are:</p> <ul style="list-style-type: none"> <li>• Y</li> <li>• N</li> </ul> <p><b>Note:</b> If you do not specify the value, by default, it is set to <b>N</b>.</p>	No
billFormat	<p>Used to indicate whether the linked person should receive the detailed or summary bill. The valid values are:</p> <ul style="list-style-type: none"> <li>• D</li> <li>• S</li> </ul> <p><b>Note:</b> You must specify a value which is already defined in the <b>BILL_FORMAT_FLG</b> lookup field. It must be in the <b>Active</b> status. If you do not specify the value, by default, it is set to <b>D</b> when the linked person should receive a copy of the account's bill. This information is ignored when the <b>shouldReceiveCopyOfBill</b> tag contains <b>N</b>.</p>	No
numberOfBillCopies	<p>Used to indicate the number of copies of the bill which the linked person must receive.</p> <p><b>Note:</b> If you do not specify the value, by default, it is set to <b>1</b> when the linked person should receive a copy of the account's bill. This information is ignored when the <b>shouldReceiveCopyOfBill</b> tag contains <b>N</b>.</p>	No
receivesNotification	<p>Used to indicate whether the linked person should receive letters (i.e. notifications) initiated by collection, write-off, and overdue events. The valid values are:</p> <ul style="list-style-type: none"> <li>• Y</li> <li>• N</li> </ul> <p><b>Note:</b> If you do not specify the value, by default, it is set to <b>N</b>. This information is ignored when the <b>shouldReceiveCopyOfBill</b> tag contains <b>N</b>.</p>	No

Tag Name	Tag Description	Mandatory (Yes or No)
policyData	Used to specify the details of the policy.	Yes (Conditional)  <b>Note:</b> This data is required while defining or editing a policy.
policyType	Used to indicate the type of policy.  <b>Note:</b> You must specify a policy type which is already defined in the system. If you want to create a fully-insured group policy, you must specify a policy type where the policy category is set to <b>Fully-Insured Group</b> . However, if you want to create a self-funded policy, you must specify a policy type where the policy category is set to <b>Self-Funded</b> .	Yes (Conditional)  <b>Note:</b> This data is required while defining a policy.
runOutEndDate	Used to specify the date when the runout period of the self-funded policy ends.  <b>Note:</b> The runout end date cannot be earlier than the policy end date. You must specify the date in the YYYY-MM-DD format.	No
runOutAdminOption	Used to indicate whether the administration fees must be charged when the claim transaction for the self-funded policy is processed in the runout period. The valid values are: <ul style="list-style-type: none"><li>• NROA</li><li>• PERC</li></ul> <b>Note:</b> At present, this data is used only for the informational purpose and is not considered during the billable charge creation for the claim transactions which are received in the runout period of the policy. You must specify a value which is already defined in the <b>RUNOUT_ADM_OPT_FLG</b> lookup field. It must be in the <b>Active</b> status.	No
renewalDate	Used to specify the date when you want to renew the fully-insured group policy.  <b>Note:</b> You can renew a self-funded policy only from the user interface. You must specify the date in the YYYY-MM-DD format.	Yes (Conditional)  <b>Note:</b> This data is required while renewing a fully-insured group policy.

Tag Name	Tag Description	Mandatory (Yes or No)
policyPersons	Used to associate a person with the policy.	Yes (Conditional) <b>Note:</b> This data is required while associating a person with the policy.
policyPerRole	Used to indicate the role of the person in the policy. <b>Note:</b> You must specify a policy person role which is already defined in the system.	Yes (Conditional) <b>Note:</b> This data is required while associating a person with the policy.
terminationInformation	Used to specify the termination details of the fully-insured group policy. <b>Note:</b> At present, you cannot terminate a self-funded policy either from the user interface or through a health care inbound message.	No
terminateDate	Used to specify the date when you want to terminate the fully-insured group policy. <b>Note:</b> You must specify the date in the YYYY-MM-DD format. The termination date cannot be earlier than the policy start date. On terminating a policy, the status of the policy is changed to the status which is specified in the <b>Policy Termination Status</b> option type of the <b>C1-ASOBLLNG</b> feature configuration.	Yes (Conditional) <b>Note:</b> This data is required while terminating a fully-insured group policy.
terminationReason	Used to indicate the reason why you want to terminate the fully-insured group policy. <b>Note:</b> You must specify the status reason which is already defined for the status specified in the <b>Policy Termination Status</b> option type of the <b>C1-ASOBLLNG</b> feature configuration.	Yes (Conditional) <b>Note:</b> This data is required while terminating a fully-insured group policy.
reinstateInformation	Used to specify the reinstatement details of the fully-insured group policy. <b>Note:</b> At present, you cannot reinstate a self-funded policy either from the user interface or through a health care inbound message.	No

Tag Name	Tag Description	Mandatory (Yes or No)
reinstatementDate	<p>Used to specify the date when you want to reinstate the fully-insured group policy.</p> <p><b>Note:</b> You must specify the date in the YYYY-MM-DD format. The reinstatement date cannot be earlier than the policy start date. On reinstating a policy, the status of the policy is changed to the status which is specified in the <b>Policy Reinstatement Status</b> option type of the <b>C1-ASOBLNG</b> feature configuration.</p>	<p>Yes (Conditional)</p> <p><b>Note:</b> This data is required while reinstating a fully-insured group policy.</p>
reinstatementReason	<p>Used to indicate the reason why you want to reinstate the fully-insured group policy.</p> <p><b>Note:</b> You must specify the status reason which is already defined for the status specified in the <b>Policy Reinstatement Status</b> option type of the <b>C1-ASOBLNG</b> feature configuration.</p>	<p>Yes (Conditional)</p> <p><b>Note:</b> This data is required while reinstating a fully-insured group policy.</p>
planData	<p>Used to specify the details of the policy plan.</p> <p><b>Note:</b> At present, you can only define a policy plan in a fully-insured group policy. Therefore, the system will ignore this information when given for a self-funded policy.</p>	<p>Yes (Conditional)</p> <p><b>Note:</b> This data is required while defining or editing a policy plan.</p>
planName	Used to specify the description for the policy plan.	No
pricingRuleTypeList	Used to associate a pricing rule type with the policy plan.	<p>Yes (Conditional)</p> <p><b>Note:</b> This data is required while associating a pricing rule type with the policy plan.</p>
pricingRuleType	<p>Used to specify the pricing rule type.</p> <p><b>Note:</b> At present, you can only associate those pricing rule types where the category is set to <b>Age Based, Tier Based, or Pass-Through Billable Charge</b>. Therefore, the system will ignore the pricing rule types where the category is set to <b>Claim, Specific Stop-Loss, Aggregate Stop-Loss, Retention Type Claim Based, Retention Type Enrollment Based, Flat Fees, Ancillary, Discount Arrangement, or Level Funded</b>.</p>	<p>Yes (Conditional)</p> <p><b>Note:</b> This data is required when a price item is not associated with the policy plan.</p>

Tag Name	Tag Description	Mandatory (Yes or No)
primaryPlanSw	Used to indicate whether the plan is a primary plan in the policy. The valid values are: <ul style="list-style-type: none"> <li>• Y</li> <li>• N</li> </ul> <div style="border: 1px solid black; padding: 2px; margin-top: 5px;"> <b>Note:</b> If you do not specify the value, by default, it is set to N.           </div>	No
pricingRuleData	Used to specify the details of the pricing rule.	Yes (Conditional) <div style="border: 1px solid black; padding: 2px; margin-top: 5px;"> <b>Note:</b> This data is required while defining or editing a pricing rule.           </div>
entityType	Used to indicate the type of entity for which you want to define the pricing rule. The valid value is: <ul style="list-style-type: none"> <li>• PLAN</li> </ul>	Yes (Conditional) <div style="border: 1px solid black; padding: 2px; margin-top: 5px;"> <b>Note:</b> This data is required while defining or editing a pricing rule.           </div>
entityIdentifier	Used to indicate the policy plan for which you want to define the pricing rule.	Yes (Conditional) <div style="border: 1px solid black; padding: 2px; margin-top: 5px;"> <b>Note:</b> This data is required while defining or editing a pricing rule.           </div>
pricingRuleType	Used to indicate the pricing rule type using which you want to define the pricing rule. <div style="border: 1px solid black; padding: 2px; margin-top: 5px;"> <b>Note:</b> You must specify a pricing rule type where the category is set to <b>Age Based</b> or <b>Tier Based</b>.           </div>	Yes (Conditional) <div style="border: 1px solid black; padding: 2px; margin-top: 5px;"> <b>Note:</b> This data is required while defining or editing a pricing rule.           </div>
priceItemCd	Used to indicate the price item for which you want to define the pricing rule. <div style="border: 1px solid black; padding: 2px; margin-top: 5px;"> <b>Note:</b> You must specify a price item which is already associated with the respective pricing rule type.           </div>	Yes (Conditional) <div style="border: 1px solid black; padding: 2px; margin-top: 5px;"> <b>Note:</b> This data is required while defining or editing a pricing rule.           </div>

Tag Name	Tag Description	Mandatory (Yes or No)
rateOption	<p>Used to indicate the rate option using which you want to create price assignment for the pricing rule.</p> <div style="border: 1px solid black; padding: 5px;"> <p><b>Note:</b></p> <p>You must specify a rate option which is already defined in the <b>C1-ExtLookRetTypeRateOpt</b> extendable lookup. It must be in the <b>Active</b> status.</p> <p>If the rate option is not given for an age-based pricing rule, by default, it is set to:</p> <ul style="list-style-type: none"> <li>The value specified in the <b>Default Rate Option – Flat</b> option type of the <b>C1-ASOBLNG</b> feature configuration when the modifier method is set to <b>FLAT</b></li> <li>The value specified in the <b>Default Rate Option – Percentage</b> option type of the <b>C1-ASOBLNG</b> feature configuration when the modifier method is set to <b>EXPT</b> or <b>INPT</b></li> </ul> <p>However, if the rate option is not given for a tier-based pricing rule, by default, it is set to a value specified in the <b>Default Rate Option – Flat</b> option type of the <b>C1-ASOBLNG</b> feature configuration when the modifier method is set to <b>FLAT</b> or <b>NULL</b>.</p> </div>	No
modifierApplicability	<p>Used to indicate whether you want to increase or decrease the premium of an eligible member based on certain modifiers (i.e. parameters, such as tobacco usage, alcohol usage, and so on). The valid values are:</p> <ul style="list-style-type: none"> <li>Y</li> <li>N</li> </ul> <div style="border: 1px solid black; padding: 5px;"> <p><b>Note:</b> If you do not specify the value, by default, it is set to <b>N</b>.</p> </div>	No
modifierMethod	<p>Used to indicate whether the system should consider the modifier rate as a flat amount or percentage. The valid values are:</p> <ul style="list-style-type: none"> <li><b>FLAT</b> - Indicates that the system should consider the modifier rate as a flat amount.</li> <li><b>INPT</b> - Indicates that the system should consider the modifier rate as inclusive percentage.</li> <li><b>EXPT</b> - Indicates that the system should consider the modifier rate as exclusive percentage.</li> </ul>	<p>Yes (Conditional)</p> <div style="border: 1px solid black; padding: 5px;"> <p><b>Note:</b> This data is required when the <b>modifierApplicability</b> tag contains <b>Y</b>.</p> </div>

Tag Name	Tag Description	Mandatory (Yes or No)
baseRate	<p>Used to specify the base fees for employees with a particular set of attributes. You can define different base fees for employees with different set of attributes.</p> <p><b>Note:</b> While creating a price assignment for the pricing rule, the system creates one price component for each given set of base rate information.</p>	<p>Yes (Conditional)</p> <p><b>Note:</b> This data is required while defining a pricing rule.</p>
baseFee	<p>Used to specify the base fees for the eligible members.</p>	<p>Yes (Conditional)</p> <p><b>Note:</b> This data is required while defining a pricing rule.</p>
lowerAgeLimit	<p>Used to specify the lower age limit. It is used to define lower age limit pricing eligibility criteria in the price component.</p> <p><b>Note:</b> The system defines the lower age limit pricing eligibility criteria using the parameter which is specified in the <b>Age Based Parameter</b> option type of the <b>C1-ASOBLNG</b> feature configuration. This data is ignored when given in a tier-based pricing rule information.</p>	<p>Yes (Conditional)</p> <p><b>Note:</b> This data is required while defining an age-based pricing rule.</p>
upperAgeLimit	<p>Used to specify the upper age limit. It is used to define upper age limit pricing eligibility criteria in the price component.</p> <p><b>Note:</b> The system defines the upper age limit pricing eligibility criteria using the parameter which is specified in the <b>Age Based Parameter</b> option type of the <b>C1-ASOBLNG</b> feature configuration. This data is ignored when given in a tier-based pricing rule information.</p>	<p>Yes (Conditional)</p> <p><b>Note:</b> This data is required while defining an age-based pricing rule.</p>
pricingParameter	<p>Used to specify a set of employee attributes based on which the base fees may vary.</p>	<p>Yes (Conditional)</p> <p><b>Note:</b> This data is required while defining a tier-based pricing rule.</p>

Tag Name	Tag Description	Mandatory (Yes or No)						
parameterCode	<p>You can use this tag within the following tags:</p> <table border="1" data-bbox="602 300 1227 772"> <thead> <tr> <th data-bbox="602 300 857 384">If this tag is used within...</th> <th data-bbox="857 300 1227 384">Then the purpose of the parameterCode tag is...</th> </tr> </thead> <tbody> <tr> <td data-bbox="602 384 857 594">pricingParameter</td> <td data-bbox="857 384 1227 594">Used to specify the employee attribute (i.e. parameter, such as employee status, employee location, and so on) using which you want to define the pricing eligibility criteria.</td> </tr> <tr> <td data-bbox="602 594 857 772">modifierInformation</td> <td data-bbox="857 594 1227 772">Used to specify the modifier (i.e. parameter, such as tobacco usage, alcohol usage, and so on) using which you want to define the pricing eligibility criteria.</td> </tr> </tbody> </table> <p><b>Note:</b> You must define the employee attributes and modifiers as parameters in the system. Note that you must set the parameter usage for these parameters to <b>Pricing Eligibility Criteria</b>. The system creates an pricing eligibility criteria for each parameter and/or modifier specified in the pricing rule information. You cannot specify any special character except underscore (_) in the parameter name.</p>	If this tag is used within...	Then the purpose of the parameterCode tag is...	pricingParameter	Used to specify the employee attribute (i.e. parameter, such as employee status, employee location, and so on) using which you want to define the pricing eligibility criteria.	modifierInformation	Used to specify the modifier (i.e. parameter, such as tobacco usage, alcohol usage, and so on) using which you want to define the pricing eligibility criteria.	<p>Yes (Conditional)</p> <p><b>Note:</b> This data is required while specifying the respective information.</p>
If this tag is used within...	Then the purpose of the parameterCode tag is...							
pricingParameter	Used to specify the employee attribute (i.e. parameter, such as employee status, employee location, and so on) using which you want to define the pricing eligibility criteria.							
modifierInformation	Used to specify the modifier (i.e. parameter, such as tobacco usage, alcohol usage, and so on) using which you want to define the pricing eligibility criteria.							
parameterValue	<p>You can use this tag within the following tags:</p> <table border="1" data-bbox="602 1234 1227 1518"> <thead> <tr> <th data-bbox="602 1234 857 1318">If this tag is used within...</th> <th data-bbox="857 1234 1227 1318">Then the purpose of the parameterValue tag is...</th> </tr> </thead> <tbody> <tr> <td data-bbox="602 1318 857 1434">pricingParameter</td> <td data-bbox="857 1318 1227 1434">Used to specify the value for the parameter (i.e. employee attribute).</td> </tr> <tr> <td data-bbox="602 1434 857 1518">modifierInformation</td> <td data-bbox="857 1434 1227 1518">Used to specify the value for the parameter (i.e. modifier).</td> </tr> </tbody> </table> <p><b>Note:</b> You can specify any special characters except ampersand (&amp;), comma (,), underscore (_), equal to (=), tilde (~), and semi-colon(;) in the parameter value.</p>	If this tag is used within...	Then the purpose of the parameterValue tag is...	pricingParameter	Used to specify the value for the parameter (i.e. employee attribute).	modifierInformation	Used to specify the value for the parameter (i.e. modifier).	<p>Yes (Conditional)</p> <p><b>Note:</b> This data is required while specifying the respective information.</p>
If this tag is used within...	Then the purpose of the parameterValue tag is...							
pricingParameter	Used to specify the value for the parameter (i.e. employee attribute).							
modifierInformation	Used to specify the value for the parameter (i.e. modifier).							



Tag Name	Tag Description	Mandatory (Yes or No)
modifierInformation	Used to specify the modifier based on which you want to increase or decrease the base fees.  <b>Note:</b> While creating a price assignment for the pricing rule, the system creates one price component for each given set of modifier information and then links these modifier price components with the respective base rate price component.	Yes (Conditional)  <b>Note:</b> This data is required while specifying the modifier information.
rate	Used to specify the flat amount or percentage by which you want to increase or decrease the premium of an eligible member.	Yes (Conditional)  <b>Note:</b> This data is required while specifying the modifier information.

The following table lists and describes the tags which are available in the health care inbound message schema, but should not be included in the XML file:

Tag Name	Tag Description						
c1InboundMessage	Displays the inbound message ID.						
boStatus	Displays the status of the health care inbound message.						
statusReason	Indicates the reason why the status of the health care inbound message is changed.						
person	At present, this tag is not supported in a health care inbound message.						
statusDateTime	Displays the date and time when the status of the health care inbound message is changed in the system.						
creationDateTime	Displays the date and time when the health care inbound message is created in the system.						
searchCharacteristicValue	At present, this tag is not supported in a health care inbound message.						
version	This tag appears within the following parent tags: <table border="1" data-bbox="683 1446 1463 1728"> <thead> <tr> <th>Parent Tag</th> <th>Then the purpose of the version tag is...</th> </tr> </thead> <tbody> <tr> <td>schema</td> <td>Displays the version of the health care inbound message.</td> </tr> <tr> <td>inboundMessageCharacteristic</td> <td>Displays the version of the characteristic defined for the health care inbound message.</td> </tr> </tbody> </table>	Parent Tag	Then the purpose of the version tag is...	schema	Displays the version of the health care inbound message.	inboundMessageCharacteristic	Displays the version of the characteristic defined for the health care inbound message.
Parent Tag	Then the purpose of the version tag is...						
schema	Displays the version of the health care inbound message.						
inboundMessageCharacteristic	Displays the version of the characteristic defined for the health care inbound message.						
paidThroughDate	Indicates the term end date of the last fully or partially paid term. For more information about the paid through date, refer to <a href="#">Policy</a> on page 2095.						

Tag Name	Tag Description
toDoRetry	Displays the information about the retry option used for the health care inbound message.  <b>Note:</b> This information appears at the bottom of the inbound message in the <b>Inbound Message Content</b> zone once the health care inbound message is validated and processed either through the user interface or batch process.
retryDateTime	Displays the date and time when the retry option is used to change the status of the health care inbound message from <b>Rejected</b> to <b>Pending</b> .
numberOfRetries	Indicates the number of times the retry option is used for the health care inbound message.
currentErrorState	Indicates the status to which the health care inbound message is transitioned when its validation or processing fails. The valid value is: <ul style="list-style-type: none"> <li>REJECTED</li> </ul>
isRetried	Indicates whether the retry option is used to change the status of the health care inbound message. The valid values are: <ul style="list-style-type: none"> <li>true</li> <li>false</li> </ul>

### Related Topics

For more information on...	See...
Health Care Inbound Message Schema	<a href="#">Health Care Inbound Message Schema</a> on page 1914
Sample Health Care Inbound Message for Fully-Insured Customer Setup	<a href="#">Sample Health Care Inbound Message for Fully-Insured Customer Setup</a> on page 1920
Sample Health Care Inbound Message for Membership	<a href="#">Sample Health Care Inbound Message for Membership</a> on page 1968
Sample Health Care Inbound Message for Pricing Rules	<a href="#">Sample Health Care Inbound Message for Pricing Rules</a> on page 1960
Sample Health Care Inbound Message for Self-Funded Customer Setup	<a href="#">Sample Health Care Inbound Message for Self-Funded Customer Setup</a> on page 1945
How to setup the C1-ASOBLNG feature configuration	<a href="#">Setting the C1-ASOBLNG Feature Configuration</a> on page 2889

## Health Care Inbound Message Schema

```
<schema>
  <clInboundMessage></clInboundMessage>
  <bo></bo>
  <boStatus></boStatus>
  <statusReason></statusReason>
  <messageType></messageType>
  <sourceSystem></sourceSystem>
  <externalTransactionId></externalTransactionId>
  <externalBatchId></externalBatchId>
  <externalSourceId></externalSourceId>
  <person></person>
```

```

<statusDateTime></statusDateTime>
<creationDateTime></creationDateTime>
<version></version>
<characteristics>
  <inboundMessageCharacteristic>
    <adhocCharacteristicValue></adhocCharacteristicValue>
    <characteristicType></characteristicType>
    <effectiveDate></effectiveDate>
    <characteristicValue></characteristicValue>
    <characteristicValueForeignKey1></characteristicValueForeignKey1>
    <characteristicValueFK2></characteristicValueFK2>
    <characteristicValueFK3></characteristicValueFK3>
    <characteristicValueFK4></characteristicValueFK4>
    <characteristicValueFK5></characteristicValueFK5>
    <searchCharacteristicValue></searchCharacteristicValue>
    <version></version>
  </inboundMessageCharacteristic>
</characteristics>
<customerStructureMessage>
  <headerData>
    <messageType></messageType>
    <sourceSystem></sourceSystem>
    <externalTransactionId></externalTransactionId>
    <externalBatchId></externalBatchId>
    <externalSourceId></externalSourceId>
  </headerData>
  <customerStructureData>
    <personData>
      <sequence></sequence>
      <personType></personType>
      <personName>
        <sequence></sequence>
        <entityName></entityName>
        <nameType></nameType>
      </personName>
      <identifiers>
        <idType></idType>
        <idValue></idValue>
        <isPrimary></isPrimary>
      </identifiers>
      <division></division>
      <birthDate></birthDate>
      <sinceDate></sinceDate>
      <address>
        <addressEffDate></addressEffDate>
        <addressType></addressType>
        <mailingName></mailingName>
        <address1></address1>
        <address2></address2>
        <address3></address3>
        <address4></address4>
        <city></city>
        <state></state>
        <zip></zip>
        <country></country>
      </address>
      <email></email>
      <overrideMailingName1></overrideMailingName1>
      <overrideMailingName2></overrideMailingName2>
      <overrideMailingName3></overrideMailingName3>
      <phones>
        <phoneType></phoneType>
        <phoneValue></phoneValue>
      </phones>
    </personData>
  </customerStructureData>
</customerStructureMessage>

```

```

<relatedPersons>
  <idType></idType>
  <idValue></idValue>
  <personRelationshipType></personRelationshipType>
  <startDate></startDate>
  <endDate></endDate>
  <financialRelationshipSw></financialRelationshipSw>
  <parentOrChild></parentOrChild>
  <characteristics>
    <characteristicsList>
      <characteristicType></characteristicType>
      <characteristicValue></characteristicValue>
      <effectiveDate></effectiveDate>
    </characteristicsList>
  </characteristics>
</relatedPersons>
<characteristics>
  <characteristicsList>
    <characteristicType></characteristicType>
    <characteristicValue></characteristicValue>
    <effectiveDate></effectiveDate>
  </characteristicsList>
</characteristics>
<billLevelParameters>
  <sequence></sequence>
  <sourceSystem></sourceSystem>
  <billLevelInfo1></billLevelInfo1>
  <billLevelInfo2></billLevelInfo2>
  <billLevelInfo3></billLevelInfo3>
  <billLevelInfo4></billLevelInfo4>
  <effectiveDate></effectiveDate>
</billLevelParameters>
<memberData>
  <startDate></startDate>
  <endDate></endDate>
  <paidThroughDate></paidThroughDate>
  <memberId></memberId>
  <memberRelationship></memberRelationship>
  <mainSubscriber>
    <idType></idType>
    <idValue></idValue>
  </mainSubscriber>
  <policyNumber></policyNumber>
  <sourceSystem></sourceSystem>
  <planNumber></planNumber>
  <characteristics>
    <characteristicsList>
      <characteristicType></characteristicType>
      <characteristicValue></characteristicValue>
      <effectiveDate></effectiveDate>
    </characteristicsList>
  </characteristics>
  <membershipPersonCharacteristic>
    <characteristicsList>
      <characteristicType></characteristicType>
      <characteristicValue></characteristicValue>
      <effectiveDate></effectiveDate>
    </characteristicsList>
  </membershipPersonCharacteristic>
  <billableChargeData>
    <sequence></sequence>
    <accountIdType></accountIdType>
    <accountIdValue></accountIdValue>
    <chargeType></chargeType>

```

```

    <startDate></startDate>
    <endDate></endDate>
    <priceItemCode></priceItemCode>
    <description></description>
    <recurringMethod></recurringMethod>
    <billPeriod></billPeriod>
    <frequency></frequency>
    <billAfterDt></billAfterDt>
    <billableChargeLines>
      <descriptionOnBill></descriptionOnBill>
      <currencyCode></currencyCode>
      <chargeAmount></chargeAmount>
      <showOnBillSw></showOnBillSw>
      <appearInSummarySw></appearInSummarySw>
      <distributionCode></distributionCode>
    </billableChargeLines>
    <characteristics>
      <characteristicsList>
        <characteristicType></characteristicType>
        <characteristicValue></characteristicValue>
        <effectiveDate></effectiveDate>
      </characteristicsList>
    </characteristics>
  </billableChargeData>
</memberData>
<accountData>
  <accountType></accountType>
  <customerClass></customerClass>
  <billCycle></billCycle>
  <billLeadDays></billLeadDays>
  <division></division>
  <currency></currency>
  <setUpDate></setUpDate>
  <acctUsageFlg></acctUsageFlg>
  <comments></comments>
  <deferAutoPayDt></deferAutoPayDt>
  <collectionClass></collectionClass>
  <billRouteType></billRouteType>
  <billAddressSource></billAddressSource>
  <identifiers>
    <idType></idType>
    <idValue></idValue>
    <isPrimary></isPrimary>
  </identifiers>
  <address>
    <addressEffDate></addressEffDate>
    <addressType></addressType>
    <address1></address1>
    <address2></address2>
    <address3></address3>
    <address4></address4>
    <city></city>
    <state></state>
    <zip></zip>
    <country></country>
  </address>
  <autoPayDetails>
    <priority></priority>
    <startDate></startDate>
    <endDate></endDate>
    <percentage></percentage>
    <autoPayMethod></autoPayMethod>
    <autoPayRouteType></autoPayRouteType>
    <autoPaySourceCode></autoPaySourceCode>
  </autoPayDetails>
</accountData>

```

```

        <accountNumber></accountNumber>
        <expiryMonth></expiryMonth>
        <expiryYear></expiryYear>
        <name></name>
        <maxWithdrawalAmount></maxWithdrawalAmount>
        <comments></comments>
    </autoPayDetails>
    <accountPerson>
        <idType></idType>
        <idValue></idValue>
        <accountRelationshipType></accountRelationshipType>
        <isFinanciallyResponsible></isFinanciallyResponsible>
        <personAddressOverride>
            <address1></address1>
            <address2></address2>
            <address3></address3>
            <address4></address4>
            <city></city>
            <postal></postal>
            <state></state>
            <country></country>
        </personAddressOverride>
        <accountPersonRouting>
            <billRouteType></billRouteType>
            <shouldReceiveCopyOfBill></
shouldReceiveCopyOfBill>
            <billFormat></billFormat>
            <numberOfBillCopies></numberOfBillCopies>
            <receivesNotification></receivesNotification>
            <billAddressSource></billAddressSource>
        </accountPersonRouting>
    </accountPerson>
    <characteristics>
        <characteristicsList>
            <characteristicType></characteristicType>
            <characteristicValue></characteristicValue>
            <effectiveDate></effectiveDate>
        </characteristicsList>
    </characteristics>
</accountData>
<policyData>
    <policyType></policyType>
    <sourceSystem></sourceSystem>
    <policyNumber></policyNumber>
    <description></description>
    <startDate></startDate>
    <endDate></endDate>
    <runOutEndDate></runOutEndDate>
    <runOutAdminOption></runOutAdminOption>
    <renewalDate></renewalDate>
    <policyPersons>
        <idType></idType>
        <idValue></idValue>
        <policyPerRole></policyPerRole>
        <startDate></startDate>
        <endDate></endDate>
    </policyPersons>
    <terminationInformation>
        <terminateDate></terminateDate>
        <terminationReason></terminationReason>
    </terminationInformation>
    <reinstateInformation>
        <reinstatementDate></reinstatementDate>
        <reinstateReason></reinstateReason>

```

```

    </reinstateInformation>
    <characteristics>
      <characteristicsList>
        <characteristicType></characteristicType>
        <characteristicValue></characteristicValue>
        <effectiveDate></effectiveDate>
      </characteristicsList>
    </characteristics>
    <planData>
      <planNumber></planNumber>
      <priceItemCode></priceItemCode>
      <planName></planName>
      <pricingRuleTypeList>
        <pricingRuleType></pricingRuleType>
      </pricingRuleTypeList>
      <startDate></startDate>
      <endDate></endDate>
      <primaryPlanSw></primaryPlanSw>
      <characteristics>
        <characteristicsList>
          <characteristicType></characteristicType>
          <characteristicValue></characteristicValue>
          <effectiveDate></effectiveDate>
        </characteristicsList>
      </characteristics>
    </planData>
  </policyData>
</personData>
<pricingRuleData>
  <entityType></entityType>
  <entityIdentifier></entityIdentifier>
  <startDate></startDate>
  <endDate></endDate>
  <pricingRuleType></pricingRuleType>
  <priceItemCd></priceItemCd>
  <rateOption></rateOption>
  <modifierApplicability></modifierApplicability>
  <modifierMethod></modifierMethod>
  <baseRate>
    <sequence></sequence>
    <baseFee></baseFee>
    <lowerAgeLimit></lowerAgeLimit>
    <upperAgeLimit></upperAgeLimit>
    <pricingParameter>
      <sequence></sequence>
      <parameterCode></parameterCode>
      <parameterValue></parameterValue>
    </pricingParameter>
    <modifierInformation>
      <sequence></sequence>
      <parameterCode></parameterCode>
      <parameterValue></parameterValue>
      <rate></rate>
    </modifierInformation>
  </baseRate>
</pricingRuleData>
</customerStructureData>
</customerStructureMessage>
<toDoRetry>
  <retryDateTime>
  <numberOfRetries>
  <currentErrorState>
  <isRetried>
</toDoRetry>

```

&lt;/schema&gt;

## Sample Health Care Inbound Message for Fully-Insured Customer Setup

Using the below example, you can do the following:

- Create the parent customer and bill groups for a fully-insured health care business
- Create policies where the policy category is set to **Fully-Insured Group**
- Create various medical and dental plans for active and retired employees in the fully-insured group policies
- Associate a pricing rule type with the policy plans

Person Name	Person Type	Account	Policy	Policy Plan	Pricing Rule Type
Antartica Petroleum Corp	Parent Customer	-	Active Employee Medical Health Care Policy	HMO Medical Bronze 60 AE	AGE_BASED
				HMO Medical Silver 70 AE	AGE_BASED
				HMO Medical Gold 80 AE	AGE_BASED
				HMO Medical Platinum 90 AE	AGE_BASED
				PPO Medical Bronze 60 AE	AGE_BASED
				PPO Medical Silver 70 AE	AGE_BASED
				PPO Medical Gold 80 AE	AGE_BASED
				PPO Medical Platinum 90 AE	AGE_BASED
			Active Employee Dental Health Care Policy	DD BASIC PLAN AE	TIER_BASED
				DD STANDARD PLAN AE	TIER_BASED
			Retiree Employee Health Care Policy	HMO Medical Bronze 60 RE	AGE_BASED



Person Name	Person Type	Account	Policy	Policy Plan	Pricing Rule Type
				HMO Medical Silver 70 RE	AGE_BASED
				PPO Medical Bronze 60 RE	AGE_BASED
				PPO Medical Silver 70 RE	AGE_BASED
				DD BASIC RE	TIER_BASED
Antartica Petroleum ACTIVE	Bill Group	CMS	-	-	-
		CMR			
Antartica Petroleum COBRA	Bill Group	CMS	-	-	-
		CMR			
Antartica Petroleum RETIREE	Bill Group	CMS	Employee Medicare Policy	APE Medicare Bronze RE MALE	AGE_BASED
		CMR		APE Medicare Silver RE MALE	AGE_BASED
				APE Medicare Gold RE MALE	AGE_BASED
				APE Medicare Bronze RE FEMALE	AGE_BASED
				APE Medicare Silver RE FEMALE	AGE_BASED
				APE Medicare Gold RE FEMALE	AGE_BASED

In addition, using the below example, you can create the following derivation and pricing parameters for the above three bill groups:

Bill Group	Source System	Parameter 1	Parameter 2	Parameter 3	Parameter 4
Antartica Petroleum ACTIVE	SMALLPRIME	ACTIVE	SEATTLE	MEDICAL	HMO
	SMALLPRIME	ACTIVE	SEATTLE	MEDICAL	PPO
	SMALLPRIME	ACTIVE	SEATTLE	DENTAL	HMO
	SMALLPRIME	ACTIVE	SEATTLE	DENTAL	PPO
	SMALLPRIME	ACTIVE	SAN FRANCISCO	MEDICAL	HMO
	SMALLPRIME	ACTIVE	SAN FRANCISCO	MEDICAL	PPO
	SMALLPRIME	ACTIVE	SAN FRANCISCO	DENTAL	HMO
	SMALLPRIME	ACTIVE	SAN FRANCISCO	DENTAL	PPO
	SMALLPRIME	ACTIVE	LOS ANGELES	MEDICAL	HMO
	SMALLPRIME	ACTIVE	LOS ANGELES	MEDICAL	PPO
	SMALLPRIME	ACTIVE	LOS ANGELES	DENTAL	HMO
	SMALLPRIME	ACTIVE	LOS ANGELES	DENTAL	PPO
Antartica Petroleum COBRA	SMALLPRIME	COBRA	SEATTLE	MEDICAL	HMO
	SMALLPRIME	COBRA	SEATTLE	MEDICAL	PPO
	SMALLPRIME	COBRA	SEATTLE	DENTAL	HMO
	SMALLPRIME	COBRA	SEATTLE	DENTAL	PPO
	SMALLPRIME	COBRA	SAN FRANCISCO	MEDICAL	HMO
	SMALLPRIME	COBRA	SAN FRANCISCO	MEDICAL	PPO
	SMALLPRIME	COBRA	SAN FRANCISCO	DENTAL	HMO
	SMALLPRIME	COBRA	SAN FRANCISCO	DENTAL	PPO
	SMALLPRIME	COBRA	LOS ANGELES	MEDICAL	HMO

Bill Group	Source System	Parameter 1	Parameter 2	Parameter 3	Parameter 4
	SMALLPRIME	COBRA	LOS ANGELES	MEDICAL	PPO
	SMALLPRIME	COBRA	LOS ANGELES	DENTAL	HMO
	SMALLPRIME	COBRA	LOS ANGELES	DENTAL	PPO
Antartica Petroleum RETIREE	SMALLPRIME	RETIRED	SEATTLE	MEDICAL	HMO
	SMALLPRIME	RETIRED	SEATTLE	MEDICAL	PPO
	SMALLPRIME	RETIRED	SEATTLE	DENTAL	HMO
	SMALLPRIME	RETIRED	SEATTLE	DENTAL	PPO
	SMALLPRIME	RETIRED	SAN FRANCISCO	MEDICAL	HMO
	SMALLPRIME	RETIRED	SAN FRANCISCO	MEDICAL	PPO
	SMALLPRIME	RETIRED	SAN FRANCISCO	DENTAL	HMO
	SMALLPRIME	RETIRED	SAN FRANCISCO	DENTAL	PPO
	SMALLPRIME	RETIRED	LOS ANGELES	MEDICAL	HMO
	SMALLPRIME	RETIRED	LOS ANGELES	MEDICAL	PPO
	SMALLPRIME	RETIRED	LOS ANGELES	DENTAL	HMO
	SMALLPRIME	RETIRED	LOS ANGELES	DENTAL	PPO

```

<schema>
  <bo>C1-HCInboundMessage</bo>
  <characteristics>
    <inboundMessageCharacteristic>
      <ad hocCharacteristicValue></ad hocCharacteristicValue>
      <characteristicType>C1-EXTBTCT</characteristicType>
      <effectiveDate>2019-01-01</effectiveDate>
      <characteristicValue>DATAEXT1</characteristicValue>
      <characteristicValueForeignKey1></characteristicValueForeignKey1>
      <characteristicValueFK2></characteristicValueFK2>
      <characteristicValueFK3></characteristicValueFK3>
      <characteristicValueFK4></characteristicValueFK4>
      <characteristicValueFK5></characteristicValueFK5>
    </inboundMessageCharacteristic>
  </characteristics>

```

```

<customerStructureMessage>
  <headerData>
    <messageType>C1-HEALTHCARE-INB-MSG-TYPE</messageType>
    <sourceSystem>SMALLPRIME</sourceSystem>
    <externalTransactionId>889977</externalTransactionId>
    <externalBatchId>565656</externalBatchId>
    <externalSourceId>656565</externalSourceId>
  </headerData>
  <customerStructureData>
    <personData>
      <sequence>1</sequence>
      <personType>PG</personType>
      <personName>
        <sequence>1</sequence>
        <entityName>Antartica Petroleum Corp</entityName>
        <nameType>PRIM</nameType>
      </personName>
      <identifiers>
        <idType>EIN</idType>
        <idValue>98-7654329</idValue>
        <isPrimary>Y</isPrimary>
      </identifiers>
      <division>HC</division>
      <birthDate>1980-03-24</birthDate>
      <sinceDate>2019-01-01</sinceDate>
      <address>
        <addressEffDate>2019-01-01</addressEffDate>
        <addressType>MAIN</addressType>
        <mailingName>Antartica Petroleum Corp</mailingName>
        <address1>Saturn Park</address1>
        <address2>Saturn Street</address2>
        <address3>River Side</address3>
        <address4></address4>
        <city>San Francisco</city>
        <state>CA</state>
        <zip>94122</zip>
        <country>USA</country>
      </address>
      <email>apc@example.com</email>
      <overrideMailingName1>Antartica Petroleum Corporation</
overrideMailingName1>
      <overrideMailingName2></overrideMailingName2>
      <overrideMailingName3></overrideMailingName3>
      <phones>
        <phoneType>BUSN</phoneType>
        <phoneValue>415-555-0100</phoneValue>
      </phones>
      <relatedPersons>
        <idType></idType>
        <idValue></idValue>
        <personRelationshipType></personRelationshipType>
        <startDate></startDate>
        <endDate></endDate>
        <financialRelationshipSw></financialRelationshipSw>
        <parentOrChild></parentOrChild>
        <characteristics>
          <characteristicsList>
            <characteristicType></characteristicType>
            <characteristicValue></characteristicValue>
            <effectiveDate></effectiveDate>
          </characteristicsList>
        </characteristics>
      </relatedPersons>
      <characteristics>

```

```

    <characteristicsList>
      <characteristicType>PER_CAT</characteristicType>
      <characteristicValue>EMPOLYER</characteristicValue>
      <effectiveDate>2019-01-01</effectiveDate>
    </characteristicsList>
  </characteristics>
  <accountData>
    <accountType></accountType>
    <customerClass></customerClass>
    <billCycle></billCycle>
    <billLeadDays></billLeadDays>
    <division></division>
    <currency></currency>
    <setUpDate></setUpDate>
    <acctUsageFlg></acctUsageFlg>
    <comments></comments>
    <deferAutoPayDt></deferAutoPayDt>
    <collectionClass></collectionClass>
    <billRouteType></billRouteType>
    <billAddressSource></billAddressSource>
    <identifiers>
      <idType></idType>
      <idValue></idValue>
      <isPrimary></isPrimary>
    </identifiers>
    <address>
      <addressEffDate></addressEffDate>
      <addressType></addressType>
      <address1></address1>
      <address2></address2>
      <address3></address3>
      <address4></address4>
      <city></city>
      <state></state>
      <zip></zip>
      <country></country>
    </address>
    <autoPayDetails>
      <priority></priority>
      <startDate></startDate>
      <endDate></endDate>
      <percentage></percentage>
      <autoPayMethod></autoPayMethod>
      <autoPayRouteType></autoPayRouteType>
      <autoPaySourceCode></autoPaySourceCode>
      <accountNumber></accountNumber>
      <expiryMonth></expiryMonth>
      <expiryYear></expiryYear>
      <name></name>
      <maxWithdrawalAmount></maxWithdrawalAmount>
      <comments></comments>
    </autoPayDetails>
    <accountPerson>
      <idType></idType>
      <idValue></idValue>
      <accountRelationshipType></accountRelationshipType>
      <isFinanciallyResponsible></isFinanciallyResponsible>
      <personAddressOverride>
        <address1></address1>
        <address2></address2>
        <address3></address3>
        <address4></address4>
        <city></city>
        <postal></postal>
      </personAddressOverride>
    </accountPerson>
  </accountData>

```

```

        <state></state>
        <country></country>
    </personAddressOverride>
    <accountPersonRouting>
        <billRouteType></billRouteType>
        <shouldReceiveCopyOfBill></
shouldReceiveCopyOfBill>
        <billFormat></billFormat>
        <numberOfBillCopies></numberOfBillCopies>
        <receivesNotification></receivesNotification>
        <billAddressSource></billAddressSource>
    </accountPersonRouting>
</accountPerson>
<characteristics>
    <characteristicsList>
        <characteristicType></characteristicType>
        <characteristicValue></characteristicValue>
        <effectiveDate></effectiveDate>
    </characteristicsList>
</characteristics>
</accountData>
<policyData>
    <policyType>GROUP CUSTOMER</policyType>
    <sourceSystem>SMALLPRIME</sourceSystem>
    <policyNumber>AP234356</policyNumber>
    <description>Active Employee Medical Health Care Policy</
description>
    <startDate>2019-01-01</startDate>
    <endDate>2019-12-31</endDate>
    <policyPersons>
        <idType></idType>
        <idValue></idValue>
        <policyPerRole></policyPerRole>
        <startDate></startDate>
        <endDate></endDate>
    </policyPersons>
    <terminationInformation>
        <terminateDate></terminateDate>
        <terminationReason></terminationReason>
    </terminationInformation>
    <reinstateInformation>
        <reinstatementDate></reinstatementDate>
        <reinstateReason></reinstateReason>
    </reinstateInformation>
    <characteristics>
        <characteristicsList>
            <characteristicType>C1PRBASE</characteristicType>
            <characteristicValue>Y</characteristicValue>
            <effectiveDate>2019-01-01</effectiveDate>
        </characteristicsList>
        <characteristicsList>
            <characteristicType>C1STISSE</characteristicType>
            <characteristicValue>VG</characteristicValue>
            <effectiveDate>2019-01-01</effectiveDate>
        </characteristicsList>
    </characteristics>
    <planData>
        <planNumber>HMO_MED_BRONZE</planNumber>
        <priceItemCode></priceItemCode>
        <planName>HMO Medical Bronze 60 AE</planName>
        <pricingRuleTypeList>
            <pricingRuleType>AGE_BASED</pricingRuleType>
        </pricingRuleTypeList>
        <startDate>2019-01-01</startDate>

```

```

        <endDate>2019-12-31</endDate>
        <primaryPlanSw>N</primaryPlanSw>
        <characteristics>
            <characteristicsList>
                <characteristicType>C1HPLNID</
characteristicType>
                <characteristicValue>010</
characteristicValue>
                <effectiveDate>2019-01-01</effectiveDate>
            </characteristicsList>
        </characteristics>
    </planData>
    <planData>
        <planNumber>HMO_MED_SILVER</planNumber>
        <priceItemCode></priceItemCode>
        <planName>HMO Medical Silver 70 AE</planName>
        <pricingRuleTypeList>
            <pricingRuleType>AGE_BASED</pricingRuleType>
        </pricingRuleTypeList>
        <startDate>2019-01-01</startDate>
        <endDate>2019-12-31</endDate>
        <primaryPlanSw>N</primaryPlanSw>
        <characteristics>
            <characteristicsList>
                <characteristicType>C1HPLNID</
characteristicType>
                <characteristicValue>020</characteristicValue>
                <effectiveDate>2019-01-01</effectiveDate>
            </characteristicsList>
        </characteristics>
    </planData>
    <planData>
        <planNumber>HMO_MED_GOLD</planNumber>
        <priceItemCode></priceItemCode>
        <planName>HMO Medical Gold 80 AE</planName>
        <pricingRuleTypeList>
            <pricingRuleType>AGE_BASED</pricingRuleType>
        </pricingRuleTypeList>
        <startDate>2019-01-01</startDate>
        <endDate>2019-12-31</endDate>
        <primaryPlanSw>N</primaryPlanSw>
        <characteristics>
            <characteristicsList>
                <characteristicType>C1HPLNID</
characteristicType>
                <characteristicValue>030</characteristicValue>
                <effectiveDate>2019-01-01</effectiveDate>
            </characteristicsList>
        </characteristics>
    </planData>
    <planData>
        <planNumber>HMO_MED_PLATINUM</planNumber>
        <priceItemCode></priceItemCode>
        <planName>HMO Medical Platinum 90 AE</planName>
        <pricingRuleTypeList>
            <pricingRuleType>AGE_BASED</pricingRuleType>
        </pricingRuleTypeList>
        <startDate>2019-01-01</startDate>
        <endDate>2019-12-31</endDate>
        <primaryPlanSw>N</primaryPlanSw>
        <characteristics>
            <characteristicsList>
                <characteristicType>C1HPLNID</
characteristicType>

```

```

                <characteristicValue>040</characteristicValue>
                <effectiveDate>2019-01-01</effectiveDate>
            </characteristicsList>
        </characteristics>
    </planData>
    <planData>
        <planNumber>PPO_MED_BRONZE</planNumber>
        <priceItemCode></priceItemCode>
        <planName>PPO Medical Bronze 60 AE</planName>
        <pricingRuleTypeList>
            <pricingRuleType>AGE_BASED</pricingRuleType>
        </pricingRuleTypeList>
        <startDate>2019-01-01</startDate>
        <endDate>2019-12-31</endDate>
        <primaryPlanSw>N</primaryPlanSw>
        <characteristics>
            <characteristicsList>
                <characteristicType>C1HPLNID</
characteristicType>
                <characteristicValue>050</characteristicValue>
                <effectiveDate>2019-01-01</effectiveDate>
            </characteristicsList>
        </characteristics>
    </planData>
    <planData>
        <planNumber>PPO_MED_SILVER</planNumber>
        <priceItemCode></priceItemCode>
        <planName>PPO Medical Silver 70 AE</planName>
        <pricingRuleTypeList>
            <pricingRuleType>AGE_BASED</pricingRuleType>
        </pricingRuleTypeList>
        <startDate>2019-01-01</startDate>
        <endDate>2019-12-31</endDate>
        <primaryPlanSw>N</primaryPlanSw>
        <characteristics>
            <characteristicsList>
                <characteristicType>C1HPLNID</
characteristicType>
                <characteristicValue>060</characteristicValue>
                <effectiveDate>2019-01-01</effectiveDate>
            </characteristicsList>
        </characteristics>
    </planData>
    <planData>
        <planNumber>PPO_MED_GOLD</planNumber>
        <priceItemCode></priceItemCode>
        <planName>PPO Medical Gold 80 AE</planName>
        <pricingRuleTypeList>
            <pricingRuleType>AGE_BASED</pricingRuleType>
        </pricingRuleTypeList>
        <startDate>2019-01-01</startDate>
        <endDate>2019-12-31</endDate>
        <primaryPlanSw>N</primaryPlanSw>
        <characteristics>
            <characteristicsList>
                <characteristicType>C1HPLNID</
characteristicType>
                <characteristicValue>070</characteristicValue>
                <effectiveDate>2019-01-01</effectiveDate>
            </characteristicsList>
        </characteristics>
    </planData>
    <planData>
        <planNumber>PPO_MED_PLATINUM</planNumber>

```



```

        <priceItemCode></priceItemCode>
        <planName>PPO Medical Platinum 90 AE</planName>
        <pricingRuleTypeList>
            <pricingRuleType>AGE_BASED</pricingRuleType>
        </pricingRuleTypeList>
        <startDate>2019-01-01</startDate>
        <endDate>2019-12-31</endDate>
        <primaryPlanSw>N</primaryPlanSw>
        <characteristics>
            <characteristicsList>
                <characteristicType>C1HPLNID</
characteristicType>
                    <characteristicValue>080</characteristicValue>
                    <effectiveDate>2019-01-01</effectiveDate>
                </characteristicsList>
            </characteristics>
        </planData>
    </policyData>
    <policyData>
        <policyType>GROUP CUSTOMER</policyType>
        <sourceSystem>SMALLPRIME</sourceSystem>
        <policyNumber>AP234345</policyNumber>
        <description>Active Employee Dental Health Care Policy</
description>
        <startDate>2019-01-01</startDate>
        <endDate>2019-12-31</endDate>
        <policyPersons>
            <idType></idType>
            <idValue></idValue>
            <policyPerRole></policyPerRole>
            <startDate></startDate>
            <endDate></endDate>
        </policyPersons>
        <terminationInformation>
            <terminateDate></terminateDate>
            <terminationReason></terminationReason>
        </terminationInformation>
        <reinstateInformation>
            <reinstatementDate></reinstatementDate>
            <reinstateReason></reinstateReason>
        </reinstateInformation>
        <characteristics>
            <characteristicsList>
                <characteristicType>C1PRBASE</characteristicType>
                <characteristicValue>Y</characteristicValue>
                <effectiveDate>2019-01-01</effectiveDate>
            </characteristicsList>
            <characteristicsList>
                <characteristicType>C1STISSE</characteristicType>
                <characteristicValue>VG</characteristicValue>
                <effectiveDate>2019-01-01</effectiveDate>
            </characteristicsList>
            <characteristicsList>
                <characteristicType>C1PRTNRL</characteristicType>
                <characteristicValue>M</characteristicValue>
                <effectiveDate>2019-01-01</effectiveDate>
            </characteristicsList>
        </characteristics>
    </planData>
    <planNumber>DD_BASIC</planNumber>
    <priceItemCode></priceItemCode>
    <planName>DD BASIC PLAN AE</planName>
    <pricingRuleTypeList>
        <pricingRuleType>TIER_BASED</pricingRuleType>

```

```

        </pricingRuleTypeList>
        <startDate>2019-01-01</startDate>
        <endDate>2019-12-31</endDate>
        <primaryPlanSw>N</primaryPlanSw>
        <characteristics>
          <characteristicsList>
            <characteristicType>C1HPLNID</
characteristicType>
              <characteristicValue>090</characteristicValue>
              <effectiveDate>2019-01-01</effectiveDate>
            </characteristicsList>
          </characteristics>
        </planData>
        <planData>
          <planNumber>DD_STD</planNumber>
          <priceItemCode></priceItemCode>
          <planName>DD STANDARD PLAN AE</planName>
          <pricingRuleTypeList>
            <pricingRuleType>TIER_BASED</pricingRuleType>
          </pricingRuleTypeList>
          <startDate>2019-01-01</startDate>
          <endDate>2019-12-31</endDate>
          <primaryPlanSw>N</primaryPlanSw>
          <characteristics>
            <characteristicsList>
              <characteristicType>C1HPLNID</
characteristicType>
                <characteristicValue>100</characteristicValue>
                <effectiveDate>2019-01-01</effectiveDate>
              </characteristicsList>
            </characteristics>
          </planData>
        </policyData>
        <policyData>
          <policyType>GROUP CUSTOMER</policyType>
          <sourceSystem>SMALLPRIME</sourceSystem>
          <policyNumber>AP234389</policyNumber>
          <description>Retiree Employee Health Care Policy</
description>
          <startDate>2019-01-01</startDate><endDate>2019-12-31</
endDate>
          <policyPersons>
            <idType></idType>
            <idValue></idValue>
            <policyPerRole></policyPerRole>
            <startDate></startDate>
            <endDate></endDate>
          </policyPersons>
          <terminationInformation>
            <terminateDate></terminateDate>
            <terminationReason></terminationReason>
          </terminationInformation>
          <reinstateInformation>
            <reinstatementDate></reinstatementDate>
            <reinstateReason></reinstateReason>
          </reinstateInformation>
          <characteristics>
            <characteristicsList>
              <characteristicType>C1PRBASE</characteristicType>
              <characteristicValue>Y</characteristicValue>
              <effectiveDate>2019-01-01</effectiveDate>
            </characteristicsList>
          <characteristicsList>
            <characteristicType>C1STISSE</characteristicType>

```

```

        <characteristicValue>VG</characteristicValue>
        <effectiveDate>2019-01-01</effectiveDate>
    </characteristicsList>
</characteristics>
<planData>
    <planNumber>HMO_MED_BRONZE_RETIREDC</planNumber>
    <priceItemCode></priceItemCode>
    <planName>HMO Medical Bronze 60 RE</planName>
    <pricingRuleTypeList>
        <pricingRuleType>AGE_BASED</pricingRuleType>
    </pricingRuleTypeList>
    <startDate>2019-01-01</startDate>
    <endDate>2019-12-31</endDate>
    <primaryPlanSw>N</primaryPlanSw>
    <characteristics>
        <characteristicsList>
            <characteristicType>C1HPLNID</characteristicType>
            <characteristicValue>120</characteristicValue>
            <effectiveDate>2019-01-01</effectiveDate>
        </characteristicsList>
    </characteristics>
</planData>
<planData>
    <planNumber>HMO_MED_SILVER_RETIREDC</planNumber>
    <priceItemCode></priceItemCode>
    <planName>HMO Medical Silver 70 RE</planName>
    <pricingRuleTypeList>
        <pricingRuleType>AGE_BASED</pricingRuleType>
    </pricingRuleTypeList>
    <startDate>2019-01-01</startDate>
    <endDate>2019-12-31</endDate>
    <primaryPlanSw>N</primaryPlanSw>
    <characteristics>
        <characteristicsList>
            <characteristicType>C1HPLNID</characteristicType>
            <characteristicValue>140</characteristicValue>
            <effectiveDate>2019-01-01</effectiveDate>
        </characteristicsList>
    </characteristics>
</planData>
<planData>
    <planNumber>PPO_MED_BRONZE_RETIREDC</planNumber>
    <priceItemCode></priceItemCode>
    <planName>PPO Medical Bronze 60 RE</planName>
    <pricingRuleTypeList>
        <pricingRuleType>AGE_BASED</pricingRuleType>
    </pricingRuleTypeList>
    <startDate>2019-01-01</startDate>
    <endDate>2019-12-31</endDate>
    <primaryPlanSw>N</primaryPlanSw>
    <characteristics>
        <characteristicsList>
            <characteristicType>C1HPLNID/<
characteristicType>
            <characteristicValue>160</characteristicValue>
            <effectiveDate>2019-01-01</effectiveDate>
        </characteristicsList>
    </characteristics>
</planData>
<planData>
    <planNumber>PPO_MED_SILVER_RETIREDC</planNumber>
    <priceItemCode></priceItemCode>
    <planName>PPO Medical Silver 70 RE</planName>
    <pricingRuleTypeList>

```

```

        <pricingRuleType>AGE_BASED</pricingRuleType>
    </pricingRuleTypeList>
    <startDate>2019-01-01</startDate>
    <endDate>2019-12-31</endDate>
    <primaryPlanSw>N</primaryPlanSw>
    <characteristics>
        <characteristicsList>
            <characteristicType>C1HPLNID</
characteristicType>
                <characteristicValue>180</characteristicValue>
                <effectiveDate>2019-01-01</effectiveDate>
            </characteristicsList>
        </characteristics>
    </planData>
    <planData>
        <planNumber>DD_BASIC_RETIRED</planNumber>
        <priceItemCode></priceItemCode>
        <planName>DD BASIC RE</planName>
        <pricingRuleTypeList>
            <pricingRuleType>TIER_BASED</pricingRuleType>
        </pricingRuleTypeList>
        <startDate>2019-01-01</startDate>
        <endDate>2019-12-31</endDate>
        <primaryPlanSw>N</primaryPlanSw>
        <characteristics>
            <characteristicsList>
                <characteristicType>C1HPLNID</
characteristicType>
                    <characteristicValue>200</characteristicValue>
                    <effectiveDate>2019-01-01</effectiveDate>
                </characteristicsList>
            </characteristics>
        </planData>
    </policyData>
</personData>
<personData>
    <sequence>2</sequence>
    <personType>BG</personType>
    <personName>
        <sequence>1</sequence>
        <entityName>Antartica Petroleum ACTIVE</entityName>
        <nameType>PRIM</nameType>
    </personName>
    <identifiers>
        <idType>EIN</idType>
        <idValue>98-7654320</idValue>
        <isPrimary>Y</isPrimary>
    </identifiers>
    <division>HC</division>
    <birthDate>1991-05-09</birthDate>
    <sinceDate>2019-01-01</sinceDate>
    <address>
        <addressEffDate>2019-01-01</addressEffDate>
        <addressType>MAIN</addressType>
        <mailingName>Antartica Petroleum ACTIVE</mailingName>
        <address1>Mars Park</address1>
        <address2>Mars Street</address2>
        <address3>Lake Side</address3>
        <address4></address4>
        <city>Los Angeles</city>
        <state>CA</state>
        <zip>90020</zip>
        <country>USA</country>
    </address>

```

```

<email>apcac@example.com</email>
<overrideMailingName1></overrideMailingName1>
<overrideMailingName2></overrideMailingName2>
<overrideMailingName3></overrideMailingName3>
<phones>
  <phoneType>BUSN</phoneType>
  <phoneValue>661-555-0111</phoneValue>
</phones>
<relatedPersons>
  <idType>EIN</idType>
  <idValue>98-7654329</idValue>
  <personRelationshipType></personRelationshipType>
  <startDate>2019-01-01</startDate>
  <endDate>2019-12-31</endDate>
  <financialRelationshipSw>>false</financialRelationshipSw>
  <parentOrChild>P</parentOrChild>
  <characteristics>
    <characteristicsList>
      <characteristicType></characteristicType>
      <characteristicValue></characteristicValue>
      <effectiveDate></effectiveDate>
    </characteristicsList>
  </characteristics>
</relatedPersons>
<characteristics>
  <characteristicsList>
    <characteristicValue>OTHER</characteristicValue>
    <characteristicType>PER_CAT</characteristicType>
    <effectiveDate>2019-01-01</effectiveDate>
  </characteristicsList>
</characteristics>
<billLevelParameters>
  <sequence>1</sequence>
  <sourceSystem>SMALLPRIME</sourceSystem>
  <billLevelInfo1>ACTIVE</billLevelInfo1>
  <billLevelInfo2>SEATTLE</billLevelInfo2>
  <billLevelInfo3>MEDICAL</billLevelInfo3>
  <billLevelInfo4>HMO</billLevelInfo4>
  <effectiveDate>2019-01-01</effectiveDate>
</billLevelParameters>
<billLevelParameters>
  <sequence>2</sequence>
  <sourceSystem>SMALLPRIME</sourceSystem>
  <billLevelInfo1>ACTIVE</billLevelInfo1>
  <billLevelInfo2>SEATTLE</billLevelInfo2>
  <billLevelInfo3>MEDICAL</billLevelInfo3>
  <billLevelInfo4>PPO</billLevelInfo4>
  <effectiveDate>2019-01-01</effectiveDate>
</billLevelParameters>
<billLevelParameters>
  <sequence>3</sequence>
  <sourceSystem>SMALLPRIME</sourceSystem>
  <billLevelInfo1>ACTIVE</billLevelInfo1>
  <billLevelInfo2>SEATTLE</billLevelInfo2>
  <billLevelInfo3>DENTAL</billLevelInfo3>
  <billLevelInfo4>HMO</billLevelInfo4>
  <effectiveDate>2019-01-01</effectiveDate>
</billLevelParameters>
<billLevelParameters>
  <sequence>4</sequence>
  <sourceSystem>SMALLPRIME</sourceSystem>
  <billLevelInfo1>ACTIVE</billLevelInfo1>
  <billLevelInfo2>SEATTLE</billLevelInfo2>
  <billLevelInfo3>DENTAL</billLevelInfo3>

```

```

        <billLevelInfo4>PPO</billLevelInfo4>
        <effectiveDate>2019-01-01</effectiveDate>
    </billLevelParameters>
    <billLevelParameters>
        <sequence>5</sequence>
        <sourceSystem>SMALLPRIME</sourceSystem>
        <billLevelInfo1>ACTIVE</billLevelInfo1>
        <billLevelInfo2>SAN FRANCISCO</billLevelInfo2>
        <billLevelInfo3>MEDICAL</billLevelInfo3>
        <billLevelInfo4>HMO</billLevelInfo4>
        <effectiveDate>2019-01-01</effectiveDate>
    </billLevelParameters>
    <billLevelParameters>
        <sequence>6</sequence>
        <sourceSystem>SMALLPRIME</sourceSystem>
        <billLevelInfo1>ACTIVE</billLevelInfo1>
        <billLevelInfo2>SAN FRANCISCO</billLevelInfo2>
        <billLevelInfo3>MEDICAL</billLevelInfo3>
        <billLevelInfo4>PPO</billLevelInfo4>
        <effectiveDate>2019-01-01</effectiveDate>
    </billLevelParameters>
    <billLevelParameters>
        <sequence>7</sequence>
        <sourceSystem>SMALLPRIME</sourceSystem>
        <billLevelInfo1>ACTIVE</billLevelInfo1>
        <billLevelInfo2>SAN FRANCISCO</billLevelInfo2>
        <billLevelInfo3>DENTAL</billLevelInfo3>
        <billLevelInfo4>HMO</billLevelInfo4>
        <effectiveDate>2019-01-01</effectiveDate>
    </billLevelParameters>
    <billLevelParameters>
        <sequence>8</sequence>
        <sourceSystem>SMALLPRIME</sourceSystem>
        <billLevelInfo1>ACTIVE</billLevelInfo1>
        <billLevelInfo2>SAN FRANCISCO</billLevelInfo2>
        <billLevelInfo3>DENTAL</billLevelInfo3>
        <billLevelInfo4>PPO</billLevelInfo4>
        <effectiveDate>2019-01-01</effectiveDate>
    </billLevelParameters>
    <billLevelParameters>
        <sequence>9</sequence>
        <sourceSystem>SMALLPRIME</sourceSystem>
        <billLevelInfo1>ACTIVE</billLevelInfo1>
        <billLevelInfo2>LOS ANGELES</billLevelInfo2>
        <billLevelInfo3>MEDICAL</billLevelInfo3>
        <billLevelInfo4>HMO</billLevelInfo4>
        <effectiveDate>2019-01-01</effectiveDate>
    </billLevelParameters>
    <billLevelParameters>
        <sequence>10</sequence>
        <sourceSystem>SMALLPRIME</sourceSystem>
        <billLevelInfo1>ACTIVE</billLevelInfo1>
        <billLevelInfo2>LOS ANGELES</billLevelInfo2>
        <billLevelInfo3>MEDICAL</billLevelInfo3>
        <billLevelInfo4>PPO</billLevelInfo4>
        <effectiveDate>2019-01-01</effectiveDate>
    </billLevelParameters>
    <billLevelParameters>
        <sequence>11</sequence>
        <sourceSystem>SMALLPRIME</sourceSystem>
        <billLevelInfo1>ACTIVE</billLevelInfo1>
        <billLevelInfo2>LOS ANGELES</billLevelInfo2>
        <billLevelInfo3>DENTAL</billLevelInfo3>
        <billLevelInfo4>HMO</billLevelInfo4>

```

```

    <effectiveDate>2019-01-01</effectiveDate>
  </billLevelParameters>
  <billLevelParameters>
    <sequence>12</sequence>
    <sourceSystem>SMALLPRIME</sourceSystem>
    <billLevelInfo1>ACTIVE</billLevelInfo1>
    <billLevelInfo2>LOS ANGELES</billLevelInfo2>
    <billLevelInfo3>DENTAL</billLevelInfo3>
    <billLevelInfo4>PPO</billLevelInfo4>
    <effectiveDate>2019-01-01</effectiveDate>
  </billLevelParameters>
  <accountData>
    <accountType>CMS</accountType>
    <customerClass>HC</customerClass>
    <billCycle>BK01</billCycle>
    <billLeadDays>10</billLeadDays>
    <division>HC</division>
    <currency>USD</currency>
    <setUpDate>2019-01-01</setUpDate>
    <acctUsageFlg>USAG</acctUsageFlg>
    <comments></comments>
    <deferAutoPayDt></deferAutoPayDt>
    <collectionClass></collectionClass>
    <billRouteType>POSTAL</billRouteType>
    <billAddressSource>PER</billAddressSource>
    <identifiers>
      <idType>ACCT_NM</idType>
      <idValue>Medical Account</idValue>
      <isPrimary>true</isPrimary>
    </identifiers>
    <address>
      <addressEffDate>2019-01-01</addressEffDate>
      <addressType></addressType>
      <address1></address1>
      <address2>Fresno</address2>
      <address3></address3>
      <address4></address4>
      <city></city>
      <state></state>
      <zip></zip>
      <country></country>
    </address>
  </accountData>
  <accountData>
    <accountType>CMR</accountType>
    <customerClass>HC</customerClass>
    <billCycle>BK02</billCycle>
    <billLeadDays>10</billLeadDays>
    <division>HC</division>
    <currency>USD</currency>
    <setUpDate>2019-01-01</setUpDate>
    <acctUsageFlg>USAG</acctUsageFlg>
    <comments></comments>
    <deferAutoPayDt></deferAutoPayDt>
    <collectionClass></collectionClass>
    <billRouteType>POSTAL</billRouteType>
    <billAddressSource>ACOV</billAddressSource>
    <identifiers>
      <idType>ACCT_NM</idType>
      <idValue>Dental Account</idValue>
      <isPrimary>true</isPrimary>
    </identifiers>
    <address>
      <addressEffDate>2019-01-01</addressEffDate>

```

```

        <addressType>OVRD</addressType>
        <address1>Jupiter Park<</address1>
        <address2>Jupiter Street</address2>
        <address3>Near Corporation Bank</address3>
        <address4></address4>
        <city>Los Angeles</city>
        <state>CA</state>
        <zip>90020</zip>
        <country>USA</country>
    </address>
</accountData>
</personData>
<personData>
    <sequence>3</sequence>
    <personType>BG</personType>
    <personName>
        <sequence>1</sequence>
        <entityName>Antartica Petroleum COBRA</entityName>
        <nameType>PRIM</nameType>
    </personName>
    <identifiers>
        <idType>EIN</idType>
        <idValue>98-7654321</idValue>
        <isPrimary>Y</isPrimary>
    </identifiers>
    <division>HC</division>
    <birthDate>1976-01-12</birthDate>
    <sinceDate>2019-01-01</sinceDate>
    <address>
        <addressEffDate>2019-01-01</addressEffDate>
        <addressType>MAIN</addressType>
        <mailingName>Antartica Petroleum COBRA</mailingName>
        <address1>Venus Park</address1>
        <address2>Venus Street</address2>
        <address3>Lake Side</address3>
        <address4></address4>
        <city>Los Angeles</city>
        <state>CA</state>
        <zip>90020</zip>
        <country>USA</country>
    </address>
    <email>apcco@example.com</email>
    <overrideMailingName1></overrideMailingName1>
    <overrideMailingName2></overrideMailingName2>
    <overrideMailingName3></overrideMailingName3>
    <phones>
        <phoneType>BUSN</phoneType>
        <phoneValue>213-555-0175</phoneValue>
    </phones>
    <relatedPersons>
        <idType>EIN</idType>
        <idValue>98-7654329</idValue>
        <personRelationshipType></personRelationshipType>
        <startDate>2019-01-01</startDate>
        <endDate>2019-12-31</endDate>
        <financialRelationshipSw>>false</financialRelationshipSw>
        <parentOrChild>P</parentOrChild>
        <characteristics>
            <characteristicsList>
                <characteristicType></characteristicType>
                <characteristicValue></characteristicValue>
                <effectiveDate></effectiveDate>
            </characteristicsList>
        </characteristics>
    </relatedPersons>

```



```

</relatedPersons>
<characteristics>
  <characteristicsList>
    <characteristicType>PER_CAT</characteristicType>
    <characteristicValue>OTHER</characteristicValue>
    <effectiveDate>2019-01-01</effectiveDate>
  </characteristicsList>
</characteristics>
<billLevelParameters>
  <sequence>13</sequence>
  <sourceSystem>SMALLPRIME</sourceSystem>
  <billLevelInfo1>COBRA</billLevelInfo1>
  <billLevelInfo2>SEATTLE</billLevelInfo2>
  <billLevelInfo3>MEDICAL</billLevelInfo3>
  <billLevelInfo4>HMO</billLevelInfo4>
  <effectiveDate>2019-01-01</effectiveDate>
</billLevelParameters>
<billLevelParameters>
  <sequence>14</sequence>
  <sourceSystem>SMALLPRIME</sourceSystem>
  <billLevelInfo1>COBRA</billLevelInfo1>
  <billLevelInfo2>SEATTLE</billLevelInfo2>
  <billLevelInfo3>MEDICAL</billLevelInfo3>
  <billLevelInfo4>PPO</billLevelInfo4>
  <effectiveDate>2019-01-01</effectiveDate>
</billLevelParameters>
<billLevelParameters>
  <sequence>15</sequence>
  <sourceSystem>SMALLPRIME</sourceSystem>
  <billLevelInfo1>COBRA</billLevelInfo1>
  <billLevelInfo2>SEATTLE</billLevelInfo2>
  <billLevelInfo3>DENTAL</billLevelInfo3>
  <billLevelInfo4>HMO</billLevelInfo4>
  <effectiveDate>2019-01-01</effectiveDate>
</billLevelParameters>
<billLevelParameters>
  <sequence>16</sequence>
  <sourceSystem>SMALLPRIME</sourceSystem>
  <billLevelInfo1>COBRA</billLevelInfo1>
  <billLevelInfo2>SEATTLE</billLevelInfo2>
  <billLevelInfo3>DENTAL</billLevelInfo3>
  <billLevelInfo4>PPO</billLevelInfo4>
  <effectiveDate>2019-01-01</effectiveDate>
</billLevelParameters>
<billLevelParameters>
  <sequence>17</sequence>
  <sourceSystem>SMALLPRIME</sourceSystem>
  <billLevelInfo1>COBRA</billLevelInfo1>
  <billLevelInfo2>SAN FRANCISCO</billLevelInfo2>
  <billLevelInfo3>MEDICAL</billLevelInfo3>
  <billLevelInfo4>HMO</billLevelInfo4>
  <effectiveDate>2019-01-01</effectiveDate>
</billLevelParameters>
<billLevelParameters>
  <sequence>18</sequence>
  <sourceSystem>SMALLPRIME</sourceSystem>
  <billLevelInfo1>COBRA</billLevelInfo1>
  <billLevelInfo2>SAN FRANCISCO</billLevelInfo2>
  <billLevelInfo3>MEDICAL</billLevelInfo3>
  <billLevelInfo4>PPO</billLevelInfo4>
  <effectiveDate>2019-01-01</effectiveDate>
</billLevelParameters>
<billLevelParameters>
  <sequence>19</sequence>

```

```

    <sourceSystem>SMALLPRIME</sourceSystem>
    <billLevelInfo1>COBRA</billLevelInfo1>
    <billLevelInfo2>SAN FRANCISCO</billLevelInfo2>
    <billLevelInfo3>DENTAL</billLevelInfo3>
    <billLevelInfo4>HMO</billLevelInfo4>
    <effectiveDate>2019-01-01</effectiveDate>
  </billLevelParameters>
  <billLevelParameters>
    <sequence>20</sequence>
    <sourceSystem>SMALLPRIME</sourceSystem>
    <billLevelInfo1>COBRA</billLevelInfo1>
    <billLevelInfo2>SAN FRANCISCO</billLevelInfo2>
    <billLevelInfo3>DENTAL</billLevelInfo3>
    <billLevelInfo4>PPO</billLevelInfo4>
    <effectiveDate>2019-01-01</effectiveDate>
  </billLevelParameters>
  <billLevelParameters>
    <sequence>21</sequence>
    <sourceSystem>SMALLPRIME</sourceSystem>
    <billLevelInfo1>COBRA</billLevelInfo1>
    <billLevelInfo2>LOS ANGELES</billLevelInfo2>
    <billLevelInfo3>MEDICAL</billLevelInfo3>
    <billLevelInfo4>HMO</billLevelInfo4>
    <effectiveDate>2019-01-01</effectiveDate>
  </billLevelParameters>
  <billLevelParameters>
    <sequence>22</sequence>
    <sourceSystem>SMALLPRIME</sourceSystem>
    <billLevelInfo1>COBRA</billLevelInfo1>
    <billLevelInfo2>LOS ANGELES</billLevelInfo2>
    <billLevelInfo3>MEDICAL</billLevelInfo3>
    <billLevelInfo4>PPO</billLevelInfo4>
    <effectiveDate>2019-01-01</effectiveDate>
  </billLevelParameters>
  <billLevelParameters>
    <sequence>23</sequence>
    <sourceSystem>SMALLPRIME</sourceSystem>
    <billLevelInfo1>COBRA</billLevelInfo1>
    <billLevelInfo2>LOS ANGELES</billLevelInfo2>
    <billLevelInfo3>DENTAL</billLevelInfo3>
    <billLevelInfo4>HMO</billLevelInfo4>
    <effectiveDate>2019-01-01</effectiveDate>
  </billLevelParameters>
  <billLevelParameters>
    <sequence>24</sequence>
    <sourceSystem>SMALLPRIME</sourceSystem>
    <billLevelInfo1>COBRA</billLevelInfo1>
    <billLevelInfo2>LOS ANGELES</billLevelInfo2>
    <billLevelInfo3>DENTAL</billLevelInfo3>
    <billLevelInfo4>PPO</billLevelInfo4>
    <effectiveDate>2019-01-01</effectiveDate>
  </billLevelParameters>
  <accountData>
    <accountType>CMS</accountType>
    <customerClass>HC</customerClass>
    <billCycle>BK01</billCycle>
    <billLeadDays>10</billLeadDays>
    <division>HC</division>
    <currency>USD</currency>
    <setUpDate>2019-01-01</setUpDate>
    <acctUsageFlg>USAG</acctUsageFlg>
    <comments></comments>
    <deferAutoPayDt></deferAutoPayDt>
    <collectionClass></collectionClass>
  </accountData>

```

```

<billRouteType>POSTAL</billRouteType>
<billAddressSource>PER</billAddressSource>
<identifiers>
  <idType>ACCT_NM</idType>
  <idValue>Medical Account</idValue>
  <isPrimary>true</isPrimary>
</identifiers>
<address>
  <addressEffDate>2019-01-01</addressEffDate>
  <addressType></addressType>
  <address1><</address1>
  <address2></address2>
  <address3></address3>
  <address4></address4>
  <city></city>
  <state></state>
  <zip></zip>
  <country></country>
</address>
</accountData>
<accountData>
  <accountType>CMR</accountType>
  <customerClass>HC</customerClass>
  <billCycle>BK02</billCycle>
  <billLeadDays>10</billLeadDays>
  <division>HC</division>
  <currency>USD</currency>
  <setUpDate>2019-01-01</setUpDate>
  <acctUsageFlg>USAG</acctUsageFlg>
  <comments></comments>
  <deferAutoPayDt></deferAutoPayDt>
  <collectionClass></collectionClass>
  <billRouteType>POSTAL</billRouteType>
  <billAddressSource>ACOV</billAddressSource>
  <identifiers>
    <idType>ACCT_NM</idType>
    <idValue>Dental Account</idValue>
    <isPrimary>true</isPrimary>
  </identifiers>
  <address>
    <addressEffDate>2019-01-01</addressEffDate>
    <addressType>OVRD</addressType>
    <address1>Venus Park</address1>
    <address2>Venus Street</address2>
    <address3>Lake Side</address3>
    <address4></address4>
    <city>Los Angeles</city>
    <state>CA</state>
    <zip>90020</zip>
    <country>USA</country>
  </address>
</accountData>
</personData>
<personData>
  <sequence>4</sequence>
  <personType>BG</personType>
  <personName>
    <sequence>1</sequence>
    <entityName>Antartica Petroleum RETIREE</entityName>
    <nameType>PRIM</nameType>
  </personName>
  <identifiers>
    <idType>EIN</idType>
    <idValue>98-7654322</idValue>

```

```

    <isPrimary>Y</isPrimary>
  </identifiers>
  <division>HC</division>
  <birthDate>1985-01-01</birthDate>
  <sinceDate>2019-01-01</sinceDate>
  <address>
    <addressEffDate>2019-01-01</addressEffDate>
    <addressType>MAIN</addressType>
    <mailingName>Antartica Petroleum RETIREE</mailingName>
    <address1>Neptune Park</address1>
    <address2>Neptune Street</address2>
    <address3>River Side</address3>
    <address4></address4>
    <city>San Jose</city>
    <state>CA</state>
    <zip>94088</zip>
    <country>USA</country>
  </address>
  <email>apcre@example.com</email>
  <overrideMailingName1></overrideMailingName1>
  <overrideMailingName2></overrideMailingName2>
  <overrideMailingName3></overrideMailingName3>
  <phones>
    <phoneType>BUSN</phoneType>
    <phoneValue>408-555-0165</phoneValue>
  </phones>
  <relatedPersons>
    <idType>EIN</idType>
    <idValue>98-7654329</idValue>
    <personRelationshipType></personRelationshipType>
    <startDate>2019-01-01</startDate>
    <endDate>2019-12-31</endDate>
    <financialRelationshipSw>>false</financialRelationshipSw>
    <parentOrChild>P</parentOrChild>
    <characteristics>
      <characteristicsList>
        <characteristicType></characteristicType>
        <characteristicValue></characteristicValue>
        <effectiveDate></effectiveDate>
      </characteristicsList>
    </characteristics>
  </relatedPersons>
  <characteristics>
    <characteristicsList>
      <characteristicType>PER_CAT</characteristicType>
      <characteristicValue>OTHER</characteristicValue>
      <effectiveDate>2019-01-01</effectiveDate>
    </characteristicsList>
  </characteristics>
  <billLevelParameters>
    <sequence>25</sequence>
    <sourceSystem>SMALLPRIME</sourceSystem>
    <billLevelInfo1>RETIRED</billLevelInfo1>
    <billLevelInfo2>SEATTLE</billLevelInfo2>
    <billLevelInfo3>MEDICAL</billLevelInfo3>
    <billLevelInfo4>HMO</billLevelInfo4>
    <effectiveDate>2019-01-01</effectiveDate>
  </billLevelParameters>
  <billLevelParameters>
    <sequence>26</sequence>
    <sourceSystem>SMALLPRIME</sourceSystem>
    <billLevelInfo1>RETIRED</billLevelInfo1>
    <billLevelInfo2>SEATTLE</billLevelInfo2>
    <billLevelInfo3>MEDICAL</billLevelInfo3>

```

```

        <billLevelInfo4>PPO</billLevelInfo4>
        <effectiveDate>2019-01-01</effectiveDate>
    </billLevelParameters>
    <billLevelParameters>
        <sequence>27</sequence>
        <sourceSystem>SMALLPRIME</sourceSystem>
        <billLevelInfo1>RETIRED</billLevelInfo1>
        <billLevelInfo2>SEATTLE</billLevelInfo2>
        <billLevelInfo3>DENTAL</billLevelInfo3>
        <billLevelInfo4>HMO</billLevelInfo4>
        <effectiveDate>2019-01-01</effectiveDate>
    </billLevelParameters>
    <billLevelParameters>
        <sequence>28</sequence>
        <sourceSystem>SMALLPRIME</sourceSystem>
        <billLevelInfo1>RETIRED</billLevelInfo1>
        <billLevelInfo2>SEATTLE</billLevelInfo2>
        <billLevelInfo3>DENTAL</billLevelInfo3>
        <billLevelInfo4>PPO</billLevelInfo4>
        <effectiveDate>2019-01-01</effectiveDate>
    </billLevelParameters>
    <billLevelParameters>
        <sequence>29</sequence>
        <sourceSystem>SMALLPRIME</sourceSystem>
        <billLevelInfo1>RETIRED</billLevelInfo1>
        <billLevelInfo2>SAN FRANCISCO</billLevelInfo2>
        <billLevelInfo3>MEDICAL</billLevelInfo3>
        <billLevelInfo4>HMO</billLevelInfo4>
        <effectiveDate>2019-01-01</effectiveDate>
    </billLevelParameters>
    <billLevelParameters>
        <sequence>30</sequence>
        <sourceSystem>SMALLPRIME</sourceSystem>
        <billLevelInfo1>RETIRED</billLevelInfo1>
        <billLevelInfo2>SAN FRANCISCO</billLevelInfo2>
        <billLevelInfo3>MEDICAL</billLevelInfo3>
        <billLevelInfo4>PPO</billLevelInfo4>
        <effectiveDate>2019-01-01</effectiveDate>
    </billLevelParameters>
    <billLevelParameters>
        <sequence>31</sequence>
        <sourceSystem>SMALLPRIME</sourceSystem>
        <billLevelInfo1>RETIRED</billLevelInfo1>
        <billLevelInfo2>SAN FRANCISCO</billLevelInfo2>
        <billLevelInfo3>DENTAL</billLevelInfo3>
        <billLevelInfo4>HMO</billLevelInfo4>
        <effectiveDate>2019-01-01</effectiveDate>
    </billLevelParameters>
    <billLevelParameters>
        <sequence>32</sequence>
        <sourceSystem>SMALLPRIME</sourceSystem>
        <billLevelInfo1>RETIRED</billLevelInfo1>
        <billLevelInfo2>SAN FRANCISCO</billLevelInfo2>
        <billLevelInfo3>DENTAL</billLevelInfo3>
        <billLevelInfo4>PPO</billLevelInfo4>
        <effectiveDate>2019-01-01</effectiveDate>
    </billLevelParameters>
    <billLevelParameters>
        <sequence>33</sequence>
        <sourceSystem>SMALLPRIME</sourceSystem>
        <billLevelInfo1>RETIRED</billLevelInfo1>
        <billLevelInfo2>LOS ANGELES</billLevelInfo2>
        <billLevelInfo3>MEDICAL</billLevelInfo3>
        <billLevelInfo4>HMO</billLevelInfo4>

```

```

    <effectiveDate>2019-01-01</effectiveDate>
  </billLevelParameters>
  <billLevelParameters>
    <sequence>34</sequence>
    <sourceSystem>SMALLPRIME</sourceSystem>
    <billLevelInfo1>RETIRED</billLevelInfo1>
    <billLevelInfo2>LOS ANGELES</billLevelInfo2>
    <billLevelInfo3>MEDICAL</billLevelInfo3>
    <billLevelInfo4>PPO</billLevelInfo4>
    <effectiveDate>2019-01-01</effectiveDate>
  </billLevelParameters>
  <billLevelParameters>
    <sequence>35</sequence>
    <sourceSystem>SMALLPRIME</sourceSystem>
    <billLevelInfo1>RETIRED</billLevelInfo1>
    <billLevelInfo2>LOS ANGELES</billLevelInfo2>
    <billLevelInfo3>DENTAL</billLevelInfo3>
    <billLevelInfo4>HMO</billLevelInfo4>
    <effectiveDate>2019-01-01</effectiveDate>
  </billLevelParameters>
  <billLevelParameters>
    <sequence>36</sequence>
    <sourceSystem>SMALLPRIME</sourceSystem>
    <billLevelInfo1>RETIRED</billLevelInfo1>
    <billLevelInfo2>LOS ANGELES</billLevelInfo2>
    <billLevelInfo3>DENTAL</billLevelInfo3>
    <billLevelInfo4>PPO</billLevelInfo4>
    <effectiveDate>2019-01-01</effectiveDate>
  </billLevelParameters>
  <accountData>
    <accountType>CMS</accountType>
    <customerClass>HC</customerClass>
    <billCycle>BK01</billCycle>
    <billLeadDays>10</billLeadDays>
    <division>HC</division>
    <currency>USD</currency>
    <setUpDate>2019-01-01</setUpDate>
    <acctUsageFlg>USAG</acctUsageFlg>
    <comments></comments>
    <deferAutoPayDt></deferAutoPayDt>
    <collectionClass></collectionClass>
    <billRouteType>POSTAL</billRouteType>
    <billAddressSource>PER</billAddressSource>
    <identifiers>
      <idType>ACCT_NM</idType>
      <idValue>Medical Account</idValue>
      <isPrimary>true</isPrimary>
    </identifiers>
    <address>
      <addressEffDate>2019-01-01</addressEffDate>
      <addressType></addressType>
      <address1></address1>
      <address2></address2>
      <address3></address3>
      <address4></address4>
      <city></city>
      <state></state>
      <zip></zip>
      <country></country>
    </address>
  </accountData>
  <accountData>
    <accountType>CMR</accountType>
    <customerClass>HC</customerClass>

```

```

<billCycle>BK02</billCycle>
<billLeadDays>10</billLeadDays>
<division>HC</division>
<currency>USD</currency>
<setUpDate>2019-01-01</setUpDate>
<acctUsageFlg>USAG</acctUsageFlg>
<comments></comments>
<deferAutoPayDt></deferAutoPayDt>
<collectionClass></collectionClass>
<billRouteType>POSTAL</billRouteType>
<billAddressSource>ACOV</billAddressSource>
<identifiers>
  <idType>ACCT_NM</idType>
  <idValue>Dental Account</idValue>
  <isPrimary>true</isPrimary>
</identifiers>
<address>
  <addressEffDate>2019-01-01</addressEffDate>
  <addressType>OVRD</addressType>
  <address1>Saturn Park</address1>
  <address2>Saturn Street</address2>
  <address3>River Side</address3>
  <address4></address4>
  <city>San Francisco</city>
  <state>CA</state>
  <zip>94122</zip>
  <country>USA</country>
</address>
</accountData>
<policyData>
  <policyType>GROUP CUSTOMER</policyType>
  <sourceSystem>SMALLPRIME</sourceSystem>
  <policyNumber>AP234367</policyNumber>
  <description>Employee Medicare Policy</description>
  <startDate>2019-01-01</startDate>
  <endDate>2019-12-31</endDate>
  <policyPersons>
    <idType></idType>
    <idValue></idValue>
    <policyPerRole></policyPerRole>
    <startDate></startDate>
    <endDate></endDate>
  </policyPersons>
  <terminationInformation>
    <terminateDate></terminateDate>
    <terminationReason></terminationReason>
  </terminationInformation>
  <reinstateInformation>
    <reinstatementDate></reinstatementDate>
    <reinstateReason></reinstateReason>
  </reinstateInformation>
  <characteristics>
    <characteristicsList>
      <characteristicType>C1PRBASE</characteristicType>
      <characteristicValue>Y</characteristicValue>
      <effectiveDate>2019-01-01</effectiveDate>
    </characteristicsList>
    <characteristicsList>
      <characteristicType>C1STISSE</characteristicType>
      <characteristicValue>VG</characteristicValue>
      <effectiveDate>2019-01-01</effectiveDate>
    </characteristicsList>
  </characteristics>
</policyData>
<planData>

```

```

        <planNumber>APE_MEDI_BRONZE_M</planNumber>
        <priceItemCode></priceItemCode>
        <planName>APE Medicare Bronze RE MALE</planName>
        <pricingRuleTypeList>
            <pricingRuleType>AGE_BASED</pricingRuleType>
        </pricingRuleTypeList>
        <startDate>2019-01-01</startDate>
        <endDate>2019-12-31</endDate>
        <primaryPlanSw>N</primaryPlanSw>
        <characteristics>
            <characteristicsList>
                <characteristicType>C1HPLNID</
characteristicType>
                    <characteristicValue>300</characteristicValue>
                    <effectiveDate>2019-01-01</effectiveDate>
                </characteristicsList>
            </characteristics>
        </planData>
        <planData>
            <planNumber>APE_MEDI_SILVER_M</planNumber>
            <priceItemCode></priceItemCode>
            <planName>APE Medicare Silver RE MALE</planName>
            <pricingRuleTypeList>
                <pricingRuleType>AGE_BASED</pricingRuleType>
            </pricingRuleTypeList>
            <startDate>2019-01-01</startDate>
            <endDate>2019-12-31</endDate>
            <primaryPlanSw>N</primaryPlanSw>
            <characteristics>
                <characteristicsList>
                    <characteristicType>C1HPLNID</
characteristicType>
                        <characteristicValue>310</characteristicValue>
                        <effectiveDate>2019-01-01</effectiveDate>
                    </characteristicsList>
                </characteristics>
            </planData>
            <planData>
                <planNumber>APE_MEDI_GOLD_M</planNumber>
                <priceItemCode></priceItemCode>
                <planName>APE Medicare Gold RE MALE</planName>
                <pricingRuleTypeList>
                    <pricingRuleType>AGE_BASED</pricingRuleType>
                </pricingRuleTypeList>
                <startDate>2019-01-01</startDate>
                <endDate>2019-12-31</endDate>
                <primaryPlanSw>N</primaryPlanSw>
                <characteristics>
                    <characteristicsList>
                        <characteristicType>C1HPLNID</
characteristicType>
                            <characteristicValue>320</characteristicValue>
                            <effectiveDate>2019-01-01</effectiveDate>
                        </characteristicsList>
                    </characteristics>
                </planData>
                <planData>
                    <planNumber>APE_MEDI_BRONZE_F</planNumber>
                    <priceItemCode></priceItemCode>
                    <planName>APE Medicare Bronze RE FEMALE</planName>
                    <pricingRuleTypeList>
                        <pricingRuleType>AGE_BASED</pricingRuleType>
                    </pricingRuleTypeList>
                    <startDate>2019-01-01</startDate>

```



```

        <endDate>2019-12-31</endDate>
        <primaryPlanSw>N</primaryPlanSw>
        <characteristics>
            <characteristicsList>
                <characteristicType>C1HPLNID</
characteristicType>
                    <characteristicValue>330</characteristicValue>
                    <effectiveDate>2019-01-01</effectiveDate>
                </characteristicsList>
            </characteristics>
        </planData>
        <planData>
            <planNumber>APE_MEDI_SILVER_F</planNumber>
            <priceItemCode></priceItemCode>
            <planName>APE Medicare Silver RE FEMALE</planName>
            <pricingRuleTypeList>
                <pricingRuleType>AGE_BASED</pricingRuleType>
            </pricingRuleTypeList>
            <startDate>2019-01-01</startDate>
            <endDate>2019-12-31</endDate>
            <primaryPlanSw>N</primaryPlanSw>
            <characteristics>
                <characteristicsList>
                    <characteristicType>C1HPLNID</
characteristicType>
                        <characteristicValue>340</characteristicValue>
                        <effectiveDate>2019-01-01</effectiveDate>
                    </characteristicsList>
                </characteristics>
            </planData>
            <planData>
                <planNumber>APE_MEDI_GOLD_F</planNumber>
                <priceItemCode></priceItemCode>
                <planName>APE Medicare Gold RE FEMALE</planName>
                <pricingRuleTypeList>
                    <pricingRuleType>AGE_BASED</pricingRuleType>
                </pricingRuleTypeList>
                <startDate>2019-01-01</startDate>
                <endDate>2019-12-31</endDate>
                <primaryPlanSw>N</primaryPlanSw>
                <characteristics>
                    <characteristicsList>
                        <characteristicType>C1HPLNID</
characteristicType>
                            <characteristicValue>350</characteristicValue>
                            <effectiveDate>2019-01-01</effectiveDate>
                        </characteristicsList>
                    </characteristics>
                </planData>
            </policyData>
        </personData>
    </customerStructureData>
</customerStructureMessage>
</schema>

```

## Sample Health Care Inbound Message for Self-Funded Customer Setup

Using the below example, you can do the following:

- Create the parent customer and bill groups for a self-funded health care business
- Create the accounts for the bill groups
- Create the policies for the bill groups where the policy category is set to **Self-Funded**

Person Name	Person Type	Policy	Account
US Energy Corp	Parent Customer	-	-
US Energy ACTIVE	Bill Group	Active Employee Health Care Policy	Standard
			Retention
US Energy COBRA	Bill Group	Active COBRA Employee Health Care Policy	Standard
			Retention
US Energy RETIREE	Bill Group	Retiree Employee Health Care Policy	Standard
			Retention

In addition, using the below example, you can create the following derivation and pricing parameters for the above three bill groups:

Bill Group	Source System	Parameter 1	Parameter 2	Parameter 3	Parameter 4
US Energy ACTIVE	SMALLPRIME	ACTIVE	SEATTLE	-	-
	SMALLPRIME	ACTIVE	LOS ANGELES	-	-
	SMALLPRIME	ACTIVE	DALLAS	-	-
	SMALLPRIME	ACTIVE	SAN JOSE	-	-
	SMALLPRIME	ACTIVE	SAN FRANCISCO	-	-
	SMALLPRIME	ACTIVE	CHARLOTTE	-	-
	SMALLPRIME	ACTIVE	DETROIT	-	-
	SMALLPRIME	ACTIVE	CLEVELAND	-	-
	SMALLPRIME	ACTIVE	ORLANDO	-	-
	SMALLPRIME	ACTIVE	JERSEY CITY	-	-
	SMALLPRIME	ACTIVE	FONTANA	-	-
	SMALLPRIME	ACTIVE	OXNARD	-	-
US Energy COBRA	SMALLPRIME	COBRA	SEATTLE	-	-
	SMALLPRIME	COBRA	LOS ANGELES	-	-

Bill Group	Source System	Parameter 1	Parameter 2	Parameter 3	Parameter 4
	SMALLPRIME	COBRA	DALLAS	-	-
	SMALLPRIME	COBRA	SAN JOSE	-	-
	SMALLPRIME	COBRA	SAN FRANCISCO	-	-
	SMALLPRIME	COBRA	CHARLOTTE	-	-
	SMALLPRIME	COBRA	DETROIT	-	-
	SMALLPRIME	COBRA	CLEVELAND	-	-
	SMALLPRIME	COBRA	ORLANDO	-	-
	SMALLPRIME	COBRA	JERSEY CITY	-	-
	SMALLPRIME	COBRA	FONTANA	-	-
	SMALLPRIME	COBRA	OXNARD	-	-
US Energy RETIREE	SMALLPRIME	RETIRED	SEATTLE	-	-
	SMALLPRIME	RETIRED	LOS ANGELES	-	-
	SMALLPRIME	RETIRED	DALLAS	-	-
	SMALLPRIME	RETIRED	SAN JOSE	-	-
	SMALLPRIME	RETIRED	SAN FRANCISCO	-	-
	SMALLPRIME	RETIRED	CHARLOTTE	-	-
	SMALLPRIME	RETIRED	DETROIT	-	-
	SMALLPRIME	RETIRED	CLEVELAND	-	-
	SMALLPRIME	RETIRED	ORLANDO	-	-
	SMALLPRIME	RETIRED	JERSEY CITY	-	-
	SMALLPRIME	RETIRED	FONTANA	-	-
	SMALLPRIME	RETIRED	OXNARD	-	-

```

<schema>
  <bo>C1-HCInboundMessage</bo>
  <characteristics>
    <inboundMessageCharacteristic>
      <adhocCharacteristicValue></adhocCharacteristicValue>
      <characteristicType>C1-EXTBTCT</characteristicType>
      <effectiveDate>2019-01-01</effectiveDate>
    </inboundMessageCharacteristic>
  </characteristics>
</schema>

```

```

        <characteristicValue>DATAEXT4</characteristicValue>
        <characteristicValueForeignKey1></characteristicValueForeignKey1>
        <characteristicValueFK2></characteristicValueFK2>
        <characteristicValueFK3></characteristicValueFK3>
        <characteristicValueFk4></characteristicValueFk4>
        <characteristicValueFK5></characteristicValueFK5>
    </inboundMessageCharacteristic>
</characteristics>
<customerStructureMessage>
    <headerData>
        <messageType>C1-HEALTHCARE-INB-MSG-TYPE</messageType>
        <sourceSystem>SMALLPRIME</sourceSystem>
        <externalTransactionId>675376</externalTransactionId>
        <externalBatchId>898657</externalBatchId>
        <externalSourceId>656565</externalSourceId>
    </headerData>
    <customerStructureData>
        <personData>
            <sequence>1</sequence>
            <personType>PG</personType>
            <personName>
                <sequence>1</sequence>
                <entityName>US Energy Corp</entityName>
                <nameType>PRIM</nameType>
            </personName>
            <identifiers>
                <idType>EIN</idType>
                <idValue>98-7654329</idValue>
                <isPrimary>Y</isPrimary>
            </identifiers>
            <division>HC</division>
            <birthDate>1980-03-24</birthDate>
            <sinceDate>2019-01-01</sinceDate>
            <address>
                <addressEffDate>2019-01-01</addressEffDate>
                <addressType>MAIN</addressType>
                <mailingName>US Energy Corp</mailingName>
                <address1>Saturn Park</address1>
                <address2>Saturn Street</address2>
                <address3>River Side</address3>
                <address4></address4>
                <city>San Francisco</city>
                <state>CA</state>
                <zip>94122</zip>
                <country>USA</country>
            </address>
            <email>usencp@example.com</email>
            <overrideMailingName1>US Energy Corporation</
overrideMailingName1>
            <overrideMailingName2></overrideMailingName2>
            <overrideMailingName3></overrideMailingName3>
            <phones>
                <phoneType>BUSN</phoneType>
                <phoneValue>415-555-0100</phoneValue>
            </phones>
            <relatedPersons>
                <idType></idType>
                <idValue></idValue>
                <personRelationshipType></personRelationshipType>
                <startDate></startDate>
                <endDate></endDate>
                <financialRelationshipSw></financialRelationshipSw>
                <parentOrChild></parentOrChild>
            </relatedPersons>
        </personData>
    </customerStructureData>
</customerStructureMessage>

```

```

        <characteristicsList>
            <characteristicType></characteristicType>
            <characteristicValue></characteristicValue>
            <effectiveDate></effectiveDate>
        </characteristicsList>
    </characteristics>
</relatedPersons>
<characteristics>
    <characteristicsList>
        <characteristicType>PER_CAT</characteristicType>
        <characteristicValue>EMPOLYER</characteristicValue>
        <effectiveDate>2019-01-01</effectiveDate>
    </characteristicsList>
</characteristics>
</personData>
<personData>
    <sequence>2</sequence>
    <personType>BG</personType>
    <personName>
        <sequence>1</sequence>
        <entityName>US Energy ACTIVE</entityName>
        <nameType>PRIM</nameType>
    </personName>
    <identifiers>
        <idType>EIN</idType>
        <idValue>98-7654320</idValue>
        <isPrimary>Y</isPrimary>
    </identifiers>
    <division>HC</division>
    <birthDate>1991-05-09</birthDate>
    <sinceDate>2019-01-01</sinceDate>
    <address>
        <addressEffDate>2019-01-01</addressEffDate>
        <addressType>MAIN</addressType>
        <mailingName>US Energy ACTIVE</mailingName>
        <address1>Mars Park</address1>
        <address2>Mars Street</address2>
        <address3>Lake Side</address3>
        <address4></address4>
        <city>Los Angeles</city>
        <state>CA</state>
        <zip>90020</zip>
        <country>USA</country>
    </address>
    <email>usencpa@example.com</email>
    <overrideMailingName1></overrideMailingName1>
    <overrideMailingName2></overrideMailingName2>
    <overrideMailingName3></overrideMailingName3>
    <phones>
        <phoneType>BUSN</phoneType>
        <phoneValue>661-555-0111</phoneValue>
    </phones>
    <relatedPersons>
        <idType>EIN</idType>
        <idValue>98-7654329</idValue>
        <personRelationshipType></personRelationshipType>
        <startDate>2019-01-01</startDate>
        <endDate>2019-12-31</endDate>
        <financialRelationshipSw>>false</financialRelationshipSw>
        <parentOrChild>P</parentOrChild>
        <characteristics>
            <characteristicsList>
                <characteristicType></characteristicType>
                <characteristicValue></characteristicValue>
            </characteristicsList>
        </characteristics>
    </relatedPersons>
</personData>

```

```

        <effectiveDate></effectiveDate>
    </characteristicsList>
</characteristics>
</relatedPersons>
<characteristics>
    <characteristicsList>
        <characteristicType>PER_CAT</characteristicType>
        <characteristicValue>OTHER</characteristicValue>
        <effectiveDate>2019-01-01</effectiveDate>
    </characteristicsList>
</characteristics>
<billLevelParameters>
    <sequence>1</sequence>
    <sourceSystem>SMALLPRIME</sourceSystem>
    <billLevelInfo1>ACTIVE</billLevelInfo1>
    <billLevelInfo2>SEATTLE</billLevelInfo2>
    <effectiveDate>2019-01-01</effectiveDate>
</billLevelParameters>
<billLevelParameters>
    <sequence>2</sequence>
    <sourceSystem>SMALLPRIME</sourceSystem>
    <billLevelInfo1>ACTIVE</billLevelInfo1>
    <billLevelInfo2>LOS ANGELES</billLevelInfo2>
    <effectiveDate>2019-01-01</effectiveDate>
</billLevelParameters>
<billLevelParameters>
    <sequence>3</sequence>
    <sourceSystem>SMALLPRIME</sourceSystem>
    <billLevelInfo1>ACTIVE</billLevelInfo1>
    <billLevelInfo2>DALLAS</billLevelInfo2>
    <effectiveDate>2019-01-01</effectiveDate>
</billLevelParameters>
<billLevelParameters>
    <sequence>4</sequence>
    <sourceSystem>SMALLPRIME</sourceSystem>
    <billLevelInfo1>ACTIVE</billLevelInfo1>
    <billLevelInfo2>SAN JOSE</billLevelInfo2>
    <effectiveDate>2019-01-01</effectiveDate>
</billLevelParameters>
<billLevelParameters>
    <sequence>5</sequence>
    <sourceSystem>SMALLPRIME</sourceSystem>
    <billLevelInfo1>ACTIVE</billLevelInfo1>
    <billLevelInfo2>SAN FRANCISCO</billLevelInfo2>
    <effectiveDate>2019-01-01</effectiveDate>
</billLevelParameters>
<billLevelParameters>
    <sequence>6</sequence>
    <sourceSystem>SMALLPRIME</sourceSystem>
    <billLevelInfo1>ACTIVE</billLevelInfo1>
    <billLevelInfo2>CHARLOTTE</billLevelInfo2>
    <effectiveDate>2019-01-01</effectiveDate>
</billLevelParameters>
<billLevelParameters>
    <sequence>7</sequence>
    <sourceSystem>SMALLPRIME</sourceSystem>
    <billLevelInfo1>ACTIVE</billLevelInfo1>
    <billLevelInfo2>DETROIT</billLevelInfo2>
    <effectiveDate>2019-01-01</effectiveDate>
</billLevelParameters>
<billLevelParameters>
    <sequence>8</sequence>
    <sourceSystem>SMALLPRIME</sourceSystem>
    <billLevelInfo1>ACTIVE</billLevelInfo1>

```

```

    <billLevelInfo2>CLEVELAND</billLevelInfo2>
    <effectiveDate>2019-01-01</effectiveDate>
  </billLevelParameters>
  <billLevelParameters>
    <sequence>9</sequence>
    <sourceSystem>SMALLPRIME</sourceSystem>
    <billLevelInfo1>ACTIVE</billLevelInfo1>
    <billLevelInfo2>ORLANDO</billLevelInfo2>
    <effectiveDate>2019-01-01</effectiveDate>
  </billLevelParameters>
  <billLevelParameters>
    <sequence>10</sequence>
    <sourceSystem>SMALLPRIME</sourceSystem>
    <billLevelInfo1>ACTIVE</billLevelInfo1>
    <billLevelInfo2>JERSEY CITY</billLevelInfo2>
    <effectiveDate>2019-01-01</effectiveDate>
  </billLevelParameters>
  <billLevelParameters>
    <sequence>11</sequence>
    <sourceSystem>SMALLPRIME</sourceSystem>
    <billLevelInfo1>ACTIVE</billLevelInfo1>
    <billLevelInfo2>FONTANA</billLevelInfo2>
    <effectiveDate>2019-01-01</effectiveDate>
  </billLevelParameters>
  <billLevelParameters>
    <sequence>12</sequence>
    <sourceSystem>SMALLPRIME</sourceSystem>
    <billLevelInfo1>ACTIVE</billLevelInfo1>
    <billLevelInfo2>OXNARD</billLevelInfo2>
    <effectiveDate>2019-01-01</effectiveDate>
  </billLevelParameters>
  <accountData>
    <accountType>Standard</accountType>
    <customerClass>HC</customerClass>
    <billCycle>BK01</billCycle>
    <billLeadDays>10</billLeadDays>
    <division>HC</division>
    <currency>USD</currency>
    <setUpDate>2019-01-01</setUpDate>
    <acctUsageFlg>USAG</acctUsageFlg>
    <comments></comments>
    <deferAutoPayDt></deferAutoPayDt>
    <collectionClass></collectionClass>
    <billRouteType>POSTAL</billRouteType>
    <billAddressSource>PER</billAddressSource>
    <identifiers>
      <idType>ACCT_NM</idType>
      <idValue>Standard Account</idValue>
      <isPrimary>true</isPrimary>
    </identifiers>
    <address>
      <addressEffDate>2019-01-01</addressEffDate>
      <addressType></addressType>
      <address1><</address1>
      <address2>Fresno</address2>
      <address3></address3>
      <address4></address4>
      <city></city>
      <state></state>
      <zip></zip>
      <country></country>
    </address>
  </accountData>
</accountData>

```

```

<accountType>Retention</accountType>
<customerClass>HC</customerClass>
<billCycle>BK02</billCycle>
<billLeadDays>10</billLeadDays>
<division>HC</division>
<currency>USD</currency>
<setUpDate>2019-01-01</setUpDate>
<acctUsageFlg>USAG</acctUsageFlg>
<comments></comments>
<deferAutoPayDt></deferAutoPayDt>
<collectionClass></collectionClass>
<billRouteType>POSTAL</billRouteType>
<billAddressSource>ACOV</billAddressSource>
<identifiers>
  <idType>ACCT_NM</idType>
  <idValue>Retention Account</idValue>
  <isPrimary>true</isPrimary>
</identifiers>
<address>
  <addressEffDate>2019-01-01</addressEffDate>
  <addressType>OVRD</addressType>
  <address1>Jupiter Park<</address1>
  <address2>Jupiter Street</address2>
  <address3>Near Corporation Bank</address3>
  <address4></address4>
  <city>Los Angeles</city>
  <state>CA</state>
  <zip>90020</zip>
  <country>USA</country>
</address>
</accountData>
<policyData>
  <policyType>SELF-FUNDED</policyType>
  <sourceSystem>SMALLPRIME</sourceSystem>
  <policyNumber>AP234900</policyNumber>
  <description>Active Employee Health Care Policy</
description>
  <startDate>2019-01-01</startDate>
  <endDate>2019-12-31</endDate>
  <runOutEndDate>2020-03-31</runOutEndDate>
  <runOutAdminOption>NROA</runOutAdminOption>
  <renewalDate></renewalDate>
  <policyPersons>
    <idType></idType>
    <idValue></idValue>
    <policyPerRole></policyPerRole>
    <startDate></startDate>
    <endDate></endDate>
  </policyPersons>
  <characteristics>
    <characteristicsList>
      <characteristicType></characteristicType>
      <characteristicValue></characteristicValue>
      <effectiveDate></effectiveDate>
    </characteristicsList>
  </characteristics>
</policyData>
</personData>
<personData>
  <sequence>3</sequence>
  <personType>BG</personType>
  <personName>
    <sequence>1</sequence>
    <entityName>US Energy COBRA</entityName>

```



```

    <nameType>PRIM</nameType>
  </personName>
  <identifiers>
    <idType>EIN</idType>
    <idValue>98-7654321</idValue>
    <isPrimary>Y</isPrimary>
  </identifiers>
  <division>HC</division>
  <birthDate>1976-01-12</birthDate>
  <sinceDate>2019-01-01</sinceDate>
  <address>
    <addressEffDate>2019-01-01</addressEffDate>
    <addressType>MAIN</addressType>
    <mailingName>US Energy COBRA</mailingName>
    <address1>Venus Park</address1>
    <address2>Venus Street</address2>
    <address3>Lake Side</address3>
    <address4></address4>
    <city>Los Angeles</city>
    <state>CA</state>
    <zip>90020</zip>
    <country>USA</country>
  </address>
  <email>usencpco@example.com</email>
  <overrideMailingName1></overrideMailingName1>
  <overrideMailingName2></overrideMailingName2>
  <overrideMailingName3></overrideMailingName3>
  <phones>
    <phoneType>BUSN</phoneType>
    <phoneValue>213-555-0175</phoneValue>
  </phones>
  <relatedPersons>
    <idType>EIN</idType>
    <idValue>98-7654329</idValue>
    <personRelationshipType></personRelationshipType>
    <startDate>2019-01-01</startDate>
    <endDate>2019-12-31</endDate>
    <financialRelationshipSw>>false</financialRelationshipSw>
    <parentOrChild>P</parentOrChild>
    <characteristics>
      <characteristicsList>
        <characteristicType></characteristicType>
        <characteristicValue></characteristicValue>
        <effectiveDate></effectiveDate>
      </characteristicsList>
    </characteristics>
  </relatedPersons>
  <characteristics>
    <characteristicsList>
      <characteristicType>PER_CAT</characteristicType>
      <characteristicValue>OTHER</characteristicValue>
      <effectiveDate>2019-01-01</effectiveDate>
    </characteristicsList>
  </characteristics>
  <billLevelParameters>
    <sequence>13</sequence>
    <sourceSystem>SMALLPRIME</sourceSystem>
    <billLevelInfo1>COBRA</billLevelInfo1>
    <billLevelInfo2>SEATTLE</billLevelInfo2>
    <effectiveDate>2019-01-01</effectiveDate>
  </billLevelParameters>
  <billLevelParameters>
    <sequence>14</sequence>
    <sourceSystem>SMALLPRIME</sourceSystem>

```

```

    <billLevelInfo1>COBRA</billLevelInfo1>
    <billLevelInfo2>LOS ANGELES</billLevelInfo2>
    <effectiveDate>2019-01-01</effectiveDate>
  </billLevelParameters>
  <billLevelParameters>
    <sequence>15</sequence>
    <sourceSystem>SMALLPRIME</sourceSystem>
    <billLevelInfo1>COBRA</billLevelInfo1>
    <billLevelInfo2>DALLAS</billLevelInfo2>
    <effectiveDate>2019-01-01</effectiveDate>
  </billLevelParameters>
  <billLevelParameters>
    <sequence>16</sequence>
    <sourceSystem>SMALLPRIME</sourceSystem>
    <billLevelInfo1>COBRA</billLevelInfo1>
    <billLevelInfo2>SAN JOSE</billLevelInfo2>
    <effectiveDate>2019-01-01</effectiveDate>
  </billLevelParameters>
  <billLevelParameters>
    <sequence>17</sequence>
    <sourceSystem>SMALLPRIME</sourceSystem>
    <billLevelInfo1>COBRA</billLevelInfo1>
    <billLevelInfo2>SAN FRANCISCO</billLevelInfo2>
    <effectiveDate>2019-01-01</effectiveDate>
  </billLevelParameters>
  <billLevelParameters>
    <sequence>18</sequence>
    <sourceSystem>SMALLPRIME</sourceSystem>
    <billLevelInfo1>COBRA</billLevelInfo1>
    <billLevelInfo2>CHARLOTTE</billLevelInfo2>
    <effectiveDate>2019-01-01</effectiveDate>
  </billLevelParameters>
  <billLevelParameters>
    <sequence>19</sequence>
    <sourceSystem>SMALLPRIME</sourceSystem>
    <billLevelInfo1>COBRA</billLevelInfo1>
    <billLevelInfo2>DETROIT</billLevelInfo2>
    <effectiveDate>2019-01-01</effectiveDate>
  </billLevelParameters>
  <billLevelParameters>
    <sequence>20</sequence>
    <sourceSystem>SMALLPRIME</sourceSystem>
    <billLevelInfo1>COBRA</billLevelInfo1>
    <billLevelInfo2>CLEVELAND</billLevelInfo2>
    <effectiveDate>2019-01-01</effectiveDate>
  </billLevelParameters>
  <billLevelParameters>
    <sequence>21</sequence>
    <sourceSystem>SMALLPRIME</sourceSystem>
    <billLevelInfo1>COBRA</billLevelInfo1>
    <billLevelInfo2>ORLANDO</billLevelInfo2>
    <effectiveDate>2019-01-01</effectiveDate>
  </billLevelParameters>
  <billLevelParameters>
    <sequence>22</sequence>
    <sourceSystem>SMALLPRIME</sourceSystem>
    <billLevelInfo1>COBRA</billLevelInfo1>
    <billLevelInfo2>JERSEY CITY</billLevelInfo2>
    <effectiveDate>2019-01-01</effectiveDate>
  </billLevelParameters>
  <billLevelParameters>
    <sequence>23</sequence>
    <sourceSystem>SMALLPRIME</sourceSystem>
    <billLevelInfo1>COBRA</billLevelInfo1>

```

```

    <billLevelInfo2>FONTANA</billLevelInfo2>
    <effectiveDate>2019-01-01</effectiveDate>
  </billLevelParameters>
  <billLevelParameters>
    <sequence>24</sequence>
    <sourceSystem>SMALLPRIME</sourceSystem>
    <billLevelInfo1>COBRA</billLevelInfo1>
    <billLevelInfo2>OXNARD</billLevelInfo2>
    <effectiveDate>2019-01-01</effectiveDate>
  </billLevelParameters>
  <accountData>
    <accountType>Standard</accountType>
    <customerClass>HC</customerClass>
    <billCycle>BK01</billCycle>
    <billLeadDays>10</billLeadDays>
    <division>HC</division>
    <currency>USD</currency>
    <setUpDate>2019-01-01</setUpDate>
    <acctUsageFlg>USAG</acctUsageFlg>
    <comments></comments>
    <deferAutoPayDt></deferAutoPayDt>
    <collectionClass></collectionClass>
    <billRouteType>POSTAL</billRouteType>
    <billAddressSource>PER</billAddressSource>
    <identifiers>
      <idType>ACCT_NM</idType>
      <idValue>Standard Account</idValue>
      <isPrimary>true</isPrimary>
    </identifiers>
    <address>
      <addressEffDate>2019-01-01</addressEffDate>
      <addressType></addressType>
      <address1><</address1>
      <address2></address2>
      <address3></address3>
      <address4></address4>
      <city></city>
      <state></state>
      <zip></zip>
      <country></country>
    </address>
  </accountData>
  <accountData>
    <accountType>Retention</accountType>
    <customerClass>HC</customerClass>
    <billCycle>BK02</billCycle>
    <billLeadDays>10</billLeadDays>
    <division>HC</division>
    <currency>USD</currency>
    <setUpDate>2019-01-01</setUpDate>
    <acctUsageFlg>USAG</acctUsageFlg>
    <comments></comments>
    <deferAutoPayDt></deferAutoPayDt>
    <collectionClass></collectionClass>
    <billRouteType>POSTAL</billRouteType>
    <billAddressSource>ACOV</billAddressSource>
    <identifiers>
      <idType>ACCT_NM</idType>
      <idValue>Retention Account</idValue>
      <isPrimary>true</isPrimary>
    </identifiers>
    <address>
      <addressEffDate>2019-01-01</addressEffDate>
      <addressType>OVRD</addressType>

```

```

        <address1>Venus Park</address1>
        <address2>Venus Street</address2>
        <address3>Lake Side</address3>
        <address4></address4>
        <city>Los Angeles</city>
        <state>CA</state>
        <zip>90020</zip>
        <country>USA</country>
    </address>
</accountData>
<policyData>
    <policyType>SELF-FUNDED</policyType>
    <sourceSystem>SMALLPRIME</sourceSystem>
    <policyNumber>AP234902</policyNumber>
    <description>Active COBRA Employee Health Care Policy</
description>
    <startDate>2019-01-01</startDate>
    <endDate>2019-12-31</endDate>
    <runOutEndDate>2020-03-31</runOutEndDate>
    <runOutAdminOption>NROA</runOutAdminOption>
    <renewalDate></renewalDate>
    <policyPersons>
        <idType></idType>
        <idValue></idValue>
        <policyPerRole></policyPerRole>
        <startDate></startDate>
        <endDate></endDate>
    </policyPersons>
    <characteristics>
        <characteristicsList>
            <characteristicType></characteristicType>
            <characteristicValue></characteristicValue>
            <effectiveDate></effectiveDate>
        </characteristicsList>
    </characteristics>
</policyData>
<policyData>
    <policyType>SELF-FUNDED</policyType>
    <sourceSystem>SMALLPRIME</sourceSystem>
    <policyNumber>AP234903</policyNumber>
    <description>Retiree COBRA Employee Health Care Policy</
description>
    <startDate>2019-01-01</startDate>
    <endDate>2019-12-31</endDate>
    <runOutEndDate>2020-03-31</runOutEndDate>
    <runOutAdminOption>PERC</runOutAdminOption>
    <renewalDate></renewalDate>
    <policyPersons>
        <idType></idType>
        <idValue></idValue>
        <policyPerRole></policyPerRole>
        <startDate></startDate>
        <endDate></endDate>
    </policyPersons>
    <characteristics>
        <characteristicsList>
            <characteristicType></characteristicType>
            <characteristicValue></characteristicValue>
            <effectiveDate></effectiveDate>
        </characteristicsList>
    </characteristics>
</policyData>
</personData>
<personData>

```

```

<sequence>4</sequence>
<personType>BG</personType>
<personName>
  <sequence>1</sequence>
  <entityName>US Energy RETIREE</entityName>
  <nameType>PRIM</nameType>
</personName>
<identifiers>
  <idType>EIN</idType>
  <idValue>98-7654322</idValue>
  <isPrimary>Y</isPrimary>
</identifiers>
<division>HC</division>
<birthDate>1985-01-01</birthDate>
<sinceDate>2019-01-01</sinceDate>
<address>
  <addressEffDate>2019-01-01</addressEffDate>
  <addressType>MAIN</addressType>
  <mailingName>US Energy RETIREE</mailingName>
  <address1>Neptune Park</address1>
  <address2>Neptune Street</address2>
  <address3>River Side</address3>
  <address4></address4>
  <city>San Jose</city>
  <state>CA</state>
  <zip>94088</zip>
  <country>USA</country>
</address>
<email>usencpre@example.com</email>
<overrideMailingName1></overrideMailingName1>
<overrideMailingName2></overrideMailingName2>
<overrideMailingName3></overrideMailingName3>
<phones>
  <phoneType>BUSN</phoneType>
  <phoneValue>408-555-0165</phoneValue>
</phones>
<relatedPersons>
  <idType>EIN</idType>
  <idValue>98-7654329</idValue>
  <personRelationshipType></personRelationshipType>
  <startDate>2019-01-01</startDate>
  <endDate>2019-12-31</endDate>
  <financialRelationshipSw>>false</financialRelationshipSw>
  <parentOrChild>P</parentOrChild>
  <characteristics>
    <characteristicsList>
      <characteristicType></characteristicType>
      <characteristicValue></characteristicValue>
      <effectiveDate></effectiveDate>
    </characteristicsList>
  </characteristics>
</relatedPersons>
<characteristics>
  <characteristicsList>
    <characteristicType>PER_CAT</characteristicType>
    <characteristicValue>OTHER</characteristicValue>
    <effectiveDate>2019-01-01</effectiveDate>
  </characteristicsList>
</characteristics>
<billLevelParameters>
  <sequence>25</sequence>
  <sourceSystem>SMALLPRIME</sourceSystem>
  <billLevelInfo1>RETIRED</billLevelInfo1>
  <billLevelInfo2>SEATTLE</billLevelInfo2>

```

```

    <effectiveDate>2019-01-01</effectiveDate>
  </billLevelParameters>
  <billLevelParameters>
    <sequence>26</sequence>
    <sourceSystem>SMALLPRIME</sourceSystem>
    <billLevelInfo1>RETIRED</billLevelInfo1>
    <billLevelInfo2>LOS ANGELES</billLevelInfo2>
    <effectiveDate>2019-01-01</effectiveDate>
  </billLevelParameters>
  <billLevelParameters>
    <sequence>27</sequence>
    <sourceSystem>SMALLPRIME</sourceSystem>
    <billLevelInfo1>RETIRED</billLevelInfo1>
    <billLevelInfo2>DALLAS</billLevelInfo2>
    <effectiveDate>2019-01-01</effectiveDate>
  </billLevelParameters>
  <billLevelParameters>
    <sequence>28</sequence>
    <sourceSystem>SMALLPRIME</sourceSystem>
    <billLevelInfo1>RETIRED</billLevelInfo1>
    <billLevelInfo2>SAN JOSE</billLevelInfo2>
    <effectiveDate>2019-01-01</effectiveDate>
  </billLevelParameters>
  <billLevelParameters>
    <sequence>29</sequence>
    <sourceSystem>SMALLPRIME</sourceSystem>
    <billLevelInfo1>RETIRED</billLevelInfo1>
    <billLevelInfo2>SAN FRANCISCO</billLevelInfo2>
    <effectiveDate>2019-01-01</effectiveDate>
  </billLevelParameters>
  <billLevelParameters>
    <sequence>30</sequence>
    <sourceSystem>SMALLPRIME</sourceSystem>
    <billLevelInfo1>RETIRED</billLevelInfo1>
    <billLevelInfo2>CHARLOTTE</billLevelInfo2>
    <effectiveDate>2019-01-01</effectiveDate>
  </billLevelParameters>
  <billLevelParameters>
    <sequence>31</sequence>
    <sourceSystem>SMALLPRIME</sourceSystem>
    <billLevelInfo1>RETIRED</billLevelInfo1>
    <billLevelInfo2>DETROIT</billLevelInfo2>
    <effectiveDate>2019-01-01</effectiveDate>
  </billLevelParameters>
  <billLevelParameters>
    <sequence>32</sequence>
    <sourceSystem>SMALLPRIME</sourceSystem>
    <billLevelInfo1>RETIRED</billLevelInfo1>
    <billLevelInfo2>CLEVELAND</billLevelInfo2>
    <effectiveDate>2019-01-01</effectiveDate>
  </billLevelParameters>
  <billLevelParameters>
    <sequence>33</sequence>
    <sourceSystem>SMALLPRIME</sourceSystem>
    <billLevelInfo1>RETIRED</billLevelInfo1>
    <billLevelInfo2>ORLANDO</billLevelInfo2>
    <effectiveDate>2019-01-01</effectiveDate>
  </billLevelParameters>
  <billLevelParameters>
    <sequence>34</sequence>
    <sourceSystem>SMALLPRIME</sourceSystem>
    <billLevelInfo1>RETIRED</billLevelInfo1>
    <billLevelInfo2>JERSEY CITY</billLevelInfo2>
    <effectiveDate>2019-01-01</effectiveDate>
  </billLevelParameters>

```

```

</billLevelParameters>
<billLevelParameters>
  <sequence>35</sequence>
  <sourceSystem>SMALLPRIME</sourceSystem>
  <billLevelInfo1>RETIRED</billLevelInfo1>
  <billLevelInfo2>FONTANA</billLevelInfo2>
  <effectiveDate>2019-01-01</effectiveDate>
</billLevelParameters>
<billLevelParameters>
  <sequence>36</sequence>
  <sourceSystem>SMALLPRIME</sourceSystem>
  <billLevelInfo1>RETIRED</billLevelInfo1>
  <billLevelInfo2>OXNARD</billLevelInfo2>
  <effectiveDate>2019-01-01</effectiveDate>
</billLevelParameters>
<accountData>
  <accountType>Standard</accountType>
  <customerClass>HC</customerClass>
  <billCycle>BK01</billCycle>
  <billLeadDays>10</billLeadDays>
  <division>HC</division>
  <currency>USD</currency>
  <setUpDate>2019-01-01</setUpDate>
  <acctUsageFlg>USAG</acctUsageFlg>
  <comments></comments>
  <deferAutoPayDt></deferAutoPayDt>
  <collectionClass></collectionClass>
  <billRouteType>POSTAL</billRouteType>
  <billAddressSource>PER</billAddressSource>
  <identifiers>
    <idType>ACCT_NM</idType>
    <idValue>Standard Account</idValue>
    <isPrimary>true</isPrimary>
  </identifiers>
  <address>
    <addressEffDate>2019-01-01</addressEffDate>
    <addressType></addressType>
    <address1></address1>
    <address2></address2>
    <address3></address3>
    <address4></address4>
    <city></city>
    <state></state>
    <zip></zip>
    <country></country>
  </address>
</accountData>
<accountData>
  <accountType>Retention</accountType>
  <customerClass>HC</customerClass>
  <billCycle>BK02</billCycle>
  <billLeadDays>10</billLeadDays>
  <division>HC</division>
  <currency>USD</currency>
  <setUpDate>2019-01-01</setUpDate>
  <acctUsageFlg>USAG</acctUsageFlg>
  <comments></comments>
  <deferAutoPayDt></deferAutoPayDt>
  <collectionClass></collectionClass>
  <billRouteType>POSTAL</billRouteType>
  <billAddressSource>ACOV</billAddressSource>
  <identifiers>
    <idType>ACCT_NM</idType>
    <idValue>Retention Account</idValue>

```

```

        <isPrimary>true</isPrimary>
      </identifiers>
    <address>
      <addressEffDate>2019-01-01</addressEffDate>
      <addressType>OVRD</addressType>
      <address1>Saturn Park</address1>
      <address2>Saturn Street</address2>
      <address3>River Side</address3>
      <address4></address4>
      <city>San Francisco</city>
      <state>CA</state>
      <zip>94122</zip>
      <country>USA</country>
    </address>
  </accountData>
  <policyData>
    <policyType>SELF-FUNDED</policyType>
    <sourceSystem>SMALLPRIME</sourceSystem>
    <policyNumber>AP234905</policyNumber>
    <description>Retiree Employee Health Care Policy</
description>
    <startDate>2019-01-01</startDate>
    <endDate>2019-12-31</endDate>
    <runOutEndDate>2020-03-31</runOutEndDate>
    <runOutAdminOption>PERC</runOutAdminOption>
    <policyPersons>
      <idType></idType>
      <idValue></idValue>
      <policyPerRole></policyPerRole>
      <startDate></startDate>
      <endDate></endDate>
    </policyPersons>
    <characteristics>
      <characteristicsList>
        <characteristicType></characteristicType>
        <characteristicValue></characteristicValue>
        <effectiveDate></effectiveDate>
      </characteristicsList>
    </characteristics>
  </policyData>
</personData>
</customerStructureData>
</customerStructureMessage>
</schema>

```

## Sample Health Care Inbound Message for Pricing Rules

Using the below example, you can create the following:

- Tier-based pricing rule for the **DD\_BASIC** policy plan

Policy Plan	Pricing Rule Type	Base Rate	Parameter	Parameter Value
DD_BASIC	TIER_BASED	30	EMPBAND	IC1
			SUBSCRIPTIONTIER	E
			GENDER	MALE
		40	EMPBAND	IC1



Policy Plan	Pricing Rule Type	Base Rate	Parameter	Parameter Value
			SUBSCRIPTIONTIER	ES
			GENDER	MALE
		60	EMPBAND	IC1
			SUBSCRIPTIONTIER	F
			GENDER	MALE
		25	EMPBAND	IC1
			SUBSCRIPTIONTIER	E
			GENDER	FEMALE
		35	EMPBAND	IC1
			SUBSCRIPTIONTIER	ES
			GENDER	FEMALE
		50	EMPBAND	IC1
SUBSCRIPTIONTIER	F			
GENDER	FEMALE			

- Age-based pricing rule for the **PPO\_MED\_BRONZE\_RET** policy plan

Policy Plan	Pricing Rule Type	Base Rate	Lower Age Limit	Upper Age Limit	Parameter	Parameter Value	Modifier	Modifier Value	Modifier Rate
PPO_MED_BRONZE_RET	AGE_BASED	150	0	15	GENDER	FEMALE	TOBUSAGE	Y	10
		150	0	15	GENDER	MALE	TOBUSAGE	Y	20
		170	16	18	GENDER	FEMALE	TOBUSAGE	Y	20
		170	16	18	GENDER	MALE	TOBUSAGE	Y	30
		200	19	20	GENDER	FEMALE	TOBUSAGE	Y	30
		200	19	20	GENDER	MALE	TOBUSAGE	Y	40
		240	21	40	GENDER	FEMALE	TOBUSAGE	Y	40
		240	21	40	GENDER	MALE	TOBUSAGE	Y	50
		270	41	60	GENDER	FEMALE	TOBUSAGE	Y	50
		270	41	60	GENDER	MALE	TOBUSAGE	Y	60
		300	61	65	GENDER	FEMALE	TOBUSAGE	Y	60

Policy Plan	Pricing Rule Type	Base Rate	Lower Age Limit	Upper Age Limit	Parameter	Parameter Value	Modifier	Modifier Value	Modifier Rate
		300	61	65	GENDER	MALE	TOBUSAGE	Y	70
		350	66	199	GENDER	FEMALE	TOBUSAGE	Y	70
		350	66	199	GENDER	MALE	TOBUSAGE	Y	80

```

<schema>
  <bo>C1-HCInboundMessage</bo>
  <characteristics>
    <inboundMessageCharacteristic>
      <adhocCharacteristicValue></adhocCharacteristicValue>
      <characteristicType>C1-EXTBTCT</characteristicType>
      <effectiveDate>2019-01-01</effectiveDate>
      <characteristicValue>DATAEXT3</characteristicValue>
      <characteristicValueForeignKey1></characteristicValueForeignKey1>
      <characteristicValueFK2></characteristicValueFK2>
      <characteristicValueFK3></characteristicValueFK3>
      <characteristicValueFk4></characteristicValueFk4>
      <characteristicValueFK5></characteristicValueFK5>
    </inboundMessageCharacteristic>
  </characteristics>
  <customerStructureMessage>
    <headerData>
      <messageType>C1-HEALTHCARE-INB-MSG-TYPE</messageType>
      <sourceSystem>SMALLPRIME</sourceSystem>
      <externalTransactionId>12344</externalTransactionId>
      <externalBatchId>433443</externalBatchId>
      <externalSourceId>656565</externalSourceId>
    </headerData>
    <customerStructureData>
      <pricingRuleData>
        <entityType>PLAN</entityType>
        <entityIdentifier>DD_BASIC</entityIdentifier>
        <startDate>2019-01-01</startDate>
        <endDate>2019-12-31</endDate>
        <pricingRuleType>TIER_BASED</pricingRuleType>
        <priceItemCd>DEN_PREM_FEE</priceItemCd>
        <rateOption>TIERBASED</rateOption>
        <baseRate>
          <sequence>1</sequence>
          <baseFee>30</baseFee>
          <pricingParameter>
            <sequence>1</sequence>
            <parameterCode>EMPBAND</parameterCode>
            <parameterValue>IC1</parameterValue>
          </pricingParameter>
          <pricingParameter>
            <sequence>2</sequence>
            <parameterCode>SUBSCRIPTIONTIER</parameterCode>
            <parameterValue>E</parameterValue>
          </pricingParameter>
          <pricingParameter>
            <sequence>3</sequence>
            <parameterCode>GENDER</parameterCode>
            <parameterValue>MALE</parameterValue>
          </pricingParameter>
        </baseRate>
        <baseRate>
          <sequence>2</sequence>

```

```

<baseFee>40</baseFee>
<pricingParameter>
  <sequence>1</sequence>
  <parameterCode>EMPBAND</parameterCode>
  <parameterValue>IC1</parameterValue>
</pricingParameter>
<pricingParameter>
  <sequence>2</sequence>
  <parameterCode>SUBSCRIPTIONTIER</parameterCode>
  <parameterValue>ES</parameterValue>
</pricingParameter>
<pricingParameter>
  <sequence>3</sequence>
  <parameterCode>GENDER</parameterCode>
  <parameterValue>MALE</parameterValue>
</pricingParameter>
</baseRate>
<baseRate>
  <sequence>3</sequence>
  <baseFee>60</baseFee>
  <pricingParameter>
    <sequence>1</sequence>
    <parameterCode>EMPBAND</parameterCode>
    <parameterValue>IC1</parameterValue>
  </pricingParameter>
  <pricingParameter>
    <sequence>2</sequence>
    <parameterCode>SUBSCRIPTIONTIER</parameterCode>
    <parameterValue>F</parameterValue>
  </pricingParameter>
  <pricingParameter>
    <sequence>3</sequence>
    <parameterCode>GENDER</parameterCode>
    <parameterValue>MALE</parameterValue>
  </pricingParameter>
</baseRate>
<baseRate>
  <sequence>4</sequence>
  <baseFee>25</baseFee>
  <pricingParameter>
    <sequence>1</sequence>
    <parameterCode>EMPBAND</parameterCode>
    <parameterValue>IC1</parameterValue>
  </pricingParameter>
  <pricingParameter>
    <sequence>2</sequence>
    <parameterCode>SUBSCRIPTIONTIER</parameterCode>
    <parameterValue>E</parameterValue>
  </pricingParameter>
  <pricingParameter>
    <sequence>3</sequence>
    <parameterCode>GENDER</parameterCode>
    <parameterValue>FEMALE</parameterValue>
  </pricingParameter>
</baseRate>
<baseRate>
  <sequence>5</sequence>
  <baseFee>35</baseFee>
  <pricingParameter>
    <sequence>1</sequence>
    <parameterCode>EMPBAND</parameterCode>
    <parameterValue>IC1</parameterValue>
  </pricingParameter>
  <pricingParameter>

```

```

        <sequence>2</sequence>
        <parameterCode>SUBSCRIPTIONTIER</parameterCode>
        <parameterValue>ES</parameterValue>
    </pricingParameter>
</pricingParameter>
<pricingParameter>
    <sequence>3</sequence>
    <parameterCode>GENDER</parameterCode>
    <parameterValue>FEMALE</parameterValue>
</pricingParameter>
</baseRate>
<baseRate>
    <sequence>6</sequence>
    <baseFee>50</baseFee>
    <pricingParameter>
        <sequence>1</sequence>
        <parameterCode>EMPBAND</parameterCode>
        <parameterValue>IC1</parameterValue>
    </pricingParameter>
    <pricingParameter>
        <sequence>2</sequence>
        <parameterCode>SUBSCRIPTIONTIER</parameterCode>
        <parameterValue>F</parameterValue>
    </pricingParameter>
    <pricingParameter>
        <sequence>3</sequence>
        <parameterCode>GENDER</parameterCode>
        <parameterValue>FEMALE</parameterValue>
    </pricingParameter>
</baseRate>
</pricingRuleData>
<pricingRuleData>
    <entityType>PLAN</entityType>
    <entityIdentifier>PPO_MED_BRONZE_RET</entityIdentifier>
    <startDate>2019-01-01</startDate>
    <endDate>2019-12-31</endDate>
    <pricingRuleType>AGE_BASED</pricingRuleType>
    <priceItemCd>MED_PREM_FEE</priceItemCd>
    <rateOption>AGEBASED</rateOption>
    <modifierApplicability>Y</modifierApplicability>
    <modifierMethod>FLAT</modifierMethod>
    <baseRate>
        <sequence>1</sequence>
        <baseFee>150</baseFee>
        <lowerAgeLimit>0</lowerAgeLimit>
        <upperAgeLimit>15</upperAgeLimit>
        <pricingParameter>
            <sequence>1</sequence>
            <parameterCode>GENDER</parameterCode>
            <parameterValue>FEMALE</parameterValue>
        </pricingParameter>
        <modifierInformation>
            <sequence>1</sequence>
            <parameterCode>TOBUSAGE</parameterCode>
            <parameterValue>Y</parameterValue>
            <rate>10</rate>
        </modifierInformation>
    </baseRate>
    <baseRate>
        <sequence>2</sequence>
        <baseFee>150</baseFee>
        <lowerAgeLimit>0</lowerAgeLimit>
        <upperAgeLimit>15</upperAgeLimit>
        <pricingParameter>
            <sequence>1</sequence>

```

```

        <parameterCode>GENDER</parameterCode>
        <parameterValue>MALE</parameterValue>
    </pricingParameter>
    <modifierInformation>
        <sequence>1</sequence>
        <parameterCode>TOBUSAGE</parameterCode>
        <parameterValue>Y</parameterValue>
        <rate>20</rate>
    </modifierInformation>
</baseRate>
<baseRate>
    <sequence>3</sequence>
    <baseFee>170</baseFee>
    <lowerAgeLimit>16</lowerAgeLimit>
    <upperAgeLimit>18</upperAgeLimit>
    <pricingParameter>
        <sequence>1</sequence>
        <parameterCode>GENDER</parameterCode>
        <parameterValue>FEMALE</parameterValue>
    </pricingParameter>
    <modifierInformation>
        <sequence>1</sequence>
        <parameterCode>TOBUSAGE</parameterCode>
        <parameterValue>Y</parameterValue>
        <rate>20</rate>
    </modifierInformation>
</baseRate>
<baseRate>
    <sequence>4</sequence>
    <baseFee>170</baseFee>
    <lowerAgeLimit>16</lowerAgeLimit>
    <upperAgeLimit>18</upperAgeLimit>
    <pricingParameter>
        <sequence>1</sequence>
        <parameterCode>GENDER</parameterCode>
        <parameterValue>MALE</parameterValue>
    </pricingParameter>
    <modifierInformation>
        <sequence>1</sequence>
        <parameterCode>TOBUSAGE</parameterCode>
        <parameterValue>Y</parameterValue>
        <rate>30</rate>
    </modifierInformation>
</baseRate>
<baseRate>
    <sequence>5</sequence>
    <baseFee>200</baseFee>
    <lowerAgeLimit>19</lowerAgeLimit>
    <upperAgeLimit>20</upperAgeLimit>
    <pricingParameter>
        <sequence>1</sequence>
        <parameterCode>GENDER</parameterCode>
        <parameterValue>FEMALE</parameterValue>
    </pricingParameter>
    <modifierInformation>
        <sequence>1</sequence>
        <parameterCode>TOBUSAGE</parameterCode>
        <parameterValue>Y</parameterValue>
        <rate>30</rate>
    </modifierInformation>
</baseRate>
<baseRate>
    <sequence>6</sequence>
    <baseFee>200</baseFee>

```

```

<lowerAgeLimit>19</lowerAgeLimit>
<upperAgeLimit>20</upperAgeLimit>
<pricingParameter>
  <sequence>1</sequence>
  <parameterCode>GENDER</parameterCode>
  <parameterValue>MALE</parameterValue>
</pricingParameter>
<modifierInformation>
  <sequence>1</sequence>
  <parameterCode>TOBUSAGE</parameterCode>
  <parameterValue>Y</parameterValue>
  <rate>40</rate>
</modifierInformation>
</baseRate>
<baseRate>
  <sequence>7</sequence>
  <baseFee>240</baseFee>
  <lowerAgeLimit>21</lowerAgeLimit>
  <upperAgeLimit>40</upperAgeLimit>
  <pricingParameter>
    <sequence>1</sequence>
    <parameterCode>GENDER</parameterCode>
    <parameterValue>FEMALE</parameterValue>
  </pricingParameter>
  <modifierInformation>
    <sequence>1</sequence>
    <parameterCode>TOBUSAGE</parameterCode>
    <parameterValue>Y</parameterValue>
    <rate>40</rate>
  </modifierInformation>
</baseRate>
<baseRate>
  <sequence>8</sequence>
  <baseFee>240</baseFee>
  <lowerAgeLimit>21</lowerAgeLimit>
  <upperAgeLimit>40</upperAgeLimit>
  <pricingParameter>
    <sequence>1</sequence>
    <parameterCode>GENDER</parameterCode>
    <parameterValue>MALE</parameterValue>
  </pricingParameter>
  <modifierInformation>
    <sequence>1</sequence>
    <parameterCode>TOBUSAGE</parameterCode>
    <parameterValue>Y</parameterValue>
    <rate>50</rate>
  </modifierInformation>
</baseRate>
<baseRate>
  <sequence>9</sequence>
  <baseFee>270</baseFee>
  <lowerAgeLimit>41</lowerAgeLimit>
  <upperAgeLimit>60</upperAgeLimit>
  <pricingParameter>
    <sequence>1</sequence>
    <parameterCode>GENDER</parameterCode>
    <parameterValue>FEMALE</parameterValue>
  </pricingParameter>
  <modifierInformation>
    <sequence>1</sequence>
    <parameterCode>TOBUSAGE</parameterCode>
    <parameterValue>Y</parameterValue>
    <rate>50</rate>
  </modifierInformation>

```

```

</baseRate>
<baseRate>
  <sequence>10</sequence>
  <baseFee>270</baseFee>
  <lowerAgeLimit>41</lowerAgeLimit>
  <upperAgeLimit>60</upperAgeLimit>
  <pricingParameter>
    <sequence>1</sequence>
    <parameterCode>GENDER</parameterCode>
    <parameterValue>MALE</parameterValue>
  </pricingParameter>
  <modifierInformation>
    <sequence>1</sequence>
    <parameterCode>TOBUSAGE</parameterCode>
    <parameterValue>Y</parameterValue>
    <rate>60</rate>
  </modifierInformation>
</baseRate>
<baseRate>
  <sequence>11</sequence>
  <baseFee>300</baseFee>
  <lowerAgeLimit>61</lowerAgeLimit>
  <upperAgeLimit>65</upperAgeLimit>
  <pricingParameter>
    <sequence>1</sequence>
    <parameterCode>GENDER</parameterCode>
    <parameterValue>FEMALE</parameterValue>
  </pricingParameter>
  <modifierInformation>
    <sequence>1</sequence>
    <parameterCode>TOBUSAGE</parameterCode>
    <parameterValue>Y</parameterValue>
    <rate>60</rate>
  </modifierInformation>
</baseRate>
<baseRate>
  <sequence>12</sequence>
  <baseFee>300</baseFee>
  <lowerAgeLimit>61</lowerAgeLimit>
  <upperAgeLimit>65</upperAgeLimit>
  <pricingParameter>
    <sequence>1</sequence>
    <parameterCode>GENDER</parameterCode>
    <parameterValue>MALE</parameterValue>
  </pricingParameter>
  <modifierInformation>
    <sequence>1</sequence>
    <parameterCode>TOBUSAGE</parameterCode>
    <parameterValue>Y</parameterValue>
    <rate>70</rate>
  </modifierInformation>
</baseRate>
<baseRate>
  <sequence>13</sequence>
  <baseFee>350</baseFee>
  <lowerAgeLimit>66</lowerAgeLimit>
  <upperAgeLimit>199</upperAgeLimit>
  <pricingParameter>
    <sequence>1</sequence>
    <parameterCode>GENDER</parameterCode>
    <parameterValue>FEMALE</parameterValue>
  </pricingParameter>
  <modifierInformation>
    <sequence>1</sequence>

```

```

        <parameterCode>TOBUSAGE</parameterCode>
        <parameterValue>Y</parameterValue>
        <rate>70</rate>
      </modifierInformation>
    </baseRate>
    <baseRate>
      <sequence>14</sequence>
      <baseFee>350</baseFee>
      <lowerAgeLimit>66</lowerAgeLimit>
      <upperAgeLimit>199</upperAgeLimit>
      <pricingParameter>
        <sequence>1</sequence>
        <parameterCode>GENDER</parameterCode>
        <parameterValue>MALE</parameterValue>
      </pricingParameter>
      <modifierInformation>
        <sequence>1</sequence>
        <parameterCode>TOBUSAGE</parameterCode>
        <parameterValue>Y</parameterValue>
        <rate>80</rate>
      </modifierInformation>
    </baseRate>
  </pricingRuleData>
</customerStructureData>
</customerStructureMessage>
</schema>

```

## Sample Health Care Inbound Message for Membership

Using the below example, you can do the following:

- Create the persons who are neither parent customer nor bill group
- Create a membership where the person is the main subscriber
- Add persons in a membership

Person Name	Person Type	Policy	Policy Plan	Main Subscriber	Member Relationship Type
G, ALLEN	Person	AP234389	HMO_MED_SILVER_RET	Yes	SELF
G, JOHNSON	Person	AP234389	HMO_MED_SILVER_RET	No	SPOUSE
G, CLARK	Person	AP234389	HMO_MED_SILVER_RET	No	SON
G, NELSON	Person	AP234389	HMO_MED_SILVER_RET	No	SON
G, PARKER	Person	AP234389	HMO_MED_SILVER_RET	No	SON
G, RUSSEL	Person	AP234389	HMO_MED_SILVER_RET	No	SON
G, LINDA	Person	AP234389	HMO_MED_SILVER_RET	No	DAUGHTER

```

<schema>
  <bo>C1-HCInboundMessage</bo>
  <characteristics>
    <inboundMessageCharacteristic>
      <adhocCharacteristicValue></adhocCharacteristicValue>
      <characteristicType>C1-EXTBTCT</characteristicType>
      <effectiveDate>2019-01-01</effectiveDate>
      <characteristicValue>DATAEXT2</characteristicValue>
      <characteristicValueForeignKey1></characteristicValueForeignKey1>
      <characteristicValueFK2></characteristicValueFK2>
    </inboundMessageCharacteristic>
  </characteristics>
</schema>

```



```

        <characteristicValueFK3></characteristicValueFK3>
        <characteristicValueFk4></characteristicValueFk4>
        <characteristicValueFK5></characteristicValueFK5>
    </inboundMessageCharacteristic>
</characteristics>
<customerStructureMessage>
    <headerData>
        <messageType>C1-HEALTHCARE-INB-MSG-TYPE</messageType>
        <sourceSystem>SMALLPRIME</sourceSystem>
        <externalTransactionId>123445</externalTransactionId>
        <externalBatchId>433443</externalBatchId>
        <externalSourceId>656565</externalSourceId>
    </headerData>
    <customerStructureData>
        <personData>
            <sequence>1</sequence>
            <personType>P</personType>
            <personName>
                <sequence>1</sequence>
                <entityName>G, ALLEN</entityName>
                <nameType>PRIM</nameType>
            </personName>
            <identifiers>
                <idType>SSN</idType>
                <idValue>987-65-4323</idValue>
                <isPrimary>Y</isPrimary>
            </identifiers>
            <division>HC</division>
            <birthDate>1965-02-02</birthDate>
            <sinceDate>2019-01-01</sinceDate>
            <address>
                <addressEffDate>2019-01-01</addressEffDate>
                <addressType>MAIN</addressType>
                <mailingName>ALLEN</mailingName>
                <address1>Saturn Apartment</address1>
                <address2>Saturn Street</address2>
                <address3>River Side</address3>
                <address4></address4>
                <city>Buffalo</city>
                <state>NY</state>
                <zip>14201</zip>
                <country>USA</country>
            </address>
            <email>allen.g@example.com</email>
            <overrideMailingName1></overrideMailingName1>
            <overrideMailingName2></overrideMailingName2>
            <overrideMailingName3></overrideMailingName3>
            <phones>
                <phoneType>BUSN</phoneType>
                <phoneValue>716-555-0135</phoneValue>
            </phones>
            <relatedPersons>
                <idType></idType>
                <idValue></idValue>
                <personRelationshipType></personRelationshipType>
                <startDate></startDate>
                <endDate></endDate>
                <financialRelationshipSw></financialRelationshipSw>
                <parentOrChild></parentOrChild>
                <characteristics>
                    <characteristicsList>
                        <characteristicType></characteristicType>
                        <characteristicValue></characteristicValue>
                        <effectiveDate></effectiveDate>
                    </characteristicsList>
                </characteristics>
            </relatedPersons>
        </personData>
    </customerStructureData>
</customerStructureMessage>

```

```

        </characteristicsList>
    </characteristics>
</relatedPersons>
<characteristics>
    <characteristicsList>
        <characteristicType>PER_CAT</characteristicType>
        <characteristicValue>EMPLOYEE</characteristicValue>
        <effectiveDate>2019-01-01</effectiveDate>
    </characteristicsList>
</characteristics>
<memberData>
    <sequence>10</sequence>
    <startDate>2019-01-01</startDate>
    <endDate>2019-12-31</endDate>
    <memberId>1000410004</memberId>
    <memberRelationship>SELF</memberRelationship>
    <mainSubscriber>
        <idType>SSN</idType>
        <idValue>987-65-4323</idValue>
    </mainSubscriber>
    <policyNumber>AP234389</policyNumber>
    <sourceSystem>SMALLPRIME</sourceSystem>
    <planNumber>HMO_MED_SILVER_RET</planNumber>
    <characteristics>
        <characteristicsList>
            <characteristicType>BILLLEV1</characteristicType>
            <characteristicValue>RET</characteristicValue>
            <effectiveDate>2019-01-01</effectiveDate>
        </characteristicsList>
        <characteristicsList>
            <characteristicType>BILLLEV2</characteristicType>
            <characteristicValue>SEATTLE</characteristicValue>
            <effectiveDate>2019-01-01</effectiveDate>
        </characteristicsList>
        <characteristicsList>
            <characteristicType>BILLLEV3</characteristicType>
            <characteristicValue>MEDICAL</characteristicValue>
            <effectiveDate>2019-01-01</effectiveDate>
        </characteristicsList>
        <characteristicsList>
            <characteristicType>BILLLEV4</characteristicType>
            <characteristicValue>HMO</characteristicValue>
            <effectiveDate>2019-01-01</effectiveDate>
        </characteristicsList>
    </characteristics>
    <membershipPersonCharacteristic>
        <characteristicsList>
            <characteristicType>TOBUSAGE</characteristicType>
            <characteristicValue>N</characteristicValue>
            <effectiveDate>2019-01-01</effectiveDate>
        </characteristicsList>
        <characteristicsList>
            <characteristicType>C1-GENDR</characteristicType>
            <characteristicValue>FEMALE</characteristicValue>
            <effectiveDate>2019-01-01</effectiveDate>
        </characteristicsList>
    </membershipPersonCharacteristic>
    <billableChargeData>
        <sequence>1</sequence>
        <accountIdType>ACCT_NM</accountIdType>
        <accountIdValue>Medical Account</accountIdValue>
        <chargeType></chargeType>
        <startDate>2019-01-01</startDate>
        <endDate>2019-03-31</endDate>
    </billableChargeData>

```

```

<priceItemCode>MED_PREM_FEE</priceItemCode>
<description>Recurring Premium Fees</description>
<recurringMethod>BP</recurringMethod>
<billPeriod>HC</billPeriod>
<frequency></frequency>
<billAfterDt></billAfterDt>
<billableChargeLines>
  <descriptionOnBill>Premium Fees</
descriptionOnBill>
  <currencyCode>USD</currencyCode>
  <chargeAmount>100</chargeAmount>
  <showOnBillSw>true</showOnBillSw>
  <appearInSummarySw>false</appearInSummarySw>
  <distributionCode>HC</distributionCode>
</billableChargeLines>
<characteristics>
  <characteristicsList>
    <characteristicType></characteristicType>
    <characteristicValue></characteristicValue>
    <effectiveDate></effectiveDate>
  </characteristicsList>
</characteristics>
</billableChargeData>
<billableChargeData>
  <sequence>2</sequence>
  <accountIdType>ACCT_NM</accountIdType>
  <accountIdValue>Dental Account</accountIdValue>
  <chargeType></chargeType>
  <startDate>2019-01-01</startDate>
  <endDate>2019-12-31</endDate>
  <priceItemCode>DEN_PREM_FEE</priceItemCode>
  <description>Recurring Premium Fees</description>
  <recurringMethod>BP</recurringMethod>
  <billPeriod>HC</billPeriod>
  <frequency></frequency>
  <billAfterDt></billAfterDt>
  <billableChargeLines>
    <descriptionOnBill>Premium Fees</
descriptionOnBill>
    <currencyCode>USD</currencyCode>
    <chargeAmount>50</chargeAmount>
    <showOnBillSw>true</showOnBillSw>
    <appearInSummarySw>true</appearInSummarySw>
    <distributionCode>HC</distributionCode>
  </billableChargeLines>
  <characteristics>
    <characteristicsList>
      <characteristicType></characteristicType>
      <characteristicValue></characteristicValue>
      <effectiveDate></effectiveDate>
    </characteristicsList>
  </characteristics>
</billableChargeData>
<billableChargeData>
  <sequence>3</sequence>
  <accountIdType></accountIdType>
  <accountIdValue></accountIdValue>
  <chargeType></chargeType>
  <startDate>2019-01-01</startDate>
  <endDate>2019-12-31</endDate>
  <priceItemCode>MED_PREM_FEE</priceItemCode>
  <description>Recurring Premium Fees</description>
  <recurringMethod>BP</recurringMethod>
  <billPeriod>HC</billPeriod>

```

```

        <frequency></frequency>
        <billAfterDt></billAfterDt>
        <billableChargeLines>
            <descriptionOnBill>Premium Fees</
descriptionOnBill>
            <currencyCode>USD</currencyCode>
            <chargeAmount>100</chargeAmount>
            <showOnBillSw>true</showOnBillSw>
            <appearInSummarySw>true</appearInSummarySw>
            <distributionCode>HC</distributionCode>
        </billableChargeLines>
        <characteristics>
            <characteristicsList>
                <characteristicType></characteristicType>
                <characteristicValue></characteristicValue>
                <effectiveDate></effectiveDate>
            </characteristicsList>
        </characteristics>
    </billableChargeData>
</memberData>
</personData>
<personData>
    <sequence>2</sequence>
    <personType>P</personType>
    <personName>
        <sequence>1</sequence>
        <entityName>G, JOHNSON</entityName>
        <nameType>PRIM</nameType>
    </personName>
    <identifiers>
        <idType>SSN</idType>
        <idValue>987-65-4324</idValue>
        <isPrimary>Y</isPrimary>
    </identifiers>
    <division>HC</division>
    <birthDate>1964-03-03</birthDate>
    <sinceDate>2019-01-01</sinceDate>
    <address>
        <addressEffDate>2019-01-01</addressEffDate>
        <addressType>MAIN</addressType>
        <mailingName>JOHNSON</mailingName>
        <address1>Saturn Apartment</address1>
        <address2>Saturn Street</address2>
        <address3>River Side</address3>
        <address4></address4>
        <city>Buffalo</city>
        <state>NY</state>
        <zip>14201</zip>
        <country>USA</country>
    </address>
    <email>johnson.g@example.com</email>
    <overrideMailingName1></overrideMailingName1>
    <overrideMailingName2></overrideMailingName2>
    <overrideMailingName3></overrideMailingName3>
    <phones>
        <phoneType>BUSN</phoneType>
        <phoneValue>716-555-0122</phoneValue>
    </phones>
    <relatedPersons>
        <idType></idType>
        <idValue></idValue>
        <personRelationshipType></personRelationshipType>
        <startDate></startDate>
        <endDate></endDate>

```

```

    <financialRelationshipSw></financialRelationshipSw>
    <parentOrChild></parentOrChild>
    <characteristics>
      <characteristicsList>
        <characteristicType></characteristicType>
        <characteristicValue></characteristicValue>
        <effectiveDate></effectiveDate>
      </characteristicsList>
    </characteristics>
  </relatedPersons>
  <characteristics>
    <characteristicsList>
      <characteristicType></characteristicType>
      <characteristicValue></characteristicValue>
      <effectiveDate></effectiveDate>
    </characteristicsList>
  </characteristics>
  <memberData>
    <sequence>10</sequence>
    <startDate>2019-01-01</startDate>
    <endDate>2019-12-31</endDate>
    <memberId>1000410004</memberId>
    <memberRelationship>SPOUSE</memberRelationship>
    <mainSubscriber>
      <idType>SSN</idType>
      <idValue>987-65-4323</idValue>
    </mainSubscriber>
    <policyNumber>AP234389</policyNumber>
    <sourceSystem>SMALLPRIME</sourceSystem>
    <planNumber>HMO_MED_SILVER_RET</planNumber>
    <characteristics>
      <characteristicsList>
        <characteristicType></characteristicType>
        <characteristicValue></characteristicValue>
        <effectiveDate></effectiveDate>
      </characteristicsList>
    </characteristics>
    <membershipPersonCharacteristic>
      <characteristicsList>
        <characteristicType>TOBUSAGE</characteristicType>
        <characteristicValue>Y</characteristicValue>
        <effectiveDate>2019-01-01</effectiveDate>
      </characteristicsList>
      <characteristicsList>
        <characteristicType>C1-GENDR</characteristicType>
        <characteristicValue>MALE</characteristicValue>
        <effectiveDate>2019-01-01</effectiveDate>
      </characteristicsList>
    </membershipPersonCharacteristic>
  </memberData>
</personData>
<personData>
  <sequence>3</sequence>
  <personType>P</personType>
  <personName>
    <sequence>1</sequence>
    <entityName>G, CLARK</entityName>
    <nameType>PRIM</nameType>
  </personName>
  <identifiers>
    <idType>SSN</idType>
    <idValue>987-65-4325</idValue>
    <isPrimary>Y</isPrimary>
  </identifiers>

```

```

<division>HC</division>
<birthDate>2004-08-08</birthDate>
<sinceDate>2019-01-01</sinceDate>
<address>
  <addressEffDate>2019-01-01</addressEffDate>
  <addressType>MAIN</addressType>
  <mailingName>CLARK</mailingName>
  <address1>Saturn Apartment</address1>
  <address2>Saturn Street</address2>
  <address3>River Side</address3>
  <address4></address4>
  <city>Buffalo</city>
  <state>NY</state>
  <zip>14201</zip>
  <country>USA</country>
</address>
<email>clark.g@example.com</email>
<overrideMailingName1></overrideMailingName1>
<overrideMailingName2></overrideMailingName2>
<overrideMailingName3></overrideMailingName3>
<phones>
  <phoneType>BUSN</phoneType>
  <phoneValue>716-555-0109</phoneValue>
</phones>
<relatedPersons>
  <idType></idType>
  <idValue></idValue>
  <personRelationshipType></personRelationshipType>
  <startDate></startDate>
  <endDate></endDate>
  <financialRelationshipSw></financialRelationshipSw>
  <parentOrChild></parentOrChild>
  <characteristics>
    <characteristicsList>
      <characteristicType></characteristicType>
      <characteristicValue></characteristicValue>
      <effectiveDate></effectiveDate>
    </characteristicsList>
  </characteristics>
</relatedPersons>
<characteristics>
  <characteristicsList>
    <characteristicType></characteristicType>
    <characteristicValue></characteristicValue>
    <effectiveDate></effectiveDate>
  </characteristicsList>
</characteristics>
<memberData>
  <sequence>10</sequence>
  <startDate>2019-01-01</startDate>
  <endDate>2019-12-31</endDate>
  <memberId>1000410004</memberId>
  <memberRelationship>SON</memberRelationship>
  <mainSubscriber>
    <idType>SSN</idType>
    <idValue>987-65-4323</idValue>
  </mainSubscriber>
  <policyNumber>AP234389</policyNumber>
  <sourceSystem>SMALLPRIME</sourceSystem>
  <planNumber>HMO_MED_SILVER_RET</planNumber>
  <characteristics>
    <characteristicsList>
      <characteristicType></characteristicType>
      <characteristicValue></characteristicValue>
    </characteristicsList>
  </characteristics>

```

```

        <effectiveDate></effectiveDate>
      </characteristicsList>
    </characteristics>
    <membershipPersonCharacteristic>
      <characteristicsList>
        <characteristicType>TOBUSUSAGE</characteristicType>
        <characteristicValue>N</characteristicValue>
        <effectiveDate>2019-01-01</effectiveDate>
      </characteristicsList>
      <characteristicsList>
        <characteristicType>C1-GENDR</characteristicType>
        <characteristicValue>MALE</characteristicValue>
        <effectiveDate>2019-01-01</effectiveDate>
      </characteristicsList>
    </membershipPersonCharacteristic>
  </memberData>
</personData>
<personData>
  <sequence>4</sequence>
  <personType>P</personType>
  <personName>
    <sequence>1</sequence>
    <entityName>G, NELSON</entityName>
    <nameType>PRIM</nameType>
  </personName>
  <identifiers>
    <idType>SSN</idType>
    <idValue>987-65-4326</idValue>
    <isPrimary>Y</isPrimary>
  </identifiers>
  <division>HC</division>
  <birthDate>2002-07-07</birthDate>
  <sinceDate>2019-01-01</sinceDate>
  <address>
    <addressEffDate>2019-01-01</addressEffDate>
    <addressType>MAIN</addressType>
    <mailingName>NELSON</mailingName>
    <address1>Saturn Apartment</address1>
    <address2>Saturn Street</address2>
    <address3>River Side</address3>
    <address4></address4>
    <city>Buffalo</city>
    <state>NY</state>
    <zip>14201</zip>
    <country>USA</country>
  </address>
  <email>neilson.g@example.com</email>
  <overrideMailingName1></overrideMailingName1>
  <overrideMailingName2></overrideMailingName2>
  <overrideMailingName3></overrideMailingName3>
  <phones>
    <phoneType>BUSN</phoneType>
    <phoneValue>716-555-0108</phoneValue>
  </phones>
  <relatedPersons>
    <idType></idType>
    <idValue></idValue>
    <personRelationshipType></personRelationshipType>
    <startDate></startDate>
    <endDate></endDate>
    <financialRelationshipSw></financialRelationshipSw>
    <parentOrChild></parentOrChild>
    <characteristics>
      <characteristicsList>

```

```

        <characteristicType></characteristicType>
        <characteristicValue></characteristicValue>
        <effectiveDate></effectiveDate>
    </characteristicsList>
</characteristics>
</relatedPersons>
<characteristics>
    <characteristicsList>
        <characteristicType></characteristicType>
        <characteristicValue></characteristicValue>
        <effectiveDate></effectiveDate>
    </characteristicsList>
</characteristics>
<memberData>
    <sequence>10</sequence>
    <startDate>2019-01-01</startDate>
    <endDate>2019-12-31</endDate>
    <memberId>1000410004</memberId>
    <memberRelationship>SON</memberRelationship>
    <mainSubscriber>
        <idType>SSN</idType>
        <idValue>987-65-4323</idValue>
    </mainSubscriber>
    <policyNumber>AP234389</policyNumber>
    <sourceSystem>SMALLPRIME</sourceSystem>
    <planNumber>HMO_MED_SILVER_RET</planNumber>
    <characteristics>
        <characteristicsList>
            <characteristicType></characteristicType>
            <characteristicValue></characteristicValue>
            <effectiveDate></effectiveDate>
        </characteristicsList>
    </characteristics>
    <membershipPersonCharacteristic>
        <characteristicsList>
            <characteristicType>TOBUSAGE</characteristicType>
            <characteristicValue>N</characteristicValue>
            <effectiveDate>2019-01-01</effectiveDate>
        </characteristicsList>
        <characteristicsList>
            <characteristicType>C1-GENDR</characteristicType>
            <characteristicValue>MALE</characteristicValue>
            <effectiveDate>2019-01-01</effectiveDate>
        </characteristicsList>
    </membershipPersonCharacteristic>
</memberData>
</personData>
<personData>
    <sequence>5</sequence>
    <personType>P</personType>
    <personName>
        <sequence>1</sequence>
        <entityName>G, PARKER</entityName>
        <nameType>PRIM</nameType>
    </personName>
    <identifiers>
        <idType>SSN</idType>
        <idValue>987-65-4327</idValue>
        <isPrimary>Y</isPrimary>
    </identifiers>
    <division>HC</division>
    <birthDate>1995-06-06</birthDate>
    <sinceDate>2019-01-01</sinceDate>
    <address>

```



```

<addressEffDate>2019-01-01</addressEffDate>
<addressType>MAIN</addressType>
<mailingName>PARKER</mailingName>
<address1>Saturn Apartment</address1>
<address2>Saturn Street</address2>
<address3>River Side</address3>
<address4></address4>
<city>Buffalo</city>
<state>NY</state>
<zip>14201</zip>
<country>USA</country>
</address>
<email>parker.g@example.com</email>
<overrideMailingName1></overrideMailingName1>
<overrideMailingName2></overrideMailingName2>
<overrideMailingName3></overrideMailingName3>
<phones>
  <phoneType>BUSN</phoneType>
  <phoneValue>716-555-0107</phoneValue>
</phones>
<relatedPersons>
  <idType></idType>
  <idValue></idValue>
  <personRelationshipType></personRelationshipType>
  <startDate></startDate>
  <endDate></endDate>
  <financialRelationshipSw></financialRelationshipSw>
  <parentOrChild></parentOrChild>
  <characteristics>
    <characteristicsList>
      <characteristicType></characteristicType>
      <characteristicValue></characteristicValue>
      <effectiveDate></effectiveDate>
    </characteristicsList>
  </characteristics>
</relatedPersons>
<characteristics>
  <characteristicsList>
    <characteristicType></characteristicType>
    <characteristicValue></characteristicValue>
    <effectiveDate></effectiveDate>
  </characteristicsList>
</characteristics>
<memberData>
  <sequence>10</sequence>
  <startDate>2019-01-01</startDate>
  <endDate>2019-12-31</endDate>
  <memberId>1000410004</memberId>
  <memberRelationship>SON</memberRelationship>
  <mainSubscriber>
    <idType>SSN</idType>
    <idValue>987-65-4323</idValue>
  </mainSubscriber>
  <policyNumber>AP234389</policyNumber>
  <sourceSystem>SMALLPRIME</sourceSystem>
  <planNumber>HMO_MED_SILVER_RET</planNumber>
  <characteristics>
    <characteristicsList>
      <characteristicType></characteristicType>
      <characteristicValue></characteristicValue>
      <effectiveDate></effectiveDate>
    </characteristicsList>
  </characteristics>
</membershipPersonCharacteristic>

```

```

        <characteristicsList>
            <characteristicType>TOBUSAGE</characteristicType>
            <characteristicValue>N</characteristicValue>
            <effectiveDate>2019-01-01</effectiveDate>
        </characteristicsList>
        <characteristicsList>
            <characteristicType>C1-GENDR</characteristicType>
            <characteristicValue>MALE</characteristicValue>
            <effectiveDate>2019-01-01</effectiveDate>
        </characteristicsList>
    </membershipPersonCharacteristic>
</memberData>
</personData>
<personData>
    <sequence>6</sequence>
    <personType>P</personType>
    <personName>
        <sequence>1</sequence>
        <entityName>G, RUSSEL</entityName>
        <nameType>PRIM</nameType>
    </personName>
    <identifiers>
        <idType>SSN</idType>
        <idValue>987-65-4328</idValue>
        <isPrimary>Y</isPrimary>
    </identifiers>
    <division>HC</division>
    <birthDate>2000-04-04</birthDate>
    <sinceDate>2019-01-01</sinceDate>
    <address>
        <addressEffDate>2019-01-01</addressEffDate>
        <addressType>MAIN</addressType>
        <mailingName>RUSSEL</mailingName>
        <address1>Saturn Apartment</address1>
        <address2>Saturn Street</address2>
        <address3>River Side</address3>
        <address4></address4>
        <city>Buffalo</city>
        <state>NY</state>
        <zip>14201</zip>
        <country>USA</country>
    </address>
    <email>russel.g@example.com</email>
    <overrideMailingName1></overrideMailingName1>
    <overrideMailingName2></overrideMailingName2>
    <overrideMailingName3></overrideMailingName3>
    <phones>
        <phoneType>BUSN</phoneType>
        <phoneValue>716-555-0106</phoneValue>
    </phones>
    <relatedPersons>
        <idType></idType>
        <idValue></idValue>
        <personRelationshipType></personRelationshipType>
        <startDate></startDate>
        <endDate></endDate>
        <financialRelationshipSw></financialRelationshipSw>
        <parentOrChild></parentOrChild>
        <characteristics>
            <characteristicsList>
                <characteristicType></characteristicType>
                <characteristicValue></characteristicValue>
                <effectiveDate></effectiveDate>
            </characteristicsList>
        </characteristics>
    </relatedPersons>

```

```

        </characteristics>
    </relatedPersons>
    <characteristics>
        <characteristicsList>
            <characteristicType></characteristicType>
            <characteristicValue></characteristicValue>
            <effectiveDate></effectiveDate>
        </characteristicsList>
    </characteristics>
    <memberData>
        <sequence>10</sequence>
        <startDate>2019-01-01</startDate>
        <endDate>2019-12-31</endDate>
        <memberId>1000410004</memberId>
        <memberRelationship>SON</memberRelationship>
        <mainSubscriber>
            <idType>SSN</idType>
            <idValue>987-65-4323</idValue>
        </mainSubscriber>
        <policyNumber>AP234389</policyNumber>
        <sourceSystem>SMALLPRIME</sourceSystem>
        <planNumber>HMO_MED_SILVER_RET</planNumber>
        <characteristics>
            <characteristicsList>
                <characteristicType></characteristicType>
                <characteristicValue></characteristicValue>
                <effectiveDate></effectiveDate>
            </characteristicsList>
        </characteristics>
        <membershipPersonCharacteristic>
            <characteristicsList>
                <characteristicType>TOBUSAGE</characteristicType>
                <characteristicValue>N</characteristicValue>
                <effectiveDate>2019-01-01</effectiveDate>
            </characteristicsList>
            <characteristicsList>
                <characteristicType>C1-GENDR</characteristicType>
                <characteristicValue>MALE</characteristicValue>
                <effectiveDate>2019-01-01</effectiveDate>
            </characteristicsList>
        </membershipPersonCharacteristic>
    </memberData>
</personData>
<personData>
    <sequence>7</sequence>
    <personType>P</personType>
    <personName>
        <sequence>1</sequence>
        <entityName>G, LINDA</entityName>
        <nameType>PRIM</nameType>
    </personName>
    <identifiers>
        <idType>SSN</idType>
        <idValue>987-65-4329</idValue>
        <isPrimary>Y</isPrimary>
    </identifiers>
    <division>HC</division>
    <birthDate>1998-05-05</birthDate>
    <sinceDate>2019-01-01</sinceDate>
    <address>
        <addressEffDate>2019-01-01</addressEffDate>
        <addressType>MAIN</addressType>
        <mailingName>LINDA</mailingName>
        <address1>Saturn Apartment</address1>
    </address>
</personData>

```

```

    <address2>Saturn Street</address2>
    <address3>River Side</address3>
    <address4></address4>
    <city>Buffalo</city>
    <state>NY</state>
    <zip>14201</zip>
    <country>USA</country>
  </address>
  <email>linda.g@example.com</email>
  <overrideMailingName1></overrideMailingName1>
  <overrideMailingName2></overrideMailingName2>
  <overrideMailingName3></overrideMailingName3>
  <phones>
    <phoneType>BUSN</phoneType>
    <phoneValue>716-555-0103</phoneValue>
  </phones>
  <relatedPersons>
    <idType></idType>
    <idValue></idValue>
    <personRelationshipType></personRelationshipType>
    <startDate></startDate>
    <endDate></endDate>
    <financialRelationshipSw></financialRelationshipSw>
    <parentOrChild></parentOrChild>
    <characteristics>
      <characteristicsList>
        <characteristicType></characteristicType>
        <characteristicValue></characteristicValue>
        <effectiveDate></effectiveDate>
      </characteristicsList>
    </characteristics>
  </relatedPersons>
  <characteristics>
    <characteristicsList>
      <characteristicType></characteristicType>
      <characteristicValue></characteristicValue>
      <effectiveDate></effectiveDate>
    </characteristicsList>
  </characteristics>
  <memberData>
    <sequence>10</sequence>
    <startDate>2019-01-01</startDate>
    <endDate>2019-12-31</endDate>
    <memberId>1000410004</memberId>
    <memberRelationship>DAUGHTER</memberRelationship>
    <mainSubscriber>
      <idType>SSN</idType>
      <idValue>987-65-4323</idValue>
    </mainSubscriber>
    <policyNumber>AP234389</policyNumber>
    <sourceSystem>SMALLPRIME</sourceSystem>
    <planNumber>HMO_MED_SILVER_RET</planNumber>
    <characteristics>
      <characteristicsList>
        <characteristicType></characteristicType>
        <characteristicValue></characteristicValue>
        <effectiveDate></effectiveDate>
      </characteristicsList>
    </characteristics>
    <membershipPersonCharacteristic>
      <characteristicsList>
        <characteristicType>TOBUSAGE</characteristicType>
        <characteristicValue>N</characteristicValue>
        <effectiveDate>2019-02-05</effectiveDate>
      </characteristicsList>
    </membershipPersonCharacteristic>
  </memberData>

```

```

        </characteristicsList>
        <characteristicsList>
            <characteristicType>C1-GENDR</characteristicType>
            <characteristicValue>FEMALE</characteristicValue>
            <effectiveDate>2019-02-05</effectiveDate>
        </characteristicsList>
        </membershipPersonCharacteristic>
    </memberData>
</personData>
</customerStructureData>
</customerStructureMessage>
</schema>

```

## Inbound Message Type

Oracle Revenue Management and Billing allows you to define an inbound message type using which you can create an inbound message through an inbound web service. The following table describes the significance of the respective inbound message type:

Inbound Message Type	Helps the system to determine...
Customer Inbound Message Type	<ul style="list-style-type: none"> <li>• <b>Inbound Message Business Object</b> - The business object using which the inbound message should be created in the system.</li> <li>• <b>Person Business Object</b> - The business object using which a person should be created when the customer inbound message is processed.</li> <li>• <b>Account Business Object</b> - The business object using which an account should be created when the customer inbound message is processed.</li> <li>• <b>Hold Request Business Object</b> - The business object using which the hold request should be created when the <b>Invoice Hold Reason</b> characteristic is defined for an account in the customer inbound message.</li> <li>• <b>Status on Policy Termination</b> - The status to which the policy should be transitioned when the policy termination request is processed through the customer inbound message.</li> <li>• <b>Status on Policy Reinstatement</b> - The status to which the policy should be transitioned when the policy reinstatement request is processed through the customer inbound message.</li> <li>• <b>Status on Policy Renewal</b> - The status to which the policy should be transitioned when the policy renewal request is processed through the customer inbound message.</li> </ul>
Membership Inbound Message Type	<ul style="list-style-type: none"> <li>• <b>Inbound Message Business Object</b> - The business object using which the inbound message should be created in the system.</li> </ul>



Inbound Message Type	Helps the system to determine...
ASO Customer Inbound Message Type	<ul style="list-style-type: none"> <li>• <b>Inbound Message Business Object</b> - The business object using which the inbound message should be created in the system.</li> <li>• <b>Person Business Object</b> - The business object using which a person should be created when the ASO customer inbound message is processed.</li> <li>• <b>Account Business Object</b> - The business object using which an account should be created when the ASO customer inbound message is processed.</li> <li>• <b>Policy Type</b> - The policy type using which a policy should be created when the ASO customer inbound message is processed.</li> <li>• <b>Policy Plan Business Object</b> - The business object using which a policy plan should be created when the ASO customer inbound message is processed.</li> </ul>
Health Care Inbound Message Type	<ul style="list-style-type: none"> <li>• <b>Inbound Message Business Object</b> - The business object using which the inbound message should be created in the system.</li> <li>• <b>Customer Registration Type</b> - The customer registration type using which the customer registration object should be created through a health care inbound message.</li> </ul>

The **Inbound Message Type** screen allows you to define, edit, copy, and delete an inbound message type. It contains the following zones:

- [Inbound Message Type List](#) on page 1982
- [Inbound Message Type](#) on page 1983

## Inbound Message Type List

The **Inbound Message Type List** zone lists the inbound message types that are already defined in the system. It contains the following columns:

Column Name	Column Description
Inbound Message Type	Displays the inbound message type.
Description	Displays the description of the inbound message type.
Edit	On clicking the <b>Edit</b> (  ) icon, the <b>Inbound Message Type</b> screen appears where you can edit the details of the inbound message type.
Duplicate	On clicking the <b>Duplicate</b> (  ) icon, the <b>Inbound Message Type</b> screen appears where you can define a new inbound message type using an existing inbound message type.
Delete	On clicking the <b>Delete</b> (  ) icon, you can delete the inbound message type.  <b>Note:</b> You can delete an inbound message type only when an inbound message is not created using the inbound message type.

On clicking the **Broadcast** () icon corresponding to an inbound message type, the **Inbound Message Type** zone appears with the details of the respective inbound message type.

### Related Topics

For more information on...	See...
How to edit an inbound message type	<a href="#">Editing an Inbound Message Type</a> on page 1992
How to copy an inbound message type	<a href="#">Copying an Inbound Message Type</a> on page 1997
How to delete an inbound message type	<a href="#">Deleting an Inbound Message Type</a> on page 2001
How to view the details of an inbound message type	<a href="#">Viewing the Inbound Message Type Details</a> on page 1986

## Inbound Message Type

The **Inbound Message Type** zone displays the details of the inbound message type. It contains the following sections:

- **Main** – Displays basic information about the inbound message type. It contains the following fields:

Field Name	Field Description
Inbound Message Type	Displays the inbound message type.
Customer Registration Type	<p>Indicates the customer registration type using which the customer registration object is created through a health care inbound message.</p> <p><b>Note:</b> It has a link. On clicking the link, the <b>Customer Registration Type</b> screen appears where you can view the details of the respective customer registration type. This field appears only when you are viewing the details of an inbound message type which is created using the <b>C1-HCInboundMsgType</b> business object.</p>
Person Business Object	<p>Indicates the business object using which a person is created when the customer or ASO customer inbound message is processed. In addition, a context menu appears corresponding to this field which helps in navigating to other screens in the application.</p> <p><b>Note:</b> It has a link. On clicking the link, the <b>Business Object</b> screen appears where you can view the details of the respective business object. This field appears only when you are viewing the details of an inbound message type which is created using the <b>C1-CustomerInboundMessageType</b> or <b>C1-ASOCustomerInboundMsgType</b> business object.</p>
Account Business Object	<p>Indicates the business object using which an account is created when the customer or ASO customer inbound message is processed. In addition, a context menu appears corresponding to this field which helps in navigating to other screens in the application.</p> <p><b>Note:</b> It has a link. On clicking the link, the <b>Business Object</b> screen appears where you can view the details of the respective business object. This field appears only when you are viewing the details of an inbound message type which is created using the <b>C1-CustomerInboundMessageType</b> or <b>C1-ASOCustomerInboundMsgType</b> business object.</p>

Field Name	Field Description
Policy Type	<p>Indicates the policy type using which a policy is created when the ASO customer inbound message is processed.</p> <p><b>Note:</b></p> <p>It has a link. On clicking the link, the <b>Policy Type</b> screen appears where you can view the details of the respective policy type.</p> <p>This field appears only when you are viewing the details of an inbound message type which is created using the <b>C1-ASOCustomerInboundMsgType</b> business object.</p>
Policy Plan Business Object	<p>Indicates the business object using which a policy plan is created when the ASO customer inbound message is processed. In addition, a context menu appears corresponding to this field which helps in navigating to other screens in the application.</p> <p><b>Note:</b></p> <p>It has a link. On clicking the link, the <b>Business Object</b> screen appears where you can view the details of the respective business object.</p> <p>This field appears only when you are viewing the details of an inbound message type which is created using the <b>C1-ASOCustomerInboundMsgType</b> business object.</p>
Hold Request Business Object	<p>Indicates the business object using which a hold request is created for an account when the customer inbound message is processed. In addition, a context menu appears corresponding to this field which helps in navigating to other screens in the application.</p> <p><b>Note:</b></p> <p>It has a link. On clicking the link, the <b>Business Object</b> screen appears where you can view the details of the respective business object.</p> <p>This field appears only when you are viewing the details of an inbound message type which is created using the <b>C1-CustomerInboundMessageType</b> business object.</p>
Status on Policy Termination	<p>Indicates the status to which the policy is transitioned when the policy termination request is processed through the customer inbound message.</p> <p><b>Note:</b> This field appears only when you are viewing the details of an inbound message type which is created using the <b>C1-CustomerInboundMessageType</b> business object.</p>
Status on Policy Reinstatement	<p>Indicates the status to which the policy is transitioned when the policy reinstatement request is processed through the customer inbound message.</p> <p><b>Note:</b> This field appears only when you are viewing the details of an inbound message type which is created using the <b>C1-CustomerInboundMessageType</b> business object.</p>



Field Name	Field Description
Status on Policy Renewal	Indicates the status to which the policy is transitioned when the policy renewal request is processed through the customer inbound message.  <b>Note:</b> This field appears only when you are viewing the details of an inbound message type which is created using the <b>C1-CustomerInboundMessageType</b> business object.
Inbound Message Business Object	Indicates the business object using which the inbound message is created. In addition, a context menu appears corresponding to this field which helps in navigating to other screens in the application.  <b>Note:</b> It has a link. On clicking the link, the <b>Business Object</b> screen appears where you can view the details of the respective business object.
Description	Displays the description of the inbound message type.
Status	Indicates the status of the inbound message type. The valid values are: <ul style="list-style-type: none"> <li>Active</li> <li>Inactive</li> </ul>
Detailed Description	Displays additional information about the inbound message type.

- **Characteristics** – Lists the characteristics defined for the inbound message type. It contains the following columns:

Column Name	Column Description
Characteristic Type	Indicates the characteristic type.
Characteristic Value	Displays the value of the characteristic type.

- **Record Actions** – This section contains the following buttons:

Button Name	Button Description
Edit	Used to edit the details of the inbound message type.
Delete	Used to delete the inbound message type.  <b>Note:</b> You can delete an inbound message type only when an inbound message is not created using the inbound message type.
Duplicate	Used to create a new inbound message type using an existing inbound message type.

- **Record Information** – This section contains the following field:

Field Name	Field Description
Business Object	Indicates the business object using which the inbound message type is created. In addition, a context menu appears corresponding to this field which helps in navigating to other screens in the application.  <b>Note:</b> It has a link. On clicking the link, the <b>Business Object</b> screen appears where you can view the details of the respective business object.

By default, the **Inbound Message Type** zone does not appear in the **Inbound Message Type** screen. It appears only when you click the **Broadcast**  icon corresponding to an inbound message type in the **Inbound Message Type List** zone.

### **Related Topics**

<b>For more information on...</b>	<b>See...</b>
How to edit an inbound message type	<a href="#">Editing an Inbound Message Type</a> on page 1992
How to copy an inbound message type	<a href="#">Copying an Inbound Message Type</a> on page 1997
How to delete an inbound message type	<a href="#">Deleting an Inbound Message Type</a> on page 2001
How to view the details of an inbound message type	<a href="#">Viewing the Inbound Message Type Details</a> on page 1986

## **Viewing the Inbound Message Type Details**

### **Procedure**

To view the details of an inbound message type:

1. Click the **Admin** link in the **Application** toolbar.  
A list appears.
2. From the **Admin** menu, select **I** and then click **Inbound Message Type**.  
A sub-menu appears.
3. Click the **Search** option from the **Inbound Message Type** sub-menu.  
The **Inbound Message Type** screen appears.
4. In the **Inbound Message Type List** zone, click the **Broadcast**  icon corresponding to the inbound message type whose details you want to view.  
The **Inbound Message Type** zone appears.
5. View the details of the inbound message type in the **Inbound Message Type** zone.

### **Related Topics**

<b>For more information on...</b>	<b>See...</b>
<b>Inbound Message Type</b> screen	<a href="#">Inbound Message Type</a> on page 1981
<b>Inbound Message Type List</b> zone	<a href="#">Inbound Message Type List</a> on page 1982
<b>Inbound Message Type</b> zone	<a href="#">Inbound Message Type</a> on page 1983

## **Defining an Inbound Message Type**

### **Prerequisites**

The following table lists the prerequisites for defining various inbound message types:

If you want to define a..	Then, you should have...
Customer Inbound Message Type	<ul style="list-style-type: none"> <li>• Customer inbound message type business objects defined in the application</li> <li>• Customer inbound message business objects defined in the application</li> <li>• Person, account, and hold request business objects defined in the application</li> <li>• Status defined for the <b>C1-POLICY</b> business object to which a policy must be transitioned on policy termination</li> <li>• Status defined for the <b>C1-POLICY</b> business object to which a policy must be transitioned on policy renewal</li> <li>• Status defined for the <b>C1-POLICY</b> business object to which a policy must be transitioned on policy reinstatement</li> </ul>
Membership Inbound Message Type	<ul style="list-style-type: none"> <li>• Membership inbound message type business objects defined in the application</li> <li>• Membership inbound message business objects defined in the application</li> </ul>
ASO Customer Inbound Message Type	<ul style="list-style-type: none"> <li>• ASO customer inbound message type business objects defined in the application</li> <li>• ASO customer inbound message business objects defined in the application</li> <li>• Person, account, and policy plan business objects defined in the application</li> <li>• Policy types defined in the application</li> </ul>
Health Care Inbound Message Type	<ul style="list-style-type: none"> <li>• Health care inbound message type business objects defined in the application</li> <li>• Health care inbound message business objects defined in the application</li> <li>• Customer registration types defined in the application</li> </ul>

### **Procedure**

To define an inbound message type:

1. Click the **Admin** link in the **Application** toolbar.  
A list appears.
2. From the **Admin** menu, select **I** and then click **Inbound Message Type**.  
A sub-menu appears.
3. Click the **Add** option from the **Inbound Message Type** sub-menu.  
The **Select Business Object** screen appears. It contains the following field:

Field Name	Field Description	Mandatory (Yes or No)										
Inbound Message Type Business Object	Used to indicate the business object using which you want to create the inbound message type. The following table lists the business objects using which you can create the respective inbound message type: <table border="1" data-bbox="565 390 1252 768"> <thead> <tr> <th>Inbound Message Type</th> <th>Business Object</th> </tr> </thead> <tbody> <tr> <td>Customer Inbound Message Type</td> <td>C1-CustomerInboundMessageType</td> </tr> <tr> <td>Membership Inbound Message Type</td> <td>C1-MemberInboundMessageType</td> </tr> <tr> <td>ASO Customer Inbound Message Type</td> <td>C1-ASOCustomerInboundMsgType</td> </tr> <tr> <td>Health Care Inbound Message Type</td> <td>C1-HCInboundMsgType</td> </tr> </tbody> </table>	Inbound Message Type	Business Object	Customer Inbound Message Type	C1-CustomerInboundMessageType	Membership Inbound Message Type	C1-MemberInboundMessageType	ASO Customer Inbound Message Type	C1-ASOCustomerInboundMsgType	Health Care Inbound Message Type	C1-HCInboundMsgType	Yes
Inbound Message Type	Business Object											
Customer Inbound Message Type	C1-CustomerInboundMessageType											
Membership Inbound Message Type	C1-MemberInboundMessageType											
ASO Customer Inbound Message Type	C1-ASOCustomerInboundMsgType											
Health Care Inbound Message Type	C1-HCInboundMsgType											

**Tip:** Alternatively, you can access this screen by clicking the **Add** button in the **Page Title** area of the **Inbound Message Type** screen.

- Select the **ASO Customer Inbound Message Type**, **Customer Inbound Message Type**, **Health Care Inbound Message Type**, or **Membership Inbound Message Type** business object to create the respective inbound message type.
- Click **OK**.

The **Inbound Message Type** screen appears. It contains the following sections:

- Main** – Used to specify basic details about the inbound message type.
- Characteristics** – Used to define characteristics for the inbound message type.

The **Main** section contains the following fields:

Field Name	Field Description	Mandatory (Yes or No)
Inbound Message Type	Used to specify the inbound message type.	Yes
Business Object	Indicates the business object using which you are defining the inbound message type.	Not applicable

Field Name	Field Description	Mandatory (Yes or No)
Customer Registration Type	<p>Used to indicate the customer registration type using which you want to create the customer registration object through a health care inbound message.</p> <p><b>Note:</b> This field appears only when you are defining an inbound message type using the <b>C1-HCInboundMsgType</b> business object.</p> <p>While creating a health care inbound message type for the fully-insured health care business, you must use a customer registration type where the <b>Approval Required</b>, <b>Final Approval Required</b>, and <b>Manual Billing Hierarchy and Pricing</b> options are not selected. However, while creating a health care inbound message type for the self-funded health care business, you must use a customer registration type where the <b>Final Approval Required</b> and <b>Manual Billing Hierarchy and Pricing</b> options are selected, but the <b>Approval Required</b> option is not selected.</p>	Yes
Person Business Object	<p>Used to indicate the business object using which you want to create a person when the customer or ASO customer inbound message is processed.</p> <p><b>Note:</b> This field appears only when you are defining an inbound message type using the <b>C1-CustomerInboundMessageType</b> or <b>C1-ASOCustomerInboundMsgType</b> business object.</p>	Yes
Account Business Object	<p>Used to indicate the business object using which you want to create an account when the customer or ASO customer inbound message is processed.</p> <p><b>Note:</b> This field appears only when you are defining an inbound message type using the <b>C1-CustomerInboundMessageType</b> or <b>C1-ASOCustomerInboundMsgType</b> business object.</p>	Yes
Policy Type	<p>Used to indicate the policy type using which you want to create a policy when the ASO customer inbound message is processed.</p> <p><b>Note:</b> This field appears only when you are defining an inbound message type using the <b>C1-ASOCustomerInboundMsgType</b> business object.</p>	Yes

Field Name	Field Description	Mandatory (Yes or No)
Policy Plan Business Object	<p>Used to indicate the business object using which you want to create a policy plan when the ASO customer inbound message is processed.</p> <p><b>Note:</b> This field appears only when you are defining an inbound message type using the <b>C1-ASOCustomerInboundMsgType</b> business object.</p>	Yes
Hold Request Business Object	<p>Used to indicate the business object using which you want to create a hold request for an account when the customer inbound message is processed.</p> <p><b>Note:</b> This field appears only when you are defining an inbound message type using the <b>C1-CustomerInboundMessageType</b> business object.</p>	Yes
Status on Policy Termination	<p>Used to indicate the status to which the policy must be transitioned when the policy termination request is processed through the customer inbound message.</p> <p><b>Note:</b> This field appears only when you are defining an inbound message type using the <b>C1-CustomerInboundMessageType</b> business object. You must specify a status which is already defined in the lifecycle of the <b>C1-POLICY</b> business object.</p>	Yes
Status on Policy Reinstatement	<p>Used to indicate the status to which the policy must be transitioned when the policy reinstatement request is processed through the customer inbound message.</p> <p><b>Note:</b> This field appears only when you are defining an inbound message type using the <b>C1-CustomerInboundMessageType</b> business object. You must specify a status which is already defined in the lifecycle of the <b>C1-POLICY</b> business object.</p>	Yes

Field Name	Field Description	Mandatory (Yes or No)
Status on Policy Renewal	Used to indicate the status to which the policy must be transitioned when the policy renewal request is processed through the customer inbound message.  <b>Note:</b> This field appears only when you are defining an inbound message type using the <b>C1-CustomerInboundMessageType</b> business object.  You must specify a status which is already defined in the lifecycle of the <b>C1-POLICY</b> business object.	Yes
Inbound Message Business Object	Used to indicate the business object using which you want to create the respective inbound message.	Yes
Description	Used to specify the description for the inbound message type.	Yes
Status	Used to indicate the status of the inbound message type. The valid values are: <ul style="list-style-type: none"> <li>Active</li> <li>Inactive</li> </ul>	Yes
Detailed Description	Used to specify additional information about the inbound message type.	No

- Enter the required details in the **Main** section.
- Define characteristics for the inbound message type, if required.
- Click **Save**.

The inbound message type is defined.

### **Related Topics**

For more information on...	See...
<b>Inbound Message Type</b> screen	<a href="#">Inbound Message Type</a> on page 1981
How to define a characteristic for an inbound message type	<a href="#">Defining a Characteristic for an Inbound Message Type</a> on page 1991

## **Defining a Characteristic for an Inbound Message Type**

### **Prerequisites**

To define a characteristic for an inbound message type, you should have:

- Characteristic types defined in the application (where the characteristic entity is set to **Inbound Message Type**)

### **Procedure**

To define a characteristic for an inbound message type:

1. Ensure that the **Characteristics** section is expanded when you are defining, editing, or copying an inbound message type.

The **Characteristics** section contains the following fields in a grid:

Field Name	Field Description	Mandatory (Yes or No)
Characteristic Type	Used to indicate the characteristic type.  <b>Note:</b> The list includes only those characteristic types where the characteristic entity is set to <b>Inbound Message Type</b> .	Yes (Conditional)  <b>Note:</b> This field is required while defining a characteristic for the inbound message type.
Characteristic Value	Used to specify the value for the characteristic type.  <b>Note:</b> If you select a predefined characteristic type, the <b>Search</b>  icon appears corresponding to the <b>Characteristic Value</b> field. On clicking the <b>Search</b> icon, the <b>Predefined Characteristic Search</b> window appears. On specifying the value for a predefined characteristic type, the description of the characteristic value appears corresponding to the <b>Characteristic Value</b> field.	Yes (Conditional)  <b>Note:</b> This field is required while defining a characteristic for the inbound message type.

2. Enter the required details in the **Characteristics** section.
3. If you want to define more than one characteristic for the inbound message type, click the **Add**  icon and then repeat step 2.

**Note:** However, if you want to remove a characteristic from the inbound message type, click the **Delete**  icon corresponding to the characteristic.

### **Related Topics**

For more information on...	See...
How to define an inbound message type	<a href="#">Defining an Inbound Message Type</a> on page 1986
How to edit an inbound message type	<a href="#">Editing an Inbound Message Type</a> on page 1992
How to copy an inbound message type	<a href="#">Copying an Inbound Message Type</a> on page 1997

## **Editing an Inbound Message Type**

### **Prerequisites**

The following table lists the prerequisites for editing various inbound message types:



If you want to define a..	Then, you should have...
Customer Inbound Message Type	<ul style="list-style-type: none"> <li>• Customer inbound message business objects defined in the application</li> <li>• Person, account, and hold request business objects defined in the application</li> <li>• Status defined for the <b>C1-POLICY</b> business object to which a policy must be transitioned on policy termination</li> <li>• Status defined for the <b>C1-POLICY</b> business object to which a policy must be transitioned on policy renewal</li> <li>• Status defined for the <b>C1-POLICY</b> business object to which a policy must be transitioned on policy reinstatement</li> </ul>
Membership Inbound Message Type	<ul style="list-style-type: none"> <li>• Membership inbound message business objects defined in the application</li> </ul>
ASO Customer Inbound Message Type	<ul style="list-style-type: none"> <li>• ASO customer inbound message business objects defined in the application</li> <li>• Person, account, and policy plan business objects defined in the application</li> <li>• Policy types defined in the application</li> </ul>
Health Care Inbound Message Type	<ul style="list-style-type: none"> <li>• Health care inbound message business objects defined in the application</li> <li>• Customer registration types defined in the application</li> </ul>

### **Procedure**

To edit an inbound message type:

1. Click the **Admin** link in the **Application** toolbar.  
A list appears.
2. From the **Admin** menu, select **I** and then click **Inbound Message Type**.  
A sub-menu appears.
3. Click the **Search** option from the **Inbound Message Type** sub-menu.  
The **Inbound Message Type** screen appears.
4. In the **Inbound Message Type List** zone, click the **Edit** (✎) icon in the **Edit** column corresponding to the *Inbound message type* whose details you want to edit.

The **Inbound Message Type** screen appears. It contains the following sections:

- **Main** – Used to specify basic details about the inbound message type.
- **Characteristics** – Used to define characteristics for the inbound message type.

The **Main** section contains the following fields:

Field Name	Field Description	Mandatory (Yes or No)
Inbound Message Type	Displays the inbound message type.	Not applicable

Field Name	Field Description	Mandatory (Yes or No)
Business Object	Indicates the business object which is used while defining the inbound message type.	Not applicable
Customer Registration Type	<p>Used to indicate the customer registration type using which you want to create the customer registration object through a health care inbound message.</p> <div data-bbox="591 436 1105 1014" style="border: 1px solid black; padding: 5px;"> <p><b>Note:</b></p> <p>This field appears only when you are defining an inbound message type using the <b>C1-HCInboundMsgType</b> business object.</p> <p>While creating a health care inbound message type for the fully-insured health care business, you must use a customer registration type where the <b>Approval Required</b>, <b>Final Approval Required</b>, and <b>Manual Billing Hierarchy and Pricing</b> options are not selected. However, while creating a health care inbound message type for the self-funded health care business, you must use a customer registration type where the <b>Final Approval Required</b> and <b>Manual Billing Hierarchy and Pricing</b> options are selected, but the <b>Approval Required</b> option is not selected.</p> </div>	Yes
Person Business Object	<p>Used to indicate the business object using which you want to create a person when the customer or ASO customer inbound message is processed.</p> <div data-bbox="591 1152 1105 1331" style="border: 1px solid black; padding: 5px;"> <p><b>Note:</b> This field appears only when you are defining an inbound message type using the <b>C1-CustomerInboundMessageType</b> or <b>C1-ASOCustomerInboundMsgType</b> business object.</p> </div>	Yes
Account Business Object	<p>Used to indicate the business object using which you want to create an account when the customer or ASO customer inbound message is processed.</p> <div data-bbox="591 1470 1105 1648" style="border: 1px solid black; padding: 5px;"> <p><b>Note:</b> This field appears only when you are defining an inbound message type using the <b>C1-CustomerInboundMessageType</b> or <b>C1-ASOCustomerInboundMsgType</b> business object.</p> </div>	Yes

Field Name	Field Description	Mandatory (Yes or No)
Policy Type	<p>Used to indicate the policy type using which you want to create a policy when the ASO customer inbound message is processed.</p> <p><b>Note:</b> This field appears only when you are defining an inbound message type using the <b>C1-ASOCustomerInboundMsgType</b> business object.</p>	Yes
Policy Plan Business Object	<p>Used to indicate the business object using which you want to create a policy plan when the ASO customer inbound message is processed.</p> <p><b>Note:</b> This field appears only when you are defining an inbound message type using the <b>C1-ASOCustomerInboundMsgType</b> business object.</p>	Yes
Hold Request Business Object	<p>Used to indicate the business object using which you want to create a hold request for an account when the customer inbound message is processed.</p> <p><b>Note:</b> This field appears only when you are defining an inbound message type using the <b>C1-CustomerInboundMessageType</b> business object.</p>	Yes
Status on Policy Termination	<p>Used to indicate the status to which the policy must be transitioned when the policy termination request is processed through the customer inbound message.</p> <p><b>Note:</b> This field appears only when you are defining an inbound message type using the <b>C1-CustomerInboundMessageType</b> business object. You must specify a status which is already defined in the lifecycle of the <b>C1-POLICY</b> business object.</p>	Yes

Field Name	Field Description	Mandatory (Yes or No)
Status on Policy Reinstatement	Used to indicate the status to which the policy must be transitioned when the policy reinstatement request is processed through the customer inbound message.  <b>Note:</b> This field appears only when you are defining an inbound message type using the <b>C1-CustomerInboundMessageType</b> business object.  You must specify a status which is already defined in the lifecycle of the <b>C1-POLICY</b> business object.	Yes
Status on Policy Renewal	Used to indicate the status to which the policy must be transitioned when the policy renewal request is processed through the customer inbound message.  <b>Note:</b> This field appears only when you are defining an inbound message type using the <b>C1-CustomerInboundMessageType</b> business object.  You must specify a status which is already defined in the lifecycle of the <b>C1-POLICY</b> business object.	Yes
Inbound Message Business Object	Used to indicate the business object using which you want to create the respective inbound message.	Yes
Description	Used to specify the description for the inbound message type.	Yes
Status	Used to indicate the status of the inbound message type. The valid values are: <ul style="list-style-type: none"> <li>• Active</li> <li>• Inactive</li> </ul>	Yes
Detailed Description	Used to specify additional information about the inbound message type.	No

**Tip:** Alternatively, you can edit the details of an inbound message type by clicking the **Edit** button in the **Inbound Message Type** zone.

5. Modify the required details in the **Main** section.
6. Define, edit, or remove characteristics from the inbound message type, if required.
7. Click **Save**.

The changes made to the inbound message type are saved.

**Related Topics**

For more information on...	See...
<b>Inbound Message Type</b> screen	<a href="#">Inbound Message Type</a> on page 1981
<b>Inbound Message Type List</b> zone	<a href="#">Inbound Message Type List</a> on page 1982
<b>Inbound Message Type</b> zone	<a href="#">Inbound Message Type</a> on page 1983
How to define a characteristic for an inbound message type	<a href="#">Defining a Characteristic for an Inbound Message Type</a> on page 1991

**Copying an Inbound Message Type**

Instead of creating an inbound message type from scratch, you can create a new inbound message type using an existing inbound message type. This is possible through copying an inbound message type. On copying an inbound message type, the details including the characteristics are copied to the new inbound message type. You can then edit the details, if required.

**Prerequisites**

The following table lists the prerequisites for copying various inbound message types:

If you want to define a..	Then, you should have...
Customer Inbound Message Type	<ul style="list-style-type: none"> <li>• Customer inbound message type (whose copy you want to create) defined in the application</li> <li>• Customer inbound message business objects defined in the application</li> <li>• Person, account, and hold request business objects defined in the application</li> <li>• Status defined for the <b>C1-POLICY</b> business object to which a policy must be transitioned on policy termination</li> <li>• Status defined for the <b>C1-POLICY</b> business object to which a policy must be transitioned on policy renewal</li> <li>• Status defined for the <b>C1-POLICY</b> business object to which a policy must be transitioned on policy reinstatement</li> </ul>
Membership Inbound Message Type	<ul style="list-style-type: none"> <li>• Membership inbound message type (whose copy you want to create) defined in the application</li> <li>• Membership inbound message business objects defined in the application</li> </ul>
ASO Customer Inbound Message Type	<ul style="list-style-type: none"> <li>• ASO customer inbound message type (whose copy you want to create) defined in the application</li> <li>• ASO customer inbound message business objects defined in the application</li> <li>• Person, account, and policy plan business objects defined in the application</li> <li>• Policy types defined in the application</li> </ul>

If you want to define a..	Then, you should have...
Health Care Inbound Message Type	<ul style="list-style-type: none"> <li>• Health care inbound message type (whose copy you want to create) defined in the application</li> <li>• Health care inbound message business objects defined in the application</li> <li>• Customer registration types defined in the application</li> </ul>

### **Procedure**

To copy an inbound message type:

1. Click the **Admin** link in the **Application** toolbar.

A list appears.

2. From the **Admin** menu, select **I** and then click **Inbound Message Type**.

A sub-menu appears.

3. Click the **Search** option from the **Inbound Message Type** sub-menu.

The **Inbound Message Type** screen appears.

4. In the **Inbound Message Type List** zone, click the **Duplicate** () icon in the **Duplicate** column corresponding to the inbound message type whose copy you want to create.

The **Inbound Message Type** screen appears. It contains the following sections:

- **Main** – Used to specify basic details about the inbound message type.
- **Characteristics** – Used to define characteristics for the inbound message type.

The **Main** section contains the following fields:

Field Name	Field Description	Mandatory (Yes or No)
Inbound Message Type	Used to specify the inbound message type.	Yes
Business Object	Indicates the business object which is used while defining the inbound message type.	Not applicable

Field Name	Field Description	Mandatory (Yes or No)
Customer Registration Type	<p>Used to indicate the customer registration type using which you want to create the customer registration object through a health care inbound message.</p> <p><b>Note:</b> This field appears only when you are defining an inbound message type using the <b>C1-HCInboundMsgType</b> business object.</p> <p>While creating a health care inbound message type for the fully-insured health care business, you must use a customer registration type where the <b>Approval Required</b>, <b>Final Approval Required</b>, and <b>Manual Billing Hierarchy and Pricing</b> options are not selected. However, while creating a health care inbound message type for the self-funded health care business, you must use a customer registration type where the <b>Final Approval Required</b> and <b>Manual Billing Hierarchy and Pricing</b> options are selected, but the <b>Approval Required</b> option is not selected.</p>	Yes
Person Business Object	<p>Used to indicate the business object using which you want to create a person when the customer or ASO customer inbound message is processed.</p> <p><b>Note:</b> This field appears only when you are defining an inbound message type using the <b>C1-CustomerInboundMessageType</b> or <b>C1-ASOCustomerInboundMsgType</b> business object.</p>	Yes
Account Business Object	<p>Used to indicate the business object using which you want to create an account when the customer or ASO customer inbound message is processed.</p> <p><b>Note:</b> This field appears only when you are defining an inbound message type using the <b>C1-CustomerInboundMessageType</b> or <b>C1-ASOCustomerInboundMsgType</b> business object.</p>	Yes
Policy Type	<p>Used to indicate the policy type using which you want to create a policy when the ASO customer inbound message is processed.</p> <p><b>Note:</b> This field appears only when you are defining an inbound message type using the <b>C1-ASOCustomerInboundMsgType</b> business object.</p>	Yes

Field Name	Field Description	Mandatory (Yes or No)
Policy Plan Business Object	<p>Used to indicate the business object using which you want to create a policy plan when the ASO customer inbound message is processed.</p> <p><b>Note:</b> This field appears only when you are defining an inbound message type using the <b>C1-ASOCustomerInboundMsgType</b> business object.</p>	Yes
Hold Request Business Object	<p>Used to indicate the business object using which you want to create a hold request for an account when the customer inbound message is processed.</p> <p><b>Note:</b> This field appears only when you are defining an inbound message type using the <b>C1-CustomerInboundMessageType</b> business object.</p>	Yes
Status on Policy Termination	<p>Used to indicate the status to which the policy must be transitioned when the policy termination request is processed through the customer inbound message.</p> <p><b>Note:</b> This field appears only when you are defining an inbound message type using the <b>C1-CustomerInboundMessageType</b> business object. You must specify a status which is already defined in the lifecycle of the <b>C1-POLICY</b> business object.</p>	Yes
Status on Policy Reinstatement	<p>Used to indicate the status to which the policy must be transitioned when the policy reinstatement request is processed through the customer inbound message.</p> <p><b>Note:</b> This field appears only when you are defining an inbound message type using the <b>C1-CustomerInboundMessageType</b> business object. You must specify a status which is already defined in the lifecycle of the <b>C1-POLICY</b> business object.</p>	Yes



Field Name	Field Description	Mandatory (Yes or No)
Status on Policy Renewal	Used to indicate the status to which the policy must be transitioned when the policy renewal request is processed through the customer inbound message.  <b>Note:</b> This field appears only when you are defining an inbound message type using the <b>C1-CustomerInboundMessageType</b> business object.  You must specify a status which is already defined in the lifecycle of the <b>C1-POLICY</b> business object.	Yes
Inbound Message Business Object	Used to indicate the business object using which you want to create the respective inbound message.	Yes
Description	Used to specify the description for the inbound message type.	Yes
Status	Used to indicate the status of the inbound message type. The valid values are: <ul style="list-style-type: none"> <li>Active</li> <li>Inactive</li> </ul>	Yes
Detailed Description	Used to specify additional information about the inbound message type.	No

**Tip:** Alternatively, you can copy an inbound message type by clicking the **Duplicate** button in the **Inbound Message Type** zone.

- Enter the required details in the **Main** section.
- Define, edit, or remove characteristics from the inbound message type, if required.
- Click **Save**.

The new inbound message type is defined.

#### Related Topics

For more information on...	See...
<b>Inbound Message Type</b> screen	<a href="#">Inbound Message Type</a> on page 1981
<b>Inbound Message Type List</b> zone	<a href="#">Inbound Message Type List</a> on page 1982
<b>Inbound Message Type</b> zone	<a href="#">Inbound Message Type</a> on page 1983
How to define a characteristic for an inbound message type	<a href="#">Defining a Characteristic for an Inbound Message Type</a> on page 1991

## Deleting an Inbound Message Type

### Procedure

To delete an inbound message type:

1. Click the **Admin** link in the **Application** toolbar.  
A list appears.
2. From the **Admin** menu, select **I** and then click **Inbound Message Type**.  
A sub-menu appears.
3. Click the **Search** option from the **Inbound Message Type** sub-menu.  
The **Inbound Message Type** screen appears.
4. In the **Inbound Message Type List** zone, click the **Delete** (🗑️) icon in the **Delete** column corresponding to the Inbound message type that you want to delete.  
A message appears confirming whether you want to delete the inbound message type.

**Note:** You can delete an inbound message type only when an inbound message is not created using the inbound message type.

**Tip:** Alternatively, you can delete an inbound message type by clicking the **Delete** button in the **Inbound Message Type** zone.

5. Click **OK**.  
The inbound message type is deleted.

#### **Related Topics**

<b>For more information on...</b>	<b>See...</b>
<b>Inbound Message Type</b> screen	<a href="#">Inbound Message Type</a> on page 1981
<b>Inbound Message Type List</b> zone	<a href="#">Inbound Message Type List</a> on page 1982
<b>Inbound Message Type</b> zone	<a href="#">Inbound Message Type</a> on page 1983

## **Inbound Message (Used for Searching)**

---

The **Inbound Message** screen allows you to search for an inbound message using various search criteria. It contains the following zone:

- [Search Inbound Message](#) on page 2002

Through this screen, you can navigate to the following screen:

- [Inbound Message \(Used for Viewing\)](#) on page 2009

### **Search Inbound Message**

The **Search Inbound Message** zone allows you to search for an inbound message using various search criteria. It contains the following two sections:

- **Search Criteria** - The **Search Criteria** section contains the following fields:

Field Name	Field Description	Mandatory (Yes or No)
Search By	Used to indicate whether you want to search for an inbound message using the inbound message or person details. The valid values are: <ul style="list-style-type: none"> <li>• Message Details</li> <li>• Person Details</li> </ul> <div style="border: 1px solid black; padding: 2px;"><b>Note:</b> By default, the <b>Message Details</b> option is selected.</div>	Yes
Inbound Message ID	Used to search a particular inbound message. <div style="border: 1px solid black; padding: 2px;"><b>Note:</b> This field appears only when the <b>Message Details</b> option is selected from the <b>Search By</b> list.</div>	No
Status	Used to search inbound messages with a particular status. The valid values are: <ul style="list-style-type: none"> <li>• Pending</li> <li>• Processed</li> <li>• Rejected</li> <li>• Voided</li> </ul> <div style="border: 1px solid black; padding: 2px;"><b>Note:</b> This field appears only when the <b>Message Details</b> option is selected from the <b>Search By</b> list.</div>	No
Source System	Used to search inbound messages which are received from a particular external system. <div style="border: 1px solid black; padding: 2px;"><b>Note:</b> This field appears only when the <b>Message Details</b> option is selected from the <b>Search By</b> list.</div>	No
Created From	Used to search inbound messages which are created from a particular date onwards. <div style="border: 1px solid black; padding: 2px;"><b>Note:</b> This field appears only when the <b>Message Details</b> option is selected from the <b>Search By</b> list.</div>	No
External Source ID	Used to search inbound messages which are received from a particular external source system. <div style="border: 1px solid black; padding: 2px;"><b>Note:</b> This field appears only when the <b>Message Details</b> option is selected from the <b>Search By</b> list.</div>	No
Created To	Used to search inbound messages which are created till a particular date. <div style="border: 1px solid black; padding: 2px;"><b>Note:</b> This field appears only when the <b>Message Details</b> option is selected from the <b>Search By</b> list.</div>	No

Field Name	Field Description	Mandatory (Yes or No)
External Transaction ID	Used to search the inbound message which was a result of a particular transaction in the external source system.  <b>Note:</b> This field appears only when the <b>Message Details</b> option is selected from the <b>Search By</b> list.	No
User ID	Used to search inbound messages which are created by a particular user.  <b>Note:</b> This field appears only when the <b>Message Details</b> option is selected from the <b>Search By</b> list.	No
External Batch ID	Used to search inbound messages which are created through a particular batch job.  <b>Note:</b> This field appears only when the <b>Message Details</b> option is selected from the <b>Search By</b> list.	No
Inbound Message Type	Used to search inbound messages which are created using a particular inbound message type.  <b>Note:</b> This field appears only when the <b>Message Details</b> option is selected from the <b>Search By</b> list.	No
Person Name	Used to search inbound messages through which a particular person and its related entities are created or updated in the system.  <b>Note:</b> This field appears only when the <b>Person Details</b> option is selected from the <b>Search By</b> list.	No
Person Identifier Type	Used to indicate the person identifier type.  <b>Note:</b> This field appears only when the <b>Person Details</b> option is selected from the <b>Search By</b> list.	Yes (Conditional)  <b>Note:</b> If you specify the person identifier as a search criteria, you have to select the person identifier type.
Person Identifier	Used to search inbound messages through which a particular person and its related entities are created or updated in the system.  <b>Note:</b> This field appears only when the <b>Person Details</b> option is selected from the <b>Search By</b> list.	Yes (Conditional)  <b>Note:</b> If you specify the person identifier type as a search criteria, you have to specify the person identifier.

**Note:** You must specify at least one search criterion while searching for an inbound message.

- **Search Results** - On clicking the **Search** button, the search results appear based on the specified search criteria. The **Search Results** section contains the following columns:

Column Name	Column Description
Inbound Message Information	Displays information about the inbound message.  <b>Note:</b> It has a link. On clicking the link, the <b>Inbound Message</b> screen appears where you can view the details of the respective inbound message.
Status	Indicates the status of the inbound message. The valid values are: <ul style="list-style-type: none"> <li>• Pending</li> <li>• Processed</li> <li>• Rejected</li> <li>• Voided</li> </ul>
Inbound Message Type	Indicates the inbound message type using which the inbound message is created.
Source System	Indicates the source system from where the inbound message is received.
External Transaction ID	Indicates the transaction in the external source system which resulted in the inbound message.
External Source ID	Displays the external source system ID.
External Batch ID	Indicates the batch job in the external source system through which the inbound message is created.
Person Information	Indicates the person whose record is created or updated in the system through the inbound message. In addition, this column has a context menu which helps in navigating to other screens in the application.  <b>Note:</b> It has a link. On clicking the link, the <b>Person</b> screen appears where you can view the details of the respective person.
Created By	Indicates the user who has created the inbound message.  <b>Note:</b> This column appears only when the <b>Message Details</b> option is selected from the <b>Search By</b> list.
Creation Date	Displays the date when the inbound message is created in the system.

**Note:** Pagination is used to display limited number of records in the **Search Results** section. You can use the navigation links, such as **Previous** and **Next** to navigate between pages.

### **Related Topics**

For more information on...	See...
How to search for an inbound message	<a href="#">Searching for an Inbound Message</a> on page 2005
How to view the details of an inbound message	<a href="#">Viewing the Inbound Message Details</a> on page 2008

## **Searching for an Inbound Message**

### **Prerequisites**

To search for an inbound message, you should have:

- Inbound message types defined in the application
- Values defined for the **C1-SourceSystemLookup** extendable lookup
- Person identifier types defined in the application

### **Procedure**

To search for an inbound message:

1. Click the **Menu** link in the **Application** toolbar.  
A list appears.
2. From the **Main** menu, select **Integration** and then click **Inbound Message**.  
The **Inbound Message** screen appears.
3. Enter the search criteria in the **Search Inbound Message** zone.

**Note:** ORMB search engine supports wildcard search, where you can substitute the percentage (%) symbol as a stand in for any word or letter in a search criteria. You can use the ‘%’ wildcard character in all input fields except the date and ID fields. The ‘%’ wildcard character is suffixed automatically at the end of the partial search criteria. Therefore, you may or may not specify the wildcard character at the end of the partial search criteria. However, you have to prefix the wildcard character manually wherever required.

4. Click **Search**.

A list of inbound messages that meet the search criteria appears in the **Search Results** section.

### **Related Topics**

<b>For more information on...</b>	<b>See...</b>
<b>Inbound Message</b> screen	<a href="#">Inbound Message (Used for Searching)</a> on page 2002
<b>Search Inbound Message</b> zone	<a href="#">Search Inbound Message</a> on page 2002

## **Creating an Inbound Message**

Oracle Revenue Management and Billing allows you to create the following inbound messages by calling the respective inbound web service:

<b>Inbound Message</b>	<b>Inbound Web Service</b>
<a href="#">Customer Inbound Message</a> on page 1758	<a href="#">CI-CustomerStructureInboundMessage</a> on page 2006
<a href="#">Membership Inbound Message</a> on page 1796	<a href="#">CI-MembershipInboundMessage</a> on page 2007
<a href="#">ASO Customer Inbound Message</a> on page 1826	<a href="#">CI-ASOCustomerInboundMessage</a> on page 2007
<a href="#">Health Care Inbound Message</a> on page 1863	<a href="#">CI-HCInboundMessage</a> on page 2008

You cannot create the above inbound messages from the user interface. However, you can define, edit, and remove a characteristic from the above inbound messages from the user interface. You can delete and submit the above inbound messages for validation and processing from the user interface and through a batch process.

### **C1-CustomerStructureInboundMessage**

The **C1-CustomerStructureInboundMessage** inbound web service enables you to create or update a person, account, contract, policy, policy plan, packaged savings, and billable charge for packaged savings. It also allows you to terminate, reinstate, or renew a policy. In addition, it allows you to hold an account for a given time period. However, only the bill generation process is kept on hold when the hold request is created for an account through a customer inbound message.

On calling the **C1-CustomerStructureInboundMessage** inbound web service, a customer inbound message is created in the **Pending** status. A customer inbound message goes through various statuses in its lifecycle. You can search for a customer inbound message through the **Inbound Message** screen.

Before calling the **C1-CustomerStructureInboundMessage** inbound web service, you need to ensure that the prerequisites are setup as mentioned in [Prerequisites](#) on page 1758.

#### **Related Topics**

For more information on...	See...
<b>Inbound Message</b> screen	<a href="#">Inbound Message (Used for Searching)</a> on page 2002
Customer Inbound Message Status Transition through User Interface	<a href="#">Customer Inbound Message Status Transition through User Interface</a> on page 1759
Customer Inbound Message Status Transition through a Batch Process	<a href="#">Customer Inbound Message Status Transition through a Batch Process</a> on page 1760

#### **C1-MembershipInboundMessage**

The **C1-MembershipInboundMessage** inbound web service enables you to create or update a membership in a policy plan, add or remove dependents from a membership, create or update the main subscriber or dependent person, associate a contract with a membership, add membership premium for a coverage period, or create billable charges for membership premium.

On calling the **C1-MembershipInboundMessage** inbound web service, a membership inbound message is created in the **Pending** status. A membership inbound message goes through various statuses in its lifecycle. You can search for a membership inbound message through the **Inbound Message** screen.

Before calling the **C1-MembershipInboundMessage** inbound web service, you need to ensure that the prerequisites are setup as mentioned in [Prerequisites](#) on page 1796.

#### **Related Topics**

For more information on...	See...
<b>Inbound Message</b> screen	<a href="#">Inbound Message (Used for Searching)</a> on page 2002
Membership Inbound Message Status Transition through User Interface	<a href="#">Membership Inbound Message Status Transition through User Interface</a> on page 1797
Membership Inbound Message Status Transition through a Batch Process	<a href="#">Membership Inbound Message Status Transition through a Batch Process</a> on page 1798

#### **C1-ASOCustomerInboundMessage**

The **C1-ASOCustomerInboundMessage** inbound web service enables you to create or update a parent customer and its bill groups. In addition, it allows you to create or update an account and self-funded policy for a bill group.

On calling the **C1-ASOCustomerInboundMessage** inbound web service, an ASO customer inbound message is created in the **Pending** status. An ASO customer inbound message goes through various statuses in its lifecycle. You can search for an ASO customer inbound message through the **Inbound Message** screen.

Before calling the **C1-ASOCustomerInboundMessage** inbound web service, you need to ensure that the prerequisites are setup as mentioned in [Prerequisites](#) on page 1828

#### **Related Topics**

For more information on...	See...
<b>Inbound Message</b> screen	<a href="#">Inbound Message (Used for Searching)</a> on page 2002

For more information on...	See...
ASO Customer Inbound Message Status Transition through User Interface	<a href="#">ASO Customer Inbound Message Status Transition through User Interface</a> on page 1828
ASO Customer Inbound Message Status Transition through a Batch Process	<a href="#">ASO Customer Inbound Message Status Transition through a Batch Process</a> on page 1829

### C1-HCInboundMessage

The **C1-HCInboundMessage** inbound web service enables you to create or update a person, account and self-funded or fully-insured group policy. It also allows you to create or update a policy plan, membership, and pass-through billable charge for a fully-insured group policy. In addition, it allows you to terminate, reinstate, or renew a fully-insured group policy.

On calling the **C1-HCInboundMessage** inbound web service, a health care inbound message is created in the **Pending** status. A health care inbound message goes through various statuses in its lifecycle. You can search for a health care inbound message through the **Inbound Message** screen.

Before calling the **C1-HCInboundMessage** inbound web service, you need to ensure that the prerequisites are setup as mentioned in [Prerequisites](#) on page 1869.

#### Related Topics

For more information on...	See...
<b>Inbound Message</b> screen	<a href="#">Inbound Message (Used for Searching)</a> on page 2002
Health Care Inbound Message Status Transition through User Interface	<a href="#">Health Care Inbound Message Status Transition through User Interface</a> on page 1871
Health Care Inbound Message Status Transition through a Batch Process	<a href="#">Health Care Inbound Message Status Transition through a Batch Process</a> on page 1872

## Viewing the Inbound Message Details

### Procedure

To view the details of an inbound message:

1. Search for the inbound message in the **Inbound Message** screen.
2. In the **Search Results** section, click the link in the **Inbound Message Information** column corresponding to the inbound message whose details you want to view.

The **Inbound Message** screen appears.

3. Ensure that the **Main** tab is selected.
4. View the details of the inbound message in the **Inbound Message** zone.

#### Related Topics

For more information on...	See...
How to search for an inbound message	<a href="#">Searching for an Inbound Message</a> on page 2005
<b>Inbound Message</b> screen	<a href="#">Inbound Message (Used for Viewing)</a> on page 2009
<b>Inbound Message</b> zone	<a href="#">Inbound Message</a> on page 2009



## Inbound Message (Used for Viewing)

Once an inbound message is created, the **Inbound Message** screen allows you to:

- View the details of the inbound message
- Edit the details of the inbound message
- Delete the inbound message
- Submit the inbound message for validation and processing
- Resubmit the inbound message for validation and processing on failure
- Void the inbound message
- View the content of the inbound message
- View the log of the inbound message
- Add a log entry for the inbound message

The **Inbound Message** screen contains the following tabs:

- [Inbound Message - Main](#) on page 2009
- [Inbound Message - Message](#) on page 2011
- [Inbound Message - Log](#) on page 2012

### Inbound Message - Main

The **Main** tab displays information about the inbound message. It contains the following zone:

- [Inbound Message](#) on page 2009

### Inbound Message

The **Inbound Message** zone displays the details of the inbound message. It contains the following sections:

- **Main** – Displays basic information about the inbound message. It contains the following fields:

Field Name	Field Description
Inbound Message Information	Displays information about the inbound message.
Status	Indicates the status of the inbound message. The valid values are: <ul style="list-style-type: none"> <li>• Pending</li> <li>• Processed</li> <li>• Rejected</li> <li>• Voided</li> </ul>
Inbound Message Type	Indicates the inbound message type using which the inbound message is created. <div style="border: 1px solid black; padding: 5px; margin-top: 10px;"> <p><b>Note:</b> It has a link. On clicking the link, the <b>Inbound Message Type</b> screen appears where you can view the details of the respective inbound message type.</p> </div>
Source System	Indicates the external source system from where the inbound message is received.

Field Name	Field Description
External Transaction ID	Indicates the transaction in the external source system which resulted in the inbound message.
External Batch ID	Indicates the external batch job through which the inbound message is created.
External Source ID	Displays the external source system ID.

- **Characteristics** – Lists the characteristics defined for the inbound message. It contains the following columns:

Column Name	Column Description
Effective Date	Displays the date from when the characteristic is effective for the inbound message.
Characteristic Type	Indicates the characteristic type.
Characteristic Value	Displays the value of the characteristic type.

- **Record Actions** – This section contains the following buttons:

Button Name	Button Description
Edit	Used to define, edit, or remove characteristics from the inbound message. <b>Note:</b> The <b>Edit</b> button appears only when the inbound message is in the <b>Pending</b> or <b>Rejected</b> status.
Delete	Used to delete the inbound message. <b>Note:</b> The <b>Delete</b> button appears only when the inbound message is in the <b>Pending</b> status.
Submit for Processing	Used to submit the inbound message for validation and processing. <b>Note:</b> The <b>Submit for Processing</b> button appears only when the inbound message is in the <b>Pending</b> status.
Retry	Used when you want to change the status of the inbound message from <b>Rejected</b> to <b>Pending</b> so that the inbound message can be considered once again for validation and processing. <b>Note:</b> The <b>Retry</b> button appears only when the inbound message is in the <b>Rejected</b> status.
Void	Used to cancel the inbound message. <b>Note:</b> The <b>Void</b> button appears only when the inbound message is in the <b>Rejected</b> status.

- **Record Information** – This section contains the following fields:

Field Name	Field Description
Business Object	Indicates the business object using which the inbound message is created. In addition, a context menu appears corresponding to this field which helps in navigating to other screens in the application.  <b>Note:</b> It has a link. On clicking the link, the <b>Business Object</b> screen appears where you can view the details of the respective business object.
Status Date/Time	Displays the date and time when the status of the inbound message is updated.
Create Date/Time	Displays the date and time when the inbound message is created.

## Inbound Message - Message

The **Message** tab displays the content of the inbound message in the XML format. It contains the following zone:

- [Inbound Message Content](#) on page 2011

### Inbound Message Content

The **Inbound Message Content** zone displays the content of the inbound message in the XML format. By default, each tag in the inbound message is expanded. You can collapse the tag whenever required.

For more information about the tags, refer to the respective XML format section:

Inbound Message	XML Format
Customer Inbound Message	<a href="#">Customer Inbound Message XML Format</a> on page 1773
Membership Inbound Message	<a href="#">Membership Inbound Message XML Format</a> on page 1809
ASO Customer Inbound Message	<a href="#">ASO Customer Inbound Message XML Format</a> on page 1833
Health Care Inbound Message	<a href="#">Health Care Inbound Message XML Format</a> on page 1875

Once the inbound message is validated and processed either from the user interface or through a batch process, the following tags appear at the bottom of the inbound message in the **Inbound Message Content** zone:

Tag Name	Tag Description
toDoRetry	Displays the information about the retry option used for the inbound message.
retryDateTime	Displays the date and time when the retry option is used to change the status of the inbound message from <b>Rejected</b> to <b>Pending</b> .
numberOfRetries	Indicates the number of times the retry option is used for the inbound message.
currentErrorState	Indicates the status to which the inbound message is transitioned when its validation or processing fails. The valid value is: <ul style="list-style-type: none"> <li>• REJECTED</li> </ul>
isRetried	Indicates whether the retry option is used to change the status of the inbound message. The valid values are: <ul style="list-style-type: none"> <li>• true</li> <li>• false</li> </ul>

### Related Topics

For more information on...	See...
How to view the content of an inbound message	<a href="#">Viewing the Content of an Inbound Message</a> on page 2018

## Inbound Message - Log

The **Log** tab contains the following zone:

- [Inbound Message Log](#) on page 2012

### Inbound Message Log

The **Inbound Message Log** zone lists the complete trail of actions performed on the inbound message. It contains the following columns:

Column Name	Column Description
Date/Time	Displays the date and time when the action was performed on the inbound message.
Details	Displays the details about the action performed on the inbound message.
User	Indicates the user who has performed the action on the inbound message.
Log Type	Indicates the type of the log.
Related Object	Indicates the object or entity which is created when the action is performed on the inbound message.
Status Reason	Indicates the reason why the status of the inbound message is changed.  <b>Note:</b> At present, no data appears in this column. The implementation team can build the custom logic to meet the business requirements.

**Note:** You can manually add a log entry for the inbound message by clicking the **Add Log Entry** link in the upper right corner of the **Inbound Message Log** zone.

### Related Topics

For more information on...	See...
How to view the log of an inbound message	<a href="#">Viewing the Log of an Inbound Message</a> on page 2019
How to add a log entry for an inbound message	<a href="#">Adding a Log Entry for an Inbound Message</a> on page 2019

## Editing an Inbound Message

### Procedure

To edit an inbound message:

1. Search for the inbound message in the **Inbound Message** screen.
2. In the **Search Results** section, click the link in the **Inbound Message Information** column corresponding to the inbound message whose details you want to edit.

The **Inbound Message** screen appears.

3. Ensure that the **Main** tab is selected.
4. Click the **Edit** button in the **Inbound Message** zone.

The **Inbound Message** screen appears. It contains the following sections:

- **Main** - Displays the basic information about the inbound message. It contains the following fields:

Field Name	Field Description
Inbound Message Information	Displays information about the inbound message.
Inbound Message Type	Indicates the inbound message type using which the inbound message is created.
Source System	Indicates the source system from where the inbound message is received.
External Transaction ID	Indicates the transaction in the external source system which resulted in the inbound message.
External Batch ID	Indicates the batch job in the external source system through which the inbound message is created.
External Source ID	Displays the external source system ID.

- **Characteristics** - Used to define, edit, or remove characteristics from the inbound message.

**Note:** The **Edit** button appears only when the inbound message is in the **Pending** or **Rejected** status.

5. Define, edit, or remove characteristics from the inbound message, if required.
6. Click **Save**.

The changes made to the inbound message are saved.

#### **Related Topics**

For more information on...	See...
How to search for an inbound message	<a href="#">Searching for an Inbound Message</a> on page 2005
<b>Inbound Message</b> screen	<a href="#">Inbound Message (Used for Viewing)</a> on page 2009
<b>Inbound Message</b> zone	<a href="#">Inbound Message</a> on page 2009
How to define a characteristic for an inbound message	<a href="#">Defining a Characteristic for an Inbound Message</a> on page 2013

## **Defining a Characteristic for an Inbound Message**

### **Prerequisites**

To define a characteristic for an inbound message, you should have:

- Characteristic types defined in the application (where the characteristic entity is set to **Inbound Message**)

### **Procedure**

To define a characteristic for an inbound message:

1. Ensure that the **Characteristics** section is expanded when you are editing an inbound message.

The **Characteristics** section contains the following fields in a grid:

Field Name	Field Description	Mandatory (Yes or No)
Effective Date	Used to specify the date from when the characteristic is effective for the inbound message.	Yes (Conditional) <b>Note:</b> This field is required when you are defining a characteristic for the inbound message.
Characteristic Type	Used to indicate the characteristic type. <b>Note:</b> The list includes only those characteristic types where the characteristic entity is set to <b>Inbound Message</b> .	Yes (Conditional) <b>Note:</b> This field is required when you are defining a characteristic for the inbound message.
Characteristic Value	Used to specify the value for the characteristic type. <b>Note:</b> If you select a predefined characteristic type, the <b>Search</b>  icon appears corresponding to the <b>Characteristic Value</b> field. On clicking the <b>Search</b> icon, the <b>Predefined Characteristic Search</b> window appears.  On specifying the value for a predefined characteristic type, the description of the characteristic value appears corresponding to the <b>Characteristic Value</b> field.	Yes (Conditional) <b>Note:</b> This field is required when you are defining a characteristic for the inbound message.

- Enter the required details in the **Characteristics** section.
- If you want to define more than one characteristic for the inbound message, click the **Add**  icon and then repeat step 2.

**Note:** However, if you want to remove a characteristic from the inbound message, click the **Delete**  icon corresponding to the characteristic.

- Click **Save**.

The characteristics are defined for the inbound message.

### Related Topics

For more information on...	See...
How to edit an inbound message	<a href="#">Editing an Inbound Message</a> on page 2012

## Deleting an Inbound Message

There might be situations when incorrect inbound messages are received in the system. In such case, the system provides you with an ability to delete the inbound message when it is not yet validated or processed. Note that you can delete an inbound message only when the inbound message is in the **Pending** status.

### Procedure

To delete an inbound message:

1. Search for the inbound message in the **Inbound Message** screen.
2. In the **Search Results** section, click the link in the **Inbound Message Information** column corresponding to the inbound message that you want to delete.

The **Inbound Message** screen appears.

3. Ensure that the **Main** tab is selected.
4. Click the **Delete** button in the **Inbound Message** zone.

A message appears confirming whether you want to delete the inbound message.

**Note:** The **Delete** button appears only when the inbound message is in the **Pending** status.

5. Click **OK**.

The inbound message is deleted.

### **Related Topics**

<b>For more information on...</b>	<b>See...</b>
How to search for an inbound message	<a href="#">Searching for an Inbound Message</a> on page 2005
<b>Inbound Message</b> screen	<a href="#">Inbound Message (Used for Viewing)</a> on page 2009
<b>Inbound Message</b> zone	<a href="#">Inbound Message</a> on page 2009

## **Processing an Inbound Message**

### **Prerequisites**

The following table lists the prerequisites which you should setup before processing the respective inbound message:

<b>Inbound Message</b>	<b>Refer to...</b>
Customer Inbound Message	<a href="#">Prerequisites</a> on page 1758
Membership Inbound Message	<a href="#">Prerequisites</a> on page 1796
ASO Customer Inbound Message	<a href="#">Prerequisites</a> on page 1828
Health Care Inbound Message	<a href="#">Prerequisites</a> on page 1869

### **Procedure**

To process an inbound message:

1. Search for the inbound message in the **Inbound Message** screen.
2. In the **Search Results** section, click the link in the **Inbound Message Information** column corresponding to the inbound message that you want to submit for validation and processing.

The **Inbound Message** screen appears.

3. Ensure that the **Main** tab is selected.
4. Click the **Submit for Processing** button in the **Inbound Message** zone.

The status of the inbound message is changed to **Validation** and the algorithms attached to the **Validation** status are invoked in the specified sequence. If the validation is successful, the status of the inbound message is changed to **Processing** and the algorithms attached to the **Processing** status are invoked in the specified sequence. The following table lists how the system behaves when the respective inbound message is processed:

If the inbound message is a...	Then...
Customer inbound message	<p>Creates or updates a person, account, contract, policy, policy plan, packaged savings, and billable charge for packaged savings. If requested, it terminates, reinstates, or renews a policy. In addition, if requested, it holds an account for a given time period. However, only the bill generation process is kept on hold when the hold request is created for an account through a customer inbound message. Finally, status of the inbound message is changed to <b>Processed</b>.</p> <p>It creates a person and account using the person and account business objects, respectively, as specified in the inbound message type. It creates a policy using the policy type specified in the <b>C1-CINMSGPRC</b> algorithm. It creates a policy plan using the <b>Policy Plan BO (C1PPLNBO)</b> characteristic defined on the policy type.</p>
Membership inbound message	<p>Creates or updates a membership in a policy plan, adds or removes dependents from a membership, creates or updates the main subscriber or dependent person, associates a contract with a membership, adds membership premium for a coverage period, or creates billable charges for membership premium. Finally, the status of the inbound message is changed to <b>Processed</b>.</p> <p>It creates a membership using the <b>Membership BO (C1MEMBRO)</b> characteristic defined on the policy type. If the person who is the main subscriber or dependent in a membership does not exist, the system creates main subscriber or dependent person using the person business object specified in the inbound message type.</p>
ASO Customer Inbound Message	<p>Creates or updates a parent customer and its bill groups. In addition, it creates or updates an account and self-funded policy of a bill group. Finally, the status of the inbound message is changed to <b>Processed</b>.</p> <p>It creates a parent customer and bill group using the person business object specified in the inbound message type. It creates an account using the account business object specified in the inbound message type. It creates a self-funded policy using the policy type specified in the inbound message type.</p>



If the inbound message is a...	Then...
Health Care Inbound Message	<p>Creates or updates a person, account and self-funded or fully-insured group policy. It creates or updates a policy plan, membership, and pass-through billable charge for a fully-insured group policy. In addition, if requested, it terminates, reinstates, or renews a fully-insured group policy. Finally, the status of the inbound message is changed to <b>Processed</b>.</p> <p>The system uses the <b>C1-PERSTYPE</b> feature configuration to decide whether the person type specified in the health care inbound message represents <b>Parent Customer</b> or <b>Bill Group</b>. If the person type specified in the health care inbound message matches the person type specified in the <b>Bill Group Person Type</b> or <b>Parent Person Type</b> option type of the <b>C1-PERSTYPE</b> feature configuration, the system creates or updates the person, account, policy, policy plan, and address through a customer registration object. Note that the memberships, pass-through billable charges, and pricing rules are created directly and not via customer registration object. However, if the person type specified in the health care inbound message does not match the person type specified in the <b>Bill Group Person Type</b> or <b>Parent Person Type</b> option type, the system creates or updates the person and its other entities directly and not through a customer registration object. In this case, the system only refers the customer registration type for the business objects using which the person, account, policy plan, membership, and address should be created or updated in the system.</p> <p>If the derivation and pricing parameters are specified for a bill group, the system automatically creates one sort record for the bill group. Here, the sort ID is set to the bill group ID. The start and end dates of the sort record are set to the bill group and parent customer's relationship start and end dates. Once the sort record is created, the system creates the derivation and pricing parameters for the bill group and sort ID combination.</p>

However, if the validation or processing fails due to any reason, the status of the inbound message is changed to **Rejected** and the algorithms attached to the **Rejected** status are invoked in the specified sequence. A To Do is created using the To Do type specified in the **C1-TDCRINMSG** algorithm and assigned to the users with the To Do role specified in the **C1-TDCRINMSG** algorithm.

**Note:** The **Submit for Processing** button appears only when the inbound message is in the **Pending** status.

### Related Topics

For more information on...	See...
How to search for an inbound message	<a href="#">Searching for an Inbound Message</a> on page 2005
Inbound Message screen	<a href="#">Inbound Message (Used for Viewing)</a> on page 2009
Inbound Message zone	<a href="#">Inbound Message</a> on page 2009

## Using the Retry Option for an Inbound Message

If the validation or processing fails due to any reason, the status of the inbound message is changed to **Rejected**. The system enables you to resubmit the inbound messages for validation and processing on failure. However, to resubmit the inbound message for validation and processing, you need to change the status of the inbound message from **Rejected** to **Pending**. This is possible through using the **Retry** option.

### Procedure

To use the retry option for an inbound message:

1. Search for the inbound message in the **Inbound Message** screen.
2. In the **Search Results** section, click the link in the **Inbound Message Information** column corresponding to the inbound message for which you want to use the retry option.

The **Inbound Message** screen appears.

3. Ensure that the **Main** tab is selected.
4. Ensure that the To Dos created for the inbound message are in the **Complete** status.
5. Click the **Retry** button in the **Inbound Message** zone.

The status of the inbound message is changed to **Pending**.

**Note:** The **Retry** button appears only when the inbound message is in the **Rejected** status.

### Related Topics

For more information on...	See...
How to search for an inbound message	<a href="#">Searching for an Inbound Message</a> on page 2005
<b>Inbound Message</b> screen	<a href="#">Inbound Message (Used for Viewing)</a> on page 2009
<b>Inbound Message</b> zone	<a href="#">Inbound Message</a> on page 2009

## Voiding an Inbound Message

There might be situations when incorrect inbound messages are received in the system. In such case, the system provides you with an ability to void or cancel the inbound message after the validation or processing fails. Note that you can void or cancel an inbound message only when the inbound message is in the **Rejected** status.

### Procedure

To void an inbound message:

1. Search for the inbound message in the **Inbound Message** screen.
2. In the **Search Results** section, click the link in the **Inbound Message Information** column corresponding to the inbound message that you want to void.

The **Inbound Message** screen appears.

3. Ensure that the **Main** tab is selected.
4. Click the **Void** button in the **Inbound Message** zone.

The status of the inbound message is changed to **Voided**.

**Note:** The **Void** button appears only when the inbound message is in the **Rejected** status.

### Related Topics

For more information on...	See...
How to search for an inbound message	<a href="#">Searching for an Inbound Message</a> on page 2005
<b>Inbound Message</b> screen	<a href="#">Inbound Message (Used for Viewing)</a> on page 2009
<b>Inbound Message</b> zone	<a href="#">Inbound Message</a> on page 2009

## Viewing the Content of an Inbound Message

**Procedure**

To view the content of an inbound message:

1. Search for the inbound message in the **Inbound Message** screen.
2. In the **Search Results** section, click the link in the **Inbound Message Information** column corresponding to the inbound message whose details you want to view.

The **Inbound Message** screen appears.

3. Click the **Message** tab.

The **Message** tab appears.

4. View the content of the inbound message in the XML format in the **Inbound Message Content** zone.

**Related Topics**

For more information on...	See...
How to search for an inbound message	<a href="#">Searching for an Inbound Message</a> on page 2005
<b>Inbound Message</b> screen	<a href="#">Inbound Message (Used for Viewing)</a> on page 2009
<b>Inbound Message Content</b> zone	<a href="#">Inbound Message Content</a> on page 2011

**Viewing the Log of an Inbound Message****Procedure**

To view the log of an inbound message:

1. Search for the inbound message in the **Inbound Message** screen.
2. In the **Search Results** section, click the link in the **Inbound Message Information** column corresponding to the inbound message whose log you want to view.

The **Inbound Message** screen appears.

3. Click the **Log** tab.

The **Log** tab appears.

4. View the complete trail of actions performed on the inbound message in the **Inbound Message Log** zone.

**Related Topics**

For more information on...	See...
How to search for an inbound message	<a href="#">Searching for an Inbound Message</a> on page 2005
<b>Inbound Message</b> screen	<a href="#">Inbound Message (Used for Viewing)</a> on page 2009
<b>Inbound Message Log</b> zone	<a href="#">Inbound Message Log</a> on page 2012
How to add a log entry for an inbound message	<a href="#">Adding a Log Entry for an Inbound Message</a> on page 2019

**Adding a Log Entry for an Inbound Message****Procedure**

To add a log entry for an inbound message:

1. Search for the inbound message in the **Inbound Message** screen.

- In the **Search Results** section, click the link in the **Inbound Message Information** column corresponding to the inbound message for which you want to add a log entry.

The **Inbound Message** screen appears.

- Click the **Log** tab.

The **Log** tab appears.

- Click the **Add Log Entry** link in the upper right corner of the **Inbound Message Log** zone.

The **Add Inbound Message Log** window appears. It contains the following fields:

Field Name	Field Description	Mandatory (Yes or No)
Inbound Message Information	Displays information about the inbound message.	Not applicable
Log Details	Used to specify additional comments on the inbound message.	Yes

- Enter the comments in the **Log Details** field.
- Click **Save**.

The log entry is added in the **Inbound Message Log** zone.

#### **Related Topics**

For more information on...	See...
How to search for an inbound message	<a href="#">Searching for an Inbound Message</a> on page 2005
<b>Inbound Message</b> screen	<a href="#">Inbound Message (Used for Viewing)</a> on page 2009
<b>Inbound Message Log</b> zone	<a href="#">Inbound Message Log</a> on page 2012

---

# Chapter 28

---

## Health Insurance Policy

---

### Topics:

- [Pre-requisites \(for Fully-Insured Policy\)](#)
- [Pre-requisites \(for Self-Funded Policy\)](#)
- [Types of Policies](#)
- [Fully-Insured Policy Status Transition](#)
- [Self-Funded Policy Status Transition](#)
- [Membership Status Transition](#)
- [Algorithms Used in C1-POLICY](#)
- [Algorithms Used in C1-PolicyPlan](#)
- [Algorithms Used in C1-Membership](#)
- [Algorithms Used in C1-ASOPolicy](#)
- [Policy Type](#)
- [Policy Person Role](#)
- [Contract Relationship Type](#)
- [Source System Extendable Lookup](#)
- [Extendable Lookup \(Source System\)](#)
- [Policy \(Used for Searching\)](#)
- [Policy \(Used for Viewing\)](#)
- [Policy Plan \(Used for Viewing\)](#)
- [Membership \(Used for Searching\)](#)
- [Membership \(Used for Viewing\)](#)

Health insurance is a type of insurance coverage that pays for medical and surgical expenses incurred by the insured. Health insurance can reimburse the insured for expenses incurred from illness or injury, or pay the care provider directly. Health insurance policy is a contract between the insurer and the insured, known as the policy holder.

A small, middle, or large organization can opt for a fully-insured or self-funded health care plan for its employees. A fully-insured health plan is the traditional way to structure an employer-sponsored health plan. In the fully-insured plan, the employer contracts an insurance company to cover the employees and dependents. The employer pays a premium to the insurance carrier. The premium rates are fixed for a year, based on the number of employees enrolled in the plan each month. The monthly premium changes during the year when the number of enrolled employees in the plan changes. The insurance carrier collects the premiums and pays the health care claims based on the coverage benefits outlined in the policy. The covered persons (i.e. employees and dependents) are responsible to pay any deductible amounts or co-payments required for covered services under the policy.

In self-funded health plan, employers (usually larger) operate their own health plan. Employers choose to self-insure because it allows them to save the profit margin that an insurance company adds to its premium for a fully-insured plan. However, self-insuring exposes the company to much larger risk in the event that more claims than expected must be paid.

Oracle Revenue Management and Billing enables you to create policies for the fully-insured and self-funded health care plans. You can also import the policy data from the policy processing system through a health care inbound message and then view such policy data in the system.

You can create a fully-insured policy using the **C1-POLICY** business object and a self-funded policy using the **C1-ASOPolicy** business object. The fully-insured and self-funded policies go through various statuses in their lifecycle. For more information, see [Fully-Insured Policy Status Transition](#) on page 2044 and [Self-Funded Policy Status Transition](#) on page 2045 processes.

## Pre-requisites (for Fully-Insured Policy)

---

To use the fully-insured policy feature, you need to do the following:

- Define the required policy types in the system.
- Define the required policy person roles in the system.
- Define the values for the **C1-SourceSystemLookup** extendable lookup.
- Define the required characteristic types where the characteristic entity is set to **Policy Type**.
- Define the required characteristic types where the characteristic entity is set to **Policy**.
- Define the status reasons for the **Terminated** status of the **C1-POLICY** business object in the **Status Reason** screen.
- Define the status reasons for the **Reinstated** status of the **C1-POLICY** business object in the **Status Reason** screen.
- Define the required price items in the system.
- Define the required pricing rule types where the pricing rule type category is set to **Age Based**, **Tier Based**, or **Pass-Through Billable Charge**.
- Define the required characteristic types where the characteristic entity is set to **Policy Plan**.
- Define the required contract relationship types in the system.
- Define the required characteristic types where the characteristic entity is set to **Membership**.
- Define the required characteristic types where the characteristic entity is set to **Membership Person**.
- Define the required contracts (which you want to associate with a membership) in the system.
- Define the values for the **BILL\_TO\_TYPE\_FLG** lookup field
- Define the required parameter values in the following algorithm which is attached to the **C1-POLICY** business object:
  - C1-POLBOVAL
- Define the required parameter values in the following algorithms which are used in the lifecycle of the **C1-POLICY** business object:
  - C1-EVCSTSTAT
  - C1-PLCYTRMRQ
  - C1-POLCYTERM
  - C1-DELTRMLTR
  - C1-PLCYREIRQ
  - C1-POLCYREIN
  - C1-CCPOLRE1
- Set the values for the following option types in the **C1-ASOBLNG** feature configuration:
  - Membership ID Characteristic for Billable Charge
  - Parent Customer Policy Person Role
  - Bill Group Policy Person Role
  - Membership Inactive Status

- Membership Person Inactive Status

### Related Topics

For more information on...	See...
How to setup the <b>C1-ASOBLLNG</b> feature configuration	<a href="#">Setting the C1-ASOBLLNG Feature Configuration</a> on page 2889

## Pre-requisites (for Self-Funded Policy)

To use the self-funded policy feature, you need to do the following:

- Define the required policy types in the system.
- Define the required policy person roles in the system.
- Define the values for the **RUNOUT\_ADM\_OPT\_FLG** lookup field.
- Define the required characteristic types where the characteristic entity is set to **Policy Type**.
- Define the required characteristic types where the characteristic entity is set to **Policy**.
- Define the required parameter values in the following algorithm which is attached to the **C1-ASOPolicy** business object:
  - C1-ASOBOPOSP
- Define the required parameter values in the following algorithm which is used in the lifecycle of the **C1-ASOPolicy** business object:
  - C1-ASOPOLMOA
- Set the values for the following option types in the **C1-ASOBLLNG** feature configuration:
  - Parent Customer Policy Person Role
  - Bill Group Policy Person Role
- Set the batch control type of the **Policy Periodic Monitor (C1-POLPR)** batch to **Timed** and define the following attributes:
  - Time Interval
  - Timer Active
  - User ID
  - Batch Language
  - Email Address

### Related Topics

For more information on...	See...
How to setup the <b>C1-ASOBLLNG</b> feature configuration	<a href="#">Setting the C1-ASOBLLNG Feature Configuration</a> on page 2889

## Types of Policies

The system enables you to create policies for different lines of business in the health care domain, such as policies for:

- Fully-Insured Health Care Business

- Self-Funded Health Care Business

## Fully-Insured Policy

You can create a fully-insured policy using a policy type where the policy category is set to **Fully-Insured Group** or **Fully-Insured Individual**. The policy type indicates the business object using which the fully-insured policy should be created in the system.

**Note:** At present, the **Fully-Insured Individual** policy category is not yet supported in the system.

As per the fully-insured health care business, the system enables you to create a fully-insured policy for the following:

- A parent customer (where a bill group is not associated)
- A bill group (where the parent customer is the policy holder)

You can create or edit a fully-insured policy from the **Policy** screen. In addition, you can create or edit a fully-insured policy through a customer registration object or a health care inbound message. If the fully-insured policy information is given for a bill group in a health care inbound message, the system does the following:

- Associates the bill group with the policy using the policy person role which is specified in the **Bill Group Policy Person Role** option type of the **C1-ASOBLLNG** feature configuration
- Associates the parent customer with the policy using the policy person role which is specified in the **Parent Customer Policy Person Role** option type of the **C1-ASOBLLNG** feature configuration

However, if the fully-insured policy information is given for a parent customer in a health care inbound message, the system does the following:

- Associates the parent customer with the policy using the policy person role which is specified in the **Parent Customer Policy Person Role** option type of the **C1-ASOBLLNG** feature configuration

A fully-insured policy encapsulates the following information:

- **Policy Persons** – While creating a fully-insured policy, you need to associate the person who is the main customer of the policy. While associating a person with a fully-insured policy, you need to specify the policy person role which indicates the role of the person in the policy. For example, whether the person associated with the policy is the policy holder, broker, or underwriter. You can associate multiple persons with a fully-insured policy using the same or different policy person role. However, at a time, only one person can be the main customer of the policy.
- **Policy Plans** – You can define one or more plans in a fully-insured policy. For example, Medical, Dental, Medicare, and Disability plans. While defining a policy plan, you need to specify either a price item or at least one pricing rule type. The price item given in the policy plan is used to create a pass-through billable charge for pre-calculated premium amount which is received in a health care inbound message.

Alternatively, you can associate a pricing rule type with a policy plan. You can only associate a pricing rule type where the pricing rule type category is set to **Age Based**, **Tier Based**, or **Pass-Through Billable Charge**. If you associate an age based pricing rule type with the policy plan, the system creates the SQI based billable charge whenever the membership premium is calculated for eligible members. If you associate a tier based pricing rule type with the policy plan, the system creates the SQI based billable charge whenever the premium is calculated for membership. However, if you associate a pass-through billable charge pricing rule type with the policy plan, the system creates an SQI based billable charge using the pass-through billable charge pricing rule type whenever the price item information is given, but the account information is not given in a health care inbound message. Note that if both the price item and account details are given in the billable charge information of a health care inbound message, the system directly creates the SQI based billable charge for the pre-calculated premium and does not refer to the pass-through billable charge pricing rule type which is associated with the policy plan.

- **Membership** – You can define one or more memberships in a policy plan. While defining a membership, you need to specify the plan for which you want to create the membership, the person who is the main subscriber of the membership, and how the main subscriber is related to the membership. Once the membership is created, you can add more members (i.e. persons) to the membership, if required. You can inactivate a membership whenever required. On terminating a policy, the system automatically terminates the membership.



- **Member Persons** – While adding a person to a membership, you need to specify whether the person is the main subscriber of the membership, whether the person is financially responsible for the membership, and how the person is related to the main subscriber. At a time, only one person can be the main subscriber of the membership. You cannot remove a member person, who is the main subscriber, from the membership. You can inactivate a member person whenever required. If you inactivate a member person who is the main subscriber, the system automatically inactivates the membership and all other member persons which are included in the membership.
- **Membership Contracts** – You can associate one or more contracts with a membership. At present, the system uses the contract created for a policy plan on the accounts of the parent customer or bill group for billing the respective membership premium. The system does not use the membership contracts for billing the membership premium.
- **Policy Plan Contracts** – The system creates or updates contracts of a policy plan when you do either of the following:
  - Create or Edit a Policy Plan from the User Interface or through an Inbound Message
  - Create or Edit an Account from the User Interface or through an Inbound Message

The system uses the contract created for a policy plan on the accounts of the parent customer or bill group for billing the respective membership premium. For more information, refer to [Fully-Insured Policy Plan Contract Creation](#) on page 2027.

On defining a fully-insured policy, the status of the policy is set to **Pending**. You can then edit, delete or activate a policy. Once a fully-insured policy is activated, you can terminate, reinstate, or renew the policy whenever required.

### Fully-Insured Policy Activation

You can activate a fully-insured policy by clicking the **Activate** button in the **Policy** screen. On activating a fully-insured policy, the status of the policy is set to **In Force/Active**.

**Note:** If a fully-insured policy is created through a customer registration object or a health care inbound message, the status of the policy is directly set to **In Force/Active**

Once a fully-insured policy is activated, you can terminate, reinstate, or renew the policy whenever required.

### Fully-Insured Policy Termination

The system enables you to terminate a fully-insured policy whenever required. There are two ways in which you can terminate a fully-insured policy:

- **Initiate Policy Termination Process** – In this method, you can initiate the policy termination process from the user interface. To initiate the termination process, you need to specify the termination date and termination reason. On initiating the termination process, the status of the policy is changed to **Pending Termination**. In addition, the system creates an outbound message which request for confirmation whether the policy should be terminated. This outbound message can be sent to the policy processing system via custom mechanism. On receiving confirmation from the policy processing system through a health care inbound message, the system changes the status of the policy to **Terminated**.
- **Terminate Policy** – In this method, you can directly terminate a fully-insured policy. To terminate a fully-insured policy, you need to specify the termination reason. You can directly terminate the policy from the user interface or through a health care inbound message. On clicking the **Terminate** button, the system will terminate the fully-insured policy on the system date. However, when you terminate a fully-insured policy through a health care inbound message, the policy is terminated when the health care inbound message is processed in the system. On terminating a fully-insured policy, the status of the policy is changed to **Terminated**.

Once the status of the policy is changed to **Terminated**, the system sets the end date of the following entities to the termination date when the respective condition is met:

- Policy (when the termination date is not earlier than the policy start date or later than the policy end date)
- Policy Person (when the termination date falls within the date range in which the person is associated with the policy)

**Note:** The system does not consider those persons associated with policy whose start date is later than the termination date or whose end date is earlier than the termination date.

- Policy Plan (when the termination date falls within the date range of the policy plan)

**Note:** The system does not consider those policy plans whose start date is later than the termination date or whose end date is earlier than the termination date.

- Membership (when the termination date falls within the date range of the membership)

**Note:** The system does not consider those memberships whose start date is later than the termination date or whose end date is earlier than the termination date.

- Member Person (when the termination date falls within the date range in which the person is associated with the membership)

**Note:** The system does not consider those member persons whose start date is later than the termination date or whose end date is earlier than the termination date.

- Contracts Associated with the Membership (when the termination date falls within the date range of the contract)

**Note:** The system does not consider those contracts whose start date is later than the termination date or whose end date is earlier than the termination date.

The system also changes the status of all memberships to **Terminated** irrespective of whether it is effective on the termination date or not. On terminating a membership, the system creates an audit event for the membership. For each audit event, the system identifies the policy plan to which the membership belongs and the active pricing rules defined on the policy plan. It then identifies the pricing rule types using which these active pricing rules are created in the system. An entry for each membership, pricing rule type, and effective date combination is created in the **Pending (P)** status in the **CI\_REPRC\_ENTITY\_DTL** table. For more information, see [Audit Framework for Fully-Insured Health Care Billing](#) on page 2834.

### Fully-Insured Policy Reinstatement

The system enables you to reinstate the terminated policy whenever required. There are two ways in which you can reinstate a fully-insured policy:

- **Initiate Policy Reinstatement Process** – In this method, you can initiate the policy reinstatement process from the user interface. To initiate the reinstatement process, you need to specify the reinstatement reason. On initiating the reinstatement process, the status of the policy is changed to **Pending Reinstatement**. In addition, the system creates an outbound message which request for confirmation whether the policy should be reinstated. This outbound message can be sent to the policy processing system via custom mechanism. On receiving confirmation from the policy processing system through a health care inbound message, the system changes the status of the policy to **Reinstated**.
- **Reinstate Policy** – In this method, you can directly reinstate a fully-insured policy. To reinstate a fully-insured policy, you need to specify the reinstatement reason. You can directly reinstate the policy from the user interface or through a health care inbound message. On clicking the **Reinstate** button, the system will reinstate the fully-insured policy on the system date. However, when you reinstate a fully-insured policy through a health care inbound message, the policy is reinstated when the health care inbound message is processed in the system. On reinstating a fully-insured policy, the status of the policy is changed to **Reinstated**.

Once the status of the policy is changed to **Reinstated**, the system updates the end date of the following entities to the respective original end date:

- Policy
- Policy Person
- Policy Plan

- Membership
- Member Person
- Contracts Associated with the Membership

**Note:**

The system stores the original end date of the above listed entities when you define or edit a policy, policy plan, or membership.

Here, the assumption is that the pass-through billable charges information for the membership will be sent again through an inbound message along with the reinstatement reason. And, therefore the exiting billable charges will not be extended.

Finally, the system automatically transitions the fully-insured policy from **Reinstated** to **In Force/Active**.

**Fully-Insured Policy Renewal**

You can renew a fully-insured policy only through a health care inbound message and not from the user interface. If you want to renew a fully-insured policy, you must send the renewal date along with the new policy end date through a health care inbound message. On processing the health care inbound message, the fully-insured policy is renewed. The renewal date is stamped on the fully-insured policy. The policy end date is extended as mentioned in the health care inbound message. The policy plan and membership information for the renewed period must be sent in the subsequent health care inbound messages.

**Note:** You can renew a fully-insured policy only when it is in the **In Force/Active** status.

**Fully-Insured Policy Plan Contract Creation**

The system automatically creates a contract for a fully-insured policy plan on the parent customer and/or bill group accounts. Depending on the account for which the billable charge is created, the system uses the respective contract for billing the membership premium. The system creates or updates contracts of a policy plan when you do either of the following:

- **Create or Edit a Policy Plan from the User Interface or through an Inbound Message** – The system creates a contract in either of the following ways:
  - If a price item is associated with the policy plan, it creates a contract using the contract type which is associated with the price item.
  - If a pricing rule type is associated with the policy plan and the pricing rule type contains one or more price items, it creates a contract using a distinct contract type which is associated with each price item.

Let us assume that PRT1 is associated with the policy plan and it contains three price items – P1, P2, and P3. Now, if the P1 is associated with the CT1 contract type, P2 is associated with the CT2 contract type, and P3 is associated with the CT3 contract type, the system will create three contracts - C1 using CT1, C2 using CT2, and C3 using CT3. However, if the P1 and P3 are associated with the CT1 contract type and P2 is associated with the CT2 contract type, the system will create two distinct contracts - C1 using CT1 and C2 using CT2.

If multiple pricing rule types are associated with the policy plan and each pricing rule type contains multiple price items, it creates a contract using a distinct contract type which is associated with each price item on each pricing rule type. Let us assume that PRT1 and PRT2 are associated with the policy plan, PRT1 contains three price items – P1, P2, and P3, and PRT2 contains three price items – P1, P4, and P5. Now, if the P1 is associated with the CT1 contract type, P2 is associated with the CT2 contract type, P3 is associated with the CT3 contract type, P4 is associated with the CT4 contract type, and P5 is associated with the CT5 contract type, the system will create five contracts - C1 using CT1, C2 using CT2, C3 using CT3, C4 using CT4, and C5 using CT5. However, if P1, P2, and P5 are associated with the CT1 contract type and P3 and P4 are associated with the CT2 contract type, the system will create two distinct contracts - C1 using CT1 and C2 using CT2.

The status of each contract is set to **Active**. The contract start date is set to the start date of the respective plan. If the same contract type is associated with the same or different price items on the same or different pricing rule types of different plans, the contract start date is set to the start date of the earliest plan. The default rate schedule specified on the respective contract type is added to the contract in the rate information and its effective date is set to the contract start date.

If the policy plan belongs to an individual policy of the parent customer (i.e. a policy where a bill group is not associated), the system will create contracts of distinct contract types for each account of the parent customer and bill groups. Let us assume that...

- PC1 has two bill groups – BG1 and BG2
- PC1 has A1 account, BG1 has A2 account, and BG2 has A3 and A4 accounts
- An individual policy named P1 with two plans – PP1 and PP2 - is created for PC1
- PP1 (with the start date as 01-01-2019) is associated with PRT1 and PRT2
- PP2 (with the start date as 03-01-2019) is associated with PRT2 and PRT3
- PRT1 contains two price items – PI1 and PI2
- PRT2 contains three price items – PI1, PI3, and PI4
- PRT3 contains three price items – PI4, PI5, and PI6
- PI1 is associated with the CT1 contract type, PI2 is associated with the CT2 contract type, PI3 is associated with the CT3 contract type, PI4 and PI5 are associated with the CT4 contract type, and PI6 is associated with the CT6 contract type

Now, in such case, the system will create five distinct contracts – C1 using CT1, C2 using CT2, C3 using CT3, C4 using CT4, and C6 using CT6 – on the A1, A2, A3, and A4 accounts. In this example, the start date is derived in the following manner:

Price Item	Contract Type	Contract	Plans for which the contract is created...	Earliest Plan Date (i.e. Contract Start Date)
PI1	CT1	C1	PP1 (01-01-2019) and PP2 (03-01-2019)	01-01-2019
PI2	CT2	C2	PP1 (01-01-2019)	01-01-2019
PI3	CT3	C3	PP1 (01-01-2019) and PP2 (03-01-2019)	01-01-2019
PI4	CT4	C4	PP1 (01-01-2019) and PP2 (03-01-2019)	01-01-2019
PI5	CT4	C4	PP2 (03-01-2019)	01-01-2019 (because PI4 and PI5 are associated with the same contract type (i.e. CT4))
PI6	CT6	C6	PP2 (03-01-2019)	03-01-2019

The following figure graphically illustrates the above example:

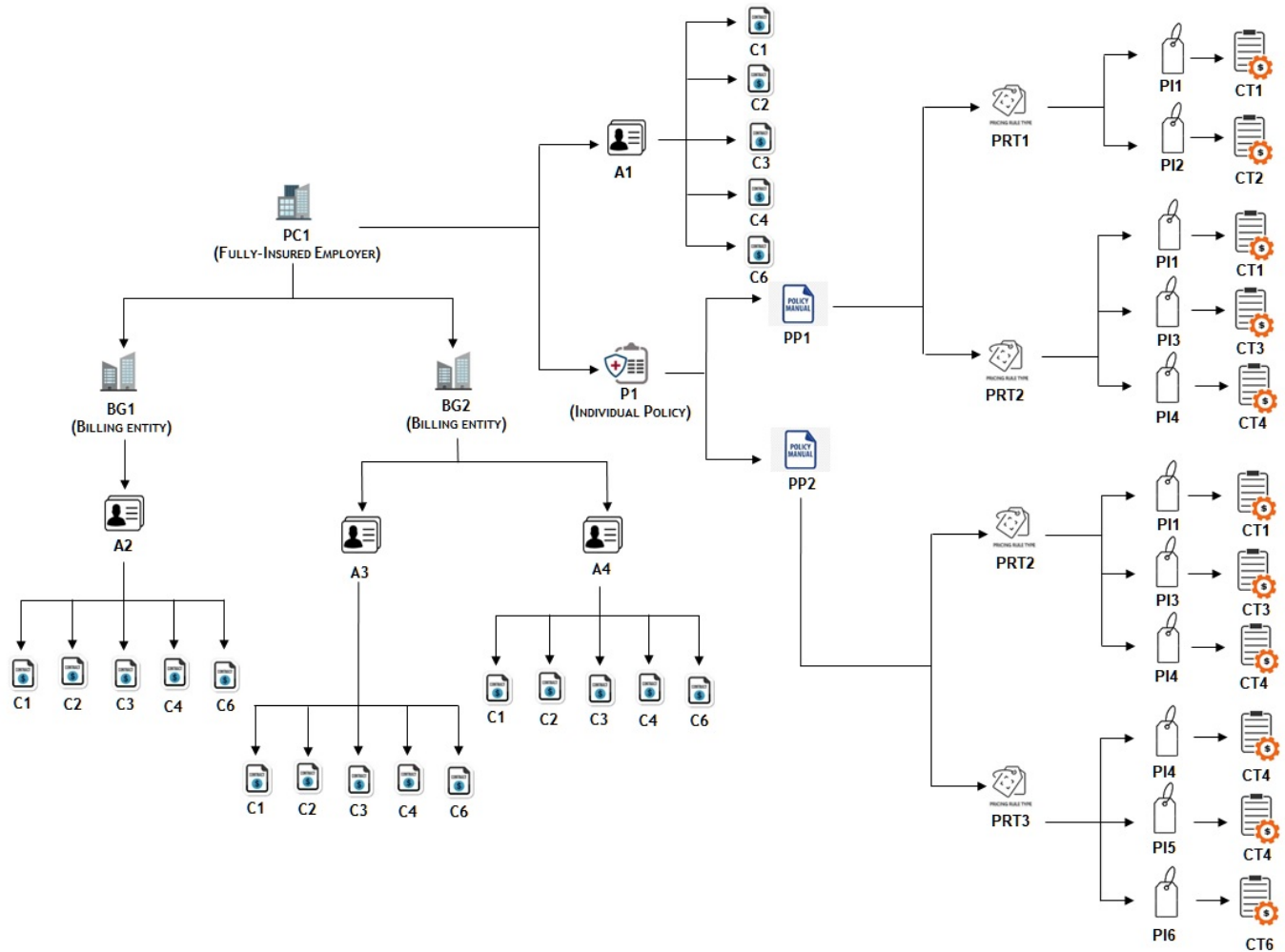

However, if the policy plan belongs to a policy of a bill group (where the parent customer is the policy holder), the system will create contracts of distinct contract types for each account of the parent customer and the bill group. Let us assume that...

- PC1 has two bill groups – BG1 and BG2
- PC1 has A1 account, BG1 has A2 account, and BG2 has A3 and A4 accounts
- A policy named P1 with three plans – PP1, PP2, and PP3 – is created for BG1 (where PC1 is the policy holder)
- PP1 (with the start date as 01-01-2019) is associated with PRT1 and PRT2
- PP2 (with the start date as 03-01-2019) is associated with PRT2 and PRT3
- PP3 (with the start date as 06-01-2019) is associated with PRT1
- PRT1 contains two price items – PI1 and PI2
- PRT2 contains three price items – PI1, PI3, and PI4
- PRT3 contains three price items – PI4, PI5, and PI6
- PI1 is associated with the CT1 contract type, PI2 is associated with the CT2 contract type, PI3 is associated with the CT3 contract type, PI4 and PI5 are associated with the CT4 contract type, and PI6 is associated with the CT6 contract type

Now, in such case, the system will create five distinct contracts – C1 using CT1, C2 using CT2, C3 using CT3, C4 using CT4, and C6 using CT6 – on the A1 and A2 accounts. The start date is derived in the following manner:

<b>Price Item</b>	<b>Contract Type</b>	<b>Contract</b>	<b>Plans for which the contract is created...</b>	<b>Earliest Plan Date (i.e. Contract Start Date)</b>
PI1	CT1	C1	PP1 (01-01-2019), PP2 (03-01-2019), and PP3 (06-01-2019)	01-01-2019
PI2	CT2	C2	PP1 (01-01-2019) and PP3 (06-01-2019)	01-01-2019
PI3	CT3	C3	PP1 (01-01-2019) and PP2 (03-01-2019)	01-01-2019
PI4	CT4	C4	PP1 (01-01-2019) and PP2 (03-01-2019)	01-01-2019
PI5	CT4	C4	PP2 (03-01-2019)	01-01-2019 (because PI4 and PI5 are associated with the same contract type (i.e. CT4))
PI6	CT6	C6	PP2 (03-01-2019)	03-01-2019

The following figure graphically illustrates the above example:

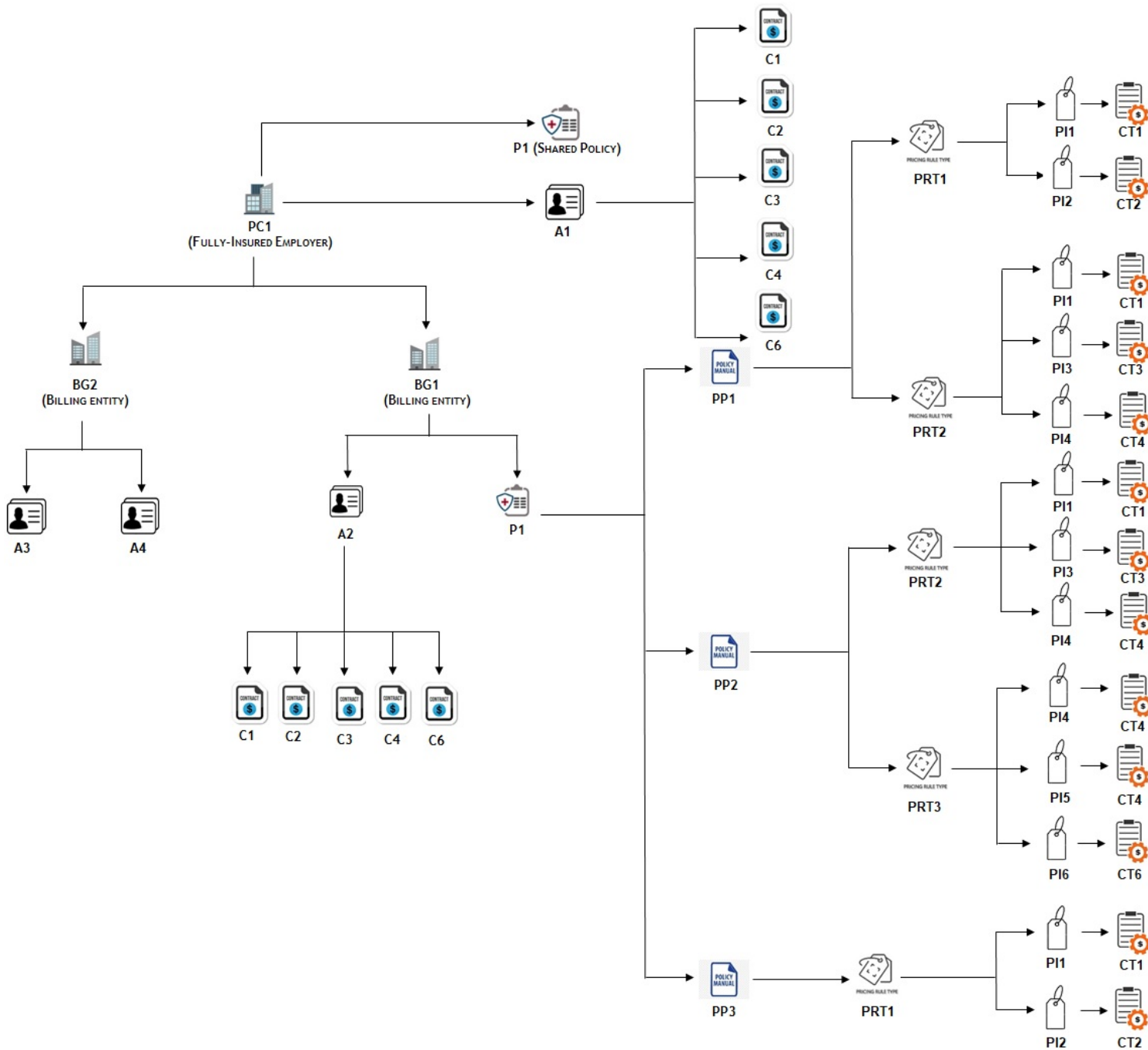

**Note:**

The system creates a contract using a contract type for an account only when the division to which the account and contract type belongs is same.

If a contract of a contract type is already present on the account, the system will not create a new contract. Instead, it will update the start date of the existing contract, if required.

The contract start date is set to the start date of the earliest plan across policies when the same contract type is associated with the same or different price items on the same or different pricing rule types of different plans on different policies.

- **Create or Edit an Account from the User Interface or through an Inbound Message** – The system creates a contract when either of the following condition is met:
  - The main customer of the account is a parent customer and holds an individual policy (i.e. a policy where a bill group is not associated) which is created using the policy type where the policy category is set to **Fully-Insured Individual** or **Fully-Insured Group**.
  - The main customer of the account is a parent customer and holds a shared policy (i.e. a policy where a bill group is associated) which is created using the policy type where the policy category is set to **Fully-Insured Individual** or **Fully-Insured Group**.
  - The main customer of the account is a bill group and holds a shared policy (i.e. a policy where the parent customer is the policy holder) which is created using the policy type where the policy category is set to **Fully-Insured Individual** or **Fully-Insured Group**.

The system creates a contract in either of the following ways:

- If a price item is associated with the policy plan, it creates a contract using the contract type which is associated with the price item.
- If a pricing rule type is associated with the policy plan and the pricing rule type contains one or more price items, it creates a contract using a distinct contract type which is associated with each price item.

Let us assume that PRT1 is associated with the policy plan and it contains three price items – P1, P2, and P3. Now, if the P1 is associated with the CT1 contract type, P2 is associated with the CT2 contract type, and P3 is associated with the CT3 contract type, the system will create three contracts - C1 using CT1, C2 using CT2, and C3 using CT3. However, if the P1 and P3 are associated with the CT1 contract type and P2 is associated with the CT2 contract type, the system will create two distinct contracts - C1 using CT1 and C2 using CT2.

If multiple pricing rule types are associated with the policy plan and each pricing rule type contains multiple price items, it creates a contract using a distinct contract type which is associated with each price item on each pricing rule type. Let us assume that PRT1 and PRT2 are associated with the policy plan, PRT1 contains three price items – P1, P2, and P3, and PRT2 contains three price items – P1, P4, and P5. Now, if the P1 is associated with the CT1 contract type, P2 is associated with the CT2 contract type, P3 is associated with the CT3 contract type, P4 is associated with the CT4 contract type, and P5 is associated with the CT5 contract type, the system will create five contracts - C1 using CT1, C2 using CT2, C3 using CT3, C4 using CT4, and C5 using CT5. However, if P1, P2, and P5 are associated with the CT1 contract type and P3 and P4 are associated with the CT2 contract type, the system will create two distinct contracts - C1 using CT1 and C2 using CT2.

The status of each contract is set to **Active**. The contract start date is set to the start date of the respective plan. If the same contract type is associated with the same or different price items on the same or different pricing rule types of different plans on different policies, the contract start date is set to the start date of the earliest plan across policies. The default rate schedule specified on the respective contract type is added to the contract in the rate information and its effective date is set to the contract start date.

If you create an account for a parent customer who holds both individual and shared policies, the system will create contracts of distinct contract types for all parent customer's policies on the account. Let us assume...

- PC1 has two bill groups – BG1 and BG2
- PC1 has two policies – an individual policy named P1 (where a bill group is not associated) and a shared policy named P2 (where BG1 is associated)
- BG1 has one policy named P2 where PC1 is the policy holder
- An account named A1 is added for PC1
- P1 has two plans – PP1 and PP2
- P2 has two plans – PP11 and PP12
- PP1 (with the start date as 01-01-2019) is associated with PRT1 and PRT2



- PP2 (with the start date as 06-01-2019) is associated with PRT2, PRT3, and PRT4
- PP11 (with the start date as 05-01-2019) is associated with PRT111 and PRT112
- PP12 (with the start date as 09-01-2019) is associated with PRT113 and PRT114
- PRT1 contains two price items – PI1 and PI2
- PRT2 contains two price items – PI3 and PI4
- PRT3 contains two price items – PI1 and PI5
- PRT4 contains two price items – PI6 and PI7
- PRT111 contains two price items – PI11 and PI12
- PRT112 contains two price items – PI1 and PI5
- PRT113 contains two price items – PI13 and PI14
- PRT114 contains two price items – PI7 and PI15
- PI1 is associated with the CT1 contract type, PI2 and PI3 are associated with the CT2 contract type, PI4 is associated with the CT4 contract type, PI5 is associated with the CT5 contract type, PI6 is associated with the CT6 contract type, PI7 is associated with the CT7 contract type, PI11 is associated with the CT11 contract type, PI12 is associated with the CT12 contract type, PI13 is associated with the CT13 contract type, PI14 is associated with the CT14 contract type, and PI15 is associated with the CT15 contract type

Now, in such case, the system will create eleven distinct contracts – C1 using CT1, C2 using CT2, C4 using CT4, C5 using CT5, C6 using CT6, C7 using CT7, C11 using CT11, C12 using CT12, C13 using CT13, C14 using CT14, and C15 using CT15 – on the A1 account. In this example, the start date is derived in the following manner:

Price Item	Contract Type	Contract	Plans for which the contract is created...	Earliest Plan Date (i.e. Contract Start Date)
PI1	CT1	C1	PP1 (01-01-2019), PP2 (06-01-2019), and PP11 (05-01-2019)	01-01-2019
PI2	CT2	C2	PP1 (01-01-2019)	01-01-2019
PI3	CT2	C2	PP1 (01-01-2019) and PP2 (06-01-2019)	01-01-2019
PI4	CT4	C4	PP1 (01-01-2019) and PP2 (06-01-2019)	01-01-2019
PI5	CT5	C5	PP2 (06-01-2019) and PP11 (05-01-2019)	05-01-2019
PI6	CT6	C6	PP2 (06-01-2019)	06-01-2019
PI7	CT7	C7	PP2 (06-01-2019) and PP12 (09-01-2019)	06-01-2019
PI11	CT11	C11	PP11 (05-01-2019)	05-01-2019
PI12	CT12	C12	PP11 (05-01-2019)	05-01-2019
PI13	CT13	C13	PP12 (09-01-2019)	09-01-2019

Price Item	Contract Type	Contract	Plans for which the contract is created...	Earliest Plan Date (i.e. Contract Start Date)
PI14	CT14	C14	PP12 (09-01-2019)	09-01-2019
PI15	CT15	C15	PP12 (09-01-2019)	09-01-2019

The following figure graphically illustrates the above example:

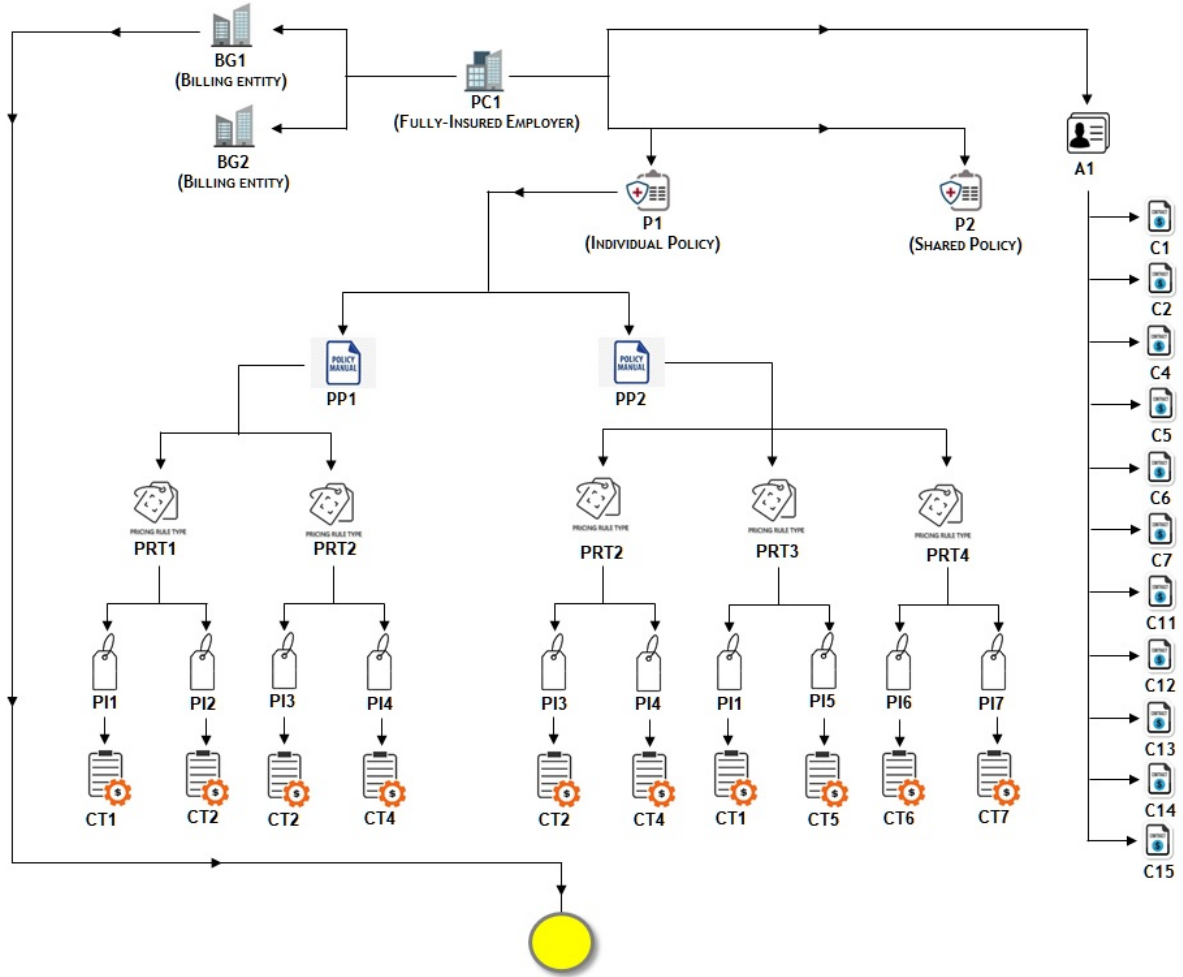

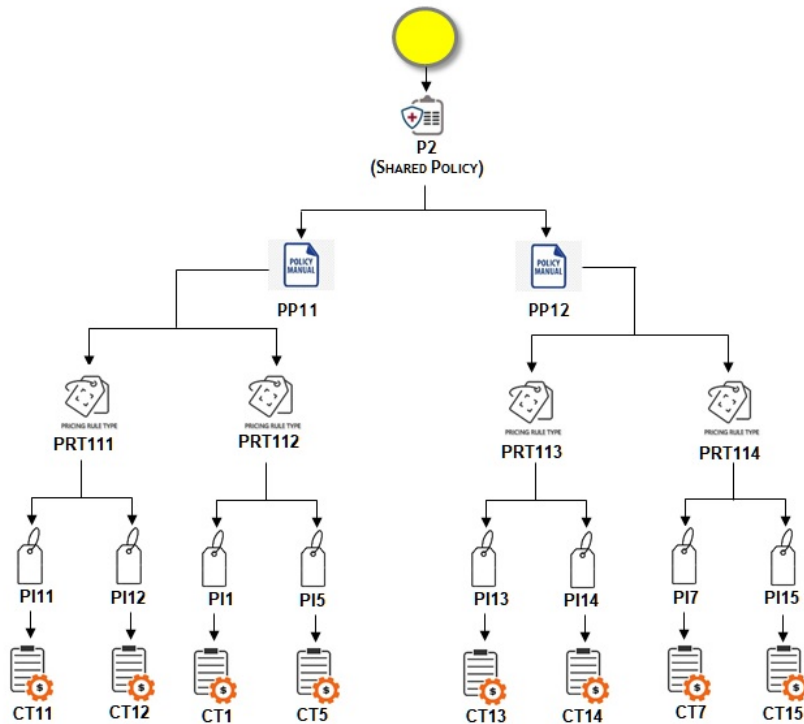

If you create an account for a bill group who holds a shared policy and its parent customer holds both individual and shared policies, the system will create contracts of distinct contract types for the bill group's shared policies and parent customer's individual policies on the account. Let us assume...

- PC1 has two bill groups – BG1 and BG2
- PC1 has two policies – an individual policy named P2 (where a bill group is not associated) and a shared policy named P1 (where BG2 is associated)
- BG2 has one policy named P1 where PC1 is the policy holder
- An account named A1 is added for BG2
- P1 has two plans – PP11 and PP12
- P2 has two plans – PP1 and PP2
- PP1 (with the start date as 01-01-2019) is associated with PRT1 and PRT2
- PP2 (with the start date as 04-01-2019) is associated with PRT3 and PRT4
- PP11 (with the start date as 07-01-2019) is associated with PRT11 and PRT12
- PP12 (with the start date as 11-01-2019) is associated with PRT13 and PRT14
- PRT1 contains two price items – PI1 and PI2
- PRT2 contains two price items – PI3 and PI2
- PRT3 contains two price items – PI3 and PI4
- PRT4 contains two price items – PI5 and PI6
- PRT11 contains two price items – PI111 and PI112
- PRT12 contains two price items – PI1 and PI6
- PRT13 contains two price items – PI113 and PI114

- PRT14 contains two price items – PI15 and PI5
- PI1 is associated with the CT1 contract type, PI2 and PI3 are associated with the CT2 contract type, PI4 is associated with the CT4 contract type, PI5 is associated with the CT5 contract type, PI6 is associated with the CT6 contract type, PI111 is associated with the CT111 contract type, PI112 is associated with the CT112 contract type, PI113 is associated with the CT113 contract type, and PI114 and PI115 is associated with the CT114 contract type

Now, in such case, the system will create nine distinct contracts – C1 using CT1, C2 using CT2, C4 using CT4, C5 using CT5, C6 using CT6, C111 using CT111, C112 using CT112, C113 using CT113, and C114 using CT114 – on the A1 account. In this example, the start date is derived in the following manner:

Price Item	Contract Type	Contract	Plans for which the contract is created...	Earliest Plan Date (i.e. Contract Start Date)
PI1	CT1	C1	PP1 (01-01-2019) and PP11 (07-01-2019)	01-01-2019
PI2	CT2	C2	PP1 (01-01-2019)	01-01-2019
PI3	CT2	C2	PP1 (01-01-2019) and PP2 (04-01-2019)	01-01-2019
PI4	CT4	C4	PP2 (04-01-2019)	04-01-2019
PI5	CT5	C5	PP2 (04-01-2019) and PP12 (11-01-2019)	04-01-2019
PI6	CT6	C6	PP2 (04-01-2019) and PP11 (07-01-2019)	04-01-2019
PI111	CT111	C111	PP11 (07-01-2019)	07-01-2019
PI112	CT112	C112	PP11 (07-01-2019)	07-01-2019
PI113	CT113	C113	PP12 (11-01-2019)	11-01-2019
PI114	CT114	C114	PP12 (11-01-2019)	11-01-2019
PI115	CT114	C114	PP12 (11-01-2019)	11-01-2019

The following figure graphically illustrates the above example:

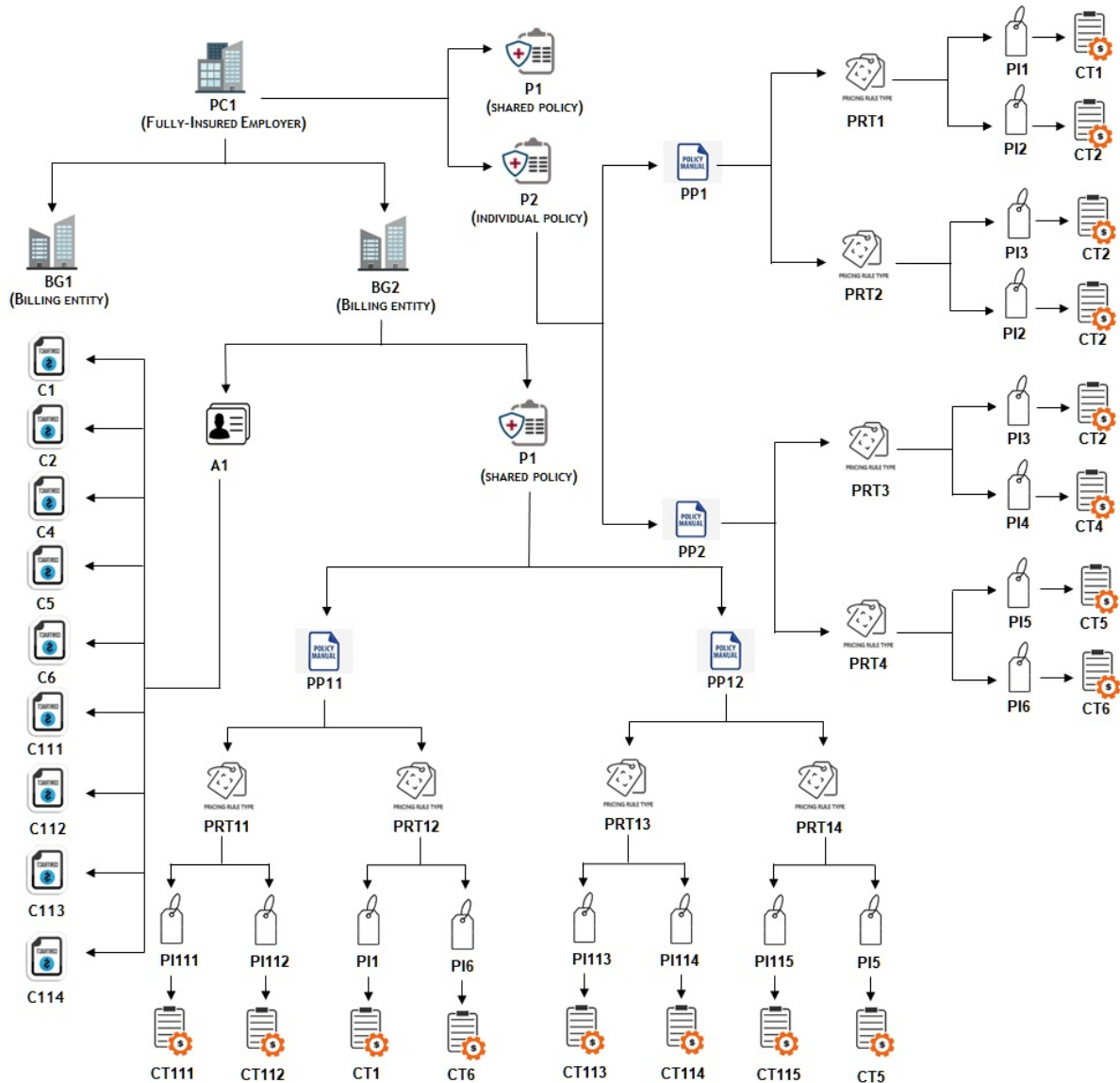
**Note:**

The system creates a contract using a contract type for an account only when the division to which the account and contract type belongs is same.

If a contract of a contract type is already present on the account, the system will not create a new contract. Instead, it will update the start date of the existing contract, if required.

**Self-Funded Policy**

You can create a self-funded policy using a policy type where the policy category is set to **Self-Funded**. The policy type indicates the business object using which the self-funded policy should be created in the system.

As per the self-funded health care business, the system enables you to create a self-funded policy for a bill group where the parent customer is the policy holder. You can create or edit a self-funded policy from the **Policy** screen. In addition,

you can create or edit a self-funded policy through a customer registration object or a health care inbound message. If the self-funded policy information is given for a bill group in a health care inbound message, the system does the following:

- Associates the bill group with the policy using the policy person role which is specified in the **Bill Group Policy Person Role** option type of the **C1-ASOBLLNG** feature configuration
- Associates the parent customer with the policy using the policy person role which is specified in the **Parent Customer Policy Person Role** option type of the **C1-ASOBLLNG** feature configuration

A self-funded policy encapsulates the following information:

- **Policy Persons** – While creating a self-funded policy, you need to associate the person who is the main customer of the policy. While associating a person with a self-funded policy, you need to specify the policy person role which indicates the role of the person in the policy. For example, whether the person associated with the policy is the policy holder, broker, or underwriter. You can associate multiple persons with a self-funded policy using the same or different policy person role. However, at a time, only one person can be the main customer of the policy.
- **Policy Contracts** – The system creates a contract for a self-funded policy when the policy is created either from the user interface or through an inbound message. For more information, refer to [Self-Funded Policy Contract Creation](#) on page 2041.

On defining a self-funded policy, the status of the policy is set to **Pending**. You can then edit, delete or activate a policy. Once a self-funded policy is activated, you can renew the policy whenever required.

**Note:** If a self-funded policy is created through a customer registration object or a health care inbound message, the status of the policy is set to **Pending**.

In a self-funded policy, you can specify the policy period as well as the runout period. Here, the policy period means the period between the policy start and end dates when the policy is active. And, the runout period means the period between the runout start and end dates when the policy is no more active. Note that the system sets the runout start date to the policy end date + 1 Day when you specify the runout end date.

The system enables you to create a self-funded policy for the following contract types which are used in the self-funded health care business:

Contract Type	Policy (Example)	Policy Period (i.e. Period when Policy will be in the Active Status)	Runout Period (i.e. Period when Policy will be in the Runout Status)	Comments
<b>12/12</b> (Claims Incurred and Paid During the Policy Period)	P1	01-01-2019 to 12-31-2019	-	Here, you will not specify the runout end date for the self-funded policy (i.e. P1).
<b>12/15</b> (Claims Incurred During the Policy Period and Paid During the Policy and Runout Periods)	P2	01-01-2019 to 12-31-2019	01-01-2020 to 03-31-2020	Here, the runout period is derived only when you set the runout end date of the self-funded policy (i.e. P2) to 03-31-2020.

Contract Type	Policy (Example)	Policy Period (i.e. Period when Policy will be in the Active Status)	Runout Period (i.e. Period when Policy will be in the Runout Status)	Comments
<b>12/18</b> (Claims Incurred During the Policy Period and Paid During the Policy and Runout Periods)	P3	01-01-2019 to 12-31-2019	01-01-2020 to 06-30-2020	Here, the runout period is derived only when you set the runout end date of the self-funded policy (i.e. P3) to 06-30-2020.
<b>15/12</b> (Claims Incurred Three Months Prior to the Policy Start Date and During the Policy Period and Paid During the Policy Period)	P4	01-01-2019 to 12-31-2019	-	Here, you will not specify the runout end date for the self-funded policy (i.e. P4).

The system enables you to offer different pricing for different policy periods, such as active, runout, and post runout.

### Self-Funded Policy Activation

A self-funded policy can be activated manually from the user interface or through the **Policy Periodic Monitor (C1-POLPR)** batch. You can activate a self-funded policy by clicking the **Activate** button in the **Policy** screen. On clicking the **Activate** button, the system checks whether the To Do created for the **Pending** status is completed. If the To Do created for the **Pending** status is not completed, it completes the To Do and then changes the status of the self-funded policy from **Pending** to **In Force/Active**.

**Note:** The status of the policy is not changed from **Pending** to **In Force/Active** until the system date is later than or equal to the policy start date.

On executing the **Policy Periodic Monitor (C1-POLPR)** batch, the system does the following:

- If the self-funded policy is in the **Pending** status and the policy start date - X days is earlier than or equal to the system date, it creates a To Do using the To Do type which is specified in the **To Do Type for Pending Status** parameter (of an algorithm created using the **C1-ASOPOLMOA** algorithm type).
- If the start date of the self-funded policy is earlier than or equal to the system date and the To Do created using the To Do type specified in the **To Do Type for Pending Status** parameter is completed, it changes the status of the self-funded policy from **Pending** to **In Force/Active**.

You can define pricing rules using the pricing rule types of the following categories for a self-funded policy of a bill group which is in the **Active** status:

- Claim
- Specific Stop-Loss
- Aggregate Stop-Loss
- Retention Type Claim Based
- Retention Type Enrollment Based
- Ancillary
- Flat Fees
- Level Funded

### Transition of Self-Funded Policy to Runout Status

A self-funded policy can be transitioned to the **Runout** status from the user interface or through the **Policy Periodic Monitor (C1-POLPR)** batch. You can transition a self-funded policy to the **Runout** status by clicking the **Runout** button in the **Policy** screen. On clicking the **Runout** button, the system checks whether the To Do created for the **In Force/Active** status is completed. If the To Do created for the **In Force/Active** status is not completed, it completes the To Do and then changes the status of the self-funded policy from **In Force/Active** to **Runout**.

**Note:** The status of the policy is not changed from **In Force/Active** to **Runout** when either of the following condition is met:

- The runout end date is not specified.
- The system date is earlier than or equal to the policy end date.
- The policy is renewed.

On executing the **Policy Periodic Monitor (C1-POLPR)** batch, the system does the following:

- If the self-funded policy is in the **In Force/Active** status and the policy end date - X days is earlier than or equal to the system date, it creates a To Do using the To Do type which is specified in the **To Do Type for Active Status** parameter (of an algorithm created using the **C1-ASOPOLMOA** algorithm type).
- If the end date of the self-funded policy is earlier than or equal to the system date and the To Do created using the To Do type specified in the **To Do Type for Active Status** parameter is completed, it changes the status of the self-funded policy from **In Force/Active** to **Runout**.

You can define pricing rules using the pricing rule types of the following categories for a self-funded policy of a bill group which is in the **Runout** status:

- Claim
- Specific Stop-Loss
- Aggregate Stop-Loss
- Retention Type Claim Based
- Ancillary
- Flat Fees
- Level Funded

### Transition of Self-Funded Policy to Post Runout Status

A self-funded policy can be transitioned to the **Post Runout** status only through the **Policy Periodic Monitor (C1-POLPR)** batch. On executing the **Policy Periodic Monitor (C1-POLPR)** batch, the system does the following:

- If the self-funded policy is in the **Runout** status and the runout end date - X days is earlier than or equal to the system date, it creates a To Do using the To Do type which is specified in the **To Do Type for Runout Status** parameter (of an algorithm created using the **C1-ASOPOLMOA** algorithm type).
- If the runout end date of the self-funded policy is earlier than or equal to the system date and the To Do created using the To Do type specified in the **To Do Type for Runout Status** parameter is completed, it changes the status of the self-funded policy from **Runout** to **Post Runout**.

You can define pricing rules using the pricing rule types of the following categories for a self-funded policy of a bill group which is in the **Post Runout** status:

- Claim
- Specific Stop-Loss
- Aggregate Stop-Loss



- Retention Type Claim Based
- Ancillary

### Self-Funded Policy Renewal

You can renew a self-funded policy which is associated with a bill group. However, note that you can renew a self-funded policy only when it is in the **In Force/Active** status and which is not yet renewed. You can renew a self-funded policy only from the user interface and not through a health care inbound message.

On renewing a self-funded policy, a new policy is created in the **Pending** status. The renewal date is stamped in the base policy. The information from the base policy is copied to the renewed policy. The start date of the renewed policy is set to the base policy's end date plus one day. For example, if the base policy's end date is 12-31-2018, then by default, the renewed policy's start date is set to 01-01-2019.

While renewing a self-funded policy, you cannot disassociate persons (from the renewed policy) who are associated with the base policy using a policy person role which is specified in the **Bill Group Policy Person Role** or **Parent Customer Policy Person Role** option type of the **C1-ASOBLLNG** feature configuration.

While renewing a self-funded policy, the system enables you to copy the following pricing rules of the base policy and thereby create new pricing rules for the renewed policy:

- Claim
- Retention Type Claim Based
- Retention Type Enrollment Based
- Recurring Flat Fees
- Ancillary

While copying a pricing rule, the start and end dates of the new pricing rule are set to the renewed policy's start and end dates, respectively. If there are multiple pricing rules which are created using the same pricing rule type and are effective for the different date range, the system copies only one pricing rule from the base policy with the latest date range.

Once a policy is renewed, you cannot edit the base policy's end date or manually change the status of the base policy to **Runout**. The system automatically changes the status of the base policy to **Runout** when the status of the latest renewed policy is changed to **Runout**.

### Self-Funded Policy Contract Creation

The system automatically creates contracts when a self-funded policy is created either from the user interface or through a health care inbound message. It creates a contract for a self-funded policy on each account of the bill group. It creates a contract using the contract type which is specified in the **Contract Type** parameter of an algorithm which is created using the **C1-ASOBOPOSP** algorithm type. Let us assume that the **Contract Type** parameter in the **C1-ASOBOPOSP** algorithm is set to CT1. Now, when you create the self-funded policies named P1 and P2 for BG1 and P11, P12, and P13 for BG2 through a health care inbound message, the system will create the following contracts on the respective accounts:

Bill Group	Account	Contract
BG1	A1	C1 (for P1 using the CT1 contract type)
		C2 (for P2 using the CT1 contract type)
	A2	C3 (for P1 using the CT1 contract type)
		C4 (for P2 using the CT1 contract type)
BG2	A4	C11 (for P11 using the CT1 contract type)
		C12 (for P12 using the CT1 contract type)

Bill Group	Account	Contract
	A5	C13 (for P13 using the CT1 contract type)
		C14 (for P11 using the CT1 contract type)
		C15 (for P12 using the CT1 contract type)
	A6	C16 (for P13 using the CT1 contract type)
		C17 (for P11 using the CT1 contract type)
		C18 (for P12 using the CT1 contract type)
		C19 (for P13 using the CT1 contract type)

The following figure graphically represents the above example:

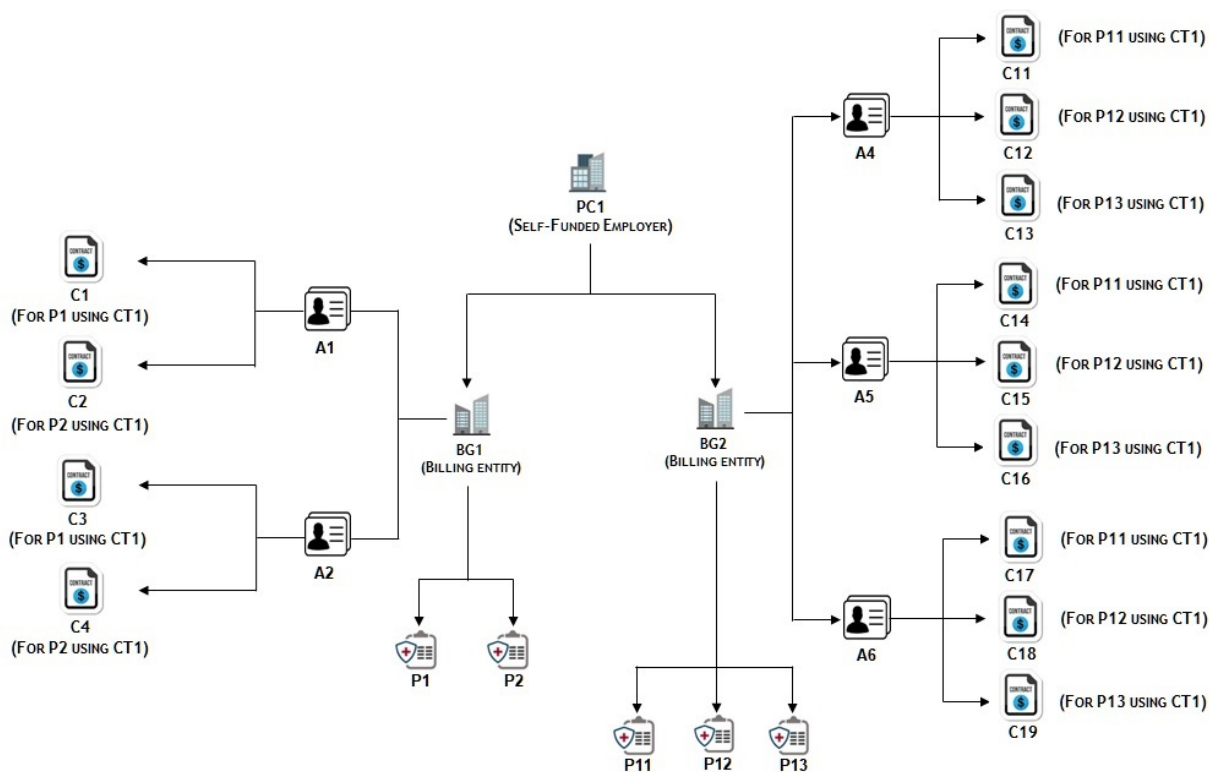

You can also specify comma-separated values for the **Contract Type** parameter. The system will then create a contract using each contract type for each self-funded policy on each account of the bill group. Let us assume that the **Contract Type** parameter in the **C1-ASOBOPOSP** algorithm is set to CT1 , CT2. Now, when you create the self-funded policies named P1 and P2 for BG1 and P11 and P12 for BG2 through a health care inbound message, the system will create the following contracts on the respective accounts:

Bill Group	Account	Contract
BG1	A1	C1 (for P1 using the CT1 contract type)

Bill Group	Account	Contract
		C2 (for P1 using the CT2 contract type)
		C3 (for P2 using the CT1 contract type)
		C4 (for P2 using the CT2 contract type)
	A2	C5 (for P1 using the CT1 contract type)
		C6 (for P1 using the CT2 contract type)
		C7 (for P2 using the CT1 contract type)
		C8 (for P2 using the CT2 contract type)
	BG2	A11
C12 (for P11 using the CT2 contract type)		
C13 (for P12 using the CT1 contract type)		
C14 (for P12 using the CT2 contract type)		
A12		C15 (for P11 using the CT1 contract type)
		C16 (for P11 using the CT2 contract type)
		C18 (for P12 using the CT1 contract type)
		C19 (for P12 using the CT2 contract type)

The following figure graphically represents the above example:

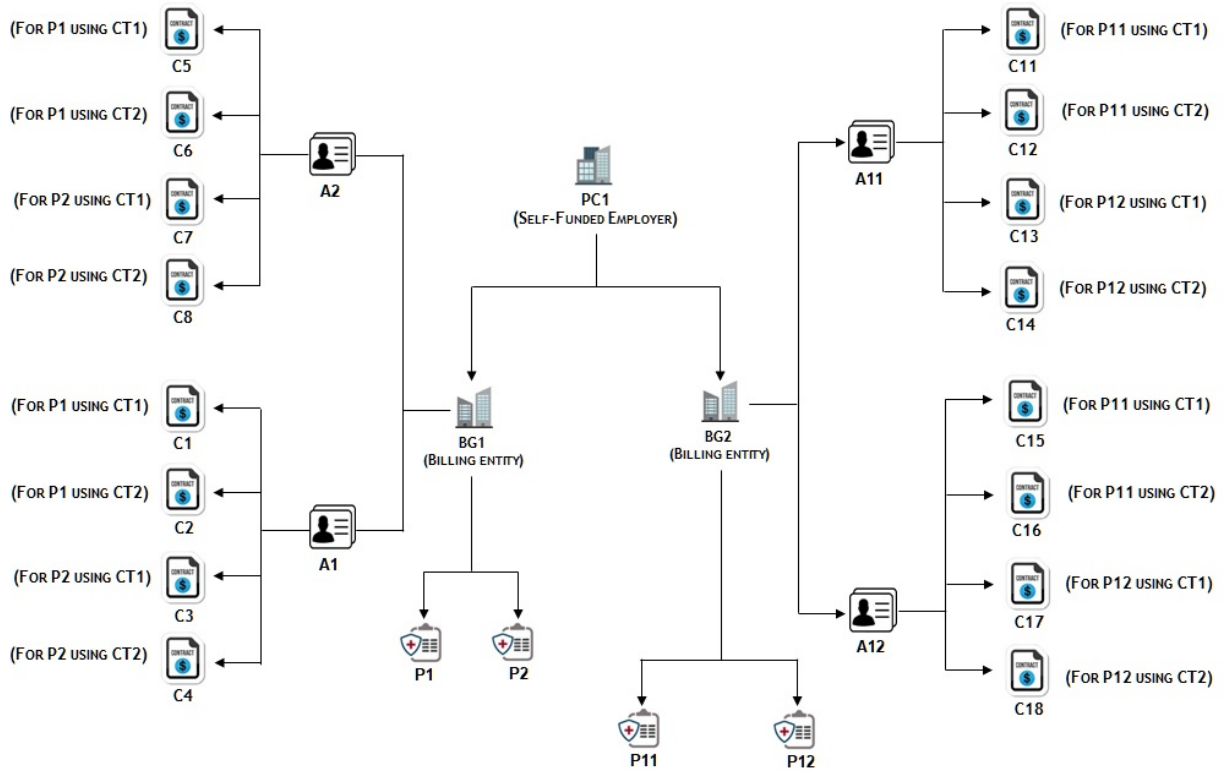

## Fully-Insured Policy Status Transition

The following figure graphically indicates how a fully-insured policy moves from one status to another in its lifecycle:

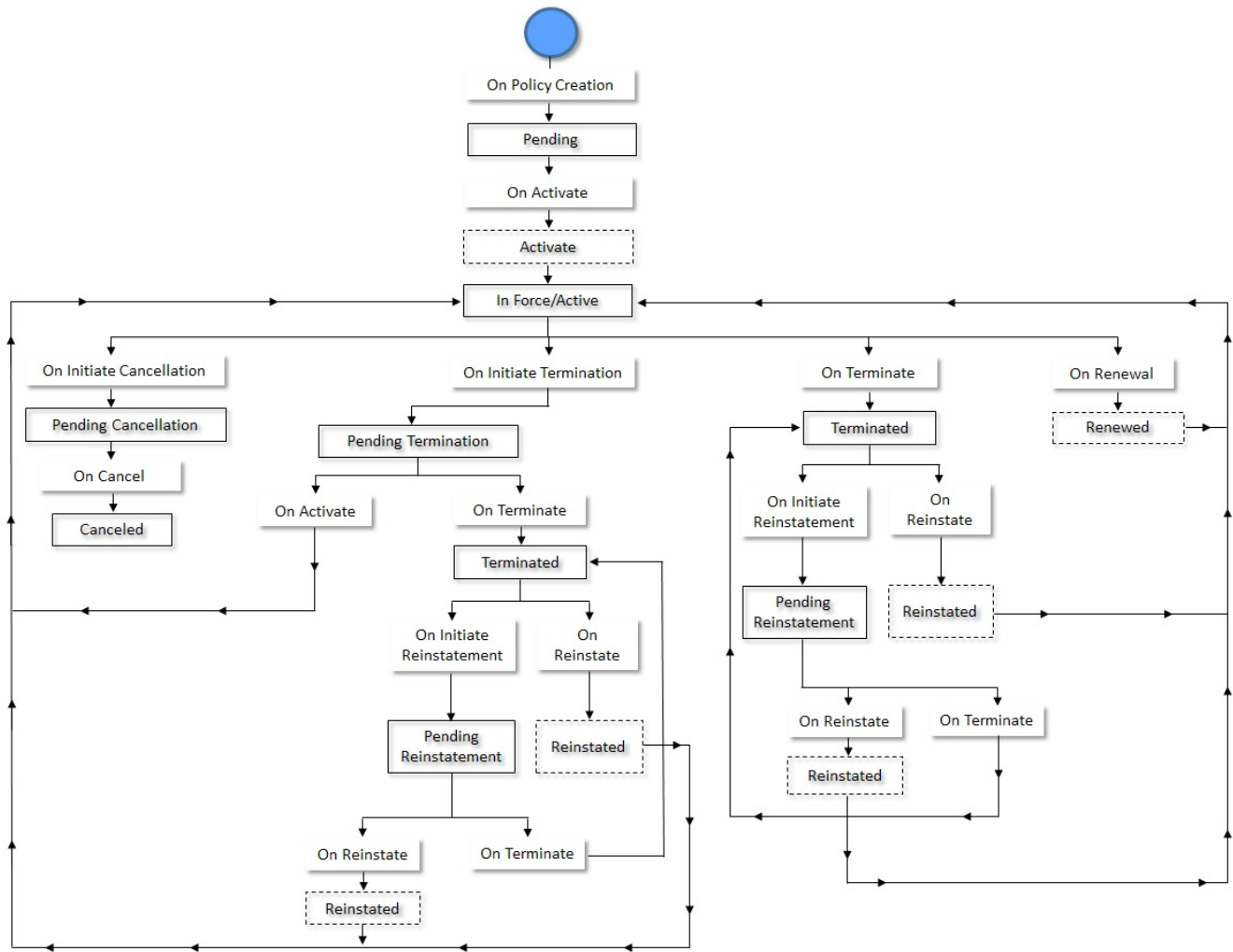

## Self-Funded Policy Status Transition

The following figure graphically indicates how a self-funded policy moves from one status to another in its lifecycle:

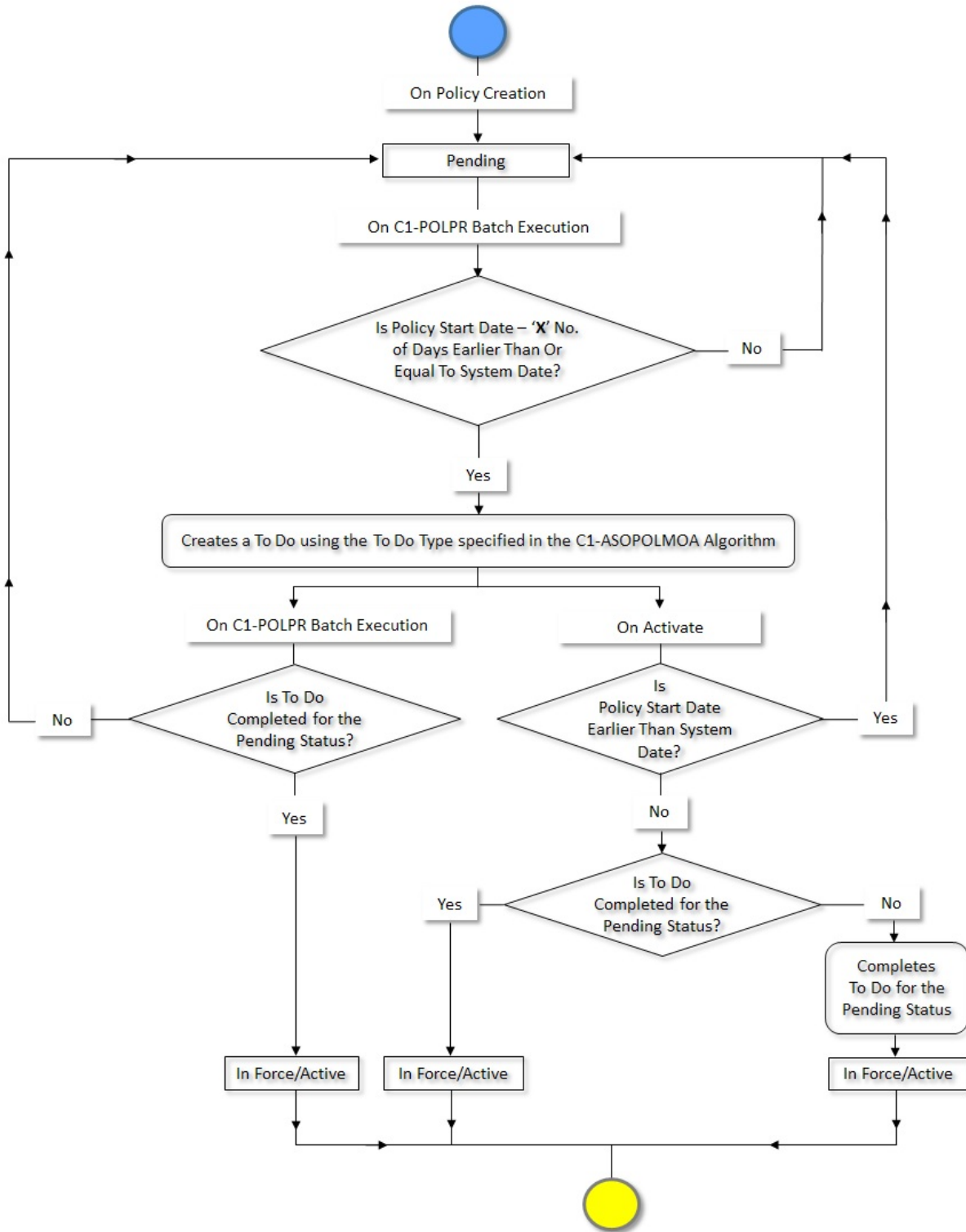

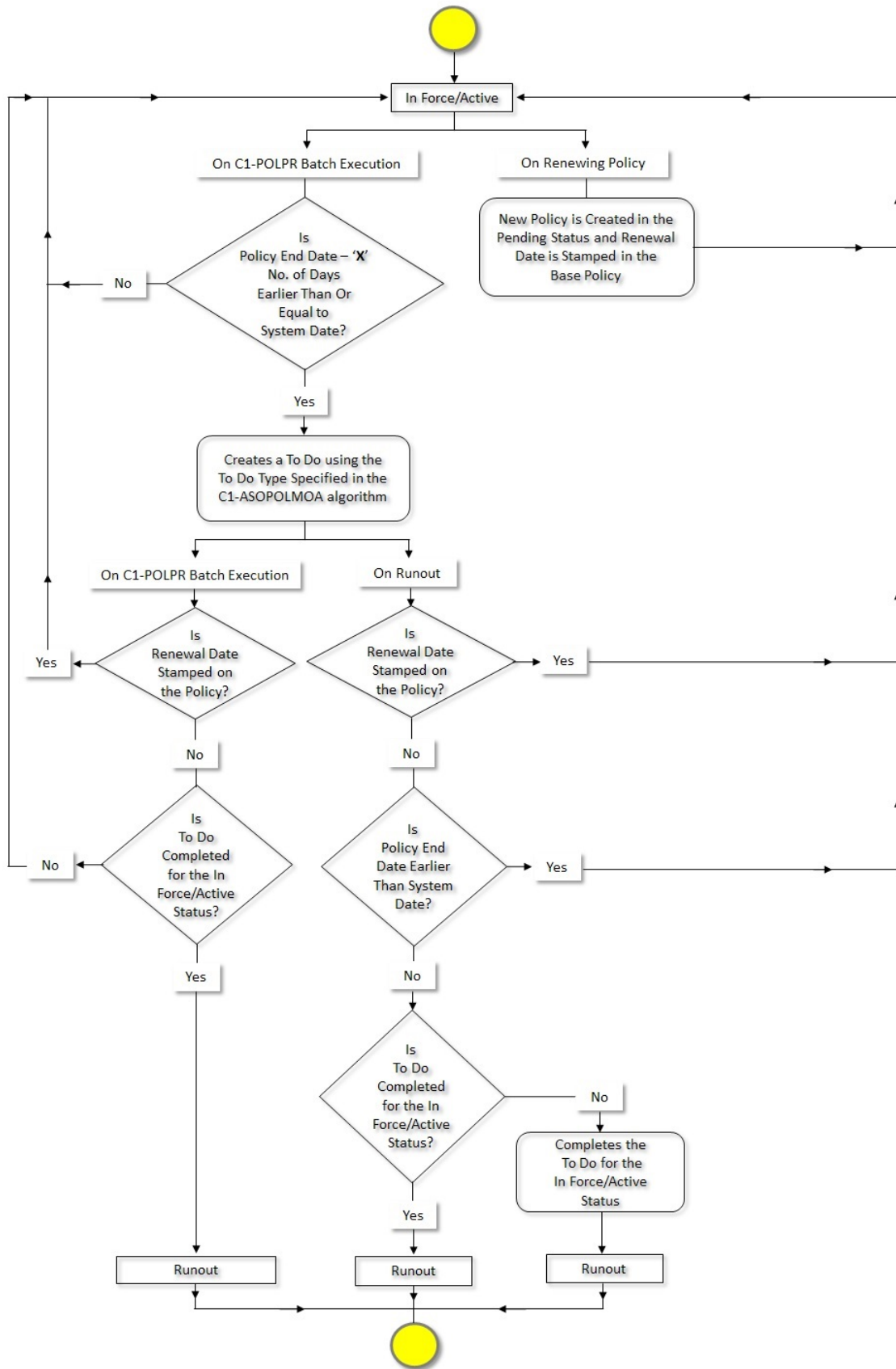

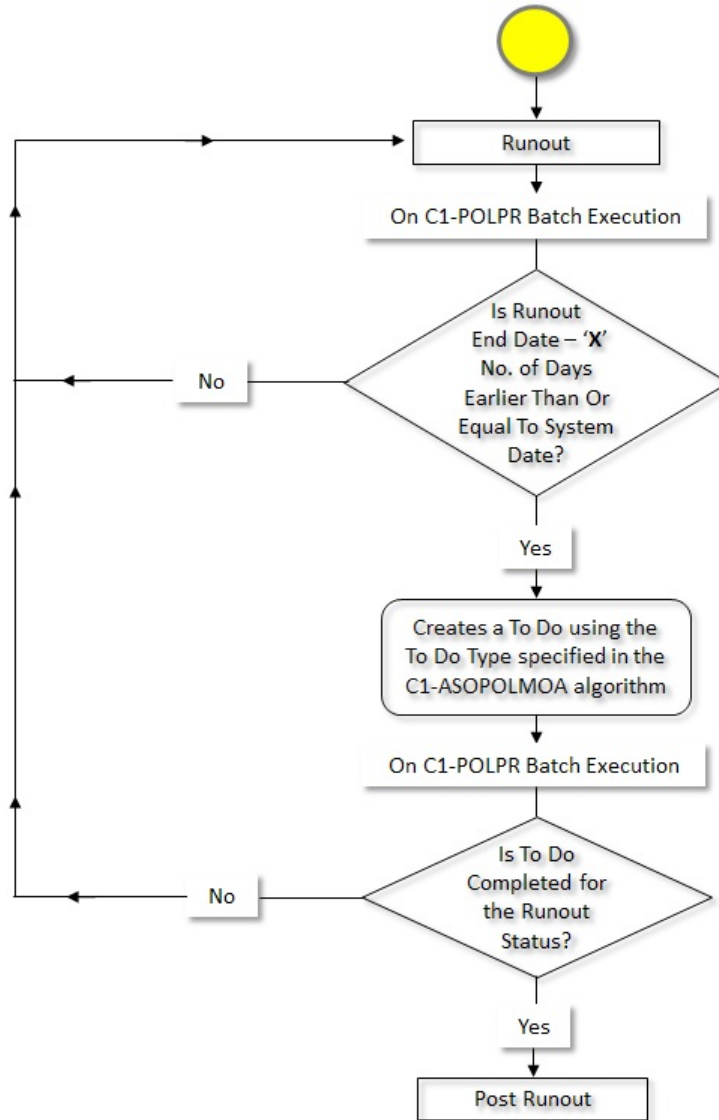

## Membership Status Transition

The following figure graphically indicates how a membership moves from one status to another in its lifecycle:



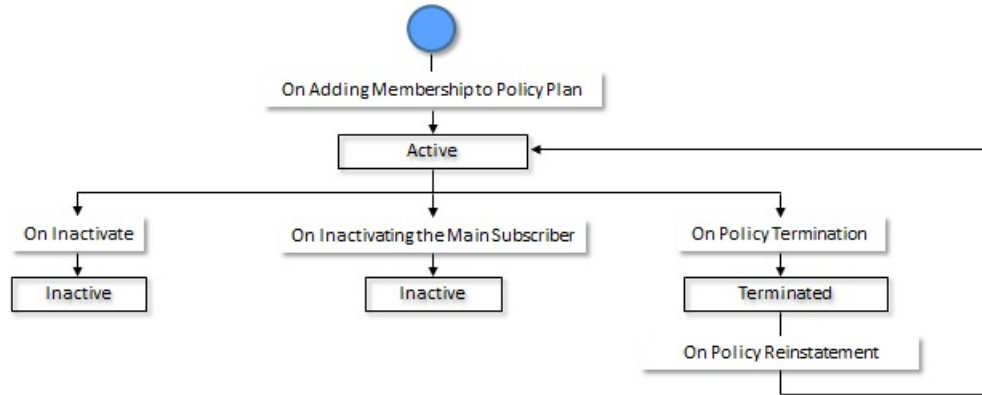

## Algorithms Used in C1-POLICY

The following table lists the algorithms which are attached to the **C1-POLICY** business object:

System Event	Algorithm	Algorithm Type	Description
Audit	C1- READEVNT	C1-READEVNT	Refer to <a href="#">C1-READEVNT</a> on page 2050.
Validation	C1- POLBOVAL	C1-POLBOVAL	Refer to <a href="#">C1-POLBOVAL</a> on page 2051.

The following table lists the algorithms which are used in the lifecycle of the **C1-POLICY** business object:

Status	System Event	Algorithm	Algorithm Type	Description
Pending	Monitor	C1- TRNDFLSYS	C1- TRNDFLSYS	Refer to <a href="#">C1-TRNDFLSYS</a> on page 2051.
Activate	Monitor	F1-AT- RQJ	F1-GEN- BOMNJ	Refer to <a href="#">F1-AT-RQJ</a> on page 1257.
In Force/ Active	Enter	C1- EVCSTSTAT	C1- EVCSTSTAT	Refer to <a href="#">C1-EVCSTSTAT</a> on page 2052.
Pending Termination	Enter	C1- PLCYTRMRQ	C1- PLCYTRMRQ	Refer to <a href="#">C1-PLCYTRMRQ</a> on page 2052.
Terminated	Enter	C1- POLCYTERM	C1- POLCYTERM	Refer to <a href="#">C1-POLCYTERM</a> on page 2052.
	Enter	C1- DELTRMLTR	C1- CRTCUSCNT	Refer to <a href="#">C1-DELTRMLTR</a> on page 2053.
	Enter	C1- EVCSTSTAT	C1- EVCSTSTAT	Refer to <a href="#">C1-EVCSTSTAT</a> on page 2052.

Status	System Event	Algorithm	Algorithm Type	Description
Pending Reinstatement	Enter	C1-PLCYREIRQ	C1-PLCYREIRQ	Refer to <a href="#">C1-PLCYREIRQ</a> on page 2054.
Reinstated	Monitor	F1-AT-RQJ	F1-GEN-BOMNJ	Refer to <a href="#">F1-AT-RQJ</a> on page 1257.
	Enter	C1-POLCYREIN	C1-POLCYREIN	Refer to <a href="#">C1-POLCYREIN</a> on page 2054.
	Enter	C1-CCPOLRE1	C1-CRTCUSCNT	Refer to <a href="#">C1-CCPOLRE1</a> on page 2054.
Renewed	Monitor	F1-AT-RQJ	F1-GEN-BOMNJ	Refer to <a href="#">F1-AT-RQJ</a> on page 1257.
Pending Cancellation	-	-	-	-
Canceled	-	-	-	-

## C1-READEVNT

If this algorithm is attached to the **Audit** system event of a business object, it is invoked whenever you define, edit, or delete the respective entity. It checks whether an active audit event type exists for the entity business object. If so, it considers the active audit event type and creates the audit event using the respective audit event type. The system creates the audit event while:

- Defining an entity when the **Add Action** option is selected in the audit event type.
- Editing an entity when the **Update All** option is selected in the audit event type or when the updated element is listed in the **Audit Elements for Entity Update** section.
- Deleting an entity when the **Delete Action** option is selected in the audit event type.

The entity type and entity ID for which an audit event is created are added corresponding to the audit event in the **C1\_AUDIT\_EVENT** table. In addition, the effective date is stamped corresponding to the audit event in the **C1\_AUDIT\_EVENT** table. Note that if the entity has a start date, then the effective date is set to the entity's start date. But, if the entity does not have a start date, then the effective date is set to the system date.

**Note:** Before creating an audit event, the system checks whether an audit event for the entity ID with the same effective date already exists in the **Pending** or **Error** status for the respective action. If so, the system does not create a new audit event for the entity. Instead, the system adds a new log entry in the existing audit event

At present, this algorithm is designed to work with the business objects of the following maintenance objects:

- C1-POLICY
- C1-ASOPolicy
- C1-Membership
- C1-PolicyPlan
- C1\_PERSON\_BO
- C1-PricingRuleTierBased
- C1-PricingRuleAgeBased

In case, you want to create audit event for any other maintenance objects, you need to create a custom algorithm type.

It contains the following parameters:

- **Audit Event Business Object** – Used to specify the business object using which you want to create the audit event.
- **Audit Event Pending Status** – Used to specify the status in which you want to create the audit event. This parameter is also used for determining whether an audit event for the entity ID already exists in the system.
- **Audit Event Error Status** – Used to specify the status in which an audit event is transitioned when an error occurs while processing the audit event. This parameter is used for determining whether an audit event for the entity ID already exists in the system.

All the above parameters are mandatory.

## C1-POLBOVAL

This algorithm validates a fully-insured policy throughout its lifecycle. It checks the following:

- Whether the policy end date is not earlier than the policy start date.
- Whether the policy person end date is not earlier than the policy person start date.
- Whether the policy person start date is not earlier than the policy start date or later than policy end date.
- Whether the policy person end date is not earlier than the policy start date or later than policy end date.

**Note:** The above validation is done only when the policy is transition to the status which is not specified in the **Skip Status for Policy Person End Date Validation** parameter. For example, if you set the **Skip Status for Policy Person End Date Validation** parameter to **TERMINATED**, the system will not perform the above validation when the status of the policy is changed to **Terminated**.

- Whether the person who is the main customer is associated with the policy.
- Whether the policy person role is specified while associating a person with the policy.

It contains the following parameter:

- **Skip Status for Policy Person End Date Validation** – Used to specify the policy status in which you do not want to validate the policy person end date. You can specify comma-separated values for this parameter.

## C1-TRNDFLSYS

This algorithm checks whether the fully-insured policy is created from the user interface or through an inbound message. If a fully-insured policy is created through an inbound message, the system will automatically transition the fully-insured policy to the default next status specified in its lifecycle.

## F1-AT-RQJ

This algorithm transitions the current status of the business object to the specified status. It contains the following parameters:

- **Next Status** – Used when you want to override the default next status specified in the lifecycle.
- **Next Transition Condition** – Used when you want to override the default next transition condition specified in the lifecycle.

**Note:** At a time, you can specify value for either the **Next Status** or **Next Transition Condition** parameter. If you don't specify any value for these parameters, the system will transition the business object to the default next status specified in its lifecycle.

## C1-EVCSTSTAT

This algorithm updates the **Customer Status** characteristic of the main customer of the policy. This characteristic indicates whether the customer is active or inactive. If the customer owns at least one active policy, the customer status is set to **Active**. However, if the customer does not own any active policy, the customer status is set to **Inactive**.

It is invoked while activating or terminating a fully-insured policy. It contains the following parameters:

- **Customer Status Characteristic Type** – Used to specify the characteristic type whose value should be updated whenever the policy is activated or terminated. You must specify a characteristic type where the characteristic entity is set to **Person**.
- **Active Customer Status Characteristic Value** – Used to specify the characteristic value which should be used when the main customer owns at least one active policy.
- **Inactive Customer Status Characteristic Value** – Used to specify the characteristic value which should be used when the main customer does not own any active policy (in other words, when all policies of the main customer are terminated).
- **Policy Active Status** – Used to specify the status in which at least one policy should exist to indicate that the main customer is active.

All the above parameters are mandatory.

## C1-PLCYTRMRQ

This algorithm creates an outbound message using the outbound message type whenever you initiate the policy termination process from the user interface. While creating the outbound message, the system identifies the account using the characteristic type specified in the **Main Customer Characteristic Type** parameter. The system checks whether this characteristic type is set to the main customer's ID on any account. If so, the system considers the account and then fetches the value of the account identifier type specified in the **Account Identifier Type** parameter.

In addition, it stores the details of the outbound message (which is created) in the log of the policy. It contains the following parameters:

- **Outbound Message Type** – Used to specify the outbound message type using which you want to create the outbound message. You must specify an outbound message type which is already defined in the system.
- **Source System** – Used to specify the source system that you want to use in the outbound message. You must specify a source system which is already defined in the **C1-SourceSystemLookup** extendable lookup.
- **Account Identifier Type** – Used to specify the account identifier type whose value you want to use in the outbound message. You must specify an account identifier type which is already defined in the system.
- **Main Customer Characteristic Type** – Used to specify the characteristic type using which you want to identify the account of the main customer. You must specify a characteristic type where the characteristic entity is set to **Person**.

All the above parameters are mandatory.

## C1-POLCYTERM

This algorithm sets the end date of the following entities to the termination date when the respective condition is met:

- Policy (when the termination date is not earlier than the policy start date or later than the policy end date)
- Policy Person (when the termination date falls within the date range in which the person is associated with the policy)
- Policy Plan (when the termination date falls within the date range of the policy plan)
- Membership (when the termination date falls within the date range of the membership)

- Member Person (when the termination date falls within the date range in which the person is added to the membership)
- Contracts Associated with the Membership (when the termination date falls within the date range of the contract)

It contains the following parameters:

- **Membership Old Status** – Used to specify the status from which you want to transition the membership when the policy is terminated.
- **Membership New Status** – Used to specify the status to which you want to transition the membership when the policy is terminated.

## C1-DELTRMLTR

This algorithm creates a customer contact whenever the policy is transition to the status where it is attached. For example, if this algorithm is attached to the **TERMINATED** status, it creates a customer contact whenever the policy is terminated. You can create a customer contact while terminating a policy. Optionally, you can configure the algorithm such that a customer contact is created when a particular status reason is specified while terminating a policy.

Once a customer contact is created, the policy for which the customer contact is created is stored as a characteristic on the customer contact. In addition, the customer contact which is created for the policy is stored as a characteristic in the log of the policy.

It contains the following parameters:

- **Check Policy Status Reason** – Used when you want to create a customer contact when the policy is terminated for a particular reason. The valid values are:
  - **Y** – Used to indicate that the system should create a customer contact when a particular status reason is specified while terminating a policy.
  - **N** – Used to indicate that the system should create a customer contact while terminating a policy irrespective of the status reason.
- **Policy Status Reason Codes** – Used to specify the status reason defined for the **TERMINATED** status. You can specify comma-separated values for this parameter.
- **Customer Contact Class** – Used to specify the customer contact class using which you want to create the customer contact. This field is mandatory.
- **Customer Contact Type** – Used to specify the customer contact type using which you want to create the customer contact. This field is mandatory.
- **Consolidate Customer Contact** – Used to indicate whether the system should update the existing customer contact or create a new customer contact for the main customer of the policy. The valid values are:
  - **Y** – If this parameter is set to **Y**, the system checks whether a customer contact is already created for the main customer of the policy on the system date. If so, the system does not create a new customer contact. Instead, it updates the existing customer contact of the main customer of the policy. However, if the customer contact is not already created on the system date, the system creates a new customer contact for the main customer of the policy.
  - **N** – If this parameter is set to **N**, the system creates a new customer contact for the main customer of the policy and does not update the existing customer contact, if any.

**Note:** If you do not specify the value for this parameter, by default, it is set to **N**.

- **Policy ID Characteristic Type** – Used to specify the characteristic type which you want to define for the customer contact. This characteristic indicates the policy for which the customer contact is created. You must specify a characteristic type where the characteristic entity is set to **Customer Contact**. This field is mandatory.
- **Customer Contact Characteristic Type** – Used to specify the characteristic type which you want to use in the log of the policy. This characteristic indicates the customer contact which is created for the policy. You must specify a characteristic type where the characteristic entity is set to **Policy**. This field is mandatory.

- **Status To Skip Process** – Used when you do not want to create the customer contact when the policy is transition to a particular status. You can specify comma-separated values for this parameter.

## C1-PLCYREIRQ

This algorithm creates an outbound message using the outbound message type whenever you initiate the policy reinstatement process from the user interface. In addition, it stores the details of the outbound message (which is created) in the log of the policy.

It contains the following parameters:

- **Outbound Message Type** – Used to specify the outbound message type using which you want to create the outbound message. You must specify an outbound message type which is already defined in the system.
- **Source System** – Used to specify the source system that you want to use in the outbound message. You must specify a source system which is already defined in the **C1-SourceSystemLookup** extendable lookup.

All the above parameters are mandatory.

## C1-POLCYREIN

This algorithm updates the end date of the following entities to the respective original end date:

- Policy
- Policy Person
- Policy Plan
- Membership
- Member Person
- Contracts Associated with the Membership

**Note:** The system stores the original end date of the above listed entities when you define or edit a policy, policy plan, or membership.

Here, the assumption is that the pass-through billable charges information for the membership will be sent again through an inbound message along with the reinstatement reason. And, therefore the exiting billable charges will not be extended.

It contains the following parameters:

- **Membership Old Status** – Used to specify the status from which you want to transition the membership when the policy is reinstated.
- **Membership New Status** - Used to specify the status to which you want to transition the membership when the policy is reinstated. This field is mandatory.

## C1-CCPOLRE1

This algorithm creates a customer contact whenever the policy is transition to the status where it is attached. For example, if this algorithm is attached to the **REINSTATE** status, it creates a customer contact whenever the policy is reinstated. You can create a customer contact while reinstating a policy. Optionally, you can configure the algorithm such that a customer contact is created when a particular status reason is specified while reinstating a policy.

Once a customer contact is created, the policy for which the customer contact is created is stored as a characteristic on the customer contact. In addition, the customer contact which is created for the policy is stored as a characteristic in the log of the policy.

It contains the following parameters:

- **Check Policy Status Reason** – Used when you want to create a customer contact when the policy is reinstated for a particular reason. The valid values are:

- **Y** – Used to indicate that the system should create a customer contact when a particular status reason is specified while reinstating a policy.
- **N** – Used to indicate that the system should create a customer contact while reinstating a policy irrespective of the status reason.
- **Policy Status Reason Codes** – Used to specify the status reason defined for the **REINSTATE** status. You can specify comma-separated values for this parameter.
- **Customer Contact Class** – Used to specify the customer contact class using which you want to create the customer contact. This field is mandatory.
- **Customer Contact Type** – Used to specify the customer contact type using which you want to create the customer contact. This field is mandatory.
- **Consolidate Customer Contact** – Used to indicate whether the system should update the existing customer contact or create a new customer contact for the main customer of the policy. The valid values are:
  - **Y** – If this parameter is set to **Y**, the system checks whether a customer contact is already created for the main customer of the policy on the system date. If so, the system does not create a new customer contact. Instead, it updates the existing customer contact of the main customer of the policy. However, if the customer contact is not already created on the system date, the system creates a new customer contact for the main customer of the policy.
  - **N** – If this parameter is set to **N**, the system creates a new customer contact for the main customer of the policy and does not update the existing customer contact, if any.

**Note:** If you do not specify the value for this parameter, by default, it is set to **N**.

- **Policy ID Characteristic Type** – Used to specify the characteristic type which you want to define for the customer contact. This characteristic indicates the policy for which the customer contact is created. You must specify a characteristic type where the characteristic entity is set to **Customer Contact**. This field is mandatory.
- **Customer Contact Characteristic Type** – Used to specify the characteristic type which you want to use in the log of the policy. This characteristic indicates the customer contact which is created for the policy. You must specify a characteristic type where the characteristic entity is set to **Policy**. This field is mandatory.
- **Status To Skip Process** – Used when you do not want to create the customer contact when the policy is transition to a particular status. You can specify comma-separated values for this parameter.

## Algorithms Used in C1-PolicyPlan

The following table lists the algorithms which are attached to the **C1-PolicyPlan** business object:

System Event	Algorithm	Algorithm Type	Description
Audit	C1-PPCONCRE	C1-PPCONCRE	Refer to <a href="#">C1-PPCONCRE</a> on page 2055.
Validation	C1-VALPPBO	C1-VALPPBO	Refer to <a href="#">C1-VALPPBO</a> on page 2056.

### C1-PPCONCRE

This algorithm is invoked when you create or edit a policy plan from the user interface or through an inbound message. It creates a contract in either of the following ways:

- If a price item is associated with the policy plan, it creates a contract using the contract type which is associated with the price item.
- If a pricing rule type is associated with the policy plan and the pricing rule type contains one or more price items, it creates a contract using a distinct contract type which is associated with each price item.

Let us assume that PRT1 is associated with the policy plan and it contains three price items – P1, P2, and P3. Now, if the P1 is associated with the CT1 contract type, P2 is associated with the CT2 contract type, and P3 is associated with the CT3 contract type, the system will create three contracts - C1 using CT1, C2 using CT2, and C3 using CT3. However, if the P1 and P3 are associated with the CT1 contract type and P2 is associated with the CT2 contract type, the system will create two distinct contracts - C1 using CT1 and C2 using CT2.

If multiple pricing rule types are associated with the policy plan and each pricing rule type contains multiple price items, it creates a contract using a distinct contract type which is associated with each price item on each pricing rule type.

If the policy plan belongs to an individual policy of the parent customer (i.e. a policy where a bill group is not associated), the system will create contracts of distinct contract types for each account of the parent customer and bill groups. However, if the policy plan belongs to a policy of a bill group (where the parent customer is the policy holder), the system will create contracts of distinct contract types for each account of the parent customer and the bill group.

The status of each contract is set to **Active**. The contract start date is set to the start date of the respective plan. If the same contract type is associated with the same or different price items on the same or different pricing rule types of different plans, the contract start date is set to the start date of the earliest plan. The default rate schedule specified on the respective contract type is added to the contract in the rate information and its effective date is set to the contract start date.

**Note:**

The system creates a contract using a contract type for an account only when the division to which the account and contract type belongs is same.

If a contract of a contract type is already present on the account, the system will not create a new contract. Instead, it will update the start date of the existing contract, if required.

If the same contract type is associated with the same or different price items on the same or different pricing rule types of different plans on different policies, the contract start date is set to the start date of the earliest plan across policies.

## C1-VALPPBO

This algorithm validates a policy plan. It checks the following:

- Whether the policy plan end date is not earlier than the policy plan start date.
- Whether the policy plan start date is not earlier than the policy start date or later than policy end date.
- Whether the policy plan end date is not earlier than the policy start date or later than policy end date.
- Whether the price item or at least one pricing rule type is associated with the policy plan.

## Algorithms Used in C1-Membership

The following table lists the algorithms which are attached to the **C1-Membership** business object:

System Event	Algorithm	Algorithm Type	Description
Audit	C1-FIAUDEV	C1-FIAUDEV	Refer to <a href="#">C1-FIAUDEV</a> on page 2057.
Pre-Processing	C1-MEMSTPRE	C1-MEMSTPRE	Refer to <a href="#">C1-MEMSTPRE</a> on page 2058.
Validation	C1-VALMEMBO	C1-VALMEMBO	Refer to <a href="#">C1-VALMEMBO</a> on page 2058.

The following table lists the algorithms which are used in the lifecycle of the **C1-Membership** business object:

Status	System Event	Algorithm	Algorithm Type	Description
Active	-	-	-	-



Status	System Event	Algorithm	Algorithm Type	Description
Inactive	Enter	C1-MEMINACT	C1-MEMINACT	Refer to <a href="#">C1-MEMINACT</a> on page 2058.
Terminated	-	-	-	-

## C1-FIAUDEV

If this algorithm is attached to the **Audit** system event of the **C1-Membership** and **C1\_PERSON\_BO** business objects, it is invoked whenever you define, edit, or delete the respective entity. It checks whether an active audit event type exists for the entity business object. If so, it considers the active audit event type and creates the audit event using the respective audit event type. The system creates the audit event whenever a membership is added to a policy plan and member person is added to a membership. It also creates the audit event whenever the membership and member person details are updated. However, note that the audit events are created in the update scenario only when the element listed for auditing in the age based or tier based pricing rule types is updated. The system considers only those pricing rule types whose pricing rules are effective during the respective entity (i.e. membership or member person whichever is updated) date range.

It creates one or more audit events in the **Pending** status. The entity type and entity ID for which an audit event is created are added corresponding to the audit event in the **C1\_AUDIT\_EVENT** table. In addition, the effective date is stamped corresponding to the audit event in the **C1\_AUDIT\_EVENT** table.

### Note:

The system creates an audit event whenever the membership start and end dates and member person's start and end dates are changed in the system irrespective of whether these fields are listed for auditing or not in the age based or tier based pricing rule types.

Before creating an audit event, the system checks whether an audit event for the entity ID with the same effective date already exists in the **Pending** or **Error** status for the respective action. If so, the system does not create a new audit event for the entity. Instead, the system adds a new log entry in the existing audit event.

For each audit event, this algorithm derives the memberships on the policy plans which are impacted and the pricing rule types whose pricing rules are defined on the respective policy plans. A repricing entity detail record is then created for each membership, pricing rule type, and effective date combination in the **CI\_REPRC\_ENTITY\_DTL** table. The status of the repricing entity detail record is set to **P**. Once the repricing entity detail records are created successfully, the status of the audit event is changed to **Complete**.

It contains the following parameters:

- **Audit Event Business Object** – Used to specify the business object using which you want to create the audit event.
- **Audit Event Pending Status** – Used to specify the status in which you want to create the audit event. This parameter is also used for determining whether an audit event for the entity ID already exists in the system.
- **Audit Event Error Status** – Used to specify the status in which an audit event is transitioned when an error occurs while processing the audit event. This parameter is used for determining whether an audit event for the entity ID already exists in the system.

All the above parameters are mandatory.

### Related Topics

For more information on...	See...
How the audit events are created and processed for an age based or tier based pricing rule	<a href="#">Age Based and Tier Based Pricing Rules Audit Process</a> on page 2835
How the audit events are created and processed for a membership	<a href="#">Membership Audit Process</a> on page 2836

For more information on...	See...
How the audit events are created and processed for a person	<a href="#">Person Audit Process</a> on page 2839

## C1-MEMSTPRE

Once the status of the main subscriber is changed to **Inactive**, this algorithm changes the status of the membership to the value specified in the **Membership Inactive Status** option type of the **C1-ASOBLLNG** feature configuration. In addition, it does not allow you to add a member person in the **Inactive** status to a membership.

## C1-VALMEMBO

This algorithm validates a membership. It checks the following:

- Whether the membership end date is not earlier than the membership start date.
- Whether the membership start date is not earlier than the policy plan start date or later than policy plan end date.
- Whether the membership end date is not earlier than the policy plan start date or later than policy plan end date.
- Whether the policy plan for which you want to define the membership is specified.
- Whether the person who is the main subscriber is added to the membership.
- Whether the relationship type is specified while adding a person to the membership.

## C1-MEMINACT

This algorithm changes the status of the member person to the value specified in the **Membership Person Inactive Status** option type of the **C1-ASOBLLNG** feature configuration. It also does the following:

- Cancels the billable charges which are created for the membership
- Cancels the corresponding bill segments (if any)

If an audit event exists for the membership which is inactivated, the **BO\_STATUS\_CD** column corresponding to the record in the **C1\_AUDIT\_EVENT**, **C1\_AUDIT\_EVENT\_LOG**, and **CI\_PRCE\_CALC** tables is set to **INVALID**. If a repricing entity detail record exists for the membership in the **PENDING** or **ERROR** status, then the **BO\_STATUS\_CD** column corresponding to the record in the **CI\_REPRC\_ENTITY\_DTL** table is set to **COMPLETE**. If a repricing request exists for the membership in the **PENDING** or **ERROR** status, then the **BO\_STATUS\_CD** column corresponding to the record in the **CI\_REPRC\_REQ\_DTL** table is set to **COMPLETE**.

## Algorithms Used in C1-ASOPolicy

The following table lists the algorithms which are attached to the **C1-ASOPolicy** business object:

System Event	Algorithm	Algorithm Type	Description
Validation	C1-ASOPOLVAL	C1-ASOPOLVAL	Refer to <a href="#">C1-ASOPOLVAL</a> on page 2059.
Post-Processing	C1-ASOBOPOSP	C1-ASOPOLPOS	Refer to <a href="#">C1-ASOBOPOSP</a> on page 2060.
	C1-ASOPRUCPY	C1-ASOPRUCPY	Refer to <a href="#">C1-ASOPRUCPY</a> on page 2060.

The following table lists the algorithms which are used in the lifecycle of the **C1-ASOPolicy** business object:

Status	System Event	Algorithm	Algorithm Type	Description
Pending	Monitor	C1-ASOPOLMOA	C1-ASOPOLMOA	Refer to <a href="#">C1-ASOPOLMOA</a> on page 2060.
	Enter	C1-ASOPOLREN	C1-ASOPOLREN	Refer to <a href="#">C1-ASOPOLREN</a> on page 2061.
	Exit	C1-ASOPCKTD	C1-ASOPCKTD	Refer to <a href="#">C1-ASOPCKTD</a> on page 2061.
In Force/ Active	Monitor	C1-ASOPOLMOA	C1-ASOPOLMOA	Refer to <a href="#">C1-ASOPOLMOA</a> on page 2060.
	Exit	C1-ASOPCKTD	C1-ASOPCKTD	Refer to <a href="#">C1-ASOPCKTD</a> on page 2061.
Runout	Monitor	C1-ASOPOLMOA	C1-ASOPOLMOA	Refer to <a href="#">C1-ASOPOLMOA</a> on page 2060.
	Exit	C1-ASOPCKTD	C1-ASOPCKTD	Refer to <a href="#">C1-ASOPCKTD</a> on page 2061.
Post Runout	-	-	-	-

## C1-ASOPOLVAL

This algorithm validates a self-funded policy throughout its lifecycle. It checks the following:

- The policy end date is not earlier than the policy start date.
- The runout end date is later than the policy end date.
- The runout end date is later than the system date while editing the policy which is in the **Runout** status.
- The runout end date is not removed when the policy is in the **Runout** or **Post Runout** status.
- The policy end date is not modified when the policy is in the **Runout** status.
- The policy end date is not set to a date which is later than or equal to the start date of a pricing rule which is defined for the **Runout** status.
- The runout end date is not set to a date which is later than or equal to the start date of a pricing rule which is defined for the **Post Runout** status.
- The runout end date is not set to a date which is earlier than the end date of a pricing rule which is defined for the **Runout** status.
- The policy is not edited when it is in the **Post Runout** status.
- The policy start date is not modified when the policy is in the **In Force/Active**, **Runout**, or **Post Runout** status.
- The policy person end date is not earlier than the policy person start date.
- The policy person role is specified while associating a person with the policy.
- One of the policy persons is set as the main customer of the policy.
- The policy end date is not changed when the policy is renewed.

## C1-ASOBOPOSP

This algorithm is invoked when you create a self-funded policy either from the user interface or through an inbound message. It creates a contract of the specified contract type for the self-funded policy on each account of the bill group. For example, if you create a self-funded policy named P1 for a bill group who has two accounts - A1 and A2, the system will create two contracts for P1 - one on the A1 account and another on the A2 account.

It contains the following parameter:

- **Contract Type** - Used to indicate the contract type whose contract you want to create for the self-funded policy on each account of the bill group. You can also specify comma-separated values for this parameter. It will then create a contract of each contract type for the self-funded policy on each account of the bill group.

## C1-ASOPRUCPY

This algorithm is invoked when the **Copy Pricing Rules** option is selected while renewing a self-funded policy. It copies the following pricing rules of the base policy and creates new pricing rules for the renewed policy:

- Claim
- Retention Type Claim Based
- Retention Type Enrollment Based
- Recurring Flat Fees
- Ancillary

While copying a pricing rule, the start and end dates of the new pricing rule are set to the renewed policy's start and end dates, respectively. If there are multiple pricing rules which are created using the same pricing rule type and are effective for the different date range, the system copies only one pricing rule from the base policy with the latest date range.

## C1-ASOPOLMOA

This algorithm is invoked when the **Policy Periodic Monitor (C1-POLPR)** batch is executed. It does the following:

- If the self-funded policy is in the **Pending** status and the policy start date - X days is earlier than or equal to the system date, it creates a To Do using the To Do type which is specified in the **To Do Type for Pending Status** parameter.
- If the start date of the self-funded policy is earlier than or equal to the system date and the To Do created using the To Do type specified in the **To Do Type for Pending Status** parameter is completed, it changes the status of the self-funded policy from **Pending** to **In Force/Active**.
- If the self-funded policy is in the **In Force/Active** status and the policy end date - X days is earlier than or equal to the system date, it creates a To Do using the To Do type which is specified in the **To Do Type for Active Status** parameter.
- If the end date of the self-funded policy is earlier than or equal to the system date and the To Do created using the To Do type specified in the **To Do Type for Active Status** parameter is completed, it changes the status of the self-funded policy from **In Force/Active** to **Runout**.
- If the self-funded policy is in the **Runout** status and the runout end date - X days is earlier than or equal to the system date, it creates a To Do using the To Do type which is specified in the **To Do Type for Runout Status** parameter.
- If the runout end date of the self-funded policy is earlier than or equal to the system date and the To Do created using the To Do type specified in the **To Do Type for Runout Status** parameter is completed, it changes the status of the self-funded policy from **Runout** to **Post Runout**.

It contains the following parameters:

- **To Do Type for Pending Status** - Used to indicate the To Do type using which you want to create the To Do, X days prior to the policy start date.
- **To Do Type for Active Status** - Used to indicate the To Do type using which you want to create the To Do, X days prior to the policy end date.
- **To Do Type for Runout Status** - Used to indicate the To Do type using which you want to create the To Do, X days prior to the runout end date.
- **X Days** - Used to specify the number of days prior to which you want to create a To Do for the self-funded policy.

All these parameters are mandatory.

## C1-ASOPOLREN

This algorithm is invoked when you renew a self-funded policy. Once the new policy is created in the **Pending** status, it stamps the renewal date on the base policy.

## C1-ASOPCKTD

This algorithm is invoked when you click the **Activate** and **Runout** buttons in the **Policy** screen. On clicking the **Activate** button, it checks whether the To Do created for the **Pending** status is completed. If the To Do created for the **Pending** status is not completed, it completes the To Do and then changes the status of the self-funded policy from **Pending** to **In Force/Active**.

Similarly, on clicking the **Runout** button, it checks whether the To Do created for the **In Force/Active** status is completed. If the To Do created for the **In Force/Active** status is not completed, it completes the To Do and then changes the status of the self-funded policy from **In Force/Active** to **Runout**.

It also validates the following:

- The status of the policy is not changed from **Pending** to **In Force/Active** until the system date is later than or equal to the policy start date.
- The status of the policy is not changed from **In Force/Active** to **Runout** when the runout end date is not specified.
- The status of the policy is not changed from **In Force/Active** to **Runout** until the system date is later than the policy end date.
- The status of the policy is not changed to **Runout** if it is renewed.

In addition, it also changes the status of the base policies to **Runout** when the status of the latest renewed policy is changed to **Runout**.

## Policy Type

---

Oracle Revenue Management and Billing enables you to define a policy type using which you can create a policy. The policy type helps the system to determine:

- **Policy Category** - The category implies the line of business in the health care domain for which the policy should be created using the policy type. The valid values are:
  - Fully-Insured Group
  - Fully-Insured Individual
  - Self-Funded

**Note:** At present, the **Fully-Insured Individual** policy category is not supported in the system.



- **Policy Business Object** - The business object using which the policy should be created in the system. You can specify the **C1-POLICY** or **C1-ASOPolicy** business object depending on whether you want to create the policy type for the fully-insured or self-funded health care business.

The **Policy Type** screen allows you to define, edit, copy, and delete a policy type. It contains the following zones:

- [Policy Type List](#) on page 2062
- [Policy Type](#) on page 2062

## Policy Type List

The **Policy Type List** zone lists the policy types that are already defined in the system. It contains the following columns:

Column Name	Column Description
Policy Type	Displays the policy type.
Description	Displays the description of the policy type.
Policy Category	Indicates the category to which the policy type belongs. The valid values are: <ul style="list-style-type: none"> <li>• Self-Funded</li> <li>• Fully-Insured Group</li> <li>• Fully-Insured Individual</li> </ul>
Edit	On clicking the <b>Edit</b> (  ) icon, the <b>Policy Type</b> screen appears where you can edit the details of the policy type.
Duplicate	On clicking the <b>Duplicate</b> (  ) icon, the <b>Policy Type</b> screen appears where you can define a new policy type using an existing policy type.
Delete	On clicking the <b>Delete</b> (  ) icon, you can delete the policy type. <div style="border: 1px solid black; padding: 5px; margin-top: 5px;"> <b>Note:</b> You can delete a policy type only when a policy is not created using the policy type. </div>

**Note:** Pagination is used to display limited number of records in this zone. You can use the navigation links, such as **Previous** and **Next** to navigate between pages.

On clicking the **Broadcast** () icon corresponding to a policy type, the **Policy Type** zone appears with the details of the respective policy type.

You can filter the list using the **Policy Category** field available in the **Filter** area. By default, the **Filter** area is hidden.

You can view the **Filter** area by clicking the **Filters** () icon in the upper right corner of this zone.

### Related Topics

For more information on...	See...
How to edit a policy type	<a href="#">Editing a Policy Type</a> on page 2066
How to copy a policy type	<a href="#">Copying a Policy Type</a> on page 2068
How to delete a policy type	<a href="#">Deleting a Policy Type</a> on page 2069
How to view the details of a policy type	<a href="#">Viewing the Policy Type Details</a> on page 2070

## Policy Type

The **Policy Type** zone displays the details of the policy type. It contains the following sections:

- **Main** - Displays basic information about the policy type. It contains the following fields:

Field Name	Field Description
Policy Type	Displays the policy type.
Policy Business Object	Indicates the business object using which the policy should be created. In addition, a context menu appears corresponding to this field which helps in navigating to other screens in the application.  <b>Note:</b> It has a link. On clicking the link, the <b>Business Object</b> screen appears where you can view the details of the respective business object.
Description	Displays the description of the policy type.
Status	Indicates the status of the policy type. The valid values are: <ul style="list-style-type: none"> <li>Active</li> <li>Inactive</li> </ul>
Policy Category	Indicates the category to which the policy type belongs. The valid values are: <ul style="list-style-type: none"> <li>Self-Funded</li> <li>Fully-Insured Group</li> <li>Fully-Insured Individual</li> </ul>
Detailed Description	Displays additional information about the policy type.

- **Characteristics** - Lists the characteristics defined for the policy type. It contains the following columns:

Column Name	Column Description
Characteristic Type	Indicates the characteristic type.
Characteristic Value	Displays the value of the characteristic type.

- **Record Actions** - This section contains the following buttons:

Button Name	Button Description
Edit	Used to edit the details of the policy type.
Delete	Used to delete the policy type.  <b>Note:</b> You can delete a policy type only when a policy is not created using the policy type.
Duplicate	Used to create a new policy type using an existing policy type.

- **Record Information** - This section contains the following field:

Field Name	Field Description
Business Object	Indicates the business object using which the policy type is created. In addition, a context menu appears corresponding to this field which helps in navigating to other screens in the application.  <b>Note:</b> It has a link. On clicking the link, the <b>Business Object</b> screen appears where you can view the details of the respective business object.

By default, the **Policy Type** zone does not appear in the **Policy Type** screen. It appears only when you click the **Broadcast**  icon corresponding to the policy type in the **Policy Type List** zone.

### **Related Topics**

<b>For more information on...</b>	<b>See...</b>
How to edit a policy type	<a href="#">Editing a Policy Type</a> on page 2066
How to delete a policy type	<a href="#">Deleting a Policy Type</a> on page 2069
How to copy a policy type	<a href="#">Copying a Policy Type</a> on page 2068
How to view the details of a policy type	<a href="#">Viewing the Policy Type Details</a> on page 2070

## **Defining a Policy Type**

### **Prerequisites**

To define a policy type, you should have:

- Required policy business object defined in the application

**Note:** The **C1-POLICY** and **C1-ASOPolicy** business objects are shipped with the product. You can use the **C1-POLICY** business object to create a fully-insured policy and the **C1-ASOPolicy** business object to create a self-funded policy.

### **Procedure**

To define a policy type:

1. Click the **Admin** link in the **Application** toolbar.  
A list appears.
2. From the **Admin** menu, select **P** and then click **Policy Type**.  
A sub-menu appears.
3. Click the **Add** option from the **Policy Type** sub-menu.

The **Policy Type** screen appears. It contains the following sections:

- **Main** - Used to specify basic details about the policy type.
- **Characteristics** - Used to define characteristics for the policy type.

The **Main** section contains the following fields:

<b>Field Name</b>	<b>Field Description</b>	<b>Mandatory (Yes or No)</b>
Policy Type	Used to specify the policy type.	Yes
Business Object	Indicates the business object using which you are defining the policy type.	Not applicable
Policy Business Object	Used to indicate the business object using which you want to create a policy.	Yes
Description	Used to specify the description for the policy type.	Yes



Field Name	Field Description	Mandatory (Yes or No)
Status	Used to indicate the status of the policy type. The valid values are: <ul style="list-style-type: none"> <li>Active</li> <li>Inactive</li> </ul>	Yes
Policy Category	Used to indicate the category to which the policy type belongs. The valid values are: <ul style="list-style-type: none"> <li>Fully-Insured Group</li> <li>Fully-Insured Individual</li> <li>Self-Funded</li> </ul> <div style="border: 1px solid black; padding: 2px; margin-top: 5px;"><b>Note:</b> At present, the <b>Fully-Insured Individual</b> policy category is not supported in the system.</div>	Yes
Detailed Description	Used to specify additional information about the policy type.	No

**Tip:** Alternatively, you can access this screen by clicking the **Add** button in the **Page Title** area of the **Policy Type** screen.

- Enter the required details in the **Main** section.

**Note:** If you want to create a policy type for the fully-insured health care business, select the **C1-POLICY** business object from the **Policy Business Object** list and the **Fully-Insured Group** option from the **Policy Category** list. However, if you want to create a policy type for the self-funded health care business, select the **C1-ASOPolicy** business object from the **Policy Business Object** list and the **Self-Funded** option from the **Policy Category** list.

- Define the characteristics for the policy type, if required.
- Click **Save**.

The policy type is defined.

### Related Topics

For more information on...	See...
<b>Policy Type</b> screen	<a href="#">Policy Type</a> on page 2061
How to define a characteristic for a policy type	<a href="#">Defining a Characteristic for a Policy Type</a> on page 2065

## Defining a Characteristic for a Policy Type

### Prerequisites

To define a characteristic for a policy type, you should have:

- Characteristic types defined in the application (where the characteristic entity is set to **Policy Type**).

### Procedure

To define a characteristic for a policy type:

- Ensure that the **Characteristics** section is expanded when you are defining, editing, or copying a policy type.

The **Characteristics** section contains the following fields in a grid:

Field Name	Field Description	Mandatory (Yes or No)
Characteristic Type	Used to indicate the characteristic type. <b>Note:</b> The list includes only those characteristic types where the characteristic entity is set to the <b>Policy Type</b> .	Yes (Conditional) <b>Note:</b> This field is required when you are defining a characteristic for the policy type.
Characteristic Value	Used to specify the value for the characteristic type. <b>Note:</b> If you select a predefined characteristic type, the <b>Search</b> (🔍) icon appears corresponding to the <b>Characteristic Value</b> field. On clicking the <b>Search</b> icon, the <b>Predefined Characteristic Search</b> window appears. On specifying the value for a predefined characteristic type, the description of the characteristic value appears corresponding to the <b>Characteristic Value</b> field.	Yes (Conditional) <b>Note:</b> This field is required when you are defining a characteristic for the policy type.

- Enter the required details in the **Characteristics** section.
- If you want to define more than one characteristic for the policy type, click the **Add** (+) icon and then repeat step 2.

**Note:** However, if you want to remove a characteristic from the policy type, click the **Delete** (🗑️) icon corresponding to the characteristic.

### Related Topics

For more information on...	See...
How to define a policy type	<a href="#">Defining a Policy Type</a> on page 2064
How to edit a policy type	<a href="#">Editing a Policy Type</a> on page 2066
How to copy a policy type	<a href="#">Copying a Policy Type</a> on page 2068

## Editing a Policy Type

### Prerequisites

To edit a policy type, you should have:

- Required policy business object defined in the application

**Note:** The **C1-POLICY** and **C1-ASOPolicy** business objects are shipped with the product. You can use the **C1-POLICY** business object to create a fully-insured policy and the **C1-ASOPolicy** business object to create a self-funded policy.

### Procedure

To edit a policy type:

1. Click the **Admin** link in the **Application** toolbar.  
A list appears.
2. From the **Admin** menu, select **P** and then click **Policy Type**.  
A sub-menu appears.
3. Click the **Search** option from the **Policy Type** sub-menu.  
The **Policy Type** screen appears.
4. In the **Policy Type List** zone, click the **Edit** (✎) icon in the **Edit** column corresponding to the policy type whose details you want to edit.

The **Policy Type** screen appears. It contains the following sections:

- **Main** - Used to specify basic details about the policy type.
- **Characteristics** - Used to define characteristics for the policy type.

The **Main** section contains the following fields:

Field Name	Field Description	Mandatory (Yes or No)
Policy Type	Displays the policy type.	Not applicable
Business Object	Indicates the business object using which you are defining the policy type.	Not applicable
Policy Business Object	Used to indicate the business object using which you want to create a policy.	Yes
Description	Used to specify the description for the policy type.	Yes
Status	Used to indicate the status of the policy type. The valid values are: <ul style="list-style-type: none"> <li>• Active</li> <li>• Inactive</li> </ul>	Yes
Policy Category	Used to indicate the category to which the policy type belongs. The valid values are: <ul style="list-style-type: none"> <li>• Fully-Insured Group</li> <li>• Fully-Insured Individual</li> <li>• Self-Funded</li> </ul> <div style="border: 1px solid black; padding: 2px; margin-top: 5px;"> <b>Note:</b> At present, the <b>Fully-Insured Individual</b> policy category is not supported in the system. </div>	Yes
Detailed Description	Used to specify additional information about the policy type.	No

**Tip:** Alternatively, you can edit the details of a policy type by clicking the **Edit** button in the **Policy Type** zone.

5. Modify the required details in the **Main** section.
6. Define, edit, or remove characteristics from the policy type, if required.
7. Click **Save**.

The changes made to the policy type are saved.

**Related Topics**

For more information on...	See...
<b>Policy Type</b> screen	<a href="#">Policy Type</a> on page 2061
<b>Policy Type List</b> zone	<a href="#">Policy Type List</a> on page 2062
<b>Policy Type</b> zone	<a href="#">Policy Type</a> on page 2062
How to define a characteristic for a policy type	<a href="#">Defining a Characteristic for a Policy Type</a> on page 2065

**Copying a Policy Type**

Instead of creating a policy type from scratch, you can create a new policy type using an existing policy type. This is possible through copying a policy type. On copying a policy type, the details including the characteristics are copied to the new policy type. You can then edit the details, if required.

**Prerequisites**

To copy a policy type, you should have:

- Policy type (whose copy you want to create) defined in the application
- Required policy business object defined in the application

**Note:** The **C1-POLICY** and **C1-ASOPolicy** business objects are shipped with the product. You can use the **C1-POLICY** business object to create a fully-insured policy and the **C1-ASOPolicy** business object to create a self-funded policy.

**Procedure**

To copy a policy type:

1. Click the **Admin** link in the **Application** toolbar.  
A list appears.
2. From the **Admin** menu, select **P** and then click **Policy Type**.  
A sub-menu appears.
3. Click the **Search** option from the **Policy Type** sub-menu.  
The **Policy Type** screen appears.
4. In the **Policy Type List** zone, click the **Duplicate** () icon in the **Duplicate** column corresponding to the policy type whose copy you want to create.

The **Policy Type** screen appears. It contains the following sections:

- **Main** - Used to specify basic details about the policy type.
- **Characteristics** - Used to define characteristics for the policy type.

The **Main** section contains the following fields:

Field Name	Field Description	Mandatory (Yes or No)
Policy Type	Used to specify the policy type.	Yes
Business Object	Indicates the business object using which you are defining the policy type.	Not applicable

Field Name	Field Description	Mandatory (Yes or No)
Policy Business Object	Used to indicate the business object using which you want to create a policy.	Yes
Description	Used to specify the description for the policy type.	Yes
Status	Used to indicate the status of the policy type. The valid values are: <ul style="list-style-type: none"> <li>Active</li> <li>Inactive</li> </ul>	Yes
Policy Category	Used to indicate the category to which the policy type belongs. The valid values are: <ul style="list-style-type: none"> <li>Fully-Insured Group</li> <li>Fully-Insured Individual</li> <li>Self-Funded</li> </ul> <div style="border: 1px solid black; padding: 2px; margin-top: 5px;"> <b>Note:</b> At present, the <b>Fully-Insured Individual</b> policy category is not supported in the system. </div>	Yes
Detailed Description	Used to specify additional information about the policy type.	No

**Tip:** Alternatively, you can copy a policy type by clicking the **Duplicate** button in the **Policy Type** zone.

- Enter the required details in the **Main** section.
- Define, edit, or remove characteristics from the policy type, if required.
- Click **Save**.

The new policy type is defined.

### Related Topics

For more information on...	See...
<b>Policy Type</b> screen	<a href="#">Policy Type</a> on page 2061
<b>Policy Type List</b> zone	<a href="#">Policy Type List</a> on page 2062
<b>Policy Type</b> zone	<a href="#">Policy Type</a> on page 2062
How to define a characteristic for a policy type	<a href="#">Defining a Characteristic for a Policy Type</a> on page 2065

## Deleting a Policy Type

### Procedure

To delete a policy type:

- Click the **Admin** link in the **Application** toolbar.  
A list appears.
- From the **Admin** menu, select **P** and then click **Policy Type**.

A sub-menu appears.

- Click the **Search** option from the **Policy Type** sub-menu.

The **Policy Type** screen appears.

- In the **Policy Type List** zone, click the **Delete** () icon in the **Delete** column corresponding to the policy type that you want to delete.

A message appears confirming whether you want to delete the policy type.

**Note:** You can delete a policy type only when a policy is not created using the policy type.

**Tip:** Alternatively, you can delete a policy type by clicking the **Delete** button in the **Policy Type** zone.

- Click **OK**.

The policy type is deleted.

### **Related Topics**

<b>For more information on...</b>	<b>See...</b>
<b>Policy Type</b> screen	<a href="#">Policy Type</a> on page 2061
<b>Policy Type List</b> zone	<a href="#">Policy Type List</a> on page 2062
<b>Policy Type</b> zone	<a href="#">Policy Type</a> on page 2062

## **Viewing the Policy Type Details**

### **Procedure**

To view the details of a policy type:

- Click the **Admin** link in the **Application** toolbar.

A list appears.

- From the **Admin** menu, select **P** and then click **Policy Type**.

A sub-menu appears.

- Click the **Search** option from the **Policy Type** sub-menu.

The **Policy Type** screen appears.

- In the **Policy Type List** zone, click the **Broadcast** () icon corresponding to the policy type whose details you want to view.

The **Policy Type** zone appears.

- View the details of the policy type in the **Policy Type** zone.

### **Related Topics**

<b>For more information on...</b>	<b>See...</b>
<b>Policy Type</b> screen	<a href="#">Policy Type</a> on page 2061
<b>Policy Type List</b> zone	<a href="#">Policy Type List</a> on page 2062
<b>Policy Type</b> zone	<a href="#">Policy Type</a> on page 2062

## Policy Person Role

Oracle Revenue Management and Billing enables you to specify the role of a person while associating the person to a policy. This helps to indicate whether the person is a policy holder, broker, underwriter, and so on in a policy. The **Policy Person Role** screen allows you to define, edit, and delete a policy person role. It contains the following zone:

- [Policy Person Role List](#) on page 2071

### Policy Person Role List

The **Policy Person Role List** zone lists the roles which you can assign to a person in a policy. It contains the following columns:

Column Name	Column Description
Policy Person Role	Displays the policy person role.
Description	Displays the description of the policy person role.
Edit	On clicking the <b>Edit</b> (✎) icon, the <b>Policy Person Role</b> screen appears where you can edit the details of the policy person role.
Delete	On clicking the <b>Delete</b> (🗑) icon, you can delete the policy person role.  <b>Note:</b> You can delete a policy person role only when it is not used while associating a person with a policy.

You can define a new policy person role by clicking the **Add** link in the upper-right corner of this zone.

You can filter the list using various search criteria (such as **Policy Person Role** and **Description**) available in the **Filter** area. By default, the **Filter** area is hidden. You can view the **Filter** area by clicking the **Filters** (✖) icon in the upper-right corner of this zone.

You can change the layout of this zone. For more information on how to change the layout, see [Changing the Layout](#) on page 2882.

#### Related Topics

For more information on...	See...
How to define a policy person role	<a href="#">Defining a Policy Person Role</a> on page 2071
How to edit a policy person role	<a href="#">Editing a Policy Person Role</a> on page 2072
How to delete a policy person role	<a href="#">Deleting a Policy Person Role</a> on page 2073

## Defining a Policy Person Role

### Procedure

To define a policy person role:

1. Click the **Admin** link in the **Application** toolbar.  
A list appears.
2. From the **Admin** menu, select **P** and then click **Policy Person Role**.  
The **Policy Person Role** screen appears.

- Click the **Add** link in the upper-right corner of the **Policy Person Role List** zone.

The **Policy Person Role** screen appears. It contains the following fields:

Field Name	Field Description	Mandatory (Yes or No)
Policy Person Role	Used to specify the policy person role.	Yes
Description	Used to specify the description for the policy person role.	Yes

- Enter the required details in the **Policy Person Role** screen.
- Click **Save**.

The policy person role is defined.

### Related Topics

For more information on...	See...
<b>Policy Person Role</b> screen	<a href="#">Policy Person Role</a> on page 2071
<b>Policy Person Role List</b> zone	<a href="#">Policy Person Role List</a> on page 2071

## Editing a Policy Person Role

### Procedure

To edit a policy person role:

- Click the **Admin** link in the **Application** toolbar.  
A list appears.
- From the **Admin** menu, select **P** and then click **Policy Person Role**.  
The **Policy Person Role** screen appears.
- In the **Policy Person Role List** zone, click the **Edit** (✎) icon in the **Edit** column corresponding to the policy person role whose details you want to edit.

The **Policy Person Role** screen appears. It contains the following fields:

Field Name	Field Description	Mandatory (Yes or No)
Policy Person Role	Displays the policy person role.	Not applicable
Description	Used to specify the description for the policy person role.	Yes

- Modify the required details in the **Policy Person Role** screen.
- Click **Save**.

The changes made to the policy person role are saved.

### Related Topics

For more information on...	See...
<b>Policy Person Role</b> screen	<a href="#">Policy Person Role</a> on page 2071
<b>Policy Person Role List</b> zone	<a href="#">Policy Person Role List</a> on page 2071



## Deleting a Policy Person Role

### Procedure

To delete a policy person role:

1. Click the **Admin** link in the **Application** toolbar.  
A list appears.
2. From the **Admin** menu, select **P** and then click **Policy Person Role**.  
The **Policy Person Role** screen appears.
3. In the **Policy Person Role List** zone, click the **Delete** (🗑️) icon in the **Delete** column corresponding to the policy person role that you want to delete.

A message appears confirming whether you want to delete the policy person role.

**Note:** You can delete a policy person role only when it is not used while associating a person with a policy.

4. Click **OK**.

The policy person role is deleted.

### Related Topics

For more information on...	See...
<b>Policy Person Role</b> screen	<a href="#">Policy Person Role</a> on page 2071
<b>Policy Person Role List</b> zone	<a href="#">Policy Person Role List</a> on page 2071

## Contract Relationship Type

Oracle Revenue Management and Billing enables you to define various relationship types using which you can relate main subscriber and other dependent persons in a membership. The **Contract Relationship Type** screen allows you to define, edit, and delete such relationship types. It also allows you to filter the contract relationship types using various search criteria.

### Filtering the Contract Relationship Types

#### Prerequisites

To filter the contract relationship types, you should have:

- Contract relationship types defined in the application

#### Procedure

To filter the contract relationship types:

1. Click the **Admin** link in the **Application** toolbar.  
A list appears.
2. From the **Admin** menu, select **C** and then click **Contract Relationship Type**.

The **Contract Relationship Type** screen appears. It contains the following field:

Field Name	Field Description	Mandatory (Yes or No)
Relationship Type	Used to search a particular contract relationship type.	Yes

- Enter the search criteria in the **Relationship Type** field.

**Note:** ORMB search engine supports wildcard search, where you can substitute the percentage (%) symbol as a stand in for any word or letter in a search criteria. You can use the ‘%’ wildcard character in all input fields except the date and ID fields. The ‘%’ wildcard character is suffixed automatically at the end of the partial search criteria. Therefore, you may or may not specify the wildcard character at the end of the partial search criteria. However, you have to prefix the wildcard character manually wherever required.

- Click **Search**.

The search results are filtered based on the specified criteria.

#### **Related Topics**

For more information on...	See...
<b>Contract Relationship Type</b> screen	<a href="#">Contract Relationship Type</a> on page 2073

## Defining a Contract Relationship Type

### **Procedure**

To define a contract relationship type:

- Click the **Admin** link in the **Application** toolbar.

A list appears.

- From the **Admin** menu, select **C** and then click **Contract Relationship Type**.

The **Contract Relationship Type** screen appears. It contains the following fields in a grid:

Field Name	Field Description	Mandatory (Yes or No)
Relationship Type	Used to specify the contract relationship type.	Yes
Description	Used to specify the description for the contract relationship type.	Yes

- Enter the required details in the **Contract Relationship Type** screen.
- If you want to define more than one contract relationship type, click the **Add** (+) icon and then repeat step 3.

**Note:** However, if you want to remove a contract relationship type, click the **Delete** (🗑️) icon corresponding to the contract relationship type.

- Click **Save**.

The contract relationship type is defined.

#### **Related Topics**

For more information on...	See...
<b>Contract Relationship Type</b> screen	<a href="#">Contract Relationship Type</a> on page 2073

## Editing a Contract Relationship Type

### **Procedure**

To edit a contract relationship type:

1. Click the **Admin** link in the **Application** toolbar.  
A list appears.
2. From the **Admin** menu, select **C** and then click **Contract Relationship Type**.

The **Contract Relationship Type** screen appears.

3. If required, you can filter the list in the **Contract Relationship Type** screen.

A list of contract relationship types that meet the search criteria appears in the search results. The **Search Results** section contains the following fields in a grid:

Field Name	Field Description	Mandatory (Yes or No)
Relationship Type	Displays the contract relationship type.	Not applicable
Description	Used to specify the description for the contract relationship type.	Yes

4. Modify the required details in the **Contract Relationship Type** screen.
5. Click **Save**.

The changes made to the contract relationship type are saved.

#### **Related Topics**

For more information on...	See...
<b>Contract Relationship Type</b> screen	<a href="#">Contract Relationship Type</a> on page 2073
How to filter the contract relationship types	<a href="#">Filtering the Contract Relationship Types</a> on page 2073

## **Deleting a Contract Relationship Type**

### **Procedure**

To delete a contract relationship type:

1. Click the **Admin** link in the **Application** toolbar.  
A list appears.
2. From the **Admin** menu, select **C** and then click **Contract Relationship Type**.  
The **Contract Relationship Type** screen appears.
3. If required, you can filter the list in the **Contract Relationship Type** screen.  
A list of contract relationship types that meet the search criteria appears in the **Search Results** section.
4. Click the **Delete** (🗑️) icon corresponding to the contract relationship type that you want to delete.

**Note:** You can delete a contract relationship type only when it is not yet used in the system.

5. Click **Save**.

The contract relationship type is deleted.

### **Related Topics**

For more information on...	See...
<b>Contract Relationship Type</b> screen	<a href="#">Contract Relationship Type</a> on page 2073
How to filter the contract relationship types	<a href="#">Filtering the Contract Relationship Types</a> on page 2073

## Source System Extendable Lookup

Oracle Revenue Management and Billing enables you to track the external system from where the fully-insured or self-funded policies are received for billing. Each external system must be defined in the system using the **Source System (C1-SourceSystemLookup)** extendable lookup.

The **Extendable Lookup Query** screen allows you to search for an extendable lookup. It contains the following zone:

- [Extendable Lookup Search](#) on page 2076

### Extendable Lookup Search

The **Extendable Lookup Search** zone allows you to search for an extendable lookup. It contains the following two sections:

- **Search Criteria** – The **Search Criteria** section contains the following fields:

Field Name	Field Description	Mandatory (Yes or No)
Business Object	Used to search a particular extendable lookup business object.	No
Description	Used to search extendable lookups with a particular description.	No

**Note:** You must specify at least one search criterion while searching for an extendable lookup.

- **Search Results** – On clicking the **Search** button, the search results appear based on the specified search criteria. The **Search Results** section contains the following columns:

Column Name	Column Description
Business Object	Displays the extendable lookup business object.
Description	Displays the description of the extendable lookup business object.

**Note:** It has a link. On clicking the link, the **Extendable Lookup** screen appears where you can view the details of the respective extendable lookup.

### Related Topics

For more information on...	See...
How to search for the <b>Source System</b> extendable lookup	<a href="#">Searching for the Source System Extendable Lookup</a> on page 2077
How to view the values of the <b>Source System</b> extendable lookup	<a href="#">Viewing the Values of the Source System Extendable Lookup</a> on page 2077

## Searching for the Source System Extendable Lookup

### Procedure

To search for the **Source System** extendable lookup:

1. Click the **Admin** link in the **Application** toolbar.  
A list appears.
2. From the **Admin** menu, select **E** and then click **Extendable Lookup**.  
The **Extendable Lookup Query** screen appears.
3. In the **Extendable Lookup Search** zone, enter **C1-SourceSystemLookup** in the **Business Object** field.

**Note:** ORMB search engine supports wildcard search, where you can substitute the percentage (%) symbol as a stand in for any word or letter in a search criteria. You can use the ‘%’ wildcard character in all input fields except the date and ID fields. The ‘%’ wildcard character is suffixed automatically at the end of the partial search criteria. Therefore, you may or may not specify the wildcard character at the end of the partial search criteria. However, you have to prefix the wildcard character manually wherever required.

4. Click **Search**.

The **Source System** extendable lookup business object appears in the **Search Results** section.

### Related Topics

For more information on...	See...
Extendable Lookup Query screen	<a href="#">Source System Extendable Lookup</a> on page 2076
Extendable Lookup Search zone	<a href="#">Extendable Lookup Search</a> on page 2076

## Viewing the Values of the Source System Extendable Lookup

### Procedure

To view the values of the **Source System** extendable lookup:

1. Search for the **Source System** extendable lookup in the **Extendable Lookup Query** screen.
2. In the **Search Results** section, click the link in the **Description** column corresponding to the extendable lookup business object whose details you want to view.  
The **Extendable Lookup** screen appears.
3. View the values of the **Source System** extendable lookup in the **Extendable Lookup Value List** zone.

### Related Topics

For more information on...	See...
How to search for the <b>Source System</b> extendable lookup	<a href="#">Searching for the Source System Extendable Lookup</a> on page 2077
Extendable Lookup screen	<a href="#">Extendable Lookup (Source System)</a> on page 2078
Extendable Lookup Value List zone	<a href="#">Extendable Lookup Value List</a> on page 2078



## Extendable Lookup (Source System)

The **Extendable Lookup** screen allows you to view the values of the **Source System (C1-SourceSystemLookup)** extendable lookup. It also allows you to define, edit, copy, and delete a source system. It contains the following zones:

- [Extendable Lookup Value List](#) on page 2078
- [Extendable Lookup Value](#) on page 2079

### Extendable Lookup Value List

The **Extendable Lookup Value List** zone lists the values which are already defined for the **Source System** extendable lookup. It contains the following columns:

Column Name	Column Description
Value	Displays the source system.
Description	Displays the description of the source system.
Owner	Indicates who has created the source system. The valid values are: <ul style="list-style-type: none"> <li>• Framework</li> <li>• Base</li> <li>• Customer Modification</li> </ul>
Edit	On clicking the <b>Edit</b> (  ) icon, the <b>Extendable Lookup</b> screen appears where you can edit the details of the source system.
Duplicate	On clicking the <b>Duplicate</b> (  ) icon, the <b>Extendable Lookup</b> screen appears where you can define a new source system using an existing source system.
Delete	On clicking the <b>Delete</b> (  ) icon, you can delete the source system. <div style="border: 1px solid black; padding: 5px; margin-top: 10px;"> <p><b>Note:</b> You can delete a source system only when it is not yet used in the system.</p> </div>
Detailed Description	Displays additional information about the source system.

**Note:** Pagination is used to display limited number of records in this zone. You can use the navigation buttons, such as **Previous** and **Next** to navigate between pages.

On clicking the **Broadcast** () icon corresponding to a source system, the **Extendable Lookup Value** zone appears with the details of the respective source system.

You can filter the list using various search criteria (such as, **Value** and **Description**) available in the **Filter** area. By default, the **Filter** area is hidden. You can view the **Filter** area by clicking the **Filters** () icon in the upper right corner of this zone.

#### Related Topics

For more information on...	See...
How to edit a source system	<a href="#">Editing a Source System</a> on page 2081
How to copy a source system	<a href="#">Copying a Source System</a> on page 2082

For more information on...	See...
How to delete a source system	<a href="#">Deleting a Source System</a> on page 2083
How to view the details of a source system	<a href="#">Viewing the Source System Details</a> on page 2083

## Extendable Lookup Value

The **Extendable Lookup Value** zone displays the details of the source system. It contains the following sections:

- **Main** – Displays basic information about the source system. It contains the following fields:

Field Name	Field Description
Source System	Displays the source system.
Description	Displays the description of the source system.
Override Description	Displays the overridden description of the source system.
Detailed Description	Displays additional information about the source system.
Status	Indicates the status of the source system. The valid values are: <ul style="list-style-type: none"> <li>• Active</li> <li>• Inactive</li> </ul>

- **Record Actions** – This section contains the following buttons:

Button Name	Button Description
Edit	Used to edit the details of the source system.
Delete	Used to delete the source system. <b>Note:</b> You can delete a source system only when it is not yet used in the system.
Duplicate	Used to create a source system using an existing source system.

- **Record Information** – This section contains the following fields:

Field Name	Field Description
Business Object	Indicates the extendable lookup business object using which the source system is created. In addition, a context menu appears corresponding to this field which helps in navigating to other screens in the application. <b>Note:</b> It has a link. On clicking the link, the <b>Business Object</b> screen appears where you can view the details of the respective business object.
Owner	Indicates who has created the source system. The valid values are: <ul style="list-style-type: none"> <li>• Framework</li> <li>• Base</li> <li>• Customer Modification</li> </ul>

By default, the **Extendable Lookup Value** zone does not appear in the **Extendable Lookup** screen. It appears only when you click the **Broadcast**  icon corresponding to the source system in the **Extendable Lookup Value List** zone.

**Related Topics**

For more information on...	See...
How to edit a source system	<a href="#">Editing a Source System</a> on page 2081
How to copy a source system	<a href="#">Copying a Source System</a> on page 2082
How to delete a source system	<a href="#">Deleting a Source System</a> on page 2083
How to view the details of a source system	<a href="#">Viewing the Source System Details</a> on page 2083

**Defining a Source System****Procedure**

To define a source system:

1. Search for the **Source System** extendable lookup in the **Extendable Lookup Query** screen.
2. In the **Search Results** section, click the link in the **Description** column corresponding to the extendable lookup business object whose details you want to view.

The **Extendable Lookup** screen appears.

3. Click the **Add** button in the **Page Title** area of the **Extendable Lookup** screen.

The **Extendable Lookup** screen appears. It contains the following section:

- **Main** – Used to specify basic details about the source system.

The **Main** section contains the following fields:

Field Name	Field Description	Mandatory (Yes or No)
Source System	Used to specify the external system from where the policies are received for billing.	Yes
Description	Used to specify the description for the source system.	Yes
Override Description	Used when you want to override the description of the source system.	No
Detailed Description	Used to specify additional information about the source system.	No
Status	Used to indicate the status of the source system. The valid values are: <ul style="list-style-type: none"> <li>• Active</li> <li>• Inactive</li> </ul> <div style="border: 1px solid black; padding: 2px; margin-top: 5px;"><b>Note:</b> By default, the value is set to <b>Active</b>.</div>	Yes

4. Enter the required details in the **Main** section.
5. Click **Save**.

The source system is added in the **C1-SourceSystemLookup** extendable lookup.

**Related Topics**



For more information on...	See...
How to search for the <b>Source System</b> extendable lookup	<a href="#">Searching for the Source System Extendable Lookup</a> on page 2077
<b>Extendable Lookup</b> screen	<a href="#">Extendable Lookup (Source System)</a> on page 2078

## Editing a Source System

### Procedure

To edit a source system:

1. Search for the **Source System** extendable lookup in the **Extendable Lookup Query** screen.
2. In the **Search Results** section, click the link in the **Description** column corresponding to the extendable lookup business object whose details you want to view.

The **Extendable Lookup** screen appears.

3. In the **Extendable Lookup Value List** zone, click the **Edit** (✎) icon in the **Edit** column corresponding to the source system whose details you want to edit.

The **Extendable Lookup** screen appears. It contains the following section:

- **Main** – Used to specify basic details about the source system.

The **Main** section contains the following fields:

Field Name	Field Description	Mandatory (Yes or No)
Source System	Displays the source system.	Not applicable
Description	Used to specify the description for the source system.	Yes
Override Description	Used when you want to override the description of the source system.	No
Detailed Description	Used to specify additional information about the source system.	No
Status	Used to indicate the status of the source system. The valid values are: <ul style="list-style-type: none"> <li>• Active</li> <li>• Inactive</li> </ul>	Yes

**Tip:** Alternatively, you can edit the details of a source system by clicking the **Edit** button in the **Extendable Lookup Value** zone.

4. Modify the required details in the **Main** section.
5. Click **Save**.

The changes made to the source system are saved.

### Related Topics

For more information on...	See...
How to search for the <b>Source System</b> extendable lookup	<a href="#">Searching for the Source System Extendable Lookup</a> on page 2077
<b>Extendable Lookup</b> screen	<a href="#">Extendable Lookup (Source System)</a> on page 2078

For more information on...	See...
<b>Extendable Lookup Value List</b> zone	<a href="#">Extendable Lookup Value List</a> on page 2078
<b>Extendable Lookup Value</b> zone	<a href="#">Extendable Lookup Value</a> on page 2079

## Copying a Source System

Instead of creating a source system from scratch, you can create a new source system using an existing source system. This is possible through copying a source system. On copying a source system, the details of the source system are copied to the new source system. You can then edit the details, if required.

### Prerequisites

To copy a source system, you should have:

- Source system (whose copy you want to create) defined in the application

### Procedure

To copy a source system:

1. Search for the **Source System** extendable lookup in the **Extendable Lookup Query** screen.
2. In the **Search Results** section, click the link in the **Description** column corresponding to the extendable lookup business object whose details you want to view.

The **Extendable Lookup** screen appears.

3. In the **Extendable Lookup Value List** zone, click the **Duplicate** () icon in the **Duplicate** column corresponding to the source system whose copy you want to create.

The **Extendable Lookup** screen appears. It contains the following section:

- **Main** – Used to specify basic details about the source system.

The **Main** section contains the following fields:

Field Name	Field Description	Mandatory (Yes or No)
Source System	Used to specify the external system from where the policies are received for billing.	Yes
Description	Used to specify the description for the source system.	Yes
Override Description	Used when you want to override the description of the source system.	No
Detailed Description	Used to specify additional information about the source system.	No
Status	Used to indicate the status of the source system. The valid values are: <ul style="list-style-type: none"> <li>• Active</li> <li>• Inactive</li> </ul>	Yes

**Tip:** Alternatively, you can copy a source system by clicking the **Duplicate** button in the **Extendable Lookup Value** zone.

4. Enter the required details in the **Main** section.
5. Click **Save**.

The new source system is added in the **C1-SourceSystemLookup** extendable lookup.

## Related Topics

For more information on...	See...
How to search for the <b>Source System</b> extendable lookup	<a href="#">Searching for the Source System Extendable Lookup</a> on page 2077
<b>Extendable Lookup</b> screen	<a href="#">Extendable Lookup (Source System)</a> on page 2078
<b>Extendable Lookup Value List</b> zone	<a href="#">Extendable Lookup Value List</a> on page 2078
<b>Extendable Lookup Value</b> zone	<a href="#">Extendable Lookup Value</a> on page 2079

## Deleting a Source System

### Procedure

To delete a source system:

1. Search for the **Source System** extendable lookup in the **Extendable Lookup Query** screen.
2. In the **Search Results** section, click the link in the **Description** column corresponding to the extendable lookup business object whose details you want to view.

The **Extendable Lookup** screen appears.

3. In the **Extendable Lookup Value List** zone, click the **Delete** (🗑️) icon in the **Delete** column corresponding to the source system that you want to delete.

A message appears confirming whether you want to delete the source system.

**Note:** You can delete a source system only when it is not yet used in the system.

**Tip:** Alternatively, you can delete a source system by clicking the **Delete** button in the **Extendable Lookup Value** zone.

4. Click **OK**.

The source system is deleted from the **C1-SourceSystemLookup** extendable lookup.

## Related Topics

For more information on...	See...
How to search for the <b>Source System</b> extendable lookup	<a href="#">Searching for the Source System Extendable Lookup</a> on page 2077
<b>Extendable Lookup</b> screen	<a href="#">Extendable Lookup (Source System)</a> on page 2078
<b>Extendable Lookup Value List</b> zone	<a href="#">Extendable Lookup Value List</a> on page 2078
<b>Extendable Lookup Value</b> zone	<a href="#">Extendable Lookup Value</a> on page 2079

## Viewing the Source System Details

### Procedure

To view the details of a source system:

1. Search for the **Source System** extendable lookup in the **Extendable Lookup Query** screen.
2. In the **Search Results** section, click the link in the **Description** column corresponding to the extendable lookup business object whose details you want to view.

The **Extendable Lookup** screen appears.

3. In the **Extendable Lookup Value List** zone, click the **Broadcast**  icon corresponding to the source system whose details you want to view.  
The **Extendable Lookup Value** zone appears.
4. View the details of the source system in the **Extendable Lookup Value** zone.

### **Related Topics**

For more information on...	See...
How to search for the <b>Source System</b> extendable lookup	<a href="#">Searching for the Source System Extendable Lookup</a> on page 2077
<b>Extendable Lookup</b> screen	<a href="#">Extendable Lookup (Source System)</a> on page 2078
<b>Extendable Lookup Value List</b> zone	<a href="#">Extendable Lookup Value List</a> on page 2078
<b>Extendable Lookup Value</b> zone	<a href="#">Extendable Lookup Value</a> on page 2079

## **Policy (Used for Searching)**

The **Policy** screen allows you to search for a policy using various search criteria. It also allows you to define a policy. It contains the following zone:

- [Search Policy](#) on page 2084

Through this screen, you can navigate to the following screen:

- [Policy \(Used for Viewing\)](#) on page 2095

## **Search Policy**

The **Search Policy** zone allows you to search for a policy using various search criteria. It contains the following two sections:

- **Search Criteria** - The **Search Criteria** section contains the following fields:

Field Name	Field Description	Mandatory (Yes or No)
Search By	Used to indicate whether you want to search for a policy using the policy or person details. The valid values are: <ul style="list-style-type: none"> <li>• Policy Date/Policy Type/Status</li> <li>• Source System/Policy Number/Description</li> <li>• Person Name/Person Identifier</li> </ul> <div style="border: 1px solid black; padding: 2px; margin-top: 5px;"><b>Note:</b> By default, the <b>Policy Date/Policy Type/Status</b> option is selected.</div>	Yes
Policy Type	Used to search policies which are created using a particular policy type. <div style="border: 1px solid black; padding: 2px; margin-top: 5px;"><b>Note:</b> This field appears only when the <b>Policy Date/Policy Type/Status</b> option is selected from the <b>Search By</b> list.</div>	No

Field Name	Field Description	Mandatory (Yes or No)
Start Date	<p>Used to search policies which are effective from a particular date.</p> <p><b>Note:</b> This field appears only when the <b>Policy Date/Policy Type/Status</b> option is selected from the <b>Search By</b> list.</p>	No
Status	<p>Used to search policies with a particular status. The valid values are:</p> <ul style="list-style-type: none"> <li>• In Force/Active</li> <li>• Canceled</li> <li>• Pending Cancellation</li> <li>• Pending</li> <li>• Pending Reinstatement</li> <li>• Pending Termination</li> <li>• Pending Termination Overridden</li> <li>• Post Runout</li> <li>• Reinstated</li> <li>• Runout</li> <li>• Terminated</li> </ul> <p><b>Note:</b> This field appears only when the <b>Policy Date/Policy Type/Status</b> option is selected from the <b>Search By</b> list.</p>	No
End Date	<p>Used to search policies which are effective till a particular date.</p> <p><b>Note:</b> This field appears only when the <b>Policy Date/Policy Type/Status</b> option is selected from the <b>Search By</b> list.</p>	No
Source System	<p>Used to search policies which originated from a particular external system.</p> <p><b>Note:</b> This field appears only when the <b>Source System/Policy Number/Description</b> option is selected from the <b>Search By</b> list.</p>	No
Policy Number	<p>Used to search a policy with a particular policy number.</p> <p><b>Note:</b> This field appears only when the <b>Source System/Policy Number/Description</b> option is selected from the <b>Search By</b> list.</p>	No
Description	<p>Used to search policies with a particular description.</p> <p><b>Note:</b> This field appears only when the <b>Source System/Policy Number/Description</b> option is selected from the <b>Search By</b> list.</p>	No
Person Name	<p>Used to search policies to which a particular person is associated.</p> <p><b>Note:</b> This field appears only when the <b>Person Name/Person Identifier</b> option is selected from the <b>Search By</b> list.</p>	No

Field Name	Field Description	Mandatory (Yes or No)
Person Identifier Type	Used to indicate the person identifier type. <b>Note:</b> This field appears only when the <b>Person Name/Person Identifier</b> option is selected from the <b>Search By</b> list.	Yes (Conditional) <b>Note:</b> If you specify the person identifier as a search criteria, you have to select the person identifier type.
Person Identifier	Used to search policies to which a person is associated. <b>Note:</b> This field appears only when the <b>Person Name/Person Identifier</b> option is selected from the <b>Search By</b> list.	Yes (Conditional) <b>Note:</b> If you specify the person identifier type as a search criteria, you have to specify the person identifier.

**Note:** You must specify at least one search criterion while searching for a policy.

- **Search Results** - On clicking the **Search** button, the search results appear based on the specified search criteria. The **Search Results** section contains the following columns:

Column Name	Column Description
Policy Number	Displays the policy number.
Policy Information	Displays additional information about the policy. <b>Note:</b> It has a link. On clicking the link, the <b>Policy</b> screen appears where you can view the details of the respective policy.
Source System	Indicates the external system from where the policy is originated.
Description	Displays the description of the policy.
Start Date	Displays the date from when the policy is effective.
End Date	Displays the date till when the policy is effective.

Column Name	Column Description						
Status	<p>Indicates the status of the policy. If the policy is created using the <b>C1-POLICY</b> business object, the valid values are:</p> <ul style="list-style-type: none"> <li>• Pending</li> <li>• In Force/Active</li> <li>• Pending Cancellation</li> <li>• Canceled</li> <li>• Pending Reinstatement</li> <li>• Reinstated</li> <li>• Pending Termination</li> <li>• Pending Termination Overridden</li> <li>• Terminated</li> </ul> <p>However, if the policy is created using the <b>C1-ASOPolicy</b> business object, the valid values are:</p> <ul style="list-style-type: none"> <li>• Pending</li> <li>• In Force/Active</li> <li>• Runout</li> <li>• Post Runout</li> </ul>						
Main Customer	<p>This column displays different data depending on whether you search for a policy using the policy or person details. The following table describes this column:</p> <table border="1" data-bbox="578 1083 1468 1766"> <thead> <tr> <th data-bbox="578 1083 1019 1136">If you search for a policy using...</th> <th data-bbox="1019 1083 1468 1136">Then...</th> </tr> </thead> <tbody> <tr> <td data-bbox="578 1136 1019 1514">The <b>Policy Date/Policy Type/Status</b> or <b>Source System/Policy Number/Description</b> option</td> <td data-bbox="1019 1136 1468 1514"> <p>The <b>Main Customer</b> column displays the name of the person who is the main customer of the policy. In addition, this column has a context menu which helps in navigating to other screens in the application.</p> <div style="border: 1px solid black; padding: 5px; margin-top: 10px;"> <p><b>Note:</b> It has a link. On clicking the link, the <b>Person</b> screen appears where you can view the details of the respective person.</p> </div> </td> </tr> <tr> <td data-bbox="578 1514 1019 1766">The <b>Person Name/Person Identifier</b> option</td> <td data-bbox="1019 1514 1468 1766"> <p>The <b>Main Customer</b> column indicates whether the person is the main customer of the policy. The valid values are:</p> <ul style="list-style-type: none"> <li>• Y</li> <li>• N</li> </ul> </td> </tr> </tbody> </table>	If you search for a policy using...	Then...	The <b>Policy Date/Policy Type/Status</b> or <b>Source System/Policy Number/Description</b> option	<p>The <b>Main Customer</b> column displays the name of the person who is the main customer of the policy. In addition, this column has a context menu which helps in navigating to other screens in the application.</p> <div style="border: 1px solid black; padding: 5px; margin-top: 10px;"> <p><b>Note:</b> It has a link. On clicking the link, the <b>Person</b> screen appears where you can view the details of the respective person.</p> </div>	The <b>Person Name/Person Identifier</b> option	<p>The <b>Main Customer</b> column indicates whether the person is the main customer of the policy. The valid values are:</p> <ul style="list-style-type: none"> <li>• Y</li> <li>• N</li> </ul>
If you search for a policy using...	Then...						
The <b>Policy Date/Policy Type/Status</b> or <b>Source System/Policy Number/Description</b> option	<p>The <b>Main Customer</b> column displays the name of the person who is the main customer of the policy. In addition, this column has a context menu which helps in navigating to other screens in the application.</p> <div style="border: 1px solid black; padding: 5px; margin-top: 10px;"> <p><b>Note:</b> It has a link. On clicking the link, the <b>Person</b> screen appears where you can view the details of the respective person.</p> </div>						
The <b>Person Name/Person Identifier</b> option	<p>The <b>Main Customer</b> column indicates whether the person is the main customer of the policy. The valid values are:</p> <ul style="list-style-type: none"> <li>• Y</li> <li>• N</li> </ul>						

Column Name	Column Description
Person Information	<p>Indicates the person who is associated with the policy. In addition, this column has a context menu which helps in navigating to other screens in the application.</p> <p><b>Note:</b></p> <p>It has a link. On clicking the link, the <b>Person</b> screen appears where you can view the details of the respective person.</p> <p>This column appears only when the <b>Person Name/Person Identifier</b> option is selected from the <b>Search By</b> list.</p>
Policy Person Role	<p>Indicates the role using which the person is associated with the policy.</p> <p><b>Note:</b> This column appears only when the <b>Person Name/Person Identifier</b> option is selected from the <b>Search By</b> list.</p>

**Note:** Pagination is used to display limited number of records in the **Search Results** section. You can use the navigation links, such as **Previous** and **Next** to navigate between pages.

### **Related Topics**

For more information on...	See...
How to search for a policy	<a href="#">Searching for a Policy</a> on page 2088
How to define a policy	<a href="#">Defining a Policy</a> on page 2089
How to view the details of a policy	<a href="#">Viewing the Policy Details</a> on page 2089

## **Searching for a Policy**

### **Prerequisites**

To search for a policy, you should have:

- Policy types and person identifier types defined in the application
- Values defined for the **C1-SourceSystemLookup** extendable lookup

### **Procedure**

To search for a policy:

1. Click the **Menu** link in the **Application** toolbar.  
A list appears.
2. From the **Main** menu, select **Person Information** and then click **Policy**.  
A sub-menu appears.
3. Click the **Search** option from the **Policy** sub-menu.  
The **Policy** screen appears.
4. Enter the search criteria in the **Search Policy** zone.



**Note:** ORMB search engine supports wildcard search, where you can substitute the percentage (%) symbol as a stand in for any word or letter in a search criteria. You can use the ‘%’ wildcard character in all input fields except the date and ID fields. The ‘%’ wildcard character is suffixed automatically at the end of the partial search criteria. Therefore, you may or may not specify the wildcard character at the end of the partial search criteria. However, you have to prefix the wildcard character manually wherever required.

5. Click **Search**.

A list of policies that meet the search criteria appears in the **Search Results** section.

**Related Topics**

For more information on...	See...
Policy screen	<a href="#">Policy (Used for Viewing)</a> on page 2095
Search Policy zone	<a href="#">Search Policy</a> on page 2084

## Viewing the Policy Details

**Procedure**

To view the details of a policy:

1. Search for the policy in the **Policy** screen.
2. In the **Search Results** section, click the link in the **Policy Information** column corresponding to the policy whose details you want to view.

The **Policy** screen appears.

3. Ensure that the **Main** tab is selected.
4. View the details of the policy in the **Policy** zone.

**Related Topics**

For more information on...	See...
How to search for a policy	<a href="#">Searching for a Policy</a> on page 2088
Policy screen	<a href="#">Policy (Used for Viewing)</a> on page 2095
Policy zone	<a href="#">Policy</a> on page 2095

## Defining a Policy

Oracle Revenue Management and Billing enables you to define a policy for the fully-insured and self-funded health care business. You can define a fully-insured policy using a policy type where the policy category is set to **Fully-Insured Group** or **Fully-Insured Individual**. However, you can define a self-funded policy using a policy type where the policy category is set to **Self-Funded**.

**Note:** At present, the **Fully-Insured Individual** policy category is not supported in the system.

**Prerequisites**

To define a policy, you should have:

- Policy types defined in the application
- Values defined for the **C1-SourceSystemLookup** extendable lookup

**Note:** This prerequisite is applicable only when you want to define a fully-insured policy.

- Values defined for the **RUNOUT\_ADM\_OPT\_FLG** lookup field

**Note:** This prerequisite is applicable only when you want to define a self-funded policy.

### Procedure

To define a policy:

1. Click the **Menu** link in the **Application** toolbar.  
A list appears.
2. From the **Main** menu, select **Person Information** and then click **Policy**.  
A sub-menu appears.
3. Click the **Add** option from the **Policy** sub-menu.

The **Select Policy Type** screen appears. It contains the following field:

Field Name	Field Description	Mandatory (Yes or No)
Policy Type	Used to indicate the policy type using which you want to create a policy.  <b>Note:</b> If you want to create a fully-insured policy, you must select a policy type where the policy category is set to <b>Fully-Insured Group</b> or <b>Fully-Insured Individual</b> . However, if you want to create a self-funded policy, you must select a policy type where the policy category is set to <b>Self-Funded</b> .	Yes

**Tip:** Alternatively, you can access this screen by clicking the **Add** button in the **Page Title** area of the **Policy** screen.

4. Select the required policy type from the respective field.
5. Click **OK**.

The **Policy** screen appears. It contains the following sections:

- **Main** - Used to specify the basic details about the policy.
- **Persons** - Used to associate persons with the policy.
- **Characteristics** - Used to define characteristics for the policy.

The **Main** section contains the following fields:

Field Name	Field Description	Mandatory (Yes or No)
Policy Type	Indicates the policy type using which you are defining the policy.	Not applicable
Policy Number	Used to specify the policy number.	Yes
Description	Used to specify the description for the policy.	Yes
Source System	Used to indicate the external system from where the policy is originated.  <b>Note:</b> This field appears only when you are defining a policy using a policy type where the policy category is set to <b>Fully-Insured Group</b> or <b>Fully-Insured Individual</b> .	Yes

Field Name	Field Description	Mandatory (Yes or No)
Start Date	Used to specify the date from when the policy is effective.  <b>Note:</b> The policy start date cannot be later than the policy end date.	Yes
End Date	Used to specify the date till when the policy is effective.  <b>Note:</b> The policy end date cannot be earlier than the policy start date.	Yes
Runout End Date	Used to specify the date when the runout period of the self-funded policy ends.  <b>Note:</b> The runout end date cannot be earlier than or equal to the policy end date. This field appears only when you are defining a policy using a policy type where the policy category is set to <b>Self-Funded</b> .	No
Runout Administration Fees	Used to indicate whether the administration fees must be charged when the claim transaction for the self-funded policy is processed in the runout period. The valid values are: <ul style="list-style-type: none"><li>• None</li><li>• Percentage of Claim</li></ul> <b>Note:</b> At present, this field is used only for the informational purposes and is not considered during the billable charge creation for the claim transactions which are received in the runout period of the policy. This field appears only when you are defining a policy using a policy type where the policy category is set to <b>Self-Funded</b> .	No

6. Enter the required details in the **Main** section.
7. Associate the required persons with the policy.

**Note:** While defining a policy, you must associate a person who is the main customer of the policy.

8. Define the characteristics for the policy, if required.
9. Click **Save**.

The policy is defined and its status is set to **Pending**.

### **Related Topics**

For more information on...	See...
Policy screen	<a href="#">Policy (Used for Viewing)</a> on page 2095
How to associate a person with a policy	<a href="#">Associating a Person with a Policy</a> on page 2092
How to define a characteristic for a policy	<a href="#">Defining a Characteristic for a Policy</a> on page 2093

## Associating a Person with a Policy

### Prerequisites

To associate a person with a policy, you should have:

- Required persons defined in the application
- Required policy person roles defined in the application

### Procedure

To associate a person with a policy:

1. Ensure that the **Persons** section is expanded when you are defining or editing a policy.

The **Persons** section contains the following fields in a grid:

Field Name	Field Description	Mandatory (Yes or No)
Person	Used to indicate the person that you want to associate with the policy.  <b>Note:</b> The <b>Search</b>  icon appears corresponding to this field. On clicking the <b>Search</b> icon, the <b>Person Search</b> window appears.  On specifying the person ID, the person name appears corresponding to the <b>Person</b> field.	Yes
Sequence	Used to specify the sequence number for the associated person.	Yes
Policy Person Role	Used to indicate the role of a person in the policy.	Yes
Main Customer	Used to indicate whether the person is the main customer of the policy.  <b>Note:</b> At a time, only one person can be the main customer of the policy.	Yes (Conditional)  <b>Note:</b> You must select this option while associating a person who is the main customer of the policy.

Field Name	Field Description	Mandatory (Yes or No)
Start Date	Used to specify the date from when the person is associated with the policy.  <b>Note:</b> The start date cannot be later than the end date. The start date cannot be earlier than the policy start date and later than the policy end date.	Yes
End Date	Used to specify the date till when the person is associated with the policy.  <b>Note:</b> The end date cannot be earlier than the start date. The end date cannot be earlier than the policy start date and later than the policy end date. This validation is done only when the policy is transition to the status which is not specified in the <b>Skip Status for Policy Person End Date Validation</b> parameter of the <b>C1-POLBOVAL</b> algorithm. For example, if you set the <b>Skip Status for Policy Person End Date Validation</b> parameter of the <b>C1-POLBOVAL</b> algorithm to <b>TERMINATED</b> , the system will not perform this validation when the status of the policy is changed to <b>Terminated</b> .	No

- Enter the required details in the **Persons** section.

**Note:** While associating the persons with a policy, you must always ensure that one person is the main customer of the policy.

- If you want to associate more than one person with the policy, click the **Add** (+) icon and then repeat step 2.

**Note:** However, if you want to dissociate a person from the policy, click the **Delete** (🗑️) icon corresponding to the person.

- Click **Save**.

The persons are associated with the policy.

### Related Topics

For more information on...	See...
How to define a policy	<a href="#">Defining a Policy</a> on page 2089
How to edit a policy	<a href="#">Editing a Policy</a> on page 2105

## Defining a Characteristic for a Policy

### Prerequisites

To define a characteristic for a policy, you should have:

- Characteristic types defined in the application (where the characteristic entity is set to **Policy**)

### Procedure

To define a characteristic for a policy:

1. Ensure that the **Characteristics** section is expanded when you are defining or editing a policy.

The **Characteristics** section contains the following fields in a grid:

Field Name	Field Description	Mandatory (Yes or No)
Effective Date	Used to specify the date from when the characteristic is effective for the policy.  <b>Note:</b> The effective date cannot be earlier than the policy start date and later than the policy end date.	Yes (Conditional)  <b>Note:</b> This field is required when you are defining a characteristic for the policy.
Characteristic Type	Used to indicate the characteristic type.  <b>Note:</b> The list includes only those characteristic types where the characteristic entity is set to <b>Policy</b> .	Yes (Conditional)  <b>Note:</b> This field is required when you are defining a characteristic for the policy.
Characteristic Value	Used to specify the value for the characteristic type.  <b>Note:</b> If you select a predefined characteristic type, the <b>Search</b>  icon appears corresponding to the <b>Characteristic Value</b> field. On clicking the <b>Search</b> icon, the <b>Predefined Characteristic Search</b> window appears.  On specifying the value for a predefined characteristic type, the description of the characteristic value appears corresponding to the <b>Characteristic Value</b> field.	Yes (Conditional)  <b>Note:</b> This field is required when you are defining a characteristic for the policy.

2. Enter the required details in the **Characteristics** section.
3. If you want to define more than one characteristic for the policy, click the **Add**  icon and then repeat step 2.

**Note:** However, if you want to remove a characteristic from the policy, click the **Delete**  icon corresponding to the characteristic.

4. Click **Save**.

The characteristics are defined for the policy.

### Related Topics

For more information on...	See...
How to define a policy	<a href="#">Defining a Policy</a> on page 2089
How to edit a policy	<a href="#">Editing a Policy</a> on page 2105

## Policy (Used for Viewing)

---

The **Policy** screen allows you to:

- View the details of a fully-insured or self-funded policy
- Edit the details of a fully-insured or self-funded policy
- Delete a fully-insured or self-funded policy
- Activate a fully-insured or self-funded policy
- Add or edit plans in a fully-insured policy
- Add memberships to a fully-insured policy plan
- Initiate the termination process for a fully-insured policy
- Terminate a fully-insured policy
- Initiate the cancellation process for a fully-insured policy
- Cancel a fully-insured policy
- Initiate the reinstatement process for a fully-insured policy
- Reinstatement a fully-insured policy
- View the log of a fully-insured or self-funded policy
- Add a log entry for a fully-insured or self-funded policy

It consists of the following tabs:

- [Policy - Main](#) on page 2095
- [Policy - Plan](#) on page 2102
- [Policy - Log](#) on page 2104

### Policy - Main

The **Main** tab displays information about the policy. It contains the following zone:

- [Policy](#) on page 2095

### Policy

The **Policy** zone displays the details of the fully-insured or self-funded policy. It contains the following sections:

- **Main** - Displays basic information about the policy. It contains the following fields:

Field Name	Field Description
Base Policy Information	Displays information about the base policy.  <b>Note:</b> This field appears only when you are viewing the details of a renewed policy which is created using a policy type where the policy category is set to <b>Self-Funded</b> .
Policy Information	Displays information about the policy.
Policy Type	Indicates the policy type using which the policy is created.  <b>Note:</b> It has a link. On clicking the link, the <b>Policy Type</b> screen appears where you can view the details of the respective policy type.

Field Name	Field Description
Status	<p>Indicates the status of the policy. If the policy is created using the <b>C1-POLICY</b> business object, the valid values are:</p> <ul style="list-style-type: none"> <li>• Pending</li> <li>• In Force/Active</li> <li>• Pending Cancellation</li> <li>• Canceled</li> <li>• Pending Reinstatement</li> <li>• Reinstated</li> <li>• Pending Termination</li> <li>• Terminated</li> </ul> <p>However, if the policy is created using the <b>C1-ASOPolicy</b> business object, the valid values are:</p> <ul style="list-style-type: none"> <li>• Pending</li> <li>• In Force/Active</li> <li>• Runout</li> <li>• Post Runout</li> </ul>
Status Reason	<p>Indicates the reason why the policy is terminated.</p> <div style="border: 1px solid black; padding: 5px;"> <p><b>Note:</b></p> <p>It has a link. On clicking the link, the <b>Status Reason</b> screen appears where you can view the details of the respective termination reason.</p> <p>This field appears only when you are viewing the details of a terminated or reinstated policy which is created using a policy type where the policy category is set to <b>Fully-Insured Group</b> or <b>Fully-Insured Individual</b>.</p> </div>
Policy Number	Displays the policy number.
Description	Displays the description of the policy.
Source System	Indicates the external system from where the policy is originated.
Start Date	Displays the date from when the policy is effective.
End Date	Displays the date till when the policy is effective.
Renewal Date	<p>Displays the date when the policy is renewed.</p> <div style="border: 1px solid black; padding: 5px;"> <p><b>Note:</b> This field appears only when you are viewing the details of a policy which is renewed.</p> </div>



Field Name	Field Description																																													
Paid Through Date	<p data-bbox="516 212 1468 275">Indicates the term end date of the last fully or partially paid term. The system considers the term to be fully paid when the threshold limit is met.</p> <div data-bbox="516 289 1468 562" style="border: 1px solid black; padding: 5px;"> <p data-bbox="516 302 581 327"><b>Note:</b></p> <p data-bbox="516 348 1187 373">This field appears only when the following conditions are met:</p> <ul data-bbox="545 394 1468 537" style="list-style-type: none"> <li data-bbox="545 394 1468 485">• When you are viewing the details of a policy which is created using a policy type where the policy category is set to <b>Fully-Insured Group</b> or <b>Fully-Insured Individual</b>.</li> <li data-bbox="545 506 1219 537">• When the paid through date is calculated at the policy level.</li> </ul> </div> <p data-bbox="516 583 1468 646">The paid through date is calculated while freezing or canceling a payment or adjustment depending on whether the required algorithm is attached to the respective system event:</p> <table border="1" data-bbox="516 667 1468 919"> <thead> <tr> <th data-bbox="516 667 781 716">Entity</th> <th data-bbox="781 667 1166 716">System Event</th> <th data-bbox="1166 667 1468 716">Algorithm</th> </tr> </thead> <tbody> <tr> <td data-bbox="516 716 781 764">Customer Class</td> <td data-bbox="781 716 1166 764">Payment Freeze</td> <td data-bbox="1166 716 1468 764">C1-PSPTDCAL</td> </tr> <tr> <td data-bbox="516 764 781 812">Customer Class</td> <td data-bbox="781 764 1166 812">Payment Cancellation</td> <td data-bbox="1166 764 1468 812">C1-PXPTDCAL</td> </tr> <tr> <td data-bbox="516 812 781 861">Adjustment Type</td> <td data-bbox="781 812 1166 861">Adjustment Freeze</td> <td data-bbox="1166 812 1468 861">C1-ADPTDCAL</td> </tr> <tr> <td data-bbox="516 861 781 909">Adjustment Type</td> <td data-bbox="781 861 1166 909">Adjustment Cancellation</td> <td data-bbox="1166 861 1468 909">C1-AXPTDCAL</td> </tr> </tbody> </table> <p data-bbox="516 940 1468 1003">The following table indicates when the paid through date is calculated at the policy and/or membership level:</p> <table border="1" data-bbox="516 1024 1468 1976"> <thead> <tr> <th data-bbox="516 1024 716 1234">If the Paid Through Date Calculation Level parameter is set to...</th> <th data-bbox="716 1024 1003 1234">If the following characteristics are defined for the billable charge or adjustment...</th> <th data-bbox="1003 1024 1468 1234">Then...</th> </tr> </thead> <tbody> <tr> <td data-bbox="516 1234 716 1318">P</td> <td data-bbox="716 1234 1003 1318">C1-POLID</td> <td data-bbox="1003 1234 1468 1318">Paid through date is calculated at the policy level</td> </tr> <tr> <td data-bbox="516 1318 716 1402">P</td> <td data-bbox="716 1318 1003 1402">C1-MPID</td> <td data-bbox="1003 1318 1468 1402">Paid through date is calculated at the policy level</td> </tr> <tr> <td data-bbox="516 1402 716 1486">P</td> <td data-bbox="716 1402 1003 1486">C1-POLID and C1-MPID</td> <td data-bbox="1003 1402 1468 1486">Paid through date is calculated at the policy level</td> </tr> <tr> <td data-bbox="516 1486 716 1570">M</td> <td data-bbox="716 1486 1003 1570">C1-POLID</td> <td data-bbox="1003 1486 1468 1570">Paid through date is not calculated at the membership level</td> </tr> <tr> <td data-bbox="516 1570 716 1654">M</td> <td data-bbox="716 1570 1003 1654">C1-MPID</td> <td data-bbox="1003 1570 1468 1654">Paid through date is calculated at the membership level</td> </tr> <tr> <td data-bbox="516 1654 716 1738">M</td> <td data-bbox="716 1654 1003 1738">C1-POLID and C1-MPID</td> <td data-bbox="1003 1654 1468 1738">Paid through date is calculated at the membership level</td> </tr> <tr> <td data-bbox="516 1738 716 1822">P, M</td> <td data-bbox="716 1738 1003 1822">C1-POLID</td> <td data-bbox="1003 1738 1468 1822">Paid through date is calculated at the policy level</td> </tr> <tr> <td data-bbox="516 1822 716 1906">P, M</td> <td data-bbox="716 1822 1003 1906">C1-MPID</td> <td data-bbox="1003 1822 1468 1906">Paid through date is calculated at both the policy and membership levels</td> </tr> <tr> <td data-bbox="516 1906 716 1976">P, M</td> <td data-bbox="716 1906 1003 1976">C1-POLID and C1-MPID</td> <td data-bbox="1003 1906 1468 1976">Paid through date is calculated at both the policy and membership levels</td> </tr> </tbody> </table>	Entity	System Event	Algorithm	Customer Class	Payment Freeze	C1-PSPTDCAL	Customer Class	Payment Cancellation	C1-PXPTDCAL	Adjustment Type	Adjustment Freeze	C1-ADPTDCAL	Adjustment Type	Adjustment Cancellation	C1-AXPTDCAL	If the Paid Through Date Calculation Level parameter is set to...	If the following characteristics are defined for the billable charge or adjustment...	Then...	P	C1-POLID	Paid through date is calculated at the policy level	P	C1-MPID	Paid through date is calculated at the policy level	P	C1-POLID and C1-MPID	Paid through date is calculated at the policy level	M	C1-POLID	Paid through date is not calculated at the membership level	M	C1-MPID	Paid through date is calculated at the membership level	M	C1-POLID and C1-MPID	Paid through date is calculated at the membership level	P, M	C1-POLID	Paid through date is calculated at the policy level	P, M	C1-MPID	Paid through date is calculated at both the policy and membership levels	P, M	C1-POLID and C1-MPID	Paid through date is calculated at both the policy and membership levels
Entity	System Event	Algorithm																																												
Customer Class	Payment Freeze	C1-PSPTDCAL																																												
Customer Class	Payment Cancellation	C1-PXPTDCAL																																												
Adjustment Type	Adjustment Freeze	C1-ADPTDCAL																																												
Adjustment Type	Adjustment Cancellation	C1-AXPTDCAL																																												
If the Paid Through Date Calculation Level parameter is set to...	If the following characteristics are defined for the billable charge or adjustment...	Then...																																												
P	C1-POLID	Paid through date is calculated at the policy level																																												
P	C1-MPID	Paid through date is calculated at the policy level																																												
P	C1-POLID and C1-MPID	Paid through date is calculated at the policy level																																												
M	C1-POLID	Paid through date is not calculated at the membership level																																												
M	C1-MPID	Paid through date is calculated at the membership level																																												
M	C1-POLID and C1-MPID	Paid through date is calculated at the membership level																																												
P, M	C1-POLID	Paid through date is calculated at the policy level																																												
P, M	C1-MPID	Paid through date is calculated at both the policy and membership levels																																												
P, M	C1-POLID and C1-MPID	Paid through date is calculated at both the policy and membership levels																																												

Field Name	Field Description
Runout End Date	Displays the date when the runout period of the self-funded policy ends.  <b>Note:</b> This field appears only when you are viewing the details of a policy which is created using a policy type where the policy category is set to <b>Self-Funded</b> .
Runout Administration Fees	Indicates whether the administration fees must be charged when the claim transaction for the self-funded policy is processed in the runout period. The valid values are: <ul style="list-style-type: none"> <li>• None</li> <li>• Percentage of Claim</li> </ul> <b>Note:</b> This field appears only when you are viewing the details of a policy which is created using a policy type where the policy category is set to <b>Self-Funded</b> .

- **Persons** - Lists the persons which are associated with the policy. It contains the following columns:

Column Name	Column Description
Person Information	Indicates the person who is associated with the policy. In addition, this column has a context menu which helps in navigating to other screens in the application.  <b>Note:</b> It has a link. On clicking the link, the <b>Person</b> screen appears where you can view the details of the respective person.
Sequence	Displays the sequence number of the associated person.
Policy Person Role	Indicates the role of the person in the policy.
Main Customer	Indicates whether the person is the main customer of the policy.
Start Date	Displays the date from when the person is associated with the policy.
End Date	Displays the date till when the person is associated with the policy.

- **Characteristics** - Lists the characteristics which are defined for the policy. It contains the following columns:

Column Name	Column Description
Effective Date	Displays the date from when the characteristic is effective for the policy.
Characteristic Type	Indicates the characteristic type.  <b>Note:</b> It has a link when you are viewing the details of a policy which is created using a policy type where the policy category is set to <b>Fully-Insured Group</b> or <b>Fully-Insured Individual</b> . On clicking the link, the <b>Characteristic Type</b> screen appears where you can view the details of the respective characteristic type.
Characteristic Value	Displays the value of the characteristic type.
Description	Displays the description of the characteristic value.  <b>Note:</b> This column appears when you are viewing the details of a policy which is created using a policy type where the policy category is set to <b>Fully-Insured Group</b> or <b>Fully-Insured Individual</b> .

- **Record Actions** - This section contains the following buttons:

Button Name	Button Description						
Edit	<p>Used to edit the details of the fully-insured or self-funded policy.</p> <p><b>Note:</b> The <b>Edit</b> button appears only when a policy of the respective category is in either of the following status:</p> <table border="1" data-bbox="521 401 1463 968"> <thead> <tr> <th data-bbox="521 401 907 449">Policy Category</th> <th data-bbox="907 401 1463 449">Status</th> </tr> </thead> <tbody> <tr> <td data-bbox="521 449 907 804">Fully-Insured Group or Fully-Insured Individual</td> <td data-bbox="907 449 1463 804"> <ul style="list-style-type: none"> <li>• In Force/Active</li> <li>• Canceled</li> <li>• Pending Cancellation</li> <li>• Pending</li> <li>• Pending Reinstatement</li> <li>• Pending Termination</li> <li>• Terminated</li> </ul> </td> </tr> <tr> <td data-bbox="521 804 907 968">Self-Funded</td> <td data-bbox="907 804 1463 968"> <ul style="list-style-type: none"> <li>• In Force/Active</li> <li>• Pending</li> <li>• Runout</li> </ul> </td> </tr> </tbody> </table>	Policy Category	Status	Fully-Insured Group or Fully-Insured Individual	<ul style="list-style-type: none"> <li>• In Force/Active</li> <li>• Canceled</li> <li>• Pending Cancellation</li> <li>• Pending</li> <li>• Pending Reinstatement</li> <li>• Pending Termination</li> <li>• Terminated</li> </ul>	Self-Funded	<ul style="list-style-type: none"> <li>• In Force/Active</li> <li>• Pending</li> <li>• Runout</li> </ul>
Policy Category	Status						
Fully-Insured Group or Fully-Insured Individual	<ul style="list-style-type: none"> <li>• In Force/Active</li> <li>• Canceled</li> <li>• Pending Cancellation</li> <li>• Pending</li> <li>• Pending Reinstatement</li> <li>• Pending Termination</li> <li>• Terminated</li> </ul>						
Self-Funded	<ul style="list-style-type: none"> <li>• In Force/Active</li> <li>• Pending</li> <li>• Runout</li> </ul>						
Delete	<p>Used to delete the fully-insured or self-funded policy.</p> <p><b>Note:</b> The <b>Delete</b> button appears only when a policy of the respective category is in either of the following status:</p> <table border="1" data-bbox="521 1213 1463 1682"> <thead> <tr> <th data-bbox="521 1213 932 1262">Policy Category</th> <th data-bbox="932 1213 1463 1262">Status</th> </tr> </thead> <tbody> <tr> <td data-bbox="521 1262 932 1617">Fully-Insured Group or Fully-Insured Individual</td> <td data-bbox="932 1262 1463 1617"> <ul style="list-style-type: none"> <li>• In Force/Active</li> <li>• Canceled</li> <li>• Pending Cancellation</li> <li>• Pending</li> <li>• Pending Reinstatement</li> <li>• Pending Termination</li> <li>• Terminated</li> </ul> </td> </tr> <tr> <td data-bbox="521 1617 932 1682">Self-Funded</td> <td data-bbox="932 1617 1463 1682"> <ul style="list-style-type: none"> <li>• Pending</li> </ul> </td> </tr> </tbody> </table> <p>You can delete a fully-insured policy until the plans are not defined for the policy.</p>	Policy Category	Status	Fully-Insured Group or Fully-Insured Individual	<ul style="list-style-type: none"> <li>• In Force/Active</li> <li>• Canceled</li> <li>• Pending Cancellation</li> <li>• Pending</li> <li>• Pending Reinstatement</li> <li>• Pending Termination</li> <li>• Terminated</li> </ul>	Self-Funded	<ul style="list-style-type: none"> <li>• Pending</li> </ul>
Policy Category	Status						
Fully-Insured Group or Fully-Insured Individual	<ul style="list-style-type: none"> <li>• In Force/Active</li> <li>• Canceled</li> <li>• Pending Cancellation</li> <li>• Pending</li> <li>• Pending Reinstatement</li> <li>• Pending Termination</li> <li>• Terminated</li> </ul>						
Self-Funded	<ul style="list-style-type: none"> <li>• Pending</li> </ul>						

Button Name	Button Description						
Activate	<p>Used to activate the fully-insured or self-funded policy.</p> <p><b>Note:</b> The <b>Activate</b> button appears only when a policy of the respective category is in either of the following status:</p> <table border="1" data-bbox="521 401 1459 632"> <thead> <tr> <th data-bbox="521 401 954 449">Policy Category</th> <th data-bbox="954 401 1459 449">Status</th> </tr> </thead> <tbody> <tr> <td data-bbox="521 449 954 562">Fully-Insured Group or Fully-Insured Individual</td> <td data-bbox="954 449 1459 562"> <ul style="list-style-type: none"> <li>• Pending</li> <li>• Pending Termination</li> </ul> </td> </tr> <tr> <td data-bbox="521 562 954 632">Self-Funded</td> <td data-bbox="954 562 1459 632"> <ul style="list-style-type: none"> <li>• Pending</li> </ul> </td> </tr> </tbody> </table>	Policy Category	Status	Fully-Insured Group or Fully-Insured Individual	<ul style="list-style-type: none"> <li>• Pending</li> <li>• Pending Termination</li> </ul>	Self-Funded	<ul style="list-style-type: none"> <li>• Pending</li> </ul>
Policy Category	Status						
Fully-Insured Group or Fully-Insured Individual	<ul style="list-style-type: none"> <li>• Pending</li> <li>• Pending Termination</li> </ul>						
Self-Funded	<ul style="list-style-type: none"> <li>• Pending</li> </ul>						
Initiate Cancellation	<p>Used to initiate the cancellation process for the fully-insured policy.</p> <p><b>Note:</b> The <b>Initiate Cancellation</b> button appears only when the fully-insured policy is in the <b>In Force/Active</b> status.</p>						
Cancel	<p>Used to cancel the fully-insured policy.</p> <p><b>Note:</b> The <b>Cancel</b> button appears only when the fully-insured policy is in the <b>Pending Cancellation</b> status.</p>						
Initiate Termination	<p>Used to initiate the termination process for the fully-insured policy.</p> <p><b>Note:</b> The <b>Initiate Termination</b> button appears only when the fully-insured policy is in the <b>In Force/Active</b> status.</p>						
Terminate	<p>Used to terminate the fully-insured policy.</p> <p><b>Note:</b> The <b>Terminate</b> button appears only when the fully-insured policy is in the <b>In Force/Active, Pending Reinstatement, or Pending Termination</b> status.</p>						
Initiate Reinstatement	<p>Used to initiate the reinstatement process for the terminated policy.</p> <p><b>Note:</b> The <b>Initiate Reinstatement</b> button appears only when the fully-insured policy is in the <b>Terminated</b> status.</p>						
Reinstate	<p>Used to reinstate the terminated policy.</p> <p><b>Note:</b> The <b>Reinstate</b> button appears only when the fully-insured policy is in the <b>Pending Reinstatement or Terminated</b> status.</p>						

Button Name	Button Description
Runout	Used to transition the self-funded policy to the <b>Runout</b> status.  <div style="border: 1px solid black; padding: 5px;"> <p><b>Note:</b></p> <p>The <b>Runout</b> button appears only when the self-funded policy is in the <b>In Force/Active</b> status.</p> <p>You cannot transition a self-funded policy to the <b>Runout</b> status when:</p> <ul style="list-style-type: none"> <li>• The self-funded policy is renewed.</li> <li>• The runout end date is not specified.</li> <li>• The policy end date is earlier than the system date.</li> </ul> </div>

- **Record Information** - This section contains the following fields:

Field Name	Field Description
Business Object	Indicates the business object using which the policy is created. In addition, a context menu appears corresponding to this field which helps in navigating to other screens in the application.  <div style="border: 1px solid black; padding: 5px;"> <p><b>Note:</b> It has a link. On clicking the link, the <b>Business Object</b> screen appears where you can view the details of the respective business object.</p> </div>
Status Date/Time	Displays the date and time when the policy status is updated.
Create Date/Time	Displays the date and time when the policy is created.

- **Termination Information** - Displays the termination details of the fully-insured policy. It appears only when the policy is in the **Pending Termination** status. It contains the following fields:

Field Name	Field Description
Terminate Date	Displays the date when you want to terminate the policy.
Terminate Reason	Indicates the reason why the termination process is initiated for the policy.  <div style="border: 1px solid black; padding: 5px;"> <p><b>Note:</b> It has a link. On clicking the link, the <b>Status Reason</b> screen appears where you can view the details of the respective termination reason.</p> </div>

- **Reinstate Information** - Displays the reinstatement details of the terminated policy. It appears only when the policy is in the **Pending Reinstatement** status. It contains the following fields:

Field Name	Field Description
Reinstate Reason	Indicates the reason why you want to reinstate the fully-insured policy.  <div style="border: 1px solid black; padding: 5px;"> <p><b>Note:</b> It has a link. On clicking the link, the <b>Status Reason</b> screen appears where you can view the details of the respective reinstatement reason.</p> </div>

### Related Topics

For more information on...	See...
How to edit a policy	<a href="#">Editing a Policy</a> on page 2105
How to delete a policy	<a href="#">Deleting a Policy</a> on page 2109

For more information on...	See...
How to activate a policy	<a href="#">Activating a Policy</a> on page 2105
How to initiate a cancellation request for a fully-insured policy	<a href="#">Initiating the Cancellation Process for a Fully-Insured Policy</a> on page 2110
How to cancel a fully-insured policy	<a href="#">Canceling a Fully-Insured Policy</a> on page 2110
How to initiate a termination request for a fully-insured policy	<a href="#">Initiating the Termination Process for a Fully-Insured Policy</a> on page 2111
How to terminate a fully-insured policy	<a href="#">Terminating a Fully-Insured Policy</a> on page 2112
How to initiate a reinstatement request for a fully-insured policy	<a href="#">Initiating the Reinstatement Process for a Fully-Insured Policy</a> on page 2112
How to reinstate a fully-insured policy	<a href="#">Reinstating a Fully-Insured Policy</a> on page 2113

## Policy - Plan

The **Plan** tab lists the plans defined for the policy and memberships defined for each policy plan. It contains the following zones:

- [Plans](#) on page 2102
- [Memberships](#) on page 2103

### Plans

The **Plans** zone lists the plans which are defined in the policy. It contains the following columns:

Column Name	Column Description
Plan Information	Displays information about the policy plan. In addition, a context menu appears corresponding to this column which helps in navigating to other screens in the application.  <b>Note:</b> It has a link. On clicking the link, the <b>Policy Plan</b> screen appears where you can view the details of the respective policy plan.
Price Item Information	Indicates the price item to which the policy plan is associated.  <b>Note:</b> It has a link. On clicking the link, the <b>Price Item</b> screen appears where you can view the details of the respective price item.
Plan Number	Displays the plan number.
Plan Name	Displays the description of the policy plan.
Start Date	Displays the date from when the policy plan is effective.
End Date	Displays the date till when the policy plan is effective.
Edit	On clicking the <b>Edit</b> (  ) icon, the <b>Plan</b> screen appears where you can edit the details of the policy plan.

**Note:** Pagination is used to display limited number of records in this zone. You can use the navigation links, such as **Previous** and **Next** to navigate between pages.

You can define a new policy plan by clicking the **Add** link in the upper-right corner of this zone. On clicking the **Broadcast**  icon corresponding to a policy plan, the **Memberships** zone appears.

**Note:** Ideally, you define plans in a policy which is created using a policy type where the policy category is set to **Fully-Insured Group** or **Fully-Insured Individual**.

You can filter the list using various search criteria (such as, **Price Item**, **Plan Number**, and **Effective From**) available in the **Filter** area. By default, the **Filter** area is hidden. You can view the **Filter** area by clicking the **Filters**  icon in the upper-right corner of this zone.

### Related Topics

For more information on...	See...
How to define a plan for a fully-insured policy	<a href="#">Defining a Plan for a Fully-Insured Policy</a>
How to edit a plan of a fully-insured policy	<a href="#">Editing a Plan of a Fully-Insured Policy</a> on page 2124
<b>Memberships</b> zone	<a href="#">Memberships</a> on page 2103
How to view the plans of a fully-insured policy	<a href="#">Viewing the Plans of a Fully-Insured Policy</a> on page 2117
How to view the memberships of a fully-insured policy plan	<a href="#">Viewing the Membership Details of a Fully-Insured Policy Plan</a> on page 2119

### Memberships

The **Memberships** zone lists the memberships which are defined in the policy plan. It contains the following columns:

Column Name	Column Description
Start Date	Displays the date from when the membership is effective.
End Date	Displays the date till when the membership is effective.
Membership Information	Displays information about the membership. <b>Note:</b> It has a link. On clicking the link, the <b>Membership</b> screen appears where you can view the details of the respective membership.
Enrolled Members	Displays the number of members who have enrolled in the policy plan.
Status	Indicates the status of the membership. The valid values are: <ul style="list-style-type: none"> <li>Active</li> <li>Inactive</li> </ul>
Last Billed Coverage	Indicates the last bill segment generated for the membership which is in the <b>Frozen</b> status. In addition, a context menu appears corresponding to this column which helps in navigating to other screens in application. <b>Note:</b> It has a link. On clicking the link, the <b>Bill Segment</b> screen appears where you can view the details of respective bill segment.

**Note:** Pagination is used to display limited number of records in this zone. You can use the navigation links, such as **Previous** and **Next** to navigate between pages.

You can define a new membership by clicking the **Add** link in the upper right corner of this zone.

By default, the **Memberships** zone does not appear in the **Plan** tab. It appears only when you click the **Broadcast**  icon corresponding to the policy plan in the **Plans** zone.

You can filter the list using various search criteria (such as, **External Membership ID**, **Effective From**, **Person Name**, **Effective Till**, and **Status**) available in the **Filter** area. By default, the **Filter** area is hidden. You can view the **Filter** area by clicking the **Filters**  icon in the upper right corner of this zone.

You can change the layout of this zone. For more information on how to change the layout, see [Changing the Layout](#) on page 2882

### **Related Topics**

<b>For more information on...</b>	<b>See...</b>
How to define a membership for a fully-insured policy plan	<a href="#">Defining a Membership for a Fully-Insured Policy Plan</a> on page 2134
<b>Plans</b> zone	<a href="#">Plans</a> on page 2102
How to view the memberships of a fully-insured policy plan	<a href="#">Viewing the Membership Details of a Fully-Insured Policy Plan</a> on page 2119

## **Policy - Log**

The **Log** tab contains the following zone:

- [Policy Log](#) on page 2104

### **Policy Log**

The **Policy Log** zone lists the complete trail of actions performed on the policy. It contains the following columns:

<b>Column Name</b>	<b>Column Description</b>
Creation Date Time	Displays the date and time when the action was performed on the policy.
Details	Displays the details about the action performed on the policy.
User	Indicates the user who has performed the action on the policy.
Log Type	Indicates the type of the log.
Related Object	Indicates the object or entity which is created when the action is performed on the policy. <b>Note:</b> It contains a link. On clicking the link, the screen appears where you can view the details of the respective related object.
Status Reason	Indicates the reason why the status of the policy is changed.

**Note:** You can manually add a log entry for the policy by clicking the **Add Log Entry** link in the upper right corner of the **Policy Log** zone.

### **Related Topics**

<b>For more information on...</b>	<b>See...</b>
How to view the log of a policy	<a href="#">Viewing the Log of a Policy</a> on page 2126



For more information on...	See...
How to add a log entry for a policy	<a href="#">Adding a Log Entry for a Policy</a> on page 2126

## Activating a Policy

### Procedure

To activate a policy:

1. Search for the policy in the **Policy** screen.
2. In the **Search Results** section, click the link in the **Policy Information** column corresponding to the policy that you want to activate.

The **Policy** screen appears.

3. Ensure that the **Main** tab is selected.
4. Click the **Activate** button in the **Policy** zone.

The status of the policy is changed to **In Force/Active**.

<b>Note:</b>	
The <b>Activate</b> button appears only when a policy of the respective category is in either of the following status:	
Policy Category	Status
Fully-Insured Group or Fully-Insured Individual	<ul style="list-style-type: none"> <li>• Pending</li> <li>• Pending Termination</li> </ul>
Self-Funded	<ul style="list-style-type: none"> <li>• Pending</li> </ul>

### Related Topics

For more information on...	See...
How to search for a policy	<a href="#">Searching for a Policy</a> on page 2088
<b>Policy</b> screen	<a href="#">Policy (Used for Viewing)</a> on page 2095
<b>Policy</b> zone	<a href="#">Policy</a> on page 2095

## Editing a Policy

### Prerequisites

To edit a policy, you should have:

- Values defined for the **C1-SourceSystemLookup** extendable lookup

**Note:** This prerequisite is applicable only when you want to define a fully-insured policy.

- Values defined for the **RUNOUT\_ADM\_OPT\_FLG** lookup field

**Note:** This prerequisite is applicable only when you want to define a self-funded policy.

### Procedure

To edit a policy:

1. Search for the policy in the **Policy** screen.
2. In the **Search Results** section, click the link in the **Policy Information** column corresponding to the policy whose details you want to edit.

The **Policy** screen appears.

3. Ensure that the **Main** tab is selected.
4. Click the **Edit** button in the **Policy** zone.

The **Policy** screen appears. It contains the following sections:

- **Main** - Used to specify the basic details about the policy.
- **Persons** - Used to associate persons with the policy.
- **Characteristics** - Used to define characteristics for the policy.

The **Main** section contains the following fields:

Field Name	Field Description	Mandatory (Yes or No)
Policy Information	Displays information about the policy.	Not applicable
Policy Type	Indicates the policy type using which the policy is defined.	Not applicable
Status	Indicates the status of the policy. The valid values are: <ul style="list-style-type: none"> <li>• Pending</li> <li>• In Force/Active</li> <li>• Runout</li> <li>• Post Runout</li> </ul> <div style="border: 1px solid black; padding: 2px; margin-top: 5px;"> <b>Note:</b> This field appears only when you are editing a policy which is created using a policy type where the policy category is set to <b>Self-Funded</b>. </div>	Not applicable
Policy Number	Used to specify the policy number.	Yes
Description	Used to specify the description for the policy.	Yes
Source System	Used to indicate the external system from where the policy is originated. <div style="border: 1px solid black; padding: 2px; margin-top: 5px;"> <b>Note:</b> This field appears only when you are editing a policy which is created using a policy type where the policy category is set to <b>Fully-Insured Group</b> or <b>Fully-Insured Individual</b>. </div>	Yes

Field Name	Field Description	Mandatory (Yes or No)
Start Date	<p>Used to specify the date from when the policy is effective.</p> <p><b>Note:</b></p> <p>The policy start date cannot be later than the policy end date.</p> <p>You cannot change the start date of a self-funded policy when it is in the <b>In Force/Active</b>, <b>Runout</b>, or <b>Post Runout</b> status.</p>	Yes
End Date	<p>Used to specify the date till when the policy is effective.</p> <p><b>Note:</b></p> <p>The policy end date cannot be earlier than the policy start date.</p> <p>You cannot change the end date when the self-funded policy is in the <b>Runout</b> status.</p> <p>You cannot set the end date of a self-funded policy to a date which is later than or equal to the start date of a pricing rule which is defined for the <b>Runout</b> status.</p> <p>You cannot change the end date when the policy is renewed.</p>	Yes
Runout End Date	<p>Used to specify the date when the runout period of the self-funded policy ends.</p> <p><b>Note:</b></p> <p>This field appears only when you are editing a policy which is created using a policy type where the policy category is set to <b>Self-Funded</b>.</p> <p>The runout end date cannot be earlier than or equal to the policy end date.</p> <p>The runout end date cannot be earlier than or equal to the system date when the policy is in the <b>Runout</b> status.</p> <p>You cannot remove the runout end date when the policy is in the <b>Runout</b> or <b>Post Runout</b> status.</p> <p>You cannot set the runout end date to a date which is later than or equal to the start date of a pricing rule which is defined for the <b>Post Runout</b> status.</p> <p>You cannot set the runout end date to a date which is earlier than the end date of a pricing rule which is defined for the <b>Runout</b> status.</p>	No

Field Name	Field Description	Mandatory (Yes or No)
Runout Administration Fees	<p>Used to indicate whether the administration fees must be charged when the claim transaction for the self-funded policy is processed in the runout period. The valid values are:</p> <ul style="list-style-type: none"> <li>• None</li> <li>• Percentage of Claim</li> </ul> <p><b>Note:</b></p> <p>At present, this field is used only for the informational purposes and is not considered during the billable charge creation for the claim transactions which are received in the runout period of the policy.</p> <p>This field appears only when you are editing a policy which is created using a policy type where the policy category is set to <b>Self-Funded</b>.</p>	No

<b>Note:</b>	
The <b>Edit</b> button appears only when a policy of the respective category is in either of the following status:	
Policy Category	Status
Fully-Insured Group or Fully-Insured Individual	<ul style="list-style-type: none"> <li>• In Force/Active</li> <li>• Canceled</li> <li>• Pending Cancellation</li> <li>• Pending</li> <li>• Pending Reinstatement</li> <li>• Pending Termination</li> <li>• Terminated</li> </ul>
Self-Funded	<ul style="list-style-type: none"> <li>• In Force/Active</li> <li>• Pending</li> <li>• Runout</li> </ul>

5. Modify the required details in the **Main** section.
6. Associate the persons with the policy, if required.

**Note:** While editing a policy, you must ensure that one person is associated as the main customer of the policy.

7. Define, edit, or remove characteristics from the policy, if required.
8. Click **Save**.

The changes made to the policy are saved.

### **Related Topics**

For more information on...	See...
How to search for a policy	<a href="#">Searching for a Policy</a> on page 2088
<b>Policy</b> screen	<a href="#">Policy (Used for Viewing)</a> on page 2095
<b>Policy</b> zone	<a href="#">Policy</a> on page 2095
How to associate a person with a policy	<a href="#">Associating a Person with a Policy</a> on page 2092
How to define a characteristic for a policy	<a href="#">Defining a Characteristic for a Policy</a> on page 2093

## Deleting a Policy

### Procedure

To delete a policy:

1. Search for the policy in the **Policy** screen.
2. In the **Search Results** section, click the link in the **Policy Information** column corresponding to the policy that you want to delete.

The **Policy** screen appears.

3. Ensure that the **Main** tab is selected.
4. Click the **Delete** button in the **Policy** zone.

A message appears confirming whether you want to delete the policy.

<b>Note:</b>	
The <b>Delete</b> button appears only when a policy of the respective category is in either of the following status:	
<b>Policy Category</b>	<b>Status</b>
Fully-Insured Group or Fully-Insured Individual	<ul style="list-style-type: none"> <li>• In Force/Active</li> <li>• Canceled</li> <li>• Pending Cancellation</li> <li>• Pending</li> <li>• Pending Reinstatement</li> <li>• Pending Termination</li> <li>• Terminated</li> </ul>
Self-Funded	<ul style="list-style-type: none"> <li>• Pending</li> </ul>
You can delete a fully-insured policy until the plans are not defined for the policy.	

5. Click **OK**.

The policy is deleted.

### Related Topics

For more information on...	See...
How to search for a policy	<a href="#">Searching for a Policy</a> on page 2088
<b>Policy</b> screen	<a href="#">Policy (Used for Viewing)</a> on page 2095
<b>Policy</b> zone	<a href="#">Policy</a> on page 2095

## Initiating the Cancellation Process for a Fully-Insured Policy

### Procedure

To initiate the cancellation process for a fully-insured policy:

1. Search for the fully-insured policy in the **Policy** screen.
2. In the **Search Results** section, click the link in the **Policy Information** column corresponding to the policy for which you want to initiate the cancellation process.

The **Policy** screen appears.

3. Ensure that the **Main** tab is selected.
4. Click the **Initiate Cancellation** button in the **Policy** zone.

The status of the policy is changed to **Pending Cancellation**.

**Note:** The **Initiate Cancellation** button appears only when the fully-insured policy is in the **In Force/Active** status.

### Related Topics

For more information on...	See...
How to search for a fully-insured policy	<a href="#">Searching for a Policy</a> on page 2088
<b>Policy</b> screen	<a href="#">Policy (Used for Viewing)</a> on page 2095
<b>Policy</b> zone	<a href="#">Policy</a> on page 2095

## Canceling a Fully-Insured Policy

### Procedure

To cancel a fully-insured policy:

1. Search for the fully-insured policy in the **Policy** screen.
2. In the **Search Results** section, click the link in the **Policy Information** column corresponding to the policy that you want to cancel.

The **Policy** screen appears.

3. Ensure that the **Main** tab is selected.
4. Click the **Cancel** button in the **Policy** zone.

The status of the policy is changed to **Canceled**.

**Note:** The **Cancel** button appears only when the fully-insured policy is in the **Pending Cancellation** status.

### Related Topics

For more information on...	See...
How to search a fully-insured policy	<a href="#">Searching for a Policy</a> on page 2088
Policy screen	<a href="#">Policy (Used for Viewing)</a> on page 2095
Policy zone	<a href="#">Policy</a> on page 2095

## Initiating the Termination Process for a Fully-Insured Policy

### Prerequisites

To initiate the termination process for a fully-insured policy, you should have:

- Reasons defined for the **Terminated** status of the **C1-POLICY** business object in the **Status Reason** screen

### Procedure

To initiate the termination process for a fully-insured policy:

- Search for the fully-insured policy in the **Policy** screen.
- In the **Search Results** section, click the link in the **Policy Information** column corresponding to the policy for which you want to initiate the termination process.

The **Policy** screen appears.

- Ensure that the **Main** tab is selected.
- Click the **Initiate Termination** button in the **Policy** zone.

The **Termination Information** window appears. It contains the following fields:

Field Name	Field Description	Mandatory (Yes or No)
Terminate Reason	Used to indicate the reason why you want to initiate the termination process for the fully-insured policy.	Yes
Terminate Date	Used to specify the date when you want to terminate the policy.  <b>Note:</b> The terminate date cannot be earlier than the policy start date or later than the policy end date.	Yes

**Note:** The **Initiate Termination** button appears only when the fully-insured policy is in the **In Force/Active** status.

- Enter the required details in the **Termination Information** window.
- Click **Save**.

The status of the fully-insured policy is changed to **Pending Termination**.

### Related Topics

For more information on...	See...
How to search for a fully-insured policy	<a href="#">Searching for a Policy</a> on page 2088
Policy screen	<a href="#">Policy (Used for Viewing)</a> on page 2095
Policy zone	<a href="#">Policy</a> on page 2095

## Terminating a Fully-Insured Policy

### Prerequisites

To terminate a fully-insured policy, you should have:

- Reasons defined for the **Terminated** status of the **C1-POLICY** business object in the **Status Reason** screen

### Procedure

To terminate a fully-insured policy:

- Search for the fully-insured policy in the **Policy** screen.
- In the **Search Results** section, click the link in the **Policy Information** column corresponding to the policy that you want to terminate.

The **Policy** screen appears.

- Ensure that the **Main** tab is selected.
- Click the **Terminate** button in the **Policy** zone.

The **Status Reason** window appears. It contains the following field:

Field Name	Field Description	Mandatory (Yes or No)
Status Reason	Used to indicate the reason why you want to terminate the fully-insured policy.	Yes

**Note:** The **Terminate** button appears only when the fully-insured policy is in the **In Force/Active**, **Pending Reinstatement**, or **Pending Termination** status.

- Select the terminate reason from the respective field.
- Click **Save**.

The status of the policy is changed to **Terminated**.

**Note:** You cannot terminate a fully-insured policy which is in the **Pending Termination** status when the terminate date is earlier than the system date.

### Related Topics

For more information on...	See...
How to search for a fully-insured policy	<a href="#">Searching for a Policy</a> on page 2088
<b>Policy</b> screen	<a href="#">Policy (Used for Viewing)</a> on page 2095
<b>Policy</b> zone	<a href="#">Policy</a> on page 2095

## Initiating the Reinstatement Process for a Fully-Insured Policy

### Prerequisites

To initiate the reinstatement process for a fully-insured policy, you should have:

- Reasons defined for the **Reinstated** status of the **C1-POLICY** business object in the **Status Reason** screen

### Procedure

To initiate the reinstatement process for a fully-insured policy:



1. Search for the fully-insured policy in the **Policy** screen.
2. In the **Search Results** section, click the link in the **Policy Information** column corresponding to the policy for which you want to initiate the reinstatement process.

The **Policy** screen appears.

3. Ensure that the **Main** tab is selected.
4. Click the **Initiate Reinstatement** button in the **Policy** zone.

The **Reinstatement Information** window appears. It contains the following field:

Field Name	Field Description	Mandatory (Yes or No)
Reinstatement Reason	Used to indicate the reason why you want to initiate the reinstatement process for the fully-insured policy.	Yes

**Note:** The **Initiate Reinstatement** button appears only when the fully-insured policy is in the **Terminated** status.

5. Select the reinstatement reason from the respective field.
6. Click **Save**.

The status of the fully-insured policy is changed to **Pending Reinstatement**.

#### Related Topics

For more information on...	See...
How to search for a fully-insured policy	<a href="#">Searching for a Policy</a> on page 2088
<b>Policy</b> screen	<a href="#">Policy (Used for Viewing)</a> on page 2095
<b>Policy</b> zone	<a href="#">Policy</a> on page 2095

## Reinstating a Fully-Insured Policy

### Prerequisites

To reinstate a fully-insured policy, you should have:

- Reasons defined for the **Reinstated** status of the **C1-POLICY** business object in the **Status Reason** screen

### Procedure

To reinstate a fully-insured policy:

1. Search for the fully-insured policy in the **Policy** screen.
2. In the **Search Results** section, click the link in the **Policy Information** column corresponding to the policy that you want to reinstate.

The **Policy** screen appears.

3. Ensure that the **Main** tab is selected.
4. Click the **Reinstatement** button in the **Policy** zone.

The **Status Reason** window appears. It contains the following field:

Field Name	Field Description	Mandatory (Yes or No)
Status Reason	Used to indicate the reason why you want to reinstate the fully-insured policy.	Yes

**Note:** The **Reinstate** button appears only when the fully-insured policy is in the **Pending Reinstatement** or **Terminated** status.

5. Select the reinstatement reason from the respective field.
6. Click **Save**.

The status of the policy is changed to **Reinstated**.

### **Related Topics**

<b>For more information on...</b>	<b>See...</b>
How to search for a fully-insured policy	<a href="#">Searching for a Policy</a> on page 2088
<b>Policy</b> screen	<a href="#">Policy (Used for Viewing)</a> on page 2095
<b>Policy</b> zone	<a href="#">Policy</a> on page 2095

## **Manually Changing the Status of a Self-Funded Policy to Runout**

### **Prerequisites**

To manually change the status of a self-funded policy to **Runout**, you should have:

- Runout end date specified in the self-funded policy.

### **Procedure**

To manually change the status of a self-funded policy to **Runout**:

1. Search for the self-funded policy in the **Policy** screen.
2. In the **Search Results** section, click the link in the **Policy Information** column corresponding to the self-funded policy whose status you want to change.

The **Policy** screen appears.

3. Ensure that the **Main** tab is selected.
4. Click the **Runout** button in the **Policy** zone.

The status of the self-funded policy is changed to **Runout**.

### **Note:**

The **Runout** button appears only when the self-funded policy is in the **In Force/Active** status.

You cannot transition a self-funded policy to the **Runout** status when:

- The self-funded policy is renewed.
- The runout end date is not specified.
- The policy end date is earlier than the system date.

### **Related Topics**

<b>For more information on...</b>	<b>See...</b>
How to search for a self-funded policy	<a href="#">Searching for a Policy</a> on page 2088

For more information on...	See...
Policy screen	<a href="#">Policy (Used for Viewing)</a> on page 2095
Policy zone	<a href="#">Policy</a> on page 2095

## Renewing a Self-Funded Policy of a Bill Group

Oracle Revenue Management and Billing enables you to renew a self-funded policy which is associated with a bill group. However, note that you can renew a self-funded policy only when it is in the **In Force/Active** status and is not yet renewed. For more information, see [Self-Funded Policy Renewal](#) on page 2041.

### Procedure

To renew a self-funded policy of a bill group:

1. Search for the bill group who is associated with the self-funded policy (which you want to renew) in the **Customer 360° View** screen.
2. In the **Search Results** section, click the **View** () icon corresponding to the bill group whose details you want to view.

The **Person** tab appears in the **Customer 360° Information** screen.

3. Click the **Pricing** tab.

The **Pricing** tab appears.

4. In the **Bill Group ASO Policy Information** zone, click the **Renew** () icon in the **Renew** column corresponding to the self-funded policy which you want to renew.

The **Policy** screen appears. It contains the following sections:

- **Main** - Used to specify basic details about the renewed policy.
- **Persons** - Used to associate or disassociate persons from the renewed policy.

**Note:** You cannot disassociate persons who are associated with the base policy using a policy person role which is specified in the **Bill Group Policy Person Role** or **Parent Customer Policy Person Role** option type of the **C1-ASOBLNG** feature configuration.

- **Characteristics** - Used to define characteristics for the renewed policy.

The **Main** section contains the following fields:

Field Name	Field Description	Mandatory (Yes or No)
Base Policy Information	Indicates the policy which you want to renew.	Not applicable
Policy Type	Indicates the policy type using which the base policy is created.	Not applicable
Policy Number	Used to specify the policy number of the renewed policy.	Yes
Description	Used to specify the description for the renewed policy.	Yes

Field Name	Field Description	Mandatory (Yes or No)
Start Date	<p>Used to specify the date from when the renewed policy is effective.</p> <div data-bbox="537 289 1182 632" style="border: 1px solid black; padding: 5px;"> <p><b>Note:</b></p> <p>By default, the start date is set to the base policy's end date plus one day. For example, if the base policy's end date is 12-31-2018, then by default, the renewed policy's start date is set to 01-01-2019.</p> <p>The start date cannot be later than the end date.</p> <p>The start date cannot be earlier than or equal to the base policy's end date.</p> </div>	Yes
End Date	<p>Used to specify the date till when the renewed policy is effective.</p> <div data-bbox="537 737 1182 789" style="border: 1px solid black; padding: 5px;"> <p><b>Note:</b> The end date cannot be earlier than the start date.</p> </div>	Yes
Runout End Date	<p>Used to specify the date when the runout period of the renewed policy ends.</p> <div data-bbox="537 898 1182 978" style="border: 1px solid black; padding: 5px;"> <p><b>Note:</b> The runout end date cannot be earlier than or equal to the renewed policy's end date.</p> </div>	No
Runout Administration Fees	<p>Used to indicate whether the administration fees must be charged when the claim transaction for the policy is processed in the runout period. The valid values are:</p> <ul style="list-style-type: none"> <li>• None</li> <li>• Percentage of Claim</li> </ul> <div data-bbox="537 1220 1182 1360" style="border: 1px solid black; padding: 5px;"> <p><b>Note:</b> At present, this field is used only for the informational purposes and is not considered during the billable charge creation for the claim transactions which are received in the runout period of the policy.</p> </div>	No

Field Name	Field Description	Mandatory (Yes or No)
Copy Pricing Rules	<p>Used to indicate whether you want to copy the pricing rules of the base policy to the renewed policy. If you select the <b>Copy Pricing Rules</b> option, the system copies the following pricing rules of the base policy:</p> <ul style="list-style-type: none"> <li>• Claim</li> <li>• Retention Type Claim Based</li> <li>• Retention Type Enrollment Based</li> <li>• Recurring Flat Fees</li> <li>• Ancillary</li> </ul> <p><b>Note:</b></p> <p>While copying a pricing rule, the start and end dates of the new pricing rule are set to the renewed policy's start and end dates, respectively.</p> <p>If there are multiple pricing rules which are created using the same pricing rule type and are effective for the different date range, the system copies only one pricing rule from the base policy with the latest date range.</p>	No

**Note:** The **Renew** icon appears only when the policy is in the **In Force/Active** status and it is not yet renewed.

5. Enter the required details in the **Main** section.
6. Associate or disassociate persons from the renewed policy, if required.
7. Define, edit, or remove characteristics from the renewed policy, if required.
8. Click **Save**.

The renewed policy is created in the **Pending** status. The renewal date is stamped corresponding to the base policy in the **Bill Group ASO Policy Information** zone.

### Related Topics

For more information on...	See...
How to search for a person	<a href="#">Searching for a Person</a> on page 185
<b>Customer 360° Information</b> screen	<a href="#">Customer 360° Information</a> on page 196
<b>Pricing</b> tab	<a href="#">Customer 360° Information - Pricing</a> on page 229
<b>Bill Group ASO Policy Information</b> zone	<a href="#">Bill Group ASO Policy Information</a> on page 236
How to associate a person with a policy	<a href="#">Associating a Person with a Policy</a> on page 2092
How to define a characteristic for a policy	<a href="#">Defining a Characteristic for a Policy</a> on page 2093
How to setup the <b>C1-ASOBLLNG</b> feature configuration	<a href="#">Setting the C1-ASOBLLNG Feature Configuration</a> on page 2889

## Viewing the Plans of a Fully-Insured Policy

### Procedure

To view the plans of a fully-insured policy:

1. Search for the fully-insured policy in the **Policy** screen.
2. In the **Search Results** section, click the link in the **Policy Information** column corresponding to the policy whose details you want to view.

The **Policy** screen appears.

3. Click the **Plan** tab.

The **Plan** tab appears.

4. View the plans of the fully-insured policy in the **Plans** zone.

#### Related Topics

For more information on...	See...
How to search for a fully-insured policy	<a href="#">Searching for a Policy</a> on page 2088
<b>Policy</b> screen	<a href="#">Policy (Used for Viewing)</a> on page 2095
<b>Plans</b> zone	<a href="#">Plans</a> on page 2102

## Viewing the Memberships of a Fully-Insured Policy Plan

#### Procedure

To view the memberships of a fully-insured policy plan:

1. Search for the fully-insured policy in the **Policy** screen.
2. In the **Search Results** section, click the link in the **Policy Information** column corresponding to the policy whose details you want to view.

The **Policy** screen appears.

3. Click the **Plan** tab.

The **Plan** tab appears.

4. In the **Plans** zone, click the **Broadcast**  icon corresponding to the policy plan whose memberships you want to view.

The **Memberships** zone appears.

5. View the memberships of the fully-insured policy plan in the **Memberships** zone.

#### Related Topics

For more information on...	See...
How to search for a fully-insured policy	<a href="#">Searching for a Policy</a> on page 2088
<b>Policy</b> screen	<a href="#">Policy (Used for Viewing)</a> on page 2095
<b>Plans</b> zone	<a href="#">Plans</a> on page 2102
<b>Memberships</b> zone	<a href="#">Memberships</a> on page 2103

## Viewing the Fully-Insured Policy Plan Details

#### Procedure

To view the details of a fully-insured policy plan:

1. Search for the fully-insured policy in the **Policy** screen.
2. In the **Search Results** section, click the link in the **Policy Information** column corresponding to the policy whose details you want to view.  
The **Policy** screen appears.
3. Click the **Plan** tab.  
The **Plan** tab appears.
4. In the **Plans** zone, click the link in the **Plan Information** column corresponding to the policy plan whose details you want to view.  
The **Policy Plan** screen appears.
5. View the details of the policy plan in the **Policy Plan** zone.

### Related Topics

For more information on...	See...
How to search for a fully-insured policy	<a href="#">Searching for a Policy</a> on page 2088
<b>Policy</b> screen	<a href="#">Policy (Used for Viewing)</a> on page 2095
<b>Plans</b> zone	<a href="#">Plans</a> on page 2102
<b>Policy Plan</b> screen	<a href="#">Policy Plan (Used for Viewing)</a> on page 2127
<b>Policy Plan</b> zone	<a href="#">Policy Plan</a> on page 2127
<b>Memberships</b> zone	<a href="#">Memberships</a> on page 2103

## Viewing the Membership Details of a Fully-Insured Policy Plan

### Procedure

To view the details of a membership in a fully-insured policy plan:

1. Search for the fully-insured policy in the **Policy** screen.
2. In the **Search Results** section, click the link in the **Policy Information** column corresponding to the policy whose details you want to view.  
The **Policy** screen appears.
3. Click the **Plan** tab.  
The **Plan** tab appears.
4. In the **Plans** zone, click the **Broadcast**  icon corresponding to the fully-insured policy plan whose memberships you want to view.  
The **Memberships** zone appears.
5. In the **Memberships** zone, click the link in the **Membership Information** column corresponding to the membership whose details you want to view.  
The **Membership** screen appears.
6. Ensure that the **Main** tab is selected.
7. View the details of the membership in the **Membership** zone.

### Related Topics

For more information on...	See...
How to search for a fully-insured policy	<a href="#">Searching for a Policy</a> on page 2088
<b>Policy</b> screen	<a href="#">Policy (Used for Viewing)</a> on page 2095
<b>Plans</b> zone	<a href="#">Plans</a> on page 2102
<b>Memberships</b> zone	<a href="#">Memberships</a> on page 2103
<b>Membership</b> screen	<a href="#">Membership (Used for Viewing)</a> on page 2138
<b>Membership</b> zone	<a href="#">Membership</a> on page 2139

## Defining a Plan for a Fully-Insured Policy

### Prerequisites

To define a plan for a fully-insured policy, you should have:

- Policy plan business objects defined in the application
- Price items defined in the application

### Procedure

To define a plan for a fully-insured policy:

1. Search for the fully-insured policy in the **Policy** screen.
2. In the **Search Results** section, click the link in the **Policy Information** column corresponding to the policy for which you want to define a plan.

The **Policy** screen appears.

3. Click the **Plan** tab.

The **Plan** tab appears.

4. Click the **Add** link in the upper right corner of the **Plans** zone.

The **Select Business Object** screen appears. It contains the following field:

Field Name	Field Description	Mandatory (Yes or No)
Policy Plan Business Object	Used to indicate the business object using which you want to create a plan for a fully-insured policy.	Yes

**Tip:** Alternatively, you can access this screen by clicking the **Add** link in the upper right corner of the **Policy Plan** zone in the **Policy Plan** screen.

**Note:** The **Select Business Object** screen appears only when there are multiple policy plan business objects defined in the application. If there is only one policy plan business object defined in the application, the **Plan** screen appears.

5. Select the required policy plan business object from the respective field.
6. Click **OK**.

The **Plan** screen appears. It contains the following sections:

- **Main** - Used to specify the basic details about the policy plan.
- **Pricing Rule Types** - Used to associate the pricing rule types with the policy plan.



- **Characteristics** - Used to define characteristics for the policy plan.

The **Main** section contains the following fields:

Field Name	Field Description	Mandatory (Yes or No)
Policy Information	Indicates the fully-insured policy for which you want to create the policy plan.	Not applicable
Price Item	Used to indicate the price item which you want to associate with the policy plan.  <b>Note:</b> The <b>Search</b> (🔍) icon appears corresponding to this field. On clicking the <b>Search</b> icon, the <b>Price Item Search</b> window appears.  On specifying the price item, the description of the price item appears corresponding to the <b>Price Item</b> field.	Yes (Conditional)  <b>Note:</b> You must either specify the price item or associate at least one pricing rule type with the policy plan.
Plan Number	Used to specify the plan number.	Yes
Plan Name	Used to specify the description for the policy plan.	No
Start Date	Used to specify the date from when the policy plan is effective.  <b>Note:</b> The policy plan start date cannot be earlier than the policy start date and later than the policy end date.  The policy plan start date cannot be later than the policy plan end date.	Yes
End Date	Used to specify the date till when the policy plan is effective.  <b>Note:</b> The policy plan end date cannot be earlier than the policy start date and later than the policy end date.  The policy plan end date cannot be earlier than the policy plan start date.	No

7. Enter the required details in the **Main** section.
8. Associate the pricing rule types with the policy plan, if required.

**Note:** You must associate at least one pricing rule type with the policy plan when the price item is not specified in the policy plan.

9. Define the characteristics for the policy plan, if required.
10. Click **Save**.

The plan is defined for the fully-insured policy.

### **Related Topics**

For more information on...	See...
How to search for a fully-insured policy	<a href="#">Searching for a Policy</a> on page 2088
Policy screen	<a href="#">Policy (Used for Viewing)</a> on page 2095
Plans zone	<a href="#">Plans</a> on page 2102
Policy Plan zone	<a href="#">Policy Plan</a> on page 2127
How to associate a pricing rule type with a fully-insured policy plan	<a href="#">Associating a Pricing Rule Type with a Fully-Insured Policy Plan</a> on page 2122
How to define a characteristic for a fully-insured policy plan	<a href="#">Defining a Characteristic for a Fully-Insured Policy Plan</a> on page 2123

## Associating a Pricing Rule Type with a Fully-Insured Policy Plan

You can define a pricing rule using a pricing rule type for a fully-insured policy plan only when the pricing rule type is associated with the fully-insured policy plan. You can associate a pricing rule type with a fully-insured policy plan either from the user interface or through a health care inbound message.

### Prerequisites

To associate a pricing rule type with a fully-insured policy plan, you should have:

- Pricing rule types defined in the application (where the pricing rule type category is set to **Age Based**, **Tier Based**, or **Pass-Through Billable Charge**)

### Procedure

To associate a pricing rule type with a fully-insured policy plan:

- Ensure that the **Pricing Rule Types** section is expanded when you are defining or editing a fully-insured policy plan.

The **Pricing Rule Types** section contains the following field in a grid:

Field Name	Field Description	Mandatory (Yes or No)
Pricing Rule Type	<p>Used to indicate the pricing rule type that you want to associate with the fully-insured policy plan.</p> <p><b>Note:</b></p> <p>The <b>Search</b>  icon appears corresponding to this field. On clicking the <b>Search</b> icon, the <b>Pricing Rule Type Search</b> window appears.</p> <p>On specifying the pricing rule type, the description of the pricing rule type appears corresponding to the <b>Pricing Rule Type</b> field.</p> <p>Here, you can only specify a pricing rule type where the pricing rule type category is set to <b>Age Based</b>, <b>Tier Based</b>, or <b>Pass-Through Billable Charge</b>.</p>	<p>Yes (Conditional)</p> <p><b>Note:</b> You must either specify the price item or associate at least one pricing rule type with the policy plan.</p>

- Enter the required details in the **Pricing Rule Types** section.
- If you want to associate more than one pricing rule type with the fully-insured policy plan, click the **Add**  icon and then repeat step 2.

**Note:** However, if you want to dissociate a pricing rule type from the fully-insured policy plan, click the **Delete** (🗑️) icon corresponding to the pricing rule type.

4. Click **Save**.

The pricing rule types are associated with the fully-insured policy plan.

**Related Topics**

For more information on...	See...
How to define a plan for a fully-insured policy	<a href="#">Defining a Plan for a Fully-Insured Policy</a>
How to edit a plan of a fully-insured policy	<a href="#">Editing a Plan of a Fully-Insured Policy</a> on page 2124

## Defining a Characteristic for a Fully-Insured Policy Plan

**Prerequisites**

To define a characteristic for a fully-insured policy plan, you should have:

- Characteristic types defined in the application (where the characteristic entity is set to **Policy Plan**).

**Procedure**

To define a characteristic for a fully-insured policy plan:

1. Ensure that the **Characteristics** section is expanded when you are defining or editing a fully-insured policy plan.

The **Characteristics** section contains the following fields in a grid:

Field Name	Field Description	Mandatory (Yes or No)
Effective Date	Used to specify the date from when the characteristic is effective for the fully-insured policy plan. <b>Note:</b> The effective date cannot be earlier than the policy plan start date and later than the policy plan end date.	Yes (Conditional) <b>Note:</b> This field is required when you are defining a characteristic for the fully-insured policy plan.
Characteristic Type	Used to indicate the characteristic type. <b>Note:</b> The list includes only those characteristic types where the characteristic entity is set to <b>Policy Plan</b> .	Yes (Conditional) <b>Note:</b> This field is required when you are defining a characteristic for the fully-insured policy plan.

Field Name	Field Description	Mandatory (Yes or No)
Characteristic Value	<p>Used to specify the value for the characteristic type.</p> <p><b>Note:</b> If you select a predefined characteristic type, the <b>Search</b> (🔍) icon appears corresponding to the <b>Characteristic Value</b> field. On clicking the <b>Search</b> icon, the <b>Predefined Characteristic Search</b> window appears.</p> <p>On specifying the value for a predefined characteristic type, the description of the characteristic value appears corresponding to the <b>Characteristic Value</b> field.</p>	<p>Yes (Conditional)</p> <p><b>Note:</b> This field is required when you are defining a characteristic for the fully-insured policy plan.</p>

- Enter the required details in the **Characteristics** section.
- If you want to define more than one characteristic for the fully-insured policy plan, click the **Add** (+) icon and then repeat step 2.

**Note:** However, if you want to remove a characteristic from the fully-insured policy plan, click the **Delete** (🗑️) icon corresponding to the characteristic.

- Click **Save**.

The characteristics are defined for the fully-insured policy plan.

### Related Topics

For more information on...	See...
How to define a plan for a fully-insured policy	<a href="#">Defining a Plan for a Fully-Insured Policy</a>
How to edit a plan of a fully-insured policy	<a href="#">Editing a Plan of a Fully-Insured Policy</a> on page 2124

## Editing a Plan of a Fully-Insured Policy

### Prerequisites

To edit a plan of a fully-insured policy, you should have:

- Price items defined in the application

### Procedure

To edit a plan of a fully-insured policy:

- Search for the fully-insured policy in the **Policy** screen.
- In the **Search Results** section, click the link in the **Policy Information** column corresponding to the policy whose details you want to edit.  
The **Policy** screen appears.
- Click the **Plan** tab.  
The **Plan** tab appears.
- In the **Plans** zone, click the **Edit** (✎) icon in the **Edit** column corresponding to the policy plan whose details you want to edit.

The **Plan** screen appears. It contains the following sections:

- **Main** - Used to specify the basic details about the policy plan.
- **Pricing Rule Types** - Used to associate the pricing rule types with the policy plan.
- **Characteristics** - Used to define characteristics for the policy plan.

The **Main** section contains the following fields:

Field Name	Field Description	Mandatory (Yes or No)
Plan Information	Displays information about the fully-insured policy plan.	Not applicable
Policy Information	Indicates the fully-insured policy for which the policy plan is created.	Not applicable
Price Item	Used to indicate the price item which you want to associate with the policy plan.  <b>Note:</b> The <b>Search</b>  icon appears corresponding to this field. On clicking the <b>Search</b> icon, the <b>Price Item Search</b> window appears.  On specifying the price item, the description of the price item appears corresponding to the <b>Price Item</b> field.	Yes (Conditional)  <b>Note:</b> You must either specify the price item or associate at least one pricing rule type with the policy plan.
Plan Number	Used to specify the plan number.	Yes
Plan Name	Used to specify the description for the policy plan.	No
Start Date	Used to specify the date from when the policy plan is effective.  <b>Note:</b> The policy plan start date cannot be earlier than the policy start date and later than the policy end date.  The policy plan start date cannot be later than the policy plan end date.	Yes
End Date	Used to specify the date till when the policy plan is effective.  <b>Note:</b> The policy plan end date cannot be earlier than the policy start date and later than the policy end date.  The policy plan end date cannot be earlier than the policy plan start date.	No

**Tip:** Alternatively, you can edit the details of a fully-insured policy plan by clicking the **Edit** button in the **Policy Plan** zone of the **Policy Plan** screen.

5. Modify the required details in the **Main** section.
6. Associate the pricing rule types with the policy plan, if required.

**Note:** You must associate at least one pricing rule type with the policy plan when the price item is not specified in the policy plan.

7. Define, edit, or remove characteristics from the policy plan, if required.
8. Click **Save**.

The changes made to the fully-insured policy plan are saved.

### **Related Topics**

<b>For more information on...</b>	<b>See...</b>
How to search for a fully-insured policy	<a href="#">Searching for a Policy</a> on page 2088
<b>Policy</b> screen	<a href="#">Policy (Used for Viewing)</a> on page 2095
<b>Plans</b> zone	<a href="#">Plans</a> on page 2102
<b>Policy Plan</b> screen	<a href="#">Policy Plan (Used for Viewing)</a> on page 2127
<b>Policy Plan</b> zone	<a href="#">Policy Plan</a> on page 2127
How to associate a pricing rule type with a fully-insured policy plan	<a href="#">Associating a Pricing Rule Type with a Fully-Insured Policy Plan</a> on page 2122
How to define a characteristic for a fully-insured policy plan	<a href="#">Defining a Characteristic for a Fully-Insured Policy Plan</a> on page 2123

## **Viewing the Log of a Policy**

### **Procedure**

To view the log of a policy:

1. Search for the policy in the **Policy** screen.
2. In the **Search Results** section, click the link in the **Policy Information** column corresponding to the policy whose details you want to view.

The **Policy** screen appears.

3. Click the **Log** tab.

The **Log** tab appears.

4. View the complete trail of actions performed on the policy in the **Policy Log** zone.

### **Related Topics**

<b>For more information on...</b>	<b>See...</b>
How to search for a policy	<a href="#">Searching for a Policy</a> on page 2088
<b>Policy</b> screen	<a href="#">Policy (Used for Viewing)</a> on page 2095
<b>Policy Log</b> zone	<a href="#">Policy Log</a> on page 2104
How to add a log entry for a policy	<a href="#">Adding a Log Entry for a Policy</a> on page 2126

## **Adding a Log Entry for a Policy**

### **Procedure**

To add a log entry for a policy:

1. Search for the policy in the **Policy** screen.
2. In the **Search Results** section, click the link in the **Policy Information** column corresponding to the policy for which you want to add a log entry.

The **Policy** screen appears.

3. Click the **Log** tab.

The **Log** tab appears.

4. Click the **Add Log Entry** link in the upper right corner of the **Policy Log** zone.

The **Add Policy Log** window appears. It contains the following fields:

Field Name	Field Description	Mandatory (Yes or No)
Policy Information	Displays information about the policy.	Not applicable
Log Details	Used to specify additional comments on the policy.	Yes

5. Enter the comments in the **Log Details** field.
6. Click **Save**.

The log entry is added in the **Policy Log** zone.

#### **Related Topics**

For more information on...	See...
How to search for a policy	<a href="#">Searching for a Policy</a> on page 2088
<b>Policy</b> screen	<a href="#">Policy (Used for Viewing)</a> on page 2095
<b>Policy Log</b> zone	<a href="#">Policy Log</a> on page 2104

## **Policy Plan (Used for Viewing)**

---

The **Policy Plan** screen allows you to:

- View the details of a fully-insured policy plan
- Add and edit a fully-insured policy plan
- Add a membership to a fully-insured policy plan

It contains the following zones:

- [Policy Plan](#) on page 2127
- [Memberships](#) on page 2129

### **Policy Plan**

The **Policy Plan** zone displays the details of the policy plan. It contains the following sections:

- **Main** - Displays the basic information about the policy plan. It contains the following fields:

Field Name	Field Description
Plan Information	Displays information about the policy plan.

Field Name	Field Description
Policy Information	Displays information about the policy. <b>Note:</b> It has a link. On clicking the link, the <b>Policy</b> screen appears where you can view the details of the respective policy.
Price Item	Indicates the price item to which the policy plan is associated. <b>Note:</b> It has a link. On clicking the link, the <b>Price Item</b> screen appears where you can view the details of the respective price item.
Plan Number	Displays the plan number.
Plan Name	Displays the description of the policy plan.
Start Date	Displays the date from when the policy plan is effective.
End Date	Displays the date till when the policy plan is effective.

- **Pricing Rule Types** - Lists the pricing rule types which are associated with the policy plan. It contains the following column:

Column Name	Column Description
Pricing Rule Type	Indicates the pricing rule type which is associated with the policy plan. <b>Note:</b> It has a link. On clicking the link, the <b>Pricing Rule Type</b> screen appears where you can view the details of the respective pricing rule type.

- **Characteristics** - Lists the characteristics defined for the policy plan. It contains the following columns:

Column Name	Column Description
Effective Date	Displays the date from when the characteristic is effective for the policy plan.
Characteristic Type	Indicates the characteristic type.
Characteristic Value	Displays the value of the characteristic type.

- **Record Actions** - This section contains the following buttons:

Button Name	Button Description
Edit	Used to edit the details of the policy plan.

- **Record Information** - This section contains the following field:

Field Name	Field Description
Business Object	Indicates the business object using which the policy plan is created. In addition, a context menu appears corresponding to this field which helps in navigating to other screens in the application. <b>Note:</b> It has a link. On clicking the link, the <b>Business Object</b> screen appears where you can view the details of the respective business object.

You can define a new policy plan by clicking the **Add** link in the upper right corner of this zone.

### **Related Topics**



For more information on...	See...
How to define a plan for a fully-insured policy	<a href="#">Defining a Plan for a Fully-Insured Policy</a>
How to edit a plan of a fully-insured policy	<a href="#">Editing a Plan of a Fully-Insured Policy</a> on page 2124

## Memberships

The **Memberships** zone lists the memberships which are defined in the policy plan. It contains the following columns:

Column Name	Column Description
Start Date	Displays the date from when the membership is effective.
End Date	Displays the date till when the membership is effective.
Membership Information	Displays information about the membership. <b>Note:</b> It has a link. On clicking the link, the <b>Membership</b> screen appears where you can view the details of the respective membership.
Enrolled Members	Displays the number of members who have enrolled in the policy plan.
Status	Indicates the status of the membership. The valid values are: <ul style="list-style-type: none"> <li>• Active</li> <li>• Inactive</li> <li>• Terminated</li> </ul>
Last Billed Coverage	Indicates the last bill segment generated for the membership which is in the <b>Frozen</b> status. In addition, a context menu appears corresponding to this column which helps in navigating to other screens in application. <b>Note:</b> It has a link. On clicking the link, the <b>Bill Segment</b> screen appears where you can view the details of respective bill segment.

**Note:** Pagination is used to display limited number of records in this zone. You can use the navigation links, such as **Previous** and **Next** to navigate between pages.

You can define a new membership by clicking the **Add** link in the upper right corner of this zone.

You can filter the list using various search criteria (such as, **External Membership ID**, **Effective From**, **Person Name**, **Effective Till**, and **Status**) available in the **Filter** area. By default, the **Filter** area is hidden. You can view the **Filter** area by clicking the **Filters** (  ) icon in the upper right corner of this zone.

You can change the layout of this zone. For more information on how to change the layout, see [Changing the Layout](#) on page 2882

### Related Topics

For more information on...	See...
How to define a membership in a fully-insured policy plan	<a href="#">Defining a Membership for a Fully-Insured Policy Plan</a> on page 2134

## Membership (Used for Searching)

The **Membership** screen allows you to search for a membership using various search criteria. It also allows you to define a membership. It contains the following zone:

- [Search Membership](#) on page 2130



Through this screen, you can navigate to the following screen:

- [Membership \(Used for Viewing\)](#) on page 2138

### Search Membership

The **Search Membership** zone allows you to search for a membership using various search criteria. It contains the following two sections:

- **Search Criteria** - The **Search Criteria** section contains the following fields:

Field Name	Field Description	Mandatory (Yes or No)
Search By	Used to indicate whether you want to search for a membership using the policy plan, membership, or person details. The valid values are: <ul style="list-style-type: none"> <li>• Policy Plan Details</li> <li>• Membership Details</li> <li>• Person Details</li> </ul> <div style="border: 1px solid black; padding: 5px; margin-top: 10px;"> <b>Note:</b> By default, <b>Policy Plan Details</b> option is selected.         </div>	Yes
Policy ID	Used to search memberships which belong to plans of a particular policy. <div style="border: 1px solid black; padding: 5px; margin-top: 10px;"> <b>Note:</b>            The <b>Search</b>  icon appears corresponding to this field. On clicking the <b>Search</b> icon, the <b>Policy Search</b> window appears.            This field appears only when the <b>Policy Plan Details</b> option is selected from the <b>Search By</b> list.         </div>	No
Price Item	Used to search memberships which belong to plans where a particular price item is associated. <div style="border: 1px solid black; padding: 5px; margin-top: 10px;"> <b>Note:</b>            The <b>Search</b>  icon appears corresponding to this field. On clicking the <b>Search</b> icon, the <b>Price Item Search</b> window appears.            This field appears only when the <b>Policy Plan Details</b> or <b>Membership Details</b> option is selected from the <b>Search By</b> list.         </div>	No

Field Name	Field Description	Mandatory (Yes or No)
Plan Number	Used to search memberships of a particular plan.  <b>Note:</b> This field appears only when the <b>Policy Plan Details</b> option is selected from the <b>Search By</b> list.	No
Start Date	Used to search memberships which are effective from a particular date.  <b>Note:</b> This field appears only when the <b>Membership Details</b> option is selected from the <b>Search By</b> list.	No
Status	Used to search memberships with a particular status. The valid values are: <ul style="list-style-type: none"> <li>• Active</li> <li>• Inactive</li> <li>• Terminated</li> </ul> <b>Note:</b> This field appears only when the <b>Membership Details</b> option is selected from the <b>Search By</b> list.	No
End Date	Used to search memberships which are effective till a particular date.  <b>Note:</b> This field appears only when the <b>Membership Details</b> option is selected from the <b>Search By</b> list.	No
Person Name	Used to search memberships in which a particular person is added.  <b>Note:</b> This field appears only when the <b>Person Details</b> option is selected from the <b>Search By</b> list.	No
Person Identifier Type	Used to indicate the person identifier type.  <b>Note:</b> This field appears only when the <b>Person Details</b> option is selected from the <b>Search By</b> list.	No
Person Identifier	Used to search memberships in which a particular person is added.  <b>Note:</b> This field appears only when the <b>Person Details</b> option is selected from the <b>Search By</b> list.	No

**Note:** You must specify at least one search criterion while searching for a membership.

- **Search Results** - On clicking the **Search** button, the search results appear based on the specified search criteria. The **Search Results** section contains the following columns:

Column Name	Column Description
Policy Information	<p>Indicates the policy of the plan to which the membership is added.</p> <p><b>Note:</b> It has a link. On clicking the link, the <b>Policy</b> screen appears where you can view the details of the respective policy.</p>
Membership Information	<p>Displays information about the membership.</p> <p><b>Note:</b> It has a link. On clicking the link, the <b>Membership Information</b> screen appears where you can view the details of the respective membership.</p>
Price Item Information	<p>Indicates the price item which is associated with the plan to which the membership is added.</p> <p><b>Note:</b> It has a link. On clicking the link, the <b>Price Item</b> screen appears where you can view the details of the respective price item.</p>
Start Date	Displays the date from when the membership is effective.
End Date	Displays the date till when the membership is effective.
Status	<p>Indicates the status of the membership. The valid values are:</p> <ul style="list-style-type: none"> <li>• Active</li> <li>• Inactive</li> <li>• Terminated</li> </ul>
Person Information	<p>Indicates the person who is added to the membership. In addition, this column has a context menu which helps in navigating to other screens in the application.</p> <p><b>Note:</b></p> <p>It has a link. On clicking the link, the <b>Person</b> screen appears where you can view the details of the respective person.</p> <p>This column appears only when the <b>Person Details</b> option is selected from the <b>Search By</b> list.</p>

Column Name	Column Description						
Main Subscriber	<p>This column displays different data depending on whether you search for a membership using the policy plan, membership, or person details. The following table describes this column:</p> <table border="1"> <thead> <tr> <th>If you search for a membership using...</th> <th>Then...</th> </tr> </thead> <tbody> <tr> <td>The <b>Policy Plan Details</b> or <b>Membership Details</b> option</td> <td> <p>The <b>Main Subscriber</b> column displays the information about the person who is the main subscriber of the membership. In addition, this column has a context menu which helps in navigating to other screens in the application.</p> <div style="border: 1px solid black; padding: 5px;"> <p><b>Note:</b> It has a link. On clicking the link, the <b>Person</b> screen appears where you can view the details of the respective person.</p> </div> </td> </tr> <tr> <td>The <b>Person Details</b> option</td> <td> <p>The <b>Main Subscriber</b> column indicates whether the person is the main subscriber of the membership. The valid values are:</p> <ul style="list-style-type: none"> <li>• Y</li> <li>• N</li> </ul> </td> </tr> </tbody> </table>	If you search for a membership using...	Then...	The <b>Policy Plan Details</b> or <b>Membership Details</b> option	<p>The <b>Main Subscriber</b> column displays the information about the person who is the main subscriber of the membership. In addition, this column has a context menu which helps in navigating to other screens in the application.</p> <div style="border: 1px solid black; padding: 5px;"> <p><b>Note:</b> It has a link. On clicking the link, the <b>Person</b> screen appears where you can view the details of the respective person.</p> </div>	The <b>Person Details</b> option	<p>The <b>Main Subscriber</b> column indicates whether the person is the main subscriber of the membership. The valid values are:</p> <ul style="list-style-type: none"> <li>• Y</li> <li>• N</li> </ul>
If you search for a membership using...	Then...						
The <b>Policy Plan Details</b> or <b>Membership Details</b> option	<p>The <b>Main Subscriber</b> column displays the information about the person who is the main subscriber of the membership. In addition, this column has a context menu which helps in navigating to other screens in the application.</p> <div style="border: 1px solid black; padding: 5px;"> <p><b>Note:</b> It has a link. On clicking the link, the <b>Person</b> screen appears where you can view the details of the respective person.</p> </div>						
The <b>Person Details</b> option	<p>The <b>Main Subscriber</b> column indicates whether the person is the main subscriber of the membership. The valid values are:</p> <ul style="list-style-type: none"> <li>• Y</li> <li>• N</li> </ul>						

**Note:**

Pagination is used to display limited number of records in the **Search Results** section. You can use the navigation links, such as **Previous** and **Next** to navigate between pages.

**Related Topics**

For more information on...	See...
How to search for a membership	<a href="#">Searching for a Membership</a> on page 2133
How to view the details of a membership	<a href="#">Viewing the Membership Details</a> on page 2134

**Searching for a Membership****Prerequisites**

To search for a membership, you should have:

- Price items and person identifier types defined in the application

**Procedure**

To search for a membership:

1. Click the **Menu** link in the **Application** toolbar.  
A list appears.
2. From the **Main** menu, select **Person Information** and then click **Membership**.  
A sub-menu appears.
3. Click the **Search** option from the **Membership** sub-menu

The **Membership** screen appears.

4. Enter the search criteria in the **Search Membership** zone.

**Note:** ORMB search engine supports wildcard search, where you can substitute the percentage (%) symbol as a stand in for any word or letter in a search criteria. You can use the ‘%’ wildcard character in all input fields except the date and ID fields. The ‘%’ wildcard character is suffixed automatically at the end of the partial search criteria. Therefore, you may or may not specify the wildcard character at the end of the partial search criteria. However, you have to prefix the wildcard character manually wherever required.

5. Click **Search**.

A list of memberships that meet the search criteria appears in the **Search Results** section.

#### **Related Topics**

<b>For more information on...</b>	<b>See...</b>
<b>Membership</b> screen	<a href="#">Membership (Used for Searching)</a> on page 2130
<b>Search Membership</b> zone	<a href="#">Search Membership</a> on page 2130

## **Viewing the Membership Details**

### **Procedure**

To view the details of a membership:

1. Search for the membership in the **Membership** screen.
2. In the **Search Results** section, click the link in the **Membership Information** column corresponding to the membership whose details you want to view.  
The **Membership** screen appears.
3. Ensure that the **Main** tab is selected.
4. View the details of the membership in the **Membership** zone.

### **Related Topics**

<b>For more information on...</b>	
How to search for a membership	<a href="#">Searching for a Membership</a> on page 2133
<b>Membership</b> screen	<a href="#">Membership (Used for Viewing)</a> on page 2138
<b>Membership</b> zone	<a href="#">Membership</a> on page 2139

## **Defining a Membership for a Fully-Insured Policy Plan**

### **Prerequisites**

To define a membership for a fully-insured policy plan, you should have:

- Plans defined in the policy
- Persons defined in the application
- Contract relationship types defined in the application

### **Procedure**

To define a membership for a fully-insured policy plan:

1. Do either of the following:

If you want to...	Then...
Define a membership for a fully-insured policy plan from the <b>Policy</b> screen	<ol style="list-style-type: none"> <li>1. Search for the fully-insured policy in the <b>Policy</b> screen.</li> <li>2. In the <b>Search Results</b> section, click the link in the <b>Policy Information</b> column corresponding to the policy whose details you want to edit. The <b>Policy</b> screen appears.</li> <li>3. Click the <b>Plan</b> tab. The <b>Plan</b> tab appears.</li> <li>4. In the <b>Plans</b> zone, click the <b>Broadcast</b>  icon corresponding to the policy plan for which you want to define a membership. The <b>Memberships</b> zone appears.</li> <li>5. Click the <b>Add</b> link in the upper right corner of the <b>Memberships</b> zone.</li> </ol>
Define a membership for a fully-insured policy plan from the <b>Membership</b> screen	<ol style="list-style-type: none"> <li>1. Click the <b>Menu</b> link in the <b>Application</b> toolbar. A list appears.</li> <li>2. From the <b>Main</b> menu, select <b>Person Information</b> and then click <b>Membership</b>. A sub menu appears.</li> <li>3. Click the <b>Add</b> option from the <b>Membership</b> sub-menu.</li> </ol>

The **Membership** screen appears. It contains the following sections:

- **Main** - Used to specify the basic details about the membership.
- **Characteristics** - Used to define characteristics for the membership.

The **Main** section contains the following fields:

Field Name	Field Description	Mandatory (Yes or No)
Plan	<p>Used to indicate the policy plan for which you want to define the membership.</p> <p><b>Note:</b></p> <p>The <b>Search</b>  icon appears corresponding to this field. On clicking the <b>Search</b> icon, the <b>Policy Plan Search</b> window appears.</p> <p>On specifying the policy plan, the description of the policy plan appears corresponding to the <b>Plan</b> field.</p> <p>If you navigate to the <b>Membership</b> screen from the <b>Policy</b> screen, the data automatically appears in this field. You can change the plan, if required.</p>	Yes

Field Name	Field Description	Mandatory (Yes or No)
Start Date	Used to specify the date from when the membership is effective for a fully-insured policy plan.  <b>Note:</b> The membership start date cannot be later than the membership end date. The membership start date cannot be earlier than the policy plan start date or later than policy plan end date.	Yes
End Date	Used to specify the date till when the membership is effective for a fully-insured policy plan.  <b>Note:</b> The membership end date cannot be earlier than the membership start date. The membership end date cannot be earlier than the policy plan start date or later than policy plan end date.	Yes
Main Subscriber	Used to indicate the person who is the main subscriber of the membership.  <b>Note:</b> The <b>Search</b>  icon appears corresponding to this field. On clicking the <b>Search</b> icon, the <b>Person Search</b> window appears. On specifying the person, the description of the person appears corresponding to the <b>Main Subscriber</b> field.	Yes
Relationship Type	Used to indicate how the main subscriber is related to the membership.	Yes
External Membership ID	Used to specify the external membership ID.  <b>Note:</b> Here, you need to specify a membership ID which is maintained in the external source system.	No

**Tip:** Alternatively, you can access this screen by clicking the **Add** button in the **Page Title** area of the **Membership** screen.

2. Enter the required details in the **Main** section.
3. Define characteristics for the membership, if required.
4. Click **Save**.

The membership is defined for the fully-insured policy plan. The status of the membership and the main subscriber is set to **Active**.

#### **Related Topics**



For more information on...	See...
How to search for a fully-insured policy	<a href="#">Searching for a Policy</a> on page 2088
Policy screen	<a href="#">Policy (Used for Viewing)</a> on page 2095
Plans zone	<a href="#">Plans</a> on page 2102
Memberships zone	<a href="#">Memberships</a> on page 2103
Membership screen	<a href="#">Membership (Used for Searching)</a> on page 2130
How to define a characteristic for a membership	<a href="#">Defining a Characteristic for a Membership</a> on page 2137

## Defining a Characteristic for a Membership

### Prerequisites

To define a characteristic for a membership, you should have:

- Characteristic types defined in the application (where the characteristic entity is set to **Membership**)

### Procedure

To define a characteristic for a membership:

1. Ensure that the **Characteristics** section is expanded when you are defining or editing a membership.

The **Characteristics** section contains the following fields in a grid:

Field Name	Field Description	Mandatory (Yes or No)
Effective Date	Used to specify the date from when the characteristic is effective for the membership.  <b>Note:</b> The effective date cannot be earlier than the membership start date and later than the membership end date.	Yes (Conditional)  <b>Note:</b> This field is required when you are defining a characteristic for the membership.
Characteristic Type	Used to indicate the characteristic type.  <b>Note:</b> The list includes only those characteristic types where the characteristic entity is set to <b>Membership</b>	Yes (Conditional)  <b>Note:</b> This field is required when you are defining a characteristic for the membership.
Characteristic Value	Used to specify the value for the characteristic type.  <b>Note:</b> If you select a predefined characteristic type, the <b>Search</b>  icon appears corresponding to the <b>Characteristic Value</b> field. On clicking the <b>Search</b> icon, the <b>Predefined Characteristic Search</b> window appears.  On specifying the value for a predefined characteristic type, the description of the characteristic value appears corresponding to the <b>Characteristic Value</b> field.	Yes (Conditional)  <b>Note:</b> This field is required when you are defining a characteristic for the membership.

2. Enter the required details in the **Characteristics** section.

3. If you want to define more than one characteristic for the membership, click the **Add** (+) icon and then repeat step 2.

**Note:** However, if you want to remove a characteristic from the membership, click the **Delete** (🗑️) icon corresponding to the characteristic.

4. Click **Save**.

The characteristics are defined for the membership.

#### **Related Topics**

<b>For more information on...</b>	<b>See...</b>
How to define a membership for a fully-insured policy plan	<a href="#">Defining a Membership for a Fully-Insured Policy Plan</a> on page 2134
How to edit a membership of a fully-insured policy plan	<a href="#">Editing a Membership of a Fully-Insured Policy Plan</a> on page 2149

## **Membership (Used for Viewing)**

---

The **Membership** screen allows you to:

- View the details of a membership
- Edit the details of a membership
- Inactivate a membership
- Inactivate a member person
- Add or remove a person from a membership
- View the other plans of the main subscriber
- Associate or disassociate a contract from a membership
- View the billable charges created for a membership
- View the bill segments generated for a membership billable charge
- View the timeline details of a membership billable charge
- Viewing the pricing calculation details of a timeline
- View the log of a membership
- Add a log entry for a membership

It consists of the following tabs:

- [Membership - Main](#) on page 2138
- [Membership - Contracts and Charges](#) on page 2143
- [Membership - Log](#) on page 2148

### **Membership - Main**

The **Main** tab displays information about the membership. It also lists the persons which are included in the membership and other plans (within or across policies) where the main subscriber is associated. It contains the following zones:

- [Membership](#) on page 2139

- [Member Persons](#) on page 2141
- [Other Plans of Main Subscriber](#) on page 2142

## Membership

The **Membership** zone displays the details of the membership. It contains the following sections:

- **Main** - Displays basic information about the membership. It contains the following fields:

Field Name	Field Description
Membership Information	Displays information about the membership.
Plan Information	Indicates the policy plan for which the membership is defined. <b>Note:</b> It has a link. On clicking the link, the <b>Policy Plan</b> screen appears where you can view the details of the respective policy plan.
Status	Indicates the status of the membership. The valid values are: <ul style="list-style-type: none"> <li>• Active</li> <li>• Inactive</li> <li>• Terminated</li> </ul>
Start Date	Displays the date from when the membership is effective.
End Date	Displays the date till when the membership is effective.
External Membership ID	Displays the corresponding membership ID which is maintained in the external source system.

Field Name	Field Description																																													
Paid Through Date	<p data-bbox="540 205 1464 268">Indicates the term end date of the last fully or partially paid term. The system considers the term to be fully paid when the threshold limit is met.</p> <p data-bbox="540 296 1464 457"><b>Note:</b> This field appears only when the paid through date is calculated at the membership level. The paid through date is calculated while freezing or canceling a payment or adjustment depending on whether the required algorithm is attached to the respective system event:</p> <table border="1" data-bbox="540 478 1464 730"> <thead> <tr> <th data-bbox="540 478 802 529">Entity</th> <th data-bbox="802 478 1170 529">System Event</th> <th data-bbox="1170 478 1464 529">Algorithm</th> </tr> </thead> <tbody> <tr> <td data-bbox="540 529 802 579">Customer Class</td> <td data-bbox="802 529 1170 579">Payment Freeze</td> <td data-bbox="1170 529 1464 579">C1-PSPTDCAL</td> </tr> <tr> <td data-bbox="540 579 802 630">Customer Class</td> <td data-bbox="802 579 1170 630">Payment Cancellation</td> <td data-bbox="1170 579 1464 630">C1-PXPTDCAL</td> </tr> <tr> <td data-bbox="540 630 802 680">Adjustment Type</td> <td data-bbox="802 630 1170 680">Adjustment Freeze</td> <td data-bbox="1170 630 1464 680">C1-ADPTDCAL</td> </tr> <tr> <td data-bbox="540 680 802 730">Adjustment Type</td> <td data-bbox="802 680 1170 730">Adjustment Cancellation</td> <td data-bbox="1170 680 1464 730">C1-AXPTDCAL</td> </tr> </tbody> </table> <p data-bbox="540 751 1464 814">The following table indicates when the paid through date is calculated at the policy and/or membership level:</p> <table border="1" data-bbox="540 835 1464 1850"> <thead> <tr> <th data-bbox="540 835 781 1010">If the Paid Through Date Calculation Level parameter is set to...</th> <th data-bbox="781 835 1110 1010">If the following characteristics are defined for the bill charge or adjustment...</th> <th data-bbox="1110 835 1464 1010">Then...</th> </tr> </thead> <tbody> <tr> <td data-bbox="540 1010 781 1094">P</td> <td data-bbox="781 1010 1110 1094">C1-POLID</td> <td data-bbox="1110 1010 1464 1094">Paid through date is calculated at the policy level</td> </tr> <tr> <td data-bbox="540 1094 781 1178">P</td> <td data-bbox="781 1094 1110 1178">C1-MPID</td> <td data-bbox="1110 1094 1464 1178">Paid through date is calculated at the policy level</td> </tr> <tr> <td data-bbox="540 1178 781 1262">P</td> <td data-bbox="781 1178 1110 1262">C1-POLID and C1-MPID</td> <td data-bbox="1110 1178 1464 1262">Paid through date is calculated at the policy level</td> </tr> <tr> <td data-bbox="540 1262 781 1367">M</td> <td data-bbox="781 1262 1110 1367">C1-POLID</td> <td data-bbox="1110 1262 1464 1367">Paid through date is not calculated at the membership level</td> </tr> <tr> <td data-bbox="540 1367 781 1451">M</td> <td data-bbox="781 1367 1110 1451">C1-MPID</td> <td data-bbox="1110 1367 1464 1451">Paid through date is calculated at the membership level</td> </tr> <tr> <td data-bbox="540 1451 781 1535">M</td> <td data-bbox="781 1451 1110 1535">C1-POLID and C1-MPID</td> <td data-bbox="1110 1451 1464 1535">Paid through date is calculated at the membership level</td> </tr> <tr> <td data-bbox="540 1535 781 1619">P, M</td> <td data-bbox="781 1535 1110 1619">C1-POLID</td> <td data-bbox="1110 1535 1464 1619">Paid through date is calculated at the policy level</td> </tr> <tr> <td data-bbox="540 1619 781 1724">P, M</td> <td data-bbox="781 1619 1110 1724">C1-MPID</td> <td data-bbox="1110 1619 1464 1724">Paid through date is calculated at both the policy and membership levels</td> </tr> <tr> <td data-bbox="540 1724 781 1850">P, M</td> <td data-bbox="781 1724 1110 1850">C1-POLID and C1-MPID</td> <td data-bbox="1110 1724 1464 1850">Paid through date is calculated at both the policy and membership levels</td> </tr> </tbody> </table>	Entity	System Event	Algorithm	Customer Class	Payment Freeze	C1-PSPTDCAL	Customer Class	Payment Cancellation	C1-PXPTDCAL	Adjustment Type	Adjustment Freeze	C1-ADPTDCAL	Adjustment Type	Adjustment Cancellation	C1-AXPTDCAL	If the Paid Through Date Calculation Level parameter is set to...	If the following characteristics are defined for the bill charge or adjustment...	Then...	P	C1-POLID	Paid through date is calculated at the policy level	P	C1-MPID	Paid through date is calculated at the policy level	P	C1-POLID and C1-MPID	Paid through date is calculated at the policy level	M	C1-POLID	Paid through date is not calculated at the membership level	M	C1-MPID	Paid through date is calculated at the membership level	M	C1-POLID and C1-MPID	Paid through date is calculated at the membership level	P, M	C1-POLID	Paid through date is calculated at the policy level	P, M	C1-MPID	Paid through date is calculated at both the policy and membership levels	P, M	C1-POLID and C1-MPID	Paid through date is calculated at both the policy and membership levels
Entity	System Event	Algorithm																																												
Customer Class	Payment Freeze	C1-PSPTDCAL																																												
Customer Class	Payment Cancellation	C1-PXPTDCAL																																												
Adjustment Type	Adjustment Freeze	C1-ADPTDCAL																																												
Adjustment Type	Adjustment Cancellation	C1-AXPTDCAL																																												
If the Paid Through Date Calculation Level parameter is set to...	If the following characteristics are defined for the bill charge or adjustment...	Then...																																												
P	C1-POLID	Paid through date is calculated at the policy level																																												
P	C1-MPID	Paid through date is calculated at the policy level																																												
P	C1-POLID and C1-MPID	Paid through date is calculated at the policy level																																												
M	C1-POLID	Paid through date is not calculated at the membership level																																												
M	C1-MPID	Paid through date is calculated at the membership level																																												
M	C1-POLID and C1-MPID	Paid through date is calculated at the membership level																																												
P, M	C1-POLID	Paid through date is calculated at the policy level																																												
P, M	C1-MPID	Paid through date is calculated at both the policy and membership levels																																												
P, M	C1-POLID and C1-MPID	Paid through date is calculated at both the policy and membership levels																																												

- **Characteristics** - Lists the characteristics which are defined for the membership. It contains the following columns:

Column Name	Column Description
Effective Date	Displays the date from when the characteristic is effective for the membership.
Characteristic Type	Indicates the characteristic type.
Characteristic Value	Displays the value of the characteristic type.

- **Record Actions** - This section contains the following buttons:

Button Name	Button Description
Edit	Used to edit the details of the membership.
Inactivate	Used to inactivate the membership.

- **Record Information** - This section contains the following fields:

Field Name	Field Description
Business Object	Indicates the business object using which the membership is created. In addition, this column has a context menu which helps in navigating to other screens in the application.  <b>Note:</b> It has a link. On clicking the link, the <b>Business Object</b> screen appears where you can view the details of the respective business object.
Status Date/Time	Displays the date and time when the membership status is updated
Create Date/Time	Displays the date and time when the membership is created.

### **Related Topics**

For more information on...	See...
How to edit a membership of a fully-insured policy plan	<a href="#">Editing a Membership of a Fully-Insured Policy Plan</a> on page 2149
How to inactivate a membership	<a href="#">Inactivating a Membership</a> on page 2153

### **Member Persons**

The **Member Persons** zone lists the persons who are added to the membership. It contains the following columns:

Column Name	Column Description
Start Date	Displays the date from when the person is added to the membership.
End Date	Displays the date till when the person is added to the membership.
Person Information	Indicates the person who is added to the membership. In addition, it has the context menu which helps in navigating to other screens in the application.  <b>Note:</b> It has a link. On clicking the link, the <b>Person</b> screen appears where you can view the details of the respective person.
Relationship Type	Indicates how the person is related to the main subscriber.

Column Name	Column Description
Main Subscriber	Indicates whether the person is the main subscriber of the membership. The valid values are: <ul style="list-style-type: none"> <li>• Yes</li> <li>• No</li> </ul>
Status	Indicates the status of the member person. The valid values are: <ul style="list-style-type: none"> <li>• Active</li> <li>• Inactive</li> </ul>
Member	Indicates whether the person is added as a member to the membership. The valid values are: <ul style="list-style-type: none"> <li>• Yes</li> <li>• No</li> </ul>
Delete	On clicking the <b>Delete</b> (🗑️) icon, you can remove the person from the membership. <div style="border: 1px solid black; padding: 2px; margin-top: 5px;"><b>Note:</b> You cannot remove the member person who is the main subscriber of the membership.</div>
Edit	On clicking the <b>Edit</b> (✎) icon, the <b>Add/Edit Member Person</b> screen appears where you can edit the membership details of the person.

**Note:**

By default, the member persons which are in the **Active** status are listed in the **Member Persons** zone.

You can add a person to the membership by clicking the **Add Person** link in the upper right corner of this zone.

You can filter the list using the **Status** field available in the **Filter** area. By default, the **Filter** area is hidden. You can view the **Filter** area by clicking the **Filters** (🔍) icon in the upper right corner of this zone.

You can change the layout of this zone. For more information on how to change the layout, see [Changing the Layout](#) on page 2882.

**Related Topics**

For more information on...	See...
How to add a person to a membership	<a href="#">Adding a Person to a Membership</a> on page 2150
How to edit the membership details of a person	<a href="#">Editing the Membership Details of a Person</a> on page 2155
How to remove a person from a membership	<a href="#">Removing a Person from a Membership</a> on page 2155
How to inactivate a member person of a membership	<a href="#">Inactivating a Member Person</a> on page 2154

**Other Plans of Main Subscriber**

The **Other Plans of Main Subscriber** zone lists the additional memberships of the main subscriber. These memberships may belong to different plans within or across the policies. It contains the following columns:

Column Name	Column Description
Start Date	Displays the date from when the main subscriber is added to the membership.
End Date	Displays the date till when the main subscriber is added to the membership.
Plan Number	Indicates the fully-insured policy plan for which the membership is created.
Price Item	Indicates the price item to which the policy plan is associated.
Membership Information	Displays information about the membership. <b>Note:</b> It has a link. On clicking the link, the <b>Membership</b> screen appears where you can view the details of the respective membership.
Last Billed Coverage	Indicates the last bill segment generated for the membership which is in the <b>Frozen</b> status. In addition, a context menu appears corresponding to this column which helps in navigating to other screens in application. <b>Note:</b> It has a link. On clicking the link, the <b>Bill Segment</b> screen appears where you can view the details of the respective bill segment.

## Membership - Contracts and Charges

The **Contracts and Charges** tab lists the following:

- Contracts associated with the membership
- Billable charges created for the membership
- Bill segments generated for each billable charge
- Timeline generated for each billable charge
- Premium calculated for each eligible member person when an age based pricing is used during the membership premium calculation
- Premium calculated for the membership when a tier based pricing is used during the membership premium calculation

It contains the following zones:

- [Membership Contracts](#) on page 2143
- [Billable Charges](#) on page 2144
- [Bill Segment Details](#) on page 2146
- [Billable Charge Timeline Details](#) on page 2147
- [Pricing Calculation Details](#) on page 2147

### Membership Contracts

The **Membership Contracts** zone lists the contracts which are associated with the membership. It contains the following columns:

Column Name	Column Description
Start Date	Displays the date from when the contract is associated with the membership.
End Date	Displays the date till when the contract is associated with the membership.

Column Name	Column Description
Bill To	Indicates the entity against whom the corresponding charges are billed. The valid values are: <ul style="list-style-type: none"> <li>Federal</li> <li>State</li> <li>Group</li> <li>Individual</li> </ul>
Contract ID	Displays the contract ID. <b>Note:</b> It has a link. On clicking the link, the <b>Contract</b> screen appears where you can view the details of the respective contract.
Account Information	Indicates the account for which the contract is created. In addition, this column has a context menu which helps in navigating to other screens in the application. <b>Note:</b> It has a link. On clicking the link, the <b>Account</b> screen appears where you can view the details of the respective account.
Delete	On clicking the <b>Delete</b> (🗑️) icon, you can disassociate the contract from the membership.
Edit	On clicking the <b>Edit</b> (✎) icon, the <b>Associate Contract with Membership</b> screen appears where you can edit the contract association details of the membership.

**Note:** Pagination is used to display limited number of records in this zone. You can use the navigation links, such as **Previous** and **Next** to navigate between pages.

You can associate a contract with the membership by clicking the **Add Contract** link in the upper-right corner of this zone.

You can filter the list using the **Bill To** field available in the **Filter** area. By default, the **Filter** area is hidden. You can view the **Filter** area by clicking the **Filters** (🔍) icon in the upper-right corner of this zone.

### Related Topics

For more information on...	See...
How to associate a contract with a membership	<a href="#">Associating a Contract with a Membership</a> on page 2157
How to edit the contract association details of a membership	<a href="#">Editing the Contract Association Details of a Membership</a> on page 2159
How to disassociate a contract from a membership	<a href="#">Disassociating a Contract from a Membership</a> on page 2159

### **Billable Charges**

The **Billable Charges** zone lists the one-time or recurring billable charges which are created for the membership. It contains the following columns:

Column Name	Column Description
Start Date	Displays the start date of the billable charge.



Column Name	Column Description
End Date	Displays the end date of the billable charge.
Bill Period	Indicates the intervals at which the recurring bill segments must be created for the billable charge.
Price Item Information	Indicates the price item for which the billable charge is created. <b>Note:</b> It has a link. On clicking the link, the <b>Price Item</b> screen appears where you can view the details of the respective price item.
Contract ID	Indicates the contract against which the billable charge is created. <b>Note:</b> It has a link. On clicking the link, the <b>Contract</b> screen appears where you can view the details of the respective contract.
Billable Charge Information	Displays information about the billable charge. <b>Note:</b> It has a link. On clicking the link, the <b>Billable Charge</b> screen appears where you can view the details of the respective billable charge.
Amount	Displays the billable charge amount.
Status	Indicates the status of the billable charge. The valid values are: <ul style="list-style-type: none"> <li>• Billable</li> <li>• Cancelled</li> </ul>
Last Billed Coverage	Indicates the last bill segment generated for the billable charge which is in the <b>Frozen</b> status. In addition, a context menu appears corresponding to this column which helps in navigating to other screens in application. <b>Note:</b> It has a link. On clicking the link, the <b>Bill Segment</b> screen appears where you can view the details of the respective bill segment.

**Note:** Pagination is used to display limited number of records in this zone. You can use the navigation links, such as **Previous** and **Next** to navigate between pages.

On clicking the **Broadcast**  icon corresponding to a billable charge, the **Bill Segment Details** and **Billable Charge Timeline Details** zones appear.

**Note:** On clicking the **Broadcast**  icon, the **Billable Charge Timeline Details** zone appears only when the timeline details are available for the respective billable charge.

You can filter the list using various search criteria (such as, **Price Item**, **Start Date**, **Contract ID**, **End Date** and **Status**) available in the **Filter** area. By default, the **Filter** area is hidden. You can view the **Filter** area by clicking the **Filters**  icon in the upper right corner of this zone.

### Related Topics

For more information on...	See...
How to view the billable charges created for a membership	<a href="#">Viewing the Billable Charges Created for a Membership</a> on page 2161
<b>Bill Segment Details</b> zone	<a href="#">Bill Segment Details</a> on page 2146

<b>For more information on...</b>	<b>See...</b>
<b>Billable Charge Timeline Details</b> zone	<a href="#">Billable Charge Timeline Details</a> on page 2147

### Bill Segment Details

The **Bill Segment Details** zone lists all bill segments which are generated for the billable charge. It contains the following columns:

Column Name	Column Description
Start Date	Displays the start date of the bill segment.
End Date	Displays the end date of the bill segment.
Bill Segment Details	Displays information about the bill segment. In addition, this column has a context menu which helps in navigating to other screens in the application.  <b>Note:</b> It has a link. On clicking the link, the <b>Billable Segment</b> screen appears where you can view the details of the respective bill segment.
Amount	Displays the bill segment amount.
Status	Indicates the status of the bill segment. The valid values are: <ul style="list-style-type: none"> <li>• Incomplete</li> <li>• Error</li> <li>• Freezable</li> <li>• Pending Cancel</li> <li>• Canceled</li> <li>• Frozen</li> </ul>
Bill Information	Indicates the bill in which the bill segment is created. In addition, this column has a context menu which helps in navigating to other screens in the application.  <b>Note:</b> It has a link. On clicking the link, the <b>Bill</b> screen appears where you can view the details of the respective bill.

**Note:** Pagination is used to display limited number of records in this zone. You can use the navigation links, such as **Previous** and **Next** to navigate between pages.

By default, the **Bill Segment Details** zone does not appear in the **Contracts and Charges** tab of the **Membership** screen. It appears only when you click the **Broadcast**  icon corresponding to a billable charge in the **Billable Charges** zone.

You can filter the list using various search criteria (such as, **Start Date**, **Status**, and **End Date**) available in the **Filter** area. By default, the **Filter** area is hidden. You can view the **Filter** area by clicking the **Filters**  icon in the upper right corner of this zone.

### Related Topics

<b>For more information on...</b>	<b>See...</b>
How to view the billable segments generated for a billable charge	<a href="#">Viewing the Bill Segments Generated for a Billable Charge</a> on page 2161
<b>Billable Charges</b> zone	<a href="#">Billable Charges</a> on page 2144

## Billable Charge Timeline Details

The **Billable Charge Timeline Details** zone lists the timelines which are derived during the membership premium calculation. It appears only when the timeline details are available for the billable charge. It contains the following columns:

Column Name	Column Description
Start Date	Displays the start date of the timeline.
End Date	Displays the end date of the timeline.
Amount	Displays the premium amount calculated for the timeline.
Pricing Rule Information	Indicates the pricing rule using which the premium amount is calculated. <b>Note:</b> It has a link. On clicking the link, the <b>Pricing Rule</b> screen appears where you can view the details of the respective pricing rule.
Pricing Rule Type	Indicates the pricing rule type using which the pricing rule is created. <b>Note:</b> It has a link. On clicking the link, the <b>Pricing Rule Type</b> screen appears where you can view the details of the respective pricing rule type.

**Note:** Pagination is used to display limited number of records in this zone. You can use the navigation links, such as **Previous** and **Next** to navigate between pages.

By default, the **Billable Charge Timeline Details** zone does not appear in the **Contracts and Charges** tab of the **Membership** screen. It appears only when you click the **Broadcast**  icon corresponding to a billable charge in the **Billable Charges** zone.

On clicking the **Broadcast**  icon corresponding to a timeline, the **Pricing Calculation Details** zone appears.

You can filter the list using various search criteria (such as, **Start Date** and **End Date**) available in the **Filter** area.

By default, the **Filter** area is hidden. You can view the **Filter** area by clicking the **Filters**  icon in the upper right corner of this zone.

### Related Topics

For more information on...	See...
How to view the timeline details of a membership billable charge	<a href="#">Viewing the Timeline Details of a Membership Billable Charge</a> on page 2162
<b>Billable Charges</b> zone	<a href="#">Billable Charges</a> on page 2144
<b>Pricing Calculation Details</b> zone	<a href="#">Pricing Calculation Details</a> on page 2147
How the timeline is derived during the membership premium calculation	<a href="#">Membership Premium Calculation</a> on page 2841

### Pricing Calculation Details

The **Pricing Calculation Details** zone indicates how the amount is calculated for the timeline. If the age based pricing is used during the membership premium calculation, this zone lists the premium calculated for each eligible member of the membership. It also displays the base fee and modifier fee which are applicable for each eligible member. However, if the tier based pricing is used during the membership premium calculation, this zone lists the premium calculated at the membership level. It contains the following columns:

Column Name	Column Description
Entity Information	If the age based pricing is used during the membership premium calculation, this column indicates the eligible member for whom the premium amount is calculated. However, if the tier based pricing is used during the membership premium calculation, this column indicates the main subscriber of the membership.
Description on Bill	Displays the description of the rate component for which the price component is created in the age based or tier based pricing.
Pricing Parameter	Indicates the pricing eligibility criteria which is satisfied while deriving the base fee.
Amount	Displays the base fee or applicable modifier fee.
Total Amount	If the age based pricing is used during the membership premium calculation, this column displays the sum total of the base fee and modifier fee (if any) for the eligible member. However, if the tier based pricing is used during the membership premium calculation, this column displays the base fee applicable for the membership.

By default, the **Pricing Calculation Details** zone does not appear in the **Contracts and Charges** tab of the **Membership** screen. It appears only when you click the **Broadcast**  icon corresponding to a timeline in the **Billable Charge Timeline Details** zone.

#### **Related Topics**

For more information on...	See...
How to view the pricing calculation details of a timeline	<a href="#">Viewing the Pricing Calculation Details of a Timeline</a> on page 2162

## **Membership - Log**

The **Log** tab contains the following zone:

- [Membership Log](#) on page 2148

### **Membership Log**

The **Membership Log** zone lists the complete trail of actions performed on the membership. It contains the following columns:

Column Name	Column Description
Creation Date Time	Displays the date and time when the action was performed on the membership.
Details	Displays the details about the action performed on the membership.
User	Indicates the user who has performed the action on the membership.
Log Type	Indicates the type of log.
Related Object	Indicates the object or entity which is generated when the action is performed on the membership.  <b>Note:</b> It contains a link. On clicking the link, the screen appears where you can view the details of the respective related object.

Column Name	Column Description
Status Reason	Indicates the reason why the status of the membership is changed.  <b>Note:</b> At present, no data appears in this column. The implementation team can build the custom logic to meet the business requirements.

**Note:** You can manually add a log entry for the membership by clicking the **Add Log Entry** link in the upper right corner of the **Membership Log** zone.

### **Related Topics**

For more information on...	See...
How to view the log of a membership	<a href="#">Viewing the Log of a Membership</a> on page 2163
How to add a log entry for a membership	<a href="#">Adding a Log Entry for a Membership</a> on page 2163

## **Editing a Membership of a Fully-Insured Policy Plan**

### **Procedure**

To edit a membership of a fully-insured policy plan:

1. Search for the membership in the **Membership** screen.
2. In the **Search Results** section, click the link in the **Membership Information** column corresponding to the membership whose details you want to edit.

The **Membership** screen appears.

3. Ensure that the **Main** tab is selected.
4. Click the **Edit** button in the **Membership** zone.

The **Membership** screen appears. It contains the following sections:

- **Main** - Used to specify the basic details about the membership.
- **Characteristics** - Used to define characteristics for the membership.

The **Main** section contains the following fields:

Field Name	Field Description	Mandatory (Yes or No)
Membership Information	Displays information about the membership.	Not applicable
Plan Information	Indicates the policy plan for which the membership is defined.	Not applicable

Field Name	Field Description	Mandatory (Yes or No)
Start Date	Used to specify the date from when the membership is effective for a fully-insured policy plan.  <b>Note:</b> The membership start date cannot be later than the membership end date. The membership start date cannot be earlier than the policy plan start date or later than policy plan end date.	Yes
End Date	Used to specify the date till when the membership is effective for a fully-insured policy plan.  <b>Note:</b> The membership end date cannot be earlier than the membership start date. The membership end date cannot be earlier than the policy plan start date or later than policy plan end date.	Yes
External Membership ID	Used to specify the external membership ID.  <b>Note:</b> Here, you need to specify a membership ID which is maintained in the external source system.	No

5. Modify the required details in the **Main** section.
6. Define, edit, or remove characteristics from the membership, if required.
7. Click **Save**.

The changes made to the membership are saved.

### **Related Topics**

For more information on...	See...
How to search for a membership	<a href="#">Searching for a Membership</a> on page 2133
<b>Membership</b> screen	<a href="#">Membership (Used for Viewing)</a> on page 2138
<b>Membership</b> zone	<a href="#">Membership</a> on page 2139
How to define a characteristic for a membership	<a href="#">Defining a Characteristic for a Membership</a> on page 2137

## **Adding a Person to a Membership**

The system enables you to add a member person to a membership when the membership is in the **Active** status. However, you can only add a member person in the **Active** status and not in the **Inactive** status.

### **Prerequisites**

To add a person to a membership, you should have:

- Required persons defined in the application

- Contract relationship types defined in the application

### **Procedure**

To add a person to a membership:

1. Search for the membership in the **Membership** screen.
2. In the **Search Results** section, click the link in the **Membership Information** column corresponding to the membership to which you want to add a person.

The **Membership** screen appears.

3. Ensure that the **Main** tab is selected.
4. Click the **Add Person** link in the upper right corner of the **Member Persons** zone.

The **Add/Edit Member Person** screen appears. It contains the following sections:

- **Main** - Used to specify the basic membership details of the person.
- **Characteristics** - Used to define characteristics for the member person.

The **Main** section contains the following fields:

<b>Field Name</b>	<b>Field Description</b>	<b>Mandatory (Yes or No)</b>
Membership Information	Indicates the membership to which you want to add a person.	Not applicable
Person ID	Used to indicate the person whom you want to add to the membership.  <b>Note:</b> The <b>Search</b>  icon appears corresponding to this field. On clicking the <b>Search</b> icon, the <b>Person Search</b> window appears.	Yes
Relationship Type	Used to indicate how the person is related to the main subscriber.	Yes
Financially Responsible	Used to indicate whether the person is financially responsible for the membership.	No
Main Subscriber	Used to indicate whether the person is the main subscriber of the membership.	No
Member	Used to indicate whether the person is added as a member to the membership.	No
Start Date	Used to specify the date from when you want to add the person to the membership.  <b>Note:</b> The member person start date cannot be later than the member person end date. The member person start date cannot be earlier than the membership start date or later than the membership end date.	Yes

Field Name	Field Description	Mandatory (Yes or No)
End Date	Used to specify the date till when you want to add the person to the membership.  <b>Note:</b> The member person end date cannot be earlier than the member person start date. The member person end date cannot be earlier than the membership start date or later than the membership end date.	No
Membership Person Status	Used to indicate the status of the member person. The valid values are: <ul style="list-style-type: none"><li>Active</li><li>Inactive</li></ul> <b>Note:</b> By default, the <b>Active</b> option is selected.	Yes

- Enter the required details in the **Main** section.
- Define the characteristics for the member person, if required.
- Click **Save**.

The person is added to the membership.

#### Related Topics

For more information on...	See...
How to search for a membership	<a href="#">Searching for a Membership</a> on page 2133
<b>Membership</b> screen	<a href="#">Membership (Used for Viewing)</a> on page 2138
<b>Member Persons</b> zone	<a href="#">Member Persons</a> on page 2141
How to define a characteristic for a member person	<a href="#">Defining a Characteristic for a Member Person</a> on page 2152

## Defining a Characteristic for a Member Person

### Prerequisites

To define a characteristic for a member person, you should have:

- Characteristic types defined in the application (where the characteristic entity is set to **Membership Person**)

### Procedure

To define a characteristic for a member person:

- Ensure that the **Characteristics** section is expanded when you are adding a person to a membership or editing the membership details of a person.

The **Characteristics** section contains the following fields in a grid:



Field Name	Field Description	Mandatory (Yes or No)
Effective Date	Used to indicate the date from when the characteristic is effective for the member person.	Yes (Conditional) <b>Note:</b> This field is required when you are defining a characteristic for the member person.
Characteristic Type	Used to indicate the characteristic type. <b>Note:</b> The list includes only those characteristic types where the characteristic entity is set to <b>Membership Person</b> .	Yes (Conditional) <b>Note:</b> This field is required when you are defining a characteristic for the member person.
Characteristic Value	Used to specify the value for the characteristic type. <b>Note:</b> If you select a predefined characteristic type, the <b>Search</b> (🔍) icon appears corresponding to the <b>Characteristic Value</b> field. On clicking the <b>Search</b> icon, the <b>Predefined Characteristic Search</b> window appears. On specifying the value for a predefined characteristic type, the description of the characteristic value appears corresponding to the <b>Characteristic Value</b> field.	Yes (Conditional) <b>Note:</b> This field is required when you are defining a characteristic for the member person.

- Enter the required details in the **Characteristics** section.
- If you want to define more than one characteristic for the member person, click the **Add** (+) icon and then repeat step 2.

**Note:** However, if you want to remove a characteristic from the member person, click the **Delete** (🗑️) icon corresponding to the characteristic.

- Click **Save**.

The characteristics are defined for the member person.

### Related Topics

For more information on...	See...
How to add a person to a membership	<a href="#">Adding a Person to a Membership</a> on page 2150
How to edit the membership details of a person	<a href="#">Editing the Membership Details of a Person</a> on page 2155

## Inactivating a Membership

There are two ways in which you can inactivate the membership from the user interface:

- On clicking the **Inactivate** button
- On inactivating the main subscriber of the membership

**Procedure**

To inactivate a membership:

1. Search for the membership in the **Membership** screen.
2. In the **Search Results** section, click the link in the **Membership Information** column corresponding to the membership that you want to inactivate.

The **Membership** screen appears.

3. Ensure that the **Main** tab is selected.
4. Click the **Inactivate** button in the **Membership** zone.

The status of the membership is changed to **Inactive**.

**Related Topics**

For more information on...	See...
How to search for a membership	<a href="#">Searching for a Membership</a> on page 2133
<b>Membership</b> screen	<a href="#">Membership (Used for Viewing)</a> on page 2138
<b>Membership</b> zone	<a href="#">Membership</a> on page 2139

**Inactivating a Member Person**

The system enables you to inactivate a member person of a membership. If the member person is the main subscriber, the system automatically inactivates the membership and all other member persons which are included in the membership. It also does the following:

- Cancels the billable charges which are created for the membership
- Cancels the corresponding bill segments (if any)

If an audit event exists for the membership which is inactivated, the **BO\_STATUS\_CD** column corresponding to the record in the **C1\_AUDIT\_EVENT**, **C1\_AUDIT\_EVENT\_LOG**, and **CI\_PRCE\_CALC** tables is set to **INVALID**. If a repricing entity detail record exists for the membership in the **PENDING** or **ERROR** status, then the **BO\_STATUS\_CD** column corresponding to the record in the **CI\_REPRC\_ENTITY\_DTL** table is set to **COMPLETE**. If a repricing request exists for the membership in the **PENDING** or **ERROR** status, then the **BO\_STATUS\_CD** column corresponding to the record in the **CI\_REPRC\_REQ\_DTL** table is set to **COMPLETE**.

**Procedure**

To inactivate a member person of a membership:

1. Search for the membership in the **Membership** screen.
2. In the **Search Results** section, click the link in the **Membership Information** column corresponding to the membership whose details you want to edit.

The **Membership** screen appears.

3. Ensure that the **Main** tab is selected.
4. In the **Member Persons** zone, click the **Edit** (✎) icon in the **Edit** column corresponding to the member person whom you want to inactivate.

The **Add/Edit Member Person** screen appears.

5. Select the **Inactive** option from the **Membership Person Status** list.

The status of the member person is changed to **Inactive**.

**Related Topics**

For more information on...	See...
How to search for a membership	<a href="#">Searching for a Membership</a> on page 2133
<b>Membership</b> screen	<a href="#">Membership (Used for Viewing)</a> on page 2138
<b>Member Persons</b> zone	<a href="#">Member Persons</a> on page 2141

## Removing a Person from a Membership

### Procedure

To remove a person from a membership:

1. Search for the membership in the **Membership** screen.
2. In the **Search Results** section, click the link in the **Membership Information** column corresponding to the membership from which you want to remove a person.

The **Membership** screen appears.

3. Ensure that the **Main** tab is selected.
4. In the **Member Persons** zone, click the **Delete** () icon in the **Delete** column corresponding to the person that you want to remove from the membership.

A message appears confirming whether you want to remove the person from the membership.

**Note:** You cannot remove the member person who is the main subscriber of the membership.

5. Click **OK**.

The person is removed from the membership.

### Related Topics

For more information on...	See...
How to search for a membership	<a href="#">Searching for a Membership</a> on page 2133
<b>Membership</b> screen	<a href="#">Membership (Used for Viewing)</a> on page 2138
<b>Member Persons</b> zone	<a href="#">Member Persons</a> on page 2141

## Editing the Membership Details of a Person

### Prerequisites

To edit the membership details of a person, you should have:

- Contract relationship types defined in the application

### Procedure

To edit the membership details of a person:

1. Search for the membership in the **Membership** screen.
2. In the **Search Results** section, click the link in the **Membership Information** column corresponding to the membership whose details you want to edit.

The **Membership** screen appears.

3. Ensure that the **Main** tab is selected.
4. In the **Member Persons** zone, click the **Edit** () icon in the **Edit** column corresponding to the member person whose details you want to edit.

The **Add/Edit Member Person** screen appears. It contains the following sections:

- **Main** - Used to specify the basic membership details of the person.
- **Characteristics** - Used to define characteristics for the member person.

The **Main** section contains the following fields:

Field Name	Field Description	Mandatory (Yes or No)
Membership Information	Indicates the membership to which the person is added.	Not applicable
Person ID	Indicates the person who is added to the membership.	Not applicable
Relationship Type	Used to indicate how the person is related to the main subscriber.	Yes
Financially Responsible	Used to indicate whether the person is financially responsible for the membership.	No
Main Subscriber	Used to indicate whether the person is the main subscriber of the membership.	No
Member	Used to indicate whether the person is added as a member to the membership.	No
Start Date	Used to specify the date from when you want to add the person to the membership.  <div style="border: 1px solid black; padding: 5px;"> <p><b>Note:</b> The member person start date cannot be later than the member person end date. The member person start date cannot be earlier than the membership start date or later than the membership end date.</p> </div>	Yes
End Date	Used to specify the date till when you want to add the person to the membership.  <div style="border: 1px solid black; padding: 5px;"> <p><b>Note:</b> The member person end date cannot be earlier than the member person start date. The member person end date cannot be earlier than the membership start date or later than the membership end date.</p> </div>	No

Field Name	Field Description	Mandatory (Yes or No)
Membership Person Status	<p>Used to indicate the status of the member person. The valid values are:</p> <ul style="list-style-type: none"> <li>Active</li> <li>Inactive</li> </ul> <p><b>Note:</b></p> <p>If you inactivate a member person who is the main subscriber, the system automatically inactivates the membership and all other member persons which are included in the membership.</p> <p>You cannot change the status of the member person to <b>Active</b> when the membership is in the <b>Inactive</b> status.</p>	Yes

- Modify the required details in the **Main** section.
- Define, edit, or remove the characteristics from the member person, if required.
- Click **Save**.

The changes made to the membership details of the person are saved.

#### Related Topics

For more information on...	See...
How to search for a membership	<a href="#">Searching for a Membership</a> on page 2133
<b>Membership</b> screen	<a href="#">Membership (Used for Viewing)</a> on page 2138
<b>Member Persons</b> zone	<a href="#">Member Persons</a> on page 2141
How to define a characteristic for a member person	<a href="#">Defining a Characteristic for a Member Person</a> on page 2152
How to inactivate a member person of a membership	<a href="#">Inactivating a Member Person</a> on page 2154

## Associating a Contract with a Membership

### Prerequisites

To associate a contract with a membership, you should have:

- Contracts defined in the application
- Values defined for the **BILL\_TO\_TYPE\_FLG** lookup field

### Procedure

To associate a contract with a membership:

- Search for the membership in the **Membership** screen.
- In the **Search Results** section, click the link in the **Membership Information** column corresponding to the membership to which you want to associate a contract.

The **Membership** screen appears.

- Click the **Contracts and Charges** tab.

The **Contracts and Charges** tab appears.

- Click the **Add Contract** link in the upper right corner of the **Membership Contracts** zone.

The **Associate Contract with Membership** screen appears. It contains the following section:

- Main** - Used to associate a contract with the membership. It contains the following fields:

Field Name	Field Description	Mandatory (Yes or No)
Membership Information	Indicates the membership to which you want to associate a contract.	Not applicable
Contract ID	Used to indicate the contract that you want to associate with the membership.  <b>Note:</b> The <b>Search</b>  icon appears corresponding to the <b>Contract ID</b> field. On clicking the <b>Search</b> icon, the <b>Contract Search</b> window appears.	Yes
Bill To	Used to indicate the entity against whom the corresponding charges should be billed. The valid values are: <ul style="list-style-type: none"> <li>Federal</li> <li>State</li> <li>Group</li> <li>Individual</li> </ul> <b>Note:</b> You cannot associate multiple contracts with the membership using the same bill to option. For example, you cannot associate C1 and C2 with M1 by selecting the <b>Group</b> option from the <b>Bill To</b> field.	Yes
Start Date	Used to specify the date from when you want to associate the contract with the membership.  <b>Note:</b> The start date cannot be later than end date. The start date cannot be earlier than the membership start date or later than the membership end date.	Yes
End Date	Used to specify the date till when you want to associate the contract with the membership.  <b>Note:</b> The end date cannot be earlier than the start date. The end date cannot be earlier than the membership start date or later than the membership end date.	No

- Enter the required details in the **Main** section.
- Click **Save**.

The contract is associated with the membership.

### Related Topics

For more information on...	See...
How to search for a membership	<a href="#">Searching for a Membership</a> on page 2133
<b>Membership</b> screen	<a href="#">Membership (Used for Viewing)</a> on page 2138
<b>Membership Contracts</b> zone	<a href="#">Membership Contracts</a> on page 2143

## Disassociating a Contract from a Membership

### Procedure

To disassociate a contract from a membership:

1. Search for the membership in the **Membership** screen.
2. In the **Search Results** section, click the link in the **Membership Information** column corresponding to the membership from which you want to disassociate the contract.

The **Membership** screen appears.

3. Click the **Contract & Charges** tab.

The **Contract & Charges** tab appears.

4. In the **Membership Contracts** zone, click the **Delete** (🗑️) icon in the **Delete** column corresponding to the contract that you want to disassociate from the membership.

A message appears confirming whether you want to disassociate the contract from the membership.

5. Click **OK**.

The contract is disassociated from the membership.

### Related Topics

For more information on...	See...
How to search for a membership	<a href="#">Searching for a Membership</a> on page 2133
<b>Membership</b> screen	<a href="#">Membership (Used for Viewing)</a> on page 2138
<b>Membership Contracts</b> zone	<a href="#">Membership Contracts</a> on page 2143

## Editing the Contract Association Details of a Membership

### Prerequisites

To edit the contract association details of a membership, you should have:

- Contracts defined in the application
- Values defined for the **BILL\_TO\_TYPE\_FLG** lookup field

### Procedure

To edit the contract association details of a membership:

1. Search for the membership in the **Membership** screen.
2. In the **Search Results** section, click the link in the **Membership Information** column corresponding to the membership whose contract details you want to edit.

The **Membership** screen appears.

3. Click **Contracts and Charges** tab.

The **Contracts and Charges** tab appears.

4. In the **Membership Contracts** zone, click the **Edit** (✎) icon in the **Edit** column corresponding to the contract whose association details you want to edit.

The **Associate Contract with Membership** screen appears. It contains the following section:

- **Main** - Used to associate a contract with the membership. It contains the following fields:

Field Name	Field Description	Mandatory (Yes or No)
Membership Information	Indicates the membership to which you want to associate a contract.	Not applicable
Contract ID	Used to indicate the contract that you want to associate with the membership.  <b>Note:</b> The <b>Search</b> (🔍) icon appears corresponding to the <b>Contract ID</b> field. On clicking the <b>Search</b> icon, the <b>Contract Search</b> window appears.	Yes
Bill To	Used to indicate the entity against whom the corresponding charges should be billed. The valid values are: <ul style="list-style-type: none"> <li>• Federal</li> <li>• State</li> <li>• Group</li> <li>• Individual</li> </ul> <b>Note:</b> You cannot associate multiple contracts with the membership using the same bill to option. For example, you cannot associate C1 and C2 with M1 by selecting the <b>Group</b> option from the <b>Bill To</b> field.	Yes
Start Date	Used to specify the date from when you want to associate the contract with the membership.  <b>Note:</b> The start date cannot be later than end date. The start date cannot be earlier than the membership start date or later than the membership end date.	Yes
End Date	Used to specify the date till when you want to associate the contract with the membership.  <b>Note:</b> The end date cannot be earlier than the start date. The end date cannot be earlier than the membership start date or later than the membership end date.	No



5. Modify the required details in the **Main** section.
6. Click **Save**.

The changes made to the membership are saved.

#### Related Topics

For more information on...	See...
How to search for a membership	<a href="#">Searching for a Membership</a> on page 2133
<b>Membership</b> screen	<a href="#">Membership (Used for Viewing)</a> on page 2138
<b>Membership Contracts</b> zone	<a href="#">Membership Contracts</a> on page 2143

## Viewing the Billable Charges Created for a Membership

### Procedure

To view the billable charges created for a membership:

1. Search for the membership in the **Membership** screen.
2. In the **Search Results** section, click the link in the **Membership Information** column corresponding to the membership whose details you want to view.  
The **Membership** screen appears.
3. Click the **Contracts and Charges** tab.  
The **Contracts and Charges** tab appears.
4. View the billable charges created for the membership in the **Billable Charges** zone.

#### Related Topics

For more information on...	See...
How to search for a membership	<a href="#">Searching for a Membership</a> on page 2133
<b>Membership</b> screen	<a href="#">Membership (Used for Viewing)</a> on page 2138
<b>Billable Charges</b> zone	<a href="#">Billable Charges</a> on page 2144

## Viewing the Bill Segments Generated for a Billable Charge

### Procedure

To view the bill segments generated for a billable charge:

1. Search for the membership in the **Membership** screen.
2. In the **Search Results** section, click the link in the **Membership Information** column corresponding to the membership whose details you want to view.  
The **Membership** screen appears.
3. Click the **Contracts and Charges** tab.  
The **Contracts and Charges** tab appears.
4. In the **Billable Charges** zone, click the **Broadcast**  icon corresponding to the billable charge whose bill segments you want to view.  
The **Bill Segment Details** and **Billable Charge Timeline Details** zones appear.
5. View the bill segments generated for the billable charge in the **Bill Segment Details** zone.

**Related Topics**

<b>For more information on...</b>	
How to search for a membership	<a href="#">Searching for a Membership</a> on page 2133
<b>Membership</b> screen	<a href="#">Membership (Used for Viewing)</a> on page 2138
<b>Billable Charges</b> zone	<a href="#">Billable Charges</a> on page 2144
<b>Bill Segment Details</b> zone	<a href="#">Bill Segment Details</a> on page 2146
<b>Billable Charge Timeline Details</b> zone	<a href="#">Billable Charge Timeline Details</a> on page 2147

**Viewing the Timeline Details of a Membership Billable Charge****Procedure**

To view the timeline details of a membership billable charge:

1. Search for the membership in the **Membership** screen.
2. In the **Search Results** section, click the link in the **Membership Information** column corresponding to the membership whose details you want to view.  
The **Membership** screen appears.
3. Click the **Contracts and Charges** tab.  
The **Contracts and Charges** tab appears.
4. In the **Billable Charges** zone, click the **Broadcast**  icon corresponding to the billable charge whose timeline details you want to view.  
The **Bill Segment Details** and **Billable Charge Timeline Details** zones appear.
5. View the timeline details of the billable charge in the **Billable Charge Timeline Details** zone.

**Related Topics**

<b>For more information on...</b>	
How to search for a membership	<a href="#">Searching for a Membership</a> on page 2133
<b>Membership</b> screen	<a href="#">Membership (Used for Viewing)</a> on page 2138
<b>Billable Charges</b> zone	<a href="#">Billable Charges</a> on page 2144
<b>Bill Segment Details</b> zone	<a href="#">Bill Segment Details</a> on page 2146
<b>Billable Charge Timeline Details</b> zone	<a href="#">Billable Charge Timeline Details</a> on page 2147

**Viewing the Pricing Calculation Details of a Timeline****Procedure**

To view the pricing calculation details of a timeline:

1. Search for the membership in the **Membership** screen.
2. In the **Search Results** section, click the link in the **Membership Information** column corresponding to the membership whose details you want to view.  
The **Membership** screen appears.
3. Click the **Contracts and Charges** tab.  
The **Contracts and Charges** tab appears.

- In the **Billable Charges** zone, click the **Broadcast**  icon corresponding to the billable charge whose timeline details you want to view.

The **Bill Segment Details** and **Billable Charge Timeline Details** zones appear.

- In the **Billable Charge Timeline Details** zone, click the **Broadcast**  icon corresponding to the timeline whose pricing calculation details you want to view.
- View the base fee and modifier fee (if any) applicable for each eligible member or membership in the **Pricing Calculation Details** zone.

### Related Topics

For more information on...	
How to search for a membership	<a href="#">Searching for a Membership</a> on page 2133
<b>Membership</b> screen	<a href="#">Membership (Used for Viewing)</a> on page 2138
<b>Billable Charges</b> zone	<a href="#">Billable Charges</a> on page 2144
<b>Bill Segment Details</b> zone	<a href="#">Bill Segment Details</a> on page 2146
<b>Billable Charge Timeline Details</b> zone	<a href="#">Billable Charge Timeline Details</a> on page 2147
<b>Pricing Calculation Details</b> zone	<a href="#">Pricing Calculation Details</a> on page 2147

## Viewing the Log of a Membership

### Procedure

To view the log of a membership:

- Search for the membership in the **Membership** screen.
- In the **Search Results** section, click the link in the **Membership Information** column corresponding to the membership whose details you want to view.

The **Membership** screen appears.

- Click the **Log** tab.

The **Log** tab appears.

- View the complete trail of actions performed on the membership in the **Membership Log** zone.

### Related Topics

For more information on...	See...
How to search for a membership	<a href="#">Searching for a Membership</a> on page 2133
<b>Membership</b> screen	<a href="#">Membership (Used for Viewing)</a> on page 2138
<b>Membership Log</b> zone	<a href="#">Membership Log</a> on page 2148
How to add a log entry for a membership	<a href="#">Adding a Log Entry for a Membership</a> on page 2163

## Adding a Log Entry for a Membership

### Procedure

To add a log entry for a membership:

- Search for the membership in the **Membership** screen.

- In the **Search Results** section, click the link in the **Membership Information** column corresponding to the membership for which you want to add a log entry.

The **Membership** screen appears.

- Click the **Log** tab.

The **Log** tab appears.

- Click the **Add Log Entry** link in the upper right corner of the **Membership Log** zone.

The **Add Membership Log** window appears. It contains the following fields:

Field Name	Field Description	Mandatory (Yes or No)
Membership Information	Displays information about the membership.	Not applicable
Log Details	Used to specify additional comments on the membership.	Yes

- Enter the comments in the **Log Details** field.

- Click **Save**.

The log entry is added in the **Membership Log** zone.

#### **Related Topics**

For more information on...	See...
How to search for a membership	<a href="#">Searching for a Membership</a> on page 2133
<b>Membership</b> screen	<a href="#">Membership (Used for Viewing)</a> on page 2138
<b>Membership Log</b> zone	<a href="#">Membership Log</a> on page 2148

---

# Chapter 29

---

## Upload Lockbox Payment and Remittance Advices Overview

---

### Topics:

- [Prerequisites](#)
- [EDI 820 Flat File Description](#)
- [Sample EDI 820 Flat File](#)
- [Upload EDI 820 Files in ORMB](#)

Oracle Revenue Management and Billing enables you to upload lockbox payment and remittance advices received in the **Electronic Data Exchange (EDI) 820** format. Under this feature, the payments made by customers are directed to a special post office box instead of going to the company directly. The bank goes to this post office box, retrieves the payments, processes them and deposits the funds directly into the company's bank account.

An EDI 820 payment order or remittance advice is an electronic document that can be used to initiate payments and send remittance information. EDI 820 sends information to vendor furnishing details of payment for his supplies. A remittance advice is a note sent from a customer to their supplier, informing the supplier that they have paid their invoice. The advice may contain elements such as a text note, the invoice number and the invoice amount, among others. Remittance advice is not required, but they are seen as a courtesy since they make it easier for the supplier to match invoices with payments.

To enable this feature, lockbox payment files are required to be uploaded on ORMB and these files has to be allocated to the appropriate accounts. To support multiple lines of business, the lockbox upload needs to:

- Consider the primary identifier when looking for a source customer number match. For customers having multiple source system identifiers, the lockbox process only matches against the one identified as primary customer.
- Incorporate the payment allocation logic in the system on the basis of which the lockbox uploads the payments for the identified customer.

To support remittances which can split a tender across multiple customers:

- Allow source customer number or tax id to be provided as remittance (RMR) values. In case of multiple source customer number or tax id, remittance values are provided for a single tender, the account associated with the first remittance value is set as the payor account. If there is at least one remittance value where a single customer account cannot be determined, the entire tender is placed into general suspense.
- A new payment upload batch **C1-PUPSG** is developed to read lockbox payment files from the bank and load the payment details into the ORMB payment upload staging tables for processing.
- Once the text file is uploaded, the deposit control staging, tender control staging, and payment upload staging records are created in the respective tables. You can then execute the **Payment Upload (PUPL)** batch to create the deposit control, tender controls, payment events, tenders,

payments, and payment segments using payment records in the staging area.

**Note:** For more information about the batches, refer to the *Oracle Revenue Management and Billing Batch Guide*.

#### **Related Topics**

<b>For more information on...</b>	<b>See...</b>
<b>Prerequisites</b>	<a href="#">Prerequisites</a> on page 2167
<b>EDI 820 Flat File Description</b>	<a href="#">EDI 820 Flat File Description</a> on page 2167
<b>Sample EDI 820 Flat File</b>	<a href="#">Sample EDI 820 Flat File</a> on page 2169
<b>Upload EDI 820 Files in ORMB</b>	<a href="#">Upload EDI 820 Files in ORMB</a> on page 2172

## Prerequisites

---

To setup the upload lockbox payment process, you need to do the following:

- Define the values in the parameters of the **C1-CCPYTSADS** and **C1-MATSATYP** algorithms.
- Lockbox tender types defined in the **C1\_LBX\_TENDER\_TYPE** lookup field.
- Lockbox record type, lockbox reference identification qualifier, and lockbox remittance identification types defined in the **C1\_LBX\_820\_RECORD\_TYPE**, **C1\_LBX\_REF\_IDQ\_LKP**, and **C1\_LBX\_RMR\_ID\_TYPE** lookup fields respectively.

## EDI 820 Flat File Description

---

Following is the description of the key field segments in the EDI 820 flat file format:

Field Name	Description
External Source ID	Uniquely identifies the lockbox.
External Transmission ID	Uniquely identifies the transmission. To ensure this transmission, the date component (such as, 20150813) should match the deposit date and there should only be one file per deposit date.
External Batch ID	Uniquely identifies the batch of payments in a transmission. To ensure these payments, if there are multiple ST records in a file, the transaction set control number (such as, 0101, 0202, ..) should be unique.

Field Name	Description																										
Payment Transaction	<p>The following table describes the fields that are included in the payment transaction:</p> <table border="1" data-bbox="548 262 1471 2026"> <thead> <tr> <th data-bbox="548 262 898 312">Field</th> <th data-bbox="898 262 1471 312">Description</th> </tr> </thead> <tbody> <tr> <td data-bbox="548 312 898 594">Attributes</td> <td data-bbox="898 312 1471 594"> <p>Following are the attributes of payment transaction:</p> <ul style="list-style-type: none"> <li>• Payment Amount</li> <li>• Payment Method</li> <li>• Payment Date</li> <li>• Payor Name</li> </ul> </td> </tr> <tr> <td data-bbox="548 594 898 1648">Reference Records</td> <td data-bbox="898 594 1471 1648"> <p>Uniquely identifies the transaction. This is retrieved from different reference records based on the payment method. The following table indicates the external reference ID based on the payment methods used in the transaction:</p> <table border="1" data-bbox="909 783 1446 1627"> <thead> <tr> <th data-bbox="909 783 1144 898">External Reference Value</th> <th data-bbox="1144 783 1446 898">Description</th> </tr> </thead> <tbody> <tr> <td data-bbox="909 898 1144 1045">ACH</td> <td data-bbox="1144 898 1446 1045">Use the automated clearinghouse trace number. (Reference Identifier Code is 8G).</td> </tr> <tr> <td data-bbox="909 1045 1144 1192">CHK</td> <td data-bbox="1144 1045 1446 1192">Use the transaction reference number. (Reference Identifier Code TN).</td> </tr> <tr> <td data-bbox="909 1192 1144 1339">FWT</td> <td data-bbox="1144 1192 1446 1339">Use the FEDWIRE confirmation number. (Reference Identifier Code 8I).</td> </tr> <tr> <td data-bbox="909 1339 1144 1486">CAS</td> <td data-bbox="1144 1339 1446 1486">Use the transaction reference number. (Reference Identifier Code TN).</td> </tr> <tr> <td data-bbox="909 1486 1144 1627">OBP</td> <td data-bbox="1144 1486 1446 1627">Use the online payment trace number. (Reference Identifier Code 8G).</td> </tr> </tbody> </table> </td> </tr> <tr> <td data-bbox="548 1648 898 1764">Source Customer Number</td> <td data-bbox="898 1648 1471 1764">Uniquely identifies the customer. This is retrieved from the internal customer number reference record. (Reference Identifier Code is IT).</td> </tr> <tr> <td data-bbox="548 1764 898 1843">MICR</td> <td data-bbox="898 1764 1471 1843">Uniquely identifies the MICR. (Reference Identifier Code is MICR)</td> </tr> <tr> <td data-bbox="548 1843 898 1923">Check Number</td> <td data-bbox="898 1843 1471 1923">Uniquely identifies the check number. (Reference Identifier Code is CK)</td> </tr> <tr> <td data-bbox="548 1923 898 2026">Taxpayer Identification Number</td> <td data-bbox="898 1923 1471 2026">Uniquely Identifies the taxpayer. (Reference Identifier Code is EI)</td> </tr> </tbody> </table>	Field	Description	Attributes	<p>Following are the attributes of payment transaction:</p> <ul style="list-style-type: none"> <li>• Payment Amount</li> <li>• Payment Method</li> <li>• Payment Date</li> <li>• Payor Name</li> </ul>	Reference Records	<p>Uniquely identifies the transaction. This is retrieved from different reference records based on the payment method. The following table indicates the external reference ID based on the payment methods used in the transaction:</p> <table border="1" data-bbox="909 783 1446 1627"> <thead> <tr> <th data-bbox="909 783 1144 898">External Reference Value</th> <th data-bbox="1144 783 1446 898">Description</th> </tr> </thead> <tbody> <tr> <td data-bbox="909 898 1144 1045">ACH</td> <td data-bbox="1144 898 1446 1045">Use the automated clearinghouse trace number. (Reference Identifier Code is 8G).</td> </tr> <tr> <td data-bbox="909 1045 1144 1192">CHK</td> <td data-bbox="1144 1045 1446 1192">Use the transaction reference number. (Reference Identifier Code TN).</td> </tr> <tr> <td data-bbox="909 1192 1144 1339">FWT</td> <td data-bbox="1144 1192 1446 1339">Use the FEDWIRE confirmation number. (Reference Identifier Code 8I).</td> </tr> <tr> <td data-bbox="909 1339 1144 1486">CAS</td> <td data-bbox="1144 1339 1446 1486">Use the transaction reference number. (Reference Identifier Code TN).</td> </tr> <tr> <td data-bbox="909 1486 1144 1627">OBP</td> <td data-bbox="1144 1486 1446 1627">Use the online payment trace number. (Reference Identifier Code 8G).</td> </tr> </tbody> </table>	External Reference Value	Description	ACH	Use the automated clearinghouse trace number. (Reference Identifier Code is 8G).	CHK	Use the transaction reference number. (Reference Identifier Code TN).	FWT	Use the FEDWIRE confirmation number. (Reference Identifier Code 8I).	CAS	Use the transaction reference number. (Reference Identifier Code TN).	OBP	Use the online payment trace number. (Reference Identifier Code 8G).	Source Customer Number	Uniquely identifies the customer. This is retrieved from the internal customer number reference record. (Reference Identifier Code is IT).	MICR	Uniquely identifies the MICR. (Reference Identifier Code is MICR)	Check Number	Uniquely identifies the check number. (Reference Identifier Code is CK)	Taxpayer Identification Number	Uniquely Identifies the taxpayer. (Reference Identifier Code is EI)
Field	Description																										
Attributes	<p>Following are the attributes of payment transaction:</p> <ul style="list-style-type: none"> <li>• Payment Amount</li> <li>• Payment Method</li> <li>• Payment Date</li> <li>• Payor Name</li> </ul>																										
Reference Records	<p>Uniquely identifies the transaction. This is retrieved from different reference records based on the payment method. The following table indicates the external reference ID based on the payment methods used in the transaction:</p> <table border="1" data-bbox="909 783 1446 1627"> <thead> <tr> <th data-bbox="909 783 1144 898">External Reference Value</th> <th data-bbox="1144 783 1446 898">Description</th> </tr> </thead> <tbody> <tr> <td data-bbox="909 898 1144 1045">ACH</td> <td data-bbox="1144 898 1446 1045">Use the automated clearinghouse trace number. (Reference Identifier Code is 8G).</td> </tr> <tr> <td data-bbox="909 1045 1144 1192">CHK</td> <td data-bbox="1144 1045 1446 1192">Use the transaction reference number. (Reference Identifier Code TN).</td> </tr> <tr> <td data-bbox="909 1192 1144 1339">FWT</td> <td data-bbox="1144 1192 1446 1339">Use the FEDWIRE confirmation number. (Reference Identifier Code 8I).</td> </tr> <tr> <td data-bbox="909 1339 1144 1486">CAS</td> <td data-bbox="1144 1339 1446 1486">Use the transaction reference number. (Reference Identifier Code TN).</td> </tr> <tr> <td data-bbox="909 1486 1144 1627">OBP</td> <td data-bbox="1144 1486 1446 1627">Use the online payment trace number. (Reference Identifier Code 8G).</td> </tr> </tbody> </table>	External Reference Value	Description	ACH	Use the automated clearinghouse trace number. (Reference Identifier Code is 8G).	CHK	Use the transaction reference number. (Reference Identifier Code TN).	FWT	Use the FEDWIRE confirmation number. (Reference Identifier Code 8I).	CAS	Use the transaction reference number. (Reference Identifier Code TN).	OBP	Use the online payment trace number. (Reference Identifier Code 8G).														
External Reference Value	Description																										
ACH	Use the automated clearinghouse trace number. (Reference Identifier Code is 8G).																										
CHK	Use the transaction reference number. (Reference Identifier Code TN).																										
FWT	Use the FEDWIRE confirmation number. (Reference Identifier Code 8I).																										
CAS	Use the transaction reference number. (Reference Identifier Code TN).																										
OBP	Use the online payment trace number. (Reference Identifier Code 8G).																										
Source Customer Number	Uniquely identifies the customer. This is retrieved from the internal customer number reference record. (Reference Identifier Code is IT).																										
MICR	Uniquely identifies the MICR. (Reference Identifier Code is MICR)																										
Check Number	Uniquely identifies the check number. (Reference Identifier Code is CK)																										
Taxpayer Identification Number	Uniquely Identifies the taxpayer. (Reference Identifier Code is EI)																										



Field Name	Description												
Remittance Advice	<p>The following table describes the fields that are involved in the remittance advice:</p> <table border="1"> <thead> <tr> <th>Field</th> <th>Description</th> </tr> </thead> <tbody> <tr> <td>Attributes</td> <td> <p>Following are the attributes:</p> <ul style="list-style-type: none"> <li>• Invoice Number</li> <li>• Payment Amount</li> </ul> </td> </tr> <tr> <td>Reference Records</td> <td> <p>Uniquely identifies the remittance advice. The following table indicates the external reference ID based on the payment methods used in the remittance advice:</p> <table border="1"> <thead> <tr> <th>External Reference ID Value</th> <th>Description</th> </tr> </thead> <tbody> <tr> <td>Billing Account ID</td> <td>Uniquely identifies the account. (Reference Identifier Code is 12).</td> </tr> <tr> <td>Bill Group ID</td> <td>Uniquely identifies the billing group. (Reference Identifier Code is U1).</td> </tr> </tbody> </table> </td> </tr> </tbody> </table>	Field	Description	Attributes	<p>Following are the attributes:</p> <ul style="list-style-type: none"> <li>• Invoice Number</li> <li>• Payment Amount</li> </ul>	Reference Records	<p>Uniquely identifies the remittance advice. The following table indicates the external reference ID based on the payment methods used in the remittance advice:</p> <table border="1"> <thead> <tr> <th>External Reference ID Value</th> <th>Description</th> </tr> </thead> <tbody> <tr> <td>Billing Account ID</td> <td>Uniquely identifies the account. (Reference Identifier Code is 12).</td> </tr> <tr> <td>Bill Group ID</td> <td>Uniquely identifies the billing group. (Reference Identifier Code is U1).</td> </tr> </tbody> </table>	External Reference ID Value	Description	Billing Account ID	Uniquely identifies the account. (Reference Identifier Code is 12).	Bill Group ID	Uniquely identifies the billing group. (Reference Identifier Code is U1).
Field	Description												
Attributes	<p>Following are the attributes:</p> <ul style="list-style-type: none"> <li>• Invoice Number</li> <li>• Payment Amount</li> </ul>												
Reference Records	<p>Uniquely identifies the remittance advice. The following table indicates the external reference ID based on the payment methods used in the remittance advice:</p> <table border="1"> <thead> <tr> <th>External Reference ID Value</th> <th>Description</th> </tr> </thead> <tbody> <tr> <td>Billing Account ID</td> <td>Uniquely identifies the account. (Reference Identifier Code is 12).</td> </tr> <tr> <td>Bill Group ID</td> <td>Uniquely identifies the billing group. (Reference Identifier Code is U1).</td> </tr> </tbody> </table>	External Reference ID Value	Description	Billing Account ID	Uniquely identifies the account. (Reference Identifier Code is 12).	Bill Group ID	Uniquely identifies the billing group. (Reference Identifier Code is U1).						
External Reference ID Value	Description												
Billing Account ID	Uniquely identifies the account. (Reference Identifier Code is 12).												
Bill Group ID	Uniquely identifies the billing group. (Reference Identifier Code is U1).												

You can refer the following sample of EDI 820 flat file for better understanding:

[Sample EDI 820 Flat File](#) on page 2169

## Sample EDI 820 Flat File

Following is the sample of EDI 820 flat file format:

ISA\*00\*\*00\*\*ZZ\*USBANK\*ZZ\*UHGI\*081315\*1013\*U\*00401\*000000005\*0\*P\*|~

GS\*RA\*USBBRSLBX\*UHGI\*20150813\*1013\*4\*X\*004010~

**/\*\* This is for a batch of ACH payments, with 2 ACH transactions, each with one remittance advice \*\*/**

ST\*ACH\*000000001~

BPR\*D\*9135.79\*C\*ACH\*\*\*\*\*104791546344\*20150813~

REF\*8G\*0210000210000000~ **/\*\* This is the Automated Clearinghouse (ACH) Trace Number**

REF\*IT\*09R7680~ **/\*\* This is the Source Customer Number**

RMR\*IV\*117122276200\*\*9135.79~ **/\*\* This is the BRMS Invoice ID (from scan line) and the Amount Paid for the Invoice**

BPR\*D\*40000.79\*C\*ACH\*\*\*\*\*104791546344\*20150813~

REF\*8G\*0210000560000000~

REF\*IT\*0738148~

RMR\*IV\*117122276200\*\*9135.79~

SE\*2\*00000001~ /\*\* 2 is the count of BPR records in the set, 00000001 is the control number of the set header  
 /\*\* This is for a batch of Check payments, where there are 7 Check transactions \*\*/  
 ST\*CHK\*00000002~  
 /\*\*\*\*\* 1 check pays 1 invoice \*\*\*\*\*/  
 BPR\*D\*4000.00\*C\*CHK\*\*\*\*\*104791546344\*20150813~  
 REF\*TN\*7228595404~ /\*\* This is the Transaction Reference Number (unique identifier for transaction)  
 REF\*IT\*0920193~ /\*\* This is the Source Customer Number  
 REF\*CK\*7228595~ /\*\* This is the Check Number  
 REF\*EI\*99999999~ /\*\* This is the Taxpayer Identification Number  
 REF\*MN\*02100021000123456~ /\*\* This is the MICR Number  
 RMR\*IV\*877121234200\*\*4000.00~ /\*\* This is the BRMS Invoice ID and the Amount Paid for the Invoice  
 REF\*12\*8771281929~ /\*\* This is the BRMS Account ID  
 REF\*U1\*001~ /\*\* This is the Account Number, which is Bill Group ID  
 /\*\*\*\*\* 2 checks pays 1 invoice (invoice total is \$3600.00) \*\*\*\*\*/  
 BPR\*D\*1800.00\*C\*CHK\*\*\*\*\*104791546344\*20150813~  
 REF\*TN\*000243404~  
 REF\*IT\*0822930~  
 REF\*CK\*0000243~  
 REF\*MN\*02100021000120000~  
 RMR\*IV\*839221223382\*\*1800.00~  
 REF\*12\*8392281929~  
 REF\*U1\*001~  
 BPR\*D\*1800.00\*C\*CHK\*\*\*\*\*104791546344\*20150813~  
 REF\*TN\*000244404~  
 REF\*IT\*0822930~  
 REF\*CK\*0000244~  
 REF\*MN\*02100021000120000~  
 RMR\*IV\*839221223382\*\*1800.00~  
 REF\*12\*8392281929~  
 REF\*U1\*001~  
 /\*\*\*\*\* 2 checks pays 1 invoice (invoice total is \$3600.00), invoice not fully paid (i.e. 2nd check only for \$1600.00  
 \*\*\*\*\*/  
 BPR\*D\*1800.00\*C\*CHK\*\*\*\*\*104791546344\*20150813~  
 REF\*TN\*003001404~  
 REF\*IT\*0522789~  
 REF\*CK\*0003001~  
 REF\*MN\*02100021000123300~  
 RMR\*IV\*972221223382\*\*1800.00~

REF\*12\*9722281929~

REF\*U1\*001~

BPR\*D\*1600.00\*C\*CHK\*\*\*\*\*104791546344\*20150813~

REF\*TN\*003002404~

REF\*IT\*0522789~

REF\*CK\*0003002~

REF\*MN\*021000021000123300~

RMR\*IV\*972221223382\*\*1600.00~

REF\*12\*9722281929~

REF\*U1\*001~

/\*\*\*\*\* 1 check pays 2 invoices belonging to the same account \*\*\*\*\*/

BPR\*D\*1800.00\*C\*CHK\*\*\*\*\*104791546344\*20150813~

REF\*TN\*1232833404~

REF\*IT\*0334920~

REF\*CK\*1232833~

REF\*MN\*021000021000997649~

RMR\*IV\*345124829323\*\*1000.00~

REF\*12\*3451234181~

REF\*U1\*001~

RMR\*IV\*345121739412\*\*800.00~ REF\*12\*3451234181~

REF\*U1\*001~

/\*\*\*\*\* 1 check pays 2 invoices belonging to different accounts \*\*\*\*\*/

BPR\*D\*1800.00\*C\*CHK\*\*\*\*\*104791546344\*20150813~

REF\*TN\*8437628404~

REF\*IT\*0239921~

REF\*CK\*8437628~

REF\*MN\*021000021000327643~

RMR\*IV\*049014829321\*\*1000.00~

REF\*12\*0490123444~

REF\*U1\*001~

RMR\*IV\*367121739609\*\*800.00~

REF\*12\*3671234100~

REF\*U1\*001~ SE\*7\*000000002~

/\*\* 7 is the count of BPR records in the set, 000000002 is the control number of the set header

/\*\* This is for a batch of Wire payments, with 1 Wire transaction with one remittance advice \*\*/

ST\*FWT\*000000003~

BPR\*D\*1500.79\*C\*FWT\*\*\*\*\*104791546344\*20150813~

REF\*8I\*0210000210000999~ /\*\* This is the FEDWIRE Confirmation Number

REF\*IT\*072A980~ /\*\* This is the Source Customer Number

SE\*000000001\*00000003~ /\*\* 000000001 is the count of BPR records in the set, 00000003 is the control number of the set header

/\*\* This is for a batch of Cash payments, with 1 Cash transaction with one remittance advice \*\*/

ST\*CAS\*000000004~

BPR\*D\*6000.00\*C\*CAS\*\*\*\*\*104791546344\*20150813~

REF\*TN\*0210000210000888~ /\*\* This is the Transaction Reference Number (unique identifier for transaction)

REF\*IT\*066B987~ /\*\* This is the Source Customer Number

REF\*MN\*021000021077777700~ /\*\* This is the alternative to MICR for Cash Items

RMR\*IV\*234868822762\*\*6000.00~ /\*\* This is the BRMS Invoice ID and the Amount Paid for the Invoice

REF\*12\*2348618887~ /\*\* This is the BRMS Account ID

REF\*U1\*001~ /\*\* This is the Account Number, aka Bill Group ID

SE\*1\*000000004~ /\*\* 1 is the count of BPR records in the set, 00000004 is the control number of the set header

/\*\* This is for a batch of E-Lockbox payments, with 1 E-Lockbox transaction with one remittance advice \*\*/

ST\*OBP\*000000005~

BPR\*D\*3100.00\*C\*OBP\*\*\*\*\*104791546344\*20150813~

N1\*PR\*Company AAA~ /\*\* This is the Customer Name

REF\*8G\*0210000210001111~ /\*\* This is the Online Payment Trace Number

REF\*IT\*09C8780~ /\*\* - Source Customer Number

SE\*1\*000000005~ /\*\* 1 is the count of BPR records in the set, 00000005 is the control number of the set header

GE\*5\*4~ /\*\* 5 is the count of transaction sets (SE) in the group, 4 is the group control number of the group header

IEA\*1\*000000005~

### Related Topics

For more information on...	See...
EDI 820 flat file format description	<a href="#">EDI 820 Flat File Description</a> on page 2167

## Upload EDI 820 Files in ORMB

A new batch named **Lockbox Payment Upload - Small Group (C1-PUPSG)** is introduced in this release. This batch is used to read the EDI 820 lockbox file received from the bank containing payment details for accounts and uploads the payment details into the ORMB payment upload staging tables. The batch uses the reference ID available in the payment and remittance record (in the specified order) to identify the account in the system:

- Source System Customer Number
- Invoice ID (if the source system customer number is not available)
- MICR (if the source system customer number and invoice ID are not available)

If all three reference IDs are available in the payment and remittance record, the system uses the source system customer number to identify the customer in ORMB. If the customer is found in ORMB, the system then checks whether the identified customer has an account. If the identified customer has one account, the system checks the following:

- If the **Check Binder Payment** parameter in the **Pay Tender Staging Account Distribution - Pay Oldest Bill First (C1-CCPYTSADS)** algorithm is set to Y, the system checks whether the payment is the first payment for

the account and the tender used for the payment is not automatic payment. If so, the payment is applied to the **Binder Payment** contract.

- If the **Check Promise To Pay** parameter in the **Tender Staging Account Distribution - Pay Oldest Bill First (C1-CCPYTSADS)** algorithm is set to **Y**, the system checks whether there is an active promise to pay for the account. If so, the payment is applied to the **On Account** contract.
- If the **Check Payment Agreement** parameter in the **Tender Staging Account Distribution - Pay Oldest Bill First (C1-CCPYTSADS)** algorithm is set to **Y**, the system checks whether there is an active payment agreement request for the account. If so, the payment is applied to the **On Account** contract.

However, if the **Check Binder Payment**, **Check Promise To Pay**, and **Check Payment Agreement** parameters are set to **N**, the payment is applied to the account's open bills in the order of the due date (i.e. oldest bill first). If the payment amount is greater than the account's billed balance plus overpayment threshold amount (defined in the **Tender Staging Account Distribution - Pay Oldest Bill First (C1-CCPYTSADS)** algorithm), the entire amount is applied on the On Account contract. However, if the payment amount is greater than the account's billed balance, but less than account's billed balance plus overpayment threshold amount, the overpayment amount is applied on the On Account contract.

Let us understand this with the help of an example:

Payment Amount	Bill 1 (Due Date 01-Feb-2017)	Bill 2 (Due Date 01-April-2016)	Overpayment Threshold Amount	System Behavior
100	50	50	50	One payment (50\$) is created for Bill 2 (oldest due date); One payment (50\$) is created for Bill 1.
150	50	100	120	One payment (100\$) is created for Bill 2 (oldest due date); One payment (50\$) is created for Bill 1.
175	60	75	50	One payment (75\$) is created for Bill 2 (oldest due date); One payment (60\$) is created for Bill 1; The remaining amount (40\$) is applied on the On Account contract.
200	50	50	50	The entire amount (200\$) is applied on the On Account contract. This is because the payment amount is greater than the account's billed balance plus overpayment threshold amount.

If the identified customer has multiple accounts, then the payment is applied to the On Account contract. If there are no accounts for the identified customer, or account could not be found in ORMB, or the customer could not be found in ORMB, the payment is applied to the suspense contract defined on the tender source associated with the external source (lockbox) ID.

If the source system customer number is not available, but the invoice ID and MICR are available in the payment and remittance record, then batch uses the invoice ID to find the account for which the invoice is created. Once the account is identified, the system behaves in the similar manner (listed above) when the identified customer has one account.

If the source system customer number and invoice ID are not available, but the MICR is available in the payment and remittance record, then system finds the payment where the same MICR is stamped as a characteristic and then finds the account for which the respective payment is created. In this way, the system derives the account for which the payment must be applied. However, the MICR is used to derive the account only when the **Search Customer Using MICR (Y/**

**N**) parameter in the batch is set to **Y**. Once the account is derived, the system behaves in the similar manner (listed above) when the identified customer has one account.

You can upload payment and remittance advice in the TXT format. You need to ensure that the text file is in the required format; otherwise the file will not be uploaded.

Once the text file is uploaded through the **Lockbox Payment Upload - Small Group (C1-PUPSG)** batch, the deposit control staging, tender control staging, and payment upload staging records are created in the respective tables. You can then execute the **Payment Upload (PUPL)** batch to create the deposit control, tender controls, payment events, tenders, payments, and payment segments using payment records in the staging area.

**Note:** For more information about the batches, refer to the *Oracle Revenue Management and Billing Batch Guide*.

---

# Chapter 30

---

## Deferred Revenue Recognition

---

### Topics:

- [Prerequisites](#)
- [Deferred Revenue Recognition Status Transition](#)
- [Algorithms Used in Deferred Revenue Recognition](#)
- [Deferred Revenue Recognition Template \(Used for Searching\)](#)
- [Deferred Revenue Recognition Template \(Used for Viewing\)](#)
- [Deferred Revenue Recognition \(Used for Searching\)](#)
- [Deferred Revenue Recognition \(Used for Viewing\)](#)

Most often, insurance company bill policies in installments, but Accounts Receivable (AR) and revenue for the total premium are booked as new business in the beginning of the policy term. Regulations, restrictions, or company policies may require that revenue for the total premium must be initially booked to the general ledger as deferred revenue. As time passes, the deferred revenue is realized as earned revenue. For example, the total premium for six months auto-policy (July 1 to Dec 31) is \$1200. When this new business is booked, the revenue of \$1200 is initially booked as deferred revenue. However, on July 31, August 31, September 30, October 31, November 30, and December 31, \$200 must be transferred from deferred revenue GL to earned revenue GL. In order to manage this process, adjustments are created that transfer amount from deferred revenue GL to earned revenue GL.

A deferred revenue recognition schedule determines when these deferred revenue recognition adjustments must be created and posted. On the recognition date, the deferred revenue recognition adjustment is created to transfer a portion of deferred revenue to earned revenue. The corresponding financial transaction does not impact customer's account balance.

You need to create a deferred revenue recognition template for each distribution code and contract type combination for which you want to create a deferred revenue recognition (when the bill segment and adjustment financial transactions created against the respective contracts are frozen). It is the deferred revenue recognition template which helps the system to determine:

- Adjustment type using which the adjustment should be created when the deferred revenue is recognized
- Whether the recognition amount and date in the deferred revenue recognition schedule are editable until recognized
- Whether the deferred revenue recognition schedule must be generated automatically or manually
- Whether the deferred revenue must be recognized daily, weekly, or monthly
- Whether the deferred revenue amount must be prorated when the recognition schedule is set to Monthly
- Algorithm using which the recognition lines in the deferred revenue recognition schedule should be created
- Algorithm using which the adjustment must be generated when the deferred revenue is recognized

During the deferred revenue recognition process, a deferred revenue recognition creation goes through various statuses in its lifecycle. For more information

about the deferred revenue recognition statuses, see [Deferred Revenue Recognition Status Transition](#) on page 2177.

**Note:** The lifecycle of a deferred revenue recognition creation is driven by the respective business object using which the deferred revenue recognition is generated. The deferred revenue recognition feature explained in this document is articulated based on the lifecycle and logic defined in the business objects.

For more information on how to setup the deferred revenue recognition process, see [Prerequisites](#) on page 2177.



## Prerequisites

---

To setup the deferred revenue recognition feature, you need to do the following:

- Define the required deferred revenue recognition templates in the system.
- Define the required characteristic types where the characteristic entity is set to **Deferred Revenue Recognition**.
- Define the values for the following parameters in the **C1-REVRECITM** algorithm:
  - Use Calendar or Business Days (C or B)
  - Override Default Recognition Date (Y or N)
  - Override Default Weekly Recognition Day (Mon, Tue, Wed, Thu, Fri, Sat, Sun)
  - Override Default Monthly Recognition Date (1-31)
- Define the value for the **Use Contract Expiration Date (Y or N)** parameter in the **C1-REVRECSCH** algorithm.
- Define the value for the **Create Adjustments (Y or N)** parameter in the **C1-REVITMREC** algorithm.
- Set the batch control type of the **Deferred Revenue Recognition Periodic Monitor (C1-RRSMO)** batch to **Timed** and define the following attributes:
  - Time Interval
  - Timer Active
  - User ID
  - Batch Language
  - Email Address

## Deferred Revenue Recognition Status Transition

---

The following figure graphically indicates how a deferred revenue recognition status transition moves from one status to another:

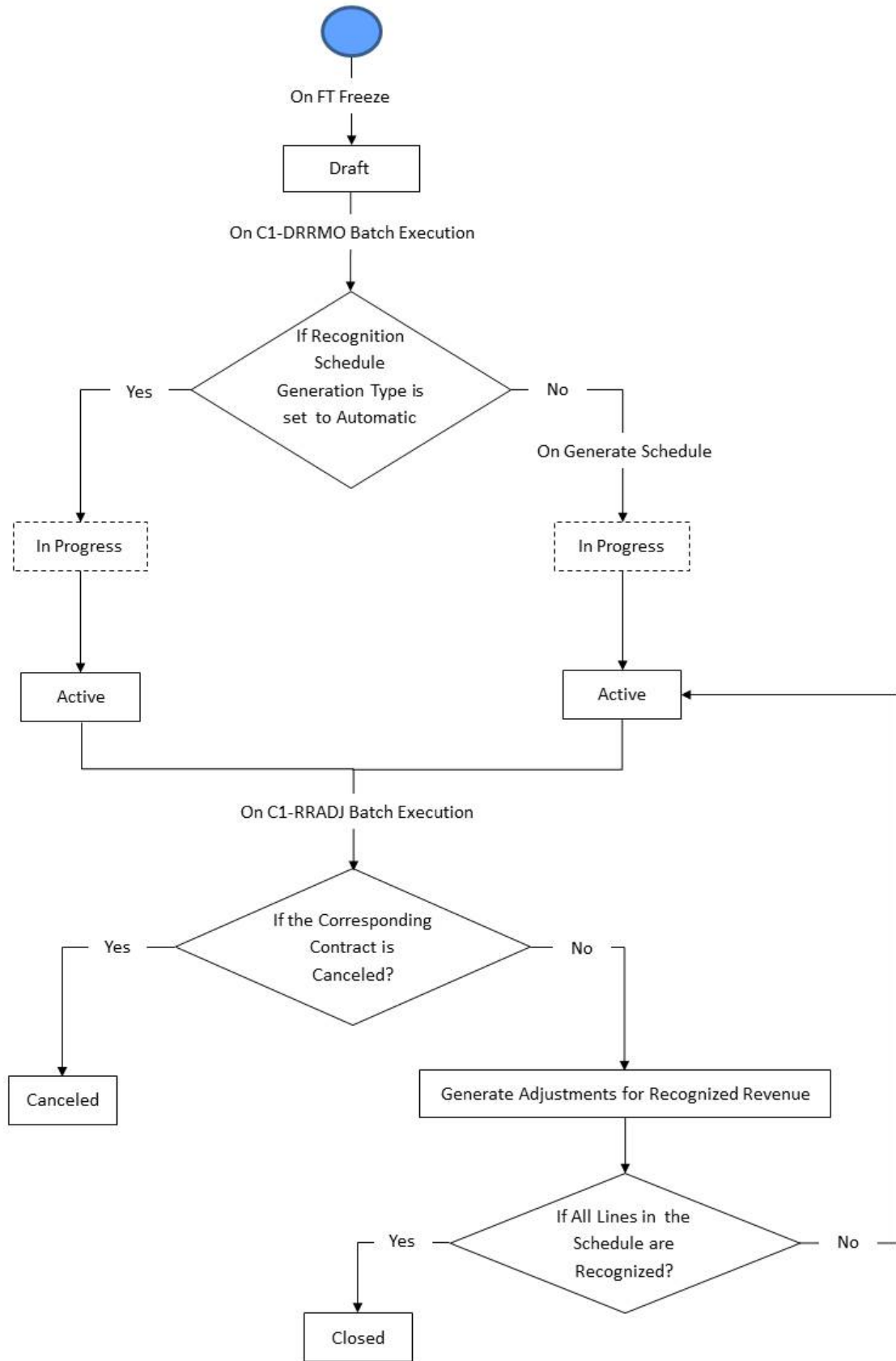

## Algorithms Used in Deferred Revenue Recognition

The following table lists the algorithms which are used in the lifecycle of the business object:

Status	System Event	Algorithm	Algorithm Type	Description
		C1-REVRECSCH	C1-REVRECSCH	<p>This algorithm is invoked when the status of the bill segment and adjustment financial transactions created against the contracts (of the contract type to which the algorithm is attached) is set to Frozen. It checks whether an active deferred revenue recognition template exists for the distribution code and contract type combination. If so, it creates a deferred revenue recognition using the template and sets the status of the deferred revenue recognition to Draft. It then checks whether the type of the corresponding financial transaction is Bill Segment or Adjustment. If the type of the corresponding financial transaction is Bill Segment, it sets the valid until date of the deferred revenue recognition to the bill segment end date. However, if the type of the corresponding financial transaction is Adjustment, it checks whether the Use Contract Expiration Date (Y or N) parameter is set to Y or N. If the Use Contract Expiration Date (Y or N) parameter is set to Y, it sets the valid until date of the deferred revenue recognition to the contract expiration date. However, if the Use Contract Expiration Date (Y or N) parameter is set to N, it sets the valid until date of the deferred revenue recognition to the financial transaction arrears date. In addition, on creating the deferred revenue recognition, an appropriate log entry is added which you can view in the Deferred Revenue Recognition Log zone. It contains the following parameter:</p> <ul style="list-style-type: none"> <li>• Use Contract Expiration Date (Y or N) – Used to indicate whether the valid until date must be set to the contract expiration date when the type of the corresponding financial transaction is Adjustment. The valid values are Y and N. This parameter is mandatory.</li> </ul>

Status	System Event	Algorithm	Algorithm Type	Description
		C1-REVRECITM	C1-REVRECITM	<p>This algorithm creates schedule for the deferred revenue recognition. It considers the valid until date and accordingly creates the recognition lines within the schedule. If the recognition schedule is Weekly, by default, the recognition day is set to Mon (which means Monday of each week). However, if the recognition schedule is Monthly, by default, the recognition date is set to the last day of the month (i.e. 28, 29, 30, or 31) It contains the following parameters:</p> <ul style="list-style-type: none"> <li>• <b>Use Calendar or Business Days (C or B)</b> - Used to indicate whether you want to use the calendar or business days while generating the recognition schedule. The business days are derived using the work calendar defined on the financial transaction. If you do not specify any value for this parameter, by default, it is set to C. This parameter is mandatory.</li> <li>• <b>Override Default Recognition Date (Y or N)</b> – Used to indicate whether you want to override the default weekly or monthly recognition date. The valid values are Y and N. This parameter is mandatory.</li> <li>• <b>Override Default Weekly Recognition Day (Mon, Tue, Wed, Thu, Fri, Sat, Sun)</b> – Used to indicate the day of the week when you want to recognize the deferred revenue. The valid values are Mon, Tue, Wed, Thu, Fri, Sat, and Sun. This parameter is required when you want to override the default weekly recognition day.</li> <li>• <b>Override Default Monthly Recognition Date (1-31)</b> - Used to indicate the day of the month when you want to recognize the deferred revenue. The valid values are 1, 2, 3, ..., 31. This parameter is required when you want to override the default monthly recognition date.</li> </ul>

Status	System Event	Algorithm	Algorithm Type	Description
		C1-REVRECADJ	C1-REVRECADJ	This algorithm creates deferred revenue recognition adjustment using the adjustment type defined on the respective deferred revenue recognition template. Before creating the deferred revenue recognition adjustment, it checks whether the contract for which the deferred revenue recognition is created is cancelled. If so, the status of the deferred revenue recognition is set to Canceled. If all lines in the recognition schedule are recognized, the status of the deferred revenue recognition is set to Closed.
		C1-REVITMREC	C1-REVITMREC	<p>If this algorithm is attached in the deferred revenue recognition template, it is invoked while executing the C1-RRADJ batch. It contains the following parameter:</p> <ul style="list-style-type: none"> <li>• <b>Create Adjustments (Y or N)</b> – Used to indicate whether the deferred revenue recognition adjustment must be created or not when the recognition date is earlier than or equal to the batch business date. The valid values are Y and N. This parameter is mandatory.</li> </ul>
		C1-DRRTM-INF	C1-DRRTM-INF	<p>This algorithm generates the deferred revenue recognition template information string which appears throughout the application. It concatenates the following fields separated by a comma in the specified order:</p> <ol style="list-style-type: none"> <li>1. Deferred Revenue Recognition Template</li> <li>2. Description</li> </ol>

Status	System Event	Algorithm	Algorithm Type	Description
		C1-DRRTMPVAL	C1-DRRTMPVAL	<p>This algorithm validates the deferred revenue recognition template. It checks the following:</p> <ul style="list-style-type: none"> <li>• Whether the data is specified in the mandatory fields, such as Deferred Revenue Recognition Template, Description, Status, Distribution Code, Contract Type, Adjustment Type, Recognition Schedule Generation Type, and Recognition Schedule.</li> <li>• Whether an algorithm is attached to the Create Deferred Revenue Recognition Schedule and Generate Deferred Revenue Recognition Adjustment system events.</li> <li>• Whether a deferred revenue recognition template already exists for the specified distribution code and contract type combination.</li> <li>• Whether special characters except underscore are specified in the Deferred Revenue Recognition Template field.</li> <li>• Whether the high proration limit is between 0 to 31 and is greater than the low proration limit.&gt;&gt; Whether the low proration limit is between 0 to 31 and is less than the high proration limit.</li> </ul> <p>In addition, it does not allow you to:</p> <ul style="list-style-type: none"> <li>• Delete a deferred revenue recognition template when it is used to create a deferred revenue recognition.</li> <li>• Edit a deferred revenue recognition template when the corresponding deferred revenue recognition is in the Draft status.</li> <li>• Inactivate a deferred revenue recognition template when the corresponding deferred revenue recognition is not in the Closed status.</li> </ul> <p>You must attach this validation algorithm to the custom business object which is used to create a deferred revenue recognition template. Otherwise, erroneous results might occur.</p>

Status	System Event	Algorithm	Algorithm Type	Description
		C1-DRRSC- INF	C1-DRRSC-INF	<p>This algorithm generates the deferred revenue recognition information string which appears throughout the application. It concatenates the following fields separated by a comma in the specified order:</p> <ol style="list-style-type: none"> <li>1. Deferred Revenue Recognition Template</li> <li>2. Deferred Revenue Recognition Status</li> <li>3. Distribution Code</li> <li>4. Deferred Revenue Recognition ID</li> </ol>
		C1-REVMON	C1-REVMON	<p>This algorithm is invoked when the C1-DRRMO batch is executed. It checks whether there are any deferred revenue recognitions in the Draft status. If there is any deferred revenue recognition in the Draft status, it checks whether the recognition schedule generation type in the respective deferred revenue recognition template is set to Automatic or Manual. If the recognition schedule generation type is set to Automatic, the status of the deferred revenue recognition is changed to In Progress. However, if the recognition schedule generation type is set to Manual, the status of the deferred revenue recognition remains as Draft.</p>
		C1- REVRECINP	C1-REVRECINP	<p>This algorithm creates an appropriate log entry when the status of the deferred revenue recognition is changed to In Progress. It invokes the algorithm attached to the Create Deferred Revenue Recognition Schedule system event of the respective deferred revenue recognition template. Once the recognition schedule is successfully created, the status of the deferred revenue recognition is changed to Active.</p>

Status	System Event	Algorithm	Algorithm Type	Description
		C1-REVRECACT	C1-REVRECACT	<p>This algorithm transitions the current status to the specified status. You can specify the status to which you want the business object to transition in the following parameters:</p> <ul style="list-style-type: none"> <li>• Next Status</li> <li>• Next Transition Condition</li> </ul> <p>At a time, you can specify value for either the <b>Next Status</b> or <b>Next Transition Condition</b> parameter. If you don't specify any value for these parameters, the system will transition the business object to the default next status specified in its lifecycle. This algorithm creates an appropriate log entry when the status of the deferred revenue recognition is changed to Active.</p>

## Deferred Revenue Recognition Template (Used for Searching)

The **Deferred Revenue Recognition** screen allows you to search for a deferred revenue recognition template using various search criteria. Through this screen, you can navigate to the following screen:

- [Deferred Revenue Recognition Template \(Used for Viewing\)](#) on page 2192

This screen consists of the following zone:

- [Search Deferred Revenue Recognition Template](#) on page 2184

## Search Deferred Revenue Recognition Template

The **Search Deferred Revenue Recognition Template** zone allows you to search for a deferred revenue recognition template using various search criteria. It contains the following two sections:

- **Search Criteria** – The **Search Criteria** section contains the following fields:

Field Name	Field Description	Mandatory (Yes or No)
Deferred Revenue Recognition Template	Used to search the basic information about the deferred revenue recognition template.	Yes
Description	Used to search the description of the deferred revenue recognition template.	No
Recognition Schedule	Used to search deferred revenue recognition with a particular schedule. The valid values are: <ul style="list-style-type: none"> <li>• Daily</li> <li>• Monthly</li> <li>• Weekly</li> </ul>	No



Field Name	Field Description	Mandatory (Yes or No)
Status	Used to indicate the deferred revenue recognition template with a particular status. The valid values are: <ul style="list-style-type: none"> <li>Active</li> <li>Inactive</li> </ul>	No

**Note:** You must specify at least one search criterion while searching for a deferred revenue recognition template.

- **Search Results** – On clicking the **Search** button, the search results appear based on the specified search criteria. The **Search Results** section contains the following columns:

Column Name	Column Description
Deferred Revenue Recognition Template	Displays the deferred revenue recognition. <div style="border: 1px solid black; padding: 5px; margin-top: 5px;"> <p><b>Note:</b> It has a link. On clicking the link, the <b>Deferred Revenue Recognition Template</b> screen appears where you can view the details of the respective deferred revenue recognition template.</p> </div>
Distribution Code	Indicates the distribution code associated with the rate component.
Contract Type	Displays the contract which is generated against a particular type of contract.
Recognition Schedule	Displays the schedule when the deferred revenue is recognized.

### Related Topics

For more information on...	See...
How to view the details of a deferred revenue recognition template	<a href="#">Viewing the Deferred Revenue Recognition Template Details</a> on page 2191
How to search for a deferred revenue recognition template	<a href="#">Searching for a Deferred Revenue Recognition Template</a> on page 2185

## Searching for a Deferred Revenue Recognition Template

### Prerequisites

To search for a deferred revenue recognition template, you should have:

- Deferred revenue recognition template defined in the system.
- Deferred Revenue Recognition Schedule defined in the system.

### Procedure

To search for a deferred revenue recognition template:

1. Click the **Admin** menu in the **Application** toolbar.  
A list appears.
2. From the **Admin** menu, select **D** and then click **Deferred Revenue Recognition Template**.  
The **Deferred Revenue Recognition Template** screen appears.
3. Enter the search criteria in the **Search Deferred Revenue Recognition Template** zone.

**Note:** ORMB search engine supports wildcard search, where you can substitute the percentage (%) symbol as a stand in for any word or letter in a search criteria. You can use the ‘%’ wildcard character in all input fields except the date and ID fields. The ‘%’ wildcard character is suffixed automatically at the end of the partial search criteria. Therefore, you may or may not specify the wildcard character at the end of the partial search criteria. However, you have to prefix the wildcard character manually wherever required.

#### 4. Click **Search**.

A list of deferred revenue recognition templates that meet the search criteria appears in the **Search Results** section.

#### Related Topics

For more information on...	See...
<b>Deferred Revenue Recognition Template</b> screen	<a href="#">Deferred Revenue Recognition Template (Used for Searching)</a> on page 2184
<b>Search Deferred Revenue Recognition Template</b> zone	<a href="#">Search Deferred Revenue Recognition Template</a> on page 2184

## Defining a Deferred Revenue Recognition Template

### Prerequisites

To define a deferred revenue recognition template, you should have:

- Contract types defined in the system

### Procedure

To define a deferred revenue recognition template:

1. Click the **Admin** menu in the **Application** toolbar.

A list appears.

2. From the **Admin** menu, select **D** and then click **Deferred Revenue Recognition Template**.

The **Deferred Revenue Recognition Template** screen appears.

3. Click the **Add** button in the **Page Title** area of the **Deferred Revenue Recognition Template** screen.

The **Deferred Revenue Recognition Template** screen appears. It contains the following sections:

- **Main** – Used to specify basic details about the deferred revenue recognition template.
- **Parameters** – Used to specify the various parameters for the deferred revenue recognition template.
- **Algorithms** – Used to associate algorithms with the deferred revenue recognition template.
- **Divisions** – Used to associate a deferred revenue recognition template with a division.
- **Characteristics** – Used to define characteristics for the deferred revenue recognition template.

The **Main** section contains the following fields:

Field Name	Field Description	Mandatory (Yes or No)
Deferred Revenue Recognition Template	Used to specify the deferred revenue recognition template.	Yes
Description	Used to specify the description of the deferred revenue recognition template.	No

Field Name	Field Description	Mandatory (Yes or No)
Status	Used to indicate the status of the deferred revenue recognition template. The valid values are: <ul style="list-style-type: none"> <li>Active</li> <li>Inactive</li> </ul>	Yes

The **Parameters** section contains the following fields:

Field Name	Field Description	Mandatory (Yes or No)
Distribution Code	Used to indicate the distribution code associated with the deferred revenue recognition.  <div style="border: 1px solid black; padding: 2px;"> <b>Note:</b> The <b>Search</b> (🔍) icon appears corresponding to this field. On clicking the <b>Search</b> icon, the <b>Distribution Code Search</b> window appears. </div>	Yes
Contract Type	Used to indicate a particular type of contract.  <div style="border: 1px solid black; padding: 2px;"> <b>Note:</b> The <b>Search</b> (🔍) icon appears corresponding to this field. On clicking the <b>Search</b> icon, the <b>Contract Type Search</b> window appears. </div>	Yes
Adjustment Type	Used to indicate the adjustment type using which the adjustment must be created.  <div style="border: 1px solid black; padding: 2px;"> <b>Note:</b> The <b>Search</b> (🔍) icon appears corresponding to this field. On clicking the <b>Search</b> icon, the <b>Adjustment Type Search</b> window appears. </div>	No
Allow Editing	Used to allow editing of recognition schedule.	No
Generation Type	Used to indicate the type of deferred revenue recognition generation. The valid values are: <ul style="list-style-type: none"> <li>Automatic</li> <li>Manual</li> </ul>	Yes (Conditional)
Recognition Schedule	Used to indicate the schedule of deferred revenue recognition generation. The valid values are: <ul style="list-style-type: none"> <li>Daily</li> <li>Monthly</li> <li>Weekly</li> </ul>	Yes
Allow Proration	Used to allow proration.  <div style="border: 1px solid black; padding: 2px;"> <b>Note:</b> The <b>Allow Proration</b> field appears only when you select <b>Recognition Schedule</b> as <b>Monthly</b>. </div>	Yes

Field Name	Field Description	Mandatory (Yes or No)
High Proration Limit (Days)	Used to specify whether deferred revenue amount must be prorated while revenue recognition. If the number of days from when the policy is enrolled to the end of the month (in which it is enrolled) is greater than the specified limit, then the amount is prorated.  <b>Note:</b> This field appears only when you check the tick-box for <b>Allow Proration</b> .	Yes (Conditional)  <b>Note:</b> This field is required only when the recognition schedule is selected as monthly and when the <b>Allow Proration</b> check box is selected.
Low Proration Limit (Days)	Used to specify whether deferred revenue amount must be prorated while revenue recognition. If the number of days from when the policy is enrolled to the end of the month (in which it is enrolled) is less than the specified limit, then the amount is prorated.  <b>Note:</b> This field appears only when you check the tick-box for <b>Allow Proration</b> .	Yes (Conditional)  <b>Note:</b> This field is required only when the recognition schedule is selected as monthly and when the <b>Allow Proration</b> check box is selected.

4. Enter the required details.
5. Associate algorithms with the deferred revenue recognition template, if required.
6. View the division to which the deferred revenue recognition template is associated in the **Divisions** section.
7. Define the characteristics specific to division to which the deferred revenue recognition template is associated in the **Characteristics** section.
8. Click **Save**.

The deferred revenue recognition template is created.

#### Related Topics

For more information on...	See...
<b>Deferred Revenue Recognition Template</b> screen	<a href="#">Deferred Revenue Recognition Template (Used for Searching)</a> on page 2184
How to associate algorithms with the deferred revenue recognition template	<a href="#">Associating Algorithms with a Deferred Revenue Recognition Template</a> on page 2188

## Associating Algorithms with a Deferred Revenue Recognition Template

### Procedure

To associate algorithms with a deferred revenue recognition template:

1. Ensure that the **Algorithms** section is expanded when you are defining or editing a deferred revenue recognition template.

The **Algorithms** section contains the following fields in a grid:

Field Name	Field Description	Mandatory (Yes or No)
System Event	Used to indicate the system event for an algorithm.	Yes

Field Name	Field Description	Mandatory (Yes or No)
Sequence	Used to specify the sequence number.  <b>Note:</b> On specifying the value for a predefined characteristic type, the description of the characteristic value appears corresponding to the <b>Characteristic Value</b> field.	Yes
Algorithm	Used to associate an algorithm to the system event that you have selected.  <b>Note:</b> The <b>Search</b>  icon appears corresponding to this field. On clicking the <b>Search</b> icon, the <b>Algorithm Search</b> window appears. On specifying the algorithm for a system event, the description of the algorithm appears corresponding to the <b>Algorithm</b> field.	Yes

- Enter the required details in the **Algorithms** section.
- If you want to define more than one algorithm for the deferred revenue recognition template, click the **Add**  icon, and then repeat 2.

**Note:** However, if you want to remove an algorithm from the deferred revenue recognition template, click the **Delete**  icon corresponding to the algorithm.

### Related Topics

For more information on...	See...
How to define a deferred revenue recognition template	<a href="#">Defining a Deferred Revenue Recognition Template</a> on page 2186
How to edit a deferred revenue recognition template	<a href="#">Editing a Deferred Revenue Recognition Template</a> on page 2194

## Associating Deferred Revenue Recognition Template With A Division

### Prerequisites

To associate deferred revenue recognition template with a division, you should have:

- Divisions defined in the application

### Procedure

To associate deferred revenue recognition template with a division:

- Ensure that the **Divisions** section is expanded when you are creating or editing a deferred revenue recognition template.

The **Divisions** section appears. It contains the following fields:

Field Name	Field Description	Mandatory (Yes or No)
Division	Used to indicate the division to which you want to associate the deferred revenue recognition template.  <b>Note:</b> You can only view those divisions to which you have access in the <b>Division</b> list.	No

- Select the required division from the list.
- If you want to associate the deferred revenue recognition template with more than one division, click the **Add** (+) icon and then repeat step 2.

**Note:** However, if you want to remove the deferred revenue recognition template from a division, click the **Delete** (🗑️) icon corresponding to the division.

- Click **Save**.

The deferred revenue recognition template is associated with the divisions.

### Related Topics

For more information on...	See...
How to edit a deferred revenue recognition template	<a href="#">Editing a Deferred Revenue Recognition Template</a> on page 2194
How to define a deferred revenue recognition template	<a href="#">Defining a Deferred Revenue Recognition Template</a> on page 2186

## Defining Characteristics for a Deferred Revenue Recognition Template

### Prerequisites

To define characteristics for a deferred revenue recognition template, you should have:

- Characteristic types defined in the application (where the characteristic entity is set to **Deferred Revenue Recognition Template**)

### Procedure

To define characteristics for a deferred revenue recognition template:

- Ensure that the **Characteristics** section is expanded when you are defining or editing a deferred revenue recognition template.

The **Characteristics** section contains the following fields in a grid:

Field Name	Field Description	Mandatory (Yes or No)
Characteristic Type	Used to indicate the characteristic type.	Yes (Conditional)  <b>Note:</b> This field is required when you are defining a characteristic for the deferred revenue recognition template.

Field Name	Field Description	Mandatory (Yes or No)
Characteristic Value	Used to specify the value for the characteristic type.  <b>Note:</b> On specifying the value for a characteristic type, the description of the characteristic value appears corresponding to the <b>Characteristic Valued</b> field.	Yes (Conditional)  <b>Note:</b> This field is required when you are defining a characteristic for the deferred revenue recognition template.

- Enter the required details in the **Characteristics** section.
- If you want to define more than one characteristic for the deferred revenue recognition template, click the **Add** (+) icon and then repeat step 2.

**Note:** However, if you want to remove a characteristic from the deferred revenue recognition template, click the **Delete** (🗑️) icon corresponding to the characteristic.

### Related Topics

For more information on...	See...
How to edit a deferred revenue recognition template	<a href="#">Editing a Deferred Revenue Recognition Template</a> on page 2194
How to define a deferred revenue recognition template	<a href="#">Defining a Deferred Revenue Recognition Template</a> on page 2186

## Viewing the Deferred Revenue Recognition Template Details

### Procedure

To view the details of a deferred revenue recognition template:

- Click the **Admin** link in the **Application** toolbar.  
A list appears.
- From the **Admin** menu, select **D** and then click **Deferred Revenue Recognition Template**.  
The **Deferred Revenue Recognition Template** screen appears.
- Search for the deferred revenue recognition template in the **Deferred Revenue Recognition Template** screen.
- In the **Search Results** section, click the link in the **Deferred Revenue Recognition Template** column corresponding to the deferred revenue recognition template whose details you want to view.  
The **Deferred Revenue Recognition Template** screen appears.
- View the details of the deferred revenue recognition template in the **Deferred Revenue Recognition Template** zone.

### Related Topics

For more information on...	See...
<b>Deferred Revenue Recognition Template</b> screen	<a href="#">Deferred Revenue Recognition Template (Used for Searching)</a> on page 2184
<b>Deferred Revenue Recognition Template</b> zone	<a href="#">Deferred Revenue Recognition Template</a> on page 2192
How to search for a deferred revenue recognition template	<a href="#">Searching for a Deferred Revenue Recognition Template</a> on page 2185

## Deferred Revenue Recognition Template (Used for Viewing)

Once the deferred revenue recognition templates are created, the **Deferred Revenue Recognition Template** screen allows you to:

- Generate the deferred revenue recognition schedule
- View the details of a deferred revenue recognition template
- Edit a deferred revenue recognition template
- Delete a deferred revenue recognition template

This screen consists of the following zone:

- [Deferred Revenue Recognition Template](#) on page 2192

### Deferred Revenue Recognition Template

The **Deferred Revenue Recognition Template** zone displays the details of the deferred revenue recognition template. It contains the following sections:

- **Main** – Displays basic information about the deferred revenue recognition template. It contains the following fields:

Field Name	Field Description
Deferred Revenue Recognition Template	Displays the deferred revenue recognition template
Description	Used to specify the description of the deferred revenue recognition template
Status	Used to indicate the status of the deferred revenue recognition template. The valid values are: <ul style="list-style-type: none"> <li>• Active</li> <li>• Inactive</li> </ul>

- **Parameters** – Displays the parameters used in the deferred revenue recognition template.

Field Name	Field Description
Distribution Code	Indicates the distribution code.  <b>Note:</b> It has a link. On clicking the link, the <b>Distribution Code</b> screen appears where you can view the details of the respective distribution code.
Contract Type	Displays the <b>Deferred Revenue Recognition Template</b> which are generated against a particular type of contract.
Adjustment Type	Indicates the adjustment type using which the adjustment must be created.  <b>Note:</b> It has a link. On clicking the link, the <b>Adjustment Type</b> screen appears where you can view the details of the respective adjustment type.



Field Name	Field Description
Generation Type	Displays the type of deferred revenue recognition template. The valid values are: <ul style="list-style-type: none"> <li>Manual</li> <li>Automatic</li> </ul>
Allow Editing	Indicates the editing of recognition schedule.
Recognition Schedule	Indicates the schedule when the deferred revenue is recognized. The valid values are: <ul style="list-style-type: none"> <li>Daily</li> <li>Monthly</li> <li>Weekly</li> </ul>
Allow Proration	Used to allow proration.  <div style="border: 1px solid black; padding: 5px;"><b>Note:</b> The <b>Allow Proration</b> field appears only when you select <b>Recognition Schedule</b> as <b>Monthly</b>.</div>
High Proration Limit (Days)	Displays whether deferred revenue amount must be prorated while revenue recognition. If the number of days from when the policy is enrolled to the end of the month (in which it is enrolled) is greater than the specified limit, then the amount is prorated.  <div style="border: 1px solid black; padding: 5px;"><b>Note:</b> This field appears only when you check the tick-box for <b>Allow Proration</b>.</div>
Low Proration Limit (Days)	Displays whether deferred revenue amount must be prorated while revenue recognition. If the number of days from when the policy is enrolled to the end of the month (in which it is enrolled) is less than the specified limit, then the amount is prorated.  <div style="border: 1px solid black; padding: 5px;"><b>Note:</b> This field appears only when you check the tick-box for <b>Allow Proration</b>.</div>

- **Divisions** – Displays the associated deferred revenue recognition template with one or more divisions. It contains the following column:

Column Name	Column Description
Division	Displays the division to which you want to associate the deferred revenue recognition template.

- **Algorithms** – Lists the algorithms associated with the deferred revenue recognition template. It contains the following columns:

Column Name	Column Description	Mandatory (Yes or No)
System Event	Indicates the system event on which the algorithm must be executed	No
Sequence	Displays the sequence number.	No

Column Name	Column Description	Mandatory (Yes or No)
Algorithm	Displays an algorithm that needs to be attached to the selected system event.  <b>Note:</b> It has a link. On clicking the link, the <b>Algorithm</b> screen appears where you can view the details of the respective algorithm.	No

- **Characteristics** – Lists the characteristics defined for the deferred revenue recognition template. It contains the following fields:

Column Name	Column Description
Characteristic Type	Displays the characteristic type.
Characteristic Type	Displays the value of the characteristic type.

- **Record Actions** – This section contains the following buttons:

Button Name	Button Description
Edit	Used to define, edit, and remove algorithms of the deferred revenue recognition template.  <b>Note:</b> The <b>Edit</b> button appears only when the deferred revenue recognition template is in the <b>Active</b> status.
Delete	Used to delete the deferred revenue recognition template.

- 
- **Record Information** – This section contains the following fields:

Field Name	Field Description
Business Object	Indicates the business object using which the deferred revenue recognition template is created. In addition, a context menu appears corresponding to this field which helps in navigating to other screens in the application.  <b>Note:</b> It has a link. On clicking the link, the <b>Business Object</b> screen appears where you can view the details of the respective business object.

## Editing a Deferred Revenue Recognition Template

### Procedure

To edit a deferred revenue recognition template:

1. Search for the deferred revenue recognition template in the **Deferred Revenue Recognition Template** screen.
2. In the **Search Results** section, click the link in the **Deferred Revenue Recognition Template** column corresponding to the deferred revenue recognition template whose details you want to edit.

The **Deferred Revenue Recognition Template** screen appears.

3. Click the **Edit** button in the **Deferred Revenue Recognition Template** zone.

The **Deferred Revenue Recognition Template** screen appears.

**Note:** The **Edit** button appears only when the deferred revenue recognition template is in the **Active** status.

4. Associate, edit, or remove algorithms from the deferred revenue recognition template, if required.
5. Define, edit, or remove characteristics from the deferred revenue recognition template, if required.
6. Associate deferred revenue recognition template with a division, if required.
7. Click **Save**.

The changes made to the deferred revenue recognition template are saved.

### **Related Topics**

<b>For more information on...</b>	<b>See...</b>
<b>Deferred Revenue Recognition Template</b> screen	<a href="#">Deferred Revenue Recognition Template (Used for Viewing)</a> on page 2192
<b>Deferred Revenue Recognition Template</b> zone	<a href="#">Deferred Revenue Recognition Template</a> on page 2192
How to search for a deferred revenue recognition template	<a href="#">Searching for a Deferred Revenue Recognition Template</a> on page 2185
How to associate algorithms with a deferred revenue recognition template	<a href="#">Associating Algorithms with a Deferred Revenue Recognition Template</a> on page 2188

## **Deleting a Deferred Revenue Recognition Template**

### **Procedure**

To delete a deferred revenue recognition template:

1. Search for the deferred revenue recognition template in the **Deferred Revenue Recognition Template** screen.
2. In the **Search Results** section, click the link in the **Deferred Revenue Recognition Template** column corresponding to the deferred revenue recognition template that you want to delete.

The **Deferred Revenue Recognition Template** screen appears.

3. Click the **Delete** button in the **Deferred Revenue Recognition Template** zone.

A message appears confirming whether you want to delete the deferred revenue recognition template.

4. Click **OK**.

The deferred revenue recognition template is deleted.

### **Related Topics**

<b>For more information on...</b>	<b>See...</b>
<b>Deferred Revenue Recognition Template</b> screen	<a href="#">Deferred Revenue Recognition Template (Used for Viewing)</a> on page 2192
<b>Deferred Revenue Recognition Template</b> zone	<a href="#">Deferred Revenue Recognition Template</a> on page 2192
How to search for a deferred revenue recognition template	<a href="#">Searching for a Deferred Revenue Recognition Template</a> on page 2185

## **Viewing the Deferred Revenue Recognition Template Details**

### **Procedure**

To view the details of a deferred revenue recognition template:

1. Click the **Admin** link in the **Application** toolbar.  
A list appears.
2. From the **Admin** menu, select **D** and then click **Deferred Revenue Recognition Template**.  
The **Deferred Revenue Recognition Template** screen appears.
3. Search for the deferred revenue recognition template in the **Deferred Revenue Recognition Template** screen.
4. In the **Search Results** section, click the link in the **Deferred Revenue Recognition Template** column corresponding to the deferred revenue recognition template whose details you want to view.  
The **Deferred Revenue Recognition Template** screen appears.
5. View the details of the deferred revenue recognition template in the **Deferred Revenue Recognition Template** zone.

### Related Topics

For more information on...	See...
<b>Deferred Revenue Recognition Template</b> screen	<a href="#">Deferred Revenue Recognition Template (Used for Searching)</a> on page 2184
<b>Deferred Revenue Recognition Template</b> zone	<a href="#">Deferred Revenue Recognition Template</a> on page 2192
How to search for a deferred revenue recognition template	<a href="#">Searching for a Deferred Revenue Recognition Template</a> on page 2185

## Deferred Revenue Recognition (Used for Searching)

The **Deferred Revenue Recognition** screen allows you to search for a deferred revenue recognition using various search criteria. Through this screen, you can navigate to the following screen:

- [Deferred Revenue Recognition \(Used for Viewing\)](#) on page 2202

This screen consists of the following zone:

- [Search Deferred Revenue Recognition](#) on page 2196

## Search Deferred Revenue Recognition

The **Search Deferred Revenue Recognition** zone allows you to search for a deferred revenue recognition using various search criteria. It contains the following two sections:

- **Search Criteria** – This section contains the following fields:

Field Name	Field Description	Mandatory (Yes or No)
Search By	<p>Used to indicate whether you want to search for a deferred revenue recognition using the deferred revenue recognition, person, account, or policy details. The valid values are:</p> <ul style="list-style-type: none"> <li>• Account Details</li> <li>• Person Details</li> <li>• Deferred Revenue Recognition Details</li> <li>• Financial Transaction Details</li> <li>• Policy Details</li> </ul> <p><b>Note:</b> By default, the <b>Account Details</b> option is selected.</p>	Yes
Person ID	<p>Used to search deferred revenue recognition which are assigned to a particular person.</p> <p><b>Note:</b> This field appears only when you select the <b>Person Details</b> option from the <b>Search By</b> list.</p>	No
Account ID	<p>Used to search the account ID.</p> <p><b>Note:</b> This field appears only when you select the <b>Account Details</b> option from the <b>Search By</b> list.</p>	No
Person Identifier Type	<p>Used to select the identifier type based on which you want to search deferred revenue recognition through which the person's record is created or updated in the system.</p>	<p>Yes (Conditional)</p> <p><b>Note:</b> If you specify the person identifier as a search criteria, you have to select the person identifier type.</p>
Person Identifier	<p>Used to specify the value for the person identifier type.</p>	<p>Yes (Conditional)</p> <p><b>Note:</b> If you specify the person identifier type as a search criteria, you have to specify the person identifier.</p>
Account Identifier Type	<p>Used to specify the account identifier type of the account whose details you want to search.</p> <p><b>Note:</b> This field appears only when you select the <b>Account Details</b> option from the <b>Search By</b> list.</p>	<p>Yes (Conditional)</p> <p><b>Note:</b> If you specify the account identifier as a search criteria, you have to select the account identifier type.</p>

Field Name	Field Description	Mandatory (Yes or No)
Account Identifier	Used to specify the value of the account identifier.  <b>Note:</b> This field appears only when you select the <b>Account Details</b> option from the <b>Search By</b> list.	Yes (Conditional)  <b>Note:</b> If you specify the account identifier type as a search criteria, you have to specify the account identifier.
Contract ID	Used to specify the contract ID linked to the account.  <b>Note:</b> This field appears only when you select the <b>Account Details</b> option from the <b>Search By</b> list.	No
Person Hierarchy	Used to indicate whether to display hierarchy of the person linked to a particular bill.  <b>Note:</b> This field appears only when you select the <b>Person Details</b> option from the <b>Search By</b> list.	No
Status	Used to search deferred revenue recognition with a particular status. The valid values are:  <ul style="list-style-type: none"> <li>• Active</li> <li>• Closed</li> <li>• Canceled</li> <li>• Draft</li> </ul> <b>Note:</b> This field appears only when you select the <b>Person Details</b> , <b>Account Details</b> , or <b>Deferred Revenue Recognition Details</b> option from the <b>Search By</b> list.	No
Deferred Revenue Recognition Template	Used to indicate the template used for deferred revenue recognition.  <b>Note:</b> This field appears only when you select the <b>Person Details</b> , <b>Account Details</b> , or <b>Deferred Revenue Recognition Details</b> option from the <b>Search By</b> list.	No
Valid Until Date	Used to specify the date till which the deferred revenue recognition is valid.  <b>Note:</b> This field appears only when you select the <b>Person Details</b> or <b>Account Details</b> option from the <b>Search By</b> list.	No

Field Name	Field Description	Mandatory (Yes or No)
Deferred Revenue Recognition ID	Used to search a particular deferred revenue recognition  <b>Note:</b> This field appears only when you select the <b>Deferred Revenue Recognition Details</b> option from the <b>Search By</b> list.	No
Description	Used to specify the description of the deferred revenue recognition.  <b>Note:</b> This field appears only when you select the <b>Deferred Revenue Recognition Details</b> option from the <b>Search By</b> list.	No
Recognition Schedule	Used to search deferred revenue recognition with a particular schedule. The valid values are: <ul style="list-style-type: none"> <li>• Daily</li> <li>• Monthly</li> <li>• Weekly</li> </ul> <b>Note:</b> This field appears only when you select the <b>Deferred Revenue Recognition Details</b> option from the <b>Search By</b> list.	No
Financial Transaction ID	Used to search deferred revenue recognition which are assigned to a particular financial transaction.  <b>Note:</b> This field appears only when you select the <b>Financial Transaction Details</b> option from the <b>Search By</b> list.	
Policy Type	Used to indicate the type of policy.  <b>Note:</b> This field appears only when you select the <b>Policy Details</b> option from the <b>Search By</b> list.	Yes
Policy Number	Used to indicate the policy number.  <b>Note:</b> This field appears only when you select the <b>Policy Details</b> option from the <b>Search By</b> list.	No
Plan Number	Used to indicate the plan number of the policy.  <b>Note:</b> This field appears only when you select the <b>Policy Details</b> option from the <b>Search By</b> list.	No
Source System	Used to indicate the name of the external system from where the policy originated.  <b>Note:</b> This field appears only when you select the <b>Policy Details</b> option from the <b>Search By</b> list.	No

Field Name	Field Description	Mandatory (Yes or No)
Start Date	Used to indicate the date from when the policy is effective.  <b>Note:</b> This field appears only when you select the <b>Policy Details</b> option from the <b>Search By</b> list.	No
End Date	Used to indicate the date till when the policy is effective.  <b>Note:</b> This field appears only when you select the <b>Policy Details</b> option from the <b>Search By</b> list.	No

**Note:** You must specify at least one search criterion while searching for a deferred revenue recognition.

- **Search Results** – On clicking the **Search** button, the search results appear based on the specified search criteria. The **Search Results** section contains the following columns:

Column Name	Column Description
Deferred Revenue Recognition Information	Displays information about the deferred revenue recognition.  <b>Note:</b> It has a link. On clicking the link, the <b>Deferred Revenue Recognition</b> screen appears where you can view the details of the respective deferred revenue recognition.
Contract Information	Displays the basic information about the contract corresponding to the deferred revenue recognition. In addition, this column has a context menu which helps in navigating to other screens in the application.  <b>Note:</b> It has a link. On clicking the link, the <b>Contract</b> screen appears where you can view the details of the respective contract.
Financial Transaction Information	Displays the basic information about the financial transaction corresponding to the deferred revenue recognition.  <b>Note:</b> It has a link. On clicking the link, the <b>Financial Transaction</b> screen appears where you can view the details of the respective financial transaction.

### Related Topics

For more information on...	See...
How to view the details of a deferred revenue recognition	<a href="#">Viewing the Deferred Revenue Recognition Details</a> on page 2201
How to search for a deferred revenue recognition	<a href="#">Searching for a Deferred Revenue Recognition</a> on page 2200

## Searching for a Deferred Revenue Recognition

### Prerequisites

To search for a deferred revenue recognition, you should have:

- Deferred Revenue Recognition Template defined in the application.



- Person identifier types defined in the application
- Account identifier types defined in the application
- Recognition Schedules defined in the application
- Source Systems defined in the application

### **Procedure**

To search for a deferred revenue recognition:

1. Click the **Menu** link in the **Application** toolbar.  
A list appears.
2. From the **Main** menu, select **Deferred Revenue Recognition**.  
A sub-menu appears.
3. Click the **Search** option from the **Deferred Revenue Recognition** sub-menu.  
The **Deferred Revenue Recognition** screen appears.
4. Enter the search criteria in the **Search Deferred Revenue Recognition** zone.

**Note:** ORMB search engine supports wildcard search, where you can substitute the percentage (%) symbol as a stand in for any word or letter in a search criteria. You can use the ‘%’ wildcard character in all input fields except the date and ID fields. The ‘%’ wildcard character is suffixed automatically at the end of the partial search criteria. Therefore, you may or may not specify the wildcard character at the end of the partial search criteria. However, you have to prefix the wildcard character manually wherever required.

5. Click **Search**.

A list of deferred revenue recognition that meet the search criteria appears in the **Search Results** section.

### **Related Topics**

<b>For more information on...</b>	<b>See...</b>
<b>Deferred Revenue Recognition</b> screen	<a href="#">Deferred Revenue Recognition (Used for Searching)</a> on page 2196
<b>Search Deferred Revenue Recognition</b> zone	<a href="#">Search Deferred Revenue Recognition</a> on page 2196

## **Viewing the Deferred Revenue Recognition Details**

### **Procedure**

To view the details of a deferred revenue recognition:

1. Search for the deferred revenue recognition in the **Deferred Revenue Recognition** screen.
2. In the **Search Results** section, click the link in the **Deferred Revenue Recognition Information** column corresponding to the deferred revenue recognition whose details you want to view.

The **Deferred Revenue Recognition** screen appears. It consists of the following tabs:

- [Deferred Revenue Recognition - Main](#) on page 2202
  - [Deferred Revenue Recognition - Log](#) on page 2205
3. Ensure that the **Main** tab is selected.
  4. View the details of the deferred revenue recognition in the **Deferred Revenue Recognition** zone.

### **Related Topics**

For more information on...	See...
<b>Deferred Revenue Recognition</b> screen	<a href="#">Deferred Revenue Recognition (Used for Viewing)</a> on page 2202
<b>Search Deferred Revenue Recognition</b> zone	<a href="#">Search Deferred Revenue Recognition</a> on page 2196
How to search for a deferred revenue recognition	<a href="#">Searching for a Deferred Revenue Recognition</a> on page 2200

## Deferred Revenue Recognition (Used for Viewing)

The **Deferred Revenue Recognition** screen allows you to:

- View the details of a deferred revenue recognition
- Edit a deferred revenue recognition
- Generate the deferred revenue recognition schedule
- Add related deferred revenue recognitions
- Edit the details of a deferred revenue recognition schedule
- View the log of a deferred revenue recognition
- Add a log entry for a deferred revenue recognition

This screen consists of the following tabs:

- [Deferred Revenue Recognition - Main](#) on page 2202
- [Deferred Revenue Recognition - Log](#) on page 2205

### Deferred Revenue Recognition - Main

The **Main** tab displays information about the deferred revenue recognition. It contains the following zones:

- [Deferred Revenue Recognition](#) on page 2202
- [Associated Deferred Revenue Recognitions](#) on page 2204
- [Recognition Schedule](#) on page 2205
- [Revenue Recognition Items](#) on page 2205

### Deferred Revenue Recognition

The **Deferred Revenue Recognition** zone displays the details of the deferred revenue recognition. It contains the following sections:

- **Main** – Displays basic information about the deferred revenue recognition. It contains the following fields:

Field Name	Field Description
Deferred Revenue Recognition Information	Displays information about the deferred revenue recognition.
Deferred Revenue Recognition Template Information	Displays information about the deferred revenue recognition template. <b>Note:</b> It has a link. On clicking the link, the <b>Deferred Revenue Recognition Template</b> screen appears where you can view the details of the deferred revenue recognition template.
Distribution Code	Displays the distribution code which indicates the template associated with the deferred revenue recognition.

Field Name	Field Description
Financial Transaction Information	<p>Displays the basic information about the financial transaction corresponding to the deferred revenue recognition.</p> <p><b>Note:</b> It has a link. On clicking the link, the <b>Financial Transaction Information</b> screen appears where you can view the details of the financial transaction.</p>
Total Revenue Deferred	Displays the total revenue deferred.
Total Revenue Recognized	Displays the total revenue recognized.
Status	<p>Indicates the status of the deferred revenue recognition. The valid values are:</p> <ul style="list-style-type: none"> <li>• Active</li> <li>• Closed</li> <li>• Canceled</li> <li>• Draft</li> </ul>

- **Related Deferred Revenue Recognitions** - Lists the related deferred revenue recognitions. It contains the following columns:

Column Name	Column Description
Deferred Revenue Recognition Information	Displays the basic information of the related Deferred Revenue Recognition Schedules (i.e. DRR Schedule of the BS/AD, corresponding to the BX/AX)
Create Date Time	Displays the date and time when the deferred revenue recognition is created.
Financial Transaction Information	Displays the basic information about the financial transaction corresponding to the deferred revenue recognition.

- **Record Actions** – This section contains the following buttons:

Button Name	Button Description
Edit	<p>Used to define, edit and remove characteristics, related deferred revenue recognitions of the deferred revenue recognition.</p> <p><b>Note:</b> The <b>Edit</b> button appears only when the deferred revenue recognition is in the <b>Active</b> status.</p>
Generate Schedule	<p>Used to generate the deferred revenue recognition schedule.</p> <p><b>Note:</b> The <b>Generate Schedule</b> button appears only when the deferred revenue recognition is in the <b>Draft</b> status.</p>

- **Record Information** – This section contains the following fields:

Field Name	Field Description
Business Object	Indicates the business object using which the deferred revenue recognition is created. In addition, a context menu appears corresponding to this field which helps in navigating to other screens in the application.  <b>Note:</b> It has a link. On clicking the link, the <b>Business Object</b> screen appears where you can view the details of the respective business object.
Create Date/Time	Displays the date and time when the deferred revenue recognition schedule is created.
Status Date/Time	Displays the date and time when the deferred revenue recognition status is updated.

- **Characteristics** – Lists the characteristics defined for the deferred revenue recognition. It contains the following columns:

Column Name	Column Description
Effective Date	Displays the date from when the characteristic is effective for the deferred revenue recognition.
Characteristic Type	Indicates the characteristic type.
Characteristic Value	Displays the value of the characteristic type.

### Associated Deferred Revenue Recognitions

The **Associated Deferred Revenue Recognitions** zone Displays the basic information of the other schedules linked to the same **FT** having a separate **Schedule** due to the different **Distribution Code**. Purpose of this section is to show all the associated **Schedules** generated for a single **FT**. It contains the following columns:

Column Name	Column Description
Deferred Revenue Recognition Information	Displays information about the deferred revenue recognition.  <b>Note:</b> It has a link. On clicking the link, the <b>Deferred Revenue Recognition</b> screen appears where you can view the details of the deferred revenue recognition.
Financial Transaction Information	Displays the basic information about the financial transaction corresponding to the deferred revenue recognition.  <b>Note:</b> It has a link. On clicking the link, the <b>Financial Transaction</b> screen appears where you can view the details of the respective deferred revenue recognition.
Distribution Code	Displays the distribution code which indicates the template associated with the deferred revenue recognitions.
Deferred Revenue Recognition Template Information	Displays information about the deferred revenue recognition template.  <b>Note:</b> It has a link. On clicking the link, the <b>Deferred Revenue Recognition Template</b> screen appears where you can view the details of the deferred revenue recognition template.

Column Name	Column Description
Status	Indicates the status of the associated deferred revenue recognition. The valid values are: <ul style="list-style-type: none"> <li>Active</li> <li>Closed</li> <li>Canceled</li> </ul>

### Recognition Schedule

The **Recognition Schedule** zone lists the adjustment information and the recognition amount of the deferred revenue recognition. It contains the following columns:

Column Name	Column Description
Recognition Date	Displays the date on which the recognition is scheduled.
Recognition Amount	Displays the amount of the recognition scheduled.
Adjustment Information	Displays information about the adjustments in recognition schedule.

This zone contains the **Edit** button. It is used to edit the details of recognition schedule

**Note:** This zone appears when the deferred revenue recognition is in the **Active** status.

### Revenue Recognition Items

The **Revenue Recognition Items** zone displays the adjustment information about the recognition items. It contains the following columns:

Column Name	Column Description
Recognition Date	Displays the date on which the recognition is scheduled.
Recognition Amount	Displays the amount of the recognition scheduled.
Adjustment Information	Displays information about the adjustments in recognition schedule. “ <div data-bbox="537 1283 1474 1367" style="border: 1px solid black; padding: 5px; margin-top: 5px;"> <p><b>Note:</b> It has a link. On clicking the link, the <b>Adjustment</b> screen appears where you can view the details of the deferred revenue recognition.</p> </div>

## Deferred Revenue Recognition - Log

The **Log** tab contains the following zone:

- [Deferred Revenue Recognition Log](#) on page 2205

### Deferred Revenue Recognition Log

The **Deferred Revenue Recognition Log** zone lists the complete trail of actions performed on the deferred revenue recognition. It contains the following columns:

Column Name	Column Description
Date/Time	Displays the date and time when the action was performed on the deferred revenue recognition
Details	Displays the details about the action performed on the deferred revenue recognition
User	Indicates the user who has performed the action on the deferred revenue recognition

Column Name	Column Description
Log Type	Indicates the type of log.
Related Object	Indicates the object or entity which is created when the action is performed on the deferred revenue recognition.  <b>Note:</b> At present, no data appears in this column. The implementation team can build the custom logic to meet the business requirements.
Status Reason	Indicates the reason why the status of the deferred revenue recognition is changed.  <b>Note:</b> At present, no data appears in this column. The implementation team can build the custom logic to meet the business requirements.

**Note:** You can manually add a log entry for the deferred revenue recognition by clicking the **Add Log Entry** link in the upper right corner of the **Deferred Revenue Recognition Log** zone.

### Related Topics

For more information on...	See...
How to view the log of a deferred revenue recognition	<a href="#">Viewing the Log of a Deferred Revenue Recognition</a> on page 2210
How to add a log entry for a deferred revenue recognition	<a href="#">Adding a Log Entry for a Deferred Revenue Recognition</a> on page 2211

## Editing a Deferred Revenue Recognition

### Procedure

To edit a deferred revenue recognition:

1. Search for the deferred revenue recognition in the **Deferred Revenue Recognition** screen.
2. In the **Search Results** section, click the link in the **Deferred Revenue Recognition Information** column \orresponding to the deferred revenue recognition whose details you wa  
The **Deferred Revenue Recognition** screen appears.
3. Click the **Edit** button in the **Deferred Revenue Recognition** zone.  
The **Deferred Revenue Recognition** screen appears.

**Note:** The **Edit** button appears only when the deferred revenue recognition is in the **Active** status.

4. Modify the required details in the **Main** section.
5. Define, edit, or remove related deferred revenue recognitions from the deferred revenue recognition, if required.
6. Define, edit, or remove characteristics from the deferred revenue recognition, if required.
7. Click **Save**.

The changes made to the deferred revenue recognition are saved.

### Related Topics

For more information on...	See...
<b>Deferred Revenue Recognition</b> screen	<a href="#">Deferred Revenue Recognition (Used for Viewing)</a> on page 2202

For more information on...	See...
<b>Deferred Revenue Recognition</b> zone	<a href="#">Deferred Revenue Recognition</a> on page 2202
How to search for a deferred revenue recognition	<a href="#">Searching for a Deferred Revenue Recognition</a> on page 2200
How to add related deferred revenue recognitions	<a href="#">Adding Related Deferred Revenue Recognitions</a> on page 2208
How to define the characteristics for a deferred revenue recognition	<a href="#">Defining Characteristics for a Deferred Revenue Recognition</a> on page 2207

## Creating the Deferred Revenue Recognition Schedule

### Prerequisites

To create the deferred revenue recognition schedule, you should have:

- Should have **Revenue Recognition Schedule Creation Algorithm** attached in the **DRR Template**

### Procedure

To create the deferred revenue recognition schedule:

1. Search for the deferred revenue recognition in the **Deferred Revenue Recognition** screen.
2. In the **Search Results** section, click the link in the **Deferred Revenue Recognition Information** column corresponding to the deferred revenue recognition whose recognition schedule you want to generate.

The **Deferred Revenue Recognition** screen appears.

3. Click the **Generate Schedule** button in the **Deferred Revenue Recognition** zone.

**Note:** The **Generate Schedule** button appears only when the deferred revenue recognition is in the **Draft** status.

The status of the deferred revenue recognition is changed to **Active**.

### Related Topics

For more information on...	See...
<b>Deferred Revenue Recognition</b> screen	<a href="#">Deferred Revenue Recognition (Used for Viewing)</a> on page 2202
<b>Deferred Revenue Recognition</b> zone	<a href="#">Deferred Revenue Recognition</a> on page 2202
How to search for a deferred revenue recognition	<a href="#">Searching for a Deferred Revenue Recognition</a> on page 2200

## Defining Characteristics for a Deferred Revenue Recognition

### Prerequisites

To define characteristics for a deferred revenue recognition, you should have:

- Characteristic types defined in the application (where the characteristic entity is set to **Deferred Revenue Recognition**)

### Procedure

To define characteristics for a deferred revenue recognition:

1. Ensure that the **Characteristics** section is expanded when you are editing a deferred revenue recognition.

The **Characteristics** section contains the following fields in a grid:

Field Name	Field Description	Mandatory (Yes or No)
Effective Date	Used to specify the date from when the characteristic is effective for the deferred revenue recognition.	Yes (Conditional) <b>Note:</b> This field is required when you are defining a characteristic for the deferred revenue recognition.
Characteristic Type	Used to indicate the characteristic type. <b>Note:</b> The list includes only those characteristic types where the characteristic entity is set to <b>Deferred Revenue Recognition</b> .	Yes (Conditional) <b>Note:</b> This field is required when you are defining a characteristic for the deferred revenue recognition.
Characteristic Value	Used to specify the value for the characteristic type. <b>Note:</b> On specifying the value for a characteristic type, the description of the characteristic value appears corresponding to the <b>Characteristic Value</b> field.	Yes (Conditional) <b>Note:</b> This field is required when you are defining a characteristic for the deferred revenue recognition.

- Enter the required details in the **Characteristics** section.

**Note:** If you select a characteristic type, the **Search**  icon appears corresponding to the **Characteristic Value** field. On clicking the **Search** icon, you can search for a characteristic value.

- If you want to define more than one characteristic for the deferred revenue recognition, click the **Add**  icon and then repeat step 2.

**Note:** However, if you want to remove a characteristic from the deferred revenue recognition, click the **Delete**  icon corresponding to the characteristic.

### Related Topics

For more information on...	See...
How to edit a deferred revenue recognition	<a href="#">Editing a Deferred Revenue Recognition</a> on page 2206

## Adding Related Deferred Revenue Recognitions

### Prerequisites

To add related deferred revenue recognitions, you should have:

- Deferred revenue recognition template defined in the system.

### Procedure

To add related deferred revenue recognitions:

- Ensure that the **Related Deferred Revenue Recognitions** section is expanded when you are editing a deferred revenue recognition.

The **Related Deferred Revenue Recognitions** section contains the following fields:



Field Name	Field Description	Mandatory (Yes or No)
Deferred Revenue Recognition ID	Used to specify the ID of the deferred revenue recognition.  <b>Note:</b> The <b>Search</b> (🔍) icon appears corresponding to this field. On clicking the <b>Search</b> icon, the <b>Deferred Revenue Recognition Search</b> window appears.	Yes
Create Date Time	Used to indicate the creation date and time of the deferred revenue recognition.	Yes
Financial Transaction ID	Used to specify the ID of the financial transaction corresponding to the deferred revenue recognition.  <b>Note:</b> The <b>Search</b> (🔍) icon appears corresponding to this field. On clicking the <b>Search</b> icon, the <b>Financial Transactions Search</b> window appears.	Yes

- Enter the required details in the **Related Deferred Revenue Recognitions** section.
- If you want to add more than one related deferred revenue recognition for the deferred revenue recognition, click the **Add** (+) icon and then repeat step 2.

**Note:** However, if you want to remove a related deferred revenue recognition from the deferred revenue recognition, click the **Delete** (🗑) icon corresponding to the related deferred revenue recognition.

### Related Topics

For more information on...	See...
How to edit a deferred revenue recognition	<a href="#">Editing a Deferred Revenue Recognition</a> on page 2206

## Editing the Deferred Revenue Recognition Schedule Details

### Prerequisites

To edit the details of the deferred revenue recognition schedule, you should have:

- Should have **Allow Editing Switch** as **Yes** on deferred revenue recognition template.

### Procedure

To edit the details of the deferred revenue recognition schedule:

- Search for the deferred revenue recognition in the **Deferred Revenue Recognition** screen.
- In the **Search Results** section, click the link in the **Deferred Revenue Recognition Information** column corresponding to the deferred revenue recognition whose deferred revenue recognition schedule details you want to edit.

The **Deferred Revenue Recognition** screen appears.

- Select the recognition whose details you want to edit in the **Recognition Schedule** zone and click the **Edit** button available in the upper left corner above the table in this zone.

The **Edit Recognition Schedule** screen appears.

**Note:** A recognition schedule from the deferred revenue recognition can be edited only when the deferred revenue recognition is in the **Active** status.

The **Edit Recognition Schedule** screen contains the following fields:

Field Name	Field Description
Deferred Revenue Recognition Information	Displays the information about the deferred revenue recognition.
Financial Transaction Information	Displays the information of the financial transaction corresponding to the deferred revenue recognition.

In addition to these fields, this screen contains following columns:

Column Name	Column Description	Mandatory (Yes or No)
Recognition Date	Used to display the date on which the deferred revenue is recognized.	Yes
Recognition Amount	Used to display the amount of the deferred revenue.	Yes
Adjustment ID	Used to display the adjustment id.	Not applicable

- Modify the details of the recognition schedule.
- If you want to define more than one recognition schedule for the deferred revenue recognition, click the **Add (+)** icon and then repeat step 4.

**Note:** However, if you want to remove a recognition schedule from the deferred revenue recognition, click the **Delete (🗑)** icon corresponding to the recognition schedule.

- Click **Save**.

The changes made to the recognition schedule are saved.

### **Related Topics**

For more information on...	See...
<b>Recognition Schedule</b> zone	<a href="#">Recognition Schedule</a> on page 2205
How to search for a deferred revenue recognition	<a href="#">Searching for a Deferred Revenue Recognition</a> on page 2200

## **Viewing the Log of a Deferred Revenue Recognition**

### **Procedure**

To view the log of a deferred revenue recognition:

- Search for the deferred revenue recognition in the **Deferred Revenue Recognition** screen.
- In the **Search Results** section, click the link in the **Deferred Revenue Recognition Information** column corresponding to the deferred revenue recognition whose log you want to view.

The **Deferred Revenue Recognition** screen appears. It consists of the following tabs:

- [Deferred Revenue Recognition - Main](#) on page 2202
- [Deferred Revenue Recognition - Log](#) on page 2205

- Click the **Log** tab.

The **Log** tab appears.

- View the complete trail of actions performed on the deferred revenue recognition in the **Deferred Revenue Recognition Log** zone.

Column Name	Column Description
Date/Time	Displays the date and time when the action was performed on the dispute request.
Details	Displays the details about the deferred revenue recognition log
User	Indicates the user who has performed deferred revenue recognition
Log Type	Indicates the type of log.
Related Object	Indicates the object or entity which is generated when the action is performed on the deferred revenue recognition
Status Reason	Displays the status reason of action performed on the deferred revenue recognition

### Related Topics

For more information on...	See...
<b>Deferred Revenue Recognition Log</b> zone	<a href="#">Deferred Revenue Recognition Log</a> on page 2205
How to search for a deferred revenue recognition	<a href="#">Searching for a Deferred Revenue Recognition</a> on page 2200
How to add a log entry for a deferred revenue recognition	<a href="#">Adding a Log Entry for a Deferred Revenue Recognition</a> on page 2211

## Adding a Log Entry for a Deferred Revenue Recognition

### Procedure

To add a log entry for a deferred revenue recognition:

- Search for the deferred revenue recognition in the **Deferred Revenue Recognition** screen.
- In the **Search Results** section, click the link in the **Deferred Revenue Recognition Information** column corresponding to the deferred revenue recognition whose log you want to edit.

The **Deferred Revenue Recognition** screen appears. It consists of the following tabs:.

- [Deferred Revenue Recognition - Main](#) on page 2202
- [Deferred Revenue Recognition - Log](#) on page 2205

- Click the **Log** tab.

The **Log** tab appears.

- Click on the **Add Log Entry** link in the upper right corner of the **Deferred Revenue Recognition Log** zone.

The **Add Deferred Revenue Recognition Schedule Log** window appears. It contains the following fields:

Field Name	Field Description	Mandatory (Yes Or No)
Deferred Revenue Recognition Information	Displays information about the deferred revenue recognition.	Not applicable
Log Details	Used to specify additional comments on the deferred revenue recognition.	Yes

- Enter the comments in the **Log Details** field.

**6. Click Save.**

The log entry is added in the **Deferred Revenue Recognition Log** zone.

**Related Topics**

<b>For more information on...</b>	<b>See...</b>
<b>Deferred Revenue Recognition Log</b> zone	<i><a href="#">Deferred Revenue Recognition Log</a></i> on page 2205
How to search for a deferred revenue recognition	<i><a href="#">Searching for a Deferred Revenue Recognition</a></i> on page 2200

---

# Chapter 31

---

## Reconciliation

---

### Topics:

- [Reconciliation Status Transition](#)
- [Pay Instruction Status Transition](#)
- [Discrepancy Report Status Transition](#)
- [EDI 820 File Format For Reconciliation](#)
- [Sample EDI 820 File Format](#)
- [Algorithms Used in C1-MemberReconType](#)
- [Algorithms Used in C1-MemberReconciliation](#)
- [Algorithms Used in C1-PayInstruction](#)
- [Algorithms Used in C1-MemberDiscReportType](#)
- [Algorithms Used in C1-DiscrepancyReport](#)
- [Reconciliation Type](#)
- [Reconciliation \(Used for Searching\)](#)
- [Reconciliation \(Used for Viewing\)](#)
- [Pay Instruction](#)
- [Discrepancy Report Type](#)
- [Discrepancy Report \(Used for Searching\)](#)
- [Discrepancy Report \(Used for Viewing\)](#)

Oracle Revenue Management and Billing enables you to reconcile pay instructions received from the external system against the bill segments based on the account identifier, policy number, plan number, member identifier, and coverage period combination. The system enables you to upload a pay instruction file in the following formats:

- CSV File Format – You can upload pay instruction files in the CSV format from the specified location on the server using the **Pay Instruction CSV File Upload (C1-RECUP)** batch.
- EDI 820 File Format – You can upload pay instruction files in the EDI 820 file format from the specified location on the server using the **Upload Lockbox Payment and Pay Instruction Files (C1-PUPSG)** batch.

**Note:** The **BPR** tag in the EDI 820 file must be set to **I** to indicate that the file contains pay instructions for reconciliation.

While uploading pay instruction files, you need to specify the reconciliation type using which you want to create the reconciliation. A reconciliation type indicates the algorithm which validates the pay instruction file and creates a pay instruction for each record in the file. Two algorithm types named **C1-PAYINSUPL** and **C1-RECONPROC** are shipped with the product. You need to maintain separate reconciliation types for different file formats. If you want to use a reconciliation type while uploading a pay instruction file in the CSV format, you need to create an algorithm using the **C1-PAYINSUPL** algorithm type and attach it to the reconciliation type. However, if you want to use a reconciliation type while uploading a pay instruction file in the EDI 820 format, you need to create an algorithm using the **C1-RECONPROC** algorithm type and attach it to the reconciliation type.

Once a file is successfully validated, the reconciliation is created for the file in the **Draft** status. The reconciliation is immediately transitioned to the **Send Notification** status and the algorithms attached to the Send Notification status are executed. Once the To Do is created, the status of the reconciliation is changed to **Pending**. A pay instruction is created for each record in the file and its status is set to either **Pending** or **Error** depending on whether it is successfully validated or not.

You need to then specify the payment ID against which you want to reconcile the billed items for which you have received the pay instructions. Once you specify the payment information and submit the pay instructions for reconciliation, the payment amount is distributed against the reconciliation contract of the accounts for which you have received the pay instruction. The status of the reconciliation is changed to **Pending Reconciliation**.

On reconciling the pay instructions, the system finds the bill segment against which the pay instruction must be reconciled using the account identifier, policy

number, plan number, member identifier, and coverage period combination. Once the bill segment is identified, the transfer adjustment is created against the bill segment and offset adjustment is created against the respective reconciliation contract. If all pay instructions in the file are successfully reconciled, the status of the reconciliation is changed to **Completed**. However, if one or more pay instruction in the file could not be successfully reconciled, the status of the reconciliation is changed to **Open**. If a file contains a pay instruction for previous coverage period, then system checks whether there is any open pay instruction for that coverage period in the system and accordingly tries to reconcile the pay instruction. However, if an open pay instruction for that coverage period does not exist in the system, the system tries to reconcile the pay instruction against the billed item.

You may manually reconcile the pay instructions which are in the **Pending Reconciliation** status. Alternatively, you can execute the **Reconciliation Periodic Monitor (C1-RCNM)** batch at regular interval to reconcile the pay instructions.

During reconciliation, a pay instruction also goes through various statuses in its lifecycle. You may configure the following two batches to execute at the regular intervals:

- **Pay Instruction Periodic Monitor (for Pending Status) (C1-PIPMO)** – It monitors whether there are any pay instructions in the **Pending** status. If so, it tries to reconcile the pay instruction against a billed item. If the pay instruction is successfully reconciled, the status of the pay instruction is changed to **Completed**. However, if the pay instruction could not be reconciled, the status of the pay instruction is changed to **Open**.
- **Pay Instruction Periodic Monitor (for Open Status) (C1-PIMDF)** – It monitors whether there are any pay instructions in the **Open** status. If so, it tries to reconcile the pay instruction against a billed item. If the pay instruction is successfully reconciled, the status of the pay instruction is changed to **Completed**. However, if the pay instruction could not be reconciled, the status of the pay instruction is changed to **Open**.

If you cancel the payment tender, the payment and reconciliation associated with the payment are automatically canceled. The status of the reconciliation is changed to **Pending Cancellation**. And, the status of all pay instructions in the reconciliation is changed to **Canceled**. If required, you can manually cancel a reconciliation. However, you can cancel a reconciliation only when it is in the **Open** or **Completed** status. On canceling a reconciliation, the status of the reconciliation is changed to **Pending Cancellation** and the status of all pay instructions in the reconciliation is changed to **Canceled**.

You need to configure the **Reconciliation Cancellation Periodic Monitor (C1-RCNMD)** batch to execute at the regular intervals. It monitors whether there are reconciliations in the **Pending Cancellation** status. If there is a reconciliation in the **Pending Cancellation** status, the status of the reconciliation is changed to **Canceled**.

The system enables you to create a copy of reconciliation when it is in the **Canceled** status. If the number of pay instructions in the reconciliation does not exceed the value specified in the **Defer Processing Count** option type of the **C1-RECDUPBH** feature configuration, a copy of the reconciliation and pay instructions is created in the real time (i.e. immediately). The status of the reconciliation is set to **Pending**. And, the status of the pay instruction is set to either **Pending** or **Error** depending on whether it is successfully validated or not.

However, if the number of pay instructions in the reconciliation exceeds the value specified in the **Defer Processing Count** option type of the **C1-RECDUPBH** feature configuration, a batch job is automatically created using the **Duplicate Reconciliation (C1-RECUD)** batch. A message appears indicating the batch job ID. This batch job creates a copy of the reconciliation and pay instructions. The status of the reconciliation is set to **Pending**. And, the status of the pay instruction is set to either **Pending** or **Error** depending on whether it is successfully validated or not.

If the policy number, plan number, and member identifier are specified in a pay instruction, then the pay instruction is reconciled at the main subscriber level. If the policy number and plan number are specified in a pay instruction, then the pay instruction is reconciled at the plan level. However, if the policy number is only specified in a pay instruction, then the pay instruction is reconciled at the policy level.

On reconciling, some pay instructions are fully reconciled against the bill segments, some pay instructions are partially reconciled against the bill segments, and some pay instructions are not reconciled against any bill segments. The system enables you to capture such discrepancies for the reporting purposes. If required, you can generate the discrepancy report at the file or account level. If you generate the discrepancy report at the file level, the system lists the following:

- All pay instructions in the file which were partially reconciled due to rate variance
- All pay instructions in the file which could not be reconciled as the amount was paid, but not yet billed

However, if you generate the discrepancy report at the account level, the system lists the following:

- All billed items which were partially reconciled against pay instructions due to rate variance
- All billed items which could not be reconciled as the amount was billed, but not yet paid
- All pay instructions for the account which could not be reconciled as the amount was paid, but not yet billed

While generating a discrepancy report, you need to specify the discrepancy report type using which you want to create the discrepancy report. Once you review and finalize the discrepancy report, its status is changed to **Completed**. At a time, you can only have one discrepancy report for the file or account in the **Pending** status. Until, you finalize a discrepancy report, you cannot create another discrepancy report for the file or account. Also, note that you can create a discrepancy report for a file only when its corresponding reconciliation is in the **Open** status.

The reconciliation process goes through various statuses in its entire lifecycle. For more information about the reconciliation statuses, see...

- [Reconciliation Status Transition](#) on page 2216
- [Pay Instruction Status Transition](#) on page 2217
- [Discrepancy Report Status Transition](#) on page 2219

## Reconciliation Status Transition

The following figure graphically indicates how a reconciliation goes through various statuses in its lifecycle:

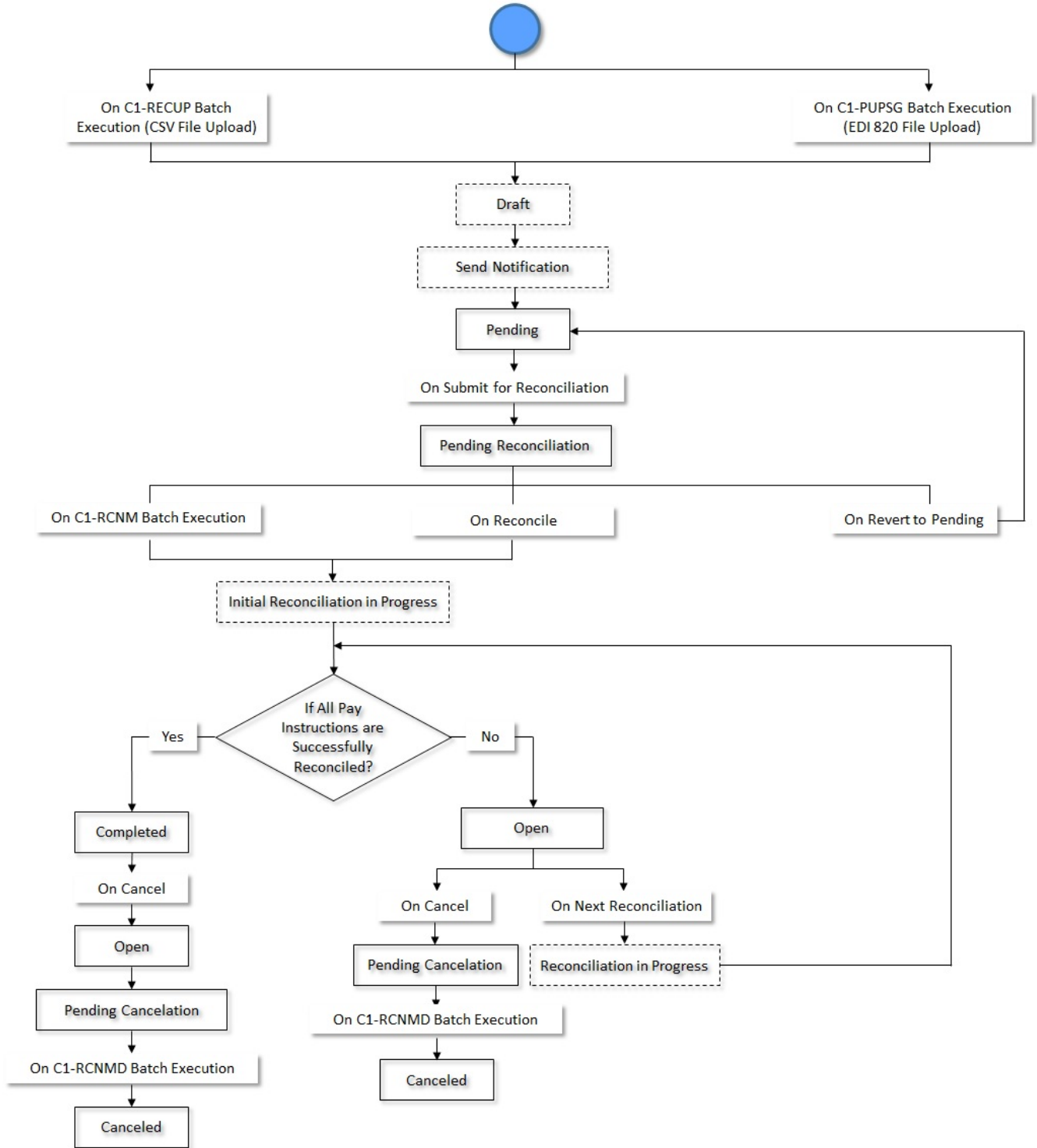



## Pay Instruction Status Transition

---

The following figure graphically indicates how a pay instruction goes through various statuses in its lifecycle:

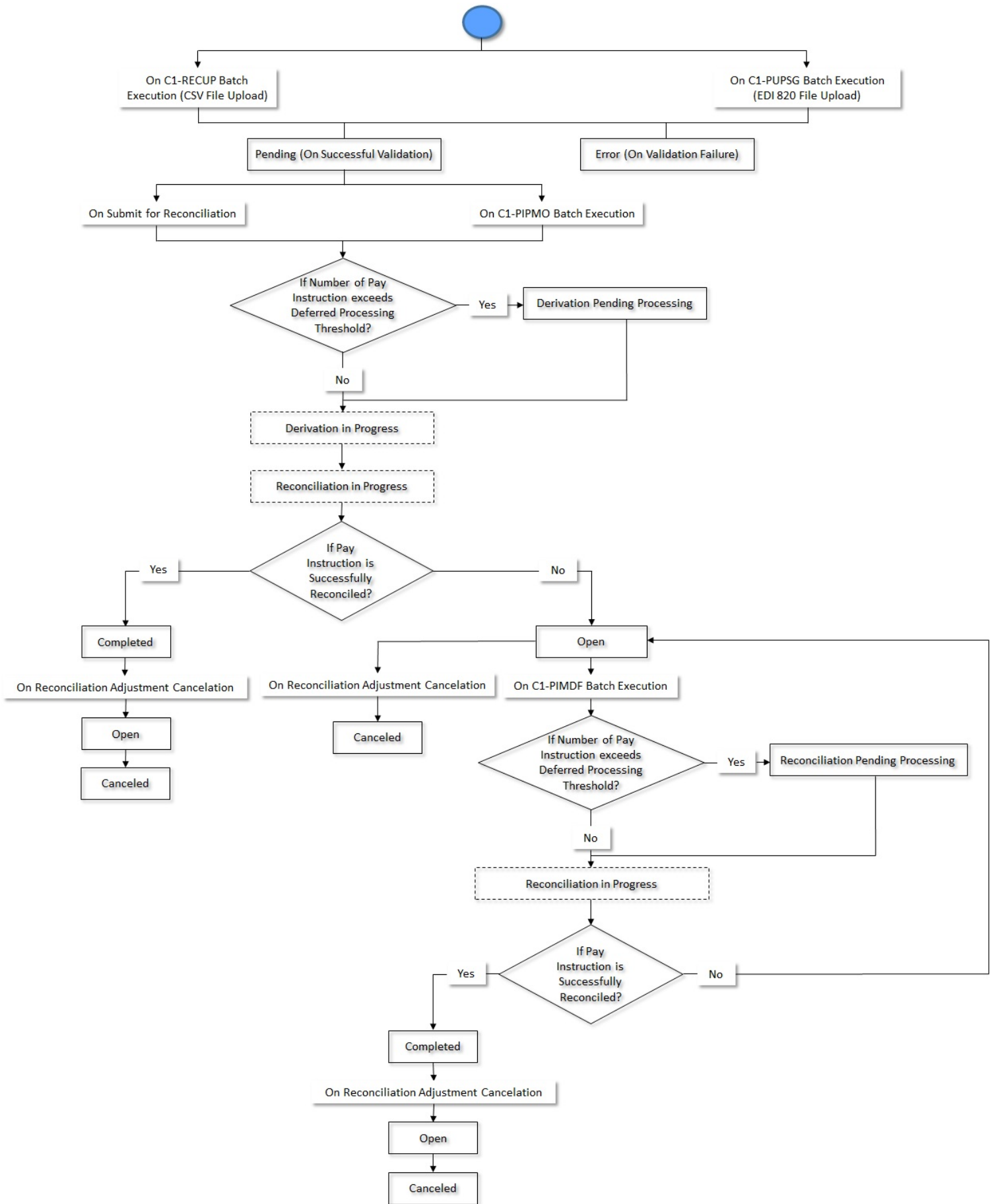

## Discrepancy Report Status Transition

The following figure graphically indicates how a Discrepancy Report goes through various statuses in its lifecycle:

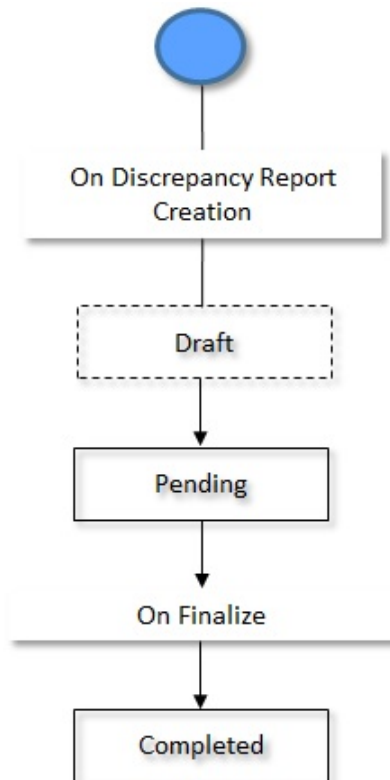

## EDI 820 File Format For Reconciliation

Before uploading an EDI 820 file, you need to ensure that the EDI 820 file contains the following columns:

Tag	Attribute	Description	Mandatory (Yes or No)
Algo Param	Account Identifier Type	Used to specify the account identifier type. The valid values are: <ul style="list-style-type: none"> <li>Account Name</li> <li>Base Global Account ID</li> <li>Bill Group Identifier</li> <li>Demo Bank Account Number</li> <li>External Account Identifier</li> <li>Flexcube Account ID</li> <li>International Bank Account Number</li> </ul>	Yes (Conditional)  <div style="border: 1px solid black; padding: 2px;"> <b>Note:</b> This data is required when Account Identifier is provided.         </div>

Tag	Attribute	Description	Mandatory (Yes or No)
N1[3]	Account Identifier value	Used to specify the value of the account identifier type.	Yes (Conditional) <b>Note:</b> This data is required when Account Identifier Type is provided.
Batch Param	Member Identifier type	Used to specify the member identifier type.	Yes
RMR[2]	Policy Number	Used to specify the policy number of the member.	Yes
Algo Param	Plan Number	Used to specify the plan number of the member.	No
ENT[4]	Member Identifier Value	Used to specify the value of the member identifier type.	Yes
RMR[4]	Amount	Used to specify the amount that has to be paid to the member.	Yes <b>Note:</b> The data value of this column must be 0, if no amount is provided.
DTM[6]	Coverage Start Date	Used to specify the date of the policy from where the coverage starts. <b>Note:</b> The Coverage Start Date cannot be later than the coverage end date.	Yes
DTM[6]	Coverage End Date	Used to specify the date of the policy till when the coverage ends. <b>Note:</b> The coverage end date cannot be earlier than the coverage start date.	Yes
NM1[4] [5]	Member Name	Used to specify the name of the member.	Yes
REF[2]	Plan Number	Used to specify the plan number of the member.	Yes (Conditional) <b>Note:</b> This data is required when Algo Param tag does not have a value.
Batch Param	Reconciliation Type	Used to specify the type of reconciliation.	Yes
Batch Param	Reconciliation Cancel Status	Used to specify the Reconciliation Cancellation status.	Yes

## Sample EDI 820 File Format

```
ISA*00**00**ZZ*USBANK*ZZ*UHGI*091212*1013*U*00401*000000005*0*P*~
GS*RA*LBTEST01*UHGI*20120912*1013*4*X*004010~
```

ST\*CHK\*000000001~  
 BPR\*I\*100\*C\*NON\*\*\*\*\*1581282972\*\*\*\*\*20130326~  
 DTM\*582\*\*\*\*RD8\*20170101-20171231~  
 N1\*PE\*\*FI\*vinodwReconTest534~  
 ENT\*1\*2J\*EI\*vinodwReconTest534~  
 NM1\*QE\*1\*\*vinodwReconTest534\*\*\*\*N\*11254331870~  
 RMR\*AZ\*12345\*\*0~  
 DTM\*582\*\*\*\*RD8\*20170401-20170430~  
 ENT\*1\*2J\*EI\*vinodwReconTest534~  
 NM1\*QE\*1\*\*vinodwReconTest534\*\*\*\*N\*11254331870~  
 RMR\*AZ\*12345\*\*0~  
 DTM\*582\*\*\*\*RD8\*20170501-20170531~  
 ENT\*1\*2J\*EI\*vinodwReconTest534~  
 NM1\*QE\*1\*\*vinodwReconTest534\*\*\*\*N\*11254331870~  
 RMR\*AZ\*12345\*\*0~  
 DTM\*582\*\*\*\*RD8\*20170601-20170630~  
 SE\*1\*000000001~  
 GE\*1\*135260~  
 IEA\*1\*505043666~

Here the tags ISA and IEA resemble Bank Details, whereas LBTEST01 indicates Tender Source information.

Tags like GS and GE, ST and SE are known as Start and End Tags. All of the other tags are embedded inside these Start and End tags.

For more information about the EDI 820 file format, see topic [EDI 820 File Format For Reconciliation](#) on page 2219

## Algorithms Used in C1-MemberReconType

The following table lists the algorithms which are attached to the **C1-MemberReconType** business object:

System Event	Algorithm	Algorithm Type	Description
Pre-Processing	C1-REOCNPEP	C1-REOCNPEP	Refer to <a href="#">C1-REOCNPEP</a> on page 2221

### C1-REOCNPEP

This algorithm validates a reconciliation type.

It checks the following:

- A duplicate algorithm is not added.
- A duplicate characteristic type is not added.

In addition, it does not allow you to:

- Delete a reconciliation type when the corresponding reconciliation is in a status other than **Completed** or **Canceled**.

## Algorithms Used in C1-MemberReconciliation

The following table lists the algorithms which are attached to the **C1-MemberReconciliation** business object:

System Event	Algorithm	Algorithm Type	Description
Information	C1-RECONINFO	C1-RECONINFO	Refer to <a href="#">C1-RECONINFO</a> on page 2223
Validation	C1-MRECONVAL	C1-MRECONVAL	Refer to <a href="#">C1-MRECONVAL</a> on page 2223

The following table lists the algorithms which are used in the lifecycle of the **C1-MemberReconciliation** business object:

Status	System Event	Algorithm	Algorithm Type	Description
Draft	-	-	-	-
Send Notification	Monitor	F1-AT-RQJ	F1-GEN-BOMNJ	Refer to <a href="#">F1-AT-RQJ</a> on page 1257
Send Notification	Enter	C1-RCNCRETD	F1-TDCREATE	Refer to <a href="#">F1-TDCREATE</a> on page 2223
Pending	Enter	C1-VALPAYINS	C1-VALPAYINS	Refer to <a href="#">C1-VALPAYINS</a> on page 2224
Pending	Exit	F1-TODOCOMPL	F1-TODOCOMPL	Refer to <a href="#">F1-TODOCOMPL</a> on page 1256
Pending Reconciliation	Monitor	F1-AT-RQJ	F1-GEN-BOMNJ	Refer to <a href="#">F1-AT-RQJ</a> on page 1257
Pending Reconciliation	Exit	C1-RECONVAL	C1-RECONVAL	Refer to <a href="#">C1-MRECONVAL</a> on page 2223
Initial Reconciliation In Progress	Monitor	C1-MONPAYINS	C1-MONPAYINS	Refer to <a href="#">C1-MONPAYINS</a> on page 2225
Initial Reconciliation In Progress	Enter	C1-TRNPAYRCN	C1-TRNPAYRCN	Refer to <a href="#">C1-TRNPAYRCN</a> on page 2225
Initial Reconciliation In Progress	Enter	C1-RCOPNPYIN	C1-RCOPNPYIN	Refer to <a href="#">C1-RCOPNPYIN</a> on page 2226
Initial Reconciliation In Progress	Exit	C1-RCNOPNMR	C1-RCNOPNMR	Refer to <a href="#">C1-RCNOPNMR</a> on page 2226
Open	-	-	-	-
Reconciliation Progress	In Monitor	C1-MONPAYINS	C1-MONPAYINS	Refer to <a href="#">C1-MONPAYINS</a> on page 2225
Reconciliation Progress	In Exit	C1-RCOPNPYIN	C1-RCOPNPYIN	Refer to <a href="#">C1-RCOPNPYIN</a> on page 2226
Completed	-	-	-	-

Status	System Event	Algorithm	Algorithm Type	Description
Pending Cancellation	Monitor	C1-RCMONPNCN	C1-GNBOMNRSN	Refer to <a href="#">C1-RCMONPNCN</a> on page 2226
Cancelled	Enter	C1-CANPAYINS	C1-CANPAYINS	Refer to <a href="#">C1-CANPAYINS</a> on page 2227
Cancelled	Enter	C1-CANRCNPAY	C1-CANRCNPAY	Refer to <a href="#">C1-CANRCNPAY</a> on page 2227
Cancelled	Enter	C1-RCNCANLTD	F1-TDCREATE	Refer to <a href="#">C1-RCNCANLTD</a> on page 2227

## C1-RECONINFO

This algorithm generates the reconciliation information string which appears throughout the application. It concatenates the following fields separated by a comma in the specified order:

- Reconciliation Type Description
- Reconciliation Status
- Reconciliation ID

## C1-MRECONVAL

This algorithm is invoked when you submit the pay instruction file for reconciliation. It checks the following:

- The payment is not associated with any other reconciliation which is in the status other than **Pending Cancellation** or **Canceled**.
- The payment ID and payor account ID are both available for further processing.

It contains the following parameters:

- **Reconciliation Canceled Status** – Used to specify the status code to which the reconciliation in the **Pending Cancellation** status is transitioned when the **Reconciliation Cancellation Periodic Monitor (C1-RCNMD)** batch is executed.
- **Reconciliation Pending Cancellation Status** - Used to specify the status code to which the reconciliation is transitioned when you click the **Cancel** button.

Both these parameters are mandatory.

## F1-AT-RQJ

This algorithm transitions the current status of the business object to the specified status. It contains the following parameters:

- **Next Status** – Used when you want to override the default next status specified in the lifecycle.
- **Next Transition Condition** – Used when you want to override the default next transition condition specified in the lifecycle.

At a time, you can specify value for either the **Next Status** or **Next Transition Condition** parameter. If you don't specify any value for these parameters, the system will transition the business object to the default next status specified in its lifecycle.

## F1-TDCREATE

This algorithm is invoked when the status of the reconciliation is changed to **Send Notification**. It creates a To Do using the specified To Do type and assigns it to users with the specified To Do role.

It contains the following parameters:

- **To Do Type** – Used to specify the type of notification that you want to generate when the reconciliation is created for a pay instruction file.
- **To Do Role** – Used to specify the To Do role to indicate the users to whom you want to send the notification when the reconciliation is created for a pay instruction file.

The rest of the parameters, such as **To Do Type Element Name**, **To Do Role Element Name**, **Message Category**, **Message Number**, **Characteristic Type For Log Entry**, **To Do Sort Keys Retriever Script**, **Discard Cancel Terminate Reason Element**, **Discard Cancel Terminate Reason**, **Retry Frequency**, and **Retry Frequency Element Name**, are not used at the moment.

## C1-VALPAYINS

This algorithm is invoked when the status of the reconciliation is changed to **Pending**. Once a pay instruction is created, this algorithm validates the following:

- The coverage end date is not earlier than the coverage start date.
- Either the account identifier type and account identifier or the account ID is available in the pay instruction record.
- The member identifier type is available when the member identifier is specified and vice versa.
- A person with the given member identifier type and member identifier combination exists in the system.
- An account with the specified account ID exists in the system.
- The account ID is derived using the account identifier type and account identifier combination when the account ID is not available in the pay instruction record.
- The account is eligible for reconciliation.

If the above mentioned validations are successful, the status of the pay instruction is set to **Pending**. However, if any of the above validation fails, the status of the pay instruction is set to **Error**.

This algorithm contains the following parameters:

- **Eligible for Reconciliation Characteristic Type** – Used to specify the characteristic type which indicates whether the account is eligible for reconciliation. This type of characteristic is defined on the account. You must specify a characteristic type where the characteristic entity is set to Account.
- **Maintenance Object for Generating Pay Instruction Logs** – Used to specify the maintenance object using which you want to generate logs for the pay instruction.
- **Pay Instruction Error Status** – Used to specify the status code to which you want to transition the pay instruction when the validation fails.
- **Pay Instruction Pending Status** – Used to specify the status code to which you want to transition the pay instruction when the validation is successful.

All these parameters are mandatory.

## F1-TODOCOMPL

This algorithm completes To Do entries that are created for the business object when the business object exits the given status. It finds and completes all open To Do entries where the business object's primary key is defined as a drill key. However, if the **Exclude To Do Entries From Auto Completion** characteristic is set to **Y** for the business object, the system does not automatically complete the respective To Do entry.

## C1-MRECONVAL

This algorithm is invoked when you submit the pay instruction file for reconciliation. It checks the following:

- The payment is not associated with any other reconciliation which is in the status other than **Pending Cancellation** or **Canceled**.



- The payment ID and payor account ID are both available for further processing.

It contains the following parameters:

- **Reconciliation Canceled Status** – Used to specify the status code to which the reconciliation in the **Pending Cancellation** status is transitioned when the **Reconciliation Cancellation Periodic Monitor (C1-RCNMD)** batch is executed.
- **Reconciliation Pending Cancellation Status** - Used to specify the status code to which the reconciliation is transitioned when you click the **Cancel** button.

Both these parameters are mandatory.

## C1-MONPAYINS

This algorithm is invoked when the status of the reconciliation is changed to **Initial Reconciliation in Progress** or **Reconciliation in Progress**. It monitors or checks whether there are any pay instructions in the following statuses:

- Reconciliation Pending Processing
- Derivation Pending Processing
- Completed

If all pay instructions in the reconciliation are in the **Completed** status, then the status of the reconciliation is changed to **Completed**. However, if there are any pay instructions in the **Reconciliation Pending Processing** or **Derivation Pending Processing** status, then the status of reconciliation is changed to **Open**.

This algorithm contains the following parameters:

- **Pay Instruction Derivation Pending Processing Status** - Used to specify the status code to which the pending pay instruction is transitioned when the number of pay instructions in the reconciliation exceeds the deferred processing threshold (specified in an algorithm which is created using the **C1-RCOPNPYIN** algorithm type).
- **Pay Instruction Reconciliation Pending Processing Status** - Used to specify the status code to which the open pay instruction is transitioned when the number of pay instructions in the reconciliation exceeds the deferred processing threshold (specified in an algorithm which is created using the **C1-RCOPNPYIN** algorithm type).
- **Pay Instruction Completed Status** - Used to specify the status code to which the pay instruction is transitioned when it is fully reconciled.
- **Reconciliation Open Status** - Used to specify the status code to which you want to transition the reconciliation when there is a pay instruction in the status which is specified in the **Pay Instruction Derivation Pending Processing Status** or **Pay Instruction Reconciliation Pending Processing Status** parameter.
- **Reconciliation Completed Status** - Used to specify the status code to which you want to transition the reconciliation when all its pay instructions are in the status which is specified in the **Pay Instruction Completed Status** parameter.

All these parameters are mandatory.

## C1-TRNPAYRCN

This algorithm transfers the payment amount from the payor account's contract to the reconciliation contract of the accounts for which you have received the pay instruction. In this process, the payment against the payor account's contract is canceled and the payment against the payee account's reconciliation contract is created in the **Frozen** status.

It contains the following parameters:

- **Payment Cancel Reason** – Used to indicate the reason that you want to use when the payment on the payor account's contract is canceled.
- **Reconciliation Contract Match Type** – Used to specify the match type using which you want to apply payment against the reconciliation contract.

Both these parameters are mandatory.

## C1-RCOPNPYIN

This algorithm checks whether the number of pay instructions in the reconciliation exceeds the limit defined in the **Deferred Processing Threshold** parameter. If the status of the pay instruction is **Pending** and the number of pay instructions in the reconciliation exceeds the limit defined in the **Deferred Processing Threshold** parameter, then the status of the pay instruction is changed to the value defined in the **Pay Instruction Derivation Pending Processing Status** parameter.

However, if the status of the pay instruction is **Open** and the number of pay instructions in the reconciliation exceeds the limit defined in the **Deferred Processing Threshold** parameter, then the status of the pay instruction is changed to the value defined in the **Pay Instruction Reconciliation Pending Processing Status** parameter.

It contains the following parameters:

- **Pay Instruction Pending Status** – Used to specify the status code to which a pay instruction is transitioned when its validation is successful.
- **Pay Instruction Open Status** – Used to specify the status code to which a pay instruction is transitioned when it is not fully reconciled.
- **Pay Instruction Derivation Pending Processing Status** – Used to specify the status code to which you want to transition the pending pay instruction when the number of pay instructions in the reconciliation exceeds the deferred processing threshold limit.
- **Pay Instruction Reconciliation Pending Processing Status** – Used to specify the status code to which you want to transition the open pay instruction when the number of pay instructions in the reconciliation exceeds the deferred processing threshold limit.
- **Deferred Processing Threshold** – Used to specify the maximum number of pay instructions that can be reconciled in the real time (i.e. immediately). If the number of pay instructions in the reconciliation exceeds the deferred processing threshold limit, the pay instruction is reconciled in the deferred mode.

All these parameters are mandatory.

## C1-RCNOPNMR

This algorithm initiates the reconciliation process for the past open reconciliation records of the account. It contains the following parameters:

- **Reconciliation Open Status** – Used to specify the status code to which the reconciliation is transitioned when its pay instruction is not fully reconciled.
- **Reconciliation In Progress Status** – Used to specify the status code to which you want to transition the past open reconciliation record when the current reconciliation record of the account is reconciled.

Both these parameters are mandatory.

## C1-RCMONPNCN

This algorithm is invoked when the **Reconciliation Cancellation Periodic Monitor (C1-RCNMD)** batch is executed. It checks whether the reason is specified while canceling the reconciliation. If the cancel reason is specified, the status of the reconciliation is changed to **Canceled**. However, if the cancel reason is not specified, an error occurs while executing the **Reconciliation Cancellation Periodic Monitor (C1-RCNMD)** batch.

It contains the following parameters:

- **Reconciliation Cancel Status Reason** -  
Used to specify the cancel reason. If you specify the value for this parameter, the system will validate whether the cancel reason specified while canceling the reconciliation matches the cancel reason specified in this parameter. If the cancel reason does not match, an error occurs while executing the **Reconciliation Cancellation Periodic Monitor (C1-RCNMD)** batch. You must specify a reason which is defined for the **Pending Cancellation** status of the **C1-MemberReconciliation** business object.

## C1-CANPAYINS

This algorithm is invoked when the **Reconciliation Cancellation Periodic Monitor (C1-RCNMD)** batch is executed. It changes the status of all pay instructions in the reconciliation.

It contains the following parameter:

- **Pay Instruction Canceled Status** – Used to specify the status code to which you want to transition a pay instruction when the reconciliation is canceled. This parameter is mandatory.

## C1-CANRCNPAY

This algorithm transfers the payment amount from the payee account's reconciliation contract to the payor account's contract. In this process, the payment against the reconciliation contract is canceled and the payment against the payor account's contract is created in the **Frozen** status.

It contains the following parameters:

- **Payment Cancel Reason** – Used to indicate the reason that you want to use when the payment against the payee account's reconciliation contract is canceled.
- **On Account Match Type** – Used to specify the match type using which you want to apply the payment against the contract of the payor account.

Both these parameters are mandatory.

## C1-RCNCANLTD

This algorithm is invoked when the status of the reconciliation is changed to **Canceled**. It creates a To Do using the specified To Do type and assigns it to users with the specified To Do role.

It contains the following parameters:

- **To Do Type** – Used to specify the type of notification that you want to generate when the reconciliation is canceled.
- **To Do Role** – Used to specify the To Do role to indicate the users to whom you want to send the notification when the reconciliation is canceled.

The rest of the parameters, such as **To Do Type Element Name**, **To Do Role Element Name**, **Message Category**, **Message Number**, **Characteristic Type For Log Entry**, **To Do Sort Keys Retriever Script**, **Discard Cancel Terminate Reason Element**, **Discard Cancel Terminate Reason**, **Retry Frequency**, and **Retry Frequency Element Name**, are not used at the moment.

## Algorithms Used in C1-PayInstruction

The following table lists the algorithms which are attached to the **C1-PayInstruction** business object:

System Event	Algorithm	Algorithm Type	Description
Information	C1-MPAYININF	C1-MPAYININF	Refer to <a href="#">C1-MPAYININF</a> on page 2228

The following table lists the algorithms which are used in the lifecycle of the **C1-PayInstruction** business object:

Status	System Event	Algorithm	Algorithm Type	Description
Pending	-	-	-	-

Status	System Event	Algorithm	Algorithm Type	Description
Derivation In Progress	Enter	C1-PYINDRVAN	C1-PYINDRVAN	Refer to <a href="#">C1-PYINDRVAN</a> on page 2228
Reconciliation In Progress	Enter	C1-PIRECOCIL	C1-PIRECOCIL	Refer to <a href="#">C1-PIRECOCIL</a> on page 2229
Open	-	-	-	-
Complete	-	-	-	-
Cancelled	Enter	C1-PYICNADJ	C1-PYICNADJ	Refer to <a href="#">C1-PYICNADJ</a> on page 2230
Derivation Pending Processing	Monitor	F1-AT-RQJ	F1-GEN-BOMNJ	Refer to <a href="#">F1-AT-RQJ</a> on page 1257
Reconciliation Pending Processing	Monitor	F1-AT-RQJ	F1-GEN-BOMNJ	Refer to <a href="#">F1-AT-RQJ</a> on page 1257
Error	-	-	-	-

## C1-MPAYININF

This algorithm generates the pay instruction information string which appears throughout the application. It concatenates the following fields separated by a comma in the specified order:

- “Period:” Start Date - End Date
- Pay Instruction Amount
- Pay Instruction Status
- Payor Name
- Pay Instruction ID

## C1-PYINDRVAN

This algorithm is invoked when the status of the pay instruction is changed to **Derivation in Progress**. It derives the following:

- Policy using the policy number
- Plan using the plan number
- Member using the member identifier type and member identifier
- Payee account using the account identifier type and account identifier

If the policy, plan, and member information is available, it validates whether the member is covered under the specified plan of the policy. However, if the policy and plan information is available, it validates whether the plan is included in the specified policy. If the derivation and validation process is successful, the related object information is derived for policy, plan, and/or member from the system.

However, if the derivation and validation process fails, the related object information is not derived for policy, plan, and/or member and the status of the pay instruction remains as **Pending**.

In addition, the system determines whether the pay instruction must be reconciled at the member, plan, or policy level depending on the information available in the pay instruction. If the policy, plan, and member information is available, the pay instruction is reconciled at the member level. If the policy and plan information is available, the pay instruction is reconciled at the policy plan level. However, if the policy information is available, the pay instruction is reconciled at the policy level.

It contains the following parameters:

- **Unsuccessful Processing Status** – Used to specify the status code to which you want to transition the pay instruction when the derivation and validation process fails.
- **Pay Instruction Matching Level Characteristic Type** – Used to specify the characteristic type which indicates whether the pay instruction must be reconciled at the member, plan, or policy level. This type of characteristic is defined on the pay instruction. Here, you must specify a characteristic type where the characteristic entity is set to **Payment Instruction**.
- **Member Matching Level Characteristic Value** – Used to specify the value that you want to define for the characteristic type specified in the **Pay Instruction Matching Level Characteristic Type** parameter when the pay instruction must be reconciled at the member level.
- **Plan Matching Level Characteristic Value** - Used to specify the value that you want to define for the characteristic type specified in the **Pay Instruction Matching Level Characteristic Type** parameter when the pay instruction must be reconciled at the policy plan level.
- **Policy Matching Level Characteristic Value** - Used to specify the value that you want to define for the characteristic type specified in the **Pay Instruction Matching Level Characteristic Type** parameter when the pay instruction must be reconciled at the policy level.

All these parameters are mandatory.

## C1-PIRECOCIL

This algorithm is invoked when the status of the pay instruction is changed to **Reconciliation in Progress**. It searches whether there is an open bill segment with the policy, plan, member, and coverage period combination for the payee account. If such bill segment exists in the system, this algorithm reconciles the pay instruction against the open bill segment. It creates two reconciliation adjustments – one against the payee account’s reconciliation contract and another against the bill segment’s contract.

If the amount on the pay instruction is fully reconciled, then the status of the pay instruction is changed to **Completed**. However, if the amount on the pay instruction is not fully reconciled, then the status of the pay instruction is changed to **Open**.

It contains the following parameters:

- **Pay Instruction Matching Level Characteristic Type** – Used to specify the characteristic type which indicates whether the pay instruction must be reconciled at the member, plan, or policy level. This type of characteristic is defined on the pay instruction. Here, you must specify a characteristic type where the characteristic entity is set to **Payment Instruction**.
- **Member Matching Level Characteristic Value** – Used to specify the value of the characteristic type specified in the **Pay Instruction Matching Level Characteristic Type** parameter which indicates that the pay instruction must be reconciled at the member level.
- **Plan Matching Level Characteristic Value** – Used to specify the value of the characteristic type specified in the **Pay Instruction Matching Level Characteristic Type** parameter which indicates that the pay instruction must be reconciled at the policy plan level.
- **Policy Matching Level Characteristic Value** – Used to specify the value of the characteristic type specified in the **Pay Instruction Matching Level Characteristic Type** parameter which indicates that the pay instruction must be reconciled at the policy level.
- **Adjustment Type for Bill Segment Contract** – Used to specify the adjustment type using which you want to create the adjustment on the bill segment’s contract when the pay instruction is reconciled.
- **Adjustment Type for Reconciliation Contract** – Used to specify the adjustment type using which you want to create the adjustment on the reconciliation contract when the pay instruction is reconciled.
- **Reconciliation Open Status** – Used to specify the status code to which you want to transition the reconciliation when the status of the pay instruction is changed to **Open**.

- **Pay Instruction Open Status** – Used to specify the status code to which you want to transition the pay instruction when it is not fully reconciled.
- **Pay Instruction Completed Status** – Used to specify the status code to which you want to transition the pay instruction when it is fully reconciled.
- **Reconciliation Characteristic Type** – Used to specify the characteristic type which you want to use to store the reconciliation ID. This type of characteristic is defined on the adjustments which are created on reconciliation. Here, you must specify a characteristic type where the characteristic entity is set to **Adjustment Type**.
- **Payment Event Characteristic Type** – Used to specify the characteristic type which you want to use to store the payment event ID. This type of characteristic is defined on the reconciliation adjustments to indicate the payment event whose payment is distributed against the bill segment.
- **Adjustment Type for Offsetting Debits against Billed Credits** – Used to specify the adjustment type using which you want to create the adjustments when offsetting billed debit verses billed credits.

All these parameters are mandatory.

## C1-PYICNADJ

This algorithm is invoked when the status of the pay instruction is changed to **Canceled**. It cancels the reconciliation adjustments which are created while reconciling the pay instruction. It cancels the reconciliation adjustment irrespective of whether the status of the pay instruction is **Open** or **Completed**.

It contains the following parameters:

- **Adjustment Cancel Reason** – Used to indicate the reason that you want to use when the reconciliation adjustments are canceled.
- **Pay Instruction Completed Status** – Used to specify the status code to which the pay instruction is transitioned when it is fully reconciled.
- **Pay Instruction Open Status** – Used to specify the status code to which the pay instruction is transitioned when it is not fully reconciled.
- **Reconciliation Completed Status** – Used to specify the status code to which the reconciliation is transitioned when all its pay instructions are fully reconciled.
- **Reconciliation Open Status** – Used to specify the status code to which the reconciliation is transitioned when its pay instruction is not fully reconciled.

All these parameters are mandatory.

## F1-AT-RQJ

This algorithm transitions the current status of the business object to the specified status. It contains the following parameters:

- **Next Status** – Used when you want to override the default next status specified in the lifecycle.
- **Next Transition Condition** – Used when you want to override the default next transition condition specified in the lifecycle.

At a time, you can specify value for either the **Next Status** or **Next Transition Condition** parameter. If you don't specify any value for these parameters, the system will transition the business object to the default next status specified in its lifecycle.

## Algorithms Used in C1-MemberDiscReportType

---

The following table lists the algorithms which are attached to the **C1-MemberDiscReportType** business object:

System Event	Algorithm	Algorithm Type	Description
Pre-Processing	C1-DISCPEP	C1-DISCPEP	Refer to <a href="#">C1-DISCPEP</a> on page 2231

## C1-DISCPEP

This algorithm validates a discrepancy report type. It checks the following:

- A duplicate characteristic type is not added.

In addition, it does not allow you to:

- Delete a discrepancy report type when the corresponding discrepancy report is in a status other than **Completed**.

## Algorithms Used in C1-DiscrepancyReport

The following table lists the algorithms which are attached to the **C1-DiscrepancyReport** business object:

System Event	Algorithm	Algorithm Type	Description
Information	C1-DISRINFO	C1-DISRINFO	Refer to <a href="#">C1-DISRINFO</a> on page 2231

The following table lists the algorithms which are used in the lifecycle of the **C1-DiscrepancyReport** business object:

Status	System Event	Algorithm	Algorithm Type	Description
Draft	Monitor	F1-AT-RQJ	F1-GEN-BOMNJ	Refer to <a href="#">F1-AT-RQJ</a> on page 1257
	Enter	C1-VALNEWDIS	C1-VALNEWDIS	Refer to <a href="#">C1-VALNEWDIS</a> on page 2232
Pending	Enter	C1-CRDSLNTM	C1-CRDSLNTM	Refer to <a href="#">C1-CRDSLNTM</a> on page 2232
	Exit	F1-TODOCOMPL	F1-TODOCOMPL	Refer to <a href="#">F1-TODOCOMPL</a> on page 1256
Completed	Enter	C1-VALCMPDIS	C1-VALCMPDIS	Refer to <a href="#">C1-VALCMPDIS</a> on page 2232

## F1-AT-RQJ

This algorithm transitions the current status of the business object to the specified status. It contains the following parameters:

- **Next Status** – Used when you want to override the default next status specified in the lifecycle.
- **Next Transition Condition** – Used when you want to override the default next transition condition specified in the lifecycle.

At a time, you can specify value for either the **Next Status** or **Next Transition Condition** parameter. If you don't specify any value for these parameters, the system will transition the business object to the default next status specified in its lifecycle.

## C1-DISRINFO

This algorithm generates the discrepancy report information string which appears throughout the application. It concatenates the following fields separated by a comma in the specified order:

- Discrepancy Report Type Description
- Discrepancy Report Status

- Discrepancy Report ID

## C1-VALNEWDIS

This algorithm allows you to create a discrepancy report only when the following conditions are met:

- The account for which discrepancy report is created is eligible for reconciliation.
- A discrepancy report in the **Pending** status does not exist for the account or file.
- A reconciliation record in the **Open** status exists for the account or file.

It contains the following parameters:

- **Eligible for Reconciliation Characteristic Type** – Used to specify the characteristic type which indicates whether the account is eligible for reconciliation. Here, you must specify a characteristic type where the characteristic entity is set to **Account**.
- **Eligible for Reconciliation Characteristic Value** – Used to specify the value of the characteristic type specified in the **Eligible for Reconciliation Characteristic Type** parameter which indicates that the account is eligible for reconciliation.

Both these parameters are mandatory.

## C1-CRDSLNTM

This algorithm is invoked when the status of the discrepancy report is changed to **Pending**. If the discrepancy report is created at the account level, this algorithm creates a discrepancy line item for each policy, plan, member, and coverage period combination for which there is an open bill segment for the account and for which there are open and pending pay instructions in the open reconciliation.

However, if the discrepancy report is created at the file level, this algorithm creates a discrepancy line item for each policy, plan, member, and coverage period combination for which there are open and pending pay instructions in the open reconciliation. Note that the discrepancy line items are created for each account whose pay instructions are received in the pay instruction file.

It contains the following parameters:

- **Consumer Status Characteristic Type** – Used to specify the characteristic type which stores the consumer status of the member. The system retrieves the consumer status of the member and stores it against the respective discrepancy line item. Here, you must specify a characteristic type where the characteristic entity is set to **Person**. This parameter is mandatory.

## F1-TODOCOMPL

This algorithm completes To Do entries that are created for the business object when the business object exits the given status. It finds and completes all open To Do entries where the business object's primary key is defined as a drill key. However, if the **Exclude To Do Entries From Auto Completion** characteristic is set to **Y** for the business object, the system does not automatically complete the respective To Do entry.

## C1-VALCMPDIS

This algorithm is invoked when you click the **Finalize** button. It changes the status of the discrepancy report to **Completed** only when the discrepancy category is specified for each discrepancy line item in the report.

## Reconciliation Type

---

Oracle Revenue Management and Billing allows you to define a reconciliation type using which you can create the reconciliation. It is the reconciliation type which helps the system to determine:

- The business object using which the reconciliation should be created.



- The file format through which the pay instruction records can be uploaded in the system.



In addition, a reconciliation type indicates the algorithm which validates the pay instruction file and creates a pay instruction for each record in the file. Two algorithm types named **C1-PAYINSUPL** and **C1-RECONPROC** are shipped with the product. You need to maintain separate reconciliation types for different file formats. If you want to use a reconciliation type while uploading a pay instruction file in the CSV format, you need to create an algorithm using the **C1-PAYINSUPL** algorithm type and attach it to the reconciliation type. However, if you want to use a reconciliation type while uploading a pay instruction file in the EDI 820 format, you need to create an algorithm using the **C1-RECONPROC** algorithm type and attach it to the reconciliation type.

The **Reconciliation Type** screen allows you to define, edit, copy, and delete a reconciliation type. It contains the following zones:

- [Reconciliation Type List](#) on page 2233
- [Reconciliation Type](#) on page 2233

## Reconciliation Type List

The **Reconciliation Type List** zone lists the reconciliation types that are already defined in the system. It contains the following columns:

Column Name	Column Description
Reconciliation Type	Displays the reconciliation type.
Description	Displays the description of the reconciliation type.
Edit	On clicking the <b>Edit</b> (  ) icon, the <b>Reconciliation Type</b> screen appears where you can edit the details of the reconciliation type.
Duplicate	On clicking the <b>Duplicate</b> (  ) icon, the <b>Reconciliation Type</b> screen appears where you can define a new reconciliation type using an existing reconciliation type.
Delete	On clicking the <b>Delete</b> (  ) icon, you can delete the reconciliation type.  <b>Note:</b> You can delete a reconciliation type only when you have not created a reconciliation using the reconciliation type.

On clicking the **Broadcast** () icon corresponding to a reconciliation type, the **Reconciliation Type** zone appears with the details of the respective reconciliation type.

### Related Topics

For more information on...	See...
How to edit a reconciliation type	<a href="#">Editing a Reconciliation Type</a> on page 2239
How to delete a reconciliation type	<a href="#">Deleting a Reconciliation Type</a> on page 2240
How to copy a reconciliation type	<a href="#">Copying a Reconciliation Type</a> on page 2241
How to view the details of a reconciliation type	<a href="#">Viewing the Reconciliation Type Details</a> on page 2242

## Reconciliation Type

The **Reconciliation Type** zone displays the details of the reconciliation type. It contains the following sections:

- **Main** - Displays basic information about the reconciliation type. It contains the following fields:

Field Name	Field Description
Reconciliation Type	Displays the reconciliation type.
Reconciliation Business Object	Indicates the business object using which the reconciliation will be created. In addition, a context menu appears corresponding to this field which helps in navigating to other screens in the application.  <b>Note:</b> It has a link. On clicking the link, the <b>Business Object</b> screen appears where you can view the details of the respective business object.
Description	Displays the description of the reconciliation type.
Detailed Description	Indicates the status of the reconciliation type. The valid values are: <ul style="list-style-type: none"> <li>Active</li> <li>Inactive</li> </ul>
Status	Displays additional information about the reconciliation type.

- **Algorithms** - Lists the algorithms which are associated with the reconciliation type. It contains the following columns:

Column Name	Column Description
Sequence	Indicates the order in which the algorithms with the same system event should be executed.
System Event	Indicates the system event when the algorithm should be executed. The valid value is: <ul style="list-style-type: none"> <li>Upload Pay Instructions</li> </ul>
Algorithm	Indicates the algorithm attached to the system event.  <b>Note:</b> It has a link. On clicking the link, the <b>Algorithm</b> screen appears where you can view the details of the respective algorithm.

- **Characteristics** - Lists the characteristics defined for the reconciliation type. It contains the following columns:

Column Name	Column Description
Characteristic Type	Indicates the characteristic type.
Characteristic Value	Displays the value of the characteristic type.
Description	Displays the description of the characteristic value.  <b>Note:</b> The data appears in this column only when the type of characteristic value is set to <b>Predefined Value</b> or <b>Foreign Key Value</b> .

- **Record Actions** - This section contains the following buttons:

Button Name	Button Description
Edit	Used to edit the details of the reconciliation type.

Button Name	Button Description
Delete	Used to delete the reconciliation type.  <b>Note:</b> You can delete a reconciliation type only when you have not created a reconciliation using the reconciliation type.
Duplicate	Used to create a new reconciliation type using an existing reconciliation type.

- **Record Information** - This section contains the following field:

Field Name	Field Description
Business Object	Indicates the business object using which the reconciliation type is created. In addition, a context menu appears corresponding to this field which helps in navigating to other screens in the application.  <b>Note:</b> It has a link. On clicking the link, the <b>Business Object</b> screen appears where you can view the details of the respective business object.

By default, the **Reconciliation Type** zone does not appear in the **Reconciliation Type** screen. It appears only when you click the **Broadcast**  icon corresponding to a reconciliation type in the **Reconciliation Type List** zone.

### **Related Topics**

For more information on...	See...
How to edit a reconciliation type	<a href="#">Editing a Reconciliation Type</a> on page 2239
How to delete a reconciliation type	<a href="#">Deleting a Reconciliation Type</a> on page 2240
How to copy a reconciliation type	<a href="#">Copying a Reconciliation Type</a> on page 2241
How to view the details of a reconciliation type	<a href="#">Viewing the Reconciliation Type Details</a> on page 2242

## Defining a Reconciliation Type

### **Prerequisites**

To define a reconciliation type, you should have:

- Reconciliation business objects defined in the application

### **Procedure**

To define a reconciliation type:

1. Click the **Admin** link in the **Application** toolbar.  
A list appears.
2. From the **Admin** menu, select **R** and then click **Reconciliation Type**.  
A sub-menu appears.
3. Click the **Add** option from the **Reconciliation Type** sub-menu.

The **Select Business Object** screen appears. It contains the following field:

Field Name	Field Description	Mandatory (Yes or No)
Reconciliation Type Business Object	Used to indicate the business object using which you want to create the reconciliation type.	Yes

**Tip:** Alternatively, you can access this screen by clicking the **Add** button in the **Page Title** area of the **Reconciliation Type** screen.

**Note:** The **Select Business Object** screen appears only when there are multiple reconciliation type business objects defined in the application. If there is only one reconciliation type business object defined in the application, the **Reconciliation Type** screen appears.

4. Select the required reconciliation type business object from the respective field.
5. Click **OK**.

The **Reconciliation Type** screen appears. It contains the following sections:

- **Main** - Used to specify basic details about the reconciliation type.
- **Algorithms** - Used to associate algorithms with the reconciliation type.
- **Characteristics** - Used to define characteristics for the reconciliation type.

The **Main** section contains the following fields:

Field Name	Field Description	Mandatory (Yes or No)
Reconciliation Type	Used to specify the reconciliation type.	Yes
Business Object	Indicates the reconciliation type business object using which you are defining the reconciliation type.	Not applicable
Reconciliation Business Object	Used to indicate the business object using which you want to create the reconciliation.	Yes
Description	Used to specify the description for the reconciliation type.	Yes
Detailed Description	Used to specify additional information about the reconciliation type.	No
Status	Used to indicate the status of the reconciliation type. The valid values are: <ul style="list-style-type: none"> <li>• Active</li> <li>• Inactive</li> </ul>	Yes

6. Enter the required details in the **Main** section.
7. Associate algorithms with the reconciliation type, if required.
8. Define characteristics for the reconciliation type, if required.
9. Click **Save**.

The reconciliation type is defined.

### **Related Topics**

For more information on...	See...
<b>Reconciliation Type</b> screen	<a href="#">Reconciliation Type</a> on page 2232
How to associate an algorithm with a reconciliation type	<a href="#">Associating an Algorithm with a Reconciliation Type</a> on page 2237
How to define characteristics for a reconciliation type	<a href="#">Defining Characteristics for a Reconciliation Type</a> on page 2237

## Defining Characteristics for a Reconciliation Type

### Prerequisites

To define characteristics for a reconciliation type, you should have:

- Characteristic types defined in the application (where the characteristic entity is set to **Reconciliation Type**).

### Procedure

To define characteristics for a reconciliation type:

1. Ensure that the **Characteristics** section is expanded when you are defining, editing, or copying a reconciliation type.

The **Characteristics** section contains the following fields in a grid:

Field Name	Field Description	Mandatory (Yes or No)
Characteristic Type	Used to indicate the characteristic type.  <b>Note:</b> The list includes only those characteristic types where the characteristic entity is set to <b>Reconciliation Type</b> .	Yes (Conditional)  <b>Note:</b> This field is required when you are defining a characteristic for the reconciliation type.
Characteristic Value	Used to specify the value for the characteristic type.  <b>Note:</b> On specifying the value for a predefined characteristic type, the description of the characteristic value appears corresponding to the <b>Characteristic Value</b> field.	Yes (Conditional)  <b>Note:</b> This field is required when you are defining a characteristic for the reconciliation type.

2. Enter the required details in the **Characteristics** section.

**Note:** If you select a predefined characteristic type, the **Search** (🔍) icon appears corresponding to the **Characteristic Value** field. On clicking the **Search** icon, you can search for a predefined characteristic value.

3. If you want to define more than one characteristic for the reconciliation type, click the **Add** (+) icon and then repeat step 2.

**Note:** However, if you want to remove a characteristic from the reconciliation type, click the **Delete** (🗑️) icon corresponding to the characteristic.

### Related Topics

For more information on...	See...
How to define a reconciliation type	<a href="#">Defining a Reconciliation Type</a> on page 2235
How to edit a reconciliation type	<a href="#">Editing a Reconciliation Type</a> on page 2239
How to copy a reconciliation type	<a href="#">Copying a Reconciliation Type</a> on page 2241

## Associating an Algorithm with a Reconciliation Type

You can upload a pay instruction file in the CSV and EDI 820 file formats. While uploading a pay instruction file, you need to specify the reconciliation type using which you want to create the reconciliation. A reconciliation type indicates the algorithm which validates the pay instruction file and creates a pay instruction for each record in the file. Two

algorithm types named **C1-PAYINSUPL** and **C1-RECONPROC** are shipped with the product. You need to maintain separate reconciliation types for different file formats. If you want to use a reconciliation type while uploading a pay instruction file in the CSV format, you need to create an algorithm using the **C1-PAYINSUPL** algorithm type and attach it to the reconciliation type. However, if you want to use a reconciliation type while uploading a pay instruction file in the EDI 820 format, you need to create an algorithm using the **C1-RECONPROC** algorithm type and attach it to the reconciliation type.

### **Prerequisites**

To associate an algorithm with a reconciliation type, you should have:

- Algorithm defined using the **C1-PAYINSUPL** or **C1-RECONPROC** algorithm type depending on whether you want to use the reconciliation type while uploading a pay instruction file in the CSV or EDI 820 file format

### **Procedure**

To associate an algorithm with a reconciliation type:

1. Ensure that the **Algorithms** section is expanded when you are defining, editing, or copying a reconciliation type.

The **Algorithms** section contains the following fields in a grid:

Field Name	Field Description	Mandatory (Yes or No)
Sequence	Used to indicate the order in which the algorithms with the same system event should be executed.	Yes (Conditional) <b>Note:</b> This field is required when you are associating an algorithm with the reconciliation type.
System Event	Used to indicate the system event when the algorithm should be executed. The valid value is: <ul style="list-style-type: none"> <li><b>Upload Pay Instructions</b> - Used when you want to execute the attached algorithm while uploading a pay instruction file using the <b>Pay Instruction CSV File Upload (C1-RECUP)</b> or <b>Upload Lockbox Payment and Pay Instruction Files (C1-PUPSG)</b> batch.</li> </ul>	Yes (Conditional) <b>Note:</b> This field is required when you are associating an algorithm with the reconciliation type.
Algorithm	Used to indicate the algorithm that you want to attach to the system event. <b>Note:</b> The <b>Search</b>  icon appears corresponding to this field. On clicking the <b>Search</b> icon, the <b>Algorithm Search</b> window appears.	Yes (Conditional) <b>Note:</b> This field is required when you are associating an algorithm with the reconciliation type.

2. Enter the required details in the **Algorithms** section.
3. If you want to associate more than one algorithm with the reconciliation type, click the **Add**  icon and then repeat step 2.

**Note:** However, if you want to remove an algorithm from the reconciliation type, click the **Delete**  icon corresponding to the algorithm.

4. Click **Save**.

The algorithms are associated with the reconciliation type.

**Related Topics**

For more information on...	See...
How to define a reconciliation type	<a href="#">Defining a Reconciliation Type</a> on page 2235
How to edit a reconciliation type	<a href="#">Editing a Reconciliation Type</a> on page 2239
How to copy a reconciliation type	<a href="#">Copying a Reconciliation Type</a> on page 2241

**Editing a Reconciliation Type****Prerequisites**

To edit a reconciliation type, you should have:

- Reconciliation business objects defined in the application

**Procedure**

To edit a reconciliation type:

1. Click the **Admin** link in the **Application** toolbar.  
A list appears.
2. From the **Admin** menu, select **R** and then click **Reconciliation Type**.  
A sub-menu appears.
3. Click the **Search** option from the **Reconciliation Type** sub-menu.  
The **Reconciliation Type** screen appears.
4. In the **Reconciliation Type List** zone, click the **Edit** (✎) icon in the **Edit** column corresponding to the reconciliation type whose details you want to edit.

The **Reconciliation Type** screen appears. It contains the following sections:

- **Main** - Used to specify basic details about the reconciliation type.
- **Algorithms** - Used to associate algorithms with the reconciliation type.
- **Characteristics** - Used to define characteristics for the reconciliation type.

The **Main** section contains the following fields:

Field Name	Field Description	Mandatory (Yes or No)
Reconciliation Type	Displays the reconciliation type.	Not applicable
Business Object	Indicates the reconciliation type business object using which you are defining the reconciliation type.	Not applicable
Reconciliation Business Object	Used to indicate the business object using which you want to create the reconciliation.	Yes
Description	Used to specify the description for the reconciliation type.	Yes
Detailed Description	Used to specify additional information about the reconciliation type.	No

Field Name	Field Description	Mandatory (Yes or No)
Status	Used to indicate the status of the reconciliation type. The valid values are: <ul style="list-style-type: none"> <li>Active</li> <li>Inactive</li> </ul>	Yes

**Tip:** Alternatively, you can edit the details of a reconciliation type by clicking the **Edit** button in the **Reconciliation Type** zone.

- Modify the required details in the **Main** section.
- Associate or remove an algorithm from the reconciliation type, if required.
- Define, edit, or remove characteristics from the reconciliation type, if required.
- Click **Save**.

The changes made to the reconciliation type are saved.

### Related Topics

For more information on...	See...
<b>Reconciliation Type</b> screen	<a href="#">Reconciliation Type</a> on page 2232
<b>Reconciliation Type List</b> zone	<a href="#">Reconciliation Type List</a> on page 2233
<b>Reconciliation Type</b> zone	<a href="#">Reconciliation Type</a> on page 2233
How to associate an algorithm with a reconciliation type	<a href="#">Associating an Algorithm with a Reconciliation Type</a> on page 2237
How to define characteristics for a reconciliation type	<a href="#">Defining Characteristics for a Reconciliation Type</a> on page 2237

## Deleting a Reconciliation Type

### Procedure

To delete a reconciliation type:

- Click the **Admin** link in the **Application** toolbar.  
A list appears.
- From the **Admin** menu, select **R** and then click **Reconciliation Type**.  
A sub-menu appears.
- Click the **Search** option from the **Reconciliation Type** sub-menu.  
The **Reconciliation Type** screen appears.
- In the **Reconciliation Type List** zone, click the **Delete** (🗑️) icon in the **Delete** column corresponding to the reconciliation type that you want to delete.  
A message appears confirming whether you want to delete the reconciliation type.

**Note:** You can delete a reconciliation type only when you have not created a reconciliation using the reconciliation type.



**Tip:** Alternatively, you can delete a reconciliation type by clicking the **Delete** button in the **Reconciliation Type** zone.

5. Click **OK**.

The reconciliation type is deleted.

### **Related Topics**

<b>For more information on...</b>	<b>See...</b>
<b>Reconciliation Type</b> screen	<a href="#">Reconciliation Type</a> on page 2232
<b>Reconciliation Type List</b> zone	<a href="#">Reconciliation Type List</a> on page 2233
<b>Reconciliation Type</b> zone	<a href="#">Reconciliation Type</a> on page 2233

## **Copying a Reconciliation Type**

Instead of creating a reconciliation type from scratch, you can create a new reconciliation type using an existing reconciliation type. This is possible through copying a reconciliation type. On copying a reconciliation type, the details including the algorithms and characteristics are copied to the new reconciliation type. You can then edit the details, if required.

### **Prerequisites**

To copy a reconciliation type, you should have:

- Reconciliation type (whose copy you want to create) defined in the application
- Reconciliation business objects defined in the application

### **Procedure**

To copy a reconciliation type:

1. Click the **Admin** link in the **Application** toolbar.

A list appears.

2. From the **Admin** menu, select **R** and then click **Reconciliation Type**.

A sub-menu appears.

3. Click the **Search** option from the **Reconciliation Type** sub-menu.

The **Reconciliation Type** screen appears.

4. In the **Reconciliation Type List** zone, click the **Duplicate** () icon in the **Duplicate** column corresponding to the reconciliation type whose copy you want to create.

The **Reconciliation Type** screen appears. It contains the following sections:

- **Main** - Used to specify basic details about the reconciliation type.
- **Algorithms** - Used to associate algorithms with the reconciliation type.
- **Characteristics** - Used to define characteristics for the reconciliation type.

The **Main** section contains the following fields:

<b>Field Name</b>	<b>Field Description</b>	<b>Mandatory (Yes or No)</b>
Reconciliation Type	Used to specify the reconciliation type.	Yes
Business Object	Indicates the reconciliation type business object using which you are defining the reconciliation type.	Not applicable

Field Name	Field Description	Mandatory (Yes or No)
Reconciliation Business Object	Used to indicate the business object using which you want to create the reconciliation.	Yes
Description	Used to specify the description for the reconciliation type.	Yes
Detailed Description	Used to specify additional information about the reconciliation type.	No
Status	Used to indicate the status of the reconciliation type. The valid values are: <ul style="list-style-type: none"> <li>• Active</li> <li>• Inactive</li> </ul>	Yes

**Tip:** Alternatively, you can copy a reconciliation type by clicking the **Duplicate** button in the **Reconciliation Type** zone.

5. Enter the required details in the **Main** section.
6. Associate or remove an algorithm from the reconciliation type, if required.
7. Define, edit, or remove characteristics from the reconciliation type, if required.
8. Click **Save**.

The new reconciliation type is defined.

#### Related Topics

For more information on...	See...
<b>Reconciliation Type</b> screen	<a href="#">Reconciliation Type</a> on page 2232
<b>Reconciliation Type List</b> zone	<a href="#">Reconciliation Type List</a> on page 2233
<b>Reconciliation Type</b> zone	<a href="#">Reconciliation Type</a> on page 2233
How to associate an algorithm with a reconciliation type	<a href="#">Associating an Algorithm with a Reconciliation Type</a> on page 2237
How to define characteristics for a reconciliation type	<a href="#">Defining Characteristics for a Reconciliation Type</a> on page 2237

## Viewing the Reconciliation Type Details

### Procedure

To view the details of a reconciliation type:

1. Click the **Admin** link in the **Application** toolbar.  
A list appears.
2. From the **Admin** menu, select **R** and then click **Reconciliation Type**.  
A sub-menu appears.
3. Click the **Search** option from the **Reconciliation Type** sub-menu.  
The **Reconciliation Type** screen appears.

4. In the **Reconciliation Type List** zone, click the **Broadcast**  icon corresponding to the reconciliation type whose details you want to view.  
The **Reconciliation Type** zone appears.
5. View the details of the reconciliation type in the **Reconciliation Type** zone.

### Related Topics

For more information on...	See...
<b>Reconciliation Type</b> screen	<a href="#">Reconciliation Type</a> on page 2232
<b>Reconciliation Type List</b> zone	<a href="#">Reconciliation Type List</a> on page 2233
<b>Reconciliation Type</b> zone	<a href="#">Reconciliation Type</a> on page 2233

## Reconciliation (Used for Searching)

The **Reconciliation** screen allows you to search for a reconciliation using various search criteria. It contains the following zone:

- [Search Reconciliation](#) on page 2243

Through this screen, you can navigate to the following screen:

- [Reconciliation \(Used for Viewing\)](#) on page 2247

## Search Reconciliation

The **Search Reconciliation** zone allows you to search for a reconciliation using various search criteria. This zone contains the following sections:

- **Search Criteria** - The **Search Criteria** section contains the following fields:

Field Name	Field Description	Mandatory (Yes or No)
Search By	Used to indicate whether you want to search for a reconciliation using the reconciliation, payee account, or payment tender details. The valid values are: <ul style="list-style-type: none"> <li>• Reconciliation Details</li> <li>• Account Details</li> <li>• Payment Tender Details</li> </ul> <div style="border: 1px solid black; padding: 2px; margin-top: 5px;"><b>Note:</b> By default, the <b>Reconciliation Details</b> option is selected.</div>	Yes
Reconciliation ID	Used to search a particular reconciliation. <div style="border: 1px solid black; padding: 2px; margin-top: 5px;"><b>Note:</b> This field appears only when you select the <b>Reconciliation Details</b> option from the <b>Search By</b> list.</div>	No
Reconciliation Type	Used to search reconciliations which are created using a particular reconciliation type. <div style="border: 1px solid black; padding: 2px; margin-top: 5px;"><b>Note:</b> This field appears only when you select the <b>Reconciliation Details</b> option from the <b>Search By</b> list.</div>	No

Field Name	Field Description	Mandatory (Yes or No)
Created From	Used to search reconciliations which are created from a particular date onwards.  <b>Note:</b> This field appears only when you select the <b>Reconciliation Details</b> option from the <b>Search By</b> list.	No
Status	Used to search reconciliations with a particular status. The valid values are: <ul style="list-style-type: none"> <li>• Canceled</li> <li>• Completed</li> <li>• Draft</li> <li>• Initial Reconciliation in Progress</li> <li>• Open</li> <li>• Pending Cancellation</li> <li>• Pending</li> <li>• Pending Reconciliation</li> <li>• Reconciliation in Progress</li> </ul> <b>Note:</b> This field appears only when you select the <b>Reconciliation Details</b> option from the <b>Search By</b> list.	No
Created Until	Used to search reconciliations which are created till a particular date.  <b>Note:</b> This field appears only when you select the <b>Reconciliation Details</b> option from the <b>Search By</b> list.	No
File Name	Used to search a reconciliation which is created for a particular pay instruction file.  <b>Note:</b> This field appears only when you select the <b>Reconciliation Details</b> option from the <b>Search By</b> list.	No
Person Name	Used to search reconciliations which contain a particular member's pay instructions.  <b>Note:</b> This field appears only when you select the <b>Account Details</b> option from the <b>Search By</b> list.	No
Account Identifier Type	Used to select the identifier type based on which you want to search reconciliations which contain pay instructions for a particular payee account.  <b>Note:</b> This field appears only when you select the <b>Account Details</b> option from the <b>Search By</b> list.	Yes (Conditional)  <b>Note:</b> If you specify the account identifier as a search criteria, you have to select the account identifier type.

Field Name	Field Description	Mandatory (Yes or No)
Account ID	Used to search reconciliations which contain pay instructions for a particular payee account.  <b>Note:</b> This field appears only when you select the <b>Account Details</b> option from the <b>Search By</b> list.	No
Account Identifier	Used to specify the value for the account identifier type.  <b>Note:</b> This field appears only when you select the <b>Account Details</b> option from the <b>Search By</b> list.	Yes (Conditional)  <b>Note:</b> If you specify the account identifier type as a search criteria, you have to specify the account identifier.
Check Number	Used to search a reconciliation associated with a payment tender which is received through a particular check.  <b>Note:</b> This field appears only when you select the <b>Payment Tender Details</b> option from the <b>Search By</b> list.	No
Payor Account ID	Used to search reconciliations which are associated with a particular payor account.  <b>Note:</b> This field appears only when you select the <b>Payment Tender Details</b> option from the <b>Search By</b> list.	No
MICR ID	Used to search a reconciliation associated with a payment tender which contains a particular MICR code.  <b>Note:</b> This field appears only when you select the <b>Payment Tender Details</b> option from the <b>Search By</b> list.	No
Tender Amount	Used to search reconciliations associated with payment tenders with a particular amount.  <b>Note:</b> This field appears only when you select the <b>Payment Tender Details</b> option from the <b>Search By</b> list.	No

**Note:** You must specify at least one search criterion while searching for a reconciliation.

- **Search Results** - On clicking the **Search** button, the search results appear based on the specified search criteria. The **Search Results** section contains the following columns:

Column Name	Column Description
Creation Date Time	Displays the date and time when the reconciliation is created in the system.
Reconciliation Information	Displays information about the reconciliation.  <b>Note:</b> It has a link. On clicking the link, the <b>Reconciliation</b> screen appears where you can view the details of the respective reconciliation.

Column Name	Column Description
Status	Indicates the status of the reconciliation. The valid values are: <ul style="list-style-type: none"> <li>• Canceled</li> <li>• Completed</li> <li>• Draft</li> <li>• Initial Reconciliation in Progress</li> <li>• Open</li> <li>• Pending Cancelation</li> <li>• Pending</li> <li>• Pending Reconciliation</li> <li>• Reconciliation in Progress</li> </ul>
Payor Account ID	Indicates the payor account to which the reconciliation is associated.  <b>Note:</b> It has a link. On clicking the link, the <b>Account</b> screen appears where you can view the details of the respective payor account.
Payment ID	Indicates the payment to which the reconciliation is associated.  <b>Note:</b> It has a link. On clicking the link, the <b>Payment</b> screen appears where you can view the details of the respective payment.
File Name	Indicates the pay instruction file for which the reconciliation is created in the system.
Duplicate	Used to create a new reconciliation using an existing reconciliation.  <b>Note:</b> The <b>Duplicate</b> button appears only when the reconciliation is in the <b>Canceled</b> status.

### **Related Topics**

For more information on...	See...
How to search for a reconciliation	<a href="#">Searching for a Reconciliation</a> on page 2246
How to view the details of a reconciliation	<a href="#">Viewing the Reconciliation Details</a> on page 2247

## **Searching for a Reconciliation**

### **Prerequisite**

To search for a reconciliation, you should have:

- Reconciliation types and account identifier types defined in the application.

### **Procedure**

To search for a reconciliation:

1. Click the **Menu** link in the **Application** toolbar.  
A list appears.
2. From the **Main** menu, select **Financial** and then click **Reconciliation**.

The **Reconciliation** screen appears.

3. Enter the search criteria in the **Search Reconciliation** zone.

**Note:** ORMB search engine supports wildcard search, where you can substitute the percentage (%) symbol as a stand in for any word or letter in a search criteria. You can use the ‘%’ wildcard character in all input fields except the date and ID fields. The ‘%’ wildcard character is suffixed automatically at the end of the partial search criteria. Therefore, you may or may not specify the wildcard character at the end of the partial search criteria. However, you have to prefix the wildcard character manually wherever required.

4. Click **Search**.

A list of reconciliations that meet the search criteria appears in the **Search Results** section.

#### **Related Topics**

<b>For more information on...</b>	<b>See...</b>
<b>Reconciliation</b> screen	<a href="#">Reconciliation (Used for Searching)</a> on page 2243
<b>Search Reconciliation</b> zone	<a href="#">Search Reconciliation</a> on page 2243

## **Viewing the Reconciliation Details**

### **Procedure**

To view the details of a reconciliation:

1. Search for the reconciliation in the **Reconciliation** screen.
2. In the **Search Results** section, click the link in the **Reconciliation Information** column corresponding to the reconciliation whose details you want to view.  
The **Reconciliation** screen appears.
3. Ensure that the **Main** tab is selected.
4. View the details of the reconciliation in the **Reconciliation** zone.
5. View the list of pay instructions uploaded through the file in the **Pay Instructions** zone.

### **Related Topics**

<b>For more information on...</b>	<b>See...</b>
How to search for a reconciliation	<a href="#">Searching for a Reconciliation</a> on page 2246
<b>Reconciliation</b> screen	<a href="#">Reconciliation (Used for Viewing)</a> on page 2247
<b>Reconciliation</b> zone	<a href="#">Reconciliation</a> on page 2248
<b>Pay Instructions</b> zone	<a href="#">Pay Instructions</a> on page 2250

## **Reconciliation (Used for Viewing)**

The **Reconciliation** screen allows you to:

- View the details and characteristics of the reconciliation
- Edit and delete the details of the reconciliation
- Submit the file for reconciliation
- View the pay instructions for reconciliation

- Cancel the pending reconciliation

This screen contains the following tabs:

- [Reconciliation - Main](#) on page 2248
- [Reconciliation - Log](#) on page 2251

For more information on...	See...
How to view the details of reconciliation	<a href="#">Viewing the Reconciliation Details</a> on page 2247
How to edit the details of reconciliation	<a href="#">Editing a Reconciliation Type</a> on page 2239
<b>Reconciliation - Main</b> screen	<a href="#">Reconciliation (Used for Viewing)</a> on page 2247
<b>Reconciliation - Main</b> zone	<a href="#">Reconciliation</a> on page 2248

## Reconciliation - Main

The **Main** tab displays information about the reconciliation. It contains the following zones:

- [Reconciliation](#) on page 2248
- [Pay Instructions](#) on page 2250

### Reconciliation

The **Reconciliation** zone displays the details of the reconciliation. It contains the following sections:

- **Main** - Displays basic information about the reconciliation. It contains the following fields:

Field Name	Field Description
Reconciliation Information	Displays information about the reconciliation.
Reconciliation Type	Indicates the reconciliation type using which the reconciliation is created.  <b>Note:</b> It has a link. On clicking the link, the <b>Reconciliation Type</b> screen appears where you can view the details of the reconciliation type.
Status	Indicates the status of the reconciliation. The valid values are: <ul style="list-style-type: none"> <li>• Canceled</li> <li>• Completed</li> <li>• Draft</li> <li>• Initial Reconciliation in Progress</li> <li>• Open</li> <li>• Pending Cancellation</li> <li>• Pending</li> <li>• Pending Reconciliation</li> <li>• Reconciliation in Progress</li> </ul>
Status Reason	Indicates the reason why the status of the reconciliation is changed.  <b>Note:</b> This field appears only when the reconciliation is in the <b>Pending Cancellation</b> or <b>Canceled</b> status.



Field Name	Field Description
File Name	Indicates the pay instruction file for which the reconciliation is created in the system.
Payment Information	Indicates the payment to which the reconciliation is associated. In addition, a context menu appears corresponding to this field which helps in navigating to other screens in the application.  <div style="border: 1px solid black; padding: 5px;"> <p><b>Note:</b> It has a link. On clicking the link, the <b>Payment</b> screen appears where you can view the details of the respective payment. This field does not appear when the reconciliation is in the <b>Draft</b> or <b>Pending</b> status.</p> </div>
Account Information	Indicates the payor account to which the reconciliation is associated.  <div style="border: 1px solid black; padding: 5px;"> <p><b>Note:</b> This field does not appear when the reconciliation is in the <b>Draft</b> or <b>Pending</b> status.</p> </div>

- **Characteristics** - Lists the characteristics defined for the reconciliation. It contains the following columns:

Column Name	Column Description
Effective Date	Displays the date from when the characteristic is effective for the reconciliation.
Characteristic Type	Indicates the characteristic type.
Characteristic Value	Displays the value of the characteristic type.
Description	Displays the description of the characteristic value.  <div style="border: 1px solid black; padding: 5px;"> <p><b>Note:</b> The data appears in this column only when the type of characteristic value is set to <b>Predefined Value</b> or <b>Foreign Key Value</b>.</p> </div>

- **Record Actions** - This section contains the following buttons:

Button Name	Button Description
Edit	Used to edit the details of the reconciliation.  <div style="border: 1px solid black; padding: 5px;"> <p><b>Note:</b> The <b>Edit</b> button appears only when the reconciliation is in the <b>Pending</b> or <b>Draft</b> status.</p> </div>
Delete	Used to delete the reconciliation.  <div style="border: 1px solid black; padding: 5px;"> <p><b>Note:</b> The <b>Delete</b> button appears only when the reconciliation is in the <b>Pending</b> or <b>Draft</b> status.</p> </div>
Submit for Reconciliation	Used to submit the pay instructions for reconciliation.  <div style="border: 1px solid black; padding: 5px;"> <p><b>Note:</b> The <b>Submit for Reconciliation</b> button appears only when the reconciliation is in the <b>Pending</b> status.</p> </div>

Button Name	Button Description
Cancel	Used to cancel the reconciliation.  <b>Note:</b> The <b>Cancel</b> button appears only when the reconciliation is in the <b>Completed</b> or <b>Open</b> status.
Reconcile	Used to reconcile the pay instructions in the reconciliation.  <b>Note:</b> The <b>Reconcile</b> button appears only when the reconciliation is in the <b>Pending Reconciliation</b> status.
Revert to Pending	Used to revert the status of the reconciliation to <b>Pending</b> .  <b>Note:</b> The <b>Revert to Pending</b> button appears only when the reconciliation is in the <b>Pending Reconciliation</b> status.

- **Record Information** - This section contains the following fields:

Field Name	Field Description
Business Object	Indicates the business object using which the reconciliation is created. In addition, a context menu appears corresponding to this field which helps in navigating to other screens in the application.  <b>Note:</b> It has a link. On clicking the link, the <b>Business Object</b> screen appears where you can view the details of the respective business object.
Status Date Time	Displays the date and time when the reconciliation status is updated.
Creation Date Time	Displays the date and time when the reconciliation is created.

### Pay Instructions

The **Pay Instructions** zone lists the pay instructions that are received from an external system against the bill segment based on the account identifier, policy number, plan number, member identifier, and coverage period combination. It contains the following columns:

Column Name	Column Description
Sequence No.	Displays a sequential number against each record.
View Payment Instruction	On clicking the <b>View Payment Instruction</b> (🔍) icon, <b>Pay Instruction</b> screen appears where entire pay instruction details are displayed.
Account Identifier Type	Indicates the account identifier type.
Account Identifier	Displays the value of the account identifier type.
Account ID	Displays the account ID.  <b>Note:</b> It has a link. On clicking the link, the <b>Account</b> screen appears with the details of the respective account.
Policy Number	Displays the policy number of the member.
Plan Number	Displays the plan number of the member.
Member Identifier Type	Indicates the member identifier type.

Column Name	Column Description
Member Identifier	Displays the value of the member identifier type.
Member Name	Displays the name of the member.
Coverage Start Date	Displays the date from when the coverage is effective.
Coverage End Date	Displays the date till when the coverage is effective.
Amount	Indicates the amount that has to be paid to the member.
Open Amount	Indicates the amount which has not been paid to the member and is still in the open state.
Status	Indicates the status of the pay instruction. The valid values are: <ul style="list-style-type: none"> <li>• Cancelled</li> <li>• Completed</li> <li>• Draft</li> <li>• Initial Reconciliation In Progress</li> <li>• Open</li> <li>• Pending Cancellation</li> <li>• Pending</li> <li>• Pending Reconciliation</li> <li>• Reconciliation In Progress</li> </ul>
Pay Instruction ID	Displays the pay instruction ID.

**Note:** You can use the **Previous** and **Next** links to scroll through the pay instructions item list.

## Reconciliation - Log

The **Log** tab contains the following zone:

- [Reconciliation Log](#) on page 2251

### Reconciliation Log

The **Reconciliation Log** zone lists the complete trail of actions performed on the reconciliation. It contains the following columns:

Column Name	Column Description
Creation Date Time	Displays the date and time when the action was performed on the reconciliation.
Details	Displays the details about the action performed on the reconciliation.
User	Indicates the user who has performed the action on the reconciliation.
Log Type	Indicates the type of the log.
Related Object	Indicates the object or entity that is created when the action is performed on the reconciliation.

Column Name	Column Description
Status Reason	Indicates the reason why the status of the reconciliation is changed.  <b>Note:</b> The data appears in this column only when the status of the reconciliation is changed to <b>Pending Cancelation</b> or <b>Canceled</b> .

**Note:** You can manually add a log entry for the reconciliation by clicking the **Add Log Entry** link in the upper right corner of the **Reconciliation Log** zone.

### Related Topics

For more information on...	See...
How to view the log of a reconciliation	<a href="#">Viewing the Log of a Reconciliation</a> on page 2256
How to add a log entry for a reconciliation	<a href="#">Adding a Log Entry for a Reconciliation</a> on page 2256

## Editing a Reconciliation

### Procedure

To edit a reconciliation:

1. Search for the reconciliation in **Reconciliation** screen.  
A list appears.
2. In the **Search Results** section, click the link in the **Reconciliation Information** column corresponding to the reconciliation whose details you want to edit.  
The **Reconciliation** screen appears.
3. Click the **Edit** button in the **Reconciliation** zone.  
The **Member Reconciliation** screen appears.

**Note:** The **Edit** button appears only when the reconciliation is in the **Pending** status.

**Note:** ORMB search engine supports wildcard search, where you can substitute the percentage (%) symbol as a stand in for any word or letter in a search criteria. You can use the ‘%’ wildcard character in all input fields except the date and ID fields. The ‘%’ wildcard character is suffixed automatically at the end of the partial search criteria. Therefore, you may or may not specify the wildcard character at the end of the partial search criteria. However, you have to prefix the wildcard character manually wherever required.

4. Define, edit, or remove characteristics from the reconciliation, if required.
5. Click **Save**.

The changes made to the reconciliation are saved.

### Related Topics

For more information on...	See...
How to search for a reconciliation	<a href="#">Searching for a Reconciliation</a> on page 2246

## Defining Characteristics for a Reconciliation

### Prerequisites

To define characteristics for a reconciliation, you should have:

- Characteristic Type defined in the application (where the characteristic entity is set to **Reconciliation**)

### **Procedure**

To define characteristics for a reconciliation:

1. Ensure that the **Characteristics** section is expanded when you are editing a reconciliation.

The **Characteristics** section contains the following fields:

2. Enter the required details in the **Characteristics** section.

**Note:** If you select a predefined characteristic type, the **Search** (🔍) icon appears corresponding to the **Characteristic Value** field. On clicking the **Search** icon, you can search for a predefined characteristic value.

The **Reconciliation** screen appears.

3. If you want to define more than one characteristic for the reconciliation, click the **Add** (+) icon and then repeat step 2.

**Note:** However, if you want to remove a characteristic from the reconciliation, click the **Delete** (🗑️) icon corresponding to the characteristic.

**Note:** ORMB search engine supports wildcard search, where you can substitute the percentage (%) symbol as a stand in for any word or letter in a search criteria. You can use the '%' wildcard character in all input fields except the date and ID fields. The '%' wildcard character is suffixed automatically at the end of the partial search criteria. Therefore, you may or may not specify the wildcard character at the end of the partial search criteria. However, you have to prefix the wildcard character manually wherever required.

4. Click **Search**.

A list of reconciliation files that meet the search criteria appear in the **Search Results** section.

5. In the **Search Results** section, click the link in the **Reconciliation Information** column corresponding to the status column.

The **Reconciliation** screen appears.

6. Click **Edit** button from **Record Actions** section.

The **Member Reconciliation** screen appears. It contains the following sections:

- **Main** - Used to specify the basic details of the reconciliation.
- **Characteristics** - Used to specify the characteristics for the reconciliation. It contains the following fields:

Field Name	Field Description	Mandatory (Yes or No)
Effective Date	Used to specify the date from when the characteristic is effective for the reconciliation.	Yes
Characteristic Type	Used to indicate the characteristic type. <b>Note:</b> The list includes only those characteristic types where the characteristic entity is set to <b>Reconciliation</b> .	Yes

Field Name	Field Description	Mandatory (Yes or No)
Characteristic Value	Used to specify the value for the characteristic type.  <b>Note:</b> On specifying the value for a predefined characteristic type, the description of the characteristic value appears corresponding to the <b>Characteristic Value</b> field.	Yes

### Related Topics

For more information on...	See...
How to edit an reconciliation	<a href="#">Editing a Reconciliation</a> on page 2252

## Deleting a Reconciliation

### Procedure

To delete a reconciliation:

1. Search for the reconciliation in the **Reconciliation** screen.

**Note:** ORMB search engine supports wildcard search, where you can substitute the percentage (%) symbol as a stand in for any word or letter in a search criteria. You can use the ‘%’ wildcard character in all input fields except the date and ID fields. The ‘%’ wildcard character is suffixed automatically at the end of the partial search criteria. Therefore, you may or may not specify the wildcard character at the end of the partial search criteria. However, you have to prefix the wildcard character manually wherever required.

2. In the **Search Results** section, click the link in the **Reconciliation Information** column corresponding to the reconciliation that you want to delete.

The **Reconciliation** screen appears.

3. Click the **Delete** button in the **Reconciliation** zone.

A message appears confirming whether you want to delete the reconciliation.

**Note:** The **Delete** button appears only when the reconciliation is in the **Pending** or **Draft** status.

4. Click **OK**.

The reconciliation object is deleted.

### Related Topics

For more information on...	See...
<b>Search Reconciliation</b> screen	<a href="#">Reconciliation (Used for Searching)</a> on page 2243
<b>Search Reconciliation</b> zone	<a href="#">Search Reconciliation</a> on page 2243
How to search for a reconciliation	<a href="#">Searching for a Reconciliation</a> on page 2246

## Submitting Pay Instructions for a Reconciliation

### Prerequisites

To submit pay instructions for reconciliation, you should have:

- Account ID defined in the application.
- Reconciliation BO status as Pending.

## Procedure

To submit pay instructions for a reconciliation:

1. Search for the reconciliation in the **Reconciliation** screen.

**Note:** ORMB search engine supports wildcard search, where you can substitute the percentage (%) symbol as a stand in for any word or letter in a search criteria. You can use the ‘%’ wildcard character in all input fields except the date and ID fields. The ‘%’ wildcard character is suffixed automatically at the end of the partial search criteria. Therefore, you may or may not specify the wildcard character at the end of the partial search criteria. However, you have to prefix the wildcard character manually wherever required.

2. In the **Search Results** section, click the link in the **Reconciliation Information** column corresponding to the reconciliation that you want to submit.

The **Reconciliation** screen appears.

3. Click the **Submit for Reconciliation** button in the **Reconciliation** zone.

The pay instruction is submitted for reconciliation and the reconciliation status gets changed to **Pending Reconciliation**.

**Note:**

The **Submit for Reconciliation** button appears only when the reconciliation is in the **Pending** status.

## Related Topics

For more information on...	See...
How to search a reconciliation	<a href="#">Searching for a Reconciliation</a> on page 2246

## Reconciling Pay Instructions

### Prerequisites

To reconcile pay instructions, you should have:

- Account ID defined in the application.
- Reconciliation BO Status must be in Pending Reconciliation.

### Procedure

To reconcile pay instructions:

1. Search for the reconciliation in the **Reconciliation** screen.

**Note:** ORMB search engine supports wildcard search, where you can substitute the percentage (%) symbol as a stand in for any word or letter in a search criteria. You can use the ‘%’ wildcard character in all input fields except the date and ID fields. The ‘%’ wildcard character is suffixed automatically at the end of the partial search criteria. Therefore, you may or may not specify the wildcard character at the end of the partial search criteria. However, you have to prefix the wildcard character manually wherever required.

2. In the **Search Results** section, click the link in the **Reconciliation Information** column corresponding to the reconciliation that you want to reconcile.

The **Reconciliation** screen appears.

3. Click the **Reconcile** button in the **Reconciliation** zone.

The pay instructions gets reconciled and the reconciliation BO status gets changed to **Completed**.

**Note:**

The **Reconcile** button appears only when the reconciliation is in the **Pending Reconciliation** status.

**Related Topics**

For more information on...	See...
How to search for a reconciliation	<a href="#">Searching for a Reconciliation</a> on page 2246

**Adding a Log Entry for a Reconciliation****Procedure**

To add a log entry for a reconciliation:

1. Search for the reconciliation in the **Reconciliation** screen.
2. In the **Search Results** section, click the link in the **Reconciliation Information** column corresponding to the reconciliation whose log you want to edit.

The **Reconciliation** screen appears.

3. Click the **Log** tab.

The **Log** tab appears.

4. Click the **Add Log Entry** link in the upper right corner of the **Reconciliation Log** zone.

The **Add Reconciliation Log** window appears. It contains the following fields:

Field Name	Field Description	Mandatory (Yes or No)
Reconciliation Information	Displays information about the reconciliation.	Not applicable
Log Details	Used to specify additional comments on the reconciliation.	Yes

5. Enter the comments in the **Log Details** field.

6. Click **Save**.

The log entry is added in the **Reconciliation Log** zone.

**Related Topics**

For more information on...	See...
How to search for a reconciliation	<a href="#">Searching for a Reconciliation</a> on page 2246
<b>Reconciliation</b> screen	<a href="#">Reconciliation (Used for Viewing)</a> on page 2247
<b>Reconciliation Log</b> zone	<a href="#">Reconciliation Log</a> on page 2251

**Viewing the Log of a Reconciliation****Procedure**

To view the log of a reconciliation:

1. Search for the reconciliation in the **Reconciliation** screen.
2. In the **Search Results** section, click the link in the **Reconciliation Information** column corresponding to the reconciliation whose log you want to view.



The **Reconciliation** screen appears.

3. Click the **Log** tab.

The **Log** tab appears.

4. View the complete trail of actions performed on the reconciliation in the **Reconciliation Log** zone.

### Related Topics

For more information on...	See...
How to search for a reconciliation	<a href="#">Searching for a Reconciliation</a> on page 2246
How to add a log entry for a reconciliation	<a href="#">Adding a Log Entry for a Reconciliation</a> on page 2256
<b>Reconciliation</b> screen	<a href="#">Reconciliation (Used for Viewing)</a> on page 2247
<b>Reconciliation Log</b> zone	<a href="#">Reconciliation Log</a> on page 2251

## Canceling a Reconciliation

### Prerequisites

To cancel a reconciliation, you should have:

- Cancellation reasons defined in the application.

**Note:** While cancelling a reconciliation, you need to specify the reason why you want to cancel the reconciliation. You can select the appropriate cancellation reason only when you have defined the reasons for the **Canceled** status of the **C1-MemberReconciliation** business object in the **Status Reason** screen.

### Procedure

To cancel a reconciliation:

1. Search for the reconciliation in the **Reconciliation** screen.
2. In the **Search Results** section, click the link in the **Reconciliation Information** column corresponding to the reconciliation that you want to cancel.

The **Reconciliation** screen appears.

- [Reconciliation - Main](#) on page 2248
- [Reconciliation - Log](#) on page 2251

3. Click the **Cancel** button in the **Reconciliation** zone.

The **Status Reason** window appears. It contains following field:

:

Field Name	Field Description	Mandatory (Yes or No)
Status Reason	Used to indicate the reason why you want to cancel the reconciliation.	Yes

**Note:** The **Cancel** button appears only when the reconciliation is in the **Open** or **Completed** status.

4. Select the cancellation status reason from the **Status Reason** list.
5. Click **Save**.

The status of the reconciliation is changed to **Cancelled**.

**Related Topics**

For more information on...	See...
How to search for a reconciliation	<a href="#">Searching for a Reconciliation</a> on page 2246
<b>Reconciliation</b> screen	<a href="#">Reconciliation (Used for Viewing)</a> on page 2247
<b>Reconciliation</b> zone	<a href="#">Reconciliation</a> on page 2248
How to view details of reconciliation	<a href="#">Viewing the Reconciliation Details</a> on page 2247

**Viewing the Pay Instruction Details****Procedure**

To view the details of a pay instruction:

1. Search for reconciliation information in the **Reconciliation** screen.
2. In the **Search Results** section, click the link in the **Reconciliation Information** column corresponding to the reconciliation whose pay instruction details you want to view.  
The **Reconciliation** screen appears.
3. The **Reconciliation** screen consists of the following tabs:
  - [Reconciliation - Main](#) on page 2248
  - [Reconciliation - Log](#) on page 2251
4. The **Main** tab displays information about the reconciliation.
5. In the **Pay Instructions** zone, click the **Go To Payment Instruction** (🔗) icon corresponding to the pay instruction whose details you want to view.  
The **Pay Instruction** screen appears.
6. View the details of the pay instruction in the **Pay Instruction** screen.

**Related Topics**

For more information on...	See...
Searching for a Reconciliation	<a href="#">Searching for a Reconciliation</a> on page 2246
<b>Reconciliation</b> screen	<a href="#">Reconciliation (Used for Viewing)</a> on page 2247
<b>Reconciliation - Main</b> zone	<a href="#">Reconciliation - Main</a> on page 2248
<b>Pay Instructions</b> zone	<a href="#">Pay Instruction</a>
<b>Pay Instructions</b> screen	<a href="#">Pay Instruction</a> on page 2258

**Pay Instruction**

The **Pay Instruction** screen displays detailed information of a pay instruction which is the part of reconciliation:

- View the details and characteristics of the pay instruction
- View the details of the reconciliation adjustments
- View the related objects

This screen contains of the following tabs:

- [Pay Instruction - Main](#) on page 2259
- [Pay Instruction - Log](#) on page 2260

## Pay Instruction - Main

The **Pay Instruction - Main** tab displays information about the pay instruction. It contains the following zones:

- [Pay Instruction](#)
- [Reconciliation Adjustments](#) on page 2259
- [Related Objects](#) on page 2260

### Pay Instruction

The **Pay Instruction - Main** tab consists of the following zones:

- **Pay Instruction**
- **Reconciliation Adjustments**
- **Related Object**

### Related Topics

For more information on...	See...
<b>Pay Instruction - Main</b> zone	<a href="#">Pay Instruction</a>
<b>Reconciliation Adjustments</b> zone	<a href="#">Reconciliation Adjustments</a> on page 2259
<b>Related Objects</b> zone	<a href="#">Related Objects</a> on page 2260

### Reconciliation Adjustments

The **Reconciliation Adjustments** zone displays the adjustment information for each pay instruction. It contains the following fields:

Column Name	Column Description
Transfer Adjustment	Indicates the amount to be transferred from a reconciliation contract against a pay instruction.  <b>Note:</b> It has a link. On clicking the link, the <b>Adjustment</b> screen appears where you can view the details of the transferred adjustment.
Transfer Type	Displays the type of transfer transaction made against a pay instruction or an internal offsetting.
Transfer Financial Transaction ID	Displays the transfer financial transaction ID.
Offset Adjustment	Indicates a reciprocal adjustment that is associated with a transfer adjustment.  <b>Note:</b> It has a link. On clicking the link, the <b>Adjustment</b> screen appears where you can view the offset adjustment details.
Related Object Type	Displays the related object type whether it is pay instruction / financial transaction.

Column Name	Column Description
Related Object ID	Indicates the ID of the related pay instruction / financial transaction created in reconciliation process..  <b>Note:</b> It has a link. On clicking the link, the <b>Financial Transaction</b> screen appears where you can view the details of the financial transaction of reconciliation adjustments.

**Note:** Pagination is used to display limited number of records in the **Reconciliation Adjustments** zone. By default, 10 records are displayed in this zone. You can use the navigation links, such as Previous and Next to navigate between pages.

You can filter the adjustments using **Show All Adjustments** available in the **Filter** area. By default, the **Filter** area is hidden. You can view the **Filter** area by clicking the **Filters** (  ) icon in the upper right corner of the **Reconciliation Adjustments** zone.

### Related Objects

The **Related Objects** zone displays all those business objects based on which reconciliation process takes place. It contains the following fields:

Column Name	Column Description
Related Object Type	Displays the related object type that was used in pay instruction process.
Related Object Information	Displays the details of related object in brief.

**Note:** Pagination is used to display limited number of records in the **Related Topics** zone. By default, 10 records are displayed in this zone. You can use the navigation links, such as Previous and Next to navigate between pages.

### Pay Instruction - Log

The **Pay Instruction - Log** tab contains the following zone:

- [Pay Instruction Log](#) on page 2260

### Pay Instruction Log

The **Pay Instruction Log** zone lists the complete trail of actions performed on the pay instructions. It contains the following columns:

Column Name	Column Description
Creation Date Time	Displays the date and time when the action was performed on the pay instruction.
Details	Displays the details about the action performed on the pay instruction.
User	Indicates the user who has performed the action on the pay instruction.
Log Type	Indicates the type of log.
Related Object	Indicates the object or entity which is generated when the action is performed on the pay instruction.
Status Reason	Displays the status reason of action performed on the pay instruction.

**Note:** You can manually add a log entry for the pay instruction by clicking the **Add Log Entry** link in the upper right corner of the **Pay Instruction Log** zone.

**Related Topics**

For more information on...	See...
How to view the log of a pay instruction	<a href="#">Viewing the Log of a Pay Instruction</a> on page 2261
How to add a log entry for a pay instruction	<a href="#">Adding a Log Entry for a Pay Instruction</a> on page 2261

**Adding a Log Entry for a Pay Instruction****Procedure**

To add a log entry for a pay instruction:

1. Search for the reconciliation in the **Reconciliation** screen.
2. In the **Search Results** section, click the link in the **Reconciliation Information** column corresponding to the reconciliation whose pay instruction log you want to edit.

The **Reconciliation** screen is displayed.

3. In the **Pay Instructions** zone of the **Main**, click the Go To icon () corresponding to the pay instruction whose log you want to edit.

The **Pay Instruction** screen appears. It consists of the following tabs:

- [Pay Instruction - Main](#) on page 2259
- [Pay Instruction - Log](#) on page 2260

4. Click the **Log** tab.

The **Pay Instruction** screen appears.

5. Click the **Add Log Entry** link in the upper right corner of the **Pay Instruction Log** zone.

The **Add Pay Instruction Log** screen appears. It contains the following fields:

Field Name	Field Description	Mandatory (Yes or No)
Pay Instruction Information	Displays information about the pay instruction.	Not applicable
Log Details	Used to specify additional comments for the pay instruction.	Yes

6. Enter the comments in the **Log Details** field.
7. Click **Save**.

The log entry is added in the **Pay Instruction Log** zone.

**Related Topics**

For more information on...	See...
How to search for a reconciliation	<a href="#">Searching for a Reconciliation</a> on page 2246

**Viewing the Log of a Pay Instruction****Procedure**

To view the log of a Pay Instruction:

1. Search for the reconciliation information in the **Reconciliation** screen.

- In the **Search Results** section, click the link in the **Reconciliation Information** column corresponding to the reconciliation, whose pay instruction log you want to view.

The **Reconciliation** screen appears.

- In the **Pay Instructions** zone of the **Main**, click the **Go To Payment Instruction** () icon, corresponding to the pay instruction whose log you want to view.

The **Pay Instruction** screen appears. It consists of the following tabs:

- [Pay Instruction - Main](#) on page 2259
- [Pay Instruction - Log](#) on page 2260

- Click the **Log** tab.

The **Log** tab appears.

- View the complete trail of actions performed on the pay instruction in the **Pay Instruction Log** zone.

### Related Topics

For more information on...	See...
How to add a log entry for a pay instruction	<a href="#">Adding a Log Entry for a Pay Instruction</a> on page 2261
<b>Pay Instruction</b> screen	<a href="#">Pay Instruction</a> on page 2258
<b>Pay Instruction Log</b> zone	<a href="#">Pay Instruction Log</a> on page 2260

## Discrepancy Report Type

Oracle Revenue Management and Billing allows you to define a discrepancy report type using which you can create a discrepancy report. The Discrepancy Report Type uses the following business object.

- **C1-DiscrepancyReport**

The **Discrepancy Report Type** screen allows you to define, edit, copy, and delete a discrepancy report type. It consists of the following zones:

- [Discrepancy Report Type List](#) on page 2262
- [Discrepancy Report Type](#) on page 2263

For more information on...	See...
How to define a discrepancy report type	<a href="#">Defining a Discrepancy Report Type</a> on page 2264

### Discrepancy Report Type List

The **Discrepancy Report Type List** zone lists the various types of discrepancy report types. It contains the following columns:

Column Name	Column Description
Discrepancy Report Type	Displays the discrepancy report type.
Description	Displays the description of the discrepancy report type.
Edit	On clicking the <b>Edit</b> (  ) icon, the <b>Discrepancy Report Type</b> screen appears where you can edit the details of the discrepancy report type.

Column Name	Column Description
Duplicate	On clicking the <b>Duplicate</b> (  ) icon, the <b>Discrepancy Report Type</b> screen appears where you can define a discrepancy report type using an existing discrepancy report type.
Delete	On clicking the <b>Delete</b> (  ) icon, you can delete the discrepancy report type.  <b>Note:</b> You can delete a discrepancy report type only when you have not created a discrepancy report using the discrepancy report type.

On clicking the **Broadcast** () icon corresponding to a discrepancy report type, the **Discrepancy Report Type** zone appears with the details of the respective discrepancy report type.

### Related Topics

For more information on...	See...
How to view the details of discrepancy report type	<a href="#">Viewing the Discrepancy Report Type Details</a> on page 2270
How to edit the details of discrepancy report type	<a href="#">Editing a Discrepancy Report Type</a> on page 2267
How to delete the discrepancy report type	<a href="#">Deleting a Discrepancy Report Type</a> on page 2268
How to copy the discrepancy report type	<a href="#">Copying a Discrepancy Report Type</a> on page 2268

## Discrepancy Report Type

The **Discrepancy Report Type** zone displays the details of the discrepancy report type. It consists of the following sections:

- **Main** - This section provides basic information about the discrepancy report type. It contains the following fields:

Field Name	Field Description
Discrepancy Report Type	Displays the discrepancy report type.
Discrepancy Report Business Object	Indicates the business object using which the discrepancy report will be created. In addition, a context menu appears corresponding to this field which helps in navigating to other screens in the application.  <b>Note:</b> It has a link. On clicking the link, the <b>Business Object</b> screen appears where you can view the details of the respective business object.
Description	Displays the description of the discrepancy report type.
Detailed Description	Displays additional information about the discrepancy report type.
Status	Indicates the status of the inbound message type. The valid values are: <ul style="list-style-type: none"> <li>• Active</li> <li>• Inactive</li> </ul>

- **Characteristics** - This section lists the characteristics defined for the discrepancy report type. It contains the following columns:.

Column Name	Column Description
Characteristic Type	Indicates the characteristic type.  <b>Note:</b> The list includes only those characteristic types where the characteristic entity is set to Discrepancy Report Type.
Characteristic Value	Displays the value of the characteristic type.  <b>Note:</b> On specifying the value for a predefined characteristic type, the description of the characteristic value appears corresponding to the Characteristic Value field.
Description	Displays detailed description of the characteristic type.

- **Record Actions** - This section contains the following buttons:

Button Name	Button Description
Edit	Used to edit the details of the discrepancy report type.
Delete	Used to delete the discrepancy report type.  <b>Note:</b> You can delete a discrepancy report type only when you have not created a discrepancy report using the discrepancy report type.
Duplicate	Used to create a new discrepancy report type using an existing discrepancy report type.

- **Record Information** - This section contains the following fields:

Field Name	Field Description
Business Object	Indicates the business object using which the discrepancy report type is created. In addition, a context menu appears corresponding to this field which helps in navigating to other screens in the application.  <b>Note:</b> It has a link. On clicking the link, the <b>Business Object</b> screen appears where you can view the details of the respective business object.

By default, the **Discrepancy Report Type** zone does not appear in the **Discrepancy Report Type** screen. It appears only when you click the **Broadcast**  icon corresponding to a discrepancy report type in the **Discrepancy Report Type List** zone.

### Related Topics

For more information on...	See...
How to view the details of discrepancy report type	<a href="#">Viewing the Discrepancy Report Type Details</a> on page 2270

## Defining a Discrepancy Report Type

### Prerequisites

To define a discrepancy report type, you should have:

- **C1-DiscrepancyReport** Business object defined for discrepancy report.



- Characteristic Type defined for the discrepancy report.

### **Procedure**

To define a discrepancy report type:

1. Click the **Admin** link in the **Application** toolbar.  
A list appears.
2. From the **Admin** menu, select **D**, and then click **Discrepancy Report Type**.  
The sub-menu appears.
3. Click the **Add** option from the **Discrepancy Report Type**.

The **Select Business Object** screen appears. It contains the following field:

Field Name	Field Description	Mandatory (Yes or No)
Discrepancy Report Type Business Object	Indicates the discrepancy report type business object used to create a discrepancy report type.	Yes

**Tip:** Alternatively, you can access the **Select Business Object** screen by clicking the **Add** button in the **Page Title** area of the **Discrepancy Report Type** screen.

**Note:** The **Select Business Object** screen appears only when there are multiple discrepancy report type business objects defined in the application. If there is only one discrepancy report type business object defined in the application, the **Discrepancy Report Type** screen appears.

4. Select the business object depending on whether you want to create a discrepancy report type.
5. Click **OK**.

The **Discrepancy Report Type** screen appears. It contains the following sections:

- **Main** - Used to specify basic details about the discrepancy report type.
- **Characteristics** - Used to define characteristics for the discrepancy report type.

The **Main** section contains the following fields:

Field Name	Field Description	Mandatory (Yes or No)
Discrepancy Report Type	Used to specify the discrepancy report type.	Yes
Business Object	Indicates the discrepancy report type business object using which you are defining the discrepancy report type	Not applicable
Discrepancy Report Business Object	Used to indicate the business object using which you want to create the discrepancy report.	Yes
Description	Used to specify the description for the discrepancy report type.	Yes
Detailed Description	Used to specify additional information about the discrepancy report type.	No
Status	Used to indicate the status of the discrepancy report type. The valid values are: <ul style="list-style-type: none"> <li>• Active</li> <li>• Inactive</li> </ul>	Yes

6. Enter the required details in the **Main** section.
7. Define characteristics for the discrepancy report type, if required.
8. Click **Save**.

The discrepancy report type is defined.

### Related Topics

For more information on...	See...
<b>Discrepancy Report Type List</b> zone	<a href="#">Discrepancy Report Type List</a> on page 2262
<b>Discrepancy Report Type</b> zone	<a href="#">Discrepancy Report Type</a> on page 2263

## Defining Characteristics for a Discrepancy Report Type

### Prerequisites

To define characteristics for a discrepancy report type, you should have:

- Characteristic Types defined in the application (where the characteristic entity is set to **Discrepancy Report Type**).

### Procedure

To define characteristics for a discrepancy report type:

1. Ensure that the **Characteristics** section is expanded when you are defining, editing, or copying a discrepancy report type.

The **Characteristics** section contains the following fields:

Field Name	Field Description	Mandatory (Yes or No)
Characteristic Type	Used to indicate the characteristic type.  <b>Note:</b> The list includes only those characteristic types where the characteristic entity is set to <b>Discrepancy Report Type</b> .	Yes (Conditional)  <b>Note:</b> This field is required when you are defining a characteristic for the discrepancy report type.
Characteristic Value	Used to specify the value for the characteristic type.  <b>Note:</b> On specifying the value for a predefined characteristic type, the description of the characteristic value appears corresponding to the <b>Characteristic Value</b> field.	Yes (Conditional)  <b>Note:</b> This field is required when you are defining a characteristic for the discrepancy report type.

2. Enter the required details in the **Characteristics** section.

**Note:** If you select a predefined characteristic type, the **Search** (🔍) icon appears corresponding to the **Characteristic Value** field. On clicking the **Search** icon, you can search for a predefined characteristic value.

3. If you want to define more than one characteristic for the discrepancy report type, click the **Add** (+) icon and then repeat step 2.

**Note:** However, if you want to remove a characteristic from the discrepancy report type, click the **Delete** (🗑️) icon corresponding to the characteristic.

### Related Topics

For more information on...	See...
How to edit a discrepancy report type	<a href="#">Editing a Discrepancy Report Type</a> on page 2267
How to copy a discrepancy report type	<a href="#">Copying a Discrepancy Report Type</a> on page 2268

## Editing a Discrepancy Report Type

### Prerequisites

To edit a discrepancy report type, you should have:

- **C1-DiscrepancyReport** Business object defined for discrepancy report.
- Characteristic Type defined for the discrepancy report.

### Procedure

To edit a discrepancy report type:

1. Click the **Admin** link in the **Application** toolbar.  
A list appears.
2. From the **Admin** menu, select **D** and then click **Discrepancy Report Type**.  
A sub-menu appears.
3. Click the **Search** option from the **Discrepancy Report Type** sub-menu.  
The **Discrepancy Report Type** screen appears.
4. In the **Discrepancy Report Type List** zone, click the **Edit** (  ) icon in the **Edit** column corresponding to the discrepancy report type whose details you want to edit.

The **Discrepancy Report Type** screen appears. It contains the following sections:

- **Main** - Used to specify basic details about the discrepancy report type.
- **Characteristics** - Used to define characteristics for the discrepancy report type.

The **Main** section contains the following fields:

Field Name	Field Description	Mandatory (Yes or No)
Discrepancy Report Type	Displays the discrepancy report type.	Not applicable
Business Object	Indicates the discrepancy report type business object used while defining the discrepancy report type.	Not applicable
Discrepancy Report Business Object	Used to indicate the business object using which you want to create the discrepancy report.	Yes
Description	Used to specify the description for the discrepancy report type.	Yes
Detailed Description	Used to specify additional information about the discrepancy report type.	No
Status	Used to indicate the status of the discrepancy report type. The valid values are: <ul style="list-style-type: none"> <li>• Active</li> <li>• Inactive</li> </ul>	No

**Tip:** Alternatively, you can click the **Edit** button in the **Discrepancy Report Type** zone to edit the details of the discrepancy report type.

5. Modify the required details in the **Main** section.
6. Define, edit, or remove characteristics from the discrepancy report type, if required.
7. Click **Save**.

The changes made to the discrepancy report type are saved.

### **Related Topics**

For more information on...	See...
How to define characteristics for a discrepancy report type	<a href="#">Defining Characteristics for a Discrepancy Report Type</a> on page 2266

## **Deleting a Discrepancy Report Type**

### **Procedure**

To delete a discrepancy report type:

1. Click the **Admin** link in the **Application** toolbar.  
A list appears.
2. From the **Admin** menu, select **D** and then click **Discrepancy Report Type**.  
The sub-menu screen appears.
3. Click the **Search** option from the **Discrepancy Report Type** sub-menu.  
The **Discrepancy Report Type** screen appears.
4. In the **Discrepancy Report Type List** zone, click the **Delete** (🗑️) icon corresponding to the discrepancy report type that you want to delete.  
A message appears confirming whether you want to delete the discrepancy report type.

**Note:** You can delete a discrepancy report type only when you have not created a discrepancy report using the discrepancy report type.

**Tip:** Alternatively, you can click the **Delete** button in the **Discrepancy Report Type** zone to delete the discrepancy report type

5. Click **OK** .  
The discrepancy report type is deleted.

### **Related Topics**

For more information on...	See...
<b>Discrepancy Report Type List</b> zone	<a href="#">Discrepancy Report Type List</a> on page 2262

## **Copying a Discrepancy Report Type**

### **Prerequisites**

To copy a discrepancy report type, you should have:

- **C1-DiscrepancyReport** Business object defined for discrepancy report.

- Characteristic Type defined for the discrepancy report.

Instead of creating a discrepancy report type from scratch, you can create a new discrepancy report type using an existing discrepancy report type. This is possible through copying a discrepancy report type. On copying a discrepancy report type, the details including the characteristics are copied to the new discrepancy report type. You can then edit the details, if required.

### **Procedure**

To copy a discrepancy report type:

1. Click the **Admin** link in the **Application** toolbar.  
A list appears.
2. From the **Admin** menu, select **D** and then click **Discrepancy Report Type**.  
The sub-menu appears.
3. Click the **Search** option from the **Discrepancy Report Type** sub-menu.  
The **Discrepancy Report Type** screen appears.
4. In the **Discrepancy Report Type List** zone, click the **Duplicate** () icon in the **Duplicate** column corresponding to the discrepancy report type whose copy you want to create.

The **Discrepancy Report Type** screen appears. It contains the following sections:

- **Main** - The main section contains the following fields:
- **Characteristics** - Used to define characteristics for the discrepancy report type.

The **Main** section contains the following fields:

Field Name	Field Description	Mandatory (Yes or No)
Discrepancy Report Type	Used to specify the discrepancy report type	Not applicable
Business Object	Indicates the discrepancy report type business object using which you are defining the discrepancy report type.	Not applicable
Discrepancy Report Business Object	Used to indicate the business object using which you want to create the discrepancy report.	Yes
Description	Used to specify the description for the discrepancy report type.	Yes
Detailed Description	Used to specify additional information about the discrepancy report type.	No
Status	Indicates the status of discrepancy report type. The valid values are: <ul style="list-style-type: none"> <li>• Active</li> <li>• Inactive</li> </ul>	Yes

**Tip:** Alternatively, you can create a copy of the **Discrepancy Report Type** zone to create a copy of the discrepancy report type.

5. Enter the required details in the **Main** section.
6. Define, edit, or remove characteristics from the discrepancy report type, if required.
7. Click **Save**.

The new discrepancy report type is defined.

### Related Topics

For more information on...	See...
How to define characteristics for a discrepancy report type	<a href="#">Defining Characteristics for a Discrepancy Report Type</a> on page 2266

## Viewing the Discrepancy Report Type Details

### Procedure

To view the details of a discrepancy report type:

1. Click the **Admin** link in the **Application** toolbar.  
A list appears.
2. From the **Admin** menu, select **D** and then click **Discrepancy Report Type**.  
A sub-menu appears.
3. Click the **Search** option from the **Discrepancy Report Type** sub-menu.  
The **Discrepancy Report Type** screen appears.
4. In the **Discrepancy Report Type List** zone, click the **Broadcast**  icon corresponding to the discrepancy report type whose details you want to view.  
The **Discrepancy Report Type** zone appears.
5. View the details of the discrepancy type in the **Discrepancy Report Type** zone.

### Related Topics

For more information on...	See...
<b>Discrepancy Report Type</b> screen	<a href="#">Discrepancy Report Type</a> on page 2262
<b>Discrepancy Report Type</b> zone	<a href="#">Discrepancy Report Type</a> on page 2263
<b>Discrepancy Report Type List</b> zone	<a href="#">Discrepancy Report Type List</a> on page 2262

## Discrepancy Report (Used for Searching)

The **Discrepancy Report** screen allows you to search for a discrepancy report using various search criteria. Through this screen, you can navigate to the following screen:

- [Discrepancy Report \(Used for Viewing\)](#) on page 2275
- [Search Discrepancy Report](#) on page 2270

### Search Discrepancy Report

The **Search Discrepancy Report** zone allows you to search for a discrepancy report using various search criteria. It contains the following two sections:

**Search Criteria** - The **Search Criteria** section contains the following fields:

Field Name	Field Description	Mandatory (Yes or No)
Search By	<p>Used to indicate whether you want to search for a discrepancy report using the discrepancy or account details. The valid values are:</p> <ul style="list-style-type: none"> <li>Discrepancy Details</li> <li>Account Details</li> </ul> <p><b>Note:</b> By default, the <b>Discrepancy Details</b> option is selected</p>	Yes
Discrepancy Report ID	<p>Used to search a particular discrepancy report..</p> <p><b>Note:</b> This field appears only when you select the <b>Discrepancy Details</b> option from the <b>Search By</b> list.</p>	No
Discrepancy Report Type	<p>Used to indicate the levels at which the discrepancy report is generated. It has following options:</p> <ul style="list-style-type: none"> <li>Account Level</li> <li>File Level</li> </ul> <p><b>Note:</b> This field appears only when <b>Discrepancy Details</b> is selected from the <b>Search By</b> list.</p>	No
Status	<p>Used to search a particular discrepancy reports with a particular status. The valid values are:</p> <ul style="list-style-type: none"> <li>Completed</li> <li>Draft</li> <li>Pending</li> </ul> <p><b>Note:</b> This field appears only when you select the <b>Discrepancy Details</b> option from the <b>Search By</b> list.</p>	No
File Name	<p>Used to specify the filename that is provided when a discrepancy report is created at file level.</p> <p><b>Note:</b> This field appears only when you select the <b>Discrepancy Details</b> option from the <b>Search By</b> list.</p>	No
Created From	<p>Used to search discrepancy reports which are created from a particular date onwards.</p> <p><b>Note:</b> This field appears only when you select the <b>Discrepancy Details</b> option from the <b>Search By</b> list.</p>	No
Created To	<p>Used to search for discrepancy report which is created till a particular date.</p> <p><b>Note:</b> This field appears only when you select the <b>Discrepancy Details</b> option from the <b>Search By</b> list.</p>	No

Field Name	Field Description	Mandatory (Yes or No)
Person Name	Used to search discrepancy reports through which a particular person's record is created or updated in the system.  <b>Note:</b> This field appears only when you select the <b>Account Details</b> option from the <b>Search By</b> list.	No
Account Identifier Type	Used to select the identifier type based on which you want to search discrepancy reports through which the account details are created or updated in the system. <ul style="list-style-type: none"> <li>Account Name</li> <li>Base Global Account ID</li> <li>Bill Group Identifier</li> <li>Demo Bank Account Number</li> <li>External Account Identifier</li> <li>Flexcube Account ID</li> <li>International Bank Account Number</li> </ul> <b>Note:</b> This field appears only when you select the <b>Account Details</b> option from the <b>Search By</b> list.	Yes (Conditional)  <b>Note:</b> If you specify the account identifier as a search criteria, you have to select the account identifier type.
Account Identifier	Used to specify the value for the account identifier type.  <b>Note:</b> This field appears only when <b>Account Details</b> is selected from the <b>Search By</b> list.	Yes (Conditional)  <b>Note:</b> If you specify the account identifier type as a search criteria, you have to specify the account identifier.
Account ID	Used to search discrepancy reports that are created by a particular user.  <b>Note:</b> This field appears only when you select the <b>Account Details</b> option from the <b>Search By</b> list.	No

**Note:** You must specify at least one search criterion while searching for a discrepancy report.

**Search Results** - On clicking the **Search** button, the search results appear based on the specified search criteria. The **Search Results** section contains the following columns:

Column Name	Column Description
Creation Date Time	Displays date and time when the discrepancy report was created.
Discrepancy Report Information	Displays information about the discrepancy report.  <b>Note:</b> It has a link. On clicking the link, the <b>Discrepancy Report</b> screen appears where you can view the details of the respective discrepancy report.



Column Name	Column Description
Status	Indicates the status of the discrepancy report. The valid values are: <ul style="list-style-type: none"> <li>• Pending</li> <li>• Draft</li> <li>• Completed</li> </ul>
Account ID	Displays the account ID of the person who created the discrepancy report.
File Name	Displays the filename given when discrepancy report is created at file level.

### Related Topics

For more information on...	See...
How to search for a discrepancy report	<a href="#">Searching for a Discrepancy Report</a> on page 2273
How to view the details of a discrepancy report	<a href="#">Viewing the Discrepancy Report Details</a> on page 2275

## Searching for a Discrepancy Report

### Prerequisites

To search for a discrepancy report, you should have:

- **C1-DiscrepancyReport** Business object defined for discrepancy report.
- Discrepancy Report Type defined for discrepancy report.
- Status defined for discrepancy report.

### Procedure

To search for a discrepancy report:

1. Click the **Menu** link in the **Application** toolbar.  
A list appears.
2. From the **Menu** menu, select **Financial** and then click **Discrepancy Report**.  
A sub-menu appears.
3. Click the **Search** option from the **Discrepancy Report** sub-menu.  
The **Discrepancy Report** screen appears.
4. Enter the search criteria in the **Search Discrepancy Report** zone.

**Note:** ORMB search engine supports wildcard search, where you can substitute the percentage (%) symbol as a stand in for any word or letter in a search criteria. You can use the ‘%’ wildcard character in all input fields except the date and ID fields. The ‘%’ wildcard character is suffixed automatically at the end of the partial search criteria. Therefore, you may or may not specify the wildcard character at the end of the partial search criteria. However, you have to prefix the wildcard character manually wherever required.

5. Click **Search**.

A list of discrepancy reports that meet the search criteria appear in the **Search Results** section.

### Related Topics

For more information on...	See...
<b>Discrepancy Report</b> screen	<a href="#">Discrepancy Report (Used for Searching)</a> on page 2270
<b>Discrepancy Report</b> zone	<a href="#">Search Discrepancy Report</a> on page 2270

## Creating a Discrepancy Report

### Prerequisites

To create a discrepancy report, you should have:

- Discrepancy Report Type defined in the application.
- Report Level defined in the application.

### Procedure

To create a discrepancy report:

1. Click the **Menu** link in the **Application** toolbar.  
A list appears.
2. From the **Main** menu, select **Financial** and then click **Discrepancy Report**.  
A sub-menu appears.
3. Click the **Add** option from the **Discrepancy Report** sub-menu.

The **Discrepancy Report** screen appears. It contains the following fields:

Field Name	Field Description	Mandatory (Yes or No)
Discrepancy Report Type	Used to indicate the discrepancy report type that you want to use to create the discrepancy report. The valid values are: <ul style="list-style-type: none"> <li>• Discrepancy Report Type</li> <li>• File Discrepancy Report Type</li> </ul>	Yes
Report Level	Used to specify the level at which the discrepancy report is created. The valid values are: <ul style="list-style-type: none"> <li>• At Account Level</li> <li>• At File Level</li> </ul>	Yes
File Name	Used to specify a name for the file when report level is selected as <b>At File Level</b> .	Yes (Conditional)  <b>Note:</b> This field is required when the report level is selected as <b>At File Level</b> while creating a discrepancy report.
Account ID	Used to specify an account ID when report level is selected as <b>At Account Level</b> .	Yes (Conditional)  <b>Note:</b> This field is required when the report level is selected as <b>At Account Level</b> while creating a discrepancy report.

**Tip:** Alternatively, you can access the **Select Discrepancy Report Type** screen by clicking the **Add** button in the **Page Title** area of the **Discrepancy Report** screen.

4. Enter the required details.
5. Click **Save**.

The **Discrepancy Report** is created.

#### Related Topics

For more information on...	See...
<b>Discrepancy Line Items</b> zone	<a href="#">Discrepancy Line Items</a> on page 2277
<b>Discrepancy Line Items Related Objects</b> zone	<a href="#">Discrepancy Line Item Related Objects</a> on page 2278
<b>Discrepancy Line Item Characteristics</b> zone	<a href="#">Discrepancy Line Items Characteristics Zone</a> on page 2279

## Viewing the Discrepancy Report Details

### Procedure

To view the details of a discrepancy report:

1. Search for the discrepancy report in the **Discrepancy Report** screen.
2. In the **Search Results** section, click the link in the **Discrepancy Report Information** column corresponding to the discrepancy report whose details you want to view.

The **Discrepancy Report** screen appears. It contains the following tabs:

- [Discrepancy Report - Main](#) on page 2276
- [Discrepancy Report - Log](#) on page 2279

3. Ensure that the **Main** tab is selected.
4. View the details of the discrepancy report in the **Discrepancy Report** zone.

### Related Topics

For more information on...	See...
How to search for a discrepancy report	<a href="#">Searching for a Discrepancy Report</a> on page 2273
<b>Discrepancy Report</b> screen	<a href="#">Discrepancy Report (Used for Viewing)</a> on page 2275
<b>Discrepancy Report</b> zone	<a href="#">Discrepancy Report - Main</a> on page 2276

## Discrepancy Report (Used for Viewing)

Once the discrepancy reports are created, the **Discrepancy Report** screen allows you to:

- View the details of discrepancy report.
- Delete a discrepancy report
- Edit a discrepancy line item
- Finalize a discrepancy report
- View the log of a discrepancy report

- Add a log entry for a discrepancy report
- View the discrepancy line item related objects

This screen consists of the following tabs:

- [Discrepancy Report - Main](#) on page 2276
- [Discrepancy Report - Log](#) on page 2279

For more information on...	See...
How to view the details of discrepancy report	<a href="#">Viewing the Discrepancy Report Details</a> on page 2275
How to delete a discrepancy report	<a href="#">Deleting a Discrepancy Report</a> on page 2281
How to edit a discrepancy line item	<a href="#">Editing a Discrepancy Line Item</a> on page 2279
How to add a log entry for a discrepancy report	<a href="#">Adding a Log Entry for a Discrepancy Report</a> on page 2282
How to view the log of a discrepancy report	<a href="#">Viewing the Log of a Discrepancy Report</a> on page 2282
<b>Discrepancy Line Item Related Objects</b> zone	<a href="#">Discrepancy Line Item Related Objects</a> on page 2278

## Discrepancy Report - Main

The **Discrepancy Report - Main** tab displays information about the discrepancy report. It contains the following zones:

- [Discrepancy Report](#) on page 2276
- [Discrepancy Line Items](#) on page 2277
- [Discrepancy Line Item Related Objects](#) on page 2278
- [Discrepancy Line Items Characteristics Zone](#) on page 2279

## Discrepancy Report

The **Discrepancy Report** zone displays the details of the discrepancy report. It contains the following sections:

- **Main** - Displays basic information about the discrepancy report. It contains the following fields:

Field Name	Field Description
Discrepancy Report Information	Displays information about the discrepancy report.
Discrepancy Report Type	Indicates the discrepancy report type using which the discrepancy report is created. <b>Note:</b> It has a link. On clicking the link, the <b>Discrepancy Report Type</b> screen appears where you can view the details of the discrepancy report type.
File Name	Displays the filename for which the discrepancy report is generated.
Account Information	Displays the details of the account for which discrepancy report is generated.
Status	Indicates the status of the discrepancy report. The valid values are: <ul style="list-style-type: none"> <li>• Pending</li> <li>• Draft</li> <li>• Completed</li> </ul>

- **Record Actions** - This section contains the following buttons:

Button Name	Button Description
Delete	Used to delete the discrepancy report.  <b>Note:</b> The <b>Delete</b> button appears only when the discrepancy report is in the <b>Pending</b> status.
Finalize	Used to finalize all the changes and process the discrepancy report.  <b>Note:</b> Finalize button appears only when the discrepancy report is in the <b>Pending</b> status.

- **Record Information** - This section contains the following fields:

Field Name	Field Description
Business Object	Indicates the business object using which the discrepancy report is created. In addition, a context menu appears corresponding to this field which helps in navigating to other screens in the application.  <b>Note:</b> It has a link. On clicking the link, the <b>Business Object</b> screen appears where you can view the details of the respective business object.
Status Date Time	Displays the date and time when the status of the discrepancy report was defined.
Creation Date Time	Displays the date and time when the discrepancy report was created.

### Discrepancy Line Items

The **Discrepancy Line Items** zone displays the details of the discrepancy report It contains the following columns:

Column Name	Column Description
Account ID	Indicates the account for which the discrepancy line item is created.  <b>Note:</b> This column appears only when you select the discrepancy report information where the filename is provided.
Policy Number	Indicates the policy number.
Plan Number	Indicates the plan number of the policy.
Member Identifier Type	Displays the member identifier type.
Member Identifier	Displays the value of the member identifier type.
Member Name	Displays the name of the member to whom the discrepancy report belongs.
Coverage Start Date	Displays the date from when the coverage starts.
Coverage End Date	Displays the date till when the coverage ends.
Billed Amount	Displays the bill segment amount.
Paid Amount	Displays the paid amount of the bill.
Discrepancy Amount	Displays the discrepancy amount.
Discrepancy Category	Displays the discrepancy category.

Column Name	Column Description
Consumer Status	Displays the status of the consumer for its existence in the application.
Comments	Displays the comments, added for the discrepancy line items.
Edit	<p>On clicking the <b>Edit</b> (✎) icon, the <b>Discrepancy Line Item</b> screen appears where you can edit the details of the discrepancy line item.</p> <p><b>Note:</b> The <b>Edit</b> icon appears only when the discrepancy report is in <b>Pending</b> or <b>Draft</b> status.</p>

**Note:**

On clicking the Broadcast (📡) icon corresponding to the discrepancy line item, the Discrepancy Line Item Related Objects and Discrepancy Line Item Characteristics zones appear.

You can filter the discrepancy line items using Discrepancy Category search criteria available in the Filter area. By default, the Filter area is hidden. You can view the Filter area by clicking the Filters (⌵) icon in the upper right corner of the Discrepancy Line Items zone.

Pagination is used to display limited number of records in the Search Results section. You can change the number of records displayed per page, if required. You can use the navigation links, such as Previous and Next to navigate between pages.

**Related Topics**

For more information on...	See...
How to view the details of discrepancy report	<a href="#">Viewing the Discrepancy Report Details</a> on page 2275
How to edit the details of discrepancy line items	<a href="#">Editing a Discrepancy Line Item</a> on page 2279

**Discrepancy Line Item Related Objects**

The **Discrepancy Line Item Related Objects** zone lists the related objects for the discrepancy line item. It contains the following columns:

Column Name	Column Description
Related Object Type	Displays <b>Financial Transaction</b> or <b>Member Pay Instruction</b> as the related object type.
Related Object Information	<p>Displays brief information about the related object type.</p> <p><b>Note:</b> It has a link. On clicking the link, the Pay Instruction screen appears with the details of the respective related object.</p>

By default, the Discrepancy Line Item Related Objects zone does not appear in the Discrepancy Report screen. It appears only when you click the Broadcast (📡) icon corresponding to the discrepancy line item in the Discrepancy Line Items zone.

Pagination is used to display limited number of records in the Search Results section. You can change the number of records displayed per page, if required. You can use the navigation links, such as Previous and Next to navigate between pages.

**Related Topics**

<b>For more information on...</b>	<b>See...</b>
<b>Discrepancy Line Items zone</b>	<a href="#">Discrepancy Line Items</a> on page 2277

### Discrepancy Line Items Characteristics Zone

**Note:** At present the **Discrepancy Line Item Characteristics** cannot be added. The Discrepancy Line Items Characteristics zone will be fully functional in the future release.

#### Related Topics

<b>For more information on...</b>	<b>See...</b>
How to view the details of discrepancy report	<a href="#">Viewing the Discrepancy Report Details</a> on page 2275
How to edit the details of discrepancy line items	<a href="#">Editing a Discrepancy Line Item</a> on page 2279

## Discrepancy Report - Log

The **Discrepancy Report - Log** tab contains the following zone:

- [Discrepancy Report Log](#) on page 2279

### Discrepancy Report Log

The **Discrepancy Report Log** zone lists the complete trail of actions performed on the Discrepancy Report. It contains the following columns:

Column Name	Column Description
Creation Date/Time	Displays the date and time when the action was performed on the discrepancy report.
Details	Displays the details about the action performed on the discrepancy report.
User	Indicates the user who has performed the action on the discrepancy report.
Log Type	Indicates the type of log.
Related Object	Indicates the object or entity which is generated when the action is performed on the discrepancy report.
Status Reason	Displays the status reason of the action performed on the discrepancy report object.

**Note:** You can manually add a log entry for the discrepancy report by clicking the **Add Log Entry** link in the upper right corner of the **Discrepancy Report Log** zone.

#### Related Topics

<b>For more information on...</b>	<b>See...</b>
How to view the log of the discrepancy report	<a href="#">Viewing the Log of a Discrepancy Report</a> on page 2282
How to add a log entry for a discrepancy report	<a href="#">Adding a Log Entry for a Reconciliation</a> on page 2256

## Editing a Discrepancy Line Item

### Prerequisites

To edit a discrepancy line item, you should have:

- Discrepancy Line Item status as Pending or Draft.

### **Procedure**

To edit a discrepancy line item:

1. Search for the discrepancy report in the **Discrepancy Report** screen.
2. In the **Search Results** section, click the link in the **Discrepancy Report Information** column corresponding to the discrepancy report, whose details you want to edit.

The **Discrepancy Report Information** screen appears.

3. In the **Discrepancy Line Items** zone, click the **Edit**  icon in the **Edit** corresponding to the discrepancy line item whose details you want to edit.

The **Discrepancy Line Item** screen appears.

**Note:** The **Edit** icon appears only when the discrepancy line item is in the **Pending** or **Draft** status.

The **Discrepancy Line Item** screen contains the following fields:

Field Name	Field Description
Discrepancy Report ID	Displays the discrepancy report ID.
Account ID	Indicates the account for which the discrepancy line item is created.
Policy Number	Indicates the policy number.
Plan Number	Indicates the plan number of the policy.
Member Identifier Type	Displays the member identifier type.
Member Identifier	Displays the value of the member identifier.
Member Name	Displays the name of the member to whom the discrepancy report belongs.
Coverage Start Date	Displays the start date of the coverage cycle.
Coverage End Date	Displays the end date of the coverage cycle.
Billed Amount	Displays the bill segment amount.
Paid Amount	Displays the paid amount of the bill amount.
Discrepancy Amount	Displays the amount that highlights the discrepancy value.
Discrepancy Category	Used to specify the discrepancy category. The valid values are: <ul style="list-style-type: none"> <li>• Billed Not Paid</li> <li>• Paid Not Billed</li> <li>• Rate Variance</li> </ul>
Comments	Used to specify additional details about the Discrepancy Line Item.

4. Modify the required details for the discrepancy line item.
5. Click **Save**.

The changes made to the discrepancy line item are saved.

### **Related Topics**



For more information on...	See...
How to view the details of discrepancy report	<a href="#">Viewing the Discrepancy Report Details</a> on page 2275
<b>Discrepancy Report</b> zone	<a href="#">Discrepancy Report</a> on page 2276

## Deleting a Discrepancy Report

### Procedure

To delete a discrepancy report:

1. Search for the discrepancy report in the **Discrepancy Report** screen.
2. In the **Search Results** section, click the link in the **Discrepancy Report Information** column corresponding to the discrepancy report that you want to delete.

The **Discrepancy Report** screen appears.

3. Click the **Delete** button in the **Discrepancy Report** zone.

A message appears confirming whether you want to delete the discrepancy report.

**Note:** The **Delete** button appears only when the discrepancy report is in the **Pending** or **Draft** status.

4. Click **OK**.

The discrepancy report is deleted.

### Related Topics

For more information on...	See...
How to search for a discrepancy report	<a href="#">Searching for a Discrepancy Report</a> on page 2273

## Finalizing a Discrepancy Report

### Prerequisites

To finalize a discrepancy report, you should have:

- Discrepancy Report status as Pending or Draft.

### Procedure

To finalize a discrepancy report:

1. Search for the discrepancy report in the **Discrepancy Report** screen.
2. In the **Search Results** section, click the link in the **Discrepancy Report Information** column corresponding to the discrepancy report that you want to finalize.

The **Discrepancy Report** screen appears.

3. Click the **Finalize** button in the **Discrepancy Report** zone.

The status of the discrepancy report is changed to **Completed**.

**Note:** The **Finalize** button appears only when the discrepancy report is in the **Pending** status.

### Related Topics

For more information on...	See...
How to search for a discrepancy report	<a href="#">Searching for a Discrepancy Report</a> on page 2273

## Adding a Log Entry for a Discrepancy Report

### Procedure

To add a log entry for a discrepancy report:

1. Search for the discrepancy report in the **Discrepancy Report** screen.
2. In the **Search Results** section, click the link in the **Discrepancy Report Information** column corresponding to the discrepancy report whose log you want to edit.

The **Discrepancy Report** screen is displayed. It consists of following tabs.

- [Discrepancy Report - Main](#) on page 2276
- [Discrepancy Report - Log](#) on page 2279

3. Click the **Log** tab.

The **Log** tab appears.

4. Click the **Add Log Entry** link in the upper right corner of the **Discrepancy Report Log** zone.

The **Add Discrepancy Report Log** window appears. It contains the following fields:

Field Name	Field Description	Mandatory (Yes or No)
Discrepancy Report Information	Displays information about the discrepancy report.	Not applicable
Log Details	Used to specify additional comments on the discrepancy report.	Yes

5. Enter the comments in the **Log Details** field.
6. Click **Save**.

The log entry is added in the **Discrepancy Report Log** zone.

### Related Topics

For more information on...	See...
How to search for a discrepancy report	<a href="#">Searching for a Discrepancy Report</a> on page 2273

## Viewing the Log of a Discrepancy Report

### Procedure

To view the log of a discrepancy report:

1. Search for the discrepancy report in the **Discrepancy Report** screen.
2. In the **Search Results** section, click the link in the **Discrepancy Report Information** column corresponding to the discrepancy report whose log you want to view.

The **Discrepancy Report** screen appears. It consists of the following tabs:

- [Discrepancy Report - Main](#) on page 2276
- [Discrepancy Report - Log](#) on page 2279

3. Click the **Log** tab.

The **Log** tab appears.

4. View the complete trail of actions performed on the discrepancy report in the **Discrepancy Report Log** zone.

**Related Topics**

<b>For more information on...</b>	<b>See...</b>
How to search for a discrepancy report	<a href="#">Searching for a Discrepancy Report</a> on page 2273



---

# Chapter

# 32

---

## Self-Funded Pricing

---

### Topics:

- [Prerequisites](#)
- [Approval Workflow for the Self-Funded Pricing Rules](#)
- [Line Item Extendable Lookup](#)
- [Extendable Lookup \(Line Item\)](#)
- [Claim Template Extendable Lookup](#)
- [Extendable Lookup \(Claim Template\)](#)
- [Rate Option Extendable Lookup](#)
- [Extendable Lookup \(Rate Option\)](#)
- [Pricing Group](#)
- [Pricing Rule Type](#)
- [Claim Pricing](#)
- [Specific Stop-Loss \(SSL\) Pricing](#)
- [Aggregate Stop-Loss \(ASL\) Pricing](#)
- [Retention Type Claim Based Pricing](#)
- [Retention Type Enrollment Based Pricing](#)
- [Flat Fee Pricing](#)
- [Ancillary Pricing](#)
- [Discount Pricing](#)
- [Level Funding Pricing](#)
- [Pricing Rule \(Used for Viewing\)](#)

Oracle Revenue Management and Billing introduces a new pricing model for the self-funded health care business. In this pricing model, you can define pricing rules using a pricing rule type. You can define the following pricing rule types in ORMB:

- Claim
- Aggregate Stop-Loss
- Specific Stop-Loss
- Retention Type Claim Based
- Retention Type Enrollment

## Prerequisites

To setup the self-funded pricing feature, you need to do the following:

- Define values for claim template extendable lookup
- Define values for rate option extendable lookup
- Define values for line item extendable lookup
- Setup the **C1-ASOBLNG** feature configuration
- Define price items for the pricing rules
- Define parameters for the pricing rules
- Associate parameters to the price items for the pricing rules

### Related Topics

For more information on...	See...
How to setup the <b>C1-ASOBLNG</b> feature configuration	<a href="#">Setting the C1-ASOBLNG Feature Configuration</a> on page 2889

## Approval Workflow for the Self-Funded Pricing Rules

Oracle Revenue Management and Billing enables you to configure the approval workflow process for the claim, specific stop-loss, aggregate stop-loss, retention type claim based, retention type enrollment based, flat fees, ancillary, discount, or level funded pricing rules. The following approval workflow groups are shipped with the product:

Approval Workflow Group	Description
C1PRCRLCLM	Claim Pricing Rule
C1PRCSSL	Specific Stop-Loss Pricing Rule
C1PRCASL	Aggregate Stop-Loss Pricing Rule
C1PRETCLM	Retention Type Claim Based Pricing Rule
C1PRRETENR	Retention Type Enrollment Based Pricing Rule
C1PRFLTTEE	Flat Fees Pricing Rule
C1PRCANC	Ancillary Pricing Rule
C1PRCDA	Discount Arrangement Pricing Rule
C1PRCLVLFN	Level Funded Pricing Rule

To enable the approval workflow process for the pricing rules, you need to do the following:

1. Create the required approval workflow chains, approval workflow criterion types, approval workflow group chain linkages, and approval workflow reasons.

**Note:** The **Field Level Approval** feature is not supported for the self-funded pricing rules. Therefore, you should not define field approval rule criteria while creating the approval workflow group chain linkage for the above listed approval workflow groups.

2. Define the approval workflow settings for the respective approval workflow group and set the **Active** field to **Yes**.

3. Ensure that the following value is set in the respective option type of the **C1-ASOBLNG** feature configuration:

Option Type	Value
Approval Workflow Group for Claim	C1PRCRLCLM
Approval Workflow Group for SSL	C1PRCSSL
Approval Workflow Group for ASL	C1PRCASL
Approval Workflow Group for Retention Type Claim Based	C1PRETCLM
Approval Workflow Group for Retention Type Enrollment Based	C1PRRETENR
Approval Workflow Group for Flat Fees	C1PRFLTFFEE
Approval Workflow Group for Ancillary	C1PRCANC
Approval Workflow Group for Discount Arrangement	C1PRCDA
Approval Workflow Group for Level Funded	C1PRCLVLFN

Once the approval workflow process is enabled for the pricing rules of a particular category (for example, Claim), the system creates an approval transaction whenever you define, edit, or delete a pricing rule of the respective category (i.e. whenever you define, edit, or delete a claim pricing rule). You can view the approval transactions which are created while defining, editing, and deleting the parent customer's and bill groups' pricing rules in the **Pricing Rule Approval Transactions** zone of the **Customer 360° Information** screen. On clicking the link in the **Approval Transaction ID** column corresponding to an approval transaction, the **Comparison: New versus Existing** screen appears. It allows the approver to review the pricing rule and accordingly approve, reject, or cancel the approval transaction.

**Tip:** Alternatively, you can review the approval transaction and take appropriate action from the **Approval Transaction** screen.

### **Related Topics**

For more information on...	See...
How to setup the <b>C1-ASOBLNG</b> feature configuration	<a href="#">Setting the C1-ASOBLNG Feature Configuration</a> on page 2889

## **Line Item Extendable Lookup**

Different charges, such as consumer-driven amount, traditional healthcare amount, network access fees, and so on are received as part of the claim transaction. These charges which contribute to the total claim amount are defined as the line items in the system. Each line item must be defined in the system using the **Line Item (C1-ExtLookPricingRuleLineItem)** extendable lookup. A line item encapsulates the following information:

- Service Quantity Identifier (SQI) which indicates the transaction field in which the charge amount is stored. It is also used while calculating the percentage based markup or markdown for the charge.
- Billable charge line type using which you want to create the calculation line for the charge.
- Whether the system should write off the charge when it is not eligible for billing.
- Billable charge line type using which you want to create the write off calculation line for the charge.
- Whether the charge should be considered while calculating the percentage based retention type claim based fee.
- The pricing rule type categories to which the charge is associated.

For example, you can create a line item for the following charges:

Charge	Line Item	Write Off, If Not Eligible for Billing	Pricing Rule Type Category
Consumer-Driven Amount	CDH	Yes	Claim
			Specific Stop-Loss
			Aggregate Stop-Loss
			Ancillary
Traditional Healthcare Amount	THC	Yes	Claim
			Specific Stop-Loss
			Aggregate Stop-Loss
Preventive Care Charges	PCC	No	Ancillary

The CDH and THC line items can be included in a claim template. They can also be considered while calculating specific and aggregate stop-loss. The CDH and PCC line items can be considered while defining pricing arrangements in an ancillary pricing rule type. In addition, any charge received for the CDH and THC line items in a claim transaction will be written off when these line items are not eligible for billing.

The **Extendable Lookup Query** screen allows you to search for an extendable lookup. It contains the following zone:

- [Extendable Lookup Search](#) on page 2288

## Extendable Lookup Search

The **Extendable Lookup Search** zone allows you to search for an extendable lookup. It contains the following two sections:

- **Search Criteria** – The **Search Criteria** section contains the following fields:

Field Name	Field Description	Mandatory (Yes or No)
Business Object	Used to search a particular extendable lookup business object.	No
Description	Used to search extendable lookups with a particular description.	No

**Note:** You must specify at least one search criterion while searching for an extendable lookup.

- **Search Results** – On clicking the **Search** button, the search results appear based on the specified search criteria. The **Search Results** section contains the following columns:

Column Name	Column Description
Business Object	Displays the extendable lookup business object.
Description	Displays the description of the extendable lookup business object.

**Note:** It has a link. On clicking the link, the **Extendable Lookup** screen appears where you can view the details of the respective extendable lookup.

### Related Topics



For more information on...	See...
How to search for the <b>Line Item</b> extendable lookup	<a href="#">Searching for the Line Item Extendable Lookup</a> on page 2289
How to view the values of the <b>Line Item</b> extendable lookup	<a href="#">Viewing the Values of the Line Item Extendable Lookup</a> on page 2289

## Searching for the Line Item Extendable Lookup

### Procedure

To search for the **Line Item** extendable lookup:

1. Click the **Admin** link in the **Application** toolbar.  
A list appears.
2. From the **Admin** menu, select **E** and then click **Extendable Lookup**.  
The **Extendable Lookup Query** screen appears.
3. In the **Extendable Lookup Search** zone, enter **C1-ExtLookPricingRuleLineItem** in the **Business Object** field.

**Note:** ORMB search engine supports wildcard search, where you can substitute the percentage (%) symbol as a stand in for any word or letter in a search criteria. You can use the ‘%’ wildcard character in all input fields except the date and ID fields. The ‘%’ wildcard character is suffixed automatically at the end of the partial search criteria. Therefore, you may or may not specify the wildcard character at the end of the partial search criteria. However, you have to prefix the wildcard character manually wherever required.

4. Click **Search**.

The **Line Item** extendable lookup business object appears in the **Search Results** section.

### Related Topics

For more information on...	See...
<b>Extendable Lookup Query</b> screen	<a href="#">Line Item Extendable Lookup</a> on page 2287
<b>Extendable Lookup Search</b> zone	<a href="#">Extendable Lookup Search</a> on page 2288

## Viewing the Values of the Line Item Extendable Lookup

### Procedure

To view the values of the **Line Item** extendable lookup:

1. Search for the **Line Item** extendable lookup in the **Extendable Lookup Query** screen.
2. In the **Search Results** section, click the link in the **Description** column corresponding to the extendable lookup business object whose details you want to view.  
The **Extendable Lookup** screen appears.
3. View the values of the **Line Item** extendable lookup in the **Extendable Lookup Value List** zone.

### Related Topics

For more information on...	See...
How to search for the <b>Line Item</b> extendable lookup	<a href="#">Searching for the Line Item Extendable Lookup</a> on page 2289

For more information on...	See...
<b>Extendable Lookup</b> screen	<a href="#">Extendable Lookup (Line Item)</a> on page 2290
<b>Extendable Lookup Value List</b> zone	<a href="#">Extendable Lookup Value List</a> on page 2290



## Extendable Lookup (Line Item)

The **Extendable Lookup** screen allows you to view the values of the **Line Item (C1-ExtLookPricingRuleLineItem)** extendable lookup. It also allows you to define, edit, copy, and delete a line item. It contains the following zones:

- [Extendable Lookup Value List](#) on page 2290
- [Extendable Lookup Value](#) on page 2291

## Extendable Lookup Value List

The **Extendable Lookup Value List** zone lists the values which are already defined for the **Line Item** extendable lookup. It contains the following columns:

Column Name	Column Description
Value	Displays the line item.
Description	Displays the description of the line item.
Owner	Indicates who has created the line item. The valid values are: <ul style="list-style-type: none"> <li>• Framework</li> <li>• Base</li> <li>• Customer Modification</li> </ul>
Edit	On clicking the <b>Edit</b> (  ) icon, the <b>Line Item</b> screen appears where you can edit the details of the line item.
Duplicate	On clicking the <b>Duplicate</b> (  ) icon, the <b>Line Item</b> screen appears where you can define a new line item using an existing line item.
Delete	On clicking the <b>Delete</b> (  ) icon, you can delete the line item. <div style="border: 1px solid black; padding: 5px; margin-top: 10px;"> <p><b>Note:</b> You can delete a line item only when it is not yet used in the claim template or while defining the self-funded pricing.</p> </div>
Detailed Description	Displays additional information about the line item.

**Note:** Pagination is used to display limited number of records in this zone. You can use the navigation buttons, such as **Previous** and **Next** to navigate between pages.

On clicking the **Broadcast** () icon corresponding to a line item, the **Extendable Lookup Value** zone appears with the details of the respective line item.

You can filter the list using various search criteria (such as, **Value** and **Description**) available in the **Filter** area. By default, the **Filter** area is hidden. You can view the **Filter** area by clicking the **Filters** () icon in the upper right corner of this zone.

### Related Topics

For more information on...	See...
How to edit a line item	<a href="#">Editing a Line Item</a> on page 2296
How to copy a line item	<a href="#">Copying a Line Item</a> on page 2298
How to delete a line item	<a href="#">Deleting a Line Item</a> on page 2300
How to view the details of a line item	<a href="#">Viewing the Line Item Details</a> on page 2300

## Extendable Lookup Value

The **Extendable Lookup Value** zone displays the details of the line item. It contains the following sections:

- **Main** – Displays basic information about the line item. It contains the following fields:

Field Name	Field Description
Line Item	Indicates the charge for which the line item is created.
Description	Displays the description of the line item.
Override Description	Displays the overridden description of the line item.
Detailed Description	Displays additional information about the line item.
Status	Indicates the status of the line item. The valid values are: <ul style="list-style-type: none"> <li>• Active</li> <li>• Inactive</li> </ul>
Service Quantity Identifier	Indicates the service quantity identifier associated with the line item.
Billable Charge Line Type	Indicates the billable charge line type using which the calculation line is created for the charge (i.e. line item).
Write Off Billable Charge Line Type	Indicates the billable charge line type using which the write off calculation line is created for the charge (i.e. line item).
Write Off, if Not Eligible for Billing	Indicates whether the system should write off the charge (i.e. line item) when it is not eligible for billing. The valid values are: <ul style="list-style-type: none"> <li>• Yes</li> <li>• No</li> </ul>
Retention Claim Based Percentage Calculation	Indicates whether the charge (i.e. line item) should be considered while calculating the percentage based retention type claim based fee. The valid values are: <ul style="list-style-type: none"> <li>• Yes</li> <li>• No</li> </ul>

- **Line Item Usage** – Lists the pricing rule type categories to which the line item is associated. It contains the following field in a grid:

Field Name	Field Description
Pricing Rule Type Category	<p>Indicates the pricing rule type category which is associated with the charge (i.e. line item). The valid values are:</p> <ul style="list-style-type: none"> <li>Aggregate Stop-Loss</li> <li>Ancillary</li> <li>Claim</li> <li>Retention Type Claim Based</li> <li>Specific Stop-Loss</li> </ul>

- **Record Actions** – This section contains the following buttons:

Button Name	Button Description
Edit	Used to edit the details of the line item.
Delete	<p>Used to delete the line item.</p> <div style="border: 1px solid black; padding: 5px; margin-top: 5px;"> <p><b>Note:</b> You can delete a line item only when it is not yet used in the claim template or while defining the self-funded pricing.</p> </div>
Duplicate	Used to create a new line item using an existing line item.

- **Record Information** – This section contains the following fields:

Field Name	Field Description
Business Object	<p>Indicates the extendable lookup business object using which the line item is created. In addition, a context menu appears corresponding to this field which helps in navigating to other screens in the application.</p> <div style="border: 1px solid black; padding: 5px; margin-top: 5px;"> <p><b>Note:</b> It has a link. On clicking the link, the <b>Business Object</b> screen appears where you can view the details of the respective business object.</p> </div>
Owner	<p>Indicates who has created the line item. The valid values are:</p> <ul style="list-style-type: none"> <li>Framework</li> <li>Base</li> <li>Customer Modification</li> </ul>

By default, the **Extendable Lookup Value** zone does not appear in the **Extendable Lookup** screen. It appears only when you click the **Broadcast**  icon corresponding to the line item in the **Extendable Lookup Value List** zone.

### **Related Topics**

For more information on...	See...
How to edit a line item	<a href="#">Editing a Line Item</a> on page 2296
How to copy a line item	<a href="#">Copying a Line Item</a> on page 2298
How to delete a line item	<a href="#">Deleting a Line Item</a> on page 2300
How to view the details of a line item	<a href="#">Viewing the Line Item Details</a> on page 2300

## Defining a Line Item

### Prerequisites

To define a line item, you should have:

- Service quantity identifiers and billable charge line types defined in the application

### Procedure

To define a line item:

1. Search for the **Line Item** extendable lookup in the **Extendable Lookup Query** screen.
2. In the **Search Results** section, click the link in the **Description** column corresponding to the extendable lookup business object whose details you want to view.

The **Extendable Lookup** screen appears.

3. Click the **Add** button in the **Page Title** area of the **Extendable Lookup** screen.

The **Line Item** screen appears. It contains the following sections:

- **Main** – Used to specify basic details about the line item.
- **Line Item Usage** – Used to associate the line item with one or more pricing rule type categories.

The **Main** section contains the following fields:

Field Name	Field Description	Mandatory (Yes or No)
Line Item	Used to specify the charge (for example, consumer-driven amount, traditional healthcare amount, and so on) for which the line item is created.	Yes
Description	Used to specify the description for the line item.	Yes
Override Description	Used when you want to override the description of the line item.	No
Detailed Description	Used to specify additional information about the line item.	No
Status	Used to indicate the status of the line item. The valid values are: <ul style="list-style-type: none"> <li>• Active</li> <li>• Inactive</li> </ul> <div style="border: 1px solid black; padding: 2px; margin-top: 5px;"><b>Note:</b> By default, the value is set to <b>Active</b>.</div>	Yes
Service Quantity Identifier	Used to indicate the service quantity identifier (SQI) for the line item. The SQI indicates the transaction field in which the charge amount is stored. It is also used while calculating the percentage based markup or markdown for the line item.	Yes

Field Name	Field Description	Mandatory (Yes or No)
Billable Charge Line Type	Used to indicate the billable charge line type using which you want to create the calculation line for the charge (i.e. line item).  <b>Note:</b> The <b>Search</b> (🔍) icon appears corresponding to this field. On clicking the <b>Search</b> icon, the <b>Billable Charge Line Type Search</b> window appears.	Yes
Write Off Billable Charge Line Type	Used to indicate the billable charge line type using which you want to create the write off calculation line for the charge (i.e. line item).  <b>Note:</b> The <b>Search</b> (🔍) icon appears corresponding to this field. On clicking the <b>Search</b> icon, the <b>Billable Charge Line Type Search</b> window appears.	Yes (Conditional)  <b>Note:</b> This field is required when the <b>Write Off, if Not Eligible for Billing</b> field is set to <b>Yes</b> .
Write Off, if Not Eligible for Billing	Used to indicate whether the system should write off the charge (i.e. line item) when it is not eligible for billing. The valid values are:  <ul style="list-style-type: none"> <li>• Yes</li> <li>• No</li> </ul> <b>Note:</b> By default, the value is set to <b>No</b> .	No
Retention Claim Based Percentage Calculation	Used to indicate whether the charge (i.e. line item) should be considered while calculating the percentage based retention type claim based fee. The valid values are:  <ul style="list-style-type: none"> <li>• Yes</li> <li>• No</li> </ul> <b>Note:</b> By default, the value is set to <b>No</b> .	No

4. Enter the required details in the **Main** section.
5. Associate the line item with one or more pricing rule type categories.
6. Click **Save**.

The line item is added in the **C1-ExtLookPricingRuleLineItem** extendable lookup.

#### **Related Topics**

For more information on...	See...
How to search for the <b>Line Item</b> extendable lookup	<a href="#">Searching for the Line Item Extendable Lookup</a> on page 2289
<b>Extendable Lookup</b> screen	<a href="#">Extendable Lookup (Line Item)</a> on page 2290
How to associate a line item with a pricing rule type category	<a href="#">Associating a Line Item with a Pricing Rule Type Category</a> on page 2294

## **Associating a Line Item with a Pricing Rule Type Category**

**Procedure**

To associate a line item with a pricing rule type category:

1. Ensure that the **Line Item Usage** section is expanded when you are defining, editing, or copying a line item.

The **Line Item Usage** section contains the following field in a grid:

Field Name	Field Description	Mandatory (Yes or No)												
Pricing Rule Type Category	<p>Used to indicate the pricing rule type category which you want to associate with the charge (i.e. line item). The valid values are:</p> <ul style="list-style-type: none"> <li>• Aggregate Stop-Loss</li> <li>• Ancillary</li> <li>• Claim</li> <li>• Retention Type Claim Based</li> <li>• Specific Stop-Loss</li> </ul> <p>The following table describes the significance of each category that can be associated with the line item:</p> <table border="1"> <thead> <tr> <th>Pricing Rule Type Category</th> <th>Significance</th> </tr> </thead> <tbody> <tr> <td>Claim</td> <td>Whether the line item can be included in a claim template and thereby while defining a claim pricing rule for a parent customer and bill group.</td> </tr> <tr> <td>Specific Stop-Loss</td> <td>Whether the line item can be considered while calculating specific stop-loss.</td> </tr> <tr> <td>Aggregate Stop-Loss</td> <td>Whether the line item can be considered while calculating aggregate stop-loss.</td> </tr> <tr> <td>Retention Type Claim Based</td> <td>Whether the line item can be used while calculating the percentage based retention type claim based fee.</td> </tr> <tr> <td>Ancillary</td> <td>Whether the line item can be considered while defining pricing arrangements in an ancillary pricing rule type.</td> </tr> </tbody> </table> <p><b>Note:</b> At present, the line items are not used in the pricing rule types where the pricing rule type category is set to <b>Retention Type Enrollment Based</b> and <b>Flat Fees</b>.</p>	Pricing Rule Type Category	Significance	Claim	Whether the line item can be included in a claim template and thereby while defining a claim pricing rule for a parent customer and bill group.	Specific Stop-Loss	Whether the line item can be considered while calculating specific stop-loss.	Aggregate Stop-Loss	Whether the line item can be considered while calculating aggregate stop-loss.	Retention Type Claim Based	Whether the line item can be used while calculating the percentage based retention type claim based fee.	Ancillary	Whether the line item can be considered while defining pricing arrangements in an ancillary pricing rule type.	<p>Yes (Conditional)</p> <p><b>Note:</b> This field is required when you are associating the line item with a pricing rule type category.</p>
Pricing Rule Type Category	Significance													
Claim	Whether the line item can be included in a claim template and thereby while defining a claim pricing rule for a parent customer and bill group.													
Specific Stop-Loss	Whether the line item can be considered while calculating specific stop-loss.													
Aggregate Stop-Loss	Whether the line item can be considered while calculating aggregate stop-loss.													
Retention Type Claim Based	Whether the line item can be used while calculating the percentage based retention type claim based fee.													
Ancillary	Whether the line item can be considered while defining pricing arrangements in an ancillary pricing rule type.													

2. Enter the required details in the **Line Item Usage** section.

- If you want to associate the line item with more than one pricing rule type category, click the **Add (+)** icon and then repeat step 3.

**Note:** However, if you want to remove a pricing rule type category from the line item, click the **Delete (🗑)** icon corresponding to the pricing rule type category.

- Click **Save**.

The line item is associated with the pricing rule type category.

### **Related Topics**

<b>For more information on...</b>	<b>See...</b>
How to define a line item	<a href="#">Defining a Line Item</a> on page 2293
How to edit a line item	<a href="#">Editing a Line Item</a> on page 2296
How to copy a line item	<a href="#">Copying a Line Item</a> on page 2298

## **Editing a Line Item**

### **Prerequisites**

To edit a line item, you should have:

- Service quantity identifiers and billable charge line types defined in the application

### **Procedure**

To edit a line item:

- Search for the **Line Item** extendable lookup in the **Extendable Lookup Query** screen.
- In the **Search Results** section, click the link in the **Description** column corresponding to the extendable lookup business object whose details you want to view.

The **Extendable Lookup** screen appears.

- In the **Extendable Lookup Value List** zone, click the **Edit (✎)** icon in the **Edit** column corresponding to the line item whose details you want to edit.

The **Line Item** screen appears. It contains the following sections:

- Main** – Used to specify basic details about the line item.
- Line Item Usage** – Used to associate the line item with one or more pricing rule type categories.

The **Main** section contains the following fields:

<b>Field Name</b>	<b>Field Description</b>	<b>Mandatory (Yes or No)</b>
Line Item	Indicates the charge for which the line item is created.	Not applicable
Description	Used to specify the description for the line item.	Yes
Override Description	Used when you want to override the description of the line item.	No
Detailed Description	Used to specify additional information about the line item.	No



Field Name	Field Description	Mandatory (Yes or No)
Status	Used to indicate the status of the line item. The valid values are: <ul style="list-style-type: none"> <li>Active</li> <li>Inactive</li> </ul>	Yes
Owner	Indicates who has created the rate option. The valid values are: <ul style="list-style-type: none"> <li>Framework</li> <li>Base</li> <li>Customer Modification</li> </ul>	Not applicable
Service Quantity Identifier	Used to indicate the service quantity identifier (SQI) for the line item. The SQI indicates the transaction field in which the charge amount is stored. It is also used while calculating the percentage based markup or markdown for the line item.	Yes
Billable Charge Line Type	Used to indicate the billable charge line type using which you want to create the calculation line for the charge (i.e. line item). <div style="border: 1px solid black; padding: 5px; margin-top: 10px;"> <p><b>Note:</b> The <b>Search</b> (🔍) icon appears corresponding to this field. On clicking the <b>Search</b> icon, the <b>Billable Charge Line Type Search</b> window appears.</p> </div>	Yes
Write Off Billable Charge Line Type	Used to indicate the billable charge line type using which you want to create the write off calculation line for the charge (i.e. line item). <div style="border: 1px solid black; padding: 5px; margin-top: 10px;"> <p><b>Note:</b> The <b>Search</b> (🔍) icon appears corresponding to this field. On clicking the <b>Search</b> icon, the <b>Billable Charge Line Type Search</b> window appears.</p> </div>	Yes (Conditional) <div style="border: 1px solid black; padding: 5px; margin-top: 10px;"> <p><b>Note:</b> This field is required when the <b>Write Off, if Not Eligible for Billing</b> field is set to <b>Yes</b>.</p> </div>
Write Off, if Not Eligible for Billing	Used to indicate whether the system should write off the charge (i.e. line item) when it is not eligible for billing. The valid values are: <ul style="list-style-type: none"> <li>Yes</li> <li>No</li> </ul>	No
Retention Claim Based Percentage Calculation	Used to indicate whether the charge (i.e. line item) should be considered while calculating the percentage based retention type claim based fee. The valid values are: <ul style="list-style-type: none"> <li>Yes</li> <li>No</li> </ul>	No

**Tip:** Alternatively, you can edit the details of a line item by clicking the **Edit** button in the **Extendable Lookup Value** zone.

4. Modify the required details in the **Main** section.

5. Associate or remove a pricing rule type category from the line item, if required.
6. Click **Save**.

The changes made to the line item are saved.

### Related Topics

For more information on...	See...
How to search for the <b>Line Item</b> extendable lookup	<a href="#">Searching for the Line Item Extendable Lookup</a> on page 2289
<b>Extendable Lookup</b> screen	<a href="#">Extendable Lookup (Line Item)</a> on page 2290
<b>Extendable Lookup Value List</b> zone	<a href="#">Extendable Lookup Value List</a> on page 2290
<b>Extendable Lookup Value</b> zone	<a href="#">Extendable Lookup Value</a> on page 2291
How to associate a line item with a pricing rule type category	<a href="#">Associating a Line Item with a Pricing Rule Type Category</a> on page 2294

## Copying a Line Item

Instead of creating a line item from scratch, you can create a new line item using an existing line item. This is possible through copying a line item. On copying a line item, the details including the pricing rule type categories to which the line item is associated are copied to the new line item. You can then edit the details, if required.

### Prerequisites

To copy a line item, you should have:

- Line item (whose copy you want to create) defined in the application
- Service quantity identifiers and billable charge line types defined in the application

### Procedure

To copy a line item:

1. Search for the **Line Item** extendable lookup in the **Extendable Lookup Query** screen.
2. In the **Search Results** section, click the link in the **Description** column corresponding to the extendable lookup business object whose details you want to view.

The **Extendable Lookup** screen appears.

3. In the **Extendable Lookup Value List** zone, click the **Duplicate** () icon in the **Duplicate** column corresponding to the line item whose copy you want to create.

The **Line Item** screen appears. It contains the following sections:

- **Main** – Used to specify basic details about the line item.
- **Line Item Usage** – Used to associate the line item with one or more pricing rule type categories.

The **Main** section contains the following fields:

Field Name	Field Description	Mandatory (Yes or No)
Line Item	Used to specify the charge (for example, consumer-driven amount, traditional healthcare amount, and so on) for which the line item is created.	Yes
Description	Used to specify the description for the line item.	Yes

Field Name	Field Description	Mandatory (Yes or No)
Override Description	Used when you want to override the description of the line item.	No
Detailed Description	Used to specify additional information about the line item.	No
Status	Used to indicate the status of the line item. The valid values are: <ul style="list-style-type: none"> <li>Active</li> <li>Inactive</li> </ul>	Yes
Service Quantity Identifier	Used to indicate the service quantity identifier (SQI) for the line item. The SQI indicates the transaction field in which the charge amount is stored. It is also used while calculating the percentage based markup or markdown for the line item.	Yes
Billable Charge Line Type	Used to indicate the billable charge line type using which you want to create the calculation line for the charge (i.e. line item). <div style="border: 1px solid black; padding: 5px; margin-top: 10px;"> <p><b>Note:</b> The <b>Search</b> (🔍) icon appears corresponding to this field. On clicking the <b>Search</b> icon, the <b>Billable Charge Line Type Search</b> window appears.</p> </div>	Yes
Write Off Billable Charge Line Type	Used to indicate the billable charge line type using which you want to create the write off calculation line for the charge (i.e. line item). <div style="border: 1px solid black; padding: 5px; margin-top: 10px;"> <p><b>Note:</b> The <b>Search</b> (🔍) icon appears corresponding to this field. On clicking the <b>Search</b> icon, the <b>Billable Charge Line Type Search</b> window appears.</p> </div>	Yes (Conditional) <div style="border: 1px solid black; padding: 5px; margin-top: 10px;"> <p><b>Note:</b> This field is required when the <b>Write Off, if Not Eligible for Billing</b> field is set to <b>Yes</b>.</p> </div>
Write Off, if Not Eligible for Billing	Used to indicate whether the system should write off the charge (i.e. line item) when it is not eligible for billing. The valid values are: <ul style="list-style-type: none"> <li>Yes</li> <li>No</li> </ul>	No
Retention Claim Based Percentage Calculation	Used to indicate whether the charge (i.e. line item) should be considered while calculating the percentage based retention type claim based fee. The valid values are: <ul style="list-style-type: none"> <li>Yes</li> <li>No</li> </ul>	No

**Tip:** Alternatively, you can copy a line item by clicking the **Duplicate** button in the **Extendable Lookup Value** zone.

- Enter the required details in the **Main** section.
- Associate or remove a pricing rule type category from the line item, if required.

## 6. Click **Save**.

The new line item is added in the **C1-ExtLookPricingRuleLineItem** extendable lookup.

### Related Topics

For more information on...	See...
How to search for the <b>Line Item</b> extendable lookup	<a href="#">Searching for the Line Item Extendable Lookup</a> on page 2289
<b>Extendable Lookup</b> screen	<a href="#">Extendable Lookup (Line Item)</a> on page 2290
<b>Extendable Lookup Value List</b> zone	<a href="#">Extendable Lookup Value List</a> on page 2290
<b>Extendable Lookup Value</b> zone	<a href="#">Extendable Lookup Value</a> on page 2291
How to associate a line item with a pricing rule type category	<a href="#">Associating a Line Item with a Pricing Rule Type Category</a> on page 2294

## Deleting a Line Item

### Procedure

To delete a line item:

1. Search for the **Line Item** extendable lookup in the **Extendable Lookup Query** screen.
2. In the **Search Results** section, click the link in the **Description** column corresponding to the extendable lookup business object whose details you want to view.

The **Extendable Lookup** screen appears.

3. In the **Extendable Lookup Value List** zone, click the **Delete** (🗑️) icon in the **Delete** column corresponding to the line item that you want to delete.

A message appears confirming whether you want to delete the line item.

**Note:** You can delete a line item only when it is not yet used in the claim template or while defining the Administrative Services Only (ASO) pricing.

**Tip:** Alternatively, you can delete a line item by clicking the **Delete** button in the **Extendable Lookup Value** zone.

4. Click **OK**.

The line item is deleted from the **C1-ExtLookPricingRuleLineItem** extendable lookup.

### Related Topics

For more information on...	See...
How to search for the <b>Line Item</b> extendable lookup	<a href="#">Searching for the Line Item Extendable Lookup</a> on page 2289
<b>Extendable Lookup</b> screen	<a href="#">Extendable Lookup (Line Item)</a> on page 2290
<b>Extendable Lookup Value List</b> zone	<a href="#">Extendable Lookup Value List</a> on page 2290
<b>Extendable Lookup Value</b> zone	<a href="#">Extendable Lookup Value</a> on page 2291

## Viewing the Line Item Details

### Procedure

To view the details of a line item:

1. Search for the **Line Item** extendable lookup in the **Extendable Lookup Query** screen.
2. In the **Search Results** section, click the link in the **Description** column corresponding to the extendable lookup business object whose details you want to view.

The **Extendable Lookup** screen appears.

3. In the **Extendable Lookup Value List** zone, click the **Broadcast**  icon corresponding to the line item whose details you want to view.

The **Extendable Lookup Value** zone appears.

4. View the details of the line item in the **Extendable Lookup Value** zone.

### **Related Topics**

<b>For more information on...</b>	<b>See...</b>
How to search for the <b>Line Item</b> extendable lookup	<a href="#">Searching for the Line Item Extendable Lookup</a> on page 2289
<b>Extendable Lookup</b> screen	<a href="#">Extendable Lookup (Line Item)</a> on page 2290
<b>Extendable Lookup Value List</b> zone	<a href="#">Extendable Lookup Value List</a> on page 2290
<b>Extendable Lookup Value</b> zone	<a href="#">Extendable Lookup Value</a> on page 2291

## **Claim Template Extendable Lookup**

The ASO service provider may bill different charges for a claim transaction to different employers. The system enables you to create different claim templates for different employers. A claim template contains a set of charges (i.e. line items) which can be billed to a parent customer or bill group. You can define multiple claim templates in the system. Each claim template must be defined in the system using the **Claim Template (C1-ExtLookClaimTemplate)** extendable lookup. A claim template encapsulates the following information:

- Whether the claim template can be used while defining a claim pricing rule for a policy which is in the **In Force/Active, Post Runout, or Runout** status.
- Line items which can be billed to a parent customer or bill group.
- Whether you want to calculate the markup or markdown on the line items which are included in the claim template.
- Whether you want to specify a flat markup or markdown amount for the line items or the markup or markdown percentage for the line items which are eligible for percentage based markup or markdown
- Whether a line item is eligible for billing or not.
- Whether you want to define rule based billing eligibility for a line item.
- Whether you want to define billing eligibility for a line item while defining a claim pricing rule.
- Rule type which indicates the rules that should be executed to determine whether the line item is eligible for billing.
- Whether the line item is eligible for percentage based markup or markdown when the markup or markdown type is set to **Percentage**.

Once a claim template is defined in the extendable lookup, you can associate the claim template with a claim pricing rule type. You can associate multiple claim templates with a claim pricing rule type. Then, while defining a claim pricing rule for a parent customer, you can use any one of the claim template associated with the respective claim pricing rule type. The system then inherits the line items and the default markup and markdown values in the claim pricing rule from the claim template.

However, while defining a claim pricing rule for a policy of a bill group, you can only use the claim templates which are defined for the respective policy status and associated with the respective claim pricing rule type.

For example, you can create the claim templates with the following line items:

Claim Template	Policy Status	Line Item	Billing Eligibility	Pricing Strategy	Markup or Markdown Type	Markup or Markdown Amount	Markdown or Markdown Percentage
CT1	In Force/ Active	CDH	Yes	Markup	Flat Amount	\$2	-
		THC	Yes				
		PCC	No				
CT2	Runout	CDH	Yes	Markdown	Percentage	-	2.00
		THC	Yes				
CT3	Post Runout	PCC	Yes	None	-	-	-
		NAF	No				

The **Extendable Lookup Query** screen allows you to search for an extendable lookup. It contains the following zone:

- [Extendable Lookup Search](#) on page 2302

## Extendable Lookup Search

The **Extendable Lookup Search** zone allows you to search for an extendable lookup. It contains the following two sections:

- **Search Criteria** – The **Search Criteria** section contains the following fields:

Field Name	Field Description	Mandatory (Yes or No)
Business Object	Used to search a particular extendable lookup business object.	No
Description	Used to search extendable lookups with a particular description.	No

**Note:** You must specify at least one search criterion while searching for an extendable lookup.

- **Search Results** – On clicking the **Search** button, the search results appear based on the specified search criteria. The **Search Results** section contains the following columns:

Column Name	Column Description
Business Object	Displays the extendable lookup business object.
Description	Displays the description of the extendable lookup business object.

**Note:** It has a link. On clicking the link, the **Extendable Lookup** screen appears where you can view the details of the respective extendable lookup.

### Related Topics

For more information on...	See...
How to search for the <b>Claim Template</b> extendable lookup	<a href="#">Searching for the Claim Template Extendable Lookup</a> on page 2303
How to view the values of the <b>Claim Template</b> extendable lookup	<a href="#">Viewing the Values of the Claim Template Extendable Lookup</a> on page 2303

## Searching for the Claim Template Extendable Lookup

### Procedure

To search for the **Claim Template** extendable lookup:

1. Click the **Admin** link in the **Application** toolbar.  
A list appears.
2. From the **Admin** menu, select **E** and then click **Extendable Lookup**.  
The **Extendable Lookup Query** screen appears.
3. In the **Extendable Lookup Search** zone, enter **C1-ExtLookClaimTemplate** in the **Business Object** field.

**Note:** ORMB search engine supports wildcard search, where you can substitute the percentage (%) symbol as a stand in for any word or letter in a search criteria. You can use the ‘%’ wildcard character in all input fields except the date and ID fields. The ‘%’ wildcard character is suffixed automatically at the end of the partial search criteria. Therefore, you may or may not specify the wildcard character at the end of the partial search criteria. However, you have to prefix the wildcard character manually wherever required.

4. Click **Search**.

The **Claim Template** extendable lookup business object appears in the **Search Results** section.

### Related Topics

For more information on...	See...
<b>Extendable Lookup Query</b> screen	<a href="#">Claim Template Extendable Lookup</a> on page 2301
<b>Extendable Lookup Search</b> zone	<a href="#">Extendable Lookup Search</a> on page 2302

## Viewing the Values of the Claim Template Extendable Lookup

### Procedure

To view the values of the **Claim Template** extendable lookup:

1. Search for the **Claim Template** extendable lookup in the **Extendable Lookup Query** screen.
2. In the **Search Results** section, click the link in the **Description** column corresponding to the extendable lookup business object whose details you want to view.  
The **Extendable Lookup** screen appears.
3. View the values of the **Claim Template** extendable lookup in the **Extendable Lookup Value List** zone.

### Related Topics

For more information on...	See...
How to search for the <b>Claim Template</b> extendable lookup	<a href="#">Searching for the Claim Template Extendable Lookup</a> on page 2303
<b>Extendable Lookup</b> screen	<a href="#">Extendable Lookup (Claim Template)</a> on page 2304

<b>For more information on...</b>	<b>See...</b>
<b>Extendable Lookup Value List zone</b>	<a href="#">Extendable Lookup Value List</a> on page 2304



## Extendable Lookup (Claim Template)

The **Extendable Lookup** screen allows you to view the values of the **Claim Template (C1-ExtLookClaimTemplate)** extendable lookup. It also allows you to define, edit, copy, and delete a claim template. It contains the following zones:

- [Extendable Lookup Value List](#) on page 2304
- [Extendable Lookup Value](#) on page 2305

### Extendable Lookup Value List

The **Extendable Lookup Value List** zone lists the values which are already defined for the **Claim Template** extendable lookup. It contains the following columns:

Column Name	Column Description
Value	Displays the claim template.
Description	Displays the description of the claim template.
Owner	Indicates who has created the claim template. The valid values are: <ul style="list-style-type: none"> <li>• Framework</li> <li>• Base</li> <li>• Customer Modification</li> </ul>
Edit	On clicking the <b>Edit</b> (  ) icon, the <b>Claim Template</b> screen appears where you can edit the details of the claim template.
Duplicate	On clicking the <b>Duplicate</b> (  ) icon, the <b>Claim Template</b> screen appears where you can define a new claim template using an existing claim template.
Delete	On clicking the <b>Delete</b> (  ) icon, you can delete the claim template. <div style="border: 1px solid black; padding: 5px; margin-top: 5px;"> <p><b>Note:</b> You can delete a claim template only when it is not yet used in a claim pricing rule type.</p> </div>
Detailed Description	Displays additional information about the claim template.

**Note:** Pagination is used to display limited number of records in this zone. You can use the navigation buttons, such as **Previous** and **Next** to navigate between pages.

On clicking the **Broadcast** () icon corresponding to a claim template, the **Extendable Lookup Value** zone appears with the details of the respective claim template.

You can filter the list using various search criteria (such as, **Value** and **Description**) available in the **Filter** area. By default, the **Filter** area is hidden. You can view the **Filter** area by clicking the **Filters** () icon in the upper right corner of this zone.

#### **Related Topics**



For more information on...	See...
How to edit a claim template	<a href="#">Editing a Claim Template</a> on page 2313
How to copy a claim template	<a href="#">Copying a Claim Template</a> on page 2315
How to delete a claim template	<a href="#">Deleting a Claim Template</a> on page 2316
How to view the details of a claim template	<a href="#">Viewing the Claim Template Details</a> on page 2317

## Extendable Lookup Value

The **Extendable Lookup Value** zone displays the details of the claim template. It contains the following sections:

- **Main** – Displays basic information about the claim template. It contains the following fields:

Field Name	Field Description
Claim Template	Displays the claim template.
Description	Displays the description of the claim template.
Override Description	Displays the overridden description of the claim template.
Detailed Description	Displays additional information about the claim template.
Status	Indicates the status of the claim template. The valid values are: <ul style="list-style-type: none"> <li>• Active</li> <li>• Inactive</li> </ul>

- **Claim Template Usage** – Indicates when the claim template can be used while defining a claim pricing rule for a policy of a bill group. It contains the following field:

Field Name	Field Description
Policy Status	Indicates whether the claim template should be used while defining a claim pricing rule for a policy which is in the <b>In Force/Active</b> , <b>Post Runout</b> , or <b>Runout</b> status. The valid values are: <ul style="list-style-type: none"> <li>• In Force/Active</li> <li>• Post Runout</li> <li>• Runout</li> </ul>

- **Default Markup or Markdown Values** – Indicates the default markup or markdown values defined for the line items in the claim template. It contains the following fields:

Field Name	Field Description
Pricing Strategy	Indicates whether you want to markup or markdown the line items. The valid values are: <ul style="list-style-type: none"> <li>• None</li> <li>• Markup</li> <li>• Markdown</li> </ul>

Field Name	Field Description
Markup or Markdown Type	<p>Indicates whether you want a flat or percentage based markup or markdown on the line items. The valid values are:</p> <ul style="list-style-type: none"> <li>• Flat Amount</li> <li>• Percentage</li> </ul> <p><b>Note:</b> This field appears only when the <b>Markup</b> or <b>Markdown</b> option is selected from the <b>Pricing Strategy</b> list.</p>
Markup or Markdown Amount	<p>Displays the default flat markup or markdown amount for the line items.</p> <p><b>Note:</b> This field appears only when the <b>Flat Amount</b> option is selected from the <b>Markup or Markdown Type</b> list.</p>
Markup or Markdown Percentage	<p>Displays the default percentage of markup or markdown for all line items.</p> <p><b>Note:</b> This field appears only when the <b>Percentage</b> option is selected from the <b>Markup or Markdown Type</b> list.</p>

- **Line Items** – Lists the line items which are added in the claim template. It contains the following columns:

Column Name	Column Description
Sequence	Indicates the order in which the calculation line should be generated for the line item.
Line Item	Indicate the line item which is added in the claim template.
Billing Eligibility	<p>Indicates whether the line item is eligible for billing. The valid values are:</p> <ul style="list-style-type: none"> <li>• Eligible</li> <li>• Not Eligible</li> <li>• Rule Based</li> <li>• Used Defined (Default No)</li> <li>• User Defined (Default Yes)</li> </ul>
Rule Type	<p>Indicates that rules of the specified rule type should be executed to determine whether the line item is eligible for billing.</p> <p><b>Note:</b> The data appears in this column only when the <b>Rule Based</b> option is selected from the <b>Billing Eligibility</b> list.</p>
Markup or Markdown Percentage Eligibility	<p>Indicates whether the line item is eligible for percentage based markup or markdown when the <b>Markup or Markdown Type</b> field is set to <b>Percentage</b>. The valid values are:</p> <ul style="list-style-type: none"> <li>• Eligible</li> <li>• Not Eligible</li> </ul>

- **Record Actions** – This section contains the following buttons:

Button Name	Button Description
Edit	Used to edit the details of the claim template.

Button Name	Button Description
Delete	Used to delete the claim template.  <b>Note:</b> You can delete a claim template only when it is not yet used in a claim pricing rule type.
Duplicate	Used to create a new claim template using an existing claim template.

- **Record Information** – This section contains the following fields:

Field Name	Field Description
Business Object	Indicates the extendable lookup business object using which the claim template is created. In addition, a context menu appears corresponding to this field which helps in navigating to other screens in the application.  <b>Note:</b> It has a link. On clicking the link, the <b>Business Object</b> screen appears where you can view the details of the respective business object.
Owner	Indicates who has created the claim template. The valid values are: <ul style="list-style-type: none"> <li>• Framework</li> <li>• Base</li> <li>• Customer Modification</li> </ul>

By default, the **Extendable Lookup Value** zone does not appear in the **Extendable Lookup** screen. It appears only when you click the **Broadcast**  icon corresponding to the claim template in the **Extendable Lookup Value List** zone.

### Related Topics

For more information on...	See...
How to edit a claim template	<a href="#">Editing a Claim Template</a> on page 2313
How to copy a claim template	<a href="#">Copying a Claim Template</a> on page 2315
How to delete a claim template	<a href="#">Deleting a Claim Template</a> on page 2316
How to view the details of a claim template	<a href="#">Viewing the Claim Template Details</a> on page 2317

## Defining a Claim Template

### Procedure

To define a claim template:

1. Search for the **Claim Template** extendable lookup in the **Extendable Lookup Query** screen.
2. In the **Search Results** section, click the link in the **Description** column corresponding to the extendable lookup business object whose details you want to view.

The **Extendable Lookup** screen appears.

3. Click the **Add** button in the **Page Title** area of the **Extendable Lookup** screen.

The **Claim Template** screen appears. It contains the following sections:

- **Main** – Used to specify basic details about the claim template. It contains the following fields:

Field Name	Field Description	Mandatory (Yes or No)
Claim Template	Used to specify the claim template.	Yes
Description	Used to specify the description for the claim template.	Yes
Override Description	Used when you want to override the description of the claim template.	No
Detailed Description	Used to specify additional information about the claim template.	No
Status	Used to indicate the status of the claim template. The valid values are: <ul style="list-style-type: none"> <li>Active</li> <li>Inactive</li> </ul> <div style="border: 1px solid black; padding: 2px; margin-top: 5px;"><b>Note:</b> By default, the value is set to <b>Active</b>.</div>	Yes

- **Claim Template Usage** – Used to indicate when the claim template can be used while defining a claim pricing rule for a policy of a bill group. It contains the following field:

Field Name	Field Description	Mandatory (Yes or No)
Policy Status	Used to indicate whether you want to use the claim template while defining a claim pricing rule for a policy which is in the <b>In Force/Active</b> , <b>Post Runout</b> , or <b>Runout</b> status. The valid values are: <ul style="list-style-type: none"> <li>In Force/Active</li> <li>Post Runout</li> <li>Runout</li> </ul>	Yes

- **Default Markup or Markdown Values** – Used to indicate the default markup or markdown values for the line items which are added in the claim template.
  - **Line Items** – Used to add the line items in the claim template.
4. Enter the required details in the **Main** section.
  5. Select the **In Force/Active**, **Post Runout**, or **Runout** option from the **Policy Status** list depending on whether you want to use the claim template while defining a claim pricing rule for a policy in
  6. Add the required line items in the claim template.
  7. Define the default markup or markdown values for the line items, if required.
  8. Click **Save**.

The claim template is added in the **C1-ExtLookClaimTemplate** extendable lookup.

#### Related Topics

For more information on...	See...
How to search for the <b>Claim Template</b> extendable lookup	<a href="#">Searching for the Claim Template Extendable Lookup</a> on page 2303
<b>Extendable Lookup</b> screen	<a href="#">Extendable Lookup (Claim Template)</a> on page 2304

For more information on...	See...
How to add the line items in a claim template	<a href="#">Adding a Line Item in a Claim Template</a> on page 2309
How to define the default markup or markdown values for the line items	<a href="#">Defining the Default Markup or Markdown Values for the Line Items</a> on page 2311

## Adding a Line Item in a Claim Template

### Prerequisites

To add a line item in a claim template, you should have:

- The line item defined in the **C1-ExtLookPricingRuleLineItem** extendable lookup.
- Rule types defined in the application (where the rule type usage is set to **ASO Billing Line Item Eligibility**) when you want to define rule based billing eligibility for a line item.

### Procedure

To add a line item in a claim template:

1. Ensure that the **Line Items** section is expanded when you are defining, editing, or copying a claim template.

The **Line Items** section contains the following fields in a grid:

Field Name	Field Description	Mandatory (Yes or No)
Sequence	Used to indicate the order in which the calculation line should be generated for the line item.	Yes (Conditional) <b>Note:</b> This field is required while adding a line item in the claim template.
Line Item	Used to indicate the line item that you want to include in the claim template. <b>Note:</b> The list includes only those line items which are associated to the <b>Claim</b> pricing rule type category.	Yes (Conditional) <b>Note:</b> This field is required while adding a line item in the claim template.

Field Name	Field Description	Mandatory (Yes or No)
Billing Eligibility	<p>Used to indicate whether the line item is eligible for billing. If line item is not eligible for billing, the system does not create the calculation line for the line item. The valid values are:</p> <ul style="list-style-type: none"> <li>• <b>Eligible</b> - Used when the line item is eligible for billing.</li> <li>• <b>Not Eligible</b> - Used when the line item is not eligible for billing.</li> <li>• <b>Rule Based</b> - Used when you want to determine whether the line item is eligible for billing using certain business rules while executing the <b>Update Status (C1-TXNEX)</b> batch.</li> <li>• <b>Used Defined (Default No)</b> - Used when you want to define billing eligibility for the line item while defining a claim pricing rule using the claim template. If you select this option, by default, the <b>User Defined Billing Option</b> option is not selected for the line item in the claim pricing rule.</li> <li>• <b>User Defined (Default Yes)</b> - Used when you want to define billing eligibility for the line item while defining a claim pricing rule using the claim template. If you select this option, by default, the <b>User Defined Billing Option</b> option is selected for the line item in the claim pricing rule.</li> </ul>	<p>Yes (Conditional)</p> <div style="border: 1px solid black; padding: 5px; margin-top: 10px;"> <p><b>Note:</b> This field is required while adding a line item in the claim template.</p> </div>

Field Name	Field Description	Mandatory (Yes or No)
Rule Type	Used to indicate that rules of the specified rule type should be executed to determine whether the line item is eligible for billing.  <b>Note:</b> The list includes only those rule types where the rule type usage is set to <b>ASO Billing Line Item Eligibility</b> . The values appear in this list only when you select the <b>Rule Based</b> option from the <b>Billing Eligibility</b> list.	Yes (Conditional)  <b>Note:</b> This field is required when you select the <b>Rule Based</b> option from the <b>Billing Eligibility</b> list.
Markup or Markdown Percentage Eligibility	Used to indicate whether the line item is eligible for percentage based markup or markdown when the <b>Markup or Markdown Type</b> field is set to <b>Percentage</b> . The valid values are:  <ul style="list-style-type: none"> <li>• Eligible</li> <li>• Not Eligible</li> </ul>	Yes (Conditional)  <b>Note:</b> This field is required while adding a line item in the claim template.

- Enter the required details in the **Line Items** section.
- If you want to add more than one line item in the claim template, click the **Add** (+) icon and then repeat step 2.

**Note:** However, if you want to remove a line item from the claim template, click the **Delete** (🗑️) icon corresponding to the line item.

- Click **Save**.

The line item is added in the claim template.

### **Related Topics**

For more information on...	See...
How to define a claim template	<a href="#">Defining a Claim Template</a> on page 2307
How to edit a claim template	<a href="#">Editing a Claim Template</a> on page 2313
How to copy a claim template	<a href="#">Copying a Claim Template</a> on page 2315

## **Defining the Default Markup or Markdown Values for the Line Items**

### **Procedure**

To define the default markup or markdown values for the line items:

- Ensure that the **Default Markup or Markdown Values** section is expanded when you are defining, editing, or copying a claim template.

The **Default Markup or Markdown Values** section contains the following fields:

Field Name	Field Description	Mandatory (Yes or No)
Pricing Strategy	<p>Used to indicate whether you want to markup or markdown the line items. The valid values are:</p> <ul style="list-style-type: none"> <li>• None</li> <li>• Markup</li> <li>• Markdown</li> </ul> <p><b>Note:</b> By default, the value is set to <b>Markup</b>.</p>	<p>Yes (Conditional)</p> <p><b>Note:</b> This field is required when you are defining the default markup or markdown values for the line items.</p>
Markup or Markdown Type	<p>Used to indicate whether you want a flat or percentage based markup or markdown. The valid values are:</p> <ul style="list-style-type: none"> <li>• Flat Amount</li> <li>• Percentage</li> </ul> <p><b>Note:</b> This field appears only when you select the <b>Markup</b> or <b>Markdown</b> option from the <b>Pricing Strategy</b> list.</p>	<p>Yes (Conditional)</p> <p><b>Note:</b> This field is required when you select the <b>Markup</b> or <b>Markdown</b> option from the <b>Pricing Strategy</b> list.</p>
Markup or Markdown Amount	<p>Used to specify the default flat markup or markdown amount for the line items. The specified flat amount appears, by default, when you define a claim pricing rule using the claim template. You can change the flat markup or markdown amount for the line items while defining a claim pricing rule using the claim template. In this case, the system will create only one markup or markdown calculation line for all line items.</p> <p><b>Note:</b> This field appears only when you select the <b>Flat Amount</b> option from the <b>Markup or Markdown Type</b> list.</p>	<p>Yes (Conditional)</p> <p><b>Note:</b> This field is required when you select the <b>Flat Amount</b> option from the <b>Markup or Markdown Type</b> list.</p>



Field Name	Field Description	Mandatory (Yes or No)
Markup or Markdown Percentage	Used to specify the default percentage of markup or markdown for all line items. The specified percentage appears, by default, for all line items when you define a claim pricing rule using the claim template. You can change the percentage of markup or markdown for each line item while defining a claim pricing rule using the claim template. In this case, the system will create a markup or markdown calculation line for each line item which is eligible for percentage based markup or markdown.  <b>Note:</b> This field appears only when you select the <b>Percentage</b> option from the <b>Markup or Markdown Type</b> list.	Yes (Conditional)  <b>Note:</b> This field is required when you select the <b>Percentage</b> option from the <b>Markup or Markdown Type</b> list.

- Enter the required details in the **Default Markup or Markdown Values** section.
- Click **Save**.

The default markup or markdown values are defined in the claim template.

#### Related Topics

For more information on...	See...
How to define a claim template	<a href="#">Defining a Claim Template</a> on page 2307
How to edit a claim template	<a href="#">Editing a Claim Template</a> on page 2313
How to copy a claim template	<a href="#">Copying a Claim Template</a> on page 2315

## Editing a Claim Template

### Procedure

To edit a claim template:

- Search for the **Claim Template** extendable lookup in the **Extendable Lookup Query** screen.
- In the **Search Results** section, click the link in the **Description** column corresponding to the extendable lookup business object whose details you want to view.  
  
The **Extendable Lookup** screen appears.
- In the **Extendable Lookup Value List** zone, click the **Edit** (✎) icon in the **Edit** column corresponding to the claim template whose details you want to edit.

The **Claim Template** screen appears. It contains the following sections:

- Main** – Used to specify basic details about the claim template. It contains the following fields:

Field Name	Field Description	Mandatory (Yes or No)
Claim Template	Displays the claim template.	Not applicable
Description	Used to specify the description for the claim template.	Yes

Field Name	Field Description	Mandatory (Yes or No)
Override Description	Used when you want to override the description of the claim template.	No
Detailed Description	Used to specify additional information about the claim template.	No
Status	Used to indicate the status of the claim template. The valid values are: <ul style="list-style-type: none"> <li>Active</li> <li>Inactive</li> </ul>	Yes
Owner	Indicates who has created the claim template. The valid values are: <ul style="list-style-type: none"> <li>Framework</li> <li>Base</li> <li>Customer Modification</li> </ul>	Not applicable

- **Claim Template Usage** – Used to indicate when the claim template can be used while defining a claim pricing rule for a policy of a bill group. It contains the following field:

Field Name	Field Description	Mandatory (Yes or No)
Policy Status	Used to indicate whether you want to use the claim template while defining a claim pricing rule for a policy which is in the <b>In Force/Active</b> , <b>Post Runout</b> , or <b>Runout</b> status. The valid values are: <ul style="list-style-type: none"> <li>In Force/Active</li> <li>Post Runout</li> <li>Runout</li> </ul>	Yes

- **Default Markup or Markdown Values** – Used to indicate the default markup or markdown value for the line items which are added in the claim template.
- **Line Items** – Used to add the line items in the claim template.

**Tip:** Alternatively, you can edit the details of a claim template by clicking the **Edit** button in the **Extendable Lookup Value** zone.

4. Modify the required details in the **Main** section.
5. Modify the policy status in the **Claim Template Usage** section, if required.
6. Add, edit, or remove line items from the claim template, if required.
7. Edit the default markup or markdown values for the line items, if required.
8. Click **Save**.

The changes made to the claim template are saved.

### **Related Topics**

For more information on...	See...
How to search for the <b>Claim Template</b> extendable lookup	<a href="#">Searching for the Claim Template Extendable Lookup</a> on page 2303

For more information on...	See...
<b>Extendable Lookup</b> screen	<a href="#">Extendable Lookup (Claim Template)</a> on page 2304
<b>Extendable Lookup Value List</b> zone	<a href="#">Extendable Lookup Value List</a> on page 2304
<b>Extendable Lookup Value</b> zone	<a href="#">Extendable Lookup Value</a> on page 2305
How to add the line items in a claim template	<a href="#">Adding a Line Item in a Claim Template</a> on page 2309
How to define the default markup or markdown values for the line items	<a href="#">Defining the Default Markup or Markdown Values for the Line Items</a> on page 2311

## Copying a Claim Template

Instead of creating a claim template from scratch, you can create a new claim template using an existing claim template. This is possible through copying a claim template. On copying a claim template, the details including the line items and default markup or markdown values are copied to the new claim template. You can then edit the details, if required.

### Prerequisites

To copy a claim template, you should have:

- Claim template (whose copy you want to create) defined in the application

### Procedure

To copy a claim template:

1. Search for the **Claim Template** extendable lookup in the **Extendable Lookup Query** screen.
2. In the **Search Results** section, click the link in the **Description** column corresponding to the extendable lookup business object whose details you want to view.

The **Extendable Lookup** screen appears.

3. In the **Extendable Lookup Value List** zone, click the **Duplicate** () icon in the **Duplicate** column corresponding to the claim template whose copy you want to create.

The **Claim Template** screen appears. It contains the following sections:

- **Main** – Used to specify basic details about the claim template. It contains the following fields:

Field Name	Field Description	Mandatory (Yes or No)
Claim Template	Used to specify the claim template.	Yes
Description	Used to specify the description for the claim template.	Yes
Override Description	Used when you want to override the description of the claim template.	No
Detailed Description	Used to specify additional information about the claim template.	No
Status	Used to indicate the status of the claim template. The valid values are: <ul style="list-style-type: none"> <li>• Active</li> <li>• Inactive</li> </ul>	Yes

- **Claim Template Usage** – Used to indicate when the claim template can be used while defining a claim pricing rule for a policy of a bill group. It contains the following field:

Field Name	Field Description	Mandatory (Yes or No)
Policy Status	Used to indicate whether you want to use the claim template while defining a claim pricing rule for a policy which is in the <b>In Force/Active, Post Runout</b> , or <b>Runout</b> status. The valid values are: <ul style="list-style-type: none"> <li>In Force/Active</li> <li>Post Runout</li> <li>Runout</li> </ul>	Yes

- **Default Markup or Markdown Values** – Used to indicate the default markup or markdown value for the line items which are added in the claim template.
- **Line Items** – Used to add the line items in the claim template.

**Tip:** Alternatively, you can copy a claim template by clicking the **Duplicate** button in the **Extendable Lookup Value** zone.

4. Enter the required details in the **Main** section.
5. Select the **In Force/Active, Post Runout**, or **Runout** option from the **Policy Status** list depending on whether you want to use the claim template while defining a claim pricing rule for a policy in a particular status.
6. Add, edit, or remove line items from the claim template, if required.
7. Edit the default markup or markdown values for the line items, if required.
8. Click **Save**.

The new claim template is added in the **C1-ExtLookClaimTemplate** extendable lookup.

#### Related Topics

For more information on...	See...
How to search for the <b>Claim Template</b> extendable lookup	<a href="#">Searching for the Claim Template Extendable Lookup</a> on page 2303
<b>Extendable Lookup</b> screen	<a href="#">Extendable Lookup (Claim Template)</a> on page 2304
<b>Extendable Lookup Value List</b> zone	<a href="#">Extendable Lookup Value List</a> on page 2304
<b>Extendable Lookup Value</b> zone	<a href="#">Extendable Lookup Value</a> on page 2305
How to add the line items in a claim template	<a href="#">Adding a Line Item in a Claim Template</a> on page 2309
How to define the default markup or markdown values for the line items	<a href="#">Defining the Default Markup or Markdown Values for the Line Items</a> on page 2311

## Deleting a Claim Template

### Procedure

To delete a claim template:

1. Search for the **Claim Template** extendable lookup in the **Extendable Lookup Query** screen.
2. In the **Search Results** section, click the link in the **Description** column corresponding to the extendable lookup business object whose details you want to view.

The **Extendable Lookup** screen appears.

- In the **Extendable Lookup Value List** zone, click the **Delete** () icon in the **Delete** column corresponding to the claim template that you want to delete.

A message appears confirming whether you want to delete the claim template.

**Note:** You can delete a claim template only when it is not yet used in a claim pricing rule type.

**Tip:** Alternatively, you can delete a claim template by clicking the **Delete** button in the **Extendable Lookup Value** zone.

- Click **OK**.

The claim template is deleted from the **C1-ExtLookClaimTemplate** extendable lookup.

### Related Topics

For more information on...	See...
How to search for the <b>Claim Template</b> extendable lookup	<a href="#">Searching for the Claim Template Extendable Lookup</a> on page 2303
<b>Extendable Lookup</b> screen	<a href="#">Extendable Lookup (Claim Template)</a> on page 2304
<b>Extendable Lookup Value List</b> zone	<a href="#">Extendable Lookup Value List</a> on page 2304
<b>Extendable Lookup Value</b> zone	<a href="#">Extendable Lookup Value</a> on page 2305

## Viewing the Claim Template Details

### Procedure

To view the details of a claim template:

- Search for the **Claim Template** extendable lookup in the **Extendable Lookup Query** screen.
- In the **Search Results** section, click the link in the **Description** column corresponding to the extendable lookup business object whose details you want to view.

The **Extendable Lookup** screen appears.

- In the **Extendable Lookup Value List** zone, click the **Broadcast** () icon corresponding to the claim template whose details you want to view.

The **Extendable Lookup Value** zone appears.

- View the details of the claim template in the **Extendable Lookup Value** zone.

### Related Topics

For more information on...	See...
How to search for the <b>Claim Template</b> extendable lookup	<a href="#">Searching for the Claim Template Extendable Lookup</a> on page 2303
<b>Extendable Lookup</b> screen	<a href="#">Extendable Lookup (Claim Template)</a> on page 2304
<b>Extendable Lookup Value List</b> zone	<a href="#">Extendable Lookup Value List</a> on page 2304
<b>Extendable Lookup Value</b> zone	<a href="#">Extendable Lookup Value</a> on page 2305

## Rate Option Extendable Lookup

The basic pricing details (such as rate schedule, pricing currency) and the transaction aggregation details may vary from one bill group or parent customer to another and from one price item to another. The basic pricing and transaction aggregation details are defined in the rate option. Each rate option must be defined in the system using the **Rate Option (C1-ExtLookRetTypeRateOpt)** extendable lookup. A rate option encapsulates the following information:

- The rate schedule that you want to use while defining the price item pricing.
- Currency in which you want to define the price item pricing.
- Whether zero pricing should be displayed in the bill.
- Whether the transactions mapped to the price item should be ignored for billing.
- Whether the transactions mapped to the price item should be aggregated for billing.
- The aggregation schedule using which the transactions should be aggregated for billing.
- How and when you want to rate the transaction legs which are mapped to the price item.
- Whether you want the price item pricing to be applied to all customers or only to the new customers.

Once the rate options are defined in the extendable lookup, you can associate one or more rate options with a price item while adding the price item in a claim, specific stop-loss, aggregate stop-loss, retention type claim based, retention type enrollment based, or ancillary pricing rule type. You can then use the rate option while defining pricing rule for the respective price item using the respective pricing rule type. The rate option specified in a pricing rule is used while creating the price item pricing or price assignment for the pricing rule. For example,

Claim Pricing Rule Type	Price Item	Rate Option	Claim Pricing Rule	Price Item Pricing
CPRT1	P1	R1	CPR1 (Price Item: P1, Rate Option: R1)	PA1 is created for P1 using the details specified in R1.
		R2	-	-
		R3	CPR2 (Price Item: P1, Rate Option: R3)	PA2 is created for P1 using the details specified in R3.
	P2	R1	-	-
		R4	CPR3 (Price Item: P2, Rate Option: R4)	PA3 is created for P2 using the details specified in R4.
CPRT2	P1	R1	CPR4 (Price Item: P1, Rate Option: R1)	PA4 is created for P1 using the details specified in R1.

The **Extendable Lookup Query** screen allows you to search for an extendable lookup. It contains the following zone:

- [Extendable Lookup Search](#) on page 2318

### Extendable Lookup Search

The **Extendable Lookup Search** zone allows you to search for an extendable lookup. It contains the following two sections:

- **Search Criteria** – The **Search Criteria** section contains the following fields:

Field Name	Field Description	Mandatory (Yes or No)
Business Object	Used to search a particular extendable lookup business object.	No
Description	Used to search extendable lookups with a particular description.	No

**Note:** You must specify at least one search criterion while searching for an extendable lookup.

- **Search Results** – On clicking the **Search** button, the search results appear based on the specified search criteria. The **Search Results** section contains the following columns:

Column Name	Column Description
Business Object	Displays the extendable lookup business object.
Description	Displays the description of the extendable lookup business object.

**Note:** It has a link. On clicking the link, the **Extendable Lookup** screen appears where you can view the details of the respective extendable lookup.

### Related Topics

For more information on...	See...
How to search for the <b>Rate Option</b> extendable lookup	<a href="#">Searching for the Rate Option Extendable Lookup</a> on page 2319
How to view the values of the <b>Rate Option</b> extendable lookup	<a href="#">Viewing the Values of the Rate Option Extendable Lookup</a> on page 2320

## Searching for the Rate Option Extendable Lookup

### Procedure

To search for the **Rate Option** extendable lookup:

1. Click the **Admin** link in the **Application** toolbar.  
A list appears.
2. From the **Admin** menu, select **E** and then click **Extendable Lookup**.  
The **Extendable Lookup Query** screen appears.
3. In the **Extendable Lookup Search** zone, enter **C1-ExtLookRetTypeRateOpt** in the **Business Object** field.

**Note:** ORMB search engine supports wildcard search, where you can substitute the percentage (%) symbol as a stand in for any word or letter in a search criteria. You can use the ‘%’ wildcard character in all input fields except the date and ID fields. The ‘%’ wildcard character is suffixed automatically at the end of the partial search criteria. Therefore, you may or may not specify the wildcard character at the end of the partial search criteria. However, you have to prefix the wildcard character manually wherever required.

4. Click **Search**.

The **Rate Option** extendable lookup business object appears in the **Search Results** section.

### Related Topics

For more information on...	See...
Extendable Lookup Query screen	<a href="#">Rate Option Extendable Lookup</a> on page 2318
Extendable Lookup Search zone	<a href="#">Extendable Lookup Search</a> on page 2318

## Viewing the Values of the Rate Option Extendable Lookup

### Procedure

To view the values of the **Rate Option** extendable lookup:

1. Search for the **Rate Option** extendable lookup in the **Extendable Lookup Query** screen.
2. In the **Search Results** section, click the link in the **Description** column corresponding to the extendable lookup business object whose details you want to view.

The **Extendable Lookup** screen appears.

3. View the values of the **Rate Option** extendable lookup in the **Extendable Lookup Value List** zone.

### Related Topics

For more information on...	See...
How to search for the <b>Rate Option</b> extendable lookup	<a href="#">Searching for the Rate Option Extendable Lookup</a> on page 2319
<b>Extendable Lookup</b> screen	<a href="#">Extendable Lookup (Rate Option)</a> on page 2320
<b>Extendable Lookup Value List</b> zone	<a href="#">Extendable Lookup Value List</a> on page 2320

## Extendable Lookup (Rate Option)

The **Extendable Lookup** screen allows you to view the values of the **Rate Option (C1-ExtLookRetTypeRateOpt)** extendable lookup. It also allows you to define, edit, copy, and delete a rate option. It contains the following zones:



- [Extendable Lookup Value List](#) on page 2320
- [Extendable Lookup Value](#) on page 2321

### Extendable Lookup Value List

The **Extendable Lookup Value List** zone lists the values which are already defined for the **Rate Option** extendable lookup. It contains the following columns:

Column Name	Column Description
Value	Displays the rate option.
Description	Displays the description of the rate option.
Owner	Indicates who has created the rate option. The valid values are: <ul style="list-style-type: none"> <li>• Framework</li> <li>• Base</li> <li>• Customer Modification</li> </ul>
Edit	On clicking the <b>Edit</b>  icon, the <b>Rate Option</b> screen appears where you can edit the details of the rate option.



Column Name	Column Description
Duplicate	On clicking the <b>Duplicate</b> (  ) icon, the <b>Rate Option</b> screen appears where you can define a new rate option using an existing rate option.
Delete	On clicking the <b>Delete</b> (  ) icon, you can delete the rate option. <b>Note:</b> You can delete a rate option only when it is not yet used in a pricing rule type.
Detailed Description	Displays additional information about the rate option.

**Note:** Pagination is used to display limited number of records in this zone. You can use the navigation buttons, such as **Previous** and **Next** to navigate between pages.

On clicking the **Broadcast** () icon corresponding to a rate option, the **Extendable Lookup Value** zone appears with the details of the respective rate option.

You can filter the list using various search criteria (such as, **Value** and **Description**) available in the **Filter** area. By default, the **Filter** area is hidden. You can view the **Filter** area by clicking the **Filters** () icon in the upper right corner of this zone.

### Related Topics

For more information on...	See...
How to edit a rate option	<a href="#">Editing a Rate Option</a> on page 2326
How to copy a rate option	<a href="#">Copying a Rate Option</a> on page 2329
How to delete a rate option	<a href="#">Deleting a Rate Option</a> on page 2331
How to view the details of a rate option	<a href="#">Viewing the Rate Option Details</a> on page 2332

## Extendable Lookup Value

The **Extendable Lookup Value** zone displays the details of the rate option. It contains the following sections:

- **Main** – Displays basic information about the rate option. It contains the following fields:

Field Name	Field Description
Rate Option	Displays the rate option.
Description	Displays the description of the rate option.
Override Description	Displays the overridden description of the rate option.
Detailed Description	Displays additional information about the rate option.
Status	Indicates the status of the rate option. The valid values are: <ul style="list-style-type: none"> <li>• Active</li> <li>• Inactive</li> </ul>

Field Name	Field Description
Rate Schedule	<p>Indicates the rate schedule that will be used while defining the price item pricing. It is the rate schedule which helps the system to create calculation lines for a transaction leg.</p> <p><b>Note:</b> It has a link. On clicking the link, the <b>Rate Schedule</b> screen appears where you can view the details of the respective rate schedule.</p>
Pricing Currency	Indicates the currency in which the price item pricing will be defined.
Print Zero	<p>Indicates whether zero pricing will be displayed in the bill. The valid values are:</p> <ul style="list-style-type: none"> <li>• Yes</li> <li>• No</li> </ul>
Ignore Transaction	<p>Indicates whether the transactions mapped to the price item will be ignored for billing. The valid values are:</p> <ul style="list-style-type: none"> <li>• Yes</li> <li>• No</li> </ul>
Aggregate Transaction	<p>Indicates whether the transactions mapped to the price item will be aggregated for billing. The valid values are:</p> <ul style="list-style-type: none"> <li>• Yes</li> <li>• No</li> </ul>
Aggregation Schedule	Indicates the aggregation schedule using which the transactions will be aggregated for billing.
Transaction Rating Criteria	<p>Indicates how and when the transaction legs which are mapped to the price item are rated. The valid values are:</p> <ul style="list-style-type: none"> <li>• Aggregate Transactions and Then Rate SQs</li> <li>• Do Not Rate Transactions</li> <li>• Rate Transaction and Aggregate Calc Lines</li> <li>• Rate Transactions</li> </ul>
Apply To	<p>Indicates whether the price item pricing will be applied to all customers or only to the new customers. The valid values are:</p> <ul style="list-style-type: none"> <li>• All Customers</li> <li>• New Customers</li> </ul>

- **Record Actions** – This section contains the following buttons:

Button Name	Button Description
Edit	Used to edit the details of the rate option.
Delete	<p>Used to delete the rate option.</p> <p><b>Note:</b> You can delete a rate option only when it is not yet used in a pricing rule type.</p>

Button Name	Button Description
Duplicate	Used to create a new rate option using an existing rate option.

- **Record Information** – This section contains the following fields:

Field Name	Field Description
Business Object	Indicates the extendable lookup business object using which the rate option is created. In addition, a context menu appears corresponding to this field which helps in navigating to other screens in the application.  <b>Note:</b> It has a link. On clicking the link, the <b>Business Object</b> screen appears where you can view the details of the respective business object.
Owner	Indicates who has created the rate option. The valid values are: <ul style="list-style-type: none"> <li>• Framework</li> <li>• Base</li> <li>• Customer Modification</li> </ul>

By default, the **Extendable Lookup Value** zone does not appear in the **Extendable Lookup** screen. It appears only when you click the **Broadcast**  icon corresponding to the rate option in the **Extendable Lookup Value List** zone.

#### Related Topics

For more information on...	See...
How to edit a rate option	<a href="#">Editing a Rate Option</a> on page 2326
How to copy a rate option	<a href="#">Copying a Rate Option</a> on page 2329
How to delete a rate option	<a href="#">Deleting a Rate Option</a> on page 2331
How to view the details of a rate option	<a href="#">Viewing the Rate Option Details</a> on page 2332

## Defining a Rate Option

### Prerequisites

To define a rate option, you should have:

- Rate schedules, currencies, and aggregation schedules defined in the application

### Procedure

To define a rate option:

1. Search for the **Rate Option** extendable lookup in the **Extendable Lookup Query** screen.
2. In the **Search Results** section, click the link in the **Description** column corresponding to the extendable lookup business object whose details you want to view.

The **Extendable Lookup** screen appears.

3. Click the **Add** button in the **Page Title** area of the **Extendable Lookup** screen.

The **Rate Option** screen appears. It contains the following section:

- **Main** – Used to specify basic details about the rate option. It contains the following fields:

Field Name	Field Description	Mandatory (Yes or No)
Rate Option	Used to specify the rate option.	Yes
Description	Used to specify the description for the rate option.	Yes
Override Description	Used when you want to override the description of the rate option.	No
Detailed Description	Used to specify additional information about the rate option.	No
Status	<p>Used to indicate the status of the rate option. The valid values are:</p> <ul style="list-style-type: none"> <li>• Active</li> <li>• Inactive</li> </ul> <p><b>Note:</b> By default, the value is set to <b>Active</b>.</p>	Yes
Rate Schedule	<p>Used to indicate the rate schedule that you want to use while defining the price item pricing. It is the rate schedule which helps the system to create calculation lines for a transaction leg.</p> <p><b>Note:</b> The <b>Search</b> (🔍) icon appears corresponding to this field. On clicking the <b>Search</b> icon, the <b>Rate Schedule Search</b> window appears.</p>	Yes
Pricing Currency	Used to indicate the currency in which you want to define the price item pricing.	Yes
Print Zero	<p>Used to indicate whether zero pricing should be displayed in the bill. The valid values are:</p> <ul style="list-style-type: none"> <li>• Yes</li> <li>• No</li> </ul> <p><b>Note:</b> By default, the value is set to <b>Yes</b>.</p>	Yes
Ignore Transaction	<p>Used to indicate whether the transactions mapped to the price item should be ignored for billing. The valid values are:</p> <ul style="list-style-type: none"> <li>• Yes</li> <li>• No</li> </ul> <p><b>Note:</b> By default, the value is set to <b>No</b>.</p>	Yes

Field Name	Field Description	Mandatory (Yes or No)
Aggregate Transaction	<p>Used to indicate whether the transactions mapped to the price item should be aggregated for billing. The valid values are:</p> <ul style="list-style-type: none"> <li>• Yes</li> <li>• No</li> </ul> <div data-bbox="597 415 1127 611" style="border: 1px solid black; padding: 5px;"> <p><b>Note:</b> By default, the value is set to <b>No</b>. This field is disabled when the <b>Ignore Transaction</b> field is set to <b>Yes</b>.</p> </div>	Yes
Aggregation Schedule	<p>Used to indicate the aggregation schedule using which the transactions should be aggregated for billing.</p> <div data-bbox="597 751 1127 835" style="border: 1px solid black; padding: 5px;"> <p><b>Note:</b> This field is disabled when the <b>Ignore Transaction</b> field is set to <b>Yes</b>.</p> </div>	Yes (Conditional)  <div data-bbox="1144 688 1463 835" style="border: 1px solid black; padding: 5px;"> <p><b>Note:</b> This field is required when the <b>Aggregate Transaction</b> field is set to <b>Yes</b>.</p> </div>
Transaction Rating Criteria	<p>Used to indicate how and when you want to rate the transaction legs which are mapped to the price item. The valid values are:</p> <ul style="list-style-type: none"> <li>• Aggregate Transactions and Then Rate SQs</li> </ul> <div data-bbox="662 1024 1127 1171" style="border: 1px solid black; padding: 5px;"> <p><b>Note:</b> This value appears in the list only when the <b>Ignore Transaction</b> field is set to <b>No</b> and the <b>Aggregate Transaction</b> field is set to <b>Yes</b>.</p> </div> <ul style="list-style-type: none"> <li>• Do Not Rate Transactions</li> <li>• Rate Transaction and Aggregate Calc Lines</li> </ul> <div data-bbox="662 1283 1127 1430" style="border: 1px solid black; padding: 5px;"> <p><b>Note:</b> This value appears in the list only when the <b>Ignore Transaction</b> field is set to <b>No</b> and the <b>Aggregate Transaction</b> field is set to <b>Yes</b>.</p> </div> <ul style="list-style-type: none"> <li>• Rate Transactions</li> </ul> <div data-bbox="662 1493 1127 1640" style="border: 1px solid black; padding: 5px;"> <p><b>Note:</b> This value appears in the list only when the <b>Ignore Transaction</b> field is set to either <b>Yes</b> or <b>No</b> and the <b>Aggregate Transaction</b> field is set to <b>No</b>.</p> </div> <div data-bbox="597 1661 1127 1745" style="border: 1px solid black; padding: 5px;"> <p><b>Note:</b> By default, the value is set to <b>Do Not Rate Transactions</b>.</p> </div>	Yes

Field Name	Field Description	Mandatory (Yes or No)
Apply To	Used to indicate whether you want the price item pricing to be applied to all customers or only to the new customers. The valid values are: <ul style="list-style-type: none"> <li>All Customers</li> <li>New Customers</li> </ul> <div style="border: 1px solid black; padding: 2px; margin-top: 5px;"> <b>Note:</b> By default, the value is set to <b>All Customers</b>. </div>	Yes

4. Enter the required details in the **Main** section.

5. Click **Save**.

The rate option is added in the **C1-ExtLookRetTypeRateOpt** extendable lookup.

### Related Topics

For more information on...	See...
How to search for the <b>Rate Option</b> extendable lookup	<a href="#">Searching for the Rate Option Extendable Lookup</a> on page 2319
<b>Extendable Lookup</b> screen	<a href="#">Extendable Lookup (Rate Option)</a> on page 2320

## Editing a Rate Option

### Prerequisites

To edit a rate option, you should have:

- Rate schedules, currencies, and aggregation schedules defined in the application

### Procedure

To edit a rate option:

- Search for the **Rate Option** extendable lookup in the **Extendable Lookup Query** screen.
- In the **Search Results** section, click the link in the **Description** column corresponding to the extendable lookup business object whose details you want to view.

The **Extendable Lookup** screen appears.

- In the **Extendable Lookup Value List** zone, click the **Edit** (✎) icon in the **Edit** column corresponding to the rate option whose details you want to edit.

The **Rate Option** screen appears. It contains the following section:

- Main** – Used to specify basic details about the rate option. It contains the following fields:

Field Name	Field Description	Mandatory (Yes or No)
Rate Option	Displays the rate option.	Not applicable
Description	Used to specify the description for the rate option.	Yes
Override Description	Used when you want to override the description of the rate option.	No
Detailed Description	Used to specify additional information about the rate option.	No

Field Name	Field Description	Mandatory (Yes or No)
Status	Used to indicate the status of the rate option. The valid values are: <ul style="list-style-type: none"> <li>Active</li> <li>Inactive</li> </ul>	Yes
Owner	Indicates who has created the rate option. The valid values are: <ul style="list-style-type: none"> <li>Framework</li> <li>Base</li> <li>Customer Modification</li> </ul>	Not applicable
Rate Schedule	Used to indicate the rate schedule that you want to use while defining the price item pricing. It is the rate schedule which helps the system to create calculation lines for a transaction leg. <div style="border: 1px solid black; padding: 5px; margin-top: 10px;"> <p><b>Note:</b> The <b>Search</b> (🔍) icon appears corresponding to this field. On clicking the <b>Search</b> icon, the <b>Rate Schedule Search</b> window appears.</p> </div>	Yes
Pricing Currency	Used to indicate the currency in which you want to define the price item pricing.	Yes
Print Zero	Used to indicate whether zero pricing should be displayed in the bill. The valid values are: <ul style="list-style-type: none"> <li>Yes</li> <li>No</li> </ul>	Yes
Ignore Transaction	Used to indicate whether the transactions mapped to the price item should be ignored for billing. The valid values are: <ul style="list-style-type: none"> <li>Yes</li> <li>No</li> </ul>	Yes
Aggregate Transaction	Used to indicate whether the transactions mapped to the price item should be aggregated for billing. The valid values are: <ul style="list-style-type: none"> <li>Yes</li> <li>No</li> </ul> <div style="border: 1px solid black; padding: 5px; margin-top: 10px;"> <p><b>Note:</b> This field is disabled when the <b>Ignore Transaction</b> field is set to <b>Yes</b>.</p> </div>	Yes

Field Name	Field Description	Mandatory (Yes or No)
Aggregation Schedule	Used to indicate the aggregation schedule using which the transactions should be aggregated for billing.  <b>Note:</b> This field is disabled when the <b>Ignore Transaction</b> field is set to <b>Yes</b> .	Yes (Conditional)  <b>Note:</b> This field is required when the <b>Aggregate Transaction</b> field is set to <b>Yes</b> .
Transaction Rating Criteria	Used to indicate how and when you want to rate the transaction legs which are mapped to the price item. The valid values are: <ul style="list-style-type: none"> <li>Aggregate Transactions and Then Rate SQs <b>Note:</b> This value appears in the list only when the <b>Ignore Transaction</b> field is set to <b>No</b> and the <b>Aggregate Transaction</b> field is set to <b>Yes</b>.</li> <li>Do Not Rate Transactions</li> <li>Rate Transaction and Aggregate Calc Lines <b>Note:</b> This value appears in the list only when the <b>Ignore Transaction</b> field is set to <b>No</b> and the <b>Aggregate Transaction</b> field is set to <b>Yes</b>.</li> <li>Rate Transactions <b>Note:</b> This value appears in the list only when the <b>Ignore Transaction</b> field is set to either <b>Yes</b> or <b>No</b> and the <b>Aggregate Transaction</b> field is set to <b>No</b>.</li> </ul>	Yes
Apply To	Used to indicate whether you want the price item pricing to be applied to all customers or only to the new customers. The valid values are: <ul style="list-style-type: none"> <li>All Customers</li> <li>New Customers</li> </ul>	Yes

**Tip:** Alternatively, you can edit the details of a rate option by clicking the **Edit** button in the **Extendable Lookup Value** zone.

4. Modify the required details in the **Main** section.
5. Click **Save**.

The changes made to the rate option are saved.

### **Related Topics**

For more information on...	See...
How to search for the <b>Rate Option</b> extendable lookup	<a href="#">Searching for the Rate Option Extendable Lookup</a> on page 2319
<b>Extendable Lookup</b> screen	<a href="#">Extendable Lookup (Rate Option)</a> on page 2320



For more information on...	See...
<b>Extendable Lookup Value List</b> zone	<a href="#">Extendable Lookup Value List</a> on page 2320
<b>Extendable Lookup Value</b> zone	<a href="#">Extendable Lookup Value</a> on page 2321

## Copying a Rate Option

Instead of creating a rate option from scratch, you can create a new rate option using an existing rate option. This is possible through copying a rate option. On copying a rate option, the pricing and transaction aggregation details are copied to the new rate option. You can then edit the details, if required.

### Prerequisites

To copy a rate option, you should have:

- Rate option (whose copy you want to create) defined in the application
- Rate schedules, currencies, and aggregation schedules defined in the application

### Procedure

To copy a rate option:

1. Search for the **Rate Option** extendable lookup in the **Extendable Lookup Query** screen.
2. In the **Search Results** section, click the link in the **Description** column corresponding to the extendable lookup business object whose details you want to view.

The **Extendable Lookup** screen appears.

3. In the **Extendable Lookup Value List** zone, click the **Duplicate** () icon in the **Duplicate** column corresponding to the rate option whose copy you want to create.

The **Rate Option** screen appears. It contains the following section:

- **Main** – Used to specify basic details about the rate option. It contains the following fields:

Field Name	Field Description	Mandatory (Yes or No)
Rate Option	Used to specify the rate option.	Yes
Description	Used to specify the description for the rate option.	Yes
Override Description	Used when you want to override the description of the rate option.	No
Detailed Description	Used to specify additional information about the rate option.	No
Status	Used to indicate the status of the rate option. The valid values are: <ul style="list-style-type: none"> <li>• Active</li> <li>• Inactive</li> </ul>	Yes

Field Name	Field Description	Mandatory (Yes or No)
Rate Schedule	<p>Used to indicate the rate schedule that you want to use while defining the price item pricing. It is the rate schedule which helps the system to create calculation lines for a transaction leg.</p> <p><b>Note:</b> The <b>Search</b> (🔍) icon appears corresponding to this field. On clicking the <b>Search</b> icon, the <b>Rate Schedule Search</b> window appears.</p>	Yes
Pricing Currency	Used to indicate the currency in which you want to define the price item pricing.	Yes
Print Zero	<p>Used to indicate whether zero pricing should be displayed in the bill. The valid values are:</p> <ul style="list-style-type: none"> <li>• Yes</li> <li>• No</li> </ul>	Yes
Ignore Transaction	<p>Used to indicate whether the transactions mapped to the price item should be ignored for billing. The valid values are:</p> <ul style="list-style-type: none"> <li>• Yes</li> <li>• No</li> </ul>	Yes
Aggregate Transaction	<p>Used to indicate whether the transactions mapped to the price item should be aggregated for billing. The valid values are:</p> <ul style="list-style-type: none"> <li>• Yes</li> <li>• No</li> </ul> <p><b>Note:</b> This field is disabled when the <b>Ignore Transaction</b> field is set to <b>Yes</b>.</p>	Yes
Aggregation Schedule	<p>Used to indicate the aggregation schedule using which the transactions should be aggregated for billing.</p> <p><b>Note:</b> This field is disabled when the <b>Ignore Transaction</b> field is set to <b>Yes</b>.</p>	<p>Yes (Conditional)</p> <p><b>Note:</b> This field is required when the <b>Aggregate Transaction</b> field is set to <b>Yes</b>.</p>

Field Name	Field Description	Mandatory (Yes or No)
Transaction Rating Criteria	<p>Used to indicate how and when you want to rate the transaction legs which are mapped to the price item. The valid values are:</p> <ul style="list-style-type: none"> <li>Aggregate Transactions and Then Rate SQs</li> </ul> <div style="border: 1px solid black; padding: 2px;"> <p><b>Note:</b> This value appears in the list only when the <b>Ignore Transaction</b> field is set to <b>No</b> and the <b>Aggregate Transaction</b> field is set to <b>Yes</b>.</p> </div> <ul style="list-style-type: none"> <li>Do Not Rate Transactions</li> <li>Rate Transaction and Aggregate Calc Lines</li> </ul> <div style="border: 1px solid black; padding: 2px;"> <p><b>Note:</b> This value appears in the list only when the <b>Ignore Transaction</b> field is set to <b>No</b> and the <b>Aggregate Transaction</b> field is set to <b>Yes</b>.</p> </div> <ul style="list-style-type: none"> <li>Rate Transactions</li> </ul> <div style="border: 1px solid black; padding: 2px;"> <p><b>Note:</b> This value appears in the list only when the <b>Ignore Transaction</b> field is set to either <b>Yes</b> or <b>No</b> and the <b>Aggregate Transaction</b> field is set to <b>No</b>.</p> </div>	Yes
Apply To	<p>Used to indicate whether you want the price item pricing to be applied to all customers or only to the new customers. The valid values are:</p> <ul style="list-style-type: none"> <li>All Customers</li> <li>New Customers</li> </ul>	Yes

**Tip:** Alternatively, you can copy a rate option by clicking the **Duplicate** button in the **Extendable Lookup Value** zone.

- Enter the required details in the **Main** section.
- Click **Save**.

The new rate option is added in the **C1-ExtLookRetTypeRateOpt** extendable lookup.

### **Related Topics**

For more information on...	See...
How to search for the <b>Rate Option</b> extendable lookup	<a href="#">Searching for the Rate Option Extendable Lookup</a> on page 2319
<b>Extendable Lookup</b> screen	<a href="#">Extendable Lookup (Rate Option)</a> on page 2320
<b>Extendable Lookup Value List</b> zone	<a href="#">Extendable Lookup Value List</a> on page 2320
<b>Extendable Lookup Value</b> zone	<a href="#">Extendable Lookup Value</a> on page 2321

## Deleting a Rate Option

### Procedure

To delete a rate option:

1. Search for the **Rate Option** extendable lookup in the **Extendable Lookup Query** screen.
2. In the **Search Results** section, click the link in the **Description** column corresponding to the extendable lookup business object whose details you want to view.

The **Extendable Lookup** screen appears.

3. In the **Extendable Lookup Value List** zone, click the **Delete** (🗑️) icon in the **Delete** column corresponding to the rate option that you want to delete.

A message appears confirming whether you want to delete the rate option.

**Note:** You can delete a rate option only when it is not yet used in a pricing rule type.

**Tip:** Alternatively, you can delete a rate option by clicking the **Delete** button in the **Extendable Lookup Value** zone.

4. Click **OK**.

The rate option is deleted from the **C1-ExtLookRefTypeRateOpt** extendable lookup.

### Related Topics

For more information on...	See...
How to search for the <b>Rate Option</b> extendable lookup	<a href="#">Searching for the Rate Option Extendable Lookup</a> on page 2319
<b>Extendable Lookup</b> screen	<a href="#">Extendable Lookup (Rate Option)</a> on page 2320
<b>Extendable Lookup Value List</b> zone	<a href="#">Extendable Lookup Value List</a> on page 2320
<b>Extendable Lookup Value</b> zone	<a href="#">Extendable Lookup Value</a> on page 2321

## Viewing the Rate Option Details

### Procedure

To view the details of a rate option:

1. Search for the **Rate Option** extendable lookup in the **Extendable Lookup Query** screen.
2. In the **Search Results** section, click the link in the **Description** column corresponding to the extendable lookup business object whose details you want to view.

The **Extendable Lookup** screen appears.

3. In the **Extendable Lookup Value List** zone, click the **Broadcast** (📡) icon corresponding to the rate option whose details you want to view.

The **Extendable Lookup Value** zone appears.

4. View the details of the rate option in the **Extendable Lookup Value** zone.

### Related Topics

For more information on...	See...
How to search for the <b>Rate Option</b> extendable lookup	<a href="#">Searching for the Rate Option Extendable Lookup</a> on page 2319
<b>Extendable Lookup</b> screen	<a href="#">Extendable Lookup (Rate Option)</a> on page 2320

For more information on...	See...
Extendable Lookup Value List zone	<a href="#">Extendable Lookup Value List</a> on page 2320
Extendable Lookup Value zone	<a href="#">Extendable Lookup Value</a> on page 2321

## Pricing Group

Oracle Revenue Management and Billing enables you to create pricing groups for a bill group. It consists of one or more rules. Each rule has a unique priority. A rule contains one or more criteria. Each criterion can contain the following:

- **Source System** - Indicates the external system from where the claim or enrollment transaction is received.
- **Parameter 1, Parameter 2, Parameter 3, and Parameter 4** - Indicates employee attributes based on which you want to define the pricing.

Note that the source system and parameter 1 are mandatory when you are defining a criterion in a rule. In the **Parameter 1** field, you can only specify the employee attribute which is defined for the bill group and source system combination in the **Bill Group Derivation and Pricing Parameters** zone.

You can specify multiple parameter 2, parameter 3, and parameter 4 combinations in the criterion. You can also specify multiple source system, parameter 1, parameter 2, parameter 3, and parameter 4 combinations (i.e. multiple criteria) in a rule. Once a pricing group is defined for a bill group, you can then use the pricing group while defining a pricing rule for the bill group. This enables you to define various rates for employees with different set of attributes. For example, in a claim pricing rule, you can maintain different markup and markdown values for employees who belong to the Western, Eastern, and Central location of United States.

You can define, edit, copy, and delete a pricing group through the **Bill Group Pricing Groups** zone in the **Pricing** tab of the **Customer 360° Information** screen.

## Viewing the Pricing Groups of a Bill Group

### Procedure

To view the pricing groups of a bill group:

1. Search for a bill group whose is associated with a self-funded policy in the **Customer 360° View** screen.
2. In the **Search Results** section, click the **View** () icon corresponding to the bill group whose details you want to view.

The **Person** tab appears in the **Customer 360° Information** screen.

3. Click the **Pricing** tab.

The **Pricing** tab appears.

4. In the **Bill Group ASO Policy Information** zone, click the **Broadcast** () icon corresponding to a bill group whose pricing groups you want to view.

The **Bill Group ASO Policy Pricing Rules** and **Bill Group Pricing Groups** zones appear.

5. View the pricing groups which are defined for the bill group and are currently active in the **Bill Group Pricing Groups** zone.

### Related Topics

For more information on...	See...
How to search for a person	<a href="#">Searching for a Person</a> on page 185
<b>Customer 360° Information</b> screen	<a href="#">Customer 360° Information</a> on page 196

For more information on...	See...
Pricing tab	<a href="#">Customer 360° Information - Pricing</a> on page 229
Bill Group ASO Policy Information zone	<a href="#">Bill Group ASO Policy Information</a> on page 236
Bill Group Pricing Groups zone	<a href="#">Bill Group Pricing Groups</a> on page 242

## Defining a Pricing Group for a Bill Group

### Prerequisites

To define a pricing group for a bill group, you should have:

- Values defined for the **C1-SourceSystemLookup** extendable lookup

### Procedure

To define a pricing group for a bill group:

1. Search for the Administrative Services Only (ASO) person in the **Customer 360° View** screen.
2. In the **Search Results** section, click the **View** () icon corresponding to the person whose details you want to view.

The **Person** tab in the **Customer 360° Information** screen appears.

3. Click the **Pricing** tab.

The **Pricing** tab appears.

4. In the **Bill Group ASO Policy Information** zone, click the **Broadcast** () icon corresponding to a bill group for whom you want to define a pricing group.

The **Bill Group ASO Policy Pricing Rules** and **Bill Group Pricing Groups** zones appear.

5. Click the **Add** link in the upper right corner of the **Bill Group Pricing Groups** zone.

The **Pricing Group** screen appears. It contains the following sections:

- **Main** – Used to specify basic details about the pricing group. It contains the following fields:

Field Name	Field Description	Mandatory (Yes or No)
Bill Group Information	Indicates the bill group for whom you want to define the pricing group.	Not applicable
Status	Used to indicate the status of the pricing group. The valid values are: <ul style="list-style-type: none"> <li>• Active</li> <li>• Inactive</li> </ul>	Yes
Description	Used to specify the description for the pricing group.	Yes

- **Pricing Group Rules** – Used to define rules in the pricing group. It contains the following fields in a grid:

Field Name	Field Description	Mandatory (Yes or No)
Priority	Used to indicate the order in which the rule should be executed while determining the pricing for the price item.  <b>Note:</b> You cannot define multiple rules in the pricing group with the same priority.	Yes
Rule	Used to specify the rule in the pricing group.	Yes
Description	Used to specify the description for the pricing group rule.	Yes
Criteria	On clicking the <b>Add</b> (  ) icon, you can define criteria for the pricing group rule.	Not applicable

6. Enter the required details in the **Main** section.
7. Define the required rules in the **Pricing Group Rules** section.
8. Click the **Add** (  ) icon in the **Criteria** field corresponding to the pricing group rule for which you want to define the criteria.

The following fields appear in another grid:

Field Name	Field Description	Mandatory (Yes or No)
Source System	Used to indicate the external system from where the claim or enrollment transaction is received.	Yes
Parameter 1	Used to specify the employee attribute based on which you want to define the pricing.  <b>Note:</b> You can only specify the employee attribute which is defined for the bill group and source system combination in the <b>Bill Group Derivation and Pricing Parameters</b> zone. You must not specify the ampersand (&) character in this field.  The <b>Search</b> (  ) icon appears corresponding to this field. On clicking the <b>Search</b> icon, the <b>Parameter 1 List for Bill Group</b> window appears.	Yes
Parameter 2	Used to specify the employee attribute based on which you want to define the pricing.  <b>Note:</b> You must not specify the ampersand (&) character in this field.	No
Parameter 3	Used to specify the employee attribute based on which you want to define the pricing.  <b>Note:</b> You must not specify the ampersand (&) character in this field.	No

Field Name	Field Description	Mandatory (Yes or No)
Parameter 4	Used to specify the employee attribute based on which you want to define the pricing.  <b>Note:</b> You must not specify the ampersand (&) character in this field.	No

9. Enter the source system and parameter 1 in the pricing group rule criteria.

**Note:** You must define at least one rule in the pricing group and at least one source system and parameter 1 combination in the pricing group rule.

10. If required, enter the parameter 2, parameter 3, and parameter 4 for the source system and parameter 1 combination in the pricing group rule criteria.

11. If you want to define more than one parameter 2, parameter 3, and parameter 4 for the source system and parameter 1 combination, click the **Add** (+) icon corresponding to the **Parameter 2** field and then repeat step 10.

**Note:** However, if you want to remove a parameter 2, parameter 3, and parameter 4 from the source system and parameter 1 combination, click the **Delete** (🗑️) icon corresponding to the parameter 2, parameter 3, and parameter 4.

12. If you want to define more than one source system and parameter 1 combination in the pricing group rule, click the **Add** (+) icon corresponding to the **Source System** field and then repeat step 9 and 10.

**Note:** However, if you want to remove a source system and parameter 1 combination from the pricing group rule, click the **Delete** (🗑️) icon corresponding to the combination.

13. If you want to define more than one rule in the pricing group, click the **Add** (+) icon corresponding to the **Priority** field and then repeat the steps from 7 to 10.

**Note:** However, if you want to remove a rule from the pricing group, click the **Delete** (🗑️) icon corresponding to the pricing group rule.

14. Click **Save**.

The pricing group is defined for the bill group.

### **Related Topics**

For more information on...	See...
How to search for a person	<a href="#">Searching for a Person</a> on page 185
<b>Customer 360° Information</b> screen	<a href="#">Customer 360° Information</a> on page 196
<b>Pricing</b> tab	<a href="#">Customer 360° Information - Pricing</a> on page 229
<b>Bill Group ASO Policy Information</b> zone	<a href="#">Bill Group ASO Policy Information</a> on page 236
<b>Bill Group Pricing Groups</b> zone	<a href="#">Bill Group Pricing Groups</a> on page 242
<b>Bill Group Derivation and Pricing Parameters</b> zone	<a href="#">Bill Group Derivation and Pricing Parameters</a> on page 208



## Editing a Pricing Group of a Bill Group

### Prerequisites

To edit a pricing group of a bill group, you should have:

- Values defined for the **C1-SourceSystemLookup** extendable lookup

### Procedure

To edit a pricing group of a bill group:

1. Search for the Administrative Services Only (ASO) person in the **Customer 360° View** screen.
2. In the **Search Results** section, click the **View** () icon corresponding to the person whose details you want to view.

The **Person** tab in the **Customer 360° Information** screen appears.

3. Click the **Pricing** tab.

The **Pricing** tab appears.

4. In the **Bill Group ASO Policy Information** zone, click the **Broadcast** () icon corresponding to a bill group whose pricing group you want to edit.

The **Bill Group ASO Policy Pricing Rules** and **Bill Group Pricing Groups** zones appear.

5. In the **Bill Group Pricing Groups** zone, click the **Edit** () icon in the **Edit** column corresponding to the pricing group whose details you want to edit.

The **Pricing Group** screen appears. It contains the following sections:

- **Main** – Used to specify basic details about the pricing group. It contains the following fields:

Field Name	Field Description	Mandatory (Yes or No)
Bill Group Information	Indicates the bill group for whom you want to define the pricing group.	Not applicable
Status	Used to indicate the status of the pricing group. The valid values are: <ul style="list-style-type: none"> <li>• Active</li> <li>• Inactive</li> </ul>	Yes
Description	Used to specify the description for the pricing group.	Yes

- **Pricing Group Rules** – Used to define rules in the pricing group. It contains the following fields in a grid:

Field Name	Field Description	Mandatory (Yes or No)
Priority	Used to indicate the order in which the rule should be executed while determining the pricing for the price item.  <b>Note:</b> You cannot define multiple rules in the pricing group with the same priority.	Yes
Rule	Used to specify the rule in the pricing group.	Yes
Description	Used to specify the description for the pricing group rule.	Yes

Field Name	Field Description	Mandatory (Yes or No)
Criteria	On clicking the <b>Add</b> (  ) icon, you can define criteria for the pricing group rule.	Not applicable

**Note:** You cannot define, edit, or remove a rule when the pricing group is already used while defining a pricing rule for the bill group.

6. Modify the required details in the **Main** section.
7. Edit the required rules in the **Pricing Group Rules** section.
8. Click the **Add** () icon in the **Criteria** field corresponding to the pricing group rule for which you want to edit the criteria.

The following fields appear in another grid:

Field Name	Field Description	Mandatory (Yes or No)
Source System	Used to indicate the external system from where the claim or enrollment transaction is received.	Yes
Parameter 1	Used to specify the employee attribute based on which you want to define the pricing.  <b>Note:</b> You can only specify the employee attribute which is defined for the bill group and source system combination in the <b>Bill Group Derivation and Pricing Parameters</b> zone. You must not specify the ampersand (&) character in this field.  The <b>Search</b> (  ) icon appears corresponding to this field. On clicking the <b>Search</b> icon, the <b>Parameter 1 List for Bill Group</b> window appears.	Yes
Parameter 2	Used to specify the employee attribute based on which you want to define the pricing.  <b>Note:</b> You must not specify the ampersand (&) character in this field.	No
Parameter 3	Used to specify the employee attribute based on which you want to define the pricing.  <b>Note:</b> You must not specify the ampersand (&) character in this field.	No
Parameter 4	Used to specify the employee attribute based on which you want to define the pricing.  <b>Note:</b> You must not specify the ampersand (&) character in this field.	No

**Note:** You cannot define, edit, or remove the source system, parameter 1, parameter 2, parameter 3, and parameter 4 from a rule when the pricing group is already used while defining a pricing rule for the bill group.

9. If required, enter the source system and parameter 1 in the pricing group rule criteria.

**Note:** You must define at least one rule in the pricing group and at least one source system and parameter 1 combination in the pricing group rule.

10. If required, enter the parameter 2, parameter 3, and parameter 4 for the source system and parameter 1 combination in the pricing group rule criteria.

11. If you want to define more than one parameter 2, parameter 3, and parameter 4 for the source system and parameter 1 combination, click the **Add** (+) icon corresponding to the **Parameter 2** field and then repeat step 10.

**Note:** However, if you want to remove a parameter 2, parameter 3, and parameter 4 from the source system and parameter 1 combination, click the **Delete** (🗑️) icon corresponding to the parameter 2, parameter 3, and parameter 4.

12. If you want to define more than one source system and parameter 1 combination in the pricing group rule, click the **Add** (+) icon corresponding to the **Source System** field and then repeat step 9 and 10.

**Note:** However, if you want to remove a source system and parameter 1 combination from the pricing group rule, click the **Delete** (🗑️) icon corresponding to the combination.

13. If you want to define more than one rule in the pricing group, click the **Add** (+) icon corresponding to the **Priority** field and then repeat the steps from 7 to 10.

**Note:** However, if you want to remove a rule from the pricing group, click the **Delete** (🗑️) icon corresponding to the pricing group rule.

14. Click **Save**.

The changes made to the pricing group are saved.

### **Related Topics**

<b>For more information on...</b>	<b>See...</b>
How to search for a person	<a href="#">Searching for a Person</a> on page 185
<b>Customer 360° Information</b> screen	<a href="#">Customer 360° Information</a> on page 196
<b>Pricing</b> tab	<a href="#">Customer 360° Information - Pricing</a> on page 229
<b>Bill Group ASO Policy Information</b> zone	<a href="#">Bill Group ASO Policy Information</a> on page 236
<b>Bill Group Pricing Groups</b> zone	<a href="#">Bill Group Pricing Groups</a> on page 242
<b>Bill Group Derivation and Pricing Parameters</b> zone	<a href="#">Bill Group Derivation and Pricing Parameters</a> on page 208

## **Deleting a Pricing Group of a Bill Group**

### **Procedure**

To delete a pricing group of a bill group:

1. Search for the Administrative Services Only (ASO) person in the **Customer 360° View** screen.
2. In the **Search Results** section, click the **View** () icon corresponding to the person whose details you want to view.

The **Person** tab in the **Customer 360° Information** screen appears.

3. Click the **Pricing** tab.

The **Pricing** tab appears.

4. In the **Bill Group ASO Policy Information** zone, click the **Broadcast** () icon corresponding to a bill group whose pricing group you want to delete.

The **Bill Group ASO Policy Pricing Rules** and **Bill Group Pricing Groups** zones appear.

5. In the **Bill Group Pricing Groups** zone, click the **Delete** () icon in the **Delete** column corresponding to the pricing group that you want to delete.

A message appears confirming whether you want to delete the pricing group.

**Note:** You can delete a pricing group only when it is not yet used while defining a pricing rule for the bill group.

6. Click **OK**.

The pricing group is deleted.

### **Related Topics**

<b>For more information on...</b>	<b>See...</b>
How to search for a person	<a href="#">Searching for a Person</a> on page 185
<b>Customer 360° Information</b> screen	<a href="#">Customer 360° Information</a> on page 196
<b>Pricing</b> tab	<a href="#">Customer 360° Information - Pricing</a> on page 229
<b>Bill Group ASO Policy Information</b> zone	<a href="#">Bill Group ASO Policy Information</a> on page 236
<b>Bill Group Pricing Groups</b> zone	<a href="#">Bill Group Pricing Groups</a> on page 242

## **Copying a Pricing Group of a Bill Group**

Instead of creating a pricing group from scratch, you can create a new pricing group using an existing pricing group. This is possible through copying a pricing group. On copying a pricing group, the details including the rules are copied to the new pricing group. You can then edit the details, if required.

### **Prerequisites**

To copy a pricing group of a bill group, you should have:

- Pricing group (whose copy you want to create) defined in the application
- Values defined for the **C1-SourceSystemLookup** extendable lookup

### **Procedure**

To copy a pricing group of a bill group:

1. Search for the Administrative Services Only (ASO) person in the **Customer 360° View** screen.
2. In the **Search Results** section, click the **View** () icon corresponding to the person whose details you want to view.

The **Person** tab in the **Customer 360° Information** screen appears.

- Click the **Pricing** tab.

The **Pricing** tab appears.

- In the **Bill Group ASO Policy Information** zone, click the **Broadcast**  icon corresponding to a bill group whose pricing group you want to copy.

The **Bill Group ASO Policy Pricing Rules** and **Bill Group Pricing Groups** zones appear.

- In the **Bill Group Pricing Groups** zone, click the **Duplicate**  icon in the **Duplicate** column corresponding to the pricing group whose copy you want to create.

The **Pricing Group** screen appears. It contains the following sections:

- Main** – Used to specify basic details about the pricing group. It contains the following fields:

Field Name	Field Description	Mandatory (Yes or No)
Bill Group Information	Indicates the bill group for whom you want to define the pricing group.	Not applicable
Status	Used to indicate the status of the pricing group. The valid values are: <ul style="list-style-type: none"> <li>Active</li> <li>Inactive</li> </ul>	Yes
Description	Used to specify the description for the pricing group.	Yes

- Pricing Group Rules** – Used to define rules in the pricing group. It contains the following fields in a grid:

Field Name	Field Description	Mandatory (Yes or No)
Priority	Used to indicate the order in which the rule should be executed while determining the pricing for the price item. <div style="border: 1px solid black; padding: 2px; margin-top: 5px;"><b>Note:</b> You cannot define multiple rules in the pricing group with the same priority.</div>	Yes
Rule	Used to specify the rule in the pricing group.	Yes
Description	Used to specify the description for the pricing group rule.	Yes
Criteria	On clicking the <b>Add</b>  icon, you can define criteria for the pricing group rule.	Not applicable

- Enter the required details in the **Main** section.
- Define, edit, or remove the required rules from the **Pricing Group Rules** section.
- Click the **Add**  icon in the **Criteria** field corresponding to the pricing group rule for which you want to define or edit the criteria.

The following fields appear in another grid:

Field Name	Field Description	Mandatory (Yes or No)
Source System	Used to indicate the external system from where the claim or enrollment transaction is received.	Yes

Field Name	Field Description	Mandatory (Yes or No)
Parameter 1	<p>Used to specify the employee attribute based on which you want to define the pricing.</p> <p><b>Note:</b> You can only specify the employee attribute which is defined for the bill group and source system combination in the <b>Bill Group Derivation and Pricing Parameters</b> zone. You must not specify the ampersand (&amp;) character in this field. The <b>Search</b> () icon appears corresponding to this field. On clicking the <b>Search</b> icon, the <b>Parameter 1 List for Bill Group</b> window appears.</p>	Yes
Parameter 2	<p>Used to specify the employee attribute based on which you want to define the pricing.</p> <p><b>Note:</b> You must not specify the ampersand (&amp;) character in this field.</p>	No
Parameter 3	<p>Used to specify the employee attribute based on which you want to define the pricing.</p> <p><b>Note:</b> You must not specify the ampersand (&amp;) character in this field.</p>	No
Parameter 4	<p>Used to specify the employee attribute based on which you want to define the pricing.</p> <p><b>Note:</b> You must not specify the ampersand (&amp;) character in this field.</p>	No

9. Enter the source system and parameter 1 in the pricing group rule criteria.

**Note:** You must define at least one rule in the pricing group and at least one source system and parameter 1 combination in the pricing group rule.

10. If required, enter the parameter 2, parameter 3, and parameter 4 for the source system and parameter 1 combination in the pricing group rule criteria.
11. If you want to define more than one parameter 2, parameter 3, and parameter 4 for the source system and parameter 1 combination, click the **Add** () icon corresponding to the **Parameter 2** field and then repeat step 10.

**Note:** However, if you want to remove a parameter 2, parameter 3, and parameter 4 from the source system and parameter 1 combination, click the **Delete** () icon corresponding to the parameter 2, parameter 3, and parameter 4.

12. If you want to define more than one source system and parameter 1 combination in the pricing group rule, click the **Add** () icon corresponding to the **Source System** field and then repeat step 9 and 10.

**Note:** However, if you want to remove a source system and parameter 1 combination from the pricing group rule, click the **Delete** () icon corresponding to the combination.

13. If you want to define more than one rule in the pricing group, click the **Add** () icon corresponding to the **Priority** field and then repeat the steps from 7 to 10.

**Note:** However, if you want to remove a rule from the pricing group, click the **Delete** () icon corresponding to the pricing group rule.

14. Click **Save**.

The new pricing group is defined for the bill group.

### **Related Topics**

<b>For more information on...</b>	<b>See...</b>
How to search for a person	<a href="#">Searching for a Person</a> on page 185
<b>Customer 360° Information</b> screen	<a href="#">Customer 360° Information</a> on page 196
<b>Pricing</b> tab	<a href="#">Customer 360° Information - Pricing</a> on page 229
<b>Bill Group ASO Policy Information</b> zone	<a href="#">Bill Group ASO Policy Information</a> on page 236
<b>Bill Group Pricing Groups</b> zone	<a href="#">Bill Group Pricing Groups</a> on page 242
<b>Bill Group Derivation and Pricing Parameters</b> zone	<a href="#">Bill Group Derivation and Pricing Parameters</a> on page 208

## **Pricing Rule Type**

Pricing rules are created using pricing rule types. Following are the pricing rules:

- **Claim** – can be created using the claim pricing rule type.
- **Retention Type Claim Based** – can be created using the retention type claim base pricing rule type.
- **Retention Type Enrollment Based** – can be created using the retention type enrollment base pricing rule type.
- **Specific Stop-Loss** – can be created using the specific stop-loss pricing rule type.
- **Aggregated Stop-Loss** – can be created using the aggregated stop-loss or specific stop-loss pricing rule type.
- **One-Time Flat Fee** – can be created using the one-time flat fee pricing rule type.
- **Bill Period Based Recurring Flat Fee** – can be created using the bill period based recurring flat fee pricing rule type.
- **Frequency Based Recurring Flat Fee** – can be created using the frequency based recurring flat fee pricing rule type.

Pricing rule type has a parent business object, **C1-PricingRuleType** with all the common elements required for all pricing rule types. Elements that are specific to each pricing rule type are configured using the child business object. Following are the child business objects:

- **C1-PricingRuleTypeClaim** business object for Claim Pricing Rule Type.
- **C1-PrcRuleTypRetClaimBase** business object for Retention Claim Based Pricing Rule Type.
- **C1-PrcRuleTypRetEnrollBased** business object for Retention Enrollment Based Pricing Rule Type.

- **C1-PricingRuleTypeASL** business object for Aggregate Stop-Loss Pricing Rule Type.
- **C1-PricingRuleTypeSSL** business object for Specific Stop-Loss Pricing Rule Type.
- **C1-PricingRuleTypeFlatFees** business object for One-Time Flat Fee, Bill Period Based Recurring Flat Fee, Frequency Based Recurring Flat Fee Pricing Rule Types.



The **C1-GetPrcRuleTypeRateOpt** business service returns the list of rate options associated with a pricing rule type and selected price item. The **C1-GetPrcRuleTypeProd** business service returns the list of products associated with the pricing rule type.

This screen consists of the following zones:

- [Pricing Rule Type List](#) on page 2344
- [Pricing Rule Type](#) on page 2347

## Pricing Rule Type List

The **Pricing Rule Type List** zone lists the pricing rule types that are already defined in the system. It contains the following columns:

Column Name	Column Description
Pricing Rule Type	Displays the pricing rule type.
Description	Displays the description of the pricing rule type.
Pricing Rule Type Category	Indicates the category to which the pricing rule type belongs. The valid values are: <ul style="list-style-type: none"> <li>• Claim</li> <li>• Specific Stop-Loss</li> <li>• Aggregate Stop-Loss</li> <li>• Retention Type Claim Based</li> <li>• Retention Type Enrollment Based</li> <li>• Flat Fees</li> <li>• Ancillary</li> <li>• Discount Arrangement</li> <li>• Level Funded</li> <li>• Age Based</li> <li>• Tier Based</li> <li>• Pass-Through Billable Charge</li> </ul>
Edit	On clicking the <b>Edit</b> (  ) icon, the <b>Claim Pricing Rule Type, Specific Stop-Loss (SSL) Pricing Rule Type, Aggregate Stop-Loss (ASL) Pricing Rule Type, Retention Type Claim Based Pricing Rule Type, Retention Type Enrollment Based Pricing Rule Type, Flat Fees Pricing Rule Type, Ancillary Pricing Rule Type, Discount Arrangement Pricing Rule Type, Level Funded Pricing Rule Type, Age Based Pricing Rule Type, Tier Based Pricing Rule Type, or Pass-Through Billable Charge Pricing Rule Type</b> screen appears, based on the pricing rule type category, where you can edit the details of the respective pricing rule type.
Delete	On clicking the <b>Delete</b> (  ) icon, you can delete the pricing rule type. <div style="border: 1px solid black; padding: 5px; margin-top: 10px;"> <p><b>Note:</b> You can delete a pricing rule type only when it is not yet used in the system.</p> </div>



**Note:** Pagination is used to display limited number of records in this zone. You can use the navigation links, such as **Previous** and **Next** to navigate between pages.

On clicking the **Broadcast**  icon corresponding to a pricing rule type, the **Pricing Rule Type** zone appears with the details of the respective pricing rule type.

You can filter the list using the **Pricing Rule Type Category** field available in the **Filter** area. By default, the **Filter** area is hidden. You can view the **Filter** area by clicking the **Filters**  icon in the upper right corner of this zone.

### **Related Topics**

<b>For more information on...</b>	<b>See...</b>
How to edit a claim pricing rule type	<a href="#">Editing a Claim Pricing Rule Type</a> on page 2361
How to delete a claim pricing rule type	<a href="#">Deleting a Claim Pricing Rule Type</a> on page 2364
How to view the details of a claim pricing rule type	<a href="#">Viewing the Claim Pricing Rule Type Details</a> on page 2364
How to edit a specific stop-loss pricing rule type	<a href="#">Editing a Specific Stop-Loss (SSL) Pricing Rule Type</a> on page 2391
How to delete a specific stop-loss pricing rule type	<a href="#">Deleting a Specific Stop-Loss (SSL) Pricing Rule Type</a> on page 2394
How to view the details of a specific stop-loss pricing rule type	<a href="#">Viewing the Specific Stop-Loss (SSL) Pricing Rule Type Details</a> on page 2394
How to edit an aggregate stop-loss pricing rule type	<a href="#">Editing an Aggregate Stop-Loss (ASL) Pricing Rule Type</a> on page 2427
How to delete an aggregate stop-loss pricing rule type	<a href="#">Deleting an Aggregate Stop-Loss (ASL) Pricing Rule Type</a> on page 2430
How to view the details of an aggregate stop-loss pricing rule type	<a href="#">Viewing the Aggregate Stop-Loss (ASL) Pricing Rule Type Details</a> on page 2430
How to edit a retention type claim based pricing rule type	<a href="#">Editing a Retention Type Claim Based Pricing Rule Type</a> on page 2461
How to delete a retention type claim based pricing rule type	<a href="#">Deleting a Retention Type Claim Based Pricing Rule Type</a> on page 2463
How to view the details of a retention type claim based pricing rule type	<a href="#">Viewing the Retention Type Claim Based Pricing Rule Type Details</a> on page 2464
How to edit a retention type enrollment based pricing rule type	<a href="#">Editing a Retention Type Enrollment Based Pricing Rule Type</a> on page 2489
How to delete a retention type enrollment based pricing rule type	<a href="#">Deleting a Retention Type Enrollment Based Pricing Rule Type</a> on page 2492
How to view the details of a retention type enrollment based pricing rule type	<a href="#">Viewing the Retention Type Enrollment Based Pricing Rule Type Details</a> on page 2492
How to edit a one-time flat fee pricing rule type	<a href="#">Editing a One-Time Flat Fee Pricing Rule Type</a> on page 2518
How to delete a one-time flat fee pricing rule type	<a href="#">Deleting a One-Time Flat Fee Pricing Rule Type</a> on page 2521
How to view the details of a one-time flat fee pricing rule type	<a href="#">Viewing the One-Time Flat Fee Pricing Rule Type Details</a> on page 2522

<b>For more information on...</b>	<b>See...</b>
How to edit a bill period based recurring flat fee pricing rule type	<a href="#">Editing a Bill Period Based Recurring Flat Fee Pricing Rule Type</a> on page 2533
How to delete a bill period based recurring flat fee pricing rule type	<a href="#">Deleting a Bill Period Based Recurring Flat Fee Pricing Rule Type</a> on page 2536
How to view the details of a bill period based recurring flat fee pricing rule type	<a href="#">Viewing the Bill Period Based Recurring Flat Fee Pricing Rule Type Details</a> on page 2537
How to edit a frequency based recurring flat fee pricing rule type	<a href="#">Editing a Frequency Based Recurring Flat Fee Pricing Rule Type</a> on page 2548
How to delete a frequency based recurring flat fee pricing rule type	<a href="#">Deleting a Frequency Based Recurring Flat Fee Pricing Rule Type</a> on page 2551
How to view the details of a frequency based recurring flat fee pricing rule type	<a href="#">Viewing the Frequency Based Recurring Flat Fee Pricing Rule Type Details</a> on page 2551
How to edit an ancillary pricing rule type	<a href="#">Editing an Ancillary Pricing Rule Type</a> on page 2586
How to delete an ancillary pricing rule type	<a href="#">Deleting an Ancillary Pricing Rule Type</a> on page 2590
How to view the details of an ancillary pricing rule type	<a href="#">Viewing the Ancillary Pricing Rule Type Details</a> on page 2591
How to edit a discount arrangement pricing rule type	<a href="#">Editing a Discount Arrangement Pricing Rule Type</a> on page 2625
How to delete a discount arrangement pricing rule type	<a href="#">Deleting a Discount Arrangement Pricing Rule Type</a> on page 2628
How to view the details of a discount arrangement pricing rule type	<a href="#">Viewing the Discount Arrangement Pricing Rule Type Details</a> on page 2629
How to edit a level funded pricing rule type	<a href="#">Editing a Level Funded Pricing Rule Type</a> on page 2658
How to delete a level funded pricing rule type	<a href="#">Deleting a Level Funded Pricing Rule Type</a> on page 2661
How to view the details of a level funded pricing rule type	<a href="#">Viewing the Level Funded Pricing Rule Type Details</a> on page 2661
How to edit an age based pricing rule type	<a href="#">Editing an Age Based Pricing Rule Type</a> on page 2801
How to delete an age based pricing rule type	<a href="#">Deleting an Age Based Pricing Rule Type</a> on page 2803
How to view the details of an age based pricing rule type	<a href="#">Viewing the Age Based Pricing Rule Type Details</a> on page 2804
How to edit a tier based pricing rule type	<a href="#">Editing a Tier Based Pricing Rule Type</a> on page 2816
How to delete a tier based pricing rule type	<a href="#">Deleting a Tier Based Pricing Rule Type</a> on page 2818
How to view the details of a tier based pricing rule type	<a href="#">Viewing the Tier Based Pricing Rule Type Details</a> on page 2819
How to edit a pass-through billable charge pricing rule type	<a href="#">Editing a Pass-Through Billable Charge Pricing Rule Type</a> on page 2828
How to delete a pass-through billable charge pricing rule type	<a href="#">Deleting a Pass-Through Billable Charge Pricing Rule Type</a> on page 2830
How to view the details of a pass-through billable charge pricing rule type	<a href="#">Viewing the Pass-Through Billable Charge Pricing Rule Type Details</a> on page 2830

## Pricing Rule Type

The **Pricing Rule Type** zone displays the details of the pricing rule type for claim, aggregate stop-loss, specific stop-loss, retention type enrollment based, retention type claim based, one-time flat fee, bill period based recurring flat fee, frequency based recurring flat fee. This zone contains the following sections:

- **Main** – This section provides basic information about the pricing rule type. It contains the following fields:

Field Name	Field Description
Pricing Rule Type	Displays the pricing rule type.
Description	Displays the description for the pricing rule type.
Detailed Description	Displays additional information about the pricing rule type category.
Pricing Rule Business Object	<p>Indicates the pricing rule business object. In addition, a context menu appears corresponding to this field which helps in navigating to other screens in the application. The valid values are:</p> <ul style="list-style-type: none"> <li>• Claim Pricing Rule</li> <li>• Aggregate Stop-Loss (ASL) Pricing Rule</li> <li>• Specific Stop-Loss (SSL) Pricing Rule</li> <li>• Retention Type Claim Based Pricing Rule</li> <li>• Retention Type Enrollment Based Pricing Rule</li> <li>• Flat Fee Pricing Rule</li> </ul> <p><b>Note:</b> It has a link. On clicking the link, the <b>Business Object</b> screen appears where you can view the details of the respective business object.</p>
Business Object	<p>Indicates the pricing rule type business object. In addition, a context menu appears corresponding to this field which helps in navigating to other screens in the application. The valid values are:</p> <ul style="list-style-type: none"> <li>• Claim Pricing Rule Type</li> <li>• Aggregate Stop-Loss (ASL) Pricing Rule Type</li> <li>• Specific Stop-Loss (SSL) Pricing Rule Type</li> <li>• Retention Type Claim Based Pricing Rule Type</li> <li>• Retention Type Enrollment Based Pricing Rule Type</li> <li>• Flat Fee Pricing Rule Type</li> </ul> <p><b>Note:</b> It has a link. On clicking the link, the <b>Business Object</b> screen appears where you can view the details of the respective business object.</p>
Status	<p>Indicates the status of the pricing rule type. The valid values are:</p> <ul style="list-style-type: none"> <li>• Active</li> <li>• Inactive</li> </ul>
Primary	Displays whether the pricing rule type is primary or not.

Field Name	Field Description
Pricing Rule Type Category	Indicates the pricing rule type category for the pricing rule type. The valid values are: <ul style="list-style-type: none"> <li>• Claim</li> <li>• Aggregate Stop-Loss</li> <li>• Specific Stop-Loss</li> <li>• Retention Type Claim Based</li> <li>• Retention Type Enrollment Based</li> <li>• Flat Fees</li> </ul>

- **Related Pricing Rule Types** – This section lists the pricing rule types which are related to the parent pricing rule type. It contains the following columns:

Column Name	Column Description
Sequence	Displays the order in which pricing rule type is executed.
Pricing Rule Type	Displays the related pricing rule type for the parent rule type. <b>Note:</b> It has a link. On clicking the link, the <b>Pricing Rule Type</b> screen appears where you can view the details of the respective pricing rule type.

**Note:** This section appears only when the pricing rule type is a primary pricing rule type.

- **Transaction Field Mapping** – This section displays the transaction related data mapped to the pricing rule type. It contains the following fields:

Field Name	Field Description
Source System	Displays the external system from where the transaction data is mapped.
Parameter 1 ... Parameter 4	Displays the parameters mapped for the transactions.
Incurred Date	Displays the date incurred for transaction.
Paid Date	Displays the transaction paid date.
Source of Funds	Displays the source of funds used to make the payment.
Composite	Displays the composite transaction data.
Claim Disposition	Displays the disposition of the claims transaction.
Provider's Tax Identification Number	Displays the tax identification number of the provider.
Member ID	Displays the member ID.
Main Subscriber ID	Displays the customer ID.
Run-in Identifier	Displays the run-in identifier.
Runout Identifier	Displays the runout identifier.
Coverage Start Date	Displays the transaction coverage start date.
Coverage End Date	Displays the transaction coverage end date.

Field Name	Field Description
Retroactivity Indicator	Displays information of the retroactivity indicator.

**Note:** This section appears only when the pricing rule type is a primary pricing rule type.

- **Algorithms** – This section displays the algorithms used for the pricing rule type. It contains the following columns:



Column Name	Column Description
System Event	Indicates the system event on which the algorithm must be executed. The valid values are: <ul style="list-style-type: none"> <li>• Account and Price Item Derivation</li> <li>• Bill After Date Determination</li> <li>• Bill Group Derivation</li> <li>• Pricing Rule Post Processing</li> <li>• Transaction Validation</li> </ul>
Sequence	Displays the order in which the algorithms for each system event must be executed.
Algorithm	Displays the algorithm. <div style="border: 1px solid black; padding: 5px; margin-top: 10px;"> <p><b>Note:</b> It has a link. On clicking the link, the <b>Algorithm</b> screen appears with the details of the respective algorithm.</p> </div>

- **Additional Data** – This section displays the additional information about the pricing rule type. It contains the following fields:

Field Name	Field Description
Eligible for Level Funding	Indicates whether the pricing rule type is eligible for level funding or not. The valid values are: <ul style="list-style-type: none"> <li>• Yes</li> <li>• No</li> </ul>
Eligible for Specific Stop-Loss	Indicates whether the pricing rule type is eligible for specific stop-loss or not. The valid values are: <ul style="list-style-type: none"> <li>• Yes</li> <li>• No</li> </ul> <div style="border: 1px solid black; padding: 5px; margin-top: 10px;"> <p><b>Note:</b> This field appears only when the option selected for the <b>Pricing Rule Type Category</b> is <b>Claim, Retention Type Claim Based</b>, or <b>Retention Type Enrollment Based</b>.</p> </div>
Run-in Identifier Value	Displays the value for run-in identifier.
Runout Identifier Value	Displays the value for runout identifier.

**Note:** This section does not appear only when the pricing rule type category is flat fees.

- **Price Items** – This section displays the price items assigned to the pricing rule type. It contains the following columns:

Column Name	Column Description						
Price Item	<p>Displays the price item information.</p> <p><b>Note:</b> It has a link. On clicking the link, the <b>Price Item</b> screen appears where you can view the details of the respective price item.</p>						
Rate Option	<p>On clicking the <b>Add</b> (  ) icon, the following column appears:</p> <table border="1"> <thead> <tr> <th>Column Name</th> <th>Column Description</th> </tr> </thead> <tbody> <tr> <td>Rate Option</td> <td>Indicates the rate option for the price item.</td> </tr> </tbody> </table> <p><b>Note:</b> This column does not appear only when the pricing rule type category is flat fees.</p>	Column Name	Column Description	Rate Option	Indicates the rate option for the price item.		
Column Name	Column Description						
Rate Option	Indicates the rate option for the price item.						
Bill To Account	<p>On clicking the <b>Add</b> (  ) icon, the following columns appear:</p> <table border="1"> <thead> <tr> <th>Column Name</th> <th>Column Description</th> </tr> </thead> <tbody> <tr> <td>Priority</td> <td>Displays the order in which the invoice type was considered while defining a price item.</td> </tr> <tr> <td>Invoice Type</td> <td>Displays the invoice type for the price item.</td> </tr> </tbody> </table>	Column Name	Column Description	Priority	Displays the order in which the invoice type was considered while defining a price item.	Invoice Type	Displays the invoice type for the price item.
Column Name	Column Description						
Priority	Displays the order in which the invoice type was considered while defining a price item.						
Invoice Type	Displays the invoice type for the price item.						

- **Price Item Parameters** – This section displays the price item parameters in the pricing rule type. It contains the following columns:

Column Name	Column Description
Price Item Parameter	<p>Displays the parameter associated with the price item.</p> <p><b>Note:</b> It has a link. On clicking the link, the <b>Parameter</b> screen appears where you can view the details of the respective parameter.</p>
Transaction Field	<p>Displays the additional transaction data.</p> <p><b>Note:</b></p> <p>It has a link. On clicking the link, the <b>Field</b> screen appears where you can view the details of the respective transaction field.</p> <p>This column does not appear only when the pricing rule type category is flat fees.</p>
Eligible for Specific Stop-Loss	<p>Displays the parameter eligible for Specific Stop-Loss when the eligibility checkbox was checked.</p> <p><b>Note:</b> This field appears only when the option selected for the <b>Pricing Rule Type Category</b> is <b>Claim</b>, <b>Retention Type Claim Based</b>, or <b>Retention Type Enrollment Based</b>.</p>

Column Name	Column Description
Eligible for Level Funding	Displays the parameter eligible for level funding when the eligibility checkbox was checked.

- **Characteristics** – This section displays the pricing rule type characteristics. It contains the following columns:

Column Name	Column Description
Characteristic Type	Indicates the characteristic type.
Characteristic Value	Displays the value for the characteristic type.

- **Claim Templates** – This section list the pricing rule type for claim template. It contains the following field:

Field Name	Field Description
Claim Template	Indicates the claim template.

**Note:** This section appears only when the **Business Object** is **Claim Pricing Rule Type**.

- **Claim-Specific Additional Data** – This section displays the claim specific additional data. It contains the following fields:

Field Name	Field Description
Rule Based Billing Eligibility Field	Displays whether the rule based field is eligible for billing or not. <b>Note:</b> It has a link. On clicking the link, the <b>Field</b> screen appears where you can view the details of the respective field.
Rule Based Markup or Markdown Eligibility Field	Displays whether the rule based markup or markdown field is eligible for billing or not. <b>Note:</b> It has a link. On clicking the link, the <b>Field</b> screen appears where you can view the details of the respective field.
Markup or Markdown Billable Charge Line Type	Displays the markup or markdown billable charge line type.

**Note:** This section appears only when the **Business Object** is **Claim Pricing Rule Type**.

- **ASL-Specific Additional Data** – This section displays the Aggregated Stop-Loss specific additional data. It contains the following fields:

Field Name	Field Description
ASL Billable Charge Line Type	Displays the Aggregated Stop-Loss billable charge line type.
Domestic Provider Claim Billable Charge Line Type	Displays the claim billable charge line type for domestic provider.
Rule Based Domestic Provider Claim Eligibility Field	Displays the rule based domestic provider for claim eligibility field.
ASL Limit Price Item	Displays the Aggregated Stop-Loss limit price item.

Field Name	Field Description
Rule Based Billing Eligibility Field	Displays whether the rule based field is eligible for billing or not. <b>Note:</b> It has a link. On clicking the link, the <b>Field</b> screen appears where you can view the details of the respective field.
Rule Based Markup or Markdown Eligibility Field	Displays whether the rule based markup or markdown field is eligible for billing or not. <b>Note:</b> It has a link. On clicking the link, the <b>Field</b> screen appears where you can view the details of the respective field.
Markup or Markdown Billable Charge Line Type	Displays the markup or markdown billable charge line type.

**Note:** This section appears only when the **Business Object** is **Aggregate Stop-Loss (ASL) Pricing Rule Type**.

- **Enrollment-Specific Additional Data** – This section displays the enrollment specific additional data. It contains the following fields:

Field Name	Field Description
Retroactivity Indicator Value	Displays the value for the retroactivity indicator.

**Note:** This section appears only when the **Business Object** is **Retention Type Enrollment Based Pricing Rule Type**.

- **Claim Disposition Details** – This section displays the details of claim disposition. It contains the following columns:

Column Name	Column Description
Claim Disposition	Indicates the claim disposition.
Disposition Mode	Indicates the claim disposition mode. The valid values are: <ul style="list-style-type: none"> <li>• Align Signage</li> <li>• Zero Out</li> </ul>

**Note:** This section appears only when the **Business Object** is **Retention Type Claim Based Pricing Rule Type**.

- **SSL-Specific Additional Data** – This section displays the Specific Stop-Loss additional data. It contains the following fields:

Field Name	Field Description
SSL Billable Charge Line Type	Displays the Specific Stop-Loss billable charge line type.
Domestic Provider Claim Billable Charge Line Type	Displays the claim billable charge line type for domestic provider.
Rule Based Domestic Provider Claim Eligibility Field	Displays the rule based domestic provider for claim eligibility field.



Field Name	Field Description
Rule Based Billing Eligibility Field	Displays whether the rule based field is eligible for billing or not. <b>Note:</b> It has a link. On clicking the link, the <b>Field</b> screen appears where you can view the details of the respective field.
Rule Based Markup or Markdown Eligibility Field	Displays whether the rule based markup or markdown field is eligible for billing or not. <b>Note:</b> It has a link. On clicking the link, the <b>Field</b> screen appears where you can view the details of the respective field.
Markup or Markdown Billable Charge Line Type	Displays the markup or markdown billable charge line type.

**Note:** This section appears only when the **Business Object** is **Specific Stop-Loss (SSL) Pricing Rule Type**.

- **Billable Charge Line Types** – This section list the billable charge line type. It contains the following column:

Column Name	Column Description
Billable Charge Line Type	Indicates the billable charge line type.

**Note:** This section appears only when the **Business Object** is **Flat Fees Pricing Rule Type**.

- **Flat Fees - Specific Additional Data** – This section displays the recurring flat fee that is specific and considered as additional data. It contains the following fields:

Field Name	Field Description
Bill Segment Cancel Reason	Indicates the reason for cancelling the bill segment.
Recurring Fee	Displays whether the recurring flat fee is required or not.
Recurring Method	Indicates the recurring method if recurring fee is required. The valid values are: <ul style="list-style-type: none"> <li>• Bill Period</li> <li>• Frequency</li> </ul> <b>Note:</b> This field appears when the checkbox for <b>Recurring Fee</b> field is selected.

**Note:** This section appears only when the **Business Object** is **Flat Fees Pricing Rule Type**.

This section contains the following sub-section:

- **Bill Periods** – This section displays the bill period for the recurring flat fee. It contains the following column:

Column Name	Column Description
Bill Period	Indicates the bill period.

**Note:** This section appears when the **Recurring Method** is **Bill Period**.

- **Record Actions** – This section contains the following buttons:

Button Name	Button Description
Edit	Used to edit the details of the pricing rule type.
Delete	Used to delete the pricing rule type.

- **Record Information** – This section contains the following fields:

Field Name	Field Description
Business Object	Indicates the business object using which the extendable lookup value for pricing rule type is created. In addition, a context menu appears corresponding to this field which helps in navigating to other screens in the application.  <b>Note:</b> It has a link. On clicking the link, the <b>Business Object</b> screen appears with the details of the respective business object.

By default, the **Pricing Rule Type** zone does not appear in the **Pricing Rule Type** screen. It appears only when you click the **Broadcast**  icon corresponding to the pricing rule type in the **Pricing Rule Type List** zone.

### Related Topics

For more information on...	See...
<b>Pricing Rule Type</b> screen	<a href="#">Pricing Rule Type</a> on page 2343
<b>Pricing Rule Type List</b> zone	<a href="#">Pricing Rule Type List</a> on page 2344
How to edit the claim pricing rule type	<a href="#">Editing a Claim Pricing Rule Type</a> on page 2361
How to edit the specific stop-loss pricing rule type	<a href="#">Editing a Specific Stop-Loss (SSL) Pricing Rule Type</a> on page 2391
How to edit the aggregate stop-loss pricing rule type	<a href="#">Editing an Aggregate Stop-Loss (ASL) Pricing Rule Type</a> on page 2427
How to edit the retention type claim based pricing rule type	<a href="#">Editing a Retention Type Claim Based Pricing Rule Type</a> on page 2461
How to edit the retention type enrollment based pricing rule type	<a href="#">Editing a Retention Type Enrollment Based Pricing Rule Type</a> on page 2489
How to edit the one-time flat fee pricing rule type	<a href="#">Editing a One-Time Flat Fee Pricing Rule Type</a> on page 2518
How to edit the bill period based recurring flat fee pricing rule type	<a href="#">Editing a Bill Period Based Recurring Flat Fee Pricing Rule Type</a> on page 2533
How to edit the frequency based recurring flat fee pricing rule type	<a href="#">Editing a Frequency Based Recurring Flat Fee Pricing Rule Type</a> on page 2548
How to delete a pricing rule type	<a href="#">Deleting a Pricing Rule Type</a>

## Claim Pricing

The ASO service provider processes the claims as part of the ASO agreement and pays the claim amount to either hospital or main subscriber. The employer, in turn, reimburses the claim amount to the ASO service provider at the end of the bill period (i.e. typically, every month). Apart from charging the claim amount to the employer, the ASO service provider charges various additional fees, such as fee for network access, fee for non-network access, fee for collection services provided by external vendor, fee for hospital audit performed by external vendor, and so on.

Oracle Revenue Management and Billing allows the ASO service provider to bill the employers for the claim amount and various additional fees. You can use any custom mechanism or the file upload utility in ORMB to upload the claim transactions. The pricing for the claim transactions can be defined using the claim pricing rules. You can define a claim pricing rule at the parent customer and bill group levels. The claim pricing rule at the bill group level takes precedence over the claim pricing rule at the parent customer level. You can define claim pricing rules for parent customers and bill groups from the **Customer 360° Information** screen. You can define a claim pricing rule using a claim pricing rule type.

It is the claim pricing rule type which helps the system to determine:

- Business object using which the claim pricing rule should be created in the system.
- Whether it is the primary pricing rule type from where the related pricing rule types, such as specific stop-loss, aggregate stop-loss, and retention type claim based pricing rule types, will inherit the attributes.

**Note:** You must select the **Primary** option while defining a claim pricing rule type. On selecting the **Primary** option, the **Related Pricing Rule Types** and **Transaction Field Mapping** sections appear in the **Claim Pricing Rule Type** screen.

- Pricing rule types which are related to claim pricing rule type.
- Transaction fields from where the data for claim, specific stop-loss, aggregate stop-loss, retention type claim based processing should be retrieved.
- Algorithm which should be triggered while validating a transaction.

**Note:** An algorithm type for validating a transaction is not shipped from the product. You need to create a custom algorithm type, if required.

- Algorithms which should be triggered while deriving bill group, account, and price item for a transaction.

**Note:** You must create an algorithm using the **C1\_TXNBGDRV** algorithm type and attach it to the **Bill Group Derivation** system event. Similarly, you must create an algorithm using the **C1\_ACCPRIDRV** algorithm type and attach it to the **Account and Price Item Derivation** system event.

- Algorithm which should be triggered while determining the bill after date.

**Note:** You must create an algorithm using the **C1\_BAFTDRV** algorithm type and attach it to the **Bill After Date Determination** system event. The **C1\_BAFTDRV** algorithm sets the bill after date to the end date of the aggregation schedule which is specified in the respective rate option. For example, if the aggregation schedule is monthly, the bill after date is set to the last day of the month.

- Post-processing algorithm which should be triggered once the claim pricing rule is derived.

**Note:** A post-processing algorithm type is not shipped from the product. You need to create a custom algorithm type, if required.

- Price items for which you can define claim pricing rules using the claim pricing rule type.
- Rate options that you can use while defining the pricing for a price item.
- Different type of account to which the price item should be billed based on the specified priority.
- Price item parameters which you can use while accumulating specific stop-loss and aggregate stop-loss and while aggregating transactions.
- Claim templates which can be used while defining claim pricing rules using the claim pricing rule type.
- Additional information, such as:
  - Whether the price items included in the claim pricing rule type are eligible for specific stop-loss and aggregate stop-loss.
  - Identifiers which help to determine whether the claim transaction is received during the run-in period of the policy.

- Billable charge line type using which you want to create markup or markdown calculation lines.
- Transaction field which you want to use in the rules as the output parameter to determine whether the line item is eligible for billing.
- Transaction field which you want to use in the rules as the output parameter to determine whether the markup or markdown calculation line is eligible for billing.

Once a claim pricing rule type is defined, you can create claim pricing rules using the claim pricing rule type. While defining a claim pricing rule for a parent customer and bill group, you need to specify the following:

- Price item for which you want to define the pricing.
- Pricing date range during which the pricing is effective.
- Rate option and claim template which you want to use while defining the claim pricing.
- Whether you want to markup or markdown the various charges.
- Whether you want to use a flat amount for markup or markdown on overall charges.
- Whether you want to calculate markup or markdown amount based on percentage for each eligible charge.
- Whether a line item is eligible for billing when the billing eligibility for the line item in the claim template is set to **User Defined**.

**Note:** You can override the default markup and markdown values which are retrieved from the claim template.

In addition, while defining a claim pricing rule for a bill group, you need to specify the status of the policy for which you want to define the claim pricing rule. You can also specify a pricing group while defining a claim pricing rule for a bill group. If you specify a pricing group while defining a claim pricing rule for a bill group, you will have to define the following details for each rule defined in the pricing group:

- Whether you want to markup or markdown the various charges.
- Whether you want to use a flat amount for markup or markdown on overall charges.
- Whether you want to calculate markup or markdown amount based on percentage for each eligible charge.
- Whether a line item is eligible for billing when the billing eligibility for the line item in the claim template is set to **User Defined**.

Once a claim pricing rule is defined for a parent customer and bill group, the system creates one price assignment, one price list, and one price list assignment.

## Defining a Claim Pricing Rule Type

### Prerequisites

To define a claim pricing rule type, you should have:

- Business Object **C1-PricingRuleTypeClaim** defined for pricing rule type.
- Business Object **C1-PricingRuleClaim** defined for pricing rule.
- Pricing rule type category for claim defined in the application

### Procedure

To define a claim pricing rule type:

1. Click the **Admin** link in the **Application** toolbar.  
A list appears.
2. From the **Admin** menu, select **P** and then click **Pricing Rule Type**.  
A sub-menu appears.

- Click the **Add** option from the **Pricing Rule Type** sub-menu.

The **Select Business Object** screen appears. It contains the following field:

Field Name	Field Description	Mandatory (Yes or No)
Pricing Rule Type Business Object	Used to indicate the business object using which you want to create the pricing rule type.  <b>Note:</b> You can create a claim pricing rule type using the <b>Claim Pricing Rule Type</b> business object.	Yes

**Tip:** Alternatively, you can access this screen by clicking the **Add** button in the **Page Title** area of the **Pricing Rule Type** screen.

- Select the **Claim Pricing Rule Type** business object.
- Click **OK**.

The **Claim Pricing Rule Type** screen appears. It contains the following sections:

- Main** – Used to specify basic details about the claim pricing rule type.
- Related Pricing Rule Types** – Used to define the pricing rule types which are related to the parent pricing rule type.
- Transaction Field Mapping** – Used to specify the transaction related data mapped to the pricing rule type
- Algorithms** – Used to define the algorithms used for the pricing rule type.
- Additional Data** – Used to specify the additional information about the pricing rule type.
- Price Items** – Used to define the price items assigned to the pricing rule type.
- Price Item Parameters** – Used to define the price item parameters in the pricing rule type.
- Characteristics** – Used to define the characteristics for the pricing rule type.
- Claim Templates** – Used to define the pricing rule type for claim template.
- Claim-Specific Additional Data** – Used to specify the claim specific additional data.

The **Main** section contains the following fields:

Field Name	Field Description	Mandatory (Yes or No)
Pricing Rule Type	Used to specify the pricing rule type.	Yes
Description	Used to specify the description for the pricing rule type.	Yes
Detailed Description	Used to specify additional information about the pricing rule type.	No
Related Transaction Business Object	Used to indicate the pricing rule business object. The valid values are: <ul style="list-style-type: none"> <li>Claim Pricing Rule</li> <li>Aggregate Stop-Loss (ASL) Pricing Rule</li> <li>Specific Stop-Loss (SSL) Pricing Rule</li> <li>Retention Type Claim Based Pricing Rule</li> <li>Retention Type Enrollment Based Pricing Rule</li> </ul>	Yes

Field Name	Field Description	Mandatory (Yes or No)
Business Object	Indicate the pricing rule type business object for claim.	Not applicable
Status	Used to indicate the status of the pricing rule type. The valid values are: <ul style="list-style-type: none"> <li>Active</li> <li>Inactive</li> </ul>	Yes
Primary	Used to select the checkbox if the pricing rule type is primary.	No
Pricing Rule Type Category	Used to indicate the pricing rule type category for the pricing rule type. The valid values are: <ul style="list-style-type: none"> <li>Claim</li> <li>Aggregate Stop-Loss</li> <li>Specific Stop-Loss</li> <li>Retention Type Claim Based</li> <li>Retention Type Enrollment Based</li> </ul>	Yes

- Enter the required details in the **Main** section.
- Add the related pricing rule types in the primary pricing rule type, if required.

**Note:** **Related Pricing Rule Types** section appears only when the pricing rule type is primary.

- Define the transaction field mapping in the primary pricing rule type, if required.

**Note:** **Transaction Field Mapping** section appears only when the pricing rule type is primary.

- Associate algorithms with the pricing rule type, if required.
- Define additional data for the pricing rule type, if required.
- Add pricing items in the pricing rule type, if required.
- Add price item parameters in the pricing rule type, if required.
- Define characteristics for the pricing rule type, if required.
- Add claim templates in the claim pricing rule type, if required.
- Add the claim-specific data in the pricing rule type, if required.
- Click **Save**.

The claim pricing rule type is defined.

### **Related Topics**

For more information on...	See...
<b>Pricing Rule Type</b> screen	<a href="#">Pricing Rule Type</a> on page 2343
How to add the related pricing rule types in the primary pricing rule type	<a href="#">Adding Related Pricing Rule Types in a Primary Pricing Rule Type</a>
How to define the transaction field mapping in the primary pricing rule type	<a href="#">Defining Transaction Field Mapping in a Primary Pricing Rule Type</a>

For more information on...	See...
How to associate algorithms with the pricing rule type	<a href="#">Associating Algorithms with a Pricing Rule Type</a>
How to define additional data for the pricing rule type	<a href="#">Defining Additional Data for a Pricing Rule Type</a>
How to add pricing items in the pricing rule type	<a href="#">Adding Price Items in a Pricing Rule Type</a>
How to add price item parameters in the pricing rule type	<a href="#">Adding a Price Item Parameter in a Pricing Rule Type</a>
How to define characteristics for the pricing rule type	<a href="#">Defining Characteristics for a Pricing Rule Type</a>
How to add claim templates in the claim pricing rule type	<a href="#">Adding Claim Templates in a Claim Pricing Rule Type</a> on page 2359
How to add the claim-specific data in the pricing rule type	<a href="#">Adding the Claim-Specific Data in a Pricing Rule Type</a> on page 2360

## Adding Claim Templates in a Claim Pricing Rule Type

### Prerequisites

To add claim templates in a claim pricing rule type, you should have:

- Claim templates defined in the application

### Procedure

To add claim templates in a claim pricing rule type:

1. Ensure that the **Claim Templates** section is expanded when you are defining or editing a pricing rule type.

The **Claim Templates** section contains the following columns in a grid:

Column Name	Column Description	Mandatory (Yes or No)
Claim Template	Used to indicate the claim template.	Yes (Conditional) <b>Note:</b> This field is required when you are defining a claim template for the pricing rule type.

2. Enter the required details in the **Claim Templates** section.
3. If you want to define more than one claim template for the pricing rule type, click the **Add** (+) icon and then repeat step 2.

**Note:** However, if you want to remove a claim template from the pricing rule type, click the **Delete** (🗑️) icon corresponding to the claim template.

4. Click **Save**.

The claim templates are defined for the pricing rule type.

### Related Topics

For more information on...	See...
How to define a claim pricing rule type	<a href="#">Defining a Claim Pricing Rule Type</a> on page 2356
How to define a specific stop-loss (SSL) pricing rule type	<a href="#">Defining a Specific Stop-Loss (SSL) Pricing Rule Type</a> on page 2386

For more information on...	See...
How to define an aggregate stop-loss (ASL) pricing rule type	<a href="#">Defining a Aggregate Stop-Loss (ASL) Pricing Rule Type</a> on page 2422
How to define a retention type claim based pricing rule type	<a href="#">Defining a Retention Type Claim Based Pricing Rule Type</a> on page 2457
How to define a retention type enrollment based pricing rule type	<a href="#">Defining a Retention Type Enrollment Based Pricing Rule Type</a> on page 2486
How to edit the claim pricing rule type	<a href="#">Editing a Claim Pricing Rule Type</a> on page 2361
How to edit the specific stop-loss (SSL) pricing rule type	<a href="#">Editing a Specific Stop-Loss (SSL) Pricing Rule Type</a> on page 2391
How to edit the aggregate stop-loss (ASL) pricing rule type	<a href="#">Editing an Aggregate Stop-Loss (ASL) Pricing Rule Type</a> on page 2427
How to edit the retention type claim based pricing rule type	<a href="#">Editing a Retention Type Claim Based Pricing Rule Type</a> on page 2461
How to edit the retention type enrollment based pricing rule type	<a href="#">Editing a Retention Type Enrollment Based Pricing Rule Type</a> on page 2489

## Adding the Claim-Specific Data in a Pricing Rule Type

### Procedure



To add the Claim-Specific additional data in a pricing rule type:

1. Ensure that the **Claim-Specific Additional Data** section is expanded when you are defining or editing a pricing rule type.

The **Claim-Specific Additional Data** section contains the following fields:

Field Name	Field Description	Mandatory (Yes or No)
Rule Based Billing Eligibility Field	<p>Used to specify whether the rule based field is eligible for billing or not.</p> <p><b>Note:</b></p> <p>On clicking the <b>Search</b>  icon that appears corresponding to the <b>Rule Based Billing Eligibility Field</b> field, the <b>Field Search</b> window appears.</p> <p>On specifying the field, the description of the field appears corresponding to the <b>Rule Based Billing Eligibility Field</b> field.</p>	No



Field Name	Field Description	Mandatory (Yes or No)
Rule Based Markup or Markdown Eligibility Field	<p>Used to specify whether the rule based markup or markdown field is eligible for billing or not.</p> <p><b>Note:</b></p> <p>On clicking the <b>Search</b>  icon that appears corresponding to the <b>Rule Based Markup or Markdown Eligibility Field</b> field, the <b>Field Search</b> window appears.</p> <p>On specifying the field, the description of the field appears corresponding to the <b>Rule Based Markup or Markdown Eligibility Field</b> field.</p>	No
Markup or Markdown Billable Charge Line Type	<p>Used to specify the markup or markdown billable charge line type.</p> <p><b>Note:</b></p> <p>On clicking the <b>Search</b>  icon that appears corresponding to the <b>Markup or Markdown Billable Charge Line Type</b> field, the <b>Billable Charge Line Type Search</b> window appears.</p> <p>On specifying the billable charge line type, the description of the billable charge line type appears corresponding to the <b>Markup or Markdown Billable Charge Line Type</b> field.</p>	No

2. Enter the required details in the **Claim-Specific Additional Data** section.
3. Click **Save**.

The Claim-Specific Additional data is added in the pricing rule type.

### **Related Topics**

For more information on...	See...
How to define a claim pricing rule type	<a href="#">Defining a Claim Pricing Rule Type</a> on page 2356
How to edit the claim pricing rule type	<a href="#">Editing a Claim Pricing Rule Type</a> on page 2361

## **Editing a Claim Pricing Rule Type**

### **Prerequisites**

To edit the claim pricing rule type, you should have:

- Business Object **C1-PricingRuleClaim** defined for pricing rule.
- Pricing rule type category for claim defined in the application

### **Procedure**

To edit a claim pricing rule type:

1. Click the **Admin** link in the **Application** toolbar.

A list appears.

- From the **Admin** menu, select **P** and then click **Pricing Rule Type**.

A sub-menu appears.

- Click the **Search** option from the **Pricing Rule Type** sub-menu.

The **Pricing Rule Type** screen appears.

- In the **Pricing Rule Type List** zone, click the **Edit** (✎) icon in the **Edit** column corresponding to the pricing rule type for claim whose details you want to edit.

The **Claim Pricing Rule Type** screen appears. It contains the following sections:

- **Main** – Used to specify basic details about the claim pricing rule type.
- **Related Pricing Rule Types** – Used to define the pricing rule types which are related to the parent pricing rule type.
- **Transaction Field Mapping** – Used to specify the transaction related data mapped to the pricing rule type
- **Algorithms** – Used to define the algorithms used for the pricing rule type.
- **Additional Data** – Used to specify the additional information about the pricing rule type.
- **Price Items** – Used to define the price items assigned to the pricing rule type.
- **Price Item Parameters** – Used to define the price item parameters in the pricing rule type.
- **Characteristics** – Used to define the characteristics for the pricing rule type.
- **Claim Templates** – Used to define the pricing rule type for claim template.
- **Claim-Specific Additional Data** – Used to specify the claim specific additional data.

The **Main** section contains the following fields:

Field Name	Field Description	Mandatory (Yes or No)
Pricing Rule Type	Displays the pricing rule type.	Not applicable
Description	Used to specify the description for the pricing rule type.	Yes
Detailed Description	Used to specify additional information about the pricing rule type.	No
Related Transaction Business Object	Used to indicate the pricing rule business object. The valid values are: <ul style="list-style-type: none"> <li>• Claim Pricing Rule</li> <li>• Aggregate Stop-Loss (ASL) Pricing Rule</li> <li>• Specific Stop-Loss (SSL) Pricing Rule</li> <li>• Retention Type Claim Based Pricing Rule</li> <li>• Retention Type Enrollment Based Pricing Rule</li> </ul>	Yes
Business Object	Displays the pricing rule type business object for claim.	Not applicable
Status	Used to indicate the status of the pricing rule type. The valid values are: <ul style="list-style-type: none"> <li>• Active</li> <li>• Inactive</li> </ul>	Yes

Field Name	Field Description	Mandatory (Yes or No)
Primary	Used to select the checkbox if the pricing rule type is primary.	No
Pricing Rule Type Category	Used to indicate the pricing rule type category for the pricing rule type. The valid values are: <ul style="list-style-type: none"> <li>• Claim</li> <li>• Aggregate Stop-Loss</li> <li>• Specific Stop-Loss</li> <li>• Retention Type Claim Based</li> <li>• Retention Type Enrollment Based</li> </ul>	Yes

**Tip:** Alternatively, you can click the **Edit** button in the **Pricing Rule Type** zone to edit the pricing rule type for claim.

5. Modify the details in the **Main** section, if required.
6. Add, edit, or remove the related pricing rule types in the primary pricing rule type, if required.
7. Modify the transaction field mapping in the primary pricing rule type, if required.
8. Add, edit, or remove algorithms with the pricing rule type, if required.
9. Modify the additional data for the pricing rule type, if required.
10. Add, edit, or remove pricing items in the pricing rule type, if required.
11. Add, edit, or remove price item parameters in the pricing rule type, if required.
12. Add, edit, or remove characteristics for the pricing rule type, if required.
13. Add, edit, or remove claim templates in the claim pricing rule type, if required.
14. Modify the claim-specific data in the pricing rule type, if required.
15. Click **Save**.

The changes made to the claim pricing rule type are saved.

### **Related Topics**

For more information on...	See...
<b>Pricing Rule Type</b> screen	<a href="#">Pricing Rule Type</a> on page 2343
<b>Pricing Rule Type List</b> zone	<a href="#">Pricing Rule Type List</a> on page 2344
<b>Pricing Rule Type</b> zone	<a href="#">Pricing Rule Type</a> on page 2347
How to add the related pricing rule types in the primary pricing rule type	<a href="#">Adding Related Pricing Rule Types in a Primary Pricing Rule Type</a>
How to define the transaction field mapping in the primary pricing rule type	<a href="#">Defining Transaction Field Mapping in a Primary Pricing Rule Type</a>
How to associate algorithms with the pricing rule type	<a href="#">Associating Algorithms with a Pricing Rule Type</a>
How to define additional data for the pricing rule type	<a href="#">Defining Additional Data for a Pricing Rule Type</a>

For more information on...	See...
How to add pricing items in the pricing rule type	<a href="#">Adding Price Items in a Pricing Rule Type</a>
How to add price item parameters in the pricing rule type	<a href="#">Adding a Price Item Parameter in a Pricing Rule Type</a>
How to define characteristics for the pricing rule type	<a href="#">Defining Characteristics for a Pricing Rule Type</a>
How to add claim templates in the claim pricing rule type	<a href="#">Adding Claim Templates in a Claim Pricing Rule Type</a> on page 2359
How to add the claim-specific data in the pricing rule type	<a href="#">Adding the Claim-Specific Data in a Pricing Rule Type</a> on page 2360

## Deleting a Claim Pricing Rule Type

### Procedure

To delete a claim pricing rule type:

1. Click the **Admin** link in the **Application** toolbar.  
A list appears.
2. From the **Admin** menu, select **P** and then click **Pricing Rule Type**.  
A sub-menu appears.
3. Click the **Search** option from the **Pricing Rule Type** sub-menu.  
The **Pricing Rule Type** screen appears.

4. In the **Pricing Rule Type List** zone, click the **Delete** (🗑️) icon in the **Delete** column corresponding to the claim pricing rule type that you want to delete.

A message appears confirming whether you want to delete the claim pricing rule type.

**Note:** You can delete a claim pricing rule type only when it is not yet used in the system.

**Tip:** Alternatively, you can delete a claim pricing rule type by clicking the **Delete** button in the **Pricing Rule Type** zone.

5. Click **OK**.  
The claim pricing rule type is deleted.

### Related Topics

For more information on...	See...
<b>Pricing Rule Type</b> screen	<a href="#">Pricing Rule Type</a> on page 2343
<b>Pricing Rule Type List</b> zone	<a href="#">Pricing Rule Type List</a> on page 2344
<b>Pricing Rule Type</b> zone	<a href="#">Pricing Rule Type</a> on page 2347

## Viewing the Claim Pricing Rule Type Details

### Procedure

To view the details of a claim pricing rule type:

1. Click the **Admin** link in the **Application** toolbar.  
A list appears.
2. From the **Admin** menu, select **P** and then click **Pricing Rule Type**.  
A sub-menu appears.
3. Click the **Search** option from the **Pricing Rule Type** sub-menu.  
The **Pricing Rule Type** screen appears.
4. In the **Pricing Rule Type List** zone, click the **Broadcast**  icon corresponding to the claim pricing rule type whose details you want to view.  
The **Pricing Rule Type** zone appears.
5. View the details of the claim pricing rule type in the **Pricing Rule Type** zone.

### Related Topics

For more information on...	See...
<b>Pricing Rule Type</b> screen	<a href="#">Pricing Rule Type</a> on page 2343
<b>Pricing Rule Type List</b> zone	<a href="#">Pricing Rule Type List</a> on page 2344
<b>Pricing Rule Type</b> zone	<a href="#">Pricing Rule Type</a> on page 2347

## Defining a Claim Pricing Rule for a Parent Customer

### Prerequisites

To define a claim pricing rule for a parent customer, you should have:

- Business Object **C1-PricingRule** defined for pricing rule.
- Business Object **C1-PricingRuleClaim** defined for claim pricing rule.
- Pricing rule type defined in the application.
- Price item defined in the application.
- Rate option defined in the application.
- Claim template defined in the application.

### Procedure

To define a claim pricing rule for a parent customer:

1. Search for the account, person, or policy whose pricing details you want to view in the **Customer 360° View** screen.
2. In the **Search Results** section, click the **View**  icon corresponding to the account, person, or policy whose pricing details you want to view.  
The **Account, Person, or Policy** tab in the **Customer 360° Information** screen appears.
3. Click the **Pricing** tab and then click the **Add** link in the upper right corner of the **Parent Customer Pricing Rules** zone.

The **Pricing Rule** screen appears. It contains the following fields:

Field Name	Field Description	Mandatory (Yes or No)
Person Name	Displays the person name.	Not applicable

Field Name	Field Description	Mandatory (Yes or No)
Person Type	Displays the person type.	Not applicable
Pricing Rule Type	Used to indicate the pricing rule type to create the pricing rule.  <b>Note:</b> You can create a claim pricing rule using the <b>Pricing Rule Type</b> for claim.	Yes

4. Click **OK**.

The **Claim Pricing Rule** screen appears. It contains the following sections:

- **Customer Information** – Displays the customer information.
- **Main** – Used to specify basic details about the claim pricing rule.
- **Markup or Markdown Values** – Used to define the markup or markdown values for billable charge lines.
- **Line Items** – Used to associate line items eligible for billing.
- **Characteristics** – Used to define the characteristics for the claim pricing rule.

The **Customer Information** section contains the following fields:

Field Name	Field Description	Mandatory (Yes or No)
Parent Customer Information	Displays the parent customer information	Not applicable
Pricing Rule Type	Indicates the pricing rule type.	Not applicable

The **Main** section contains the following fields:

Field Name	Field Description	Mandatory (Yes or No)
Price Item	Used to indicate the price item.	Yes
Pricing Start Date	Used to specify the pricing rule start date.  <b>Note:</b> This field is enabled when an option from <b>Price Item</b> field is selected. By default it displays the <b>Policy Start Date</b> .	Yes
Pricing End Date	Used to specify the pricing rule end date.  <b>Note:</b> This field is enabled when an option from <b>Price Item</b> field is selected. By default it displays the <b>Policy End Date</b> .	Yes
Rate Option	Used to indicate the rate option to define the claim pricing rule for the price item.	Yes

Field Name	Field Description	Mandatory (Yes or No)
Claim Template	Used to indicate the claim template to define the claim pricing rule for a parent customer.  <b>Note:</b> This field is enabled for selection when an option from <b>Price Item</b> field is selected.	Yes

5. Enter the required details in the **Main** section.
6. Define markup or markdown values in a claim pricing rule, if required.

**Note:** The **Markup or Markdown Values** section appears only when an option from **Claim Template** field is selected.

7. Define line items in a claim pricing rule, if required.

**Note:** The **Line Items** section appears only when an option from **Claim Template** field is selected.

8. Define characteristics for a claim pricing rule, if required.
9. Click **Save**.

The claim pricing rule for a parent customer is defined.

#### **Related Topics**

For more information on...	See...
<b>Customer 360° Information – Pricing</b> tab	<a href="#">Customer 360° Information - Pricing</a> on page 229
<b>Parent Customer Pricing Rules</b> zone	<a href="#">Parent Customer Pricing Rules</a> on page 231
How to define markup or markdown values for line items in a claim pricing rule	<a href="#">Defining the Markup or Markdown Values for Line Items in a Claim Pricing Rule</a> on page 2367
How to define characteristics for a claim pricing rule	<a href="#">Defining Characteristics for a Claim Pricing Rule</a> on page 2371

## **Defining the Markup or Markdown Values for Line Items in a Claim Pricing Rule**

### **Procedure**

To define the markup or markdown values for line items in a claim pricing rule:

1. Ensure that the **Markup or Markdown Values** and **Line Items** sections are expanded only when you have selected an option from the **Claim Template** field of **Main** section while defining a claim pricing rule.

The **Markup or Markdown Values** section contains the following fields:

Field Name	Field Description	Mandatory (Yes or No)
Pricing Strategy	Used to indicate the pricing strategy. The valid values are: <ul style="list-style-type: none"> <li>• Markdown</li> <li>• Markup</li> <li>• None</li> </ul> <p><b>Note:</b> This field is disabled only when the <b>Post Run Out Claims</b> option is selected from the <b>Claim Template</b> field of <b>Main</b> section.</p>	No
Markup or Markdown Type	Used to indicate the markup or markdown value type for claim pricing rule. The valid values are: <ul style="list-style-type: none"> <li>• Flat Amount</li> <li>• Percentage</li> </ul> <p><b>Note:</b> This field is disabled only when the <b>Post Run Out Claims</b> option is selected from the <b>Claim Template</b> field of <b>Main</b> section.</p>	No
Markup or Markdown Amount	Used to specify the markup or markdown amount. <p><b>Note:</b> This field is disabled when you select,</p> <ul style="list-style-type: none"> <li>• the <b>Post Run Out Claims</b> option from the <b>Claim Template</b> field of the <b>Main</b> section.</li> <li>• or the <b>Flat Amount</b> option from the <b>Markup or Markdown Type</b> field.</li> </ul>	Yes (Conditional) <p><b>Note:</b> This field is required when you selecting <b>Percentage</b> option from the <b>Markup or Markdown Type</b> field.</p>

The **Line Items** section contains the following fields:

Field Name	Field Description	Mandatory (Yes or No)
Sequence	Displays the sequence number for the line items.	Not applicable
Line Item	Displays the billing line items.	Not applicable
Billing Eligibility	Displays whether the line item is user defined, eligible or not eligible for billing. The valid values are: <ul style="list-style-type: none"> <li>• Eligible</li> <li>• Not Eligible</li> <li>• User Defined (Default Yes)</li> <li>• User Defined (Default No)</li> </ul>	Not applicable



Field Name	Field Description	Mandatory (Yes or No)
User Defined Billing Option	Used to specify whether the billing option is user defined, eligible or not eligible.  <b>Note:</b> The checkbox for this field is by default checked and disabled for values <b>Eligible</b> or <b>Not Eligible</b> in the <b>Billing Eligibility</b> field. The checkbox for this field is enabled for values <b>User Defined (Default Yes)</b> or <b>User Defined (Default No)</b> in the <b>Billing Eligibility</b> .	Yes
Markup or Markdown Percentage Eligibility	Displays whether the line item is eligible or not eligible for markup or markdown percentage. The valid values are: <ul style="list-style-type: none"> <li>• Eligible</li> <li>• Not Eligible</li> </ul>	Not applicable
Markup or Markdown Percentage	Used to specify the percentage for markup or markdown value.  <b>Note:</b> This field is enabled only when the <b>Markup or Markdown Percentage Eligibility</b> is <b>Eligible</b> and when the <b>Markup or Markdown Type</b> is <b>Percentage</b> .	Yes

2. Enter the required details in the **Markup or Markdown Values** section.
3. Enter the required details in the **Line Items** section.
4. Click **Save**.

The markup or markdown values for line items are defined for the claim pricing rule.

#### Related Topics

For more information on...	See...
How to define a claim pricing rule for a parent customer	<a href="#">Defining a Claim Pricing Rule for a Parent Customer</a> on page 2365
How to edit the claim pricing rule for a parent customer	<a href="#">Editing a Claim Pricing Rule of a Parent Customer</a> on page 2372

## Defining the Markup or Markdown Values for Line Items for Each Rule in a Claim Pricing Rule

### Procedure

To define the markup or markdown values for line items for each rule in a claim pricing rule:

1. Ensure that sections for each rule are expanded only when you have selected an option from the **Claim Template** field of **Main** section while defining a claim pricing rule.
2. Expand the **Markup or Markdown Values** and **Line Items** sections relevant to each rule.

The **Markup or Markdown Values** section contains the following fields:

Field Name	Field Description	Mandatory (Yes or No)
Pricing Strategy	Used to indicate the pricing strategy. The valid values are: <ul style="list-style-type: none"> <li>• Markdown</li> <li>• Markup</li> <li>• None</li> </ul>	No
Markup or Markdown Type	Used to indicate the markup or markdown value type for claim pricing rule. The valid values are: <ul style="list-style-type: none"> <li>• Flat Amount</li> <li>• Percentage</li> </ul>	No
Markup or Markdown Amount	Used to specify the markup or markdown amount.  <div style="border: 1px solid black; padding: 2px;"> <b>Note:</b> This field is disabled when you select the <b>Flat Amount</b> option from the <b>Markup or Markdown Type</b> field. </div>	Yes (Conditional)  <div style="border: 1px solid black; padding: 2px;"> <b>Note:</b> This field is required when you selecting <b>Percentage</b> option from the <b>Markup or Markdown Type</b> field. </div>

The **Line Items** section contains the following fields:

Field Name	Field Description	Mandatory (Yes or No)
Sequence	Displays the sequence number for the line items.	Not applicable
Line Item	Displays the billing line items.	Not applicable
Billing Eligibility	Displays whether the line item is user defined, eligible or not eligible for billing. The valid values are: <ul style="list-style-type: none"> <li>• Eligible</li> <li>• Not Eligible</li> <li>• User Defined (Default Yes)</li> <li>• User Defined (Default No)</li> </ul>	Not applicable

Field Name	Field Description	Mandatory (Yes or No)
User Defined Billing Option	Used to specify whether the billing option is user defined, eligible or not eligible.  <b>Note:</b> The checkbox for this field is by default checked and disabled for values <b>Eligible</b> , <b>Rule Based</b> , or <b>Not Eligible</b> in the <b>Billing Eligibility</b> field.  The checkbox for this field is enabled for values <b>User Defined (Default Yes)</b> or <b>User Defined (Default No)</b> in the <b>Billing Eligibility</b> .	Yes
Markup or Markdown Percentage Eligibility	Displays whether the line item is eligible or not eligible for markup or markdown percentage. The valid values are: <ul style="list-style-type: none"> <li>• Eligible</li> <li>• Not Eligible</li> </ul>	Not applicable
Markup or Markdown Percentage	Used to specify the percentage for markup or markdown value.  <b>Note:</b> This field is enabled only when the <b>Markup or Markdown Percentage Eligibility</b> is <b>Eligible</b> and when the <b>Markup or Markdown Type</b> is <b>Percentage</b> .	Yes

3. Enter the required details in the **Markup or Markdown Values** section.
4. Enter the required details in the **Line Items** section.
5. Click **Save**.

The markup or markdown values for line items for each rule are defined for the claim pricing rule.

### **Related Topics**

For more information on...	See...
How to define a claim pricing rule for a bill group using a pricing group	<a href="#">Defining a Claim Pricing Rule for a Bill Group Using a Pricing Group</a> on page 2378
How to edit the claim pricing rule of a bill group	<a href="#">Editing a Claim Pricing Rule of a Bill Group</a> on page 2381

## **Defining Characteristics for a Claim Pricing Rule**

### **Prerequisites**

To define characteristics for a claim pricing rule, you should have:

- Characteristic types defined in the application (where the characteristic entity is set to **Pricing Rule**)

### **Procedure**

To define characteristics for a claim pricing rule:

1. Ensure that the **Characteristics** section is expanded when you are defining or editing a pricing rule.

The **Characteristics** section contains the following columns in a grid:

Column Name	Column Description	Mandatory (Yes or No)
Effective Date	Used to specify the date from when the characteristic is effective for the claim pricing rule.	Yes (Conditional) <b>Note:</b> This field is required when you are defining a characteristic for the claim pricing rule.
Characteristic Type	Used to indicate the characteristic type. <b>Note:</b> The list includes only those characteristic types where the characteristic entity is set to <b>Pricing Rule</b> .	Yes (Conditional) <b>Note:</b> This field is required when you are defining a characteristic for the claim pricing rule.
Characteristic Value	Used to specify the value for the characteristic type. <b>Note:</b> If you select a predefined characteristic type, the <b>Search</b>  icon appears corresponding to the <b>Characteristic Value</b> field. On clicking the <b>Search</b> icon, the <b>Predefined Characteristic Search</b> window appears. On specifying the value for a predefined characteristic type, the description of the characteristic value appears corresponding to the <b>Characteristic Value</b> field.	Yes (Conditional) <b>Note:</b> This field is required when you are defining a characteristic for the claim pricing rule.

- Enter the required details in the **Characteristics** section.
- If you want to define more than one characteristic for the claim pricing rule, click the **Add**  icon and then repeat step 2.

**Note:** However, if you want to remove a characteristic from the claim pricing rule, click the **Delete**  icon corresponding to the characteristic.

- Click **Save**.

The characteristics are defined for the claim pricing rule.

### **Related Topics**

For more information on...	See...
How to define a claim pricing rule for a parent customer	<a href="#">Defining a Claim Pricing Rule for a Parent Customer</a> on page 2365
How to edit the claim pricing rule for a parent customer	<a href="#">Editing a Claim Pricing Rule of a Parent Customer</a> on page 2372

## **Editing a Claim Pricing Rule of a Parent Customer**



### **Prerequisites**

To edit a claim pricing rule of a parent customer, you should have:

- Business Object **C1-PricingRuleClaim** defined for claim pricing rule.
- Claim template defined in the application.

### Procedure

To edit a claim pricing rule of a parent customer:

1. Search for the account, person, or policy whose pricing details you want to view in the **Customer 360° View** screen.
2. In the **Search Results** section, click the **View** () icon corresponding to the account, person, or policy whose pricing details you want to view.  
The **Account, Person, or Policy** tab in the **Customer 360° Information** screen appears.
3. Click the **Pricing** tab, in the **Parent Customer Pricing Rules** zone click the **Edit** () icon in the **Edit** column corresponding to the pricing rule type for claim whose claim pricing rule details you want to edit.

The **Claim Pricing Rule** screen appears. It contains the following sections:

- **Customer Information** – Displays the customer information.
- **Main** – Used to specify basic details about the claim pricing rule.
- **Markup or Markdown Values** – Used to define the markup or markdown values for billable charge lines.
- **Line Items** – Used to associate line items eligible for billing.
- **Characteristics** – Used to define the characteristics for the claim pricing rule.

The **Customer Information** section contains the following fields:

Field Name	Field Description	Mandatory (Yes or No)
Parent Customer Information	Displays the parent customer information	Not applicable
Pricing Rule Type	Indicates the pricing rule type.	Not applicable

The **Main** section contains the following fields:

Field Name	Field Description	Mandatory (Yes or No)
Price Item	Indicates the price item.	Not applicable
Pricing Start Date	Displays the pricing rule start date.	Not applicable
Pricing End Date	Used to specify the pricing rule end date. <b>Note:</b> This field by default displays the <b>Policy End Date</b> .	Yes
Rate Option	Indicates the rate option to edit the claim pricing rule for the price item.	Yes
Claim Template	Indicates the claim template of the claim pricing rule for a parent customer. <b>Note:</b> This field is enabled only when you click the <b>Reapply Claim Template</b> button.	Yes (Conditional) <b>Note:</b> This field is required when you are reapplying for a claim template.

**Note:** This section also consists of a button, **Reapply Claim Template**, on clicking the button a message occurs indicating that updating the claim template will reset all the default fields on the pricing rule.

4. Modify the details in the **Main** section, if required.
5. Modify the markup or markdown values in a claim pricing rule, if required.
6. Modify the line items in a claim pricing rule, if required.
7. Add, edit, or remove characteristics for a claim pricing rule, if required.
8. Click **Save**.

The changes made to a claim pricing rule for a parent customer are saved.

### **Related Topics**

<b>For more information on...</b>	<b>See...</b>
<b>Customer 360° Information – Pricing</b> tab	<a href="#">Customer 360° Information - Pricing</a> on page 229
<b>Parent Customer Pricing Rules</b> zone	<a href="#">Parent Customer Pricing Rules</a> on page 231
How to define markup or markdown values for line items in a claim pricing rule	<a href="#">Defining the Markup or Markdown Values for Line Items in a Claim Pricing Rule</a> on page 2367
How to define characteristics for a claim pricing rule	<a href="#">Defining Characteristics for a Claim Pricing Rule</a> on page 2371

## **Viewing a Claim Pricing Rule of a Parent Customer**

### **Procedure**

To view a claim pricing rule of a parent customer:

1. Search for a parent customer whose pricing details you want to view in the **Customer 360° View** screen.
2. In the **Search Results** section, click the **View** () icon corresponding to the account, person, or policy whose pricing details you want to view.

The **Person** tab appears in the **Customer 360° Information** screen

3. Click the **Pricing** tab.

The **Pricing** tab appears.

4. In the **Parent Customer Pricing Rules** zone, click the link in the **Pricing Rule Information** column corresponding to the claim pricing rule type whose claim pricing rule parent customer details you want to view.

The **Claim** screen appears. It contains the following zone:

- **Claim** – Displays the pricing rule claim details for a parent customer. It contains the following sections:
  - **Main** – Displays the basic details about the claim pricing rule.
  - **Markup or Markdown Values** – Displays the markup or markdown values for billable charge lines.
  - **Line Items** – Displays the associated line items eligible for billing.
  - **Characteristics** – Displays the characteristics defined for the claim pricing rule.



5. View the basic details of claim pricing rule in the **Main** zone.
6. View the markup or markdown values for billable charge lines in the **Markup or Markdown Values** zone.
7. View the associated line items eligible for billing in the **Line Items** zone.
8. View the characteristics defined for the claim pricing rule in the **Characteristics** zone.

**Related Topics**

For more information on...	See...
<b>Customer 360° Information – Pricing</b> tab	<a href="#">Customer 360° Information - Pricing</a> on page 229
<b>Parent Customer Pricing Rules</b> zone	<a href="#">Parent Customer Pricing Rules</a> on page 231
<b>Pricing Rule</b> screen	<a href="#">Pricing Rule (Used for Viewing)</a> on page 2688
<b>Claim</b> zone	<a href="#">Claim</a> on page 2689

**Deleting a Claim Pricing Rule of a Parent Customer****Procedure**

To delete a claim pricing rule of a parent customer:

1. Search for the account, person, or policy whose pricing details you want to view in the **Customer 360° View** screen.
2. In the **Search Results** section, click the **View** () icon corresponding to the account, person, or policy whose pricing details you want to view. The **Account, Person, or Policy** tab in the **Customer 360° Information** screen appears.
3. Click the **Pricing** tab, in the **Parent Customer Pricing Rules** zone, click the **Delete** () icon in the **Delete** column corresponding to the claim pricing rule type whose claim pricing rule you want to delete. A message appears confirming whether you want to delete the claim pricing rule.
4. Click **OK**.  
The claim pricing rule is deleted.

**Related Topics**

For more information on...	See...
<b>Customer 360° Information – Pricing</b> tab	<a href="#">Customer 360° Information - Pricing</a> on page 229
<b>Parent Customer Pricing Rules</b> zone	<a href="#">Parent Customer Pricing Rules</a> on page 231

**Defining a Claim Pricing Rule for a Bill Group****Prerequisites**

To define a claim pricing rule for a bill group, you should have:

- Business Object **C1-PricingRule** defined for pricing rule.
- Business Object **C1-PricingRuleClaim** defined for claim pricing rule.
- Pricing rule type defined in the application.
- Policy status defined in the application.
- Price item defined in the application.
- Rate option defined in the application.
- Claim template defined in the application.

**Procedure**

To define a claim pricing rule for a bill group:

1. Search for the account, person, or policy whose pricing details you want to view in the **Customer 360° View** screen.
2. In the **Search Results** section, click the **View** () icon corresponding to the account, person, or policy whose pricing details you want to view. The **Account, Person, or Policy** tab in the **Customer 360° Information** screen appears.
3. Click the **Pricing** tab and then click the **Add** link in the upper right corner of the **Bill Group ASO Policy Pricing Rules** zone.

The **Pricing Rule** screen appears. It contains the following fields:

Field Name	Field Description	Mandatory (Yes or No)
Person Name	Displays the person name.	Not applicable
Person Type	Displays the person type.	Not applicable
Pricing Rule Type	Used to indicate the pricing rule type to create the pricing rule.  <b>Note:</b> You can create a claim pricing rule using the <b>Pricing Rule Type</b> for claim.	Yes
Pricing Group	Used to indicate the pricing group.	No
Policy Status	Used to indicate the policy status for pricing rule. The valid values are: <ul style="list-style-type: none"> <li>• In Force/Active</li> <li>• Post Runout</li> <li>• Runout</li> </ul> <b>Note:</b> Claim pricing rule cannot be created for <b>Runout</b> or <b>Post Runout</b> policy status where the policy run out End Date is missing.	Yes

4. Click **OK**.

The **Claim Pricing Rule** screen appears. It contains the following sections:

- **Customer Information** – Displays the customer information for bill group.
- **Main** – Used to specify basic details about the claim pricing rule.
- **Markup or Markdown Values** – Used to define the markup or markdown values for billable charge lines.
- **Line Items** – Used to associate line items eligible for billing.
- **Characteristics** – Used to define the characteristics for the claim pricing rule.

The **Customer Information** section contains the following fields:

Field Name	Field Description	Mandatory (Yes or No)
Bill Group Information	Displays the bill group information.	Not applicable
Policy Start Date	Displays the policy start date.	Not applicable
Policy End Date	Displays the policy end date.	Not applicable



Field Name	Field Description	Mandatory (Yes or No)
Policy Status	Indicates the policy status for pricing rule. The valid values are: <ul style="list-style-type: none"> <li>In Force/Active</li> <li>Post Runout</li> <li>Runout</li> </ul>	Not applicable
Pricing Rule Type	Indicates the pricing rule type.	Not applicable

The **Main** section contains the following fields:

Field Name	Field Description	Mandatory (Yes or No)
Price Item	Used to indicate the price item.	Yes
Pricing Start Date	Used to specify the pricing rule start date.  <div style="border: 1px solid black; padding: 5px;"> <b>Note:</b>  This field is enabled when an option from <b>Price Item</b> field is selected.  By default it displays the <b>Policy Start Date</b>. </div>	Yes
Pricing End Date	Used to specify the pricing rule end date.  <div style="border: 1px solid black; padding: 5px;"> <b>Note:</b>  This field is enabled when an option from <b>Price Item</b> field is selected.  By default it displays the <b>Policy End Date</b>. </div>	Yes
Rate Option	Used to indicate the rate option to define the claim pricing rule for the price item.	Yes
Claim Template	Used to indicate the claim template to define the claim pricing rule for a bill group.  <div style="border: 1px solid black; padding: 5px;"> <b>Note:</b> This field is enabled for selection when an option from <b>Price Item</b> field is selected. </div>	Yes

5. Enter the required details in the **Main** section.
6. Define markup or markdown values in a claim pricing rule, if required.

**Note:** The **Markup or Markdown Values** section appears only when an option from **Claim Template** field is selected.

7. Define line items in a claim pricing rule, if required.

**Note:** The **Line Items** section appears only when an option from **Claim Template** field is selected.

8. Define characteristics for a claim pricing rule, if required.
9. Click **Save**.

The claim pricing rule for a bill group is defined.

**Note:** A price list and price assignment is created, the price list created is assigned to the claim pricing rule.

### **Related Topics**

<b>For more information on...</b>	<b>See...</b>
<b>Customer 360° Information – Pricing</b> tab	<i>Customer 360° Information - Pricing</i> on page 229
<b>Bill Group ASO Policy Pricing Rules</b> zone	<i>Bill Group ASO Policy Pricing Rules</i> on page 237
How to define markup or markdown values for line items in a claim pricing rule	<i>Defining the Markup or Markdown Values for Line Items in a Claim Pricing Rule</i> on page 2367
How to define characteristics for a claim pricing rule	<i>Defining Characteristics for a Claim Pricing Rule</i> on page 2371

## **Defining a Claim Pricing Rule for a Bill Group Using a Pricing Group**

### **Prerequisites**

To define a claim pricing rule for a bill group using a pricing group, you should have:

- Business Object **C1-PricingRule** defined for pricing rule.
- Business Object **C1-PricingRuleClaim** defined for claim pricing rule.
- Pricing rule type defined in the application.
- Pricing group defined in the application.
- Policy status defined in the application.
- Price item defined in the application.
- Rate option defined in the application.
- Claim template defined in the application.

### **Procedure**

To define a claim pricing rule for a bill group using a pricing group:

1. Search for the account, person, or policy whose pricing details you want to view in the **Customer 360° View** screen.
2. In the **Search Results** section, click the **View** () icon corresponding to the account, person, or policy whose pricing details you want to view. The **Account**, **Person**, or **Policy** tab in the **Customer 360° Information** screen appears.
3. Click the **Pricing** tab and then click the **Add** link in the upper right corner of the **Bill Group ASO Policy Pricing Rules** zone.

The **Pricing Rule** screen appears. It contains the following fields:

<b>Field Name</b>	<b>Field Description</b>	<b>Mandatory (Yes or No)</b>
Person Name	Displays the person name.	Not applicable
Person Type	Displays the person type.	Not applicable

Field Name	Field Description	Mandatory (Yes or No)
Pricing Rule Type	Used to indicate the pricing rule type to create the pricing rule.  <b>Note:</b> You can create a claim pricing rule using the <b>Pricing Rule Type</b> for claim.	Yes
Pricing Group	Used to indicate the pricing group.	Yes
Policy Status	Used to indicate the policy status for pricing rule. The valid values are: <ul style="list-style-type: none"> <li>• In Force/Active</li> <li>• Post Runout</li> <li>• Runout</li> </ul> <b>Note:</b> Claim pricing rule cannot be created for <b>Runout</b> or <b>Post Runout</b> policy status where the policy run out End Date is missing.	Yes

#### 4. Click **OK**.

The **Claim Pricing Rule** screen appears. It contains the following sections:

- **Customer Information** – Displays the customer information for bill group using pricing group.
- **Main** – Used to specify basic details about the claim pricing rule.
- **Markup or Markdown Values** – Used to define the markup or markdown values for billable charge line for each rule.
- **Line Items** – Used to associate line items eligible for billing for each rule.
- **Characteristics** – Used to define the characteristics for the claim pricing rule.

The **Customer Information** section contains the following fields:

Field Name	Field Description	Mandatory (Yes or No)
Bill Group Information	Displays the bill group information.	Not applicable
Policy Start Date	Displays the policy start date.	Not applicable
Policy End Date	Displays the policy end date.	Not applicable
Policy Status	Indicates the policy status for pricing rule. The valid values are: <ul style="list-style-type: none"> <li>• In Force/Active</li> <li>• Post Runout</li> <li>• Runout</li> </ul>	Not applicable
Pricing Group	Displays the pricing group.	Not applicable
Pricing Rule Type	Indicates the pricing rule type.	Not applicable

The **Main** section contains the following fields:

Field Name	Field Description	Mandatory (Yes or No)
Price Item	Used to indicate the price item.	Yes
Pricing Start Date	Used to specify the pricing rule start date.  <b>Note:</b> This field is enabled when an option from <b>Price Item</b> field is selected. By default it displays the <b>Policy Start Date</b> .	Yes
Pricing End Date	Used to specify the pricing rule end date.  <b>Note:</b> This field is enabled when an option from <b>Price Item</b> field is selected. By default it displays the <b>Policy End Date</b> .	Yes
Rate Option	Used to indicate the rate option to define the claim pricing rule for the price item.	Yes
Claim Template	Used to indicate the claim template to define the claim pricing rule for a bill group.  <b>Note:</b> This field is enabled for selection when an option from <b>Price Item</b> field is selected.	Yes

5. Enter the required details in the **Main** section.
6. Define markup or markdown values for line items for each rule in a claim pricing rule, if required.

**Note:** The **Markup or Markdown Values** section appears in the rule section and the rule section appears only when an option from **Claim Template** field is selected.

7. Define line items for each rule in a claim pricing rule, if required.

**Note:** The **Line Items** section appears in the rule section and the rule section appears only when an option from **Claim Template** field is selected.

8. Define characteristics for a claim pricing rule, if required.
9. Click **Save**.

The claim pricing rule for a bill group using a pricing group is defined.

**Note:** A price list and price assignment is created, the price list created is assigned to the claim pricing rule.

### Related Topics

For more information on...	See...
<b>Customer 360° Information – Pricing</b> tab	<a href="#">Customer 360° Information - Pricing</a> on page 229
<b>Bill Group ASO Policy Pricing Rules</b> zone	<a href="#">Bill Group ASO Policy Pricing Rules</a> on page 237
How to define markup or markdown values for line items for each rule in a claim pricing rule	<a href="#">Defining the Markup or Markdown Values for Line Items for Each Rule in a Claim Pricing Rule</a> on page 2369

For more information on...	See...
How to define characteristics for a claim pricing rule	<a href="#">Defining Characteristics for a Claim Pricing Rule</a> on page 2371

## Editing a Claim Pricing Rule of a Bill Group

### Prerequisites

To edit a claim pricing rule of a bill group, you should have:

- Business Object **C1-PricingRuleClaim** defined for claim pricing rule.
- Claim template defined in the application.

### Procedure

To edit a claim pricing rule of a bill group:

1. Search for the account, person, or policy whose pricing details you want to view in the **Customer 360° View** screen.
2. In the **Search Results** section, click the **View** () icon corresponding to the account, person, or policy whose pricing details you want to view.

The **Account, Person, or Policy** tab in the **Customer 360° Information** screen appears.

3. Click the **Pricing** tab, in the **Bill Group ASO Policy Pricing Rules** zone click the **Edit** () icon in the **Edit** column corresponding to the pricing rule type for claim whose claim pricing rule details you want to edit.

The **Claim Pricing Rule** screen appears. It contains the following sections:

- **Customer Information** – Displays the customer information for bill group.
- **Main** – Used to specify basic details about the claim pricing rule.
- **Markup or Markdown Values** – Used to define the markup or markdown values for billable charge lines.
- **Line Items** – Used to associate line items eligible for billing.
- **Characteristics** – Used to define the characteristics for the claim pricing rule.

The **Customer Information** section contains the following fields:

Field Name	Field Description	Mandatory (Yes or No)
Bill Group Information	Displays the bill group information.	Not applicable
Policy Start Date	Displays the policy start date.	Not applicable
Policy End Date	Displays the policy end date.	Not applicable
Policy Status	Indicates the policy status for pricing rule. The valid values are: <ul style="list-style-type: none"> <li>• In Force/Active</li> <li>• Post Runout</li> <li>• Runout</li> </ul>	Not applicable
Pricing Rule Type	Indicates the pricing rule type.	Not applicable

The **Main** section contains the following fields:

Field Name	Field Description	Mandatory (Yes or No)
Price Item	Indicates the price item.	Not applicable
Pricing Start Date	Displays the pricing rule start date.	Not applicable
Pricing End Date	Used to specify the pricing rule end date. <b>Note:</b> This field by default displays the <b>Policy End Date</b> .	Yes
Rate Option	Indicates the rate option to edit the claim pricing rule for the price item.	Yes
Claim Template	Indicates the claim template of the claim pricing rule for a parent customer. <b>Note:</b> This field is enabled only when you click the <b>Reapply Claim Template</b> button.	Yes (Conditional) <b>Note:</b> This field is required when you are reapplying for a claim template.

**Note:** This section also consists of a button, **Reapply Claim Template**, on clicking the button a message occurs indicating that updating the claim template will reset all the default fields on the pricing rule.

- Modify the details in the **Main** section, if required.
- Modify the markup or markdown values in a claim pricing rule, if required.
- Modify the line items in a claim pricing rule, if required.
- Add, edit, or remove characteristics for the characteristics for a claim pricing rule, if required.
- Click **Save**.

The changes made to a claim pricing rule for a bill group are saved.

### **Related Topics**

For more information on...	See...
<b>Customer 360° Information – Pricing</b> tab	<a href="#">Customer 360° Information - Pricing</a> on page 229
<b>Bill Group ASO Policy Pricing Rules</b> zone	<a href="#">Bill Group ASO Policy Pricing Rules</a> on page 237
How to define markup or markdown values for line items in a claim pricing rule	<a href="#">Defining the Markup or Markdown Values for Line Items in a Claim Pricing Rule</a> on page 2367
How to define characteristics for a claim pricing rule	<a href="#">Defining Characteristics for a Claim Pricing Rule</a> on page 2371

## **Viewing a Claim Pricing Rule of a Bill Group**

### **Procedure**

To view a claim pricing rule of a bill group:

- Search for a bill group in the **Customer 360° View** screen.
- In the **Search Results** section, click the **View** () icon corresponding to the account, person, or policy whose pricing details you want to view.

The **Person** tab appears in the **Customer 360° Information** screen.

- Click the **Pricing** tab.

The **Pricing** tab appears.

4. In the **Bill Group ASO Policy Information** zone, click the **Broadcast** () icon corresponding to the bill group whose claim pricing rule bill group details you want to view.
5. In the **Bill Group ASO Policy Pricing Rules** zone, click the link in the **Pricing Rule Information** column corresponding to the claim pricing rule type whose claim pricing rule bill group you want to view. The **Pricing Rule** screen appears. It contains the following zone:
  - **Claim** – Displays the pricing rule claim details for a bill group. It contains the following sections:
    - **Main** – Displays the basic details about the claim pricing rule.
    - **Markup or Markdown Values** – Displays the markup or markdown values for billable charge lines.
    - **Line Items** – Displays the associated line items eligible for billing.
    - **Characteristics** – Displays the characteristics defined for the claim pricing rule.
6. View the basic details of claim pricing rule in the **Main** section.
7. View the markup or markdown values for billable charge lines in the **Markup or Markdown Values** section.
8. View the associated line items eligible for billing in the **Line Items** section.
9. View the characteristics defined for the claim pricing rule in the **Characteristics** section.



#### **Related Topics**

<b>For more information on...</b>	<b>See...</b>
<b>Customer 360° Information – Pricing</b> tab	<a href="#">Customer 360° Information - Pricing</a> on page 229
<b>Bill Group ASO Policy Pricing Rules</b> zone	<a href="#">Bill Group ASO Policy Pricing Rules</a> on page 237
<b>Pricing Rule</b> screen	<a href="#">Pricing Rule (Used for Viewing)</a> on page 2688
<b>Claim</b> zone	<a href="#">Claim</a> on page 2689

## **Deleting a Claim Pricing Rule of a Bill Group**

### **Procedure**

To delete a claim pricing rule of a bill group:

1. Search for the account, person, or policy whose pricing details you want to view in the **Customer 360° View** screen.
2. In the **Search Results** section, click the **View** () icon corresponding to the account, person, or policy whose pricing details you want to view. The **Account**, **Person**, or **Policy** tab in the **Customer 360° Information** screen appears.
3. Click the **Pricing** tab, in the **Bill Group ASO Policy Pricing Rules** zone, click the **Delete** () icon in the **Delete** column corresponding to the pricing rule type that you want to delete. A message appears confirming whether you want to delete the claim pricing rule.
4. Click **OK**. The claim pricing rule is deleted.

### **Related Topics**

For more information on...	See...
<b>Customer 360° Information – Pricing</b> tab	<a href="#">Customer 360° Information - Pricing</a> on page 229
<b>Bill Group ASO Policy Pricing Rules</b> zone	<a href="#">Bill Group ASO Policy Pricing Rules</a> on page 237

## Specific Stop-Loss (SSL) Pricing

Stop-Loss coverage provides liability limits on claims for individuals and for the employer group as a whole. Specific Stop-Loss (SSL) is the form of excess risk coverage that provides protection for the employer against a high claim on any one individual. This is protection against abnormal severity of a single member claim rather than abnormal frequency of claims in total. Specific stop-loss is also known as individual stop-loss. The specific stop-loss is calculated on the claim transactions received for an individual.

You can define a specific stop-loss pricing rule at the parent customer and bill group levels. The specific stop-loss pricing rule at the bill group level takes precedence over the specific stop-loss pricing rule at the parent customer level. You can define specific stop-loss pricing rules for parent customers and bill groups from the **Customer 360° Information** screen. You can define a specific stop-loss pricing rule using a specific stop-loss pricing rule type.

It is the specific stop-loss pricing rule type which helps the system to determine:

- Business object using which the specific stop-loss pricing rule should be created in the system.

**Note:** The specific stop-loss pricing rule type is not a primary pricing rule type. It inherits the attributes from a claim pricing rule type where it is included as a related pricing rule type.

- Algorithm which should be triggered while validating a transaction.

**Note:** An algorithm type for validating a transaction is not shipped from the product. You need to create a custom algorithm type, if required.

- Algorithms which should be triggered while deriving account and price item for a transaction.

**Note:** You must create an algorithm using the **C1\_ACCPRISL** algorithm type and attach it to the **Account and Price Item Derivation** system event.

- Post-processing algorithm which should be triggered once the specific stop-loss pricing rule is derived.

**Note:** A post-processing algorithm type is not shipped from the product. You need to create a custom algorithm type, if required.

- Price items for which you can define specific stop-loss pricing rules using the specific stop-loss pricing rule type.
- Rate options that you can use while defining the pricing for a price item.
- Different type of account to which the price item should be billed based on the specified priority.

**Note:** Ideally, the price item parameters should not be specified in a specific stop-loss pricing rule type. The price item parameters which are specified in the claim pricing rule type are used for accumulating specific stop-loss.

- Additional information, such as:
  - Identifier which helps to determine whether the specific stop-loss should be calculated for claim transactions which are received during the run-in period of the policy.
  - SSL billable charge line type using which you want to create specific stop-loss billable charges.
  - Domestic provider claim billable charge line type using which you want to create domestic provider claim calculation lines.



- Markup or markdown billable charge line type using which you want to create markup or markdown calculation lines.
- Transaction field which you want to use in the rules as the output parameter to determine whether the line item is eligible for billing.
- Transaction field which you want to use in the rules as the output parameter to determine whether the markup or markdown calculation line is eligible for billing.
- Transaction field which you want to use in the rules as the output parameter to determine whether the domestic provider claim calculation line is eligible for billing.

Once a specific stop-loss pricing rule type is defined, you can create specific stop-loss pricing rules using the specific stop-loss pricing rule type. While defining a specific stop-loss pricing rule for a parent customer, you need to specify the following:

- Price item for which you want to define the pricing.
- Pricing date range during which the pricing is effective.
- Rate option which you want to use while defining the specific stop-loss pricing.
- Whether the specific stop-loss pricing rule must be used for only pricing or for pricing and billing.
- Whether the specific stop-loss must be accumulated at the member or main subscriber level.
- Settlement frequency which helps to determine the bill after date. The valid values are:
  - Immediately – If you select this option from the list, the bill after date is not calculated. The specific stop-loss billable charge is billed immediately in the next bill cycle.
  - Manually (At Required Intervals) - If you select this option from the list, the bill after date which is specified in the **Manual Settlement Bill After Date** parameter while executing the **C1-BCSSL** batch is stamped on the specific stop-loss billable charge.
  - Never - If you select this option from the list, the bill after date which is specified in the **Manual Settlement Bill After Date** parameter while executing the **C1-BCSSL** batch is stamped on the specific stop-loss billable charge.
  - Yearly – If you select this option from the list, the bill after date in the specific stop-loss billable charge is set to the pricing end date.
- Accumulation parameters (such as incurred start date, incurred end date, paid start date, paid end date, etc.) based on which you want to accumulate the specific stop-loss for the claim transactions which are processed in the run-in or active period of the policy.
- The maximum limit defined for specific stop-loss at the member or main subscriber level.
- Settlement days which helps to calculate the settlement date (i.e. pricing end date, incurred end date, or paid end date whichever is later + settlement days)
- Whether the Aggregate Specific Stop-Loss (ASSL) should be calculated during the C1-BCSSL batch run for each bill group
- The ASSL limit indicating that the aggregate specific stop-loss amount beyond this limit will be paid by the insurance company to the ASSL credit account.
- Whether any member, main subscriber, or provider is excluded during the specific stop-loss calculation Different SSL limit (i.e. laseded amount) for a member, main subscriber, or provider who are expected to have higher claim amount.

However, while defining a specific stop-loss pricing rule for a bill group, you need to specify the following:

- The status of the policy for which you want to define the specific stop-loss pricing rule.
- Price item for which you want to define the pricing.

- Parent customer's SSL pricing rule from which you want to inherit the accumulation parameters and exclusion and lasing information.

**Note:** The pricing date range is derived from the parent customer's specific stop-loss pricing rule because the specific stop-loss pricing rules for parent customer and bill group should have the same date range.

- Rate option which you want to use while defining the specific stop-loss pricing.
- Whether the specific stop-loss calculated for the claim transactions which are mapped to the specified price items and price item parameters should be accumulated.
- The SSL limit indicating that the specific stop-loss amount beyond this limit will be paid by the insurance company.
- The maximum specific stop-loss limit defined for the member when the claim transactions are received in the run-in period of the policy.
- Whether line items in a claim pricing rule are eligible for specific stop-loss

**Note:** By default, the line items where the pricing rule type category is set to Specific Stop-Loss appear in the Line Items section. If you want to set specific stop-loss eligibility for the line items which belong to a particular claim pricing rule, you must select the respective claim pricing rule.

- Whether certain percentage of SSL should be excluded while calculating specific stop-loss for domestic provider claim.

You can also specify a pricing group while defining a specific stop-loss pricing rule for a bill group. If you specify a pricing group while defining a stop-loss pricing rule for a bill group, you will have to define the following details for each rule defined in the pricing group:

- Whether the specific stop-loss calculated for the claim transactions which are mapped to the specified price items and price item parameters should be accumulated.
- The SSL limit indicating that the specific stop-loss amount beyond this limit will be paid by the insurance company.
- The maximum specific stop-loss limit defined for the member when the claim transactions are received in the run-in period of the policy.
- Whether line items in a claim pricing rule are eligible for specific stop-loss.

**Note:** By default, the line items where the pricing rule type category is set to Specific Stop-Loss appear in the Line Items section. If you want to set specific stop-loss eligibility for the line items which belong to a particular claim pricing rule, you must select the respective claim pricing rule.

- Whether certain percentage of SSL should be excluded while calculating specific stop-loss for domestic provider claim.

Once a specific stop-loss pricing rule is defined for a parent customer and bill group, the system creates one price assignment, one price list, and one price list assignment.

## Defining a Specific Stop-Loss (SSL) Pricing Rule Type

### Prerequisites

To define a specific stop-loss (SSL) pricing rule type, you should have:

- Business Object **C1-PricingRuleTypeSSL** defined for pricing rule type.
- Business Object **C1-PricingRuleSSL** defined for pricing rule.
- Pricing rule type category for specific stop-loss defined in the application

### Procedure

To define a specific stop-loss pricing rule type:

1. Click the **Admin** link in the **Application** toolbar.  
A list appears.
2. From the **Admin** menu, select **P** and then click **Pricing Rule Type**.  
A sub-menu appears.
3. Click the **Add** option from the **Pricing Rule Type** sub-menu.

The **Select Business Object** screen appears. It contains the following field:

Field Name	Field Description	Mandatory (Yes or No)
Pricing Rule Type Business Object	Used to indicate the business object using which you want to create the pricing rule type.  <b>Note:</b> You can create a specific stop-loss pricing rule type using the <b>Specific Stop-Loss (SSL) Pricing Rule Type</b> business object.	Yes

**Tip:** Alternatively, you can access this screen by clicking the **Add** button in the **Page Title** area of the **Pricing Rule Type** screen.

4. Select the **Specific Stop-Loss (SSL) Pricing Rule Type** business object.
5. Click **OK**.

The **Specific Stop-Loss (SSL) Pricing Rule Type** screen appears. It contains the following sections:

- **Main** – Used to specify basic details about the specific stop-loss pricing rule type.
- **Related Pricing Rule Types** – Used to define the pricing rule types which are related to the parent pricing rule type.
- **Transaction Field Mapping** – Used to specify the transaction related data mapped to the pricing rule type
- **Algorithms** – Used to define the algorithms used for the pricing rule type.
- **Additional Data** – Used to specify the additional information about the pricing rule type.
- **Price Items** – Used to define the price items assigned to the pricing rule type.
- **Price Item Parameters** – Used to define the price item parameters in the pricing rule type.
- **Characteristics** – Used to define the characteristics for the pricing rule type.
- **SSL-Specific Additional Data** – Used to specify the specific stop-loss related additional data.

The **Main** section contains the following fields:

Field Name	Field Description	Mandatory (Yes or No)
Pricing Rule Type	Used to specify the pricing rule type.	Yes
Description	Used to specify the description for the pricing rule type.	Yes
Detailed Description	Used to specify additional information about the pricing rule type.	No

Field Name	Field Description	Mandatory (Yes or No)
Related Transaction Business Object	Used to indicate the pricing rule business object. The valid values are: <ul style="list-style-type: none"> <li>Claim Pricing Rule</li> <li>Aggregate Stop-Loss (ASL) Pricing Rule</li> <li>Specific Stop-Loss (SSL) Pricing Rule</li> <li>Retention Type Claim Based Pricing Rule</li> <li>Retention Type Enrollment Based Pricing Rule</li> </ul>	Yes
Business Object	Indicate the pricing rule type business object for specific stop-loss.	Not applicable
Status	Used to indicate the status of the pricing rule type. The valid values are: <ul style="list-style-type: none"> <li>Active</li> <li>Inactive</li> </ul>	Yes
Primary	Used to select the checkbox if the pricing rule type is primary.	No
Pricing Rule Type Category	Used to indicate the pricing rule type category for the pricing rule type. The valid values are: <ul style="list-style-type: none"> <li>Claim</li> <li>Aggregate Stop-Loss</li> <li>Specific Stop-Loss</li> <li>Retention Type Claim Based</li> <li>Retention Type Enrollment Based</li> </ul>	Yes

- Enter the required details in the **Main** section.
- Add the related pricing rule types in the primary pricing rule type, if required.

**Note: Related Pricing Rule Types** section appears only when the pricing rule type is primary.

- Define the transaction field mapping in the primary pricing rule type, if required.

**Note: Transaction Field Mapping** section appears only when the pricing rule type is primary.

- Associate algorithms with the pricing rule type, if required.
- Define additional data for the pricing rule type, if required.
- Add pricing items in the pricing rule type, if required.
- Add price item parameters in the pricing rule type, if required.
- Define characteristics for the pricing rule type, if required.
- Add the SSL-Specific data in the pricing rule type, if required.
- Click **Save**.

The specific stop-loss pricing rule type is defined.

**Related Topics**

For more information on...	See...
<b>Pricing Rule Type</b> screen	<a href="#">Pricing Rule Type</a> on page 2343
How to add the related pricing rule types in the primary pricing rule type	<a href="#">Adding Related Pricing Rule Types in a Primary Pricing Rule Type</a>
How to define the transaction field mapping in the primary pricing rule type	<a href="#">Defining Transaction Field Mapping in a Primary Pricing Rule Type</a>
How to associate algorithms with the pricing rule type	<a href="#">Associating Algorithms with a Pricing Rule Type</a>
How to define additional data for the pricing rule type	<a href="#">Defining Additional Data for a Pricing Rule Type</a>
How to add pricing items in the pricing rule type	<a href="#">Adding Price Items in a Pricing Rule Type</a>
How to add price item parameters in the pricing rule type	<a href="#">Adding a Price Item Parameter in a Pricing Rule Type</a>
How to define characteristics for the pricing rule type	<a href="#">Defining Characteristics for a Pricing Rule Type</a>
How to add the SSL-Specific data in the pricing rule type	<a href="#">Adding the SSL-Specific Data in a Pricing Rule Type</a> on page 2389



**Adding the SSL-Specific Data in a Pricing Rule Type****Procedure**



To add the SSL-Specific additional data in a pricing rule type:

1. Ensure that the **SSL-Specific Additional Data** section is expanded when you are defining or editing a pricing rule type.

The **SSL-Specific Additional Data** section contains the following fields:

Field Name	Field Description	Mandatory (Yes or No)
SSL Billable Charge Line Type	Used to specify the Specific Stop-Loss billable charge line type.  <b>Note:</b> On clicking the <b>Search</b>  icon that appears corresponding to the <b>SSL Billable Charge Line Type</b> field, the <b>Billable Charge Line Type Search</b> window appears.  On specifying the billable charge line type, the description of the billable charge line type appears corresponding to the <b>SSL Billable Charge Line Type</b> field.	No

Field Name	Field Description	Mandatory (Yes or No)
Domestic Provider Claim Billable Charge Line Type	<p>Used to specify the claim billable charge line type for domestic provider.</p> <p><b>Note:</b></p> <p>On clicking the <b>Search</b>  icon that appears corresponding to the <b>Domestic Provider Claim Billable Charge Line Type</b> field, the <b>Billable Charge Line Type Search</b> window appears.</p> <p>On specifying the billable charge line type, the description of the billable charge line type appears corresponding to the <b>Domestic Provider Claim Billable Charge Line Type</b> field.</p>	No
Markup or Markdown Billable Charge Line Type	<p>Used to specify the markup or markdown billable charge line type.</p> <p><b>Note:</b></p> <p>On clicking the <b>Search</b>  icon that appears corresponding to the <b>Markup or Markdown Billable Charge Line Type</b> field, the <b>Billable Charge Line Type Search</b> window appears.</p> <p>On specifying the billable charge line type, the description of the billable charge line type appears corresponding to the <b>Markup or Markdown Billable Charge Line Type</b> field.</p>	No
Rule Based Billing Eligibility Field	<p>Used to specify whether the rule based field is eligible for billing or not.</p> <p><b>Note:</b></p> <p>On clicking the <b>Search</b>  icon that appears corresponding to the <b>Rule Based Billing Eligibility Field</b> field, the <b>Field Search</b> window appears.</p> <p>On specifying the field, the description of the field appears corresponding to the <b>Rule Based Billing Eligibility Field</b> field.</p>	No

Field Name	Field Description	Mandatory (Yes or No)
Rule Based Markup or Markdown Eligibility Field	<p>Used to specify whether the rule based markup or markdown field is eligible for billing or not.</p> <p><b>Note:</b></p> <p>On clicking the <b>Search</b>  icon that appears corresponding to the <b>Rule Based Markup or Markdown Eligibility Field</b> field, the <b>Field Search</b> window appears.</p> <p>On specifying the field, the description of the field appears corresponding to the <b>Rule Based Markup or Markdown Eligibility Field</b> field.</p>	No
Rule Based Domestic Provider Claim Eligibility Field	<p>Used to specify the rule based domestic provider for claim eligibility field.</p> <p><b>Note:</b></p> <p>On clicking the <b>Search</b>  icon that appears corresponding to the <b>Rule Based Domestic Provider Claim Eligibility Field</b> field, the <b>Field Search</b> window appears.</p> <p>On specifying the field, the description of the field appears corresponding to the <b>Rule Based Domestic Provider Claim Eligibility Field</b> field.</p>	No

2. Enter the required details in the **SSL-Specific Additional Data** section.
3. Click **Save**.

The SSL-Specific Additional data is added in the pricing rule type.

### **Related Topics**

For more information on...	See...
How to define a specific stop-loss (SSL) pricing rule type	<a href="#">Defining a Specific Stop-Loss (SSL) Pricing Rule Type</a> on page 2386
How to edit the specific stop-loss (SSL) pricing rule type	<a href="#">Editing a Specific Stop-Loss (SSL) Pricing Rule Type</a> on page 2391

## **Editing a Specific Stop-Loss (SSL) Pricing Rule Type**

### **Prerequisites**

To edit the specific stop-loss (SSL) pricing rule type, you should have:

- Business Object **C1-PricingRuleSSL** defined for pricing rule.
- Pricing rule type category for specific stop-loss (SSL) defined in the application

### **Procedure**

To edit the specific stop-loss (SSL) pricing rule type:

1. Click the **Admin** link in the **Application** toolbar.

A list appears.

- From the **Admin** menu, select **P** and then click **Pricing Rule Type**.

A sub-menu appears.

- Click the **Search** option from the **Pricing Rule Type** sub-menu.

The **Pricing Rule Type** screen appears.

- In the **Pricing Rule Type List** zone, click the **Edit** (✎) icon in the **Edit** column corresponding to the pricing rule type for specific stop-loss (SSL) whose details you want to edit.

The **Specific Stop-Loss (SSL) Pricing Rule Type** screen appears. It contains the following sections:

- **Main** – Used to specify basic details about the specific stop-loss pricing rule type.
- **Related Pricing Rule Types** – Used to define the pricing rule types which are related to the parent pricing rule type.
- **Transaction Field Mapping** – Used to specify the transaction related data mapped to the pricing rule type
- **Algorithms** – Used to define the algorithms used for the pricing rule type.
- **Additional Data** – Used to specify the additional information about the pricing rule type.
- **Price Items** – Used to define the price items assigned to the pricing rule type.
- **Price Item Parameters** – Used to define the price item parameters in the pricing rule type.
- **Characteristics** – Used to define the characteristics for the pricing rule type.
- **SSL-Specific Additional Data** – Used to specify the specific stop-loss additional data.

The **Main** section contains the following fields:

Field Name	Field Description	Mandatory (Yes or No)
Pricing Rule Type	Displays the pricing rule type.	Not applicable
Description	Used to specify the description for the pricing rule type.	Yes
Detailed Description	Used to specify additional information about the pricing rule type.	No
Related Transaction Business Object	Used to indicate the pricing rule business object. The valid values are: <ul style="list-style-type: none"> <li>• Claim Pricing Rule</li> <li>• Aggregate Stop-Loss (ASL) Pricing Rule</li> <li>• Specific Stop-Loss (SSL) Pricing Rule</li> <li>• Retention Type Claim Based Pricing Rule</li> <li>• Retention Type Enrollment Based Pricing Rule</li> </ul>	Yes
Business Object	Displays the pricing rule type business object for specific stop-loss.	Not applicable
Status	Used to indicate the status of the pricing rule type. The valid values are: <ul style="list-style-type: none"> <li>• Active</li> <li>• Inactive</li> </ul>	Yes



Field Name	Field Description	Mandatory (Yes or No)
Primary	Used to select the checkbox if the pricing rule type is primary.	No
Pricing Rule Type Category	Used to indicate the pricing rule type category for the pricing rule type. The valid values are: <ul style="list-style-type: none"> <li>• Claim</li> <li>• Aggregate Stop-Loss</li> <li>• Specific Stop-Loss</li> <li>• Retention Type Claim Based</li> <li>• Retention Type Enrollment Based</li> </ul>	Yes

**Tip:** Alternatively, you can click the **Edit** button in the **Pricing Rule Type** zone to edit the pricing rule type for specific stop-loss.

5. Modify the details in the **Main** section, if required.
6. Add, edit, or remove the related pricing rule types in the primary pricing rule type, if required.
7. Modify the transaction field mapping in the primary pricing rule type, if required.
8. Add, edit, or remove algorithms with the pricing rule type, if required.
9. Modify the additional data for the pricing rule type, if required.
10. Add, edit, or remove pricing items in the pricing rule type, if required.
11. Add, edit, or remove price item parameters in the pricing rule type, if required.
12. Add, edit, or remove characteristics for the pricing rule type, if required.
13. Modify the SSL-Specific data in the pricing rule type, if required.
14. Click **Save**.

The changes made to the specific stop-loss pricing rule type are saved.

### **Related Topics**

For more information on...	See...
<b>Pricing Rule Type</b> screen	<a href="#">Pricing Rule Type</a> on page 2343
<b>Pricing Rule Type List</b> zone	<a href="#">Pricing Rule Type List</a> on page 2344
<b>Pricing Rule Type</b> zone	<a href="#">Pricing Rule Type</a> on page 2347
How to add the related pricing rule types in the primary pricing rule type	<a href="#">Adding Related Pricing Rule Types in a Primary Pricing Rule Type</a>
How to define the transaction field mapping in the primary pricing rule type	<a href="#">Defining Transaction Field Mapping in a Primary Pricing Rule Type</a>
How to associate algorithms with the pricing rule type	<a href="#">Associating Algorithms with a Pricing Rule Type</a>
How to define additional data for the pricing rule type	<a href="#">Defining Additional Data for a Pricing Rule Type</a>
How to add pricing items in the pricing rule type	<a href="#">Adding Price Items in a Pricing Rule Type</a>

For more information on...	See...
How to add price item parameters in the pricing rule type	<a href="#">Adding a Price Item Parameter in a Pricing Rule Type</a>
How to define characteristics for the pricing rule type	<a href="#">Defining Characteristics for a Pricing Rule Type</a>
How to add the SSL-Specific data in the pricing rule type	<a href="#">Adding the SSL-Specific Data in a Pricing Rule Type</a> on page 2389

## Deleting a Specific Stop-Loss (SSL) Pricing Rule Type

### Procedure

To delete a specific stop-loss pricing rule type:

1. Click the **Admin** link in the **Application** toolbar.  
A list appears.
2. From the **Admin** menu, select **P** and then click **Pricing Rule Type**.  
A sub-menu appears.
3. Click the **Search** option from the **Pricing Rule Type** sub-menu.  
The **Pricing Rule Type** screen appears.
4. In the **Pricing Rule Type List** zone, click the **Delete** (🗑️) icon in the **Delete** column corresponding to the specific stop-loss pricing rule type that you want to delete.

A message appears confirming whether you want to delete the specific stop-loss pricing rule type.

**Note:** You can delete a specific stop-loss pricing rule type only when it is not yet used in the system.

**Tip:** Alternatively, you can delete a specific stop-loss pricing rule type by clicking the **Delete** button in the **Pricing Rule Type** zone.

5. Click **OK**.  
The specific stop-loss pricing rule type is deleted.

### Related Topics

For more information on...	See...
<b>Pricing Rule Type</b> screen	<a href="#">Pricing Rule Type</a> on page 2343
<b>Pricing Rule Type List</b> zone	<a href="#">Pricing Rule Type List</a> on page 2344
<b>Pricing Rule Type</b> zone	<a href="#">Pricing Rule Type</a> on page 2347

## Viewing the Specific Stop-Loss (SSL) Pricing Rule Type Details

### Procedure

To view the details of a specific stop-loss pricing rule type:

1. Click the **Admin** link in the **Application** toolbar.  
A list appears.
2. From the **Admin** menu, select **P** and then click **Pricing Rule Type**.

A sub-menu appears.

- Click the **Search** option from the **Pricing Rule Type** sub-menu.

The **Pricing Rule Type** screen appears.

- In the **Pricing Rule Type List** zone, click the **Broadcast**  icon corresponding to the specific stop-loss pricing rule type whose details you want to view.

The **Pricing Rule Type** zone appears.

- View the details of the specific stop-loss pricing rule type in the **Pricing Rule Type** zone.

### **Related Topics**

<b>For more information on...</b>	<b>See...</b>
<b>Pricing Rule Type</b> screen	<a href="#">Pricing Rule Type</a> on page 2343
<b>Pricing Rule Type List</b> zone	<a href="#">Pricing Rule Type List</a> on page 2344
<b>Pricing Rule Type</b> zone	<a href="#">Pricing Rule Type</a> on page 2347

## **Defining a Specific Stop-Loss Pricing Rule for a Parent Customer**

### **Prerequisites**

To define a specific stop-loss pricing rule for a parent customer, you should have:

- Business Object **C1-PricingRule** defined for pricing rule.
- Business Object **C1-PricingRuleSSL** defined for specific stop-loss pricing rule.
- Pricing rule type defined in the application.
- Price item defined in the application.
- Rate option defined in the application.
- Pricing rule usage defined in the application.
- SSL accumulation level defined in the application.
- Settlement frequency defined in the application.
- Underwriter review defined in the application.

### **Procedure**

To define a specific stop-loss pricing rule for a parent customer:

- Search for the account, person, or policy whose pricing details you want to view in the **Customer 360° View** screen.
- In the **Search Results** section, click the **View** () icon corresponding to the account, person, or policy whose pricing details you want to view.

The **Account**, **Person**, or **Policy** tab in the **Customer 360° Information** screen appears.

- Click the **Pricing** tab and then click the **Add** link in the upper right corner of the **Parent Customer Pricing Rules** zone.

The **Pricing Rule** screen appears. It contains the following fields:

<b>Field Name</b>	<b>Field Description</b>	<b>Mandatory (Yes or No)</b>
Person Name	Displays the person name.	Not applicable

Field Name	Field Description	Mandatory (Yes or No)
Person Type	Displays the person type.	Not applicable
Pricing Rule Type	Used to indicate the pricing rule type to create the pricing rule.  <b>Note:</b> You can create a specific stop-loss pricing rule using the <b>Pricing Rule Type</b> for specific stop-loss.	Yes

4. Click **OK**.

The **Specific Stop-Loss (SSL) Pricing Rule** screen appears. It contains the following sections:

- **Customer Information** – Displays the customer information.
- **Main** – Used to specify basic details about the specific stop-loss pricing rule.
- **Accumulation Parameters** – Used to define the accumulation parameters based on which you want to accumulate the specific stop-loss for the transactions which are processed in the run-in or active period of the policy.
- **Run-In Parameters** – Used to define run-in parameters in the run-in period of the policy.
- **Lasering and Exclusion** – Used to define the lasering and exclusion information to inherit the accumulation parameters.
- **Characteristics** – Used to define the characteristics for a specific stop-loss pricing rule.

The **Customer Information** section contains the following fields:

Field Name	Field Description	Mandatory (Yes or No)
Parent Customer Information	Displays the parent customer information	Not applicable
Pricing Rule Type	Indicates the pricing rule type.	Not applicable

The **Main** section contains the following fields:

Field Name	Field Description	Mandatory (Yes or No)
Price Item	Used to indicate the price item which you want to define for pricing.	Yes
Pricing Start Date	Used to specify the pricing rule start date.  <b>Note:</b> This field is enabled when an option from <b>Price Item</b> field is selected. By default it displays the <b>Policy Start Date</b> .	Yes
Pricing End Date	Used to specify the pricing rule end date.  <b>Note:</b> This field is enabled when an option from <b>Price Item</b> field is selected. By default it displays the <b>Policy End Date</b> .	Yes

Field Name	Field Description	Mandatory (Yes or No)
Rate Option	Used to indicate the rate option which you want to use for defining the specific stop-loss pricing rule for the price item.	Yes
Pricing Rule Usage	<p>Used to indicate whether the pricing rule is used only for pricing or for pricing and billing. The valid values are:</p> <ul style="list-style-type: none"> <li>• Pricing</li> <li>• Pricing and Billing</li> </ul> <div style="border: 1px solid black; padding: 2px; margin-top: 5px;"> <p><b>Note:</b> This field is enabled when an option from <b>Price Item</b> field is selected.</p> </div>	Yes
SSL Accumulation Level	<p>Used to indicate whether the specific stop-loss must be accumulated at the member or main subscriber level. The valid values are:</p> <ul style="list-style-type: none"> <li>• Member</li> <li>• Main Subscriber</li> </ul>	
Settlement Frequency	<p>Used to indicate the settlement frequency which helps to determine the bill after date. The valid values are:</p> <ul style="list-style-type: none"> <li>• <b>Immediately</b> – The bill after date is not calculated. The specific stop-loss billable charge is billed immediately in the next cycle.</li> <li>• <b>Manually (At Required Intervals)</b> – The bill after date specified in the <b>Manual Settlement Bill After Date</b> parameter while executing the <b>C1-BCSSL</b> batch is stamped on the specific stop-loss billable charge.</li> <li>• <b>Never</b> – The bill after date specified in the <b>Manual Settlement Bill After Date</b> parameter while executing the <b>C1-BCSSL</b> batch is stamped on the specific stop-loss billable charge.</li> <li>• <b>Yearly</b> – The bill after date in the specific stop-loss billable charge is set to the pricing end date.</li> </ul> <div style="border: 1px solid black; padding: 2px; margin-top: 5px;"> <p><b>Note:</b> This field is disabled when you select <b>Pricing and Billing</b> option from the <b>Pricing Rule Usage</b> field.</p> </div>	Yes

Field Name	Field Description	Mandatory (Yes or No)
Underwriter Review	Used to indicate whether the underwriter settlement review flag is on or off. The valid values are: <ul style="list-style-type: none"> <li>• Yes</li> <li>• No</li> </ul>	Yes
Claim Template	Used to indicate the claim template to define the claim pricing rule for a parent customer. <div style="border: 1px solid black; padding: 2px; margin-top: 5px;"> <b>Note:</b> This field is enabled for selection when an option from <b>Price Item</b> field is selected. </div>	Yes

- Enter the required details in the **Main** section.
- Define accumulation parameters in a specific stop-loss pricing rule, if required.

**Note:** The **Accumulation Parameters** section appears only when an option from the **Price Item** field is selected.

- Define run-in parameters in a specific stop-loss pricing rule, if required.

**Note:** The **Run-In Parameters** section appears only when an option from the **Price Item** field is selected.

- Define lasering and exclusion information in a specific stop-loss pricing rule, if required.

**Note:** The **Lasering and Exclusion** section appears only when an option from the **Price Item** field is selected.

- Define characteristics for a specific stop-loss pricing rule, if required.

- Click **Save**.

The specific stop-loss pricing rule for a parent customer is defined.

### **Related Topics**

For more information on...	See...
<b>Customer 360° Information – Pricing</b> tab	<a href="#">Customer 360° Information - Pricing</a> on page 229
<b>Parent Customer Pricing Rules</b> zone	<a href="#">Parent Customer Pricing Rules</a> on page 231
How to define accumulation parameters in a specific stop-loss pricing rule	<a href="#">Defining Accumulation Parameters in a Specific Stop-Loss Pricing Rule</a> on page 2398
How to define run in parameters in a specific stop-loss pricing rule	<a href="#">Defining Run-in Parameters in a Specific Stop-Loss Pricing Rule</a> on page 2400
How to define lasering and exclusion information in a specific stop-loss pricing rule	<a href="#">Defining Lasering and Exclusion Information in a Specific Stop-Loss Pricing Rule</a> on page 2401
How to define characteristics for a specific stop-loss pricing rule	<a href="#">Defining Characteristics for a Specific Stop-Loss Pricing Rule</a> on page 2402

## **Defining Accumulation Parameters in a Specific Stop-Loss Pricing Rule**

### **Procedure**

To define accumulation parameters in a specific stop-loss pricing rule:

- Ensure that the **Accumulation Parameters** section is expanded only when you have selected an option from the **Price Item** field of **Main** section while defining a specific stop-loss pricing rule.

The **Accumulation Parameters** section contains the following fields:

Field Name	Field Description	Mandatory (Yes or No)
Accumulation Group ID	Displays blank field, accumulation group ID is generated when accumulation parameter values are defined for a specific stop-loss.	Not applicable
Incurred Start Date	Used to specify the incurred start date based on which you want to accumulate the specific stop-loss.  <b>Note:</b> The accumulated specific stop-loss for claim transactions are processed in the run-in or active period of the policy.	Yes
Incurred End Date	Used to specify the incurred end date based on which you want to accumulate the specific stop-loss.  <b>Note:</b> The accumulated specific stop-loss for claim transactions are processed in the run-in or active period of the policy.	Yes
SSL Payout Limit	Used to specify the maximum limit defined for specific stop-loss at the member or main subscriber level.	Yes
Paid Start Date	Used to specify the paid start date based on which you want to accumulate the specific stop-loss.  <b>Note:</b> The accumulated specific stop-loss for claim transactions are processed in the run-in or active period of the policy.	Yes
Paid End Date	Used to specify the paid end date based on which you want to accumulate the specific stop-loss.  <b>Note:</b> The accumulated specific stop-loss for claim transactions are processed in the run-in or active period of the policy.	Yes
Settlement Days	Used to indicate the settlement days which helps to calculate the settlement date.  <b>Note:</b> Settlement date is calculated as the pricing end date, incurred end date, or paid end date whichever is later added with the settlement days.	Yes
Compute Aggregate SSL (ASSL)	Used to indicate whether the aggregate specific stop-loss (ASSL) should be calculated or not during the <b>C1-BCSSL</b> batch run for each bill group. The valid values are: <ul style="list-style-type: none"> <li>• Yes</li> <li>• No</li> </ul>	Yes

Field Name	Field Description	Mandatory (Yes or No)
ASSL Credit Count	Used to indicate that the aggregate specific stop-loss amount beyond the ASSL limit will be paid by the insurance company to the ASSL credit account.  <b>Note:</b> This field is enabled when you select <b>Yes</b> option from the <b>Compute Aggregate SSL (ASSL)</b> field.	Yes
ASSL Limit	<b>Note:</b> This field is enabled when you select <b>Yes</b> option from the <b>Compute Aggregate SSL (ASSL)</b> field.	Yes

- Enter the required details in the **Accumulation Parameters** section.
- Click **Save**.

The accumulation parameters are defined in the specific stop-loss pricing rule.

### **Related Topics**

For more information on...	See...
How to define a specific stop-loss pricing rule for a parent customer	<a href="#">Defining a Specific Stop-Loss Pricing Rule for a Parent Customer</a> on page 2395
How to edit a specific stop-loss pricing rule of a parent customer	<a href="#">Editing a Specific Stop-Loss Pricing Rule of a Parent Customer</a> on page 2404

## **Defining Run-in Parameters in a Specific Stop-Loss Pricing Rule**

### **Procedure**

To define run-in parameters in a specific stop-loss pricing rule:

- Ensure that the **Run-In Parameters** section is expanded only when you have selected an option from the **Price Item** field of **Main** section while defining a specific stop-loss pricing rule.

The **Run-In Parameters** section contains the following fields:

Field Name	Field Description	Mandatory (Yes or No)
Run-In	Used to specify whether the run-in parameters of the run-in period of policy are to be considered or not in a specific stop-loss pricing	No
Incurred Start Date	Used to specify the incurred start date based on the run-in period of the policy in the specific stop-loss.  <b>Note:</b> This field is enabled only when you select the checkbox for the <b>Run-In</b> field.	Yes
Incurred End Date	Used to specify the incurred end date based on the run-in period of the policy in the specific stop-loss.  <b>Note:</b> This field is enabled only when you select the checkbox for the <b>Run-In</b> field.	Yes



Field Name	Field Description	Mandatory (Yes or No)
Paid Start Date	Used to specify the paid start date based on the run-in period of the policy in the specific stop-loss.  <b>Note:</b> This field is enabled only when you select the checkbox for the <b>Run-In</b> field.	Yes
Paid End Date	Used to specify the paid end date based on the run-in period of the policy in the specific stop-loss.  <b>Note:</b> This field is enabled only when you select the checkbox for the <b>Run-In</b> field.	Yes

- Enter the required details in the **Run-In Parameters** section.
- Click **Save**.

The run-in parameters are defined in the specific stop-loss pricing rule.

#### Related Topics

For more information on...	See...
How to define a specific stop-loss pricing rule for a parent customer	<a href="#">Defining a Specific Stop-Loss Pricing Rule for a Parent Customer</a> on page 2395
How to edit a specific stop-loss pricing rule of a parent customer	<a href="#">Editing a Specific Stop-Loss Pricing Rule of a Parent Customer</a> on page 2404

## Defining Lasering and Exclusion Information in a Specific Stop-Loss Pricing Rule

### Prerequisites

To define lasering and exclusion information in a specific stop-loss pricing rule, you should have:

- Lasering or exclusion level defined in the application.
- Exception type defined in the application.

### Procedure

To define lasering and exclusion information in a specific stop-loss pricing rule:

- Ensure that the **Lasering and Exclusion** section is expanded only when you have selected an option from the **Price Item** field of **Main** section while defining a specific stop-loss pricing rule.

The **Lasering and Exclusion** section contains the following columns in a grid:

Column Name	Column Description	Mandatory (Yes or No)
Accumulation Group ID	Displays blank column, accumulation group ID is generated when accumulation parameter values are defined for a specific stop-loss.	Not applicable
Level Identifier	Used to specify the lasering or exclusion level identifier.	Yes

Column Name	Column Description	Mandatory (Yes or No)
Lasering or Exclusion Level	Used to indicate the lasering or exclusion in a specific stop-loss. The valid values are: <ul style="list-style-type: none"> <li>• Main Subscriber</li> <li>• Member</li> <li>• Provider</li> </ul>	Yes
Exception Type	Used to indicate the exception type. The valid values are: <ul style="list-style-type: none"> <li>• Lasering</li> <li>• Exclusion</li> </ul> <p><b>Note:</b> This field displays <b>Exclusion</b> option and is disabled on selection of <b>Provider</b> option from the <b>Lasering or Exclusion Level</b> column.</p>	Yes
Comments	Used to specify the comments.	No
Lasered Amount	Used to specify the lasered amount. <p><b>Note:</b> This field is disabled when <b>Exclusion</b> option is selected from the <b>Exception Type</b> column.</p>	Yes (Conditional) <p><b>Note:</b> This column is mandatory when <b>Lasering</b> option is selected from the <b>Exception Type</b> column.</p>

- Enter the required details in the **Lasering and Exclusion** section.
- If you want to define more than one lasering and exclusion information in a specific stop-loss pricing rule, click the **Add (+)** icon and then repeat step 2.

**Note:** However, if you want to remove a lasering and exclusion information from the specific stop-loss pricing rule, click the **Delete (🗑)** icon corresponding to the level identifier.

- Click **Save**.

The lasering and exclusion information is defined in a specific stop-loss pricing rule.

### **Related Topics**

For more information on...	See...
How to define a specific stop-loss pricing rule for a parent customer	<a href="#">Defining a Specific Stop-Loss Pricing Rule for a Parent Customer</a> on page 2395
How to edit the specific stop-loss pricing rule for a parent customer	<a href="#">Editing a Specific Stop-Loss Pricing Rule of a Parent Customer</a> on page 2404

## **Defining Characteristics for a Specific Stop-Loss Pricing Rule**

### **Prerequisites**

To define characteristics for a specific stop-loss pricing rule, you should have:

- Characteristic types defined in the application (where the characteristic entity is set to **Pricing Rule**)

### **Procedure**

To define characteristics for a specific stop-loss pricing rule:

1. Ensure that the **Characteristics** section is expanded when you are defining or editing a pricing rule.

The **Characteristics** section contains the following columns in a grid:

Column Name	Column Description	Mandatory (Yes or No)
Effective Date	Used to specify the date from when the characteristic is effective for the specific stop-loss pricing rule.	Yes (Conditional) <b>Note:</b> This field is required when you are defining a characteristic for the specific stop-loss pricing rule.
Characteristic Type	Used to indicate the characteristic type. <b>Note:</b> The list includes only those characteristic types where the characteristic entity is set to <b>Pricing Rule</b> .	Yes (Conditional) <b>Note:</b> This field is required when you are defining a characteristic for the specific stop-loss pricing rule.
Characteristic Value	Used to specify the value for the characteristic type. <b>Note:</b> If you select a predefined characteristic type, the <b>Search</b>  icon appears corresponding to the <b>Characteristic Value</b> field. On clicking the <b>Search</b> icon, the <b>Predefined Characteristic Search</b> window appears. On specifying the value for a predefined characteristic type, the description of the characteristic value appears corresponding to the <b>Characteristic Value</b> field.	Yes (Conditional) <b>Note:</b> This field is required when you are defining a characteristic for the specific stop-loss pricing rule.

2. Enter the required details in the **Characteristics** section.
3. If you want to define more than one characteristic for the specific stop-loss pricing rule, click the **Add**  icon and then repeat step 2.

**Note:** However, if you want to remove a characteristic from the specific stop-loss pricing rule, click the **Delete**  icon corresponding to the characteristic.

4. Click **Save**.

The characteristics are defined for the specific stop-loss pricing rule.

### **Related Topics**

For more information on...	See...
How to define a specific stop-loss pricing rule for a parent customer	<a href="#">Defining a Specific Stop-Loss Pricing Rule for a Parent Customer</a> on page 2395
How to edit the specific stop-loss pricing rule for a parent customer	<a href="#">Editing a Specific Stop-Loss Pricing Rule of a Parent Customer</a> on page 2404

## Editing a Specific Stop-Loss Pricing Rule of a Parent Customer



### Prerequisites

To edit a specific stop-loss pricing rule of a parent customer, you should have:

- Business Object **C1-PricingRuleSSL** defined for specific stop-loss pricing rule.
- Pricing rule usage defined in the application.
- SSL accumulation level defined in the application.
- Underwriter review defined in the application.

### Procedure

To edit a specific stop-loss pricing rule of a parent customer:

1. Search for the account, person, or policy whose pricing details you want to view in the **Customer 360° View** screen.
2. In the **Search Results** section, click the **View** () icon corresponding to the account, person, or policy whose pricing details you want to view. The **Account, Person, or Policy** tab in the **Customer 360° Information** screen appears.
3. Click the **Pricing** tab, in the **Parent Customer Pricing Rules** zone click the **Edit** () icon in the **Edit** column corresponding to the pricing rule type for specific stop-loss whose specific stop-loss pricing rule details you want to view.

The **Specific Stop-Loss (SSL) Pricing Rule** screen appears. It contains the following sections:

- **Customer Information** – Displays the customer information.
- **Main** – Used to specify basic details about the specific stop-loss pricing rule.
- **Accumulation Parameters** – Used to define the accumulation parameters based on which you want to accumulate the specific stop-loss for the transactions which are processed in the run-in or active period of the policy.
- **Run-In Parameters** – Used to define run-in parameters in the run-in period of the policy.
- **Lasering and Exclusion** – Used to define the lasering and exclusion information to inherit the accumulation parameters.
- **Characteristics** – Used to define the characteristics for a specific stop-loss pricing rule.

The **Customer Information** section contains the following fields:

Field Name	Field Description	Mandatory (Yes or No)
Parent Customer Information	Displays the parent customer information	Not applicable
Pricing Rule Type	Indicates the pricing rule type.	Not applicable

The **Main** section contains the following fields:

Field Name	Field Description	Mandatory (Yes or No)
Price Item	Indicates the price item defined for pricing.	Not applicable
Pricing Start Date	Used to specify the pricing rule start date.	Yes
Pricing End Date	Used to specify the pricing rule end date.	Yes

Field Name	Field Description	Mandatory (Yes or No)
Rate Option	Indicates the rate option used for defining the specific stop-loss pricing rule for the price item.	Not applicable
Pricing Rule Usage	Used to indicate whether the pricing rule is used only for pricing or for pricing and billing. The valid values are: <ul style="list-style-type: none"> <li>• Pricing</li> <li>• Pricing and Billing</li> </ul>	Yes
SSL Accumulation Level	Used to indicate whether the specific stop-loss must be accumulated at the member or main subscriber level. The valid values are: <ul style="list-style-type: none"> <li>• Member</li> <li>• Main Subscriber</li> </ul>	
Settlement Frequency	Indicates the settlement frequency to determine the bill after date. The valid values are: <ul style="list-style-type: none"> <li>• <b>Immediately</b> – The bill after date is not calculated. The specific stop-loss billable charge is billed immediately in the next cycle.</li> <li>• <b>Manually (At Required Intervals)</b> – The bill after date specified in the <b>Manual Settlement Bill After Date</b> parameter while executing the <b>C1-BCSSL</b> batch is stamped on the specific stop-loss billable charge.</li> <li>• <b>Never</b> –</li> <li>• <b>Yearly</b> – The bill after date in the specific stop-loss billable charge is set to the pricing end date.</li> </ul> <div style="border: 1px solid black; padding: 5px; margin-top: 10px;"> <p><b>Note:</b> This field is disabled when you select <b>Pricing and Billing</b> option from the <b>Pricing Rule Usage</b> field.</p> </div>	Not applicable
Underwriter Review	Used to indicate whether the underwriter settlement review flag is on or off. The valid values are: <ul style="list-style-type: none"> <li>• Yes</li> <li>• No</li> </ul>	Yes

4. Modify the details in the **Main** section, if required.
5. Modify the accumulation parameters in a specific stop-loss pricing rule, if required.
6. Modify the run-in parameters in a specific stop-loss pricing rule, if required.
7. Add, edit, or remove the lasering and exclusion information for the specific stop-loss pricing rule, if required.
8. Add, edit, or remove characteristics for the specific stop-loss pricing rule, if required.

## 9. Click **Save**.

The changes made to a specific stop-loss pricing rule for a parent customer are saved.

### Related Topics

For more information on...	See...
<b>Customer 360° Information – Pricing</b> tab	<a href="#">Customer 360° Information - Pricing</a> on page 229
<b>Parent Customer Pricing Rules</b> zone	<a href="#">Parent Customer Pricing Rules</a> on page 231
How to define accumulation parameters in a specific stop-loss pricing rule	<a href="#">Defining Accumulation Parameters in a Specific Stop-Loss Pricing Rule</a> on page 2398
How to define run-in parameters in a specific stop-loss pricing rule	<a href="#">Defining Run-in Parameters in a Specific Stop-Loss Pricing Rule</a> on page 2400
How to define lasering and exclusion information in a specific stop-loss pricing rule	<a href="#">Defining Lasering and Exclusion Information in a Specific Stop-Loss Pricing Rule</a> on page 2401
How to define characteristics for a specific stop-loss pricing rule	<a href="#">Defining Characteristics for a Specific Stop-Loss Pricing Rule</a> on page 2402

## Viewing a Specific Stop-Loss Pricing Rule of a Parent Customer

### Procedure

To view a specific stop-loss pricing rule of a parent customer:

1. Search for the account, person, or policy whose pricing details you want to view in the **Customer 360° View** screen.
2. In the **Search Results** section, click the **View** () icon corresponding to the account, person, or policy whose pricing details you want to view. The **Account, Person, or Policy** tab in the **Customer 360° Information** screen appears.
3. Click the **Pricing** tab.
4. In the **Parent Customer Pricing Rules** zone, click the link in the **Pricing Rule Information** column corresponding to the specific stop-loss pricing rule type whose specific stop-loss pricing rule you want to view.

The **Pricing Rule** screen appears. It contains the following zone:

- **Specific Stop-Loss** – Displays the pricing rule specific stop-loss details for a parent customer. It contains the following sections:
    - **Main** – Displays the basic details about the specific stop-loss pricing rule.
    - **Accumulation Parameters** – Displays the accumulation parameters based on which accumulated specific stop-loss for the transactions are processed in the run-in or active period of the policy.
    - **Run-In Parameters** – Displays the run-in parameters in the run-in period of the policy.
    - **Lasering and Exclusion** – Displays the lasering and exclusion information that inherits the accumulation parameters
    - **Characteristics** – Displays the characteristics defined for the specific stop-loss pricing rule.
5. View the basic details of specific stop-loss pricing rule in the **Main** zone.
  6. View the accumulated parameters in the **Accumulation Parameters** zone.
  7. View the run-in parameters in the **Run-In Parameters** zone.

8. View the lasering and exclusion information in the **Lasering and Exclusion** zone.
9. View the characteristics defined for the specific stop-loss pricing rule in the **Characteristics** zone.



### Related Topics

For more information on...	See...
Customer 360° Information – Pricing tab	<a href="#">Customer 360° Information - Pricing</a> on page 229
Parent Customer Pricing Rules zone	<a href="#">Parent Customer Pricing Rules</a> on page 231
Pricing Rule screen	<a href="#">Pricing Rule (Used for Viewing)</a> on page 2688
Specific Stop-Loss zone	<a href="#">Specific Stop-Loss</a> on page 2697

## Deleting a Specific Stop-Loss Pricing Rule of a Parent Customer

### Procedure

To delete a specific stop-loss pricing rule of a parent customer:

1. Search for the account, person, or policy whose pricing details you want to view in the **Customer 360° View** screen.
2. In the **Search Results** section, click the **View** () icon corresponding to the account, person, or policy whose pricing details you want to view.  
The **Account, Person, or Policy** tab in the **Customer 360° Information** screen appears.
3. Click the **Pricing** tab, in the **Parent Customer Pricing Rules** zone, click the **Delete** () icon in the **Delete** column corresponding to the specific stop-loss pricing rule type whose specific stop-loss pricing rule you want to delete.  
A message appears confirming whether you want to delete the specific stop-loss pricing rule.
4. Click **OK**.  
The specific stop-loss pricing rule is deleted.

### Related Topics

For more information on...	See...
Customer 360° Information – Pricing tab	<a href="#">Customer 360° Information - Pricing</a> on page 229
Parent Customer Pricing Rules zone	<a href="#">Parent Customer Pricing Rules</a> on page 231

## Defining a Specific Stop-Loss Pricing Rule for a Bill Group

### Prerequisites

To define a specific stop-loss pricing rule for a bill group, you should have:

- Business Object **C1-PricingRule** defined for pricing rule.
- Business Object **C1-PricingRuleSSL** defined for specific stop-loss pricing rule.
- Pricing rule type defined in the application.
- Policy status defined in the application.
- Price item defined in the application.
- Rate option defined in the application.

### Procedure

To define a specific stop-loss pricing rule for a bill group:

1. Search for the account, person, or policy whose pricing details you want to view in the **Customer 360° View** screen.
2. In the **Search Results** section, click the **View** () icon corresponding to the account, person, or policy whose pricing details you want to view.

The **Account, Person, or Policy** tab in the **Customer 360° Information** screen appears.

3. Click the **Pricing** tab and then click the **Add** link in the upper right corner of the **Bill Group ASO Policy Pricing Rules** zone.

The **Pricing Rule** screen appears. It contains the following fields:

Field Name	Field Description	Mandatory (Yes or No)
Person Name	Displays the person name.	Not applicable
Person Type	Displays the person type.	Not applicable
Pricing Rule Type	Used to indicate the pricing rule type to create the pricing rule.  <b>Note:</b> You can create a specific stop-loss pricing rule using the <b>Pricing Rule Type</b> for specific stop-loss.	Yes
Pricing Group	Used to indicate the pricing group.	No
Policy Status	Used to indicate the policy status for pricing rule. The valid values are: <ul style="list-style-type: none"> <li>• In Force/Active</li> <li>• Post Runout</li> <li>• Runout</li> </ul> <b>Note:</b> Specific stop-loss pricing rule cannot be created for <b>Runout</b> or <b>Post Runout</b> policy status where the policy run out end date is missing.	Yes

4. Click **OK**.

The **Specific Stop-Loss (SSL) Pricing Rule** screen appears. It contains the following sections:

- **Customer Information** – Displays the customer information for bill group.
- **Main** – Used to specify basic details about the specific stop-loss pricing rule.
- **Accumulation Criteria** – Used to define the accumulation criteria in a specific stop-loss pricing rule.
- **Pricing Information** – Used to define stop-loss eligibility for claim line items.
- **Characteristics** – Used to define the characteristics for the specific stop-loss pricing rule.

The **Customer Information** section contains the following fields:

Field Name	Field Description	Mandatory (Yes or No)
Bill Group Information	Displays the bill group information.	Not applicable
Policy Start Date	Displays the policy start date.	Not applicable
Policy End Date	Displays the policy end date.	Not applicable



Field Name	Field Description	Mandatory (Yes or No)
Policy Status	Indicates the policy status for pricing rule. The valid values are: <ul style="list-style-type: none"> <li>In Force/Active</li> <li>Post Runout</li> <li>Runout</li> </ul>	Not applicable
Pricing Rule Type	Indicates the pricing rule type.	Not applicable

The **Main** section contains the following fields:

Field Name	Field Description	Mandatory (Yes or No)
Price Item	Used to indicate the price item. <b>Note:</b> Once an option is selected for this field, the field appears disabled.	Yes
Parent Customer's SSL Pricing Rules	Used to indicate the pricing date range derived from the parent customer's specific stop-loss pricing rule. <b>Note:</b> This field is enabled for selection when an option from <b>Price Item</b> field is selected.	Yes
Pricing Start Date	Displays the pricing rule start date. <b>Note:</b> This field displays the <b>Policy Start Date</b> .	Not applicable
Pricing End Date	Displays the pricing rule end date. <b>Note:</b> This field displays the <b>Policy End Date</b> .	Not applicable
Rate Option	Used to indicate the rate option to define the specific stop-loss pricing rule for the price item. <b>Note:</b> Rate options in this field appears for selection, only when you select an option from the <b>Price Item</b> field.	Yes

- Enter the required details in the **Main** section.
- Define accumulation criteria in a specific stop-loss pricing rule, if required.

**Note:**  
The **Accumulation Criteria** section appears only when an option from **Parent Customer's SSL Pricing Rules** field is selected.  
You can also define the **Accumulation Criteria** for each rule in a specific stop-loss pricing rule.

- Define stop-loss eligibility for claim line items, if required.

**Note:**

The **Pricing Information** section appears only when an option from **Parent Customer's SSL Pricing Rules** field is selected.

You can also define the **Pricing Information** for each rule in a specific stop-loss pricing rule.

8. Define characteristics for a specific stop-loss pricing rule, if required.
9. Click **Save**.

The specific stop-loss pricing rule for a bill group is defined.

**Note:** A price list and price assignment is created, the price list created is assigned to the specific stop-loss pricing rule.

**Related Topics**

For more information on...	See...
<b>Customer 360° Information – Pricing</b> tab	<a href="#">Customer 360° Information - Pricing</a> on page 229
<b>Bill Group ASO Policy Pricing Rules</b> zone	<a href="#">Bill Group ASO Policy Pricing Rules</a> on page 237
How to define accumulation criteria in a specific stop-loss pricing rule	<a href="#">Defining Accumulation Criteria in a Specific Stop-Loss Pricing Rule</a> on page 2410
How to define claim pricing information in a specific stop loss pricing rule	<a href="#">Defining Claim Pricing Information in a Specific Stop Loss Pricing Rule</a> on page 2412
How to define characteristics for a specific stop-loss pricing rule	<a href="#">Defining Characteristics for a Specific Stop-Loss Pricing Rule</a> on page 2402







**Defining Accumulation Criteria in a Specific Stop-Loss Pricing Rule****Procedure**

To define accumulation criteria in a specific stop-loss pricing rule:

1. Ensure that the **Accumulation Criteria** section is expanded only when you have selected an option from the **Parent Customer's SSL Pricing Rules** field of **Main** section while defining or editing a specific stop-loss pricing rule.

The **Accumulation Criteria** section contains the following fields:

Field Name	Field Description	Mandatory (Yes or No)
Accumulation Group ID	Displays blank field, accumulation group ID is generated when accumulation criteria values are defined for a specific stop-loss.	Not applicable
Run-In Maximum Limit	Used to specify the maximum specific stop-loss limit defined for the member when the claim transactions are received in the run-in period of the policy.  <b>Note:</b> This field is enabled only when the start date and end date selected from the <b>Parent Customer's SSL Pricing Rules</b> field of <b>Main</b> section is greater than today's date.	Yes

Field Name	Field Description	Mandatory (Yes or No)									
SSL Limit	Used to specify whether the SSL limit indicating that the specific stop-loss amount beyond this limit will be paid by the insurance company.	Yes									
Price Item	Used to specify the price item information.  <b>Note:</b> On clicking the <b>Search</b>  icon that appears corresponding to the <b>Price Item</b> field, the <b>Price Item Search</b> window appears.	No									
Price Item Parameters	This field contains the following columns: <table border="1" data-bbox="532 611 1031 1791"> <thead> <tr> <th>Column Name</th> <th>Column Description</th> <th>Mandatory (Yes or No)</th> </tr> </thead> <tbody> <tr> <td>Price Item Parameter</td> <td>Used to specify multiple parameters based on which you want to determine the price item utilization.  <b>Note:</b> On clicking the <b>Search</b>  icon that appears corresponding to the <b>Price Item Parameter</b> field, the <b>Price Item Parameter Search</b> window appears.</td> <td>No</td> </tr> <tr> <td>Parameter Value</td> <td>Used to specify the value of the parameter.  <b>Note:</b> On selecting the <b>Price Item Parameter</b>, the <b>Search</b>  icon appears corresponding to this field, and on clicking the icon, the <b>Parameter Value Search</b> window appears.</td> <td>No</td> </tr> </tbody> </table>	Column Name	Column Description	Mandatory (Yes or No)	Price Item Parameter	Used to specify multiple parameters based on which you want to determine the price item utilization.  <b>Note:</b> On clicking the <b>Search</b>  icon that appears corresponding to the <b>Price Item Parameter</b> field, the <b>Price Item Parameter Search</b> window appears.	No	Parameter Value	Used to specify the value of the parameter.  <b>Note:</b> On selecting the <b>Price Item Parameter</b> , the <b>Search</b>  icon appears corresponding to this field, and on clicking the icon, the <b>Parameter Value Search</b> window appears.	No	No
Column Name	Column Description	Mandatory (Yes or No)									
Price Item Parameter	Used to specify multiple parameters based on which you want to determine the price item utilization.  <b>Note:</b> On clicking the <b>Search</b>  icon that appears corresponding to the <b>Price Item Parameter</b> field, the <b>Price Item Parameter Search</b> window appears.	No									
Parameter Value	Used to specify the value of the parameter.  <b>Note:</b> On selecting the <b>Price Item Parameter</b> , the <b>Search</b>  icon appears corresponding to this field, and on clicking the icon, the <b>Parameter Value Search</b> window appears.	No									

- Enter the required details in the **Accumulation Criteria** section.

- If you want to define more than one price item in the accumulation group, click the **Add (+)** icon and then repeat step 2.

**Note:** However, if you want to remove a price item from the accumulation group, click the **Delete (🗑)** icon corresponding to the price item.

- If you want to define more than one price item parameters for the price item, click the **Add (+)** icon and then repeat step 2.

**Note:** However, if you want to remove a price item parameter from the price item, click the **Delete (🗑)** icon corresponding to the price item parameter.

- Click **Save**.

The accumulation criteria is defined in the specific stop-loss pricing rule.

- You can define accumulation rules for each rule in a specific stop-loss pricing rule.

**Note:** You can exclude a rule from the specific stop-loss pricing by selecting the **Exclude Rule** checkbox.

### Related Topics

For more information on...	See...
How to define a specific stop-loss pricing rule for a bill group	<a href="#">Defining a Specific Stop-Loss Pricing Rule for a Bill Group</a> on page 2407
How to edit a specific stop-loss pricing rule of a bill group	<a href="#">Editing a Specific Stop-Loss Pricing Rule of a Bill Group</a> on page 2417

## Defining Claim Pricing Information in a Specific Stop Loss Pricing Rule

### Procedure

To define the stop-loss eligibility for claim line items:

- Ensure that the **Pricing Information** section is expanded only when you have selected an option from the **Parent Customer's SSL Pricing Rules** field of **Main** section while defining or editing a specific stop-loss pricing rule.

The **Pricing Information** section contains the following section:

- **Claim Pricing Rule** – Used to indicate the claim pricing rule. It contains the following sub-sections:
  - **Domestic Provider Claims** – Used to specify the domestic provider claim while calculating specific stop-loss.
  - **Markup or Markdown Values** – Used to define the markup or markdown values for billable charge line.
  - **Line Items** – Used to associate line items eligible for billing.

The **Claim Pricing Rule** section contains the following field:

Field Name	Field Description	Mandatory (Yes or No)
Effective Claim Pricing Rule	Used to indicate the claim pricing rule effective for pricing.	No

On clicking the **Reapply Claim Template** button to the right side of the **Effective Claim Pricing Rule** field you can reapply for claim pricing rule.

**Note:** The **Reapply Claim Template** button appears only when you are editing a specific stop-loss.

The **Domestic Provider Claims** section contains the following field:

Field Name	Field Description	Mandatory (Yes or No)
Exclude SSL (Percentage)	Used to specify the domestic provider claim billable charge line excluding the specific stop-loss in percentage to create domestic provider claim calculation lines.	No

The **Markup or Markdown Values** section contains the following fields:

Field Name	Field Description	Mandatory (Yes or No)
Pricing Strategy	Indicates the pricing strategy. The valid values are: <ul style="list-style-type: none"> <li>• Markdown</li> <li>• Markup</li> <li>• None</li> </ul>	Not applicable
Markup or Markdown Type	Indicates the markup or markdown value type for claim line items. The valid values are: <ul style="list-style-type: none"> <li>• Flat Amount</li> <li>• Percentage</li> </ul>	Not applicable
Markup or Markdown Amount	Displays the markup or markdown amount. <b>Note:</b> This field displays amount when <b>Markup or Markdown Type</b> field is <b>Flat Amount</b> .	Not applicable

The **Line Items** section contains the following fields:

Field Name	Field Description	Mandatory (Yes or No)
Sequence	Displays the sequence number for the line items.	Not applicable
Line Item	Displays the billing line items.	Not applicable
Eligible for Specific Stop-Loss	Used to specify whether the line item is eligible or not eligible for specific stop-loss.	No
Markup or Markdown Percentage Eligibility	Displays whether the line item is eligible or not eligible for markup or markdown percentage. The valid values are: <ul style="list-style-type: none"> <li>• Eligible</li> <li>• Not Eligible</li> </ul>	Not applicable
Markup or Markdown Percentage	Displays the percentage for markup or markdown value.	Not applicable

2. Select the required details in the **Claim Pricing Rule** section, if required.

3. Enter the required details in the **Domestic Provider Claims** section, if required.
4. Select the required details in the **Line Items** section, if required.
5. Click **Save**.

The claim line items are defined in the specific stop-loss pricing rule.

6. You can define eligibility claim line items for each rule in a specific stop-loss pricing rule.

**Note:** You can exclude a rule from the specific stop-loss pricing by selecting the **Exclude Rule** checkbox.

### Related Topics

For more information on...	See...
How to define a specific stop-loss pricing rule for a bill group	<a href="#">Defining a Specific Stop-Loss Pricing Rule for a Bill Group</a> on page 2407
How to edit a specific stop-loss pricing rule of a bill group	<a href="#">Editing a Specific Stop-Loss Pricing Rule of a Bill Group</a> on page 2417

## Defining a Specific Stop-Loss Pricing Rule for a Bill Group Using a Pricing Group

### Prerequisites

To define a specific stop-loss pricing rule for a bill group using a pricing group, you should have:

- Business Object **C1-PricingRule** defined for pricing rule.
- Business Object **C1-PricingRuleSSL** defined for specific stop-loss pricing rule.
- Pricing rule type defined in the application.
- Pricing group defined in the application.
- Policy status defined in the application.
- Price item defined in the application.
- Rate option defined in the application.

### Procedure

To define a specific stop-loss pricing rule for a bill group using a pricing group:

1. Search for the account, person, or policy whose pricing details you want to view in the **Customer 360° View** screen.
2. In the **Search Results** section, click the **View** () icon corresponding to the account, person, or policy whose pricing details you want to view.  
The **Account**, **Person**, or **Policy** tab in the **Customer 360° Information** screen appears.
3. Click the **Pricing** tab and then click the **Add** link in the upper right corner of the **Bill Group ASO Policy Pricing Rules** zone.

The **Pricing Rule** screen appears. It contains the following fields:

Field Name	Field Description	Mandatory (Yes or No)
Person Name	Displays the person name.	Not applicable
Person Type	Displays the person type.	Not applicable

Field Name	Field Description	Mandatory (Yes or No)
Pricing Rule Type	Used to indicate the pricing rule type to create the pricing rule.  <b>Note:</b> You can create a specific stop-loss pricing rule using the <b>Pricing Rule Type</b> for specific stop-loss.	Yes
Pricing Group	Used to indicate the pricing group.	Yes
Policy Status	Used to indicate the policy status for pricing rule. The valid values are: <ul style="list-style-type: none"> <li>• In Force/Active</li> <li>• Post Runout</li> <li>• Runout</li> </ul> <b>Note:</b> Specific stop-loss pricing rule cannot be created for <b>Runout</b> or <b>Post Runout</b> policy status where the policy run out End Date is missing.	Yes

#### 4. Click **OK**.

The **Specific Stop-Loss (SSL) Pricing Rule** screen appears. It contains the following sections:

- **Customer Information** – Displays the customer information for bill group using pricing group.
- **Main** – Used to specify basic details about the claim pricing rule.
- **Markup or Markdown Values** – Used to define the markup or markdown values for billable charge line for each rule.
- **Line Items** – Used to associate line items eligible for billing for each rule.
- **Characteristics** – Used to define the characteristics for the claim pricing rule.

The **Customer Information** section contains the following fields:

Field Name	Field Description	Mandatory (Yes or No)
Bill Group Information	Displays the bill group information.	Not applicable
Policy Start Date	Displays the policy start date.	Not applicable
Policy End Date	Displays the policy end date.	Not applicable
Policy Status	Indicates the policy status for pricing rule. The valid values are: <ul style="list-style-type: none"> <li>• In Force/Active</li> <li>• Post Runout</li> <li>• Runout</li> </ul>	Not applicable
Pricing Group	Displays the pricing group.	Not applicable
Pricing Rule Type	Indicates the pricing rule type.	Not applicable

The **Main** section contains the following fields:

Field Name	Field Description	Mandatory (Yes or No)
Price Item	Used to indicate the price item. <b>Note:</b> Once an option is selected for this field, the field appears disabled.	Yes
Parent Customer's SSL Pricing Rules	Used to indicate the pricing date range derived from the parent customer's specific stop-loss pricing rule. <b>Note:</b> This field is enabled for selection when an option from <b>Price Item</b> field is selected.	Yes
Pricing Start Date	Displays the pricing rule start date.	Yes
Pricing End Date	Displays the pricing rule end date.	Yes
Rate Option	Used to indicate the rate option to define the specific stop-loss pricing rule for the price item. <b>Note:</b> Rate options in this field appears for selection, only when you select an option from the <b>Price Item</b> field.	Yes

- Enter the required details in the **Main** section.
- Define accumulation criteria for each rule in a specific stop-loss pricing rule pricing rule, if required.

**Note:** The **Accumulation Criteria** section appears in the rule section and the rule section appears only when an option from **Parent Customer's SSL Pricing Rules** field is selected.

- Define stop-loss eligibility for claim line items, if required.

**Note:** The **Pricing Information** section appears in the rule section and the rule section appears only when an option from **Parent Customer's SSL Pricing Rules** field is selected.

- Define characteristics for a specific stop-loss pricing rule, if required.
- Click **Save**.

The specific stop-loss pricing rule for a bill group using a pricing group is defined.

**Note:** A price list and price assignment is created, the price list created is assigned to the specific stop-loss pricing rule.

### Related Topics

For more information on...	See...
<b>Customer 360° Information – Pricing</b> tab	<a href="#">Customer 360° Information - Pricing</a> on page 229
<b>Bill Group ASO Policy Pricing Rules</b> zone	<a href="#">Bill Group ASO Policy Pricing Rules</a> on page 237
How to define Accumulation Criteria in a specific stop-loss pricing rule	<a href="#">Defining Accumulation Criteria in a Specific Stop-Loss Pricing Rule</a> on page 2410
How to define claim pricing information in a specific stop loss pricing rule	<a href="#">Defining Claim Pricing Information in a Specific Stop Loss Pricing Rule</a> on page 2412



For more information on...	See...
How to define characteristics for a specific stop-loss pricing rule	<a href="#">Defining Characteristics for a Specific Stop-Loss Pricing Rule</a> on page 2402

## Editing a Specific Stop-Loss Pricing Rule of a Bill Group



### Prerequisites

To edit a specific stop-loss pricing rule of a bill group, you should have:

- Business Object **C1-PricingRuleSSL** defined for specific stop-loss pricing rule.

### Procedure

To edit a specific stop-loss pricing rule of a bill group:

1. Search for the account, person, or policy whose pricing details you want to view in the **Customer 360° View** screen.
2. In the **Search Results** section, click the **View** () icon corresponding to the account, person, or policy whose pricing details you want to view.  
The **Account, Person, or Policy** tab in the **Customer 360° Information** screen appears.
3. Click the **Pricing** tab, in the **Bill Group ASO Policy Pricing Rules** zone click the **Edit** () icon in the **Edit** column corresponding to the pricing rule type for specific stop-loss whose specific stop-loss pricing rule details you want to view.

The **Specific Stop-Loss (SSL) Pricing Rule** screen appears. It contains the following sections:

- **Customer Information** – Displays the customer information for bill group.
- **Main** – Displays the basic details about the specific stop-loss pricing rule.
- **Accumulation Criteria** – Used to define the accumulation criteria in a specific stop-loss pricing rule.
- **Pricing Information** – Used to define stop-loss eligibility for claim line items.
- **Characteristics** – Used to define the characteristics for the specific stop-loss pricing rule.

The **Customer Information** section contains the following fields:

Field Name	Field Description	Mandatory (Yes or No)
Bill Group Information	Displays the bill group information.	Not applicable
Policy Start Date	Displays the policy start date.	Not applicable
Policy End Date	Displays the policy end date.	Not applicable
Policy Status	Indicates the policy status for pricing rule. The valid values are: <ul style="list-style-type: none"> <li>• In Force/Active</li> <li>• Post Runout</li> <li>• Runout</li> </ul>	Not applicable
Pricing Rule Type	Indicates the pricing rule type.	Not applicable

The **Main** section contains the following fields:

Field Name	Field Description	Mandatory (Yes or No)
Price Item	Indicates the price item.	Not applicable

Field Name	Field Description	Mandatory (Yes or No)
Parent Customer's SSL Pricing Rules	Indicates the pricing date range derived from the parent customer's specific stop-loss pricing rule.	Not applicable
Pricing Start Date	Displays the pricing rule start date.	Not applicable
Pricing End Date	Displays the pricing rule end date.	Not applicable
Rate Option	Indicates the rate option of the specific stop-loss pricing rule for the price item.	Not applicable

- Modify the accumulation criteria in a specific stop-loss pricing rule, if required.

**Note:** You can add, edit, or remove price item and its price item parameters in the accumulation criteria for a specific stop-loss, if required.

- Modify the stop-loss eligibility for claim line items, if required.

**Note:** This section also consists of a button, **Reapply Claim Template**, on clicking the button a message occurs indicating that updating the claim template will reset all the default fields on the claim pricing rule.

- Add, edit, or remove characteristics for a specific stop-loss pricing rule, if required.
- Click **Save**.

The changes made to a specific stop-loss pricing rule for a bill group are saved.

### Related Topics

For more information on...	See...
<b>Customer 360° Information – Pricing</b> tab	<a href="#">Customer 360° Information - Pricing</a> on page 229
<b>Bill Group ASO Policy Pricing Rules</b> zone	<a href="#">Bill Group ASO Policy Pricing Rules</a> on page 237
How to define accumulation criteria in a specific stop-loss pricing rule	<a href="#">Defining Accumulation Criteria in a Specific Stop-Loss Pricing Rule</a> on page 2410
How to define claim pricing information in a specific stop loss pricing rule	<a href="#">Defining Claim Pricing Information in a Specific Stop Loss Pricing Rule</a> on page 2412
How to define characteristics for a specific stop-loss pricing rule	<a href="#">Defining Characteristics for a Specific Stop-Loss Pricing Rule</a> on page 2402

## Viewing a Specific Stop-Loss Pricing Rule of a Bill Group

### Procedure

To view a claim pricing rule of a bill group:

- Search for the account, person, or policy whose pricing details you want to view in the **Customer 360° View** screen.
- In the **Search Results** section, click the **View** () icon corresponding to the account, person, or policy whose pricing details you want to view.

The **Account**, **Person**, or **Policy** tab in the **Customer 360° Information** screen appears.

- Click the **Pricing** tab.
- In the **Bill Group ASO Policy Information** zone, click the **Broadcast** () icon corresponding to the bill group whose specific stop-loss pricing rule bill group details you want to view.

- In the **Bill Group ASO Policy Pricing Rules** zone, click the link in the **Pricing Rule Information** column corresponding to the specific stop-loss pricing rule type whose specific stop-loss pricing rule bill group you want to view.

The **Pricing Rule** screen appears. It contains the following zone:

- **Specific Stop-Loss** – Displays the pricing rule specific stop-loss details for a bill group. It contains the following sections:
    - **Main** – Displays the basic details about the specific stop-loss pricing rule.
    - **Accumulation Criteria** – Displays the accumulation criteria in a specific stop-loss pricing rule.
    - **Pricing Information** – Displays the stop-loss eligibility for claim line items.
    - **Characteristics** – Displays the characteristics defined for the specific stop-loss pricing rule.
- View the basic details of specific stop-loss pricing rule in the **Main** section.
  - View the accumulation criteria in the **Markup or Markdown Values** section.
  - View the stop-loss eligibility for claim line items in the **Line Items** section.
  - View the characteristics defined for the specific stop-loss pricing rule in the **Characteristics** section.



### Related Topics

For more information on...	See...
Customer 360° Information – Pricing tab	<a href="#">Customer 360° Information - Pricing</a> on page 229
Bill Group ASO Policy Pricing Rules zone	<a href="#">Bill Group ASO Policy Pricing Rules</a> on page 237
Pricing Rule screen	<a href="#">Pricing Rule (Used for Viewing)</a> on page 2688
Specific Stop-Loss zone	<a href="#">Specific Stop-Loss</a> on page 2697

## Deleting a Specific Stop-Loss Pricing Rule of a Bill Group

### Procedure

To delete a specific stop-loss pricing rule of a bill group:

- Search for the account, person, or policy whose pricing details you want to view in the **Customer 360° View** screen.
- In the **Search Results** section, click the **View** () icon corresponding to the account, person, or policy whose pricing details you want to view.  
The **Account, Person, or Policy** tab in the **Customer 360° Information** screen appears.
- Click the **Pricing** tab, in the **Bill Group ASO Policy Pricing Rules** zone, click the **Delete** () icon in the **Delete** column corresponding to the specific stop-loss pricing rule type whose specific stop-loss pricing rule you want to delete.  
A message appears confirming whether you want to delete the specific stop-loss pricing rule.
- Click **OK**.  
The specific stop-loss pricing rule is deleted.

### Related Topics

For more information on...	See...
Customer 360° Information – Pricing tab	<a href="#">Customer 360° Information - Pricing</a> on page 229
Bill Group ASO Policy Pricing Rules zone	<a href="#">Bill Group ASO Policy Pricing Rules</a> on page 237

## Aggregate Stop-Loss (ASL) Pricing

---

ASL provides a ceiling on the eligible expenses that an employer would pay, in total for all members or subscribers, during a contract period. The amount that exceeds this limit will be paid by the insurance company.

You can define an aggregate stop-loss pricing rule at the parent customer and bill group levels. The aggregate stop-loss pricing rule at the bill group level takes precedence over the aggregate stop-loss pricing rule at the parent customer level. You can define aggregate stop-loss pricing rules for parent customers and bill groups from the **Customer 360° Information** screen. You can define an aggregate stop-loss pricing rule using an aggregate stop-loss pricing rule type. It is the aggregate stop-loss pricing rule type which helps the system to determine:

- Business object using which the aggregate stop-loss pricing rule should be created in the system.

**Note:** The aggregate stop-loss pricing rule type is not a primary pricing rule type. It inherits the attributes from a claim pricing rule type where it is included as a related pricing rule type.

- Algorithm which should be triggered while validating a transaction.

**Note:** An algorithm type for validating a transaction is not shipped from the product. You need to create a custom algorithm type, if required.

- Algorithms which should be triggered while deriving account and price item for a transaction.

**Note:** You must create an algorithm using the **C1\_ACCPRISL** algorithm type and attach it to the **Account and Price Item Derivation** system event.

- Post-processing algorithm which should be triggered once the aggregate stop-loss pricing rule is derived.

**Note:** A post-processing algorithm type is not shipped from the product. You need to create a custom algorithm type, if required.

- Price items for which you can define aggregate stop-loss pricing rules using the aggregate stop-loss pricing rule type.
- Rate options that you can use while defining the pricing for a price item.
- Different type of account to which the price item should be billed based on the specified priority.

**Note:** Ideally, the price item parameters should not be specified in an aggregate stop-loss pricing rule type. The price item parameters which are specified in the claim pricing rule type are used for accumulating aggregate stop-loss.

- Additional information, such as:
  - Identifier which helps to determine whether the aggregate stop-loss should be calculated for claim transactions which are received during the run-in period of the policy.
  - ASL billable charge line type using which you want to create aggregate stop-loss billable charges.
  - Domestic provider claim billable charge line type using which you want to create domestic provider claim calculation lines.
  - Markup or markdown billable charge line type using which you want to create markup or markdown calculation lines.
  - Transaction field which you want to use in the rules as the output parameter to determine whether the line item is eligible for billing.
  - Transaction field which you want to use in the rules as the output parameter to determine whether the markup or markdown calculation line is eligible for billing.

- Transaction field which you want to use in the rules as the output parameter to determine whether the domestic provider claim calculation line is eligible for billing.
- ASL limit price item whose effective retention type enrollment based pricing should be used to calculate the enrollment based limit when the ASL Limit (During Policy Period) or ASL Limit (During Settlement Period) field is set to Enrollment Based Limit, Enrollment Based or Minimum ASL Limit (Whichever is Greater), or Percentage of Enrollment Based Limit in the aggregate stop-loss pricing rule which is defined for a parent customer.

Once an aggregate stop-loss pricing rule type is defined, you can create aggregate stop-loss pricing rules using the aggregate stop-loss pricing rule type. While defining an aggregate stop-loss pricing rule for a parent customer, you need to specify the following:

- Price item for which you want to define the pricing.
- Parent customer's SSL pricing rule from which you want to inherit the settlement frequency, settlement days, accumulation parameters (such as incurred start date, incurred end date, paid start date, and paid end date).

**Note:** The pricing date range is derived from the parent customer's specific stop-loss pricing rule because the specific stop-loss and aggregate stop-loss pricing rules for a parent customer should have the same date range.

- Rate option which you want to use while defining the aggregate stop-loss pricing.
- Settlement frequency which helps to determine the bill after date. The valid values are:
  - Immediately – If you select this option from the list, the bill after date is not calculated. The aggregate stop-loss billable charge is billed immediately in the next bill cycle.
  - Manually (At Required Intervals) - If you select this option from the list, the bill after date which is specified in the **Manual Settlement Date** parameter while executing the **C1-BCASL** batch is stamped on the aggregate stop-loss billable charge.
  - Monthly - If you select this option from the list, the bill after date which is specified in the **Manual Settlement Date** parameter while executing the **C1-BCASL** batch is stamped on the aggregate stop-loss billable charge.
  - Yearly – If you select this option from the list, the bill after date in the aggregate stop-loss billable charge is set to the pricing end date.
- Account in which the aggregate stop-loss amount should be credited.
- Accumulation parameters (such as incurred start date, incurred end date, paid start date, paid end date, etc.) based on which you want to accumulate the aggregate stop-loss for the claim transactions which are processed in the run-in or active period of the policy.
- The maximum limit defined for aggregate stop-loss at the parent customer level.
- Settlement days which helps to calculate the settlement date (i.e. pricing end date, incurred end date, or paid end date whichever is later + settlement days)
- Whether the ASL limit should be set to either of the following during the policy period:
  - Policy Based Limit
  - Enrollment Based or Minimum ASL Limit (Whichever is Greater)
  - Enrollment Based Limit
  - Percentage of Enrollment Based Limit
- Whether the ASL limit should be set to either of the following during the settlement period:
  - Policy Based Limit
  - Enrollment Based or Minimum ASL Limit (Whichever is Greater)
  - Enrollment Based Limit

However, while defining an aggregate stop-loss pricing rule for a bill group, you need to specify the following:

- The status of the policy for which you want to define the aggregate stop-loss pricing rule.
- Price item for which you want to define the pricing.
- Parent customer's ASL pricing rule from which you want to inherit the pricing date range.

**Note:** The pricing date range is derived from the parent customer's aggregate stop-loss pricing rule because the aggregate stop-loss pricing rules for parent customer and bill group should have the same date range.

- Rate option which you want to use while defining the aggregate stop-loss pricing.
- Whether the aggregate stop-loss calculated for the claim transactions which are mapped to the specified price items and price item parameters should be accumulated.
- Whether line items in a claim pricing rule are eligible for aggregate stop-loss.

**Note:** By default, the line items where the pricing rule type category is set to Aggregate Stop-Loss appear in the Line Items section. If you want to set aggregate stop-loss eligibility for the line items which belong to a particular claim pricing rule, you must select the respective claim pricing rule.

- Whether certain percentage of ASL should be excluded while calculating aggregate stop-loss for domestic provider claim.

You can also specify a pricing group while defining an aggregate stop-loss pricing rule for a bill group. If you specify a pricing group while defining an aggregate stop-loss pricing rule for a bill group, you will have to define the following details for each rule defined in the pricing group:

- Whether the aggregate stop-loss calculated for the claim transactions which are mapped to the specified price items and price item parameters should be accumulated.
- Whether line items in a claim pricing rule are eligible for aggregate stop-loss.

**Note:** By default, the line items where the pricing rule type category is set to Aggregate Stop-Loss appear in the Line Items section. If you want to set aggregate stop-loss eligibility for the line items which belong to a particular claim pricing rule, you must select the respective claim pricing rule.

- Whether certain percentage of ASL should be excluded while calculating aggregate stop-loss for domestic provider claim.

Once an aggregate stop-loss pricing rule is defined for a parent customer and bill group, the system creates one price assignment, one price list, and one price list assignment.

## Defining a Aggregate Stop-Loss (ASL) Pricing Rule Type

### Prerequisites

To define an aggregate stop-loss (SSL) pricing rule type, you should have:

- Business Object **C1-PricingRuleTypeASL** defined for pricing rule type.
- Business Object **C1-PricingRuleASL** defined for pricing rule.
- Pricing rule type category for aggregate stop-loss defined in the application

### Procedure

To define an aggregate stop-loss pricing rule type:

1. Click the **Admin** link in the **Application** toolbar.  
A list appears.
2. From the **Admin** menu, select **P** and then click **Pricing Rule Type**.  
A sub-menu appears.

- Click the **Add** option from the **Pricing Rule Type** sub-menu.

The **Select Business Object** screen appears. It contains the following field:

Field Name	Field Description	Mandatory (Yes or No)
Pricing Rule Type Business Object	Used to indicate the business object using which you want to create the pricing rule type.  <b>Note:</b> You can create an aggregate stop-loss pricing rule type using the <b>Aggregate Stop-Loss (ASL) Pricing Rule Type</b> business object.	Yes

**Tip:** Alternatively, you can access this screen by clicking the **Add** button in the **Page Title** area of the **Pricing Rule Type** screen.

- Select the **Aggregate Stop-Loss (ASL) Pricing Rule Type** business object.
- Click **OK**.

The **Aggregate Stop-Loss (ASL) Pricing Rule Type** screen appears. It contains the following sections:

- Main** – Used to specify basic details about the aggregate stop-loss pricing rule type.
- Related Pricing Rule Types** – Used to define the pricing rule types which are related to the parent pricing rule type.
- Transaction Field Mapping** – Used to specify the transaction related data mapped to the pricing rule type
- Algorithms** – Used to define the algorithms used for the pricing rule type.
- Additional Data** – Used to specify the additional information about the pricing rule type.
- Price Items** – Used to define the price items assigned to the pricing rule type.
- Price Item Parameters** – Used to define the price item parameters in the pricing rule type.
- Characteristics** – Used to define the characteristics for the pricing rule type.
- ASL-Specific Additional Data** – Used to specify the aggregate stop-loss related additional data.

The **Main** section contains the following fields:

Field Name	Field Description	Mandatory (Yes or No)
Pricing Rule Type	Used to specify the pricing rule type.	Yes
Description	Used to specify the description for the pricing rule type.	Yes
Detailed Description	Used to specify additional information about the pricing rule type.	No
Related Transaction Business Object	Used to indicate the pricing rule business object. The valid values are: <ul style="list-style-type: none"> <li>Claim Pricing Rule</li> <li>Aggregate Stop-Loss (ASL) Pricing Rule</li> <li>Specific Stop-Loss (SSL) Pricing Rule</li> <li>Retention Type Claim Based Pricing Rule</li> <li>Retention Type Enrollment Based Pricing Rule</li> </ul>	Yes

Field Name	Field Description	Mandatory (Yes or No)
Business Object	Indicate the pricing rule type business object for aggregate stop-loss.	Not applicable
Status	Used to indicate the status of the pricing rule type. The valid values are: <ul style="list-style-type: none"> <li>Active</li> <li>Inactive</li> </ul>	Yes
Primary	Used to select the checkbox if the pricing rule type is primary.	No
Pricing Rule Type Category	Used to indicate the pricing rule type category for the pricing rule type. The valid values are: <ul style="list-style-type: none"> <li>Claim</li> <li>Aggregate Stop-Loss</li> <li>Specific Stop-Loss</li> <li>Retention Type Claim Based</li> <li>Retention Type Enrollment Based</li> </ul>	Yes

- Enter the required details in the **Main** section.
- Add the related pricing rule types in the primary pricing rule type, if required.

**Note:** **Related Pricing Rule Types** section appears only when the pricing rule type is primary.

- Define the transaction field mapping in the primary pricing rule type, if required.

**Note:** **Transaction Field Mapping** section appears only when the pricing rule type is primary.

- Associate algorithms with the pricing rule type, if required.
- Define additional data for the pricing rule type, if required.
- Add pricing items in the pricing rule type, if required.
- Add price item parameters in the pricing rule type, if required.
- Define characteristics for the pricing rule type, if required.
- Add the ASL-Specific additional data in the pricing rule type, if required.
- Click **Save**.

The aggregate stop-loss pricing rule type is defined.

### Related Topics

For more information on...	See...
<b>Pricing Rule Type</b> screen	<a href="#">Pricing Rule Type</a> on page 2343
How to add the related pricing rule types in the primary pricing rule type	<a href="#">Adding Related Pricing Rule Types in a Primary Pricing Rule Type</a>
How to define the transaction field mapping in the primary pricing rule type	<a href="#">Defining Transaction Field Mapping in a Primary Pricing Rule Type</a>
How to associate algorithms with the pricing rule type	<a href="#">Associating Algorithms with a Pricing Rule Type</a>



For more information on...	See...
How to define additional data for the pricing rule type	<a href="#">Defining Additional Data for a Pricing Rule Type</a>
How to add pricing items in the pricing rule type	<a href="#">Adding Price Items in a Pricing Rule Type</a>
How to add price item parameters in the pricing rule type	<a href="#">Adding a Price Item Parameter in a Pricing Rule Type</a>
How to define characteristics for the pricing rule type	<a href="#">Defining Characteristics for a Pricing Rule Type</a>
How to add the ASL-Specific data in the pricing rule type	<a href="#">Adding the ASL-Specific Data in a Pricing Rule Type</a> on page 2425



## Adding the ASL-Specific Data in a Pricing Rule Type



### Procedure

To add the ASL-Specific additional data in a pricing rule type:

1. Ensure that the **ASL-Specific Additional Data** section is expanded when you are defining or editing a pricing rule type.

The **ASL-Specific Additional Data** section contains the following fields:

Field Name	Field Description	Mandatory (Yes or No)
ASL Billable Charge Line Type	Used to specify the Aggregate Stop-Loss billable charge line type.  <b>Note:</b> On clicking the <b>Search</b>  icon that appears corresponding to the <b>ASL Billable Charge Line Type</b> field, the <b>Billable Charge Line Type Search</b> window appears.  On specifying the billable charge line type, the description of the billable charge line type appears corresponding to the <b>ASL Billable Charge Line Type</b> field.	No
Domestic Provider Claim Billable Charge Line Type	Used to specify the claim billable charge line type for domestic provider.  <b>Note:</b> On clicking the <b>Search</b>  icon that appears corresponding to the <b>Domestic Provider Claim Billable Charge Line Type</b> field, the <b>Billable Charge Line Type Search</b> window appears.  On specifying the billable charge line type, the description of the billable charge line type appears corresponding to the <b>Domestic Provider Claim Billable Charge Line Type</b> field.	No

Field Name	Field Description	Mandatory (Yes or No)
Markup or Markdown Billable Charge Line Type	<p>Used to specify the markup or markdown billable charge line type.</p> <p><b>Note:</b></p> <p>On clicking the <b>Search</b>  icon that appears corresponding to the <b>Markup or Markdown Billable Charge Line Type</b> field, the <b>Billable Charge Line Type Search</b> window appears.</p> <p>On specifying the billable charge line type, the description of the billable charge line type appears corresponding to the <b>Markup or Markdown Billable Charge Line Type</b> field.</p>	No
Rule Based Billing Eligibility Field	<p>Used to specify whether the rule based field is eligible for billing or not.</p> <p><b>Note:</b></p> <p>On clicking the <b>Search</b>  icon that appears corresponding to the <b>Rule Based Billing Eligibility Field</b> field, the <b>Field Search</b> window appears.</p> <p>On specifying the field, the description of the field appears corresponding to the <b>Rule Based Billing Eligibility Field</b> field.</p>	No
Rule Based Markup or Markdown Eligibility Field	<p>Used to specify whether the rule based markup or markdown field is eligible for billing or not.</p> <p><b>Note:</b></p> <p>On clicking the <b>Search</b>  icon that appears corresponding to the <b>Rule Based Markup or Markdown Eligibility Field</b> field, the <b>Field Search</b> window appears.</p> <p>On specifying the field, the description of the field appears corresponding to the <b>Rule Based Markup or Markdown Eligibility Field</b> field.</p>	No

Field Name	Field Description	Mandatory (Yes or No)
Rule Based Domestic Provider Claim Eligibility Field	Used to specify the rule based domestic provider for claim eligibility field.  <b>Note:</b> On clicking the <b>Search</b>  icon that appears corresponding to the <b>Rule Based Domestic Provider Claim Eligibility Field</b> field, the <b>Field Search</b> window appears.  On specifying the field, the description of the field appears corresponding to the <b>Rule Based Domestic Provider Claim Eligibility Field</b> field.	No
ASL Limit Price Item	Used to specify the Aggregated Stop-Loss limit price item.	No

- Enter the required details in the **ASL-Specific Additional Data** section.
- Click **Save**.

The ASL-Specific Additional data is added in the pricing rule type.

### Related Topics

For more information on...	See...
How to define an aggregate stop-loss (ASL) pricing rule type	<a href="#">Defining a Aggregate Stop-Loss (ASL) Pricing Rule Type</a> on page 2422
How to edit the aggregate stop-loss (ASL) pricing rule type	<a href="#">Editing an Aggregate Stop-Loss (ASL) Pricing Rule Type</a> on page 2427

## Editing an Aggregate Stop-Loss (ASL) Pricing Rule Type

### Prerequisites

To edit the aggregate stop-loss (ASL) pricing rule type, you should have:

- Business Object **C1-PricingRuleASL** defined for pricing rule.
- Pricing rule type category for aggregate stop-loss (ASL) defined in the application

### Procedure

To edit the aggregate stop-loss (ASL) pricing rule type:

- Click the **Admin** link in the **Application** toolbar.  
A list appears.
- From the **Admin** menu, select **P** and then click **Pricing Rule Type**.  
A sub-menu appears.
- Click the **Search** option from the **Pricing Rule Type** sub-menu.  
The **Pricing Rule Type** screen appears.
- In the **Pricing Rule Type List** zone, click the **Edit**  icon in the **Edit** column corresponding to the pricing rule type for aggregate stop-loss (ASL) whose details you want to edit.

The **Aggregate Stop-Loss (ASL) Pricing Rule Type** screen appears. It contains the following sections:

- **Main** – Used to specify basic details about the aggregate stop-loss pricing rule type.
- **Related Pricing Rule Types** – Used to define the pricing rule types which are related to the parent pricing rule type.
- **Transaction Field Mapping** – Used to specify the transaction related data mapped to the pricing rule type
- **Algorithms** – Used to define the algorithms used for the pricing rule type.
- **Additional Data** – Used to specify the additional information about the pricing rule type.
- **Price Items** – Used to define the price items assigned to the pricing rule type.
- **Price Item Parameters** – Used to define the price item parameters in the pricing rule type.
- **Characteristics** – Used to define the characteristics for the pricing rule type.
- **ASL-Specific Additional Data** – Used to specify the aggregate stop-loss additional data.

The **Main** section contains the following fields:

Field Name	Field Description	Mandatory (Yes or No)
Pricing Rule Type	Displays the pricing rule type.	Not applicable
Description	Used to specify the description for the pricing rule type.	Yes
Detailed Description	Used to specify additional information about the pricing rule type.	No
Related Transaction Business Object	Used to indicate the pricing rule business object. The valid values are: <ul style="list-style-type: none"> <li>• Claim Pricing Rule</li> <li>• Aggregate Stop-Loss (ASL) Pricing Rule</li> <li>• Specific Stop-Loss (SSL) Pricing Rule</li> <li>• Retention Type Claim Based Pricing Rule</li> <li>• Retention Type Enrollment Based Pricing Rule</li> </ul>	Yes
Business Object	Displays the pricing rule type business object for aggregate stop-loss.	Not applicable
Status	Used to indicate the status of the pricing rule type. The valid values are: <ul style="list-style-type: none"> <li>• Active</li> <li>• Inactive</li> </ul>	Yes
Primary	Used to select the checkbox if the pricing rule type is primary.	No

Field Name	Field Description	Mandatory (Yes or No)
Pricing Rule Type Category	Used to indicate the pricing rule type category for the pricing rule type. The valid values are: <ul style="list-style-type: none"> <li>• Claim</li> <li>• Aggregate Stop-Loss</li> <li>• Specific Stop-Loss</li> <li>• Retention Type Claim Based</li> <li>• Retention Type Enrollment Based</li> </ul>	Yes

**Tip:** Alternatively, you can click the **Edit** button in the **Pricing Rule Type** zone to edit the pricing rule type for specific stop-loss.

5. Modify the details in the **Main** section, if required.
6. Add, edit, or remove the related pricing rule types in the primary pricing rule type, if required.
7. Modify the transaction field mapping in the primary pricing rule type, if required.
8. Add, edit, or remove algorithms with the pricing rule type, if required.
9. Modify the additional data for the pricing rule type, if required.
10. Add, edit, or remove pricing items in the pricing rule type, if required.
11. Add, edit, or remove price item parameters in the pricing rule type, if required.
12. Add, edit, or remove characteristics for the pricing rule type, if required.
13. Modify the ASL-Specific data in the pricing rule type, if required.
14. Click **Save**.

The changes made to the aggregate stop-loss pricing rule type are saved.

### **Related Topics**

For more information on...	See...
<b>Pricing Rule Type</b> screen	<a href="#">Pricing Rule Type</a> on page 2343
<b>Pricing Rule Type List</b> zone	<a href="#">Pricing Rule Type List</a> on page 2344
<b>Pricing Rule Type</b> zone	<a href="#">Pricing Rule Type</a> on page 2347
How to add the related pricing rule types in the primary pricing rule type	<a href="#">Adding Related Pricing Rule Types in a Primary Pricing Rule Type</a>
How to define the transaction field mapping in the primary pricing rule type	<a href="#">Defining Transaction Field Mapping in a Primary Pricing Rule Type</a>
How to associate algorithms with the pricing rule type	<a href="#">Associating Algorithms with a Pricing Rule Type</a>
How to define additional data for the pricing rule type	<a href="#">Defining Additional Data for a Pricing Rule Type</a>
How to add pricing items in the pricing rule type	<a href="#">Adding Price Items in a Pricing Rule Type</a>
How to add price item parameters in the pricing rule type	<a href="#">Adding a Price Item Parameter in a Pricing Rule Type</a>

For more information on...	See...
How to define characteristics for the pricing rule type	<a href="#">Defining Characteristics for a Pricing Rule Type</a>
How to add the ASL-Specific data in the pricing rule type	<a href="#">Adding the ASL-Specific Data in a Pricing Rule Type</a> on page 2425

## Deleting an Aggregate Stop-Loss (ASL) Pricing Rule Type

### Procedure

To delete an aggregate stop-loss pricing rule type:

1. Click the **Admin** link in the **Application** toolbar.  
A list appears.
2. From the **Admin** menu, select **P** and then click **Pricing Rule Type**.  
A sub-menu appears.
3. Click the **Search** option from the **Pricing Rule Type** sub-menu.  
The **Pricing Rule Type** screen appears.
4. In the **Pricing Rule Type List** zone, click the **Delete** (🗑️) icon in the **Delete** column corresponding to the aggregate stop-loss pricing rule type that you want to delete.  
A message appears confirming whether you want to delete the aggregate stop-loss pricing rule type.

**Note:** You can delete an aggregate stop-loss pricing rule type only when it is not yet used in the system.

**Tip:** Alternatively, you can delete an aggregate stop-loss pricing rule type by clicking the **Delete** button in the **Pricing Rule Type** zone.

5. Click **OK**.  
The aggregate stop-loss pricing rule type is deleted.

### Related Topics

For more information on...	See...
<b>Pricing Rule Type</b> screen	<a href="#">Pricing Rule Type</a> on page 2343
<b>Pricing Rule Type List</b> zone	<a href="#">Pricing Rule Type List</a> on page 2344
<b>Pricing Rule Type</b> zone	<a href="#">Pricing Rule Type</a> on page 2347

## Viewing the Aggregate Stop-Loss (ASL) Pricing Rule Type Details

### Procedure

To view the details of an aggregate stop-loss pricing rule type:

1. Click the **Admin** link in the **Application** toolbar.  
A list appears.
2. From the **Admin** menu, select **P** and then click **Pricing Rule Type**.  
A sub-menu appears.
3. Click the **Search** option from the **Pricing Rule Type** sub-menu.

The **Pricing Rule Type** screen appears.

4. In the **Pricing Rule Type List** zone, click the **Broadcast**  icon corresponding to the aggregate stop-loss pricing rule type whose details you want to view.

The **Pricing Rule Type** zone appears.

5. View the details of the aggregate stop-loss pricing rule type in the **Pricing Rule Type** zone.

### **Related Topics**

<b>For more information on...</b>	<b>See...</b>
<b>Pricing Rule Type</b> screen	<a href="#">Pricing Rule Type</a> on page 2343
<b>Pricing Rule Type List</b> zone	<a href="#">Pricing Rule Type List</a> on page 2344
<b>Pricing Rule Type</b> zone	<a href="#">Pricing Rule Type</a> on page 2347

## **Defining an Aggregate Stop-Loss Pricing Rule for a Parent Customer**

### **Prerequisites**

To define an aggregate stop-loss pricing rule for a parent customer, you should have:

- Business Object **C1-PricingRule** defined for pricing rule.
- Business Object **C1-PricingRuleASL** defined for aggregate stop-loss pricing rule.
- Pricing rule type defined in the application.
- Price item defined in the application.
- Rate option defined in the application.
- Settlement frequency defined in the application.
- Underwriter review defined in the application.

### **Procedure**

To define an aggregate stop-loss pricing rule for a parent customer:

1. Search for the account, person, or policy whose pricing details you want to view in the **Customer 360° View** screen.
2. In the **Search Results** section, click the **View**  icon corresponding to the account, person, or policy whose pricing details you want to view.

The **Account, Person, or Policy** tab in the **Customer 360° Information** screen appears.

3. Click the **Pricing** tab and then click the **Add** link in the upper right corner of the **Parent Customer Pricing Rules** zone.

The **Pricing Rule** screen appears. It contains the following fields:

<b>Field Name</b>	<b>Field Description</b>	<b>Mandatory (Yes or No)</b>
Person Name	Displays the person name.	Not applicable
Person Type	Displays the person type.	Not applicable

Field Name	Field Description	Mandatory (Yes or No)
Pricing Rule Type	Used to indicate the pricing rule type to create the pricing rule.  <b>Note:</b> You can create an aggregate stop-loss pricing rule using the <b>Pricing Rule Type</b> for aggregate stop-loss.	Yes

4. Click **OK**.

The **Aggregate Stop-Loss (ASL) Pricing Rule** screen appears. It contains the following sections:

- **Customer Information** – Displays the customer information.
- **Main** – Used to specify basic details about the aggregate stop-loss pricing rule.
- **Accumulation Parameters** – Used to define the accumulation parameters based on which you want to accumulate the aggregate stop-loss for the transactions which are processed in the run-in or active period of the policy.
- **Run-In Parameters** – Used to define run-in parameters in the run-in period of the policy.
- **Characteristics** – Used to define the characteristics for an aggregation stop-loss pricing rule.

The **Customer Information** section contains the following fields:

Field Name	Field Description	Mandatory (Yes or No)
Parent Customer Information	Displays the parent customer information	Not applicable
Pricing Rule Type	Indicates the pricing rule type.	Not applicable

The **Main** section contains the following fields:

Field Name	Field Description	Mandatory (Yes or No)
Price Item	Used to indicate the price item which you want to define for pricing.	Yes
Parent Customer's SSL or ASL Pricing Rules	Used to indicate the pricing date range derived from the parent customer's specific stop-loss or aggregate stop-loss pricing rules.  <b>Note:</b> This field is enabled only when you select an option from the <b>Price Item</b> field.	Yes
Pricing Start Date	Displays the pricing rule start date.  <b>Note:</b> By default it displays the <b>Policy Start Date</b> .	Not applicable
Pricing End Date	Displays the pricing rule end date.  <b>Note:</b> This field displays date only when you select the date range from <b>Parent Customer's SSL or ASL Pricing Rules</b> .	Not applicable



Field Name	Field Description	Mandatory (Yes or No)
Rate Option	Used to indicate the rate option which you want to use for defining the aggregate stop-loss pricing rule for the price item.  <b>Note:</b> Options appears in this field only when you select an option from the <b>Price Item</b> field.	Yes
Settlement Frequency	Used to indicate the settlement frequency which helps to determine the bill after date. The valid values are: <ul style="list-style-type: none"> <li>• <b>Immediately</b> – The bill after date is not calculated. The aggregate stop-loss billable charge is billed immediately in the next cycle.</li> <li>• <b>Manually (At Required Intervals)</b> – The bill after date specified in the <b>Manual Settlement Date</b> parameter while executing the <b>C1-BCASL</b> batch is stamped on the aggregate stop-loss billable charge.</li> <li>• <b>Monthly</b> – The bill after date specified in the <b>Manual Settlement Date</b> parameter while executing the <b>C1-BCASL</b> batch is stamped on the aggregate stop-loss billable charge.</li> <li>• <b>Yearly</b> – The bill after date in the aggregate stop-loss billable charge is set to the pricing end date.</li> </ul> <b>Note:</b> This field is enabled only when you select an option from the <b>Price Item</b> field.	Yes
Underwriter Review	Used to indicate whether the underwriter settlement review flag is on or off. The valid values are: <ul style="list-style-type: none"> <li>• Yes</li> <li>• No</li> </ul> <b>Note:</b> This field is enabled only when you select an option from the <b>Price Item</b> field.	Yes

5. Enter the required details in the **Main** section.
6. Define accumulation parameters in an aggregate stop-loss pricing rule, if required.

**Note:** The **Accumulation Parameters** section appears only when an option from the **Price Item** field is selected.

7. Define run-in parameters in an aggregate stop-loss pricing rule, if required.

**Note:** The **Run-In Parameters** section appears only when an option from the **Price Item** field is selected.

8. Define characteristics for an aggregate stop-loss pricing rule, if required.

9. Click **Save**.

The aggregate stop-loss pricing rule for a parent customer is defined.

**Related Topics**

For more information on...	See...
<b>Customer 360° Information – Pricing</b> tab	<a href="#">Customer 360° Information - Pricing</a> on page 229
<b>Parent Customer Pricing Rules</b> zone	<a href="#">Parent Customer Pricing Rules</a> on page 231
How to define accumulation parameters in an aggregate stop-loss pricing rule	<a href="#">Defining Accumulation Parameters in an Aggregate Stop-Loss Pricing Rule</a> on page 2434
How to define run-in parameters in an aggregate stop-loss pricing rule	<a href="#">Defining Run-in Parameters in an Aggregate Stop-Loss Pricing Rule</a> on page 2437
How to define characteristics for an aggregate stop-loss pricing rule	<a href="#">Defining Characteristics for an Aggregate Stop-Loss Pricing Rule</a> on page 2438

## Defining Accumulation Parameters in an Aggregate Stop-Loss Pricing Rule

**Procedure**

To define accumulation parameters in an aggregate stop-loss pricing rule:

1. Ensure that the **Accumulation Parameters** section is expanded only when you have selected an option from the **Price Item** field of **Main** section while defining an aggregation stop-loss pricing rule.

The **Accumulation Parameters** section contains the following fields:

Field Name	Field Description	Mandatory (Yes or No)
Accumulation Group ID	Displays blank field, accumulation group ID is generated when accumulation parameter values are defined for an aggregation stop-loss.	Not applicable
ASL Credit Account	Used to indicate the account in which the aggregate stop-loss amount should be credited.  <b>Note:</b> This field becomes read only when you select a date range from the <b>Parent Customer's SSL or ASL Pricing Rules</b> .	Not applicable
Incurred Start Date	Displays the incurred start date based on which you want to accumulate the aggregate stop-loss.  <b>Note:</b> The accumulated aggregated stop-loss for claim transactions are processed in the run-in or active period of the policy. This field displays date only when you select a date range from the <b>Parent Customer's SSL or ASL Pricing Rules</b> . <b>Incurred Start Date</b> is equal to the pricing rule start date.	Not applicable

Field Name	Field Description	Mandatory (Yes or No)
Incurred End Date	<p>Displays the incurred end date based on which you want to accumulate the aggregate stop-loss.</p> <div data-bbox="529 323 1027 699" style="border: 1px solid black; padding: 5px;"> <p><b>Note:</b></p> <p>The accumulated aggregated stop-loss for claim transactions are processed in the run-in or active period of the policy.</p> <p>This field displays date only when you select a date range from the <b>Parent Customer's SSL or ASL Pricing Rules</b>.</p> <p><b>Incurred End Date</b> is equal to the pricing rule end date.</p> </div>	Not applicable
ASL Payout Limit	Used to specify the maximum limit defined for aggregated stop-loss at the member or main subscriber level.	Yes
Paid Start Date	<p>Used to specify the paid start date based on which you want to accumulate the aggregate stop-loss.</p> <div data-bbox="529 951 1027 1323" style="border: 1px solid black; padding: 5px;"> <p><b>Note:</b></p> <p>The accumulated specific stop-loss for claim transactions are processed in the run-in or active period of the policy.</p> <p>This field displays date only when you select a date range from the <b>Parent Customer's SSL or ASL Pricing Rules</b>.</p> <p><b>Paid Start Date</b> is equal to the pricing rule start date.</p> </div>	Yes
Paid End Date	<p>Used to specify the paid end date based on which you want to accumulate the aggregate stop-loss.</p> <div data-bbox="529 1463 1027 1835" style="border: 1px solid black; padding: 5px;"> <p><b>Note:</b></p> <p>The accumulated specific stop-loss for claim transactions are processed in the run-in or active period of the policy.</p> <p>This field displays date only when you select a date range from the <b>Parent Customer's SSL or ASL Pricing Rules</b>.</p> <p><b>Paid End Date</b> is equal to the pricing rule end date.</p> </div>	Yes

Field Name	Field Description	Mandatory (Yes or No)
Settlement Days	Used to indicate the settlement days which helps to calculate the settlement date.  <b>Note:</b> Settlement date is calculated as the pricing end date, incurred end date, or paid end date whichever is later added with the settlement days.	Yes
ASL Limit (During Policy Period)	Used to indicate the aggregate stop-loss limit set during the policy period. The valid values are: <ul style="list-style-type: none"> <li>• Policy Based Limit</li> <li>• Enrollment Based Limit</li> <li>• Percentage of Enrollment Based Limit</li> <li>• Enrollment Based or Minimum ASL Limit (Whichever is Greater)</li> </ul>	Yes
ASL Limit (During Settlement Period)	Used to indicate the aggregate stop-loss limit set during the settlement period. The valid values are: <ul style="list-style-type: none"> <li>• Policy Based Limit</li> <li>• Enrollment Based Limit</li> <li>• Enrollment Based or Minimum ASL Limit (Whichever is Greater)</li> </ul>	Yes
Minimum ASL Limit	Used to specify the minimum ASL limit.  <b>Note:</b> This field is enabled only when you select the <b>Enrollment Based or Minimum ASL Limit (Whichever is Greater)</b> option from the <b>ASL Limit (During Policy Period)</b> or <b>ASL Limit (During Settlement Period)</b> field.	Yes (Conditional)  <b>Note:</b> This field is required when the <b>ASL Limit (During Policy Period)</b> or <b>ASL Limit (During Settlement Period)</b> is <b>Enrollment Based or Minimum ASL Limit (Whichever is Greater)</b> .
Percentage of Enrollment Based Limit	Used to specify the percentage of enrollment based limit.  <b>Note:</b> This field is enabled only when you select the <b>Percentage of Enrollment Based Limit</b> option from <b>ASL Limit (During Policy Period)</b> field.	Yes (Conditional)  <b>Note:</b> This field is required when the <b>ASL Limit (During Policy Period)</b> is <b>Percentage of Enrollment Based Limit</b> .
Policy Based Limit	Used to specify the policy based limit.  <b>Note:</b> This field is enabled only when you select the <b>Policy Based Limit</b> option from the <b>ASL Limit (During Policy Period)</b> or <b>ASL Limit (During Settlement Period)</b> field.	Yes (Conditional)  <b>Note:</b> This field is required when the <b>ASL Limit (During Policy Period)</b> or <b>ASL Limit (During Settlement Period)</b> is <b>Policy Based Limit</b> .

2. Enter the required details in the **Accumulation Parameters** section.

### 3. Click **Save**.

The accumulation parameters are defined in the aggregated stop-loss pricing rule.

#### Related Topics

For more information on...	See...
How to define an aggregated stop-loss pricing rule for a parent customer	<a href="#">Defining an Aggregate Stop-Loss Pricing Rule for a Parent Customer</a> on page 2431
How to edit an aggregated stop-loss pricing rule of a parent customer	<a href="#">Editing an Aggregate Stop-Loss Pricing Rule of a Bill Group</a> on page 2453

## Defining Run-in Parameters in an Aggregate Stop-Loss Pricing Rule

### Prerequisites

To define run-in parameters in an aggregate stop-loss pricing rule, you should have:

- Settlement days defined in the application.
- ASL limit during the policy period defined in the application.
- ASL limit during the settlement period defined in the application.

### Procedure

To define run-in parameters in an aggregate stop-loss pricing rule:

1. Ensure that the **Run-In Parameters** section is expanded only when you have selected an option from the **Price Item** field of **Main** section while defining an aggregate stop-loss pricing rule.

The **Run-In Parameters** section contains the following fields:

Field Name	Field Description	Mandatory (Yes or No)
Run-In	Used to specify whether the run-in parameters of the run-in period of policy are to be considered or not in an aggregate stop-loss pricing	No
Accumulation Group ID	Displays blank column, accumulation group ID is generated when accumulation parameter values are defined for an aggregate stop-loss.	Not applicable
Incurred Start Date	Used to specify the incurred start date based on the run-in period of the policy in the aggregate stop-loss.  <b>Note:</b> This field is enabled only when you select the checkbox for the <b>Run-In</b> field.	Yes
Incurred End Date	Used to specify the incurred end date based on the run-in period of the policy in the aggregate stop-loss.  <b>Note:</b> This field is enabled only when you select the checkbox for the <b>Run-In</b> field.	Yes

Field Name	Field Description	Mandatory (Yes or No)
Paid Start Date	Used to specify the paid start date based on the run-in period of the policy in the aggregate stop-loss.  <b>Note:</b> This field is enabled only when you select the checkbox for the <b>Run-In</b> field.	Yes
Paid End Date	Used to specify the paid end date based on the run-in period of the policy in the aggregate stop-loss.  <b>Note:</b> This field is enabled only when you select the checkbox for the <b>Run-In</b> field.	Yes
Run-In Maximum Limit	Used to specify the maximum limit of the run-in parameters.  <b>Note:</b> This field is enabled only when you select the checkbox for the <b>Run-In</b> field.	Yes

- Enter the required details in the **Run-In Parameters** section.
- Click **Save**.

The run-in parameters are defined in the aggregate stop-loss pricing rule.

#### Related Topics

For more information on...	See...
How to define an aggregate stop-loss pricing rule for a parent customer	<a href="#">Defining an Aggregate Stop-Loss Pricing Rule for a Parent Customer</a> on page 2431
How to edit an aggregate stop-loss pricing rule of a parent customer	<a href="#">Editing an Aggregate Stop-Loss Pricing Rule of a Parent Customer</a> on page 2439

## Defining Characteristics for an Aggregate Stop-Loss Pricing Rule

### Prerequisites

To define characteristics for an aggregate stop-loss pricing rule, you should have:

- Characteristic types defined in the application (where the characteristic entity is set to **Pricing Rule**)

### Procedure

To define characteristics for an aggregate stop-loss pricing rule:

- Ensure that the **Characteristics** section is expanded when you are defining or editing a pricing rule.

The **Characteristics** section contains the following columns in a grid:

Column Name	Column Description	Mandatory (Yes or No)
Effective Date	Used to specify the date from when the characteristic is effective for the aggregate stop-loss pricing rule.	Yes (Conditional)  <b>Note:</b> This field is required when you are defining a characteristic for the aggregate stop-loss pricing rule.

Column Name	Column Description	Mandatory (Yes or No)
Characteristic Type	Used to indicate the characteristic type.  <b>Note:</b> The list includes only those characteristic types where the characteristic entity is set to <b>Pricing Rule</b> .	Yes (Conditional)  <b>Note:</b> This field is required when you are defining a characteristic for the aggregate stop-loss pricing rule.
Characteristic Value	Used to specify the value for the characteristic type.  <b>Note:</b> If you select a predefined characteristic type, the <b>Search</b>  icon appears corresponding to the <b>Characteristic Value</b> field. On clicking the <b>Search</b> icon, the <b>Predefined Characteristic Search</b> window appears.  On specifying the value for a predefined characteristic type, the description of the characteristic value appears corresponding to the <b>Characteristic Value</b> field.	Yes (Conditional)  <b>Note:</b> This field is required when you are defining a characteristic for the aggregate stop-loss pricing rule.

- Enter the required details in the **Characteristics** section.
- If you want to define more than one characteristic for the aggregate stop-loss pricing rule, click the **Add**  icon and then repeat step 2.

**Note:** However, if you want to remove a characteristic from the aggregate stop-loss pricing rule, click the **Delete**  icon corresponding to the characteristic.

- Click **Save**.

The characteristics are defined for the aggregate stop-loss pricing rule.

### Related Topics

For more information on...	See...
How to define an aggregate stop-loss pricing rule for a parent customer	<a href="#">Defining an Aggregate Stop-Loss Pricing Rule for a Parent Customer</a> on page 2431
How to edit the aggregate stop-loss pricing rule for a parent customer	<a href="#">Editing an Aggregate Stop-Loss Pricing Rule of a Parent Customer</a> on page 2439

## Editing an Aggregate Stop-Loss Pricing Rule of a Parent Customer

### Prerequisites

To edit an aggregate stop-loss pricing rule of a parent customer, you should have:

- Business Object **C1-PricingRuleASL** defined for aggregate stop-loss pricing rule.
- SSL accumulation level defined in the application.
- Underwriter review defined in the application.

### Procedure

To edit an aggregate stop-loss pricing rule of a parent customer:

1. Search for the account, person, or policy whose pricing details you want to view in the **Customer 360° View** screen.
2. In the **Search Results** section, click the **View** () icon corresponding to the account, person, or policy whose pricing details you want to view.

The **Account, Person, or Policy** tab in the **Customer 360° Information** screen appears.

3. Click the **Pricing** tab, in the **Parent Customer Pricing Rules** zone click the **Edit** () icon in the **Edit** column corresponding to the pricing rule type for aggregate stop-loss whose aggregate stop-loss pricing rule details you v

The **Aggregate Stop-Loss (ASL) Pricing Rule** screen appears. It contains the following sections:

- **Customer Information** – Displays the customer information.
- **Main** – Used to specify basic details about the aggregate stop-loss pricing rule.
- **Accumulation Parameters** – Used to define the accumulation parameters based on which you want to accumulate the aggregate stop-loss for the transactions which are processed in the run-in or active period of the policy.
- **Run-In Parameters** – Used to define run-in parameters in the run-in period of the policy.
- **Characteristics** – Used to define the characteristics for an aggregate stop-loss pricing rule.

The **Customer Information** section contains the following fields:

Field Name	Field Description	Mandatory (Yes or No)
Parent Customer Information	Displays the parent customer information	Not applicable
Pricing Rule Type	Indicates the pricing rule type.	Not applicable

The **Main** section contains the following fields:

Field Name	Field Description	Mandatory (Yes or No)
Price Item	Indicates the price item defined for pricing.	Not applicable
Parent Customer's SSL or ASL Pricing Rules	Indicates the pricing date range derived from the parent customer's specific stop-loss or aggregate stop-loss pricing rules.	Not applicable
Pricing Start Date	Displays the pricing rule start date.	Not applicable
Pricing End Date	Displays the pricing rule end date.	Not applicable
Rate Option	Indicates the rate option used for defining the aggregate stop-loss pricing rule for the price item.	Not applicable



Field Name	Field Description	Mandatory (Yes or No)
Settlement Frequency	<p>Indicates the settlement frequency to determine the bill after date. The valid values are:</p> <ul style="list-style-type: none"> <li>• <b>Immediately</b> – The bill after date is not calculated. The aggregate stop-loss billable charge is billed immediately in the next cycle.</li> <li>• <b>Manually (At Required Intervals)</b> – The bill after date specified in the <b>Manual Settlement Bill After Date</b> parameter while executing the <b>C1-BCASL</b> batch is stamped on the aggregate stop-loss billable charge.</li> <li>• <b>Monthly</b> – The bill after date specified in the <b>Manual Settlement Date</b> parameter while executing the <b>C1-BCASL</b> batch is stamped on the aggregate stop-loss billable charge.</li> <li>• <b>Yearly</b> – The bill after date in the aggregate stop-loss billable charge is set to the pricing end date.</li> </ul>	Yes
Underwriter Review	<p>Used to indicate whether the underwriter settlement review flag is on or off. The valid values are:</p> <ul style="list-style-type: none"> <li>• Yes</li> <li>• No</li> </ul>	Yes

4. Modify the details in the **Main** section, if required.
5. Modify the accumulation parameters in an aggregate stop-loss pricing rule, if required.
6. Modify the run-in parameters in an aggregate stop-loss pricing rule, if required.
7. Add, edit, or remove characteristics for the aggregate stop-loss pricing rule, if required.
8. Click **Save**.

The changes made to an aggregate stop-loss pricing rule for a parent customer are saved.

### **Related Topics**

For more information on...	See...
<b>Customer 360° Information – Pricing</b> tab	<a href="#">Customer 360° Information - Pricing</a> on page 229
<b>Parent Customer Pricing Rules</b> zone	<a href="#">Parent Customer Pricing Rules</a> on page 231
How to define accumulation parameters in an aggregate stop-loss pricing rule	<a href="#">Defining Accumulation Parameters in an Aggregate Stop-Loss Pricing Rule</a> on page 2434
How to define run-in parameters in an aggregate stop-loss pricing rule	<a href="#">Defining Run-in Parameters in an Aggregate Stop-Loss Pricing Rule</a> on page 2437
How to define characteristics for an aggregate stop-loss pricing rule	<a href="#">Defining Characteristics for an Aggregate Stop-Loss Pricing Rule</a> on page 2438

## Viewing an Aggregate Stop-Loss Pricing Rule of a Parent Customer

### Procedure

To view an aggregate stop-loss pricing rule of a parent customer:

1. Search for the account, person, or policy whose pricing details you want to view in the **Customer 360° View** screen.
2. In the **Search Results** section, click the **View** () icon corresponding to the account, person, or policy whose pricing details you want to view.  
The **Account, Person, or Policy** tab in the **Customer 360° Information** screen appears.
3. Click the **Pricing** tab.
4. In the **Parent Customer Pricing Rules** zone, click the link in the **Pricing Rule Information** column corresponding to the aggregate stop-loss pricing rule type whose aggregate stop-loss pricing rule parent customer details you want to view.

The **Pricing Rule** screen appears. It contains the following zone:

- **Aggregate Stop-Loss** – Displays the pricing rule aggregate stop-loss details for a parent customer. It contains the following sections:
  - **Main** – Displays the basic details about the aggregate stop-loss pricing rule.
  - **Accumulation Parameters** – Displays the accumulation parameters based on which accumulated aggregate stop-loss for the transactions are processed in the run-in or active period of the policy.
  - **Run-In Parameters** – Displays the run-in parameters in the run-in period of the policy.
  - **Characteristics** – Displays the characteristics defined for the aggregate stop-loss pricing rule.
- 5. View the basic details of aggregate stop-loss pricing rule in the **Main** zone.
- 6. View the accumulated parameters in the **Accumulation Parameters** zone.
- 7. View the run-in parameters in the **Run-In Parameters** zone.
- 8. View the characteristics defined for the aggregate stop-loss pricing rule in the **Characteristics** zone.

### Related Topics

For more information on...	See...
<b>Customer 360° Information – Pricing</b> tab	<a href="#">Customer 360° Information - Pricing</a> on page 229
<b>Parent Customer Pricing Rules</b> zone	<a href="#">Parent Customer Pricing Rules</a> on page 231
<b>Pricing Rule</b> screen	<a href="#">Pricing Rule (Used for Viewing)</a> on page 2688
<b>Aggregate Stop-Loss</b> zone	<a href="#">Aggregate Stop-Loss</a> on page 2691

## Deleting an Aggregate Stop-Loss Pricing Rule of a Parent Customer

### Procedure

To delete an aggregate stop-loss pricing rule of a parent customer:

1. Search for the account, person, or policy whose pricing details you want to view in the **Customer 360° View** screen.
2. In the **Search Results** section, click the **View** () icon corresponding to the account, person, or policy whose pricing details you want to view.

The **Account, Person, or Policy** tab in the **Customer 360° Information** screen appears.

3. Click the **Pricing** tab, in the **Parent Customer Pricing Rules** zone, click the **Delete** () icon in the **Delete** column corresponding to the aggregate stop-loss pricing rule type whose aggregate stop-loss pricing rule you want to delete. A message appears confirming whether you want to delete the aggregate stop-loss pricing rule.
4. Click **OK**.

The aggregate stop-loss pricing rule is deleted.

### Related Topics

For more information on...	See...
<b>Customer 360° Information – Pricing</b> tab	<a href="#">Customer 360° Information - Pricing</a> on page 229
<b>Parent Customer Pricing Rules</b> zone	<a href="#">Parent Customer Pricing Rules</a> on page 231

## Defining an Aggregate Stop-Loss Pricing Rule for a Bill Group

### Prerequisites

To define an aggregate stop-loss pricing rule for a bill group, you should have:

- Business Object **C1-PricingRule** defined for pricing rule.
- Business Object **C1-PricingRuleASL** defined for aggregate stop-loss pricing rule.
- Pricing rule type defined in the application.
- Policy status defined in the application.
- Price item defined in the application.
- Rate option defined in the application.

### Procedure

To define an aggregate stop-loss pricing rule for a bill group:

1. Search for the account, person, or policy whose pricing details you want to view in the **Customer 360° View** screen.
2. In the **Search Results** section, click the **View** () icon corresponding to the account, person, or policy whose pricing details you want to view.

The **Account, Person, or Policy** tab in the **Customer 360° Information** screen appears.

3. Click the **Pricing** tab and then click the **Add** link in the upper right corner of the **Bill Group ASO Policy Pricing Rules** zone.

The **Pricing Rule** screen appears. It contains the following fields:

Field Name	Field Description	Mandatory (Yes or No)
Person Name	Displays the person name.	Not applicable
Person Type	Displays the person type.	Not applicable

Field Name	Field Description	Mandatory (Yes or No)
Pricing Rule Type	Used to indicate the pricing rule type to create the pricing rule.  <b>Note:</b> You can create an aggregate stop-loss pricing rule using the <b>Pricing Rule Type</b> for aggregate stop-loss.	Yes
Pricing Group	Used to indicate the pricing group.	No
Policy Status	Used to indicate the policy status for pricing rule. The valid values are: <ul style="list-style-type: none"> <li>In Force/Active</li> <li>Post Runout</li> <li>Runout</li> </ul> <b>Note:</b> Aggregate stop-loss pricing rule cannot be created for <b>Runout</b> or <b>Post Runout</b> policy status where the policy run out end date is missing.	Yes

#### 4. Click **OK**.

The **Aggregate Stop-Loss (ASL) Pricing Rule** screen appears. It contains the following sections:

- **Customer Information** – Displays the customer information for bill group.
- **Main** – Used to specify basic details about the aggregate stop-loss pricing rule.
- **Accumulation Criteria** – Used to define the accumulation criteria in an aggregate stop-loss pricing rule.
- **Pricing Information** – Used to define stop-loss eligibility for claim line items.
- **Characteristics** – Used to define the characteristics for the aggregate stop-loss pricing rule.

The **Customer Information** section contains the following fields:

Field Name	Field Description	Mandatory (Yes or No)
Bill Group Information	Displays the bill group information.	Not applicable
Policy Start Date	Displays the policy start date.	Not applicable
Policy End Date	Displays the policy end date.	Not applicable
Policy Status	Indicates the policy status for pricing rule. The valid values are: <ul style="list-style-type: none"> <li>In Force/Active</li> <li>Post Runout</li> <li>Runout</li> </ul>	Not applicable
Pricing Rule Type	Indicates the pricing rule type.	Not applicable

The **Main** section contains the following fields:

Field Name	Field Description	Mandatory (Yes or No)
Price Item	Used to indicate the price item.  <b>Note:</b> Once an option is selected for this field, the field appears disabled.	Yes
Parent Customer's SSL or ASL Pricing Rules	Used to indicate the pricing date range derived from the parent customer's specific stop-loss or aggregate stop-loss pricing rule.  <b>Note:</b> This field is enabled for selection when an option from <b>Price Item</b> field is selected.	Yes
Pricing Start Date	Displays the pricing rule start date.  <b>Note:</b> This field displays the <b>Policy Start Date</b> .	Not applicable
Pricing End Date	Displays the pricing rule end date.  <b>Note:</b> This field displays the <b>Policy End Date</b> .	Not applicable
Rate Option	Used to indicate the rate option to define the aggregate stop-loss pricing rule for the price item.  <b>Note:</b> Rate options in this field appears for selection, only when you select an option from the <b>Price Item</b> field.	Yes

- Enter the required details in the **Main** section.
- Define accumulation criteria in an aggregate stop-loss pricing rule, if required.

**Note:**  
The **Accumulation Criteria** section appears only when an option from **Parent Customer's SSL or ASL Pricing Rules** field is selected.  
You can also define the **Accumulation Criteria** for each rule in an aggregate stop-loss pricing rule.

- Define stop-loss eligibility for claim line items, if required.

**Note:**  
The **Pricing Information** section appears only when an option from **Parent Customer's SSL or ASL Pricing Rules** field is selected.  
You can also define the **Pricing Information** for each rule in an aggregate stop-loss pricing rule.

- Define characteristics for an aggregate stop-loss pricing rule, if required.
- Click **Save**.

The aggregate stop-loss pricing rule for a bill group is defined.

**Note:** A price list and price assignment is created, the price list created is assigned to the aggregate stop-loss pricing rule.

**Related Topics**

For more information on...	See...
<b>Customer 360° Information – Pricing</b> tab	<a href="#">Customer 360° Information - Pricing</a> on page 229
<b>Bill Group ASO Policy Pricing Rules</b> zone	<a href="#">Bill Group ASO Policy Pricing Rules</a> on page 237
How to define accumulation criteria in an aggregate stop-loss pricing rule	<a href="#">Defining Accumulation Criteria in an Aggregate Stop-Loss Pricing Rule</a> on page 2446
How to define stop-loss eligibility for claim line items	<a href="#">Defining Claim Pricing Rules in an Aggregate Stop-Loss Pricing Rule</a> on page 2448
How to define characteristics for an aggregate stop-loss pricing rule	<a href="#">Defining Characteristics for an Aggregate Stop-Loss Pricing Rule</a> on page 2438







**Defining Accumulation Criteria in an Aggregate Stop-Loss Pricing Rule****Procedure**

To define accumulation criteria in an aggregate stop-loss pricing rule:

1. Ensure that the **Accumulation Criteria** section is expanded only when you have selected an option from the **Parent Customer’s SSL or ASL Pricing Rules** field of **Main** section while defining or editing an aggregate stop-loss pricing rule.

The **Accumulation Criteria** section contains the following fields:

Field Name	Field Description	Mandatory (Yes or No)
Accumulation Group ID	Displays blank field, accumulation group ID is generated when accumulation criteria values are defined for an aggregate stop-loss.	Not applicable
Price Item	Used to specify the price item information.  <b>Note:</b> On clicking the <b>Search</b>  icon that appears corresponding to the <b>Price Item</b> field, the <b>Price Item Search</b> window appears.	No

Field Name	Field Description	Mandatory (Yes or No)									
Price Item Parameters	This field contains the following columns:	No									
	<table border="1"> <thead> <tr> <th>Column Name</th> <th>Column Description</th> <th>Mandatory (Yes or No)</th> </tr> </thead> <tbody> <tr> <td>Price Item Parameter</td> <td>Used to specify multiple parameters based on which you want to determine the price item utilization.   <div style="border: 1px solid black; padding: 5px;"> <b>Note:</b> On clicking the <b>Search</b>  icon that appears corresponding to the <b>Price Item Parameter</b> field, the <b>Price Item Parameter Search</b> window appears. </div> </td> <td>No</td> </tr> <tr> <td>Parameter Value</td> <td>Used to specify the value of the parameter.   <div style="border: 1px solid black; padding: 5px;"> <b>Note:</b> On selecting the <b>Price Item Parameter</b>, the <b>Search</b>  icon appears corresponding to this field, and on clicking the icon, the <b>Parameter Value Search</b> window appears. </div> </td> <td>No</td> </tr> </tbody> </table>		Column Name	Column Description	Mandatory (Yes or No)	Price Item Parameter	Used to specify multiple parameters based on which you want to determine the price item utilization.  <div style="border: 1px solid black; padding: 5px;"> <b>Note:</b> On clicking the <b>Search</b>  icon that appears corresponding to the <b>Price Item Parameter</b> field, the <b>Price Item Parameter Search</b> window appears. </div>	No	Parameter Value	Used to specify the value of the parameter.  <div style="border: 1px solid black; padding: 5px;"> <b>Note:</b> On selecting the <b>Price Item Parameter</b>, the <b>Search</b>  icon appears corresponding to this field, and on clicking the icon, the <b>Parameter Value Search</b> window appears. </div>	No
	Column Name		Column Description	Mandatory (Yes or No)							
Price Item Parameter	Used to specify multiple parameters based on which you want to determine the price item utilization.  <div style="border: 1px solid black; padding: 5px;"> <b>Note:</b> On clicking the <b>Search</b>  icon that appears corresponding to the <b>Price Item Parameter</b> field, the <b>Price Item Parameter Search</b> window appears. </div>	No									
Parameter Value	Used to specify the value of the parameter.  <div style="border: 1px solid black; padding: 5px;"> <b>Note:</b> On selecting the <b>Price Item Parameter</b>, the <b>Search</b>  icon appears corresponding to this field, and on clicking the icon, the <b>Parameter Value Search</b> window appears. </div>	No									

2. Enter the required details in the **Accumulation Criteria** section.
3. If you want to define more than one price item in the accumulation group, click the **Add**  icon and then repeat step 2.

**Note:** However, if you want to remove a price item from the accumulation group, click the **Delete**  icon corresponding to the price item.

4. If you want to define more than one price item parameters for the price item, click the **Add**  icon and then repeat step 2.

**Note:** However, if you want to remove a price item parameter from the price item, click the **Delete** (🗑️) icon corresponding to the price item parameter.

5. Click **Save**.

The accumulation criteria is defined in the aggregate stop-loss pricing rule.

6. You can define accumulation rules for each rule in an aggregate stop-loss pricing rule.

**Note:** You can exclude a rule from the aggregate stop-loss pricing by selecting the **Exclude Rule** checkbox.

### Related Topics

For more information on...	See...
How to define an aggregate stop-loss pricing rule for a bill group	<a href="#">Defining an Aggregate Stop-Loss Pricing Rule for a Bill Group</a> on page 2443
How to edit an aggregate stop-loss pricing rule of a bill group	<a href="#">Editing an Aggregate Stop-Loss Pricing Rule of a Bill Group</a> on page 2453

## Defining Claim Pricing Rules in an Aggregate Stop-Loss Pricing Rule

### Procedure

To define claim pricing rules in an aggregate stop-loss pricing rule:

1. Ensure that the **Pricing Information** section is expanded only when you have selected an option from the **Parent Customer's SSL or ASL Pricing Rules** field of **Main** section while defining or editing an aggregate stop-loss pricing rule.

The **Pricing Information** section contains the following section:

- **Claim Pricing Rule** – Used to indicate the claim pricing rule. It contains the following sub-sections:
  - **Domestic Provider Claims** – Used to specify the domestic provider claim while calculating aggregate stop-loss.
  - **Markup or Markdown Values** – Used to define the markup or markdown values for billable charge line.
  - **Line Items** – Used to associate line items eligible for billing.

The **Claim Pricing Rule** section contains the following field:

Field Name	Field Description	Mandatory (Yes or No)
Effective Claim Pricing Rule	Used to indicate the claim pricing rule effective for pricing.	No

On clicking the **Reapply Claim Template** button to the right side of the **Effective Claim Pricing Rule** field you can reapply for claim pricing rule.

**Note:** The **Reapply Claim Template** button appears only when you are editing an aggregate stop-loss.

The **Domestic Provider Claims** section contains the following field:



Field Name	Field Description	Mandatory (Yes or No)
Exclude ASL (Percentage)	Used to specify the domestic provider claim billable charge line excluding the aggregate stop-loss in percentage to create domestic provider claim calculation lines.	No

The **Markup or Markdown Values** section contains the following fields:

Field Name	Field Description	Mandatory (Yes or No)
Pricing Strategy	Indicates the pricing strategy. The valid values are: <ul style="list-style-type: none"> <li>• Markdown</li> <li>• Markup</li> <li>• None</li> </ul>	Not applicable
Markup or Markdown Type	Indicates the markup or markdown value type for claim line items. The valid values are: <ul style="list-style-type: none"> <li>• Flat Amount</li> <li>• Percentage</li> </ul>	Not applicable
Markup or Markdown Amount	Displays the markup or markdown amount. <div style="border: 1px solid black; padding: 2px; margin-top: 5px;"> <p><b>Note:</b> This field displays amount when <b>Markup or Markdown Type</b> field is <b>Flat Amount</b>.</p> </div>	Not applicable

The **Line Items** section contains the following fields:

Field Name	Field Description	Mandatory (Yes or No)
Sequence	Displays the sequence number for the line items.	Not applicable
Line Item	Displays the billing line items.	Not applicable
Eligible for Specific Stop-Loss	Used to specify whether the line item is eligible or not eligible for aggregate stop-loss.	No
Markup or Markdown Percentage Eligibility	Displays whether the line item is eligible or not eligible for markup or markdown percentage. The valid values are: <ul style="list-style-type: none"> <li>• Eligible</li> <li>• Not Eligible</li> </ul>	Not applicable
Markup or Markdown Percentage	Displays the percentage for markup or markdown value.	Not applicable

2. Select the required details in the **Claim Pricing Rule** section, if required.
3. Enter the required details in the **Domestic Provider Claims** section, if required.
4. Select the required details in the **Line Items** section, if required.

5. Click **Save**.

The claim line items are defined in the aggregate stop-loss pricing rule.

## 6. You can define eligibility claim line items for each rule in an aggregate stop-loss pricing rule.

**Note:** You can exclude a rule from the aggregate stop-loss pricing by selecting the **Exclude Rule** checkbox.

**Related Topics**

For more information on...	See...
How to define an aggregate stop-loss pricing rule for a bill group	<a href="#">Defining an Aggregate Stop-Loss Pricing Rule for a Bill Group</a> on page 2443
How to edit an aggregate stop-loss pricing rule of a bill group	<a href="#">Editing an Aggregate Stop-Loss Pricing Rule of a Bill Group</a> on page 2453

**Defining an Aggregate Stop-Loss Pricing Rule for a Bill Group Using a Pricing Group****Prerequisites**

To define an aggregate stop-loss pricing rule for a bill group using a pricing group, you should have:

- Business Object **C1-PricingRule** defined for pricing rule.
- Business Object **C1-PricingRuleASL** defined for aggregate stop-loss pricing rule.
- Pricing rule type defined in the application.
- Pricing group defined in the application.
- Policy status defined in the application.
- Price item defined in the application.
- Rate option defined in the application.

**Procedure**

To define an aggregate stop-loss pricing rule for a bill group using a pricing group:

1. Search for the account, person, or policy whose pricing details you want to view in the **Customer 360° View** screen.
2. In the **Search Results** section, click the **View** () icon corresponding to the account, person, or policy whose pricing details you want to view.  
The **Account**, **Person**, or **Policy** tab in the **Customer 360° Information** screen appears.
3. Click the **Pricing** tab and then click the **Add** link in the upper right corner of the **Bill Group ASO Policy Pricing Rules** zone.

The **Pricing Rule** screen appears. It contains the following fields:

Field Name	Field Description	Mandatory (Yes or No)
Person Name	Displays the person name.	Not applicable
Person Type	Displays the person type.	Not applicable

Field Name	Field Description	Mandatory (Yes or No)
Pricing Rule Type	Used to indicate the pricing rule type to create the pricing rule.  <b>Note:</b> You can create an aggregate stop-loss pricing rule using the <b>Pricing Rule Type</b> for aggregate stop-loss.	Yes
Pricing Group	Used to indicate the pricing group.	Yes
Policy Status	Used to indicate the policy status for pricing rule. The valid values are: <ul style="list-style-type: none"> <li>• In Force/Active</li> <li>• Post Runout</li> <li>• Runout</li> </ul> <b>Note:</b> Aggregate stop-loss pricing rule cannot be created for <b>Runout</b> or <b>Post Runout</b> policy status where the policy run out End Date is missing.	Yes

#### 4. Click **OK**.

The **Aggregate Stop-Loss (ASL) Pricing Rule** screen appears. It contains the following sections:

- **Customer Information** – Displays the customer information for bill group using pricing group.
- **Main** – Used to specify basic details about the claim pricing rule.
- **Markup or Markdown Values** – Used to define the markup or markdown values for billable charge line for each rule.
- **Line Items** – Used to associate line items eligible for billing for each rule.
- **Characteristics** – Used to define the characteristics for the claim pricing rule.

The **Customer Information** section contains the following fields:

Field Name	Field Description	Mandatory (Yes or No)
Bill Group Information	Displays the bill group information.	Not applicable
Policy Start Date	Displays the policy start date.	Not applicable
Policy End Date	Displays the policy end date.	Not applicable
Policy Status	Indicates the policy status for pricing rule. The valid values are: <ul style="list-style-type: none"> <li>• In Force/Active</li> <li>• Post Runout</li> <li>• Runout</li> </ul>	Not applicable
Pricing Group	Displays the pricing group.	Not applicable
Pricing Rule Type	Indicates the pricing rule type.	Not applicable

The **Main** section contains the following fields:

Field Name	Field Description	Mandatory (Yes or No)
Price Item	Used to indicate the price item.  <b>Note:</b> Once an option is selected for this field, the field appears disabled.	Yes
Parent Customer's SSL or ASL Pricing Rules	Used to indicate the pricing date range derived from the parent customer's specific stop-loss or aggregate stop-loss pricing rule.  <b>Note:</b> This field is enabled for selection when an option from <b>Price Item</b> field is selected.	Yes
Pricing Start Date	Displays the pricing rule start date.	Yes
Pricing End Date	Displays the pricing rule end date.	Yes
Rate Option	Used to indicate the rate option to define the aggregate stop-loss pricing rule for the price item.  <b>Note:</b> Rate options in this field appears for selection, only when you select an option from the <b>Price Item</b> field.	Yes

- Enter the required details in the **Main** section.
- Define accumulation criteria for each rule in an aggregate stop-loss pricing rule pricing rule, if required.

**Note:** The **Accumulation Criteria** section appears in the rule section and the rule section appears only when an option from **Parent Customer's SSL or ASL Pricing Rules** field is selected.

- Define stop-loss eligibility for claim line items, if required.

**Note:** The **Pricing Information** section appears in the rule section and the rule section appears only when an option from **Parent Customer's SSL or ASL Pricing Rules** field is selected.

- Define characteristics for an aggregate stop-loss pricing rule, if required.
- Click **Save**.

The aggregate stop-loss pricing rule for a bill group using a pricing group is defined.

**Note:** A price list and price assignment is created, the price list created is assigned to the aggregate stop-loss pricing rule.

### Related Topics

For more information on...	See...
<b>Customer 360° Information – Pricing</b> tab	<a href="#">Customer 360° Information - Pricing</a> on page 229
<b>Bill Group ASO Policy Pricing Rules</b> zone	<a href="#">Bill Group ASO Policy Pricing Rules</a> on page 237
How to define Accumulation Criteria in an aggregate stop-loss pricing rule	<a href="#">Defining Accumulation Criteria in an Aggregate Stop-Loss Pricing Rule</a> on page 2446
How to define stop-loss eligibility for claim line items	<a href="#">Defining Claim Pricing Rules in an Aggregate Stop-Loss Pricing Rule</a> on page 2448

For more information on...	See...
How to define characteristics for an aggregate stop-loss pricing rule	<a href="#">Defining Characteristics for an Aggregate Stop-Loss Pricing Rule</a> on page 2438

## Editing an Aggregate Stop-Loss Pricing Rule of a Bill Group

### Prerequisites

To edit an aggregate stop-loss pricing rule of a bill group, you should have:

- Business Object **C1-PricingRuleASL** defined for aggregate stop-loss pricing rule.

### Procedure

To edit an aggregate stop-loss pricing rule of a bill group:

1. Search for the account, person, or policy whose pricing details you want to view in the **Customer 360° View** screen.

2. In the **Search Results** section, click the

**View** () icon corresponding to the account, person, or policy whose pricing details you want to view.

The **Account, Person, or Policy** tab in the **Customer 360° Information** screen appears.

3. Click the **Pricing** tab, in the **Bill Group ASO Policy Pricing Rules** zone click the **Edit** () icon in the **Edit** column corresponding to the pricing rule type for aggregate stop-loss whose aggregate stop-loss pricing rule details you want to view.

The **Aggregate Stop-Loss (ASL) Pricing Rule** screen appears. It contains the following sections:

- **Customer Information** – Displays the customer information for bill group.
- **Main** – Displays the basic details about the aggregate stop-loss pricing rule.
- **Accumulation Criteria** – Used to define the accumulation criteria in an aggregate stop-loss pricing rule.
- **Pricing Information** – Used to define stop-loss eligibility for claim line items.
- **Characteristics** – Used to define the characteristics for the aggregate stop-loss pricing rule.

The **Customer Information** section contains the following fields:

Field Name	Field Description	Mandatory (Yes or No)
Bill Group Information	Displays the bill group information.	Not applicable
Policy Start Date	Displays the policy start date.	Not applicable
Policy End Date	Displays the policy end date.	Not applicable
Policy Status	Indicates the policy status for pricing rule. The valid values are: <ul style="list-style-type: none"> <li>• In Force/Active</li> <li>• Post Runout</li> <li>• Runout</li> </ul>	Not applicable
Pricing Rule Type	Indicates the pricing rule type.	Not applicable

The **Main** section contains the following fields:

Field Name	Field Description	Mandatory (Yes or No)
Price Item	Indicates the price item.	Not applicable

Field Name	Field Description	Mandatory (Yes or No)
Parent Customer's SSL or ASL Pricing Rules	Indicates the pricing date range derived from the parent customer's specific stop-loss or aggregate stop-loss pricing rule.	Not applicable
Pricing Start Date	Displays the pricing rule start date.	Not applicable
Pricing End Date	Displays the pricing rule end date.	Not applicable
Rate Option	Indicates the rate option of the aggregate stop-loss pricing rule for the price item.	Not applicable

- Modify the accumulation criteria in an aggregate stop-loss pricing rule, if required.

**Note:** You can add, edit, or remove price item and its price item parameters in the accumulation criteria for an aggregate stop-loss, if required.

- Modify the stop-loss eligibility for claim line items, if required.

**Note:** This section also consists of a button, **Reapply Claim Template**, on clicking the button a message occurs indicating that updating the claim template will reset all the default fields on the claim pricing rule.

- Add, edit, or remove characteristics for an aggregate stop-loss pricing rule, if required.
- Click **Save**.

The changes made to an aggregate stop-loss pricing rule for a bill group are saved.

### Related Topics

For more information on...	See...
<b>Customer 360° Information – Pricing</b> tab	<a href="#">Customer 360° Information - Pricing</a> on page 229
<b>Bill Group ASO Policy Pricing Rules</b> zone	<a href="#">Bill Group ASO Policy Pricing Rules</a> on page 237
How to define accumulation criteria in an aggregate stop-loss pricing rule	<a href="#">Defining Accumulation Criteria in an Aggregate Stop-Loss Pricing Rule</a> on page 2446
How to define stop-loss eligibility for claim line items	<a href="#">Defining Claim Pricing Rules in an Aggregate Stop-Loss Pricing Rule</a> on page 2448
How to define characteristics for an aggregate stop-loss pricing rule	<a href="#">Defining Characteristics for an Aggregate Stop-Loss Pricing Rule</a> on page 2438

## Viewing an Aggregate Stop-Loss Pricing Rule of a Bill Group

### Procedure

To view an aggregate stop-loss pricing rule of a bill group:

- Search for the account, person, or policy whose pricing details you want to view in the **Customer 360° View** screen.
- In the **Search Results** section, click the **View** () icon corresponding to the account, person, or policy whose pricing details you want to view.

The **Account**, **Person**, or **Policy** tab in the **Customer 360° Information** screen appears.

- Click the **Pricing** tab.

4. In the **Bill Group ASO Policy Information** zone, click the

**Broadcast** () icon corresponding to the bill group whose aggregate stop-loss pricing rule bill group details you want to view.

5. In the **Bill Group ASO Policy Pricing Rules** zone, click the link in the **Pricing Rule Information** column corresponding to the aggregate stop-loss pricing rule type whose aggregate stop-loss pricing rule bill group you want to view.

The **Pricing Rule** screen appears. It contains the following zone:

- **Aggregate Stop-Loss** – Displays the pricing rule aggregate stop-loss details for a bill group. It contains the following sections:
  - **Main** – Displays the basic details about the aggregate stop-loss pricing rule.
  - **Accumulation Criteria** – Displays the accumulation criteria in an aggregate stop-loss pricing rule.
  - **Pricing Information** – Displays the stop-loss eligibility for claim line items.
  - **Characteristics** – Displays the characteristics defined for the aggregate stop-loss pricing rule.
- 6. View the basic details of aggregate stop-loss pricing rule in the **Main** section.
- 7. View the accumulated criteria in the **Accumulation Criteria** section.
- 8. View the stop-loss eligibility for claim line items in the **Pricing Information** section.
- 9. View the characteristics defined for the aggregate stop-loss pricing rule in the **Characteristics** section.



#### Related Topics

For more information on...	See...
<b>Customer 360° Information – Pricing</b> tab	<a href="#">Customer 360° Information - Pricing</a> on page 229
<b>Bill Group ASO Policy Pricing Rules</b> zone	<a href="#">Bill Group ASO Policy Pricing Rules</a> on page 237
<b>Pricing Rule</b> screen	<a href="#">Pricing Rule (Used for Viewing)</a> on page 2688
<b>Aggregate Stop-Loss</b> zone	<a href="#">Aggregate Stop-Loss</a> on page 2691

## Deleting an Aggregate Stop-Loss Pricing Rule of a Bill Group

### Procedure

To delete an aggregate stop-loss pricing rule of a bill group:

1. Search for the account, person, or policy whose pricing details you want to view in the **Customer 360° View** screen.
2. In the **Search Results** section, click the **View** () icon corresponding to the account, person, or policy whose pricing details you want to view.  
The **Account, Person, or Policy** tab in the **Customer 360° Information** screen appears.
3. Click the **Pricing** tab, in the **Bill Group ASO Policy Pricing Rules** zone, click the **Delete** () icon in the **Delete** column corresponding to the aggregate stop-loss pricing rule type whose aggregate stop-loss pricing rule you want to delete.  
A message appears confirming whether you want to delete the aggregate stop-loss pricing rule.
4. Click **OK**.  
The aggregate stop-loss pricing rule is deleted.

### Related Topics

For more information on...	See...
<b>Customer 360° Information – Pricing</b> tab	<a href="#">Customer 360° Information - Pricing</a> on page 229
<b>Bill Group ASO Policy Pricing Rules</b> zone	<a href="#">Bill Group ASO Policy Pricing Rules</a> on page 237

## Retention Type Claim Based Pricing

The ASO service provider provides claim administrative services and pays the claim amount on behalf of the employer. Different charges, such as administration fees, network fees, managed care fees, are typically charged as retention type claim based fees. The system enables you to charge a flat or percentage based retention type claim based fee. The rate schedule defined in the respective rate option indicates whether the retention type claim based fee is a flat fee or percentage based fee. The system considers the claim line items for calculating the percentage based retention type claim based fee only when the **Retention Claim Based Percentage Calculation** field is set to **Yes**.

You can define a retention type claim based pricing rule at the parent customer and bill group levels. The retention type claim based pricing rule at the bill group level takes precedence over the retention type claim based pricing rule at the parent customer level. You can define retention type claim based pricing rules for parent customers and bill groups from the **Customer 360° Information** screen. You can define a retention type claim based pricing rule using a retention type claim based pricing rule type. It is the retention type claim based pricing rule type which helps the system to determine:

- Business object using which the retention type claim based pricing rule should be created in the system.
- Algorithm which should be triggered while validating a transaction.

**Note:** An algorithm type for validating a transaction is not shipped from the product. You need to create a custom algorithm type, if required.

- Algorithms which should be triggered while deriving account and price item for a transaction.

**Note:** You must create an algorithm using the **C1\_ACCPRIDRV** algorithm type and attach it to the **Account and Price Item Derivation** system event. The **C1\_BAFTDRV** algorithm sets the bill after date to the end date of the aggregation schedule which is specified in the respective rate option. For example, if the aggregation schedule is monthly, the bill after date is set to the last day of the month.

- Algorithm which should be triggered while determining the bill after date.

**Note:** You must create an algorithm using the **C1\_BAFTDRV** algorithm type and attach it to the **Bill After Date Determination** system event.

- Post-processing algorithm which should be triggered once the claim pricing rule is derived.

**Note:** A post-processing algorithm type is not shipped from the product. You need to create a custom algorithm type, if required.

- Price items for which you can define retention type claim based pricing rules using the retention type claim based pricing rule type.
- Rate options that you can use while defining the pricing for a price item.
- Different type of account to which the price item should be billed based on the specified priority.
- Price item parameters which you can use while defining retention type claim based pricing rules.
- Additional information, such as:
  - Whether the price items included in the retention type claim based pricing rule type are used while accumulating specific stop-loss and aggregate stop-loss.
  - Identifiers which help to determine whether the claim transaction is received during the run-in period of the policy.



- Indicates how the claim must be disposed. If the **Claim Disposition** field in the transaction is set to Yes, you must set the disposition mode to **Align Signage**. However, if the **Claim Disposition** field in the transaction is set to **No**, you must set the disposition mode to **Zero Out**.

**Note:** If the **Disposition Mode** field is set to **Align Signage**, the claim based fees is positive for positive claims and the claim based fees is negative for negative claims. However, if the **Disposition Mode** field is set to **Zero Out**, the claim based fees for the negative claims is set to zero (0).

Once a retention type claim based pricing rule type is defined, you can create retention type claim based pricing rules using the retention type claim based pricing rule type. While defining a retention type claim based pricing rule for a parent customer and bill group, you need to specify the following:

- Price item for which you want to define the pricing.
- Pricing date range during which the pricing is effective.
- Rate option which you want to use while defining the retention type claim based pricing.
- Price item parameters based on which you want to define the pricing.

**Note:** You can only use those price item parameters which are included in the respective retention type claim based pricing rule type.

- Flat or percentage based fee which you want to charge for a price item and price item parameters combination.

In addition, while defining a retention type claim based pricing rule for a bill group, you need to specify the status of the policy for which you want to define the retention type claim based pricing rule. You can also specify a pricing group while defining a retention type claim based pricing rule for a bill group. If you specify a pricing group while defining a retention type claim based pricing rule for a bill group, you will have to define the following details for each rule defined in the pricing group:

- Price item parameters based on which you want to define the pricing.

**Note:** You can only use those price item parameters which are included in the respective retention type claim based pricing rule type.

- Flat or percentage based fee which you want to charge for a price item and price item parameters combination.

The system enables you to define different flat or percentage based fee for different set of price item parameters combination. For example, you can define one flat fee for the claim transactions where health coverage is set to Dental and submission type is set to Paper and another flat fee for the claim transactions where health coverage is set to Dental and submission type is set to Paper.

Once a retention type claim based pricing rule is defined for a parent customer and bill group, the system creates one price assignment for each set of price item parameters combination, one price list, and one price list assignment.

## Defining a Retention Type Claim Based Pricing Rule Type

### Prerequisites

To define a retention type claim based pricing rule type, you should have:

- Business Object **C1-PricingRuleRetTypeClaim** defined for retention type claim based pricing rule type.
- Business Object **C1-PricingRule** defined for pricing rule.
- Pricing rule type category for the retention type claim defined in the application.

### Procedure

To define a retention type claim based pricing rule type:

1. Click the **Admin** link in the **Application** toolbar.

A list appears.

- From the **Admin** menu, select **P** and then click **Pricing Rule Type**.

A sub-menu appears.

- Click the **Add** option from the **Pricing Rule Type** sub-menu.

The **Select Business Object** screen appears. It contains the following field:

Field Name	Field Description	Mandatory (Yes or No)
Pricing Rule Type Business Object	Used to indicate the business object using which you want to create the retention type claim based pricing rule type  <b>Note:</b> You can create a retention type claim based pricing rule type using the <b>Claim Pricing Rule Type</b> business object.	Yes

**Tip:** Alternatively, you can access this screen by clicking the **Add** button in the **Page Title** area of the **Pricing Rule Type** screen.

- Select the **Retention Type Claim Based Pricing Rule Type** business object.
- Click **OK**.

The **Retention Type Claim Based Pricing Rule Type** screen appears. It contains the following sections:

- Main** – Used to specify basic details about the retention type claim based pricing rule type.
- Algorithms** – Used to associate the algorithms with the retention type claim based pricing rule type.
- Additional Data** – Used to specify the additional information about the retention type claim based pricing rule type.
- Price Items** – Used to add the price items for which you can define the retention type claim based pricing rules using the retention type claim based pricing rule type.
- Price Item Parameters** – Used to add the price item parameters based on which you want to define the price item pricing.
- Characteristics** – Used to define the characteristics for the retention type claim based pricing rule type.
- Claim Disposition Details** – Used to define the disposition details of the claims transaction.

The **Main** section contains the following fields:

Field Name	Field Description	Mandatory (Yes or No)
Pricing Rule Type	Used to specify the retention type claim based pricing rule type.	Yes
Description	Used to specify the description for the retention type claim based pricing rule type.	Yes
Detailed Description	Used to specify the additional information about the retention type claim based pricing rule type.	No
Pricing Rule Business Object	Used to indicate the retention type claim based pricing rule business object. The valid value is: <ul style="list-style-type: none"> <li>Retention Type Claim Based Pricing Rule</li> </ul>	Yes

Field Name	Field Description	Mandatory (Yes or No)
Business Object	Indicate the retention type claim based pricing rule type business object using which you are defining the retention type claim based pricing rule type.	Not applicable
Status	Used to indicate the status of the retention type claim based pricing rule type. The valid values are: <ul style="list-style-type: none"> <li>Active</li> <li>Inactive</li> </ul>	Yes
Primary	Used to indicate whether the pricing rule type is a primary pricing rule type.  <div style="border: 1px solid black; padding: 2px;"> <b>Note:</b> You must not select the <b>Primary</b> option while defining the retention type claim based pricing rule type. </div>	Not applicable
Pricing Rule Type Category	Used to indicate the category to which the pricing rule type belongs. The valid value is: <ul style="list-style-type: none"> <li>Retention Type Claim Based</li> </ul>	Yes

- Enter the required details in the **Main** section.
- Ensure that **Primary** option is not selected when you are defining a retention type claim based pricing rule type.
- Associate the following algorithms with the retention type claim based pricing rule type:

System Event	Algorithm	Algorithm Type	Description
Pricing Rule Post Processing	C1-PRCRETPOS	C1-PRCRETPOS	Retention Claim Based - Post Processing
Transaction Validation	C1-RETCLMVAL	C1-RETCLMVAL	Retention Claim Based - Validation

- Define additional data for the retention type claim based pricing rule type.
- Add the required price items for retention type claim based pricing rule type.
- Add price item parameters for the retention type claim based pricing rule type.
- Define characteristics for the retention type claim based pricing rule type.
- Add the claim disposition details for retention type claim based pricing rule type.
- Click **Save**.

The retention type claim based pricing rule type is defined.

### Related Topics

For more information on...	See...
<b>Pricing Rule Type</b> screen	<a href="#">Pricing Rule Type</a> on page 2343
How to add the related pricing rule types in the primary pricing rule type	<a href="#">Adding Related Pricing Rule Types in a Primary Pricing Rule Type</a>
How to define the transaction field mapping in the primary pricing rule type	<a href="#">Defining Transaction Field Mapping in a Primary Pricing Rule Type</a>
How to associate algorithms with the pricing rule type	<a href="#">Associating Algorithms with a Pricing Rule Type</a>

For more information on...	See...
How to define additional data for the pricing rule type	<a href="#">Defining Additional Data for a Pricing Rule Type</a>
How to add pricing items in the pricing rule type	<a href="#">Adding Price Items in a Pricing Rule Type</a>
How to add price item parameters in the pricing rule type	<a href="#">Adding a Price Item Parameter in a Pricing Rule Type</a>
How to define characteristics for the pricing rule type	<a href="#">Defining Characteristics for a Pricing Rule Type</a>
How to add claim templates in the claim pricing rule type	<a href="#">Adding Claim Templates in a Claim Pricing Rule Type</a> on page 2359
How to add the claim-specific data in the pricing rule type	<a href="#">Adding the Claim-Specific Data in a Pricing Rule Type</a> on page 2360

## Adding Claim Based Disposition Details in a Pricing Rule Type

### Prerequisites

To add claim based disposition details in a pricing rule type, you should have:

- Pricing rule types defined in the application.
- Account and Price Item Derivation Algorithm defined in the application.
- Claim Disposition and Disposition Mode defined in the application.

### Procedure

To add claim based disposition details in a pricing rule type:

1. Ensure that the **Claim Disposition Details** section is expanded when you are defining or editing for a primary pricing rule type.

The **Claim Disposition Details** section contains the following fields:

Field Name	Field Description	Mandatory (Yes or No)
Claim Disposition	Used to specify the type of claim disposition.	No
Disposition Mode	Used to specify the mode of claim disposition.	No

2. Enter the required details in the **Claim Disposition Details** section.

#### **Note:**

If the **Claim Disposition** field in the transaction is set to **Yes**, you must set the disposition mode to **Align Signage**. However, if the **Claim Disposition** field in the transaction is set to **No**, you must set the disposition mode to **Zero Out**.

If the **Disposition Mode** field is set to **Align Signage**, the claim based fees is positive for positive claims and the claim based fees is negative for negative claims. However, if the **Disposition Mode** field is set to **Zero Out**, the claim based fees for the negative claims is set to zero (0).

3. If you want to define more than one claim disposition entry for the primary pricing rule type, click the **Add (+)** icon and then repeat step 2.

**Note:** However, if you want to remove a claim disposition entry for the primary pricing rule type, click the **Delete**  icon corresponding to the related pricing rule type.

### Related Topics

For more information on...	See...
Defining a retention type claim based pricing rule type	<a href="#">Defining a Retention Type Claim Based Pricing Rule Type</a> on page 2457
How to define related pricing rule types for retention type claim based pricing rule type	<a href="#">Adding Related Pricing Rule Types in a Primary Pricing Rule Type</a>
How to define transaction field mapping for retention type claim based pricing rule type	<a href="#">Defining Transaction Field Mapping in a Primary Pricing Rule Type</a>
How to associate algorithms for retention type claim based pricing rule type	<a href="#">Associating Algorithms with a Pricing Rule Type</a>
How to define additional data for retention type claim based pricing rule type	<a href="#">Defining Additional Data for a Pricing Rule Type</a>
How to define price items for retention type claim based pricing rule type	<a href="#">Adding Price Items in a Pricing Rule Type</a>
How to define price item parameters for retention type claim based pricing rule type	<a href="#">Adding a Price Item Parameter in a Pricing Rule Type</a>
How to define characteristics for pricing rule type	<a href="#">Defining Characteristics for a Pricing Rule Type</a>

## Editing a Retention Type Claim Based Pricing Rule Type

### Prerequisites

To edit the retention type claim based pricing rule type, you should have:

- Business Object **C1-PricingRuleRetTypeClaim** defined for the retention type claim based pricing rule type.
- Business Object **C1-PrcRuleTypRetClaimBase** defined for the retention type claim based pricing rule type.
- Pricing rule type category for the retention type claim based pricing rule type defined in the application

### Procedure

To edit a retention type claim based pricing rule type:

1. Click the **Admin** link in the **Application** toolbar.

A list appears.

2. From the **Admin** menu, select **P** and then click **Pricing Rule Type**.

A sub-menu appears.

3. Click the **Search** option from the **Pricing Rule Type** sub-menu.

The **Pricing Rule Type** screen appears.

4. In the **Pricing Rule Type List** zone, click the **Edit** () icon in the **Edit** column corresponding to the pricing rule type for claim whose details you want to edit.

The **Retention Type Enrollment Based Pricing Rule Type** screen appears. It contains the following sections:

- **Main** – Used to specify basic details about the retention type claim based pricing rule type.

- **Related Pricing Rule Types** – Used to define the pricing rule types which are related to the parent pricing rule type.
- **Transaction Field Mapping** – Used to specify the transaction related data mapped to the pricing rule type
- **Algorithms** – Used to define the algorithms used for the retention type claim based pricing rule type.
- **Additional Data** – Used to specify the additional information about the retention type claim based pricing rule type.
- **Price Items** – Used to define the price items assigned to the retention type claim based pricing rule type.
- **Price Item Parameters** – Used to define the price item parameters in the retention type claim based pricing rule type.
- **Characteristics** – Used to define the characteristics for the retention type claim based pricing rule type.
- **Claim Templates** – Used to define the pricing rule type for retention type claim based template.
- **Claim-Specific Additional Data** – Used to specify the retention type claim based specific additional data.

The **Main** section contains the following fields:

Field Name	Field Description	Mandatory (Yes or No)
Pricing Rule Type	Displays the pricing rule type.	Not applicable
Description	Used to specify the description for the pricing rule type.	Yes
Detailed Description	Used to specify additional information about the pricing rule type.	No
Related Transaction Business Object	Used to indicate the retention type claim based pricing rule type business object. The valid values are: <ul style="list-style-type: none"> <li>• Claim Pricing Rule</li> <li>• Aggregate Stop-Loss (ASL) Pricing Rule</li> <li>• Specific Stop-Loss (SSL) Pricing Rule</li> <li>• Retention Type Claim Based Pricing Rule</li> <li>• Retention Type Enrollment Based Pricing Rule</li> </ul>	Yes
Business Object	Displays the retention type claim based pricing rule type business object for retention type claim.	Not applicable
Status	Used to indicate the status of the retention type claim based pricing rule type. The valid values are: <ul style="list-style-type: none"> <li>• Active</li> <li>• Inactive</li> </ul>	
Primary	Used to select the checkbox if the retention type claim based pricing rule type is primary.	No

Field Name	Field Description	Mandatory (Yes or No)
Pricing Rule Type Category	Used to indicate the pricing rule type category for the retention type claim based pricing rule type. The valid values are: <ul style="list-style-type: none"> <li>Aggregate Stop-Loss</li> <li>Claim</li> <li>Discounted Agreement</li> <li>Retention Type Claim Based</li> <li>Retention Type Enrollment Based</li> <li>Specific Stop-Loss</li> </ul>	Yes

**Tip:** Alternatively, you can click the **Edit** button in the **Pricing Rule Type** zone to edit the pricing rule type for retention type claim.

- Modify the details in the **Main** section, if required.
- Add, edit, or remove the related pricing rule types in the retention type claim based pricing rule type, if required.
- Modify the transaction field mapping in the retention type claim based pricing rule type, if required.
- Add, edit, or remove algorithms with the retention type claim based pricing rule type, if required.
- Modify the additional data for the retention type claim based pricing rule type, if required.
- Add, edit, or remove pricing items in the retention type claim based pricing rule type, if required.
- Add, edit, or remove price item parameters in the retention type claim based pricing rule type, if required.
- Add, edit, or remove characteristics for the retention type claim based pricing rule type, if required.
- Add, edit, or remove claim templates in the retention type claim based pricing rule type, if required.
- Modify the claim-specific data in the retention type claim based pricing rule type, if required.
- Click **Save**.

The changes made to the Retention Type Claim Based Pricing Rule Type are saved.

### **Related Topics**

For more information on...	See...
<b>Pricing Rule Type</b> screen	<a href="#">Pricing Rule Type</a> on page 2343
<b>Pricing Rule Type List</b> zone	<a href="#">Pricing Rule Type List</a> on page 2344
<b>Pricing Rule Type</b> zone	<a href="#">Pricing Rule Type</a> on page 2347

## **Deleting a Retention Type Claim Based Pricing Rule Type**

### **Procedure**

To delete a retention type claim based pricing rule type:

- Click the **Admin** link in the **Application** toolbar.  
A list appears.
- From the **Admin** menu, select **P** and then click **Pricing Rule Type**.  
A sub-menu appears.

- Click the **Search** option from the **Pricing Rule Type** sub-menu.

The **Pricing Rule Type** screen appears.

- In the **Pricing Rule Type List** zone, click the **Delete** (🗑️) icon in the **Delete** column corresponding to the retention type claim based pricing rule type that you want to delete.

A message appears confirming whether you want to delete the retention type claim based pricing rule type.

**Note:** You can delete a retention type claim based pricing rule type only when it is not yet used in the system.

**Tip:** Alternatively, you can delete a retention type claim based pricing rule type by clicking the **Delete** button in the **Pricing Rule Type** zone.

- Click **OK**.

The retention type claim based pricing rule type is deleted.

### Related Topics

For more information on...	See...
<b>Pricing Rule Type</b> screen	<a href="#">Pricing Rule Type</a> on page 2343
<b>Pricing Rule Type List</b> zone	<a href="#">Pricing Rule Type List</a> on page 2344
<b>Pricing Rule Type</b> zone	<a href="#">Pricing Rule Type</a> on page 2347

## Viewing the Retention Type Claim Based Pricing Rule Type Details

### Procedure

To view the details of a retention type claim based pricing rule type:

- Click the **Admin** link in the **Application** toolbar.

A list appears.

- From the **Admin** menu, select **P** and then click **Pricing Rule Type**.

A sub-menu appears.

- Click the **Search** option from the **Pricing Rule Type** sub-menu.

The **Pricing Rule Type** screen appears.

- In the **Pricing Rule Type List** zone, click the **Broadcast** (📡) icon corresponding to the retention type claim based pricing rule type whose details you want to view.

The **Pricing Rule Type** zone appears.

- View the details of the retention type claim based pricing rule type in the **Pricing Rule Type** zone.

### Related Topics

For more information on...	See...
<b>Pricing Rule Type</b> screen	<a href="#">Pricing Rule Type</a> on page 2343
<b>Pricing Rule Type List</b> zone	<a href="#">Pricing Rule Type List</a> on page 2344
<b>Pricing Rule Type</b> zone	<a href="#">Pricing Rule Type</a> on page 2347



## Defining a Retention Type Claim Based Pricing Rule for a Parent Customer

### Prerequisites

To define a retention type claim based pricing rule for a parent customer, you should have:

- Business Object **C1-PricingRule** defined for the pricing rule.
- Business Object **C1-PricingRuleRetTypeClaim** defined for retention type claim based pricing rule type.
- Algorithms **C1-APPTXNBAS**, **C1-PRCRETPOS**, and **C1-RETCLMVAL** defined for retention type claim based pricing rule type.

**Note:** A custom algorithm type must be created to validate a transaction.

### Procedure

To define a retention type claim based pricing rule for a parent customer:

1. Search for a parent customer in the **Customer 360° View** screen.

The **Search Result** screen appears.

2. In the **Search Results** section, click the **View**  icon corresponding to the parent customer whose pricing details you want to view.

The **Person** tab appears in the **Customer 360° Information** screen.

3. Click the **Pricing** tab.

The **Pricing** tab appears.

4. Click the **Add** link in the upper-right corner of the **Parent Customer Pricing Rules** zone.

The **Pricing Rule** screen appears. It contains the following fields:

Field Name	Field Description	Mandatory (Yes or No)
Person Name	Indicates the parent customer for whom you want to create a discount arrangement pricing rule type.	Not applicable
Person Type	Displays the person type.	Not applicable
Pricing Rule Type	Used to indicate the pricing rule type. The valid values is: <ul style="list-style-type: none"> <li>• Retention Type Claim Based Pricing Rule</li> </ul>	Yes

**Note:** If the pricing rule type is not selected then the application displays an error message.

5. Select the required pricing rule type in the respective field.

6. Click **OK**.









The **Retention Type Claim Based Pricing Rule** screen appears. It contains the following sections:

- **Customer Information** - Displays information about the parent customer for whom you are defining the retention type claim based pricing rule. It contains the following fields:

Field Name	Field Description
Parent Customer Information	Indicates the parent customer for whom you are defining the retention type claim based pricing rule.
Pricing Rule Type	Indicates the pricing rule type using which you are defining the retention type claim based pricing rule.

- **Main** - This section contains the following fields:

Field Name	Field Description	Mandatory (Yes or No)
Price Item	Used to indicate the price item for which you want to define the retention type claim based pricing. The valid value is: <ul style="list-style-type: none"> <li>• Admin Fee</li> </ul>	Yes
Pricing Start Date	Used to specify the start date from when the retention type claim based pricing will be effective for the price item. <div style="border: 1px solid black; padding: 2px; margin-top: 5px;"><b>Note:</b> The pricing start date cannot be later than the pricing end date.</div>	Yes (Conditional) <div style="border: 1px solid black; padding: 2px; margin-top: 5px;"><b>Note:</b> Pricing Start Date should be entered if Pricing End Date has been mentioned.</div>
Pricing End Date	Used to specify the end date till when the retention type claim based pricing will be effective for the price item. <div style="border: 1px solid black; padding: 2px; margin-top: 5px;"><b>Note:</b> The pricing end date cannot be earlier than the pricing start date.</div>	No

Field Name	Field Description	Mandatory (Yes or No)									
Rate Option	<p>Used to indicate the rate option that you want to use while defining the pricing for the price item. The valid value is:</p> <ul style="list-style-type: none"> <li>Flat Dollar Per Claim - Agg Daily</li> </ul> <p>On selecting an option from the <b>Rate Option</b> field, following fields appear in a grid:</p> <table border="1" data-bbox="516 453 1260 1667"> <thead> <tr> <th data-bbox="516 453 667 569">Field Name</th> <th data-bbox="667 453 1114 569">Field Description</th> <th data-bbox="1114 453 1260 569">Mandatory (Yes or No)</th> </tr> </thead> <tbody> <tr> <td data-bbox="516 569 667 1100">Price Item Parameter</td> <td data-bbox="667 569 1114 1100"> <p>Used to specify multiple price item parameters based on which you want to determine the price item utilization.</p> <div data-bbox="678 688 1097 1083" style="border: 1px solid black; padding: 5px;"> <p><b>Note:</b></p> <p>The Search  icon appears corresponding to the <b>Price Item Parameter</b> field. On clicking the <b>Search</b> icon, the <b>Price Item Parameter Search</b> screen appears.</p> <p>On specifying the price item, the description of the price item appears corresponding to the <b>Price Item Parameter</b> field.</p> </div> </td> <td data-bbox="1114 569 1260 1100">No</td> </tr> <tr> <td data-bbox="516 1100 667 1667">Parameter Value</td> <td data-bbox="667 1100 1114 1667"> <p>Used to specify multiple price item parameter values based on which you want to determine the price item utilization.</p> <div data-bbox="678 1255 1097 1650" style="border: 1px solid black; padding: 5px;"> <p><b>Note:</b></p> <p>The Search  icon appears corresponding to the <b>Parameter Value</b> field. On clicking the <b>Search</b> icon, the <b>Predefined Parameter Value Search</b> screen appears.</p> <p>On specifying the price item, the description of the price item appears corresponding to the <b>Parameter Value Search</b> field.</p> </div> </td> <td data-bbox="1114 1100 1260 1667">No</td> </tr> </tbody> </table> <div data-bbox="516 1692 1260 2018" style="border: 1px solid black; padding: 5px; margin-top: 10px;"> <p><b>Note:</b></p> <p>If you want to define more than one price item parameter to the price item in a retention type claim based pricing rule type, click the <b>Add</b>  icon.</p> <p>However, if you want to remove a price item parameter from the price item in a retention type claim based pricing rule type, click the <b>Delete</b>  icon corresponding to the <b>Price Item Parameter</b> field.</p> </div>	Field Name	Field Description	Mandatory (Yes or No)	Price Item Parameter	<p>Used to specify multiple price item parameters based on which you want to determine the price item utilization.</p> <div data-bbox="678 688 1097 1083" style="border: 1px solid black; padding: 5px;"> <p><b>Note:</b></p> <p>The Search  icon appears corresponding to the <b>Price Item Parameter</b> field. On clicking the <b>Search</b> icon, the <b>Price Item Parameter Search</b> screen appears.</p> <p>On specifying the price item, the description of the price item appears corresponding to the <b>Price Item Parameter</b> field.</p> </div>	No	Parameter Value	<p>Used to specify multiple price item parameter values based on which you want to determine the price item utilization.</p> <div data-bbox="678 1255 1097 1650" style="border: 1px solid black; padding: 5px;"> <p><b>Note:</b></p> <p>The Search  icon appears corresponding to the <b>Parameter Value</b> field. On clicking the <b>Search</b> icon, the <b>Predefined Parameter Value Search</b> screen appears.</p> <p>On specifying the price item, the description of the price item appears corresponding to the <b>Parameter Value Search</b> field.</p> </div>	No	Not applicable
Field Name	Field Description	Mandatory (Yes or No)									
Price Item Parameter	<p>Used to specify multiple price item parameters based on which you want to determine the price item utilization.</p> <div data-bbox="678 688 1097 1083" style="border: 1px solid black; padding: 5px;"> <p><b>Note:</b></p> <p>The Search  icon appears corresponding to the <b>Price Item Parameter</b> field. On clicking the <b>Search</b> icon, the <b>Price Item Parameter Search</b> screen appears.</p> <p>On specifying the price item, the description of the price item appears corresponding to the <b>Price Item Parameter</b> field.</p> </div>	No									
Parameter Value	<p>Used to specify multiple price item parameter values based on which you want to determine the price item utilization.</p> <div data-bbox="678 1255 1097 1650" style="border: 1px solid black; padding: 5px;"> <p><b>Note:</b></p> <p>The Search  icon appears corresponding to the <b>Parameter Value</b> field. On clicking the <b>Search</b> icon, the <b>Predefined Parameter Value Search</b> screen appears.</p> <p>On specifying the price item, the description of the price item appears corresponding to the <b>Parameter Value Search</b> field.</p> </div>	No									

Field Name	Field Description	Mandatory (Yes or No)
Fee	Used to specify the fee for the price item parameter.	

- **Characteristics** - Used to define the characteristics for the retention type claim based pricing rule for parent customer.

7. Add the required details in the main and characteristics section.

8. Click **Save**.

The retention type claim based pricing rule for a parent customer is defined.

**Note:**

If the approval workflow group setting is set as **Active** for the parent customer, for which the retention type claim based pricing rule is defined then an approval transaction is created for that particular parent customer. The retention type claim based pricing rule for a parent customer is defined, once the approval transaction is approved.

**Related Topics**

For more information on...	See...
How to define characteristics for a retention type claim based pricing rule.	<a href="#">Defining Characteristics for a Retention Type Claim Based Pricing Rule</a> on page 2468

## Defining Characteristics for a Retention Type Claim Based Pricing Rule

**Prerequisites**

To define characteristics for a retention type claim based pricing rule, you should have:

- Characteristic types defined in the application (where the characteristic entity is set to **Pricing Rule**)

**Procedure**

To define characteristics for a retention type claim based pricing rule:

1. Ensure that the **Characteristics** section is expanded when you are defining or editing a retention type claim based pricing rule.

The **Characteristics** section contains the following fields in a grid:

Field Name	Field Description	Mandatory (Yes or No)
Effective Date	Used to specify from when the pricing rule will be effective.	Yes
Characteristic Type	Used to indicate the characteristic type for the retention type claim based pricing rule of a parent customer.	Yes (Conditional)

**Note:** This field is required when you are defining a characteristic for retention type claim based pricing rule.

Field Name	Field Description	Mandatory (Yes or No)
Characteristic Value	<p>Used to specify the characteristic value for the retention type claim based pricing rule of a parent customer.</p> <p><b>Note:</b></p> <p>If you select a predefined characteristic type, the <b>Search</b>  icon appears corresponding to the <b>Characteristic Value</b> field. On clicking the <b>Search</b> icon, the <b>Predefined Characteristic Search</b> window appears.</p> <p>On specifying the value for a predefined characteristic type, the description of the characteristic value appears corresponding to the <b>Characteristic Value</b> field.</p>	<p>Yes (Conditional)</p> <p><b>Note:</b> This field is required when you are defining a characteristic for retention type claim based pricing rule.</p>

- Enter the required details in the **Characteristics** section.
- If you want to define more than one characteristic for retention type claim based pricing rule, click the **Add**  icon and then repeat step 2.

**Note:** However, if you want to remove a characteristic from retention type claim based pricing rule, click the **Delete**  icon corresponding to the characteristic.

- Click **Save**.

The characteristics are defined for the retention type claim based pricing rule.

### Related Topics

For more information on...	See...
How to define a retention type claim based pricing rule for a parent customer	<a href="#">Defining a Retention Type Claim Based Pricing Rule for a Parent Customer</a> on page 2465

## Editing a Retention Type Claim Based Pricing Rule of a Parent Customer

### Prerequisites

To edit a retention type claim based pricing rule of a parent customer, you should have:

- Business Object **C1-PricingRule** defined for the pricing rule.
- Business Object **C1-PricingRuleRetTypeClaim** defined for retention type claim based pricing rule type.
- Algorithms **C1-APPTXNBAS**, **C1-PRCRETPOS**, and **C1-RETCLMVAL** defined for retention type claim based pricing rule type.

**Note:** A custom algorithm type must be created to validate a transaction.

### Procedure

To edit a retention type claim based pricing rule of a parent customer:

- Search for a parent customer in the **Customer 360° View** screen.
- In the **Search Results** section, click the **View**  icon corresponding to the parent customer whose pricing details you want to view.

The **Person** tab appears in the **Customer 360° Information** screen.

- Click the **Pricing** tab. It consists of the following zones:

The **Pricing** tab appears.

4.

In the **Parent Customer Pricing Rules** zone, click the **Edit**  icon in the **Edit** column corresponding to the retention type claim based pricing rule, whose details you want to edit.









The **Retention Type Claim Based Pricing Rule** screen appears. It contains the following zones:

- **Customer Information** - Displays information about the parent customer for whom the retention type claim based pricing rule is defined. It contains the following fields:

Field Name	Field Description
Parent Customer Information	Indicates the parent customer for whom the discount arrangement pricing rule is defined.
Pricing Rule Type	Displays the pricing rule type that is chosen to define the retention type claim based pricing rule of a parent customer.

- **Main** - This section contains the following fields:

Field Name	Field Description	Mandatory (Yes or No)
Price Item	Indicates the price item for which you want to define the pricing.	Not applicable
Pricing Start Date	Used to specify the start date from when the pricing will be effective for the price item.  <b>Note:</b> The pricing start date cannot be later than the pricing end date.	Yes (Conditional)  <b>Note:</b> Pricing Start Date should be entered if Pricing End Date has been mentioned.
Pricing End Date	Used to specify the end date till when the pricing will be effective for the price item.  <b>Note:</b> The pricing end date cannot be earlier than the pricing start date.	No

Field Name	Field Description	Mandatory (Yes or No)									
Rate Option	<p>Used to indicate the rate option that you want to use while defining the pricing for the price item. The valid value is:</p> <ul style="list-style-type: none"> <li>Flat Dollar Per Claim - Agg Daily</li> </ul> <p>On clicking the <b>Add</b> () icon, the following fields appear in a grid:</p> <table border="1" data-bbox="548 472 1247 1686"> <thead> <tr> <th data-bbox="548 472 667 583">Field Name</th> <th data-bbox="672 472 1101 583">Field Description</th> <th data-bbox="1105 472 1247 583">Mandatory (Yes or No)</th> </tr> </thead> <tbody> <tr> <td data-bbox="548 590 667 1119">Price Item Parameter</td> <td data-bbox="672 590 1101 1119"> <p>Used to specify multiple price item parameters based on which you want to determine the price item utilization.</p> <div data-bbox="678 709 1084 1102" style="border: 1px solid black; padding: 5px;"> <p><b>Note:</b></p> <p>The Search () icon appears corresponding to the <b>Price Item Parameter</b> field. On clicking the <b>Search</b> icon, the <b>Price Item Parameter Search</b> screen appears.</p> <p>On specifying the price item, the description of the price item appears corresponding to the <b>Price Item Parameter</b> field.</p> </div> </td> <td data-bbox="1105 590 1247 1119">No</td> </tr> <tr> <td data-bbox="548 1125 667 1686">Parameter Value</td> <td data-bbox="672 1125 1101 1686"> <p>Used to specify multiple price item parameter values based on which you want to determine the price item utilization.</p> <div data-bbox="678 1276 1084 1669" style="border: 1px solid black; padding: 5px;"> <p><b>Note:</b></p> <p>The Search () icon appears corresponding to the <b>Parameter Value</b> field. On clicking the <b>Search</b> icon, the <b>Predefined Parameter Value Search</b> screen appears.</p> <p>On specifying the price item, the description of the price item appears corresponding to the <b>Parameter Value Search</b> field.</p> </div> </td> <td data-bbox="1105 1125 1247 1686">No</td> </tr> </tbody> </table> <div data-bbox="548 1707 1247 2072" style="border: 1px solid black; padding: 5px; margin-top: 10px;"> <p><b>Note:</b></p> <p>If you want to define more than one price item parameter to the price item in a retention type claim based pricing rule type, click the <b>Add</b> () icon.</p> <p>However, if you want to remove a price item parameter from the price item in a retention type claim based pricing rule type, click the <b>Delete</b> () icon corresponding to the <b>Price Item Parameter</b> field.</p> </div>	Field Name	Field Description	Mandatory (Yes or No)	Price Item Parameter	<p>Used to specify multiple price item parameters based on which you want to determine the price item utilization.</p> <div data-bbox="678 709 1084 1102" style="border: 1px solid black; padding: 5px;"> <p><b>Note:</b></p> <p>The Search () icon appears corresponding to the <b>Price Item Parameter</b> field. On clicking the <b>Search</b> icon, the <b>Price Item Parameter Search</b> screen appears.</p> <p>On specifying the price item, the description of the price item appears corresponding to the <b>Price Item Parameter</b> field.</p> </div>	No	Parameter Value	<p>Used to specify multiple price item parameter values based on which you want to determine the price item utilization.</p> <div data-bbox="678 1276 1084 1669" style="border: 1px solid black; padding: 5px;"> <p><b>Note:</b></p> <p>The Search () icon appears corresponding to the <b>Parameter Value</b> field. On clicking the <b>Search</b> icon, the <b>Predefined Parameter Value Search</b> screen appears.</p> <p>On specifying the price item, the description of the price item appears corresponding to the <b>Parameter Value Search</b> field.</p> </div>	No	Not applicable
Field Name	Field Description	Mandatory (Yes or No)									
Price Item Parameter	<p>Used to specify multiple price item parameters based on which you want to determine the price item utilization.</p> <div data-bbox="678 709 1084 1102" style="border: 1px solid black; padding: 5px;"> <p><b>Note:</b></p> <p>The Search () icon appears corresponding to the <b>Price Item Parameter</b> field. On clicking the <b>Search</b> icon, the <b>Price Item Parameter Search</b> screen appears.</p> <p>On specifying the price item, the description of the price item appears corresponding to the <b>Price Item Parameter</b> field.</p> </div>	No									
Parameter Value	<p>Used to specify multiple price item parameter values based on which you want to determine the price item utilization.</p> <div data-bbox="678 1276 1084 1669" style="border: 1px solid black; padding: 5px;"> <p><b>Note:</b></p> <p>The Search () icon appears corresponding to the <b>Parameter Value</b> field. On clicking the <b>Search</b> icon, the <b>Predefined Parameter Value Search</b> screen appears.</p> <p>On specifying the price item, the description of the price item appears corresponding to the <b>Parameter Value Search</b> field.</p> </div>	No									

Field Name	Field Description	Mandatory (Yes or No)
Fee	Used to specify the fee for the price item parameter.	Not applicable

- **Characteristics** - Used to define the characteristics for the retention type claim based pricing rule for parent customer. It contains the following fields:

Field Name	Field Description	Mandatory (Yes or No)
Effective Date	Used to specify the effective date from when the characteristic is effective for the retention type claim based pricing rule of a parent customer.	No
Characteristic Type	Used to indicate the characteristic type for the retention type claim based pricing rule of a parent customer.	No
Characteristic Value	Used to specify the characteristic value for the retention type claim based pricing rule of a parent customer.  <div style="border: 1px solid black; padding: 5px;"> <p><b>Note:</b> If you select a predefined characteristic type, the <b>Search</b>  icon appears corresponding to the Characteristic Value field. On clicking the <b>Search</b> icon, the Predefined Characteristic Search window appears. On specifying the value for a predefined characteristic type, the description of the characteristic value appears corresponding to the Characteristic Value field.</p> </div>	No

**Note:**

If the approval workflow group setting is set as **Active** for the parent customer, for which the retention type claim based pricing rule is edited then an approval transaction is created for that particular parent customer. The retention type claim based pricing rule for a parent customer is defined, once the approval transaction is approved.



5. Click **Save**.

The retention type claim based pricing rule of a parent customer is edited.

## Deleting a Retention Type Claim Based Pricing Rule of a Parent Customer

### Procedure

To delete a retention type claim based pricing rule of a parent customer:

1. Search for a parent customer in the **Customer 360° Information** screen.
2. In the **Search Results** section, click the **View**  icon corresponding to the parent customer whose pricing details you want to view.  
  
The **Person** tab in the **Customer 360° Information** screen.
3. Click the **Pricing** tab. It consists of the following zones:  
  
The **Pricing** tab appears.
4. In the **Parent Customer Pricing Rules** zone, click the **Delete**  icon in the **Delete** column corresponding to the retention type claim based pricing rule that you want to delete.



A message appears confirming whether you want to delete the retention type claim based pricing rule type of a parent customer.

5. Click **OK**.

The retention type claim based pricing rule of a parent customer is deleted.

### Related Topics

For more information on...	See...
How to search for a parent customer	<a href="#">Searching for a Person</a> on page 185
<b>Parent Customer Pricing Rules</b> zone	<a href="#">Parent Customer Pricing Rules</a> on page 231

## Defining a Retention Type Claim Based Pricing Rule for a Bill Group

### Prerequisites

To define a retention type claim based pricing rule for a bill group, you should have:

- Business Object **C1-PricingRule** and **C1-PricingRuleType**, and **C1-PricingGroup** defined for the pricing rule.
- Business Object **C1-PolicyBOStatusReason** defined for the policy status.
- Business Object **C1-PricingRuleRefTypeClaim** defined for retention type claim based pricing rule type.
- Algorithms **C1-APPTXNBAS**, **C1-PRCRETPOS**, **C1-RETCLMVAL**, **C1-PRRTPREP**, **C1-PRCRLTY** defined for retention type claim based pricing rule type.

**Note:** A custom algorithm type must be created to validate a transaction.

### Procedure

To define a retention type claim based pricing rule for a bill group:

1. Search for the Administrative Services Only (ASO) person, whose person type is set to **Bill Group**, in the **Customer 360° View** screen.
2. In the **Search Results** section, click the **View** () icon corresponding to the person whose pricing details you want to view.

The **Person** tab appears in the **Customer 360° Information** screen.

3. Click the **Pricing** tab.

The **Pricing** tab appears.

4. Click the **Broadcast** () icon in the **Bill Group ASO Policy Information** zone, corresponding to the **Bill Group Information** column, whose bill group details you want to view.

The **Bill Group ASO Policy Pricing Rules** zone is displayed.

5. Click the **Add** link in the upper right corner of the **Bill Group ASO Policy Pricing Rules** zone.

The **Pricing Rule** screen appears. It contains the following fields:

Field Name	Field Description	Mandatory (Yes or No)
Person Name	Indicates the name of the parent customer.	Not applicable

Field Name	Field Description	Mandatory (Yes or No)
Person Type	Indicates the type of the parent customer.  <b>Note:</b> If you are defining the pricing rule type for the parent customer, then the person type will be <b>Parent Customer</b> .	Not applicable
Pricing Rule Type	Used to indicate the pricing rule type using which you want to create a retention type claim based pricing rule.  <b>Note:</b> Select the <b>Retention Type Claim Based Pricing Rule Type</b> option, as the pricing rule type.	Yes  <b>Note:</b> If the pricing rule type is not selected then the application displays an error message.
Pricing Group	Used to indicate the pricing group for the bill group.  <b>Note:</b> Select the pricing group option only when the retention type claim based pricing rule has to be defined for a bill group using the pricing group.	No
Policy Status	Used to indicate the policy status for the bill group. The valid values are: <ul style="list-style-type: none"> <li>• In Force/Active</li> <li>• Post Runout</li> <li>• Runout</li> </ul>	Yes (Conditional)  <b>Note:</b> Policy Status is required once the Pricing Rule Type is selected.



6. Select the appropriate fields in the **Main** section.

7. Click **OK**.

The **Retention Type Claim Based Pricing Rule** screen appears. It contains the following sections:

- **Main** - This section contains the following fields:

Field Name	Field Description	Mandatory (Yes or No)
Price Item	Used to indicate the price item for which you want to define the pricing. The valid value are: <ul style="list-style-type: none"> <li>• Admin Fee</li> </ul>	Yes
Pricing Start Date	Used to specify the start date from when the pricing will be effective for the price item.	Yes (Conditional)  <b>Note:</b> Pricing Start Date should be entered if Pricing End Date has been mentioned.
Pricing End Date	Used to specify the end date till when the pricing will be effective for the price item.	No
Rate Option	Used to specify the rate option for the price item. The valid value are: <ul style="list-style-type: none"> <li>• Flat Dollar Per Claim - Agg Daily</li> </ul>	Yes

Field Name	Field Description	Mandatory (Yes or No)
Price Item Parameter	Used to specify multiple price item parameters based on which you want to determine the price item utilization.  <b>Note:</b> The Search  icon does appear corresponding to this field. On clicking the <b>Search</b> icon, the <b>Price Item Parameters</b> screen appears.	No
Parameter Value	Used to specify multiple price item parameter values based on which you want to determine the price item utilization.  <b>Note:</b> The Search  icon does appear corresponding to this field. On clicking the <b>Search</b> icon, the <b>Parameter Value Search</b> screen appears.	No
Fee	Used to specify the fee for the price item parameter.	No

- **Characteristics** - Used to define the characteristics for the retention type claim based pricing rule for a bill group.

8. Add the required details in the main and characteristics section.
9. Click **Save**.

The retention type claim based pricing rule for a bill group is defined.

**Note:**  
If the approval workflow group setting is set as **Active** for the bill group, for which the retention type claim based pricing rule is defined then an approval transaction is created for that particular bill group. The retention type claim based pricing rule for a bill group is defined, once the approval transaction is approved.

### Related Topics

For more information on...	See...
How to define characteristics for a retention type claim based pricing rule.	<a href="#">Defining Characteristics for a Retention Type Claim Based Pricing Rule</a> on page 2475

## Defining Characteristics for a Retention Type Claim Based Pricing Rule

### Prerequisites

To define characteristics for a retention type claim based pricing rule, you should have:

- Characteristic types defined in the application (where the characteristic entity is set to **Pricing Rule**)

### Procedure

To define characteristics for a retention type claim based pricing rule:

1. Ensure that the **Characteristics** section is expanded when you are defining or editing a retention type claim based pricing rule.

The **Characteristics** section contains the following columns in a grid:

Column Name	Column Description	Mandatory (Yes or No)
Effective Date	Used to specify from when the pricing rule will be effective.	Yes
Characteristic Type	Used to indicate the characteristic type. The valid values are: <ul style="list-style-type: none"> <li>Eligible for Billing</li> </ul> <div style="border: 1px solid black; padding: 5px; margin-top: 10px;"> <b>Note:</b> The list includes only those characteristic types where the characteristic entity is set to <b>Pricing Rule Type</b>. </div>	Yes (Conditional) <div style="border: 1px solid black; padding: 5px; margin-top: 10px;"> <b>Note:</b> This field is required when you are defining a characteristic for retention type claim based pricing rule. </div>
Characteristic Value	Used to specify the value for the characteristic type. <div style="border: 1px solid black; padding: 5px; margin-top: 10px;"> <b>Note:</b>  If you select a predefined characteristic type, the <b>Search</b>  icon appears corresponding to the <b>Characteristic Value</b> field. On clicking the <b>Search</b> icon, the <b>Predefined Characteristic Search</b> window appears.   On specifying the value for a predefined characteristic type, the description of the characteristic value appears corresponding to the <b>Characteristic Value</b> field. </div>	Yes (Conditional) <div style="border: 1px solid black; padding: 5px; margin-top: 10px;"> <b>Note:</b> This field is required when you are defining a characteristic for retention type claim based pricing rule. </div>

- Enter the required details in the **Characteristics** section.
- If you want to define more than one characteristic for retention type claim based pricing rule, click the **Add**  icon and then repeat step 2.

**Note:** However, if you want to remove a characteristic from retention type claim based pricing rule, click the **Delete**  icon corresponding to the characteristic.

- Click **Save**.

The characteristics are defined for the retention type claim based pricing rule.

### Related Topics

For more information on...	See...
How to define a retention type claim based pricing rule for a bill group	<a href="#">Defining a Retention Type Claim Based Pricing Rule for a Bill Group</a> on page 2473

## Editing a Retention Type Claim Based Pricing Rule of a Bill Group

### Prerequisites

To edit a retention type claim based pricing rule of a parent customer, you should have:

- Business Object **C1-PricingRule** defined for the pricing rule.
- Business Object **C1-PricingRuleRetTypeClaim** defined for retention type claim based pricing rule type.
- Algorithms **C1-APPTXNBAS**, **C1-PRCRETPOS**, and **C1-RETCLMVAL** defined for retention type claim based pricing rule type.

**Note:** A custom algorithm type must be created to validate a transaction.

## Procedure

To edit a retention type claim based pricing rule of a bill group:

1. Search for a bill group in the **Customer 360° View** screen.
2. In the **Search Results** section, click the **View** () icon corresponding to the bill group whose pricing details you want to view.

The **Person** tab appears in the **Customer 360° Information** screen.

3. Click the **Pricing** tab.  
The **Pricing** tab appears.
4. Click the **Broadcast** () icon in the **Bill Group ASO Policy Information** zone, corresponding to the **Bill Group Information** column, whose bill group details you want to view.

The **Bill Group ASO Policy Pricing Rules** zone appears.

5. Click the **Edit** () icon in the **Bill Group ASO Policy Pricing Rules** zone, corresponding to the **Pricing Rule Type** column, whose details you want to edit.



The **Retention Type Claim Based Pricing Rule** screen appears. It contains the following zones:

- **Customer Information** - Displays the basic information about the customer. It contains the following fields:

Column Name	Column Description
Bill Group Information	Displays the bill group name.
Policy Start Date	Displays the date from when the policy is effective.
Policy End Date	Displays the date till when the policy is effective.
Policy Status	Displays the status of the policy.
Pricing Rule Type	Displays the pricing rule type that is chosen to define the retention type claim based pricing rule of a bill group.

- **Main** - This section contains the following fields:

Field Name	Field Description	Mandatory (Yes or No)
Price Item	Indicates the price item for which you want to define the pricing.	Not applicable
Pricing Start Date	Used to specify the start date from when the pricing will be effective for the price item.	Yes (Conditional) <b>Note:</b> Pricing Start Date should be entered if Pricing End Date has been mentioned.
Pricing End Date	Used to specify the end date till when the pricing will be effective for the price item.	No
Rate Option	Indicates the rate option for the price item.	Not applicable

Field Name	Field Description	Mandatory (Yes or No)
Price Item Parameter	Used to specify multiple price item parameters based on which you want to determine the price item utilization.  <b>Note:</b> The Search  icon does appear corresponding to this field. On clicking the <b>Search</b> icon, the <b>Price Item Parameters</b> screen appears.	No
Parameter Value	Used to specify multiple price item parameter values based on which you want to determine the price item utilization.  <b>Note:</b> The Search  icon does appear corresponding to this field. On clicking the <b>Search</b> icon, the <b>Parameter Value Search</b> screen appears.	No
Fee	Indicates the fee for the price item parameter.	Not applicable

- **Characteristics** - Used to define the characteristics for the retention type claim based pricing rule for parent customer. It contains the following fields:

Field Name	Field Description	Mandatory (Yes or No)
Effective Date	Used to specify the effective date from when the characteristic is effective for the retention type claim based pricing rule of a bill group.	No
Characteristic Type	Used to indicate the characteristic type for the retention type claim based pricing rule of a bill group. The valid values are: <ul style="list-style-type: none"> <li>• Eligible for Billing</li> </ul>	No
Characteristic Value	Used to specify the characteristic value for the retention type claim based pricing rule of a bill group.  <b>Note:</b> If you select a predefined characteristic type, the <b>Search</b>  icon appears corresponding to the Characteristic Value field. On clicking the <b>Search</b> icon, the Predefined Characteristic Search window appears. On specifying the value for a predefined characteristic type, the description of the characteristic value appears corresponding to the Characteristic Value field.	No

6. Click **Save**.

The **Approval Transaction Information** pop-up window appears with the Approval Transaction ID that is generated by the application.

7. Click **OK**

The retention type claim based pricing rule of a bill group is edited.

**Note:**

If the approval workflow group setting is set as **Active** for the bill group, for which the retention type claim based pricing rule is defined then an approval transaction is created for that particular bill group. The retention type claim based pricing rule for a bill group is defined, once the approval transaction is approved.

**Related Topics**

For more information on...	See...
How to define a retention type claim based pricing rule of a parent customer	<a href="#">Defining a Retention Type Claim Based Pricing Rule for a Parent Customer</a> on page 2465

**Deleting a Retention Type Claim Based Pricing Rule of a Bill Group****Procedure**

To delete a retention type claim based pricing rule of a bill group:

1. Search for a bill group in the **Customer 360° View** screen.
2. In the **Search Results** section, click the **View** (🔍) icon corresponding to the bill group whose pricing details you want to view.

The **Person** tab appears in the **Customer 360° Information** screen.

3. Click the **Pricing** tab.

The **Pricing** tab appears.

4. Click the **Broadcast** (📡) icon in the **Bill Group ASO Policy Information** zone, corresponding to the **Bill Group Information** column, whose bill group details you want to delete.

The **Bill Group ASO Policy Pricing Rules** zone appears.

5. Click the **Delete** (🗑️) icon in the **Delete** column corresponding to the **Pricing Group Information** column, whose bill group information you want to delete.

A message appears confirming whether you want to delete the retention type claim based pricing rule of a bill group.

**Note:** You can delete a retention type claim based pricing rule only when it is not yet used in the system.

6. Click **OK**.

The retention type claim based pricing rule of a bill group is deleted.

**Related Topics**

For more information on...	See...
How to define characteristics for a retention type claim based pricing rule.	<a href="#">Defining Characteristics for a Retention Type Claim Based Pricing Rule</a> on page 2468

**Defining a Retention Type Claim Based Pricing Rule for a Bill Group Using a Pricing Group****Procedure**

To define a retention type claim based pricing rule for a bill group using pricing group:

1. Search for the Administrative Services Only (ASO) person, whose person type is set to **Bill Group**, in the **Customer 360° View** screen.
2. In the **Search Results** section, click the **View** (🔍) icon corresponding to the bill group whose pricing details you want to view.

The **Person** tab appears in the **Customer 360° Information** screen.

3. Click the **Pricing** tab.

The **Pricing** tab appears.

4. Click the **Broadcast** (📡) icon in the **Bill Group ASO Policy Information** zone, corresponding to the **Bill Group Information** column, whose bill group details you want to view.

The **Bill Group ASO Policy Pricing Rules** zone is displayed.

5. Click the **Add** link in the upper right corner of the **Bill Group ASO Policy Pricing Rules** zone.

The **Pricing Rule** screen appears. It contains the following sections:

- **Main** - This section contains the following fields:

Field Name	Field Description	Mandatory (Yes or No)
Person Name	Displays the person name.	Not applicable
Person Type	Displays the person type.	Not applicable
Pricing Rule Type	Used to indicate the pricing rule type. The valid values are: <ul style="list-style-type: none"> <li>• Aggregate Stop-Loss (ASL) Pricing Rule</li> <li>• Claim Pricing Rule</li> <li>• Discount Arrangement Pricing Rule</li> <li>• Retention Type Claim Based Pricing Rule</li> <li>• Retention Type Enrollment Based Pricing Rule</li> <li>• Specific Stop-Loss (SSL) Pricing Rule</li> </ul> <p><b>Note:</b> Select the <b>Retention Type Claim Based Pricing Rule</b> option, as the pricing rule type.</p>	Yes <p><b>Note:</b> If the pricing rule type is not selected then the application displays an error message.</p>
Pricing Group	Used to indicate the pricing group for the bill group. <p><b>Note:</b> You must select a pricing group for the bill group on which the retention type claim based pricing rule is to be defined.</p>	Yes
Policy Status	Used to indicate the policy status for the bill group. The valid values are: <ul style="list-style-type: none"> <li>• In Force/Active</li> <li>• Post Runout</li> <li>• Runout</li> </ul>	Yes (Conditional) <p><b>Note:</b> Policy Status is required once the Pricing Rule Type is selected.</p>

6. Select the appropriate fields in the **Main** section.

7. Click **OK**.

The **Retention Type Claim Based Pricing Rule** screen appears. It contains the following sections:



- **Main** - This section contains the following fields:

Field Name	Field Description	Mandatory (Yes or No)
Price Item	Used to indicate the price item for which you want to define the pricing. The valid value are: <ul style="list-style-type: none"> <li>• Admin Fee</li> </ul>	Yes
Pricing Start Date	Used to specify the start date from when the pricing will be effective for the price item.	Yes (Conditional) <b>Note:</b> Pricing Start Date should be entered if Pricing End Date has been mentioned.
Pricing End Date	Used to specify the end date till when the pricing will be effective for the price item.	No
Rate Option	Used to specify the rate option for the price item. The valid value are: <ul style="list-style-type: none"> <li>• Flat Dollar Per Claim - Agg Daily</li> </ul>	Yes
Pricing Group Rule Code	Displays the code of the pricing group rule.	Not applicable
Description	Displays the description of the pricing group rule.	Not applicable
Price Item Parameter	Used to specify multiple price item parameters based on which you want to determine the price item utilization. <b>Note:</b> The Search (🔍) icon does appear corresponding to this field. On clicking the <b>Search</b> icon, the <b>Price Item Parameters</b> screen appears.	No
Parameter Value	Used to specify multiple price item parameter values based on which you want to determine the price item utilization. <b>Note:</b> The Search (🔍) icon does appear corresponding to this field. On clicking the <b>Search</b> icon, the <b>Parameter Value Search</b> screen appears.	No
Fee	Used to specify the fee for the price item parameter.	No

- **Characteristics** - Used to define the characteristics for the Retention Type Claim Based Pricing Rule for a Bill Group Using a Pricing Group.

8. Add the required details in the main and characteristics section.

9. Click **Save**.

The retention type claim based pricing rule for a bill group using a pricing group is defined.

**Note:**

If the approval workflow group setting is set as **Active** for the bill group, for which the retention type claim based pricing rule is defined then an approval transaction is created for that particular bill group. The retention type claim based pricing rule for a bill group using a pricing group is defined, once the approval transaction is approved.

**Related Topics**

For more information on...	See...
How to define characteristics for a retention type claim based pricing rule for a bill group using pricing group.	<a href="#">Defining Characteristics for a Retention Type Claim Based Pricing Rule for a Bill Group Using a Pricing Group</a> on page 2482

## Defining Characteristics for a Retention Type Claim Based Pricing Rule for a Bill Group Using a Pricing Group

**Prerequisites**

To define characteristics for a retention type claim based pricing rule for a bill group using a pricing group, you should have:

- Characteristic types defined in the application (where the characteristic entity is set to **Pricing Rule**)

**Procedure**

To define characteristics for a retention type claim based pricing rule for a bill group using a pricing group:

1. Ensure that the **Characteristics** section is expanded when you are defining or editing a retention type claim based pricing rule for a bill group

The **Characteristics** section contains the following columns in a grid:

Column Name	Column Description	Mandatory (Yes or No)
Effective Date	Used to specify from when the pricing rule will be effective.	Yes
Characteristic Type	Used to indicate the characteristic type. The valid values are: <ul style="list-style-type: none"> <li>Eligible for Billing</li> </ul> <div style="border: 1px solid black; padding: 5px; margin-top: 10px;"> <b>Note:</b> The list includes only those characteristic types where the characteristic entity is set to <b>Pricing Rule Type</b>. </div>	Yes (Conditional) <div style="border: 1px solid black; padding: 5px; margin-top: 10px;"> <b>Note:</b> This field is required when you are defining a characteristic for retention type claim based pricing rule for a bill group using a pricing group. </div>
Characteristic Value	Used to specify the value for the characteristic type. <div style="border: 1px solid black; padding: 5px; margin-top: 10px;"> <b>Note:</b> If you select a predefined characteristic type, the <b>Search</b>  icon appears corresponding to the <b>Characteristic Value</b> field. On clicking the <b>Search</b> icon, the <b>Predefined Characteristic Search</b> window appears. On specifying the value for a predefined characteristic type, the description of the characteristic value appears corresponding to the <b>Characteristic Value</b> field. </div>	Yes (Conditional) <div style="border: 1px solid black; padding: 5px; margin-top: 10px;"> <b>Note:</b> This field is required when you are defining a characteristic for retention type claim based pricing rule for a bill group using a pricing group. </div>

2. Enter the required details in the **Characteristics** section.
3. If you want to define more than one characteristic, click the **Add**  icon and then repeat step 2.

**Note:** However, if you want to remove a characteristic, click the **Delete**  icon corresponding to the characteristic.

4. Click **Save**.

The characteristics are defined for the retention type claim based pricing rule for a bill group using a pricing group.

### Related Topics

For more information on...	See...
How to define a retention type claim based pricing rule for a bill group using a pricing group.	<a href="#">Defining a Retention Type Claim Based Pricing Rule for a Bill Group Using a Pricing Group</a> on page 2479

## Viewing a Retention Type Claim Based Pricing Rule of a Parent Customer

### Procedure

To view a retention type claim based pricing rule for a parent customer:

1. Search for a parent customer whose pricing details you want to view in the **Customer 360° View** screen.

2. In the **Search Results** section, click the **View**  icon corresponding to the parent customer whose pricing details you want to view.

The **Person** tab appears in the **Customer 360° Information** screen appears.

3. Click the **Pricing** tab.

The **Pricing** tab appears.

4. In the **Parent Customer Pricing Rules** zone, click the link in the **Pricing Rule Information** column corresponding to the pricing rule type whose details you want to view.

The **Pricing Rule** screen appears. It contains the following zone:

- **Retention Type Claim Based** – Displays Retention Type Claim Based Pricing Rule of a Parent. It contains the following sections:
  - **Main** – Displays the basic details about the retention type claim based pricing rule of a parent customer.
  - **Price Item Parameters** – Displays the price item parameters defined for the retention type claim based pricing rule of a parent customer.
  - **Characteristics** – Displays the characteristics defined for the retention type claim based pricing rule of a parent customer.

5. View the basic details of a retention type claim based pricing rule of a parent customer in the **Main** section.

6. View the price item parameters of a retention type claim based pricing rule of a parent customer in the **Price Item Parameters** section.

7. View the characteristics of a retention type claim based pricing rule of a parent customer in the **Characteristics** section.



### Related Topics

For more information on...	See...
<b>Customer 360° Information – Pricing</b> tab	<a href="#">Customer 360° Information - Pricing</a> on page 229

## Viewing a Retention Type Claim Based Pricing Rule of a Bill Group

### Procedure

To view a retention type claim based pricing rule of a bill group:

1. Search for a bill group in the **Customer 360° View** screen.
2. In the **Search Results** section, click the **View** () icon corresponding to the bill group whose pricing details you want to view.  
The **Person** tab appears in the **Customer 360° Information** screen.
3. Click the **Pricing** tab.  
The **Pricing** tab appears.
4. Click the **Broadcast** () icon in the **Bill Group ASO Policy Information** zone, corresponding to the **Bill Group Information** column, whose bill group details you want to view.  
The **Bill Group ASO Policy Pricing Rules** zone appears.
5. In the **Bill Group ASO Policy Pricing Rules** zone, click the link in the **Pricing Rule Information** column corresponding to the pricing rule type whose details you want to view.  
The **Pricing Rule** screen appears. It contains the following zone:

- **Retention Type Claim Based** – Displays Retention Type Claim Based Pricing Rule of a Bill Group. It contains the following sections:
  - **Main** – Displays the basic details about the retention type claim based pricing rule of a bill group.
  - **Price Item Parameters** – Displays the price item parameters defined for the retention type claim based pricing rule of a bill group.
  - **Characteristics** – Displays the characteristics defined for the retention type claim based pricing rule of a bill group.
- 6. View the basic details of a retention type claim based pricing rule of a bill group in the **Main** section.
- 7. View the price item parameters of a retention type claim based pricing rule of a bill group in the **Price Item Parameters** section.
- 8. View the characteristics of a retention type claim based pricing rule of a bill group in the **Characteristics** section.

### Related Topics

For more information on...	See...
<b>Customer 360° Information – Pricing</b> tab	<a href="#">Customer 360° Information - Pricing</a> on page 229

## Retention Type Enrollment Based Pricing

Some of the charges, such as stop-loss premium, administrative fees, etc. are typically calculated based on the number of enrollments. In addition, the ASL limit can also be based on the number of enrollments for the month. These charges can be calculated using the retention type enrollment based pricing rules.

You can define a retention type enrollment based pricing rule at the parent customer and bill group levels. The retention type enrollment based pricing rule at the bill group level takes precedence over the retention type enrollment based pricing rule at the parent customer level. You can define retention type enrollment based pricing rules for parent customers and bill groups from the **Customer 360° Information** screen. You can define a retention type enrollment

based pricing rule using a retention type enrollment based pricing rule type. It is the retention type enrollment based pricing rule type which helps the system to determine:

- Business object using which the retention type enrollment based pricing rule should be created in the system.
- Whether it is the primary pricing rule type.

**Note:** You must select the **Primary** option while defining a retention type enrollment based pricing rule type. On selecting the **Primary** option, the **Related Pricing Rule Types** and **Transaction Field Mapping** sections appear in the **Retention Type Enrollment Based Pricing Rule Type** screen. At present, the system does not allow you to define any pricing rule type which inherits the attributes from the retention type enrollment based pricing rule type.

- Transaction fields from where the data for retention type enrollment based processing should be retrieved.
- Algorithm which should be triggered while validating a transaction.

**Note:** An algorithm type for validating a transaction is not shipped from the product. You need to create a custom algorithm type, if required.

- Algorithms which should be triggered while deriving bill group, account, and price item for a transaction.

**Note:** You must create an algorithm using the **C1\_TXNBGDRV** algorithm type and attach it to the **Bill Group Derivation** system event. Similarly, you must create an algorithm using the **C1\_ACCPRIDRV** algorithm type and attach it to the **Account and Price Item Derivation** system event.

- Algorithm which should be triggered while determining the bill after date.

**Note:** You must create an algorithm using the **C1\_BAFTDRV** algorithm type and attach it to the **Bill After Date Determination** system event. The **C1\_BAFTDRV** algorithm sets the bill after date to the end date of the aggregation schedule which is specified in the respective rate option. For example, if the aggregation schedule is monthly, the bill after date is set to the last day of the month.

- Post-processing algorithm which should be triggered once the retention type enrollment based pricing rule is derived.

**Note:** A post-processing algorithm type is not shipped from the product. You need to create a custom algorithm type, if required.

- Price items for which you can define retention type enrollment based pricing rules using the retention type enrollment based pricing rule type.
- Rate options that you can use while defining the pricing for a price item.
- Different type of account to which the price item should be billed based on the specified priority.
- Price item parameters which you can use while defining retention type enrollment based pricing rules.
- Additional information, such as:
  - Whether the price items included in the retention type enrollment based pricing rule type are used while accumulating specific stop-loss and aggregate stop-loss.
  - Retroactivity indicator which helps to determine whether the enrollment transaction is retro or non-retro transaction.

Once a retention type enrollment based pricing rule type is defined, you can create retention type enrollment based pricing rules using the retention type enrollment based pricing rule type. While defining a retention type enrollment based pricing rule for a parent customer and bill group, you need to specify the following:

- Price item for which you want to define the pricing.
- Pricing date range during which the pricing is effective.
- Rate option which you want to use while defining the retention type enrollment based pricing.

- Whether you want to exempt the retrospective transactions while calculating retention type enrollment based fees.
- Price item parameters based on which you want to define the pricing.

**Note:** You can only use those price item parameters which are included in the respective retention type enrollment based pricing rule type.

- Price item parameters based on which you want to define the pricing.

**Note:** You can only use those price item parameters which are included in the respective retention type enrollment based pricing rule type.

- Flat fee which you want to charge for a price item and price item parameters combination.

The system enables you to define different flat fee for different set of price item parameters combination. For example, you can define one flat fee for the enrollment transactions where health coverage class is set to Medical and health coverage tier is set to Family and another flat fee for the enrollment transactions where health coverage class is set to Dental and health coverage tier is set to Employee.

Once a retention type enrollment based pricing rule is defined for a parent customer and bill group, the system creates one price assignment for each set of price item parameters combination, one price list, and one price list assignment.

## Defining a Retention Type Enrollment Based Pricing Rule Type

### Prerequisites

To define a retention type retention based pricing rule type, you should have:

- Business Object **C1-PrcRuleTypRetEnrollBased** defined for retention type enrollment based pricing rule type.
- Business Object **C1-PricingRuleRetTypeEnroll** defined for pricing rule.
- Pricing rule type category for the retention type enrollment defined in the application.

### Procedure

To define a retention type retention based pricing rule type:

1. Click the **Admin** link in the **Application** toolbar.  
A list appears.
2. From the **Admin** menu, select **P** and then click **Pricing Rule Type**.  
A sub-menu appears.
3. Click the **Add** option from the **Pricing Rule Type** sub-menu.

The **Select Business Object** screen appears. It contains the following field:

Field Name	Field Description	Mandatory (Yes or No)
Pricing Rule Type Business Object	Used to indicate the business object using which you want to create the retention type enrollment based pricing rule type.  <b>Note:</b> You can create a retention type enrollment based pricing rule type using the <b>Claim Pricing Rule Type</b> business object.	Yes

**Tip:** Alternatively, you can access this screen by clicking the **Add** button in the **Page Title** area of the **Pricing Rule Type** screen.

4. Select the **Retention Type Claim Based Pricing Rule Type** business object.

5. Click **OK**.

The **Retention Type Claim Based Pricing Rule Type** screen appears. It contains the following sections:

- **Main** – Used to specify basic details about the retention type enrollment based pricing rule type.
- **Related Pricing Rule Types** – Used to define the pricing rule types which are related to the enrollment based parent pricing rule type.
- **Transaction Field Mapping** – Used to specify the transaction related data mapped to the enrollment based pricing rule type.
- **Algorithms** – Used to define the algorithms used for the enrollment based pricing rule type.
- **Additional Data** – Used to specify the additional information about the enrollment based pricing rule type.
- **Price Items** – Used to define the price items assigned to the enrollment based pricing rule type.
- **Price Item Parameters** – Used to define the price item parameters in the enrollment based pricing rule type.
- **Characteristics** – Used to define the characteristics for the enrollment based pricing rule type.
- **Enrollment-Specific Additional Data** – Used to specify the enrollment specific additional data.

The **Main** section contains the following fields:

Field Name	Field Description	Mandatory (Yes or No)
Pricing Rule Type	Used to specify the pricing rule type.	Yes
Description	Used to specify the description for the pricing rule type.	Yes
Detailed Description	Used to specify additional information about the pricing rule type.	No
Related Transaction Business Object	Used to indicate the pricing rule business object. The valid values are: <ul style="list-style-type: none"> <li>• Aggregate Stop-Loss (ASL) Pricing Rule</li> <li>• Claim Pricing Rule</li> <li>• Discount Arrangement Pricing Rule</li> <li>• Retention Type Claim Based Pricing Rule</li> <li>• Retention Type Enrollment Based Pricing Rule</li> <li>• Specific Stop-Loss (SSL) Pricing Rule</li> </ul>	Yes
Business Object	Indicate the retention type enrollment based pricing rule type business object for the claim.	Not applicable
Status	Used to indicate the status of the pricing rule type. The valid values are: <ul style="list-style-type: none"> <li>• Active</li> <li>• Inactive</li> </ul>	
Primary	Used to select the checkbox if the pricing rule type is primary.	No

Field Name	Field Description	Mandatory (Yes or No)
Pricing Rule Type Category	Used to indicate the pricing rule type category for the pricing rule type. The valid values are: <ul style="list-style-type: none"> <li>Aggregate Stop-Loss</li> <li>Claim</li> <li>Discount Arrangement</li> <li>Retention Type Claim Based</li> <li>Retention Type Enrollment Based</li> <li>Specific Stop-Loss</li> </ul>	Yes

- Enter the required details in the **Main** section.
- Add the related pricing rule types in the primary pricing rule type, if required.

**Note: Related Pricing Rule Types** section appears only when the pricing rule type is primary.

- Define the transaction field mapping in the primary pricing rule type, if required.

**Note: Transaction Field Mapping** section appears only when the pricing rule type is primary.

- Associate algorithms with the enrollment based pricing rule type, if required.
- Define additional data for the enrollment based pricing rule type, if required.
- Add pricing items in the enrollment based pricing rule type, if required.
- Add price item parameters in the enrollment based pricing rule type, if required.
- Define characteristics for the enrollment based pricing rule type, if required.
- Add the enrollment-specific data, if required.
- Click **Save**.

The retention type enrollment based pricing rule type is defined.

### **Related Topics**

For more information on...	See...
<b>Pricing Rule Type</b> screen	<a href="#">Pricing Rule Type</a> on page 2343
How to add the related pricing rule types in the primary pricing rule type	<a href="#">Adding Related Pricing Rule Types in a Primary Pricing Rule Type</a>
How to define the transaction field mapping in the primary pricing rule type	<a href="#">Defining Transaction Field Mapping in a Primary Pricing Rule Type</a>
How to associate algorithms with the pricing rule type	<a href="#">Associating Algorithms with a Pricing Rule Type</a>
How to define additional data for the pricing rule type	<a href="#">Defining Additional Data for a Pricing Rule Type</a>
How to add pricing items in the pricing rule type	<a href="#">Adding Price Items in a Pricing Rule Type</a>
How to add price item parameters in the pricing rule type	<a href="#">Adding a Price Item Parameter in a Pricing Rule Type</a>



For more information on...	See...
How to define characteristics for the pricing rule type	<a href="#">Defining Characteristics for a Pricing Rule Type</a>
How to add claim templates in the claim pricing rule type	<a href="#">Adding Claim Templates in a Claim Pricing Rule Type</a> on page 2359
How to add the claim-specific data in the pricing rule type	<a href="#">Adding the Claim-Specific Data in a Pricing Rule Type</a> on page 2360

## Adding the Enrollment Specific Data in a Pricing Rule Type

### Prerequisites

To add enrollment specific data in a pricing rule type, you should have:

- Pricing rule types defined in the application.
- Account and Price Item Derivation Algorithm defined in the application.
- Bill Group Derivation Algorithm defined in the application.

### Procedure

To add enrollment specific data in a pricing rule type in a pricing rule type:

1. Ensure that the **Enrollment-Specific Additional Data** section is expanded when you are adding enrollment specific data for a primary pricing rule type.

The **Enrollment-Specific Additional Data** section contains the following fields:

Field Name	Field Description	Mandatory (Yes or No)
Retroactivity Indicator Value	Used to specify that retroactivity indicator value should not be a part of enrollment based pricing rule type.  <b>Note:</b> Set the retroactivity indicator value to <b>R</b> if the field should be excluded from enrollment based pricing rule types.	No

2. Enter the required details in the **Enrollment-Specific Additional Data** section.
3. Click **Save**.

The enrollment-specific data has been added in the pricing rule type.

### Related Topics

For more information on...	See...
Defining a retention type enrollment based pricing rule type	<a href="#">Defining a Retention Type Enrollment Based Pricing Rule Type</a> on page 2486

## Editing a Retention Type Enrollment Based Pricing Rule Type

### Prerequisites

To edit the retention type enrollment based pricing rule type, you should have:

- Business Object **C1-PricingRuleRetTypeEnroll** defined for the retention type enrollment based pricing rule type.
- Business Object **C1-PrcRuleTypRetEnrollBased** defined for the retention type enrollment based pricing rule type.

- Pricing rule type category for retention type enrollment based pricing rule type defined in the application

### **Procedure**

To edit a retention type enrollment based pricing rule type:

1. Click the **Admin** link in the **Application** toolbar.  
A list appears.
2. From the **Admin** menu, select **P** and then click **Pricing Rule Type**.  
A sub-menu appears.
3. Click the **Search** option from the **Pricing Rule Type** sub-menu.  
The **Pricing Rule Type** screen appears.
4. In the **Pricing Rule Type List** zone, click the **Edit** (✎) icon in the **Edit** column corresponding to the pricing rule type for claim whose details you want to edit.

The **Retention Type Enrollment Based Pricing Rule Type** screen appears. It contains the following sections:

- **Main** – Used to specify basic details about the retention type enrollment based pricing rule type.
- **Related Pricing Rule Types** – Used to define the pricing rule types which are related to the retention type enrollment based pricing rule type.
- **Transaction Field Mapping** – Used to specify the transaction related data mapped to the pricing rule type.
- **Algorithms** – Used to define the algorithms used for the retention type enrollment based pricing rule type.
- **Additional Data** – Used to specify the additional information about the retention type enrollment based pricing rule type.
- **Price Items** – Used to define the price items assigned to the retention type enrollment based pricing rule type.
- **Price Item Parameters** – Used to define the price item parameters in the retention type enrollment based pricing rule type.
- **Characteristics** – Used to define the characteristics for the retention type enrollment based pricing rule type.
- **Claim Templates** – Used to define the pricing rule type for the retention type enrollment based pricing rule type.
- **Claim-Specific Additional Data** – Used to specify the retention type enrollment based specific additional data.

The **Main** section contains the following fields:

<b>Field Name</b>	<b>Field Description</b>	<b>Mandatory (Yes or No)</b>
Pricing Rule Type	Displays the pricing rule type.	Not applicable
Description	Used to specify the description for the pricing rule type.	Yes
Detailed Description	Used to specify additional information about the pricing rule type.	No

Field Name	Field Description	Mandatory (Yes or No)
Related Transaction Business Object	Used to indicate the retention type claim based pricing rule type business object. The valid values are: <ul style="list-style-type: none"> <li>• Claim Pricing Rule</li> <li>• Aggregate Stop-Loss (ASL) Pricing Rule</li> <li>• Specific Stop-Loss (SSL) Pricing Rule</li> <li>• Retention Type Claim Based Pricing Rule</li> <li>• Retention Type Enrollment Based Pricing Rule</li> </ul>	Yes
Business Object	Displays the retention type enrollment based pricing rule type business object for retention type claim.	Not applicable
Status	Used to indicate the status of the retention type enrollment based pricing rule type. The valid values are: <ul style="list-style-type: none"> <li>• Active</li> <li>• Inactive</li> </ul>	
Primary	Used to select the checkbox if the retention type enrollment based pricing rule type is primary.	No
Pricing Rule Type Category	Used to indicate the pricing rule type category for the retention type enrollment based pricing rule type. The valid values are: <ul style="list-style-type: none"> <li>• Aggregate Stop-Loss</li> <li>• Claim</li> <li>• Discounted Agreement</li> <li>• Retention Type Claim Based</li> <li>• Retention Type Enrollment Based</li> <li>• Specific Stop-Loss</li> </ul>	Yes

**Tip:** Alternatively, you can click the **Edit** button in the **Pricing Rule Type** zone to edit the pricing rule type for retention type enrollment.

5. Modify the details in the **Main** section, if required.
6. Add, edit, or remove the related pricing rule types in the retention type enrollment based pricing rule type, if required.
7. Modify the transaction field mapping in the retention type enrollment based pricing rule type, if required.
8. Add, edit, or remove algorithms with the retention type enrollment based pricing rule type, if required.
9. Modify the additional data for the retention type enrollment based pricing rule type, if required.
10. Add, edit, or remove pricing items in the retention type enrollment based pricing rule type, if required.
11. Add, edit, or remove price item parameters in the retention type enrollment based pricing rule type, if required.
12. Add, edit, or remove characteristics for the retention type enrollment based pricing rule type, if required.

13. Modify the enrollment-specific data in the retention type enrollment based pricing rule type, if required.

14. Click **Save**.

The changes made to the Retention Type Enrollment Based Pricing Rule Type are saved.

#### Related Topics

For more information on...	See...
<b>Pricing Rule Type</b> screen	<a href="#">Pricing Rule Type</a> on page 2343
<b>Pricing Rule Type List</b> zone	<a href="#">Pricing Rule Type List</a> on page 2344
<b>Pricing Rule Type</b> zone	<a href="#">Pricing Rule Type</a> on page 2347

## Deleting a Retention Type Enrollment Based Pricing Rule Type

### Procedure

To delete a retention type enrollment based pricing rule type:

1. Click the **Admin** link in the **Application** toolbar.

A list appears.

2. From the **Admin** menu, select **P** and then click **Pricing Rule Type**.

A sub-menu appears.

3. Click the **Search** option from the **Pricing Rule Type** sub-menu.

The **Pricing Rule Type** screen appears.

4. In the **Pricing Rule Type List** zone, click the **Delete** (🗑️) icon in the **Delete** column corresponding to the retention type enrollment based pricing rule type that you want to delete.

A message appears confirming whether you want to delete the retention type enrollment based pricing rule type.

**Note:** You can delete a retention type enrollment based pricing rule type only when it is not yet used in the system.

**Tip:** Alternatively, you can delete a retention type enrollment based pricing rule type by clicking the **Delete** button in the **Pricing Rule Type** zone.

5. Click **OK**.

The retention type enrollment based pricing rule type is deleted.

#### Related Topics

For more information on...	See...
<b>Pricing Rule Type</b> screen	<a href="#">Pricing Rule Type</a> on page 2343
<b>Pricing Rule Type List</b> zone	<a href="#">Pricing Rule Type List</a> on page 2344
<b>Pricing Rule Type</b> zone	<a href="#">Pricing Rule Type</a> on page 2347

## Viewing the Retention Type Enrollment Based Pricing Rule Type Details

### Procedure

To view the details of a retention type enrollment based pricing rule type:

1. Click the **Admin** link in the **Application** toolbar.

A list appears.

- From the **Admin** menu, select **P** and then click **Pricing Rule Type**.

A sub-menu appears.

- Click the **Search** option from the **Pricing Rule Type** sub-menu.

The **Pricing Rule Type** screen appears.

- In the **Pricing Rule Type List** zone, click the **Broadcast**  icon corresponding to the retention type enrollment based pricing rule type whose details you want to view.

The **Pricing Rule Type** zone appears.

- View the details of the retention type enrollment based pricing rule type in the **Pricing Rule Type** zone.

### **Related Topics**

<b>For more information on...</b>	<b>See...</b>
<b>Pricing Rule Type</b> screen	<a href="#">Pricing Rule Type</a> on page 2343
<b>Pricing Rule Type List</b> zone	<a href="#">Pricing Rule Type List</a> on page 2344
<b>Pricing Rule Type</b> zone	<a href="#">Pricing Rule Type</a> on page 2347

## **Defining a Retention Type Enrollment Based Pricing Rule for a Parent Customer**

### **Prerequisites**

To define a retention type enrollment based pricing rule for a parent customer, you should have:

- Business Object **C1-PricingRule** defined for the pricing rule.
- Business Object **C1-PrcRuleTypRetEnrollBased** defined for retention type enrollment based pricing rule type.
- Algorithms **C1-APPTXNBAS** defined for retention type enrollment based pricing rule type.

**Note:** A custom algorithm type must be created to validate a transaction.

### **Procedure**

To define a retention type enrollment based pricing rule for a parent customer:

- Search for a parent customer in the **Customer 360° View** screen.  
The **Search Result** screen appears.
- In the **Search Results** section, click the **View**  icon corresponding to the parent customer whose pricing details you want to view.

The **Person** tab appears in the **Customer 360° Information** screen.

- Click the **Pricing** tab.  
The **Pricing** tab appears.
- Click the **Add** link in the upper-right corner of the **Parent Customer Pricing Rules** zone.

The **Pricing Rule** screen appears. It contains the following fields:

<b>Field Name</b>	<b>Field Description</b>	<b>Mandatory (Yes or No)</b>
Person Name	Displays the person name.	Not applicable
Person Type	Displays the person type.	Not applicable

Field Name	Field Description	Mandatory (Yes or No)
Pricing Rule Type	Used to indicate the pricing rule type. The valid values are: <ul style="list-style-type: none"> <li>Retention Type Enrollment Based Pricing Rule</li> </ul>	Yes  <b>Note:</b> If the pricing rule type is not selected then the application displays an error message.

- Select the required pricing rule type in the respective field.
- Click **OK**.







The **Retention Type Enrollment Based Pricing Rule** screen appears. It contains the following sections:

- Customer Information** - Displays information about the parent customer for whom you are defining the retention type enrollment based pricing rule. It contains the following fields:

Field Name	Field Description
Parent Customer Information	Indicates the parent customer for whom you are defining the retention type enrollment based pricing rule.
Pricing Rule Type	Indicates the pricing rule type using which you are defining the retention type enrollment based pricing rule.

- Main** - This section contains the following fields:

Field Name	Field Description	Mandatory (Yes or No)
Price Item	Used to indicate the price item for which you want to define the pricing. The valid value are: <ul style="list-style-type: none"> <li>Administrative Services Fees</li> <li>Administrative Services Fees (No Mandatory Parameters)</li> <li>AS_RET_ENRB</li> <li>Consultant Oversight Fees</li> </ul>	Yes
Pricing Start Date	Used to specify the start date from when the pricing will be effective for the price item.  <b>Note:</b> The pricing start date cannot be later than the pricing end date.	Yes (Conditional)  <b>Note:</b> Pricing Start Date should be entered if Pricing End Date has been mentioned.
Pricing End Date	Used to specify the end date till when the retention type enrollment based pricing will be effective for the price item.  <b>Note:</b> The pricing end date cannot be earlier than the pricing start date.	No

Field Name	Field Description	Mandatory (Yes or No)															
Rate Option	<p>Used to specify the rate option for the price item. The valid values are:</p> <ul style="list-style-type: none"> <li>• Flat Dollar Per Claim - Agg Daily</li> <li>• Retention - Aggregate Monthly</li> <li>• Claims</li> <li>• Percentage of Claim - Agg Daily</li> <li>• Flat Dollar Per Claim - Agg Daily</li> </ul> <p>On selecting an option from the <b>Rate Option</b> field, following fields appear in a grid:</p> <table border="1" data-bbox="558 642 1227 1969"> <thead> <tr> <th data-bbox="558 642 695 758">Field Name</th> <th data-bbox="695 642 1081 758">Field Description</th> <th data-bbox="1081 642 1227 758">Mandatory (Yes or No)</th> </tr> </thead> <tbody> <tr> <td data-bbox="558 758 695 905">Price Item Parameter</td> <td data-bbox="695 758 1081 905">Used to specify multiple price item parameters based on which you want to determine the price item utilization.</td> <td data-bbox="1081 758 1227 905">No</td> </tr> <tr> <td data-bbox="558 905 695 1367"></td> <td data-bbox="695 905 1081 1367"> <p><b>Note:</b></p> <p>The Search  icon appears corresponding to the <b>Price Item Parameter</b> field. On clicking the <b>Search</b> icon, the <b>Price Item Parameter Search</b> screen appears.</p> <p>On specifying the price item, the description of the price item appears corresponding to the <b>Price Item Parameter</b> field.</p> </td> <td data-bbox="1081 905 1227 1367"></td> </tr> <tr> <td data-bbox="558 1367 695 1514">Parameter Value</td> <td data-bbox="695 1367 1081 1514">Used to specify multiple price item parameter values based on which you want to determine the price item utilization.</td> <td data-bbox="1081 1367 1227 1514">No</td> </tr> <tr> <td data-bbox="558 1514 695 1969"></td> <td data-bbox="695 1514 1081 1969"> <p><b>Note:</b></p> <p>The Search  icon appears corresponding to the <b>Parameter Value</b> field. On clicking the <b>Search</b> icon, the <b>Predefined Parameter Value Search</b> screen appears.</p> <p>On specifying the price item, the description of the price item appears corresponding to the <b>Parameter Value Search</b> field.</p> </td> <td data-bbox="1081 1514 1227 1969"></td> </tr> </tbody> </table>	Field Name	Field Description	Mandatory (Yes or No)	Price Item Parameter	Used to specify multiple price item parameters based on which you want to determine the price item utilization.	No		<p><b>Note:</b></p> <p>The Search  icon appears corresponding to the <b>Price Item Parameter</b> field. On clicking the <b>Search</b> icon, the <b>Price Item Parameter Search</b> screen appears.</p> <p>On specifying the price item, the description of the price item appears corresponding to the <b>Price Item Parameter</b> field.</p>		Parameter Value	Used to specify multiple price item parameter values based on which you want to determine the price item utilization.	No		<p><b>Note:</b></p> <p>The Search  icon appears corresponding to the <b>Parameter Value</b> field. On clicking the <b>Search</b> icon, the <b>Predefined Parameter Value Search</b> screen appears.</p> <p>On specifying the price item, the description of the price item appears corresponding to the <b>Parameter Value Search</b> field.</p>		Yes
Field Name	Field Description	Mandatory (Yes or No)															
Price Item Parameter	Used to specify multiple price item parameters based on which you want to determine the price item utilization.	No															
	<p><b>Note:</b></p> <p>The Search  icon appears corresponding to the <b>Price Item Parameter</b> field. On clicking the <b>Search</b> icon, the <b>Price Item Parameter Search</b> screen appears.</p> <p>On specifying the price item, the description of the price item appears corresponding to the <b>Price Item Parameter</b> field.</p>																
Parameter Value	Used to specify multiple price item parameter values based on which you want to determine the price item utilization.	No															
	<p><b>Note:</b></p> <p>The Search  icon appears corresponding to the <b>Parameter Value</b> field. On clicking the <b>Search</b> icon, the <b>Predefined Parameter Value Search</b> screen appears.</p> <p>On specifying the price item, the description of the price item appears corresponding to the <b>Parameter Value Search</b> field.</p>																

Field Name	Field Description	Mandatory (Yes or No)
	<p><b>Note:</b></p> <p>If you want to define more than one price item parameter to the price item in a retention type enrollment based pricing rule type, click the <b>Add</b> (+) icon.</p> <p>However, if you want to remove a price item parameter from the price item in a retention type enrollment based pricing rule type, click the <b>Delete</b> (🗑️) icon corresponding to the <b>Price Item Parameter</b> field.</p>	
Exempt Retro Transactions	Used to indicate that retro transactions should not be considered for calculation purposes.	No
Fee	Used to specify the fee for the price item parameter.	No

- **Characteristics** - Used to define the characteristics for the retention type enrollment based pricing rule for a parent customer.

7. Add the required details in the main and characteristics section.

8. Click **Save**.

The retention type enrollment based pricing rule for a parent customer is defined.

<p><b>Note:</b></p> <p>If the approval workflow group setting is set as <b>Active</b> for the parent customer, for whom the retention type enrollment based pricing rule is defined then an approval transaction is created for that particular parent customer. The retention type enrollment based pricing rule for a parent customer is defined, once the approval transaction is approved.</p>
--

### **Related Topics**

For more information on...	See...
How to define characteristics for a retention type enrollment based pricing rule.	<a href="#">Defining Characteristics for a Retention Type Enrollment Based Pricing Rule</a> on page 2496

## **Defining Characteristics for a Retention Type Enrollment Based Pricing Rule**

### **Prerequisites**

To define characteristics for a retention type enrollment based pricing rule, you should have:

- Characteristic types defined in the application (where the characteristic entity is set to **Pricing Rule**)

### **Procedure**

To define characteristics for a retention type claim based pricing rule:

1. Ensure that the **Characteristics** section is expanded when you are defining or editing a retention type enrollment based pricing rule.

The **Characteristics** section contains the following columns in a grid:



Column Name	Column Description	Mandatory (Yes or No)
Effective Date	Used to specify from when the pricing rule will be effective.	Yes
Characteristic Type	Used to indicate the characteristic type. The valid values are: <ul style="list-style-type: none"> <li>Eligible for Billing</li> </ul> <p><b>Note:</b> The list includes only those characteristic types where the characteristic entity is set to <b>Pricing Rule Type</b>.</p>	Yes (Conditional) <p><b>Note:</b> This field is required when you are defining a characteristic for retention type enrollment based pricing rule.</p>
Characteristic Value	Used to specify the value for the characteristic type. <p><b>Note:</b> If you select a predefined characteristic type, the <b>Search</b>  icon appears corresponding to the <b>Characteristic Value</b> field. On clicking the <b>Search</b> icon, the <b>Predefined Characteristic Search</b> window appears.</p> <p>On specifying the value for a predefined characteristic type, the description of the characteristic value appears corresponding to the <b>Characteristic Value</b> field.</p>	Yes (Conditional) <p><b>Note:</b> This field is required when you are defining a characteristic for retention type enrollment based pricing rule.</p>

- Enter the required details in the **Characteristics** section.
- If you want to define more than one characteristic for retention type enrollment based pricing rule, click the **Add**  icon and then repeat step 2.

**Note:** However, if you want to remove a characteristic from retention type enrollment based pricing rule, click the **Delete**  icon corresponding to the characteristic.

- Click **Save**.

The characteristics are defined for the retention type enrollment based pricing rule.

### Related Topics

For more information on...	See...
How to define a retention type enrollment based pricing rule for a parent customer	<a href="#">Defining a Retention Type Enrollment Based Pricing Rule for a Parent Customer</a> on page 2493

## Editing a Retention Type Enrollment Based Pricing Rule of a Parent Customer

### Prerequisites

To edit a retention type enrollment based pricing rule of a parent customer, you should have:

- Business Object **C1-PricingRule** defined for the pricing rule.
- Business Object **C1-PrcRuleTypRetEnrollBased** defined for retention type enrollment based pricing rule type.
- Algorithms **C1-APPTXNBAS** defined for retention type enrollment based pricing rule type.

**Note:** A custom algorithm type must be created to validate a transaction.

**Procedure**

To edit a retention type enrollment based pricing rule of a parent customer:

1. Search for a parent customer in the **Customer 360° View** screen.
2. In the **Search Results** section, click the **View** () icon corresponding to the parent customer whose pricing details you want to view.

The **Person** tab appears in the **Customer 360° Information** screen.

3. Click the **Pricing** tab.

The **Pricing** tab appears.

4. In the **Parent Customer Pricing Rules** zone, click the **Edit** () icon in the **Edit** column corresponding to the retention type enrollment based pricing rule, whose details you want to edit.

The **Retention Type Enrollment Based Pricing Rule** screen appears. It contains the following zones:

- **Customer Information** - Displays the basic information about the customer. It contains the following fields:

Column Name	Column Description
Parent Customer Information	Displays the parent name.
Pricing Rule Type	Displays the pricing rule type that is chosen to define the retention type claim based pricing rule of a parent customer.

- **Main** - This section contains the following fields:

Field Name	Field Description	Mandatory (Yes or No)
Price Item	Indicates the price item for which you want to define the pricing.	Not applicable
Pricing Start Date	Used to specify the start date from when the pricing will be effective for the price item.	Yes (Conditional) <div style="border: 1px solid black; padding: 2px; margin-top: 5px;"><b>Note:</b> Pricing Start Date should be entered if Pricing End Date has been mentioned.</div>
Pricing End Date	Used to specify the end date till when the pricing will be effective for the price item.	No
Rate Option	Indicates the rate option for the price item.	Not applicable
Exempt Retro Transactions	Used to indicate that retro transactions should not be considered for calculation purposes.	No
Price Item Parameter	Used to specify multiple price item parameters based on which you want to determine the price item utilization. <div style="border: 1px solid black; padding: 2px; margin-top: 5px;"><b>Note:</b> The Search () icon does appear corresponding to this field. On clicking the <b>Search</b> icon, the <b>Price Item Parameters</b> screen appears.</div>	No

Field Name	Field Description	Mandatory (Yes or No)
Parameter Value	Used to specify multiple price item parameter values based on which you want to determine the price item utilization.  <b>Note:</b> The Search  icon does appear corresponding to this field. On clicking the <b>Search</b> icon, the <b>Parameter Value Search</b> screen appears.	No
Fee	Indicates the fee for the price item parameter.	Not applicable

- **Characteristics** - Used to define the characteristics for the Retention Type Enrollment based pricing rule for parent customer. It contains the following fields:

Field Name	Field Description	Mandatory (Yes or No)
Effective Date	Used to specify the effective date from when the characteristic is effective for the retention type enrollment based pricing rule of a parent customer.	No
Characteristic Type	Used to indicate the characteristic type for the retention type enrollment based pricing rule of a parent customer. The valid values are: <ul style="list-style-type: none"> <li>• Eligible for Billing</li> </ul>	No
Characteristic Value	Used to specify the characteristic value for the retention type enrollment based pricing rule of a parent customer.  <b>Note:</b> If you select a predefined characteristic type, the <b>Search</b>  icon appears corresponding to the Characteristic Value field. On clicking the <b>Search</b> icon, the Predefined Characteristic Search window appears. On specifying the value for a predefined characteristic type, the description of the characteristic value appears corresponding to the Characteristic Value field.	No

5. Click **Save**.

**Note:**  
If the approval workflow group setting is set as **Active** for the parent customer, for which the retention type enrollment based pricing rule is defined then an approval transaction is created for that particular parent customer. The retention type enrollment based pricing rule for a parent customer is defined, once the approval transaction is approved.

6. Click **OK**

The retention type enrollment based pricing rule of a parent customer is edited.

## Deleting a Retention Type Enrollment Based Pricing Rule of a Parent Customer

### Procedure

To delete a retention type enrollment based pricing rule of a parent customer:

1. Search for a parent customer in the **Customer 360° View** screen.

2. In the **Search Results** section, click the **View** () icon corresponding to the parent customer whose pricing details you want to view.

The **Person** tab in the **Customer 360° Information** screen appears.

3. Click the **Pricing** tab.

The **Pricing** tab appears.

4. In the **Parent Customer Pricing Rules** zone, click the **Delete** () icon in the **Delete** column corresponding to the retention type enrollment based pricing rule that you want to delete.

A message appears confirming whether you want to delete the retention type enrollment based pricing rule.

**Note:** You can delete a retention type enrollment based pricing rule only when it is not yet used in the system.

5. Click **OK**.

The retention type enrollment based pricing rule of a parent customer is deleted.

### Related Topics

For more information on...	See...
How to search for a parent customer	<a href="#">Searching for a Person</a> on page 185
<b>Parent Customer Pricing Rules</b> zone	<a href="#">Parent Customer Pricing Rules</a> on page 231

## Defining a Retention Type Enrollment Based Pricing Rule for a Bill Group

### Prerequisites

To define a retention type enrollment based pricing rule for a bill group, you should have:

- Business Object **C1-PricingRule** and **C1-PricingRuleType**, and **C1-PricingGroup** defined for the pricing rule.
- Business Object **C1-PolicyBOSStatusReason** defined for the policy status.
- Business Object **C1-PrcRuleTypRetEnrollBased** defined for retention type enrollment based pricing rule type.
- Algorithms **C1-APPTXNBAS** defined for retention type enrollment based pricing rule type.

**Note:** A custom algorithm type must be created to validate a transaction.

### Procedure

To define a retention type enrollment based pricing rule for a bill group:

1. Search for the Administrative Services Only (ASO) person, whose person type is set to **Bill Group**, in the **Customer 360° View** screen.

2. In the **Search Results** section, click the **View** () icon corresponding to the person whose pricing details you want to view.

The **Person** tab appears in the **Customer 360° Information** screen.

3. Click the **Pricing** tab.

The **Pricing** tab appears.

4. Click the **Broadcast** () icon in the **Bill Group ASO Policy Information** zone, corresponding to the **Bill Group Information** column, whose bill group details you want to view.

The **Bill Group ASO Policy Pricing Rules** zone is displayed.

5. Click the **Add** link in the upper right corner of the **Bill Group ASO Policy Pricing Rules** zone.

The **Pricing Rule** screen appears. It contains the following fields:

Field Name	Field Description	Mandatory (Yes or No)
Person Name	Indicates the name of the parent customer.	Not applicable
Person Type	Indicates the type of the parent customer. <b>Note:</b> If you are defining the pricing rule type for the parent customer, then the person type will be <b>Parent Customer</b> .	Not applicable
Pricing Rule Type	Used to indicate the pricing rule type using which you want to create a retention type enrollment based pricing rule. <b>Note:</b> Select the <b>Retention Type Enrollment Based Pricing Rule</b> option, as the pricing rule type.	Yes <b>Note:</b> If the pricing rule type is not selected then the application displays an error message.
Pricing Group	Used to indicate the pricing group for the bill group. <b>Note:</b> Select the pricing group option only when the retention type enrollment based pricing rule has to be defined for a bill group using the pricing group.	No
Policy Status	Used to indicate the policy status for the bill group. The valid values are: <ul style="list-style-type: none"> <li>• In Force/Active</li> <li>• Post Runout</li> <li>• Runout</li> </ul>	Yes (Conditional) <b>Note:</b> Policy Status is required once the Pricing Rule Type is selected.



6. Select the appropriate fields in the **Main** section.

7. Click **OK**.

The **Retention Type Enrollment Based Pricing Rule** screen appears. It contains the following sections:

- **Main** - This section contains the following fields:

Field Name	Field Description	Mandatory (Yes or No)
Price Item	Used to indicate the price item for which you want to define the pricing. The valid value are: <ul style="list-style-type: none"> <li>• Administrative Services Fees</li> <li>• Administrative Services Fees (No Mandatory Parameters)</li> <li>• AS_RET_ENRB</li> <li>• Consultant Oversight Fees</li> </ul>	Yes

Field Name	Field Description	Mandatory (Yes or No)
Pricing Start Date	Used to specify the start date from when the pricing will be effective for the price item.	Yes (Conditional) <b>Note:</b> Pricing Start Date should be entered if Pricing End Date has been mentioned.
Pricing End Date	Used to specify the end date till when the pricing will be effective for the price item. <b>Note:</b> If the pricing end date is mentioned, once the price parameters and fees have been already entered, then the price parameter value and fee field values are reset.	No
Rate Option	Used to specify the rate option for the price item. The valid values are: <ul style="list-style-type: none"> <li>Flat Dollar Per Claim - Agg Daily</li> <li>Retention - Aggregate Monthly</li> <li>Claims</li> <li>Percentage of Claim - Agg Daily</li> <li>Flat Dollar Per Claim - Agg Daily</li> </ul>	Yes
Exempt Retro Transactions	Used to indicate that retro transactions should not be considered for calculation purposes.	No
Pricing Group Rule Code	Displays the name of the pricing group rule code. <b>Note:</b> If a particular bill group has a single or multiple pricing group rule codes then all of those pricing group rule codes are shown along with their respective description.	No
Price Item Parameter	Used to specify multiple price item parameters based on which you want to determine the price item utilization. <b>Note:</b> The Search  icon does appear corresponding to this field. On clicking the <b>Search</b> icon, the <b>Price Item Parameters</b> screen appears.	No
Parameter Value	Used to specify multiple price item parameter values based on which you want to determine the price item utilization. <b>Note:</b> The Search  icon does appear corresponding to this field. On clicking the <b>Search</b> icon, the <b>Parameter Value Search</b> screen appears.	No
Fee	Used to specify the fee for the price item parameter.	No

- **Characteristics** - Used to define the characteristics for the retention type enrollment based pricing rule for a bill group.
8. Add the required details in the main and characteristics section.
  9. Click **Save**.

The retention type enrollment based pricing rule for a bill group is defined.

**Note:**

If the approval workflow group setting is set as **Active** for the bill group, for which the retention type enrollment based pricing rule is defined then an approval transaction is created for that particular bill group. The retention type enrollment based pricing rule for a bill group is defined, once the approval transaction is approved.

**Related Topics**

For more information on...	See...
How to define characteristics for a retention type enrollment based pricing rule for a bill group.	<a href="#">Defining Characteristics for a Retention Type Enrollment Based Pricing Rule</a> on page 2503

## Defining Characteristics for a Retention Type Enrollment Based Pricing Rule

**Prerequisites**

To define characteristics for a retention type enrollment based pricing rule, you should have:

- Characteristic types defined in the application (where the characteristic entity is set to **Pricing Rule**)

**Procedure**

To define characteristics for a retention type enrollment based pricing rule:

1. Ensure that the **Characteristics** section is expanded when you are defining or editing a retention type claim based pricing rule.

The **Characteristics** section contains the following columns in a grid:

Column Name	Column Description	Mandatory (Yes or No)
Effective Date	Used to specify from when the pricing rule will be effective.	Yes
Characteristic Type	Used to indicate the characteristic type. The valid values are: <ul style="list-style-type: none"> <li>• Eligible for Billing</li> </ul> <p><b>Note:</b> The list includes only those characteristic types where the characteristic entity is set to <b>Pricing Rule Type</b>.</p>	Yes (Conditional) <p><b>Note:</b> This field is required when you are defining a characteristic for retention type enrollment based pricing rule.</p>

Column Name	Column Description	Mandatory (Yes or No)
Characteristic Value	<p>Used to specify the value for the characteristic type.</p> <p><b>Note:</b></p> <p>If you select a predefined characteristic type, the <b>Search</b>  icon appears corresponding to the <b>Characteristic Value</b> field. On clicking the <b>Search</b> icon, the <b>Predefined Characteristic Search</b> window appears.</p> <p>On specifying the value for a predefined characteristic type, the description of the characteristic value appears corresponding to the <b>Characteristic Value</b> field.</p>	<p>Yes (Conditional)</p> <p><b>Note:</b> This field is required when you are defining a characteristic for retention type enrollment based pricing rule.</p>

- Enter the required details in the **Characteristics** section.
- If you want to define more than one characteristic for retention type enrollment based pricing rule, click the **Add**  icon and then repeat step 2.

**Note:** However, if you want to remove a characteristic from retention type enrollment based pricing rule, click the **Delete**  icon corresponding to the characteristic.

- Click **Save**.

The characteristics are defined for the retention type enrollment based pricing rule.

#### Related Topics

For more information on...	See...
How to define a retention type enrollment based pricing rule for a bill group	<a href="#">Defining a Retention Type Enrollment Based Pricing Rule for a Bill Group</a> on page 2500

## Editing a Retention Type Enrollment Based Pricing Rule of a Bill Group

### Prerequisites

To edit a retention type enrollment based pricing rule of a bill group, you should have:

- Business Object **C1-PricingRule** defined for the pricing rule.
- Business Object **C1-PrcRuleTypRetEnrollBased** defined for retention type enrollment based pricing rule type.
- Algorithms **C1-APPTXNBAS** defined for retention type enrollment based pricing rule type.

**Note:** A custom algorithm type must be created to validate a transaction.

### Procedure

To edit a retention type enrollment based pricing rule of a bill group:

- Search for a bill group in the **Customer 360° View** screen.
- In the **Search Results** section, click the **View**  icon corresponding to the bill group whose pricing details you want to view.

The **Person** tab appears in the **Customer 360° Information** screen.

- Click the **Pricing** tab.

The **Pricing** tab appears.



4. Click the **Broadcast**  icon in the **Bill Group ASO Policy Information** zone, corresponding to the **Bill Group Information** column, whose bill group details you want to view.

The **Bill Group ASO Policy Pricing Rules** zone appears.

5. Click the **Edit**  icon in the **Bill Group ASO Policy Pricing Rules** zone, corresponding to the **Pricing Rule Type** column, whose details you want to edit.



The **Retention Type Enrollment Based Pricing Rule** screen appears. It contains the following zones:



- **Customer Information** - Displays the basic information about the customer. It contains the following fields:

Column Name	Column Description
Bill Group Information	Displays the bill group name.
Policy Start Date	Displays the date from when the policy is effective.
Policy End Date	Displays the date till when the policy is effective.
Policy Status	Displays the status of the policy.
Pricing Group	Displays the pricing group information.
Pricing Rule Type	Displays the pricing rule type that is chosen to define the retention type claim based pricing rule of a bill group.

- **Main** - This section contains the following fields:



Field Name	Field Description	Mandatory (Yes or No)
Price Item	Indicates the price item for which you want to define the pricing.	Not applicable
Pricing Start Date	Used to specify the start date from when the pricing will be effective for the price item.	Yes (Conditional) <b>Note:</b> Pricing Start Date should be entered if Pricing End Date has been mentioned.
Pricing End Date	Used to specify the end date till when the pricing will be effective for the price item.	No
Rate Option	Indicates the rate option for the price item.	Not applicable
Exempt Retro Transactions	Used to indicate that retro transactions should not be considered for calculation purposes.	No
Pricing Group Rule Code	Displays the name of the pricing group rule code. <b>Note:</b> If a particular bill group has a single or multiple pricing group rule codes then all of those pricing group rule codes are shown along with their respective description.	Not applicable

Field Name	Field Description	Mandatory (Yes or No)
Price Item Parameter	Used to specify multiple price item parameters based on which you want to determine the price item utilization.  <b>Note:</b> The Search  icon does appear corresponding to this field. On clicking the <b>Search</b> icon, the <b>Price Item Parameters</b> screen appears.	No
Parameter Value	Used to specify multiple price item parameter values based on which you want to determine the price item utilization.  <b>Note:</b> The Search  icon does appear corresponding to this field. On clicking the <b>Search</b> icon, the <b>Parameter Value Search</b> screen appears.	No
Fee	Indicates the fee for the price item parameter.	Not applicable

**Note:** If you want to define more than one price item parameter information, click the **Add**  icon. However, if you want to remove more than one price item or price item bundle, click the **Delete**  icon corresponding to the price item parameter.

- **Characteristics** - Used to define the characteristics for the retention type claim based pricing rule for parent customer. It contains the following fields:

Field Name	Field Description	Mandatory (Yes or No)
Effective Date	Used to specify the effective date from when the characteristic is effective for the retention type claim based pricing rule of a bill group.	No
Characteristic Type	Used to indicate the characteristic type for the retention type claim based pricing rule of a bill group. The valid values are: <ul style="list-style-type: none"> <li>• Eligible for Billing</li> </ul>	No
Characteristic Value	Used to specify the characteristic value for the retention type claim based pricing rule of a bill group.  <b>Note:</b> If you select a predefined characteristic type, the <b>Search</b>  icon appears corresponding to the Characteristic Value field. On clicking the <b>Search</b> icon, the Predefined Characteristic Search window appears. On specifying the value for a predefined characteristic type, the description of the characteristic value appears corresponding to the Characteristic Value field.	No

**Note:** If you want to define more than one characteristic, click the **Add**  icon. However, if you want to remove more than one characteristic, click the **Delete**  icon corresponding to the characteristic.

6. Click **Save**.

**Note:**

If the approval workflow group setting is set as **Active** for the bill group, for which the retention type enrollment based pricing rule is defined then an approval transaction is created for that particular bill group. The retention type enrollment based pricing rule for a bill group is defined, once the approval transaction is approved.

7. Click **OK**

The retention type enrollment based pricing rule of a bill group is edited.

## Deleting a Retention Type Enrollment Based Pricing Rule of a Bill Group

### Procedure

To delete a retention type enrollment based pricing rule of a bill group:

1. Search for the Administrative Services Only (ASO) person, whose person type is set to **Bill Group**, in the **Customer 360° View** screen.
2. In the **Search Results** section, click the **View** () icon corresponding to the person whose pricing details you want to view.

The **Person** tab appears in the **Customer 360° Information** screen.

3. Click the **Pricing** tab.

The **Pricing** tab appears.

4. Click the **Broadcast** () icon in the **Bill Group ASO Policy Information** zone, corresponding to the **Bill Group Information** column, whose bill group details you want to view.

The **Bill Group ASO Policy Pricing Rules** zone appears.

5. Click the **Delete** () icon in the **Bill Group ASO Policy Pricing Rules** zone, corresponding to the **Pricing Rule Type** column, whose details you want to edit.

A message appears confirming whether you want to delete the retention type enrollment based pricing rule of a bill group.

6. Click **OK**.

The retention type enrollment based pricing rule of a bill group is deleted.

### Related Topics

For more information on...	See...
How to define retention type enrollment based pricing rule for a bill group	<a href="#">Defining a Retention Type Enrollment Based Pricing Rule for a Bill Group</a> on page 2500

## Defining a Retention Type Enrollment Based Pricing Rule for a Bill Group Using a Pricing Group

### Procedure

To define a retention type enrollment based pricing rule for a bill group using pricing group:

1. Search for the Administrative Services Only (ASO) person, whose person type is set to **Bill Group**, in the **Customer 360° View** screen.

- In the **Search Results** section, click the **View** () icon corresponding to the person whose pricing details you want to view.

The **Person** tab appears in the **Customer 360° Information** screen.

- Click the **Pricing** tab.

The **Pricing** tab appears.

- Click the **Broadcast** () icon in the **Bill Group ASO Policy Information** zone, corresponding to the **Bill Group Information** column, whose bill group details you want to view.

The **Bill Group ASO Policy Pricing Rules** zone is displayed.

- Click the **Add** link in the upper right corner of the **Bill Group ASO Policy Pricing Rules** zone.

The **Pricing Rule** screen appears. It contains the following sections:

- Main** - This section contains the following fields:

Field Name	Field Description	Mandatory (Yes or No)
Person Name	Displays the person name.	Not applicable
Person Type	Displays the person type.	Not applicable
Pricing Rule Type	Used to indicate the pricing rule type. The valid values are: <ul style="list-style-type: none"> <li>Aggregate Stop-Loss (ASL) Pricing Rule</li> <li>Claim Pricing Rule</li> <li>Discount Arrangement Pricing Rule</li> <li>Retention Type Claim Based Pricing Rule</li> <li>Retention Type Enrollment Based Pricing Rule</li> <li>Specific Stop-Loss (SSL) Pricing Rule</li> </ul> <p><b>Note:</b> Select the <b>Retention Type Enrollment Based Pricing Rule</b> option, as the pricing rule type.</p>	Yes  <b>Note:</b> If the pricing rule type is not selected then the application displays an error message.
Pricing Group	Used to indicate the pricing group for the bill group.  <b>Note:</b> You must select a pricing group for the bill group on which a retention type enrollment based pricing rule is to be defined.	Yes
Policy Status	Used to indicate the policy status for the bill group. The valid values are: <ul style="list-style-type: none"> <li>In Force/Active</li> <li>Post Runout</li> <li>Runout</li> </ul>	Yes (Conditional)  <b>Note:</b> Policy Status is required once the Pricing Rule Type is selected.

- Select the appropriate fields in the **Main** section.



- Click **OK**.

The **Retention Type Enrollment Based Pricing Rule** screen appears. It contains the following sections:

- Main** - This section contains the following fields:

Field Name	Field Description	Mandatory (Yes or No)
Price Item	Used to indicate the price item for which you want to define the pricing. The valid value are: <ul style="list-style-type: none"> <li>Administrative Services Fees</li> <li>Administrative Services Fees (No Mandatory Parameters)</li> <li>AS_RET_ENRB</li> <li>Consultant Oversight Fees</li> </ul>	Yes
Pricing Start Date	Used to specify the start date from when the pricing will be effective for the price item.	Yes (Conditional) <b>Note:</b> Pricing Start Date should be entered if Pricing End Date has been mentioned.
Pricing End Date	Used to specify the end date till when the pricing will be effective for the price item. <b>Note:</b> If the pricing end date is mentioned, once the price parameters and fees have been already entered, then the price parameter value and fee field values are reset.	No
Rate Option	Used to specify the rate option for the price item. The valid values are: <ul style="list-style-type: none"> <li>Flat Dollar Per Claim - Agg Daily</li> <li>Retention - Aggregate Monthly</li> <li>Claims</li> <li>Percentage of Claim - Agg Daily</li> <li>Flat Dollar Per Claim - Agg Daily</li> </ul>	Yes
Exempt Retro Transactions	Used to indicate that retro transactions should not be considered for calculation purposes.	No
Pricing Group Rule Code	Displays the code of the pricing group rule.	Not applicable
Description	Displays the description of the pricing group rule.	Not applicable
Price Item Parameter	Used to specify multiple price item parameters based on which you want to determine the price item utilization. <b>Note:</b> The Search  icon does appear corresponding to this field. On clicking the <b>Search</b> icon, the <b>Price Item Parameters</b> screen appears.	No

Field Name	Field Description	Mandatory (Yes or No)
Parameter Value	Used to specify multiple price item parameter values based on which you want to determine the price item utilization.  <b>Note:</b> The Search  icon does appear corresponding to this field. On clicking the <b>Search</b> icon, the <b>Parameter Value Search</b> screen appears.	No
Fee	Used to specify the fee for the price item parameter.	No

**Note:** If you want to define more than one price item parameter information, click the **Add**  icon. However, if you want to remove more than one price item or price item bundle, click the **Delete**  icon corresponding to the price item parameter.

- **Characteristics** - Used to define the characteristics for the Retention Type Enrollment Based Pricing Rule for a Bill Group Using a Pricing Group.
8. Add the required details in the main and characteristics section.
  9. Click **Save**.

The retention type claim based pricing rule for a bill group using a pricing group is defined.

If the approval workflow group setting is set as **Active** for the bill group, for which the retention type enrollment based pricing rule is defined then an approval transaction is created for that particular bill group. The retention type enrollment based pricing rule for a bill group using a pricing group is defined, once the approval transaction is approved.

### Related Topics

For more information on...	See...
How to define characteristics for a retention type enrollment based pricing rule for a bill group using pricing group.	<a href="#">Defining Characteristics for a Retention Type Enrollment Based Pricing Rule for a Bill Group Using a Pricing Group</a> on page 2510

## Defining Characteristics for a Retention Type Enrollment Based Pricing Rule for a Bill Group Using a Pricing Group

### Prerequisites

To define characteristics for a retention type enrollment based pricing rule for a bill group using a pricing group, you should have:

- Characteristic types defined in the application (where the characteristic entity is set to **Pricing Rule**)

### Procedure

To define characteristics for a retention type enrollment based pricing rule for a bill group using a pricing group:

1. Ensure that the **Characteristics** section is expanded when you are defining or editing a retention type claim based pricing rule for a bill group using a pricing group.

The **Characteristics** section contains the following columns in a grid:

Column Name	Column Description	Mandatory (Yes or No)
Effective Date	Used to specify from when the pricing rule will be effective.	Yes
Characteristic Type	Used to indicate the characteristic type. The valid values are: <ul style="list-style-type: none"> <li>Eligible for Billing</li> </ul> <div style="border: 1px solid black; padding: 5px;"> <p><b>Note:</b> The list includes only those characteristic types where the characteristic entity is set to <b>Pricing Rule Type</b>.</p> </div>	Yes (Conditional) <div style="border: 1px solid black; padding: 5px;"> <p><b>Note:</b> This field is required when you are defining a characteristic for retention type enrollment based pricing rule for a bill group using a pricing group.</p> </div>
Characteristic Value	Used to specify the value for the characteristic type. <div style="border: 1px solid black; padding: 5px;"> <p><b>Note:</b> If you select a predefined characteristic type, the <b>Search</b>  icon appears corresponding to the <b>Characteristic Value</b> field. On clicking the <b>Search</b> icon, the <b>Predefined Characteristic Search</b> window appears.  On specifying the value for a predefined characteristic type, the description of the characteristic value appears corresponding to the <b>Characteristic Value</b> field.</p> </div>	Yes (Conditional) <div style="border: 1px solid black; padding: 5px;"> <p><b>Note:</b> This field is required when you are defining a characteristic for retention type enrollment based pricing rule for a bill group using a pricing group.</p> </div>

- Enter the required details in the **Characteristics** section.
- If you want to define more than one characteristic, click the **Add**  icon and then repeat step 2.

**Note:** However, if you want to remove a characteristic, click the **Delete**  icon corresponding to the characteristic.

- Click **Save**.

The characteristics are defined for the retention type enrollment based pricing rule for a bill group using a pricing group.

### Related Topics

For more information on...	See...
How to define a retention type enrollment based pricing rule for a bill group using a pricing group.	<a href="#">Defining a Retention Type Enrollment Based Pricing Rule for a Bill Group Using a Pricing Group</a> on page 2507

## Viewing a Retention Type Enrollment Based Pricing Rule of a Parent Customer

### Procedure

To view a retention type enrollment based pricing rule for a parent customer:

- Search for a parent customer whose pricing details you want to view in the **Customer 360° View** screen.
- In the **Search Results** section, click the **View**  icon corresponding to the parent customer whose pricing details you want to view.

The **Person** tab appears in the **Customer 360° Information** screen.

3. Click the **Pricing** tab.

The **Pricing** tab appears.

4. In the **Parent Customer Pricing Rules** zone, click the link in the **Pricing Rule Information** column corresponding to the pricing rule type whose details you want to view.

The **Pricing Rule** screen appears. It contains the following zone:

- **Retention Type Enrollment Based** – Displays Retention Type Enrollment Based Pricing Rule of a Parent. It contains the following sections:
  - **Main** – Displays the basic details about the retention type enrollment based pricing rule of a parent customer.
  - **Price Item Parameters** – Displays the price item parameters defined for the retention type enrollment based pricing rule of a parent customer.
  - **Characteristics** – Displays the characteristics defined for the retention type enrollment based pricing rule of a parent customer.
- 5. View the basic details of a retention type enrollment based pricing rule of a parent customer in the **Main** section.
- 6. View the price item parameters of a retention type enrollment based pricing rule of a parent customer in the **Price Item Parameters** section.
- 7. View the characteristics of a retention type enrollment based pricing rule of a parent customer in the **Characteristics** section.

#### Related Topics

For more information on...	See...
Customer 360° Information – Pricing tab	<a href="#">Customer 360° Information - Pricing</a> on page 229

## Viewing a Retention Type Enrollment Based Pricing Rule of a Bill Group

### Procedure

To view a retention type enrollment based pricing rule of a bill group:

1. Search for a bill group in the **Customer 360° View** screen.
2. In the **Search Results** section, click the **View** () icon corresponding to the bill group whose pricing details you want to view.
 

The **Person** tab appears in the **Customer 360° Information** screen.
3. Click the **Pricing** tab.
 

The **Pricing** tab appears.
4. Click the **Broadcast** () icon in the **Bill Group ASO Policy Information** zone, corresponding to the **Bill Group Information** column, whose bill group details you want to view.
 

The **Bill Group ASO Policy Pricing Rules** zone appears.
5. In the **Bill Group ASO Policy Pricing Rules** zone, click the link in the **Pricing Rule Information** column corresponding to the pricing rule type whose details you want to view.
 

The **Pricing Rule** screen appears. It contains the following zone:



- **Retention Type Enrollment Based** – Displays Retention Type Enrollment Based Pricing Rule of a Bill Group. It contains the following sections:
    - **Main** – Displays the basic details about the retention type enrollment based pricing rule of a bill group.
    - **Price Item Parameters** – Displays the price item parameters defined for the retention type enrollment based pricing rule of a bill group.
    - **Characteristics** – Displays the characteristics defined for the retention type enrollment based pricing rule of a bill group.
6. View the basic details of a retention type enrollment based pricing rule of a bill group in the **Main** section.
  7. View the price item parameters of a retention type enrollment based pricing rule of a bill group in the **Price Item Parameters** section.
  8. View the characteristics of a retention type enrollment based pricing rule of a bill group in the **Characteristics** section.

### Related Topics

For more information on...	See...
<b>Customer 360° Information – Pricing</b> tab	<a href="#">Customer 360° Information - Pricing</a> on page 229

## Flat Fee Pricing

---

The Administrative Services Only (ASO) provider would like to charge one-time or recurring flat fee to the self-funded employer. Oracle Revenue Management and Billing enables you to process and bill such one-time and recurring charges to the bill group. The system enables you to define one-time or recurring flat fee for a price item. You can define recurring flat fee based on bill period or frequency. The one-time flat fee, bill period based recurring flat fee, and frequency based recurring flat fee can be defined using the respective flat fee pricing rules. You can only define one-time flat fee, bill period based recurring flat fee, and frequency based recurring flat fee pricing rules for a bill group.

You can define the flat fee pricing rules for bill groups from the **Customer 360° Information** screen. You can define a one-time flat fee, bill period based recurring flat fee, and frequency based recurring flat fee pricing rule using the respective flat fee pricing rule type. It is the flat fee pricing rule type which helps the system to determine:

- Business object using which the flat fee pricing rule should be created in the system.

**Note:** You must not select the **Primary** option while defining a one-time flat fee, bill period based recurring flat fee, and frequency based recurring flat fee pricing rule type.

- Price items for which you can define the flat fee pricing rules.
- Rate options that you can use while defining the pricing for the price item.
- Different type of account to which a price item should be billed based on the specified priority.
- Rule type which indicates the rules that should be executed to determine whether the price item is eligible for billing.
- Additional flat fee specific data, such as:
  - Bill segment cancel reason which you want to use when the one-time or recurring flat fee bill segment is canceled due to change in the flat fee amount.
  - Whether the pricing rule type is defined for one-time flat fee or recurring flat fee.
  - Recurring method which indicates that the system should create recurring flat fee charge based on bill period or frequency. This information is required when you are defining a recurring flat fee pricing rule type.

- Bill period that you can use while defining a bill period based recurring flat fee pricing rule. This information is required when you are defining a bill period based recurring flat fee pricing rule type.

Once a one-time flat fee pricing rule type is defined, you can define one-time flat fee pricing rules using the one-time flat fee pricing rule type. While defining a one-time flat fee pricing rule for a bill group, you need to specify the following:

- The policy status in which the one-time flat fee pricing rule is applicable. Note that you cannot define a one-time flat fee pricing rule for the post runout period of the policy.
- Price item for which you want to create the one-time flat fee billable charge.
- Date which you want to specify as the start and end dates in the one-time flat fee billable charge.
- Billable charge line type using which you want to create the one-time flat fee billable charge.
- Bill after date which you want to stamp on the one-time flat fee billable charge.
- Flat fee amount for which you want to create the one-time flat fee billable charge.
- Override account when you want to create the one-time flat fee billable charge on a particular account. If you do not specify the bill to override account, the system will derive the account using the priority defined for the price item in the one-time flat fee pricing rule type.

Once a bill period based recurring flat fee pricing rule type is defined, you can define bill period based recurring flat fee pricing rules using the bill period based recurring flat fee pricing rule type. While defining a bill period based recurring flat fee pricing rule for a bill group, you need to specify the following:

- The policy status in which the bill period based recurring flat fee pricing rule is applicable. Note that you cannot define a bill period based recurring flat fee pricing rule for the post runout period of the policy.
- Price item for which you want to create the bill period based recurring flat fee billable charge.
- Dates which you want to specify as the start and end dates in the bill period based recurring flat fee billable charge.
- Billable charge line type using which you want to create the bill period based recurring flat fee billable charge.
- Bill period using which the recurring bill segments should be created in the system.
- Flat fee amount for which you want to create the bill period based recurring flat fee billable charge.
- Override account when you want to create the bill period based recurring flat fee billable charge on a particular account. If you do not specify the bill to override account, the system will derive the account using the priority defined for the price item in the bill period based recurring flat fee pricing rule type.

Once a frequency based recurring flat fee pricing rule type is defined, you can define frequency based recurring flat fee pricing rules using the frequency based recurring flat fee pricing rule type. While defining a frequency based recurring flat fee pricing rule for a bill group, you need to specify the following:

- The policy status in which the frequency based recurring flat fee pricing rule is applicable. Note that you cannot define a frequency based recurring flat fee pricing rule for the post runout period of the policy.
- Price item for which you want to create the frequency based recurring flat fee billable charge.
- Dates which you want to specify as the start and end dates in the frequency based recurring flat fee billable charge.
- Billable charge line type using which you want to create the frequency based recurring flat fee billable charge.
- Frequency using which the recurring bill segments should be created in the system.
- Flat fee amount for which you want to create the frequency based recurring flat fee billable charge.
- Override account when you want to create the frequency based recurring flat fee billable charge on a particular account. If you do not specify the bill to override account, the system will derive the account using the priority defined for the price item in the frequency based recurring flat fee pricing rule type.

Once a one-time flat fee, bill period based recurring flat fee, or frequency based recurring flat fee pricing rule is defined for a bill group, the system creates the one-time or recurring flat fee billable charge, respectively. The system does not create any price assignment, price list, or price list assignment in case of flat fee pricing.

## Defining a One-Time Flat Fee Pricing Rule Type

### Prerequisites

To define a one-time flat fee pricing rule type, you should have:

- Business Object **C1-PricingRuleTypeFlatFees** defined for pricing rule type.
- Business Object **C1-PricingRuleFlatFees** defined for pricing rule.
- Pricing rule type category for flat fees defined in the application.

### Procedure

To define a one-time flat fee pricing rule type:

1. Click the **Admin** link in the **Application** toolbar.  
A list appears.
2. From the **Admin** menu, select **P** and then click **Pricing Rule Type**.  
A sub-menu appears.
3. Click the **Add** option from the **Pricing Rule Type** sub-menu.

The **Select Business Object** screen appears. It contains the following field:

Field Name	Field Description	Mandatory (Yes or No)
Pricing Rule Type Business Object	Used to indicate the business object using which you want to create the pricing rule type.  <b>Note:</b> You can create a one-time flat fee pricing rule type using the <b>Flat Fee Pricing Rule Type</b> business object.	Yes

**Tip:** Alternatively, you can access this screen by clicking the **Add** button in the **Page Title** area of the **Pricing Rule Type** screen.

4. Select the **Flat Fee Pricing Rule Type** business object.
5. Click **OK**.

The **Flat Fee Pricing Rule Type** screen appears. It contains the following sections:

- **Main** – Used to specify basic details about the flat fee pricing rule type.
- **Related Pricing Rule Types** – Used to define the pricing rule types which are related to the parent pricing rule type.
- **Transaction Field Mapping** – Used to specify the transaction related data mapped to the pricing rule type
- **Algorithms** – Used to define the algorithms used for the pricing rule type.
- **Additional Data** – Used to specify the additional information about the pricing rule type.
- **Price Items** – Used to define the price items assigned to the pricing rule type.
- **Price Item Parameters** – Used to define the price item parameters in the pricing rule type.
- **Characteristics** – Used to define the characteristics for the pricing rule type.
- **Billable Charge Line Types** – Used to define the pricing rule type for billable charge line type.
- **Flat Fees - Specific Additional Data** – Used to specify the flat fees specific for additional data.

The **Main** section contains the following fields:

Field Name	Field Description	Mandatory (Yes or No)
Pricing Rule Type	Used to specify the pricing rule type.	Yes
Description	Used to specify the description for the pricing rule type.	Yes
Detailed Description	Used to specify additional information about the pricing rule type.	No
Pricing Rule Business Object	Used to indicate the pricing rule business object. The valid values are: <ul style="list-style-type: none"> <li>• Claim Pricing Rule</li> <li>• Aggregate Stop-Loss (ASL) Pricing Rule</li> <li>• Specific Stop-Loss (SSL) Pricing Rule</li> <li>• Retention Type Claim Based Pricing Rule</li> <li>• Retention Type Enrollment Based Pricing Rule</li> <li>• Flat Fee Pricing Rule</li> </ul>	Yes
Business Object	Indicates the pricing rule type business object for flat fees.	Not applicable
Status	Used to indicate the status of the pricing rule type. The valid values are: <ul style="list-style-type: none"> <li>• Active</li> <li>• Inactive</li> </ul>	Yes
Primary	Used to select the checkbox if the pricing rule type is primary.  <div style="border: 1px solid black; padding: 2px;"> <b>Note:</b> This field is not enabled for selection if the <b>Pricing Rule Type Category</b> is <b>Flat Fees</b>. </div>	No
Pricing Rule Type Category	Used to indicate the pricing rule type category for the pricing rule type. The valid values are: <ul style="list-style-type: none"> <li>• Claim</li> <li>• Aggregate Stop-Loss</li> <li>• Specific Stop-Loss</li> <li>• Retention Type Claim Based</li> <li>• Retention Type Enrollment Based</li> <li>• Flat Fees</li> </ul>	Yes

6. Enter the required details in the **Main** section.
7. Add the related pricing rule types in the primary pricing rule type, if required.

**Note:**

**Related Pricing Rule Types** section appears only when the pricing rule type is primary.  
This section does not appear when the **Pricing Rule Type Category** is **Flat Fees**.

8. Define the transaction field mapping in the primary pricing rule type, if required.

**Note:**

**Transaction Field Mapping** section appears only when the pricing rule type is primary.  
This section does not appear when the **Pricing Rule Type Category** is **Flat Fees**.

9. Associate algorithms with the pricing rule type, if required.
10. Define additional data for the pricing rule type, if required.

**Note:** This section does not appear when the **Pricing Rule Type Category** is **Flat Fees**.

11. Add pricing items in the pricing rule type, if required.
12. Add price item parameters in the pricing rule type, if required.
13. Define characteristics for the pricing rule type, if required.
14. Define billable charge line types in the flat fees pricing rule type, if required.
15. Add the flat fees - specific additional data in the pricing rule type, if required.

**Note:** This section appears only when the **Business Object** is **Flat Fees Pricing Rule Type**.

16. Click **Save**.

The one-time flat fee pricing rule type is defined.

**Related Topics**

<b>For more information on...</b>	<b>See...</b>
<b>Pricing Rule Type</b> screen	<a href="#">Pricing Rule Type</a> on page 2343
How to add the related pricing rule types in the primary pricing rule type	<a href="#">Adding Related Pricing Rule Types in a Primary Pricing Rule Type</a>
How to define the transaction field mapping in the primary pricing rule type	<a href="#">Defining Transaction Field Mapping in a Primary Pricing Rule Type</a>
How to associate algorithms with the pricing rule type	<a href="#">Associating Algorithms with a Pricing Rule Type</a>
How to define additional data for the pricing rule type	<a href="#">Defining Additional Data for a Pricing Rule Type</a>
How to add pricing items in the pricing rule type	<a href="#">Adding Price Items in a Pricing Rule Type</a>
How to add price item parameters in the pricing rule type	<a href="#">Adding a Price Item Parameter in a Pricing Rule Type</a>
How to define characteristics for the pricing rule type	<a href="#">Defining Characteristics for a Pricing Rule Type</a>
How to add the one-time flat fee specific additional data in the pricing rule type	<a href="#">Adding the One-Time Flat Fee Specific Data in a Pricing Rule Type</a> on page 2517

**Adding the One-Time Flat Fee Specific Data in a Pricing Rule Type**

**Procedure**

To add the one-time flat fee specific data in a pricing rule type:

1. Ensure that the **Flat Fees - Specific Additional Data** section is expanded when you are defining or editing a pricing rule type.

The **Flat Fees - Specific Additional Data** section contains the following fields:

Field Name	Field Description	Mandatory (Yes or No)
Bill Segment Cancel Reason	Used to indicate the bill segment cancel reason.	No
Recurring Fee	Used to specify whether the recurring flat fee or one-time flat fee is required.  <b>Note:</b> This field cannot be edited.	No
Recurring Method	Used to indicate whether recurring bill segments must be created at the intervals defined in the bill period or at the set invoice frequency. The valid values are: <ul style="list-style-type: none"> <li>• Bill Period</li> <li>• Frequency</li> </ul> <b>Note:</b> This field appears only when you select the checkbox for <b>Recurring Fee</b> field. This field cannot be edited.	Yes (Conditional)  <b>Note:</b> This field is required when you are specifying whether the recurring flat fee is based on bill period or frequency.

2. Enter the required details in the **Flat Fees - Specific Additional Data** section.
3. Click **Save**.

The Flat Fees - Specific Additional data is added in the pricing rule type.

**Related Topics**

For more information on...	See...
How to define a one-time flat fee pricing rule type	<a href="#">Defining a One-Time Flat Fee Pricing Rule Type</a> on page 2515
How to edit a one-time flat fee pricing rule type	<a href="#">Editing a One-Time Flat Fee Pricing Rule Type</a> on page 2518

**Editing a One-Time Flat Fee Pricing Rule Type****Prerequisites**

To edit a one-time flat fee pricing rule type, you should have:

- Business Object **C1-PricingRuleFlatFees** defined for pricing rule.
- Pricing rule type category for flat fees defined in the application.

**Procedure**

To edit a one-time flat fee pricing rule type:

1. Click the **Admin** link in the **Application** toolbar.  
A list appears.
2. From the **Admin** menu, select **P** and then click **Pricing Rule Type**.  
A sub-menu appears.
3. Click the **Search** option from the **Pricing Rule Type** sub-menu.  
The **Pricing Rule Type** screen appears.
4. In the **Pricing Rule Type List** zone, click the **Edit**  icon in the **Edit** column corresponding to the Pricing rule type whose details you want to edit.

The **Pricing Rule Type** screen appears. It contains the following sections:

- **Main** – Used to specify basic details about the flat fee pricing rule type.
- **Related Pricing Rule Types** – Used to define the pricing rule types which are related to the parent pricing rule type.
- **Transaction Field Mapping** – Used to specify the transaction related data mapped to the pricing rule type
- **Algorithms** – Used to define the algorithms used for the pricing rule type.
- **Additional Data** – Used to specify the additional information about the pricing rule type.
- **Price Items** – Used to define the price items assigned to the pricing rule type.
- **Price Item Parameters** – Used to define the price item parameters in the pricing rule type.
- **Characteristics** – Used to define the characteristics for the pricing rule type.
- **Billable Charge Line Types** – Used to define the pricing rule type for billable charge line type.
- **Flat Fees - Specific Additional Data** – Used to specify the flat fees specific for additional data.

The **Main** section contains the following fields:

Field Name	Field Description	Mandatory (Yes or No)
Pricing Rule Type	Displays the pricing rule type.	Not applicable
Description	Used to specify the description for the pricing rule type.	Yes
Detailed Description	Used to specify additional information about the pricing rule type.	No
Pricing Rule Business Object	Used to indicate the pricing rule business object. The valid values are: <ul style="list-style-type: none"> <li>• Claim Pricing Rule</li> <li>• Aggregate Stop-Loss (ASL) Pricing Rule</li> <li>• Specific Stop-Loss (SSL) Pricing Rule</li> <li>• Retention Type Claim Based Pricing Rule</li> <li>• Retention Type Enrollment Based Pricing Rule</li> <li>• Flat Fee Pricing Rule</li> </ul>	Yes
Business Object	Indicates the pricing rule type business object for flat fees.	Not applicable

Field Name	Field Description	Mandatory (Yes or No)
Status	Used to indicate the status of the pricing rule type. The valid values are: <ul style="list-style-type: none"> <li>Active</li> <li>Inactive</li> </ul>	Yes
Primary	Used to select the checkbox if the pricing rule type is primary.  <div style="border: 1px solid black; padding: 2px;"> <b>Note:</b> This field is not enabled for selection if the <b>Pricing Rule Type Category</b> is <b>Flat Fees</b>. </div>	No
Pricing Rule Type Category	Used to indicate the pricing rule type category for the pricing rule type. The valid values are: <ul style="list-style-type: none"> <li>Claim</li> <li>Aggregate Stop-Loss</li> <li>Specific Stop-Loss</li> <li>Retention Type Claim Based</li> <li>Retention Type Enrollment Based</li> <li>Flat Fees</li> </ul>	Yes

**Tip:** Alternatively, you can edit the details of a one-time flat fees pricing rule type by clicking the **Edit** button in the **Pricing Rule Type** zone.

- Modify the required details in the **Main** section.
- Define, edit or remove related pricing rule types from the primary pricing rule type, if required.

**Note:**

**Related Pricing Rule Types** section appears only when the pricing rule type is primary. This section does not appear when the **Pricing Rule Type Category** is **Flat Fees**.

- Modify the details of transaction field mapping, if required.

**Note:**

**Transaction Field Mapping** section appears only when the pricing rule type is primary. This section does not appear when the **Pricing Rule Type Category** is **Flat Fees**.

- Define, edit or remove algorithms from the pricing rule type, if required.
- Modify additional data for the pricing rule type, if required.

**Note:** This section does not appear when the **Pricing Rule Type Category** is **Flat Fees**.

- Define, edit or remove price items from the pricing rule type, if required.
- Define, edit or remove price items from the pricing rule type, if required.
- Define, edit, or remove characteristics from the pricing rule type, if required.
- Define, edit or remove billable charge line types for the flat fees pricing rule type, if required.



14. Modify flat fees - specific additional data in the pricing rule type, if required.

**Note:** This section appears only when the **Business Object** is **Flat Fees Pricing Rule Type**.

15. Click **Save**.

The changes made to the one-time flat fees pricing rule type are saved.

### **Related Topics**

<b>For more information on...</b>	<b>See...</b>
<b>Pricing Rule Type</b> screen	<a href="#">Pricing Rule Type</a> on page 2343
<b>Pricing Rule Type List</b> zone	<a href="#">Pricing Rule Type List</a> on page 2344
<b>Pricing Rule Type</b> zone	<a href="#">Pricing Rule Type</a> on page 2347
How to add the related pricing rule types in the primary pricing rule type	<a href="#">Adding Related Pricing Rule Types in a Primary Pricing Rule Type</a>
How to define the transaction field mapping in the primary pricing rule type	<a href="#">Defining Transaction Field Mapping in a Primary Pricing Rule Type</a>
How to associate algorithms with the pricing rule type	<a href="#">Associating Algorithms with a Pricing Rule Type</a>
How to define additional data for the pricing rule type	<a href="#">Defining Additional Data for a Pricing Rule Type</a>
How to add pricing items in the pricing rule type	<a href="#">Adding Price Items in a Pricing Rule Type</a>
How to add price item parameters in the pricing rule type	<a href="#">Adding a Price Item Parameter in a Pricing Rule Type</a>
How to define characteristics for the pricing rule type	<a href="#">Defining Characteristics for a Pricing Rule Type</a>
How to add the one-time flat fee specific additional data in the pricing rule type	<a href="#">Adding the One-Time Flat Fee Specific Data in a Pricing Rule Type</a> on page 2517

## **Deleting a One-Time Flat Fee Pricing Rule Type**

### **Procedure**

To delete a one-time flat fee pricing rule type:

1. Click the **Admin** link in the **Application** toolbar.  
A list appears.
2. From the **Admin** menu, select **P** and then click **Pricing Rule Type**.  
A sub-menu appears.
3. Click the **Search** option from the **Pricing Rule Type** sub-menu.  
The **Pricing Rule Type** screen appears.
4. In the **Pricing Rule Type List** zone, click the **Delete** (🗑️) icon in the **Delete** column corresponding to the one-time flat fee pricing rule type that you want to delete.  
A message appears confirming whether you want to delete the one-time flat fee pricing rule type.

**Note:** You can delete a one-time flat fee pricing rule type only when it is not yet used in the system.

**Tip:** Alternatively, you can delete a one-time flat fee pricing rule type by clicking the **Delete** button in the **Pricing Rule Type** zone.

- Click **OK**.

The one-time flat fee pricing rule type is deleted.

### **Related Topics**

<b>For more information on...</b>	<b>See...</b>
<b>Pricing Rule Type</b> screen	<a href="#">Pricing Rule Type</a> on page 2343
<b>Pricing Rule Type List</b> zone	<a href="#">Pricing Rule Type List</a> on page 2344
<b>Pricing Rule Type</b> zone	<a href="#">Pricing Rule Type</a> on page 2347

## **Viewing the One-Time Flat Fee Pricing Rule Type Details**

### **Procedure**

To view the details of a one-time flat fee pricing rule type:

- Click the **Admin** link in the **Application** toolbar.  
A list appears.
- From the **Admin** menu, select **P** and then click **Pricing Rule Type**.  
A sub-menu appears.
- Click the **Search** option from the **Pricing Rule Type** sub-menu.  
The **Pricing Rule Type** screen appears.
- In the **Pricing Rule Type List** zone, click the **Broadcast**  icon corresponding to the one-time flat fee pricing rule type whose details you want to view.  
The **Pricing Rule Type** zone appears.
- View the details of the one-time flat fee pricing rule type in the **Pricing Rule Type** zone.

### **Related Topics**

<b>For more information on...</b>	<b>See...</b>
<b>Pricing Rule Type</b> screen	<a href="#">Pricing Rule Type</a> on page 2343
<b>Pricing Rule Type List</b> zone	<a href="#">Pricing Rule Type List</a> on page 2344
<b>Pricing Rule Type</b> zone	<a href="#">Pricing Rule Type</a> on page 2347

## **Defining a One-Time Flat Fee Pricing Rule for a Bill Group**

### **Prerequisites**

To define a one-time flat fee pricing rule for a bill group, you should have:

- Business Object **C1-PricingRule** defined for pricing rule.
- Business Object **C1-PricingRuleFlatFees** defined for one-time flat fee pricing rule.
- Pricing rule type defined in the application.
- Policy status defined in the application.

- Price item defined in the application.
- Billable Charge Line Type defined in the application.

### **Procedure**

To define a one-time flat fee pricing rule for a bill group:

1. Search for the account, person, or policy whose pricing details you want to view in the **Customer 360° View** screen.
2. In the **Search Results** section, click the **View** () icon corresponding to the account, person, or policy whose pricing details you want to view. The **Account, Person, or Policy** tab in the **Customer 360° Information** screen appears.
3. Click the **Pricing** tab and then click the **Add** link in the upper right corner of the **Bill Group ASO Policy Pricing Rules** zone.

The **Pricing Rule** screen appears. It contains the following fields:

Field Name	Field Description	Mandatory (Yes or No)
Person Name	Displays the person name.	Not applicable
Person Type	Displays the person type.	Not applicable
Pricing Rule Type	Used to indicate the pricing rule type to create the pricing rule.  <b>Note:</b> You can create a one-time flat fee pricing rule using the <b>Pricing Rule Type</b> for flat fees.	Yes
Policy Status	Used to indicate the policy status for pricing rule. The valid values are: <ul style="list-style-type: none"> <li>• In Force/Active</li> <li>• Runout</li> </ul>	Yes

4. Click **OK**.

The **Flat Fee Pricing Rule** screen appears. It contains the following sections:



- **Customer Information** – Displays the customer information for bill group.
- **Main** – Used to specify basic details about the one-time flat fee pricing rule.
- **Characteristics** – Used to define the characteristics for the one-time flat fee pricing rule.

The **Customer Information** section contains the following fields:

Field Name	Field Description	Mandatory (Yes or No)
Bill Group Information	Displays the bill group information.	Not applicable
Policy Start Date	Displays the policy start date.	Not applicable
Policy End Date	Displays the policy end date.	Not applicable
Policy Status	Indicates the policy status for pricing rule. The valid values are: <ul style="list-style-type: none"> <li>• In Force/Active</li> <li>• Runout</li> </ul>	Not applicable

Field Name	Field Description	Mandatory (Yes or No)
Pricing Rule Type	Indicates the pricing rule type.	Not applicable

The **Main** section contains the following fields:

Field Name	Field Description	Mandatory (Yes or No)
Price Item	Used to indicate the price item.	Yes
Charge Date	Used to specify the flat fee charge date.  <b>Note:</b> By default this field displays the policy start date or policy runout start date.	Yes
Billable Charge Line Type	Used to specify the billable charge line type.  <b>Note:</b> On clicking the <b>Search</b>  icon, the <b>Billable Charge Line Type Search</b> window appears. On specifying the billable charge line type, the description of the billable charge line type appears corresponding to the <b>Billable Charge Line Type</b> field.	No
Bill After Date	Used to specify the bills after the specific date.	No
Fee	Used to specify the amount of flat fee.  <b>Note:</b> This field appears only when you select the billable charge line type in the <b>Billable Charge Line Type</b> field.	Yes
Bill To Account Override	Used to specify the account to which the bill is override.  <b>Note:</b> On clicking the <b>Search</b>  icon, the <b>Account Search</b> window appears. On specifying the account, the description of the account appears corresponding to the <b>Bill To Account Override</b> field.	Yes

5. Enter the required details in the **Main** section.
6. Define characteristics for a one-time flat fee pricing rule, if required.
7. Click **Save**.

The one-time flat fee pricing rule for a bill group is defined.

**Note:** A billable charge is created and assigned to the one-time flat fee pricing rule.

### Related Topics

<b>For more information on...</b>	<b>See...</b>
<b>Customer 360° Information – Pricing tab</b>	<i>Customer 360° Information - Pricing</i> on page 229
<b>Bill Group ASO Policy Pricing Rules zone</b>	<i>Bill Group ASO Policy Pricing Rules</i> on page 237
How to define characteristics for a one-time flat fee pricing rule	<i>Defining Characteristics for a One-Time Flat Fee Pricing Rule</i> on page 2525

## Defining Characteristics for a One-Time Flat Fee Pricing Rule

### Prerequisites

To define characteristics for a one-time flat fee pricing rule, you should have:

- Characteristic types defined in the application (where the characteristic entity is set to **Pricing Rule**)

### Procedure

To define characteristics for a one-time flat fee pricing rule:

1. Ensure that the **Characteristics** section is expanded when you are defining or editing a pricing rule.

The **Characteristics** section contains the following columns in a grid:

Column Name	Column Description	Mandatory (Yes or No)
Effective Date	Used to specify the date from when the characteristic is effective for the one-time flat fee pricing rule.	Yes (Conditional) <b>Note:</b> This field is required when you are defining a characteristic for the one-time flat fee pricing rule.
Characteristic Type	Used to indicate the characteristic type. <b>Note:</b> The list includes only those characteristic types where the characteristic entity is set to <b>Pricing Rule</b> .	Yes (Conditional) <b>Note:</b> This field is required when you are defining a characteristic for the one-time flat fee pricing rule.
Characteristic Value	Used to specify the value for the characteristic type. <b>Note:</b> If you select a predefined characteristic type, the <b>Search</b>  icon appears corresponding to the <b>Characteristic Value</b> field. On clicking the <b>Search</b> icon, the <b>Predefined Characteristic Search</b> window appears. On specifying the value for a predefined characteristic type, the description of the characteristic value appears corresponding to the <b>Characteristic Value</b> field.	Yes (Conditional) <b>Note:</b> This field is required when you are defining a characteristic for the one-time flat fee pricing rule.

2. Enter the required details in the **Characteristics** section.
3. If you want to define more than one characteristic for the one-time flat fee pricing rule, click the **Add**  icon and then repeat step 2.

**Note:** However, if you want to remove a characteristic from the one-time flat fee pricing rule, click the **Delete** () icon corresponding to the characteristic.

4. Click **Save**.

The characteristics are defined for the one-time flat fee pricing rule.

### **Related Topics**

<b>For more information on...</b>	<b>See...</b>
How to define a one-time flat fee pricing rule for a bill group	<a href="#">Defining a One-Time Flat Fee Pricing Rule for a Bill Group</a> on page 2522
How to edit the one-time flat fee pricing rule for a bill group	<a href="#">Editing a One-Time Flat Fee Pricing Rule of a Bill Group</a> on page 2526

## **Editing a One-Time Flat Fee Pricing Rule of a Bill Group**

### **Prerequisites**

To edit a one-time flat fee pricing rule of a bill group, you should have:

- Business Object **C1-PricingRuleFlatFees** defined for one-time flat fee pricing rule.

### **Procedure**

To edit a one-time flat fee pricing rule of a bill group:

1. Search for the account, person, or policy whose pricing details you want to view in the **Customer 360° View** screen.
2. In the **Search Results** section, click the **View** () icon corresponding to the account, person, or policy whose pricing details you want to view.

The **Account, Person, or Policy** tab in the **Customer 360° Information** screen appears.

3. Click the **Pricing** tab, in the **Bill Group ASO Policy Pricing Rules** zone click the **Edit** () icon in the **Edit** column corresponding to the pricing rule type for one-time flat fee whose one-time flat fee pricing rule details you want to

The **Flat Fee Pricing Rule** screen appears. It contains the following sections:

- **Customer Information** – Displays the customer information for bill group.
- **Main** – Displays the basic details about the one-time flat fee pricing rule.
- **Characteristics** – Used to define the characteristics for the one-time flat fee pricing rule.

The **Customer Information** section contains the following fields:

<b>Field Name</b>	<b>Field Description</b>	<b>Mandatory (Yes or No)</b>
Bill Group Information	Displays the bill group information.	Not applicable
Policy Start Date	Displays the policy start date.	Not applicable
Policy End Date	Displays the policy end date.	Not applicable
Policy Status	Indicates the policy status for pricing rule. The valid values are: <ul style="list-style-type: none"> <li>• In Force/Active</li> <li>• Runout</li> </ul>	Not applicable

Field Name	Field Description	Mandatory (Yes or No)
Pricing Rule Type	Indicates the pricing rule type.	Not applicable

The **Main** section contains the following fields:

Field Name	Field Description	Mandatory (Yes or No)
Price Item	Indicates the price item.	Not applicable
Charge Date	Used to specify the flat fee charge date.	Yes
Billable Charge Line Type	Displays the billable charge line type.	Not applicable
Bill After Date	Displays the bills after the specific date.	Not applicable
Fee	Used to specify the amount of flat fee.  <b>Note:</b> This field appears only when you have added the billable charge line type in the <b>Billable Charge Line Type</b> field.	Yes
Bill To Account Override	Displays the account to which the bill is override.	Not applicable
Billable Charge Information	Displays the billable charge information.	Not applicable

4. Modify the basic details about the one-time flat fee pricing rule, if required.
5. Add, edit, or remove characteristics for a one-time flat fee pricing rule, if required.
6. Click **Save**.

<p><b>Note:</b> If <b>Fee</b> or <b>Charge Date</b> is modified then it checks whether bill segment is created, and if it is created then,</p> <ul style="list-style-type: none"> <li>• If it is in frozen or pending cancelled status then, <ul style="list-style-type: none"> <li>• Bill segment and billable charge is cancelled and new billable charge is created.</li> </ul> </li> <li>• If it is in any other status other than cancelled then, <ul style="list-style-type: none"> <li>• Bill segment is deleted and existing billable charge billable charge is updated.</li> </ul> </li> </ul> <p><b>Charge Date</b> is set to billable charge start date and end date.</p> <p>When characteristics are updated, billable charge is updated with those characteristics.</p>
--

The changes made to a one-time flat fee pricing rule for a bill group are saved.



### **Related Topics**

For more information on...	See...
<b>Customer 360° Information – Pricing</b> tab	<a href="#">Customer 360° Information - Pricing</a> on page 229
<b>Bill Group ASO Policy Pricing Rules</b> zone	<a href="#">Bill Group ASO Policy Pricing Rules</a> on page 237
How to define characteristics for a one-time flat fee pricing rule	<a href="#">Defining Characteristics for a One-Time Flat Fee Pricing Rule</a> on page 2525

## **Viewing a One-Time Flat Fee Pricing Rule of a Bill Group**

### **Procedure**

To view a one-time flat fee pricing rule of a bill group:

1. Search for the account, person, or policy whose pricing details you want to view in the **Customer 360° View** screen.
2. In the **Search Results** section, click the **View** () icon corresponding to the account, person, or policy whose pricing details you want to view.  
The **Account, Person, or Policy** tab in the **Customer 360° Information** screen appears.
3. Click the **Pricing** tab.
4. In the **Bill Group ASO Policy Information** zone, click the **Broadcast** () icon corresponding to the bill group whose one-time flat fee pricing rule bill group details you want to view.
5. In the **Bill Group ASO Policy Pricing Rules** zone, click the link in the **Pricing Rule Information** column corresponding to the one-time flat fee pricing rule type whose one-time flat fee pricing rule  
The **Pricing Rule** screen appears. It contains the following zone:
  - **Flat Fee** – Displays the pricing rule one-time flat fee details for a bill group. It contains the following sections:
    - **Main** – Displays the basic details about the one-time flat fee pricing rule.
    - **Characteristics** – Displays the characteristics defined for the one-time flat fee pricing rule.
6. View the basic details of one-time flat fee pricing rule in the **Main** section.
7. View the characteristics defined for the one-time flat fee pricing rule in the **Characteristics** section.



#### Related Topics

For more information on...	See...
<b>Customer 360° Information – Pricing</b> tab	<a href="#">Customer 360° Information - Pricing</a> on page 229
<b>Bill Group ASO Policy Pricing Rules</b> zone	<a href="#">Bill Group ASO Policy Pricing Rules</a> on page 237
<b>Pricing Rule</b> screen	<a href="#">Pricing Rule (Used for Viewing)</a> on page 2688
<b>Flat Fee</b> zone	<a href="#">Flat Fee</a> on page 2705

## Deleting a One-Time Flat Fee Pricing Rule of a Bill Group

### Procedure

To delete a one-time flat fee pricing rule of a bill group:

1. Search for the account, person, or policy whose pricing details you want to view in the **Customer 360° View** screen.
2. In the **Search Results** section, click the **View** () icon corresponding to the account, person, or policy whose pricing details you want to view.  
The **Account, Person, or Policy** tab in the **Customer 360° Information** screen appears.
3. Click the **Pricing** tab, in the **Bill Group ASO Policy Pricing Rules** zone, click the **Delete** () icon in the **Delete** column corresponding to the one-time flat fee pricing rule type whose one-time flat fee pricing rule you want to delete.  
A message appears confirming whether you want to delete the one-time flat fee pricing rule.
4. Click **OK**.



**Note:**

If flat fees is not linked to billable charge whose bill segment is in frozen or pending cancelled status then the pricing rule is not deleted.

If bill segment is either not created or is in any other status other than cancelled then delete bill segment, billable charge and pricing rule.

If bill segment is cancelled then billable charge is cancelled and pricing rule is deleted.

The one-time flat fee pricing rule is deleted.

**Related Topics**

For more information on...	See...
Customer 360° Information – Pricing tab	<a href="#">Customer 360° Information - Pricing</a> on page 229
Bill Group ASO Policy Pricing Rules zone	<a href="#">Bill Group ASO Policy Pricing Rules</a> on page 237

**Defining a Bill Period Based Recurring Flat Fee Pricing Rule Type****Prerequisites**

To define a bill period based recurring flat fee pricing rule type, you should have:

- Business Object **C1-PricingRuleTypeFlatFees** defined for pricing rule type.
- Business Object **C1-PricingRuleFlatFees** defined for pricing rule.
- Pricing rule type category for flat fees defined in the application.

**Procedure**

To define a bill period based recurring flat fee pricing rule type:

1. Click the **Admin** link in the **Application** toolbar.  
A list appears.
2. From the **Admin** menu, select **P** and then click **Pricing Rule Type**.  
A sub-menu appears.
3. Click the **Add** option from the **Pricing Rule Type** sub-menu.

The **Select Business Object** screen appears. It contains the following field:

Field Name	Field Description	Mandatory (Yes or No)
Pricing Rule Type Business Object	Used to indicate the business object using which you want to create the pricing rule type.  <b>Note:</b> You can create a bill period based recurring flat fee pricing rule type using the <b>Flat Fee Pricing Rule Type</b> business object.	Yes

**Tip:** Alternatively, you can access this screen by clicking the **Add** button in the **Page Title** area of the **Pricing Rule Type** screen.

4. Select the **Flat Fee Pricing Rule Type** business object.
5. Click **OK**.

The **Flat Fee Pricing Rule Type** screen appears. It contains the following sections:

- **Main** – Used to specify basic details about the flat fee pricing rule type.
- **Related Pricing Rule Types** – Used to define the pricing rule types which are related to the parent pricing rule type.
- **Transaction Field Mapping** – Used to specify the transaction related data mapped to the pricing rule type
- **Algorithms** – Used to define the algorithms used for the pricing rule type.
- **Additional Data** – Used to specify the additional information about the pricing rule type.
- **Price Items** – Used to define the price items assigned to the pricing rule type.
- **Price Item Parameters** – Used to define the price item parameters in the pricing rule type.
- **Characteristics** – Used to define the characteristics for the pricing rule type.
- **Billable Charge Line Types** – Used to define the pricing rule type for billable charge line type.
- **Flat Fees - Specific Additional Data** – Used to specify the flat fees specific for additional data.
  - **Bill Periods** – Used to specify the bill periods for specifying intervals for creating recurring bill segments.

The **Main** section contains the following fields:

Field Name	Field Description	Mandatory (Yes or No)
Pricing Rule Type	Used to specify the pricing rule type.	Yes
Description	Used to specify the description for the pricing rule type.	Yes
Detailed Description	Used to specify additional information about the pricing rule type.	No
Pricing Rule Business Object	Used to indicate the pricing rule business object. The valid values are: <ul style="list-style-type: none"> <li>• Claim Pricing Rule</li> <li>• Aggregate Stop-Loss (ASL) Pricing Rule</li> <li>• Specific Stop-Loss (SSL) Pricing Rule</li> <li>• Retention Type Claim Based Pricing Rule</li> <li>• Retention Type Enrollment Based Pricing Rule</li> <li>• Flat Fee Pricing Rule</li> </ul>	Yes
Business Object	Indicates the pricing rule type business object for flat fees.	Not applicable
Status	Used to indicate the status of the pricing rule type. The valid values are: <ul style="list-style-type: none"> <li>• Active</li> <li>• Inactive</li> </ul>	Yes
Primary	Used to select the checkbox if the pricing rule type is primary. <div style="border: 1px solid black; padding: 2px; margin-top: 5px;"> <p><b>Note:</b> This field is not enabled for selection if the <b>Pricing Rule Type Category</b> is <b>Flat Fees</b>.</p> </div>	No

Field Name	Field Description	Mandatory (Yes or No)
Pricing Rule Type Category	Used to indicate the pricing rule type category for the pricing rule type. The valid values are: <ul style="list-style-type: none"> <li>• Claim</li> <li>• Aggregate Stop-Loss</li> <li>• Specific Stop-Loss</li> <li>• Retention Type Claim Based</li> <li>• Retention Type Enrollment Based</li> <li>• Flat Fees</li> </ul>	Yes

- Enter the required details in the **Main** section.
- Add the related pricing rule types in the primary pricing rule type, if required.

**Note:**

**Related Pricing Rule Types** section appears only when the pricing rule type is primary.  
This section does not appear when the **Pricing Rule Type Category** is **Flat Fees**.

- Define the transaction field mapping in the primary pricing rule type, if required.

**Note:**

**Transaction Field Mapping** section appears only when the pricing rule type is primary.  
This section does not appear when the **Pricing Rule Type Category** is **Flat Fees**.

- Associate algorithms with the pricing rule type, if required.
- Define additional data for the pricing rule type, if required.

**Note:** This section does not appear when the **Pricing Rule Type Category** is **Flat Fees**.

- Add pricing items in the pricing rule type, if required.
- Add price item parameters in the pricing rule type, if required.
- Define characteristics for the pricing rule type, if required.
- Define billable charge line types in the flat fees pricing rule type, if required.
- Add the flat fees - specific additional data in the pricing rule type, if required.

**Note:**

This section appears only when the **Business Object** is **Flat Fees Pricing Rule Type**.  
Add the bill periods in the pricing rule type, if required.

- Click **Save**.

The bill period based recurring flat fee pricing rule type is defined.

**Related Topics**

For more information on...	See...
<b>Pricing Rule Type</b> screen	<a href="#">Pricing Rule Type</a> on page 2343

For more information on...	See...
How to add the related pricing rule types in the primary pricing rule type	<a href="#">Adding Related Pricing Rule Types in a Primary Pricing Rule Type</a>
How to define the transaction field mapping in the primary pricing rule type	<a href="#">Defining Transaction Field Mapping in a Primary Pricing Rule Type</a>
How to associate algorithms with the pricing rule type	<a href="#">Associating Algorithms with a Pricing Rule Type</a>
How to define additional data for the pricing rule type	<a href="#">Defining Additional Data for a Pricing Rule Type</a>
How to add pricing items in the pricing rule type	<a href="#">Adding Price Items in a Pricing Rule Type</a>
How to add price item parameters in the pricing rule type	<a href="#">Adding a Price Item Parameter in a Pricing Rule Type</a>
How to define characteristics for the pricing rule type	<a href="#">Defining Characteristics for a Pricing Rule Type</a>
How to add the recurring flat fee specific data in the pricing rule type	<a href="#">Adding the Recurring Flat Fee Specific Data in a Pricing Rule Type</a> on page 2532

## Adding the Recurring Flat Fee Specific Data in a Pricing Rule Type

### Procedure

To add the recurring flat fee specific data in a pricing rule type:

1. Ensure that the **Flat Fees - Specific Additional Data** section is expanded when you are defining or editing a pricing rule type.

The **Flat Fees - Specific Additional Data** section contains the following fields:

Field Name	Field Description	Mandatory (Yes or No)
Bill Segment Cancel Reason	Used to indicate the bill segment cancel reason.	No
Recurring Fee	Used to specify whether the recurring flat fee or one-time flat fee is required.  <b>Note:</b> This field cannot be edited.	No
Recurring Method	Used to indicate whether recurring bill segments must be created at the intervals defined in the bill period or at the invoice frequency. The valid values are: <ul style="list-style-type: none"> <li>• Bill Period</li> <li>• Frequency</li> </ul> <b>Note:</b> This field appears only when you select the checkbox for <b>Recurring Fee</b> field. This field cannot be edited.	Yes (Conditional)  <b>Note:</b> This field is required when you are specifying whether the recurring flat fee is based on bill period or frequency.

The **Flat Fees - Specific Additional Data** section contains the following sub-section:

The **Bill Periods** sub-section contains the following column in a grid:

Column Name	Column Description	Mandatory (Yes or No)
Bill Period	Used to indicate the bill period that you want to use for specifying the intervals at which the recurring bill segments must be created.	Yes

- Enter the required details in the **Flat Fees - Specific Additional Data** section.
- Enter the details in the **Bill Periods** sub-section, if required.

**Note:** This sub-section appears only when you have selected **Bill Period** as **Recurring Method**.

- Click **Save**.

The Flat Fees - Specific Additional data is added in the pricing rule type.

### **Related Topics**

For more information on...	See...
How to define a bill period based recurring flat fee pricing rule type	<a href="#">Defining a Bill Period Based Recurring Flat Fee Pricing Rule Type</a> on page 2529
How to define a frequency based recurring flat fee pricing rule type	<a href="#">Defining a Frequency Based Recurring Flat Fee Pricing Rule Type</a> on page 2544
How to edit a bill period based recurring flat fee pricing rule type	<a href="#">Editing a Bill Period Based Recurring Flat Fee Pricing Rule Type</a> on page 2533
How to edit a frequency based recurring flat fee pricing rule type	<a href="#">Editing a Frequency Based Recurring Flat Fee Pricing Rule Type</a> on page 2548

## **Editing a Bill Period Based Recurring Flat Fee Pricing Rule Type**

### **Prerequisites**

To edit a bill period based recurring flat fee pricing rule type, you should have:

- Business Object **C1-PricingRuleFlatFees** defined for pricing rule.
- Pricing rule type category for flat fees defined in the application.

### **Procedure**

To edit a bill period based recurring flat fee pricing rule type:

- Click the **Admin** link in the **Application** toolbar.  
A list appears.
- From the **Admin** menu, select **P** and then click **Pricing Rule Type**.  
A sub-menu appears.
- Click the **Search** option from the **Pricing Rule Type** sub-menu.  
The **Pricing Rule Type** screen appears.
- In the **Pricing Rule Type List** zone, click the **Edit** (✎) icon in the **Edit** column corresponding to the Pricing rule type whose details you want to edit.

The **Pricing Rule Type** screen appears. It contains the following sections:

- Main** – Used to specify basic details about the flat fee pricing rule type.

- **Related Pricing Rule Types** – Used to define the pricing rule types which are related to the parent pricing rule type.
- **Transaction Field Mapping** – Used to specify the transaction related data mapped to the pricing rule type
- **Algorithms** – Used to define the algorithms used for the pricing rule type.
- **Additional Data** – Used to specify the additional information about the pricing rule type.
- **Price Items** – Used to define the price items assigned to the pricing rule type.
- **Price Item Parameters** – Used to define the price item parameters in the pricing rule type.
- **Characteristics** – Used to define the characteristics for the pricing rule type.
- **Billable Charge Line Types** – Used to define the pricing rule type for billable charge line type.
- **Flat Fees - Specific Additional Data** – Used to specify the flat fees specific for additional data.
  - **Bill Periods** – Used to specify the bill periods for specifying intervals for creating recurring bill segments.

The **Main** section contains the following fields:

Field Name	Field Description	Mandatory (Yes or No)
Pricing Rule Type	Displays the pricing rule type.	Not applicable
Description	Used to specify the description for the pricing rule type.	Yes
Detailed Description	Used to specify additional information about the pricing rule type.	No
Pricing Rule Business Object	Used to indicate the pricing rule business object. The valid values are: <ul style="list-style-type: none"> <li>• Claim Pricing Rule</li> <li>• Aggregate Stop-Loss (ASL) Pricing Rule</li> <li>• Specific Stop-Loss (SSL) Pricing Rule</li> <li>• Retention Type Claim Based Pricing Rule</li> <li>• Retention Type Enrollment Based Pricing Rule</li> <li>• Flat Fee Pricing Rule</li> </ul>	Yes
Business Object	Indicates the pricing rule type business object for flat fees.	Not applicable
Status	Used to indicate the status of the pricing rule type. The valid values are: <ul style="list-style-type: none"> <li>• Active</li> <li>• Inactive</li> </ul>	Yes
Primary	Used to select the checkbox if the pricing rule type is primary. <div style="border: 1px solid black; padding: 5px; margin-top: 10px;"> <p><b>Note:</b> This field is not enabled for selection if the <b>Pricing Rule Type Category</b> is <b>Flat Fees</b>.</p> </div>	No

Field Name	Field Description	Mandatory (Yes or No)
Pricing Rule Type Category	Used to indicate the pricing rule type category for the pricing rule type. The valid values are: <ul style="list-style-type: none"> <li>• Claim</li> <li>• Aggregate Stop-Loss</li> <li>• Specific Stop-Loss</li> <li>• Retention Type Claim Based</li> <li>• Retention Type Enrollment Based</li> <li>• Flat Fees</li> </ul>	Yes

**Tip:** Alternatively, you can edit the details of a bill period based recurring flat fees pricing rule type by clicking the **Edit** button in the **Pricing Rule Type** zone.

5. Modify the required details in the **Main** section.
6. Define, edit or remove related pricing rule types from the primary pricing rule type, if required.

**Note:**

**Related Pricing Rule Types** section appears only when the pricing rule type is primary.  
This section does not appear when the **Pricing Rule Type Category** is **Flat Fees**.

7. Modify the details of transaction field mapping, if required.

**Note:**

**Transaction Field Mapping** section appears only when the pricing rule type is primary.  
This section does not appear when the **Pricing Rule Type Category** is **Flat Fees**.

8. Define, edit or remove algorithms from the pricing rule type, if required.
9. Modify additional data for the pricing rule type, if required.

**Note:** This section does not appear when the **Pricing Rule Type Category** is **Flat Fees**.

10. Define, edit or remove price items from the pricing rule type, if required.
11. Define, edit or remove price items from the pricing rule type, if required.
12. Define, edit, or remove characteristics from the pricing rule type, if required.
13. Define, edit or remove billable charge line types for the flat fees pricing rule type, if required.
14. Modify flat fees - specific additional data in the pricing rule type, if required.

**Note:**

This section appears only when the **Business Object** is **Flat Fees Pricing Rule Type**.  
Define, edit or remove bill periods from the pricing rule type, if required.

15. Click **Save**.

The changes made to the bill period based recurring flat fee pricing rule type are saved.

### **Related Topics**

For more information on...	See...
<b>Pricing Rule Type</b> screen	<a href="#">Pricing Rule Type</a> on page 2343
<b>Pricing Rule Type List</b> zone	<a href="#">Pricing Rule Type List</a> on page 2344
<b>Pricing Rule Type</b> zone	<a href="#">Pricing Rule Type</a> on page 2347
How to add the related pricing rule types in the primary pricing rule type	<a href="#">Adding Related Pricing Rule Types in a Primary Pricing Rule Type</a>
How to define the transaction field mapping in the primary pricing rule type	<a href="#">Defining Transaction Field Mapping in a Primary Pricing Rule Type</a>
How to associate algorithms with the pricing rule type	<a href="#">Associating Algorithms with a Pricing Rule Type</a>
How to define additional data for the pricing rule type	<a href="#">Defining Additional Data for a Pricing Rule Type</a>
How to add pricing items in the pricing rule type	<a href="#">Adding Price Items in a Pricing Rule Type</a>
How to add price item parameters in the pricing rule type	<a href="#">Adding a Price Item Parameter in a Pricing Rule Type</a>
How to define characteristics for the pricing rule type	<a href="#">Defining Characteristics for a Pricing Rule Type</a>
How to add the recurring flat fee specific data in the pricing rule type	<a href="#">Adding the Recurring Flat Fee Specific Data in a Pricing Rule Type</a> on page 2532

## Deleting a Bill Period Based Recurring Flat Fee Pricing Rule Type

### Procedure

To delete a bill period based recurring flat fee pricing rule type:

1. Click the **Admin** link in the **Application** toolbar.  
A list appears.
2. From the **Admin** menu, select **P** and then click **Pricing Rule Type**.  
A sub-menu appears.
3. Click the **Search** option from the **Pricing Rule Type** sub-menu.  
The **Pricing Rule Type** screen appears.
4. In the **Pricing Rule Type List** zone, click the **Delete** (🗑️) icon in the **Delete** column corresponding to the bill period based recurring flat fee pricing rule type that you want to delete.  
A message appears confirming whether you want to delete the bill period based recurring flat fee pricing rule type.

**Note:** You can delete a bill period based recurring flat fee pricing rule type only when it is not yet used in the system.

**Tip:** Alternatively, you can delete a bill period based recurring flat fee pricing rule type by clicking the **Delete** button in the **Pricing Rule Type** zone.

5. Click **OK**.  
The bill period based recurring flat fee pricing rule type is deleted.

### Related Topics



For more information on...	See...
<b>Pricing Rule Type</b> screen	<a href="#">Pricing Rule Type</a> on page 2343
<b>Pricing Rule Type List</b> zone	<a href="#">Pricing Rule Type List</a> on page 2344
<b>Pricing Rule Type</b> zone	<a href="#">Pricing Rule Type</a> on page 2347

## Viewing the Bill Period Based Recurring Flat Fee Pricing Rule Type Details

### Procedure

To view the details of a bill period based recurring flat fee pricing rule type:

1. Click the **Admin** link in the **Application** toolbar.  
A list appears.
2. From the **Admin** menu, select **P** and then click **Pricing Rule Type**.  
A sub-menu appears.
3. Click the **Search** option from the **Pricing Rule Type** sub-menu.  
The **Pricing Rule Type** screen appears.
4. In the **Pricing Rule Type List** zone, click the **Broadcast**  icon corresponding to the bill period based recurring flat fee pricing rule type whose details you want to view.  
The **Pricing Rule Type** zone appears.
5. View the details of the bill period based recurring flat fee pricing rule type in the **Pricing Rule Type** zone.

### Related Topics

For more information on...	See...
<b>Pricing Rule Type</b> screen	<a href="#">Pricing Rule Type</a> on page 2343
<b>Pricing Rule Type List</b> zone	<a href="#">Pricing Rule Type List</a> on page 2344
<b>Pricing Rule Type</b> zone	<a href="#">Pricing Rule Type</a> on page 2347

## Defining a Bill Period Based Recurring Flat Fee Pricing Rule for a Bill Group

### Prerequisites

To define a bill period based recurring flat fee pricing rule for a bill group, you should have:

- Business Object **C1-PricingRule** defined for pricing rule.
- Business Object **C1-PricingRuleFlatFees** defined for bill period based recurring flat fee pricing rule.
- Pricing rule type defined in the application.
- Policy status defined in the application.
- Price item defined in the application.
- Billable Charge Line Type defined in the application.

### Procedure

To define a bill period based recurring flat fee pricing rule for a bill group:

1. Search for the account, person, or policy whose pricing details you want to view in the **Customer 360° View** screen.

2. In the **Search Results** section, click the **View** () icon corresponding to the account, person, or policy whose pricing details you want to view.

The **Account, Person, or Policy** tab in the **Customer 360° Information** screen appears.

3. Click the **Pricing** tab and then click the **Add** link in the upper right corner of the **Bill Group ASO Policy Pricing Rules** zone.

The **Pricing Rule** screen appears. It contains the following fields:

Field Name	Field Description	Mandatory (Yes or No)
Person Name	Displays the person name.	Not applicable
Person Type	Displays the person type.	Not applicable
Pricing Rule Type	Used to indicate the pricing rule type to create the pricing rule.  <b>Note:</b> You can create a bill period based recurring flat fee pricing rule using the <b>Pricing Rule Type</b> for flat fees.	Yes
Policy Status	Used to indicate the policy status for pricing rule. The valid values are: <ul style="list-style-type: none"> <li>In Force/Active</li> <li>Runout</li> </ul>	Yes

4. Click **OK**.

The **Flat Fee Pricing Rule** screen appears. It contains the following sections:

- Customer Information** – Displays the customer information for bill group.
- Main** – Used to specify basic details about the bill period based recurring flat fee pricing rule.
- Characteristics** – Used to define the characteristics for the bill period based recurring flat fee pricing rule.

The **Customer Information** section contains the following fields:

Field Name	Field Description	Mandatory (Yes or No)
Bill Group Information	Displays the bill group information.	Not applicable
Policy Start Date	Displays the policy start date.	Not applicable
Policy End Date	Displays the policy end date.	Not applicable
Policy Status	Indicates the policy status for pricing rule. The valid values are: <ul style="list-style-type: none"> <li>In Force/Active</li> <li>Runout</li> </ul>	Not applicable
Pricing Rule Type	Indicates the pricing rule type.	Not applicable

The **Main** section contains the following fields:

Field Name	Field Description	Mandatory (Yes or No)
Price Item	Used to indicate the price item.	Yes

Field Name	Field Description	Mandatory (Yes or No)
Charge Start Date	Used to specify the flat fee charge start date.	Yes
Billable Charge Line Type	Used to specify the billable charge line type.  <b>Note:</b> On clicking the <b>Search</b> (🔍) icon, the <b>Billable Charge Line Type Search</b> window appears. On specifying the billable charge line type, the description of the billable charge line type appears corresponding to the <b>Billable Charge Line Type</b> field.	No
Charge End Date	Used to specify the flat fee charge end date.	No
Bill Period	Used to indicate the bill period for flat fee.	Yes
Fee	Used to specify the amount of flat fee.  <b>Note:</b> This field appears only when you select the billable charge line type in the <b>Billable Charge Line Type</b> field.	Yes
Bill To Account Override	Used to specify the account to which the bill is override.  <b>Note:</b> On clicking the <b>Search</b> (🔍) icon, the <b>Account Search</b> window appears. On specifying the account, the description of the account appears corresponding to the <b>Bill To Account Override</b> field.	Yes

5. Enter the required details in the **Main** section.
6. Define characteristics for a bill period based recurring flat fee pricing rule, if required.
7. Click **Save**.

The bill period based recurring flat fee pricing rule for a bill group is defined.

**Note:** A billable charge is created and assigned to the bill period based recurring flat fee pricing rule.

#### Related Topics

For more information on...	See...
<b>Customer 360° Information – Pricing</b> tab	<a href="#">Customer 360° Information - Pricing</a> on page 229
<b>Bill Group ASO Policy Pricing Rules</b> zone	<a href="#">Bill Group ASO Policy Pricing Rules</a> on page 237
How to define characteristics for a bill period based recurring flat fee pricing rule	<a href="#">Defining Characteristics for a Bill Period Based Recurring Flat Fee Pricing Rule</a> on page 2540

## Defining Characteristics for a Bill Period Based Recurring Flat Fee Pricing Rule

### Prerequisites

To define characteristics for a bill period based recurring flat fee pricing rule, you should have:

- Characteristic types defined in the application (where the characteristic entity is set to **Pricing Rule**)

### Procedure

To define characteristics for a bill period based recurring flat fee pricing rule:

1. Ensure that the **Characteristics** section is expanded when you are defining or editing a pricing rule.

The **Characteristics** section contains the following columns in a grid:

Column Name	Column Description	Mandatory (Yes or No)
Effective Date	Used to specify the date from when the characteristic is effective for the bill period based recurring flat fee pricing rule.	Yes (Conditional)  <b>Note:</b> This field is required when you are defining a characteristic for the bill period based recurring flat fee pricing rule.
Characteristic Type	Used to indicate the characteristic type.  <b>Note:</b> The list includes only those characteristic types where the characteristic entity is set to <b>Pricing Rule</b> .	Yes (Conditional)  <b>Note:</b> This field is required when you are defining a characteristic for the bill period based recurring flat fee pricing rule.
Characteristic Value	Used to specify the value for the characteristic type.  <b>Note:</b> If you select a predefined characteristic type, the <b>Search</b>  icon appears corresponding to the <b>Characteristic Value</b> field. On clicking the <b>Search</b> icon, the <b>Predefined Characteristic Search</b> window appears.  On specifying the value for a predefined characteristic type, the description of the characteristic value appears corresponding to the <b>Characteristic Value</b> field.	Yes (Conditional)  <b>Note:</b> This field is required when you are defining a characteristic for the bill period based recurring flat fee pricing rule.

2. Enter the required details in the **Characteristics** section.
3. If you want to define more than one characteristic for the bill period based recurring flat fee pricing rule, click the **Add**  icon and then repeat step 2.

**Note:** However, if you want to remove a characteristic from the bill period based recurring flat fee pricing rule, click the **Delete**  icon corresponding to the characteristic.

4. Click **Save**.

The characteristics are defined for the bill period based recurring flat fee pricing rule.

**Related Topics**

For more information on...	See...
How to define a bill period based recurring flat fee pricing rule for a bill group	<a href="#">Defining a Bill Period Based Recurring Flat Fee Pricing Rule for a Bill Group</a> on page 2537
How to edit the bill period based recurring flat fee pricing rule for a bill group	<a href="#">Editing a Bill Period Based Recurring Flat Fee Pricing Rule of a Bill Group</a> on page 2541

**Editing a Bill Period Based Recurring Flat Fee Pricing Rule of a Bill Group****Prerequisites**

To edit a bill period based recurring flat fee pricing rule of a bill group, you should have:

- Business Object **C1-PricingRuleFlatFees** defined for bill period based recurring flat fee pricing rule.

**Procedure**

To edit a bill period based recurring flat fee pricing rule of a bill group:

1. Search for the account, person, or policy whose pricing details you want to view in the **Customer 360° View** screen.
2. In the **Search Results** section, click the **View** () icon corresponding to the account, person, or policy whose pricing details you want to view.

The **Account**, **Person**, or **Policy** tab in the **Customer 360° Information** screen appears.

3. Click the **Pricing** tab, in the **Bill Group ASO Policy Pricing Rules** zone click the **Edit** () icon in the **Edit** column corresponding to the pricing rule type for bill period based recurring flat fee whose bill period based recurring flat fee pricing rule details you want to edit.

The **Flat Fee Pricing Rule** screen appears. It contains the following sections:

- **Customer Information** – Displays the customer information for bill group.
- **Main** – Displays the basic details about the bill period based recurring flat fee pricing rule.
- **Characteristics** – Used to define the characteristics for the bill period based recurring flat fee pricing rule.

The **Customer Information** section contains the following fields:

Field Name	Field Description	Mandatory (Yes or No)
Bill Group Information	Displays the bill group information.	Not applicable
Policy Start Date	Displays the policy start date.	Not applicable
Policy End Date	Displays the policy end date.	Not applicable
Policy Status	Indicates the policy status for pricing rule. The valid values are: <ul style="list-style-type: none"> <li>• In Force/Active</li> <li>• Runout</li> </ul>	Not applicable
Pricing Rule Type	Indicates the pricing rule type.	Not applicable

The **Main** section contains the following fields:

Field Name	Field Description	Mandatory (Yes or No)
Price Item	Indicates the price item.	Not applicable
Charge Start Date	Used to specify the flat fee charge start date.	Yes
Charge End Date	Used to specify the flat fee charge end date.	Yes
Billable Charge Line Type	Displays the billable charge line type.	Not applicable
Bill Period	Indicates the bill period for flat fee.	Not applicable
Fee	Used to specify the amount of flat fee. <b>Note:</b> This field appears only when you have added the billable charge line type in the <b>Billable Charge Line Type</b> field.	Yes
Bill To Account Override	Displays the account to which the bill is override.	Not applicable
Billable Charge Information	Displays the billable charge information.	Not applicable

4. Modify the basic details about the bill period based recurring flat fee pricing rule, if required.
5. Add, edit, or remove characteristics for a bill period based recurring flat fee pricing rule, if required.
6. Click **Save**.

<p><b>Note:</b></p> <p>If <b>Fee</b> is modified then,</p> <ul style="list-style-type: none"> <li>• The bill period based recurring flat fee is saved as a one time charge process.</li> </ul> <p>If <b>Charge Start Date</b> is modified then it checks whether bill segment is already created for a period which is not available for the updated duration then,</p> <ul style="list-style-type: none"> <li>• Bill segment is deleted and existing billable charge is updated.</li> <li>• For recurring flat fee bill segments are not created or is in cancelled status.</li> </ul> <p><b>Note:</b> The modified charge start date should be a future date and not past date.</p>
---

The changes made to a bill period based recurring flat fee pricing rule for a bill group are saved.



#### Related Topics

For more information on...	See...
Customer 360° Information – Pricing tab	<a href="#">Customer 360° Information - Pricing</a> on page 229
Bill Group ASO Policy Pricing Rules zone	<a href="#">Bill Group ASO Policy Pricing Rules</a> on page 237
How to define characteristics for a bill period based recurring flat fee pricing rule	<a href="#">Defining Characteristics for a Bill Period Based Recurring Flat Fee Pricing Rule</a> on page 2540

## Viewing a Bill Period Based Recurring Flat Fee Pricing Rule of a Bill Group

### Procedure

To view a bill period based recurring flat fee pricing rule of a bill group:

1. Search for the account, person, or policy whose pricing details you want to view in the **Customer 360° View** screen.
2. In the **Search Results** section, click the **View** () icon corresponding to the account, person, or policy whose pricing details you want to view.  
The **Account, Person, or Policy** tab in the **Customer 360° Information** screen appears.
3. Click the **Pricing** tab.
4. In the **Bill Group ASO Policy Information** zone, click the **Broadcast** () icon corresponding to the bill group whose bill period based recurring flat fee pricing rule bill group details you want to view.
5. In the **Bill Group ASO Policy Pricing Rules** zone, click the link in the **Pricing Rule Information** column corresponding to the bill period based recurring flat fee pricing rule type whose bill period  
The **Pricing Rule** screen appears. It contains the following zone:
  - **Flat Fee** – Displays the pricing rule bill period based recurring flat fee details for a bill group. It contains the following sections:
    - **Main** – Displays the basic details about the bill period based recurring flat fee pricing rule.
    - **Characteristics** – Displays the characteristics defined for the bill period based recurring flat fee pricing rule.
6. View the basic details of bill period based recurring flat fee pricing rule in the **Main** section.
7. View the characteristics defined for the bill period based recurring flat fee pricing rule in the **Characteristics** section.



#### Related Topics

For more information on...	See...
<b>Customer 360° Information – Pricing</b> tab	<a href="#">Customer 360° Information - Pricing</a> on page 229
<b>Bill Group ASO Policy Pricing Rules</b> zone	<a href="#">Bill Group ASO Policy Pricing Rules</a> on page 237
<b>Pricing Rule</b> screen	<a href="#">Pricing Rule (Used for Viewing)</a> on page 2688
<b>Flat Fee</b> zone	<a href="#">Flat Fee</a> on page 2705

## Deleting a Bill Period Based Recurring Flat Fee Pricing Rule of a Bill Group

### Procedure

To delete a bill period based recurring flat fee pricing rule of a bill group:

1. Search for the account, person, or policy whose pricing details you want to view in the **Customer 360° View** screen.
2. In the **Search Results** section, click the **View** () icon corresponding to the account, person, or policy whose pricing details you want to view.  
The **Account, Person, or Policy** tab in the **Customer 360° Information** screen appears.
3. Click the **Pricing** tab, in the **Bill Group ASO Policy Pricing Rules** zone, click the **Delete** () icon in the **Delete** column corresponding to the bill period based recurring flat fee pricing rule type whose bill period based recurring flat  
A message appears confirming whether you want to delete the bill period based recurring flat fee pricing rule.
4. Click **OK**.  
The bill period based recurring flat fee pricing rule is deleted.

**Related Topics**

For more information on...	See...
Customer 360° Information – Pricing tab	<a href="#">Customer 360° Information - Pricing</a> on page 229
Bill Group ASO Policy Pricing Rules zone	<a href="#">Bill Group ASO Policy Pricing Rules</a> on page 237

**Defining a Frequency Based Recurring Flat Fee Pricing Rule Type****Prerequisites**

To define a frequency based recurring flat fee pricing rule type, you should have:

- Business Object **C1-PricingRuleTypeFlatFees** defined for pricing rule type.
- Business Object **C1-PricingRuleFlatFees** defined for pricing rule.
- Pricing rule type category for flat fees defined in the application.

**Procedure**

To define a frequency based recurring flat fee pricing rule type:

1. Click the **Admin** link in the **Application** toolbar.  
A list appears.
2. From the **Admin** menu, select **P** and then click **Pricing Rule Type**.  
A sub-menu appears.
3. Click the **Add** option from the **Pricing Rule Type** sub-menu.

The **Select Business Object** screen appears. It contains the following field:

Field Name	Field Description	Mandatory (Yes or No)
Pricing Rule Type Business Object	Used to indicate the business object using which you want to create the pricing rule type.  <b>Note:</b> You can create a frequency based recurring flat fee pricing rule type using the <b>Flat Fee Pricing Rule Type</b> business object.	Yes

**Tip:** Alternatively, you can access this screen by clicking the **Add** button in the **Page Title** area of the **Pricing Rule Type** screen.

4. Select the **Flat Fee Pricing Rule Type** business object.
5. Click **OK**.

The **Flat Fee Pricing Rule Type** screen appears. It contains the following sections:

- **Main** – Used to specify basic details about the flat fee pricing rule type.
- **Related Pricing Rule Types** – Used to define the pricing rule types which are related to the parent pricing rule type.
- **Transaction Field Mapping** – Used to specify the transaction related data mapped to the pricing rule type
- **Algorithms** – Used to define the algorithms used for the pricing rule type.
- **Additional Data** – Used to specify the additional information about the pricing rule type.
- **Price Items** – Used to define the price items assigned to the pricing rule type.



- **Price Item Parameters** – Used to define the price item parameters in the pricing rule type.
- **Characteristics** – Used to define the characteristics for the pricing rule type.
- **Billable Charge Line Types** – Used to define the pricing rule type for billable charge line type.
- **Flat Fees - Specific Additional Data** – Used to specify the flat fees specific for additional data.

The **Main** section contains the following fields:

Field Name	Field Description	Mandatory (Yes or No)
Pricing Rule Type	Used to specify the pricing rule type.	Yes
Description	Used to specify the description for the pricing rule type.	Yes
Detailed Description	Used to specify additional information about the pricing rule type.	No
Pricing Rule Business Object	Used to indicate the pricing rule business object. The valid values are: <ul style="list-style-type: none"> <li>• Claim Pricing Rule</li> <li>• Aggregate Stop-Loss (ASL) Pricing Rule</li> <li>• Specific Stop-Loss (SSL) Pricing Rule</li> <li>• Retention Type Claim Based Pricing Rule</li> <li>• Retention Type Enrollment Based Pricing Rule</li> <li>• Flat Fee Pricing Rule</li> </ul>	Yes
Business Object	Indicates the pricing rule type business object for flat fees.	Not applicable
Status	Used to indicate the status of the pricing rule type. The valid values are: <ul style="list-style-type: none"> <li>• Active</li> <li>• Inactive</li> </ul>	Yes
Primary	Used to select the checkbox if the pricing rule type is primary. <div style="border: 1px solid black; padding: 2px; margin-top: 5px;"> <b>Note:</b> This field is not enabled for selection if the <b>Pricing Rule Type Category</b> is <b>Flat Fees</b>. </div>	No
Pricing Rule Type Category	Used to indicate the pricing rule type category for the pricing rule type. The valid values are: <ul style="list-style-type: none"> <li>• Claim</li> <li>• Aggregate Stop-Loss</li> <li>• Specific Stop-Loss</li> <li>• Retention Type Claim Based</li> <li>• Retention Type Enrollment Based</li> <li>• Flat Fees</li> </ul>	Yes

6. Enter the required details in the **Main** section.
7. Add the related pricing rule types in the primary pricing rule type, if required.

**Note:**

**Related Pricing Rule Types** section appears only when the pricing rule type is primary.  
This section does not appear when the **Pricing Rule Type Category** is **Flat Fees**.

8. Define the transaction field mapping in the primary pricing rule type, if required.

**Note:**

**Transaction Field Mapping** section appears only when the pricing rule type is primary.  
This section does not appear when the **Pricing Rule Type Category** is **Flat Fees**.

9. Associate algorithms with the pricing rule type, if required.
10. Define additional data for the pricing rule type, if required.

**Note:** This section does not appear when the **Pricing Rule Type Category** is **Flat Fees**.

11. Add pricing items in the pricing rule type, if required.
12. Add price item parameters in the pricing rule type, if required.
13. Define characteristics for the pricing rule type, if required.
14. Define billable charge line types in the flat fees pricing rule type, if required.
15. Add the flat fees - specific additional data in the pricing rule type, if required.

**Note:**

This section appears only when the **Business Object** is **Flat Fees Pricing Rule Type**.

16. Click **Save**.

The frequency based recurring flat fee pricing rule type is defined.

**Related Topics**

<b>For more information on...</b>	<b>See...</b>
<b>Pricing Rule Type</b> screen	<a href="#">Pricing Rule Type</a> on page 2343
How to add the related pricing rule types in the primary pricing rule type	<a href="#">Adding Related Pricing Rule Types in a Primary Pricing Rule Type</a>
How to define the transaction field mapping in the primary pricing rule type	<a href="#">Defining Transaction Field Mapping in a Primary Pricing Rule Type</a>
How to associate algorithms with the pricing rule type	<a href="#">Associating Algorithms with a Pricing Rule Type</a>
How to define additional data for the pricing rule type	<a href="#">Defining Additional Data for a Pricing Rule Type</a>
How to add pricing items in the pricing rule type	<a href="#">Adding Price Items in a Pricing Rule Type</a>
How to add price item parameters in the pricing rule type	<a href="#">Adding a Price Item Parameter in a Pricing Rule Type</a>
How to define characteristics for the pricing rule type	<a href="#">Defining Characteristics for a Pricing Rule Type</a>

For more information on...	See...
How to add the recurring flat fee specific data in the pricing rule type	<a href="#">Adding the Recurring Flat Fee Specific Data in a Pricing Rule Type</a> on page 2532

## Adding the Recurring Flat Fee Specific Data in a Pricing Rule Type

### Procedure

To add the recurring flat fee specific data in a pricing rule type:

1. Ensure that the **Flat Fees - Specific Additional Data** section is expanded when you are defining or editing a pricing rule type.

The **Flat Fees - Specific Additional Data** section contains the following fields:

Field Name	Field Description	Mandatory (Yes or No)
Bill Segment Cancel Reason	Used to indicate the bill segment cancel reason.	No
Recurring Fee	Used to specify whether the recurring flat fee or one-time flat fee is required.  <b>Note:</b> This field cannot be edited.	No
Recurring Method	Used to indicate whether recurring bill segments must be created at the intervals defined in the bill period or at the invoice frequency. The valid values are: <ul style="list-style-type: none"> <li>• Bill Period</li> <li>• Frequency</li> </ul> <b>Note:</b> This field appears only when you select the checkbox for <b>Recurring Fee</b> field. This field cannot be edited.	Yes (Conditional)  <b>Note:</b> This field is required when you are specifying whether the recurring flat fee is based on bill period or frequency.

The **Flat Fees - Specific Additional Data** section contains the following sub-section:

The **Bill Periods** sub-section contains the following column in a grid:

Column Name	Column Description	Mandatory (Yes or No)
Bill Period	Used to indicate the bill period that you want to use for specifying the intervals at which the recurring bill segments must be created.	Yes

2. Enter the required details in the **Flat Fees - Specific Additional Data** section.
3. Enter the details in the **Bill Periods** sub-section, if required.

**Note:** This sub-section appears only when you have selected **Bill Period** as **Recurring Method**.

4. Click **Save**.

The Flat Fees - Specific Additional data is added in the pricing rule type.

**Related Topics**

For more information on...	See...
How to define a bill period based recurring flat fee pricing rule type	<a href="#">Defining a Bill Period Based Recurring Flat Fee Pricing Rule Type</a> on page 2529
How to define a frequency based recurring flat fee pricing rule type	<a href="#">Defining a Frequency Based Recurring Flat Fee Pricing Rule Type</a> on page 2544
How to edit a bill period based recurring flat fee pricing rule type	<a href="#">Editing a Bill Period Based Recurring Flat Fee Pricing Rule Type</a> on page 2533
How to edit a frequency based recurring flat fee pricing rule type	<a href="#">Editing a Frequency Based Recurring Flat Fee Pricing Rule Type</a> on page 2548

**Editing a Frequency Based Recurring Flat Fee Pricing Rule Type****Prerequisites**

To edit a frequency based recurring flat fee pricing rule type, you should have:

- Business Object **C1-PricingRuleFlatFees** defined for pricing rule.
- Pricing rule type category for flat fees defined in the application.

**Procedure**

To edit a frequency based recurring flat fee pricing rule type:

1. Click the **Admin** link in the **Application** toolbar.  
A list appears.
2. From the **Admin** menu, select **P** and then click **Pricing Rule Type**.  
A sub-menu appears.
3. Click the **Search** option from the **Pricing Rule Type** sub-menu.  
The **Pricing Rule Type** screen appears.
4. In the **Pricing Rule Type List** zone, click the **Edit** (✎) icon in the **Edit** column corresponding to the Pricing rule type whose details you want to edit.

The **Pricing Rule Type** screen appears. It contains the following sections:

- **Main** – Used to specify basic details about the flat fee pricing rule type.
- **Related Pricing Rule Types** – Used to define the pricing rule types which are related to the parent pricing rule type.
- **Transaction Field Mapping** – Used to specify the transaction related data mapped to the pricing rule type
- **Algorithms** – Used to define the algorithms used for the pricing rule type.
- **Additional Data** – Used to specify the additional information about the pricing rule type.
- **Price Items** – Used to define the price items assigned to the pricing rule type.
- **Price Item Parameters** – Used to define the price item parameters in the pricing rule type.
- **Characteristics** – Used to define the characteristics for the pricing rule type.
- **Billable Charge Line Types** – Used to define the pricing rule type for billable charge line type.
- **Flat Fees - Specific Additional Data** – Used to specify the flat fees specific for additional data.

The **Main** section contains the following fields:

Field Name	Field Description	Mandatory (Yes or No)
Pricing Rule Type	Displays the pricing rule type.	Not applicable
Description	Used to specify the description for the pricing rule type.	Yes
Detailed Description	Used to specify additional information about the pricing rule type.	No
Pricing Rule Business Object	Used to indicate the pricing rule business object. The valid values are: <ul style="list-style-type: none"> <li>• Claim Pricing Rule</li> <li>• Aggregate Stop-Loss (ASL) Pricing Rule</li> <li>• Specific Stop-Loss (SSL) Pricing Rule</li> <li>• Retention Type Claim Based Pricing Rule</li> <li>• Retention Type Enrollment Based Pricing Rule</li> <li>• Flat Fee Pricing Rule</li> </ul>	Yes
Business Object	Indicates the pricing rule type business object for flat fees.	Not applicable
Status	Used to indicate the status of the pricing rule type. The valid values are: <ul style="list-style-type: none"> <li>• Active</li> <li>• Inactive</li> </ul>	Yes
Primary	Used to select the checkbox if the pricing rule type is primary.  <div style="border: 1px solid black; padding: 2px;"> <b>Note:</b> This field is not enabled for selection if the <b>Pricing Rule Type Category</b> is <b>Flat Fees</b>. </div>	No
Pricing Rule Type Category	Used to indicate the pricing rule type category for the pricing rule type. The valid values are: <ul style="list-style-type: none"> <li>• Claim</li> <li>• Aggregate Stop-Loss</li> <li>• Specific Stop-Loss</li> <li>• Retention Type Claim Based</li> <li>• Retention Type Enrollment Based</li> <li>• Flat Fees</li> </ul>	Yes

**Tip:** Alternatively, you can edit the details of a frequency based recurring flat fees pricing rule type by clicking the **Edit** button in the **Pricing Rule Type** zone.

5. Modify the required details in the **Main** section.
6. Define, edit or remove related pricing rule types from the primary pricing rule type, if required.

**Note:**

**Related Pricing Rule Types** section appears only when the pricing rule type is primary.

This section does not appear when the **Pricing Rule Type Category** is **Flat Fees**.

7. Modify the details of transaction field mapping, if required.

**Note:**

**Transaction Field Mapping** section appears only when the pricing rule type is primary.

This section does not appear when the **Pricing Rule Type Category** is **Flat Fees**.

8. Define, edit or remove algorithms from the pricing rule type, if required.
9. Modify additional data for the pricing rule type, if required.

**Note:** This section does not appear when the **Pricing Rule Type Category** is **Flat Fees**.

10. Define, edit or remove price items from the pricing rule type, if required.
11. Define, edit or remove price items from the pricing rule type, if required.
12. Define, edit, or remove characteristics from the pricing rule type, if required.
13. Define, edit or remove billable charge line types for the flat fees pricing rule type, if required.
14. Modify flat fees - specific additional data in the pricing rule type, if required.

**Note:** This section appears only when the **Business Object** is **Flat Fees Pricing Rule Type**.

15. Click **Save**.

The changes made to the frequency based recurring flat fee pricing rule type are saved.

**Related Topics**

<b>For more information on...</b>	<b>See...</b>
<b>Pricing Rule Type</b> screen	<a href="#">Pricing Rule Type</a> on page 2343
<b>Pricing Rule Type List</b> zone	<a href="#">Pricing Rule Type List</a> on page 2344
<b>Pricing Rule Type</b> zone	<a href="#">Pricing Rule Type</a> on page 2347
How to add the related pricing rule types in the primary pricing rule type	<a href="#">Adding Related Pricing Rule Types in a Primary Pricing Rule Type</a>
How to define the transaction field mapping in the primary pricing rule type	<a href="#">Defining Transaction Field Mapping in a Primary Pricing Rule Type</a>
How to associate algorithms with the pricing rule type	<a href="#">Associating Algorithms with a Pricing Rule Type</a>
How to define additional data for the pricing rule type	<a href="#">Defining Additional Data for a Pricing Rule Type</a>
How to add pricing items in the pricing rule type	<a href="#">Adding Price Items in a Pricing Rule Type</a>
How to add price item parameters in the pricing rule type	<a href="#">Adding a Price Item Parameter in a Pricing Rule Type</a>
How to define characteristics for the pricing rule type	<a href="#">Defining Characteristics for a Pricing Rule Type</a>

For more information on...	See...
How to add the recurring flat fee specific data in the pricing rule type	<a href="#">Adding the Recurring Flat Fee Specific Data in a Pricing Rule Type</a> on page 2532

## Deleting a Frequency Based Recurring Flat Fee Pricing Rule Type

### Procedure

To delete a frequency based recurring flat fee pricing rule type:

1. Click the **Admin** link in the **Application** toolbar.  
A list appears.
2. From the **Admin** menu, select **P** and then click **Pricing Rule Type**.  
A sub-menu appears.
3. Click the **Search** option from the **Pricing Rule Type** sub-menu.  
The **Pricing Rule Type** screen appears.
4. In the **Pricing Rule Type List** zone, click the **Delete** (🗑) icon in the **Delete** column corresponding to the frequency based recurring flat fee pricing rule type that you want to delete.

A message appears confirming whether you want to delete the frequency based recurring flat fee pricing rule type.

**Note:** You can delete a frequency based recurring flat fee pricing rule type only when it is not yet used in the system.

**Tip:** Alternatively, you can delete a frequency based recurring flat fee pricing rule type by clicking the **Delete** button in the **Pricing Rule Type** zone.

5. Click **OK**.  
The frequency based recurring flat fee pricing rule type is deleted.

### Related Topics

For more information on...	See...
<b>Pricing Rule Type</b> screen	<a href="#">Pricing Rule Type</a> on page 2343
<b>Pricing Rule Type List</b> zone	<a href="#">Pricing Rule Type List</a> on page 2344
<b>Pricing Rule Type</b> zone	<a href="#">Pricing Rule Type</a> on page 2347

## Viewing the Frequency Based Recurring Flat Fee Pricing Rule Type Details

### Procedure

To view the details of a frequency based recurring flat fee pricing rule type:

1. Click the **Admin** link in the **Application** toolbar.  
A list appears.
2. From the **Admin** menu, select **P** and then click **Pricing Rule Type**.  
A sub-menu appears.
3. Click the **Search** option from the **Pricing Rule Type** sub-menu.  
The **Pricing Rule Type** screen appears.

4. In the **Pricing Rule Type List** zone, click the **Broadcast**  icon corresponding to the frequency based recurring flat fee pricing rule type whose details you want to view.

The **Pricing Rule Type** zone appears.

5. View the details of the frequency based recurring flat fee pricing rule type in the **Pricing Rule Type** zone.

### Related Topics

For more information on...	See...
<b>Pricing Rule Type</b> screen	<a href="#">Pricing Rule Type</a> on page 2343
<b>Pricing Rule Type List</b> zone	<a href="#">Pricing Rule Type List</a> on page 2344
<b>Pricing Rule Type</b> zone	<a href="#">Pricing Rule Type</a> on page 2347

## Defining a Frequency Based Recurring Flat Fee Pricing Rule for a Bill Group

### Prerequisites

To define a frequency based recurring flat fee pricing rule for a bill group, you should have:

- Business Object **C1-PricingRule** defined for pricing rule.
- Business Object **C1-PricingRuleFlatFees** defined for frequency based recurring flat fee pricing rule.
- Pricing rule type defined in the application.
- Policy status defined in the application.
- Price item defined in the application.
- Billable Charge Line Type defined in the application.

### Procedure

To define a frequency based recurring flat fee pricing rule for a bill group:

1. Search for the account, person, or policy whose pricing details you want to view in the **Customer 360° View** screen.
2. In the **Search Results** section, click the **View**  icon corresponding to the account, person, or policy whose pricing details you want to view.

The **Account**, **Person**, or **Policy** tab in the **Customer 360° Information** screen appears.

3. Click the **Pricing** tab and then click the **Add** link in the upper right corner of the **Bill Group ASO Policy Pricing Rules** zone.

The **Pricing Rule** screen appears. It contains the following fields:

Field Name	Field Description	Mandatory (Yes or No)
Person Name	Displays the person name.	Not applicable
Person Type	Displays the person type.	Not applicable
Pricing Rule Type	Used to indicate the pricing rule type to create the pricing rule.  <b>Note:</b> You can create a frequency based recurring flat fee pricing rule using the <b>Pricing Rule Type</b> for flat fees.	Yes



Field Name	Field Description	Mandatory (Yes or No)
Policy Status	Used to indicate the policy status for pricing rule. The valid values are: <ul style="list-style-type: none"> <li>In Force/Active</li> <li>Runout</li> </ul>	Yes

4. Click **OK**.

The **Flat Fee Pricing Rule** screen appears. It contains the following sections:

- **Customer Information** – Displays the customer information for bill group.
- **Main** – Used to specify basic details about the frequency based recurring flat fee pricing rule.
- **Characteristics** – Used to define the characteristics for the frequency based recurring flat fee pricing rule.

The **Customer Information** section contains the following fields:

Field Name	Field Description	Mandatory (Yes or No)
Bill Group Information	Displays the bill group information.	Not applicable
Policy Start Date	Displays the policy start date.	Not applicable
Policy End Date	Displays the policy end date.	Not applicable
Policy Status	Indicates the policy status for pricing rule. The valid values are: <ul style="list-style-type: none"> <li>In Force/Active</li> <li>Runout</li> </ul>	Not applicable
Pricing Rule Type	Indicates the pricing rule type.	Not applicable

The **Main** section contains the following fields:

Field Name	Field Description	Mandatory (Yes or No)
Price Item	Used to indicate the price item.	Yes
Charge Start Date	Used to specify the flat fee charge start date.	Yes
Billable Charge Line Type	Used to specify the billable charge line type. <div style="border: 1px solid black; padding: 5px; margin-top: 10px;"> <p><b>Note:</b></p> <p>On clicking the <b>Search</b>  icon, the <b>Billable Charge Line Type Search</b> window appears.</p> <p>On specifying the billable charge line type, the description of the billable charge line type appears corresponding to the <b>Billable Charge Line Type</b> field.</p> </div>	No
Charge End Date	Used to specify the flat fee charge end date.	No
Frequency	Used to indicate the frequency for flat fee.	Yes

Field Name	Field Description	Mandatory (Yes or No)
Fee	Used to specify the amount of flat fee.  <b>Note:</b> This field appears only when you select the billable charge line type in the <b>Billable Charge Line Type</b> field.	Yes
Bill To Account Override	Used to specify the account to which the bill is override.  <b>Note:</b> On clicking the <b>Search</b> (🔍) icon, the <b>Account Search</b> window appears. On specifying the account, the description of the account appears corresponding to the <b>Bill To Account Override</b> field.	Yes

5. Enter the required details in the **Main** section.
6. Define characteristics for a frequency based recurring flat fee pricing rule, if required.
7. Click **Save**.

The frequency based recurring flat fee pricing rule for a bill group is defined.

**Note:** A billable charge is created and assigned to the frequency based recurring flat fee pricing rule.

#### **Related Topics**

For more information on...	See...
<b>Customer 360° Information – Pricing</b> tab	<a href="#">Customer 360° Information - Pricing</a> on page 229
<b>Bill Group ASO Policy Pricing Rules</b> zone	<a href="#">Bill Group ASO Policy Pricing Rules</a> on page 237
How to define characteristics for a frequency based recurring flat fee pricing rule	<a href="#">Defining Characteristics for a Frequency Based Recurring Flat Fee Pricing Rule</a> on page 2554

## **Defining Characteristics for a Frequency Based Recurring Flat Fee Pricing Rule**

### **Prerequisites**

To define characteristics for a frequency based recurring flat fee pricing rule, you should have:

- Characteristic types defined in the application (where the characteristic entity is set to **Pricing Rule**)

### **Procedure**

To define characteristics for a frequency based recurring flat fee pricing rule:

1. Ensure that the **Characteristics** section is expanded when you are defining or editing a pricing rule.

The **Characteristics** section contains the following columns in a grid:

Column Name	Column Description	Mandatory (Yes or No)
Effective Date	Used to specify the date from when the characteristic is effective for the frequency based recurring flat fee pricing rule.	Yes (Conditional)  <b>Note:</b> This field is required when you are defining a characteristic for the frequency based recurring flat fee pricing rule.
Characteristic Type	Used to indicate the characteristic type.  <b>Note:</b> The list includes only those characteristic types where the characteristic entity is set to <b>Pricing Rule</b> .	Yes (Conditional)  <b>Note:</b> This field is required when you are defining a characteristic for the frequency based recurring flat fee pricing rule.
Characteristic Value	Used to specify the value for the characteristic type.  <b>Note:</b> If you select a predefined characteristic type, the <b>Search</b>  icon appears corresponding to the <b>Characteristic Value</b> field. On clicking the <b>Search</b> icon, the <b>Predefined Characteristic Search</b> window appears.  On specifying the value for a predefined characteristic type, the description of the characteristic value appears corresponding to the <b>Characteristic Value</b> field.	Yes (Conditional)  <b>Note:</b> This field is required when you are defining a characteristic for the frequency based recurring flat fee pricing rule.

- Enter the required details in the **Characteristics** section.
- If you want to define more than one characteristic for the frequency based recurring flat fee pricing rule, click the **Add**  icon and then repeat step 2.

**Note:** However, if you want to remove a characteristic from the frequency based recurring flat fee pricing rule, click the **Delete**  icon corresponding to the characteristic.

- Click **Save**.

The characteristics are defined for the frequency based recurring flat fee pricing rule.

### **Related Topics**

For more information on...	See...
How to define a frequency based recurring flat fee pricing rule for a bill group	<a href="#">Defining a Frequency Based Recurring Flat Fee Pricing Rule for a Bill Group</a> on page 2552
How to edit the frequency based recurring flat fee pricing rule for a bill group	<a href="#">Editing a Frequency Based Recurring Flat Fee Pricing Rule of a Bill Group</a> on page 2555

## **Editing a Frequency Based Recurring Flat Fee Pricing Rule of a Bill Group**

### **Prerequisites**

To edit a frequency based recurring flat fee pricing rule of a bill group, you should have:

- Business Object **C1-PricingRuleFlatFees** defined for frequency based recurring flat fee pricing rule.

### **Procedure**

To edit a frequency based recurring flat fee pricing rule of a bill group:

1. Search for the account, person, or policy whose pricing details you want to view in the **Customer 360° View** screen.
2. In the **Search Results** section, click the **View** () icon corresponding to the account, person, or policy whose pricing details you want to view.

The **Account, Person, or Policy** tab in the **Customer 360° Information** screen appears.

3. Click the **Pricing** tab, in the **Bill Group ASO Policy Pricing Rules** zone click the **Edit** () icon in the **Edit** column corresponding to the pricing rule type for frequency based recurring flat fee whose frequency based recurring flat

The **Flat Fee Pricing Rule** screen appears. It contains the following sections:

- **Customer Information** – Displays the customer information for bill group.
- **Main** – Displays the basic details about the frequency based recurring flat fee pricing rule.
- **Characteristics** – Used to define the characteristics for the frequency based recurring flat fee pricing rule.

The **Customer Information** section contains the following fields:

Field Name	Field Description	Mandatory (Yes or No)
Bill Group Information	Displays the bill group information.	Not applicable
Policy Start Date	Displays the policy start date.	Not applicable
Policy End Date	Displays the policy end date.	Not applicable
Policy Status	Indicates the policy status for pricing rule. The valid values are: <ul style="list-style-type: none"> <li>• In Force/Active</li> <li>• Runout</li> </ul>	Not applicable
Pricing Rule Type	Indicates the pricing rule type.	Not applicable

The **Main** section contains the following fields:

Field Name	Field Description	Mandatory (Yes or No)
Price Item	Indicates the price item.	Not applicable
Charge Start Date	Used to specify the flat fee charge start date.	Yes
Charge End Date	Used to specify the flat fee charge end date.	Yes
Billable Charge Line Type	Displays the billable charge line type.	Not applicable
Frequency	Indicates the frequency for flat fee.	Not applicable
Fee	Used to specify the amount of flat fee.  <div style="border: 1px solid black; padding: 5px; margin-top: 10px;"> <b>Note:</b> This field appears only when you have added the billable charge line type in the <b>Billable Charge Line Type</b> field. </div>	Yes

Field Name	Field Description	Mandatory (Yes or No)
Bill To Account Override	Displays the account to which the bill is override.	Not applicable
Billable Charge Information	Displays the billable charge information.	Not applicable

4. Modify the basic details about the frequency based recurring flat fee pricing rule, if required.
5. Add, edit, or remove characteristics for a frequency based recurring flat fee pricing rule, if required.
6. Click **Save**.

<p><b>Note:</b></p> <p>If <b>Fee</b> is modified then,</p> <ul style="list-style-type: none"> <li>• The frequency based recurring flat fee is saved as a one time charge process.</li> </ul> <p>If <b>Charge Start Date</b> is modified then it checks whether bill segment is already created for a period which is not available for the updated duration then,</p> <ul style="list-style-type: none"> <li>• Bill segment is deleted and existing billable charge is updated.</li> <li>• For recurring flat fee bill segments are not created or is in cancelled status.</li> </ul> <p><b>Note:</b> The modified charge start date should be a future date and not past date.</p>
---

The changes made to a frequency based recurring flat fee pricing rule for a bill group are saved.



#### Related Topics

For more information on...	See...
<b>Customer 360° Information – Pricing</b> tab	<a href="#">Customer 360° Information - Pricing</a> on page 229
<b>Bill Group ASO Policy Pricing Rules</b> zone	<a href="#">Bill Group ASO Policy Pricing Rules</a> on page 237
How to define characteristics for a frequency based recurring flat fee pricing rule	<a href="#">Defining Characteristics for a Frequency Based Recurring Flat Fee Pricing Rule</a> on page 2554

## Viewing a Frequency Based Recurring Flat Fee Pricing Rule of a Bill Group

### Procedure

To view a frequency based recurring flat fee pricing rule of a bill group:

1. Search for the account, person, or policy whose pricing details you want to view in the **Customer 360° View** screen.
2. In the **Search Results** section, click the **View** () icon corresponding to the account, person, or policy whose pricing details you want to view.  
The **Account, Person, or Policy** tab in the **Customer 360° Information** screen appears.
3. Click the **Pricing** tab.
4. In the **Bill Group ASO Policy Information** zone, click the **Broadcast** () icon corresponding to the bill group whose frequency based recurring flat fee pricing rule bill group details you want to view.
5. In the **Bill Group ASO Policy Pricing Rules** zone, click the link in the **Pricing Rule Information** column corresponding to the frequency based recurring flat fee pricing rule type whose frequency based flat fee pricing rule bill group

The **Pricing Rule** screen appears. It contains the following zone:

- **Flat Fee** – Displays the pricing rule frequency based recurring flat fee details for a bill group. It contains the following sections:
    - **Main** – Displays the basic details about the frequency based recurring flat fee pricing rule.
    - **Characteristics** – Displays the characteristics defined for the frequency based recurring flat fee pricing rule.
6. View the basic details of frequency based recurring flat fee pricing rule in the **Main** section.
  7. View the characteristics defined for the frequency based recurring flat fee pricing rule in the **Characteristics** section.



#### Related Topics

For more information on...	See...
<b>Customer 360° Information – Pricing</b> tab	<a href="#">Customer 360° Information - Pricing</a> on page 229
<b>Bill Group ASO Policy Pricing Rules</b> zone	<a href="#">Bill Group ASO Policy Pricing Rules</a> on page 237
<b>Pricing Rule</b> screen	<a href="#">Pricing Rule (Used for Viewing)</a> on page 2688
<b>Flat Fee</b> zone	<a href="#">Flat Fee</a> on page 2705

## Deleting a Frequency Based Recurring Flat Fee Pricing Rule of a Bill Group

### Procedure

To delete a frequency based recurring flat fee pricing rule of a bill group:

1. Search for the account, person, or policy whose pricing details you want to view in the **Customer 360° View** screen.
2. In the **Search Results** section, click the **View** () icon corresponding to the account, person, or policy whose pricing details you want to view.  
The **Account, Person, or Policy** tab in the **Customer 360° Information** screen appears.
3. Click the **Pricing** tab, in the **Bill Group ASO Policy Pricing Rules** zone, click the **Delete** () icon in the **Delete** column corresponding to the frequency based recurring flat fee pricing rule type whose frequency based recurring flat fee pricing rule you want to delete.  
A message appears confirming whether you want to delete the frequency based recurring flat fee pricing rule.
4. Click **OK**.  
The frequency based recurring flat fee pricing rule is deleted.

### Related Topics

For more information on...	See...
<b>Customer 360° Information – Pricing</b> tab	<a href="#">Customer 360° Information - Pricing</a> on page 229
<b>Bill Group ASO Policy Pricing Rules</b> zone	<a href="#">Bill Group ASO Policy Pricing Rules</a> on page 237

## Ancillary Pricing

The Administrative Services Only (ASO) provider may process some adhoc charges with respect to preventive care, vaccination, diagnostic, and so on. These adhoc charges may also occur due to some corrections in the claim transactions

which are already billed to the customer. Oracle Revenue Management and Billing enables you to process and bill these ancillary transactions to the self-funded employer.

The system enables you to create an ancillary charge in either of the following ways:

- Create a pass through charge without markup or markdown (i.e. flat charge).
- Create a pass through charge with a flat or percentage based markup or markdown.
- Create a rate based charge using the rate defined in the ancillary pricing and the service quantity specified in the ancillary transaction. You can also apply markup or markdown to a rate based charge.

You can use any custom mechanism or the file upload utility in ORMB to upload the ancillary transactions. The pricing for the ancillary transactions can be defined using the ancillary pricing rules. You can define an ancillary pricing rule at the parent customer and bill group levels. The ancillary pricing rule at the bill group level takes precedence over the ancillary pricing rule at the parent customer level. You can define the ancillary pricing rules for parent customers and bill groups from the **Customer 360° Information** screen. You can define an ancillary pricing rule using an ancillary pricing rule type. It is the ancillary pricing rule type which helps the system to determine:

- Business object using which the ancillary pricing rule should be created in the system.
- Whether it is the primary pricing rule type from where the related pricing rule types will inherit the transaction field mapping details.

**Note:** You must select the **Primary** option while defining an ancillary pricing rule type. On selecting the **Primary** option, the **Related Pricing Rule Types** and **Transaction Field Mapping** sections appear in the **Ancillary Pricing Rule Type** screen.

- Rule type which indicates the rules that should be executed to determine whether the related pricing rule type is eligible for deriving the transaction legs.
- Transaction fields from where the data from the ancillary transaction should be stored in the respective fields (for example, the data from the **UDF\_CHAR\_1** transaction field must be stored in the **Parameter 1** field which will be used for deriving the bill group and pricing).
- Algorithm which should be triggered for validating an ancillary transaction.

**Note:** An algorithm type for validating an ancillary transaction is not shipped with the product. You can create a custom algorithm type, if required.

- Algorithm which should be triggered for deriving the bill group, parent customer, and policy for an ancillary transaction.

**Note:** You must create an algorithm using the **C1\_TXNBGDRV** algorithm type and attach it to the **Bill Group Derivation** system event.

- Algorithm which should be triggered for deriving the account and price item for an ancillary transaction.

**Note:** You must create an algorithm using the **C1\_ACCPRIDRV** algorithm type and attach it to the **Account and Price Item Derivation** system event.

- Algorithm which should be triggered for determining the bill after date.

**Note:** You must create an algorithm using the **C1\_BAFTDRV** algorithm type and attach it to the **Bill After Date Determination** system event.

- Pricing rule post-processing algorithm which should be triggered once the effective ancillary pricing rule is derived.

**Note:** A pricing rule post-processing algorithm type is not shipped with the product. You can create a custom algorithm type, if required.

- Additional generic information, such as:

- Whether the price items included in the ancillary pricing rule type are eligible for specific stop-loss and aggregate stop-loss.
- Whether the price items included in the ancillary pricing rule type are eligible for level funding.
- Whether the ancillary charges should be written off when the bill is generated in the post runout period of the policy. In this case, a write-off adjustment is created against the respective bill segment during the post bill completion. The write-off adjustment is created using the post runout write-off adjustment type which is specified in the ancillary pricing rule type.
- Transaction field which you want to use in the rules as the output parameter to determine whether the price item should be considered for billing.
- Transaction field which you want to use in the rules as the output parameter to determine whether the related pricing rule type should be considered for deriving the transaction legs.
- Value which the output parameter in the rule should return when the price item and related pricing rule type in the ancillary pricing rule type should be considered for processing.
- Price items for which you can define ancillary pricing rules using the ancillary pricing rule type.
- Rate options that you can use while defining the pricing for the ancillary price items.
- Different type of account to which a price item should be billed based on the specified priority.
- Rule type which indicates the rules that should be executed to determine whether the price item is eligible for billing.
- Price item parameters based on which you want to define the price item pricing. Two price item parameters are mandatory in the ancillary pricing rule type – one which stores the billable charge line type from the ancillary transaction and another which stores the pricing arrangement from the ancillary transaction. The following pricing arrangements are supported in the ancillary pricing rule:
  - Pass Through Charge Without Markup and Markdown
  - Pass Through Charge With Markup and Markdown
  - Rate Based Charge Without Markup and Markdown
  - Rate Based Charge With Markup and Markdown

**Note:** The price item parameters (for example, BCHGLINETYPE and PRICINGARRANGEMENT) which you include in the ancillary pricing rule type must be defined in the **Billable Charge Line Type Parameter** and **Pricing Arrangement Parameter** option types of the **C1-ASOBLNG** feature configuration, respectively.

- Additional ancillary-specific information, such as:
  - Identifiers which help to determine whether the ancillary transaction is eligible for billing for not.
  - Transaction field which you want to use in the rules as the output parameter to determine whether the markup or markdown calculation line is eligible for billing.
  - Billable charge line type using which you want to create billable charges for markup and markdown.
  - Rule type which indicates the rules which should be executed to determine whether the markup or markdown calculation line is eligible for billing.
  - How the system should interpret the value stored in the pricing arrangement price item parameter (i.e. whether the value means the ancillary charge should be a pass through charge without markup or markdown, pass through charge with markup or markdown, or rate based charge with or without markup or markdown). Accordingly, the system will search for the pricing in the effective ancillary pricing rule where:
    - Billable charge line type matches the one specified in the ancillary transaction
    - Line defined for the billable charge line type has the pricing arrangement as mentioned in the ancillary transaction



- Line item which indicates the SQI using which the ancillary charge should be created. You need to specify the line item for each pricing arrangement which is defined in the ancillary pricing rule type.

Once an ancillary pricing rule type is defined, you can create ancillary pricing rules using the ancillary pricing rule type. While defining an ancillary pricing rule for a parent customer and bill group, you need to specify the following:

- Price item for which you want to define the pricing.
- Pricing date range during which the pricing is effective.
- Rate option which you want to use while defining the ancillary pricing.
- Whether you want to define the pricing for a pass through charge without markup or markdown. If you select the **Pass Through without Markup or Markdown** option, you cannot define the pricing for a pass through charge with markup or markdown and the pricing for rate based charge with or without markup or markdown in the ancillary pricing rule. However, if the **Pass Through without Markup or Markdown** option is not selected, you can define pricing for different billable charge line types which can be with markup or markdown or which can be rate based with or without markup or markdown. In addition, if the **Pass Through without Markup or Markdown** option is not selected, by default, the system will define the pricing for a pass through charge without markup or markdown. Depending on the billable charge line type and pricing arrangement information in the ancillary transaction, the system will accordingly fetch the appropriate pricing for billing the ancillary charge. For example, if the ancillary transaction contains BCLT1 as the billable charge line type and PASSMK as the pricing arrangement and the effective ancillary pricing rule contains the following pricing:

Ancillary Pricing	Billable Charge Line Type	Pricing Arrangement	Rate	Pricing Strategy	Markup Amount	Markdown Amount
AP1	BCLT0	Pass Through with Markup or Markdown	-	Markup	\$10	-
AP2	BCLT1	Pass Through with Markup or Markdown	-	Markdown	-	\$5
AP3	BCLT2	Rate Based without Markup or Markdown	\$5	-	-	-
AP4	BCLT3	Rate Based with Markup or Markdown	\$5	Markup	\$10	-
AP5	BCLT4	Rate Based with Markup or Markdown	\$5	Markdown	-	\$5
AP6	-	Pass Through without Markup or Markdown	-	-	-	-

In this case, the system will use the AP2 pricing defined in the ancillary pricing rule. The system will markdown the SQI with the specified amount (i.e. \$5).

- Whether the billable charge line type is eligible for billing or not. Accordingly, the system will create billable charge for the ancillary transaction.

In addition, while defining an ancillary pricing rule for a bill group, you need to indicate the policy status for which the ancillary pricing rule is applicable. You can also specify a pricing group while defining an ancillary pricing rule for a bill group. Once an ancillary pricing rule is created, the system creates multiple price assignments in a price list and assigns the price list to the bill group.

## Defining an Ancillary Pricing Rule Type

### Prerequisites

To define an ancillary pricing rule type, you should have:

- Ancillary pricing rule type business object defined in the application.

- Ancillary pricing rule business object defined in the application.

### **Procedure**

To define an ancillary pricing rule type:

1. Click the **Admin** link in the **Application** toolbar.  
A list appears.
2. From the **Admin** menu, select **P** and then click **Pricing Rule Type**.  
A sub-menu appears.
3. Click the **Add** option from the **Pricing Rule Type** sub-menu.

The **Select Business Object** screen appears. It contains the following field:

<b>Field Name</b>	<b>Field Description</b>	<b>Mandatory (Yes or No)</b>
Pricing Rule Type Business Object	<p>Used to indicate the business object using which you want to create an ancillary pricing rule type. The valid values are:</p> <ul style="list-style-type: none"> <li>• Aggregate Stop-Loss (ASL) Pricing Rule Type</li> <li>• Ancillary Pricing Rule Type</li> <li>• Claim Pricing Rule Type</li> <li>• Discount Arrangement Pricing Rule Type</li> <li>• Flat Fee Pricing Rule Type</li> <li>• Level Funded (LF) Pricing Rule Type</li> <li>• Retention Type Claim Based Pricing Rule Type</li> <li>• Retention Type Enrollment Based Pricing Rule Type</li> <li>• Specific Stop-Loss (SSL) Pricing Rule Type</li> </ul> <p><b>Note:</b> You must select the <b>Ancillary Pricing Rule Type</b> option from the <b>Pricing Rule Type Business Object</b> list while defining an ancillary pricing rule type.</p>	Yes

**Tip:** Alternatively, you can access this screen by clicking the **Add** button in the **Page Title** area of the **Pricing Rule Type** screen.

4. Select the **Ancillary Pricing Rule Type** option from the **Pricing Rule Type Business Object** list.
5. Click **OK**.

The **Ancillary Pricing Rule Type** screen appears. It contains the following sections:

- **Main** – Used to specify the basic details about the ancillary pricing rule type.
- **Related Pricing Rule Types** – Used to indicate the non-primary pricing rule types which should inherit the transaction field mapping details from the ancillary pricing rule type. You can add a pricing rule type which belongs to the following category:
  1. Specific Stop Loss
  2. Aggregate Stop Loss
  3. Level Funding

**Note:** You can use any of the above specified pricing rule types as the related pricing rule type in an ancillary pricing rule type.

- **Transaction Field Mapping** – Used to map the transaction fields in a ancillary transaction to the appropriate fields in the ancillary pricing rule type. This helps the system to determine the field where the data from the transaction field must be stored. This data is then used in the system for various reasons, such as for deriving a bill group and pricing, deriving an effective related pricing rule, and so on.

**Note:** The **Billing Eligibility Identifier** field is required when you are defining the **Transaction Field Mapping** for an ancillary pricing rule type.

- **Algorithms** – Used to associate the algorithms with an ancillary pricing rule type.
- **Additional Data** – Used to specify additional information about the ancillary pricing rule type.
- **Price Items** – Used to add the price items for which you can define the ancillary pricing rules using the ancillary pricing rule type.
- **Price Item Parameters** – Used to add the price item parameters based on which you want to define the price item pricing.

**Note:** There are two price item parameters that are mandatory in the ancillary pricing rule type:

- A price item which stores the billable charge line type from the ancillary transaction.
- A price item which stores the pricing arrangement from the ancillary transaction.

- **Characteristics** – Used to define the characteristics for an ancillary pricing rule type.
- **Ancillary-Specific Additional Data** – Used to define the ancillary-specific additional data in an ancillary pricing rule type.

**Note:** Following fields are required when you are defining the **Ancillary-Specific Additional Data** for the ancillary pricing rule type.

- **Billing Eligibility Identifier Value**
- **Billing Non-Eligibility Identifier Value**

- **Pricing Arrangements** – Used to define the following pricing arrangements that are used while defining an ancillary pricing rule type.
  - **Pass Through (Markup or Markdown Optional)**
  - **Pass Through Without Markup or Markdown**
  - **Rate Based (Markup or Markdown Optional)**

The **Main** section contains the following fields:

Field Name	Field Description	Mandatory (Yes or No)
Pricing Rule Type	Used to specify the ancillary pricing rule type.	Yes
Description	Used to specify the description for the ancillary pricing rule type.	Yes
Detailed Description	Used to specify additional information about the ancillary pricing rule type.	No

Field Name	Field Description	Mandatory (Yes or No)
Pricing Rule Business Object	<p>Used to indicate the business object using which you want to create the ancillary pricing rule. The valid values are:</p> <ul style="list-style-type: none"> <li>• Aggregate Stop-Loss (ASL) Pricing Rule</li> <li>• Ancillary Pricing Rule</li> <li>• Claim Pricing Rule</li> <li>• Discount Arrangement Pricing Rule</li> <li>• Flat Fee Pricing Rule</li> <li>• Level Funded (LF) Pricing Rule</li> <li>• Retention Type Claim Based Pricing Rule</li> <li>• Retention Type Enrollment Based Pricing Rule</li> <li>• Specific Stop-Loss (SSL) Pricing Rule</li> </ul> <p><b>Note:</b> You must select the <b>Ancillary Pricing Rule</b> option from the <b>Pricing Rule Business Object</b> list while defining an ancillary pricing rule type.</p>	Yes
Business Object	Indicates the business object using which you are defining the ancillary pricing rule type.	Not applicable
Status	<p>Used to indicate the status of the ancillary pricing rule type. The valid values are:</p> <ul style="list-style-type: none"> <li>• Active</li> <li>• Inactive</li> </ul>	Yes
Primary	Used to indicate whether the ancillary pricing rule type is a primary pricing rule type.	No
Pricing Rule Type Category	<p>Used to indicate the category to which the ancillary pricing rule type belongs. The valid value are:</p> <ul style="list-style-type: none"> <li>• Aggregate Stop-Loss</li> <li>• Ancillary</li> <li>• Claim</li> <li>• Discount Arrangement</li> <li>• Flat Fees</li> <li>• Level Funded</li> <li>• Retention Type Claim Based</li> <li>• Retention Type Enrollment Based</li> <li>• Specific Stop-Loss</li> </ul> <p><b>Note:</b> You must select the <b>Ancillary</b> option from the <b>Pricing Rule Type Category</b> list while defining an ancillary pricing rule type.</p>	Yes

6. Enter the required details in the **Main** section.

7. Select the **Ancillary Pricing Rule** option from the **Pricing Rule Business Object** list.
8. Select the **Primary** option in the **Main** section.

The **Related Pricing Rule Types** and **Transaction Field Mapping** sections appear.

9. Select the **Ancillary** option from the **Pricing Rule Type Category** list.
10. Add the related pricing rule types in the ancillary pricing rule type, if required.
11. Map the transaction fields of an ancillary transaction to the appropriate fields in the ancillary pricing rule type.
12. Associate the following algorithms with the ancillary pricing rule type:

System Event	Algorithm	Algorithm Type	Description
Bill Group Derivation	C1_TXNBGDRV	C1_TXNBGDRV	Derive Bill Group
Account and Price Item Derivation	C1_ACCPRIDRV	C1_ACCPRIDRV	Account and Price Item Derivation
Bill After Date Determination	C1_BAFTDRV	C1_BAFTDRV	Bill After Date Determination

13. Define additional data for an ancillary pricing rule type, if required.
14. Add the required price items for which you can define ancillary pricing rules using the ancillary pricing rule type.
15. Add the price item parameters based on which you want to define the ancillary pricing, if required.
16. Define the characteristics for an ancillary pricing rule type, if required.
17. Define the required ancillary-specific additional data in the ancillary pricing rule type.
18. Define the pricing arrangements for an ancillary pricing rule type, if required.
19. Click **Save**.

The ancillary pricing rule type is defined.

### **Related Topics**

For more information on...	See...
How to add the related pricing rule types in the primary pricing rule type	<a href="#">Adding Related Pricing Rule Types in a Primary Pricing Rule Type</a>
How to define the transaction field mapping in the primary pricing rule type	<a href="#">Defining Transaction Field Mapping in a Primary Pricing Rule Type</a>
How to associate algorithms with the pricing rule type	<a href="#">Associating Algorithms with a Pricing Rule Type</a>
How to define additional data for the pricing rule type	<a href="#">Defining Additional Data for a Pricing Rule Type</a>
How to add pricing items in the pricing rule type	<a href="#">Adding Price Items in a Pricing Rule Type</a>
How to add price item parameters in the pricing rule type	<a href="#">Adding a Price Item Parameter in a Pricing Rule Type</a>
How to define characteristics for the pricing rule type	<a href="#">Defining Characteristics for a Pricing Rule Type</a>
How to define ancillary-specific data in the pricing rule type	<a href="#">Defining the Ancillary-Specific Data in an Ancillary Pricing Rule Type</a> on page 2582

For more information on...	See...
How to define pricing arrangements for the pricing rule type	<a href="#">Defining Pricing Arrangements in an Ancillary Pricing Rule Type</a> on page 2584

## Adding a Related Pricing Rule Type in an Ancillary Pricing Rule Type

The **Administrative Services Only (ASO)** feature is designed in such a way that all non-primary pricing rule types should inherit the transaction field mapping details from a primary pricing rule type. These non-primary pricing rule types are added in a primary pricing rule type as the related pricing rule types.

### Prerequisites

To add related pricing rule types in an ancillary pricing rule type, you should have:

- Aggregate Stop Loss pricing rule type defined in the application.
- Specific Stop Loss pricing rule type defined in the application.
- Level Funding pricing rule type defined in the application.
- Rule types defined in the application (where the rule type usage is set to **Related Pricing Rule Type Eligibility**)

### Procedure



To add related pricing rule type in an ancillary pricing rule type:

1. Ensure that the **Related Pricing Rule Types** section is expanded when you are defining or editing an ancillary pricing rule type.

**Note:** The **Related Pricing Rule Types** section appears only when the **Primary** option is selected in the **Main** section.

The **Related Pricing Rule Types** section contains the following columns in a grid:

Column Name	Column Description	Mandatory (Yes or No)
Sequence	Used to specify the order in which the related pricing rule type should be invoked.	Yes (Conditional)
		<b>Note:</b> This field is required when you are adding a related pricing rule type in the ancillary pricing rule type.

Column Name	Column Description	Mandatory (Yes or No)
Pricing Rule Type	<p>Used to indicate the non-primary pricing rule type which should inherit the transaction field mapping details from the claim pricing rule type. You can add a non-primary pricing rule type of the following categories in the claim pricing rule type:</p> <ol style="list-style-type: none"> <li>1. Retention Type Claim Based</li> <li>2. Discount Arrangement</li> <li>3. Specific Stop-Loss</li> <li>4. Aggregate Stop-Loss</li> <li>5. Level Funding</li> </ol> <p><b>Note:</b> We recommend you to add the required related pricing rule types in the above specified sequence. Otherwise, erroneous results might occur.</p> <p>The <b>Search</b>  icon appears corresponding to the <b>Pricing Rule Type</b> field.. On clicking the <b>Search</b>  icon corresponding to the <b>Pricing Rule Type</b> field, the <b>Pricing Rule Type Search</b> window appears.</p> <p>On specifying the pricing rule type, the description of the pricing rule type appears corresponding to the <b>Pricing Rule Type</b> field.</p>	<p>Yes (Conditional)</p> <p><b>Note:</b> This field is required when the corresponding <b>Sequence</b> field is specified for the related pricing rule type.</p>
Eligibility Rule Type	<p>Used to specify the rule type which indicates the rules that should be executed to determine whether the related pricing rule type is eligible for deriving the transaction legs.</p> <p><b>Note:</b> The list includes only those rule types where the rule type usage is set to <b>Related Pricing Rule Type Eligibility</b>.</p>	No

2. Enter the required details in the **Related Pricing Rule Types** section.
3. If you want to define more than one related pricing rule type for the ancillary pricing rule type, click the **Add**  icon and then repeat step 2.

**Note:** However, if you want to remove a related pricing rule type from the ancillary pricing rule type, click the **Delete**  icon corresponding to the related pricing rule type.

4. Click **Save**.

The related pricing rule type is added in the ancillary pricing rule type.

#### **Related Topics**

For more information on...	See...
How to define an ancillary pricing rule type	<a href="#">Defining an Ancillary Pricing Rule Type</a> on page 2561

<b>For more information on...</b>	<b>See...</b>
How to edit an ancillary pricing rule type	<a href="#">Editing an Ancillary Pricing Rule Type</a> on page 2586

## Mapping the Transaction Field in an Ancillary Pricing Rule Type

### Prerequisites

To map the transaction field mapping for an ancillary pricing rule type, you should have:

- Transaction fields defined in the application

### Procedure

To map the transaction field mapping for an ancillary pricing rule type:

1. Ensure that the **Transaction Field Mapping** section is expanded when you are defining an ancillary pricing rule type.

#### **Note:**

This section appears only when you have chosen the **Primary** option from the **Main** section.

The **Transaction Field Mapping** section contains the following fields:

Field Name	Field Description	Mandatory (Yes or No)
Source System	Used to map to a transaction field which indicates the external system from where the ancillary transaction is received. The information stored in this field is then used for deriving the bill group, parent customer, and policy for the ancillary transaction.	Yes
Parameter 1	Used to map to a transaction field which indicates the employee attribute based on which you want to derive the bill group.	Yes
Parameter 2	Used to map to a transaction field which indicates the employee attribute based on which you want to derive the bill group.	Yes (Conditional) <b>Note:</b> This field is required when you want to derive the bill group using multiple employee attributes.
Parameter 3	Used to map to a transaction field which indicates the employee attribute based on which you want to derive the bill group.	Yes (Conditional) <b>Note:</b> This field is required when you want to derive the bill group using multiple employee attributes.
Parameter 4	Used to map to a transaction field which indicates the employee attribute based on which you want to derive the bill group.	Yes (Conditional) <b>Note:</b> This field is required when you want to derive the bill group using multiple employee attributes.



Field Name	Field Description	Mandatory (Yes or No)
Incurred Date	Used to map to a transaction field which contains the date when the healthcare service was availed by the employee.	Yes (Conditional) <b>Note:</b> This field is required when you want to fetch an effective specific stop-loss or aggregate stop-loss pricing rule for the claim transaction.
Paid Date	Used to map to a transaction field which contains the date when the claim amount was paid to the employee.	Yes (Conditional) <b>Note:</b> This field is required when you want to fetch an effective specific stop-loss or aggregate stop-loss pricing rule for the ancillary transaction.
Source of Funds	Used to map to a transaction field which indicates the source of funding. At present, this field is not used in the system.	No
Composite	Used to map to a transaction field which indicates whether the employee is covered under the composite insurance.	No
Claim Disposition	Used to map to a transaction field which helps to determine how the claim based fees should be charged for the positive and negative claim transactions.	Yes (Conditional) <b>Note:</b> This field is required while calculating the retention type claim based fees for the claim transaction.
Provider's Tax Identification Number	Used to map to a transaction field which states the healthcare provider's identification number. The information stored in this field is then used to determine whether the healthcare provider is excluded from the specific stop-loss coverage.	Yes (Conditional) <b>Note:</b> This field is required while calculating specific stop-loss for the ancillary transaction.
Member ID	Used to map to a transaction field which states the member's identification number. The information stored in this field is then used to determine whether the member is excluded from the specific stop-loss coverage.	Yes (Conditional) <b>Note:</b> This field is required while calculating specific stop-loss for the ancillary transaction.
Main Subscriber ID	Used to map to a transaction field which states the main subscriber's identification number. The information stored in this field is then used to determine whether the main subscriber is excluded from the specific stop-loss coverage.	Yes (Conditional) <b>Note:</b> This field is required while calculating specific stop-loss for the ancillary transaction.

Field Name	Field Description	Mandatory (Yes or No)
Run-in Identifier	Used to map to a transaction field which indicates whether the ancillary transaction is a run-in ancillary transaction.	Yes (Conditional) <b>Note:</b> This field is required while defining a ancillary pricing rule type.
Runout Identifier	Used to map to a transaction field which indicates whether the ancillary transaction is a runout ancillary transaction. At present, this field is not used in the system.	No
Third Party Identifier	Used to specify the third party identifier to determine that the ancillary transaction is received from an external source system while defining an ancillary pricing rule type.	No
Coverage Start Date	Used to map to a transaction field which indicates the coverage start date. The information stored in this field is then used to fetch an effective retention type enrollment based pricing rule for a non-retroactive enrollment transaction.	Yes (Conditional) <b>Note:</b> This field is required while defining a retention type enrollment based pricing rule type.
Coverage End Date	Used to map to a transaction field which indicates the coverage end date. The information stored in this field is then used to fetch an effective retention type enrollment based pricing rule for a retroactive enrollment transaction.	Yes (Conditional) <b>Note:</b> This field is required while defining a retention type enrollment based pricing rule type.
Retroactivity Indicator	Used to map to a transaction field which indicates whether the enrollment transaction is a retroactive enrollment transaction.	Yes (Conditional) <b>Note:</b> This field is required while defining a retention type enrollment based pricing rule type.
Network Indicator	Used to map to a transaction field which indicates whether the service provider is in network or out of network.	Yes (Conditional) <b>Note:</b> This field is required while defining a discount arrangement pricing rule.
Covered Charge Amount	Used to map to a transaction field which indicates the amount which is covered for the employee in the policy.	Yes (Conditional) <b>Note:</b> This field is required while calculating the discount using a discount guarantee pricing rule.

Field Name	Field Description	Mandatory (Yes or No)
Discount Savings Amount	Used to map to a transaction field which indicates the amount which is offered as the discount to the service provider.	Yes (Conditional) <b>Note:</b> This field is required while calculating the discount using a discount guarantee or discount share pricing rule.
Accumulation Only Identifier	Used to map to a transaction field which indicates that the ancillary transaction should only be used for calculating charges for the accumulated products, such as Specific Stop-Loss, Aggregate Stop-Loss, and so on. This means that the system should not derive the ancillary transaction leg. Instead, it should only derive the specific stop-loss or aggregate stop loss transaction legs for the ancillary transaction.	No
Billing Eligibility Identifier	Used to map to a transaction field which indicates whether the ancillary transaction is eligible for billing.	Yes (Conditional) <b>Note:</b> This field is required while defining an ancillary pricing rule type.
Transaction Upload Date	Used to map to a transaction field which indicates the date when the transaction was uploaded in the external system. The system does not derive the discount transaction leg when the transaction upload date is later than the settlement date.	Yes (Conditional) <b>Note:</b> This field is required while calculating the discount using a discount guarantee or discount share pricing rule.

**Note:**

The **Search**  icon appears corresponding to each field. On clicking the **Search** icon, the **Transaction Field Search** window appears.

On specifying the transaction field, the description of the transaction field appears corresponding to the respective field.

2. Enter the required details in the **Transaction Field Mapping** section.
3. Click **Save**.

The transaction fields are mapped to the appropriate fields in the claim pricing rule type.

### **Related Topics**

For more information on...	See...
How to define an ancillary pricing rule type	<a href="#">Defining an Ancillary Pricing Rule Type</a> on page 2561
How to edit an ancillary pricing rule type	<a href="#">Editing an Ancillary Pricing Rule Type</a> on page 2586

## Associating an Algorithm with an Ancillary Pricing Rule Type

### Prerequisites

To associate algorithms with an ancillary pricing rule type, you should have:

- Algorithms defined using the **C1\_TXNBGDRV**, **C1\_ACCPRIDRV**, and **C1\_BAFTDRV** algorithm types.



### Procedure

To associate an algorithm with an ancillary pricing rule type:

1. Ensure that the **Algorithms** section is expanded when you are defining or editing an ancillary pricing rule type.

The **Algorithms** section contains the following columns in a grid:

Column Name	Column Description	Mandatory (Yes or No)
System Event	<p>Used to indicate the system event when you want to invoke the algorithm. The valid values are:</p> <ul style="list-style-type: none"> <li>• <b>Account and Price Item Derivation</b> - Used to derive the account and price item for the ancillary transaction.</li> <li>• <b>Accumulation Billable Charge Post Proc</b> - Used to introduce a custom logic after creating discount share or discount guarantee billable charges. This algorithm is invoked in the <b>C1-BCDA (Create Billable Charge for Discount)</b> batch.</li> <li>• <b>Accumulation Billable Charge Pre Proc</b> - Used to introduce a custom logic before creating discount share or discount guarantee billable charges. This algorithm is invoked in the <b>C1-BCDA (Create Billable Charge for Discount)</b> batch.</li> <li>• <b>Accumulation Post Processing</b> - Used to introduce a custom logic after accumulating the discount share or discount guarantee amount. This algorithm is invoked in the <b>C1-ACDA (Accumulate Discount Arrangement)</b> batch.</li> <li>• <b>Accumulation Pre Processing</b> - Used to introduce a custom logic before accumulating the discount share or discount guarantee amount. This algorithm is invoked in the <b>C1-ACDA (Accumulate Discount Arrangement)</b> batch.</li> <li>• <b>Bill After Date Determination</b> - Used to determine the bill after date for the ancillary transaction.</li> <li>• <b>Bill Group Derivation</b> - Used to derive the bill group, parent customer, and policy for the ancillary transaction.</li> <li>• <b>Pricing Rule Post Processing</b> - Used to introduce a custom logic once the effective ancillary pricing rule is derived for the ancillary transaction.</li> <li>• <b>Transaction Validation</b> - Used to introduce a custom validation for the ancillary transaction.</li> </ul> <p><b>Note:</b> You must specify <b>Account and Price Item Derivation</b> and <b>Bill Group Derivation</b> algorithms when you are associating the algorithms with an ancillary pricing rule type.</p>	<p>Yes</p> <p><b>Note:</b> This field is required when you are associating an algorithm with the ancillary pricing rule type.</p>
Sequence	<p>Used to specify the order in which the algorithms with the same system event should be executed.</p>	<p>Yes (Conditional)</p> <p><b>Note:</b> This field is required when you are associating an algorithm with the ancillary pricing rule type.</p>

Column Name	Column Description	Mandatory (Yes or No)
Algorithm	<p>Used to indicate the algorithm that you want to execute on the system event.</p> <p><b>Note:</b></p> <p>Once you select the system event, the <b>Search</b>  icon appears corresponding to the <b>Algorithm</b> field. On clicking the <b>Search</b>  icon, the <b>Algorithm Search</b> window appears.</p> <p>On specifying the algorithm, the description of the algorithm appears corresponding to the <b>Algorithm</b> field.</p>	<p>Yes (Conditional)</p> <p><b>Note:</b> This field is required when you are associating an algorithm with the ancillary pricing rule type.</p>

2. Enter the required details in the **Algorithms** section:

System Event	Algorithm	Mandatory (Yes or No)	For more information, see...
Account and Price Item Derivation	C1_ACCPRIDRV	Yes	<a href="#">Account and Price Item Derivation (for the Claim Pricing Rule Type Category)</a> on page 2736
Accumulation Billable Charge Post Proc	- <b>Note:</b> An accumulation billable charge post processing algorithm type is not shipped with the product. You can create a custom algorithm type, if required.	No	-
Accumulation Billable Charge Pre Proc	- <b>Note:</b> An accumulation billable charge pre processing algorithm type is not shipped with the product. You can create a custom algorithm type, if required.	No	-
Accumulation Post Processing	- <b>Note:</b> An accumulation post processing algorithm type is not shipped with the product. You can create a custom algorithm type, if required.	No	-
Accumulation Pre Processing	- <b>Note:</b> A accumulation pre processing algorithm type is not shipped with the product. You can create a custom algorithm type, if required.	No	-
Bill After Date Determination	C1_BAFTDRV	Yes	<a href="#">Bill After Date Determination</a> on page 2785

System Event	Algorithm	Mandatory (Yes or No)	For more information, see...
Bill Group Derivation	C1_TXNBGDRV	Yes	<a href="#">Bill Group Derivation</a> on page 2733
Pricing Rule Post Processing	- <b>Note:</b> A pricing rule post processing algorithm type is not shipped with the product. You can create a custom algorithm type, if required.	No	-
Transaction Validation	- <b>Note:</b> An algorithm type for validating an ancillary transaction is not shipped with the product. You can create a custom algorithm type, if required.	No	-

3. If you want to associate more than one algorithm with an ancillary pricing rule type, click the **Add** (+) icon and then repeat step 2.

**Note:** However, if you want to remove an algorithm from the ancillary pricing rule type, click the **Delete** (🗑️) icon corresponding to the algorithm.

4. Click **Save**.

The algorithms are associated with an ancillary pricing rule type.

### Related Topics

For more information on...	See...
How to define an ancillary pricing rule type	<a href="#">Defining an Ancillary Pricing Rule Type</a> on page 2561
How to edit an ancillary pricing rule type	<a href="#">Editing an Ancillary Pricing Rule Type</a> on page 2586

## Defining Additional Data in an Ancillary Pricing Rule Type

### Procedure

To define additional data in an ancillary pricing rule type:



1. Ensure that the **Additional Data** section is expanded when you are defining or editing an ancillary pricing rule type.

**Note:** This section does not appear only when the **Pricing Rule Type Category** is **Flat Fees**.

The **Additional Data** section contains the following fields:

Field Name	Field Description	Mandatory (Yes or No)
Eligible for Specific Stop-Loss	<p>Used to indicate whether the price items included in the ancillary pricing rule type are eligible for specific stop-loss. The valid values are:</p> <ul style="list-style-type: none"> <li>• Yes</li> <li>• No</li> </ul> <div style="border: 1px solid black; padding: 5px; margin-top: 10px;"> <p><b>Note:</b></p> <p>This field appears only when the <b>Pricing Rule Type Category</b> is either <b>Ancillary, Claim, Retention Type Claim Based,</b> or <b>Retention Type Enrollment Based.</b></p> <p>If you do not specify the value for this field, by default, it is set to <b>No</b></p> </div>	No
Eligible for Level Funding	<p>Used to indicate whether the price items included in the ancillary pricing rule type are eligible for level funding. The valid values are:</p> <ul style="list-style-type: none"> <li>• Yes</li> <li>• No</li> </ul>	No
Run-in Identifier Value	Used to specify the identifier value to determine whether the ancillary transaction is received during the run-in period of the policy.	No
Third Party Identifier Value	Used to specify the identifier value to determine whether the ancillary transaction is received from an external source system.	No
Accumulation Only Identifier Value	Used to specify the value when received in an ancillary transaction indicates that the ancillary transaction should only be considered for calculating specific stop-loss and aggregate stop-loss. In such case, a transaction leg is not derived for the ancillary transaction.	No
Eligible for Write-Off in Post Runout	<p>Used to indicate whether the pricing rule is eligible for Write-Off in Post Runout or not. The valid values are:</p> <ul style="list-style-type: none"> <li>• Yes</li> <li>• No</li> </ul> <p>For more information, refer to the <a href="#">Write-Off Charges during Post Runout</a> section.</p> <div style="border: 1px solid black; padding: 5px; margin-top: 10px;"> <p><b>Note:</b> By default, the value is set to <b>No.</b></p> </div>	No



Field Name	Field Description	Mandatory (Yes or No)
Post Runout Write-Off Adjustment Type	<p>Used to specify the adjustment type using which the post runout write-off adjustments must be created.</p> <p><b>Note:</b></p> <p>This field appears when the <b>Eligible for Write-Off in Post Runout</b> field is set to <b>Yes</b>.</p> <p>The <b>Search</b>  icon appears corresponding to the <b>Post Runout Write-Off Adjustment Type</b> field. On clicking the <b>Search</b> icon, the <b>Adjustment Type Search</b> window appears.</p> <p>On specifying the adjustment type, the description of the adjustment type appears corresponding to the <b>Eligible for Write-Off in Post Runout</b> field.</p>	<p>Yes (Conditional)</p> <p><b>Note:</b> This field is required when the <b>Eligible for Write-Off in Post Runout</b> field is set to <b>Yes</b>.</p>
Rule Based Price Item Eligibility Field	<p>Used to indicate the transaction field which you want to use in the rules as the output parameter to determine whether the price item should be considered for billing. For more information, refer to the <a href="#">Price Item Eligibility</a> on page 2726.</p> <p><b>Note:</b></p> <p>This field appears when the <b>Eligible for Write-Off in Post Runout</b> field is set to <b>Yes</b>.</p> <p>The <b>Search</b>  icon appears corresponding to the <b>Rule Based Price Item Eligibility Field</b> field. On clicking the <b>Search</b> icon, the <b>Field Search</b> window appears.</p> <p>On specifying the field name, the description of the field name appears corresponding to the <b>Rule Based Price Item Eligibility Field</b>.</p>	No
Rule Based Related Pricing Rule Type Eligibility Field	<p>Used to indicate the transaction field which you want to use in the rules as the output parameter to determine whether the related pricing rule type should be considered for deriving the transaction legs. For more information, refer to <a href="#">Related Pricing Rule Type Eligibility</a> on page 2724.</p> <p><b>Note:</b></p> <p>The <b>Search</b>  icon appears corresponding to the <b>Rule Based Related Pricing Rule Type Eligibility Field</b> field. On clicking the <b>Search</b> icon, the <b>Field Search</b> window appears.</p> <p>On specifying the field, the description of the field appears corresponding to the <b>Rule Based Related Pricing Rule Type Eligibility Field</b> field.</p>	No

Field Name	Field Description	Mandatory (Yes or No)
Rule Based Eligibility Value	Used to specify the value which the output parameter in the rule should return when the price item and related pricing rule type in the ancillary pricing rule type should be considered for processing.	Yes (Conditional)  <b>Note:</b> This field is required when a value is specified in the <b>Rule Based Price Item Eligibility Field</b> or <b>Rule Based Related Pricing Rule Type Eligibility Field</b> field.

2. Enter the required details in the **Additional Data** section.
3. Click **Save**.

The additional data is defined in the ancillary pricing rule type.

#### Related Topics

For more information on...	See...
How to define an ancillary pricing rule type	<a href="#">Defining an Ancillary Pricing Rule Type</a> on page 2561
How to edit an ancillary pricing rule type	<a href="#">Editing an Ancillary Pricing Rule Type</a> on page 2586

## Adding a Price Item in an Ancillary Pricing Rule Type

### Prerequisites

To add a price item in an ancillary pricing rule type, you should have:





- Price item defined in the application
- Rate options defined in the **Rate Option (C1-ExtLookRetTypeRateOpt)** extendable lookup
- Values defined for the **Invoice Type (C1INVTYP)** characteristic type
- The **C1INVTYP** characteristic type set in the **Invoice Type Characteristic Type** option type of the **C1-ASOBLNG** feature configuration
- Rule types defined in the application (where the rule type usage is set to **Price Item Eligibility**)





### Procedure

To add a price item in an ancillary pricing rule type:

1. Ensure that the **Price Items** section is expanded when you are defining or editing an ancillary pricing rule type.

The **Price Items** section contains the following fields in a grid:

Field Name	Field Description	Mandatory (Yes or No)						
Price Item	<p>Used to indicate the price item that you want to include in an ancillary pricing rule type.</p> <p><b>Note:</b></p> <p>The <b>Search</b> () icon appears corresponding to the <b>Price Item</b> field. On clicking the <b>Search</b> () icon, the <b>Price Item Search</b> window appears.</p> <p>On specifying the price item, the description of the price item appears corresponding to the <b>Price Items</b> field.</p>	<p>Yes (Conditional)</p> <p><b>Note:</b> This field is required when you are adding a rate option and bill to account in the discount arrangement pricing rule type.</p>						
Rate Option	<p>Used to indicate one or more rate options which are valid for a price item.</p> <p>On clicking the <b>Add</b> () icon, the following field appears in a grid:</p> <table border="1" data-bbox="462 714 1227 913"> <thead> <tr> <th data-bbox="462 714 602 793">Field Name</th> <th data-bbox="602 714 1031 793">Field Description</th> <th data-bbox="1031 714 1227 793">Mandatory (Yes or No)</th> </tr> </thead> <tbody> <tr> <td data-bbox="462 793 602 913">Rate Option</td> <td data-bbox="602 793 1031 913">Used to indicate the rate option that you want to use while defining pricing for the price item.</td> <td data-bbox="1031 793 1227 913">Yes</td> </tr> </tbody> </table> <p><b>Note:</b></p> <p>If you want to define more than one rate option to the price item in an ancillary pricing rule type, click the <b>Add</b> () icon.</p> <p>However, if you want to remove a price item from an ancillary pricing rule type, click the <b>Delete</b> () icon corresponding to the <b>Rate Option</b> field.</p>	Field Name	Field Description	Mandatory (Yes or No)	Rate Option	Used to indicate the rate option that you want to use while defining pricing for the price item.	Yes	Not applicable
Field Name	Field Description	Mandatory (Yes or No)						
Rate Option	Used to indicate the rate option that you want to use while defining pricing for the price item.	Yes						

Field Name	Field Description	Mandatory (Yes or No)									
Bill To Account	<p>Used to indicate a order in which the account should be considered while deriving a transaction leg.</p> <p>On clicking the <b>Add</b> () icon, the following fields appear in a grid:</p> <table border="1"> <thead> <tr> <th>Field Name</th> <th>Field Description</th> <th>Mandatory (Yes or No)</th> </tr> </thead> <tbody> <tr> <td>Priority</td> <td>Used to specify the order in which the invoice type is considered for a price item.</td> <td>Yes</td> </tr> <tr> <td>Invoice Type</td> <td>Used to indicate the type which is considered for billing. For more information, refer to the <a href="#">Bill Group's Account</a> on page 55 section.</td> <td>Yes</td> </tr> </tbody> </table> <p><b>Note:</b> The <b>Search</b> () icon appears corresponding to the <b>Invoice Type</b> field. On clicking the <b>Search</b> icon, the <b>Invoice Type Search</b> window appears.</p> <p><b>Note:</b> If you want to define more than one invoice type to the price item in an ancillary pricing rule type, click the <b>Add</b> () icon. However, if you want to remove a invoice type from the price item in an ancillary pricing rule type, click the <b>Delete</b> () icon corresponding to the <b>Priority</b> field.</p>	Field Name	Field Description	Mandatory (Yes or No)	Priority	Used to specify the order in which the invoice type is considered for a price item.	Yes	Invoice Type	Used to indicate the type which is considered for billing. For more information, refer to the <a href="#">Bill Group's Account</a> on page 55 section.	Yes	Not applicable
Field Name	Field Description	Mandatory (Yes or No)									
Priority	Used to specify the order in which the invoice type is considered for a price item.	Yes									
Invoice Type	Used to indicate the type which is considered for billing. For more information, refer to the <a href="#">Bill Group's Account</a> on page 55 section.	Yes									
Eligibility Rule Type	Used to indicate the rule type which indicates the rules that should be executed to determine whether the price item is eligible for billing.	No									

- Enter the required details in the **Price Items** section.
- If you want to define more than one price item for an ancillary pricing rule type, click the **Add** () icon and then repeat step 2.

**Note:** However, if you want to remove a price item from an ancillary pricing rule type, click the **Delete** () icon corresponding to the price item.

- Click **Save**.

The price items are added for an ancillary pricing rule type.

### Related Topics

For more information on...	See...
How to define an ancillary pricing rule type	<a href="#">Defining an Ancillary Pricing Rule Type</a> on page 2561

<b>For more information on...</b>	<b>See...</b>
How to edit an ancillary pricing rule type	<a href="#">Editing an Ancillary Pricing Rule Type</a> on page 2586

## Adding a Price Item Parameter in an Ancillary Pricing Rule Type

### Prerequisites

To add a price item parameter in an ancillary pricing rule type, you should have:

- Parameters defined in the application where parameter usage is set to **Price Item**.
- Parameters associated with the price item.
- Billable Charge Line Type Parameter** and **Pricing Arrangement Parameter** defined in the application.
- Billable Charge Line Type Parameter** and **Pricing Arrangement Parameter** set as option types in the **C1-ASOBLLNG** feature configuration.
- Transaction fields defined in the application.

### Procedure

To add a price item parameter in an ancillary pricing rule type:

1. Ensure that the **Price Item Parameters** section is expanded when you are defining or editing an ancillary pricing rule type.

The **Price Item Parameters** section contains the following fields in a grid:

Field Name	Field Description	Mandatory (Yes or No)
Price Item Parameter	Used to specify the parameter which you can use while defining an ancillary pricing for the price item.  <b>Note:</b> The <b>Search</b> (🔍) icon appears corresponding to the <b>Price Item Parameter</b> field. On clicking the <b>Search</b> (🔍) icon corresponding to the <b>Price Item Parameter</b> field, the <b>Parameter Search</b> window appears.  On specifying the parameter, the description of the price item parameter appears corresponding to the <b>Price Item Parameter</b> field.	Yes (Conditional)  <b>Note:</b> This field is required while adding a price item parameter in an ancillary pricing rule type.
Transaction Field	Used to map to a transaction field which contains the parameter value.  <b>Note:</b> The <b>Search</b> (🔍) icon appears corresponding to the <b>Transaction Field</b> field. On clicking the <b>Search</b> (🔍) icon corresponding to the <b>Transaction Field</b> field, the <b>Transaction Field Search</b> window appears.  On specifying the transaction field, the description of the transaction field appears corresponding to the <b>Transaction Field</b> .	Yes (Conditional)  <b>Note:</b> This field is required while adding a price item parameter in an ancillary pricing rule type.

Field Name	Field Description	Mandatory (Yes or No)
Eligible for Specific Stop-Loss	Used to indicate whether the price item parameter can be used while defining the accumulation criteria in the specific stop-loss or aggregate stop-loss pricing rules at the bill group level.	No
Eligible for Level Funding	Used to indicate whether the price item parameter can be used while defining the accumulation criteria in the level-funding pricing rules at the bill group level.	No

- Enter the required details in the **Price Item Parameters** section.
- If you want to add more than one price item parameter for an ancillary pricing rule type, click the **Add** (+) icon and then repeat step 2.

**Note:** However, if you want to remove a price item parameter from an ancillary pricing rule type, click the **Delete** (🗑️) icon corresponding to the price item parameter.

- Click **Save**.

The price item parameter is added in the ancillary pricing rule type.

#### Related Topics

For more information on...	See...
How to define an ancillary pricing rule type	<a href="#">Defining an Ancillary Pricing Rule Type</a> on page 2561
How to edit an ancillary pricing rule type	<a href="#">Editing an Ancillary Pricing Rule Type</a> on page 2586

## Defining the Ancillary-Specific Data in an Ancillary Pricing Rule Type



### Procedure

To add the ancillary-specific additional data in an ancillary pricing rule type:

- Ensure that the **Ancillary-Specific Additional Data** section is expanded when you are defining or editing an ancillary pricing rule type.

The **Ancillary-Specific Additional Data** section contains the following fields:

Field Name	Field Description	Mandatory (Yes or No)
Billing Eligibility Identifier Value	Used to specify the billing eligibility identifiers which help to determine whether the ancillary transaction is eligible for billing.	Yes (Conditional) <b>Note:</b> This field is required when you are adding the ancillary-specific additional data.
Billing Non-Eligibility Identifier Value	Used to specify the billing non-eligibility identifiers which help to determine whether the ancillary transaction is eligible for billing.	Yes (Conditional) <b>Note:</b> This field is required when you are adding the ancillary-specific additional data.

Field Name	Field Description	Mandatory (Yes or No)
Rule Based Markup or Markdown Eligibility Field	<p>Used to specify the transaction field that you want to use in the rules as the output parameter to determine whether the markup or markdown calculation line is eligible for billing.</p> <p><b>Note:</b></p> <p>On clicking the <b>Search</b>  icon corresponding to the <b>Rule Based Markup or Markdown Eligibility Field</b> field, the <b>Field Search</b> window appears.</p> <p>On specifying the field, the description of the field appears corresponding to the <b>Rule Based Markup or Markdown Eligibility Field</b> field.</p>	<p>Yes (Conditional)</p> <p><b>Note:</b> This field is required when the Markup or Markdown Eligibility Rule Type field is specified.</p>
Markup or Markdown Billable Charge Line Type	<p>Used to specify the billable charge line type using which you want to create the billable charges for markup and markdown.</p> <p><b>Note:</b></p> <p>On clicking the <b>Search</b>  icon corresponding to the <b>Markup or Markdown Billable Charge Line Type</b> field, the <b>Billable Charge Line Type Search</b> window appears.</p> <p>On specifying the billable charge line type, the description of the billable charge line type appears corresponding to the <b>Markup or Markdown Billable Charge Line Type</b> field.</p>	No
Markup or Markdown Eligibility Rule Type	<p>Used to specify the markup or markdown eligibility rule type for the ancillary pricing rule type. The valid values are:</p> <ul style="list-style-type: none"> <li>• Rule 1</li> </ul> <p><b>Note:</b> The <b>Markup or Markdown Eligibility Rule Type</b> list includes only those rule-types where the rule type eligibility is <b>ASO Billing Mark Up / Down Eligibility</b>.</p>	No

2. Enter the required details in the **Ancillary-Specific Additional Data** section.
3. Define pricing arrangements for ancillary-specific data in the **Ancillary-Specific Additional Data** section.
4. Click **Save**.

The ancillary-specific additional data is added in the ancillary pricing rule type.

### Related Topics

For more information on...	See...
How to define an ancillary pricing rule type	<a href="#">Defining an Ancillary Pricing Rule Type</a> on page 2561

For more information on...	See...
How to edit an ancillary pricing rule type	<a href="#">Editing an Ancillary Pricing Rule Type</a> on page 2586
How to define pricing arrangements in an ancillary pricing rule type	<a href="#">Defining Pricing Arrangements in an Ancillary Pricing Rule Type</a> on page 2584

## Defining Pricing Arrangements in an Ancillary Pricing Rule Type

### Prerequisites

To define pricing arrangements in an ancillary pricing rule type, you should have:

- Line Items where category is set to **Ancillary**, as defined in the application.

### Procedure

To add pricing arrangements in an ancillary pricing rule type:

1. Ensure that the **Ancillary-Specific Data** and **Pricing Arrangements** section is expanded when you are defining or editing a pricing rule type.

The **Pricing Arrangements** section contains the following columns in a grid:

Column Name	Column Description	Mandatory (Yes or No)
Pricing Arrangement Identifier	Used to indicate the pricing arrangement identifier that you can define through an ancillary pricing rule type. The valid values are: <ul style="list-style-type: none"> <li>Pass Through (Markup or Markdown Optional)</li> <li>Pass Through without Markup or Markdown</li> <li>Rate Based (Markup or Markdown Optional)</li> </ul>	Yes (Conditional) <b>Note:</b> This field is required when you are defining pricing arrangements for an ancillary pricing rule type.
Pricing Arrangement Identifier Value	Used to specify the value for the pricing arrangement identifier. The valid values are: <ul style="list-style-type: none"> <li>Pass Through (Markup or Markdown Optional)</li> <li>Pass Through without Markup or Markdown</li> <li>Rate Based (Markup or Markdown Optional)</li> </ul>	Yes (Conditional) <b>Note:</b> This field is required when you are defining pricing arrangements for an ancillary pricing rule type.
Line Item	Used to indicate the line item which using the billable charge is created for a pricing arrangement.	Yes (Conditional) <b>Note:</b> This field is required when you are defining pricing arrangements for an ancillary pricing rule type.

2. Enter the required details in the **Pricing Arrangements** section.
3. If you want to define more than one pricing arrangement in an ancillary pricing rule type, click the **Add** (+) icon and then repeat step 2.

**Note:** However, if you want to remove a pricing arrangement from the ancillary pricing rule type, click the **Delete** (🗑️) icon corresponding to the pricing arrangement identifier.

4. Click **Save**.

The pricing arrangements are defined for the ancillary pricing rule type.



**Related Topics**

For more information on...	See...
How to define an ancillary pricing rule type	<a href="#">Defining an Ancillary Pricing Rule Type</a> on page 2561
How to edit an ancillary pricing rule type	<a href="#">Editing an Ancillary Pricing Rule Type</a> on page 2586

**Defining a Characteristic for a Ancillary Pricing Rule Type****Prerequisites**

To define a characteristic for an ancillary pricing rule type, you should have:

- Characteristic types defined in the application (where the characteristic entity is set to **Pricing Rule Type**)

**Procedure**

To define a characteristic for an ancillary pricing rule type:

1. Ensure that the **Characteristics** section is expanded when you are defining an ancillary pricing rule type.

The **Characteristics** section contains the following fields in a grid:

Field Name	Field Description	Mandatory (Yes or No)
Characteristic Type	Used to indicate the characteristic type. <b>Note:</b> The list includes only those characteristic types where the characteristic entity is set to <b>Pricing Rule Type</b> .	Yes (Conditional) <b>Note:</b> This field is required when you are defining a characteristic for an ancillary pricing rule type.
Characteristic Value	Used to specify the value for the characteristic type. <b>Note:</b> If you select a predefined characteristic type, the <b>Search</b>  icon appears corresponding to the <b>Characteristic Value</b> field. On clicking the <b>Search</b> icon, the <b>Predefined Characteristic Search</b> window appears.  On specifying the value for a predefined characteristic type, the description of the characteristic value appears corresponding to the <b>Characteristic Value</b> field.	Yes (Conditional) <b>Note:</b> This field is required when you are defining a characteristic for an ancillary pricing rule type.

2. Enter the required details in the **Characteristics** section.
3. If you want to define more than one characteristic for an ancillary pricing rule type, click the **Add**  icon and then repeat step 2.

**Note:** However, if you want to remove a characteristic from an ancillary pricing rule type, click the **Delete**  icon corresponding to the characteristic.

4. Click **Save**.

The characteristic is defined for an ancillary pricing rule type.

### Related Topics

For more information on...	See...
How to define an ancillary pricing rule type	<a href="#">Defining an Ancillary Pricing Rule Type</a> on page 2561
How to edit an ancillary pricing rule type	<a href="#">Editing an Ancillary Pricing Rule Type</a> on page 2586

## Editing an Ancillary Pricing Rule Type

### Prerequisites

To edit an ancillary pricing rule type, you should have:

- Ancillary pricing rule type business object defined in the application.
- Ancillary pricing rule business object defined in the application.

### Procedure

To edit an ancillary pricing rule type:

1. Click the **Admin** link in the **Application** toolbar.  
A list appears.
2. From the **Admin** menu, select **P** and then click **Pricing Rule Type**.  
A sub-menu appears.
3. Click the **Search** option from the **Pricing Rule Type** sub-menu.  
The **Pricing Rule Type** screen appears.
4. In the **Pricing Rule Type List** zone, click the **Edit** (✎) icon in the **Edit** column corresponding to an ancillary pricing rule type whose details you want to edit.

The **Ancillary Pricing Rule Type** screen appears. It contains the following sections:

- **Main** – Used to specify basic details about the ancillary pricing rule type.
- **Related Pricing Rule Types** – Used to indicate the non-primary pricing rule types which should inherit the transaction field mapping details from the ancillary pricing rule type. You can add a pricing rule type which belongs to the following category:
  1. Retention Type Claim Based
  2. Discount Arrangement
  3. Specific Stop-Loss
  4. Aggregate Stop-Loss
  5. Level Funding

**Note:** We recommend you to add the required related pricing rule types in the above specified sequence. Otherwise, erroneous results might occur.

- **Transaction Field Mapping** – Used to map the transaction fields in a claim transaction to the appropriate fields in the claim pricing rule type. This helps the system to determine the field where the data from the

transaction field must be stored. This data is then used in the system for various reasons, such as for deriving a bill group and pricing, deriving an effective related pricing rule, and so on.

**Note:** The **Billing Eligibility Identifier** field is required when you are defining the **Transaction Field Mapping** for the ancillary pricing rule type.

- **Algorithms** – Used to associate the algorithms with the ancillary pricing rule type.
- **Additional Data** – Used to specify the additional information about the ancillary pricing rule type.
- **Price Items** – Used to add the price items for which you can define the ancillary pricing rules using the ancillary pricing rule type.
- **Price Item Parameters** – Used to add the price item parameters based on which you want to define the price item pricing.

**Note:** There are two price item parameters that are mandatory in the ancillary pricing rule type:

- A price item which stores the billable charge line type from the ancillary transaction.
- A price item which stores the pricing arrangement from the ancillary transaction.

- **Characteristics** – Used to define characteristics for the ancillary pricing rule type.
- **Ancillary-Specific Additional Data** – Used to define ancillary-specific additional data.

**Note:** Following fields are required when you are defining the **Ancillary-Specific Additional Data** for the ancillary pricing rule type.

- **Billing Eligibility Identifier Value**
- **Billing Non-Eligibility Identifier Value**

- **Pricing Arrangements** – Used to define the pricing arrangements for the ancillary pricing rule type.
  - **Pass Through (Markup or Markdown Optional)**
  - **Pass Through Without Markup or Markdown**
  - **Rate Based (Markup or Markdown Optional)**

The **Main** section contains the following fields:

Field Name	Field Description	Mandatory (Yes or No)
Pricing Rule Type	Displays the ancillary pricing rule type.	Not applicable
Description	Used to specify the description for an ancillary pricing rule type.	Yes
Detailed Description	Used to specify additional information about the ancillary pricing rule type.	No

Field Name	Field Description	Mandatory (Yes or No)
Pricing Rule Business Object	<p>Used to indicate the business object using which you want to create an ancillary pricing rule. The valid value is:</p> <ul style="list-style-type: none"> <li>• Aggregate Stop-Loss (ASL) Pricing Rule</li> <li>• Ancillary Pricing Rule</li> <li>• Claim Pricing Rule</li> <li>• Discount Arrangement Pricing Rule</li> <li>• Flat Fee Pricing Rule</li> <li>• Level Funded (LF) Pricing Rule</li> <li>• Retention Type Claim Based Pricing Rule</li> <li>• Retention Type Enrollment Based Pricing Rule</li> <li>• Specific Stop-Loss (SSL) Pricing Rule</li> </ul> <p><b>Note:</b> You must select the <b>Ancillary Pricing Rule</b> option from the <b>Pricing Rule Business Object</b> list while defining an ancillary pricing rule type.</p>	Yes
Business Object	Indicates the ancillary pricing rule type business object using which you are defining the ancillary pricing rule type.	Not applicable
Status	<p>Used to indicate the status of the ancillary pricing rule type. The valid values are:</p> <ul style="list-style-type: none"> <li>• Active</li> <li>• Inactive</li> </ul>	Yes
Primary	<p>Used to indicate whether the ancillary pricing rule type is a primary pricing rule type.</p> <p><b>Note:</b> This field is disabled when you select the <b>Flat Fees</b> option from the <b>Pricing Rule Type Category</b> list.</p>	No

Field Name	Field Description	Mandatory (Yes or No)
Pricing Rule Type Category	<p>Indicates the category to which the ancillary pricing rule type belongs. The valid values are:</p> <ul style="list-style-type: none"> <li>• Aggregate Stop-Loss</li> <li>• Ancillary</li> <li>• Claim</li> <li>• Discount Arrangement</li> <li>• Flat Fees</li> <li>• Level Funded</li> <li>• Retention Type Claim Based</li> <li>• Retention Type Enrollment Based</li> <li>• Specific Stop-Loss</li> </ul> <p><b>Note:</b> You must select the <b>Ancillary</b> option from the <b>Pricing Rule Type Category</b> list while defining an ancillary pricing rule type.</p>	No

**Tip:** Alternatively, you can edit the details of an ancillary pricing rule type by clicking the **Edit** button in the **Pricing Rule Type** zone to edit the pricing rule type for ancillary.

5. Modify the required details in the **Main** section, if required.
6. Ensure that the **Ancillary Pricing Rule** option is selected from the **Pricing Rule Business Object** list.
7. Ensure that the **Primary** option is selected in the **Main** section.
8. Add, edit, or remove the related pricing rule types in the ancillary pricing rule type, if required.

**Note:** The **Related Pricing Rule Types** section appears only when the **Primary** option is selected from the **Main** section.

9. Modify the transaction field mapping in the ancillary pricing rule type, if required.

**Note:** The **Transaction Field Mapping** section appears only when the **Primary** option is selected from the **Main** section.

10. Add, edit, or remove algorithms from the ancillary pricing rule type, if required.

System Event	Algorithm	Algorithm Type	Description
Account and Price Item Derivation	C1_ACCPRIDIS	C1_ACCPRIDIS	Account and Priceitem Derivation For Discount Arrangement

11. Edit generic additional data for the ancillary pricing rule type, if required.
12. Add, edit, or remove price items in an ancillary pricing rule type, if required.
13. Add, edit, or remove price item parameters in an ancillary pricing rule type, if required.
14. Add, edit, or remove characteristics in an ancillary pricing rule type, if required.
15. Modify the ancillary-specific data in an ancillary pricing rule type, if required.
16. Modify the pricing arrangements in an ancillary pricing rule type, if required.
17. Click **Save**.

The changes made to the ancillary pricing rule type are saved.

### **Related Topics**

<b>For more information on...</b>	<b>See...</b>
How to add related pricing rule type in an ancillary pricing rule type	<a href="#">Adding a Related Pricing Rule Type in an Ancillary Pricing Rule Type</a> on page 2566
How to map the transaction fields in an ancillary pricing rule type	<a href="#">Mapping the Transaction Field in an Ancillary Pricing Rule Type</a> on page 2568
How to associate an algorithm with an ancillary pricing rule type	<a href="#">Associating an Algorithm with an Ancillary Pricing Rule Type</a> on page 2572
How to defining additional data in an ancillary pricing rule type	<a href="#">Defining Additional Data in an Ancillary Pricing Rule Type</a> on page 2575
How to adding a price item in an ancillary pricing rule type	<a href="#">Adding a Price Item in an Ancillary Pricing Rule Type</a> on page 2578
How to add a price item parameter in an ancillary pricing rule type	<a href="#">Adding a Price Item Parameter in an Ancillary Pricing Rule Type</a> on page 2581
How to define the ancillary-specific data in an ancillary pricing rule type	<a href="#">Defining the Ancillary-Specific Data in an Ancillary Pricing Rule Type</a> on page 2582
How to define pricing arrangements in an ancillary pricing rule type	<a href="#">Defining Pricing Arrangements in an Ancillary Pricing Rule Type</a> on page 2584

## **Deleting an Ancillary Pricing Rule Type**

### **Procedure**

To delete an ancillary pricing rule type:

1. Click the **Admin** link in the **Application** toolbar.  
A list appears.
2. From the **Admin** menu, select **P** and then click **Pricing Rule Type**.  
A sub-menu appears.
3. Click the **Search** option from the **Pricing Rule Type** sub-menu.  
The **Pricing Rule Type** screen appears.
4. In the **Pricing Rule Type List** zone, click the **Delete** (🗑️) icon in the **Delete** column corresponding to the ancillary pricing rule type that you want to delete.  
A message appears confirming whether you want to delete the ancillary pricing rule type.

**Note:** You can delete an ancillary pricing rule type only when it is not yet used in the system.

**Tip:** Alternatively, you can delete an ancillary pricing rule type by clicking the **Delete** button in the **Pricing Rule Type** zone.

5. Click **OK**.

The ancillary pricing rule type is deleted.

### Related Topics

For more information on...	See...
<b>Pricing Rule Type</b> screen	<a href="#">Pricing Rule Type</a> on page 2343
<b>Pricing Rule Type List</b> zone	<a href="#">Pricing Rule Type List</a> on page 2344
<b>Pricing Rule Type</b> zone	<a href="#">Pricing Rule Type</a> on page 2347

## Viewing the Ancillary Pricing Rule Type Details

### Procedure

To view the details of an ancillary pricing rule type:

1. Click the **Admin** link in the **Application** toolbar.  
A list appears.
2. From the **Admin** menu, select **P** and then click **Pricing Rule Type**.  
A sub-menu appears.
3. Click the **Search** option from the **Pricing Rule Type** sub-menu.  
The **Pricing Rule Type** screen appears.
4. In the **Pricing Rule Type List** zone, click the **Broadcast**  icon corresponding to the ancillary pricing rule type whose details you want to view.  
The **Pricing Rule Type** zone appears.
5. View the details of the ancillary pricing rule type in the **Pricing Rule Type** zone.

### Related Topics

For more information on...	See...
<b>Pricing Rule Type</b> screen	<a href="#">Pricing Rule Type</a> on page 2343
<b>Pricing Rule Type List</b> zone	<a href="#">Pricing Rule Type List</a> on page 2344
<b>Pricing Rule Type</b> zone	<a href="#">Pricing Rule Type</a> on page 2347

## Defining an Ancillary Pricing Rule for a Parent Customer

### Prerequisites

To define an ancillary pricing rule for a parent customer, you should have:

- Pricing rule type where the category is set to **Ancillary**.
- Price items associated with the ancillary pricing rule type.
- Pricing arrangements defined in the ancillary pricing rule type.

### Procedure

To define an ancillary pricing rule for a parent customer:

1. Search for a parent customer in the **Customer 360° View** screen.
2. In the **Search Results** section, click the **View** () icon corresponding to the parent customer whose pricing details you want to view.

The **Person** tab appears in the **Customer 360° Information** screen.

3. Click the **Pricing** tab.

The **Pricing** tab appears.

4. Click the **Add** link in the upper right corner of the **Parent Customer Pricing Rules** zone.

The **Pricing Rule** screen appears. It contains the following fields:

Field Name	Field Description	Mandatory (Yes or No)
Person Name	Indicates the parent customer for whom you want to create an ancillary pricing rule type.	Not applicable
Person Type	Indicates the type of the parent customer. The valid value is: <ul style="list-style-type: none"> <li>• Parent Customer</li> </ul> <div style="border: 1px solid black; padding: 2px; margin-top: 5px;"> <b>Note:</b> If you are defining the pricing rule type for the parent customer, then the person type will be <b>Parent Customer</b>.         </div>	Not applicable
Pricing Rule Type	Used to indicate the pricing rule type using which you want to create an ancillary pricing rule.	Yes

5. Select the required pricing rule type in the respective field.
6. Click **OK**.

The **Ancillary Pricing Rule** screen appears. It contains the following sections:

- **Customer Information** – Displays the information about the parent customer. It contains the following fields:

Field Name	Field Description
Parent Customer Information	Indicates the parent customer for whom you are defining an ancillary pricing rule.
Pricing Rule Type	Indicates the pricing rule type using which you are defining an ancillary pricing rule.

- **Main** – Used to specify basic details about the ancillary pricing rule. In addition it allows you to define pricing for different types of ancillary charges. It contains the following fields:

Field Name	Field Description	Mandatory (Yes or No)
Price Item	Used to indicate the price item for which you want to define an ancillary pricing rule.	Yes
Pricing Start Date	Used to specify the date from when the ancillary pricing rule is effective. <div style="border: 1px solid black; padding: 2px; margin-top: 5px;"> <b>Note:</b> The pricing start date cannot be later than the pricing end date.         </div>	Yes



Field Name	Field Description	Mandatory (Yes or No)
Pricing End Date	Used to specify the date till when the ancillary pricing rule is effective.  <b>Note:</b> The pricing end date cannot be earlier than the pricing start date.	No
Rate Option	Used to indicate the rate option that you want to use while defining pricing for the price item.	Yes
Pass Through without Markup or Markdown	Used when markup or markdown should not be calculated for the ancillary charge.  <b>Note:</b> This field is enabled when the <b>Rate Option</b> field is selected.	Yes (Conditional)  <b>Note:</b> This field is required when you want to calculate the ancillary pricing without the pass through charge while defining the ancillary pricing rule.

The following fields appear only when the **Pass Through without Markup or Markdown** option is not selected. It contains the following fields:

Field Name	Field Description	Mandatory (Yes or No)
Billable Charge Line Type	Used to indicate the billable charge line type using which you want to create the ancillary pricing rule.  <b>Note:</b> The Search  icon appears corresponding to this field. On clicking the <b>Search</b> icon, the <b>Billable Line Type Search</b> window appears.  On specifying the billable charge line type, the description of the billable charge line type appears corresponding to the <b>Billable Charge Line Type</b> field.	Yes (Conditional)  <b>Note:</b> This field is required while creating a pricing arrangement with or without rate based billable charge line type.
Billable	Used to indicate whether the ancillary charge is eligible for billing or not.	Yes (Conditional)  <b>Note:</b> This field is required while creating a pricing arrangement with or without the <b>Markup or Markdown Type</b> field and the <b>Rate Based</b> option.
Rate Based	Used to indicate whether the ancillary charge is calculated using a particular rate.	Yes (Conditional)  <b>Note:</b> This field is required while creating a pricing arrangement with the <b>Rate Based</b> option.

Field Name	Field Description	Mandatory (Yes or No)
Rate	Used to indicate the rate for calculating the ancillary charge.  <b>Note:</b> This field is enabled when the <b>Rate Based</b> option is selected.	Yes (Conditional)  <b>Note:</b> This field is required when <b>Rate Based</b> option is selected.
Pricing Strategy	Used to indicate the price calculation strategy which should be applied while defining the ancillary pricing rule. The valid values are: <ul style="list-style-type: none"> <li>• Markup</li> <li>• Markdown</li> <li>• None</li> </ul>	No
Markup or Markdown Type	Used to indicate the type of charge which should be applied while defining the ancillary pricing rule. The valid values are: <ul style="list-style-type: none"> <li>• Flat Amount</li> <li>• Percentage</li> </ul> <b>Note:</b> This field is enabled when the <b>Pricing Strategy</b> field is selected.	Yes (Conditional)  <b>Note:</b> This field is required when the <b>Pricing Strategy</b> field is selected.
Amount / Percentage	Used to specify the actual proportion of the charge that should be applied while defining the ancillary pricing rule.	Yes (Conditional)  <b>Note:</b> This field is required when the <b>Markup or Markdown Type</b> field is selected.

- **Characteristics** – Used to define the characteristics for an ancillary pricing rule.

7. Enter the required details in the **Main** section.
8. Define the characteristics for an ancillary pricing rule, if required.
9. Click **Save**.

The ancillary pricing rule is defined for a parent customer.

### **Related Topics**

For more information on...	See...
How to search for a parent customer	<a href="#">Searching for a Person</a> on page 185
<b>Parent Customer Pricing Rules</b> zone	<a href="#">Parent Customer Pricing Rules</a> on page 231
How to define a characteristic for an ancillary pricing rule	<a href="#">Defining Characteristics for an Ancillary Pricing Rule</a> on page 2594

## **Defining Characteristics for an Ancillary Pricing Rule**

### **Prerequisites**

To define characteristics for an ancillary pricing rule, you should have:

- Characteristic types defined in the application (where the characteristic entity is set to **Pricing Rule**).

### Procedure

To define characteristics for an ancillary pricing rule:

1. Ensure that the **Characteristics** section is expanded when you are defining or editing an ancillary pricing rule.

The **Characteristics** section contains the following fields:

Column Name	Column Description	Mandatory (Yes or No)
Effective Date	Used to specify the date from when the characteristic is effective for the ancillary pricing rule.	Yes (Conditional) <b>Note:</b> This field is required when you are defining a characteristic for the ancillary pricing rule.
Characteristic Type	Used to indicate the characteristic type. <b>Note:</b> The list includes only those characteristic types where the characteristic entity is set to <b>Pricing Rule</b> .	Yes (Conditional) <b>Note:</b> This field is required when you are defining a characteristic for the ancillary pricing rule.
Characteristic Value	Used to specify the value for the characteristic type. <b>Note:</b> If you select a predefined characteristic type, the <b>Search</b>  icon appears corresponding to the <b>Characteristic Value</b> field. On clicking the <b>Search</b> icon, the <b>Predefined Characteristic Search</b> window appears. On specifying the value for a predefined characteristic type, the description of the characteristic value appears corresponding to the <b>Characteristic Value</b> field.	Yes (Conditional) <b>Note:</b> This field is required when you are defining a characteristic for the ancillary pricing rule.

2. Enter the required details in the **Characteristics** section.
3. If you want to define more than one characteristic for the ancillary pricing rule, click the **Add**  icon and then repeat step 2.

**Note:** However, if you want to remove a characteristic from the ancillary pricing rule, click the **Delete**  icon corresponding to the characteristic.

4. Click **Save**.

The characteristics are defined for an ancillary pricing rule.

### Related Topics

For more information on...	See...
How to define an ancillary pricing rule for a parent customer	<a href="#">Defining an Ancillary Pricing Rule for a Parent Customer</a> on page 2591
How to edit an ancillary pricing rule for a parent customer	<a href="#">Editing an Ancillary Pricing Rule of a Parent Customer</a> on page 2596

For more information on...	See...
How to define an ancillary pricing rule for a bill group	<a href="#">Defining an Ancillary Pricing Rule for a Bill Group</a> on page 2599
How to edit an ancillary pricing rule for a bill group	<a href="#">Editing an Ancillary Pricing Rule of a Bill Group</a> on page 2604

## Editing an Ancillary Pricing Rule of a Parent Customer



### Prerequisites

To edit an ancillary pricing rule of a parent customer, you should have:

- Business Object **C1-PricingRuleAncillary** defined for ancillary pricing rule.

### Procedure

To edit a ancillary pricing rule of a parent customer:

1. Search for a parent customer in the **Customer 360° View** screen.
2. In the **Search Results** section, click the **View** () icon corresponding to the parent customer whose pricing details you want to view.  
The **Person** tab appears in the **Customer 360° Information** screen.
3. Click the **Pricing** tab.  
The **Pricing** screen appears.
4. In the **Parent Customer Pricing Rules** zone, click the **Edit** () icon in the **Parent Customer Pricing Rules** zone, corresponding to the ancillary pricing rule whose details you want to edit.

The **Ancillary Pricing Rule** screen appears. It contains the following sections:

- **Customer Information** – Displays the customer information.

Field Name	Field Description
Parent Customer Information	Displays the parent customer for whom the ancillary pricing rule is created.
Pricing Rule Type	Indicates the pricing rule type for whom the ancillary pricing rule is created.

- **Main** – Used to specify basic details about the ancillary pricing rule. In addition it allows you to define pricing for different types of ancillary charges. It contains the following fields:

Field Name	Field Description	Mandatory (Yes or No)
Price Item	Displays the price item that is used to create ancillary pricing rule.	Not applicable
Pricing Start Date	Displays the date from when the ancillary pricing rule is effective.	Not applicable
Pricing End Date	Used to specify the date till when the ancillary pricing rule is effective.	Not applicable
Rate Option	Displays the rate option that you want to use while defining the price item.	Not applicable

Field Name	Field Description	Mandatory (Yes or No)
Pass Through without Markup or Markdown	<p>Indicates that markup or markdown should not be calculated for the ancillary charge.</p> <p><b>Note:</b> This field is enabled when the <b>Rate Option</b> field is selected.</p>	<p>Yes (Conditional)</p> <p><b>Note:</b> This field is required when you want to calculate the ancillary pricing without the pass through charge while defining the ancillary pricing rule.</p>

The following fields appear only when the **Pass Through without Markup or Markdown** option is not selected. It contains the following fields:

Field Name	Field Description	Mandatory (Yes or No)
Billable Charge Line Type	<p>Used to indicate the billable charge line type using which you want to create the ancillary pricing rule.</p> <p><b>Note:</b></p> <p>The Search  icon appears corresponding to this field. On clicking the <b>Search</b> icon, the <b>Billable Line Type Search</b> window appears.</p> <p>On specifying the billable charge line type, the description of the billable charge line type appears corresponding to the <b>Billable Charge Line Type</b> field.</p>	<p>Yes (Conditional)</p> <p><b>Note:</b> This field is required while creating a pricing arrangement with or without rate based billable charge line type.</p>
Billable	<p>Used to indicate whether the ancillary charge is eligible for billing or not.</p>	<p>Yes (Conditional)</p> <p><b>Note:</b> This field is required while creating a pricing arrangement with or without the <b>Rate Based</b> option.</p>
Rate Based	<p>Used to indicate whether the ancillary charge is calculated using a particular rate.</p>	<p>Yes (Conditional)</p> <p><b>Note:</b> This field is required while creating a pricing arrangement with the <b>Rate Based</b> option.</p>
Rate	<p>Used to indicate the rate for calculating the ancillary charge.</p> <p><b>Note:</b> This field is enabled when the <b>Rate Based</b> option is selected.</p>	<p>Yes (Conditional)</p> <p><b>Note:</b> This field is required when <b>Rate Based</b> option is selected.</p>

Field Name	Field Description	Mandatory (Yes or No)
Pricing Strategy	Used to indicate the price calculation strategy which should be applied while defining the ancillary pricing rule. The valid values are: <ul style="list-style-type: none"> <li>• Markup</li> <li>• Markdown</li> <li>• None</li> </ul>	No
Markup or Markdown Type	Used to indicate the type of charge which should be applied while defining the ancillary pricing rule. The valid values are: <ul style="list-style-type: none"> <li>• Flat Amount</li> <li>• Percentage</li> </ul> <p><b>Note:</b> This field is enabled when the <b>Pricing Strategy</b> field is selected.</p>	Yes (Conditional)  <b>Note:</b> This field is required when the <b>Pricing Strategy</b> field is selected.
Amount / Percentage	Used to specify the actual proportion of the charge that should be applied while defining the ancillary pricing rule.	Yes (Conditional)  <b>Note:</b> This field is required when the <b>Markup or Markdown Type</b> field is selected.

- **Characteristics** – Used to define the characteristics for the ancillary pricing rule.

5. Modify the details in the **Main** section.
6. Define, edit, or remove characteristics for an ancillary pricing rule, if required.
7. Click **Save**.

The changes made to an ancillary pricing rule for a parent customer are saved.

### **Related Topics**

For more information on...	See...
How to search for a parent customer	<a href="#">Searching for a Person</a> on page 185
<b>Parent Customer Pricing Rules</b> zone	<a href="#">Parent Customer Pricing Rules</a> on page 231
How to define the characteristics for an ancillary pricing rule	<a href="#">Defining Characteristics for an Ancillary Pricing Rule</a> on page 2594

## **Deleting an Ancillary Pricing Rule of a Parent Customer**

### **Procedure**

To delete an ancillary pricing rule of a parent customer:

1. Search for a parent customer in the **Customer 360° View** screen.
2. In the **Search Results** section, click the **View** () icon corresponding to the parent customer whose pricing details you want to view.

The **Person** tab appears in the **Customer 360° Information** screen.

- Click the **Pricing** tab.

The **Pricing** screen appears.

- In the **Parent Customer Pricing Rules** zone, click the **Delete** () icon in the **Delete** column corresponding to the ancillary pricing rule that you want to delete.

A message appears confirming whether you want to delete the ancillary pricing rule of a parent customer.

**Note:** You can delete an ancillary pricing rule only when it is not yet used in the system.

- Click **OK**.

The ancillary pricing rule of a parent customer is deleted.

### Related Topics

For more information on...	See...
How to search for a parent customer	<a href="#">Searching for a Person</a> on page 185
<b>Parent Customer Pricing Rules</b> zone	<a href="#">Parent Customer Pricing Rules</a> on page 231

## Defining an Ancillary Pricing Rule for a Bill Group

### Prerequisites

To define an ancillary pricing rule for a bill group, you should have:

- Pricing rule type where the category is set to **Ancillary**.
- Price items associated with the ancillary pricing rule type.
- Pricing arrangements defined in the ancillary pricing rule type.

### Procedure

To define an ancillary pricing rule for a bill group:

- Search for the Administrative Services Only (ASO) person, whose person type is set to **Bill Group**, in the **Customer 360° View** screen.
- In the **Search Results** section, click the **View** () icon corresponding to the bill group whose pricing details you want to view.

The **Person** tab appears in the **Customer 360° Information** screen.

- Click the **Pricing** tab.

The **Pricing** tab appears.

- Click the **Broadcast** () icon in the **Bill Group ASO Policy Information** zone, corresponding to the **Bill Group Information** column, whose bill group details you want to view.

The **Bill Group ASO Policy Pricing Rules** zone appears.

- Click the **Add** link in the upper-right corner of the **Bill Group ASO Policy Pricing Rules** zone.

The **Pricing Rule** screen appears. It contains the following fields:

Field Name	Field Description	Mandatory (Yes or No)
Person Name	Indicates the name of the parent customer.	Not applicable

Field Name	Field Description	Mandatory (Yes or No)
Person Type	Indicates the type of the parent customer.  <b>Note:</b> If you are defining the pricing rule type for the parent customer, then the person type will be <b>Parent Customer</b> .	Not applicable
Pricing Rule Type	Used to indicate the pricing rule type using which you want to create an ancillary pricing rule.  <b>Note:</b> Select the <b>Ancillary Pricing Rule Type</b> option, as the pricing rule.	Yes  <b>Note:</b> If the pricing rule type is not selected then the application displays an error message.
Pricing Group	Used to indicate the pricing group which is used while defining the pricing.	No
Policy Status	Used to indicate the policy status for the pricing rule. The valid values are: <ul style="list-style-type: none"> <li>• In Force/Active</li> <li>• Post Runout</li> <li>• Runout</li> </ul> <b>Note:</b> An ancillary pricing rule cannot be created for <b>Runout</b> or <b>Post Runout</b> policy status where the policy run out end date is missing.	Yes

6. Click **OK**.

The **Ancillary Pricing Rule** screen appears. It contains the following sections:

- **Customer Information** – Displays the information about the bill group. It contains the following fields:

Field Name	Field Description
Bill Group Information	Displays the bill group information.
Policy Start Date	Displays the date from when the policy is effective.
Policy End Date	Displays the date till when the policy is effective.
Policy Status	Indicates the policy status for the pricing rule.
Pricing Rule Type	Indicates the pricing rule type for whom the ancillary pricing rule is created.

- **Main** – Used to specify basic details about the ancillary pricing rule. In addition it allows you to define pricing for different types of ancillary charges.

Field Name	Field Description	Mandatory (Yes or No)
Price Item	Used to indicate the price item that is used to create ancillary pricing rule.	Yes
Pricing Start Date	Used to specify the date from when the ancillary pricing rule is effective.	Yes
Pricing End Date	Used to specify the date till when the ancillary pricing rule is effective.	No



Field Name	Field Description	Mandatory (Yes or No)
Rate Option	Used to indicate the rate option that you want to use while defining the price item.	Yes
Pass Through without Markup or Markdown	Used when markup or markdown should not be calculated for the ancillary charge.  <b>Note:</b> This field is enabled when the <b>Rate Option</b> field is selected.	Yes (Conditional)  <b>Note:</b> This field is required when you want to calculate the ancillary pricing without the pass through charge while defining the ancillary pricing rule.

The following fields appear only when the **Pass Through without Markup or Markdown** option is not selected. It contains the following fields:

Field Name	Field Description	Mandatory (Yes or No)
Billable Charge Line Type	Used to indicate the billable charge line type using which you want to create the ancillary pricing rule.  <b>Note:</b> The Search (🔍) icon appears corresponding to this field. On clicking the <b>Search</b> icon, the <b>Billable Line Type Search</b> window appears.  On specifying the billable charge line type, the description of the billable charge line type appears corresponding to the <b>Billable Charge Line Type</b> field.	Yes (Conditional)  <b>Note:</b> This field is required while creating a pricing arrangement with or without rate based billable charge line type.
Billable	Used to indicate whether the ancillary charge is eligible for billing or not.	Yes (Conditional)  <b>Note:</b> This field is required while creating a pricing arrangement with or without the <b>Markup or Markdown Type</b> field and the <b>Rate Based</b> option.
Rate Based	Used to indicate whether the ancillary charge is calculated using a particular rate.	Yes (Conditional)  <b>Note:</b> This field is required while creating a pricing arrangement with the <b>Rate Based</b> option.
Rate	Used to indicate the rate for calculating the ancillary charge.  <b>Note:</b> This field is enabled when the <b>Rate Based</b> option is selected.	Yes (Conditional)  <b>Note:</b> This field is required when <b>Rate Based</b> option is selected.

Field Name	Field Description	Mandatory (Yes or No)
Pricing Strategy	Used to indicate the price calculation strategy which should be applied while defining the ancillary pricing rule. The valid values are: <ul style="list-style-type: none"> <li>• Markup</li> <li>• Markdown</li> <li>• None</li> </ul>	No
Markup or Markdown Type	Used to indicate the type of charge which should be applied while defining the ancillary pricing rule. The valid values are: <ul style="list-style-type: none"> <li>• Flat Amount</li> <li>• Percentage</li> </ul> <p><b>Note:</b> This field is enabled when the <b>Pricing Strategy</b> field is selected.</p>	Yes (Conditional) <p><b>Note:</b> This field is required when the <b>Pricing Strategy</b> field is selected.</p>
Amount / Percentage	Used to specify the actual proportion of the charge that should be applied while defining the ancillary pricing rule.	Yes (Conditional) <p><b>Note:</b> This field is required when the <b>Markup or Markdown Type</b> field is selected.</p>

- **Characteristics** – Used to define the characteristics for the ancillary pricing rule.

7. Enter the required details in the **Main** section.
8. Define the characteristics for an ancillary pricing rule, if required.
9. Click **Save**.

The ancillary pricing rule for a bill group is defined.

**Note:** A price list and price assignment is created, the price list created is assigned to the ancillary pricing rule.

### Related Topics

For more information on...	See...
<b>Customer 360° Information – Pricing</b> tab	<a href="#">Customer 360° Information - Pricing</a> on page 229
<b>Parent Customer Pricing Rules</b> zone	<a href="#">Parent Customer Pricing Rules</a> on page 231
How to define the characteristics for an ancillary pricing rule	<a href="#">Defining Characteristics for an Ancillary Pricing Rule</a> on page 2594

## Defining Characteristics for an Ancillary Pricing Rule

### Prerequisites

To define characteristics for an ancillary pricing rule, you should have:

- Characteristic types defined in the application (where the characteristic entity is set to **Pricing Rule**).

### Procedure

To define characteristics for an ancillary pricing rule:

1. Ensure that the **Characteristics** section is expanded when you are defining or editing an ancillary pricing rule.

The **Characteristics** section contains the following fields:

Column Name	Column Description	Mandatory (Yes or No)
Effective Date	Used to specify the date from when the characteristic is effective for the ancillary pricing rule.	Yes (Conditional) <b>Note:</b> This field is required when you are defining a characteristic for the ancillary pricing rule.
Characteristic Type	Used to indicate the characteristic type. <b>Note:</b> The list includes only those characteristic types where the characteristic entity is set to <b>Pricing Rule</b> .	Yes (Conditional) <b>Note:</b> This field is required when you are defining a characteristic for the ancillary pricing rule.
Characteristic Value	Used to specify the value for the characteristic type. <b>Note:</b> If you select a predefined characteristic type, the <b>Search</b>  icon appears corresponding to the <b>Characteristic Value</b> field. On clicking the <b>Search</b> icon, the <b>Predefined Characteristic Search</b> window appears. On specifying the value for a predefined characteristic type, the description of the characteristic value appears corresponding to the <b>Characteristic Value</b> field.	Yes (Conditional) <b>Note:</b> This field is required when you are defining a characteristic for the ancillary pricing rule.

2. Enter the required details in the **Characteristics** section.
3. If you want to define more than one characteristic for the ancillary pricing rule, click the **Add**  icon and then repeat step 2.

**Note:** However, if you want to remove a characteristic from the ancillary pricing rule, click the **Delete**  icon corresponding to the characteristic.

4. Click **Save**.

The characteristics are defined for an ancillary pricing rule.

### **Related Topics**

For more information on...	See...
How to define an ancillary pricing rule for a parent customer	<a href="#">Defining an Ancillary Pricing Rule for a Parent Customer</a> on page 2591
How to edit an ancillary pricing rule for a parent customer	<a href="#">Editing an Ancillary Pricing Rule of a Parent Customer</a> on page 2596
How to define an ancillary pricing rule for a bill group	<a href="#">Defining an Ancillary Pricing Rule for a Bill Group</a> on page 2599

For more information on...	See...
How to edit an ancillary pricing rule for a bill group	<a href="#">Editing an Ancillary Pricing Rule of a Bill Group</a> on page 2604

## Editing an Ancillary Pricing Rule of a Bill Group



### Prerequisites

To edit an ancillary pricing rule of a bill group, you should have:

- Business Object **C1-PricingRuleAncillary** defined for ancillary pricing rule.

### Procedure

To edit an ancillary pricing rule of a bill group:

1. Search for a bill group in the **Customer 360° View** screen.
2. In the **Search Results** section, click the **View** () icon corresponding to the bill group whose pricing details you want to view.  
The **Person** tab appears in the **Customer 360° Information** screen.
3. Click the **Pricing** tab.  
The **Pricing** tab appears.
4. Click the **Broadcast** () icon in the **Bill Group ASO Policy Information** zone, corresponding to the **Bill Group Information** column, whose bill group details you want to view.  
The **Bill Group ASO Policy Pricing Rules** zone appears.
5. Click the **Edit** () icon in the **Bill Group ASO Policy Pricing Rules** zone, corresponding to the **Pricing Group Information** column, whose pricing details you want to edit.

The **Ancillary Pricing Rule** screen appears. It contains the following sections:

- **Customer Information** – Displays the customer information for bill group.

Field Name	Field Description
Bill Group Information	Displays the bill group for whom the ancillary pricing rule is define.
Policy Start Date	Displays the date from when the policy is effective.
Policy End Date	Displays the date till when the policy is effective.
Policy Status	Indicates the policy status for the pricing rule.
Pricing Rule Type	Indicates the pricing rule type using which you want to define an ancillary pricing rule.
Status	Indicates the status of the bill group.

- **Main** – Used to specify basic details about the ancillary pricing rule. It contains the following fields:

Field Name	Field Description	Mandatory (Yes or No)
Price Item	Indicates the price item that is used to create ancillary pricing rule.	Yes
Pricing Start Date	Displays the date from when the ancillary pricing rule is effective.	Yes

Field Name	Field Description	Mandatory (Yes or No)
Pricing End Date	Used to specify the date till when the ancillary pricing rule is effective.  <b>Note:</b> This field by default displays the <b>Policy End Date</b> .	No
Rate Option	Indicates the rate option that you want to use while defining the price item.	Yes
Pass Through without Markup or Markdown	Used to indicate that markup and markdown prices must not be considered when the ancillary transaction is processed.  <b>Note:</b> This field is enabled when the <b>Rate Option</b> field is selected.	Yes (Conditional)  <b>Note:</b> This field is required when you want to calculate the ancillary pricing without the pass through charge while defining the ancillary pricing rule.

The following fields appear only when the **Pass Through without Markup or Markdown** option is not selected. It contains the following fields:

Field Name	Field Description	Mandatory (Yes or No)
Billable Charge Line Type	Used to indicate the billable charge line type using which you want to create the ancillary pricing rule.  <b>Note:</b> The Search  icon appears corresponding to this field. On clicking the <b>Search</b> icon, the <b>Billable Line Type Search</b> window appears.  On specifying the billable charge line type, the description of the billable charge line type appears corresponding to the <b>Billable Charge Line Type</b> field.	Yes (Conditional)  <b>Note:</b> This field is required while creating a pricing arrangement with or without rate based billable charge line type.
Billable	Used to indicate whether the ancillary charge is eligible for billing or not.	Yes (Conditional)  <b>Note:</b> This field is required while creating a pricing arrangement with or without the <b>Markup or Markdown Type</b> field and the <b>Rate Based</b> option.
Rate Based	Used to indicate whether the ancillary charge is calculated using a particular rate.	Yes (Conditional)  <b>Note:</b> This field is required while creating a pricing arrangement with the <b>Rate Based</b> option.

Field Name	Field Description	Mandatory (Yes or No)
Rate	Used to indicate the rate for calculating the ancillary charge.  <b>Note:</b> This field is enabled when the <b>Rate Based</b> option is selected.	Yes (Conditional)  <b>Note:</b> This field is required when <b>Rate Based</b> option is selected.
Pricing Strategy	Used to indicate the price calculation strategy which should be applied while defining the ancillary pricing rule. The valid values are: <ul style="list-style-type: none"> <li>• Markup</li> <li>• Markdown</li> <li>• None</li> </ul>	No
Markup or Markdown Type	Used to indicate the type of charge which should be applied while defining the ancillary pricing rule. The valid values are: <ul style="list-style-type: none"> <li>• Flat Amount</li> <li>• Percentage</li> </ul> <b>Note:</b> This field is enabled when the <b>Pricing Strategy</b> field is selected.	Yes (Conditional)  <b>Note:</b> This field is required when the <b>Pricing Strategy</b> field is selected.
Amount/Percentage	Used to specify the actual proportion of the charge that should be applied while defining the ancillary pricing rule.	Yes (Conditional)  <b>Note:</b> This field is required when the <b>Markup or Markdown Type</b> field is selected.

- **Characteristics** – Used to define the characteristics for the ancillary pricing rule.

6. Modify the details in the **Main** section.
7. Define, edit, or remove characteristics for an ancillary pricing rule, if required.
8. Click **Save**.

The changes made to an ancillary pricing rule for a bill group are saved.



### **Related Topics**

For more information on...	See...
How to search for a parent customer	<a href="#">Searching for a Person</a> on page 185
<b>Parent Customer Pricing Rules</b> zone	<a href="#">Parent Customer Pricing Rules</a> on page 231
How to define characteristics for an ancillary pricing rule	<a href="#">Defining Characteristics for an Ancillary Pricing Rule</a> on page 2594

## **Deleting an Ancillary Pricing Rule of a Bill Group**

### **Procedure**

To delete an ancillary pricing rule of a bill group:

1. Search for a bill group in the **Customer 360° View** screen.
2. In the **Search Results** section, click the **View** () icon corresponding to the bill group whose pricing details you want to view.  
The **Person** tab appears in the **Customer 360° Information** screen.
3. Click the **Pricing** tab.  
The **Pricing** tab appears.
4. Click the **Broadcast** () icon in the **Bill Group ASO Policy Information** zone, corresponding to the **Bill Group Information** column, whose bill group details you want to delete.  
The **Bill Group ASO Policy Pricing Rules** zone appears.
5. Click the **Delete** () icon in the **Delete** column corresponding to the **Pricing Group Information** column, whose bill group information you want to delete.  
A message appears confirming whether you want to delete the ancillary pricing rule of a bill group.

**Note:** You can delete an ancillary pricing rule only when it is not yet used in the system.

6. Click **OK**.  
The ancillary pricing rule of a bill group is deleted.

### Related Topics

For more information on...	See...
How to search for a parent customer	<a href="#">Searching for a Person</a> on page 185
<b>Parent Customer Pricing Rules</b> zone	<a href="#">Parent Customer Pricing Rules</a> on page 231

## Discount Pricing

The Administrative Services Only (ASO) provider may offer some discounts to its network hospitals and providers. A portion of these discounts is then charged to the self-funded employer. Oracle Revenue Management and Billing enables you to calculate and bill the discount share or discount guarantee amount to the self-funded employer. The system enables you to calculate the discount using the following methods:

- [Discount Share](#) on page 2608
- [Discount Guarantee](#) on page 2608

The pricing for the share or guarantee discount can be defined using the respective discount pricing rules. You can define a share or guarantee discount pricing rule only at the parent customer level. You can define the share or guarantee discount pricing rules for parent customers from the **Customer 360° Information** screen. You can define a share or guarantee discount pricing rule using a discount arrangement pricing rule type.

Once a discount arrangement pricing rule type is defined, you can create discount pricing rules using the discount arrangement pricing rule type. Once a discount pricing rule is created, the system creates multiple price assignments in a price list and assigns the price list to the parent customer.

The following new batches are introduced in this release:

- **C1-ACDA** – Once the transaction legs and calculation lines are created for discount, this batch is used to accumulate the discount. It also calculates the required minimum or maximum limit on the contract. For more information about the batch refer to *Oracle Revenue Management and Billing Batch Guide*.

- **C1-BCDA** – Once the discount is accumulated, this batch is used to create the credit (if any) and discount billable charges. It is also used to calculate the bill after date. For more information about the batch refer to *Oracle Revenue Management and Billing Batch Guide*.

## Types of Discount Arrangement

The Oracle Revenue Management and Billing enables you to calculate the discount using the following methods:

- [Discount Share](#) on page 2608
- [Discount Guarantee](#) on page 2608

### Discount Share

In the discount share method, the discount is calculated while processing the claim transaction. It is calculated as follows:

**Billable Discount Amount = Discount Savings Amount \* Discount Percentage**

Note that the discount share percentage varies depending on various parameters (such as health coverage class, In or Out Network, etc). Therefore, the system enables you to define different discount percentage for the claim transactions which are received from employees with different set of attributes. The system allows you to define maximum discount amount that can be charged per claim transaction. You can optionally configure the minimum and maximum discount limit on the contract. Note that the minimum limit is applicable during the settlement and maximum limit is applicable when you execute the **C1-ACDA** batch. The minimum and maximum limit can be a flat limit or enrollment based limit. Once the discount is accumulated, you can charge the customer at the pre-defined frequency. If the discount amount exceeds the maximum discount limit per claim or if the discount amount exceeds maximum discount limit defined on the contract, a credit billable charge is created for the customer.

### Discount Guarantee

In the discount guarantee method, the discount is calculated while processing the claim transaction. It is calculated as follows:

**Targeted Guaranteed Amount = Covered Charge Amount \* Discount Guarantee Percentage**

**Billable Discount Amount = Discount Savings Amount - Targeted Guaranteed Amount**

Note that the discount guarantee percentage varies depending on various parameters (such as health coverage class, In or Out Network, etc). Therefore, the system enables you to define different discount percentage for the claim transactions which are received from employees with different set of attributes. The system allows you to define maximum discount amount that can be charged per claim transaction. You can optionally configure the minimum and maximum discount limit on the contract. Note that the minimum limit is applicable during the settlement and maximum limit is applicable when you execute the **C1-ACDA** batch. The minimum and maximum limit can be a flat limit or enrollment based limit. Once the discount is accumulated, you can charge the customer at the pre-defined frequency. If the discount amount exceeds the maximum discount limit per claim or if the discount amount exceeds maximum discount limit defined on the contract, a credit billable charge is created for the customer.

## Defining a Discount Arrangement Pricing Rule Type

### Prerequisites

To define a discount arrangement pricing rule type, you should have:

- Discount Arrangement pricing rule type business object defined in the application
- Discount Arrangement pricing rule business object defined in the application

### Procedure

To define a discount arrangement pricing rule type:

1. Click the **Admin** link in the **Application** toolbar.

A list appears.



- From the **Admin** menu, select **P** and then click **Pricing Rule Type**.

A sub-menu appears.

- Click the **Add** option from the **Pricing Rule Type** sub-menu.

The **Select Business Object** screen appears. It contains the following field:

Field Name	Field Description	Mandatory (Yes or No)
Pricing Rule Type Business Object	<p>Used to indicate the business object using which you want to create a discount arrangement pricing rule type. The valid values are:</p> <ul style="list-style-type: none"> <li>Aggregate Stop-Loss (ASL) Pricing Rule Type</li> <li>Ancillary Pricing Rule Type</li> <li>Claim Pricing Rule Type</li> <li>Discount Arrangement Pricing Rule Type</li> <li>Flat Fee Pricing Rule Type</li> <li>Level Funded (LF) Pricing Rule Type</li> <li>Retention Type Claim Based Pricing Rule Type</li> <li>Retention Type Enrollment Based Pricing Rule Type</li> <li>Specific Stop-Loss (SSL) Pricing Rule Type</li> </ul> <p><b>Note:</b> You must select the <b>Discount Arrangement Pricing Rule Type</b> option from the <b>Pricing Rule Type Business Object</b> list while defining a discount arrangement pricing rule type.</p>	Yes

**Tip:** Alternatively, you can access this screen by clicking the **Add** button in the **Page Title** area of the **Pricing Rule Type** screen.

- Select the **Discount Arrangement Pricing Rule Type** option from the **Pricing Rule Type Business Object** list.
- Click **OK**.

The **Discount Arrangement Pricing Rule Type** screen appears. It contains the following sections:

- Main** – Used to specify basic details about the discount arrangement pricing rule type.
- Algorithms** – Used to associate the algorithms with the discount arrangement pricing rule type.
- Additional Data** – Used to specify additional information in the discount arrangement pricing rule type.
- Price Items** – Used to add the price items for which you can define the discount arrangement pricing rules using the discount arrangement pricing rule type.
- Price Item Parameters** – Used to add the price item parameters based on which you want to define the price item pricing.
- Characteristics** – Used to define characteristics for the discount arrangement pricing rule type.
- DA – Specific Additional Data** – Used to specify discount arrangement-specific additional data in the discount arrangement pricing rule type.

The **Main** section contains the following fields:

Field Name	Field Description	Mandatory (Yes or No)
Pricing Rule Type	Used to specify the discount arrangement pricing rule type.	Yes
Description	Used to specify the description for the discount arrangement pricing rule type.	Yes
Detailed Description	Used to specify additional information about the discount arrangement pricing rule type.	No
Pricing Rule Business Object	<p>Used to indicate the business object using which you want to create the discount arrangement pricing rule. The valid value are:</p> <ul style="list-style-type: none"> <li>• <b>Aggregate Stop-Loss (ASL) Pricing Rule</b></li> <li>• <b>Ancillary Pricing Rule</b></li> <li>• <b>Claim Pricing Rule</b></li> <li>• <b>Discount Arrangement Pricing Rule</b></li> <li>• <b>Flat Fee Pricing Rule</b></li> <li>• <b>Level Funded (LF) Pricing Rule</b></li> <li>• <b>Retention Type Claim Based Pricing Rule</b></li> <li>• <b>Retention Type Enrollment Based Pricing Rule</b></li> <li>• <b>Specific Stop-Loss (SSL) Pricing Rule</b></li> </ul> <p><b>Note:</b> You must select the <b>Discount Arrangement Pricing Rule</b> option from the <b>Pricing Rule Business Object</b> list while defining a discount arrangement pricing rule type.</p>	Yes
Business Object	Indicates the business object using which you are defining the discount arrangement pricing rule type.	Not applicable
Status	<p>Used to indicate the status of the discount arrangement pricing rule type. The valid values are:</p> <ul style="list-style-type: none"> <li>• Active</li> <li>• Inactive</li> </ul>	Yes
Primary	<p>Used to indicate whether the discount arrangement pricing rule type is a primary pricing rule type.</p> <p><b>Note:</b> You must not select the <b>Primary</b> option while defining a discount arrangement pricing rule type.</p>	Not applicable

Field Name	Field Description	Mandatory (Yes or No)
Pricing Rule Type Category	<p>Used to indicate the category to which the discount arrangement pricing rule type belongs. The valid value is:</p> <ul style="list-style-type: none"> <li>• <b>Aggregate Stop-Loss</b></li> <li>• <b>Ancillary</b></li> <li>• <b>Claim</b></li> <li>• <b>Discount Arrangement</b></li> <li>• <b>Flat Fees</b></li> <li>• <b>Level Funded</b></li> <li>• <b>Retention Type Claim Based</b></li> <li>• <b>Retention Type Enrollment Based</b></li> <li>• <b>Specific Stop-Loss</b></li> </ul> <p><b>Note:</b> You must select the <b>Discount Arrangement</b> option from the <b>Pricing Rule Type Category</b> list while defining a discount arrangement pricing rule type.</p>	Yes

6. Enter the required details in the **Main** section.
7. Select the **Discount Arrangement Pricing Rule** option from the **Pricing Rule Business Object** list.
8. Ensure that **Primary** option is not selected when you are defining a discount arrangement pricing rule type.
9. Select the **Discount Arrangement** option from the **Pricing Rule Type Category** list.
10. Associate the following algorithms with the discount arrangement pricing rule type:

System Event	Algorithm	Algorithm Type	Description
Account and Price Item Derivation	C1_ACCPRDIS	C1_ACCPRDIS	Account and Priceitem Derivation For Discount Arrangement

11. Define additional data for a discount arrangement pricing rule type, if required.
12. Add the required price items in the discount arrangement pricing rule type.
13. Add the price item parameters in the discount arrangement pricing rule type, if required.
14. Define characteristics for a discount arrangement pricing rule type, if required.
15. Add discount arrangement-specific additional data in the discount arrangement pricing rule type.
16. Click **Save**.

The discount arrangement pricing rule type is defined.

### **Related Topics**

For more information on...	See...
<b>Pricing Rule Type</b> screen	<a href="#">Pricing Rule Type</a> on page 2343
How to associate algorithms with the discount arrangement pricing rule type	<a href="#">Associating Algorithms with a Discount Arrangement Pricing Rule Type</a> on page 2612

For more information on...	See...
How to define additional data for a discount arrangement pricing rule type	<a href="#">Defining Additional Data in a Discount Arrangement Pricing Rule Type</a> on page 2615
How to add price items in the discount arrangement pricing rule type	<a href="#">Adding a Price Item in a Discount Arrangement Pricing Rule Type</a> on page 2617
How to add price item parameters in the discount arrangement pricing rule type	<a href="#">Adding a Price Item Parameter in a Discount Arrangement Pricing Rule Type</a> on page 2620
How to define characteristics for a discount arrangement pricing rule type	<a href="#">Defining a Characteristic for a Discount Arrangement Pricing Rule Type</a> on page 2621
How to add discount arrangement-specific data in the discount arrangement pricing rule type	<a href="#">Defining the Discount Specific Data in a Discount Arrangement Pricing Rule Type</a> on page 2622

## Associating Algorithms with a Discount Arrangement Pricing Rule Type

### Prerequisites

To associate algorithms with a discount arrangement pricing rule type, you should have:

- An algorithm defined using the **C1\_ACCPRIDIS** algorithm type.

### Procedure

To associate algorithms with a discount arrangement pricing rule type:

1. Ensure that the **Algorithms** section is expanded when you are defining or editing a *discount arrangement pricing rule type*.

The **Algorithms** section contains the following fields in a grid:

Field Name	Field Description	Mandatory (Yes or No)
System Event	<p>Used to indicate the system event when you want to execute the algorithm. The valid values are:</p> <ul style="list-style-type: none"> <li>• <b>Account and Price Item Derivation</b> - Used to derive the account and price item for the discount arrangement transaction.</li> <li>• <b>Accumulation Billable Charge Post Proc</b> - Used to introduce a custom logic after creating discount share or discount guarantee billable charges. This algorithm is invoked in the <b>C1-BCDA (Create Billable Charge for Discount)</b> batch.</li> <li>• <b>Accumulation Billable Charge Pre Proc</b> - Used to introduce a custom logic before creating discount share or discount guarantee billable charges. This algorithm is invoked in the <b>C1-BCDA (Create Billable Charge for Discount)</b> batch.</li> <li>• <b>Accumulation Post Processing</b> - Used to introduce a custom logic after accumulating the discount share or discount guarantee amount. This algorithm is invoked in the <b>C1-ACDA (Accumulate Discount Arrangement)</b> batch.</li> <li>• <b>Accumulation Pre Processing</b> - Used to introduce a custom logic before accumulating the discount share or discount guarantee amount. This algorithm is invoked in the <b>C1-ACDA (Accumulate Discount Arrangement)</b> batch.</li> <li>• <b>Pricing Rule Post Processing</b> - Used to introduce a custom logic once the effective discount arrangement pricing rule is derived for the discount arrangement transaction.</li> <li>• <b>Transaction Validation</b> - Used to introduce a custom validation for the discount arrangement transaction.</li> </ul>	<p>Yes (Conditional)</p> <div style="border: 1px solid black; padding: 5px; margin-top: 10px;"> <p><b>Note:</b> This field is required when you are associating an algorithm with the discount arrangement pricing rule type.</p> </div>
Sequence	<p>Used to specify the order in which the algorithms with the same system event must be executed.</p>	<p>Yes (Conditional)</p> <div style="border: 1px solid black; padding: 5px; margin-top: 10px;"> <p><b>Note:</b> This field is required when you are associating an algorithm with the discount arrangement pricing rule type.</p> </div>

Field Name	Field Description	Mandatory (Yes or No)
Algorithm	<p>Used to specify the algorithm that you want to execute on the system event.</p> <p><b>Note:</b></p> <p>Once you select the system event, the <b>Search</b> (🔍) icon appears corresponding to the <b>Algorithm</b> field. On clicking the <b>Search</b> (🔍) icon, the <b>Algorithm Search</b> window appears.</p> <p>On specifying the algorithm, the description of the algorithm appears corresponding to the <b>Algorithm</b> field.</p>	<p>Yes (Conditional)</p> <p><b>Note:</b> This field is required when you are associating an algorithm with the discount arrangement pricing rule type.</p>

2. Enter the following details in the **Algorithms** section:

System Event	Algorithm	Mandatory (Yes or No)	For more information, see...
Account and Price Item Derivation	C1_ACCPRIDIS	Yes	Information will be available soon...
Accumulation Billable Charge Post Proc	-	No	-
	<p><b>Note:</b> An accumulation billable charge post processing algorithm type is not shipped with the product. You can create a custom algorithm type, if required.</p>		
Accumulation Billable Charge Pre Proc	-	No	-
	<p><b>Note:</b> An accumulation billable charge pre processing algorithm type is not shipped with the product. You can create a custom algorithm type, if required.</p>		
Accumulation Post Processing	-	No	-
	<p><b>Note:</b> An accumulation post processing algorithm type is not shipped with the product. You can create a custom algorithm type, if required.</p>		
Accumulation Pre Processing	-	No	-
	<p><b>Note:</b> A accumulation pre processing algorithm type is not shipped with the product. You can create a custom algorithm type, if required.</p>		

System Event	Algorithm	Mandatory (Yes or No)	For more information, see...
Pricing Rule Post Processing	- <b>Note:</b> A pricing rule post processing algorithm type is not shipped with the product. You can create a custom algorithm type, if required.	No	-
Transaction Validation	- <b>Note:</b> An algorithm type for validating a discount arrangement transaction is not shipped with the product. You can create a custom algorithm type, if required.	No	-

- If you want to associate more than one algorithm with the discount arrangement pricing rule type, click the **Add** (+) icon and then specify the details. However, if you want to remove an algorithm from the discount arrangement pricing rule type, click the **Delete** (🗑️) icon corresponding to the algorithm.
- Click **Save**.

The algorithms are associated with the discount arrangement pricing rule type.

### Related Topics

For more information on...	See...
How to define the discount arrangement pricing rule type	<a href="#">Defining a Discount Arrangement Pricing Rule Type</a> on page 2608
How to edit the discount arrangement pricing rule type	<a href="#">Editing a Discount Arrangement Pricing Rule Type</a> on page 2625

## Defining Additional Data in a Discount Arrangement Pricing Rule Type

### Procedure

To define additional data in a discount arrangement pricing rule type:

- Ensure that the **Additional Data** section is expanded when you are defining or editing a discount arrangement pricing rule type.

The **Additional Data** section contains the following fields:

Field Name	Field Description	Mandatory (Yes or No)
Eligible for Specific Stop-Loss	Used to indicate whether price items included in the discount arrangement pricing rule type are eligible for specific stop-loss. The valid values are: <ul style="list-style-type: none"> <li>• Yes</li> <li>• No</li> </ul>	No

Field Name	Field Description	Mandatory (Yes or No)
Eligible for Level Funding	Used to indicate whether price items included in the discount arrangement pricing rule type are eligible for level funding. The valid values are: <ul style="list-style-type: none"> <li>• Yes</li> <li>• No</li> </ul> <div style="border: 1px solid black; padding: 2px;"><b>Note:</b> If you do not specify the value for this field, by default, it is set to <b>No</b>.</div>	No
Run-in Identifier Value	Used to specify the identifier value to determine whether the discount arrangement transaction is received during the run-in period of the policy.	No
Third Party Identifier Value	Used to specify the identifier value to determine whether the discount arrangement transaction is received from an external source system. <div style="border: 1px solid black; padding: 2px;"><b>Note:</b> At present, this field is not used in the system.</div>	Not applicable
Accumulation Only Identifier Value	Used to specify the identifier value to determine whether the discount arrangement transaction contains the accumulated information of ASL, SSL, and Level Funding pricing types.	No
Eligible for Write-Off in Post Runout	Used to indicate whether the discount charges should be written off when the bill is generated in the post runout period of the policy. The valid values are: <ul style="list-style-type: none"> <li>• Yes</li> <li>• No</li> </ul> For more information, refer to the <a href="#">Write-Off Charges during Post Runout</a> section. <div style="border: 1px solid black; padding: 2px;"><b>Note:</b> By default, the value is set to <b>No</b>.</div>	No
Post Runout Write-Off Adjustment Type	Used to specify the adjustment type using which you want to create post runout write-off adjustment. <div style="border: 1px solid black; padding: 2px;"><b>Note:</b> This field appears when the <b>Eligible for Write-Off in Post Runout</b> field is set to <b>Yes</b>. The <b>Search</b>  icon appears corresponding to the <b>Post Runout Write-Off Adjustment Type</b> field. On clicking the <b>Search</b> icon, the <b>Adjustment Type Search</b> window appears. On specifying the adjustment type, the description of the adjustment type appears corresponding to the <b>Post Runout Write-Off Adjustment Type</b> field.</div>	Yes (Conditional) <div style="border: 1px solid black; padding: 2px;"><b>Note:</b> This field is required when the <b>Eligible for Write-Off in Post Runout</b> field is set to <b>Yes</b>.</div>



Field Name	Field Description	Mandatory (Yes or No)
Rule Based Price Item Eligibility Field	<p>Used to indicate the transaction field which you want to use in the rules as the output parameter to determine whether the price item should be considered for billing.</p> <p><b>Note:</b> For more information, refer to the <a href="#">Price Item Eligibility</a> on page 2726 section.</p> <p>The <b>Search</b>  icon appears corresponding to the <b>Rule Based Price Item Eligibility Field</b> field. On clicking the <b>Search</b> icon, the <b>Field Search</b> window appears.</p> <p>On specifying the field name, the description of the field name appears corresponding to the <b>Rule Based Price Item Eligibility Field</b>.</p>	No
Rule Based Eligibility Value	<p>Used to specify the value which the output parameter in the rule should return when the price item in the discount arrangement pricing rule type should be considered for processing.</p>	Yes (Conditional) <p><b>Note:</b> This field is required when a value is specified in the <b>Rule Based Price Item Eligibility Field</b> field.</p>

- Enter the required details in the **Additional Data** section.
- Click **Save**.

The additional data is defined in the discount arrangement pricing rule type.

### Related Topics

For more information on...	See...
How to define a discount arrangement pricing rule type	<a href="#">Defining a Discount Arrangement Pricing Rule Type</a> on page 2608
How to edit a discount arrangement pricing rule type	<a href="#">Editing a Discount Arrangement Pricing Rule Type</a> on page 2625

## Adding a Price Item in a Discount Arrangement Pricing Rule Type

### Prerequisites

To add a price item in a discount arrangement pricing rule type, you should have:





- Price item defined in the application
- Rate options defined in the **Rate Option (C1-ExtLookRetTypeRateOpt)** extendable lookup
- Values defined for the **Invoice Type (C1INVTYP)** characteristic type
- The **C1INVTYP** characteristic type set in the **Invoice Type Characteristic Type** option type of the **C1-ASOBLNG** feature configuration
- Rule types defined in the application (where the rule type usage is set to **Price Item Eligibility**)





### Procedure

To add a price item in a pricing rule type:

1. Ensure that the **Price Items** section is expanded when you are defining or editing a discount arrangement pricing rule type.

The **Price Items** section contains the following fields in a grid:

Field Name	Field Description	Mandatory (Yes or No)						
Price Item	<p>Used to indicate the price item that you want to include in the discount arrangement pricing rule type.</p> <p><b>Note:</b></p> <p>The <b>Search</b> () icon appears corresponding to the <b>Price Item</b> field. On clicking the <b>Search</b> icon, the <b>Price Item Search</b> window appears. On specifying the price item, the description of the price item appears corresponding to the <b>Price Item</b> field.</p>	<p>Yes (Conditional)</p> <p><b>Note:</b> This field is required when you are adding a rate option and bill to account in the discount arrangement pricing rule type.</p>						
Rate Option	<p>Used to indicate one or more rate options which are valid for a price item.</p> <p>On clicking the <b>Add</b> () icon, the following field appears in a grid:</p> <table border="1"> <thead> <tr> <th>Field Name</th> <th>Field Description</th> <th>Mandatory (Yes or No)</th> </tr> </thead> <tbody> <tr> <td>Rate Option</td> <td>Used to indicate the rate option that you want to use while defining pricing for the price item.</td> <td>Yes</td> </tr> </tbody> </table> <p><b>Note:</b></p> <p>If you want to define more than one rate option to the price item in the discount arrangement pricing rule type, click the <b>Add</b> () icon. However, if you want to remove a price item from a discount arrangement pricing rule type, click the <b>Delete</b> () icon corresponding to the <b>Rate Option</b> field.</p>	Field Name	Field Description	Mandatory (Yes or No)	Rate Option	Used to indicate the rate option that you want to use while defining pricing for the price item.	Yes	Not applicable
Field Name	Field Description	Mandatory (Yes or No)						
Rate Option	Used to indicate the rate option that you want to use while defining pricing for the price item.	Yes						

Field Name	Field Description	Mandatory (Yes or No)									
Bill To Account	<p>Used to indicate a order in which the account should be considered while deriving a transaction leg.</p> <p>On clicking the <b>Add</b> () icon, the following fields appear in a grid:</p> <table border="1"> <thead> <tr> <th>Field Name</th> <th>Field Description</th> <th>Mandatory (Yes or No)</th> </tr> </thead> <tbody> <tr> <td>Priority</td> <td>Used to specify the order in which the invoice type is considered for a price item.</td> <td>Yes</td> </tr> <tr> <td>Invoice Type</td> <td>Used to indicate the type which is considered for billing. For more information, refer to the <a href="#">Bill Group's Account</a> on page 55 section.</td> <td>Yes</td> </tr> </tbody> </table> <p><b>Note:</b> The <b>Search</b> () icon appears corresponding to the <b>Invoice Type</b> field. On clicking the <b>Search</b> icon, the <b>Invoice Type Search</b> window appears.</p> <p><b>Note:</b> If you want to define more than one invoice type to the price item in a discount arrangement pricing rule type, click the <b>Add</b> () icon. However, if you want to remove a invoice type from the price item in a discount arrangement pricing rule type, click the <b>Delete</b> () icon corresponding to the <b>Priority</b> field.</p>	Field Name	Field Description	Mandatory (Yes or No)	Priority	Used to specify the order in which the invoice type is considered for a price item.	Yes	Invoice Type	Used to indicate the type which is considered for billing. For more information, refer to the <a href="#">Bill Group's Account</a> on page 55 section.	Yes	Not applicable
Field Name	Field Description	Mandatory (Yes or No)									
Priority	Used to specify the order in which the invoice type is considered for a price item.	Yes									
Invoice Type	Used to indicate the type which is considered for billing. For more information, refer to the <a href="#">Bill Group's Account</a> on page 55 section.	Yes									
Eligibility Rule Type	Used to indicate the rule type which indicates the rules that should be executed to determine whether the price item is eligible for billing.	No									

- Enter the required details in the **Price Items** section.
- If you want to define more than one price item in a discount arrangement pricing rule type, click the **Add** () icon and then repeat step 2.

**Note:** However, if you want to remove a price item from a discount arrangement pricing rule type, click the **Delete** () icon corresponding to the **Price Item** field.

- Click **Save**.

The price items are added for a discount arrangement pricing rule type.

### Related Topics

For more information on...	See...
How to define a discount arrangement pricing rule type	<a href="#">Defining a Discount Arrangement Pricing Rule Type</a> on page 2608
How to edit a discount arrangement pricing rule type	<a href="#">Editing a Discount Arrangement Pricing Rule Type</a> on page 2625

## Adding a Price Item Parameter in a Discount Arrangement Pricing Rule Type

### Prerequisites

To add a price item parameter in a discount arrangement pricing rule type, you should have:





- Parameter defined in the application where parameter usage is set to **Price Item**.
- Parameter associated with the price item.
- Transaction fields defined in the application.

### Procedure

To add a price item parameter in a discount arrangement pricing rule type:

1. Ensure that the **Price Item Parameters** section is expanded when you are defining or editing a discount arrangement pricing rule type.

The **Price Item Parameters** section contains the following fields in a grid:

Field Name	Field Description	Mandatory (Yes or No)
Price Item Parameter	<p>Used to specify the parameter which you can use while defining a discount arrangement pricing for the price item.</p> <p><b>Note:</b></p> <p>The <b>Search</b>  icon appears corresponding to the <b>Price Item Parameter</b> field. On clicking the <b>Search</b>  icon corresponding to the <b>Price Item Parameter</b> field, the <b>Parameter Search</b> window appears.</p> <p>On specifying the parameter, the description of the price item parameter appears corresponding to the <b>Price Item Parameter</b> field.</p>	<p>Yes (Conditional)</p> <p><b>Note:</b> This field is required while adding a price item parameter in a discount arrangement pricing rule type.</p>
Transaction Field	<p>Used to map to a transaction field which contains the parameter value.</p> <p><b>Note:</b></p> <p>The <b>Search</b>  icon appears corresponding to the <b>Transaction Field</b> field. On clicking the <b>Search</b>  icon corresponding to the <b>Transaction Field</b> field, the <b>Transaction Field Search</b> window appears.</p> <p>On specifying the transaction field, the description of the transaction field appears corresponding to the <b>Transaction Field</b>.</p>	<p>Yes (Conditional)</p> <p><b>Note:</b> This field is required while adding a price item parameter in a discount arrangement pricing rule type.</p>

Field Name	Field Description	Mandatory (Yes or No)
Eligible for Specific Stop-Loss	Used to indicate whether the price item parameter can be used while defining the accumulation criteria in the specific stop-loss or aggregate stop-loss pricing rules at the bill group level.	No
Eligible for Level Funding	Used to indicate whether the price item parameter can be used while defining the accumulation criteria in the level-funding pricing rules at the bill group level.	No

- Enter the required details in the **Price Item Parameters** section.
- If you want to add more than one price item parameter in a discount arrangement pricing rule type, click the **Add** (+) icon and then repeat step 2.

**Note:** However, if you want to remove a price item parameter from a discount arrangement pricing rule type, click the **Delete** (🗑️) icon corresponding to the price item parameter.

- Click **Save**.

The price item parameter is added in the discount arrangement pricing rule type.

#### **Related Topics**

For more information on...	See...
How to define a discount arrangement pricing rule type	<a href="#">Defining a Discount Arrangement Pricing Rule Type</a> on page 2608
How to edit a discount arrangement pricing rule type	<a href="#">Editing a Discount Arrangement Pricing Rule Type</a> on page 2625

## **Defining a Characteristic for a Discount Arrangement Pricing Rule Type**

### **Prerequisites**

To define characteristics for a discount arrangement pricing rule type, you should have:

- Characteristic types defined in the application (where the characteristic entity is set to **Pricing Rule Type**)

### **Procedure**

To define characteristics for a discount arrangement pricing rule type:

- Ensure that the **Characteristics** section is expanded when you are defining or editing a discount arrangement pricing rule type.

The **Characteristics** section contains the following fields in a grid:

Field Name	Field Description	Mandatory (Yes or No)
Characteristic Type	Used to indicate the characteristic type.  <b>Note:</b> The list includes only those characteristic types where the characteristic entity is set to <b>Pricing Rule Type</b> .	Yes (Conditional)  <b>Note:</b> This field is required when you are defining a characteristic for a discount arrangement pricing rule type.

Field Name	Field Description	Mandatory (Yes or No)
Characteristic Value	<p>Used to specify the value for the characteristic type.</p> <p><b>Note:</b> If you select a predefined characteristic type, the <b>Search</b>  icon appears corresponding to the <b>Characteristic Value</b> field. On clicking the <b>Search</b> icon, the <b>Predefined Characteristic Search</b> window appears.</p> <p>On specifying the value for a predefined characteristic type, the description of the characteristic value appears corresponding to the <b>Characteristic Value</b> field.</p>	<p>Yes (Conditional)</p> <p><b>Note:</b> This field is required when you are defining a characteristic for a discount arrangement pricing rule type.</p>

- Enter the required details in the **Characteristics** section.
- If you want to define more than one characteristic for a discount arrangement pricing rule type, click the **Add**  icon and then repeat step 2.

**Note:** However, if you want to remove a characteristic from a discount arrangement pricing rule type, click the **Delete**  icon corresponding to the characteristic.

- Click **Save**.

The characteristic is defined for a discount arrangement pricing rule type.

### Related Topics

For more information on...	See...
How to define a discount arrangement pricing rule type	<a href="#">Defining a Discount Arrangement Pricing Rule Type</a> on page 2608
How to edit a discount arrangement pricing rule type	<a href="#">Editing a Discount Arrangement Pricing Rule Type</a> on page 2625

## Defining the Discount Specific Data in a Discount Arrangement Pricing Rule Type



### Procedure



To add the discount-specific data in a discount arrangement pricing rule type:

- Ensure that the **DA - Specific Additional Data** section is expanded when you are defining or editing a discount arrangement pricing rule type.

The **DA - Specific Additional Data** section contains the following fields:

Field Name	Field Description	Mandatory (Yes or No)
Guaranteed Discount	<p>Used to indicate whether the discount arrangement pricing rule type is defined for discount guarantee or discount share. The valid values are:</p> <ul style="list-style-type: none"> <li><b>Yes</b> - Used when you want to create a discount guarantee pricing rule type.</li> <li><b>No</b> - Used when you want to create a discount share pricing rule type.</li> </ul>	Yes

Field Name	Field Description	Mandatory (Yes or No)
Discount Billable Charge Line Type	<p>Used to indicate a billable charge line type using which you want to create the charge line for discount.</p> <p><b>Note:</b></p> <p>The <b>Search</b>  icon appears corresponding to the <b>Discount Billable Charge Line Type</b> field. On clicking the <b>Search</b> icon, the <b>Billable Charge Line Type Search</b> window appears.</p> <p>On specifying the billable charge line type, the description of the billable charge line type appears corresponding to the <b>Discount Billable Charge Line Type</b> field.</p>	Yes
Credit Billable Charge Line Type	<p>Used to indicate a billable charge line type using which you want to create the charge line for any credit to the customer.</p> <p><b>Note:</b></p> <p>The <b>Search</b>  icon appears corresponding to the <b>Credit Billable Charge Line Type</b> field. On clicking the <b>Search</b> icon, the <b>Billable Charge Line Type Search</b> window appears.</p> <p>On specifying the billable charge line type, the description of the billable charge line type appears corresponding to the <b>Credit Billable Charge Line Type</b> field.</p>	Yes
Minimum Limit Pricing Rule Type	<p>Used to indicate the retention type enrollment based pricing rule type which you want to use while calculating the minimum limit for the discount.</p> <p><b>Note:</b></p> <p>The <b>Search</b>  icon appears corresponding to the <b>Minimum Limit Pricing Rule Type</b> field. On clicking the <b>Search</b> icon, the <b>Pricing Rule Type Search</b> window appears.</p> <p>On specifying the pricing rule type, the description of the pricing rule type appears corresponding to the <b>Minimum Limit Pricing Rule Type</b> field.</p>	<p>Yes (Conditional)</p> <p><b>Note:</b> This field is required when you are defining enrollment based minimum discount limit on the contract in a discount share pricing rule.</p>

Field Name	Field Description	Mandatory (Yes or No)
Minimum Limit Price Item	<p>Used to indicate the price item whose pricing you want to use while calculating the minimum limit for the discount.</p> <p><b>Note:</b></p> <p>The <b>Search</b>  icon appears corresponding to the <b>Minimum Limit Price Item</b> field. On clicking the <b>Search</b> icon, the <b>Price Item Details</b> window appears.</p> <p>On specifying the price item, the description of the price item appears corresponding to the <b>Minimum Limit Price Item</b> field.</p>	<p>Yes (Conditional)</p> <p><b>Note:</b> This field is required when you are defining enrollment based minimum discount limit on the contract in a discount share pricing rule.</p>
Maximum Limit Pricing Rule Type	<p>Used to indicate the retention type enrollment based pricing rule type which you want to use while calculating the maximum limit for the discount.</p> <p><b>Note:</b></p> <p>The <b>Search</b>  icon appears corresponding to the <b>Maximum Limit Pricing Rule Type</b> field. On clicking the <b>Search</b> icon, the <b>Pricing Rule Type Search</b> window appears.</p> <p>On specifying the pricing rule type, the description of the pricing rule type appears corresponding to the <b>Maximum Limit Pricing Rule Type</b> field.</p>	<p>Yes (Conditional)</p> <p><b>Note:</b> This field is required when you are defining enrollment based maximum discount limit on the contract in a discount share or discount guarantee pricing rule.</p>
Maximum Limit Price Item	<p>Used to indicate the price item whose pricing you want to use while calculating the maximum limit for the discount. Used to indicate the price item whose pricing you want to use while calculating the minimum limit for the discount.</p> <p><b>Note:</b></p> <p>The <b>Search</b>  icon appears corresponding to the <b>Maximum Limit Price Item</b> field. On clicking the <b>Search</b> icon, the <b>Price Item Details</b> window appears.</p> <p>On specifying the price item, the description of the price item appears corresponding to the <b>Maximum Limit Price Item</b> field.</p>	<p>Yes (Conditional)</p> <p><b>Note:</b> This field is required when you are defining enrollment based maximum discount limit on the contract in a discount share or discount guarantee pricing rule.</p>

2. Enter the required details in the **DA - Specific Additional Data** section.
3. Click **Save**.

The discount-specific data is added in the discount arrangement pricing rule type.

### **Related Topics**

For more information on...	See...
How to define a discount arrangement pricing rule type	<a href="#">Defining a Discount Arrangement Pricing Rule Type</a> on page 2608



For more information on...	See...
How to edit a discount arrangement pricing rule type	<a href="#">Editing a Discount Arrangement Pricing Rule Type</a> on page 2625

## Editing a Discount Arrangement Pricing Rule Type

### Prerequisites

To edit a discount arrangement pricing rule type, you should have:

- Discount arrangement pricing rule type business object defined in the application.
- Discount arrangement pricing rule business object defined in the application.

### Procedure

To edit a discount arrangement pricing rule type:

1. Click the **Admin** link in the **Application** toolbar.  
A list appears.
2. From the **Admin** menu, select **P** and then click **Pricing Rule Type**.  
A sub-menu appears.
3. Click the **Search** option from the **Pricing Rule Type** sub-menu.  
The **Pricing Rule Type** screen appears.
4. In the **Pricing Rule Type List** zone, click the **Edit** (✎) icon in the **Edit** column corresponding to the pricing rule type whose details you want to edit.

The **Discount Arrangement Pricing Rule Type** screen appears. It contains the following sections:

- **Main** – Used to specify basic details about the discount arrangement pricing rule type.
- **Algorithms** – Used to associate the algorithms with the discount arrangement pricing rule type.
- **Additional Data** – Used to specify additional information in the discount arrangement pricing rule type.
- **Price Items** – Used to add the price items for which you can define the discount arrangement pricing rules using the discount arrangement pricing rule type.
- **Price Item Parameters** – Used to add the price item parameters based on which you want to define the price item pricing.
- **Characteristics** – Used to define characteristics for the discount arrangement pricing rule type.
- **DA-Specific Additional Data** – Used to specify discount arrangement-specific additional data in a discount arrangement pricing rule type.

The **Main** section contains the following fields:

Field Name	Field Description	Mandatory (Yes or No)
Pricing Rule Type	Displays the discount arrangement pricing rule type.	Not applicable
Description	Used to specify the description for the discount arrangement pricing rule type.	Yes
Detailed Description	Used to specify additional information about the discount arrangement pricing rule type.	No

Field Name	Field Description	Mandatory (Yes or No)
Pricing Rule Business Object	<p>Used to indicate the business object using which you want to create the discount arrangement pricing rule. The valid value is:</p> <ul style="list-style-type: none"> <li>• Aggregate Stop-Loss (ASL) Pricing Rule</li> <li>• Ancillary Pricing Rule</li> <li>• Claim Pricing Rule</li> <li>• Discount Arrangement Pricing Rule</li> <li>• Flat Fee Pricing Rule</li> <li>• Level Funded (LF) Pricing Rule</li> <li>• Retention Type Claim Based Pricing Rule</li> <li>• Retention Type Enrollment Based Pricing Rule</li> <li>• Specific Stop-Loss (SSL) Pricing Rule</li> </ul> <p><b>Note:</b> You must select the <b>Discount Arrangement Pricing Rule</b> option from the <b>Pricing Rule Business Object</b> list while defining a discount arrangement pricing rule type.</p>	Yes
Business Object	Indicates the business object used while defining the discount arrangement pricing rule type.	Not applicable
Status	<p>Used to indicate the status of the discount arrangement pricing rule type. The valid values are:</p> <ul style="list-style-type: none"> <li>• Active</li> <li>• Inactive</li> </ul>	Yes
Primary	<p>Used to indicate whether the discount arrangement pricing rule type is a primary pricing rule type.</p> <p><b>Note:</b> You must not select the <b>Primary</b> option while defining the discount arrangement pricing rule type.</p>	Not applicable

Field Name	Field Description	Mandatory (Yes or No)
Pricing Rule Type Category	<p>Indicates the category to which the discount arrangement pricing rule type belongs. The valid values are:</p> <ul style="list-style-type: none"> <li>Aggregate Stop-Loss</li> <li>Ancillary</li> <li>Claim</li> <li>Discount Arrangement</li> <li>Flat Fees</li> <li>Level Funded</li> <li>Retention Type Claim Based</li> <li>Retention Type Enrollment Based</li> <li>Specific Stop-Loss</li> </ul>	No
<p><b>Note:</b> You must select the <b>Discount Arrangement</b> option from the <b>Pricing Rule Type Category</b> list while defining a discount arrangement pricing rule type.</p>		

**Tip:** Alternatively, you can edit the details of a discount arrangement pricing rule type by clicking the **Edit** button in the **Pricing Rule Type** zone.

- Modify the required details in the **Main** section.
- Ensure that the **Discount Arrangement Pricing Rule** option is selected from the **Pricing Rule Business Object** list.
- Ensure that **Primary** option is not selected when you are editing a discount arrangement pricing rule type.
- Associate the following algorithms with the discount arrangement pricing rule type:

System Event	Algorithm	Algorithm Type	Description
Account and Price Item Derivation	C1_ACCPRIDIS	C1_ACCPRIDIS	Account and Priceitem Derivation For Discount Arrangement

- Modify the additional data for a discount arrangement pricing rule type, if required.
- Add, edit, or remove price items in the discount arrangement pricing rule type, if required.
- Add, edit, or remove price item parameters in the discount arrangement pricing rule type, if required.
- Add, edit, or remove characteristics in the discount arrangement pricing rule type, if required.
- Modify the discount arrangement-specific data in the discount arrangement pricing rule type, if required.
- Click **Save**.

The changes made to the discount arrangement pricing rule type are saved.

### Related Topics

For more information on...	See...
How to associate a algorithm with the discount arrangement pricing rule type	<a href="#">Associating Algorithms with a Discount Arrangement Pricing Rule Type</a> on page 2612

For more information on...	See...
How to define additional data for discount arrangement pricing rule type	<a href="#">Defining Additional Data in a Discount Arrangement Pricing Rule Type</a> on page 2615
How to add pricing items in the discount arrangement pricing rule type	<a href="#">Adding a Price Item in a Discount Arrangement Pricing Rule Type</a> on page 2617
How to add price item parameters in the discount arrangement pricing rule type	<a href="#">Adding a Price Item Parameter in a Discount Arrangement Pricing Rule Type</a> on page 2620
How to define characteristics for the discount arrangement pricing rule type	<a href="#">Defining a Characteristic for a Discount Arrangement Pricing Rule Type</a> on page 2621
How to define discount arrangement-specific data in the pricing rule type	<a href="#">Defining the Discount Specific Data in a Discount Arrangement Pricing Rule Type</a> on page 2622

## Deleting a Discount Arrangement Pricing Rule Type

### Procedure

To delete a discount arrangement pricing rule type:

1. Click the **Admin** link in the **Application** toolbar.  
A list appears.
2. From the **Admin** menu, select **P** and then click **Pricing Rule Type**.  
A sub-menu appears.
3. Click the **Search** option from the **Pricing Rule Type** sub-menu.  
The **Pricing Rule Type** screen appears.
4. In the **Pricing Rule Type List** zone, click the **Delete** (🗑️) icon in the **Delete** column corresponding to the discount arrangement pricing rule type that you want to delete.  
A message appears confirming whether you want to delete the discount arrangement pricing rule type.

**Note:** You can delete a discount arrangement pricing rule type only when it is not yet used in the system.

**Tip:** Alternatively, you can delete a discount arrangement pricing rule type by clicking the **Delete** button in the **Pricing Rule Type** zone.

5. Click **OK**.  
The discount arrangement pricing rule type is deleted.

### Related Topics

For more information on...	See...
<b>Pricing Rule Type</b> screen	<a href="#">Pricing Rule Type</a> on page 2343
<b>Pricing Rule Type List</b> zone	<a href="#">Pricing Rule Type List</a> on page 2344
<b>Pricing Rule Type</b> zone	<a href="#">Pricing Rule Type</a> on page 2347

## Viewing the Discount Arrangement Pricing Rule Type Details

### Procedure

To view the details of a discount arrangement pricing rule type:

1. Click the **Admin** link in the **Application** toolbar.  
A list appears.
2. From the **Admin** menu, select **P** and then click **Pricing Rule Type**.  
A sub-menu appears.
3. Click the **Search** option from the **Pricing Rule Type** sub-menu.  
The **Pricing Rule Type** screen appears.
4. In the **Pricing Rule Type List** zone, click the **Broadcast** () icon corresponding to the discount arrangement pricing rule type whose details you want to view.  
The **Pricing Rule Type** zone appears.
5. View the details of the discount arrangement pricing rule type in the **Pricing Rule Type** zone.

### Related Topics

For more information on...	See...
<b>Pricing Rule Type</b> screen	<a href="#">Pricing Rule Type</a> on page 2343
<b>Pricing Rule Type List</b> zone	<a href="#">Pricing Rule Type List</a> on page 2344
<b>Pricing Rule Type</b> zone	<a href="#">Pricing Rule Type</a> on page 2347

## Defining a Discount Arrangement Pricing Rule for a Parent Customer

### Prerequisites

To define a discount arrangement pricing rule for a parent customer, you should have:

- Pricing rule type where the category is set to **Discount Arrangement**.
- Price items associated with the discount arrangement pricing rule type.

### Procedure

To define a discount arrangement pricing rule for a parent customer:

1. Search for a parent customer in the **Customer 360° View** screen.
2. In the **Search Results** section, click the **View** () icon corresponding to the parent customer whose pricing details you want to view.  
The **Person** tab appears in the **Customer 360° Information** screen.
3. Click the **Pricing** tab.  
The **Pricing** tab appears.
4. Click the **Add** link in the upper-right corner of the **Parent Customer Pricing Rules** zone.  
The **Pricing Rule** screen appears. It contains the following fields:

Field Name	Field Description	Mandatory (Yes or No)
Person Name	Indicates the parent customer for whom you want to create a discount arrangement pricing rule type.	Not applicable
Person Type	Indicates the type of the parent customer. The valid value is: <ul style="list-style-type: none"> <li>Parent Customer</li> </ul>	Not applicable
Pricing Rule Type	Used to indicate the pricing rule type using which you want to create a discount arrangement pricing rule.	Yes

- Select the required pricing rule type in the respective field.
- Click **OK**.

The **Discount Arrangement Pricing Rule** screen appears. It contains the following sections:

- Customer Information** – Displays information about the parent customer for whom you are defining the discount arrangement pricing rule. It contains the following fields:

Field Name	Field Description
Parent Customer Information	Indicates the parent customer for whom you are defining the discount arrangement pricing rule.
Pricing Rule Type	Indicates the pricing rule type using which you are defining the discount arrangement pricing rule.

- Main** – Used to specify basic details about the discount arrangement pricing rule.
- Discount Details** – Used to define eligibility criteria for a discount percentage and maximum discount amount which is allowed per claim.
- Discount Limits** – Used when you want to define minimum and maximum discount limit on the contract.
- Exclusion** – Used when you want to exclude certain network hospitals and providers during the discount share or discount guarantee calculation.
- Characteristics** – Used to define characteristics for the discount arrangement pricing rule.

**Note:** The **Discount Details**, **Discount Limits**, and **Exclusion** sections appear only when you specify a price item in the **Main** section.

The **Main** section contains the following fields:

Field Name	Field Description	Mandatory (Yes or No)
Price Item	Used to indicate the price item for which you want to define the discount arrangement pricing rule.	Yes
Pricing Start Date	Used to specify the date from when the discount arrangement pricing rule is effective. <div style="border: 1px solid black; padding: 2px; margin-top: 5px;"> <b>Note:</b> The pricing start date cannot be later than the pricing end date. </div>	Yes

Field Name	Field Description	Mandatory (Yes or No)
Pricing End Date	Used to specify the date till when the discount arrangement pricing rule is effective.  <b>Note:</b> The pricing end date cannot be earlier than the pricing start date.	No
Rate Option	Used to indicate the rate option that you want to use while defining the pricing for the price item.	Yes
Settlement Frequency	Used to indicate the settlement frequency which helps to determine the bill after date. The valid values are: <ul style="list-style-type: none"> <li>• <b>Manually (At Regular Intervals)</b> - If you select this option from the list, the bill after date which is specified in the <b>Manual Settlement Bill After Date</b> parameter while executing the <b>C1-BCDA</b> batch is stamped on the credit billable charge.</li> <li>• <b>Yearly</b> - If you select this option from the list, the bill after date in the credit billable charge is set to the pricing end date.</li> </ul> <b>Note:</b> The bill after date is stamped on the credit billable charges and not on the discount billable charges.	Yes

7. Enter the required details in the **Main** section.
8. Add the required discount details in the discount arrangement pricing rule.
9. Define the minimum and maximum discount limits on the contract in the discount arrangement pricing rule, if required.
10. Add the exclusion details of a network or a provider in the discount arrangement pricing rule, if required.
11. Define characteristics for the discount arrangement pricing rule, if required.
12. Click **Save**.

The discount arrangement pricing rule is defined for the parent customer.

### **Related Topics**

For more information on...	See...
How to search for a parent customer	<a href="#">Searching for a Person</a> on page 185
<b>Parent Customer Pricing Rules</b> zone	<a href="#">Parent Customer Pricing Rules</a> on page 231
How to add the discount details in a discount arrangement pricing rule	<a href="#">Adding the Discount Details in a Discount Arrangement Pricing Rule</a> on page 2632
How to define the discount limits in a discount arrangement pricing rule	<a href="#">Defining the Discount Limits in a Discount Arrangement Pricing Rule</a> on page 2633
How to exclude a network or provider in a discount arrangement pricing rule	<a href="#">Excluding a Network or Provider in a Discount Arrangement Pricing Rule</a> on page 2635
How to define a characteristic for a discount arrangement pricing rule	<a href="#">Defining a Characteristic for a Discount Arrangement Pricing Rule</a> on page 2636

## Adding the Discount Details in a Discount Arrangement Pricing Rule

### Prerequisites

To add the discount details in a discount arrangement pricing rule, you should have:



- Parameters defined in the application
- Parameters associated with the price item.

### Procedure

To add the discount details in a discount arrangement pricing rule:

1. Ensure that the **Discount Details** section appears when you are defining or editing a discount arrangement pricing rule.

The **Discount Details** section contains the following fields in a grid:

Field Name	Field Description	Mandatory (Yes or No)
Price Item Parameter	<p>Used to indicate the parameter using which you want to define an eligibility criteria for a discount percentage and maximum discount amount which is allowed per claim.</p> <p><b>Note:</b></p> <p>The <b>Search</b>  icon appears corresponding to the <b>Price Item Parameter</b> field. On clicking the <b>Search</b> icon, the <b>Price Item Parameter Search</b> window appears.</p> <p>On specifying the parameter, the description of the parameter appears corresponding to the <b>Price Item Parameter</b> field.</p> <p>You can only select those price item parameters which are effective during the date range specified in the discount arrangement pricing rule.</p> <p>If a parameter associated with the price item is mandatory, then by default, the parameter appears in the <b>Price Item Parameter</b> field.</p>	No
Parameter Value	<p>Used to specify the value for the price item parameter.</p> <p><b>Note:</b></p> <p>If you select a predefined parameter, the <b>Search</b>  icon appears corresponding to the <b>Parameter Value</b> field. On clicking the <b>Search</b> icon, the <b>Predefined Parameter Value Search</b> window appears.</p> <p>On specifying the parameter value, the description of the parameter value appears corresponding to the <b>Parameter Value</b> field.</p>	<p>Yes (Conditional)</p> <p><b>Note:</b> This field is required when the parameter associated with the price item is mandatory.</p>
Discount Percentage	Used to specify the discount share or discount guarantee percentage.	Yes



Field Name	Field Description	Mandatory (Yes or No)
Maximum Discount Per Claim	Used to specify the maximum discount amount which is allowed per claim. If the discount amount exceeds the maximum limit per claim, the additional amount is credited to the customer.	No

**Note:** The **Discount Details** section appears only when you specify a price item in the **Main** section.

- Enter the required details in the **Discount Details** section.
- If you want to define a discount percentage for another price item parameter and parameter value combination, click the **Add (+)** icon and then repeat step 2.

**Note:** However, if you want to remove a discount percentage for a price item parameter and parameter value combination from the discount arrangement pricing rule, click the **Delete (🗑)** icon corresponding to the combination.

- Click **Save**.

The discount details are added in the discount arrangement pricing rule.

### **Related Topics**

For more information on...	See...
How to define a discount arrangement pricing rule for a parent customer	<a href="#">Defining a Discount Arrangement Pricing Rule for a Parent Customer</a> on page 2629
How to edit a discount arrangement pricing rule of a parent customer	<a href="#">Editing a Discount Arrangement Pricing Rule of a Parent Customer</a> on page 2637

## **Defining the Discount Limits in a Discount Arrangement Pricing Rule**

### **Prerequisites**

To define the discount limits in a discount arrangement pricing rule, you should have:

- An account, to which you want to credit the discount, defined in the application
- Minimum limit pricing rule type and minimum limit price item defined in the respective discount arrangement pricing rule type when you want to define minimum discount limit on the contract
- Maximum limit pricing rule type and maximum limit price item defined in the respective discount arrangement pricing rule type when you want to define maximum discount limit on the contract

### **Procedure**

To define the discount limits in a discount arrangement pricing rule:

- Ensure that the **Discount Limits** section appears when you are defining or editing a discount arrangement pricing rule.

The **Discount Limits** section contains the following fields:

Field Name	Field Description	Mandatory (Yes or No)
No Limit	Used to indicate whether you want to define minimum or maximum discount limit on the contract.	No

Field Name	Field Description	Mandatory (Yes or No)
Discount Credit Account	Used to indicate the account to which you want to credit the discount when the minimum or maximum discount limit is defined on the contract.  <b>Note:</b> This field is enabled only when the <b>No Limit</b> option is not selected.	Yes (Conditional)  <b>Note:</b> This field is required when the <b>No Limit</b> option is not selected.
Settlement Days	Used to specify the number of days which helps to calculate the final settlement date (which is pricing end date + the settlement days). The valid values: <ul style="list-style-type: none"> <li>• 30 Days</li> <li>• 60 Days</li> <li>• 90 Days</li> <li>• 120 Days</li> <li>• 150 Days</li> <li>• 180 Days</li> </ul>	Yes

In addition, it contains the following fields in a grid:

Field Name	Field Description	Mandatory (Yes or No)
Type of Discount Limit	Displays the type of discount limit. The valid values are: <ul style="list-style-type: none"> <li>• Minimum</li> <li>• Maximum</li> </ul>	Not applicable
Select	On clicking the check box corresponding to the type of discount limit, you can define minimum or maximum discount limit on the contract.  <b>Note:</b> This field is enabled only when the <b>No Limit</b> option is not selected.	Yes
Limit Type	Used to indicate whether you want to define a flat limit or an enrollment based limit. The valid values are: <ul style="list-style-type: none"> <li>• Enrollment Based</li> <li>• Flat</li> </ul> <b>Note:</b> This field is enabled only when the <b>No Limit</b> option is not selected.  If you select the check box corresponding to the <b>Minimum</b> discount limit, the <b>Limit Type</b> field corresponding to the <b>Minimum</b> discount limit is enabled.	Yes (Conditional)  <b>Note:</b> This field is required when you are defining a minimum or maximum discount limit in the discount arrangement pricing rule.

Field Name	Field Description	Mandatory (Yes or No)
Amount Limit	Used to specify the flat minimum or maximum discount amount.  <b>Note:</b> This field is enabled only when: <ul style="list-style-type: none"> <li>The <b>No Limit</b> option is not selected.</li> <li>The minimum or maximum limit type is set to <b>Flat</b>.</li> </ul>	Yes (Conditional)  <b>Note:</b> This field is required when the minimum or maximum limit type is set to <b>Flat</b> .

**Note:** The **Discount Limits** section appears only when you specify a price item in the **Main** section.

- Enter the required details in the **Discount Limits** section.
- Click **Save**.

The discount limits are defined in the discount arrangement pricing rule.

### Related Topics

For more information on...	See...
How to define a discount arrangement pricing rule for a parent customer	<a href="#">Defining a Discount Arrangement Pricing Rule for a Parent Customer</a> on page 2629
How to edit a discount arrangement pricing rule of a parent customer	<a href="#">Editing a Discount Arrangement Pricing Rule of a Parent Customer</a> on page 2637

## Excluding a Network or Provider in a Discount Arrangement Pricing Rule

### Procedure

To exclude a network or provider in a discount arrangement pricing rule:

- Ensure that the **Exclusion** section appears when you are defining or editing a discount arrangement pricing rule.

The **Exclusion** section contains the following fields in a grid:

Field Name	Field Description	Mandatory (Yes or No)
Exclusion Level	Used to indicate whether you want to exclude the discount offered to certain network hospitals and providers during the discount share or discount guarantee calculation. The valid values are: <ul style="list-style-type: none"> <li>Network</li> <li>Provider</li> </ul> <b>Note:</b> The system creates the transaction legs and calculation lines for such excluded network hospitals and providers, but does not accumulate the discount.	Yes (Conditional)  <b>Note:</b> This field is required while excluding a network or provider in the discount arrangement pricing rule.

Field Name	Field Description	Mandatory (Yes or No)
Level Identifier	Used to specify the network or provider ID.	Yes (Conditional)  <b>Note:</b> This field is required while excluding a network or provider in the discount arrangement pricing rule.

- Enter the required details in the **Exclusion** section.
- If you want to exclude more than one network or provider in the discount arrangement pricing rule, click the **Add** (+) icon and then repeat step 2.

**Note:** However, if you want to remove a network or provider from the exclusion list, click the **Delete** (🗑️) icon corresponding to the network or provider.

- Click **Save**.

The network or provider is excluded in the discount arrangement pricing rule.

### Related Topics

For more information on...	See...
How to define a discount arrangement pricing rule for a parent customer	<a href="#">Defining a Discount Arrangement Pricing Rule for a Parent Customer</a> on page 2629
How to edit a discount arrangement pricing rule of a parent customer	<a href="#">Editing a Discount Arrangement Pricing Rule of a Parent Customer</a> on page 2637

## Defining a Characteristic for a Discount Arrangement Pricing Rule

### Prerequisites

To define a characteristic for a discount arrangement pricing rule, you should have:

- Characteristic types defined in the application (where the characteristic entity is set to **Pricing Rule**).

### Procedure

To define a characteristic for a discount arrangement pricing rule:

- Ensure that the **Characteristics** section is expanded when you are defining or editing a discount arrangement pricing rule.

The **Characteristics** section contains the following fields in the grid:

Column Name	Column Description	Mandatory (Yes or No)
Effective Date	Used to specify the date from when the characteristic is effective for the discount arrangement pricing rule.	Yes (Conditional)  <b>Note:</b> This field is required when you are defining a characteristic for the discount arrangement pricing rule.

Column Name	Column Description	Mandatory (Yes or No)
Characteristic Type	Used to indicate the characteristic type.  <b>Note:</b> The list includes only those characteristic types where the characteristic entity is set to <b>Pricing Rule</b> .	Yes (Conditional)  <b>Note:</b> This field is required when you are defining a characteristic for the discount arrangement pricing rule.
Characteristic Value	Used to specify the value for the characteristic type.  <b>Note:</b> If you select a predefined characteristic type, the <b>Search</b>  icon appears corresponding to the <b>Characteristic Value</b> field. On clicking the <b>Search</b> icon, the <b>Predefined Characteristic Search</b> window appears.  On specifying the value for a predefined characteristic type, the description of the characteristic value appears corresponding to the <b>Characteristic Value</b> field.	Yes (Conditional)  <b>Note:</b> This field is required when you are defining a characteristic for the discount arrangement pricing rule.

- Enter the required details in the **Characteristics** section.
- If you want to define more than one characteristic for the discount arrangement pricing rule, click the **Add**  icon and then repeat step 2.

**Note:** However, if you want to remove a characteristic from the discount arrangement pricing rule, click the **Delete**  icon corresponding to the characteristic.

- Click **Save**.

The characteristics are defined for the discount arrangement pricing rule.

### **Related Topics**

For more information on...	See...
How to define a discount arrangement pricing rule for a parent customer	<a href="#">Defining a Discount Arrangement Pricing Rule for a Parent Customer</a> on page 2629
How to edit a discount arrangement pricing rule of a parent customer	<a href="#">Editing a Discount Arrangement Pricing Rule of a Parent Customer</a> on page 2637

## **Editing a Discount Arrangement Pricing Rule of a Parent Customer**

### **Procedure**

To edit a discount arrangement pricing rule of a parent customer:

- Search for a parent customer in the **Customer 360° View** screen.
- In the **Search Results** section, click the **View**  icon corresponding to the parent customer whose pricing details you want to view.

The **Person** tab appears in the **Customer 360° Information** screen.

- Click the **Pricing** tab.

The **Pricing** tab appears.

- In the **Parent Customer Pricing Rules** zone, click the **Edit** (✎) icon in the **Edit** column corresponding to the discount arrangement pricing rule, whose details you want to edit.

The **Discount Arrangement Pricing Rule** screen appears. It contains the following sections:

- Customer Information** – Displays information about the parent customer for whom the discount arrangement pricing rule is defined. It contains the following fields:

Field Name	Field Description
Parent Customer Information	Indicates the parent customer for whom the discount arrangement pricing rule is defined.
Pricing Rule Type	Indicates the discount arrangement pricing rule type using which the discount arrangement pricing rule is defined.

- Main** – Used to specify basic details in the discount arrangement pricing rule.
- Discount Details** – Used to define eligibility criteria for a discount percentage and maximum discount amount which is allowed per claim.
- Discount Limits** – Used when you want to define minimum and maximum discount limit on the contract.
- Exclusion** – Used when you want to exclude certain network hospitals and providers during the discount share or discount guarantee calculation.
- Characteristics** – Used to define characteristics for the discount arrangement pricing rule.

The **Main** section contains the following fields:

Field Name	Field Description	Mandatory (Yes or No)
Price Item	Used to indicate the price item for which you want to define the discount arrangement pricing rule.	Yes
Pricing Start Date	Used to specify the date from when the discount arrangement pricing rule is effective.  <b>Note:</b> The pricing start date cannot be later than the pricing end date.	Yes
Pricing End Date	Used to specify the date till when the discount arrangement pricing rule is effective.  <b>Note:</b> The pricing end date cannot be earlier than the pricing start date.	No
Rate Option	Used to indicate the rate option that you want to use while defining the pricing for the price item.	Yes

Field Name	Field Description	Mandatory (Yes or No)
Settlement Frequency	<p>Used to indicate the settlement frequency which helps to determine the bill after date. The valid values are:</p> <ul style="list-style-type: none"> <li>• <b>Manually (At Regular Intervals)</b> - If you select this option from the list, the bill after date which is specified in the <b>Manual Settlement Bill After Date</b> parameter while executing the <b>C1-BCDA</b> batch is stamped on the credit billable charge.</li> <li>• <b>Yearly</b> - If you select this option from the list, the bill after date in the credit billable charge is set to the pricing end date.</li> </ul> <p><b>Note:</b> The bill after date is stamped on the credit billable charges and not on the discount billable charges.</p>	Yes

5. Modify the required details in the **Main** section.
6. Modify the required discount details in the discount arrangement pricing rule.
7. Modify the minimum or maximum discount limit on the contract in the discount arrangement pricing rule, if required.
8. Modify the exclusion list in the discount arrangement pricing rule, if required.
9. Define, edit, or remove characteristics from the discount arrangement pricing rule, if required.
10. Click **Save**.

The changes made to the discount arrangement pricing rule are saved.

#### Related Topics

For more information on...	See...
How to search for a parent customer	<a href="#">Searching for a Person</a> on page 185
<b>Parent Customer Pricing Rules</b> zone	<a href="#">Parent Customer Pricing Rules</a> on page 231
How to add the discount details in a discount arrangement pricing rule	<a href="#">Adding the Discount Details in a Discount Arrangement Pricing Rule</a> on page 2632
How to define the discount limits in a discount arrangement pricing rule	<a href="#">Defining the Discount Limits in a Discount Arrangement Pricing Rule</a> on page 2633
How to exclude a network or provider in a discount arrangement pricing rule	<a href="#">Excluding a Network or Provider in a Discount Arrangement Pricing Rule</a> on page 2635
How to define a characteristic for a discount arrangement pricing rule	<a href="#">Defining a Characteristic for a Discount Arrangement Pricing Rule</a> on page 2636

## Deleting a Discount Arrangement Pricing Rule of a Parent Customer

### Procedure

To delete a discount arrangement pricing rule of a parent customer:

1. Search for a parent customer in the **Customer 360° View** screen.

2. In the **Search Results** section, click the **View** () icon corresponding to the parent customer whose pricing details you want to view.

The **Person** tab appears in the **Customer 360° Information** screen.

3. Click the **Pricing** tab.

The **Pricing** tab appears.

4. In the **Parent Customer Pricing Rules** zone, click the **Delete** () icon in the **Delete** column corresponding to the discount arrangement pricing rule that you want to delete.

A message appears confirming whether you want to delete the discount arrangement pricing rule.

**Note:** You can delete a discount arrangement pricing rule only when it is not yet used in the system.

5. Click **OK**.

The discount arrangement pricing rule of a parent customer is deleted.

### Related Topics

For more information on...	See...
How to search for a parent customer	<a href="#">Searching for a Person</a> on page 185
<b>Parent Customer Pricing Rules</b> zone	<a href="#">Parent Customer Pricing Rules</a> on page 231

## Write-Off Charges during Post Runout

Oracle Revenue Management and Billing enables you to write-off the claim, specific stop-loss, aggregate stop-loss, claim based fees, enrollment based fees, ancillary, discount, and funds charges when the bill is generated in the post runout period of the policy. In this case, a write-off adjustment is created against the respective bill segment during the post bill completion. The write-off adjustment is created using the post runout write-off adjustment type which is specified in the respective pricing rule type.

To enable this feature, you need to do the following:

1. Set the **Eligible for Write-Off in Post Runout** field in the respective pricing rule type to **Yes**.
2. Specify the post runout write-off adjustment type in the respective pricing rule type.
3. Attach the **C1-PRCRLWOFF** algorithm to the **Post-Bill Completion** system event in the customer class of the accounts for which you want to write-off the charges in the post runout period of the policy.

## Level Funding Pricing

Level funding is a type of self-funding. It offers all benefits of traditional self-funding. However, it provides one additional benefit which helps to stabilize monthly costs of the self-funded employer to pay off the claim, ancillary, claim based fee, enrollment based fee, and discount charges.

Oracle Revenue Management and Billing enables you to process and bill the funds charges to the self-funded employer in either of the following ways:

- Pay the fixed flat amount in every bill period
- Pay the amount based on the enrollment based limit in every bill period

The system enables you to define whether the price items included in the claim, retention type claim based, retention type enrollment based, ancillary, and discount pricing rule types are eligible for level-funding. If the price items are eligible for level-funding, you can then include them in the level-funding pricing rule type indicating that the charges for these price items will not be included in the respective billable charge (for example, claim billable charge), but it would be settled against the funds billable charge. While adjusting such charges against the funds billable charge, there might be some surplus or deficit in funds at the time of settlement which is ideally at the end of year. In such case, the



system enables you configure whether a flat amount or percentage of surplus should be retained by the ASO provider or whether a flat amount or percentage of deficit is offered as a discount to the self-funded employer.

The pricing for the level-funding can be defined using the level-funding pricing rules. You can define a level-funding pricing rule at the parent customer and bill group levels. The level-funding pricing rule at the bill group level takes precedence over the level-funding pricing rule at the parent customer level. You can define the level-funding pricing rules for parent customers and bill groups from the **Customer 360° Information** screen. You can define a level-funding pricing rule using a level-funding pricing rule type. It is the level-funding pricing rule type which helps the system to determine:

- Business object using which the level-funding pricing rule should be created in the system.

**Note:** You must not select the **Primary** option while defining a level-funding pricing rule type.

- Algorithm which should be triggered for deriving the account and price item while creating the funds transaction legs.

**Note:** You must create an algorithm using the **C1\_ACCPRISL** algorithm type and attach it to the **Account and Price Item Derivation** system event.

- Pricing rule post-processing algorithm which should be triggered once the effective level-funding pricing rule is derived.

**Note:** A pricing rule post-processing algorithm type is not shipped with the product. You can create a custom algorithm type, if required.

- Additional generic information, such as:
  - Whether the funds charge should be written off when the bill is generated in the post runout period of the policy. In this case, a write-off adjustment is created against the respective bill segment during the post bill completion. The write-off adjustment is created using the post runout write-off adjustment type which is specified in the level-funding pricing rule type.
  - Transaction field which you want to use in the rules as the output parameter to determine whether the price item should be considered for billing.
  - Value which the output parameter in the rule should return when the price item in the level-funding pricing rule type should be considered for processing.
- Price items for which you can define level-funding pricing rules using the level-funding pricing rule type.
- Rate options that you can use while defining the pricing for the level-funded price items.
- Different type of account to which a price item should be billed based on the specified priority.
- Rule type which indicates the rules that should be executed to determine whether the price item is eligible for billing.
- Additional level-funding specific information, such as:
  - Whether the level-funding premium (i.e. funds) should be calculated using the bill period based recurring flat fee pricing rule or using the retention type enrollment based pricing rule.
  - Bill period based recurring flat fee pricing rule type or retention type enrollment based pricing rule type which you want to use for calculating the level-funded premium.
  - Price item whose pricing you want to use for calculating the level-funded premium.
  - LF billable charge line type using which you want to create billable charges for level-funded premium.
  - GL only contract type which indicates the contract against which the claim, ancillary, claim based fees, enrollment based fees, and discount charges that are settled against the funds must be debited. The distribution code on the GL only contract type will indicate the GL account against which charges settled against the funds must be debited.

- Liability distribution code will indicate the GL account against which charges settled against the funds must be credited.
- Number of days before which you want to create a To Do for reminding the self-funded employer to renew the level-funded agreement.
- Surplus billable charge line type using which you want to create the billable charge when the surplus funds are left with the ASO provider at the time of settlement.
- Deficit billable charge line type using which you want to create the billable charge when the funds are in deficit at the time of settlement.
- Domestic provider billable charge line type using which you want to create billable charges for the claim, claim based fees, enrollment based fees, ancillary, and discount charges which are settled against the funds for a domestic provider.
- Markup or markdown billable charge line type using which you want to create billable charges for markup or markdown which are settled against the funds.
- Rule type which indicates the rules that should be executed to determine whether the markup or markdown calculation line is eligible for billing.
- Transaction field which you want to use in the rules as the output parameter to determine whether the markup or markdown calculation line is eligible for billing.
- Rule type which indicates the rules that should be executed to determine whether the level-funded premium is for a domestic provider.
- Transaction field which you want to use in the rules as the output parameter to determine whether the level-funded premium is for a domestic provider.

Once a level-funding pricing rule type is defined, you can create level-funding pricing rules using the level-funding pricing rule type. While defining a level-funding pricing rule for a parent customer, you need to specify the following:

- Price item for which you want to define the pricing.
- Specific stop-loss pricing rule of the parent customer whose accumulation parameters you want to inherit for the level-funding. On selecting a specific stop-loss pricing rule, the level-funding pricing date range is set automatically. The level-funding pricing date range is same as the specific stop-loss pricing rule.
- Rate option which you want to use while defining the level-funding pricing.
- Settlement frequency which helps to determine the bill after date. The valid values are:
  - **Immediately** – If you select this option from the list, the bill after date is not calculated. The funds billable charge is billed immediately in the next bill cycle.
  - **Manually (At Required Intervals)** - If you select this option from the list, the bill after date which is specified in the **Manual Settlement Bill After Date** parameter while executing the **C1-BCLF** batch is stamped on the funds billable charge.
  - **Never** - If you select this option from the list, the bill after date which is specified in the **Manual Settlement Bill After Date** parameter while executing the **C1-BCLF** batch is stamped on the funds billable charge.
  - **Yearly** – If you select this option from the list, the bill after date is set to the pricing end date in the funds billable charge.
  - **On Settlement** - If you select this option from the list, the bill after date is set to the settlement date in the funds billable charge.

**Note:** The accumulation parameters, such as incurred start date, incurred end date, paid start date, paid end date, and settlement days are automatically inherited from the parent customer's specific stop-loss pricing rule. You cannot change any accumulation parameter except the settlement days.

- Settlement days which helps to calculate the settlement date (which is pricing end date, incurred end date, or paid end date whichever is later + the settlement days)
- Whether the customer would like to renew or cancel the level-funded agreement.
- Whether a flat amount or percentage of surplus should be retained by the ASO provider at the time of settlement.
- Whether a flat amount or percentage of deficit should be offered as discount to the self-funded employer at the time of settlement.

However, while defining a level-funding pricing rule for a bill group, you need to specify the following:

- The policy status in which the level-funding pricing rule is applicable.
- Price item for which you want to define the pricing.
- Parent customer's level-funding pricing rule from which you want to inherit the accumulation parameters.

**Note:**

The pricing date range is derived from the parent customer's level-funding pricing rule because the level-funding pricing rules for parent customer and bill group should have the same date range.

The settlement fund price item is derived from the level-funding pricing rule type using which the level-funding pricing rule is created.

- Rate option which you want to use while defining the level-funding pricing.
- Price items whose charges should be accumulated against the level funded price items so that it can be settled against the funds.
- Whether the line items and markup or markdown in a particular claim pricing rule should be accumulated.

**OR**

Whether the line items which are associated with the **Level Funded** pricing rule type category should be accumulated.

- Whether the charges created using the billable charge line types in a particular ancillary pricing rule should be accumulated.

**OR**

Whether the charges created using the billable charge line types where the **Pricing Rule Type Category** characteristic is set to **Ancillary** should be accumulated.

- Whether the discount calculated using a particular discount arrangement pricing rule should be accumulated.
- Whether the charges calculated using the retention type claim based or retention type enrollment based pricing for a price item should be accumulated.

You can also specify a pricing group while defining a level-funding pricing rule for a bill group. Once a level-funding pricing rule is defined for a bill group, the system creates a price assignment in a price list and assigns the price list to the bill group.

The following new batches are introduced in this release:

- **C1-ACLF** – This batch is used to accumulate the charges which are to be settled against the funds. During the accumulation post-processing, the level funded billable charges (which are created through the TFM process) are posted against the GL accounts which are derived using the GL only contract type and liability distribution code information in the level-funding pricing rule type. For more information about the batch, refer to *Oracle Revenue Management and Billing Batch Guide*.
- **C1-BCLF** – Once the level funded billable charges are accumulated, this batch is used to create the accumulated level funded billable charges. It is also used to calculate the bill after date. For more information about the batch, refer to *Oracle Revenue Management and Billing Batch Guide*.

## Defining a Level Funded Pricing Rule Type

### Prerequisites

To define a level funded pricing rule type, you should have:

- Level Funded Pricing Rule Type business object defined in the application.
- Level Funded Pricing Rule business object defined in the application.

### Procedure

To define a level funded pricing rule type:

1. Click the **Admin** link in the **Application** toolbar.

A list appears.

2. From the **Admin** menu, select **P** and then click **Pricing Rule Type**.

A sub-menu appears.

3. Click the **Add** option from the **Pricing Rule Type** sub-menu.

The **Select Business Object** screen appears. It contains the following field:

Field Name	Field Description	Mandatory (Yes or No)
Pricing Rule Type Business Object	Used to indicate the business object using which you want to create a level funded pricing rule type.  <b>Note:</b> You can create a discount arrangement pricing rule type using the <b>Level Funded Pricing Rule Type (C1-PricingRuleTypeDA)</b> business object.	Yes

**Tip:** Alternatively, you can access this screen by clicking the **Add** button in the **Page Title** area of the **Pricing Rule Type** screen.

4. Select the **Level Funded (LF) Pricing Rule Type** option from the **Pricing Rule Type Business Object** list.
5. Click **OK**.

The **Level Funded Pricing Rule Type** screen appears. It contains the following sections:

- **Main** – Used to specify the basic details about the level funded pricing rule type.
- **Algorithms** – Used to associate the algorithms with a level funded pricing rule type.
- **Additional Data** – Used to specify the additional information about the level funded pricing rule type.
- **Price Items** – Used to add the price items for which you can define the level funded pricing rules using the level funded pricing rule type.
- **Price Item Parameters** – Used to add the price item parameters based on which you want to define the price item pricing.
- **Characteristics** – Used to define the characteristics for a level funded pricing rule type.
- **DA – Specific Additional Data** – Used to define the level funded - specific additional data in a discount arrangement pricing rule type.

The **Main** section contains the following fields:

Field Name	Field Description	Mandatory (Yes or No)
Pricing Rule Type	Used to specify the level funded pricing rule type.	Yes
Description	Used to specify the description for the level funded pricing rule type.	Yes
Detailed Description	Used to specify additional information about the level funded pricing rule type.	No
Pricing Rule Business Object	Used to indicate the business object using which you want to create the level funded pricing rule. The valid value is: <ul style="list-style-type: none"> <li>Level Funded (LF) Pricing Rule</li> </ul>	Yes
Business Object	Indicates the business object using which you are defining the level funded pricing rule type.	Not applicable
Status	Used to indicate the status of the level funded pricing rule type. The valid values are: <ul style="list-style-type: none"> <li>Active</li> <li>Inactive</li> </ul>	Yes
Primary	Used to indicate whether the pricing rule type is a primary pricing rule type. <div style="border: 1px solid black; padding: 2px; margin-top: 5px;"> <b>Note:</b> You must not select the <b>Primary</b> option while defining a level funded pricing rule type. </div>	Not applicable
Pricing Rule Type Category	Used to indicate the category to which the pricing rule type belongs. The valid value is: <ul style="list-style-type: none"> <li>Level Funded</li> </ul>	Yes

6. Enter the required details in the **Main** section.
7. Ensure that **Primary** option is not selected when you are defining a level funded pricing rule type.
8. Associate the following algorithms with the discount arrangement pricing rule type:

System Event	Algorithm	Algorithm Type	Description
Account and Price Item Derivation	C1_ACCPRISL	C1_ACCPRISL	Account and Priceitem Derivation For Level Funded
Accumulation Post Processing	C1-LFACPOST	C1-LFACPOST	Level Funded Accumulation Post Processing

9. Define additional data for a level funded pricing rule type, if required.
10. Add the required price items in the level funded pricing rule type.
11. Add the price item parameters in the level funded pricing rule type, if required.
12. Define characteristics for a level funded pricing rule type, if required.
13. Add level funded-specific additional data in the level funded pricing rule type.
14. Click **Save**.

The level funded pricing rule type is defined.

### Related Topics

For more information on...	See...
How to associate algorithms with the level funded pricing rule type	<a href="#">Associating an Algorithm with a Level Funded Pricing Rule Type</a> on page 2646
How to define additional data for a level funded pricing rule type	<a href="#">Defining Additional Data in a Level Funded Pricing Rule Type</a> on page 2647
How to add price items in the level funded pricing rule type	<a href="#">Adding a Price Item in a Level Funded Pricing Rule Type</a> on page 2649
How to add price item parameters in the level funded pricing rule type	<a href="#">Adding a Price Item Parameter in a Level Funded Pricing Rule Type</a> on page 2652
How to define characteristics for a level funded pricing rule type	<a href="#">Defining Characteristics for a Level Funded Pricing Rule Type</a> on page 2653
How to add level funded - specific data in the discount arrangement pricing rule type	<a href="#">Defining the Level Funded Specific Additional Data in a Level Funded Pricing Rule Type</a> on page 2654

## Associating an Algorithm with a Level Funded Pricing Rule Type

### Prerequisites

To associate algorithms with a level funding pricing rule type, you should have:

- An algorithm defined using the **C1\_ACCPRIDIS** algorithm type.



### Procedure

To associate algorithms with a discount arrangement pricing rule type:

1. Ensure that the **Algorithms** section is expanded when you are defining or editing the discount arrangement pricing rule type.

The **Algorithms** section contains the following columns in a grid:

Column Name	Column Description	Mandatory (Yes or No)
System Event	Used to indicate the system event when you want to invoke the algorithm. The valid values are: <ul style="list-style-type: none"> <li>• Account and Price Item Derivation</li> <li>• Accumulation Billable Charge Post Proc</li> <li>• Accumulation Billable Charge Pre Proc</li> <li>• Accumulation Post Processing</li> <li>• Accumulation Pre Processing</li> <li>• Pricing Rule Post Processing</li> <li>• Transaction Validation</li> </ul>	Yes  <b>Note:</b> This field is required when you are associating an algorithm with the discount arrangement pricing rule type.

Column Name	Column Description	Mandatory (Yes or No)
Sequence	Used to specify the order in which the algorithms for each system event must be executed.	Yes (Conditional)  <b>Note:</b> This field is required when you are associating an algorithm with the discount arrangement pricing rule type.
Algorithm	Used to specify the algorithm.  <b>Note:</b> Once you select the system event, the <b>Search</b>  icon appears corresponding to the <b>Algorithm</b> field. On clicking the <b>Search</b>  icon, the <b>Algorithm Search</b> window appears.  On specifying the algorithm, the description of the algorithm appears corresponding to the <b>Algorithm</b> field.	Yes (Conditional)  <b>Note:</b> This field is required when you are associating an algorithm with the discount arrangement pricing rule type.

2. Enter the following details in the **Algorithms** section:

System Event	Sequence	Algorithm
Account and Price Item Derivation	10	C1_ACCPRIDIS

3. If you want to associate more than one algorithm with the discount arrangement pricing rule type, click the **Add**  icon and then repeat step 2.

**Note:** However, if you want to disassociate an algorithm from the discount arrangement pricing rule type, click the **Delete**  icon corresponding to the algorithm.

4. Click **Save**.

The algorithms are associated with the discount arrangement pricing rule type.

### **Related Topics**

For more information on...	See...
How to define the discount arrangement pricing rule type	<a href="#">Defining a Discount Arrangement Pricing Rule Type</a> on page 2608
How to edit the discount arrangement pricing rule type	<a href="#">Editing a Discount Arrangement Pricing Rule Type</a> on page 2625

## **Defining Additional Data in a Level Funded Pricing Rule Type**

### **Procedure**

To define additional data in a level funded pricing rule type:

1. Ensure that the **Additional Data** section is expanded when you are defining or editing a level funded pricing rule type.

The **Additional Data** section contains the following fields:

Field Name	Field Description	Mandatory (Yes or No)
Eligible for Specific Stop-Loss	Used to indicate whether price items included in the level funded pricing rule type are eligible for specific stop-loss. The valid values are: <ul style="list-style-type: none"> <li>• Yes</li> <li>• No</li> </ul>	No
Eligible for Level Funding	Used to indicate whether price items included in the level funded pricing rule type are eligible for level funding. The valid values are: <ul style="list-style-type: none"> <li>• Yes</li> <li>• No</li> </ul>	No
Run-in Identifier Value	Used to specify the identifier value to determine whether the level funded transaction is received during the run-in period of the policy.	No
Third Party Identifier Value	Used to specify the identifier value to determine whether the level funded transaction is received from an external source system.	No
Accumulation Only Identifier Value	Used to specify the identifier value to determine whether the level funded transaction contains the accumulated information of ASL, SSL, and Level Funding pricing types.	No
Eligible for Write-Off in Post Runout	Used to indicate whether the level funded charges should be written off when the bill is generated in the post runout period of the policy. The valid values are: <ul style="list-style-type: none"> <li>• Yes</li> <li>• No</li> </ul> <div style="border: 1px solid black; padding: 2px; margin-top: 5px;"> <b>Note:</b> For more information, refer to the <a href="#">Write-Off Charges during Post Runout</a> section. </div>	No
Post Runout Write-Off Adjustment Type	Used to specify the adjustment type using which you want to create post runout write-off adjustment. <div style="border: 1px solid black; padding: 5px; margin-top: 5px;"> <b>Note:</b>  This field appears when the <b>Eligible for Write-Off in Post Runout</b> field is set to <b>Yes</b>.   The <b>Search</b>  icon appears corresponding to the <b>Post Runout Write-Off Adjustment Type</b> field. On clicking the <b>Search</b> icon, the <b>Adjustment Type Search</b> window appears.   On specifying the adjustment type, the description of the adjustment type appears corresponding to the <b>Eligible for Write-Off in Post Runout</b> field. </div>	Yes (Conditional) <div style="border: 1px solid black; padding: 5px; margin-top: 5px;"> <b>Note:</b> This field is required when the <b>Eligible for Write-Off in Post Runout</b> field is set to <b>Yes</b>. </div>



Field Name	Field Description	Mandatory (Yes or No)
Rule Based Price Item Eligibility Field	<p>Used to indicate the transaction field which you want to use in the rules as the output parameter to determine whether the price item should be considered for billing.</p> <p><b>Note:</b></p> <p>For more information, refer to the <a href="#">Price Item Eligibility</a> on page 2726 section.</p> <p>This field appears when the <b>Eligible for Write-Off in Post Runout</b> field is set to <b>Yes</b>.</p> <p>The <b>Search</b> (🔍) icon appears corresponding to the <b>Rule Based Price Item Eligibility Field</b> field. On clicking the <b>Search</b> icon, the <b>Field Search</b> window appears.</p> <p>On specifying the field name, the description of the field name appears corresponding to the <b>Rule Based Price Item Eligibility Field</b>.</p>	No
Rule Based Eligibility Value	<p>Used to specify the value which the output parameter in the rule should return when the price item in the discount arrangement pricing rule type should be considered for processing.</p>	Yes (Conditional)

2. Enter the required details in the **Additional Data** section.
3. Click **Save**.

The additional data is defined for the pricing rule type.

### Related Topics

For more information on...	See...
How to define a level funded pricing rule type	<a href="#">Defining a Level Funded Pricing Rule Type</a> on page 2644
How to edit a level funded pricing rule type	<a href="#">Editing a Level Funded Pricing Rule Type</a> on page 2658

## Adding a Price Item in a Level Funded Pricing Rule Type

### Prerequisites

To add a price item in a level funded pricing rule type, you should have:

- Price item defined in the application
- Rate options defined in the **Rate Option (C1-ExtLookRetTypeRateOpt)** extendable lookup
- Values defined for the **Invoice Type (C1INVTYP)** characteristic type
- The **C1INVTYP** characteristic type set in the **Invoice Type Characteristic Type** option type of the **C1-ASOBLNG** feature configuration





- Rule types defined in the application (where the rule type usage is set to **Price Item Eligibility**)





### **Procedure**

To add a price item in a level funded pricing rule type:

1. Ensure that the **Price Items** section is expanded when you are defining or editing a level funded pricing rule type.

The **Price Items** section contains the following fields in a grid:

Field Name	Field Description	Mandatory (Yes or No)						
Price Item	<p>Used to indicate the price item that you want to include in the level funded pricing rule type.</p> <p><b>Note:</b></p> <p>The <b>Search</b> () icon appears corresponding to the <b>Price Item</b> field. On clicking the <b>Search</b> icon, the <b>Price Item Search</b> window appears.</p> <p>On specifying the price item, the description of the price item appears corresponding to the <b>Price Item</b> field.</p>	<p>Yes (Conditional)</p> <p><b>Note:</b> This field is required when you are adding a rate option and bill to account in the level funded pricing rule type.</p>						
Rate Option	<p>Used to indicate one or more rate options which are valid for a price item.</p> <p>On clicking the <b>Add</b> () icon, the following field appears in a grid:</p> <table border="1"> <thead> <tr> <th>Field Name</th> <th>Field Description</th> <th>Mandatory (Yes or No)</th> </tr> </thead> <tbody> <tr> <td>Rate Option</td> <td>Used to indicate the rate option that you want to use while defining pricing for the price item.</td> <td>Yes</td> </tr> </tbody> </table> <p><b>Note:</b></p> <p>If you want to define more than one rate option to the price item in the level funded pricing rule type, click the <b>Add</b> () icon.</p> <p>However, if you want to remove a price item from a level funded pricing rule type, click the <b>Delete</b> () icon corresponding to the <b>Rate Option</b> field.</p>	Field Name	Field Description	Mandatory (Yes or No)	Rate Option	Used to indicate the rate option that you want to use while defining pricing for the price item.	Yes	Not applicable
Field Name	Field Description	Mandatory (Yes or No)						
Rate Option	Used to indicate the rate option that you want to use while defining pricing for the price item.	Yes						

Field Name	Field Description	Mandatory (Yes or No)									
Bill To Account	<p>Used to indicate a order in which the account should be considered while deriving a transaction leg.</p> <p>On clicking the <b>Add</b> () icon, the following fields appear in a grid:</p> <table border="1"> <thead> <tr> <th>Field Name</th> <th>Field Description</th> <th>Mandatory (Yes or No)</th> </tr> </thead> <tbody> <tr> <td>Priority</td> <td>Used to specify the order in which the invoice type is considered for a price item.</td> <td>Yes</td> </tr> <tr> <td>Invoice Type</td> <td>Used to indicate the type which is considered for billing. For more information, refer to the <a href="#">Bill Group's Account</a> on page 55 section.</td> <td>Yes</td> </tr> </tbody> </table> <div style="border: 1px solid black; padding: 5px; margin-top: 10px;"> <p><b>Note:</b> The <b>Search</b> () icon appears corresponding to the <b>Invoice Type</b> field. On clicking the <b>Search</b> icon, the <b>Invoice Type Search</b> window appears.</p> </div> <div style="background-color: #f0f0f0; padding: 10px; margin-top: 10px;"> <p><b>Note:</b></p> <p>If you want to define more than one invoice type to the price item in a level funded pricing rule type, click the <b>Add</b> () icon.</p> <p>However, if you want to remove a invoice type from the price item in a level funded pricing rule type, click the <b>Delete</b> () icon corresponding to the <b>Priority</b> field.</p> </div>	Field Name	Field Description	Mandatory (Yes or No)	Priority	Used to specify the order in which the invoice type is considered for a price item.	Yes	Invoice Type	Used to indicate the type which is considered for billing. For more information, refer to the <a href="#">Bill Group's Account</a> on page 55 section.	Yes	Not applicable
Field Name	Field Description	Mandatory (Yes or No)									
Priority	Used to specify the order in which the invoice type is considered for a price item.	Yes									
Invoice Type	Used to indicate the type which is considered for billing. For more information, refer to the <a href="#">Bill Group's Account</a> on page 55 section.	Yes									
Eligibility Rule Type	Used to indicate the rule type which indicates the rules that should be executed to determine whether the price item is eligible for billing.	No									

2. Enter the required details in the **Price Items** section.
3. If you want to define more than one price item in a level funded pricing rule type, click the **Add** () icon and then repeat step 2.

**Note:** However, if you want to remove a price item from a level funded pricing rule type, click the **Delete** () icon corresponding to the **Price Item** field.

4. Click **Save**.

The price items are added for a level funded pricing rule type.

### Related Topics

For more information on...	See...
How to define a level funded pricing rule type	<a href="#">Defining a Level Funded Pricing Rule Type</a> on page 2644
How to edit a level funded pricing rule type	<a href="#">Editing a Level Funded Pricing Rule Type</a> on page 2658

## Adding a Price Item Parameter in a Level Funded Pricing Rule Type

### Prerequisites

To add a price item parameter in a level funded pricing rule type, you should have:





- Parameter defined in the application where parameter usage is set to **Price Item**.
- Parameter associated with the price item.
- Transaction fields defined in the application.

### Procedure

To add a price item parameter in a level funded pricing rule type:

1. Ensure that the **Price Item Parameters** section is expanded when you are defining or editing a level funded pricing rule type.

The **Price Item Parameters** section contains the following fields in a grid:

Field Name	Field Description	Mandatory (Yes or No)
Price Item Parameter	<p>Used to specify the parameter which you can use while defining a level funded pricing for the price item.</p> <p><b>Note:</b></p> <p>The <b>Search</b>  icon appears corresponding to the <b>Price Item Parameter</b> field. On clicking the <b>Search</b>  icon corresponding to the <b>Price Item Parameter</b> field, the <b>Parameter Search</b> window appears.</p> <p>On specifying the parameter, the description of the price item parameter appears corresponding to the <b>Price Item Parameter</b> field.</p>	<p>Yes (Conditional)</p> <p><b>Note:</b> This field is required when you are adding a price item parameter in a level funded pricing rule type.</p>
Transaction Field	<p>Used to specify the transaction field from where the data should be retrieved.</p> <p><b>Note:</b></p> <p>The <b>Search</b>  icon appears corresponding to the <b>Transaction Field</b> field. On clicking the <b>Search</b>  icon corresponding to the <b>Transaction Field</b> field, the <b>Transaction Field Search</b> window appears.</p> <p>On specifying the transaction field, the description of the transaction field appears corresponding to the <b>Transaction Field</b>.</p>	<p>Yes (Conditional)</p> <p><b>Note:</b> This field is required when you are adding a price item parameter in a level funded pricing rule type.</p>

Field Name	Field Description	Mandatory (Yes or No)
Eligible for Specific Stop-Loss	Used to indicate whether the price item parameter can be used while defining the accumulation criteria in the specific stop-loss or aggregate stop-loss pricing rule.	No
Eligible for Level Funding	Used to specify whether the price item parameter can be used in level funding.	No

- Enter the required details in the **Price Item Parameters** section.
- If you want to add more than one price item parameter in a level funded pricing rule type, click the **Add** (+) icon and then repeat step 2.

**Note:** However, if you want to remove a price item parameter from a level funded pricing rule type, click the **Delete** (🗑️) icon corresponding to the price item parameter.

- Click **Save**.

The price item parameter is added for a level funded pricing rule type.

### Related Topics

For more information on...	See...
How to define a level funded pricing rule type	<a href="#">Defining a Level Funded Pricing Rule Type</a> on page 2644
How to edit a level funded pricing rule type	<a href="#">Editing a Level Funded Pricing Rule Type</a> on page 2658

## Defining Characteristics for a Level Funded Pricing Rule Type

### Prerequisites

To define characteristics for a level funded pricing rule type, you should have:

- Characteristic types defined in the application (where the characteristic entity is set to **Pricing Rule Type**)

### Procedure

To define characteristics for a level funded pricing rule type:

- Ensure that the **Characteristics** section is expanded when you are defining or editing a discount arrangement pricing rule type.

The **Characteristics** section contains the following columns in a grid:

Field Name	Field Description	Mandatory (Yes or No)
Characteristic Type	Used to indicate the characteristic type. <b>Note:</b> The list includes only those characteristic types where the characteristic entity is set to <b>Pricing Rule Type</b> .	Yes (Conditional) <b>Note:</b> This field is required when you are defining a characteristic for a level funded pricing rule type.

Field Name	Field Description	Mandatory (Yes or No)
Characteristic Value	Used to specify the value for the characteristic type.  <b>Note:</b> On specifying the value for a predefined characteristic type, the description of the characteristic value appears corresponding to the <b>Characteristic Value</b> field.	Yes (Conditional)  <b>Note:</b> This field is required when you are defining a characteristic for a level funded pricing rule type.

- Enter the required details in the **Characteristics** section.

**Note:** If you select a predefined characteristic type, the **Search** (🔍) icon appears corresponding to the **Characteristic Value** field. On clicking the **Search** icon, you can search for a predefined characteristic value.

- If you want to define more than one characteristic for a level funded pricing rule type, click the **Add** (+) icon and then repeat step 2.

**Note:** However, if you want to remove a characteristic from a level funded pricing rule type, click the **Delete** (🗑️) icon corresponding to the characteristic.

- Click **Save**.

The characteristics are defined for a level funded pricing rule type.

#### Related Topics

For more information on...	See...
How to define a level funded pricing rule type	<a href="#">Defining a Level Funded Pricing Rule Type</a> on page 2644
How to edit a level funded pricing rule type	<a href="#">Editing a Level Funded Pricing Rule Type</a> on page 2658

## Defining the Level Funded Specific Additional Data in a Level Funded Pricing Rule Type

### Prerequisites

To define level funded specific additional data in a level funded pricing rule type, you should have:







- A rule type defined for **Markup or Markdown Eligibility Rule Type** and **Domestic Provider Eligibility Rule Type** field.

### Procedure

To add the level-funded data in a level funded pricing rule type:







- Ensure that the **Level Funded - Specific Additional Data** section is expanded when you are defining or editing a level funded pricing rule type.

The **Level Funded - Specific Additional Data** section contains the following fields:

Field Name	Field Description	Mandatory (Yes or No)
Funding Arrangement	<p>Used to indicate whether the level-funded premium (i.e. funds) should be calculated using the bill period based recurring flat fee pricing rule or using the retention type enrollment based pricing rule. The valid values are:</p> <ul style="list-style-type: none"> <li>• Enrollment Based Premium</li> <li>• Flat Rate Based Premium</li> </ul>	Yes
Settlement Fund Pricing Rule Type	<p>Used to indicate the bill period based recurring flat fee pricing rule type or the retention type enrollment based pricing rule type which you want to use for calculating the level-funded premium.</p> <div style="border: 1px solid black; padding: 5px;"> <p><b>Note:</b></p> <p>The <b>Search</b>  icon appears corresponding to the <b>Settlement Fund Pricing Rule Type</b> field. On clicking the <b>Search</b>  icon corresponding to the <b>Settlement Fund Pricing Rule Type</b> field, the <b>Contract Type Search</b> window appears.</p> <p>On specifying the contract type, the description of the contact type appears corresponding to the <b>Settlement Fund Pricing Rule Type</b> field.</p> </div>	Yes
Settlement Fund Price Item	<p>Used to indicate the price item that you want to use for calculating the level-funded premium.</p> <div style="border: 1px solid black; padding: 5px;"> <p><b>Note:</b></p> <p>The <b>Search</b>  icon appears corresponding to the <b>Settlement Fund Price Item</b> field. On clicking the <b>Search</b>  icon corresponding to the <b>Settlement Fund Price Item</b> field, the <b>Price Item Details</b> window appears.</p> <p>On specifying the price item details, the description of the price item details appears corresponding to the <b>Settlement Fund Price Item</b> field.</p> </div>	Yes
LF Billable Charge Line Type	<p>Used to indicate the level funded billable charge line type using which you want to create the billable charges for level-funded settlement purposes.</p> <div style="border: 1px solid black; padding: 5px;"> <p><b>Note:</b></p> <p>The <b>Search</b>  icon appears corresponding to the <b>LF Billable Charge Line Type</b> field. On clicking the <b>Search</b>  icon corresponding to the <b>LF Billable Charge Line Type</b> field, the <b>Billable Charge Line Type Search</b> window appears.</p> <p>On specifying the billable charge line type, the description of the billable charge line type appears corresponding to the <b>Billable Charge Line Type Search</b> field.</p> </div>	Yes

Field Name	Field Description	Mandatory (Yes or No)
GL Only Contract Type	<p>Used to indicate the contract against which the level-funded billable charges for claim, ancillary, claim based fees, enrollment based fees, discount, specific stop-loss, and aggregate stop-loss must be debited.</p> <p><b>Note:</b></p> <p>The <b>Search</b> (🔍) icon appears corresponding to the <b>GL Only Contract Type</b> field. On clicking the <b>Search</b> (🔍) icon corresponding to the <b>GL Only Contract Type</b> field, the <b>Contract Type Search</b> window appears.</p>	Yes
Liability Distribution Code	<p>Used to indicate the GL account against which the level-funded billable charges (that are settled against the level-funded premium billable charge) must be credited.</p> <p><b>Note:</b></p> <p>The <b>Search</b> (🔍) icon appears corresponding to the <b>Liability Distribution Code</b> field. On clicking the <b>Search</b> (🔍) icon corresponding to the <b>Liability Distribution Code</b> field, the <b>Distribution Code Search</b> window appears.</p> <p>On specifying the distribution code, the description of the distribution code appears corresponding to the <b>Liability Distribution Code</b> field.</p>	Yes
Renewal Decision Lead Time	<p>Used to specify the number of days before which you want to create a To Do for reminding the self-funded employer to renew the level-funded agreement.</p>	Yes
Surplus Billable Charge Line Type	<p>Used to indicate the surplus billable charge line type using which you want to create the billable charge when the surplus funds are left with the ASO provider at the time of settlement.</p> <p><b>Note:</b></p> <p>The <b>Search</b> (🔍) icon appears corresponding to the <b>Surplus Billable Charge Line Type</b> field. On clicking the <b>Search</b> (🔍) icon corresponding to the <b>Surplus Billable Charge Line Type</b> field, the <b>Billable Charge Line Type Search</b> window appears.</p> <p>On specifying the billable charge line type, the description of the billable charge line type appears corresponding to the <b>Surplus Billable Charge Line Type</b> field.</p>	Yes



Field Name	Field Description	Mandatory (Yes or No)
Deficit Billable Charge Line Type	<p>Used to indicate the deficit billable charge line type using which you want to create the billable charge when the funds are in deficit at the time of settlement.</p> <p><b>Note:</b></p> <p>The <b>Search</b>  icon appears corresponding to the <b>Deficit Billable Charge Line Type</b> field. On clicking the <b>Search</b>  icon corresponding to the <b>Deficit Billable Charge Line Type</b> field, the <b>Billable Charge Line Type Search</b> window appears.</p> <p>On specifying the billable charge line type, the description of the billable charge line type appears corresponding to the <b>Deficit Billable Charge Line Type</b> field.</p>	Yes
Domestic Provider Billable Charge Line Type	<p>Used to indicate the domestic provider billable charge line type using which you want to create level-funded settlement billable charge for a domestic provider.</p> <p><b>Note:</b></p> <p>The <b>Search</b>  icon appears corresponding to the <b>Domestic Provider Billable Charge Line Type</b> field. On clicking the <b>Search</b>  icon corresponding to the <b>Domestic Provider Billable Charge Line Type</b> field, the <b>Billable Charge Line Type Search</b> window appears.</p> <p>On specifying the billable charge line type, the description of the billable charge line type appears corresponding to the <b>Domestic Provider Billable Charge Line Type</b> field.</p>	No
Markup or Markdown Billable Charge Line Type	<p>Used to indicate the markup or markdown billable charge line type using which you want to create the billable charges for markup or markdown which are settled against the level-funded premium.</p> <p><b>Note:</b></p> <p>The <b>Search</b>  icon appears corresponding to the <b>Markup or Markdown Billable Charge Line Type</b> field. On clicking the <b>Search</b>  icon corresponding to the <b>Markup or Markdown Billable Charge Line Type</b> field, the <b>Billable Charge Line Type Search</b> window appears.</p> <p>On specifying the billable charge line type, the description of the billable charge line type appears corresponding to the <b>Markup or Markdown Billable Charge Line Type</b> field.</p>	No
Markup or Markdown Eligibility Rule Type	Used to indicate the rules that should be executed to determine whether the markup or markdown calculation line is eligible for billing.	No

Field Name	Field Description	Mandatory (Yes or No)
Rule Based Markup or Markdown Eligibility Field	<p>Used to indicate the transaction field which you want to use in the rules as the output parameter to determine whether the markup or markdown calculation line is eligible for billing.</p> <p><b>Note:</b></p> <p>The <b>Search</b> (🔍) icon appears corresponding to the <b>Rule Based Markup or Markdown Eligibility Field</b> field. On clicking the <b>Search</b> (🔍) icon corresponding to the <b>Rule Based Markup or Markdown Eligibility Field Type</b> field, the <b>Field Search</b> window appears.</p> <p>On specifying the eligibility field, the description of the field appears corresponding to the <b>Rule Based Markup or Markdown Eligibility Field</b> field.</p>	<p>Yes (Conditional)</p> <p><b>Note:</b> This field is required when you are specifying a markup or markdown eligibility rule type in a level funded pricing rule type.</p>
Domestic Provider Eligibility Rule Type	Used to indicate the rules that should be executed to determine whether the level-funded premium is for a domestic provider.	No
Rule Based Domestic Provider Claim Eligibility Field	<p>Used to indicate the transaction field which you want to use in the rules as the output parameter to determine whether the level-funded premium is for a domestic provider.</p> <p><b>Note:</b></p> <p>The <b>Search</b> (🔍) icon appears corresponding to the <b>Rule Based Domestic Provider Claim Eligibility Field</b> field. On clicking the <b>Search</b> (🔍) icon corresponding to the <b>Rule Based Domestic Provider Claim Eligibility Field</b> field, the <b>Field Search</b> window appears.</p> <p>On specifying the eligibility field, the description of the field appears corresponding to the <b>Rule Based Domestic Provider Claim Eligibility Field</b> field.</p>	<p>Yes (Conditional)</p> <p><b>Note:</b> This field is required when you are specifying a domestic provider eligibility rule type in a level funded pricing rule type.</p>

2. Enter the required details in the **Level Funded - Specific Additional Data** section.
3. Click **Save**.

The level funded-specific data is added in the level funded pricing rule type.

### **Related Topics**

For more information on...	See...
How to define a level funded pricing rule type	<a href="#">Defining a Level Funded Pricing Rule Type</a> on page 2644
How to edit a level funded pricing rule type	<a href="#">Editing a Level Funded Pricing Rule Type</a> on page 2658

## **Editing a Level Funded Pricing Rule Type**

### **Prerequisites**

To edit a level funded pricing rule type, you should have:

- Level funded pricing rule type business object defined in the application.
- Level funded pricing rule business object defined in the application.

### **Procedure**

To edit a level funded pricing rule type:

1. Click the **Admin** link in the **Application** toolbar.  
A list appears.
2. From the **Admin** menu, select **P** and then click **Pricing Rule Type**.  
A sub-menu appears.
3. Click the **Search** option from the **Pricing Rule Type** sub-menu.  
The **Pricing Rule Type** screen appears.
4. In the **Pricing Rule Type List** zone, click the **Edit** (✎) icon in the **Edit** column corresponding to the pricing rule type whose details you want to edit.

The **Level Funded Pricing Rule Type** screen appears. It contains the following sections:

- **Main** – Used to specify basic details about the discount arrangement pricing rule type.
- **Algorithms** – Used to associate the algorithms with a discount arrangement pricing rule type.
- **Additional Data** – Used to specify the additional information about the discount arrangement pricing rule type.
- **Price Items** – Used to add the price items for which you can define the discount arrangement pricing rules using the discount arrangement pricing rule type.
- **Price Item Parameters** – Used to add the price item parameters based on which you want to define the price item pricing.
- **Characteristics** – Used to define characteristics for a discount arrangement pricing rule type.
- **Level Funded - Specific Additional Data** – Used to define the discount arrangement - specific additional data in a discount arrangement pricing rule type.

The **Main** section contains the following fields:

<b>Field Name</b>	<b>Field Description</b>	<b>Mandatory (Yes or No)</b>
Pricing Rule Type	Displays the level funded pricing rule type.	Not applicable
Description	Used to specify the description for the level funded pricing rule type.	Yes
Detailed Description	Used to specify additional information about the level funded pricing rule type.	No
Pricing Rule Business Object	Used to indicate the business object using which you want to create the level funded pricing rule. The valid value is: <ul style="list-style-type: none"> <li>• Level Funded (LF) Pricing Rule</li> </ul>	Yes
Business Object	Indicates the business object used while defining the level funded pricing rule type.	Not applicable

Field Name	Field Description	Mandatory (Yes or No)
Status	Used to indicate the status of the level funded pricing rule type. The valid values are: <ul style="list-style-type: none"> <li>Active</li> <li>Inactive</li> </ul>	Yes
Primary	Used to indicate whether the pricing rule type is primary. <b>Note:</b> You must not select the <b>Primary</b> option while defining the level funded pricing rule type.	Not applicable
Pricing Rule Type Category	Indicates the pricing rule type category for the level funded pricing rule type. The valid values are: <ul style="list-style-type: none"> <li>Level Funded</li> </ul>	No

**Tip:** Alternatively, you can edit the details of a level funded pricing rule type by clicking the **Edit** button in the **Pricing Rule Type** zone.

- Modify the details in the **Main** section.
- Associate the following algorithms with the level funded pricing rule type:

System Event	Algorithm	Algorithm Type	Description
Account and Price Item Derivation	C1_ACCPRIS	C1_ACCPRID	Account and Priceitem Derivation For Level Funded
Accumulation Post Processing	C1-LFACPOST	C1-LFACPOST	Level Funded Accumulation Post Processing

- Modify the additional data for a level funded pricing rule type, if required.
- Add, edit, or remove the required price items in the level funded pricing rule type.
- Add, edit, or remove the price item parameters in the level funded pricing rule type, if required.
- Add, edit, or remove characteristics for a level funded pricing rule type, if required.
- Modify the level funded-specific additional data in the level funded pricing rule type, if required.
- Click **Save**.

The changes made to the level funded pricing rule type are saved.

### **Related Topics**

For more information on...	See...
How to associate algorithms with the level funded pricing rule type	<a href="#">Associating an Algorithm with a Level Funded Pricing Rule Type</a> on page 2646
How to define additional data for a level funded pricing rule type	<a href="#">Defining Additional Data in a Level Funded Pricing Rule Type</a> on page 2647
How to add price items in the level funded pricing rule type	<a href="#">Adding a Price Item in a Level Funded Pricing Rule Type</a> on page 2649

For more information on...	See...
How to add price item parameters in the level funded pricing rule type	<a href="#">Adding a Price Item Parameter in a Level Funded Pricing Rule Type</a> on page 2652
How to define characteristics for a level funded pricing rule type	<a href="#">Defining Characteristics for a Level Funded Pricing Rule Type</a> on page 2653
How to define level funded-specific data in the level funded pricing rule type	<a href="#">Defining the Level Funded Specific Additional Data in a Level Funded Pricing Rule Type</a> on page 2654

## Deleting a Level Funded Pricing Rule Type

### Procedure

To delete a level funded pricing rule type:

1. Click the **Admin** link in the **Application** toolbar.  
A list appears.
2. From the **Admin** menu, select **P** and then click **Pricing Rule Type**.  
A sub-menu appears.
3. Click the **Search** option from the **Pricing Rule Type** sub-menu.  
The **Pricing Rule Type** screen appears.
4. In the **Pricing Rule Type List** zone, click the **Delete** (🗑️) icon in the **Delete** column corresponding to the level funded pricing rule type that you want to delete.  
A message appears confirming whether you want to delete the level funded pricing rule type.

**Note:** You can delete a level funded pricing rule type only when it is not yet used in the system.

**Tip:** Alternatively, you can delete a level funded pricing rule type by clicking the **Delete** button in the **Pricing Rule Type** zone.

5. Click **OK**.  
The level funded pricing rule type is deleted.

### Related Topics

For more information on...	See...
<b>Pricing Rule Type</b> screen	<a href="#">Pricing Rule Type</a> on page 2343
<b>Pricing Rule Type List</b> zone	<a href="#">Pricing Rule Type List</a> on page 2344
<b>Pricing Rule Type</b> zone	<a href="#">Pricing Rule Type</a> on page 2347

## Viewing the Level Funded Pricing Rule Type Details

### Procedure

To view the details of a level funded pricing rule type:

1. Click the **Admin** link in the **Application** toolbar.  
A list appears.
2. From the **Admin** menu, select **P** and then click **Pricing Rule Type**.  
A sub-menu appears.

- Click the **Search** option from the **Pricing Rule Type** sub-menu.  
The **Pricing Rule Type** screen appears.
- In the **Pricing Rule Type List** zone, click the **Broadcast**  icon corresponding to the level funded pricing rule type whose details you want to view.  
The **Pricing Rule Type** zone appears.
- View the details of the level funded pricing rule type in the **Pricing Rule Type** zone.

### Related Topics

For more information on...	See...
<b>Pricing Rule Type</b> screen	<a href="#">Pricing Rule Type</a> on page 2343
<b>Pricing Rule Type List</b> zone	<a href="#">Pricing Rule Type List</a> on page 2344
<b>Pricing Rule Type</b> zone	<a href="#">Pricing Rule Type</a> on page 2347

## Defining a Level Funded Pricing Rule for a Parent Customer

### Prerequisites

To define a level funded pricing rule for a parent customer, you should have:

- Pricing rule type where the category is set to **Level Funded**.
- Price items associated with the level funded pricing rule type.
- Specific stop-loss pricing rule of the parent customer, whose accumulation parameters you want to inherit for level-funding.

### Procedure

To define a level funded pricing rule for a parent customer:

- Search for a parent customer in the **Customer 360° View** screen.
- In the **Search Results** section, click the **View**  icon corresponding to the parent customer whose pricing details you want to view.  
The **Person** tab appears in the **Customer 360° Information** screen.
- Click the **Pricing** tab.  
The **Pricing** tab appears.
- Click the **Add** link in the upper-right corner of the **Parent Customer Pricing Rules** zone.  
The **Pricing Rule** screen appears. It contains the following fields:

Field Name	Field Description	Mandatory (Yes or No)
Person Name	Indicates the parent customer for whom you want to create a level funded pricing rule type.	Not applicable
Person Type	Indicates the type of the parent customer. The valid value is: <ul style="list-style-type: none"> <li><b>Parent Customer</b></li> </ul>	Not applicable
Pricing Rule Type	Used to indicate the pricing rule type using which you want to create a level funded pricing rule.	Yes

- Select the required pricing rule type in the respective field.

6. Click **OK**.

The **Level Funded (LF) Pricing Rule** screen appears. It contains the following sections:

- **Customer Information** – Displays the information about the parent customer for whom you are defining the level funded pricing rule. It contains the following fields:

Field Name	Field Description
Parent Customer Information	Indicates the parent customer for whom you are defining the level funded pricing rule.
Pricing Rule Type	Indicates the pricing rule type using which you are defining the level funded pricing rule.

- **Main** – Used to specify basic details in the level funding pricing rule.
- **Accumulation Parameters** – Used to define the accumulation parameters in a level funded pricing rule.
- **Final Settlement Rules** – Used to define the final settlement rules when the customer decides to renew or cancel the level-funded agreement.
- **Characteristics** – Used to define characteristics for the level funded pricing rule.

**Note:**

The **Accumulation Parameters** and **Final Settlement Rules** section appear only when you specify a price item in the **Main** section.

The **Main** section contains the following fields:

Field Name	Field Description	Mandatory (Yes or No)
Price Item	Used to indicate the price item for which you want to define the level funded pricing rule.	Yes
Parent Customer's Pricing Rule	Used to indicate the date range of each specific stop-loss pricing rule, defined for the parent customer.  <b>Note:</b> On selecting the specific stop-loss pricing rule of the parent customer, the level funded <b>Pricing Start Date</b> and <b>Pricing End Date</b> field is set automatically.	Yes
Pricing Start Date	Used to specify the date from when the level funded pricing rule is effective.  <b>Note:</b> The pricing start date cannot be later than the pricing end date.	Yes
Pricing End Date	Used to specify the date till when the level funded pricing rule is effective.  <b>Note:</b> The pricing end date cannot be earlier than the pricing start date.	No
Rate Option	Used to indicate the rate option that you want to use while defining the pricing for the price item.	Yes

Field Name	Field Description	Mandatory (Yes or No)
Settlement Frequency	<p>Used to indicate the settlement frequency which helps to determine the bill after date. The valid values are:</p> <ul style="list-style-type: none"> <li>• <b>Immediately</b> - If you select this option from the list, the bill after date is not calculated. The level-funded settlement billable charge is billed immediately in the next bill cycle.</li> <li>• <b>Manually (At Regular Intervals)</b> - If you select this option from the list, the bill after date which is specified in the <b>Manual Settlement Bill After Date</b> parameter while executing the <b>C1-BCLF</b> batch is stamped on the level-funded settlement billable charge.</li> <li>• <b>Monthly</b> - If you select this option from the list, the bill after date is set to the last day of the month.</li> <li>• <b>On Settlement</b> - If you select this option from the list, the bill after date is set to the settlement date in the level-funded settlement billable charge.</li> <li>• <b>Yearly</b> - If you select this option from the list, the bill after date in the credit billable charge is set to the pricing end date in the level-funded settlement billable charge.</li> </ul>	Yes
Underwriter Review	<p>Used to indicate whether the underwriter settlement review flag is on or off. The valid values are:</p> <ul style="list-style-type: none"> <li>• Yes</li> <li>• No</li> </ul> <p><b>Note:</b> By default the value of this option type is set to <b>Yes</b>.</p>	No

7. Enter the required details in the **Main** section.
8. Define the accumulation parameters in the level funded pricing rule.
9. Define the final settlement rules in the level funded pricing rule.
10. Define characteristics for the level funded pricing rule, if required.
11. Click **Save**.

The level funded pricing rule is defined for the parent customer.

#### **Related Topics**

For more information on...	See...
How to search for a parent customer	<a href="#">Searching for a Person</a> on page 185
<b>Parent Customer Pricing Rules</b> zone	<a href="#">Parent Customer Pricing Rules</a> on page 231
How to define the accumulation parameters in a level funded pricing rule	<a href="#">Defining Accumulation Parameters in a Level Funded Pricing Rule</a> on page 2665
How to define the final settlement rules in a level funded pricing rule	<a href="#">Defining the Final Settlement Rules in a Level Funded Pricing Rule</a> on page 2666



For more information on...	See...
How to define the characteristics for a level funded pricing rule	<a href="#">Defining a Characteristic for a Level Funded Pricing Rule</a> on page 2671

## Defining Accumulation Parameters in a Level Funded Pricing Rule

### Procedure

To define accumulation parameters in a level funding pricing rule:

1. Ensure that the **Accumulation Parameters** section is expanded only when you have selected an option from the **Price Item** field of the **Main** section while defining a level funded pricing rule.

The **Accumulation Parameters** section contains the following fields:

Field Name	Field Description	Mandatory (Yes or No)
Accumulation Group ID	Displays a blank field. An accumulation group ID is generated when accumulation parameter values are defined for a level funded pricing rule.  <b>Note:</b> It is a read-only field.	Not applicable
Settlement Account ID	Used to indicate the account ID to whom the settlement amount is credited.	Yes
Incurred Start Date	Displays the incurred start date (inherited from parent customer's specific stop-loss pricing rule) based on which you want to accumulate the level funded pricing.  <b>Note:</b> It is a read-only field.	Not applicable
Incurred End Date	Displays the incurred end date (inherited from parent customer's specific stop-loss pricing rule) based on which you want to accumulate the level funded pricing.  <b>Note:</b> It is a read-only field.	Not applicable
Paid Start Date	Displays the paid start date (inherited from parent customer's specific stop-loss pricing rule) based on which you want to accumulate the level funded pricing.  <b>Note:</b> It is a read-only field.	Not applicable
Paid End Date	Displays the paid end date (inherited from parent customer's specific stop-loss pricing rule) based on which you want to accumulate the level funded pricing.  <b>Note:</b> It is a read-only field.	Not applicable

Field Name	Field Description	Mandatory (Yes or No)
Settlement Days	<p>Used to indicate the number of days as the settlement days which help in calculating the settlement date. The valid values are:</p> <ul style="list-style-type: none"> <li>• 30 Days</li> <li>• 60 Days</li> <li>• 90 Days</li> <li>• 120 Days</li> <li>• 150 Days</li> <li>• 180 Days</li> </ul> <p><b>Note:</b> Settlement date is calculated as the pricing end date, incurred end date, or paid end date whichever is later plus the settlement days.</p>	Not applicable

2. Enter the required details in the **Accumulation Parameters** section.
3. Click **Save**.

The accumulation parameters are defined in the level funded pricing rule.

#### Related Topics

For more information on...	See...
How to define a level funded pricing rule for a parent customer	<a href="#">Defining a Level Funded Pricing Rule for a Parent Customer</a> on page 2662
How to edit a level funded pricing rule of a parent customer	<a href="#">Editing a Level Funded Pricing Rule of a Parent Customer</a>

## Defining the Final Settlement Rules in a Level Funded Pricing Rule

### Procedure

To define the final settlement rules in a level funded pricing rule:

1. Ensure that the **Final Settlement Rules** section is expanded when you are defining or editing a level funded pricing rule type.

The **Final Settlement Rules** section contains the following sub-sections:

- **Customer Renews** - Used to define the final settlement rules when the customer renews the contract.
- **Customer Cancels** - Used to define the final settlement rules when the customer cancels the contract.
- **Renewal Decision** - Used to indicate the status for the upcoming level funded contract.

The **Customer Renews** sub-section contains the following fields:

<b>Field Name</b>	<b>Field Description</b>	<b>Mandatory (Yes or No)</b>									
Final Settlement Mode	Displays the final settlement mode when the customer renews the level funded agreement. The valid values are: <ul style="list-style-type: none"> <li>Final Settlement Surplus</li> <li>Final Settlement Deficit</li> </ul>	Not applicable									
Final Settlement Option	Used to indicate the final settlement option when the customer renews the level funded agreement. <table border="1" data-bbox="480 512 1260 825"> <thead> <tr> <th><b>Field Name</b></th> <th><b>Field Description</b></th> <th><b>Mandatory (Yes or No)</b></th> </tr> </thead> <tbody> <tr> <td>Final Settlement Surplus</td> <td>Used to indicate the final settlement option in case of surplus.</td> <td>Yes</td> </tr> <tr> <td>Final Settlement Deficit</td> <td>Used to indicate the final settlement option in case of deficit.</td> <td>Yes</td> </tr> </tbody> </table>	<b>Field Name</b>	<b>Field Description</b>	<b>Mandatory (Yes or No)</b>	Final Settlement Surplus	Used to indicate the final settlement option in case of surplus.	Yes	Final Settlement Deficit	Used to indicate the final settlement option in case of deficit.	Yes	Not applicable
<b>Field Name</b>	<b>Field Description</b>	<b>Mandatory (Yes or No)</b>									
Final Settlement Surplus	Used to indicate the final settlement option in case of surplus.	Yes									
Final Settlement Deficit	Used to indicate the final settlement option in case of deficit.	Yes									
Flat/ Percentage	Used to indicate the final settlement payment type when the customer renews the level funded agreement. <table border="1" data-bbox="480 940 1260 1457"> <thead> <tr> <th><b>Field Name</b></th> <th><b>Field Description</b></th> <th><b>Mandatory (Yes or No)</b></th> </tr> </thead> <tbody> <tr> <td>Final Settlement Surplus</td> <td>Used to indicate the payment type in case of surplus. The valid values are: <ul style="list-style-type: none"> <li>Flat Dollar</li> <li>Percentage</li> </ul> </td> <td>Yes</td> </tr> <tr> <td>Final Settlement Deficit</td> <td>Used to indicate the payment type in case of deficit. The valid values are: <ul style="list-style-type: none"> <li>Flat Dollar</li> <li>Percentage</li> </ul> </td> <td>Yes</td> </tr> </tbody> </table>	<b>Field Name</b>	<b>Field Description</b>	<b>Mandatory (Yes or No)</b>	Final Settlement Surplus	Used to indicate the payment type in case of surplus. The valid values are: <ul style="list-style-type: none"> <li>Flat Dollar</li> <li>Percentage</li> </ul>	Yes	Final Settlement Deficit	Used to indicate the payment type in case of deficit. The valid values are: <ul style="list-style-type: none"> <li>Flat Dollar</li> <li>Percentage</li> </ul>	Yes	Not applicable
<b>Field Name</b>	<b>Field Description</b>	<b>Mandatory (Yes or No)</b>									
Final Settlement Surplus	Used to indicate the payment type in case of surplus. The valid values are: <ul style="list-style-type: none"> <li>Flat Dollar</li> <li>Percentage</li> </ul>	Yes									
Final Settlement Deficit	Used to indicate the payment type in case of deficit. The valid values are: <ul style="list-style-type: none"> <li>Flat Dollar</li> <li>Percentage</li> </ul>	Yes									

Field Name	Field Description	Mandatory (Yes or No)									
Percentage Retained	Used to specify the percentage retained by the ASO provider when the customer renews the level funded agreement.	Not applicable									
	<table border="1"> <thead> <tr> <th>Field Name</th> <th>Field Description</th> <th>Mandatory (Yes or No)</th> </tr> </thead> <tbody> <tr> <td>Final Settlement Surplus</td> <td>Used to specify the percentage of surplus that should be retained by the ASO provider. <b>Note:</b> This field appears when the <b>Flat/Percentage</b> field is <b>Percentage</b>.</td> <td>Yes (Conditional)</td> </tr> <tr> <td>Final Settlement Deficit</td> <td>Used to specify the percentage of deficit that should be offered as a discount by the ASO provider. <b>Note:</b> This field appears when the <b>Flat/Percentage</b> field is <b>Percentage</b>.</td> <td>Yes (Conditional)</td> </tr> </tbody> </table>		Field Name	Field Description	Mandatory (Yes or No)	Final Settlement Surplus	Used to specify the percentage of surplus that should be retained by the ASO provider. <b>Note:</b> This field appears when the <b>Flat/Percentage</b> field is <b>Percentage</b> .	Yes (Conditional)	Final Settlement Deficit	Used to specify the percentage of deficit that should be offered as a discount by the ASO provider. <b>Note:</b> This field appears when the <b>Flat/Percentage</b> field is <b>Percentage</b> .	Yes (Conditional)
	Field Name		Field Description	Mandatory (Yes or No)							
Final Settlement Surplus	Used to specify the percentage of surplus that should be retained by the ASO provider. <b>Note:</b> This field appears when the <b>Flat/Percentage</b> field is <b>Percentage</b> .	Yes (Conditional)									
Final Settlement Deficit	Used to specify the percentage of deficit that should be offered as a discount by the ASO provider. <b>Note:</b> This field appears when the <b>Flat/Percentage</b> field is <b>Percentage</b> .	Yes (Conditional)									
Final Settlement Deficit	Used to specify the percentage of deficit that should be offered as a discount by the ASO provider. <b>Note:</b> This field appears when the <b>Flat/Percentage</b> field is <b>Percentage</b> .	Yes (Conditional)									
Flat Effective Payout	Used to specify the actual amount which should be retained by the ASO provider or offered as a discount, when the customer renews the level funded agreement.	Not applicable									
	<table border="1"> <thead> <tr> <th>Field Name</th> <th>Field Description</th> <th>Mandatory (Yes or No)</th> </tr> </thead> <tbody> <tr> <td>Final Settlement Surplus</td> <td>Used to specify the actual amount of surplus that should be retained by the ASO provider. <b>Note:</b> This field appears when the <b>Flat/Percentage</b> field is <b>Flat Dollar</b>.</td> <td>Yes (Conditional)</td> </tr> <tr> <td>Final Settlement Deficit</td> <td>Used to specify the actual amount of deficit that should be offered as a discount by the ASO provider. <b>Note:</b> This field appears when the <b>Flat/Percentage</b> field is <b>Flat Dollar</b>.</td> <td>Yes (Conditional)</td> </tr> </tbody> </table>		Field Name	Field Description	Mandatory (Yes or No)	Final Settlement Surplus	Used to specify the actual amount of surplus that should be retained by the ASO provider. <b>Note:</b> This field appears when the <b>Flat/Percentage</b> field is <b>Flat Dollar</b> .	Yes (Conditional)	Final Settlement Deficit	Used to specify the actual amount of deficit that should be offered as a discount by the ASO provider. <b>Note:</b> This field appears when the <b>Flat/Percentage</b> field is <b>Flat Dollar</b> .	Yes (Conditional)
	Field Name		Field Description	Mandatory (Yes or No)							
Final Settlement Surplus	Used to specify the actual amount of surplus that should be retained by the ASO provider. <b>Note:</b> This field appears when the <b>Flat/Percentage</b> field is <b>Flat Dollar</b> .	Yes (Conditional)									
Final Settlement Deficit	Used to specify the actual amount of deficit that should be offered as a discount by the ASO provider. <b>Note:</b> This field appears when the <b>Flat/Percentage</b> field is <b>Flat Dollar</b> .	Yes (Conditional)									
Final Settlement Deficit	Used to specify the actual amount of deficit that should be offered as a discount by the ASO provider. <b>Note:</b> This field appears when the <b>Flat/Percentage</b> field is <b>Flat Dollar</b> .	Yes (Conditional)									

The **Customer Cancels** sub-section contains the following fields:

<b>Field Name</b>	<b>Field Description</b>	<b>Mandatory (Yes or No)</b>									
Final Settlement Mode	Displays final settlement mode when the customer cancels the level funded agreement. The valid values are: <ul style="list-style-type: none"> <li>Final Settlement Surplus</li> <li>Final Settlement Deficit</li> </ul>	Not applicable									
Final Settlement Option	Used to indicate the final settlement option when the customer cancels the level funded agreement. <table border="1" data-bbox="483 512 1260 825"> <thead> <tr> <th><b>Field Name</b></th> <th><b>Field Description</b></th> <th><b>Mandatory (Yes or No)</b></th> </tr> </thead> <tbody> <tr> <td>Final Settlement Surplus</td> <td>Used to indicate the final settlement option in case of surplus.</td> <td>Yes</td> </tr> <tr> <td>Final Settlement Deficit</td> <td>Used to indicate the final settlement option in case of deficit.</td> <td>Yes</td> </tr> </tbody> </table>	<b>Field Name</b>	<b>Field Description</b>	<b>Mandatory (Yes or No)</b>	Final Settlement Surplus	Used to indicate the final settlement option in case of surplus.	Yes	Final Settlement Deficit	Used to indicate the final settlement option in case of deficit.	Yes	Not applicable
<b>Field Name</b>	<b>Field Description</b>	<b>Mandatory (Yes or No)</b>									
Final Settlement Surplus	Used to indicate the final settlement option in case of surplus.	Yes									
Final Settlement Deficit	Used to indicate the final settlement option in case of deficit.	Yes									
Flat/ Percentage	Used to indicate the final settlement payment type when the customer cancels the level funded agreement. <table border="1" data-bbox="483 940 1260 1457"> <thead> <tr> <th><b>Field Name</b></th> <th><b>Field Description</b></th> <th><b>Mandatory (Yes or No)</b></th> </tr> </thead> <tbody> <tr> <td>Final Settlement Surplus</td> <td>Used to indicate the payment type in case of surplus. The valid values are: <ul style="list-style-type: none"> <li>Flat Dollar</li> <li>Percentage</li> </ul> </td> <td>Yes</td> </tr> <tr> <td>Final Settlement Deficit</td> <td>Used to indicate the payment type in case of deficit. The valid values are: <ul style="list-style-type: none"> <li>Flat Dollar</li> <li>Percentage</li> </ul> </td> <td>Yes</td> </tr> </tbody> </table>	<b>Field Name</b>	<b>Field Description</b>	<b>Mandatory (Yes or No)</b>	Final Settlement Surplus	Used to indicate the payment type in case of surplus. The valid values are: <ul style="list-style-type: none"> <li>Flat Dollar</li> <li>Percentage</li> </ul>	Yes	Final Settlement Deficit	Used to indicate the payment type in case of deficit. The valid values are: <ul style="list-style-type: none"> <li>Flat Dollar</li> <li>Percentage</li> </ul>	Yes	Not applicable
<b>Field Name</b>	<b>Field Description</b>	<b>Mandatory (Yes or No)</b>									
Final Settlement Surplus	Used to indicate the payment type in case of surplus. The valid values are: <ul style="list-style-type: none"> <li>Flat Dollar</li> <li>Percentage</li> </ul>	Yes									
Final Settlement Deficit	Used to indicate the payment type in case of deficit. The valid values are: <ul style="list-style-type: none"> <li>Flat Dollar</li> <li>Percentage</li> </ul>	Yes									

Field Name	Field Description	Mandatory (Yes or No)						
Percentage Retained	Used to specify the percentage retained by the ASO provider when the customer cancels the level funded agreement.	Not applicable						
	<table border="1"> <thead> <tr> <th data-bbox="475 325 678 409">Field Name</th> <th data-bbox="678 325 1052 409">Field Description</th> <th data-bbox="1052 325 1260 409">Mandatory (Yes or No)</th> </tr> </thead> <tbody> <tr> <td data-bbox="475 409 678 655">Final Settlement Surplus</td> <td data-bbox="678 409 1052 655">Used to specify the percentage of surplus that should be retained by the ASO provider. <b>Note:</b> This field appears when the <b>Flat/Percentage</b> field is <b>Percentage</b>.</td> <td data-bbox="1052 409 1260 655">Yes</td> </tr> </tbody> </table>		Field Name	Field Description	Mandatory (Yes or No)	Final Settlement Surplus	Used to specify the percentage of surplus that should be retained by the ASO provider. <b>Note:</b> This field appears when the <b>Flat/Percentage</b> field is <b>Percentage</b> .	Yes
	Field Name		Field Description	Mandatory (Yes or No)				
Final Settlement Surplus	Used to specify the percentage of surplus that should be retained by the ASO provider. <b>Note:</b> This field appears when the <b>Flat/Percentage</b> field is <b>Percentage</b> .	Yes						
Final Settlement Deficit	Used to specify the percentage of deficit that should be offered as a discount by the ASO provider. <b>Note:</b> This field appears when the <b>Flat/Percentage</b> field is <b>Percentage</b> .	Yes						
Flat Effective Payout	Used to specify the actual amount which should be retained by the ASO provider or offered as a discount, when the customer cancels the level funded agreement.	Not applicable						
	<table border="1"> <thead> <tr> <th data-bbox="475 1102 678 1186">Field Name</th> <th data-bbox="678 1102 1052 1186">Field Description</th> <th data-bbox="1052 1102 1260 1186">Mandatory (Yes or No)</th> </tr> </thead> <tbody> <tr> <td data-bbox="475 1186 678 1432">Final Settlement Surplus</td> <td data-bbox="678 1186 1052 1432">Used to specify the actual amount of surplus that should be retained by the ASO provider. <b>Note:</b> This field appears when the <b>Flat/Percentage</b> field is <b>Flat Dollar</b>.</td> <td data-bbox="1052 1186 1260 1432">Yes</td> </tr> </tbody> </table>		Field Name	Field Description	Mandatory (Yes or No)	Final Settlement Surplus	Used to specify the actual amount of surplus that should be retained by the ASO provider. <b>Note:</b> This field appears when the <b>Flat/Percentage</b> field is <b>Flat Dollar</b> .	Yes
	Field Name		Field Description	Mandatory (Yes or No)				
Final Settlement Surplus	Used to specify the actual amount of surplus that should be retained by the ASO provider. <b>Note:</b> This field appears when the <b>Flat/Percentage</b> field is <b>Flat Dollar</b> .	Yes						
Final Settlement Deficit	Used to specify the actual amount of deficit that should be offered as a discount by the ASO provider. <b>Note:</b> This field appears when the <b>Flat/Percentage</b> field is <b>Flat Dollar</b> .	Yes						

The **Renewal Decision** sub-section contains the following fields:

Field Name	Field Description	Mandatory (Yes or No)
Renewal Decision	Used to indicate the upcoming status of the level funded contract. The valid values are: <ul style="list-style-type: none"> <li>Cancelled</li> <li>Renewed</li> </ul> <div style="border: 1px solid black; padding: 5px; margin-top: 10px;"> <p><b>Note:</b> This field appears only when the level funded current contract date is exceeded.</p> </div>	No

- Enter the required details in the **Final Settlement Rules** section.
- Click **Save**.

The final settlement rules are added in the level funded pricing rule.

### Related Topics

For more information on...	See...
How to define a level funded pricing rule for a parent customer	<a href="#">Defining a Level Funded Pricing Rule for a Parent Customer</a> on page 2662
How to edit a level funded pricing rule of a parent customer	<a href="#">Editing a Level Funded Pricing Rule of a Parent Customer</a>

## Defining a Characteristic for a Level Funded Pricing Rule

### Prerequisites

To define a characteristic for a level funded pricing rule, you should have:

- Characteristic types defined in the application (where the characteristic entity is set to **Pricing Rule**).

### Procedure

To define a characteristic for a level funded pricing rule:

- Ensure that the **Characteristics** section is expanded when you are defining or editing a level funded pricing rule.

The **Characteristics** section contains the following fields in the grid:

Column Name	Column Description	Mandatory (Yes or No)
Effective Date	Used to specify the date from when the characteristic is effective for a level funded pricing rule.	Yes (Conditional) <div style="border: 1px solid black; padding: 5px; margin-top: 10px;"> <p><b>Note:</b> This field is required when you are defining a characteristic for a level funded pricing rule.</p> </div>

Column Name	Column Description	Mandatory (Yes or No)
Characteristic Type	Used to indicate the characteristic type.  <b>Note:</b> The list includes only those characteristic types where the characteristic entity is set to <b>Pricing Rule</b> .	Yes (Conditional)  <b>Note:</b> This field is required when you are defining a characteristic for a level funded pricing rule.
Characteristic Value	Used to specify the value for the characteristic type.  <b>Note:</b> If you select a predefined characteristic type, the <b>Search</b>  icon appears corresponding to the <b>Characteristic Value</b> field. On clicking the <b>Search</b> icon, the <b>Predefined Characteristic Search</b> window appears.  On specifying the value for a predefined characteristic type, the description of the characteristic value appears corresponding to the <b>Characteristic Value</b> field.	Yes (Conditional)  <b>Note:</b> This field is required when you are defining a characteristic for a level funded pricing rule.

- Enter the required details in the **Characteristics** section.
- If you want to define more than one characteristic for the level funded pricing rule, click the **Add**  icon and then repeat step 2.

**Note:** However, if you want to remove a characteristic from the level funded pricing rule, click the **Delete**  icon corresponding to the characteristic.

- Click **Save**.

The characteristics are defined for the level funded pricing rule.

### Related Topics

For more information on...	See...
How to define a level funded pricing rule for a parent customer	<a href="#">Defining a Level Funded Pricing Rule for a Parent Customer</a> on page 2662
How to edit a level funded pricing rule of a parent customer	<a href="#">Editing a Level Funded Pricing Rule of a Parent Customer</a>
How to define a level funded pricing rule for a bill group	<a href="#">Defining a Level Funded Pricing Rule for a Bill Group</a> on page 2672
How to edit a level funded pricing rule for a bill group	<a href="#">Editing a Level Funded Pricing Rule of a Bill Group</a>

## Defining a Level Funded Pricing Rule for a Bill Group

### Prerequisites

To define a level funded pricing rule for a bill group, you should have:

- Pricing rule type where the category is set to **Level Funded**.



- Price items associated with the level funded pricing rule type.
- Specific stop-loss pricing rule of the parent customer, whose accumulation parameters you want to inherit for level-funding.
- Policy status defined in the application.

### **Procedure**

To define a level funded pricing rule for a bill group:

1. Search for the Administrative Services Only (ASO) person, whose person type is set to **Bill Group**, in the **Customer 360° View** screen.
2. In the **Search Results** section, click the **View** () icon corresponding to the person whose pricing details you want to view.

The **Person** tab appears in the **Customer 360° Information** screen.

3. Click the **Pricing** tab.

The **Pricing** tab appears.

4. Click the **Broadcast** () icon in the **Bill Group ASO Policy Information** zone, corresponding to the **Bill Group Information** column, whose bill group details you want to view.

The **Bill Group ASO Policy Pricing Rules** zone is displayed.

5. Click the **Add** link in the upper right corner of the **Bill Group ASO Policy Pricing Rules** zone.

The **Pricing Rule** screen appears. It contains the following fields:

<b>Field Name</b>	<b>Field Description</b>	<b>Mandatory (Yes or No)</b>
Person Name	Indicates the name of the parent customer.	Not applicable
Person Type	Indicates the type of the parent customer.  <b>Note:</b> If you are defining the pricing rule type for the parent customer, then the person type will be <b>Parent Customer</b> .	Not applicable
Pricing Rule Type	Used to indicate the pricing rule type using which you want to create a level funded pricing rule.  <b>Note:</b> Select the <b>Level Funded Pricing Rule Type</b> option, as the pricing rule.	Yes  <b>Note:</b> If the pricing rule type is not selected then the application displays an error message.
Pricing Group	Used to indicate the pricing group which is used while defining the pricing.	No
Policy Status	Used to indicate the policy status for the pricing rule. The valid values are: <ul style="list-style-type: none"> <li>• In Force/Active</li> <li>• Runout</li> </ul>	Yes (Conditional)  <b>Note:</b> Policy Status is required once the Pricing Rule Type is selected.

6. Click **OK**.

The **Level Funded (LF) Pricing Rule** screen appears. It contains the following sections:

- **Customer Information** – Displays the information about the bill group. It contains the following columns:

Column Name	Column Description
Bill Group Information	Displays the bill group information.
Policy Start Date	Displays the date from when the policy is effective.
Policy End Date	Displays the date till when the policy is effective.
Policy Status	Indicates the policy status for the pricing rule.
Pricing Rule Type	Indicates the pricing rule type for whom the level funded pricing rule is created.

- **Main** – Used to specify basic details in the level funding pricing rule.
- **Accumulation Criteria** – Used to define the accumulation criteria in a level funded pricing rule.
- **Pricing Information for rule type category : Claim** – Used to define the line items in a particular claim pricing rule or those which are associated with the level funded rule type category.
- **Pricing Information for rule type category : Ancillary** – Used to define the line items in a particular ancillary pricing rule or those which are associated with the level funded rule type category.
- **Pricing Information for rule type category : Discount** – Used to define the discount arrangement pricing rule which is effective for level-funding calculations.
- **Pricing Information for rule type category : Retention** – Used to define the retention pricing rule which is effective for level-funding calculations.
- **Characteristics** – Used to define characteristics for the level funded pricing rule.

<p><b>Note:</b></p> <p>The <b>Accumulation Criteria, Pricing Information for rule type category: Claim, Pricing Information for rule type category: Ancillary, Pricing Information for rule type category: Discount, and Pricing Information for rule type category: Retention</b> section appear only when you specify a price item in the <b>Main</b> section.</p>
--

The **Main** section contains the following fields:

Field Name	Field Description	Mandatory (Yes or No)
Price Item	Used to indicate the price item for which you want to define the level funded pricing rule.	Yes
Parent Customer's Pricing Rule	Used to indicate the date range of each specific stop-loss pricing rule, defined for the parent customer.  <b>Note:</b> On selecting the specific stop-loss pricing rule of the parent customer, the level funded <b>Pricing Start Date</b> and <b>Pricing End Date</b> field is set automatically.	Yes
Pricing Start Date	Used to specify the date from when the level funded pricing rule is effective.  <b>Note:</b> The pricing start date cannot be later than the pricing end date.	Not applicable

Field Name	Field Description	Mandatory (Yes or No)
Pricing End Date	Used to specify the date till when the level funded pricing rule is effective.  <b>Note:</b> The pricing end date cannot be earlier than the pricing start date.	Not applicable
Rate Option	Used to indicate the rate option that you want to use while defining the pricing for the price item.	Yes
Settlement Fund Price Item	Used to indicate the price item derived from the level funded pricing rule type, used to create the level funded pricing rule type.	Not applicable

7. Enter the required details in the **Main** section.
8. Define the accumulation criteria in the level funded pricing rule for a bill group.
9. Define the pricing information for the claim rule type category for a bill group.
10. Define the pricing information for the ancillary rule type category for a bill group, if required.
11. Define the pricing information for the discount rule type category for a bill group, if required.
12. Define the pricing information for the retention rule type category for a bill group, if required.
13. Define characteristics for the level funded pricing rule for a bill group, if required, if required.
14. Click **Save**.

The level funded pricing rule is defined for a bill group.

### **Related Topics**

For more information on...	See...
How to search for a parent customer	<a href="#">Searching for a Person</a> on page 185
<b>Parent Customer Pricing Rules</b> zone	<a href="#">Parent Customer Pricing Rules</a> on page 231
How to define accumulation criteria in a level funded rule for a bill group	<a href="#">Defining Accumulation Criteria in a Level Funded Pricing Rule</a> on page 2675
How to define claim pricing information in a level funded pricing rule	<a href="#">Defining Claim Pricing Information in a Level Funded Pricing Rule</a> on page 2678
How to define ancillary pricing information in a level funded pricing rule	<a href="#">Defining Ancillary Pricing Information in a Level Funded Pricing Rule</a> on page 2681
How to define discount pricing information in a level funded pricing rule	<a href="#">Defining Discount Arrangement Pricing Information in a Level Funded Pricing Rule</a> on page 2684
How to define retention type claim based and/or retention type enrollment based pricing information in a level funded pricing rule	<a href="#">Defining Retention Type Claim Based and/or Retention Type Enrollment Based Pricing Rule Information in a Level Funded Pricing Rule</a> on page 2686
How to define characteristics for the level funded pricing rule for a bill group	<a href="#">Defining a Characteristic for a Level Funded Pricing Rule</a> on page 2671





## **Defining Accumulation Criteria in a Level Funded Pricing Rule**





### **Procedure**

To define accumulation criteria in a level funding pricing rule:

1. Ensure that the **Accumulation Criteria** section is expanded only when you have selected an option from the **Price Item** field of the **Main** section while defining a level funded pricing rule.

The **Accumulation Criteria** section contains the following fields:

Field Name	Field Description	Mandatory (Yes or No)						
Accumulation Group ID	<p>Displays a blank field. An accumulation group ID is generated when accumulation parameter values are defined for a level funded pricing rule.</p> <p><b>Note:</b> It is a read-only field.</p>	Not applicable						
Price Items	<p>Used to indicate the price item that you want to include in the accumulation criteria for a bill group.</p> <table border="1"> <thead> <tr> <th>Field Name</th> <th>Field Description</th> <th>Mandatory (Yes or No)</th> </tr> </thead> <tbody> <tr> <td>Price Item</td> <td> <p>Used to indicate the price item which is eligible for level funding.</p> <p><b>Note:</b></p> <p>The <b>Search</b>  icon appears corresponding to the <b>Price Item</b> field. On clicking the <b>Search</b> icon, the <b>Price Item Search</b> window appears.</p> <p>On specifying the price item, the description of the price item appears corresponding to the <b>Price Item</b> field.</p> </td> <td>Not applicable</td> </tr> </tbody> </table> <p><b>Note:</b></p> <p>If you want to add more than one price item in a level funded pricing rule, click the <b>Add</b>  icon.</p> <p>However, if you want to remove a price item from a level funded pricing rule, click the <b>Delete</b>  icon corresponding to the price item.</p>	Field Name	Field Description	Mandatory (Yes or No)	Price Item	<p>Used to indicate the price item which is eligible for level funding.</p> <p><b>Note:</b></p> <p>The <b>Search</b>  icon appears corresponding to the <b>Price Item</b> field. On clicking the <b>Search</b> icon, the <b>Price Item Search</b> window appears.</p> <p>On specifying the price item, the description of the price item appears corresponding to the <b>Price Item</b> field.</p>	Not applicable	Not applicable
Field Name	Field Description	Mandatory (Yes or No)						
Price Item	<p>Used to indicate the price item which is eligible for level funding.</p> <p><b>Note:</b></p> <p>The <b>Search</b>  icon appears corresponding to the <b>Price Item</b> field. On clicking the <b>Search</b> icon, the <b>Price Item Search</b> window appears.</p> <p>On specifying the price item, the description of the price item appears corresponding to the <b>Price Item</b> field.</p>	Not applicable						

Field Name	Field Description	Mandatory (Yes or No)								
Price Item Parameters	Used to indicate the price item parameters that you want to include in the accumulation criteria for a bill group.	Not applicable								
	<table border="1"> <thead> <tr> <th>Field Name</th> <th>Field Description</th> <th>Mandatory (Yes or No)</th> </tr> </thead> <tbody> <tr> <td>Price Item Parameter</td> <td>Used to indicate the price item parameter which is eligible for level funding.   <div style="border: 1px solid black; background-color: #f0f0f0; padding: 5px;"> <p><b>Note:</b></p> <p>The <b>Search</b>  icon appears corresponding to the <b>Price Item Parameter</b> field. On clicking the <b>Search</b> icon, the <b>Price Item Parameter Search</b> window appears.</p> <p>On specifying the price item parameter, the description of the price item parameter appears corresponding to the <b>Parameter Value</b> field.</p> </div> </td> <td rowspan="2">Not applicable</td> </tr> <tr> <td>Parameter Value</td> <td>Used to indicate the parameter values which is eligible for level funding.</td> </tr> </tbody> </table>		Field Name	Field Description	Mandatory (Yes or No)	Price Item Parameter	Used to indicate the price item parameter which is eligible for level funding.  <div style="border: 1px solid black; background-color: #f0f0f0; padding: 5px;"> <p><b>Note:</b></p> <p>The <b>Search</b>  icon appears corresponding to the <b>Price Item Parameter</b> field. On clicking the <b>Search</b> icon, the <b>Price Item Parameter Search</b> window appears.</p> <p>On specifying the price item parameter, the description of the price item parameter appears corresponding to the <b>Parameter Value</b> field.</p> </div>	Not applicable	Parameter Value	Used to indicate the parameter values which is eligible for level funding.
	Field Name		Field Description	Mandatory (Yes or No)						
	Price Item Parameter		Used to indicate the price item parameter which is eligible for level funding.  <div style="border: 1px solid black; background-color: #f0f0f0; padding: 5px;"> <p><b>Note:</b></p> <p>The <b>Search</b>  icon appears corresponding to the <b>Price Item Parameter</b> field. On clicking the <b>Search</b> icon, the <b>Price Item Parameter Search</b> window appears.</p> <p>On specifying the price item parameter, the description of the price item parameter appears corresponding to the <b>Parameter Value</b> field.</p> </div>	Not applicable						
Parameter Value	Used to indicate the parameter values which is eligible for level funding.									
Parameter Value	Used to indicate the parameter values which is eligible for level funding.									
<div style="background-color: #f0f0f0; padding: 5px;"> <p><b>Note:</b></p> <p>If you want to add more than one price item parameter in the accumulation criteria, click the <b>Add</b>  icon.</p> <p>However, if you want to remove a price item parameter from the accumulation criteria, click the <b>Delete</b>  icon corresponding to the price item parameter.</p> </div>										

2. Enter the required details in the **Accumulation Criteria** section.
3. Click **Save**.

The accumulation criteria is defined in the level funded pricing rule.

### **Related Topics**

For more information on...	See...
How to define a level funded pricing rule for a bill group	<a href="#">Defining a Level Funded Pricing Rule for a Bill Group</a> on page 2672
How to edit a level funded pricing rule of a parent customer	<a href="#">Editing a Level Funded Pricing Rule of a Parent Customer</a>

## Defining Claim Pricing Information in a Level Funded Pricing Rule

### Procedure

To define the claim pricing information in the level funded pricing rule:

1. Ensure that the **Pricing Information for rule type category : Claim** zone is expanded only when you have selected an option from the **Price Item** field of the **Main** section while defining or editing a level funded pricing rule for a bill group.

The **Pricing Information for rule type category : Claim** zone contains the following fields:

Field Name	Field Description	Mandatory (Yes or No)
Pricing Rule Type	Used to indicate the claim pricing rule type effective for level funded pricing.	Yes
Derive Using	Used to indicate the method through which the claim pricing rule information is derived. The valid values are: <ul style="list-style-type: none"> <li>• LF Line Items</li> <li>• Pricing Rules</li> </ul>	Yes

If **LF Line Items** option is selected from the **Derive Using** field, the following sub-sections appear:

- **Domestic Provider Claims** – Used to specify the domestic provider claims while calculating the level funding line items.
- **Markup or Markdown Values** – Used to define the markup or markdown values for level funding line items.
- **Line Items** – Used to associate the line items which are eligible for billing.

The **Domestic Provider Claims** section contains the following field:



Field Name	Field Description	Mandatory (Yes or No)
Exclude LF (Percentage)	Used to specify the billable charge line excluding the level funding charge in the percentage to create the domestic provider claim calculation lines.	No

The **Markup or Markdown Values** section contains the following fields:

Field Name	Field Description	Mandatory (Yes or No)
Pricing Strategy	Used to indicate the pricing strategy for the claim line items. The valid values are: <ul style="list-style-type: none"> <li>• Markdown</li> <li>• Markup</li> <li>• None</li> </ul>	Not applicable
Markup or Markdown Type	Used to indicate the markup or markdown value type for the claim line items. The valid values are: <ul style="list-style-type: none"> <li>• Flat Amount</li> <li>• Percentage</li> </ul>	Not applicable

Field Name	Field Description	Mandatory (Yes or No)
Markup or Markdown Amount	Used to specify the markup or markdown amount for the claim line items.  <b>Note:</b> This field displays amount when <b>Markup or Markdown Type</b> field is set as <b>Flat Amount</b> .	Not applicable
Markup / Markdown Included in Settlement?	Used to specify whether markup or markdown amount should be included in the level funding settlement. The valid values are: <ul style="list-style-type: none"> <li>• Yes</li> <li>• No</li> </ul> <b>Note:</b> This field is required when <b>Flat Amount</b> option is selected from the <b>Markup or Markdown Type</b> field.	Yes (Conditional)  <b>Note:</b> This field is required when <b>Flat Amount</b> option is selected from the <b>Markup or Markdown Type</b> field.

The **Line Items** section contains the following field:

Field Name	Field Description	Mandatory (Yes or No)
Line Item	Used to indicate the line item which is eligible for level funded pricing.  <b>Note:</b> The <b>Search</b>  icon appears corresponding to the <b>Line Item</b> field. On clicking the <b>Search</b>  icon corresponding to the <b>Line Item</b> field, the <b>Pricing Rule Line Item Search</b> window appears. On specifying the pricing rule line item, the description of the pricing rule line item appears corresponding to the <b>Line Item</b> field.	No

If **Pricing Rule Type** option is selected from the **Derive Using** field, following sub-sections appear:

- **Claim Pricing Rule** – Used to indicate the claim pricing rule. It contains the following sub-sections:
  - **Domestic Provider Claims** – Used to specify the domestic provider claims while calculating the level funded pricing.
  - **Markup or Markdown Values** – Used to define the markup or markdown values for the billable charge line items.
  - **Line Items** – Used to associate the line items which are eligible for billing.

The **Claim Pricing Rule** section contains the following field:

Field Name	Field Description	Mandatory (Yes or No)
Effective Claim Pricing Rule	Used to indicate the claim pricing rule effective for level funded pricing.	No

**Note:** If you are editing a bill group's level funded pricing rule for the **Claim** rule type category (where the bill group's pricing has ended), a **Reapply** button appears corresponding to the **Effective Claim Pricing Rule** field. You can select an effective claim pricing rule and click the **Reapply** button to set a new pricing for the claim rule type that is eligible for level funding.

The **Domestic Provider Claims** section contains the following field:

Field Name	Field Description	Mandatory (Yes or No)
Exclude (Percentage) LF	Used to specify the billable charge line excluding the level funding charge in the percentage to create the domestic provider claim calculation lines.	No

The **Markup or Markdown Values** section contains the following fields:

Field Name	Field Description	Mandatory (Yes or No)
Pricing Strategy	Used to indicate the pricing strategy for the claim line items. The valid values are: <ul style="list-style-type: none"> <li>• Markdown</li> <li>• Markup</li> <li>• None</li> </ul>	Not applicable
Markup or Markdown Type	Used to indicate the markup or markdown value type for the claim line items. The valid values are: <ul style="list-style-type: none"> <li>• Flat Amount</li> <li>• Percentage</li> </ul>	Not applicable
Markup or Markdown Amount	Used to specify the markup or markdown amount for the claim line items. <p><b>Note:</b> This field displays amount when <b>Markup or Markdown Type</b> field is set as <b>Flat Amount</b>.</p>	Not applicable
Markup / Markdown Included in Settlement?	Used to specify whether markup or markdown amount should be included in the level funding settlement. The valid values are: <ul style="list-style-type: none"> <li>• Yes</li> <li>• No</li> </ul> <p><b>Note:</b> This field is required when <b>Flat Amount</b> option is selected from the <b>Markup or Markdown Type</b> field.</p>	Yes (Conditional) <p><b>Note:</b> This field is required when <b>Flat Amount</b> option is selected from the <b>Markup or Markdown Type</b> field.</p>

The **Line Items** section contains the following fields:

Field Name	Field Description	Mandatory (Yes or No)
Sequence	Displays the sequence number for the line items.	Not applicable
Line Item	Displays the billing line items.	Not applicable



Field Name	Field Description	Mandatory (Yes or No)
Include in Settlement	Used to indicate whether the line item should be included in the level funded claim pricing settlement.	No
Markup or Markdown Included in Settlement	Used to indicate whether markup or markdown should be included in the level funded claim settlement.	No
Markup or Markdown Percentage Eligibility	Used to indicate whether the line item is eligible or not eligible for markup or markdown percentage. The valid values are: <ul style="list-style-type: none"> <li>Eligible</li> <li>Not Eligible</li> </ul>	Not applicable
Markup or Markdown Percentage	Used to indicate the percentage for markup or markdown value.	Not applicable

- Enter the required details in the appropriate sections, based on the option that is selected from the **Derive Using** field.
- If you want to add information for more than one claim pricing rule type to the level funded pricing rule, click the **Add** (+) icon and then repeat step 2.

**Note:** However, if you want to remove information of more than one claim pricing rule type from the level funded pricing rule, click the **Delete** (🗑️) icon corresponding to the pricing rule type field.

- Click **Save**.

The claim line items are defined in the level funded pricing rule.

### Related Topics

For more information on...	See...
How to define level funded pricing rule for a bill group	<a href="#">Defining a Level Funded Pricing Rule for a Bill Group</a> on page 2672
How to edit level funded pricing rule for a bill group	<a href="#">Editing a Level Funded Pricing Rule of a Bill Group</a>

## Defining Ancillary Pricing Information in a Level Funded Pricing Rule

### Procedure

To define the ancillary pricing information in the level funded pricing rule:

- Ensure that the **Pricing Information for rule type category : Ancillary** zone is expanded only when you have selected an option from the **Price Item** field of the **Main** section while defining or editing a level funded pricing rule for a bill group.

The **Pricing Information for rule type category : Ancillary** zone contains the following fields:

Field Name	Field Description	Mandatory (Yes or No)
Pricing Rule Type	Used to indicate the ancillary pricing rule type effective for level funded pricing.	Yes

Field Name	Field Description	Mandatory (Yes or No)
Derive Using	Used to indicate the method through which the ancillary pricing rule information is derived. The valid values are: <ul style="list-style-type: none"> <li>Ancillary Billable Charge Line Type</li> <li>Pricing Rules</li> </ul>	Yes

If **Ancillary Billable Charge Line Type** option is selected from the **Derive Using** field, the following sub-sections appear:

- Billable Charge Line Types** – Used to associate the billable charge line items which are eligible for billing.

The **Billable Charge Line Types** section contains the following field:

Field Name	Field Description	Mandatory (Yes or No)
Billable Charge Line Type	Used to indicate the billable charge line type using which you want to create the calculation line for the charge (i.e. line item). <div style="border: 1px solid black; padding: 5px; margin-top: 10px;"> <p><b>Note:</b></p> <p>The <b>Search</b> (🔍) icon appears corresponding to the <b>Billable Charge Line Type</b> field. On clicking the <b>Search</b> icon, the <b>Billable Charge Line Type Search</b> window appears.</p> <p>On specifying the billable charge line type, the description of the billable charge line type appears corresponding to the <b>Billable Charge Line Type</b> field.</p> </div>	Yes
Rate Based	Used to indicate that the billable charge line type is rate based.	No
Rate	Used to specify the rate for the billable charge line type. <div style="border: 1px solid black; padding: 5px; margin-top: 10px;"> <p><b>Note:</b> This field is enabled when the <b>Rate Based</b> option is selected.</p> </div>	Yes (Conditional) <div style="border: 1px solid black; padding: 5px; margin-top: 10px;"> <p><b>Note:</b> This field is required when the <b>Rate Based</b> option is selected.</p> </div>
Markup / Markdown Included in Settlement?	Used to indicate that markup or markdown amount must be included in the level funding settlement.	No
Pricing Strategy	Used to indicate the pricing strategy for the billable charge line items. The valid values are: <ul style="list-style-type: none"> <li>Markdown</li> <li>Markup</li> <li>None</li> </ul>	Yes

Field Name	Field Description	Mandatory (Yes or No)
Markup or Markdown Type	Used to indicate the markup or markdown type for the billable line items. The valid values are: <ul style="list-style-type: none"> <li>Flat Amount</li> <li>Percentage</li> </ul> <p><b>Note:</b> This field is enabled when the <b>Pricing Strategy</b> option is selected either as <b>Markup</b> or <b>Markdown</b>.</p>	Yes (Conditional) <p><b>Note:</b> This field is required when the <b>Rate Based</b> option is selected either as <b>Markup</b> or <b>Markdown</b>.</p>
Amount/Percentage	Used to specify the amount or percentage for markup or markdown value. <p><b>Note:</b> This field appears only when the <b>Markup or Markdown Type</b> option is selected.</p>	Yes (Conditional) <p><b>Note:</b> This field is required when the <b>Markup or Markdown Type</b> option is selected.</p>

If **Pricing Rule Type** option is selected from the **Derive Using** field, the following zone appears:

- Ancillary Pricing Rule** - Used to indicate the ancillary pricing rule. It contains the following sub-section:
  - The **Billable Charge Line Types** - Used to define the billable charge line types for an ancillary pricing rule, eligible for level funding.

The **Ancillary Pricing Rule** section contains the following field:

Field Name	Field Description	Mandatory (Yes or No)
Effective Ancillary Pricing Rule	Used to indicate the ancillary pricing rule effective for level funded pricing.	No

**Note:** If you are editing a bill group's level funded pricing rule for the **Ancillary** rule type category (where the bill group's pricing has ended), a **Reapply** button appears corresponding to the **Effective Ancillary Pricing Rule** field. You can select an effective ancillary pricing rule and click the **Reapply** button to set a new pricing for the ancillary rule type that is eligible for level funding.

The **Billable Charge Line Types** section contains the following fields:

Field Name	Field Description	Mandatory (Yes or No)
Sequence	Displays the sequence number for the line items.	Not applicable
Billable Charge Line Type	Used to indicate the billable charge line type using which you want to create the calculation line for the charge (i.e. line item). <p><b>Note:</b></p> <p>The <b>Search</b> (🔍) icon appears corresponding to the <b>Billable Charge Line Type</b> field. On clicking the <b>Search</b> icon, the <b>Billable Charge Line Type Search</b> window appears.</p> <p>On specifying the billable charge line type, the description of the billable charge line type appears corresponding to the <b>Billable Charge Line Type</b> field.</p>	Not applicable

Field Name	Field Description	Mandatory (Yes or No)
Include in Settlement	Used to indicate whether the billable charge line item should be included in the level funded ancillary pricing settlement.	Not applicable
Rate Based	Indicates that the billable charge line type is rate based.	Not applicable
Rate	Displays the rate for the billable charge line type.	Not applicable
Markup / Markdown Included in Settlement?	Used to indicate that markup or markdown amount must be included in the level funding settlement.	Not applicable
Pricing Strategy	Displays the pricing strategy for the billable charge line items. The valid values are: <ul style="list-style-type: none"> <li>• Markdown</li> <li>• Markup</li> <li>• None</li> </ul>	Not applicable
Markup or Markdown Type	Indicates the markup or markdown type for the billable charge line items. The valid values are: <ul style="list-style-type: none"> <li>• Flat Amount</li> <li>• Percentage</li> </ul> <div style="border: 1px solid black; padding: 5px; margin-top: 10px;"> <b>Note:</b> This field is enabled when the <b>Pricing Strategy</b> option is selected either as <b>Markup</b> or <b>Markdown</b>. </div>	Not applicable
Amount/ Percentage	Displays the amount or percentage which is specified as the markup or markdown value.	Not applicable

- Enter the required details in the appropriate sections, based on the option selected from the **Derive Using** field.
- If you want to add information for more than one ancillary pricing rule type to the level funded pricing rule, click the **Add** (+) icon and then repeat step 2.

**Note:** However, if you want to remove information of more than one ancillary pricing rule type from the level funded pricing rule, click the **Delete** (🗑️) icon corresponding to the pricing rule type field.

- Click **Save**.

The ancillary line items are defined in the level funded pricing rule.

### **Related Topics**

For more information on...	See...
How to define level funded pricing rule for a bill group	<a href="#">Defining a Level Funded Pricing Rule for a Bill Group</a> on page 2672
How to edit level funded pricing rule for a bill group	<a href="#">Editing a Level Funded Pricing Rule of a Bill Group</a>

## **Defining Discount Arrangement Pricing Information in a Level Funded Pricing Rule**

### **Procedure**

To define the discount arrangement pricing information in the level funded pricing rule:

1. Ensure that the **Pricing Information for rule type category : Discount** zone is expanded only when you have selected an option from the **Price Item** field of the **Main** section while defining or editing a level funded pricing rule for a bill group.

The **Pricing Information for rule type category : Discount** zone contains the following fields:

Field Name	Field Description	Mandatory (Yes or No)
Pricing Rule Type	Used to indicate the discount arrangement pricing rule type which is effective for level-funding.	Yes
Derive Using	Used to indicate the method through which the discount arrangement pricing rule information is derived. The valid values are: <ul style="list-style-type: none"> <li>• Pricing Rules</li> </ul>	Yes

On selecting the **Pricing Rule Type** option from the **Derive Using** field, the following sub-section appears:

- **Discount Pricing Rule** - Used to indicate the discount arrangement pricing rule. It contains the following field:

Field Name	Field Description	Mandatory (Yes or No)
Discount Pricing Rule	Used to indicate the discount arrangement pricing rule which is effective for level funding.	Yes

2. Select the appropriate discount arrangement pricing rule from the **Discount Pricing Rule** section.

**Note:**

On selecting the discount arrangement pricing rule, the system does not generate any line items for the discount arrangement pricing information. This discount arrangement pricing rule is used at the time of level-funding calculations in the TFM module.

3. If you want to add information for more than one discount pricing rule type to the level funded pricing rule, click the **Add (+)** icon and then repeat step 2.

**Note:** However, if you want to remove information of more than one discount pricing rule type from the level funded pricing rule, click the **Delete (🗑)** icon corresponding to the pricing rule type field.

4. Click **Save**.

The discount arrangement pricing information is defined in the level funded pricing rule.

### Related Topics

For more information on...	See...
How to define level funded pricing rule for a bill group	<a href="#">Defining a Level Funded Pricing Rule for a Bill Group</a> on page 2672
How to edit level funded pricing rule for a bill group	<a href="#">Editing a Level Funded Pricing Rule of a Bill Group</a>



## Defining Retention Type Claim Based and/or Retention Type Enrollment Based Pricing Rule Information in a Level Funded Pricing Rule

### Procedure

To define the retention type claim based and/or retention type enrollment based pricing rule information in a level funded pricing rule:

1. Ensure that the **Pricing Information for rule type category : Retention** zone is expanded only when you have selected an option from the **Price Item** field of the **Main** section while defining or editing a level funded pricing rule for a bill group.

The **Pricing Information for rule type category : Retention** zone contains the following fields:

Field Name	Field Description	Mandatory (Yes or No)
Retention Rule Type	Used to indicate the retention type claim based and/or retention type enrollment based pricing rule type for the level funded pricing rule.	Yes
Price Item	Used to indicate the price item for the level funded pricing rule.  <div style="border: 1px solid black; padding: 5px;"> <p><b>Note:</b></p> <p>The <b>Search</b>  icon appears corresponding to the <b>Price Item</b> field. On clicking the <b>Search</b>  icon corresponding to the <b>Price Item</b> field, the <b>Get Retention Type Pricing Rules</b> window appears.</p> <p>On specifying the retention type pricing rule, the description of the retention type pricing rule appears corresponding to the <b>Price Item</b> field.</p> </div>	Yes

2. Select the appropriate **Retention Rule Type** and **Price Item** from the **Pricing Information for rule type category : Retention** zone.

**Note:**

Once the retention type claim based and/or retention type enrollment based pricing rule type is selected along with the price item, the system does not generate line items for the retention type claim/enrollment based pricing rule. This retention type claim/enrollment based pricing rule is used at the time of level-funding calculations in the TFM module.

3. If you want to add more than one retention type claim based and/or retention type enrollment based pricing rule type to the level funded pricing rule, click the **Add**  icon and then repeat step 2.

**Note:** However, if you want to remove more than one retention type claim based and/or retention type enrollment based pricing rule type from the level funded pricing rule, click the **Delete**  icon corresponding to the pricing rule type field.

4. Click **Save**.

The retention type claim based and/or retention type enrollment based pricing rules eligible for level-funding are defined in the level funded pricing rule.

### Related Topics

For more information on...	See...
How to define level funded pricing rule for a bill group	<a href="#">Defining a Level Funded Pricing Rule for a Bill Group</a> on page 2672
How to edit level funded pricing rule for a bill group	<a href="#">Editing a Level Funded Pricing Rule of a Bill Group</a>

## Defining a Characteristic for a Level Funded Pricing Rule

### Prerequisites

To define a characteristic for a level funded pricing rule, you should have:

- Characteristic types defined in the application (where the characteristic entity is set to **Pricing Rule**).

### Procedure

To define a characteristic for a level funded pricing rule:

1. Ensure that the **Characteristics** section is expanded when you are defining or editing a level funded pricing rule.

The **Characteristics** section contains the following fields in the grid:

Column Name	Column Description	Mandatory (Yes or No)
Effective Date	Used to specify the date from when the characteristic is effective for a level funded pricing rule.	Yes (Conditional) <b>Note:</b> This field is required when you are defining a characteristic for a level funded pricing rule.
Characteristic Type	Used to indicate the characteristic type. <b>Note:</b> The list includes only those characteristic types where the characteristic entity is set to <b>Pricing Rule</b> .	Yes (Conditional) <b>Note:</b> This field is required when you are defining a characteristic for a level funded pricing rule.
Characteristic Value	Used to specify the value for the characteristic type. <b>Note:</b> If you select a predefined characteristic type, the <b>Search</b>  icon appears corresponding to the <b>Characteristic Value</b> field. On clicking the <b>Search</b> icon, the <b>Predefined Characteristic Search</b> window appears. On specifying the value for a predefined characteristic type, the description of the characteristic value appears corresponding to the <b>Characteristic Value</b> field.	Yes (Conditional) <b>Note:</b> This field is required when you are defining a characteristic for a level funded pricing rule.

2. Enter the required details in the **Characteristics** section.
3. If you want to define more than one characteristic for the level funded pricing rule, click the **Add**  icon and then repeat step 2.

**Note:** However, if you want to remove a characteristic from the level funded pricing rule, click the **Delete**  icon corresponding to the characteristic.

4. Click **Save**.

The characteristics are defined for the level funded pricing rule.

### **Related Topics**

<b>For more information on...</b>	<b>See...</b>
How to define a level funded pricing rule for a parent customer	<a href="#">Defining a Level Funded Pricing Rule for a Parent Customer</a> on page 2662
How to edit a level funded pricing rule of a parent customer	<a href="#">Editing a Level Funded Pricing Rule of a Parent Customer</a>
How to define a level funded pricing rule for a bill group	<a href="#">Defining a Level Funded Pricing Rule for a Bill Group</a> on page 2672
How to edit a level funded pricing rule for a bill group	<a href="#">Editing a Level Funded Pricing Rule of a Bill Group</a>

## **Pricing Rule (Used for Viewing)**

The **Pricing Rule** screen allows you to:

- View the details of a claim pricing rule of a parent customer
- View the details of a claim pricing rule of a bill group
- View the details of an aggregate stop-loss pricing rule of a parent customer
- View the details of an aggregate stop-loss pricing rule of a bill group
- View the details of a specific stop-loss pricing rule of a parent customer
- View the details of a specific stop-loss pricing rule of a bill group
- View the details of a retention type claim based pricing rule of a parent customer
- View the details of a retention type claim based pricing rule of a bill group
- View the details of a retention type enrollment based pricing rule of a parent customer
- View the details of a retention type enrollment based pricing rule of a bill group
- View the details of a one-time flat fee pricing rule of a bill group
- View the details of a bill period based recurring flat fee pricing rule of a bill group
- View the details of a frequency based recurring flat fee pricing rule of a bill group
- View the details of an ancillary pricing rule of a parent customer
- View the details of an ancillary pricing rule of a bill group
- View the details of a discount arrangement pricing rule of a parent customer
- View the details of a level funded pricing rule of a parent customer
- View the details of a level funded pricing rule of a bill group

This screen consists of the following zones:



- [Claim](#) on page 2689
- [Aggregate Stop-Loss](#) on page 2691
- [Specific Stop-Loss](#) on page 2697
- [Retention Type Claim Based](#) on page 2703
- [Retention Type Enrollment Based](#) on page 2704
- [Flat Fee](#) on page 2705
- [Ancillary](#) on page 2707
- [Discount Arrangement](#) on page 2709
- [Level Funded](#) on page 2712

## Claim

The **Claim** zone displays the details of the claim pricing rule for respective parent customer, bill group or a bill group using a pricing group. It contains the following sections:

- **Main** – Displays basic details about the claim pricing rule. It contains the following fields:

Field Name	Field Description
Parent Customer Information	<p>Displays the parent customer information. In addition, a context menu appears corresponding to this field which helps in navigating to other screens in the application.</p> <p><b>Note:</b> It has a link. On clicking the link, the <b>Person, Account</b> or <b>Policy</b> screen appears where you can view the details of the parent customer. This field appears only when the claim pricing rule is viewed for parent customer.</p>
Bill Group Information	<p>Displays the bill group information. In addition, a context menu appears corresponding to this field which helps in navigating to other screens in the application.</p> <p><b>Note:</b> It has a link. On clicking the link, the <b>Person, Account</b> or <b>Policy</b> screen appears where you can view the details of the bill group. This field appears only when the claim pricing rule is viewed for bill group.</p>
Policy Information	<p>Displays the policy information.</p> <p><b>Note:</b> It has a link. On clicking the link, the <b>Policy</b> screen appears where you can view the details of the policy.</p>
Pricing Rule Type	Indicates the pricing rule type.
Price Item Information	<p>Indicates the price item information.</p> <p><b>Note:</b> It has a link. On clicking the link, the <b>Price Item</b> screen appears where you can view the details of the price item.</p>

Field Name	Field Description
Pricing Start Date	Displays the claim pricing rule start date.
Pricing End Date	Displays the claim pricing rule end date.
Rate Option	Indicates the rate option of the claim pricing rule for the price item.
Claim Template	Indicates the claim template of the claim pricing rule.
Pricing Group	Displays the pricing group of the claim pricing rule.  <b>Note:</b> This field appears only when the claim pricing rule is viewed for pricing group.

- **Markup or Markdown Values** – Lists the markup or markdown values for line items in a claim pricing rule. It contains the following columns:

Column Name	Column Description
Pricing Strategy	Indicates the pricing strategy. The valid values are: <ul style="list-style-type: none"> <li>• Markdown</li> <li>• Markup</li> <li>• None</li> </ul>
Markup or Markdown Type	Indicates the markup or markdown value type for claim pricing rule. The valid values are: <ul style="list-style-type: none"> <li>• Flat Amount</li> <li>• Percentage</li> </ul>
Markup or Markdown Amount	Displays the markup or markdown amount.

- **Line Items** – This section contains the following fields:

Column Name	Column Description
Sequence	Displays the sequence number for the line items.
Line Item	Displays the billing line items.
Billing Eligibility	Displays whether the line item is user defined, eligible or not eligible for billing. The valid values are: <ul style="list-style-type: none"> <li>• Eligible</li> <li>• Not Eligible</li> <li>• User Defined (Default Yes)</li> <li>• User Defined (Default No)</li> </ul>
User Defined Billing Option	Displays whether the billing option is user defined, eligible or not eligible.

Column Name	Column Description
Markup or Markdown Percentage Eligibility	Displays whether the line item is eligible or not eligible for markup or markdown percentage. The valid values are: <ul style="list-style-type: none"> <li>Eligible</li> <li>Not Eligible</li> </ul>
Markup or Markdown Percentage	Displays the percentage for markup or markdown value.

- **Characteristics** – Lists the characteristics defined for the claim pricing rule. It contains the following columns:

Column Name	Column Description
Effective Date	Displays the date from when the characteristic is effective for the claim pricing rule.
Characteristic Type	Indicates the characteristic type.
Characteristic Value	Displays the value of the characteristic type.

### Related Topics

For more information on...	See...
How to view a claim pricing rule of a parent customer	<a href="#">Viewing a Claim Pricing Rule of a Parent Customer</a> on page 2374
How to view a claim pricing rule of a bill group	<a href="#">Viewing a Claim Pricing Rule of a Bill Group</a> on page 2382

## Aggregate Stop-Loss

The **Aggregate Stop-Loss** zone displays the details of the aggregate stop-loss pricing rule for respective parent customer, bill group or a bill group using a pricing group. It contains the following sections:

- **Main** – Displays basic details about the aggregate stop-loss pricing rule. It contains the following fields:

Field Name	Field Description
Parent Customer Information	<p>Displays the parent customer information. In addition, a context menu appears corresponding to this field which helps in navigating to other screens in the application.</p> <div style="border: 1px solid black; padding: 5px;"> <p><b>Note:</b></p> <p>It has a link. On clicking the link, the <b>Person</b>, <b>Account</b> or <b>Policy</b> screen appears where you can view the details of the parent customer.</p> <p>This field appears only when the aggregate stop-loss pricing rule is viewed for parent customer.</p> </div>

Field Name	Field Description
Bill Group Information	<p>Displays the bill group information. In addition, a context menu appears corresponding to this field which helps in navigating to other screens in the application.</p> <p><b>Note:</b> It has a link. On clicking the link, the <b>Person, Account</b> or <b>Policy</b> screen appears where you can view the details of the bill group. This field appears only when the aggregate stop-loss pricing rule is viewed for bill group.</p>
Policy Information	<p>Displays the policy information.</p> <p><b>Note:</b> It has a link. On clicking the link, the <b>Policy</b> screen appears where you can view the details of the policy. This field appears only when the aggregate stop-loss pricing rule is viewed for bill group.</p>
Pricing Rule Type	Indicates the pricing rule type.
Price Item Information	<p>Indicates the price item information.</p> <p><b>Note:</b> It has a link. On clicking the link, the <b>Price Item</b> screen appears where you can view the details of the price item.</p>
Parent Customer's SSL or ASL Pricing Rules	Displays the pricing date range derived from the parent customer's specific stop-loss or aggregate stop-loss pricing rule.
Pricing Start Date	Displays the pricing rule start date.
Pricing End Date	Displays the pricing rule end date.
Rate Option	Indicates the rate option of the aggregate stop-loss pricing rule for the price item.
Settlement Frequency	<p>Indicates the settlement frequency that helps to determine the bill after date. The valid values are:</p> <ul style="list-style-type: none"> <li>• Immediately</li> <li>• Manually (At Required Intervals)</li> <li>• Monthly</li> <li>• Yearly</li> </ul> <p><b>Note:</b> This field appears only when the aggregate stop-loss pricing rule is viewed for parent customer.</p>

Field Name	Field Description
Underwriter Review	<p>Indicates whether the underwriter settlement review flag is on or off. The valid values are:</p> <ul style="list-style-type: none"> <li>• Yes</li> <li>• No</li> </ul> <p><b>Note:</b> This field appears only when the aggregate stop-loss pricing rule is viewed for parent customer.</p>
Pricing Group	<p>Displays the pricing group of the aggregate stop-loss pricing rule.</p> <p><b>Note:</b> This field appears only when the aggregate stop-loss pricing rule is viewed for pricing group.</p>

- **Accumulation Parameters** – Lists the accumulation parameters in an aggregate stop-loss pricing rule. It contains the following fields:

Field Name	Field Description
Accumulation Group ID	Displays the accumulation group ID generated when accumulation parameters are defined for a specific stop-loss..
ASL Credit Account	Indicates the account in which the aggregate stop-loss amount is credited.

This section also lists the following columns:

Column Name	Column Description
Incurred Start Date	Displays the incurred start date based on the accumulated specific stop-loss.
Incurred End Date	Displays the incurred end date based on the accumulated specific stop-loss.
ASL Payout Limit	Displays the maximum limit for the specific stop-loss at member or main subscriber level.
Paid Start Date	Displays the paid start date based on the accumulated specific stop-loss.
Paid End Date	Displays the paid end date based on the accumulated specific stop-loss.
Settlement Days	Indicates the settlement days used in calculating the settlement date.
ASL Limit (During Policy Period)	<p>Indicates the aggregate stop-loss limit that was set during the policy period. The valid values are:</p> <ul style="list-style-type: none"> <li>• Policy Based Limit</li> <li>• Enrollment Based Limit</li> <li>• Percentage of Enrollment Based Limit</li> <li>• Enrollment Based or Minimum ASL Limit (Whichever is Greater)</li> </ul>
ASL Limit (During Settlement Period)	<p>Indicates the aggregate stop-loss limit that was set during the settlement period. The valid values are:</p> <ul style="list-style-type: none"> <li>• Policy Based Limit</li> <li>• Enrollment Based Limit</li> <li>• Enrollment Based or Minimum ASL Limit (Whichever is Greater)</li> </ul>

Column Name	Column Description
Minimum ASL Limit	Displays the minimum ASL limit.  <b>Note:</b> This field displays value only when the <b>Enrollment Based or Minimum ASL Limit (Whichever is Greater)</b> option appears for the <b>ASL Limit (During Policy Period)</b> or <b>ASL Limit (During Settlement Period)</b> field.
Percentage of Enrollment Based Limit	Displays the percentage of enrollment based limit.  <b>Note:</b> This field displays value only when the <b>Percentage of Enrollment Based Limit</b> option appears for the <b>ASL Limit (During Policy Period)</b> field.
Policy Based Limit	Displays the policy based limit.  <b>Note:</b> This field displays value only when the <b>Policy Based Limit</b> option appears for the <b>ASL Limit (During Policy Period)</b> or <b>ASL Limit (During Settlement Period)</b> field.

**Note:** This section appears only when the aggregate stop loss is created for parent customer.

- **Accumulation Criteria** – This section contains the following columns:

Column Name	Column Description						
Accumulation Group ID	Displays the accumulation group ID generated when the accumulation criteria values were defined for a aggregate stop-loss.						
Price Item Information	Displays the price item information.  <b>Note:</b> It has a link. On clicking the link, the <b>Price Item</b> screen appears where you can view the details of the price item.						
Price Item Parameters	This field contains the following columns: <table border="1" data-bbox="574 1234 1183 1688"> <thead> <tr> <th>Column Name</th> <th>Column Description</th> </tr> </thead> <tbody> <tr> <td>Price Item Parameter</td> <td>Displays the multiple parameters based on which you have determined the price item utilization.  <b>Note:</b> It has a link. On clicking the link, the <b>Parameter</b> screen appears where you can view the details of the parameter.</td> </tr> <tr> <td>Parameter Value</td> <td>Displays the value of the parameter.</td> </tr> </tbody> </table>	Column Name	Column Description	Price Item Parameter	Displays the multiple parameters based on which you have determined the price item utilization.  <b>Note:</b> It has a link. On clicking the link, the <b>Parameter</b> screen appears where you can view the details of the parameter.	Parameter Value	Displays the value of the parameter.
Column Name	Column Description						
Price Item Parameter	Displays the multiple parameters based on which you have determined the price item utilization.  <b>Note:</b> It has a link. On clicking the link, the <b>Parameter</b> screen appears where you can view the details of the parameter.						
Parameter Value	Displays the value of the parameter.						

**Note:**

This section appears only when the aggregate stop-loss is created for a bill group.

Accumulation criteria for each rule appears only when the aggregate stop-loss is created for a bill group using a pricing group.

- **Pricing Information** – This section contains the following sub-section:
  - **Claim Pricing Rule** – This sub-section contains the following field:

Field Name	Field Description
Effective Claim Pricing Rule	Indicates the claim pricing rule effective for pricing.

This sub-section contains the following sections:

- **Domestic Provider Claims** – Displays the domestic provider claim while calculating aggregate stop-loss. This section contains the following field:

Field Name	Field Description
Exclude ASL (Percentage)	Displays the domestic provider claim billable charge line excluding the aggregate stop-loss in percentage created for domestic provider claim calculation lines.

- **Markup or Markdown Values** – Displays the markup or markdown values for billable charge line. This section contains the following fields:

Field Name	Field Description
Pricing Strategy	Indicates the pricing strategy. The valid values are: <ul style="list-style-type: none"> <li>• Markdown</li> <li>• Markup</li> <li>• None</li> </ul>
Markup or Markdown Type	Indicates the markup or markdown value type for claim line items. The valid values are: <ul style="list-style-type: none"> <li>• Flat Amount</li> <li>• Percentage</li> </ul>
Markup or Markdown Amount	Displays the markup or markdown amount. <div style="border: 1px solid black; padding: 5px; margin-top: 10px;"> <p><b>Note:</b> This field displays amount when <b>Markup or Markdown Type</b> field is <b>Flat Amount</b>.</p> </div>

- **Line Items** – Displays the associated line items eligible for billing. This section contains the following fields:

Field Name	Field Description
Sequence	Displays the sequence number for the line items.
Line Item	Displays the billing line items.
Eligible for Aggregate Stop-Loss	Displays whether the line item is eligible or not eligible for aggregate stop-loss.
Markup or Markdown Percentage Eligibility	Displays whether the line item is eligible or not eligible for markup or markdown percentage. The valid values are: <ul style="list-style-type: none"> <li>• Eligible</li> <li>• Not Eligible</li> </ul>

Field Name	Field Description
Markup or Markdown Percentage	Displays the percentage for markup or markdown value.

**Note:**

This section appears only when the aggregate stop-loss is created for a bill group.

Claim line items for each rule appears only when the aggregate stop-loss is created for a bill group using a pricing group.

- **Run-In Parameters** – This section contains the following columns:

Column Name	Column Description
Run-In	Displays whether the run-in parameters of the run-in period of policy are to be considered or not in an aggregate stop-loss pricing
Accumulation Group ID	Displays the accumulation group ID that is generated when the accumulation parameter values were defined for an aggregate stop-loss.
Incurred Start Date	Displays the incurred start date based on the run-in period of the policy in the aggregate stop-loss. <b>Note:</b> This field displays value only when the checkbox for the <b>Run-In</b> field is selected.
Incurred End Date	Displays the incurred end date based on the run-in period of the policy in the aggregate stop-loss. <b>Note:</b> This field displays value only when the checkbox for the <b>Run-In</b> field is selected.
Paid Start Date	Displays the paid start date based on the run-in period of the policy in the aggregate stop-loss. <b>Note:</b> This field displays value only when the checkbox for the <b>Run-In</b> field is selected.
Paid End Date	Displays the paid end date based on the run-in period of the policy in the aggregate stop-loss. <b>Note:</b> This field displays value only when the checkbox for the <b>Run-In</b> field is selected.
Run-In Maximum Limit	Displays the maximum limit of the run-in parameters. <b>Note:</b> This field displays value only when the checkbox for the <b>Run-In</b> field is selected.

**Note:** This section appears only when the specific stop loss is created for parent customer.

- **Characteristics** – Lists the characteristics defined for the aggregate stop-loss pricing rule. It contains the following columns:



Column Name	Column Description
Effective Date	Displays the date from when the characteristic is effective for the aggregate stop-loss pricing rule.
Characteristic Type	Indicates the characteristic type.
Characteristic Value	Displays the value of the characteristic type.

### **Related Topics**

For more information on...	See...
How to view an aggregate stop-loss pricing rule of a parent customer	<a href="#">Viewing an Aggregate Stop-Loss Pricing Rule of a Parent Customer</a> on page 2442
How to view an aggregate stop-loss pricing rule of a bill group	<a href="#">Viewing an Aggregate Stop-Loss Pricing Rule of a Bill Group</a> on page 2454

## **Specific Stop-Loss**

The **Specific Stop-Loss** zone displays the details of the specific stop-loss pricing rule for respective parent customer, bill group or a bill group using a pricing group. It contains the following sections:

- **Main** – Displays basic details about the specific stop-loss pricing rule. It contains the following fields:

Field Name	Field Description
Parent Customer Information	<p>Displays the parent customer information. In addition, a context menu appears corresponding to this field which helps in navigating to other screens in the application.</p> <p><b>Note:</b> It has a link. On clicking the link, the <b>Person, Account</b> or <b>Policy</b> screen appears where you can view the details of the parent customer. This field appears only when the specific stop-loss pricing rule is viewed for parent customer.</p>
Bill Group Information	<p>Displays the bill group information. In addition, a context menu appears corresponding to this field which helps in navigating to other screens in the application.</p> <p><b>Note:</b> It has a link. On clicking the link, the <b>Person, Account</b> or <b>Policy</b> screen appears where you can view the details of the bill group. This field appears only when the specific stop-loss pricing rule is viewed for bill group.</p>

Field Name	Field Description
Policy Information	<p>Displays the policy information.</p> <p><b>Note:</b> It has a link. On clicking the link, the <b>Policy</b> screen appears where you can view the details of the policy. This field appears only when the specific stop-loss pricing rule is viewed for parent customer.</p>
Pricing Rule Type	Indicates the pricing rule type.
Price Item Information	<p>Indicates the price item information.</p> <p><b>Note:</b> It has a link. On clicking the link, the <b>Price Item</b> screen appears where you can view the details of the price item.</p>
Parent Customer's SSL Pricing Rule	<p>Displays the pricing date range derived from the parent customer's specific stop-loss pricing rule.</p> <p><b>Note:</b> This field appears only when the specific stop-loss pricing rule is viewed for bill group.</p>
Pricing Start Date	Displays the specific stop-loss pricing rule start date.
Pricing End Date	Displays the specific stop-loss pricing rule end date.
Rate Option	Indicates the rate option of the specific stop-loss pricing rule for the price item.
Pricing Rule Usage	<p>Indicates whether the pricing rule is used only for pricing or for pricing and billing. The valid values are:</p> <ul style="list-style-type: none"> <li>• Pricing</li> <li>• Pricing and Billing</li> </ul> <p><b>Note:</b> This field appears only when the specific stop-loss pricing rule is viewed for parent customer.</p>
Accumulation Level	<p>Indicate whether the specific stop-loss is accumulated at the member or main subscriber level. The valid values are:</p> <ul style="list-style-type: none"> <li>• Member</li> <li>• Main Subscriber</li> </ul> <p><b>Note:</b> This field appears only when the specific stop-loss pricing rule is viewed for parent customer.</p>

Field Name	Field Description
Settlement Frequency	<p>Indicates the settlement frequency that helps to determine the bill after date. The valid values are:</p> <ul style="list-style-type: none"> <li>• Immediately</li> <li>• Manually (At Required Intervals)</li> <li>• Never</li> <li>• Yearly</li> </ul> <p><b>Note:</b> This field appears only when the specific stop-loss pricing rule is viewed for parent customer.</p>
Underwriter Review	<p>Indicates whether the underwriter settlement review flag is on or off. The valid values are:</p> <ul style="list-style-type: none"> <li>• Yes</li> <li>• No</li> </ul> <p><b>Note:</b> This field appears only when the specific stop-loss pricing rule is viewed for parent customer.</p>
Pricing Group	<p>Displays the pricing group of the specific stop-loss pricing rule.</p> <p><b>Note:</b> This field appears only when the specific stop-loss pricing rule is viewed for pricing group.</p>

- **Accumulation Parameters** – Lists the accumulation parameters in a specific stop-loss pricing rule. It contains the following field:

Field Name	Field Description
Accumulation Group ID	Displays the accumulation group ID generated when accumulation parameters are defined for a specific stop-loss..

This section also lists the following columns:

Column Name	Column Description
Incurred Start Date	Displays the incurred start date based on the accumulated specific stop-loss.
Incurred End Date	Displays the incurred end date based on the accumulated specific stop-loss.
SSL Payout Limit	Displays the maximum limit for the specific stop-loss at member or main subscriber level.
Paid Start Date	Displays the paid start date based on the accumulated specific stop-loss.
Paid End Date	Displays the paid end date based on the accumulated specific stop-loss.
Settlement Days	Indicates the settlement days used in calculating the settlement date.
Compute Aggregate SSL (ASL)	<p>Indicates whether the aggregate specific stop-loss (ASSL) is calculated or not during the <b>C1-BCSSL</b> batch run for each bill group. The valid values are:</p> <ul style="list-style-type: none"> <li>• Yes</li> <li>• No</li> </ul>

Column Name	Column Description
ASSL Credit Account	Indicates that the aggregate specific stop-loss amount beyond the ASSL limit paid by the insurance company to the ASSL credit account.
ASSL Limit	

**Note:** This section appears only when the specific stop loss is created for parent customer.

- **Accumulation Criteria** – This section contains the following columns:

Column Name	Column Description						
Accumulation Group ID	Displays the accumulation group ID generated when the accumulation criteria values were defined for a specific stop-loss.						
Run-In Maximum Limit	Displays the maximum specific stop-loss limit defined for the member when the claim transactions were received in the run-in period of the policy.						
SSL Limit	Displays whether the SSL limit indicating the specific stop-loss amount beyond this limit is paid by the insurance company.						
Price Item Information	Displays the price item information. <b>Note:</b> It has a link. On clicking the link, the <b>Price Item</b> screen appears where you can view the details of the price item.						
Price Item Parameters	This field contains the following columns: <table border="1" data-bbox="574 995 1463 1318"> <thead> <tr> <th>Column Name</th> <th>Column Description</th> </tr> </thead> <tbody> <tr> <td>Price Item Parameter</td> <td>Displays the multiple parameters based on which you have determined the price item utilization. <b>Note:</b> It has a link. On clicking the link, the <b>Parameter</b> screen appears where you can view the details of the parameter.</td> </tr> <tr> <td>Parameter Value</td> <td>Displays the value of the parameter.</td> </tr> </tbody> </table>	Column Name	Column Description	Price Item Parameter	Displays the multiple parameters based on which you have determined the price item utilization. <b>Note:</b> It has a link. On clicking the link, the <b>Parameter</b> screen appears where you can view the details of the parameter.	Parameter Value	Displays the value of the parameter.
Column Name	Column Description						
Price Item Parameter	Displays the multiple parameters based on which you have determined the price item utilization. <b>Note:</b> It has a link. On clicking the link, the <b>Parameter</b> screen appears where you can view the details of the parameter.						
Parameter Value	Displays the value of the parameter.						

**Note:**

This section appears only when the specific stop-loss is created for a bill group.

Accumulation criteria for each rule appears only when the specific stop-loss is created for a bill group using a pricing group.

- **Pricing Information** – This section contains the following sub-section:
  - **Claim Pricing Rule** – This sub-section contains the following field:

Field Name	Field Description
Effective Claim Pricing Rule	Indicates the claim pricing rule effective for pricing.

This sub-section contains the following sections:

- **Domestic Provider Claims** – Displays the domestic provider claim while calculating specific stop-loss. This section contains the following field:

Field Name	Field Description
Exclude SSL (Percentage)	Displays the domestic provider claim billable charge line excluding the specific stop-loss in percentage created for domestic provider claim calculation lines.

- **Markup or Markdown Values** – Displays the markup or markdown values for billable charge line. This section contains the following fields:

Field Name	Field Description
Pricing Strategy	Indicates the pricing strategy. The valid values are: <ul style="list-style-type: none"> <li>• Markdown</li> <li>• Markup</li> <li>• None</li> </ul>
Markup or Markdown Type	Indicates the markup or markdown value type for claim line items. The valid values are: <ul style="list-style-type: none"> <li>• Flat Amount</li> <li>• Percentage</li> </ul>
Markup or Markdown Amount	Displays the markup or markdown amount. <div style="border: 1px solid black; padding: 5px; margin-top: 10px;"> <p><b>Note:</b> This field displays amount when <b>Markup or Markdown Type</b> field is <b>Flat Amount</b>.</p> </div>

- **Line Items** – Displays the associated line items eligible for billing. This section contains the following fields:

Field Name	Field Description
Sequence	Displays the sequence number for the line items.
Line Item	Displays the billing line items.
Eligible for Specific Stop-Loss	Displays whether the line item is eligible or not eligible for specific stop-loss.
Markup or Markdown Percentage Eligibility	Displays whether the line item is eligible or not eligible for markup or markdown percentage. The valid values are: <ul style="list-style-type: none"> <li>• Eligible</li> <li>• Not Eligible</li> </ul>
Markup or Markdown Percentage	Displays the percentage for markup or markdown value.

**Note:**  
This section appears only when the specific stop-loss is created for a bill group.  
Claim line items for each rule appears only when the specific stop-loss is created for a bill group using a pricing group.

- **Run-In Parameters** – This section contains the following columns:

Column Name	Column Description
Run-In	Displays whether the run-in parameters of the run-in period of policy are to be considered or not in a specific stop-loss pricing
Incurred Start Date	Displays the incurred start date based on the run-in period of the policy in the specific stop-loss.
Incurred End Date	Displays the incurred end date based on the run-in period of the policy in the specific stop-loss.
Paid Start Date	Displays the paid start date based on the run-in period of the policy in the specific stop-loss.
Paid End Date	Displays the paid end date based on the run-in period of the policy in the specific stop-loss.

**Note:** This section appears only when the specific stop loss is created for parent customer.

- **Lasering and Exclusion** – Lists the lasering and exclusion information in a specific stop-loss pricing rule. It contains the following columns:

Column Name	Column Description
Accumulation Group ID	Displays the accumulation group ID generated when the accumulation parameter values were defined for the specific stop-loss.
Level Identifier	Displays the lasering or exclusion level identifier.
Lasering or Exclusion Level	Indicates the lasering or exclusion level of the specific stop-loss. The valid values are: <ul style="list-style-type: none"> <li>• Main Subscriber</li> <li>• Member</li> <li>• Provider</li> </ul>
Exception Type	Indicates the exception type. The valid values are: <ul style="list-style-type: none"> <li>• Lasering</li> <li>• Exclusion</li> </ul>
Comments	Displays the comments.
Lasered Amount	Displays the lasered amount.

**Note:** This section appears only when the specific stop loss is created for parent customer.

- **Characteristics** – Lists the characteristics defined for the specific stop-loss pricing rule. It contains the following columns:

Column Name	Column Description
Effective Date	Displays the date from when the characteristic is effective for the specific stop-loss pricing rule.
Characteristic Type	Indicates the characteristic type.
Characteristic Value	Displays the value of the characteristic type.

### **Related Topics**

For more information on...	See...
How to view a specific stop-loss pricing rule of a parent customer	<a href="#">Viewing a Specific Stop-Loss Pricing Rule of a Parent Customer</a> on page 2406
How to view a specific stop-loss pricing rule of a bill group	<a href="#">Viewing a Specific Stop-Loss Pricing Rule of a Bill Group</a> on page 2418

## Retention Type Claim Based

The **Retention Type Claim Based** zone displays the details of the Retention Type Claim Based Pricing Rule. This zone contains the following sections:

- **Main** – This section provides basic information about the retention type claim based pricing rule type. It contains the following fields:

Field Name	Field Description
Parent Customer Information	<p>Displays the parent customer information. In addition, a context menu appears corresponding to this field which helps in navigating to other screens in the application.</p> <p><b>Note:</b> It has a link. On clicking the link, the <b>Person</b> screen appears where you can view the details of the parent customer. This field appears only when the retention type claim based pricing rule is viewed for parent customer.</p>
Pricing Rule Type	Displays the pricing rule type.
Price Item Information	<p>Displays the price item.</p> <p><b>Note:</b> It has a link. On clicking the link, the <b>Price Item</b> screen appears where you can view the details of the price item.</p>
Rate Option	Displays the rate option of the retention type claim based pricing rule.
Pricing Start Date	Displays the date from when the pricing is effective for retention type claim based pricing rule.
Pricing End Date	Displays the date till when the pricing is effective for retention type claim based pricing rule.

- **Parameters** – This section lists the parameters which are defined for retention type claim based pricing rule. It contains the following columns:

Column Name	Column Description										
Price Item Parameters	Displays the parameter item information for retention type claim based pricing rule.										
	<table border="1"> <thead> <tr> <th>Column Name</th> <th>Column Description</th> </tr> </thead> <tbody> <tr> <td>Price Item Parameters</td> <td>Displays multiple parameters based on which you have determined the price item utilization.</td> </tr> <tr> <td>Parameter Description</td> <td>Displays the description of the parameter.</td> </tr> <tr> <td>Parameter Value</td> <td>Displays the value of the parameter.</td> </tr> <tr> <td>Parameter Value Description</td> <td>Displays the description of the value, defined as a parameter.</td> </tr> </tbody> </table>	Column Name	Column Description	Price Item Parameters	Displays multiple parameters based on which you have determined the price item utilization.	Parameter Description	Displays the description of the parameter.	Parameter Value	Displays the value of the parameter.	Parameter Value Description	Displays the description of the value, defined as a parameter.
	Column Name	Column Description									
	Price Item Parameters	Displays multiple parameters based on which you have determined the price item utilization.									
	Parameter Description	Displays the description of the parameter.									
Parameter Value	Displays the value of the parameter.										
Parameter Value Description	Displays the description of the value, defined as a parameter.										
Fee	Displays the fee that is applicable for which price item parameters are defined.										

- **Characteristics** – This section displays the pricing rule type characteristics. It contains the following columns:

Column Name	Column Description
Effective Date	Displays the date from when the characteristics are effective.
Characteristic Type	Displays the characteristic type.
Characteristic Value	Displays the value for the characteristic type.

#### Related Topics

For more information on...	See...
<b>Pricing Rule Type</b> screen	<a href="#">Pricing Rule Type</a> on page 2343
<b>Pricing Rule Type</b> zone	<a href="#">Pricing Rule Type</a> on page 2347

## Retention Type Enrollment Based

The **Retention Type Enrollment Based** zone displays the details of the Retention Type Enrollment Based Pricing Rule. This zone contains the following sections:

- **Main** – This section provides basic information about the retention type claim based pricing rule type. It contains the following fields:

Field Name	Field Description
Parent Customer Information	<p>Displays the parent customer information. In addition, a context menu appears corresponding to this field which helps in navigating to other screens in the application.</p> <div style="border: 1px solid black; padding: 5px;"> <p><b>Note:</b></p> <p>It has a link. On clicking the link, the <b>Person</b> screen appears where you can view the details of the parent customer.</p> <p>This field appears only when the retention type enrollment based pricing rule is viewed for parent customer.</p> </div>
Pricing Rule Type	Displays the pricing rule type.



Field Name	Field Description
Price Item Information	Displays the price item. <b>Note:</b> It has a link. On clicking the link, the <b>Price Item</b> screen appears where you can view the details of the price item.
Rate Option	Displays the rate option of the retention type enrollment based pricing rule.
Pricing Start Date	Displays the date from when the pricing is effective for retention type enrollment based pricing rule.
Pricing End Date	Displays the date till when the pricing is effective for retention type enrollment based pricing rule.
Exempt Retro Transactions	Indicates whether retro transactions should be a part of retention type enrollment based pricing rule.

- **Parameters** – This section lists the parameters which are defined for retention type enrollment based pricing rule. It contains the following columns:

Column Name	Column Description										
Price Item Parameters	Displays the parameter item information for retention type enrollment based pricing rule. <table border="1" data-bbox="521 869 1463 1220"> <thead> <tr> <th>Column Name</th> <th>Column Description</th> </tr> </thead> <tbody> <tr> <td>Price Item Parameters</td> <td>Displays multiple parameters based on which you have determined the price item utilization.</td> </tr> <tr> <td>Parameter Description</td> <td>Displays the description of the parameter.</td> </tr> <tr> <td>Parameter Value</td> <td>Displays the value of the parameter.</td> </tr> <tr> <td>Parameter Value Description</td> <td>Displays the description of the value, defined as a parameter.</td> </tr> </tbody> </table>	Column Name	Column Description	Price Item Parameters	Displays multiple parameters based on which you have determined the price item utilization.	Parameter Description	Displays the description of the parameter.	Parameter Value	Displays the value of the parameter.	Parameter Value Description	Displays the description of the value, defined as a parameter.
Column Name	Column Description										
Price Item Parameters	Displays multiple parameters based on which you have determined the price item utilization.										
Parameter Description	Displays the description of the parameter.										
Parameter Value	Displays the value of the parameter.										
Parameter Value Description	Displays the description of the value, defined as a parameter.										
Fee	Displays the fee that is applicable for which price item parameters are defined.										

- **Characteristics** – This section displays the pricing rule type characteristics. It contains the following columns:

Column Name	Column Description
Effective Date	Displays the date from when the characteristics are effective.
Characteristic Type	Displays the characteristic type.
Characteristic Value	Displays the value for the characteristic type.

### Related Topics

For more information on...	See...
<b>Pricing Rule Type</b> screen	<a href="#">Pricing Rule Type</a> on page 2343
<b>Pricing Rule Type</b> zone	<a href="#">Pricing Rule Type</a> on page 2347

## Flat Fee

The **Flat Fee** zone displays the details of the one-time, bill period, and frequency based recurring flat fee pricing rule for bill group. It contains the following sections:

- **Main** – Displays basic details about the one-time, bill period, and frequency based recurring flat fee pricing rule. It contains the following fields:

Field Name	Field Description
Bill Group Information	<p>Displays the bill group information. In addition, a context menu appears corresponding to this field which helps in navigating to other screens in the application.</p> <p><b>Note:</b> It has a link. On clicking the link, the <b>Person, Account or Policy</b> screen appears where you can view the details of the bill group.</p>
Policy Information	<p>Displays the policy information.</p> <p><b>Note:</b> It has a link. On clicking the link, the <b>Policy</b> screen appears where you can view the details of the policy.</p>
Price Item Information	<p>Indicates the price item information.</p> <p><b>Note:</b> It has a link. On clicking the link, the <b>Price Item</b> screen appears where you can view the details of the price item.</p>
Charge Date	<p>Displays the flat fee charge date.</p> <p><b>Note:</b> This field appears only for the one-time flat fee pricing rule for bill group.</p>
Charge Start Date	<p>Displays the flat fee charge start date.</p> <p><b>Note:</b> This field appears only for both bill period and frequency based recurring flat fee pricing rule for bill group.</p>
Charge End Date	<p>Displays the flat fee charge end date.</p> <p><b>Note:</b> This field appears only for both bill period and frequency based recurring flat fee pricing rule for bill group.</p>
Bill To Account Override	<p>Displays the account to which the bill is override. In addition, a context menu appears corresponding to this field which helps in navigating to other screens in the application.</p> <p><b>Note:</b> It has a link. On clicking the link, the <b>Account</b> screen appears where you can view the details of the account.</p>
Billable Charge Line Type	<p>Displays the billable charge line type.</p>
Fee	<p>Displays the amount of flat fee.</p> <p><b>Note:</b> This field appears only when a value is displayed in the <b>Billable Charge Line Type</b> field.</p>
Bill Period	<p>Indicates the bill period for flat fee.</p> <p><b>Note:</b> This field appears only for the bill period based recurring flat fee pricing rule for bill group.</p>

Field Name	Field Description
Frequency	Indicates the frequency for flat fee.  <b>Note:</b> This field appears only for the frequency based recurring flat fee pricing rule for bill group.
Billable Charge Information	Displays the billable charge information.  <b>Note:</b> It has a link. On clicking the link, the <b>Bill Charge ID</b> screen appears where you can view the details of the billable charge.

- **Characteristics** – Lists the characteristics defined for the one-time, bill period, and frequency based recurring flat fee pricing rule. It contains the following columns:

Column Name	Column Description
Effective Date	Displays the date from when the characteristic is effective for the one-time, bill period, and frequency based recurring flat fee pricing rule.
Characteristic Type	Indicates the characteristic type.
Characteristic Value	Displays the value of the characteristic type.

#### Related Topics

For more information on...	See...
How to view a one-time flat fee pricing rule of a bill group	<a href="#">Viewing a One-Time Flat Fee Pricing Rule of a Bill Group</a> on page 2527
How to view a bill period based recurring flat fee pricing rule of a bill group	<a href="#">Viewing a Bill Period Based Recurring Flat Fee Pricing Rule of a Bill Group</a> on page 2542
How to view a frequency based recurring flat fee pricing rule of a bill group	<a href="#">Viewing a Frequency Based Recurring Flat Fee Pricing Rule of a Bill Group</a> on page 2557

#### Ancillary

The **Ancillary** zone displays the details of the ancillary pricing rule for the respective parent customer, bill group, or a bill group using a pricing group. It contains the following sections:

- **Main** – Displays basic details about the ancillary pricing rule. It contains the following fields:

Field Name	Field Description	Mandatory (Yes or No)
Parent Customer Information	Displays the parent customer information. In addition, a context menu appears corresponding to this field which helps in navigating to other screens in the application.  <b>Note:</b> It has a link. On clicking the link, the <b>Person, Account or Policy</b> screen appears where you can view the details of the parent customer.	Not applicable

Field Name	Field Description	Mandatory (Yes or No)
Bill Group Information	Displays the bill group information. In addition, a context menu appears corresponding to this field which helps in navigating to other screens in the application.  <b>Note:</b> It has a link. On clicking the link, the <b>Person, Account or Policy</b> screen appears where you can view the details of the bill group.	Not applicable
Policy Information	Displays the policy information.  <b>Note:</b> It has a link. On clicking the link, the <b>Policy</b> screen appears where you can view the details of the policy.	Not applicable
Pricing Rule Type	Indicates the type of the pricing rule.	Not applicable
Status	Indicates the status of the pricing rule.	Not applicable
Price Item Information	Indicates the price item information.  <b>Note:</b> It has a link. On clicking the link, the <b>Price Item</b> screen appears where you can view the details of the price item.	Not applicable
Pricing Start Date	Displays the date from when the pricing rule is effective.	Not applicable
Pricing End Date	Displays the date till when the pricing rule is effective.	Not applicable
Rate Option	Indicates the rate option of the ancillary pricing rule for the price item.	Not applicable
Pass Through without Markup or Markdown	Indicates that markup or markdown should not be calculated for the ancillary charge.	Not applicable

- **Ancillary Charges** – Lists the accumulation parameters in an aggregate stop-loss pricing rule. It contains the following fields:

Field Name	Field Description	Mandatory (Yes or No)
Billable Charge Line Type	Indicates the billable charge line type using which the ancillary pricing rule type is created.  <b>Note:</b> It has a link. On clicking the link, the <b>Billable Charge Line Type</b> screen appears where you can view the details of the billable charge line type.	Not applicable
Billable	Indicates whether the ancillary billable charge is eligible for billing or not.	Not applicable
Rate Based	Indicates whether the ancillary charge is calculated using a particular rate or not.	Not applicable

Field Name	Field Description	Mandatory (Yes or No)
Rate	Indicates the rate for calculating the ancillary charge.	Not applicable
Pricing Strategy	Indicates the price calculation strategy that is applied while defining the ancillary pricing rule.	Not applicable
Markup or Markdown Type	Indicates the type of charge that is applied while defining the ancillary pricing rule.	Not applicable
Amount / Percentage	Displays the actual proportion of the charge that is applied while defining the ancillary pricing rule.	Not applicable

- **Characteristics** – Lists the characteristics defined for the aggregate stop-loss pricing rule. It contains the following columns:

Column Name	Column Description
Effective Date	Displays the date from when the characteristic is effective for the ancillary pricing rule.
Characteristic Type	Indicates the characteristic type.
Characteristic Value	Displays the value of the characteristic type.

### Related Topics

For more information on...	See...
How to view an ancillary pricing rule of a parent customer	<a href="#">Viewing an Ancillary Pricing Rule of a Parent Customer</a>
How to view an ancillary pricing rule of a bill group	<a href="#">Viewing an Ancillary Pricing Rule of a Bill Group</a>

## Discount Arrangement

The **Discount Arrangement** zone displays the details of the discount arrangement pricing rule for the respective parent customer, bill group, or a bill group using a pricing group. It contains the following sections:

- **Main** – Displays basic details about the discount arrangement pricing rule. It contains the following fields:

Field Name	Field Description	Mandatory (Yes or No)
Parent Customer Information	<p>Displays the parent customer information. In addition, a context menu appears corresponding to this field which helps in navigating to other screens in the application.</p> <div style="border: 1px solid black; padding: 5px; margin-top: 10px;"> <p><b>Note:</b></p> <p>It has a link. On clicking the link, the <b>Person, Account or Policy</b> screen appears where you can view the details of the parent customer.</p> </div>	Not applicable

Field Name	Field Description	Mandatory (Yes or No)
Bill Group Information	Displays the bill group information. In addition, a context menu appears corresponding to this field which helps in navigating to other screens in the application.  <b>Note:</b> It has a link. On clicking the link, the <b>Person, Account</b> or <b>Policy</b> screen appears where you can view the details of the bill group.	Not applicable
Policy Information	Displays the policy information.  <b>Note:</b> It has a link. On clicking the link, the <b>Policy</b> screen appears where you can view the details of the policy.	Not applicable
Pricing Rule Type	Indicates the type of the pricing rule.	Not applicable
Status	Indicates the status of the pricing rule.	Not applicable
Price Item Information	Indicates the price item for which the pricing rule is created.  <b>Note:</b> It has a link. On clicking the link, the <b>Price Item</b> screen appears where you can view the details of the price item.	Not applicable
Rate Option	Indicates the rate option of the discount arrangement pricing rule for the price item.	Not applicable
Pricing Start Date	Displays the date from when the pricing rule is effective.	Not applicable
Pricing End Date	Displays the date till when the pricing rule is effective.	Not applicable
Settlement Frequency	Indicates the settlement frequency which helps to determine the bill after date.	Not applicable

- **Discount Details** – Displays the eligibility criteria for a discount percentage and maximum discount amount that is allowed per claim. It contains the following fields:

Field Name	Field Description	Mandatory (Yes or No)
Price Item Parameter	Displays the parameter using which an eligibility criteria is defined for a discount percentage and maximum amount that is allowed per claim.	Not applicable
Parameter Information	Indicates the order in which the parameter and its value should be displayed in the price item parameter information string across the application.	Not applicable
Parameter Value	Indicates the value of the parameter.	Not applicable
Parameter Value Description	Displays the description of the value, defined as a parameter.	Not applicable

Field Name	Field Description	Mandatory (Yes or No)
Discount Percentage	Displays the discount share or discount guarantee percentage.	Not applicable
Maximum Discount Per Claim	Displays maximum discount amount which is allowed per claim. If the discount amount exceeds the maximum limit per claim, the additional amount is credited to the customer.	Not applicable

- **Discount Limits** – Displays the minimum and maximum discount limit defined on the contract. It contains the following fields:

Field Name	Field Description	Mandatory (Yes or No)
No Limit	Indicates the type of discount limit (minimum or maximum) on the contract.	Not applicable
Discount Credit Account	Indicates the account to which the discount is credited, when the minimum or maximum discount limit is defined on the contract.	Not applicable
Settlement Days	Indicates the number of days which help in calculating the final settlement date.	Not applicable

In addition, it contains the following fields in a grid:

Field Name	Field Description	Mandatory (Yes or No)
Type of Discount	Displays the type of discount.	Not applicable
Select	Indicates the type of discount that is applied on the contract.	Not applicable
Limit Type	Indicates the type of limit defined in the discount arrangement pricing rule.	Not applicable
Amount Limit	Indicates the amount limit (flat minimum or maximum discount) on the contract.	Not applicable

- **Exclusion** – Displays the entity (network or provider) which is excluded in the discount arrangement pricing rule. It contains the following fields:

Field Name	Field Description	Mandatory (Yes or No)
Exclusion Level	Indicates the entity (network hospitals or providers) that are excluded during the discount share or discount guarantee calculation.	Not applicable
Level Identifier	Displays the network or provider ID.	Not applicable

- **Characteristics** – Displays the characteristics defined for the discount arrangement pricing rule. It contains the following columns:

Column Name	Column Description	Mandatory (Yes or No)
Effective Date	Displays the date from when the characteristic is effective for the discount arrangement pricing rule.	Not applicable

Column Name	Column Description	Mandatory (Yes or No)
Characteristic Type	Indicates the characteristic type.	Not applicable
Characteristic Value	Displays the value of the characteristic type.	Not applicable

### Related Topics

For more information on...	See...
How to define a discount arrangement pricing rule for a parent customer	<a href="#">Defining a Discount Arrangement Pricing Rule for a Parent Customer on page 2629</a>

## Level Funded

The **Level Funded** zone displays the details of the level funded pricing rule for the respective parent customer, bill group, or a bill group using a pricing group. It contains the following sections:

- **Main** – Displays basic details about the level funded pricing rule. It contains the following columns:

Column Name	Column Description
Parent Customer Information	<p>Displays the parent customer information. In addition, a context menu appears corresponding to this field which helps in navigating to other screens in the application.</p> <p><b>Note:</b> It has a link. On clicking the link, the <b>Person, Account</b> or <b>Policy</b> screen appears where you can view the details of the parent customer.</p>
Bill Group Information	<p>Displays the bill group information. In addition, a context menu appears corresponding to this field which helps in navigating to other screens in the application.</p> <p><b>Note:</b> It has a link. On clicking the link, the <b>Person, Account</b> or <b>Policy</b> screen appears where you can view the details of the bill group.</p>
Policy Information	<p>Displays the policy information.</p> <p><b>Note:</b> It has a link. On clicking the link, the <b>Policy</b> screen appears where you can view the details of the policy.</p>
Pricing Rule Type	Indicates the type of the pricing rule.
Status	Indicates the status of the pricing rule.
Price Item Information	<p>Indicates the price item for which the pricing rule is created.</p> <p><b>Note:</b> It has a link. On clicking the link, the <b>Price Item</b> screen appears where you can view the details of the price item.</p>
Parent Customer's Pricing Rule	Displays the pricing rule of the parent customer.



Column Name	Column Description
Pricing Start Date	Displays the date from when the pricing rule is effective.
Pricing End Date	Displays the date till when the pricing rule is effective.
Rate Option	Indicates the rate option of the level funded pricing rule for the price item.
Settlement Frequency	Indicates the settlement frequency which helps to determine the bill after date.
Settlement Fund Price Item	Indicates the price item derived from the level funded pricing rule type, used to create the level funded pricing rule type.  <b>Note:</b> The settlement fund price item appears only when the level funded pricing rule is created for a bill group.
Underwriter Review	Indicates whether the underwriter settlement review flag is on or off.

- **Accumulation Parameters** – Displays the accumulation parameters for a parent customer in the level funded pricing rule. It contains the following fields:

Column Name	Column Description
Accumulation Group ID	Displays an accumulation group ID which is generated when accumulation parameter values are defined for a level funded pricing rule.
Settlement Account ID	Indicates the account ID to whom the settlement amount is credited.
Incurred Start Date	Displays the incurred start date (inherited from parent customer's specific stop-loss pricing rule) based on which you want to accumulate the level funded pricing.
Incurred End Date	Displays the incurred end date (inherited from parent customer's specific stop-loss pricing rule) based on which you want to accumulate the level funded pricing.
Paid Start Date	Displays the paid start date (inherited from parent customer's specific stop-loss pricing rule) based on which you want to accumulate the level funded pricing.
Paid End Date	Displays the paid end date (inherited from parent customer's specific stop-loss pricing rule) based on which you want to accumulate the level funded pricing.
Settlement Days	Indicates the number of days as the settlement days which help in calculating the settlement date.

**Note:**

The above section appears only when the level funded pricing rule is created for a parent customer.

- **Accumulation Criteria** – Displays the accumulation criteria for a bill group in the level funded pricing rule. It contains the following columns:

Column Name	Column Description
Accumulation Group ID	Displays the accumulation group ID generated when the accumulation criteria values were defined for a level funding pricing rule type.
Price Item Information	Displays the price item information.  <b>Note:</b> It has a link. On clicking the link, the <b>Price Item</b> screen appears where you can view the details of the price item.

Column Name	Column Description						
Price Item Parameters	This field contains the following columns:						
	<table border="1"> <thead> <tr> <th>Column Name</th> <th>Column Description</th> </tr> </thead> <tbody> <tr> <td>Price Item Parameter</td> <td>Displays the multiple parameters based on which you have determined the price item utilization.  <b>Note:</b> It has a link. On clicking the link, the <b>Parameter</b> screen appears where you can view the details of the parameter.</td> </tr> <tr> <td>Parameter Value</td> <td>Displays the value of the parameter.</td> </tr> </tbody> </table>	Column Name	Column Description	Price Item Parameter	Displays the multiple parameters based on which you have determined the price item utilization.  <b>Note:</b> It has a link. On clicking the link, the <b>Parameter</b> screen appears where you can view the details of the parameter.	Parameter Value	Displays the value of the parameter.
	Column Name	Column Description					
Price Item Parameter	Displays the multiple parameters based on which you have determined the price item utilization.  <b>Note:</b> It has a link. On clicking the link, the <b>Parameter</b> screen appears where you can view the details of the parameter.						
Parameter Value	Displays the value of the parameter.						
Parameter Value	Displays the value of the parameter.						

**Note:**

The above section appears only when the level funded pricing rule is created for a bill group.

The accumulation criteria for each rule appears only when the level funded pricing rule is created for a bill group using a pricing group.

- The **Pricing Information for rule type category : Claim** zone contains the following sections:
  - The **Claim Pricing Rule** section contains the following columns:

Column Name	Column Description
Pricing Rule Type	Indicates the claim pricing rule type effective for the level funded pricing.
Derive Using	Indicates the method through which the claim pricing rule information is derived.
Effective Claim Pricing Rule	Displays the claim pricing rule effective for pricing.

- The **Domestic Provider Claims** section contains the following columns:

Column Name	Column Description
Exclude LF (Percentage)	Displays the billable charge line excluding the level funding charge in the percentage to create the domestic provider claim calculation lines.

- The **Markup or Markdown Values** section contains the following columns:

Column Name	Column Description
Pricing Strategy	Indicates the pricing strategy for the claim line items.
Markup or Markdown Type	Indicates the markup or markdown value type for the claim line items.
Markup or Markdown Amount	Displays the markup or markdown amount for the claim line items.  <b>Note:</b> This field displays amount when <b>Markup or Markdown Type</b> field is set as <b>Flat Amount</b> .
Markup / Markdown Included in Settlement?	Displays whether the markup or markdown amount should be included in the level funding settlement. The valid values are:

- The **Line Items** section contains the following columns:

Column Name	Column Description
Sequence	Displays the sequence number for the line items.
Line Item	Displays the billing line items.
Include in Settlement	Indicates whether the line item should be included in the level funded claim pricing settlement.
Markup or Markdown Included in Settlement	Indicates whether markup or markdown should be included in the level funded claim settlement.
Markup or Markdown Percentage Eligibility	Indicates whether the line item is eligible or not eligible for markup or markdown percentage.
Markup or Markdown Percentage	Indicates the percentage for markup or markdown value.

**Note:**

The above section appears only when the level funded pricing rule is created for a bill group.

- The **Pricing Information for rule type category : Ancillary** zone contains the following sections:
  - The **Ancillary Pricing Rule** section contains the following columns:

Column Name	Column Description
Pricing Rule Type	Indicates the ancillary pricing rule type effective for level funded pricing.
Derive Using	Indicates the method through which the ancillary pricing rule information is derived.
Effective Ancillary Pricing Rule	Displays the ancillary pricing rule effective for pricing.

- The **Billable Charge Line Types** section contains the following columns:

Column Name	Column Description
Sequence	Displays the sequence number for the line items.
Billable Charge Line Type	Indicates the billable charge line type using which you want to create the calculation line for the charge (i.e. line item)
Include in Settlement	Indicates whether the billable charge line item should be included in the level funded ancillary pricing settlement.
Rate Based	Indicates that the billable charge line type is rate based.
Rate	Displays the rate for the billable charge line type.
Markup / Markdown Included in Settlement?	Indicates that markup or markdown amount must be included in the level funding settlement.
Pricing Strategy	Displays the pricing strategy for the billable charge line items.
Markup or Markdown Type	Indicates the markup or markdown type for the billable charge line items.
Amount/Percentage	Displays the amount or percentage which is specified as the markup or markdown value.

**Note:**

The above section appears only when the level funded pricing rule is created for a bill group.

- The **Pricing Information for rule type category : Discount** zone contains the following section:

Column Name	Column Description
Pricing Rule Type	Indicates the discount arrangement pricing rule type which is effective for level-funding.
Derive Using	Indicates the method through which the discount arrangement pricing rule information is derived.

- Discount Pricing Rule** - Indicates the discount arrangement pricing rule. It contains the following columns:

Column Name	Column Description
Discount Pricing Rule	Indicates the discount arrangement pricing rule which is effective for level funding.

**Note:**

The above section appears only when the level funded pricing rule is created for a bill group.

- The **Pricing Information for rule type category : Retention** zone contains the following section:

Column Name	Column Description
Retention Rule Type	Indicates the retention type claim based and/or retention type enrollment based pricing rule type for the level funded pricing rule.  <b>Note:</b> It has a link. On clicking the link, <b>Pricing Rule Type</b> screen appears where you can view the details of the rule type.
Price Item	Indicates the price item for the level funded pricing rule.  <b>Note:</b> It has a link. On clicking the link, <b>Price Item</b> screen appears where you can view the details of the price item.

**Note:**

The above section appears only when the level funded pricing rule is created for a bill group.

- Final Settlement Rules** – Displays the final settlement rules when the customer renews or cancels the contract. It contains the following columns:

Column Name	Column Description
Final Settlement Mode	Displays the final settlement mode when the customer renews the level funded agreement
Final Settlement Option	Indicates the final settlement option when the customer renews the level funded agreement.
Flat/Percentage	Indicates the final settlement payment type when the customer renews the level funded agreement.

Column Name	Column Description
Percentage Retained	Displays the percentage retained by the ASO provider when the customer renews the level funded agreement.
Flat Effective Payout	Displays the actual amount which should be retained by the ASO provider or offered as a discount, when the customer renews the level funded agreement.

The **Renewal Decision** sub-section contains the following columns:

Column Name	Column Description
Renewal Decision	Indicates the upcoming status of the level funded contract.

- **Characteristics** – Displays the characteristics defined for the level funded pricing rule. It contains the following columns:

Column Name	Column Description
Effective Date	Displays the date from when the characteristic is effective for the level funded pricing rule.
Characteristic Type	Indicates the characteristic type.
Characteristic Value	Displays the value of the characteristic type.

### **Related Topics**

For more information on...	See...
How to define a level funded pricing rule for a parent customer	<a href="#">Defining a Level Funded Pricing Rule for a Parent Customer</a> on page 2662



---

# Chapter

# 33

---

## Self-Funded Billing

---

### Topics:

- [Pre-requisites](#)
- [Bill Group Derivation and Pricing Parameters](#)
- [Related Pricing Rule Type Eligibility](#)
- [Price Item Eligibility](#)
- [Self-Funded Billing Process](#)
- [Bill Group Derivation](#)
- [Account and Price Item Derivation \(for the Claim Pricing Rule Type Category\)](#)
- [Account and Price Item Derivation \(for the Specific Stop-Loss and Aggregate Stop-Loss Pricing Rule Type Categories\)](#)
- [Account and Price Item Derivation \(for the Retention Type Claim Based Pricing Rule Type Category\)](#)
- [Account and Price Item Derivation \(for the Retention Type Enrollment Based Pricing Rule Type Category\)](#)
- [Account and Price Item Derivation \(for the Ancillary Pricing Rule Type Category\)](#)
- [Bill After Date Determination](#)

Administrative Services Only (ASO) is an arrangement in which an organization funds its own employee benefit plan such as a health plan but hires an outside firm to perform specific administrative services. For example, an organization may hire an insurance company to evaluate and process claims under its employee health plan, while maintaining the responsibility to pay the claims itself.

Self-Funded plan specifics vary depending on the agreement a company establishes with insurance companies and third-party administrators (TPA). In the self-funded plan, the insurance company may provide little to no degree of insurance protection. ASO services are gaining popularity because many employers, particularly larger ones, explore that the self-funded plan provides the potential financial advantages at an acceptable cost.

Oracle Revenue Management and Billing (ORMB) provides a complete solution in terms of pricing, billing, and revenue management to support the self-funded plans. It also provides risk coverage for offering self-funded plans through the stop-loss services, such as specific stop-loss and aggregate stop-loss. The specific stop-loss solution in ORMB helps the employer in mitigating high-cost claims for individual members. And, the aggregate stop-loss helps the employer in mitigating risk against high-volume claims.

The **Transaction Feed Management (TFM)** module is enhanced to support the self-funded billing. You can upload the claim, enrollment, and ancillary transactions in the system using the **File Upload Interface** feature. You can use the **File Upload Interface** feature to upload transaction data files in the following formats:

- Comma Separated Values
- JavaScript Object Notation
- Fixed Position
- Pipe Separated Values
- Tilde Separated Values
- Extensible Markup Language

Once the claim, enrollment, and ancillary transaction data files are uploaded in the system, you need to:

- Validate Header Details
- Validate Transaction Details and Determine Initial Price Item
- Verify Price Item Pricing
- Rate Transactions Before Billing (if required)
- Create and Update Billable Charge with the SQI values

- Clean-up Unwanted Data

The system provides the flexibility to rate the claim, enrollment, and ancillary transactions either prior to billing or during billing. Based on the business requirements, you can configure the system such that transactions mapped to a price item can be rated at a frequency which is different from the account's billing frequency. For example, daily, weekly, etc.

A new pricing model is introduced for the self-funded health care business which enables you to create pricing rules for:

- Claim
- Specific Stop-Loss
- Aggregate Stop-Loss
- Claim Based Fees
- Enrollment Based Fees
- One-time and Recurring Flat Fees
- Ancillary Charges

Once you create the required pricing structure, you can bill for the claim, enrollment, and ancillary transactions. Once the billable charges for claims, claim based fees, enrollment based fees, and ancillary are created through the transaction aggregation process, you can accumulate the specific stop-loss and aggregate stop-loss and create billable charges for them. Once the required billable charges are created, you can bill them using the charge-based billing batches.



## Pre-requisites

---

To setup the Self-Funded Billing feature, you need to do the following:

- Define the parent customers and bill groups in the system.
- Define the required pricing rule types for different pricing rule type categories, such as **Claim**, **Specific Stop-Loss**, **Aggregate Stop-Loss**, **Retention Type Claim Based**, **Retention Type Enrollment Based**, **Flat Fees**, and **Ancillary**.
- Map the transaction fields appropriately in the primary pricing rule types.
- Attach an algorithm created using the **C1\_TXNBGDRV** algorithm type to the **Bill Group Derivation** system event of the pricing rule type where the pricing rule type category is set to **Claim** or **Retention Type Enrollment Based**.
- Attach an algorithm created using the **C1\_ACCPRIDRV** algorithm type to the **Account and Price Item Derivation** system event of the pricing rule type where the pricing rule type category is set to **Claim**, **Retention Type Claim Based**, **Retention Type Enrollment Based**, or **Ancillary**.
- Attach an algorithm created using the **C1\_ACCPRISL** algorithm type to the **Account and Price Item Derivation** system event of the pricing rule type where the pricing rule type category is set to **Specific Stop-Loss** or **Aggregate Stop-Loss**.
- Attach an algorithm created using the **C1\_BAFTDRV** algorithm type to the **Bill After Date Determination** system event of the pricing rule type where the pricing rule type category is set to **Claim**, **Retention Type Claim Based**, **Retention Type Enrollment Based**, or **Ancillary**.
- Attach an algorithm created using the **SA\_DERV\_POPC** algorithm type to the **TFM - Contract Derivation** algorithm spot of the required divisions.
- Attach an algorithm created using the **C1-VRPR\_POPC** algorithm type to the **TFM - Verify Pricing Post-Processing** algorithm spot of the required divisions.
- Attach an algorithm created using the **C1\_BCHG\_POPC** algorithm type to the **TFM - Billable Charge Post-Processing** algorithm spot of the required divisions.
- Map each transaction record type to either the required rule type or primary pricing rule type.
- Define the pricing groups for the required bill groups.
- Define the required pricing rules for the parent customer and bill groups.
- Define the rate schedules with the following calculation algorithms for different price items:

Price item related to....	Calculation Algorithm
Claim	C1-CLAIMCALC
Specific Stop-Loss	C1-SSLRTCALC
Aggregate Stop-Loss	C1-ASLRTCALC
Retention Type Enrollment Based	None
Flat Fees	None
Ancillary	C1-ANCICALC

- Attach an algorithm created using the **C1-RETFLAT** algorithm type to the **TFM – Rate Pre-Processing** algorithm spot of the required divisions.
- Define the TFM information in the rating option for different price items in the following manner:

Price item related to....	Rate Option			
	Aggregate Transaction	Aggregation Schedule	Ignore Transaction	Rating Criteria
Claim	Yes	As Required	No	RITA
Specific Stop-Loss	No	-	Yes	RITX
Aggregate Stop-Loss	No	-	Yes	RITX
Retention Type Claim Based	Yes	As Required	No	RITA
Retention Type Enrollment Based	Yes	As Required	No	RITA
Ancillary	Yes	As Required	No	RITA

- Define the derivation and pricing parameters for each bill group.
- Set the following option types in the **C1-ASOBLNG** feature configuration:
  - Person Relationship Type
  - Bill Group Policy Person Role
  - Invoice Type Characteristic Type
  - Pricing Group Rule Parameter
  - Billable Charge Line Type Parameter
  - Pricing Arrangement Parameter

### **Related Topics**

For more information on...	See...
How to set up the <b>C1-ASOBLNG</b> feature configuration	<a href="#">Setting the C1-ASOBLNG Feature Configuration</a> on page 2889

## **Bill Group Derivation and Pricing Parameters**

An employer may have different bill groups. Each bill group will handle the claim, enrollment, and ancillary transactions of employees based on the employee attributes, such as location, employment status, employment department, and so on.

Oracle Revenue Management and Billing allows you to define the derivation and pricing parameters, such as source system, parameter 1, parameter 2, parameter 3, and parameter 4 for the bill group. These parameters are used to derive the bill group against which the billable charges created for the claim, enrollment, and ancillary transactions should be billed in the system. The derived bill group is also used for billing the claim based fees, one-time or recurring fees, specific stop-loss credits, and aggregate stop-loss credits. You can define multiple derivation and pricing parameters for a bill group, but the derivation and pricing parameter combination must be unique for a particular duration.

For example, if you want bill group 1 to handle the claim, enrollment, and ancillary transactions of employees:

- Who reside in the Western location of the city
- Who belong to Grade A
- Whose transactions are received from the X system

Then, you need to define the following derivation and pricing parameters for bill group 1:

Bill Group Name	Sort ID	Source System	Parameter 1	Parameter 2	Parameter 3	Parameter 4
Bill Group 1	111	X	Western	Grade A	-	-

### Example 1: Derivation and Pricing Parameters for Bill Group 1

Similarly, if you want bill group 2 to handle the claim, enrollment, and ancillary transactions of employees:

- Who reside in the Eastern location of Mumbai
- Who are the person of Indian origin
- Who belong to Grade A
- Whose transactions are received from the X system

Then, you need to define the following derivation and pricing parameters for bill group 2:

Bill Group Name	Sort ID	Source System	Parameter 1	Parameter 2	Parameter 3	Parameter 4
Bill Group 2	123	X	Eastern	Grade A	Mumbai	India

### Example 2: Derivation and Pricing Parameters for Bill Group 2

In the example 1 and 2, the bill group is derived based on the specified employee attributes only when the source system, parameter 1, parameter 2, parameter 3, and parameter 4 are mapped to the appropriate transaction fields in the primary pricing rule type using which the pricing rules are defined for the bill group. For example,

Pricing Rule Type	Source System	Parameter 1	Parameter 2	Parameter 3	Parameter 4
PR1	External System	Location	Designation	City	Country

### Example 3: Transaction Field Mapping in Primary Pricing Rule Type

You can also define criteria for a rule in a pricing group using the parameters, such as source system, parameter 1, parameter 2, parameter 3, and parameter 4. For example,

Pricing Group	Rule	Source System	Parameter 1	Parameter 2	Parameter 3	Parameter 4
PG1	R1	X	Eastern	Grade A	Mumbai	India
	R2	X	Western	Grade A	-	-

### Example 4: Rules Defined in a Pricing Group

If a pricing rule is defined for a bill group using a pricing group, you can define more than one price in the pricing rule which is offered based on the attributes of the employees. For example,

Pricing Rule	Pricing Group	Rule	Rule Criteria	Pricing Strategy	Markup or Markdown Type	Markup or Markdown Amount
PRRR1	PG1	R1	Source System = X, Parameter 1 = Eastern, Parameter 2 = Grade A, Parameter 3 = Mumbai, Parameter 4 = India	Markup	Flat Amount	\$20
		R2	Source System = X, Parameter 1 = Western, Parameter 2 = Grade A	Markdown	Flat Amount	\$10

### Example 5: Defining a Pricing Rule Using a Pricing Group

In the example 5, the system will use the markup strategy on the claim line items for the employees who satisfy the criteria specified in R1. On the other hand, the system will use the markdown strategy on the claim line items for the employees who satisfy the criteria specified in R2.

The derivation and pricing parameters for the bill group and sort ID combination are effective from a particular date. However, the effective date must fall within the date range defined for the sort ID of the bill group. The source system and parameter 1 are mandatory while defining the derivation and pricing parameters for a bill group.

You can define and edit the derivation and pricing parameters for the bill group and sort ID combination from the **Customer 360° Information** screen. You can also upload the derivation and pricing parameters for one or more bill group and sort ID combinations at the same time using the **Upload Request** feature. You can upload the derivation and pricing parameters for the bill group and sort ID combinations from the **Customer 360° Information** or **Upload Request** screen. Note that you can upload the derivation and pricing parameters for the bill group and sort ID only using the CSV file format.

### Related Topics

For more information on...	See...
<b>Bill Group Derivation and Pricing Parameters</b> zone	<a href="#">Bill Group Derivation and Pricing Parameters</a> on page 208
How to define the derivation and pricing parameters for a bill group and sort ID combination	<a href="#">Defining the Derivation and Pricing Parameters for a Bill Group and Sort ID Combination</a> on page 252
How to edit the derivation and pricing parameters of a bill group and sort ID combination	<a href="#">Editing the Derivation and Pricing Parameters of a Bill Group and Sort ID Combination</a> on page 255
How to create an upload request for the derivation and pricing parameters from the <b>Bill Group Derivation and Pricing Parameters</b> zone	<a href="#">Creating a Bill Group Derivation and Pricing Parameters Upload Request</a> on page 256
How to create an upload request for the derivation and pricing parameters from the <b>Upload Request</b> screen	<a href="#">Creating an Upload Request</a> on page 1660

## Related Pricing Rule Type Eligibility

Oracle Revenue Management and Billing enables you to define eligibility rule type for a related pricing rule type in a primary pricing rule type. If the eligibility rule type is defined of a related pricing rule type, the system checks whether the related pricing rule type is eligible for deriving the transaction legs when it is called during the **Validate Transaction and Derive Price Item (C1-TXNIP)** batch execution. The system searches for all rules which are created using the respective rule type and then executes them one by one in the specified priority until the following conditions are met in a rule:

- The eligibility criteria defined in the rule is satisfied.
- The satisfied rule returns the output parameter and its value as specified in the **Rule Based Related Pricing Rule Type Eligibility Field** and **Rule Based Eligibility Value** fields, respectively, of the primary pricing rule type.
- The **Rule True Action** field in the satisfied rule returns **Success**.

**Note:** At present, the system considers all rules created using the respective rule type irrespective of whether it is effective on the transaction date or not.

If all the above conditions are met in a rule, the system calls the respective related pricing rule type for deriving the transaction legs. If none of the rules created using the rule type are satisfied, the system does not call the respective related pricing rule type for deriving the transaction legs. Let us understand this with the help of an example. If the claim transaction is received with the following details:

- UDF\_CHAR\_1 is set to Western
- UDF\_CHAR\_15 is set Employee

- UDF\_DATE\_1 is set to 11-05-2018
- Transaction Record Type is set to TR1

Transaction Record Type	Primary Pricing Rule Type	Related Pricing Rule Type	Eligibility Rule Type	Rule	Rule's Effective Start Date	Rule's Effective End Date	Priority	Rule Criteria	Output Parameter	Output Parameter Value
TR1	CLAIM	CLAIM BASED FEES	RT1	R1	01-01-2018	31-03-2018	1	UDF_CHAR_1 = Western	UDF_CHAR_15	Director
				R2	01-01-2018	31-03-2018	2	UDF_CHAR_1 = Western	UDF_CHAR_15	Employee
				R3	01-04-2018	30-06-2018	3	UDF_CHAR_1 = Western	UDF_CHAR_15	Employee
				R4	01-07-2018	31-12-2018	4	UDF_CHAR_1 = Western	UDF_CHAR_15	Director
		SPECIFIC STOP-LOSS	RT2	R5	01-01-2018	31-03-2018	1	UDF_CHAR_1 = Western	UDF_CHAR_15	Director
				R6	01-01-2018	31-03-2018	2	UDF_CHAR_1 = Eastern	UDF_CHAR_15	Employee
				R7	01-04-2018	31-12-2018	3	UDF_CHAR_1 = Western	UDF_CHAR_15	Employee
		AGGREGATE STOP-LOSS	RT3	R8	01-04-2018	31-12-2018	1	UDF_CHAR_1 = Eastern	UDF_CHAR_15	Employee
				R9	01-04-2018	31-12-2018	2	UDF_CHAR_1 = Western	UDF_CHAR_15	Director

**Note:** Here, the paid date is mapped to the UDF\_DATE\_1 field in the CLAIM pricing rule type. In addition, the Rule Based Related Pricing Rule Type Eligibility Field field is set to UDF\_CHAR\_15 and the Rule Based Eligibility Value field is set to Employee in the CLAIM pricing rule type.

### Example 1: Related Pricing Rule Type Eligibility Rules

In the example 1, the rules which are created using the RT1 rule type are invoked for the CLAIM BASED FEES pricing rule type in the specified priority. The claim transaction meets the eligibility criteria defined in the R1 rule. But, the output parameter's value specified in the R1 rule does not match the value specified in the Rule Based Eligibility Value field. Therefore, the system executes the rule with the next priority (i.e. R2). The claim transaction meets the eligibility criteria defined in the R2 rule. In addition, the output parameter and its value specified in the R2 rule match the values specified in the Rule Based Related Pricing Rule Type Eligibility Field and Rule Based Eligibility Value fields, respectively. Therefore, the system considers the CLAIM BASED FEES pricing rule type for deriving the transaction legs.

The rules which are created using the RT2 rule type are invoked for the SPECIFIC STOP-LOSS pricing rule type in the specified priority. The claim transaction meets the eligibility criteria defined in the R5 rule. But, the output parameter's value specified in the R5 rule does not match the value specified in the Rule Based Eligibility Value field. Therefore, the system executes the rule with the next priority (i.e. R6). Here, the claim transaction does not meet the eligibility criteria defined in the R6 rule. The system then executes the rule with the next priority (i.e. R7). The claim transaction meets the eligibility criteria defined in the R7 rule. In addition, the output parameter and its value specified in the R7 rule match the values specified in the Rule Based Related Pricing Rule Type Eligibility Field and Rule Based Eligibility Value fields, respectively. Therefore, the system considers the SPECIFIC STOP-LOSS pricing rule type for deriving the transaction legs.

Similarly, the rules which are created using the RT3 rule type are invoked for the AGGREGATE STOP-LOSS pricing rule type in the specified priority. The claim transaction does not meet the eligibility criteria defined in the R8 rule. Therefore, the system executes the rule with the next priority (i.e. R9). The claim transaction meets the eligibility criteria defined in the R9 rule. But, the output parameter's value specified in the R9 rule does not match the value specified in

the **Rule Based Eligibility Value** field. As none of the rules created using the rule type met the criteria, the system does not consider the AGGREGATE STOP-LOSS pricing rule type for deriving the transaction legs.

## Price Item Eligibility

Oracle Revenue Management and Billing enables you to define eligibility rule type for a price item in a pricing rule type. If the eligibility rule type is defined of a price item, the system checks whether the price item is eligible for billing when the pricing rule type is called during the **Validate Transaction and Derive Price Item (C1-TXNIP)** batch execution. The system searches for all rules which are created using the respective rule type and then executes them one by one in the specified priority until the following conditions are met in a rule:

- The eligibility criteria defined in the rule is satisfied.
- The satisfied rule returns the output parameter and its value as specified in the **Rule Based Price Item Eligibility Field** and **Rule Based Eligibility Value** fields, respectively, of the pricing rule type.
- The **Rule True Action** field in the satisfied rule returns **Success**.

**Note:** At present, the system considers all rules created using the respective rule type irrespective of whether it is effective on the transaction date or not.

If all the above conditions are met, the system searches for an effective pricing rule for the respective price item. If none of the rules created using the rule type are satisfied, the system does not map the transaction to the price item. Let us understand this with the help of an example. If the claim transaction is received with the following details:

- UDF\_CHAR\_1 is set to Western
- UDF\_CHAR\_20 is set to Employee
- UDF\_DATE\_1 is set to 05-03-2018
- Transaction Record Type is set to TR1

Transaction Record Type	Primary Pricing Rule Type	Price Item	Eligibility Rule Type	Rule	Rule's Effective Start Date	Rule's Effective End Date	Priority	Rule Criteria	Output Parameter	Output Parameter Value
TR1	CLAIM	P1	RT1	R1	01-01-2018	31-03-2018	1	UDF_CHAR_1 = Western	UDF_CHAR_20	Director
				R2	01-01-2018	31-03-2018	2	UDF_CHAR_1 = Western	UDF_CHAR_20	Employee
				R3	01-04-2018	30-06-2018	3	UDF_CHAR_1 = Western	UDF_CHAR_20	Employee
				R4	01-07-2018	31-12-2018	4	UDF_CHAR_1 = Western	UDF_CHAR_20	Director
	P2	RT2	R5	01-01-2018	31-03-2018	1	UDF_CHAR_1 = Western	UDF_CHAR_20	Director	
			R6	01-01-2018	31-03-2018	2	UDF_CHAR_1 = Eastern	UDF_CHAR_20	Employee	
			R7	01-04-2018	31-12-2018	3	UDF_CHAR_1 = Western	UDF_CHAR_20	Employee	

**Note:** Here, the paid date is mapped to the **UDF\_DATE\_1** field in the CLAIM pricing rule type. In addition, the **Rule Based Related Pricing Rule Type Eligibility Field** field is set to **UDF\_CHAR\_20** and the **Rule Based Eligibility Value** field is set to **Employee** in the CLAIM pricing rule type.

### Example 1: Price Item Eligibility Rules

In the example 1, the rules which are created using the RT1 rule type are invoked for P1 in the specified priority. The claim transaction meets the eligibility criteria defined in the R1 rule. But, the output parameter's value specified in the R1 rule does not match the value specified in the **Rule Based Eligibility Value** field. Therefore, the system executes the rule with the next priority (i.e. R2). The claim transaction meets the eligibility criteria defined in the R2 rule. In addition, the output parameter and its value specified in the R2 rule match the values specified in the **Rule Based Price Item Eligibility Field** and **Rule Based Eligibility Value** fields, respectively. Therefore, the system considers P1 for billing and maps the claim transaction to P1 if an effective pricing rule, account, and active contract are available for P1.

Similarly, the rules which are created using the RT2 rule type are invoked for P2 in the specified priority. The claim transaction meets the eligibility criteria defined in the R5 rule. But, the output parameter's value specified in the R5 rule does not match the value specified in the **Rule Based Eligibility Value** field. Therefore, the system executes the rule with the next priority (i.e. R6). Here, the claim transaction does not meet the eligibility criteria defined in the R6 rule. The system then executes the rule with the next priority (i.e. R7). The claim transaction meets the eligibility criteria defined in the R7 rule. In addition, the output parameter and its value specified in the R7 rule match the values specified in the **Rule Based Price Item Eligibility Field** and **Rule Based Eligibility Value** fields, respectively. Therefore, the system considers P2 for billing and maps the claim transaction to P2 if an effective pricing rule, account, and active contract are available for P2.

## Self-Funded Billing Process

---

The **Self-Funded Billing** process consists of the following sub-processes:

- [Transaction Aggregation](#) on page 2727
- [Stop Loss Calculation](#) on page 2732
- [Bill Generation](#) on page 2732

### Transaction Aggregation

Once the claim, enrollment, and ancillary transactions are uploaded, you can create billable charges for the following using the **Transaction Aggregation** process in the **Transaction Feed Management (TFM)** module:

- Claim
- Claim Based Fees
- Retroactive Enrollment Fees
- Non-retroactive Enrollment Fees
- Ancillary

The transaction calculation lines for specific stop-loss and aggregate stop-loss are created during the **Transaction Aggregation** process. Earlier, the **Transaction Aggregation** process was designed to meet the requirements of the **Payments** and **Financial Services** industries. Now, in addition, it is tuned slightly to meet the requirements of the self-funded health care business. The changes are made in the following batches which are executed in the **Transaction Aggregation** process:

- **Validate Transaction and Derive Price Item (C1-TXNIP)** - During this batch execution, the system validates the transaction. If the transaction validation fails due to any reason, the status of the transaction is changed to **Error**. If the transaction validation is successful, the system checks whether a primary pricing rule type is specified in the respective transaction record type. If a primary pricing rule type is not specified in the transaction record type, the system maps the transaction to one or more price item, price item parameters, and account combinations using the rules which are invoked through the rule type. However, if a primary pricing rule type is specified in the transaction record type, the system calls the primary pricing rule type and invokes the algorithms which are attached to the following system events of the primary pricing rule type in the specified sequence:
  1. **Transaction Validation** - At present, the product has not shipped an algorithm type for the **Transaction Validation** system event. If required, you can create a custom algorithm type which validates the transaction before deriving the transaction legs.

2. **Bill Group Derivation** - For more information, refer to the [Bill Group Derivation](#) on page 2733 section.
3. **Account and Price Item Derivation** - Depending on the category to which the pricing rule type belongs, you need to attach different algorithm to the **Account and Price Item Derivation** system event. The following table lists the algorithms that you can attach to a primary pricing rule types with different category:

Pricing Rule Type Category	Algorithm	For more information on how the system derives the transaction legs, refer to...
Claim	C1_ACCPRIDRV	<a href="#">Account and Price Item Derivation (for the Claim Pricing Rule Type Category)</a> on page 2736
Retention Type Enrollment Based	C1_ACCPRIDRV	<a href="#">Account and Price Item Derivation (for the Retention Type Enrollment Based Pricing Rule Type Category)</a> on page 2766
Ancillary	C1_ACCPRIDRV	<a href="#">Account and Price Item Derivation (for the Ancillary Pricing Rule Type Category)</a> on page 2776

This batch then calls the eligible related pricing rule types (if any) defined in the primary pricing rule type. Note that the related pricing rule types are called one by one in the specified sequence. The system invokes the algorithms which are attached to the following system events of the related pricing rule type in the specified sequence:

1. **Transaction Validation** - At present, the product has not shipped an algorithm type for the **Transaction Validation** system event. If required, you can create a custom algorithm type which validates the transaction before deriving the transaction legs.
2. **Account and Price Item Derivation** - Depending on the category to which the pricing rule type belongs, you need to attach different algorithm to the **Account and Price Item Derivation** system event. The following table lists the algorithms that you can attach to a related pricing rule type with different category:

Pricing Rule Type Category	Algorithm	For more information on how the system derives the transaction legs, refer to...
Specific Stop-Loss	C1_ACCPRISL	<a href="#">Account and Price Item Derivation (for the Specific Stop-Loss and Aggregate Stop-Loss Pricing Rule Type Categories)</a> on page 2741
Aggregate Stop-Loss	C1_ACCPRISL	<a href="#">Account and Price Item Derivation (for the Specific Stop-Loss and Aggregate Stop-Loss Pricing Rule Type Categories)</a> on page 2741
Retention Type Claim Based	C1_ACCPRIDRV	<a href="#">Account and Price Item Derivation (for the Retention Type Claim Based Pricing Rule Type Category)</a> on page 2754

The following figure graphically explains the execution process of the **Validate Transaction and Derive Price Item (C1-TXNIP)** batch:



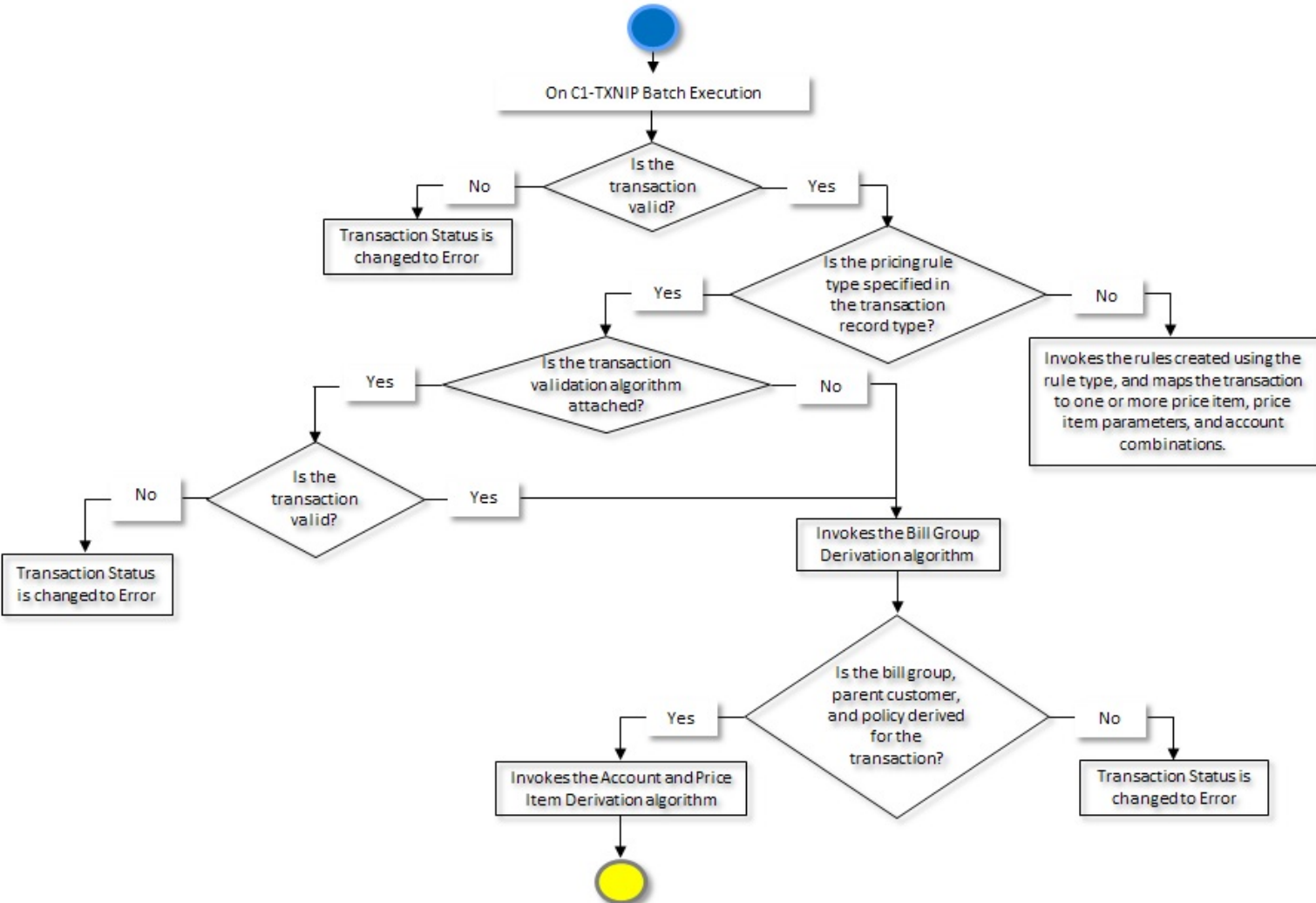

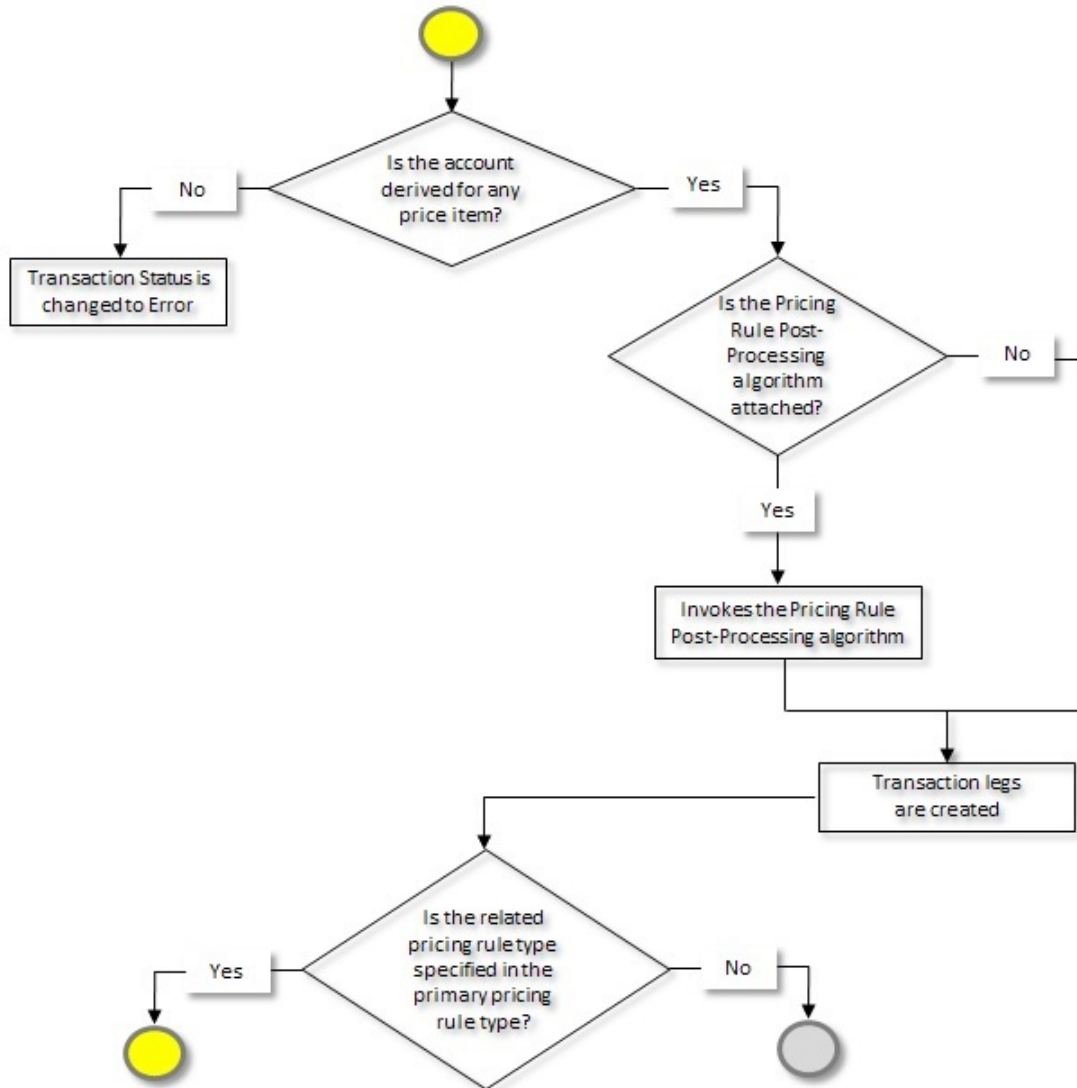

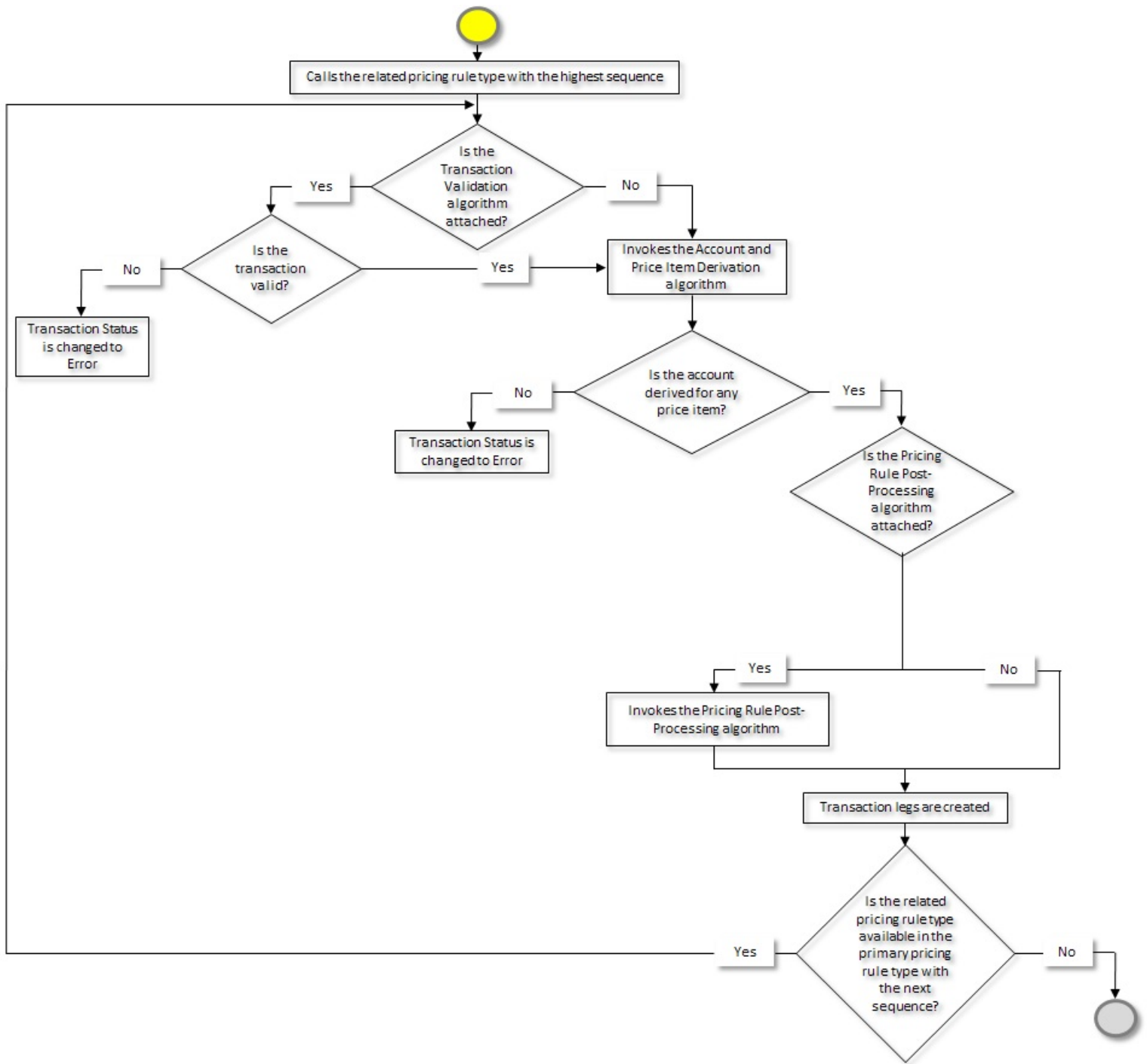

- **Price Item Pricing Verification (C1-TXNVP)** - During this batch execution, the system derives an effective pricing for each transaction leg on the processing date. For more information, refer to the [Price Item Pricing Verification](#) on page 870 section. In addition, the system invokes the algorithms attached to the following algorithm spots of the derived account's division in the specified sequence for the self-funded health care business:

1. **TFM - Contract Derivation** - You can attach an algorithm created using the SA\_DERV\_POPC algorithm type to this algorithm spot. If the account has multiple active contracts of the contract type which is associated with the price item, this algorithm derives the contract which is associated with the policy and

maps it to the transaction leg. The manner in which the system derives the active contract for the account differs in the following scenarios:

If the effective pricing rule stamped against the transaction leg is defined at ...	Then...
The bill group level	The system first fetches the policy derived for the transaction and then derives the active contract which is associated with the policy.
The parent customer level	The system first fetches the bill group to which the account belongs and then the policy where the bill group is associated with the policy using the policy person role which is specified in the <b>Bill Group Policy Person Role</b> option type of the <b>C1-ASOBLNG</b> feature configuration. Once the policy is derived, the system derives the active contract which is associated with the policy.

2. **TFM - Verify Pricing Post-Processing** - You can attach an algorithm created using the **C1-VRPR\_POPC** algorithm type to this algorithm spot. This algorithm removes the price assignment ID and price item parameter group ID from the summary ID column of each transaction leg.
- **Service Quantity Calculation (C1-TXNSQ)** - During this batch execution, the system aggregates the transaction legs, creates a billable charge, and updates the SQI values in the billable charge. For more information, refer to the [Aggregation](#) on page 875 section. In addition, the system invokes the algorithm attached to the following algorithm spot of the derived account's division for the self-funded health care business:
    - **TFM - Billable Charge Post Processing** - You can attach an algorithm created using the **C1\_BCHG\_POPC** algorithm type to this algorithm spot. This algorithm invokes the algorithm which is attached to the **Bill After Date Determination** system event of the respective pricing rule type. For more information, refer to the [Bill After Date Determination](#) on page 2785 section.

## Stop Loss Calculation

Oracle Revenue Management and Billing enables you to accumulate the specific stop-loss and aggregate stop-loss and create billable charges for them. Once the transaction calculation lines for specific stop-loss and aggregate stop-loss are created using the transaction aggregation process, you need to execute the following batches in the specified sequence:

1. Stamp Accumulate After Date Batch (C1-STAAD)
2. Accumulate Specific Stop Loss (C1-ACSSL)
3. Create Specific Stop-Loss Billable Charge (C1-BCSSL)
4. Accumulate Aggregate Stop Loss (C1-ACASL)
5. Create Aggregate Stop-Loss Billable Charge (C1-BCASL)

For more information about these batches, see *Oracle Revenue Management and Billing Batch Guide*.

## Bill Generation

Once the billable charges are created for claim, claim based fees, specific stop-loss credits, aggregate stop-loss credits, enrollment based fees, and ancillary, you need to execute the following charge-based billing batches in the specified sequence to generate bills for the self-funded employer:

1. Pending Bill Generation (C1-PNDBL)
2. Bill Segment Generation (C1-BLGEN)

### 3. Bill Completion (C1-BLPPR)

For more information about these batches, see *Oracle Revenue Management and Billing Batch Guide*.

## Bill Group Derivation

The **Validate Transaction and Derive Price Item (C1-TXNIP)** batch derives the bill group, parent customer, and policy for the claim, enrollment, and ancillary transactions. This is possible only when an algorithm created using the **C1\_TXNBGDRV** algorithm type is attached to the **Bill Group Derivation** system event of the primary pricing rule type. The derived bill group is used for billing the following (if any):

- Claim Charges
- Claim Based Fees
- Specific Stop-Loss (SSL) Credits
- Aggregate Stop-Loss (ASL) Credits
- Retroactive Enrollment Fees
- Non-retroactive Enrollment Fees
- One-time or Recurring Fees
- Ancillary Charges

To derive a bill group, the system first determines the derivation date. The paid date is considered as the derivation date while processing the claim transactions. The coverage end date is considered as the derivation date while processing the retroactive enrollment transactions. And, the coverage start date is considered as the derivation date while processing the non-retroactive enrollment transactions. If the system cannot determine the derivation date, the status of the transaction is changed to **Error**.

Depending on the transaction fields which are mapped to source system, parameter 1, parameter 2, parameter 3, and parameter 4 in the primary pricing rule type, the system derives the data from the transaction. For example, if the source system is mapped to the **External System** field, parameter 1 is mapped to the **Location** field, parameter 2 is mapped to the **Designation** field, parameter 3 is mapped to the **Employee Group** field, and parameter 4 is mapped to the **Nationality** field, the system derives these details from the transaction. Based on the data available in the transaction, the system derives a bill group using the derivation and pricing parameters which are defined for the bill group. Note that the system considers the derivation and pricing parameters which are effective on the derivation date. For example, if the following derivation and pricing parameters are defined for the Bill Group 1 and Bill Group 2:

Bill Group Name	Sort ID	Effective Date	Source System	Parameter 1	Parameter 2	Parameter 3	Parameter 4
Bill Group 1	123	01-01-2018	X	Eastern	Senior Manager	BG1	Indian
Bill Group 1	132	01-04-2018	X	Western	Senior Manager	-	-
Bill Group 1	156	01-07-2018	Y	Eastern	Senior Manager	BG1	Indian
Bill Group 1	163	01-10-2018	Y	Western	Senior Manager	-	-
Bill Group 2	172	01-01-2018	Y	Eastern	-	-	-
Bill Group 2	181	01-04-2018	Y	Western	-	-	-
Bill Group 2	122	01-07-2018	X	Eastern	-	-	-
Bill Group 2	112	01-10-2018	X	Western	-	-	-

Now, if the system receives a claim transaction with the following details:

- External System is set to X
- Location is set to Western
- Designation is set to Senior Manager
- Paid Date is set to 12-05-2018

In this example, the derivation and pricing parameters defined for the Bill Group 1 and 132 (sort ID) combination are effective on the paid date, and therefore the system derives Bill Group 1 for billing the claim transaction. Let us take another example where the system receives a retroactive enrollment transaction with the following details:

- External System is set to X
- Location is set to Eastern
- Designation is set to Senior Manager
- Employee Group is set to BG1
- Nationality is set to Indian
- Coverage Start Date is set to 01-01-2018
- Coverage End Date is set to 31-03-2018

In this example, the derivation and pricing parameters defined for the Bill Group 1 and 123 (sort ID) combination are effective on the coverage end date, and therefore the system derives Bill Group 1 for billing the retroactive enrollment transaction.

In the above two examples, the system could find the exact match for the bill group in the system. However, if the exact match is not available, the system finds the bill group using the best fit match. For example, if the system receives a claim transaction with the following details:

- External System is set to Y
- Location is set to Western
- Designation is set to Senior Manager
- Employee Group is set to BG2
- Nationality is set to Indian
- Paid Date is set to 01-06-2018

In this example, the system could not find the effective derivation and pricing parameters with exact match (i.e. Source System = Y, Location = Western, Designation = Senior Manager, Employee Group = BG2, and Nationality = Indian) on the paid date. Therefore, it searches for the best fit match.

While searching for the best fit match, the system first rules out the optional parameter 4 (i.e. Nationality = Indian) and then checks whether the effective derivation and pricing parameters, where Source System = Y, Location = Western, Designation = Senior Manager, and Employee Group = BG2, are available on the paid date. If so, it considers the derivation and pricing parameters and accordingly derives the bill group. If not, the system then rules out the optional parameter 3 (i.e. Employee Group = BG2) and then checks whether the effective derivation and pricing parameters, where Source System = Y, Location = Western, and Designation = Senior Manager, are available on the paid date. If so, it considers the derivation and pricing parameters and accordingly derives the bill group. If not, the system then rules out the optional parameter 2 (i.e. Designation = Senior Manager) and then checks whether the effective derivation and pricing parameters, where Source System = Y and Location = Western, are available on the paid date. If so, it considers the derivation and pricing parameters and accordingly derives the bill group. If not, the status of the transaction is changed to **Error**.

In this example, the derivation and pricing parameters, where Source System = Y and Location = Western, defined for the Bill Group 2 and 181 (sort ID) combination are considered as the best fit match. Therefore, the system derives Bill Group 2 for billing the claim transaction. Let us take another example where the system receives a non-retroactive enrollment transaction with the following details:

- External System is set to Y
- Location is set to Eastern
- Designation is set to Senior Manager
- Employee Group is set to BG1
- Nationality is set to Indian
- Coverage Start Date is set to 01-01-2018
- Coverage End Date is set to 31-03-2018

In this example, the system could not find the effective derivation and pricing parameters with exact match (i.e. Source System = Y, Location = Eastern, Designation = Senior Manager, Employee Group = BG1, and Nationality = Indian) on the coverage start date. Therefore, it searches for the best fit match. The derivation and pricing parameters, where Source System = Y and Location = Eastern, defined for the Bill Group 2 and 172 (sort ID) combination are considered as the best fit match. Therefore, the system derives Bill Group 2 for billing the non-retroactive enrollment transaction.

Once the bill group is derived, the system derives the parent customer of the bill group. Once the parent customer is derived, the system derives the policy for the transaction in the following manner:

If the transaction is a...	Then...
Claim Transaction	<p>The system checks whether the paid date of the claim transaction falls within the policy start date and runout end date of any policy where:</p> <ul style="list-style-type: none"> <li>• The bill group is associated with the policy using the policy person role which is specified in the <b>Bill Group Policy Person Role</b> option type of the <b>C1-ASOBLNG</b> feature configuration.</li> <li>• The status of the policy is set to either of the following: <ul style="list-style-type: none"> <li>• In Force/Active</li> <li>• Runout</li> <li>• Post Runout</li> </ul> </li> </ul>
Retroactive Enrollment Transaction	<p>The system checks whether the coverage end date falls within the policy start date and policy end date of any policy where:</p> <ul style="list-style-type: none"> <li>• The bill group is associated with the policy using the policy person role which is specified in the <b>Bill Group Policy Person Role</b> option type of the <b>C1-ASOBLNG</b> feature configuration.</li> <li>• The status of the policy is set to <b>In Force/Active</b>.</li> </ul>
Non-retroactive Enrollment Transaction	<p>The system checks whether the coverage start date falls within the policy start date and policy end date of any policy where:</p> <ul style="list-style-type: none"> <li>• The bill group is associated with the policy using the policy person role which is specified in the <b>Bill Group Policy Person Role</b> option type of the <b>C1-ASOBLNG</b> feature configuration.</li> <li>• The status of the policy is set to <b>In Force/Active</b>.</li> </ul>

If the system cannot derive the policy for the transaction, the status of the transaction is changed to **Error**.

## Account and Price Item Derivation (for the Claim Pricing Rule Type Category)

The **Validate Transaction and Derive Price Item (C1-TXNIP)** batch maps a claim transaction to one or more price item and price item parameters which are defined in the respective primary pricing rule type. This is possible only when an algorithm created using the **C1\_ACCPRIDRV** algorithm type is attached to the **Account and Price Item Derivation** system event of the primary pricing rule type.

**Note:** If you have specified the price item parameters (for which the parameter usage is set to **Pricing**) in the pricing rule types where the pricing rule type category is set to **Claim**, the system does not use these price item parameters while searching for an effective pricing rule for the respective price items. However, you can use these price item parameters while defining the accumulation criteria in the related pricing rule types where the pricing rule type category is set to **Specific Stop-Loss** or **Aggregate Stop-Loss**.

This algorithm fetches the effective pricing rule for each price item specified in the primary pricing rule type on the derivation date. The system considers the paid date as the derivation date while fetching the effective pricing rules for the claim transactions. This algorithm first searches for the effective pricing rule for a price item which is defined for the policy at the bill group level. If the system does not find any effective pricing rule for a price item which is defined for the policy at the bill group level, it inherits the effective pricing rule for a price item from the parent customer level.

For example, if the system receives a claim transaction with the following details:

- UDF\_DATE\_1 is set to 15-01-2018
- Transaction Record Type is set to TR1

Let us assume that the following pricing structure is defined in the system:

Transaction Record Type	Primary Pricing Rule Type	Price Item	Pricing Rule	Pricing Start Date	Pricing End Date	Assignment Level
TR1	CLAIM	P1	C1P1	01-01-2018	31-12-2018	Parent Customer
			C2P1	01-01-2018	31-12-2018	Bill Group
			C3P1	01-01-2019	30-06-2019	Bill Group
		P2	C1P2	01-06-2017	31-12-2017	Bill Group
			C2P2	01-01-2018	31-12-2018	Parent Customer
			C3P2	01-01-2019	30-06-2019	Bill Group

**Note:** Here, the paid date is mapped to the **UDF\_DATE\_1** field in the CLAIM pricing rule type.

### Example 1: Effective Pricing Rule Derivation

In the example 1, the system fetches C2P1 and C2P2 pricing rules for P1 and P2, respectively, which are effective on the paid date. Note that the effective pricing rule for P1 is derived at the bill group level, whereas the effective pricing rule for P2 is derived from the parent customer level.

The system then derives the account with a particular invoice type (to which a price item must be billed) based on the priority which is defined for the respective price item in the pricing rule type. For example,



Price Item	Priority	Invoice Type	Account
P1	10	Standard	A1
	20	Retention	A2
P2	10	Retention	A2
	20	Standard	A1

### Example 2: Priority Based Account Derivation

In the example 2, while mapping the claim transaction to P1, the system checks whether an account where the **Invoice Type (C1INVTYP)** characteristic is set to **Standard** exists for the bill group. If so, it considers the standard account (A1) of the bill group for billing. However, if an account where the **Invoice Type (C1INVTYP)** characteristic is set to **Standard** does not exist for the bill group, the system checks whether an account where the **Invoice Type (C1INVTYP)** characteristic is set to **Retention** exists for the bill group. If so, it considers the retention account (A2) of the bill group for billing. If an account where the **Invoice Type (C1INVTYP)** characteristic is set to **Retention** does not exist for the bill group, the status of the transaction is changed to **Error**.

Similarly, while mapping the claim transaction to P2, the system considers the account of the bill group which is available based on the priority. The system derives the billing account for only those price items for which the effective pricing rule is derived.

**Note:** The characteristic type which indicates the type of account (for example, **C1INVTYP**) must be specified in the **Invoice Type Characteristic Type** option type of the **C1-ASOBLLNG** feature configuration. Otherwise, erroneous results might occur.

Once the account is derived, the system then checks whether the account has one active contract of the contract type which is associated with the price item. If so, it fetches the contract for further processing. Once the effective pricing rule, account, and active contract are derived, the transaction is mapped to the respective price item, price item parameters, and account. A transaction leg is created for each price item, price item parameters, and account combination. For example, if the claim transaction is mapped to the following price item and account combinations:

Price Item	Effective Pricing Rule	Account	Active Contract	Transaction Leg
P1	PR1	A1	C1	TL1
P2	PR2	A2	C2	TL2
P3	PR3	A3	C3	TL3

### Example 3: Transaction Leg Derivation

In the example 3, the system creates three transaction legs — TL1, TL2, and TL3 for the transaction. Once a transaction leg is created, the respective effective pricing rule is stamped against the transaction leg. Usually, once a transaction leg is created in the **Validate Transaction and Derive Price Item (C1-TXNIP)** batch, the price item parameters (for which the parameter usage is set to **Pricing**) of the transaction leg are grouped. The system does not support multiple parameter based pricing for the pricing rule types where the pricing rule type category is set to **Claim**. Therefore, when the price item parameters are not specified, the price item parameter group ID is set to 1 corresponding to each transaction leg — TL1, TL2, and TL3.

**Note:** A price item parameter group is used to determine the price item pricing. A unique group ID is generated for each group. If a group with a set of price item parameters already exists in the system, a new group is not created. Instead, the existing group is used for determining the price item pricing.

If a pricing group is used while defining a pricing rule for a bill group, the system fetches the pricing rule for a claim transaction only when the following conditions are met:

- The paid date of the claim transaction falls within the pricing rule's date range.

- The employee attributes specified in the claim transaction match the criteria defined in any one of the pricing group rule.

Let us understand this with the help of an example. A claim transaction is received with the following details:

- UDF\_CHAR\_1 is set to X
- UDF\_CHAR\_2 is set to Western
- UDF\_CHAR\_3 is set to Indian
- UDF\_CHAR\_4 is set to HR
- UDF\_CHAR\_5 is set to Permanent
- UDF\_DATE\_1 is set to 04-06-2018
- Transaction Record Type is set to TR1

Let us assume that the following pricing structure is defined in the system:

Transaction Record Type	Primary Pricing Rule Type	Price Item	Pricing Rule	Pricing Start Date	Pricing End Date	Pricing Group	Rule 1	Rule 2
TR1	CLAIM	PP1	PR1	01-01-2018	31-12-2018	PG1	Source System = X, Parameter 1 = Western, Parameter 2 = Indian, Parameter 3 = HR, and Parameter 4 = Permanent	Source System = X, Parameter 1 = Eastern, and Parameter 2 = Indian, Parameter 3 = HR, and Parameter 4 = Permanent

**Note:** Here, the source system is mapped to the **UDF\_CHAR\_1** field, the parameter 1 is mapped to the **UDF\_CHAR\_2** field, the parameter 2 is mapped to the **UDF\_CHAR\_3** field, the parameter 3 is mapped to the **UDF\_CHAR\_4** field, the parameter 4 is mapped to the **UDF\_CHAR\_5** field, and the paid date is mapped to the **UDF\_DATE\_1** field in the CLAIM pricing rule type.

#### Example 4: Effective Pricing Rule is Defined Using a Pricing Group

In the example 4, the system considers the PR1 pricing rule for PP1 because of the following reasons:

- The paid date (i.e. 04-06-2018) of the claim transaction falls within the PR1 pricing rule's date range (i.e. 01-01-2018 to 31-12-2018).
- The employee attributes specified in the claim transaction match the criteria defined in the Rule 1 (i.e. Source System = X, Location = Western, Nationality = Indian, Employee Department = HR, and Employee Status = Permanent)

The system then stores the pricing group rule which is satisfied against a parameter which is defined in the **Pricing Group Rule Parameter** option type of the **C1-ASOBLLNG** feature configuration. In the example 4, the price item parameter group is created and it contains the pricing group rule parameter. For example, Group A contains Pricing Group Rule Parameter = Rule 1.

In the example 4, the system could find the exact match for pricing parameters defined in the pricing group rule. However, if the exact match is not available, the system finds the effective pricing rule using the best fit match for the pricing parameters defined in the pricing group rule. Note that the system searches for the exact match in the effective pricing rules at both the bill group and parent customer levels. If the exact match is not available at both the levels, the system finds the effective pricing rule using the best fit match for the pricing parameters (defined in the pricing group rule) first at the bill group level and then at the parent customer level.

Let us understand this with the help of an example. A claim transaction is received with the following details:

- UDF\_CHAR\_1 is set to X
- UDF\_CHAR\_2 is set to Western
- UDF\_CHAR\_3 is set to Indian
- UDF\_CHAR\_4 is set to HR
- UDF\_CHAR\_5 is set to Permanent
- UDF\_DATE\_1 is set to 04-06-2018
- Transaction Record Type is set to TR2

Let us assume that the following pricing structure is defined in the system:

Transaction Record Type	Primary Pricing Rule Type	Price Item	Pricing Rule	Pricing Start Date	Pricing End Date	Pricing Group	Rule 1	Rule 2
TR2	CLM	PP1	PR1	01-01-2018	31-12-2018	PG1	Source System = X and Parameter 1 = Western	Source System = X and Parameter 1 = Eastern
		PP2	PR2	01-01-2018	31-12-2018	PG2	Source System = X, Parameter 1 = Eastern, Parameter 2 = Indian, Parameter 3 = HR, and Parameter 4 = Permanent	Source System = X, Parameter 1 = Western, Parameter 2 = Indian, Parameter 3 = HR, and Parameter 4 = Permanent

**Note:** Here, the source system is mapped to the **UDF\_CHAR\_1** field, the parameter 1 is mapped to the **UDF\_CHAR\_2** field, the parameter 2 is mapped to the **UDF\_CHAR\_3** field, the parameter 3 is mapped to the **UDF\_CHAR\_4** field, the parameter 4 is mapped to the **UDF\_CHAR\_5** field, and the paid date is mapped to the **UDF\_DATE\_1** field in the CLM pricing rule type.

#### Example 5: Effective Pricing Rule Derivation Using Best Fit Match for Pricing Parameters

In the example 5, the system could not find the exact match for the pricing parameters (i.e. Source System = X, Parameter 1 = Western, Parameter 2 = Indian, Parameter 3 = HR, and Parameter 4 = Permanent) in the effective pricing rule for PP1. Therefore, the system searches for the best fit match. While searching for the best fit match, the system rules out the optional parameter 4 (i.e. Parameter 4 = Permanent) and then checks whether the pricing group rule where Source System = X, Parameter 1 = Western, Parameter 2 = Indian, and Parameter 3 = HR exists in the effective pricing rule. If so, it considers PR1 as the effective pricing rule for PP1. If not, the system then rules out the optional parameter 3 (i.e. Parameter 3 = HR) and then checks whether the pricing group rule where Source System = X, Parameter 1 = Western, and Parameter 2 = Indian exists in the effective pricing rule. If so, it considers PR1 as the effective pricing rule for PP1. If not, the system then rules out the optional parameter 2 (i.e. Parameter 2 = Indian) and then checks whether the pricing group rule where Source System = X and Parameter 1 = Western exists in the effective pricing rule. If so, it considers PR1 as the effective pricing rule for PP1. If not, the status of the transaction is changed to **Error**.

In the example 5, the system considers Rule 1 where Source System = X and Parameter 1 = Western as the best fit match, and therefore fetches PR1 as the effective pricing rule for PP1. In addition, the system fetches PR2 as the effective pricing rule for PP2. The system creates two price item parameter groups — One contains Pricing Group Rule Parameter = Rule 1 and another contains Pricing Group Rule Parameter = Rule 2. Once the price item parameter group is created, the system creates the aggregation parameter group. An aggregation parameter group contains all price item parameters included in the pricing rule type for which the parameter usage is set to **Aggregation**.

**Note:** We recommend that you should only include the optional aggregation price item parameters in the pricing rule types where the pricing rule type category is set to **Claim**. Otherwise, erroneous results might occur.

If the effective pricing rule is not derived for a price item or if the account or active contract for the account is not derived, the system does not create a transaction leg for the respective price item. Let us understand this with the help of an example:

Price Item	Effective Pricing Rule	Account	Active Contract	Transaction Leg
PP1	-	-	-	-
PP2	PR2	-	-	-
PP3	PR3	A3	C3	TL1
PP4	-	-	-	-
PP5	PR5	A2	C1	TL2
PP6	PR6	A1	-	-

#### Example 6: No. of Transaction Legs Derived

In the example 6, the system could not find the effective pricing rule for PP1 and PP4, the required account for PP2, and the active contract for PP6 on A1. Therefore, in this case, the system creates two transaction legs — TL1 and TL2 for the claim transaction.

If the eligibility rule type is defined of a price item, the system maps the claim transaction to the price item only when the eligibility rule is satisfied. If the eligibility rule is not satisfied, the system does not consider the price item for billing. For example,

Price Item	Eligibility Criteria Met	Effective Pricing Rule	Account	Active Contract	Transaction Leg
PE1	Yes	PR1	A1	C1	TL1
PE2	-	PR2	-	-	-
PE3	No	-	-	-	-
PE4	Yes	-	-	-	-
PE5	Yes	PR3	A2	-	-
PE6	Yes	PR4	-	-	-

#### Example 7: Price Item Eligibility for Transaction Leg Derivation

In the example 7, the eligibility criteria was defined for PE1, PE3, PE4, PE5, and PE6. The eligibility criteria was satisfied for PE1, PE4, PE5, and PE6, but not for PE3. Further, the system could not find the effective pricing rule for PE4, the required account for PE2 and PE6, and the active contract for PE5 on A2. Therefore, in this case, the system creates one transaction leg (i.e. TL1) for the claim transaction. For more information, refer to the [Price Item Eligibility](#) on page 2726 section.

Once a transaction leg is created, the derivation date is set as the processing date corresponding to the transaction leg.

## Account and Price Item Derivation (for the Specific Stop-Loss and Aggregate Stop-Loss Pricing Rule Type Categories)

Once the **Validate Transaction and Derive Price Item (C1-TXNIP)** batch calls the primary pricing rule type specified in the transaction record type, it calls the related pricing rule types (if any) defined in the primary pricing rule type. Note that the related pricing rule types are called one by one in the specified sequence. Let us understand this with the help of an example.

Primary Pricing Rule Type	Sequence	Related Pricing Rule Type
CLAIM	10	SPECIFIC STOP-LOSS
	20	AGGREGATE STOP-LOSS

### Example 1: Related Pricing Rule Type Sequence

In the example 1, the system first calls the related pricing rule type with the highest sequence (i.e. 10) once the CLAIM pricing rule type is called. The system calls the related pricing rule type irrespective of whether the transaction legs are derived using the primary pricing rule type. Once the SPECIFIC STOP-LOSS pricing rule type is called, the system calls the related pricing rule type with the next sequence (i.e. 20). This process continues until all related pricing rule types defined in the primary pricing rule type are called one by one in the specified sequence.

If the eligibility rule type is defined for a related pricing rule type, the system considers the related pricing rule type for deriving the transaction legs only when the eligibility rule is satisfied. If the eligibility rule is not satisfied, the system does not consider the related pricing rule type for deriving the transaction legs. Let us understand this with the help of an example.

Primary Pricing Rule Type	Sequence	Related Pricing Rule Type	Eligibility Criteria Met
CLAIM	10	SPECIFIC STOP-LOSS	Yes
	20	AGGREGATE STOP-LOSS	No

### Example 2: Related Pricing Rule Type Eligibility Criteria

In the example 2, the eligibility criteria is defined for the SPECIFIC STOP-LOSS and AGGREGATE STOP-LOSS pricing rule types. However, the eligibility criteria for the AGGREGATE STOP-LOSS pricing rule type was not satisfied, and therefore it is not used for deriving the transaction legs.

The **Validate Transaction and Derive Price Item (C1-TXNIP)** batch maps a claim transaction to one or more price item and price item parameters which are defined in the eligible related pricing rule type. This is possible only when you attach an algorithm created using the **C1\_ACCPRISL** algorithm type to the **Account and Price Item Derivation** system event of the related pricing rule type.

**Note:** Ideally, the pricing rule types where the pricing rule type category is set to **Specific Stop-Loss** or **Aggregate Stop-Loss** should not have price item parameters for which the parameter usage is set to **Pricing**. This is because the system will not use these price item parameters while searching for an effective pricing rule for the respective price items.

This algorithm fetches an effective pricing rule for each price item specified in the related pricing rule type. It searches for an effective pricing rule for a price item at the bill group level. It derives an effective pricing rule for each price item using the incurred and paid dates specified in the claim transaction. It fetches an effective pricing rule where the following conditions are met:

- The incurred and paid dates of the claim transaction fall within the incurred and paid date ranges defined in the parent accumulation group (which is derived through the parent customer's pricing rule).
- A transaction leg is already created for at least one price item and price item parameters combination which is specified in the accumulation criteria.

For run-in claim transactions, this algorithm fetches an effective pricing rule where the following conditions are met:

- The run-in incurred and paid dates of the claim transaction fall within the run-in incurred and paid date ranges defined in the run-in accumulation group (which is derived through the parent customer's pricing rule).
- The effective pricing rule exists for at least one price item and price item parameters combination which is specified in the accumulation criteria.

For example, if the system receives a claim transaction with the following details:

- UDF\_CHAR\_1 is set to Western
- UDF\_CHAR\_2 is set to BG1
- UDF\_DATE\_1 is set to 18-02-2018
- UDF\_DATE\_2 is set to 28-02-2018
- Transaction Record Type is set to TR1

Let us assume that the following pricing structure is defined in the system:

Transaction Record Type	Primary Pricing Rule Type	Related Pricing Rule Type	Price Item in Related Pricing Rule Type	Pricing Rule	Incurred Date Range in Associated Parent Customer's Pricing Rule	Paid Date Range in Associated Parent Customer's Pricing Rule	Accumulation Criteria
					(i.e. in Parent Accumulation Group)		
TR1	CLAIM	SPECIFIC STOP-LOSS	S1	C1S1	01-01-2017 - 31-12-2017	01-01-2017 - 28-02-2018	Price Item: CLAIM, Price Item Parameters: Location = Western, Employee Group = BG1
				C2S1	01-01-2018 - 31-12-2018	01-01-2018 - 28-02-2019	Price Item: CLAIM, Price Item Parameters: Location = Western, Employee Group = BG1
							Price Item: CLM, Price Item Parameters: Location = Western, Employee Group = BG1
			S2	C1S2	01-01-2017 - 31-12-2017	01-01-2017 - 28-02-2018	Price Item: CLM, Price Item Parameters: Location = Western, Employee Group = BG1

Transaction Record Type	Primary Pricing Rule Type	Related Pricing Rule Type	Price Item in Related Pricing Rule Type	Pricing Rule	Incurred Date Range in Associated Parent Customer's Pricing Rule	Paid Date Range in Associated Parent Customer's Pricing Rule	Accumulation Criteria
					(i.e. in Parent Accumulation Group)		
				C2S2	01-01-2018 - 31-12-2018	01-01-2018 - 28-02-2019	Price Item: CLM, Price Item Parameters: Location = Western, Employee Group = BG1

**Note:**

Price Item in Primary Pricing Rule Type: CLM; Price Item Parameters in Primary Pricing Rule Type where the Eligible for Stop-Loss option is selected: Location = UDF\_CHAR\_1 and Employee Group = UDF\_CHAR\_2.

Here, the incurred date is mapped to the **UDF\_DATE\_1** field and the paid date is mapped to the **UDF\_DATE\_2** field in the CLAIM pricing rule type.

**Example 3: SSL and ASL Effective Pricing Rule Derivation for Claim Transaction**

In the example 3, the system fetches the C2S1 and C2S2 pricing rules for S1 and S2, respectively, because of the following reasons:

- Incurred date mentioned in the claim transaction falls within the incurred date range (i.e. 01-01-2018 - 31-12-2018) defined in the parent accumulation group.
- Paid date mentioned in the claim transaction falls within the paid date range (i.e. 01-01-2018 - 28-02-2019) defined in the parent accumulation group.
- A transaction leg already exists for the following price item and price item parameters combination which is specified in the accumulation criteria of the C2S1 and C2S2 pricing rules:
  - Price Item: CLM, Price Item Parameters: Location = Western and Employee Group = BG1

Let us take another example where the system receives a run-in claim transaction with the following details:

- UDF\_CHAR\_1 is set to Eastern
- UDF\_CHAR\_3 is set to Active
- UDF\_DATE\_3 is set to 18-06-2017
- UDF\_DATE\_4 is set to 01-07-2017
- Transaction Record Type is set to TR2

Let us assume that the following pricing structure is defined in the system:

Transaction Record Type	Primary Pricing Rule Type	Related Pricing Rule Type	Price Item in Related Pricing Rule Type	Pricing Rule	Run-in Incurred Date Range in Associated Parent Customer's Pricing Rule	Run-in Paid Date Range in Associated Parent Customer's Pricing Rule	Accumulation Criteria
					(i.e. in Run-in Accumulation Group)		
TR2	CLAIM	AGGREGATE STOP-LOSS	AS1	C1AS1	01-01-2017 - 31-12-2017	01-01-2017 - 28-02-2018	Price Item: CLAIM, Price Item Parameters: Location = Eastern, Employee Status = Active
				C2AS1	01-01-2018 - 31-12-2018	01-01-2018 - 28-02-2019	Price Item: CLAIM, Price Item Parameters: Location = Eastern, Employee Status = Active
			AS2	C1AS2	01-01-2017 - 31-12-2017	01-01-2017 - 28-02-2018	Price Item: CLM, Price Item Parameters: Location = Eastern, Employee Status = Active
				C2AS2	01-01-2018 - 31-12-2018	01-01-2018 - 28-02-2019	Price Item: CLM, Price Item Parameters: Location = Eastern, Employee Status = Active

**Note:**

Price Items in Primary Pricing Rule Type: CLAIM and CLM; Price Item Parameters in Primary Pricing Rule Type where the Eligible for Stop-Loss option is selected: Location = UDF\_CHAR\_1 and Employee Status = UDF\_CHAR\_3. Here, the run-in incurred date is mapped to the UDF\_DATE\_3 field and the run-in paid date is mapped to the UDF\_DATE\_4 field in the CLAIM pricing rule type.

**Example 4: SSL and ASL Effective Pricing Rule Derivation for Run-in Claim Transaction**

In the example 4, the system fetches the C1AS1 and C1AS2 pricing rules for AS1 and AS2, respectively, because of the following reasons:



- Run-in incurred date mentioned in the claim transaction falls within the run-in incurred date range (i.e. 01-01-2017 - 31-12-2017) defined in the run-in accumulation group.
- Run-in paid date mentioned in the claim transaction falls within the run-in paid date range (i.e. 01-01-2017 - 28-02-2018) defined in the run-in accumulation group.
- An effective pricing rule exists for the following price item and price item parameters combination which is specified in the accumulation criteria of the C1AS1 and C1AS2 pricing rules:
  - Price Item: CLAIM, Price Item Parameters: Location = Eastern, Employee Status = Active
  - Price Item: CLM, Price Item Parameters: Location = Eastern, Employee Status = Active

The system then checks whether the ASSL Credit Account (in case of specific stop-loss pricing rule) and ASL Credit Account (in case of aggregate stop-loss pricing rule) is specified in the associated parent customer's pricing rule. If so, the system considers the respective account for billing. Otherwise, the system derives the account with a particular invoice type (to which a price item must be billed) based on the priority which is defined for the respective price item in the related pricing rule type. For example,

Related Pricing Rule Type	Price Item	Priority	Invoice Type	Account
SPECIFIC STOP-LOSS	S1	10	Standard	A1
		20	Retention	A2
	S2	10	Retention	A2
		20	Standard	A1

#### Example 5: Priority Based Account Derivation

In the example 5, while mapping the claim transaction to S1, the system checks whether an account where the **Invoice Type (C1INVTYP)** characteristic is set to **Standard** exists for the bill group. If so, it considers the standard account (A1) of the bill group for billing. However, if an account where the **Invoice Type (C1INVTYP)** characteristic is set to **Standard** does not exist for the bill group, the system checks whether an account where the **Invoice Type (C1INVTYP)** characteristic is set to **Retention** exists for the bill group. If so, it considers the retention account (A2) of the bill group for billing. If an account where the **Invoice Type (C1INVTYP)** characteristic is set to **Retention** does not exist for the bill group, the status of the transaction is changed to **Error**.

Similarly, while mapping the claim transaction to S2, the system considers the account of the bill group which is available based on the priority. The system derives the billing account for only those price items for which the effective pricing rule is derived.

**Note:** The characteristic type which indicates the type of account (for example, **C1INVTYP**) must be specified in the **Invoice Type Characteristic Type** option type of the **C1-ASOBLLNG** feature configuration. Otherwise, erroneous results might occur.

Once the account is derived, the system then checks whether the account has one active contract of the contract type which is associated with the price item. If so, it fetches the contract for further processing. Once the effective pricing rule, account, and active contract are derived, the transaction is mapped to the respective price item, price item parameters, and account. A transaction leg is created for each price item, price item parameters, and account combination. For example, if the claim transaction is mapped to the following price item and account combinations:

Transaction Record Type	Primary Pricing Rule Type	Related Pricing Rule Type	Price Item in Related Pricing Rule Type	Effective Pricing Rule	Account	Active Contract	Transaction Leg
TR1	CLAIM	SPECIFIC STOP-LOSS	S3	PRS3	A1	C3	TL3
			S4	PRS4	A2	C4	TL4

#### Example 6: Transaction Leg Derivation

In the example 6, the system creates two transaction legs — TL3 and TL4 for the claim transaction. Once a transaction leg is created, the respective effective pricing rule is stamped against the transaction leg. Usually, once a transaction leg is created in the **Validate Transaction and Derive Price Item (C1-TXNIP)** batch, the price item parameters (for which the parameter usage is set to **Pricing**) of the transaction leg are grouped. The system does not support multiple parameter based pricing for the pricing rule types where the pricing rule type category is set to **Specific Stop-Loss** and **Aggregate Stop-Loss**. Therefore, when the price item parameters are not specified, the price item parameter group ID is set to 1 corresponding to each transaction leg — TL3 and TL4.

**Note:** A price item parameter group is used to determine the price item pricing. A unique group ID is generated for each group. If a group with a set of price item parameters already exists in the system, a new group is not created. Instead, the existing group is used for determining the price item pricing.

If a pricing group is used while defining a pricing rule for a bill group, the system fetches the pricing rule for a claim transaction only when the following conditions are met:

- The incurred and paid dates of the claim transaction fall within the incurred and paid date ranges defined in the parent accumulation group (which is derived through the parent customer's pricing rule).
- A transaction leg is already created for at least one price item and price item parameters combination which is specified in the accumulation criteria.
- The employee attributes specified in the claim transaction match the criteria defined in any one of the pricing group rule.

Similarly, the system will fetch the pricing rule for a run-in claim transaction only when the following conditions are met:

- The run-in incurred and paid dates of the claim transaction fall within the run-in incurred and paid date ranges defined in the run-in accumulation group (which is derived through the parent customer's pricing rule).
- The effective pricing rule exists for at least one price item and price item parameters combination which is specified in the accumulation criteria.
- The employee attributes specified in the run-in claim transaction match the criteria defined in any one of the pricing group rule.

Let us understand this with the help of an example. A claim transaction is received with the following details:

- UDF\_CHAR\_1 is set to X
- UDF\_CHAR\_2 is set to Western
- UDF\_CHAR\_3 is set to Indian
- UDF\_CHAR\_4 is set to HR
- UDF\_CHAR\_5 is set to Permanent
- UDF\_CHAR\_6 is set to Senior Manager
- UDF\_CHAR\_7 is set to BG1
- UDF\_DATE\_1 is set to 31-12-2018

- UDF\_DATE\_2 is set to 28-02-2019
- Transaction Record Type is set to TR1

Transaction Record Type	Primary Pricing Rule Type	Related Pricing Rule Type	Price Item in Related Pricing Rule Type	Pricing Rule	Incurred Date Range in Associated Parent Customer's Pricing Rule	Paid Date Range in Associated Parent Customer's Pricing Rule	Pricing Group	Pricing Group Rule	Accumulation Criteria
					(i.e. in Parent Accumulation Group)				
TR1	CLAIM	SPECIFIC STOP-LOSS	S1	PR1	01-01-2018 - 31-12-2018	01-01-2018 - 28-02-2019	PG1	Rule 1 (where Source System = X, Parameter 1 = Western, Parameter 2 = Indian, Parameter 3 = HR, and Parameter 4 = Permanent)	Price Item: CLM; Price Item Parameters: Designation = Senior Manager and Employee Group = BG1
								Rule 1 (where Source System = X, Parameter 1 = Western, Parameter 2 = Indian, Parameter 3 = HR, and Parameter 4 = Permanent)	Price Item: CLM; Price Item Parameters: Designation = Senior Manager and Employee Group = BG2

Transaction Record Type	Primary Pricing Rule Type	Related Pricing Rule Type	Price Item in Related Pricing Rule Type	Pricing Rule	Incurred Date Range in Associated Parent Customer's Pricing Rule	Paid Date Range in Associated Parent Customer's Pricing Rule	Pricing Group	Pricing Group Rule	Accumulation Criteria
					(i.e. in Parent Accumulation Group)				
								Rule 2 (where Source System = X, Parameter 1 = Eastern, and Parameter 2 = Indian, Parameter 3 = HR, and Parameter 4 = Permanent)	Price Item: CLM; Price Item Parameters: Designation = Senior Manager and Employee Group = BG1
								Rule 2 (where Source System = X, Parameter 1 = Eastern, and Parameter 2 = Indian, Parameter 3 = HR, and Parameter 4 = Permanent)	Price Item: CLM; Price Item Parameters: Designation = Senior Manager and Employee Group = BG2

**Note:**

Price Item in Primary Pricing Rule Type: CLM; Price Item Parameters in Primary Pricing Rule Type where the Eligible for Stop-Loss option is selected: Designation = UDF\_CHAR\_6 and Employee Group = UDF\_CHAR\_7.

Here, the source system is mapped to the **UDF\_CHAR\_1** field, the parameter 1 is mapped to the **UDF\_CHAR\_2** field, the parameter 2 is mapped to the **UDF\_CHAR\_3** field, the parameter 3 is mapped to the **UDF\_CHAR\_4** field, the parameter 4 is mapped to the **UDF\_CHAR\_5** field, the incurred date is mapped to the **UDF\_DATE\_1** field, and the paid date is mapped to the **UDF\_DATE\_2** field in the CLAIM pricing rule type.

**Example 7: Effective Pricing Rule is Defined Using a Pricing Group**

In the example 7, the system considers the PR1 pricing rule for S1 because of the following reasons:

- Incurred date mentioned in the claim transaction falls within the incurred date range (i.e. 01-01-2018 - 31-12-2018) defined in the parent accumulation group.
- Paid date mentioned in the claim transaction falls within the paid date range (i.e. 01-01-2018 - 28-02-2019) defined in the parent accumulation group.
- The employee attributes specified in the claim transaction match the criteria defined in the Rule 1 (i.e. Source System = X, Parameter 1 = Western, Parameter 2 = Indian, Parameter 3 = HR, and Parameter 4 = Permanent).
- A transaction leg already exists for the following price item and price item parameters combination which is specified in the accumulation criteria of the PR1 pricing rule:
  - Price Item: CLM; Price Item Parameters: Designation = Senior Manager and Employee Group = BG1

The system then stores the pricing group rule which is satisfied against a parameter which is defined in the **Pricing Group Rule Parameter** option type of the **C1-ASOBLLNG** feature configuration. In the example 7, the price item parameter group is created and it contains the pricing group rule parameter. For example, Group A contains Pricing Group Rule Parameter = Rule 1.

In the example 7, the system could find the exact match for pricing parameters defined in the pricing group rule. However, if the exact match is not available, the system finds the effective pricing rule using the best fit match for the pricing parameters defined in the pricing group rule. Let us understand this with the help of an example. A claim transaction is received with the following details:

- UDF\_CHAR\_1 is set to X
- UDF\_CHAR\_2 is set to Western
- UDF\_CHAR\_3 is set to Indian
- UDF\_CHAR\_4 is set to HR
- UDF\_CHAR\_5 is set to Permanent
- UDF\_CHAR\_6 is set to Senior Manager
- UDF\_CHAR\_7 is set to BG1
- UDF\_DATE\_1 is set to 06-06-2018
- UDF\_DATE\_2 is set to 27-06-2018
- Transaction Record Type is set to TR2

Let us assume that the following pricing structure is defined in the system:

Transaction Record Type	Primary Pricing Rule Type	Related Pricing Rule Type	Price Item in Related Pricing Rule Type	Pricing Rule	Incurred Date Range in Associated Parent Customer's Pricing Rule	Paid Date Range in Associated Parent Customer's Pricing Rule	Pricing Group	Pricing Group Rule	Accumulation Criteria
					(i.e. in Parent Accumulation Group)				
TR2	CLAIM	SPECIFIC STOP-LOSS	S1	PR1	01-01-2018 - 31-12-2018	01-01-2018 - 28-02-2019	PG1	Rule 1 (where Source System = X and Parameter 1 = Western)	Price Item: CLAIM; Price Item Parameters: Designation = Senior Manager; Employee Group = BG1
								Rule 1 (where Source System = X and Parameter 1 = Western)	Price Item: CLAIM; Price Item Parameters: Designation = Senior Manager; Employee Group = BG2
								Rule 2 (where Source System = X and Parameter 1 = Eastern)	Price Item: CLAIM; Price Item Parameters: Designation = Senior Manager; Employee Group = BG1
								Rule 2 (where Source System = X and Parameter 1 = Eastern)	Price Item: CLAIM; Price Item Parameters: Designation = Senior Manager; Employee Group = BG2

Transaction Record Type	Primary Pricing Rule Type	Related Pricing Rule Type	Price Item in Related Pricing Rule Type	Pricing Rule	Incurred Date Range in Associated Parent Customer's Pricing Rule	Paid Date Range in Associated Parent Customer's Pricing Rule	Pricing Group	Pricing Group Rule	Accumulation Criteria
					(i.e. in Parent Accumulation Group)				
			S2	PR2	01-01-2018 - 31-12-2018	01-01-2018 - 28-02-2019	PG2	<p>Rule 1 (where Source System = X, Parameter 1 = Eastern, Parameter 2 = Indian, Parameter 3 = HR, and Parameter 4 = Permanent)</p> <p>Rule 1 (where Source System = X, Parameter 1 = Eastern, Parameter 2 = Indian, Parameter 3 = HR, and Parameter 4 = Permanent)</p> <p>Rule 2 (where Source System = X, Parameter 1 = Western, Parameter 2 = Indian, Parameter 3 = HR, and Parameter 4 = Permanent)</p>	<p>Price Item: CLAIM; Price Item Parameters: Designation = Senior Manager; Employee Group = BG2</p> <p>Price Item: CLAIM; Price Item Parameters: Designation = Senior Manager; Employee Group = BG1</p> <p>Price Item: CLAIM; Price Item Parameters: Designation = Senior Manager; Employee Group = BG2</p>

Transaction Record Type	Primary Pricing Rule Type	Related Pricing Rule Type	Price Item in Related Pricing Rule Type	Pricing Rule	Incurred Date Range in Associated Parent Customer's Pricing Rule	Paid Date Range in Associated Parent Customer's Pricing Rule	Pricing Group	Pricing Group Rule	Accumulation Criteria
					(i.e. in Parent Accumulation Group)				
								Rule 2 (where Source System = X, Parameter 1 = Western, Parameter 2 = Indian, Parameter 3 = HR, and Parameter 4 = Permanent)	Price Item: CLAIM; Price Item Parameters: Designation = Senior Manager; Employee Group = BG1

**Note:**

Price Item in Primary Pricing Rule Type: CLAIM; Price Item Parameters in Primary Pricing Rule Type where the Eligible for Stop-Loss option is selected: Designation = UDF\_CHAR\_6 and Employee Group = UDF\_CHAR\_7.

Here, the source system is mapped to the **UDF\_CHAR\_1** field, the parameter 1 is mapped to the **UDF\_CHAR\_2** field, the parameter 2 is mapped to the **UDF\_CHAR\_3** field, the parameter 3 is mapped to the **UDF\_CHAR\_4** field, the parameter 4 is mapped to the **UDF\_CHAR\_5** field, the incurred date is mapped to the **UDF\_DATE\_1** field, and the paid date is mapped to the **UDF\_DATE\_2** field in the CLAIM pricing rule type.

**Example 8: Effective Pricing Rule Derivation Using Best Fit Match for Pricing Parameters**

In the example 8, the system could not find the exact match for the pricing parameters (i.e. Source System = X, Parameter 1 = Western, Parameter 2 = Indian, Parameter 3 = HR, and Parameter 4 = Permanent) in the effective pricing rule for S1. Therefore, the system searches for the best fit match. While searching for the best fit match, the system rules out the optional parameter 4 (i.e. Parameter 4 = Permanent) and then checks whether the pricing group rule where Source System = X, Parameter 1 = Western, Parameter 2 = Indian, and Parameter 3 = HR exists in the effective pricing rule. If so, it considers the pricing group rule for further processing. If not, the system then rules out the optional parameter 3 (i.e. Parameter 3 = HR) and then checks whether the pricing group rule where Source System = X, Parameter 1 = Western, and Parameter 2 = Indian exists in the effective pricing rule. If so, it considers the pricing group rule for further processing. If not, the system then rules out the optional parameter 2 (i.e. Parameter 2 = Indian) and then checks whether the pricing group rule where Source System = X and Parameter 1 = Western exists in the effective pricing rule. If so, it considers the pricing group rule for further processing. If not, the status of the transaction is changed to **Error**.

In the example 8, the system considers Rule 1 where Source System = X and Parameter 1 = Western as the best fit match in the PR1 pricing rule for S1. In addition, a transaction leg already exists for the following price item and price item parameters combination which is specified in the accumulation criteria of the PR1 pricing rule:

- Price Item: CLAIM; Price Item Parameters: Designation = Senior Manager; Employee Group = BG1

Therefore, the system fetches PR1 as the effective pricing rule for S1. In addition, the system fetches PR2 as the effective pricing rule for S2. The system creates two price item parameter groups — One contains Pricing Group Rule Parameter = Rule 1 and another contains Pricing Group Rule Parameter = Rule 2. Once the price item parameter group is created,



the system creates the aggregation parameter group. An aggregation parameter group contains all price item parameters included in the related pricing rule type for which the parameter usage is set to **Aggregation**.

If the effective pricing rule is not derived for a price item or if the account or active contract for the account is not derived, the system does not create a transaction leg for the respective price item. Let us understand this with the help of an example:

Related Pricing Rule Type	Price Item	Effective Pricing Rule	Account	Active Contract	Transaction Leg
AGGREGATE STOP-LOSS	AS11	-	-	-	-
	AS12	PR12	A1	C1	TL11
	AS13	PR13	-	-	-
	AS14	PR14	A2	-	-
	AS15	PR15	-	-	-
	AS16	-	-	-	-
	AS17	PR17	A2	C2	TL12

#### Example 9: No. of Transaction Legs Derived

In the example 9, the system could not find the effective pricing rule for AS11 and AS16, the required account for AS13 and AS15, and the active contract for AS14 on A2. Therefore, in this case, the system creates two transaction legs — TL11 and TL12 for the transaction.

If the eligibility rule type is defined for a price item, the system maps the transaction to the price item only when the eligibility rule is satisfied. If the eligibility rule is not satisfied, the system does not consider the price item for billing. For example,

Sequence	Related Pricing Rule Type	Rule Type Eligibility Criteria Met	Price Item	Price Item Eligibility Criteria Met	Effective Pricing Rule	Account	Active Contract	Transaction Leg
10	SPECIFIC STOP-LOSS	Yes	SS1	Yes	PR1	A1	C1	TL1
			SS2	-	PR2	A2	C2	TL2
			SS3	No	-	-	-	-
20	AGGREGATE STOP-LOSS	No	AS4	-	-	-	-	-
			AS5	-	-	-	-	-
			AS6	-	-	-	-	-

#### Example 10: Price Item Eligibility for Transaction Leg Derivation

In the example 10, the eligibility criteria is defined for the SPECIFIC STOP-LOSS and AGGREGATE STOP-LOSS pricing rule types. However, the eligibility criteria for the AGGREGATE STOP-LOSS pricing rule type was not satisfied, and therefore it is not used for deriving the transaction legs. The eligibility criteria for SS1 was satisfied, but the eligibility criteria for SS3 was not satisfied. Therefore, in this case, the system creates two transaction legs (i.e. TL1 and TL2) for the claim transaction. For more information about the related pricing rule type eligibility and price item eligibility features, refer to the [Related Pricing Rule Type Eligibility](#) on page 2724 and [Price Item Eligibility](#) on page 2726 sections, respectively.

Once a transaction leg is created, the effective pricing rule's start date is set as the processing date corresponding to the transaction leg.

## Account and Price Item Derivation (for the Retention Type Claim Based Pricing Rule Type Category)

Once the **Validate Transaction and Derive Price Item (C1-TXNIP)** batch calls the primary pricing rule type specified in the transaction record type, it calls the related pricing rule types (if any) defined in the primary pricing rule type. Note that the related pricing rule types are called one by one in the specified sequence. Let us understand this with the help of an example.

Primary Pricing Rule Type	Sequence	Related Pricing Rule Type
CLAIM	10	RETENTION TYPE CLAIM BASED
	20	SPECIFIC STOP-LOSS
	30	AGGREGATE STOP-LOSS

### Example 1: Related Pricing Rule Type Sequence

In the example 1, the system first calls the related pricing rule type with the highest sequence (i.e. 10) once the CLAIM pricing rule type is called. The system calls the related pricing rule type irrespective of whether the transaction legs are derived using the primary pricing rule type. Once the RETENTION TYPE CLAIM BASED pricing rule type is called, the system calls the related pricing rule type with the next sequence (i.e. 20). This process continues until all related pricing rule types defined in the primary pricing rule type are called one by one in the specified sequence.

If the eligibility rule type is defined for a related pricing rule type, the system considers the related pricing rule type for deriving the transaction legs only when the eligibility rule is satisfied. If the eligibility rule is not satisfied, the system does not consider the related pricing rule type for deriving the transaction legs. Let us understand this with the help of an example.

Primary Pricing Rule Type	Sequence	Related Pricing Rule Type	Eligibility Criteria Met
CLAIM	10	RETENTION TYPE CLAIM BASED	Yes
	20	CLAIM BASED FEES	-
	30	CLAIM FEE CHARGES	No

### Example 2: Related Pricing Rule Type Eligibility Criteria

In the example 2, the eligibility criteria is defined for the RETENTION TYPE CLAIM BASED and CLAIM FEE CHARGES pricing rule types. However, the eligibility criteria for the CLAIM FEE CHARGES pricing rule type was not satisfied, and therefore it is not used for deriving the transaction legs.

The **Validate Transaction and Derive Price Item (C1-TXNIP)** batch maps a claim transaction to one or more price item and price item parameters which are defined in the eligible related pricing rule type. This is possible only when you attach an algorithm created using the **C1\_ACCPRIDRV** algorithm type to the **Account and Price Item Derivation** system event of the related pricing rule type.

This algorithm fetches the effective pricing rule for each price item and price item parameters combination specified in the related pricing rule type on the derivation date. The system considers the paid date as the derivation date. This algorithm first searches for the effective pricing rule for a price item and price item parameters combination which is defined for the policy at the bill group level. If the system does not find any effective pricing rule for a price item and price item parameters combination which is defined for the policy at the bill group level, it inherits the effective pricing rule for a price item and price item parameters combination from the parent customer level.

For example, if the system receives a claim transaction with the following details:

- UDF\_DATE\_1 is set to 15-01-2018
- Transaction Record Type is set to TR1

Let us assume that the following pricing structure is defined in the system:

Transaction Record Type	Primary Pricing Rule Type	Related Pricing Rule Type	Price Item in Related Pricing Rule Type	Pricing Rule	Pricing Start Date	Pricing End Date	Assignment Level
TR1	CLAIM	RETENTION TYPE CLAIM BASED	P3	C1P3	01-01-2018	31-12-2018	Parent Customer
				C2P3	01-01-2018	31-12-2018	Bill Group
			P4	C1P4	01-01-2018	31-12-2018	Parent Customer
				C2P4	01-01-2019	30-06-2019	Bill Group

**Note:** Here, the paid date is mapped to the UDF\_DATE\_1 field in the CLAIM pricing rule type.

### Example 3: Effective Pricing Rule Derivation

In the example 3, the system fetches C2P3 and C1P4 pricing rules for P3 and P4 respectively, which are effective on the paid date. Note that the effective pricing rule for P3 is derived at the bill group level, whereas the effective pricing rule for P4 is derived from the parent customer level.

While fetching the effective pricing rule, the system first searches for the exact match for the price item parameters at both the levels. For example, if the system receives a claim transaction with the following details:

- UDF\_CHAR\_1 is set to Western
- UDF\_CHAR\_2 is set to Active
- UDF\_DATE\_1 is set to 20-03-2018
- Transaction Record Type is set to TR4

Let us assume that the following pricing structure is defined in the system:

Transaction Record Type	Primary Pricing Rule Type	Related Pricing Rule Type	Price Item in Related Pricing Rule Type	Price Item Parameters in Related Pricing Rule Type	Pricing Rule	Pricing Start Date	Pricing End Date	Price Item Parameters in Pricing Rule	Fees	Assignment Level
TR4	CLAIM	CLAIM BASED CHARGES	P1	Location = UDF_CHAR_1 and Employee Status = UDF_CHAR_2	C1P1	01-01-2018	31-12-2018	Location = Western and Employee Status = Active	\$10	Parent Customer
								Location = Eastern and Employee Status = Active	\$12	

Transaction Record Type	Primary Pricing Rule Type	Related Pricing Rule Type	Price Item in Related Pricing Rule Type	Price Item Parameters in Related Pricing Rule Type	Pricing Rule	Pricing Start Date	Pricing End Date	Price Item Parameters in Pricing Rule	Fees	Assignment Level
								Location = Eastern and Employee Status = Retired	\$11	
								Location = Western and Employee Status = Retired	\$9	
					C2P1	01-01-2018	31-12-2018	Location = Western and Employee Status = Active	\$8	Bill Group
								Location = Eastern and Employee Status = Active	\$9	
								Location = Eastern and Employee Status = Retired	\$10	
								Location = Western and Employee Status = Retired	\$9	

**Note:** Here, the paid date is mapped to the UDF\_DATE\_1 field in the CLAIM pricing rule type.

#### Example 4: Exact Match for Price Item Parameters

In the example 4, the system fetches the C2P1 pricing rule for P1 because of the following reasons:

- The paid date (i.e. 20-03-2018) of the claim transaction falls within the date range (i.e. 01-01-2018 to 31-12-2018) of the C2P1 pricing rule which is defined at the bill group level.
- It contains the exact match for the price item parameters which are received in the transaction.

If the system cannot find the exact match for the price item parameters at both the levels, it searches for the best fit match for the price item parameters first at the bill group level and then at the parent customer level. For example, if the system receives a claim transaction with the following details:

- UDF\_CHAR\_1 is set to Western
- UDF\_CHAR\_2 is set to Active
- UDF\_CHAR\_3 is set to HR
- UDF\_CHAR\_4 is set to Indian
- UDF\_DATE\_1 is set to 07-06-2018
- Transaction Record Type is set to TR5

Let us assume that the following pricing structure is defined in the system:

Transaction Record Type	Primary Pricing Rule Type	Related Pricing Rule Type	Price Item in Related Pricing Rule Type	Price Item Parameters in Related Pricing Rule Type	Pricing Rule	Pricing Start Date	Pricing End Date	Price Item Parameters in Pricing Rule	Fees	Assignment Level
TR5	CLAIM	RETENTION CLAIM BASED FEES	P3	Location = UDF_CHAR_1, Employee Status = UDF_CHAR_2, Employee Department = UDF_CHAR_3, and Nationality = UDF_CHAR_4	C1P3	01-01-2018	31-12-2018	Location = Western and Employee Status = Active	\$10	Bill Group
								Location = Eastern and Employee Status = Active	\$12	
								Location = Eastern and Employee Status = Retired	\$11	
								Location = Western and Employee Status = Retired	\$9	

**Note:** Here, the paid date is mapped to the **UDF\_DATE\_1** field in the CLAIM pricing rule type.

#### Example 5: Best Fit Match for Price Item Parameters

**Note:** The **Location** and **Employee Status** parameters are mandatory for P3. However, the **Employee Department** and **Nationality** parameters are optional with the priority set to 1 and 2, respectively.

In the example 5, the system could not find the exact match for the price item parameters (i.e. Location = Western, Employee Status = Active, Employee Department = HR, and Nationality = Indian) in the effective pricing rule for P3. Therefore, the system searches for the best fit match. While searching for the best fit match, the system rules out the optional parameter with lowest priority (i.e. Nationality = Indian) and checks whether pricing is defined for the price item parameters (i.e. Location = Western, Employee Status = Active, and Employee Department = HR) in the effective pricing rule. If so, it considers C1P3 as the effective pricing rule for P3. If not, the system rules out the optional parameter with the next lowest priority (i.e. Employee Department = HR) and checks whether pricing is defined for the price item parameters (i.e. Location = Western and Employee Status = Active) in the effective pricing rule. If so, it considers C1P3 as the effective pricing rule for P3. If not, the status of the transaction is changed to **Error**.

In the example 5, the system considers pricing defined for the price item parameters (i.e. Location = Western and Employee Status = Active) as the best fit match, and therefore fetches C1P3 as the effective pricing rule for P3. While fetching the effective pricing rule, the system considers only those price item parameters specified in the related pricing rule type for which the parameter usage is set to **Pricing**.

The system then derives the account with a particular invoice type (to which a price item must be billed) based on the priority which is defined for the respective price item in the related pricing rule type. For example,

Related Pricing Rule Type	Price Item	Priority	Invoice Type	Account
RETENTION TYPE CLAIM BASED	P3	10	Standard	A1
	P4	10	Retention	A2
		20	Standard	A1

#### Example 6: Priority Based Account Derivation

In the example 6, while mapping the claim transaction to P3, the system checks whether an account where the **Invoice Type (C1INVTYP)** characteristic is set to **Standard** exists for the bill group. If so, it considers the standard account (A1) of the bill group for billing. However, if an account where the **Invoice Type (C1INVTYP)** characteristic is set to **Standard** does not exist for the bill group, the status of the transaction is changed to **Error**.

Similarly, while mapping the claim transaction to P4, the system checks whether an account where the **Invoice Type (C1INVTYP)** characteristic is set to **Retention** exists for the bill group. If so, it considers the retention account (A2) of the bill group for billing. However, if an account where the **Invoice Type (C1INVTYP)** characteristic is set to **Retention** does not exist for the bill group, the system checks whether an account where the **Invoice Type (C1INVTYP)** characteristic is set to **Standard** exists for the bill group. If so, it considers the standard account (A1) of the bill group for billing. If an account where the **Invoice Type (C1INVTYP)** characteristic is set to **Standard** does not exist for the bill group, the status of the transaction is changed to **Error**.

**Note:** The characteristic type which indicates the type of account (for example, **C1INVTYP**) must be specified in the **Invoice Type Characteristic Type** option type of the **C1-ASOBLLNG** feature configuration. Otherwise, erroneous results might occur.

Once the account is derived, the system then checks whether the account has one active contract of the contract type which is associated with the price item. If so, it fetches the contract for further processing. Once the effective pricing rule, account, and active contract are derived, the transaction is mapped to the respective price item, price item parameters, and account. A transaction leg is created for each price item, price item parameters, and account combination. For example, if the system receives a claim transaction with the following details:

- UDF\_CHAR\_1 is set to Western
- UDF\_CHAR\_2 is set to Active
- UDF\_CHAR\_3 is set to HR
- UDF\_DATE\_1 is set to 03-01-2018
- Transaction Record Type is set to TR5

Let us assume that the claim transaction is mapped to the following price item, price item parameters, and account combinations:

Transaction Record Type	Primary Pricing Rule Type	Related Pricing Rule Type	Price Item in Related Pricing Rule Type	Price Item Parameters in Related Pricing Rule Type	Effective Pricing Rule	Best Fit Match for Price Item Parameters in Effective Pricing Rule	Account	Active Contract	Transaction Leg
TR5	CLAIM	CLAIM BASED FEES	P1	Location = UDF_CHAR_1, Employee Status = UDF_CHAR_2, Employee Department = UDF_CHAR_3, and Nationality = UDF_CHAR_4	PR1	Location = Western and Employee Status = Active	A1	C1	TL1

Transaction Record Type	Primary Pricing Rule Type	Related Pricing Rule Type	Price Item in Related Pricing Rule Type	Price Item Parameters in Related Pricing Rule Type	Effective Pricing Rule	Best Fit Match for Price Item Parameters in Effective Pricing Rule	Account	Active Contract	Transaction Leg
			P2		PR2	Location = Western and Employee Status = Active	A2	C2	TL2
			P3		PR3	Location = Western and Employee Status = Active	A3	C3	TL3

**Note:** Here, the paid date is mapped to the **UDF\_DATE\_1** field in the CLAIM pricing rule type.

### Example 7: Transaction Leg Derivation

In the example 7, the system maps the claim transaction to the following price item, price item parameters, and account combinations:

- Price Item: P1; Price Item Parameter: Location = Western, Employee Status = Active, and Employee Department = HR; and Account: A1
- Price Item: P2; Price Item Parameter: Location = Western, Employee Status = Active, and Employee Department = HR; and Account: A2
- Price Item: P3; Price Item Parameter: Location = Western, Employee Status = Active, and Employee Department = HR; and Account: A3

**Note:** The nationality information of an employee is not received in the **UDF\_CHAR\_4** field, and therefore the claim transaction is not mapped to the **Nationality** price item parameter.

In the example 7, the system creates three transaction legs — TL1, TL2, and TL3 for the claim transaction. Once a transaction leg is created, the respective effective pricing rule is stamped against the transaction leg. In addition, the price item parameters of the transaction leg are grouped. In the example 7, the system creates one price item parameter group which contains the following price item parameters:

- Location = Western
- Employee Status = Active
- Employee Department = HR

A group is used to determine the price item pricing. A unique group ID is generated for each group. If a group with a set of price item parameters already exists in the system, a new group is not created. Instead, the existing group is used for determining the price item pricing.

**Note:** The price item parameter group contains only those price item parameters included in the related pricing rule type for which the parameter usage is set to **Pricing**.

If a pricing group is used while defining a pricing rule for a bill group, the system fetches the pricing rule for a claim transaction only when the following conditions are met:

- The paid date of the claim transaction falls within the pricing rule's date range.
- The employee attributes specified in the claim transaction match the criteria defined in any one of the pricing group rule.

- The employee attributes specified in the claim transaction match the price item parameters defined within the satisfied rule.

Let us understand this with the help of an example. A claim transaction is received with the following details:

- UDF\_CHAR\_1 is set to X
- UDF\_CHAR\_2 is set to Western
- UDF\_CHAR\_3 is set to Indian
- UDF\_CHAR\_4 is set to HR
- UDF\_CHAR\_5 is set to Permanent
- UDF\_CHAR\_6 is set to Senior Manager
- UDF\_CHAR\_7 s set to BG1
- UDF\_DATE\_1 03-01-2018
- Transaction Record Type is set to TR6

Let us assume that the following pricing structure is defined in the system:

Transaction Record Type	Primary Pricing Rule Type	Related Pricing Rule Type	Price Item in Related Pricing Rule Type	Price Item Parameters in Related Pricing Rule Type	Pricing Rule	Pricing Start Date	Pricing End Date	Pricing Group	Pricing Group Rule	Price Item Parameters	Fees
TR6	CLAIM	CLAIM BASED FEES	PP1	Designation = UDF_CHAR_6; Employee Group = UDF_CHAR_7	PR1	01-01-2018	31-12-2018	PG1	Rule 1 (where Source System = X, Parameter 1 = Western, Parameter 2 = Indian, Parameter 3 = HR, and Parameter 4 = Permanent)	Designation = Senior Manager and Employee Group = BG1	\$10
									Rule 1 (where Source System = X, Parameter 1 = Western, Parameter 2 = Indian, Parameter 3 = HR, and Parameter 4 = Permanent)	Designation = Senior Manager and Employee Group = BG2	\$12



Transaction Record Type	Primary Pricing Rule Type	Related Pricing Rule Type	Price Item in Related Pricing Rule Type	Price Item Parameters in Related Pricing Rule Type	Pricing Rule	Pricing Start Date	Pricing End Date	Pricing Group	Pricing Group Rule	Price Item Parameters	Fees
									Rule 2 (where Source System = X, Parameter 1 = Eastern, and Parameter 2 = Indian, Parameter 3 = HR, and Parameter 4 = Permanent)	Designation = Senior Manager and Employee Group = BG1	\$8
									Rule 2 (where Source System = X, Parameter 1 = Eastern, and Parameter 2 = Indian, Parameter 3 = HR, and Parameter 4 = Permanent)	Designation = Senior Manager and Employee Group = BG2	\$9

**Note:** Here, the source system is mapped to the **UDF\_CHAR\_1** field, the parameter 1 is mapped to the **UDF\_CHAR\_2** field, the parameter 2 is mapped to the **UDF\_CHAR\_3** field, the parameter 3 is mapped to the **UDF\_CHAR\_4** field, the parameter 4 is mapped to the **UDF\_CHAR\_5** field, and the paid date is mapped to the **UDF\_DATE\_1** field in the CLAIM pricing rule type.

#### Example 8: Effective Pricing Rule is Defined Using a Pricing Group

In the example 8, the system considers the PR1 pricing rule for PP1 because of the following reasons:

- The paid date (i.e. 03-01-2018) of the claim transaction falls within the PR1 pricing rule's date range (i.e. 01-01-2018 to 31-12-2018).
- The employee attributes specified in the claim transaction match the criteria defined in the Rule 1 (i.e. Source System = X, Parameter 1 = Western, Parameter 2 = Indian, Parameter 3 = HR, and Parameter 4 = Permanent).
- The employee attributes specified in the claim transaction match the price item parameters defined within the Rule 1.

The system then stores the pricing group rule which is satisfied against a parameter which is defined in the **Pricing Group Rule Parameter** option type of the **C1-ASOBLNG** feature configuration. In such case, the price item parameter group contains the price item parameters and the pricing group rule parameter. For example, Group A contains Designation = Senior Manager, Employee Group = BG1, and Pricing Group Rule Parameter = Rule 1.

In the example 8, the system could find the exact match for pricing parameters defined in the pricing group rule. However, if the exact match is not available, the system finds the effective pricing rule using the best fit match for the pricing parameters defined in the pricing group rule. Note that the system searches for the exact match in the effective

pricing rules at both the bill group and parent customer levels. If the exact match is not available at both the levels, the system finds the effective pricing rule using the best fit match for the pricing parameters (defined in the pricing group rule) first at the bill group level and then at the parent customer level.

Let us understand this with the help of an example. A claim transaction is received with the following details:

- UDF\_CHAR\_1 is set to X
- UDF\_CHAR\_2 is set to Western
- UDF\_CHAR\_3 is set to Indian
- UDF\_CHAR\_4 is set to HR
- UDF\_CHAR\_5 is set to Permanent
- UDF\_CHAR\_6 is set to Senior Manager
- UDF\_CHAR\_7 is set to BG1
- UDF\_DATE\_1 is set to 31-05-2018
- Transaction Record Type is set to TR6

Let us assume that the following pricing structure is defined in the system:

Transaction Record Type	Primary Pricing Rule Type	Related Pricing Rule Type	Price Item in Related Pricing Rule Type	Price Item Parameters in Related Pricing Rule Type	Pricing Rule	Pricing Start Date	Pricing End Date	Pricing Group	Pricing Group Rule	Price Item Parameters in Pricing Rule	Fees
TR6	CLAIM	CLAIM BASED FEES	PP1	Designation = UDF_CHAR_6, Employee Group = UDF_CHAR_7	PR1	01-01-2018	31-12-2018	PG1	Rule 1 (where Source System = X and Parameter 1 = Western)	Designation = Senior Manager; Employee Group = BG1	\$20
									Rule 1 (where Source System = X and Parameter 1 = Western)	Designation = Senior Manager; Employee Group = BG2	\$21
									Rule 2 (where Source System = X and Parameter 1 = Eastern)	Designation = Senior Manager; Employee Group = BG1	\$18

Transaction Record Type	Primary Pricing Rule Type	Related Pricing Rule Type	Price Item in Related Pricing Rule Type	Price Item Parameters in Related Pricing Rule Type	Pricing Rule	Pricing Start Date	Pricing End Date	Pricing Group	Pricing Group Rule	Price Item Parameters in Pricing Rule	Fees
									Rule 2 (where Source System = X and Parameter 1 = Eastern)	Designation = Senior Manager; Employee Group = BG2	\$19
			PP2		PR2	01-01-2018	31-12-2018	PG2	Rule 1 (where Source System = X, Parameter 1 = Eastern, Parameter 2 = Indian, Parameter 3 = HR, and Parameter 4 = Permanent)	Designation = Senior Manager; Employee Group = BG2	\$5
									Rule 1 (where Source System = X, Parameter 1 = Eastern, Parameter 2 = Indian, Parameter 3 = HR, and Parameter 4 = Permanent)	Designation = Senior Manager; Employee Group = BG1	\$5
									Rule 2 (where Source System = X, Parameter 1 = Western, Parameter 2 = Indian, Parameter 3 = HR, and Parameter 4 = Permanent)	Designation = Senior Manager; Employee Group = BG2	\$6

Transaction Record Type	Primary Pricing Rule Type	Related Pricing Rule Type	Price Item in Related Pricing Rule Type	Price Item Parameters in Related Pricing Rule Type	Pricing Rule	Pricing Start Date	Pricing End Date	Pricing Group	Pricing Group Rule	Price Item Parameters in Pricing Rule	Fees
									Rule 2 (where Source System = X, Parameter 1 = Western, Parameter 2 = Indian, Parameter 3 = HR, and Parameter 4 = Permanent)	Designation = Senior Manager; Employee Group = BG1	\$9

**Note:** Here, the source system is mapped to the **UDF\_CHAR\_1** field, the parameter 1 is mapped to the **UDF\_CHAR\_2** field, the parameter 2 is mapped to the **UDF\_CHAR\_3** field, the parameter 3 is mapped to the **UDF\_CHAR\_4** field, the parameter 4 is mapped to the **UDF\_CHAR\_5** field, and the paid date is mapped to the **UDF\_DATE\_1** field in the CLAIM pricing rule type.

#### Example 9: Effective Pricing Rule Derivation Using Best Fit Match for Pricing Parameters

In the example 9, the system could not find the exact match for the pricing parameters (i.e. Source System = X, Parameter 1 = Western, Parameter 2 = Indian, Parameter 3 = HR, and Parameter 4 = Permanent) in the effective pricing rule for PP1. Therefore, the system searches for the best fit match. While searching for the best fit match, the system rules out the optional parameter 4 (i.e. Parameter 4 = Permanent) and then checks whether the pricing group rule where Source System = X, Parameter 1 = Western, Parameter 2 = Indian, and Parameter 3 = HR exists in the effective pricing rule. If so, it considers the pricing group rule for further processing. If not, the system then rules out the optional parameter 3 (i.e. Parameter 3 = HR) and then checks whether the pricing group rule where Source System = X, Parameter 1 = Western, and Parameter 2 = Indian exists in the effective pricing rule. If so, it considers the pricing group rule for further processing. If not, the system then rules out the optional parameter 2 (i.e. Parameter 2 = Indian) and then checks whether the pricing group rule where Source System = X and Parameter 1 = Western exists in the effective pricing rule. If so, it considers the pricing group rule for further processing. If not, the status of the transaction is changed to **Error**.

In the example 9, the system considers Rule 1 where Source System = X and Parameter 1 = Western as the best fit match in the PR1 pricing rule for PP1. In addition, the employee attributes in the claim transaction satisfy the price item parameters (i.e. Designation = Senior Manager and Employee Group = BG1) defined within the Rule 1. Therefore, the system fetches PR1 as the effective pricing rule for PP1. In addition, the system fetches PR2 as the effective pricing rule for PP2. The system creates two price item parameter groups — One contains Designation = Senior Manager, Employee Group = BG1, and Pricing Group Rule Parameter = Rule 1 and another contains Designation = Senior Manager, Employee Group = BG1, and Pricing Group Rule Parameter = Rule 2. Once the price item parameter group is created, the system creates the aggregation parameter group. An aggregation parameter group contains all price item parameters included in the related pricing rule type for which the parameter usage is set to **Aggregation**.

If the effective pricing rule is not derived for a price item and price item parameters combination or if the account or active contract for the account is not derived, the system does not create a transaction leg for the respective price item. Let us understand this with the help of an example:

Related Pricing Rule Type	Price Item	Price Item Parameters	Effective Pricing Rule	Account	Active Contract	Transaction Leg
RETENTION TYPE CLAIM BASED	PP11	Designation = UDF_CHAR_6, Employee Status = UDF_CHAR_7	-	-	-	-
	PP12		PR12	A1	C1	TL11
	PP13		PR13	-	-	-
	PP14		PR14	A2	-	-
	PP15		PR15	-	-	-
	PP16		-	-	-	-
	PP17		PR17	A2	C2	TL12

### Example 10: No. of Transaction Legs Derived

In the example 10, the system could not find the effective pricing rule for PP11 and PP16, the required account for PP13 and PP15, and the active contract for PP14 on A2. Therefore, in this case, the system creates two transaction legs — TL11 and TL12 for the transaction.

If the eligibility rule type is defined for a price item, the system maps the transaction to the price item only when the eligibility rule is satisfied. If the eligibility rule is not satisfied, the system does not consider the price item for billing. For example,

Sequence	Related Pricing Rule Type	Rule Type Eligibility Criteria Met	Price Item	Price Item Eligibility Criteria Met	Effective Pricing Rule	Account	Active Contract	Transaction Leg
10	RETENTION TYPE CLAIM BASED	Yes	PE1	Yes	PR1	A1	C1	TL1
			PE2	-	PR2	A2	-	-
			PE3	No	-	-	-	-
20	CLAIM BASED FEES	-	PE4	-	PR3	A1	C2	TL2
			PE5	Yes	PR4	-	-	-
			PE6	No	-	-	-	-
30	CLAIM FEE CHARGES	No	PE7	-	-	-	-	-
			PE8	-	-	-	-	-
			PE9	-	-	-	-	-

### Example 11: Price Item Eligibility for Transaction Leg Derivation

In the example 11, the eligibility criteria is defined for the RETENTION TYPE CLAIM BASED and CLAIM FEE CHARGES pricing rule types. However, the eligibility criteria for the CLAIM FEE CHARGES pricing rule type was not satisfied, and therefore it is not used for deriving the transaction legs. The eligibility criteria for PE1 and PE5 was satisfied, but the eligibility criteria for PE3 and PE6 was not satisfied. Further, the system could not find the required account for PE5 and the active contract for PE2 on A2. Therefore, in this case, the system creates two transaction legs (i.e. TL1 and TL2) for the claim transaction. For more information about the related pricing rule type eligibility and price item eligibility features, refer to the [Related Pricing Rule Type Eligibility](#) on page 2724 and [Price Item Eligibility](#) on page 2726 sections, respectively.

Once a transaction leg is created, the derivation date is set as the processing date corresponding to the transaction leg.

## Account and Price Item Derivation (for the Retention Type Enrollment Based Pricing Rule Type Category)

The **Validate Transaction and Derive Price Item (C1-TXNIP)** batch maps the retroactive and non-retroactive enrollment transactions to one or more price item and price item parameters which are defined in the respective primary pricing rule type. This is possible only when an algorithm created using the **C1\_ACCPRIDRV** algorithm type is attached to the **Account and Price Item Derivation** system event of the primary pricing rule type.

This algorithm fetches the effective pricing rule for each price item and price item parameters combination specified in the primary pricing rule type on the derivation date. The system considers the coverage end date and coverage start date as the derivation date while fetching the effective pricing rules for the retroactive and non-retroactive enrollment transactions, respectively. This algorithm first searches for the effective pricing rule for a price item and price item parameters combination which is defined for the policy at the bill group level. If the system does not find any effective pricing rule for a price item and price item parameters combination which is defined for the policy at the bill group level, it inherits the effective pricing rule for a price item and price item parameters combination from the parent customer level.

For example, if the system receives a non-retroactive enrollment transaction with the following details:

- UDF\_DATE\_1 is set to 01-02-2018
- UDF\_DATE\_2 is set to 28-02-2018
- Transaction Record Type is set to TR3

Let us assume that the following pricing structure is defined in the system:

Transaction Record Type	Primary Pricing Rule Type	Price Item	Pricing Rule	Pricing Start Date	Pricing End Date	Assignment Level
TR3	RETENTION TYPE ENROLLMENT BASED	P1	C1P1	01-01-2018	31-12-2018	Parent Customer
			C2P1	01-01-2018	31-12-2018	Bill Group
			C3P1	01-01-2019	30-06-2019	Bill Group
		P2	C1P2	01-06-2017	31-12-2017	Bill Group
			C2P2	01-01-2018	31-12-2018	Parent Customer
			C3P2	01-01-2019	30-06-2019	Bill Group

**Note:** Here, the coverage start date is mapped to the **UDF\_DATE\_1** field and the coverage end date is mapped to the **UDF\_DATE\_2** field in the RETENTION TYPE ENROLLMENT BASED pricing rule type.

### Example 1: Effective Pricing Rule Derivation

In the example 1, the system fetches C2P1 and C2P2 pricing rules for P1 and P2, respectively, which are effective on the coverage start date. Note that the effective pricing rule for P1 is derived at the bill group level, whereas the effective pricing rule for P2 is derived from the parent customer level.

While fetching the effective pricing rule, the system first searches for exact match for the price item parameters at both the levels. For example, if the system receives a retroactive enrollment transaction with the following details:

- UDF\_CHAR\_1 is set to Western
- UDF\_CHAR\_2 is set to Active

- UDF\_DATE\_1 is set to 01-03-2018
- UDF\_DATE\_2 is set to 31-03-2018
- Transaction Record Type is set to TR4

Let us assume that the following pricing structure is defined in the system:

Transaction Record Type	Primary Pricing Rule Type	Price Item	Price Item Parameters	Pricing Rule	Pricing Start Date	Pricing End Date	Price Item Parameters in Pricing Rule	Fees	Assignment Level	
TR4	ENROLLMENT BASED FEES	P1	Location = UDF_CHAR_1 and Employee Status = UDF_CHAR_2	C1P1	01-01-2018	31-12-2018	Location = Western and Employee Status = Active	\$10	Parent Customer	
							Location = Eastern and Employee Status = Active	\$12		
							Location = Eastern and Employee Status = Retired	\$11		
							Location = Western and Employee Status = Retired	\$9		
				C2P1	01-01-2018	31-12-2018	Location = Western and Employee Status = Active	\$8		Bill Group
							Location = Eastern and Employee Status = Active	\$9		
							Location = Eastern and Employee Status = Retired	\$10		
							Location = Western and Employee Status = Retired	\$9		

**Note:** Here, the coverage start date is mapped to the **UDF\_DATE\_1** field and the coverage end date is mapped to the **UDF\_DATE\_2** field in the ENROLLMENT BASED FEES pricing rule type.

### Example 2: Exact Match for Price Item Parameters

In the example 2, the system fetches the C2P1 pricing rule for P1 because of the following reasons:

- The coverage end date (i.e. 31-03-2018) of the retroactive enrollment transaction falls within the date range (i.e. 01-01-2018 to 31-12-2018) of the C2P1 pricing rule which is defined at the bill group level.
- It contains the exact match for the price item parameters which are received in the transaction.

If the system cannot find the exact match for the price item parameters at both the levels, the system searches for the best fit match for the price item parameters first at the bill group level and then at the parent customer level. For example, if the system receives a retroactive enrollment transaction with the following details:

- UDF\_CHAR\_1 is set to Western
- UDF\_CHAR\_2 is set to Active
- UDF\_CHAR\_3 is set to HR
- UDF\_CHAR\_4 is set to Indian
- UDF\_DATE\_1 is set to 01-03-2018
- UDF\_DATE\_2 is set to 31-03-2018
- Transaction Record Type is set to TR5

Let us assume that the following pricing structure is defined in the system:

Transaction Record Type	Primary Pricing Rule Type	Price Item	Price Item Parameters	Pricing Rule	Pricing Start Date	Pricing End Date	Price Item Parameters in Pricing Rule	Fees	Assignment Level
TR5	ENROLLMENT BASED CHARGES	P3	Location = UDF_CHAR_1, Employee Status = UDF_CHAR_2, Employee Department = UDF_CHAR_3, and Nationality = UDF_CHAR_4	C1P3	01-01-2018	31-12-2018	Location = Western and Employee Status = Active	\$10	Bill Group
							Location = Eastern and Employee Status = Active	\$12	
							Location = Eastern and Employee Status = Retired	\$11	
							Location = Western and Employee Status = Retired	\$9	

**Note:**

Here, the coverage start date is mapped to the **UDF\_DATE\_1** field and the coverage end date is mapped to the **UDF\_DATE\_2** field in the ENROLLMENT BASED CHARGES pricing rule type.

Here, the **Location** and **Employee Status** parameters are mandatory for P3. However, the **Employee Department** and **Nationality** parameters are optional with the priority set to 1 and 2, respectively.

**Example 3: Best Fit Match for Price Item Parameters**

In the example 3, the system could not find the exact match for the price item parameters (i.e. Location = Western, Employee Status = Active, Employee Department = HR, and Nationality = Indian) in the effective pricing rule for P3. Therefore, the system searches for the best fit match. While searching for the best fit match, the system rules out the optional parameter with lowest priority (i.e. Nationality = Indian) and checks whether pricing is defined for the price item parameters (i.e. Location = Western, Employee Status = Active, and Employee Department = HR) in the effective pricing rule. If so, it considers C1P3 as the effective pricing rule for P3. If not, the system rules out the optional parameter with the next lowest priority (i.e. Employee Department = HR) and checks whether pricing is defined for the price item



parameters (i.e. Location = Western and Employee Status = Active) in the effective pricing rule. If so, it considers C1P3 as the effective pricing rule for P3. If not, the status of the transaction is changed to **Error**.

In the example 3, the system considers pricing defined for the price item parameters (i.e. Location = Western and Employee Status = Active) as the best fit match, and therefore fetches C1P3 as the effective pricing rule for P3. While fetching the effective pricing rule, the system considers only those price item parameters specified in the primary pricing rule type for which the parameter usage is set to **Pricing**. For retroactive enrollment transactions, the system considers only those effective pricing rules where the **Exempt Retro Transactions** option is not selected.

The system then derives the account with a particular invoice type (to which a price item must be billed) based on the priority which is defined for the respective price item in the pricing rule type. For example,

Price Item	Priority	Invoice Type	Account
P1	10	Standard	A1
	20	Retention	A2
P2	10	Retention	A2
	20	Standard	A1

#### Example 4: Priority Based Account Derivation

In the example 4, while mapping the enrollment transaction to P1, the system checks whether an account where the **Invoice Type (C1INVTYP)** characteristic is set to **Standard** exists for the bill group. If so, it considers the standard account (A1) of the bill group for billing. However, if an account where the **Invoice Type (C1INVTYP)** characteristic is set to **Standard** does not exist for the bill group, the system checks whether an account where the **Invoice Type (C1INVTYP)** characteristic is set to **Retention** exists for the bill group. If so, it considers the retention account (A2) of the bill group for billing. If an account where the **Invoice Type (C1INVTYP)** characteristic is set to **Retention** does not exist for the bill group, the status of the transaction is changed to **Error**.

Similarly, while mapping the enrollment transaction to P2, the system considers the account of the bill group which is available based on the priority. The system derives the billing account for only those price items for which the effective pricing rule is derived.

**Note:** The characteristic type which indicates the type of account (for example, **C1INVTYP**) must be specified in the **Invoice Type Characteristic Type** option type of the **C1-ASOBLLNG** feature configuration. Otherwise, erroneous results might occur.

Once the account is derived, the system then checks whether the account has one active contract of the contract type which is associated with the price item. If so, it fetches the contract for further processing. Once the effective pricing rule, account, and active contract are derived, the transaction is mapped to the respective price item, price item parameters, and account. A transaction leg is created for each price item, price item parameters, and account combination. For example, if the system receives a non-retroactive enrollment transaction with the following details:

- UDF\_CHAR\_1 is set to Western
- UDF\_CHAR\_2 is set to Active
- UDF\_CHAR\_3 is set to HR
- UDF\_DATE\_1 is set to 01-03-2018
- UDF\_DATE\_2 is set to 31-03-2018
- Transaction Record Type is set to TR5

Let us assume that the non-retroactive enrollment transaction is mapped to the following price item, price item parameters, and account combinations:

Transaction Record Type	Primary Pricing Rule Type	Price Item	Price Item Parameters	Effective Pricing Rule	Best Fit Match for Price Item Parameters in Effective Pricing Rule	Account	Active Contract	Transaction Leg
TR5	ENROLLMENT BASED FEES	P1	Location = UDF_CHAR_1, Employee Status = UDF_CHAR_2, Employee Department = UDF_CHAR_3, and Nationality = UDF_CHAR_4	PR1	Location = Western and Employee Status = Active	A1	C1	TL1
		P2		PR2	Location = Western and Employee Status = Active	A2	C2	TL2
		P3		PR3	Location = Western and Employee Status = Active	A3	C3	TL3

**Note:** Here, the coverage start date is mapped to the **UDF\_DATE\_1** field and the coverage end date is mapped to the **UDF\_DATE\_2** field in the ENROLLMENT BASED FEES pricing rule type.

#### Example 5: Transaction Leg Derivation

In the example 5, the system maps the non-retroactive enrollment transaction to the following price item, price item parameters, and account combinations:

- Price Item: P1; Price Item Parameter: Location = Western, Employee Status = Active, and Employee Department = HR; and Account: A1
- Price Item: P2; Price Item Parameter: Location = Western, Employee Status = Active, and Employee Department = HR; and Account: A2
- Price Item: P3; Price Item Parameter: Location = Western, Employee Status = Active, and Employee Department = HR; and Account: A3

**Note:** The nationality information of an employee is not received in the **UDF\_CHAR\_4** field, and therefore the non-retroactive enrollment transaction is not mapped to the **Nationality** price item parameter.

In the example 5, the system creates three transaction legs — TL1, TL2, and TL3 for the non-retroactive enrollment transaction. Once a transaction leg is created, the respective effective pricing rule is stamped against the transaction leg. In addition, the price item parameters of the transaction leg are grouped. In the example 5, the system creates one price item parameter group which contains the following price item parameters:

- Location = Western
- Employee Status = Active
- Employee Department = HR

A group is used to determine the price item pricing. A unique group ID is generated for each group. If a group with a set of price item parameters already exists in the system, a new group is not created. Instead, the existing group is used for determining the price item pricing.

**Note:** The price item parameter group contains only those price item parameters included in the pricing rule type for which the parameter usage is set to **Pricing**.

The following table describes how the system fetches a pricing rule when a pricing group is used while defining the pricing rule for a bill group:

If the transaction is a...	Then the system fetches the pricing rule only when the following conditions are met...
Retroactive enrollment transaction	<ul style="list-style-type: none"> <li>• The coverage end date of the retroactive enrollment transaction falls within the pricing rule's date range.</li> <li>• The exact or best fit match is available for the price item parameters in the effective pricing rule.</li> <li>• The retroactive enrollment transaction satisfies the criteria defined in any one of the pricing group rule.</li> </ul>
Non-retroactive enrollment transaction	<ul style="list-style-type: none"> <li>• The coverage start date of the non-retroactive enrollment transaction falls within the pricing rule's date range.</li> <li>• The exact or best fit match is available for the price item parameters in the effective pricing rule.</li> <li>• The non-retroactive enrollment transaction satisfies the criteria defined in any one of the pricing group rule.</li> </ul>

Let us understand this with the help of an example. A retroactive enrollment transaction is received with the following details:

- UDF\_CHAR\_1 is set to X
- UDF\_CHAR\_2 is set to Western
- UDF\_CHAR\_3 is set to Indian
- UDF\_CHAR\_4 is set to HR
- UDF\_CHAR\_5 is set to Permanent
- UDF\_CHAR\_6 is set to Senior Manager
- UDF\_CHAR\_7 is set to BG1
- UDF\_DATE\_1 is set to 01-03-2018
- UDF\_DATE\_2 is set to 31-03-2018
- Transaction Record Type is set to TR6

Let us assume that the following pricing structure is defined in the system:

Transaction Record Type	Primary Pricing Rule Type	Price Item	Price Item Parameters	Pricing Rule	Pricing Start Date	Pricing End Date	Pricing Group	Pricing Group Rule	Price Item Parameters	Fees
TR6	ENROLLMENT BASED FEES	PP1	Designation = UDF_CHAR_6; Employee Group = UDF_CHAR_7	PR1	01-01-2018	31-12-2018	PG1	Rule 1 (where Source System = X, Parameter 1 = Western, Parameter 2 = Indian, Parameter 3 = HR, and Parameter 4 = Permanent)	Designation = Senior Manager and Employee Group = BG1	\$10
								Rule 1 (where Source System = X, Parameter 1 = Western, Parameter 2 = Indian, Parameter 3 = HR, and Parameter 4 = Permanent)	Designation = Senior Manager and Employee Group = BG2	\$12
								Rule 2 (where Source System = X, Parameter 1 = Eastern, and Parameter 2 = Indian, Parameter 3 = HR, and Parameter 4 = Permanent)	Designation = Senior Manager and Employee Group = BG1	\$8
								Rule 2 (where Source System = X, Parameter 1 = Eastern, and Parameter 2 = Indian, Parameter 3 = HR, and Parameter 4 = Permanent)	Designation = Senior Manager and Employee Group = BG2	\$9

**Note:** Here, the source system is mapped to the **UDF\_CHAR\_1** field, the parameter 1 is mapped to the **UDF\_CHAR\_2** field, the parameter 2 is mapped to the **UDF\_CHAR\_3** field, the parameter 3 is mapped to the **UDF\_CHAR\_4** field, the parameter 4 is mapped to the **UDF\_CHAR\_5** field, the coverage start date is mapped to the **UDF\_DATE\_1** field, and the coverage end date is mapped to the **UDF\_DATE\_2** field in the ENROLLMENT BASED FEES pricing rule type.

### Example 6: Effective Pricing Rule is Defined Using a Pricing Group

In the example 6, the system considers the PR1 pricing rule for PP1 because of the following reasons:

- The coverage end date (i.e. 31-03-2018) of the retroactive enrollment transaction falls within the PR1 pricing rule's date range (i.e. 01-01-2018 to 31-12-2018).
- The employee attributes specified in the retroactive enrollment transaction match the criteria defined in the Rule 1 (i.e. Source System = X, Parameter 1 = Western, Parameter 2 = Indian, Parameter 3 = HR, and Parameter 4 = Permanent)
- The employee attributes specified in the retroactive enrollment transaction match the price item parameters defined within the Rule 1.

The system then stores the pricing group rule which is satisfied against a parameter which is defined in the **Pricing Group Rule Parameter** option type of the **C1-ASOBLLNG** feature configuration. In such case, the price item parameter group contains the price item parameters and the pricing group rule parameter. For example, Group A contains Designation = Senior Manager, Employee Group = BG1, and Pricing Group Rule Parameter = Rule 1.

In the example 6, the system could find the exact match for pricing parameters defined in the pricing group rule. However, if the exact match is not available, the system finds the effective pricing rule using the best fit match for the pricing parameters defined in the pricing group rule. Note that the system searches for the exact match in the effective pricing rules at both the bill group and parent customer levels. If the exact match is not available at both the levels, the system finds the effective pricing rule using the best fit match for the pricing parameters (defined in the pricing group rule) first at the bill group level and then at the parent customer level.

Let us understand this with the help of an example. A non-retroactive enrollment transaction is received with the following details:

- UDF\_CHAR\_1 is set to X
- UDF\_CHAR\_2 is set to Western
- UDF\_CHAR\_3 is set to Indian
- UDF\_CHAR\_4 is set to HR
- UDF\_CHAR\_5 is set to Permanent
- UDF\_CHAR\_6 is set to Senior Manager
- UDF\_CHAR\_7 is set to BG1
- UDF\_DATE\_1 is set to 01-05-2018
- UDF\_DATE\_2 is set to 31-05-2018
- Transaction Record Type is set to TR6

Let us assume that the following pricing structure is defined in the system:

Transaction Record Type	Primary Pricing Rule Type	Price Item	Price Item Parameters	Pricing Rule	Pricing Start Date	Pricing End Date	Pricing Group	Pricing Group Rule	Price Item Parameters in Pricing Rule	Fees
TR6	ENROLLMENT BASED FEES	PP1	Designation = UDF_CHAR_6, Employee Group = UDF_CHAR_7	PR1	01-01-2018	31-12-2018	PG1	Rule 1 (where Source System = X and Parameter 1 = Western)	Designation = Senior Manager; Employee Group = BG1	\$20
								Rule 1 (where Source System = X and Parameter 1 = Western)	Designation = Senior Manager; Employee Group = BG2	\$21
								Rule 2 (where Source System = X and Parameter 1 = Eastern)	Designation = Senior Manager; Employee Group = BG1	\$18
								Rule 2 (where Source System = X and Parameter 1 = Eastern)	Designation = Senior Manager; Employee Group = BG2	\$19
		PP2	PR2	01-01-2018	31-12-2018	PG2	Rule 1 (where Source System = X, Parameter 1 = Eastern, Parameter 2 = Indian, Parameter 3 = HR, and Parameter 4 = Permanent)	Designation = Senior Manager; Employee Group = BG2	\$5	
							Rule 1 (where Source System = X, Parameter 1 = Eastern, Parameter 2 = Indian, Parameter 3 = HR, and Parameter 4 = Permanent)	Designation = Senior Manager; Employee Group = BG1	\$5	

Transaction Record Type	Primary Pricing Rule Type	Price Item	Price Item Parameters	Pricing Rule	Pricing Start Date	Pricing End Date	Pricing Group	Pricing Group Rule	Price Item Parameters in Pricing Rule	Fees
								Rule 2 (where Source System = X, Parameter 1 = Western, Parameter 2 = Indian, Parameter 3 = HR, and Parameter 4 = Permanent)	Designation = Senior Manager; Employee Group = BG2	\$6
								Rule 2 (where Source System = X, Parameter 1 = Western, Parameter 2 = Indian, Parameter 3 = HR, and Parameter 4 = Permanent)	Designation = Senior Manager; Employee Group = BG1	\$9

**Note:** Here, the source system is mapped to the **UDF\_CHAR\_1** field, the parameter 1 is mapped to the **UDF\_CHAR\_2** field, the parameter 2 is mapped to the **UDF\_CHAR\_3** field, the parameter 3 is mapped to the **UDF\_CHAR\_4** field, the parameter 4 is mapped to the **UDF\_CHAR\_5** field, the coverage start date is mapped to the **UDF\_DATE\_1** field, and the coverage end date is mapped to the **UDF\_DATE\_2** field in the ENROLLMENT BASED FEES pricing rule type.

#### Example 7: Effective Pricing Rule Derivation Using Best Fit Match for Pricing Parameters

In the example 7, the system could not find exact match for the pricing parameters (i.e. Source System = X, Parameter 1 = Western, Parameter 2 = Indian, Parameter 3 = HR, and Parameter 4 = Permanent) in the effective pricing rule for PP1. Therefore, the system searches for the best fit match. While searching for the best fit match, the system rules out the optional parameter 4 (i.e. Parameter 4 = Permanent) and then checks whether the pricing group rule where Source System = X, Parameter 1 = Western, Parameter 2 = Indian, and Parameter 3 = HR exists in the effective pricing rule. If so, it considers the pricing group rule for further processing. If not, the system then rules out the optional parameter 3 (i.e. Parameter 3 = HR) and then checks whether the pricing group rule where Source System = X, Parameter 1 = Western, and Parameter 2 = Indian exists in the effective pricing rule. If so, it considers the pricing group rule for further processing. If not, the system then rules out the optional parameter 2 (i.e. Parameter 2 = Indian) and then checks whether the pricing group rule where Source System = X and Parameter 1 = Western exists in the effective pricing rule. If so, it considers the pricing group rule for further processing. If not, the status of the transaction is changed to **Error**.

In the example 7, the system considers Rule 1 where Source System = X and Parameter 1 = Western as the best fit match in the PR1 pricing rule for PP1. In addition, the employee attributes in the non-retroactive enrollment transaction satisfy the price item parameters (i.e. Designation = Senior Manager and Employee Group = BG1) defined within Rule 1. Therefore, the system fetches PR1 as the effective pricing rule for PP1. In addition, the system fetches PR2 as the effective pricing rule for PP2. The system creates two price item parameter groups — One contains Designation = Senior Manager, Employee Group = BG1, and Pricing Group Rule Parameter = Rule 1 and another contains Designation = Senior Manager, Employee Group = BG1, and Pricing Group Rule Parameter = Rule 2. Once the price item parameter

group is created, the system creates the aggregation parameter group. An aggregation parameter group contains all price item parameters included in the pricing rule type for which the parameter usage is set to **Aggregation**.

If the effective pricing rule is not derived for a price item and price item parameters combination or if the account or active contract for the account is not derived, the system does not create a transaction leg for the respective price item. Let us understand this with the help of an example:

Primary Pricing Rule Type	Price Item	Price Item Parameters	Effective Pricing Rule	Account	Active Contract	Transaction Leg
ENROLLMENT BASED FEES	PP1	Designation = UDF_CHAR_6, Employee Status = UDF_CHAR_7	-	-	-	-
	PP2		PR2	-	-	-
	PP3		PR3	A3	C3	TL1
	PP4		-	-	-	-
	PP5		PR5	A2	C1	TL2
	PP6		PR6	A1	-	-

#### Example 8: No. of Transaction Legs Derived

In the example 8, the system could not find the effective pricing rule for PP1 and PP4, the required account for PP2, and the active contract for PP6 on A1. Therefore, in this case, the system creates two transaction legs — TL1 and TL2 for the enrollment transaction.

If the eligibility rule type is defined of a price item, the system maps the enrollment transaction to the price item only when the eligibility rule is satisfied. If the eligibility rule is not satisfied, the system does not consider the price item for billing. For example,

Price Item	Eligibility Criteria Met	Effective Pricing Rule	Account	Active Contract	Transaction Leg
PE1	Yes	PR1	A1	C1	TL1
PE2	-	PR2	-	-	-
PE3	No	-	-	-	-
PE4	Yes	-	-	-	-
PE5	Yes	PR3	A2	-	-
PE6	Yes	PR4	-	-	-

#### Example 9: Price Item Eligibility for Transaction Leg Derivation

In the example 9, the eligibility criteria was defined for PE1, PE3, PE4, PE5, and PE6. The eligibility criteria was satisfied for PE1, PE4, PE5, and PE6, but not for PE3. Further, the system could not find the effective pricing rule for PE4, the required account for PE2 and PE6, and the active contract for PE5 on A2. Therefore, in this case, the system creates one transaction leg (i.e. TL1) for the enrollment transaction. For more information, refer to the [Price Item Eligibility](#) on page 2726 section.

Once a transaction leg is created, the derivation date is set as the processing date corresponding to the transaction leg.

## Account and Price Item Derivation (for the Ancillary Pricing Rule Type Category)

The **Validate Transaction and Derive Price Item (C1-TXNIP)** batch maps an ancillary transaction to one or more price item and price item parameters which are defined in the respective primary pricing rule type. This is possible only



when an algorithm created using the **C1\_ACCPRIDRV** algorithm type is attached to the **Account and Price Item Derivation** system event of the primary pricing rule type.

This algorithm fetches the effective pricing rule for each price item and price item parameters combination specified in the primary pricing rule type on the derivation date. The system considers the paid date as the derivation date. This algorithm first searches for the effective pricing rule for a price item and price item parameters combination which is defined for the policy at the bill group level. If the system does not find any effective pricing rule for a price item and price item parameters combination which is defined for the policy at the bill group level, it inherits the effective pricing rule for a price item and price item parameters combination from the parent customer level.

For example, if the system receives an ancillary transaction with the following details:

- UDF\_CHAR\_6 is set to BC1
- UDF\_CHAR\_7 is set to PASS
- UDF\_DATE\_1 is set to 15-03-2018
- Transaction Record Type is set to TR1

Let us assume that the following pricing structure is defined in the system:

Transaction Record Type	Primary Pricing Rule Type	Price Item	Price Item Parameters	Pricing Rule	Pricing Start Date	Pricing End Date	Pricing Arrangement	Assignment Level
TR1	ANCILLARY	P1	BCHGLINETYPE = UDF_CHAR_6 and PRICINGARRANGEMENT = UDF_CHAR_7	C1P1	01-01-2018	31-12-2018	Pass Through without Markup or Markdown	Parent Customer
				C2P1	01-01-2018	31-12-2018	Pass Through without Markup or Markdown	Bill Group
				C3P1	01-01-2018	31-12-2018	Pass Through without Markup or Markdown	Bill Group
		P2		C1P2	01-06-2017	31-12-2017	Pass Through without Markup or Markdown	Bill Group
				C2P2	01-01-2018	31-12-2018	Pass Through without Markup or Markdown	Parent Customer
				C3P2	01-01-2019	30-06-2019	Pass Through without Markup or Markdown	Bill Group

**Note:**

Here, the **Pass Through without Markup or Markdown** pricing arrangement identifier is set to **PASS** in the ANCILLARY pricing rule type. This means that the system will consider only effective pricing rules where the pricing arrangement is set to **Pass Through without Markup or Markdown** when the ancillary transaction is received where **UDF\_CHAR\_7** is set to **PASS**.

Here, the paid date is mapped to the **UDF\_DATE\_1** field in the ANCILLARY pricing rule type.

**Example 1: Effective Pricing Rule Derivation**

In the example 1, the system fetches C2P1 and C2P2 pricing rules for P1 and P2, respectively, because of the following reasons:

- The paid date (i.e. 15-03-2018) of the ancillary transaction falls within the C2P1 and C2P2 pricing rules' date range (i.e. 01-01-2018 to 31-12-2018).
- The pricing arrangement is set to **Pass Through without Markup or Markdown** in the C2P1 and C2P2 pricing rules.

Note that the effective pricing rule for P1 is derived at the bill group level, whereas the effective pricing rule for P2 is derived from the parent customer level.

**Note:** The price item parameters (i.e. BCHGLINETYPE and PRICINGARRANGEMENT) must be defined in the **Billable Charge Line Type Parameter** and **Pricing Arrangement Parameter** option types of the **C1-ASOBLLNG** feature configuration, respectively. Otherwise, erroneous results might occur.

The system then derives the account with a particular invoice type (to which a price item must be billed) based on the priority which is defined for the respective price item in the pricing rule type. For example,

Price Item	Priority	Invoice Type	Account
P1	10	Standard	A1
	20	Retention	A2
P2	10	Retention	A2
	20	Standard	A1

**Example 2: Priority Based Account Derivation**

In the example 2, while mapping the claim transaction to P1, the system checks whether an account where the **Invoice Type (C1INVTYP)** characteristic is set to **Standard** exists for the bill group. If so, it considers the standard account (A1) of the bill group for billing. However, if an account where the **Invoice Type (C1INVTYP)** characteristic is set to **Standard** does not exist for the bill group, the system checks whether an account where the **Invoice Type (C1INVTYP)** characteristic is set to **Retention** exists for the bill group. If so, it considers the retention account (A2) of the bill group for billing. If an account where the **Invoice Type (C1INVTYP)** characteristic is set to **Retention** does not exist for the bill group, the status of the transaction is changed to **Error**.

Similarly, while mapping the claim transaction to P2, the system considers the account of the bill group which is available based on the priority. The system derives the billing account for only those price items for which the effective pricing rule is derived.

**Note:** The characteristic type which indicates the type of account (for example, **C1INVTYP**) must be specified in the **Invoice Type Characteristic Type** option type of the **C1-ASOBLLNG** feature configuration. Otherwise, erroneous results might occur.

Once the account is derived, the system then checks whether the account has one active contract of the contract type which is associated with the price item. If so, it fetches the contract for further processing. Once the effective pricing rule, account, and active contract are derived, the transaction is mapped to the respective price item, price item parameters,

and account. A transaction leg is created for each price item, price item parameters, and account combination. For example, if the system receives an ancillary transaction with the following details:

- UDF\_CHAR\_6 is set to BC1
- UDF\_CHAR\_7 is set to PASS
- UDF\_DATE\_1 is set to 15-03-2018
- Transaction Record Type is set to TR1

Let us assume that the ancillary transaction is mapped to the following price item, price item parameters, and account combinations:

Transaction Record Type	Primary Pricing Rule Type	Price Item	Price Item Parameters	Effective Pricing Rule	Pricing Arrangement	Account	Active Contract	Transaction Leg
TR1	ANCILLARY	P1	BCHGLINETYPE = UDF_CHAR_6 and PRICINGARRANGEMENT = UDF_CHAR_7	PR1	Pass Through without Markup or Markdown	A1	C1	TL1
		P2		PR2	Pass Through without Markup or Markdown	A2	C2	TL2
		P3		PR3	Pass Through without Markup or Markdown	A3	C3	TL3

**Note:** Here, the paid date is mapped to the **UDF\_DATE\_1** field and the **Pass Through without Markup or Markdown** pricing arrangement identifier is set to **PASS** in the ANCILLARY pricing rule type.

### Example 3: Transaction Leg Derivation

In the example 3, the system maps the ancillary transaction to the following price item, price item parameters, and account combinations:

- Price Item: P1; Price Item Parameter: BCHGLINETYPE = BC1 and PRICINGARRANGEMENT = Pass Through without Markup or Markdown; and Account: A1
- Price Item: P2; Price Item Parameter: BCHGLINETYPE = BC1 and PRICINGARRANGEMENT = Pass Through without Markup or Markdown; and Account: A2
- Price Item: P3; Price Item Parameter: BCHGLINETYPE = BC1 and PRICINGARRANGEMENT = Pass Through without Markup or Markdown; and Account: A3

In the example 3, the system creates three transaction legs — TL1, TL2, and TL3 for the ancillary transaction. Once a transaction leg is created, the respective effective pricing rule is stamped against the transaction leg. In addition, the price item parameters of the transaction leg are grouped. In the example 3, the system creates one price item parameter group which contains the following price item parameters:

- BCHGLINETYPE = BC1
- PRICINGARRANGEMENT = PASS

A group is used to determine the price item pricing. A unique group ID is generated for each group. If a group with a set of price item parameters already exists in the system, a new group is not created. Instead, the existing group is used for determining the price item pricing.

**Note:** The price item parameter group contains only those price item parameters included in the primary pricing rule type for which the parameter usage is set to **Pricing**.

If a pricing group is used while defining a pricing rule for a bill group, the system fetches the pricing rule for an ancillary transaction only when the following conditions are met:

- The paid date of the ancillary transaction falls within the pricing rule's date range.
- The employee attributes specified in the ancillary transaction match the criteria defined in any one of the pricing group rule.
- The pricing arrangement specified in the ancillary transaction matches the pricing arrangement specified in the pricing rule.

Let us understand this with the help of an example. An ancillary transaction is received with the following details:

- UDF\_CHAR\_1 is set to X
- UDF\_CHAR\_2 is set to Western
- UDF\_CHAR\_3 is set to Indian
- UDF\_CHAR\_4 is set to HR
- UDF\_CHAR\_5 is set to Permanent
- UDF\_CHAR\_6 is set to BC1
- UDF\_CHAR\_7 is set to PASS
- UDF\_DATE\_1 is set to 26-01-2018
- Transaction Record Type is set to TR6

Let us assume that the following pricing structure is defined in the system:

Transaction Record Type	Primary Pricing Rule Type	Price Item	Price Item Parameters	Pricing Rule	Pricing Start Date	Pricing End Date	Pricing Group	Pricing Group Rule	Pricing Arrangement
TR6	ANCILLARY	P1	BCHGLINETYPE = UDF_CHAR_6 and PRICINGARRANGEMENT = UDF_CHAR_7	PR1	01-01-2018	31-12-2018	PG1	Rule 1 (where Source System = X, Parameter 1 = Western, Parameter 2 = Indian, Parameter 3 = HR, and Parameter 4 = Permanent)	Pass Through without Markup or Markdown

Transaction Record Type	Primary Pricing Rule Type	Price Item	Price Item Parameters	Pricing Rule	Pricing Start Date	Pricing End Date	Pricing Group	Pricing Group Rule	Pricing Arrangement
								Rule 2 (where Source System = X, Parameter 1 = Eastern, and Parameter 2 = Indian, Parameter 3 = HR, and Parameter 4 = Permanent)	Pass Through without Markup or Markdown

**Note:** Here, the source system is mapped to the **UDF\_CHAR\_1** field, the parameter 1 is mapped to the **UDF\_CHAR\_2** field, the parameter 2 is mapped to the **UDF\_CHAR\_3** field, the parameter 3 is mapped to the **UDF\_CHAR\_4** field, the parameter 4 is mapped to the **UDF\_CHAR\_5** field, the paid date is mapped to the **UDF\_DATE\_1** field, and the **Pass Through without Markup or Markdown** pricing arrangement identifier is set to **PASS** in the **ANCILLARY** pricing rule type.

#### Example 4: Effective Pricing Rule is Defined Using a Pricing Group

In the example 4, the system considers the PR1 pricing rule for PI because of the following reasons:

- The paid date (i.e. 26-01-2018) of the ancillary transaction falls within the PR1 pricing rule's date range (i.e. 01-01-2018 to 31-12-2018).
- The employee attributes specified in the ancillary transaction match the criteria defined in the Rule 1 (i.e. Source System = X, Parameter 1 = Western, Parameter 2 = Indian, Parameter 3 = HR, and Parameter 4 = Permanent).
- The pricing arrangement is set to **Pass Through without Markup or Markdown** within Rule 1 of the PR1 pricing rule.

The system then stores the pricing group rule which is satisfied against a parameter which is defined in the **Pricing Group Rule Parameter** option type of the **C1-ASOBLLNG** feature configuration. In such case, the price item parameter group contains the price item parameters and the pricing group rule parameter. For example, Group A contains **BCHGLINETYPE = BC1**, **PRICINGARRANGEMENT = PASS**, and **Pricing Group Rule Parameter = Rule 1**.

In the example 4, the system could find the exact match for pricing parameters defined in the pricing group rule. However, if the exact match is not available, the system finds the effective pricing rule using the best fit match for the pricing parameters defined in the pricing group rule. Note that the system searches for the exact match in the effective pricing rules at both the bill group and parent customer levels. If the exact match is not available at both the levels, the system finds the effective pricing rule using the best fit match for the pricing parameters (defined in the pricing group rule) first at the bill group level and then at the parent customer level.

Let us understand this with the help of an example. An ancillary transaction is received with the following details:

- **UDF\_CHAR\_1** is set to X
- **UDF\_CHAR\_2** is set to Western
- **UDF\_CHAR\_3** is set to Indian
- **UDF\_CHAR\_4** is set to HR
- **UDF\_CHAR\_5** is set to Permanent
- **UDF\_CHAR\_6** is set to BC1
- **UDF\_CHAR\_7** is set to PASS

- UDF\_DATE\_1 is set to 31-05-2018
- Transaction Record Type is set to TR6

Let us assume that the following pricing structure is defined in the system:

Transaction Record Type	Primary Pricing Rule Type	Price Item	Price Item Parameters	Pricing Rule	Pricing Start Date	Pricing End Date	Pricing Group	Pricing Group Rule	Pricing Arrangement
TR6	ANCILLARY	PP1	BCHGLINETYPE = UDF_CHAR_6 and PRICINGARRANGEMENT = UDF_CHAR_7	PR1	01-01-2018	31-12-2018	PG1	Rule 1 (where Source System = X and Parameter 1 = Western)	Pass Through without Markup or Markdown
								Rule 1 (where Source System = X and Parameter 1 = Western)	Pass Through without Markup or Markdown
								Rule 2 (where Source System = X and Parameter 1 = Eastern)	Pass Through without Markup or Markdown
								Rule 2 (where Source System = X and Parameter 1 = Eastern)	Pass Through without Markup or Markdown
		PP2		PR2	01-01-2018	31-12-2018	PG2	Rule 1 (where Source System = X, Parameter 1 = Eastern, Parameter 2 = Indian, Parameter 3 = HR, and Parameter 4 = Permanent)	Pass Through without Markup or Markdown

Transaction Record Type	Primary Pricing Rule Type	Price Item	Price Item Parameters	Pricing Rule	Pricing Start Date	Pricing End Date	Pricing Group	Pricing Group Rule	Pricing Arrangement
								Rule 1 (where Source System = X, Parameter 1 = Eastern, Parameter 2 = Indian, Parameter 3 = HR, and Parameter 4 = Permanent)	Pass Through without Markup or Markdown
								Rule 2 (where Source System = X, Parameter 1 = Western, Parameter 2 = Indian, Parameter 3 = HR, and Parameter 4 = Permanent)	Pass Through without Markup or Markdown
								Rule 2 (where Source System = X, Parameter 1 = Western, Parameter 2 = Indian, Parameter 3 = HR, and Parameter 4 = Permanent)	Pass Through without Markup or Markdown

**Note:** Here, the source system is mapped to the **UDF\_CHAR\_1** field, the parameter 1 is mapped to the **UDF\_CHAR\_2** field, the parameter 2 is mapped to the **UDF\_CHAR\_3** field, the parameter 3 is mapped to the **UDF\_CHAR\_4** field, the parameter 4 is mapped to the **UDF\_CHAR\_5** field, the paid date is mapped to the **UDF\_DATE\_1** field, and the **Pass Through without Markup or Markdown** pricing arrangement identifier is set to **PASS** in the **ANCILLARY** pricing rule type.

#### Example 5: Effective Pricing Rule Derivation Using Best Fit Match for Pricing Parameters

In the example 5, the system could not find the exact match for the pricing parameters (i.e. Source System = X, Parameter 1 = Western, Parameter 2 = Indian, Parameter 3 = HR, and Parameter 4 = Permanent) in the effective pricing rule for PP1. Therefore, the system searches for the best fit match. While searching for the best fit match, the system rules out the optional parameter 4 (i.e. Parameter 4 = Permanent) and then checks whether the pricing group rule where Source System = X, Parameter 1 = Western, Parameter 2 = Indian, and Parameter 3 = HR exists in the effective pricing rule. If so, it considers the pricing group rule for further processing. If not, the system then rules out the optional parameter

3 (i.e. Parameter 3 = HR) and then checks whether the pricing group rule where Source System = X, Parameter 1 = Western, and Parameter 2 = Indian exists in the effective pricing rule. If so, it considers the pricing group rule for further processing. If not, the system then rules out the optional parameter 2 (i.e. Parameter 2 = Indian) and then checks whether the pricing group rule where Source System = X and Parameter 1 = Western exists in the effective pricing rule. If so, it considers the pricing group rule for further processing. If not, the status of the transaction is changed to **Error**.

In the example 5, the system considers Rule 1 where Source System = X and Parameter 1 = Western as the best fit match in the PR1 pricing rule for PP1. In addition, the pricing arrangement is set to **Pass Through without Markup or Markdown** within Rule 1 of the PR1 pricing rule. Therefore, the system fetches PR1 as the effective pricing rule for PP1. In addition, the system fetches PR2 as the effective pricing rule for PP2. The system creates two price item parameter groups — One contains BCHGLINETYPE = BC1, PRICINGARRANGEMENT = PASS, and Pricing Group Rule Parameter = Rule 1 and another contains BCHGLINETYPE = BC1, PRICINGARRANGEMENT = PASS, and Pricing Group Rule Parameter = Rule 2. Once the price item parameter group is created, the system creates the aggregation parameter group. An aggregation parameter group contains all price item parameters included in the related pricing rule type for which the parameter usage is set to **Aggregation**.

If the effective pricing rule is not derived for a price item and price item parameters combination or if the account or active contract for the account is not derived, the system does not create a transaction leg for the respective price item. Let us understand this with the help of an example:

Primary Pricing Rule Type	Price Item	Price Item Parameters	Effective Pricing Rule	Account	Active Contract	Transaction Leg
ANCILLARY	PP11	BCHGLINETYPE = UDF_CHAR_6 and PRICINGARRANGEMENT = UDF_CHAR_7	-	-	-	-
	PP12		PR12	A1	C1	TL11
	PP13		PR13	-	-	-
	PP14		PR14	A2	-	-
	PP15		PR15	-	-	-
	PP16		-	-	-	-
	PP17		PR17	A2	C2	TL12

#### Example 6: No. of Transaction Legs Derived

In the example 6, the system could not find the effective pricing rule for PP11 and PP16, the required account for PP13 and PP15, and the active contract for PP14 on A2. Therefore, in this case, the system creates two transaction legs — TL11 and TL12 for the transaction.

If the eligibility rule type is defined of a price item, the system maps the ancillary transaction to the price item only when the eligibility rule is satisfied. If the eligibility rule is not satisfied, the system does not consider the price item for billing. For example,

Price Item	Eligibility Criteria Met	Effective Pricing Rule	Account	Active Contract	Transaction Leg
PE1	Yes	PR1	A1	C1	TL1
PE2	-	PR2	-	-	-
PE3	No	-	-	-	-
PE4	Yes	-	-	-	-
PE5	Yes	PR3	A2	-	-
PE6	Yes	PR4	-	-	-

#### Example 7: Price Item Eligibility for Transaction Leg Derivation



In the example 7, the eligibility criteria was defined for PE1, PE3, PE4, PE5, and PE6. The eligibility criteria was satisfied for PE1, PE4, PE5, and PE6, but not for PE3. Further, the system could not find the effective pricing rule for PE4, the required account for PE2 and PE6, and the active contract for PE5 on A2. Therefore, in this case, the system creates one transaction leg (i.e. TL1) for the ancillary transaction. For more information, refer to the [Price Item Eligibility](#) on page 2726 section.

Once a transaction leg is created, the derivation date is set as the processing date corresponding to the transaction leg.

## Bill After Date Determination

Once the billable charges are created for claim, claim based fees, enrollment based fees, and ancillary, the system enables you to automatically stamp the bill after date in these billable charges. The system can automatically stamp the bill after date in these billable charges only when an algorithm created using the **C1\_BAFTDRV** algorithm type is attached to the **Bill After Date Determination** system event of the respective pricing rule type. This algorithm sets the bill after date to the end date of the aggregation schedule period in which the transaction date falls. Note that the system considers the aggregation schedule specified in the rate option which is defined for the respective price item. Let us understand this with the help of an example. If the claim transaction with the transaction date set to 25-06-2018 is mapped to the following price item and account combinations:

Pricing Rule Type	Price Item	Rate Option	Aggregate Transaction	Aggregation Schedule	Schedule Period	Account	Billable Charge	
CLAIM	P1	R01	Yes	Monthly	01-01-2018 — 31-01-2018	A1	BC1	
					01-02-2018 — 28-02-2018			
					01-03-2018 — 31-03-2018			
					01-04-2018 — 30-04-2018			
					01-05-2018 — 31-05-2018			
					01-06-2018 — 30-06-2018			
					01-07-2018 — 31-07-2018			
					01-08-2018 — 31-08-2018			
	P2	R01				01-09-2018 — 30-09-2018	A2	BC2
						01-10-2018 — 31-10-2018		

Pricing Rule Type	Price Item	Rate Option	Aggregate Transaction	Aggregation Schedule	Schedule Period	Account	Billable Charge
					01-11-2018 — 30-11-2018		
					01-12-2018 — 31-12-2018		
	P3	R02	Yes	Yearly	01-01-2018 — 31-12-2018	A3	BC3

#### Example 1: Bill After Date Determination Using the Aggregation Schedule

In the example 1, the system stamps 30-06-2018 as the bill after date in the BC1 and BC2 billable charges. This is because the transaction date (i.e. 25-06-2018) falls in the 01-06-2018 — 30-06-2018 period of the R01 aggregation schedule.

However, the system stamps 31-12-2018 as the bill after date in the BC3 billable charge. This is because the transaction date (i.e. 25-06-2018) falls in the 01-01-2018 — 31-12-2018 period of the R02 aggregation schedule.

**Note:** The bill after date for the specific stop-loss and aggregate stop-loss billable charges is calculated using the settlement frequency in the **Create Specific Stop-Loss Billable Charge (C1-BCSSL)** and **Create Aggregate Stop-Loss Billable Charge (C1-BCASL)** batches, respectively.

---

# Chapter

# 34

---

## Fully-Insured Pricing

---

### Topics:

- [Age Based Pricing](#)
- [Tier Based Pricing](#)
- [Pass-Through Billable Charge](#)

A new pricing model is introduced for the fully-insured business. In this pricing model, you can define pricing rules using the pricing rule types. At present, you can define the following pricing rule types for the fully-insured business:

- Age Based Pricing Rule Type
- Tier Based Pricing Rule Type
- Pass-Through Billable Charge Pricing Rule Type

**Note:** You cannot define pricing rules using the pass-through billable charge pricing rule types. However, you can directly create SQI based billable charges using a pass-through billable charge pricing rule type. For more information, refer to the [Pass-Through Billable Charge](#) on page 2819 section.

## Age Based Pricing

---

The base fee for a price item can vary based on the age, employee attributes (such as employee type, employee status, etc.) and modifiers (such as tobacco usage, gender, alcohol usage, etc.). Oracle Revenue Management and Billing enables you to offer an age based pricing to a fully-insured customer. In the Age Based pricing, the premium is calculated for each eligible member person based on age, employee attributes and modifiers, and then aggregated to derive the total premium for the membership. An age based pricing can be defined using the age based pricing rule. You can define an age based pricing rule for a price item on the policy plan. If the age based pricing rule is defined for a price item on a policy plan, all memberships which belong to the policy plan will inherit the age based pricing from the policy plan. If the system does not find any effective pricing rule for a price item on the policy plan, it inherits the effective pricing rule for the price item from the parent customer level.

You can define an age based pricing rule using an age based pricing rule type. It is the age based pricing rule type which helps the system to determine:

- Business object using which the age based pricing rule should be created in the system.
- Algorithm which should be triggered for deriving the bill group, parent customer, and policy for a membership.

**Note:** You must create an algorithm using the **C1\_MEMBGDRV** algorithm type and attach it to the **Bill Group Derivation** system event.

- Algorithm which should be triggered for deriving the account and price item for a membership.

**Note:** You must create an algorithm using the **C1\_ACCPRIMEM** algorithm type and attach it to the **Account and Price Item Derivation** system event.

- Algorithm which should be triggered for identifying eligible member persons for premium calculation.

**Note:** You must create an algorithm using the **C1\_AGEDELG** algorithm type and attach it to the **Pricing Rule Pre Processing** system event.

- Algorithm which should be triggered for calculating the premium for each eligible member person.

**Note:** You must create an algorithm using the **C1\_AGEPREM** algorithm type and attach it to the **Pricing Rule Premium Calculation** system event.

- Algorithm which should be triggered for deriving the bill period for the account.

**Note:** You must create an algorithm using the **C1-FIBCBP** algorithm type and attach it to the **Pricing Rule BC Creation Pre Processing** system event.

- Algorithm which should be triggered for creating the SQI based billable charges for each membership and price item combination.

**Note:** You must create an algorithm using the **C1-FICRETBC** algorithm type and attach it to the **Pricing Rule Billable Charge Creation** system event.

- Price items for which you can define age based pricing rules using the age based pricing rule type.
- Rate options that you can use while defining the pricing for the respective price item.
- Type of account to which the respective price item should be billed based on the specified priority.
- Rule type which indicates the rules that should be executed to determine whether the price item is eligible for billing.
- Audit event types of the C1-Membership and C1-PERSON business objects using which the audit event should be created whenever a membership or member person is added, updated, or removed from the policy plan.

- Elements of the C1-Membership and C1-PERSON business objects for which audit event should be created.

**Note:** You must ensure that either the **Update All** option is selected or the elements listed in the age based pricing rule type are already present in the respective audit event type. Otherwise, erroneous results might occur.

- Members, such as main subscriber, spouse, or children in a membership which are eligible for premium calculation. The system will only consider the member with the specified relationship type during premium calculation.
- Characteristic types to identify a list of eligible children for premium calculation. The following characteristic types must be specified in the age based pricing rule type:
  - **Maximum Number of Dependents** – This characteristic type stores the maximum number of children which are eligible for premium calculation. You must specify a characteristic type where the characteristic entity is set to **Member Person, Membership, Policy Plan, Policy, and State**.
  - **Maximum Age Limit for Maximum Dependent Count** – This characteristic type stores the maximum age limit for children which are eligible for premium calculation. You must specify a characteristic type where the characteristic entity is set to **Member Person, Membership, Policy Plan, Policy, and State**.
  - **Maximum Number of Dependents Order Priority** – This characteristic type indicates whether the youngest or eldest children should be considered during premium calculation. You must specify a characteristic type where the characteristic entity is set to **Member Person, Membership, Policy Plan, Policy, and State**.
  - **Age Calculation Date Basis** – This characteristic type indicates whether the member person's age should be calculated using the member person's enrollment date or policy's start or renewal date. You must specify a characteristic type where the characteristic entity is set to **Member Person, Membership, Policy Plan, Policy, and State**.
  - **Newborn Gift Days** – This characteristic type stores the number of days you want to offer as gift days from the new born child's enrollment date. You must specify a characteristic type where the characteristic entity is set to **Member Person, Membership, Policy Plan, Policy, and State**.
  - **Newborn Gift Days Applicability** – This characteristic type indicates whether the gift days should be offered in case of a new born. You must specify a characteristic type where the characteristic entity is set to **Member Person, Membership, Policy Plan, Policy, and State**.
  - **Young Adult Max Age Limit** – This characteristic type stores the maximum age limit for young adults which are eligible for premium calculation. You must specify a characteristic type where the characteristic entity is set to **Member Person, Membership, Policy Plan, Policy, and State**.
  - **Young Adult Inclusion Applicability** – This characteristic type indicates whether the young adults should be considered during the premium calculation. You must specify a characteristic type where the characteristic entity is set to **Member Person, Membership, Policy Plan, Policy, and State**.

Once an age based pricing rule type is defined, you can define age based pricing rules using the age based pricing rule type. Note that, at present, you can define age based pricing rules only through a healthcare inbound message and not from the user interface. However, you can view the age based pricing rules defined for a policy plan from the **Customer 360° Information** screen. While creating an age based pricing rule through a healthcare inbound message, you need to specify the following information:

- Entity type (i.e. Policy Plan) and entity ID (i.e. policy plan ID) for which you want to define the age based pricing rule
- Start and end dates of the age based pricing rule
- Age based pricing rule type using which you want to create the age based pricing rule
- Price Item for which you want to define age based pricing
- Rate option using which the price assignment should be created for the age based pricing rule

**Note:** If the rate option is not given in the pricing rule data, by default, it is set to a value specified in the **Default Rate Option – Flat** or **Default Rate Option – Percentage** option type of the **C1-ASOBLNG** feature configuration depending on whether the modifier method is set to **FLAT**, **EXPT** or **INPT**.

- Whether you want to increase or decrease the premium of an eligible member by a flat amount or in percentage based on some modifier attributes (such as tobacco usage, alcohol usage, and so on).
- Age limit and employee attributes for which the base fee is applicable

**Note:**

The system defines the lower age limit and upper age limit pricing eligibility criteria using the parameter which is specified in the **Age Based Parameter** option type of the **C1-ASOBLNG** feature configuration.

The employee attributes can be defined as the parameters in the system. These parameters can then be used to define eligibility criteria in the age based pricing. Here, you can use only those parameters where the parameter usage is set to **Pricing Eligibility**.

- Modifiers based on which you want to charge additional or offer discount to an eligible member

**Note:** The modifiers can be defined as the parameters in the system. These parameters can then be used to define eligibility criteria in the age based pricing. Here, you can use only those parameters where the parameter usage is set to **Pricing Eligibility**.

Once the age based pricing rule is defined for a policy plan, the system creates a price item pricing and price list and then assigns the price item pricing to the price list.

## Defining an Age Based Pricing Rule Type

### Prerequisites

To define an age based pricing rule type, you should have:

- Age based pricing rule type business object defined in the application.
- Age based pricing rule business object defined in the application.

### Procedure

To define an age based pricing rule type pricing rule type:

1. Click the **Admin** link in the **Application** toolbar.  
A list appears.
2. From the **Admin** menu, select **P** and then click **Pricing Rule Type**.  
A sub-menu appears.
3. Click the **Add** option from the **Pricing Rule Type** sub-menu.

The **Select Business Object** screen appears. It contains the following field:

Field Name	Field Description	Mandatory (Yes or No)
Pricing Rule Type Business Object	Used to indicate the business object using which you want to create a age based pricing rule type.  <b>Note:</b> You can create a age based pricing rule type using the <b>Age Based Pricing Rule Type (C1-PrcRuleTypeAgeBased)</b> business object.	Yes

**Tip:** Alternatively, you can access this screen by clicking the **Add** button in the **Page Title** area of the **Pricing Rule Type** screen.

4. Select the **Fully Insured Age Based Pricing Rule Type** option from the **Pricing Rule Type Business Object** list.
5. Click **OK**.

The **Fully Insured Age Based Pricing Rule Type** screen appears. It contains the following sections:

- **Main** – Used to specify basic details about an age based pricing rule type.
- **Algorithms** – Used to associate the algorithms with an age based pricing rule type.
- **Price Items** – Used to add the price items for which you can define the age based pricing rules using the age based pricing rule type.
- **Price Item Parameters** – Used to add the price item parameters based on which you want to define the price item pricing.
- **Characteristics** – Used to define the characteristics for an age based pricing rule type.
- **Event Management** – Used to configure the audit in an age based pricing rule type.
- **Age Based-Specific Additional Data** – Used to define age based-specific additional data in an age based pricing rule type.
- **Attributes Characteristic Mapping** – Used to map a characteristic attribute in an age based pricing rule type.

The **Main** section contains the following fields:

Field Name	Field Description	Mandatory (Yes or No)
Pricing Rule Type	Used to specify an age based pricing rule type.	Yes
Description	Used to specify the description for an age based pricing rule type.	Yes
Detailed Description	Used to specify additional information about an age based pricing rule type.	No
Pricing Rule Business Object	Used to indicate the business object using which you want to create an age based pricing rule type. The valid value is: <ul style="list-style-type: none"> <li>• Fully Insured Age Based Pricing Rule</li> </ul>	Yes
Business Object	Indicates the business object using which you are defining an age based pricing rule type.	Not applicable
Status	Used to indicate the status of an age based pricing rule type. The valid values are: <ul style="list-style-type: none"> <li>• Active</li> <li>• Inactive</li> </ul>	Yes
Pricing Rule Type Category	Used to indicate the category to which the pricing rule type belongs. The valid value is: <ul style="list-style-type: none"> <li>• Age Based</li> </ul>	Yes

6. Enter the required details in the **Main** section.
7. Associate the following algorithms with the age based pricing rule type:

System Event	Algorithm	Algorithm Type	Description
Bill Group Derivation	C1_MEMBGDRV	C1_MEMBGDRV	Bill Group Derivation for Membership
Account and Price Item Derivation	C1_ACCPRIMEM	C1_ACCPRIMEM	Account and PriceItem Derivation for Membership
Pricing Rule Pre Processing	C1_AGEBDELG	C1_AGEBDELG	Get eligible member details from membership.
Pricing Rule Premium Calculation	C1_AGEPREM	C1_AGEPREM	Age Based Premium Calculation
Pricing Rule BC Creation Pre Processing	C1-FIBCBP	C1-FIBCBP	Fetch Bill Period of Billable Charge of Membership
Pricing Rule Billable Charge Creation	C1-FICRETBC	C1-FICRETBC	Fully Insured Charge creation for memberships

8. Add the required price items in an age based pricing rule type.
9. Add the price item parameters in age based pricing rule type, if required.
10. Define characteristics for an age based pricing rule type, if required.
11. Configure the audit in an age based pricing rule type.
12. Define age based-specific additional data in an age based pricing rule type.
13. Map a characteristic attribute in an age based pricing rule type
14. Click **Save**.

The age based pricing rule type is defined.

### **Related Topics**

For more information on...	See...
How to associate algorithms with an age based pricing rule type	<a href="#">Associating an Algorithm with an Age Based Pricing Rule Type</a> on page 2792
How to add price items in an age based pricing rule type	<a href="#">Adding a Price Item in an Age Based Pricing Rule Type</a> on page 2794
How to add price item parameters in an age based pricing rule type	<a href="#">Adding a Price Item Parameter in an Age Based Pricing Rule Type</a> on page 2797
How to define characteristics for an age based pricing rule type	<a href="#">Defining Characteristics for an Age Based Pricing Rule Type</a> on page 2798
How to add elements for audit in an age based pricing rule type	<a href="#">Adding Elements for Audit in an Age Based Pricing Rule Type</a> on page 2799
How to define additional data in an age based-specific additional data in an age based pricing rule type	<a href="#">Defining Additional Data in an Age Based Pricing Rule Type</a> on page 2800

## **Associating an Algorithm with an Age Based Pricing Rule Type**

### **Prerequisites**

To associate algorithm with an age based pricing rule type, you should have:



- An algorithm defined using the **C1\_MEMBGDRV** algorithm type.
- An algorithm defined using the **C1\_ACCPRIMEM** algorithm type.
- An algorithm defined using the **C1\_AGEBDELG** algorithm type.
- An algorithm defined using the **C1\_AGEPREM** algorithm type.
- An algorithm defined using the **C1-FIBCBP** algorithm type.
- An algorithm defined using the **C1-FICRETBC** algorithm type.



### Procedure

To associate algorithms with a fully-insured age based pricing rule type:

1. Ensure that the **Algorithms** section is expanded when you are defining or editing the age based pricing rule type.

The **Algorithms** section contains the following columns in a grid:

Column Name	Column Description	Mandatory (Yes or No)
System Event	Used to indicate the system event when you want to invoke the algorithm. The valid values are: <ul style="list-style-type: none"> <li>• <b>Bill Group Derivation</b> - Used to derive the bill group, parent customer, and policy for a membership.</li> <li>• <b>Account and Price Item Derivation</b> - Used to derive the account and price item for a membership.</li> <li>• <b>Pricing Rule Pre Processing</b> - Used to identify the eligible member persons for premium calculation.</li> <li>• <b>Pricing Rule Premium Calculation</b> - Used to calculate the premium for each eligible member person.</li> <li>• <b>Pricing Rule BC Creation Pre Processing</b> - Used to derive the bill period for the account.</li> <li>• <b>Pricing Rule Billable Charge Creation</b> - Used to derive the price items for which you can create the SQI based billable charges using the pass-through billable charge pricing rule type.</li> </ul>	Yes  <b>Note:</b> This field is required when you are associating an algorithm with the age based pricing rule type.
Sequence	Used to specify the order in which the algorithms for each system event must be executed.	Yes (Conditional)  <b>Note:</b> This field is required when you are associating an algorithm with the fully-insured age based pricing rule type.

Column Name	Column Description	Mandatory (Yes or No)
Algorithm	Used to specify the algorithm.  <b>Note:</b> Once you select the system event, the <b>Search</b>  icon appears corresponding to the <b>Algorithm</b> field. On clicking the <b>Search</b>  icon, the <b>Algorithm Search</b> window appears.  On specifying the algorithm, the description of the algorithm appears corresponding to the <b>Algorithm</b> field.	Yes (Conditional)  <b>Note:</b> This field is required when you are associating an algorithm with the fully-insured age based pricing rule type.

2. Enter the following details in the **Algorithms** section:

System Event	Algorithm	Algorithm Type	Description
Bill Group Derivation	C1_MEMBGDRV	C1_MEMBGDRV	Bill Group Derivation for Membership
Account and Price Item Derivation	C1_ACCPRIMEM	C1_ACCPRIMEM	Account and PriceItem Derivation for Membership
Pricing Rule Pre Processing	C1_AGEBDELG	C1_AGEBDELG	Get eligible member details from membership.
Pricing Rule Premium Calculation	C1_AGEPREM	C1_AGEPREM	Age Based Premium Calculation
Pricing Rule BC Creation Pre Processing	C1-FIBCBP	C1-FIBCBP	Fetch Bill Period of Billable Charge of Membership
Pricing Rule Billable Charge Creation	C1-FICRETBC	C1-FICRETBC	Fully Insured Charge creation for Memberships

3. If you want to associate more than one algorithm with the age based pricing rule type, click the **Add**  icon and then repeat step 2.

**Note:** However, if you want to disassociate an algorithm from the age based pricing rule type, click the **Delete**  icon corresponding to the algorithm.

4. Click **Save**.

The algorithms are associated with the age based pricing rule type.

### **Related Topics**

For more information on...	See...
How to define an age based pricing rule type	<a href="#">Defining an Age Based Pricing Rule Type</a> on page 2790
How to edit an age based pricing rule type	<a href="#">Editing an Age Based Pricing Rule Type</a> on page 2801

## **Adding a Price Item in an Age Based Pricing Rule Type**

### **Prerequisites**

To add a price item in an age based pricing rule type, you should have:





- Price item defined in the application
- Rate option defined in the **Rate Option (C1-ExtLookRefTypeRateOpt)** extendable lookup
- Values defined for the **Invoice Type (C1INVTYP)** characteristic type
- The **C1INVTYP** characteristic type set in the **Invoice Type Characteristic Type** option type of the **C1-ASOBLNG** feature configuration
- Rule types defined in the application (where the rule type usage is set to **Price Item Eligibility**)





### Procedure

To add a price item in an age based pricing rule type:

1. Ensure that the **Price Items** section is expanded when you are defining or editing an age based pricing rule type.

The **Price Items** section contains the following fields in a grid:

Field Name	Field Description	Mandatory (Yes or No)						
Price Item	<p>Used to indicate the price item that you want to include in the age based pricing rule type.</p> <p><b>Note:</b> The <b>Search</b> () icon appears corresponding to the <b>Price Item</b> field. On clicking the <b>Search</b> icon, the <b>Price Item Search</b> window appears. On specifying the price item, the description of the price item appears corresponding to the <b>Price Item</b> field.</p>	<p>Yes (Conditional)</p> <p><b>Note:</b> This field is required when you are adding a rate option and bill to account in an age based pricing rule type.</p>						
Rate Option	<p>Used to indicate one or more rate options which are valid for a price item.</p> <p>On clicking the <b>Add</b> () icon, the following field appears in a grid:</p> <table border="1"> <thead> <tr> <th>Field Name</th> <th>Field Description</th> <th>Mandatory (Yes or No)</th> </tr> </thead> <tbody> <tr> <td>Rate Option</td> <td>Used to indicate the rate option that you want to use while defining pricing for the price item.</td> <td>Yes</td> </tr> </tbody> </table> <p><b>Note:</b> If you want to define more than one rate option to the price item in an age based pricing rule type, click the <b>Add</b> () icon. However, if you want to remove a price item from an age based pricing rule type, click the <b>Delete</b> () icon corresponding to the <b>Rate Option</b> field.</p>	Field Name	Field Description	Mandatory (Yes or No)	Rate Option	Used to indicate the rate option that you want to use while defining pricing for the price item.	Yes	Not applicable
Field Name	Field Description	Mandatory (Yes or No)						
Rate Option	Used to indicate the rate option that you want to use while defining pricing for the price item.	Yes						

Field Name	Field Description	Mandatory (Yes or No)									
Bill To Account	<p>Used to indicate a order in which the account should be considered while deriving a transaction leg.</p> <p>On clicking the <b>Add</b> () icon, the following fields appear in a grid:</p> <table border="1"> <thead> <tr> <th>Field Name</th> <th>Field Description</th> <th>Mandatory (Yes or No)</th> </tr> </thead> <tbody> <tr> <td>Priority</td> <td>Used to specify the order in which the invoice type is considered for a price item.</td> <td>Yes</td> </tr> <tr> <td>Invoice Type</td> <td>Used to indicate the type which is considered for billing. For more information, refer to the <i>Bill Group's Account</i> on page 55 section.</td> <td>Yes</td> </tr> </tbody> </table> <p><b>Note:</b> The <b>Search</b> () icon appears corresponding to the <b>Invoice Type</b> field. On clicking the <b>Search</b> icon, the <b>Invoice Type Search</b> window appears.</p> <p><b>Note:</b> If you want to define more than one invoice type to the price item in an age based pricing rule type, click the <b>Add</b> () icon. However, if you want to remove a invoice type from the price item in an age based pricing rule type, click the <b>Delete</b> () icon corresponding to the <b>Priority</b> field.</p>	Field Name	Field Description	Mandatory (Yes or No)	Priority	Used to specify the order in which the invoice type is considered for a price item.	Yes	Invoice Type	Used to indicate the type which is considered for billing. For more information, refer to the <i>Bill Group's Account</i> on page 55 section.	Yes	Not applicable
Field Name	Field Description	Mandatory (Yes or No)									
Priority	Used to specify the order in which the invoice type is considered for a price item.	Yes									
Invoice Type	Used to indicate the type which is considered for billing. For more information, refer to the <i>Bill Group's Account</i> on page 55 section.	Yes									
Eligibility Rule Type	Used to indicate the rule type (which indicates the rules) that should be executed to determine whether the price item is eligible for billing.	No									

- Enter the required details in the **Price Items** section.
- If you want to define more than one price item in an age based pricing rule type, click the **Add** () icon and then repeat step 2.

**Note:** However, if you want to remove a price item from an age based pricing rule type, click the **Delete** () icon corresponding to the **Price Item** field.

- Click **Save**.

The price items are added for an age based pricing rule type.

### Related Topics

For more information on...	See...
How to define an age based pricing rule type	<a href="#">Defining an Age Based Pricing Rule Type</a> on page 2790

For more information on...	See...
How to edit an age based pricing rule type	<a href="#">Editing an Age Based Pricing Rule Type</a> on page 2801

## Adding a Price Item Parameter in an Age Based Pricing Rule Type

### Prerequisites

To add a price item parameter in an age based pricing rule type, you should have:

- Parameter defined in the application where parameter usage is set to **Price Item**.
- Parameter associated with the price item.

### Procedure

To add a price item parameter in an age based pricing rule type:

1. Ensure that the **Price Item Parameters** section is expanded when you are defining or editing an age based pricing rule type.

The **Price Item Parameters** section contains the following fields in a grid:

Field Name	Field Description	Mandatory (Yes or No)
Price Item Parameter	Used to specify the parameter which you can use while defining an age based pricing for the price item.  <b>Note:</b> The <b>Search</b> (🔍) icon appears corresponding to the <b>Price Item Parameter</b> field. On clicking the <b>Search</b> (🔍) icon corresponding to the <b>Price Item Parameter</b> field, the <b>Parameter Search</b> window appears.  On specifying the parameter, the description of the price item parameter appears corresponding to the <b>Price Item Parameter</b> field.	Yes (Conditional)  <b>Note:</b> This field is required when you are adding a price item parameter in an age based pricing rule type.

2. Enter the required details in the **Price Item Parameters** section.
3. If you want to add more than one price item parameter in an age based pricing rule type, click the **Add** (+) icon and then repeat step 2.

**Note:** However, if you want to remove a price item parameter from an age based pricing rule type, click the **Delete** (🗑️) icon corresponding to the price item parameter.

4. Click **Save**.

The price item parameter is added for an age based pricing rule type.

### Related Topics

For more information on...	See...
How to define an age based pricing rule type	<a href="#">Defining an Age Based Pricing Rule Type</a> on page 2790
How to edit an age based pricing rule type	<a href="#">Editing an Age Based Pricing Rule Type</a> on page 2801

## Defining Characteristics for an Age Based Pricing Rule Type

### Prerequisites

To define characteristics for an age based pricing rule type, you should have:

- Characteristic types defined in the application (where the characteristic entity is set to **Pricing Rule Type**)

### Procedure

To define characteristics for an age based pricing rule type:

1. Ensure that the **Characteristics** section is expanded when you are defining or editing an age based pricing rule type.

The **Characteristics** section contains the following columns in a grid:

Field Name	Field Description	Mandatory (Yes or No)
Characteristic Type	Used to indicate the characteristic type.  <b>Note:</b> The list includes only those characteristic types where the characteristic entity is set to <b>Pricing Rule Type</b> .	Yes (Conditional)  <b>Note:</b> This field is required when you are defining a characteristic for an age based pricing rule type.
Characteristic Value	Used to specify the value for the characteristic type.  <b>Note:</b> If you select a predefined characteristic type, the <b>Search</b>  icon appears corresponding to the <b>Characteristic Value</b> field. On clicking the <b>Search</b> icon, the <b>Predefined Characteristic Search</b> window appears.  On specifying the value for a predefined characteristic type, the description of the characteristic value appears corresponding to the <b>Characteristic Value</b> field.	Yes (Conditional)  <b>Note:</b> This field is required when you are defining a characteristic for an age based pricing rule type.

2. Enter the required details in the **Characteristics** section.
3. If you want to define more than one characteristic for an age based pricing rule type, click the **Add**  icon and then repeat step 2.

**Note:** However, if you want to remove a characteristic from an age based pricing rule type, click the **Delete**  icon corresponding to the characteristic.

4. Click **Save**.

The characteristics are defined for an age based pricing rule type.

### Related Topics

For more information on...	See...
How to define an age based pricing rule type	<a href="#">Defining an Age Based Pricing Rule Type</a> on page 2790

For more information on...	See...
How to edit an age based pricing rule type	<a href="#">Editing an Age Based Pricing Rule Type</a> on page 2801

## Adding Elements for Audit in an Age Based Pricing Rule Type

### Prerequisites

To add elements for audit in an age based pricing rule type, you should have:

- Business Object **C1-AuditEventType** defined for the pricing rule type.
- Audit Event Type defined in the application.

### Procedure

To add elements for audit in an age based pricing rule type:

1. Ensure that the **Event Management** section is expanded when you are defining or editing an age based pricing rule type.

The **Event Management** section contains the following fields in a grid:

Field Name	Field Description	Mandatory (Yes or No)
Audit Event Type	Used to specify the audit event type which you can use while adding elements for audit in an age based pricing rule type.  <b>Note:</b> The <b>Search</b> (🔍) icon appears corresponding to the <b>Audit Event Type</b> field. On clicking the <b>Search</b> (🔍) icon corresponding to the <b>Audit Event Type</b> field, the <b>Audit Event Type Search</b> window appears.  On specifying the audit event type, the description of the audit event type appears corresponding to the <b>Audit Event Type</b> field.	Yes
Element Type	Used to indicate the type of audit element for an age based pricing rule type. The valid values are: <ul style="list-style-type: none"> <li>• Business Object Status</li> <li>• Characteristic</li> <li>• Field</li> </ul>	Not applicable
Element Name	Used to specify the element name for an age based pricing rule type.  <b>Note:</b> The <b>Search</b> (🔍) icon appears corresponding to the <b>Element Name</b> field. On clicking the <b>Search</b> (🔍) icon corresponding to the <b>Element Name</b> field, the <b>Audit Event Type Element Name Search</b> window appears.	Yes
Element Value	Used to specify the value for an element name.	Not applicable

- Enter the required details in the **Price Item Parameters** section.
- If you want to add more than one price item parameter in an age based pricing rule type, click the **Add** (+) icon and then repeat step 2.

**Note:** However, if you want to remove a price item parameter from an age based pricing rule type, click the **Delete** (🗑️) icon corresponding to the price item parameter.

- Click **Save**.

The price item parameter is added for an age based pricing rule type.

### **Related Topics**

For more information on...	See...
How to define an age based pricing rule type	<a href="#">Defining an Age Based Pricing Rule Type</a> on page 2790
How to edit an age based pricing rule type	<a href="#">Editing an Age Based Pricing Rule Type</a> on page 2801

## **Defining Additional Data in an Age Based Pricing Rule Type**

### **Procedure**

To define additional data in an age based pricing rule type:

- Ensure that the **Age Based - Specific Additional Data** section is expanded when you are defining or editing an age based pricing rule type.

The **Age Based - Specific Additional Data** section contains the following fields:

Field Name	Field Description	Mandatory (Yes or No)
Relation	Used to indicate the relation of the member in an age based pricing rule type. The valid values are: <ul style="list-style-type: none"> <li>Children</li> <li>Main Subscriber</li> <li>Spouse</li> </ul>	No
Relationship Type	Used to indicate the type of relationship for an age based pricing rule type.	No

- Enter the required details in the **Additional Data** section.
- If you want to add more than one age based specific data in an age based pricing rule type, click the **Add** (+) icon and then repeat step 2.

**Note:** However, if you want to remove an age based specific data from an age based pricing rule type, click the **Delete** (🗑️) icon corresponding to the **Relation** field.

- Click **Save**.

The age based - specific additional data is defined for the age based pricing rule type.

### **Related Topics**



For more information on...	See...
How to define an age based pricing rule type	<a href="#">Defining an Age Based Pricing Rule Type</a> on page 2790
How to edit an age based pricing rule type	<a href="#">Editing an Age Based Pricing Rule Type</a> on page 2801

## Editing an Age Based Pricing Rule Type

### Prerequisites

To edit an age based pricing rule type, you should have:

- Age Based pricing rule type business object defined in the application.
- Age Based pricing rule business object defined in the application.

### Procedure

To edit an age based pricing rule type:

1. Click the **Admin** link in the **Application** toolbar.  
A list appears.
2. From the **Admin** menu, select **P** and then click **Pricing Rule Type**.  
A sub-menu appears.
3. Click the **Search** option from the **Pricing Rule Type** sub-menu.  
The **Pricing Rule Type** screen appears.
4. In the **Pricing Rule Type List** zone, click the **Edit** (✎) icon in the **Edit** column corresponding to the pricing rule type whose details you want to edit.

The **Fully Insured Age Based Pricing Rule Type** screen appears. It contains the following sections:

- **Main** – Used to specify basic details about an age based pricing rule type.
- **Algorithms** – Used to associate the algorithms with an age based pricing rule type.
- **Price Items** – Used to add the price items for which you can define the age based pricing rules using the age based pricing rule type.
- **Price Item Parameters** – Used to add the price item parameters based on which you want to define the price item pricing.
- **Characteristics** – Used to define characteristics for an age based pricing rule type.
- **Event Management** – Used to configure the audit in an age based pricing rule type.
- **Age Based-Specific Additional Data** – Used to define age based-specific additional data in an age based pricing rule type.
- **Attributes Characteristic Mapping** – Used to map a characteristic attribute in an age based pricing rule type.

The **Main** section contains the following fields:

Field Name	Field Description	Mandatory (Yes or No)
Pricing Rule Type	Displays the age based pricing rule type.	Not applicable
Description	Used to specify the description for an age based pricing rule type.	Yes

Field Name	Field Description	Mandatory (Yes or No)
Detailed Description	Used to specify additional information about an age based pricing rule type.	No
Pricing Rule Business Object	Used to indicate the business object using which you want to create an age based pricing rule type. The valid value is: <ul style="list-style-type: none"> <li>Fully Insured Age Based Pricing Rule</li> </ul>	Yes
Business Object	Indicates the business object using which you are defining an age based pricing rule type.	Not applicable
Status	Used to indicate the status of an age based pricing rule type. The valid values are: <ul style="list-style-type: none"> <li>Active</li> <li>Inactive</li> </ul>	Yes
Pricing Rule Type Category	Indicates the pricing rule type category for an age based pricing rule type. The valid values is: <ul style="list-style-type: none"> <li>Age Based</li> </ul>	No

**Tip:** Alternatively, you can edit the details of an age based pricing rule type by clicking the **Edit** button in the **Pricing Rule Type** zone.

- Modify the details in the **Main** section.
- Associate the following algorithms with the age based pricing rule type:

System Event	Algorithm	Algorithm Type	Description
Bill Group Derivation	C1_MEMBGDRV	C1_MEMBGDRV	Bill Group Derivation for Membership
Account and Price Item Derivation	C1_ACCPRIMEM	C1_ACCPRIMEM	Account and PriceItem Derivation for Membership
Pricing Rule Pre Processing	C1_AGEBDELG	C1_AGEBDELG	Get Eligible Member Details from Membership
Pricing Rule Premium Calculation	C1_AGEPREM	C1_AGEPREM	Age Based Premium Calculation
Pricing Rule BC Creation Pre Processing	C1-FIBCBP	C1-FIBCBP	Fetch Bill Period of Billable Charge of Membership
Pricing Rule Billable Charge Creation	C1-FICRETBC	C1-FICRETBC	Fully Insured Charge creation for memberships

- Add, edit, or remove the required price items in an age based pricing rule type.
- Add, edit, or remove the price item parameters in an age based pricing rule type, if required.
- Add, edit, or remove characteristics for an age based pricing rule type, if required.
- Add, edit, or remove the configuration details of the audit in an age based pricing rule type.
- Add, edit, or remove the age based-specific additional data in an age based pricing rule type.
- Add, edit, or remove a characteristic attribute in an age based pricing rule type

**13. Click Save.**

The changes made to the age based pricing rule type are saved.

**Related Topics**

For more information on...	See...
How to associate algorithms with an age based pricing rule type	<a href="#">Associating an Algorithm with an Age Based Pricing Rule Type</a> on page 2792
How to add price items in an age based pricing rule type	<a href="#">Adding a Price Item in an Age Based Pricing Rule Type</a> on page 2794
How to add price item parameters in an age based pricing rule type	<a href="#">Adding a Price Item Parameter in an Age Based Pricing Rule Type</a> on page 2797
How to define characteristics for an age based pricing rule type	<a href="#">Defining Characteristics for an Age Based Pricing Rule Type</a> on page 2798
How to add elements for audit in an age based pricing rule type	<a href="#">Adding Elements for Audit in an Age Based Pricing Rule Type</a> on page 2799
How to define additional data in an age based-specific additional data in an age based pricing rule type	<a href="#">Defining Additional Data in an Age Based Pricing Rule Type</a> on page 2800

**Deleting an Age Based Pricing Rule Type****Procedure**

To delete an age based pricing rule type:

1. Click the **Admin** link in the **Application** toolbar.  
A list appears.
2. From the **Admin** menu, select **P** and then click **Pricing Rule Type**.  
A sub-menu appears.
3. Click the **Search** option from the **Pricing Rule Type** sub-menu.  
The **Pricing Rule Type** screen appears.
4. In the **Pricing Rule Type List** zone, click the **Delete** (🗑️) icon in the **Delete** column corresponding to the age based pricing rule type that you want to delete.  
A message appears confirming whether you want to delete the age based pricing rule type.

**Note:** You can delete an age based pricing rule type only when it is not yet used in the system.

**Tip:** Alternatively, you can delete an age based pricing rule type by clicking the **Delete** button in the **Pricing Rule Type** zone.

5. Click **OK**.

The age based pricing rule type is deleted.

**Related Topics**

For more information on...	See...
<b>Pricing Rule Type</b> screen	<a href="#">Pricing Rule Type</a> on page 2343

For more information on...	See...
<b>Pricing Rule Type List</b> zone	<a href="#">Pricing Rule Type List</a> on page 2344
<b>Pricing Rule Type</b> zone	<a href="#">Pricing Rule Type</a> on page 2347

## Viewing the Age Based Pricing Rule Type Details

### Procedure

To view the details of an age based pricing rule type:

1. Click the **Admin** link in the **Application** toolbar.  
A list appears.
2. From the **Admin** menu, select **P** and then click **Pricing Rule Type**.  
A sub-menu appears.
3. Click the **Search** option from the **Pricing Rule Type** sub-menu.  
The **Pricing Rule Type** screen appears.
4. In the **Pricing Rule Type List** zone, click the **Broadcast**  icon corresponding to the age based pricing rule type whose details you want to view.  
The **Pricing Rule Type** zone appears.
5. View the details of the age based pricing rule type in the **Pricing Rule Type** zone.

### Related Topics

For more information on...	See...
<b>Pricing Rule Type</b> screen	<a href="#">Pricing Rule Type</a> on page 2343
<b>Pricing Rule Type List</b> zone	<a href="#">Pricing Rule Type List</a> on page 2344
<b>Pricing Rule Type</b> zone	<a href="#">Pricing Rule Type</a> on page 2347

## Tier Based Pricing

The standard tier based pricing structure contains different tiers, such as Employee Only (E), Employee + Spouse (ES), Family (F), Employee + Children (EC). A main subscriber can subscribe his/her dependents to a policy plan and may fall in one of the tier. The fee for a price item can vary based on the membership tier level and employee attributes (such as employee type, employee status, etc.). Oracle Revenue Management and Billing enables you to offer a tier based pricing to a fully-insured customer. In the Tier Based pricing, the premium for the membership is derived based on tier level and employee attributes.

A tier based pricing can be defined using the tier based pricing rule. You can define a tier based pricing rule for a price item on the policy plan. If the tier based pricing rule is defined for a price item on a policy plan, all memberships which belong to the policy plan will inherit the tier based pricing from the policy plan. If the system does not find any effective pricing rule for a price item on the policy plan, it inherits the effective pricing rule for the price item from the parent customer level.

You can define a tier based pricing rule using a tier based pricing rule type. It is the tier based pricing rule type which helps the system to determine:

- Business object using which the tier based pricing rule should be created in the system.
- Algorithm which should be triggered for deriving the bill group, parent customer, and policy for a membership.

**Note:** You must create an algorithm using the **C1\_MEMBDRV** algorithm type and attach it to the **Bill Group Derivation** system event.

- Algorithm which should be triggered for deriving the account and price item for a membership.

**Note:** You must create an algorithm using the **C1\_ACCPRIMEM** algorithm type and attach it to the **Account and Price Item Derivation** system event.

- Algorithm which should be triggered for calculating the premium for membership.

**Note:** You must create an algorithm using the **C1\_TIERPREM** algorithm type and attach it to the **Pricing Rule Premium Calculation** system event.

- Algorithm which should be triggered for deriving the bill period for the account.

**Note:** You must create an algorithm using the **C1-FIBCBP** algorithm type and attach it to the **Pricing Rule BC Creation Pre Processing** system event.

- Algorithm which should be triggered for creating the SQI based billable charges for each membership and price item combination.

**Note:** You must create an algorithm using the **C1-FICRETBC** algorithm type and attach it to the **Pricing Rule Billable Charge Creation** system event.

- Price items for which you can define tier based pricing rules using the tier based pricing rule type.
- Rate options that you can use while defining the pricing for the respective price item.
- Type of account to which the respective price item should be billed based on the specified priority.
- Rule type which indicates the rules that should be executed to determine whether the price item is eligible for billing.
- Audit event types of the C1-Membership business object using which the audit event should be created whenever a membership is added, updated, or removed from the policy plan.
- Elements of the C1-Membership business object for which audit event should be created.

**Note:** You must ensure that either the **Update All** option is selected or the elements listed in the tier based pricing rule type are already present in the respective audit event type. Otherwise, erroneous results might occur.

Once a tier based pricing rule type is defined, you can define tier based pricing rules using the tier based pricing rule type. Note that, at present, you can define tier based pricing rules only through a healthcare inbound message and not from the user interface. However, you can view the tier based pricing rules defined for a policy plan from the **Customer 360° Information** screen. While creating a tier based pricing rule through a healthcare inbound message, you need to specify the following information:

- Entity type (i.e. Policy Plan) and entity ID (i.e. policy plan ID) for which you want to define the tier based pricing rule
- Start and end dates of the tier based pricing rule
- Tier based pricing rule type using which you want to create the tier based pricing rule
- Price Item for which you want to define tier based pricing
- Rate option using which the price assignment should be created for the tier based pricing rule

**Note:** If the rate option is not given in the pricing rule data, by default, it is set to a value specified in the **Default Rate Option – Flat** option type of the **C1-ASOBLNG** feature configuration when the modifier method is set to **FLAT** or **NULL**.

- Tier level and employee attributes for which the fee is applicable

**Note:** The tier level and employee attributes can be defined as the parameters in the system. These parameters can then be used to define eligibility criteria in the tier based pricing. Here, you can use only those parameters where the parameter usage is set to **Pricing Eligibility**.

Once the tier based pricing rule is defined for a policy plan, the system creates a price item pricing and price list and then assigns the price item pricing to the price list.

## Defining a Tier Based Pricing Rule Type

### Prerequisites

To define a tier based pricing rule type, you should have:

- Tier based pricing rule type business object defined in the application.
- Tier based pricing rule business object defined in the application.

### Procedure

To define a tier based pricing rule type pricing rule type:

1. Click the **Admin** link in the **Application** toolbar.  
A list appears.
2. From the **Admin** menu, select **P** and then click **Pricing Rule Type**.  
A sub-menu appears.
3. Click the **Add** option from the **Pricing Rule Type** sub-menu.

The **Select Business Object** screen appears. It contains the following field:

Field Name	Field Description	Mandatory (Yes or No)
Pricing Rule Type Business Object	Used to indicate the business object using which you want to create a tier based pricing rule type.  <b>Note:</b> You can create a tier based pricing rule type using the <b>Tier Based Pricing Rule Type (C1-PricingRuleTierBased)</b> business object.	Yes

**Tip:** Alternatively, you can access this screen by clicking the **Add** button in the **Page Title** area of the **Pricing Rule Type** screen.

4. Select the **Fully Insured Tier Based Pricing Rule Type** option from the **Pricing Rule Type Business Object** list.
5. Click **OK**.

The **Fully Insured Tier Based Pricing Rule Type** screen appears. It contains the following sections:

- **Main** – Used to specify basic details about a tier based pricing rule type.
- **Algorithms** – Used to associate the algorithms with a tier based pricing rule type.
- **Price Items** – Used to add the price items for which you can define the tier pricing rules using the tier based pricing rule type.
- **Price Item Parameters** – Used to add the price item parameters based on which you want to define the price item pricing.
- **Characteristics** – Used to define the characteristics for a tier based pricing rule type.

- **Event Management** – Used to configure the audit in a tier based pricing rule type.

The **Main** section contains the following fields:

Field Name	Field Description	Mandatory (Yes or No)
Pricing Rule Type	Used to specify the tier based pricing rule type.	Yes
Description	Used to specify the description for the tier based pricing rule type.	Yes
Detailed Description	Used to specify additional information about the tier based pricing rule type.	No
Pricing Rule Business Object	Used to indicate the business object using which you want to create the tier based pricing rule type. The valid value is: <ul style="list-style-type: none"> <li>• Fully Insured Tier Based Pricing Rule</li> </ul>	Yes
Business Object	Indicates the business object using which you are defining the tier based pricing rule type.	Not applicable
Status	Used to indicate the status of an age based pricing rule type. The valid values are: <ul style="list-style-type: none"> <li>• Active</li> <li>• Inactive</li> </ul>	Yes
Pricing Rule Type Category	Used to indicate the category to which the pricing rule type belongs. The valid value is: <ul style="list-style-type: none"> <li>• Tier Based</li> </ul>	Yes

6. Enter the required details in the **Main** section.
7. Associate the following algorithms with the tier based pricing rule type:

System Event	Algorithm	Algorithm Type	Description
Bill Group Derivation	C1_MEMBGDRV	C1_MEMBGDRV	Bill Group Derivation for Membership
Account and Price Item Derivation	C1_ACCPRIMEM	C1_ACCPRIMEM	Account and PriceItem Derivation for Membership
Pricing Rule Premium Calculation	C1_TIERPREM	C1_TIERPREM	Tier Based Premium Calculation
Pricing Rule BC Creation Pre Processing	C1-FIBCBP	C1-FIBCBP	Fetch Bill Period of Billable Charge of Membership
Pricing Rule Billable Charge Creation	C1-FICRETBC	C1-FICRETBC	Fully Insured Charge creation for memberships

8. Add the required price items in the tier based pricing rule type.
9. Add the price item parameters in the tier based pricing rule type, if required.
10. Define characteristics for the tier based pricing rule type, if required.
11. Configure the audit in the tier based pricing rule type.
12. Click **Save**.

The tier based pricing rule type is defined.

### Related Topics

<b>For more information on...</b>	<b>See...</b>
How to associate algorithms with the tier based pricing rule type	<a href="#">Associating an Algorithm with a Tier Based Pricing Rule Type</a> on page 2808
How to add price items in the tier based pricing rule type	<a href="#">Adding a Price Item in a Tier Based Pricing Rule Type</a> on page 2810
How to add price item parameters in the tier based pricing rule type	<a href="#">Adding a Price Item Parameter in a Tier Based Pricing Rule Type</a> on page 2813
How to define characteristics for the tier based pricing rule type	<a href="#">Defining Characteristics for a Tier Based Pricing Rule Type</a> on page 2814
How to add elements for audit in the tier based pricing rule type	<a href="#">Adding Elements for Audit in a Tier Based Pricing Rule Type</a> on page 2815

## Associating an Algorithm with a Tier Based Pricing Rule Type

### Prerequisites

To associate an algorithm with a tier based pricing rule type, you should have:

- An algorithm defined using the **C1\_MEMBGDRV** algorithm type.
- An algorithm defined using the **C1\_ACCPRIMEM** algorithm type.
- An algorithm defined using the **C1\_TIERPREM** algorithm type.
- An algorithm defined using the **C1-FIBCBP** algorithm type.
- An algorithm defined using the **C1-FICRETBC** algorithm type.



### Procedure

To associate an algorithm with a tier based pricing rule type:

1. Ensure that the **Algorithms** section is expanded when you are defining or editing the tier based pricing rule type.

The **Algorithms** section contains the following columns in a grid:



Column Name	Column Description	Mandatory (Yes or No)
System Event	Used to indicate the system event when you want to invoke the algorithm. The valid values are: <ul style="list-style-type: none"> <li>• <b>Bill Group Derivation</b> - Used to derive the bill group, parent customer, and policy for a membership.</li> <li>• <b>Account and Price Item Derivation</b> - Used to derive the account and price item for a membership.</li> <li>• <b>Pricing Rule Premium Calculation</b> - Used to calculate the premium for membership.</li> <li>• <b>Pricing Rule BC Creation Pre Processing</b> - Used to derive the bill period for the account.</li> <li>• <b>Pricing Rule Billable Charge Creation</b> - Used to create the SQI based billable charges for each membership and price item combination.</li> </ul>	Yes  <b>Note:</b> This field is required when you are associating an algorithm with the tier based pricing rule type.
Sequence	Used to specify the order in which the algorithms for each system event must be executed.	Yes (Conditional)  <b>Note:</b> This field is required when you are associating an algorithm with the tier based pricing rule type.
Algorithm	Used to specify the algorithm.  <b>Note:</b> Once you select the system event, the <b>Search</b>  icon appears corresponding to the <b>Algorithm</b> field. On clicking the <b>Search</b>  icon, the <b>Algorithm Search</b> window appears.  On specifying the algorithm, the description of the algorithm appears corresponding to the <b>Algorithm</b> field.	Yes (Conditional)  <b>Note:</b> This field is required when you are associating an algorithm with the tier based pricing rule type.

2. Enter the following details in the **Algorithms** section:

System Event	Algorithm	Algorithm Type	Description
Bill Group Derivation	C1_MEMBGDRV	C1_MEMBGDRV	Bill Group Derivation for Membership
Account and Price Item Derivation	C1_ACCPRIMEM	C1_ACCPRIMEM	Account and PriceItem Derivation for Membership
Pricing Rule Premium Calculation	C1_AGEPREM	C1_AGEPREM	Age Based Premium Calculation
Pricing Rule BC Creation Pre Processing	C1-FIBCBP	C1-FIBCBP	Fetch Bill Period of Billable Charge of Membership
Pricing Rule Billable Charge Creation	C1-FICRETBC	C1-FICRETBC	Fully Insured Charge creation for Memberships

- If you want to associate more than one algorithm with the tier based pricing rule type, click the **Add** (+) icon and then repeat step 2.

**Note:** However, if you want to disassociate an algorithm from the tier based pricing rule type, click the **Delete** (🗑️) icon corresponding to the algorithm.

- Click **Save**.

The algorithms are associated with the tier based pricing rule type.

### **Related Topics**

For more information on...	See...
How to define a tier based pricing rule type	<a href="#">Defining a Tier Based Pricing Rule Type</a> on page 2806
How to edit a tier based pricing rule type	<a href="#">Editing a Tier Based Pricing Rule Type</a> on page 2816

## **Adding a Price Item in a Tier Based Pricing Rule Type**

### **Prerequisites**

To add a price item in a tier based pricing rule type, you should have:

- Price item defined in the application
- Rate option defined in the **Rate Option (C1-ExtLookRefTypeRateOpt)** extendable lookup
- Values defined for the **Invoice Type (C1INVTYP)** characteristic type
- The **C1INVTYP** characteristic type set in the **Invoice Type Characteristic Type** option type of the **C1-ASOBLNG** feature configuration
- Rule types defined in the application (where the rule type usage is set to **Price Item Eligibility**)



### **Procedure**





To add a price item in a tier based pricing rule type:

- Ensure that the **Price Items** section is expanded when you are defining or editing a tier based pricing rule type.

The **Price Items** section contains the following fields in a grid:

Field Name	Field Description	Mandatory (Yes or No)
Price Item	<p>Used to indicate the price item that you want to include in a tier based pricing rule type.</p> <p><b>Note:</b> The <b>Search</b> (🔍) icon appears corresponding to the <b>Price Item</b> field. On clicking the <b>Search</b> icon, the <b>Price Item Search</b> window appears. On specifying the price item, the description of the price item appears corresponding to the <b>Price Item</b> field.</p>	<p>Yes (Conditional)</p> <p><b>Note:</b> This field is required when you are adding a rate option and bill to account in a tier based pricing rule type.</p>

Field Name	Field Description	Mandatory (Yes or No)						
Rate Option	<p>Used to indicate one or more rate options which are valid for a price item.</p> <p>On clicking the <b>Add</b> () icon, the following field appears in a grid:</p> <table border="1" data-bbox="472 426 1187 653"> <thead> <tr> <th data-bbox="472 426 610 537">Field Name</th> <th data-bbox="610 426 1045 537">Field Description</th> <th data-bbox="1045 426 1187 537">Mandatory (Yes or No)</th> </tr> </thead> <tbody> <tr> <td data-bbox="472 537 610 653">Rate Option</td> <td data-bbox="610 537 1045 653">Used to indicate the rate option that you want to use while defining pricing for the price item.</td> <td data-bbox="1045 537 1187 653">Yes</td> </tr> </tbody> </table> <p><b>Note:</b></p> <p>If you want to define more than one rate option to the price item in a tier based pricing rule type, click the <b>Add</b> () icon.</p> <p>However, if you want to remove a price item from a tier based pricing rule type, click the <b>Delete</b> () icon corresponding to the <b>Rate Option</b> field.</p>	Field Name	Field Description	Mandatory (Yes or No)	Rate Option	Used to indicate the rate option that you want to use while defining pricing for the price item.	Yes	Not applicable
Field Name	Field Description	Mandatory (Yes or No)						
Rate Option	Used to indicate the rate option that you want to use while defining pricing for the price item.	Yes						

Field Name	Field Description	Mandatory (Yes or No)									
Bill To Account	<p>Used to indicate a order in which the account should be considered while deriving a transaction leg.</p> <p>On clicking the <b>Add</b> () icon, the following fields appear in a grid:</p> <table border="1"> <thead> <tr> <th>Field Name</th> <th>Field Description</th> <th>Mandatory (Yes or No)</th> </tr> </thead> <tbody> <tr> <td>Priority</td> <td>Used to specify the order in which the invoice type is considered for a price item.</td> <td>Yes</td> </tr> <tr> <td>Invoice Type</td> <td>Used to indicate the type which is considered for billing. For more information, refer to the <i>Bill Group's Account</i> on page 55 section.</td> <td>Yes</td> </tr> </tbody> </table> <div style="border: 1px solid black; padding: 5px; margin-top: 5px;"> <p><b>Note:</b> The <b>Search</b> () icon appears corresponding to the <b>Invoice Type</b> field. On clicking the <b>Search</b> icon, the <b>Invoice Type Search</b> window appears.</p> </div> <div style="border: 1px solid black; padding: 5px; margin-top: 5px;"> <p><b>Note:</b></p> <p>If you want to define more than one invoice type to the price item in a tier based pricing rule type, click the <b>Add</b> () icon.</p> <p>However, if you want to remove a invoice type from the price item in a tier based pricing rule type, click the <b>Delete</b> () icon corresponding to the <b>Priority</b> field.</p> </div>	Field Name	Field Description	Mandatory (Yes or No)	Priority	Used to specify the order in which the invoice type is considered for a price item.	Yes	Invoice Type	Used to indicate the type which is considered for billing. For more information, refer to the <i>Bill Group's Account</i> on page 55 section.	Yes	Not applicable
Field Name	Field Description	Mandatory (Yes or No)									
Priority	Used to specify the order in which the invoice type is considered for a price item.	Yes									
Invoice Type	Used to indicate the type which is considered for billing. For more information, refer to the <i>Bill Group's Account</i> on page 55 section.	Yes									
Eligibility Rule Type	Used to indicate the rule type (which indicates the rules) that should be executed to determine whether the price item is eligible for billing.	No									

2. Enter the required details in the **Price Items** section.
3. If you want to define more than one price item in a tier based pricing rule type, click the **Add** () icon and then repeat step 2.

**Note:** However, if you want to remove a price item from a tier based pricing rule type, click the **Delete** () icon corresponding to the **Price Item** field.

4. Click **Save**.

The price items are added for a tier based pricing rule type.

### Related Topics

For more information on...	See...
How to define a tier based pricing rule type	<a href="#">Defining an Age Based Pricing Rule Type</a> on page 2790
How to edit a tier based pricing rule type	<a href="#">Editing a Tier Based Pricing Rule Type</a> on page 2816

## Adding a Price Item Parameter in a Tier Based Pricing Rule Type

### Prerequisites

To add a price item parameter in a tier based pricing rule type, you should have:



- Parameter defined in the application where parameter usage is set to **Price Item**.
- Parameter associated with the price item.

### Procedure

To add a price item parameter in a tier based pricing rule type:

1. Ensure that the **Price Item Parameters** section is expanded when you are defining or editing a tier based pricing rule type.

The **Price Item Parameters** section contains the following fields in a grid:

Field Name	Field Description	Mandatory (Yes or No)
Price Item Parameter	<p>Used to specify the parameter which you can use while defining a tier based pricing for the price item.</p> <p><b>Note:</b></p> <p>The Search  icon appears corresponding to the <b>Price Item Parameter</b> field. On clicking the Search  icon corresponding to the <b>Price Item Parameter</b> field, the <b>Parameter Search</b> window appears.</p> <p>On specifying the parameter, the description of the price item parameter appears corresponding to the <b>Price Item Parameter</b> field.</p>	<p>Yes (Conditional)</p> <p><b>Note:</b> This field is required when you are adding a price item parameter in a tier based pricing rule type.</p>

2. Enter the required details in the **Price Item Parameters** section.
3. If you want to add more than one price item parameter in a tier based pricing rule type, click the **Add**  icon and then repeat step 2.

**Note:** However, if you want to remove a price item parameter from a tier based pricing rule type, click the **Delete**  icon corresponding to the price item parameter.

4. Click **Save**.

The price item parameter is added for a tier based pricing rule type.

### Related Topics

For more information on...	See...
How to define a tier based pricing rule type	<a href="#">Defining a Tier Based Pricing Rule Type</a> on page 2806

For more information on...	See...
How to edit a tier based pricing rule type	<a href="#">Editing a Tier Based Pricing Rule Type</a> on page 2816

## Defining Characteristics for a Tier Based Pricing Rule Type

### Prerequisites

To define characteristics for a tier based pricing rule type, you should have:

- Characteristic types defined in the application (where the characteristic entity is set to **Pricing Rule Type**)

### Procedure

To define characteristics for a tier based pricing rule type:

1. Ensure that the **Characteristics** section is expanded when you are defining or editing a tier based pricing rule type.

The **Characteristics** section contains the following columns in a grid:

Field Name	Field Description	Mandatory (Yes or No)
Characteristic Type	Used to indicate the characteristic type. <b>Note:</b> The list includes only those characteristic types where the characteristic entity is set to <b>Pricing Rule Type</b> .	Yes (Conditional) <b>Note:</b> This field is required when you are defining a characteristic for a tier based pricing rule type.
Characteristic Value	Used to specify the value for the characteristic type. <b>Note:</b> On specifying the value for a predefined characteristic type, the description of the characteristic value appears corresponding to the <b>Characteristic Value</b> field.	Yes (Conditional) <b>Note:</b> This field is required when you are defining a characteristic for a tier based pricing rule type.

2. Enter the required details in the **Characteristics** section.

**Note:** If you select a predefined characteristic type, the **Search**  icon appears corresponding to the **Characteristic Value** field. On clicking the **Search** icon, you can search for a predefined characteristic value.

3. If you want to define more than one characteristic for a tier based pricing rule type, click the **Add**  icon and then repeat step 2.

**Note:** However, if you want to remove a characteristic from a tier based pricing rule type, click the **Delete**  icon corresponding to the characteristic.

4. Click **Save**.

The characteristics are defined for a tier based pricing rule type.

### Related Topics

For more information on...	See...
How to define a tier based pricing rule type	<a href="#">Defining an Age Based Pricing Rule Type</a> on page 2790

<b>For more information on...</b>	<b>See...</b>
How to edit a tier based pricing rule type	<a href="#">Editing a Tier Based Pricing Rule Type</a> on page 2816

## Adding Elements for Audit in a Tier Based Pricing Rule Type

### Prerequisites

To add elements for audit in a tier based pricing rule type, you should have:





- Business Object **C1-AuditEventType** defined for the pricing rule type.
- Audit Event Type defined in the application.

### Procedure

To add elements for audit in a tier based pricing rule type:

1. Ensure that the **Event Management** section is expanded when you are defining or editing a tier based pricing rule type.

The **Event Management** section contains the following fields in a grid:

Field Name	Field Description	Mandatory (Yes or No)
Audit Event Type	Used to specify the audit event type which you can use while adding elements for audit in an age based pricing rule type.  <b>Note:</b> The <b>Search</b>  icon appears corresponding to the <b>Audit Event Type</b> field. On clicking the <b>Search</b>  icon corresponding to the <b>Audit Event Type</b> field, the <b>Audit Event Type Search</b> window appears.  On specifying the audit event type, the description of the audit event type appears corresponding to the <b>Audit Event Type</b> field.	Yes
Element Type	Used to indicate the type of audit element for a tier based pricing rule type. The valid values are: <ul style="list-style-type: none"> <li>• Business Object Status</li> <li>• Characteristic</li> <li>• Field</li> </ul>	Not applicable
Element Name	Used to specify the element name for a tier based pricing rule type.  <b>Note:</b> The <b>Search</b>  icon appears corresponding to the <b>Element Name</b> field. On clicking the <b>Search</b>  icon corresponding to the <b>Element Name</b> field, the <b>Audit Event Type Element Name Search</b> window appears.	Yes
Element Value	Used to specify the value for an element name.	Not applicable

2. Enter the required details in the **Price Item Parameters** section.

- If you want to add more than one price item parameter in a tier based pricing rule type, click the **Add** (+) icon and then repeat step 2.

**Note:** However, if you want to remove a price item parameter from a tier based pricing rule type, click the **Delete** (🗑️) icon corresponding to the price item parameter.

- Click **Save**.

The price item parameter is added for a tier based pricing rule type.

### **Related Topics**

<b>For more information on...</b>	<b>See...</b>
How to define a tier based pricing rule type	<a href="#">Defining a Tier Based Pricing Rule Type</a> on page 2806
How to edit a tier based pricing rule type	<a href="#">Editing a Tier Based Pricing Rule Type</a> on page 2816

## **Editing a Tier Based Pricing Rule Type**

### **Prerequisites**

To edit a tier based pricing rule type, you should have:

- Tier Based pricing rule type business object defined in the application.
- Tier Based pricing rule business object defined in the application.

### **Procedure**

To edit a tier based pricing rule type:

- Click the **Admin** link in the **Application** toolbar.  
A list appears.
- From the **Admin** menu, select **P** and then click **Pricing Rule Type**.  
A sub-menu appears.
- Click the **Search** option from the **Pricing Rule Type** sub-menu.  
The **Pricing Rule Type** screen appears.
- In the **Pricing Rule Type List** zone, click the **Edit** (✎) icon in the **Edit** column corresponding to the pricing rule type whose details you want to edit.

The **Fully Insured Tier Based Pricing Rule Type** screen appears. It contains the following sections:

- Main** – Used to specify basic details about a tier based pricing rule type.
- Algorithms** – Used to associate the algorithms with a tier based pricing rule type.
- Price Items** – Used to add the price items for which you can define the tier based pricing rules using the tier based pricing rule type.
- Price Item Parameters** – Used to add the price item parameters based on which you want to define the price item pricing.
- Characteristics** – Used to define characteristics for a tier based pricing rule type.
- Event Management** – Used to configure the audit in a tier based pricing rule type.

The **Main** section contains the following fields:



Field Name	Field Description	Mandatory (Yes or No)
Pricing Rule Type	Displays the tier based pricing rule type.	Not applicable
Description	Used to specify the description for a tier based pricing rule type.	Yes
Detailed Description	Used to specify additional information about a tier based pricing rule type.	No
Pricing Rule Business Object	Used to indicate the business object using which you want to create a tier based pricing rule type. The valid value is: <ul style="list-style-type: none"> <li>Fully Insured Tier Based Pricing Rule</li> </ul>	Yes
Business Object	Indicates the business object using which you are defining a tier based pricing rule type.	Not applicable
Status	Used to indicate the status of a tier based pricing rule type. The valid values are: <ul style="list-style-type: none"> <li>Active</li> <li>Inactive</li> </ul>	Yes
Pricing Rule Type Category	Indicates the pricing rule type category for a tier based pricing rule type. The valid values is: <ul style="list-style-type: none"> <li>Age Based</li> </ul>	No

**Tip:** Alternatively, you can edit the details of a tier based pricing rule type by clicking the **Edit** button in the **Pricing Rule Type** zone.

- Modify the details in the **Main** section.
- Associate the following algorithms with a tier based pricing rule type:

System Event	Algorithm	Algorithm Type	Description
Bill Group Derivation	C1_MEMBGDRV	C1_MEMBGDRV	Bill Group Derivation for Membership
Account and Price Item Derivation	C1_ACCPRIMEM	C1_ACCPRIMEM	Account and PriceItem Derivation for Membership
Pricing Rule Premium Calculation	C1_AGEPREM	C1_AGEPREM	Age Based Premium Calculation
Pricing Rule BC Creation Pre Processing	C1-FIBCBP	C1-FIBCBP	Fetch Bill Period of Billable Charge of Membership
Pricing Rule Billable Charge Creation	C1-FICRETBC	C1-FICRETBC	Fully Insured Charge creation for memberships

- Add, edit, or remove the required price items in a tier based pricing rule type.
- Add, edit, or remove the price item parameters in a tier based pricing rule type, if required.
- Add, edit, or remove characteristics for a tier based pricing rule type, if required.
- Add, edit, or remove the configuration details of the audit in a tier based pricing rule type.
- Click **Save**.

The changes made to the tier based pricing rule type are saved.

### Related Topics

For more information on...	See...
How to associate algorithms with a tier based pricing rule type	<a href="#">Associating an Algorithm with a Tier Based Pricing Rule Type</a> on page 2808
How to add price items in a tier based pricing rule type	<a href="#">Adding a Price Item in a Tier Based Pricing Rule Type</a> on page 2810
How to add price item parameters in a tier based pricing rule type	<a href="#">Adding a Price Item Parameter in a Tier Based Pricing Rule Type</a> on page 2813
How to define characteristics for a tier based pricing rule type	<a href="#">Defining Characteristics for a Tier Based Pricing Rule Type</a> on page 2814
How to add elements for audit in a tier based pricing rule type	<a href="#">Adding Elements for Audit in a Tier Based Pricing Rule Type</a> on page 2815

## Deleting a Tier Based Pricing Rule Type

### Procedure

To delete a tier based pricing rule type:

1. Click the **Admin** link in the **Application** toolbar.  
A list appears.
2. From the **Admin** menu, select **P** and then click **Pricing Rule Type**.  
A sub-menu appears.
3. Click the **Search** option from the **Pricing Rule Type** sub-menu.  
The **Pricing Rule Type** screen appears.
4. In the **Pricing Rule Type List** zone, click the **Delete** (🗑️) icon in the **Delete** column corresponding to the tier based pricing rule type that you want to delete.  
A message appears confirming whether you want to delete the tier based pricing rule type.

**Note:** You can delete a tier based pricing rule type only when it is not yet used in the system.

**Tip:** Alternatively, you can delete a tier based pricing rule type by clicking the **Delete** button in the **Pricing Rule Type** zone.

5. Click **OK**.  
The tier based pricing rule type is deleted.

### Related Topics

For more information on...	See...
<b>Pricing Rule Type</b> screen	<a href="#">Pricing Rule Type</a> on page 2343
<b>Pricing Rule Type List</b> zone	<a href="#">Pricing Rule Type List</a> on page 2344
<b>Pricing Rule Type</b> zone	<a href="#">Pricing Rule Type</a> on page 2347

## Viewing the Tier Based Pricing Rule Type Details

### Procedure

To view the details of a tier based pricing rule type:

1. Click the **Admin** link in the **Application** toolbar.  
A list appears.
2. From the **Admin** menu, select **P** and then click **Pricing Rule Type**.  
A sub-menu appears.
3. Click the **Search** option from the **Pricing Rule Type** sub-menu.  
The **Pricing Rule Type** screen appears.
4. In the **Pricing Rule Type List** zone, click the **Broadcast**  icon corresponding to the tier based pricing rule type whose details you want to view.  
The **Pricing Rule Type** zone appears.
5. View the details of the tier based pricing rule type in the **Pricing Rule Type** zone.

### Related Topics

For more information on...	See...
<b>Pricing Rule Type</b> screen	<a href="#">Pricing Rule Type</a> on page 2343
<b>Pricing Rule Type List</b> zone	<a href="#">Pricing Rule Type List</a> on page 2344
<b>Pricing Rule Type</b> zone	<a href="#">Pricing Rule Type</a> on page 2347

## Pass-Through Billable Charge

At times, the system might receive pre-calculated premium for the membership through a healthcare inbound message. If the price item, account identifier type, and account identifier are given in the billable charge information of a healthcare inbound message, the system directly creates an SQI based billable charge when you process the healthcare inbound message. The pre-calculated premium amount is stored as a pass through line in the SQI based billable charge. But, if only the price item is given in the billable charge information, the system checks whether the price item is included in any pricing rule type where the pricing rule type category is set to **Pass-Through Billable Charge**. If so, the system checks whether the pass-through billable charge pricing rule type is associated with the policy plan to which the membership belongs (for which the billable charge information is received). It is the pass-through billable charge pricing rule type which helps the system to determine:

- Algorithm which should be triggered for deriving the bill group, parent customer, and policy for a membership.

**Note:** You must create an algorithm using the **C1\_MEMBGDRV** algorithm type and attach it to the **Bill Group Derivation** system event.

- Algorithm which should be triggered for deriving the account and price item for a membership.

**Note:** You must create an algorithm using the **C1\_ACCPRIMEM** algorithm type and attach it to the **Account and Price Item Derivation** system event.

- Algorithm which should be triggered for deriving the bill period for the account.

**Note:**

You must create an algorithm using the **C1-FIBCBP** algorithm type and attach it to the **Pricing Rule BC Creation Pre Processing** system event.

If the bill period or frequency is given in the billable charge information of the healthcare inbound message, the system does not derive the bill period for the account.

- Algorithm which should be triggered for creating the SQI based billable charges for each membership and price item combination.

**Note:** You must create an algorithm using the **C1-FICRETBC** algorithm type and attach it to the **Pricing Rule Billable Charge Creation** system event.

- Price items for which you can create the SQI based billable charges using the pass-through billable charge pricing rule type.

**Note:** You can add multiple price items in a pass-through billable charge pricing rule type. But, you cannot add the same price item in multiple pass-through billable charge pricing rule types.

- Type of account to which the respective price item should be billed based on the specified priority.

## Defining a Pass-Through Billable Charge Pricing Rule Type

### Prerequisites

To define a pass-through billable charge pricing rule type, you should have:

- Pass-through billable charge pricing rule type business object defined in the application.
- Pass-through billable charge pricing rule business object defined in the application.

### Procedure

To define a pass-through billable charge pricing rule type:

1. Click the **Admin** link in the **Application** toolbar.  
A list appears.
2. From the **Admin** menu, select **P** and then click **Pricing Rule Type**.  
A sub-menu appears.
3. Click the **Add** option from the **Pricing Rule Type** sub-menu.

The **Select Business Object** screen appears. It contains the following field:

Field Name	Field Description	Mandatory (Yes or No)
Pricing Rule Type Business Object	Used to indicate the business object using which you want to create a pass-through billable charge pricing rule type.  <b>Note:</b> You can create a pass-through billable charge pricing rule type using the <b>Pass-Through Billable Charge Pricing Rule Type (C1-FIPassthroughBcRuleType)</b> business object.	Yes

**Tip:** Alternatively, you can access this screen by clicking the **Add** button in the **Page Title** area of the **Pricing Rule Type** screen.

4. Select the **Pass-Through Billable Charge Pricing Rule Type** option from the **Pricing Rule Type Business Object** list.
5. Click **OK**.

The **Pass-Through Billable Charge Pricing Rule Type** screen appears. It contains the following sections:

- **Main** – Used to specify basic details about the pass-through billable charge pricing rule type.
- **Algorithms** – Used to associate the algorithms with the pass-through billable charge pricing rule type.
- **Price Items** – Used to add the price items for which you can define the pass-through billable charge pricing rules using the age based pricing rule type.
- **Price Item Parameters** – Used to add the price item parameters based on which you want to define the price item pricing.
- **Characteristics** – Used to define the characteristics for the pass-through billable charge pricing rule type.

The **Main** section contains the following fields:

Field Name	Field Description	Mandatory (Yes or No)
Pricing Rule Type	Used to specify the pass-through billable charge pricing rule type.	Yes
Description	Used to specify the description for the pass-through billable charge pricing rule type.	Yes
Detailed Description	Used to specify additional information about the pass-through billable charge pricing rule type.	No
Pricing Rule Business Object	Used to indicate the business object using which you want to create the pass-through billable charge pricing rule type. The valid value is: <ul style="list-style-type: none"> <li>• Pass-Through Billable Charge Pricing Rule</li> </ul>	Yes
Business Object	Indicates the business object using which you are defining the pass-through billable charge pricing rule type.	Not applicable
Status	Used to indicate the status of the pass-through billable charge pricing rule type. The valid values are: <ul style="list-style-type: none"> <li>• Active</li> <li>• Inactive</li> </ul>	Yes
Pricing Rule Type Category	Used to indicate the category to which the pricing rule type belongs. The valid value is: <ul style="list-style-type: none"> <li>• Pass-Through Billable Charge</li> </ul>	Yes

6. Enter the required details in the **Main** section.
7. Associate the following algorithms with the pass-through billable charge pricing rule type:

System Event	Algorithm	Algorithm Type	Description
Bill Group Derivation	C1_MEMBGDR	C1_MEMBGDR	Bill Group Derivation for Membership
Account and Price Item Derivation	C1_ACCPRIME	C1_ACCPRIME	Account and Price Item Derivation for Membership

System Event	Algorithm	Algorithm Type	Description
Pricing Rule BC Creation Pre Processing	C1-FIBCBP	C1-FIBCBP	Fetch Bill Period of Billable Charge of Membership
Pricing Rule Billable Charge Creation	C1-FICRETBC	C1-FICRETBC	Fully Insured Charge creation for Memberships

8. Add the required price items in the pass-through billable charge pricing rule type.
9. Add the price item parameters in the pass-through billable charge pricing rule type, if required.
10. Define characteristics for the pass-through billable charge pricing rule type, if required.
11. Click **Save**.

The pass-through billable charge pricing rule type is defined.

### **Related Topics**

For more information on...	See...
How to associate algorithms with the pass-through billable charge pricing rule type	<a href="#">Associating an Algorithm with a Pass-Through Billable Charge Pricing Rule Type</a> on page 2822
How to add price items in the pass-through billable charge pricing rule type	<a href="#">Adding a Price Item in a Pass-Through Billable Charge Pricing Rule Type</a> on page 2824
How to add price item parameters in the pass-through billable charge pricing rule type	<a href="#">Adding a Price Item Parameter in a Pass-Through Billable Charge Pricing Rule Type</a> on page 2826
How to define characteristics for the pass-through billable charge pricing rule type	<a href="#">Defining a Pass-Through Billable Charge Pricing Rule Type</a> on page 2820

## **Associating an Algorithm with a Pass-Through Billable Charge Pricing Rule Type**

### **Prerequisites**

To associate an algorithm with a pass-through billable charge pricing rule type, you should have:



- An algorithm defined using the **C1\_MEMBGDRV** algorithm type.
- An algorithm defined using the **C1\_ACCPRIMEM** algorithm type.
- An algorithm defined using the **C1-FIBCBP** algorithm type.
- An algorithm defined using the **C1-FICRETBC** algorithm type.

### **Procedure**

To associate an algorithm with a pass-through billable charge pricing rule type:

1. Ensure that the **Algorithms** section is expanded when you are defining or editing the pass-through billable charge pricing rule type.

The **Algorithms** section contains the following columns in a grid:

Column Name	Column Description	Mandatory (Yes or No)
System Event	Used to indicate the system event when you want to invoke the algorithm. The valid values are: <ul style="list-style-type: none"> <li>• <b>Bill Group Derivation</b> - Used to derive the bill group, parent customer, and policy for a membership.</li> <li>• <b>Account and Price Item Derivation</b> - Used to derive the account and price item for a membership.</li> <li>• <b>Pricing Rule BC Creation Pre Processing</b> - Used to derive the bill period for the account.</li> <li>• <b>Pricing Rule Billable Charge Creation</b> - Used to derive the price items for which you can create the SQI based billable charges using the pass-through billable charge pricing rule type.</li> </ul>	Yes  <b>Note:</b> This field is required when you are associating an algorithm with a pass-through billable charge pricing rule type.
Sequence	Used to specify the order in which the algorithms for each system event must be executed.	Yes (Conditional)  <b>Note:</b> This field is required when you are associating an algorithm with a pass-through billable charge pricing rule type.
Algorithm	Used to specify the algorithm.  <b>Note:</b> Once you select the system event, the <b>Search</b>  icon appears corresponding to the <b>Algorithm</b> field. On clicking the <b>Search</b>  icon, the <b>Algorithm Search</b> window appears. On specifying the algorithm, the description of the algorithm appears corresponding to the <b>Algorithm</b> field.	Yes (Conditional)  <b>Note:</b> This field is required when you are associating an algorithm with a pass-through billable charge pricing rule type.

2. Enter the following details in the **Algorithms** section:

System Event	Algorithm	Algorithm Type	Description
Bill Group Derivation	C1_MEMBGDRV	C1_MEMBGDRV	Bill Group Derivation for Membership
Account and Price Item Derivation	C1_ACCPRIMEM	C1_ACCPRIMEM	Account and PriceItem Derivation for Membership
Pricing Rule BC Creation Pre Processing	C1-FIBCBP	C1-FIBCBP	Fetch Bill Period of Billable Charge of Membership
Pricing Rule Billable Charge Creation	C1-FICRETBC	C1-FICRETBC	Fully Insured Charge creation for Memberships

3. If you want to associate more than one algorithm with a pass-through billable charge pricing rule type, click the **Add**  icon and then repeat step 2.

**Note:** However, if you want to disassociate an algorithm from a pass-through billable charge pricing rule type, click the **Delete** () icon corresponding to the algorithm.

4. Click **Save**.

The algorithms are associated with a pass-through billable charge pricing rule type.

### **Related Topics**

<b>For more information on...</b>	<b>See...</b>
How to define pass-through billable charge pricing rule type	<a href="#">Defining a Pass-Through Billable Charge Pricing Rule Type</a> on page 2820
How to edit pass-through billable charge pricing rule type	<a href="#">Editing a Pass-Through Billable Charge Pricing Rule Type</a> on page 2828

## **Adding a Price Item in a Pass-Through Billable Charge Pricing Rule Type**

### **Prerequisites**

To add a price item in a pass-through billable charge pricing rule type, you should have:

- Price item defined in the application
- Rate option defined in the **Rate Option (C1-ExtLookRefTypeRateOpt)** extendable lookup
- Values defined for the **Invoice Type (C1INVTYP)** characteristic type
- The **C1INVTYP** characteristic type set in the **Invoice Type Characteristic Type** option type of the **C1-ASOBLNG** feature configuration
- Rule types defined in the application (where the rule type usage is set to **Price Item Eligibility**)

### **Procedure**







To add a price item in a pass-through billable charge pricing rule type:

1. Ensure that the **Price Items** section is expanded when you are defining or editing a pass-through billable charge pricing rule type.

The **Price Items** section contains the following fields in a grid:

<b>Field Name</b>	<b>Field Description</b>	<b>Mandatory (Yes or No)</b>
Price Item	<p>Used to indicate the price item that you want to include in a pass-through billable charge pricing rule type.</p> <p><b>Note:</b></p> <p>The <b>Search</b> () icon appears corresponding to the <b>Price Item</b> field. On clicking the <b>Search</b> icon, the <b>Price Item Search</b> window appears.</p> <p>On specifying the price item, the description of the price item appears corresponding to the <b>Price Item</b> field.</p>	<p>Yes (Conditional)</p> <p><b>Note:</b> This field is required when you are adding a rate option and bill to account in a pass-through billable charge pricing rule type.</p>



Field Name	Field Description	Mandatory (Yes or No)									
Rate Option	<p>Used to indicate one or more rate options which are valid for a price item.</p> <p>On clicking the <b>Add</b> () icon, the following field appears in a grid:</p> <table border="1"> <thead> <tr> <th>Field Name</th> <th>Field Description</th> <th>Mandatory (Yes or No)</th> </tr> </thead> <tbody> <tr> <td>Rate Option</td> <td>Used to indicate the rate option that you want to use while defining pricing for the price item.</td> <td>Yes</td> </tr> </tbody> </table> <p><b>Note:</b> If you want to define more than one rate option to the price item in a pass-through billable charge pricing rule type, click the <b>Add</b> () icon. However, if you want to remove a price item from a pass-through billable charge pricing rule type, click the <b>Delete</b> () icon corresponding to the <b>Rate Option</b> field.</p>	Field Name	Field Description	Mandatory (Yes or No)	Rate Option	Used to indicate the rate option that you want to use while defining pricing for the price item.	Yes	Not applicable			
Field Name	Field Description	Mandatory (Yes or No)									
Rate Option	Used to indicate the rate option that you want to use while defining pricing for the price item.	Yes									
Bill To Account	<p>Used to indicate a order in which the account should be considered while deriving a transaction leg.</p> <p>On clicking the <b>Add</b> () icon, the following fields appear in a grid:</p> <table border="1"> <thead> <tr> <th>Field Name</th> <th>Field Description</th> <th>Mandatory (Yes or No)</th> </tr> </thead> <tbody> <tr> <td>Priority</td> <td>Used to specify the order in which the invoice type is considered for a price item.</td> <td>Yes</td> </tr> <tr> <td>Invoice Type</td> <td>Used to indicate the type which is considered for billing. For more information, refer to the <a href="#">Bill Group's Account</a> on page 55 section.</td> <td>Yes</td> </tr> </tbody> </table> <p><b>Note:</b> The <b>Search</b> () icon appears corresponding to the <b>Invoice Type</b> field. On clicking the <b>Search</b> icon, the <b>Invoice Type Search</b> window appears.</p> <p><b>Note:</b> If you want to define more than one invoice type to the price item in a pass-through billable charge pricing rule type, click the <b>Add</b> () icon. However, if you want to remove a invoice type from the price item in a pass-through billable charge pricing rule type, click the <b>Delete</b> () icon corresponding to the <b>Priority</b> field.</p>	Field Name	Field Description	Mandatory (Yes or No)	Priority	Used to specify the order in which the invoice type is considered for a price item.	Yes	Invoice Type	Used to indicate the type which is considered for billing. For more information, refer to the <a href="#">Bill Group's Account</a> on page 55 section.	Yes	Not applicable
Field Name	Field Description	Mandatory (Yes or No)									
Priority	Used to specify the order in which the invoice type is considered for a price item.	Yes									
Invoice Type	Used to indicate the type which is considered for billing. For more information, refer to the <a href="#">Bill Group's Account</a> on page 55 section.	Yes									
Eligibility Rule Type	Used to indicate the rule type (which indicates the rules) that should be executed to determine whether the price item is eligible for billing.	No									

- Enter the required details in the **Price Items** section.

- If you want to define more than one price item in a pass-through billable charge pricing rule type, click the **Add (+)** icon and then repeat step 2.

**Note:** However, if you want to remove a price item from a pass-through billable charge pricing rule type, click the **Delete (🗑)** icon corresponding to the **Price Item** field.

- Click **Save**.

The price items are added for a pass-through billable charge pricing rule type.

### **Related Topics**

For more information on...	See...
How to define a pass-through billable charge pricing rule type	<a href="#">Defining a Pass-Through Billable Charge Pricing Rule Type</a> on page 2820
How to edit a pass-through billable charge pricing rule type	<a href="#">Editing a Pass-Through Billable Charge Pricing Rule Type</a> on page 2828

## **Adding a Price Item Parameter in a Pass-Through Billable Charge Pricing Rule Type**

### **Prerequisites**

To add a price item parameter in a pass-through billable charge pricing rule type, you should have:

- Parameter defined in the application where parameter usage is set to **Price Item**.
- Parameter associated with the price item.

### **Procedure**

To add a price item parameter in a pass-through billable charge pricing rule type:

- Ensure that the **Price Item Parameters** section is expanded when you are defining or editing a pass-through billable charge pricing rule type.

The **Price Item Parameters** section contains the following fields in a grid:

Field Name	Field Description	Mandatory (Yes or No)
Price Item Parameter	<p>Used to specify the parameter which you can use while defining a pass-through billable charge pricing for the price item.</p> <p><b>Note:</b></p> <p>The <b>Search (🔍)</b> icon appears corresponding to the <b>Price Item Parameter</b> field. On clicking the <b>Search (🔍)</b> icon corresponding to the <b>Price Item Parameter</b> field, the <b>Parameter Search</b> window appears.</p> <p>On specifying the parameter, the description of the price item parameter appears corresponding to the <b>Price Item Parameter</b> field.</p>	<p>Yes (Conditional)</p> <p><b>Note:</b> This field is required when you are adding a price item parameter in a pass-through billable charge pricing rule type.</p>

- Enter the required details in the **Price Item Parameters** section.
- If you want to add more than one price item parameter in a pass-through billable charge pricing rule type, click the **Add (+)** icon and then repeat step 2.

**Note:** However, if you want to remove a price item parameter from a pass-through billable charge pricing rule type, click the **Delete** () icon corresponding to the price item parameter.

4. Click **Save**.

The price item parameter is added for a pass-through billable charge pricing rule type.

### **Related Topics**

For more information on...	See...
How to define a pass-through billable charge pricing rule type	<a href="#">Defining a Pass-Through Billable Charge Pricing Rule Type</a> on page 2820
How to edit a pass-through billable charge pricing rule type	<a href="#">Editing a Pass-Through Billable Charge Pricing Rule Type</a> on page 2828

## **Defining Characteristics for a Pass-Through Billable Charge Pricing Rule Type**

### **Prerequisites**

To define characteristics for a pass-through billable charge pricing rule type, you should have:

- Characteristic types defined in the application (where the characteristic entity is set to **Pricing Rule Type**)

### **Procedure**

To define characteristics for a pass-through billable charge pricing rule type:

1. Ensure that the

**Characteristics** section is expanded when you are defining or editing a pass-through billable charge pricing rule type.

The **Characteristics** section contains the following columns in a grid:

Field Name	Field Description	Mandatory (Yes or No)
Characteristic Type	Used to indicate the characteristic type. <b>Note:</b> The list includes only those characteristic types where the characteristic entity is set to <b>Pricing Rule Type</b> .	Yes (Conditional) <b>Note:</b> This field is required when you are defining a characteristic for a pass-through billable charge pricing rule type.
Characteristic Value	Used to specify the value for the characteristic type. <b>Note:</b> If you select a predefined characteristic type, the <b>Search</b> (  ) icon appears corresponding to the <b>Characteristic Value</b> field. On clicking the <b>Search</b> icon, the <b>Predefined Characteristic Search</b> window appears. On specifying the value for a predefined characteristic type, the description of the characteristic value appears corresponding to the <b>Characteristic Value</b> field.	Yes (Conditional) <b>Note:</b> This field is required when you are defining a characteristic for a pass-through billable charge pricing rule type.

2. Enter the required details in the **Characteristics** section.

- If you want to define more than one characteristic for a pass-through billable charge pricing rule type, click the **Add** (+) icon and then repeat step 2.

**Note:** However, if you want to remove a characteristic from a pass-through billable charge pricing rule type, click the **Delete** (🗑️) icon corresponding to the characteristic.

- Click **Save**.

The characteristics are defined for a pass-through billable charge pricing rule type.

### **Related Topics**

<b>For more information on...</b>	<b>See...</b>
How to define a pass-through billable charge pricing rule type	<a href="#">Defining a Pass-Through Billable Charge Pricing Rule Type</a> on page 2820
How to edit a pass-through billable charge pricing rule type	<a href="#">Editing a Pass-Through Billable Charge Pricing Rule Type</a> on page 2828

## **Editing a Pass-Through Billable Charge Pricing Rule Type**

### **Prerequisites**

To edit a pass-through billable charge pricing rule type, you should have:

- Pass-Through Billable Charge pricing rule type business object defined in the application.
- Pass-Through Billable Charge pricing rule business object defined in the application.

### **Procedure**

To edit a pass-through Billable Charge pricing rule type:

- Click the **Admin** link in the **Application** toolbar.  
A list appears.
- From the **Admin** menu, select **P** and then click **Pricing Rule Type**.  
A sub-menu appears.
- Click the **Search** option from the **Pricing Rule Type** sub-menu.  
The **Pricing Rule Type** screen appears.
- In the **Pricing Rule Type List** zone, click the **Edit** (✎) icon in the **Edit** column corresponding to the pricing rule type whose details you want to edit.

The **Pass-Through Billable Charge Age Based Pricing Rule Type** screen appears. It contains the following sections:

- Main** – Used to specify basic details about a pass-through billable charge pricing rule type.
- Algorithms** – Used to associate the algorithms with a pass-through billable charge pricing rule type.
- Price Items** – Used to add the price items for which you can define the pass-through billable charge pricing rules using the pass-through billable charge pricing rule type.
- Price Item Parameters** – Used to add the price item parameters based on which you want to define the price item pricing.
- Characteristics** – Used to define characteristics for a pass-through billable charge pricing rule type.

The **Main** section contains the following fields:

Field Name	Field Description	Mandatory (Yes or No)
Pricing Rule Type	Displays the pass-through billable charge pricing rule type.	Not applicable
Description	Used to specify the description for a pass-through billable charge pricing rule type.	Yes
Detailed Description	Used to specify additional information about a pass-through billable charge pricing rule type.	No
Pricing Rule Business Object	Used to indicate the business object using which you want to create a pass-through billable charge pricing rule type. The valid value is: <ul style="list-style-type: none"> <li>Pass-Through Billable Charge</li> </ul>	Yes
Business Object	Indicates the business object using which you are defining a pass-through billable charge pricing rule type.	Not applicable
Status	Used to indicate the status of a pass-through billable charge pricing rule type. The valid values are: <ul style="list-style-type: none"> <li>Active</li> <li>Inactive</li> </ul>	Yes
Pricing Rule Type Category	Indicates the pricing rule type category for a pass-through billable charge pricing rule type. The valid value is: <ul style="list-style-type: none"> <li>Pass-Through Billable Charge</li> </ul> <div style="border: 1px solid black; padding: 2px; margin-top: 5px;"><b>Note:</b> It is a read-only field, and cannot be edited.</div>	No

**Tip:** Alternatively, you can edit the details of a pass-through billable charge pricing rule type by clicking the **Edit** button in the **Pricing Rule Type** zone.

5. Modify the details in the **Main** section.
6. Associate the following algorithms with the pass-through billable charge pricing rule type:

System Event	Algorithm	Algorithm Type	Description
Bill Group Derivation	C1_MEMBGDRV	C1_MEMBGDRV	Bill Group Derivation for Membership
Account and Price Item Derivation	C1_ACCPRIMEM	C1_ACCPRIMEM	Account and PriceItem Derivation for Membership
Pricing Rule BC Creation Pre Processing	C1-FIBCBP	C1-FIBCBP	Fetch Bill Period of Billable Charge of Membership
Pricing Rule Billable Charge Creation	C1-FICRETBC	C1-FICRETBC	Fully Insured Charge creation for Memberships

7. Add, edit, or remove the required price items in a pass-through billable charge pricing rule type.
8. Add, edit, or remove the price item parameters in a pass-through billable charge pricing rule type, if required.
9. Add, edit, or remove characteristics for a pass-through billable charge pricing rule type, if required.
10. Click **Save**.

The changes made to the a pass-through billable charge pricing rule type are saved.

**Related Topics**

For more information on...	See...
How to associate algorithms with a pass-through billable charge pricing rule type	<a href="#">Associating an Algorithm with a Pass-Through Billable Charge Pricing Rule Type</a> on page 2822
How to add price items in a pass-through billable charge pricing rule type	<a href="#">Adding a Price Item in a Pass-Through Billable Charge Pricing Rule Type</a> on page 2824
How to add price item parameters in a pass-through billable charge pricing rule type	<a href="#">Adding a Price Item Parameter in a Pass-Through Billable Charge Pricing Rule Type</a> on page 2826
How to define characteristics for a pass-through billable charge pricing rule type	<a href="#">Defining Characteristics for a Pass-Through Billable Charge Pricing Rule Type</a> on page 2827

**Deleting a Pass-Through Billable Charge Pricing Rule Type****Procedure**

To delete a pass-through billable charge pricing rule type:

1. Click the **Admin** link in the **Application** toolbar.

A list appears.

2. From the **Admin** menu, select **P** and then click **Pricing Rule Type**.

A sub-menu appears.

3. Click the **Search** option from the **Pricing Rule Type** sub-menu.

The **Pricing Rule Type** screen appears.

4. In the **Pricing Rule Type List** zone, click the **Delete** (🗑️) icon in the **Delete** column corresponding to the pass-through billable charge pricing rule type that you want to delete.

A message appears confirming whether you want to delete the pass-through billable charge pricing rule type.

**Note:** You can delete a pass-through billable charge pricing rule type only when it is not yet used in the system.

**Tip:** Alternatively, you can delete a pass-through billable charge pricing rule type by clicking the **Delete** button in the **Pricing Rule Type** zone.

5. Click **OK**.

The pass-through billable charge pricing rule type is deleted.

**Related Topics**

For more information on...	See...
<b>Pricing Rule Type</b> screen	<a href="#">Pricing Rule Type</a> on page 2343
<b>Pricing Rule Type List</b> zone	<a href="#">Pricing Rule Type List</a> on page 2344
<b>Pricing Rule Type</b> zone	<a href="#">Pricing Rule Type</a> on page 2347

**Viewing the Pass-Through Billable Charge Pricing Rule Type Details****Procedure**

To view the details of a pass-through billable charge pricing rule type:

1. Click the **Admin** link in the **Application** toolbar.  
A list appears.
2. From the **Admin** menu, select **P** and then click **Pricing Rule Type**.  
A sub-menu appears.
3. Click the **Search** option from the **Pricing Rule Type** sub-menu.  
The **Pricing Rule Type** screen appears.
4. In the **Pricing Rule Type List** zone, click the **Broadcast**  icon corresponding to the pass-through billable charge pricing rule type whose details you want to view.  
The **Pricing Rule Type** zone appears.
5. View the details of the pass-through billable charge pricing rule type in the **Pricing Rule Type** zone.

#### **Related Topics**

<b>For more information on...</b>	<b>See...</b>
<b>Pricing Rule Type</b> screen	<a href="#">Pricing Rule Type</a> on page 2343
<b>Pricing Rule Type List</b> zone	<a href="#">Pricing Rule Type List</a> on page 2344
<b>Pricing Rule Type</b> zone	<a href="#">Pricing Rule Type</a> on page 2347





---

# Chapter 35

---

## Fully-Insured Billing

---

### Topics:

- *Audit Framework for Fully-Insured Health Care Billing*
- *Bill Group Derivation for Membership*
- *Account and Price Item Derivation for Membership*
- *State of Issue*
- *Membership Premium Calculation*
- *Repricing*
- *Fully Insured Billable Charge Creation*

This chapter explains how the billing is done for fully-insured health care business in Oracle Revenue Management and Billing. It contains the following topics:

- Audit Framework for Fully-Insured Health Care Billing
- Bill Group Derivation for Membership
- Account and Price Item Derivation for Membership
- State of Issue
- Membership Premium Calculation
- Repricing
- Fully Insured Billable Charge Creation

## Audit Framework for Fully-Insured Health Care Billing

Oracle Revenue Management and Billing calculates the membership premium when you add a membership to a policy plan. It also enables you to recalculate the membership premium in the following scenarios:

- A member person is added or removed from the membership.
- The fields, characteristics, or statuses which are monitored for the auditing purposes are updated at the membership, member person, or pricing rule level.
- A pricing rule is added or updated for the policy plan.

The membership premium calculation and recalculation (i.e. repricing) is implemented using the **Entity Audit** feature. The entity audit framework is already configured for the following business objects:

- C1-Membership
- C1\_PERSON\_BO
- C1-PricingRuleTierBased
- C1-PricingRuleAgeBased

But, the entity audit framework will work only when you define an active audit event type for the above listed business objects. Apart from configuring the entity audit framework and creating an active audit event type for the following business objects, you need to do the following:

Business Object	You need to...
C1-PricingRuleTierBased	Attach an algorithm created using the <b>C1-AUDEVMPR</b> algorithm type to the <b>Audit Event Processing</b> system event of the respective audit event type.
C1-PricingRuleAgeBased	Attach an algorithm created using the <b>C1-AUDEVMPR</b> algorithm type to the <b>Audit Event Processing</b> system event of the respective audit event type.
C1-Membership	Do not attach an algorithm created using the <b>C1-REAUDEVNT</b> algorithm type to the <b>Audit</b> system event of the <b>C1-Membership</b> business object.  <b>Note:</b> An algorithm created using the <b>C1-FIAUDEV</b> algorithm type is already attached to the <b>Audit</b> system event of the <b>C1-Membership</b> business object.
C1_PERSON_BO	Do not attach an algorithm created using the <b>C1-REAUDEVNT</b> algorithm type to the <b>Audit</b> system event of the <b>C1_PERSON_BO</b> business object.  <b>Note:</b> An algorithm created using the <b>C1-FIAUDEV</b> algorithm type is already attached to the <b>Audit</b> system event of the <b>C1_PERSON_BO</b> business object.

In addition, you need to list the following in the pricing rule types where the category is set to **Age Based** and **Tier Based**:

- Audit event types of the **C1-Membership** and **C1\_PERSON\_BO** business objects using which the audit event should be created whenever a membership and member person is added, updated, or removed from the policy plan, respectively.
- Elements of the **C1-Membership** and **C1\_PERSON\_BO** business objects for which auditing is required.

**Note:**

At present, you cannot use an audit event type of the **C1-Membership** and **C1\_PERSON\_BO** business objects in the **Age Based** and **Tier Based** pricing rule types when the **Update All** option is selected in the audit event type. Therefore, we recommend you to select an audit event type of the **C1-Membership** and **C1\_PERSON\_BO** business objects where the **Update All** option is not selected.

The system creates an audit event whenever the membership start and end dates and member person's start and end dates are changed in the system irrespective of whether these fields are listed for auditing or not in the age based or tier based pricing rule types.

You can also configure the entity audit feature for any custom membership or person business objects.

The way in which the audit events are created and processed for a pricing rule, membership, and member person is different. To view how the audit events are created and processed for an age based or tier based pricing rule, refer to [Age Based and Tier Based Pricing Rules Audit Process](#) on page 2835. To view how the audit events are created and processed for a membership, refer to [Membership Audit Process](#) on page 2836. However, to view how the audit events are created and processed for a person, refer to [Person Audit Process](#) on page 2839.

## Age Based and Tier Based Pricing Rules Audit Process

If you add, edit, or delete an age based or tier based pricing rule, the system checks whether an active audit event type exists for the **C1-PricingRuleAgeBased** or **C1-PricingRuleTierBased** business object, respectively. If so, it creates an audit event for the pricing rule using the audit event type. The audit event is created in the **Pending** status. Note that the system creates one audit event for the pricing rule irrespective of the number of changes made to the pricing rule. In addition, an effective date is stamped corresponding to the audit event which later helps in deriving the timeline during premium calculation. Note that the effective date is set to the pricing rule's start date.

On executing the **Audit Event Process Monitor (C1-AUDEV)** batch, the system considers the audit events in the **Pending** or **Error** status. By default, it considers the audit events in the **Pending** status. The system checks whether the **C1-AUDEVMPR** algorithm is attached to the respective audit event type. If the **C1-AUDEVMPR** algorithm is attached to the audit event type, it identifies the policy plan where the pricing rule is defined. Once the policy plan is identified, it extracts a list of membership defined on the policy plan and the pricing rule type using which the pricing rule is created. Then, the system creates a repricing entity detail record for each membership, pricing rule type, and effective date combination in the **CI\_REPRC\_ENTITY\_DTL** table. The status of the repricing entity detail record is set to **P**.

For example, an audit event is created while adding the following pricing rule:

<b>Audit Event</b>	AE1	AE2
<b>Pricing Rule</b>	AGBD	AFTG
<b>Pricing Rule Type Using which the Pricing Rule is Created</b>	PRT1	PRT3
<b>Pricing Rule Start Date</b>	01-01-2019	01-01-2019
<b>Policy Plan for which the Pricing Rule is Defined</b>	PP1	PP2
<b>Pricing Rule Types Associated with the Policy Plan</b>	PRT1, PRT2, PRT3	PRT3
<b>Memberships which Belong to the Policy Plan</b>	M1, M2, M3, and M4	M11 and M12

For the AE1 audit event, the system creates four repricing entity detail records with the following combinations in the **CI\_REPRC\_ENTITY\_DTL** table:

- M1, PRT1, 01-01-2019

- M2, PRT1, 01-01-2019
- M3, PRT1, 01-01-2019
- M4, PRT1, 01-01-2019

And, for the AE2 audit event, the system creates two repricing entity detail records with the following combinations in the **CI\_REPRC\_ENTITY\_DTL** table:

- M11, PRT3, 01-01-2019
- M12, PRT3, 01-01-2019

Once the repricing entity detail records are created successfully, the status of the audit event is set to **Complete**. However, if an error occurs while creating the repricing entity detail records for an audit event, the status of the audit event is set to **Error**.

## Membership Audit Process

If you add, edit, or delete a membership, the system checks whether an active audit event type exists for the **C1-Membership** business object. If so, it considers the active audit event type and creates the audit event using the respective audit event type. The system creates the audit event whenever a membership is added to a policy plan and member person is added to a membership. It also creates the audit event whenever the membership and member person details are updated. However, note that the audit events are created in the update scenario only when the element listed for auditing in the age based or tier based pricing rule types is updated. The system considers only those pricing rule types whose pricing rules are effective during the respective entity (i.e. membership or member person whichever is updated) date range.

The audit event is created in the **Pending** status. Note that the system creates distinct audit events in the following scenarios:

Scenario	System Behavior
A membership is added to the policy plan.	One audit event is created for the membership. Here, the effective date in the audit event is set to the membership's start date.
A member person is added to the membership.	One audit event is created for the membership. Here, the effective date in the audit event is set to the member person's start date.
A member person is removed from the membership.	One audit event is created for the membership. Here, the effective date in the audit event is set to the member person's start date.
Membership characteristics are added or updated in the system.	Multiple audit events are created for the membership – one for each set of membership characteristics with the same effective date. Here, the effective date in the audit event is set to the date from when the membership's characteristic is effective.
Member person characteristics are added or updated in the system.	Multiple audit events are created for the membership – one for each set of member person's characteristics with the same effective date. Here, the effective date in the audit event is set to the date from when the member person's characteristic is effective.
A set of membership fields except membership end date is updated in the system.	One audit event is created for the membership. Here, the effective date in the audit event is set to the membership's start date.
The membership end date is updated in the system.	One audit event is created for the membership. Here, the effective date in the audit event is set to membership's end date.
A set of member person's fields except member person start and end dates is updated in the system.	One audit event is created for the membership. Here, the effective date in the audit event is set to the member person's start date.

Scenario	System Behavior
<p>The member person's start date is updated in the system.</p>	<p>Three audit events are created for the membership – one where the effective date is set to the member person's previous start date, another where the effective date is set to the member person's new start date, and third where the effective date is set to member person's end date + 1 Day. However, if the derived effective date is later than the membership end date, the system does not create the third audit event for the membership. In such scenario, it simply creates first two audit events.</p> <p>For example, the Mike's effective date range is changed from 04-01-2019 – 09-30-2019 to 01-15-2019 – 09-30-2019 in the M1 membership which is effective from 01-01-2019 to 12-31-2019. In such case, the system will create three audit events – one with effective date as 04-01-2019, another with effective date as 01-15-2019, and third with effective date as 10-01-2019 (i.e. 09-30-2019 + 1 Day).</p> <p>In addition, if there is a characteristic for the person whose effective date falls with the new enrollment date range, the system creates an audit event for the person where the effective date is set to characteristic's effective date. Note that the system considers those effective characteristics where the characteristic entity is set to <b>Person</b>. Let us assume that in the above example a characteristic for Mike was effective from 02-01-2019. In such case, the system creates three audit events for membership (with the effective dates as mentioned above) and one audit event for the person (i.e. Mike) where the effective date is set to 02-01-2019.</p>
<p>The member person's end date is updated in the system.</p>	<p>Two audit events are created for the membership – one where the effective date is set to member person's previous end date + 1 Day and another where the effective date is set to member person's new end date + 1 Day. However, if the derived effective date is later than the membership end date, the system does not create the second audit event for the membership. In such scenario, it simply creates first audit event.</p> <p>For example, the Garry's effective date range is changed from 04-01-2019 – 09-30-2019 to 04-01-2019 – 12-31-2019 in the M1 membership which is effective from 01-01-2019 to 12-31-2019. In such case, the system will create one audit event with the effective date as 10-01-2019 (i.e. 09-30-2019 + 1 Day). It will not create another audit event because the derived effective date is later than membership end date.</p> <p>In addition, if there is a characteristic for the person whose effective date falls with the new enrollment date range, the system creates an audit event for the person where the effective date is set to characteristic's effective date. Note that the system considers those effective characteristics where the characteristic entity is set to <b>Person</b>. Let us assume that in the above example a characteristic for Garry was effective from 11-01-2019. In such case, the system creates one audit event for membership (with the effective date as mentioned above) and one audit event for the person (i.e. Garry) where the effective date is set to 11-01-2019.</p>

Scenario	System Behavior
<p>The member person's start and end dates are updated in the system.</p>	<p>Four audit events are created for the membership – one where the effective date is set to the member person's previous start date, another where the effective date is set to the member person's new start date, third where the effective date is set to member person's previous end date + 1 Day, and fourth where the effective date is set to member person's new end date + 1 Day. However, if the derived effective date is later than the membership end date, the system does not create the fourth audit event for the membership. In such scenario, it simply creates first three audit events.</p> <p>For example, the Juliet's effective date range is changed from 04-01-2019 – 09-30-2019 to 01-01-2019 – 11-30-2019 in the M1 membership which is effective from 01-01-2019 to 12-31-2019. In such case, the system will create four audit events – one with effective date as 04-01-2019, another with effective date as 01-01-2019, third with effective date as 10-01-2019 (i.e. 09-30-2019 + 1 Day), and fourth with effective date as 12-01-2019 (i.e. 11-30-2019 + 1 Day).</p> <p>In addition, if there is a characteristic for the person whose effective date falls with the new enrollment date range, the system creates an audit event for the person where the effective date is set to characteristic's effective date. Note that the system considers those effective characteristics where the characteristic entity is set to <b>Person</b>. Let us assume that in the above example two characteristics of Juliet were effective from 03-01-2019 and 10-01-2019, respectively. In such case, the system creates four audit events for membership (with the effective dates as mentioned above), fifth audit event for the person (i.e. Juliet) where the effective date is set to 03-01-2019, and sixth audit event for the person (i.e. Juliet) where the effective date is set to 10-01-2019.</p>

For each audit event, the system identifies the policy plan to which the membership belongs and the active pricing rules defined on the policy plan. It then identifies the pricing rule types using which these active pricing rules are created in the system. A repricing entity detail record is created for each membership, pricing rule type, and effective date combination in the **CI\_REPRC\_ENTITY\_DTL** table. The status of the repricing entity detail record is set to **P**.

For example, an audit event is created while adding the following memberships:

<b>Audit Event</b>	AE11	AE12
<b>Membership</b>	M1	M2
<b>Membership Start Date</b>	01-03-2019	01-02-2019
<b>Policy Plan to which Membership Belongs</b>	PP11	PP12
<b>Pricing Rules Defined on the Policy Plan</b>	PR1 (PRT1), PR2 (PRT2), PR3 (PRT3)	PR11 (PRT1), PR13 (PRT2)
<b>Pricing Rule Types Associated with the Policy Plan</b>	PRT1, PRT2, PRT3	PRT1, PRT2

For the AE11 audit event, the system creates three repricing entity detail records with the following combinations in the **CI\_REPRC\_ENTITY\_DTL** table:

- M1, PRT1, 01-03-2019
- M1, PRT2, 01-03-2019

- M1, PRT3, 01-03-2019

And, for the AE12 audit event, the system creates two repricing entity detail records with the following combinations in the **CI\_REPRC\_ENTITY\_DTL** table:

- M2, PRT1, 01-02-2019
- M2, PRT2, 01-02-2019

Once the repricing entity detail records are created successfully, the status of the audit event is set to **Complete**.

## Person Audit Process

If you add, edit, or delete a person, the system checks whether an active audit event type exists for the **C1\_PERSON\_BO** business object. If so, it creates an audit event for the person using the audit event type. The audit event is created in the **Pending** status. Note that the system creates distinct audit events in the following scenarios:

Scenario	System Behavior
Person characteristics are added or updated in the system.	Multiple audit events are created for the person – one for each set of person characteristics with the same effective date. Here, the effective date in the audit event is set to the date from when the person’s characteristic is effective.
Person fields are updated in the system.	One audit event is created for the person. Here, the effective date in the audit event is set to the member person’s start date.

For each audit event, the system identifies the memberships in which the person is added as a member person. It then identifies the policy plan to which each membership belongs and the active pricing rules defined on the policy plan. It then identifies the pricing rule types using which these active pricing rules are created in the system. A repricing entity detail record is created for each membership, pricing rule type, and effective date combination in the **CI\_REPRC\_ENTITY\_DTL** table. The status of the repricing entity detail record is set to **P**. For example, an audit event named AE1 is created while updating the P1 person:

Audit Event	AE1		
Membership to which P1 belongs	M1	M2	M3
Member Person’s Start Date	01-01-2019	01-01-2019	01-07-2019
Policy Plan to which Membership Belongs	PP1	PP2	PP3
Pricing Rules Defined on the Policy Plan	PR1 (PRT1), PR2 (PRT2)	PR3 (PRT3), PR4 (PRT3)	PR5 (PRT5), PR6 (PRT6)
Pricing Rule Types Associated with the Policy Plan	PRT1, PRT2	PRT3, PRT4	PRT5, PRT6

For the AE1 audit event, the system creates five repricing entity detail records with the following combinations in the **CI\_REPRC\_ENTITY\_DTL** table:

- M1, PRT1, 01-01-2019
- M1, PRT2, 01-01-2019
- M2, PRT3, 01-01-2019
- M3, PRT5, 01-07-2019
- M3, PRT6, 01-07-2019

Once the repricing entity detail records are created successfully, the status of the audit event is set to **Complete**.

**Note:**

If the audit event's effective date is earlier than the member person's start date, the system sets the effective date in the repricing entity detail record to the member person's start date. Therefore, in such scenarios, the effective date of the audit event and repricing entity detail records will be different.

While creating an audit event, the system checks whether an audit event for the entity with the same effective date exists in the **Pending** status. If so, the system does not create a new audit event for the entity. Instead, the system adds a log in the existing audit event.

## Bill Group Derivation for Membership

---

A new algorithm type named **C1\_MEMBGDRV** is added in this release. You need to attach an algorithm created using the **C1\_MEMBGDRV** algorithm type to the **Bill Group Derivation** system event in a pricing rule type where the category is set to **Age Based**, **Tier Based**, or **Pass-Through Billable Charge**.

This algorithm derives the policy from the policy plan to which the membership belongs. Once the policy is derived, the system derives the source system from the policy. The Bill Level 1, Bill Level 2, Bill Level 3, and Bill Level 4 characteristics defined on the membership indicate the Parameter 1, Parameter 2, Parameter 3, and Parameter 4. The system derives a bill group using the derivation and pricing parameters (i.e. Source System, Parameter 1, Parameter 2, Parameter 3, and Parameter 4) which are defined for the bill group. Note that the system considers the derivation and pricing parameters which are effective on the effective date (which is available corresponding to the record in the **CI\_REPRC\_ENTITY\_DTL** table). It first searches for the bill group using the exact match. If the exact match is not available, the system finds the bill group using the best fit match. Note that while searching for a bill group, the source system and Parameter 1 (i.e. Bill Level 1) are mandatory.

This algorithm contains the following parameters:

- **Characteristic Type for Bill Level 1** – Used to indicate the characteristic type. This characteristic type must be defined on the membership. It is used to store the derivation and pricing parameter 1 for the membership.
- **Characteristic Type for Bill Level 2** - Used to indicate the characteristic type. This characteristic type must be defined on the membership. It is used to store the derivation and pricing parameter 2 for the membership.
- **Characteristic Type for Bill Level 3** - Used to indicate the characteristic type. This characteristic type must be defined on the membership. It is used to store the derivation and pricing parameter 3 for the membership.
- **Characteristic Type for Bill Level 4** - Used to indicate the characteristic type. This characteristic type must be defined on the membership. It is used to store the derivation and pricing parameter 4 for the membership.

Once the bill group is derived, the system derives the parent customer of the bill group. If the system could not derive the policy, bill group, or parent customer, the status of the record is changed to **Error (E)** in the **CI\_REPRC\_ENTITY\_DTL** table.

## Account and Price Item Derivation for Membership

---

A new algorithm type named **C1\_ACCPRIMEM** is added in this release. You need to attach an algorithm created using the **C1\_ACCPRIMEM** algorithm type to the **Account and Price Item Derivation** system event in a pricing rule type where the category is set to **Age Based**, **Tier Based**, or **Pass-Through Billable Charge**.

This algorithm fetches the effective pricing rule for each price item specified in the pricing rule type on the effective date. It first searches for effective pricing rules on the policy plan to which the membership belongs. If the system does not find any effective pricing rule for a price item on the policy plan, it inherits the effective pricing rule for the price item from the parent customer level. The system then derives the account with a particular invoice type (to which a price item must be billed) based on the priority which is defined for the respective price item in the pricing rule type. Once the account is derived, the system then checks whether the account has one active contract of the contract type which is associated with the price item. If so, it fetches the contract for further processing. If the system could not derive the



effective pricing rule for any price item or if the account or active contract for the account could not be derived, the status of the record is changed to **Error (E)** in the CI\_REPRC\_ENTITY\_DTL table.

## State of Issue

---

The State of Issue feature enables you to search for the following characteristics on a state:

- Maximum Number of Dependents
- Maximum Age Limit for Maximum Dependent Count
- Maximum Number of Dependents Order Priority
- Age Calculation Date Basis
- Newborn Gift Days
- Newborn Gift Days Applicability
- Young Adult Max Age Limit
- Young Adult Inclusion Applicability

It helps in identifying a list of eligible children in a membership. To enable the State of Issue feature, you need to do the following:

1. Define a predefined characteristic type named **State of Issue** where the characteristic entity is set to **Membership, Policy Plan** and **Policy**.
2. Define the required states as the predefined values for the **State of Issue** characteristic type.
3. Set the **State of Issue** characteristic type in the **State of Issue Characteristic Type** option type of the **C1-ASOBLLNG** feature configuration.

If the State of Issue feature is enabled, the system checks whether the **State of Issue** characteristic is defined for the membership when any of the above required characteristic is not defined at the membership person and membership levels. If the **State of Issue** characteristic is defined for the membership, the system checks whether the above required characteristic is defined on the state where the membership is issued. For example, if the **State of Issue** characteristic on the M1 membership is set to **California**, then the system will search for any of the above required characteristic on the **California** state. If the required characteristic is defined for the state, the system considers it while identifying a list of eligible children in the membership.

If the required characteristic is not defined at the membership person, membership, state where the membership is issued and policy plan levels, the system checks whether the **State of Issue** characteristic is defined for the policy plan. If the **State of Issue** characteristic is defined for the policy plan, the system checks whether the above required characteristic is defined on the state where the policy plan is issued. If the required characteristic is defined for the state, the system considers it while identifying a list of eligible children in the membership.

However, if the required characteristic is not defined at the membership person, membership, state where membership is issued, policy plan, state where the policy plan is issued, and policy levels, the system checks whether the **State of Issue** characteristic is defined for the policy. If the **State of Issue** characteristic is defined for the policy, the system checks whether the above required characteristic is defined on the state where the policy is issued. If the required characteristic is defined for the state, the system considers it while identifying a list of eligible children in the membership.

## Membership Premium Calculation

---

The membership premium is calculated differently using the following pricing:

- **Age-Based Pricing** – The system first identifies a list of members which are eligible for premium calculation in a membership. It derives the main subscriber and member persons (i.e. Spouse and Children) which are related to the main subscriber using the relationship type specified in the **Age Based** pricing rule type. To identify a list of eligible children for premium calculation, the system uses the following characteristics:

- **Maximum Number of Dependents** – Used to indicate the maximum number of children which are eligible for premium calculation.
- **Maximum Age Limit for Maximum Dependent Count** – Used to indicate the maximum age limit for children which are eligible for premium calculation.
- **Maximum Number of Dependents Order Priority** – Used to indicate whether you want to consider the youngest or eldest children during premium calculation. The valid values are - **YOUNGEST** and **ELDEST**.
- **Age Calculation Date Basis** – Used to indicate whether the member person’s age should be calculated using the member person’s enrollment date or policy’s start or renewal date.
- **Newborn Gift Days** – Used to indicate the number of days you want to offer as gift days from the new born child’s birth date. As a result, no premium will be calculated for this period.
- **Newborn Gift Days Applicability** – Used to indicate whether you want to offer gift days in case of a new born. The valid values are - **Y** and **N**.
- **Young Adult Max Age Limit** – Used to indicate the maximum age limit for young adults which are eligible for premium calculation.
- **Young Adult Inclusion Applicability** – Used to indicate whether you want to consider the young adults during the premium calculation. The valid values are - **Y** and **N**.

**Note:** Only the **Age Calculation Date Basis (C1-AGCAL)** characteristic type is shipped with the product. You need to create the remaining characteristic types in the system and set their characteristic entity to the following - **Membership Person, Membership, Policy Plan, Policy,** and/or **State**.

The system searches for these characteristics on the following entities in the specified sequence:

1. Membership Person
2. Membership
3. State where the Membership is issued
4. Policy Plan
5. State where the Policy Plan is Issued
6. Policy
7. State where the Policy is Issued

For example, if the **Maximum Number of Dependents** characteristic is defined for all entities, the system considers the characteristic which is defined at the Member Person level because it is the lowest level. However, if the **Newborn Gift Days Applicability** characteristic is defined at the Policy Plan and Policy levels, the system considers the characteristic which is defined at the Policy Plan level because it is the lowest level. In other words, the system crawls from the lowest to the highest level while searching for the above characteristics. You can also define the above characteristics on the state where the membership, policy plan and/or policy are issued. For more information, refer to the State of Issue section.

Once the eligible members for premium are identified, the system derives the base fee and applicable modifier fee which are defined in the pricing rules. The system then calculates the timeline for each membership and price item combination. The timeline is basically calculated to understand the period for which the premium is applicable. For example, if a policy plan named **P1** has the following membership:

<b>Membership</b>	M1
<b>Member Persons</b>	P1 and P2
<b>Membership Start Date</b>	01-01-2019

<b>Membership End Date</b>	31-12-2019
<b>P0 Main Subscriber's Start Date</b>	01-01-2019
<b>P0 Main Subscriber's End Date</b>	31-12-2019
<b>P1 Member's Start Date</b>	01-01-2019
<b>P1 Member's End Date</b>	30-06-2019
<b>P2 Member's Start Date</b>	01-10-2019
<b>P2 Member's End Date</b>	31-12-2019

The **P1** policy plan is associated with an Age Based pricing rule type which contains the **Premium Fee** price item. The Age Based pricing rule for the **Premium Fee** price item is effective from 01-01-2019 to 31-12-2019.

In this case, the system will create the following timelines when you add **P2** member person in the **M1** membership:

<b>Membership</b>	<b>Price Item</b>	<b>Timeline Start Date (Effective Date)</b>	<b>Timeline End Date</b>
M1	Premium Fee	01-01-2019	30-06-2019 (i.e. P1 Member's End Date)
M1	Premium Fee	01-07-2019	30-09-2019
M1	Premium Fee	01-10-2019 (i.e. P2 Member's Start Date)	31-12-2019

It creates timelines using the membership's start and end dates, member person's start and end dates, and effective date. For each timeline, the system calculates the premium for all eligible member persons in the membership. Let us assume that the effective pricing rule is configured in the following manner:

<b>Age Band</b>	<b>Fee</b>
0-21	\$50
21-65	\$100
>65	\$150

P0 belongs to the 21-65 age band and P1 and P2 belongs to the 0-21 age band. Therefore, the premium is calculated using the following base fee:

<b>Membership</b>	<b>Price Item</b>	<b>Timeline Start Date (Effective Date)</b>	<b>Timeline End Date</b>	<b>Base Fee</b>
M1	Premium Fee	01-01-2019	30-06-2019 (i.e. P1 Member's End Date)	P0: \$100 P1: \$50
M1	Premium Fee	01-07-2019	30-09-2019	P0: \$100
M1	Premium Fee	01-10-2019 (i.e. P2 Member's Start Date)	31-12-2019	P0: \$100 P2: \$50

Now, let us assume the following characteristics are defined on the **P1** policy plan which offers gift days to a new born child:

Effective Date	Characteristic Type	Characteristic Value
01-01-2019	Newborn Gift Days Applicability	Y
01-01-2019	Newborn Gift Days	30

Now, if the main subscriber adds his child named **C1** who is born on 05-03-2019, the system will create the following timelines:

Membership	Price Item	Timeline Start Date (Effective Date)	Timeline End Date
M1	Premium Fee	01-01-2019	03-04-2019 (i.e. 05-03-2019 +30 Days)
M1	Premium Fee	04-04-2019 (New Born Considered for Premium Calculation)	30-06-2019 (i.e. P1 Member's End Date)
M1	Premium Fee	01-07-2019	30-09-2019
M1	Premium Fee	01-10-2019 (i.e. P2 Member's Start Date)	31-12-2019

It creates timelines using the membership's start and end dates, member person's start and end dates, and effective date. For each timeline, the system calculates the premium for all eligible member persons in the membership. In this case, the premium is calculated using the following base fee:

Membership	Price Item	Timeline Start Date (Effective Date)	Timeline End Date	Base Fee
M1	Premium Fee	01-01-2019	03-04-2019 (i.e. 05-03-2019 +30 Days)	P0: \$100 P1: \$50
M1	Premium Fee	04-04-2019 (New Born Considered for Premium Calculation)	30-06-2019 (i.e. P1 Member's End Date)	P0: \$100 P1: \$50 C1: \$50
M1	Premium Fee	01-07-2019	30-09-2019	P0: \$100 C1: \$50
M1	Premium Fee	01-10-2019 (i.e. P2 Member's Start Date)	31-12-2019	P0: \$100 P2: \$50 C1: \$50

- Tier Based Pricing** – The system first derives the base fee which is defined in the pricing rules. It then calculates the timeline for each membership and price item combination. The timeline is basically calculated to understand the period for which the premium is applicable. For example, if a policy plan named **P2** has the following membership:

<b>Membership</b>	M1
<b>Member Persons</b>	P1 and P2

<b>Membership Start Date</b>	01-01-2019
<b>Membership End Date</b>	31-12-2019
<b>Membership Tier</b>	ES (Employee + Spouse)

The **P2** policy plan is associated with a Tier Based pricing rule type which contains the **Premium Fee** price item. The Tier Based pricing rule for the **Premium Fee** price item is effective from 01-01-2019 to 31-12-2019.

The system will create the following timeline when the **M1** membership is added to the **P2** policy plan:

<b>Membership</b>	<b>Price Item</b>	<b>Timeline Start Date (Effective date)</b>	<b>Timeline End Date</b>
M1	Premium Fee	01-01-2019	31-12-2019

It creates timelines using the membership's start and end dates and effective date. For each timeline, the system calculates premium for the membership. Let us assume that the effective pricing rule is configured in the following manner:

<b>Tier Level</b>	<b>Fee</b>
E (Employee Only)	\$100
ES (Employee + Spouse)	\$200
F (Family)	\$350
EC (Employee+ Children)	\$150

The **M1** membership belongs to the **ES (Employee + Spouse)** tier. Therefore, the premium is calculated using the following base fee:

<b>Membership</b>	<b>Price Item</b>	<b>Timeline Start Date (Effective Date)</b>	<b>Timeline End Date</b>	<b>Base Fee</b>
M1	Premium Fee	01-01-2019	31-12-2019	\$200

Now, let us assume the following characteristics are defined on the **P2** policy plan which offers gift days to a new born child:

<b>Effective date</b>	<b>Characteristic Type</b>	<b>Characteristic value</b>
01-01-2019	Newborn Gift Days Applicability	Y
01-01-2019	Newborn Gift Days	30

Now, if the main subscriber adds his child named **C1** who is born on 05-03-2019, the system will create the following timelines:

<b>Membership</b>	<b>Price Item</b>	<b>Timeline Start Date (Effective date)</b>	<b>Timeline End Date</b>
M1	Premium Fee	01-01-2019	03-04-2019 (i.e. 05-03-2019 +30 Days)
M1	Premium Fee	04-04-2019 (New Born Considered for Premium Calculation)	31-12-2019

In this case, the premium is calculated using the following base fee considering the membership tier has changed from **ES (Employee + Spouse)** to **F (Family)**:

Membership	Price Item	Timeline Start Date (Effective Date)	Timeline End Date	Base Fee
M1	Premium Fee	01-01-2019	03-04-2019 (i.e. 05-03-2019 +30 Days)	200
M1	Premium Fee	04-04-2019 (New Born Considered for Premium Calculation)	31-12-2019	350

## Repricing

Oracle Revenue Management and Billing extends the Repricing feature for the insurance domain. To enable this feature for fully insured line of business, you need to setup the audit framework for membership and age based and tier based pricing rules. For more information, refer to the Audit Framework for Membership and Fully Insured Pricing Rules section.

To recalculate the membership premium, you need to execute the following batches in the specified order:

1. **Identify Entities for Repricing (C1-REPC1)** - Until now, this batch identified a set of accounts which were impacted due to change in a price list and then created a repricing request for such accounts. In this release, new parameters named **Repricing Mode** and **Membership ID** are added in this batch. If the **Repricing Mode** parameter is set to **ACCT**, this batch identifies a set of accounts which were impacted due to change in a price list and then creates a repricing request for such account. However, if the **Repricing Mode** parameter is set to **MEMB**, this batch considers the records in the **Pending (P)** and **Error (E)** status from the CI\_REPRC\_ENTITY\_DTL table. For each record, the system invokes the algorithms attached to the following system events of the pricing rule type in the specified order:
  - a. **Bill Group Derivation** – Used to derives the policy, bill group, and parent customer of the bill group.
  - b. **Account and Price Item Derivation** – Used to derive the pricing rules for the price items (which are present in the pricing rule type) on the policy plan (to which the membership belongs).

Once the pricing rules are derived, the system creates a repricing request for the membership, pricing rule, and effective date combination. Finally, the status of the corresponding record is set to **Complete (C)** in the CI\_REPRC\_ENTITY\_DTL table. If any error occurs while creating a repricing request, the status of the corresponding record is set to **Error (E)** in the CI\_REPRC\_ENTITY\_DTL table.

This batch is a multi-threaded batch. For more information about the batch, refer to *Oracle Revenue Management and Billing Batch Guide*.

2. **Process Repricing Request (C1-REPC2)** - Until now, this batch calculated and persisted the rate for the account, price item, and effective date combination in the CI\_PRCE\_CALC table. In this release, new parameters named **Repricing Mode** and **Membership ID** are added in this batch. If the **Repricing Mode** parameter is set to **ACCT**, this batch calculates and persist the rate for the account, price item, and effective date combination in the CI\_PRCE\_CALC table. However, if the **Repricing Mode** parameter is set to **MEMB**, this batch considers the records in the **Pending (P)** and **Error (E)** status from the CI\_REPRC\_REQ\_DTL table. If the pricing rule in the record is **Age Based**, the system invokes the algorithms attached to the following system events of the pricing rule type in the specified order:
  - a. **Pricing Rule Pre Processing** – Used to identify the eligible member persons for premium calculation.

**b. Pricing Rule Premium Calculation** – Used to calculate the premium for the membership.

Once these algorithms are executed, the premium is calculated for each eligible member person and stored in the CI\_PRCE\_CALC\_LN table and the total premium for the membership is stored in the CI\_PRCE\_CALC table. Finally, the status of the corresponding record is set to **Complete (C)** in the CI\_REPRC\_REQ\_DTL table.

However, if the pricing rule in the record is **Tier Based**, the system invokes the algorithm attached to the following system event of the pricing rule type:

- **Pricing Rule Premium Calculation** – Used to calculate the premium for the membership.

Once the algorithm is executed, the premium is calculated for the membership and stored in the CI\_PRCE\_CALC table. Finally, the status of the corresponding record is set to **Complete (C)** in the CI\_REPRC\_REQ\_DTL table.

This batch is a multi-threaded batch. For more information about the batch, refer to *Oracle Revenue Management and Billing Batch Guide*.

## Fully Insured Billable Charge Creation

Oracle Revenue Management and Billing enables you to create billable charges for pre-calculated premium amount (which is received through a healthcare inbound message) and calculated premium amount (which is derived using a pricing rule defined at the policy plan level). Before creating an SQI based billable charge, the system derives the bill period for the account using the **Invoice Day (C1OFFRST)** characteristic defined on the account.

While creating a billable charge for the pre-calculated premium amount through a healthcare inbound message, the system creates an SQI based billable charge for the membership and price item combination. Note that if the bill period or frequency is given in the billable charge information in the healthcare inbound message, the system does not derive the bill period for the account.

However, for creating a billable charge for the calculated premium amount, you need to execute the **Fully Insured Billable Charge Creation (C1-FIBCR)** batch. It creates an SQI based billable charge for calculated premium amount. It considers the timelines in the **Pending (P)** and **Error (E)** status from the CI\_PRCE\_CALC table. Note that it considers only those timelines where the entity type is set to **Membership**. For each timeline, membership and price item combination, the system does the following:

1. Derives the bill period for the account using the **Invoice Day (C1OFFRST)** characteristic defined on the account.
2. Creates an SQI based billable charge. Here, the start and end dates on the billable charge are set to the timeline start and end dates.

If the premium amount of the two consecutive timelines of a membership and price item combination is same, this algorithm does not create a new billable charge. Instead, it extends the end date of the previous timeline's billable charge. If the membership end date is set to a date which is earlier than the previous date (for example, Old Membership End Date: 31-12-2019 and New Membership End Date: 31-10-2019) and a billable charge exists for the membership and price item combination with the same start date and amount, then the system behaves in the following manner:

If...	Then...
Bill segments for the 01-01-2019 to 31-12-2019 period are not yet generated in the system	The end date in the existing billable charge is updated to 31-10-2019.
Bill segments for the 01-01-2019 to 31-12-2019 period are in the <b>Freezable</b> status	The bill segments for the 01-11-2019 to 31-12-2019 period are deleted and the end date in the existing billable charge is updated to 31-10-2019.
Bill segments for the 01-01-2019 to 31-12-2019 period are in the <b>Frozen</b> or <b>Pending Cancel</b> status	The bill segments for the 01-11-2019 to 31-12-2019 period are canceled and the end date in the existing billable charge is updated to 31-10-2019.

However, if the membership end date is set to a date which is earlier than the previous date (for example, Old Membership End Date: 31-12-2019 and New Membership End Date: 31-10-2019) and a billable charge exists for the

membership and price item combination with the same start date, but different amount, then the system behaves in the following manner:

<b>If...</b>	<b>Then...</b>
Bill segments for the 01-01-2019 to 31-12-2019 period are not yet generated in the system	The existing billable charge is canceled and a new billable charge is created for the 01-01-2019 to 31-10-2019 period.
Bill segments for the 01-01-2019 to 31-12-2019 period are in the <b>Freezable</b> status	The bill segments for the 01-01-2019 to 31-12-2019 period are deleted. The existing billable charge is canceled and a new billable charge is created for the 01-01-2019 to 31-10-2019 period.
Bill segments for the 01-01-2019 to 31-12-2019 period are in the <b>Frozen</b> or <b>Pending Cancel</b> status	The bill segments for the 01-01-2019 to 31-12-2019 period are canceled. The existing billable charge is canceled and a new billable charge is created for the 01-01-2019 to 31-10-2019 period.

And, if the membership end date is set to a date which is earlier than the previous date (for example, Old Membership End Date: 31-12-2019 and New Membership End Date: 31-10-2019) and a billable charge does not exist for the membership and price item combination with the same start date, then a billable charge is created for the 01-01-2019 to 31-10-2019 period. Note that if there are billable charges for the membership and price item combination whose date range is within the timeline, such billable charges are canceled and their corresponding bill segments (if any) are either deleted or canceled in the system.

The pre-calculated or calculated premium amount is stored as a pass through line in the SQI based billable charge. Note that these pass through lines are memo only and no general ledger entries will be created for these pass through lines. This algorithm fetches SQI from the **Proration SQI** option type of the **C1-ASOBLLNG** feature configuration. The SQI value is set to the total amount of the pass through lines in the billable charge. The system prorates the amount only when the SQ rule specified in the rate schedule attached to the active contract contains the SQI which is specified in the **Proration SQI** option type of the **C1-ASOBLLNG** feature configuration.

Once the billable charge is created, the membership ID is stamped as characteristic on the billable charge. This indicates that the billable charge is created for the respective membership. This algorithm fetches the characteristic type, which must be defined on the billable charge, from the **Characteristic Type For Membership Id** option type of the **C1-ASOBLLNG** feature configuration.

Finally, the status of the corresponding timeline is set to **Complete (C)** in the **CI\_PRCE\_CALC** table. If any error occurs while creating a billable charge, the status of the corresponding timeline is set to **Error (E)** in the **CI\_PRCE\_CALC** table. In addition, if an error occurs, a To Do is created using the **C1-FIBCR** To Do type and assigned to all users with a To Do role which is specified as characteristic on the parent customer. The system considers the characteristic on the parent customer which is specified in the **To Do Role Characteristic Type** option type of the **C1-ASOBLLNG** feature configuration. Note that the system does not create a To Do for each error record. Instead, the system creates distinct To Do for each membership and pricing rule combination.

This batch is a multi-threaded batch. For more information about the batch, refer to *Oracle Revenue Management and Billing Batch Guide*.



---

# Chapter 36

---

## Entity Audit

---

### Topics:

- [Audit Event Status Transition](#)
- [Prerequisites](#)
- [Entity Audit Process](#)
- [Algorithms Used in the Entity Audit Process](#)
- [Audit Event Type](#)
- [Audit Event \(Used for Searching\)](#)
- [Audit Event \(Used for Viewing\)](#)

Oracle Revenue Management and Billing provides a mechanism wherein auditors can track various actions, such as add, update, and delete for an entity. If the entity audit feature is enabled for a business object, the system creates audit events whenever you define, edit, or delete an entity (which is created using the respective business object). For example, if the entity audit feature is enabled for the **C1-Membership** business object, the system creates an audit event whenever you define, edit, or delete a membership in a policy plan or whenever you add or remove persons from a membership. For more information on how to enable the entity audit feature for a business object, see [Prerequisites](#) on page 2850.

The entity audit process is a two-step process, wherein the system creates the audit events and then processes them whenever the **Audit Event Processing (C1-AUDEV)** batch is executed. For more information about these processes, see the following sections:

- [Audit Event Creation](#) on page 2851
- [Audit Event Processing](#) on page 2852

During the entity audit process, each audit event goes through various statuses in its lifecycle. For more information about the audit event statuses, see [Audit Event Status Transition](#) on page 2850.

## Audit Event Status Transition

The following figure graphically indicates how an audit event moves from one status to another in its lifecycle:

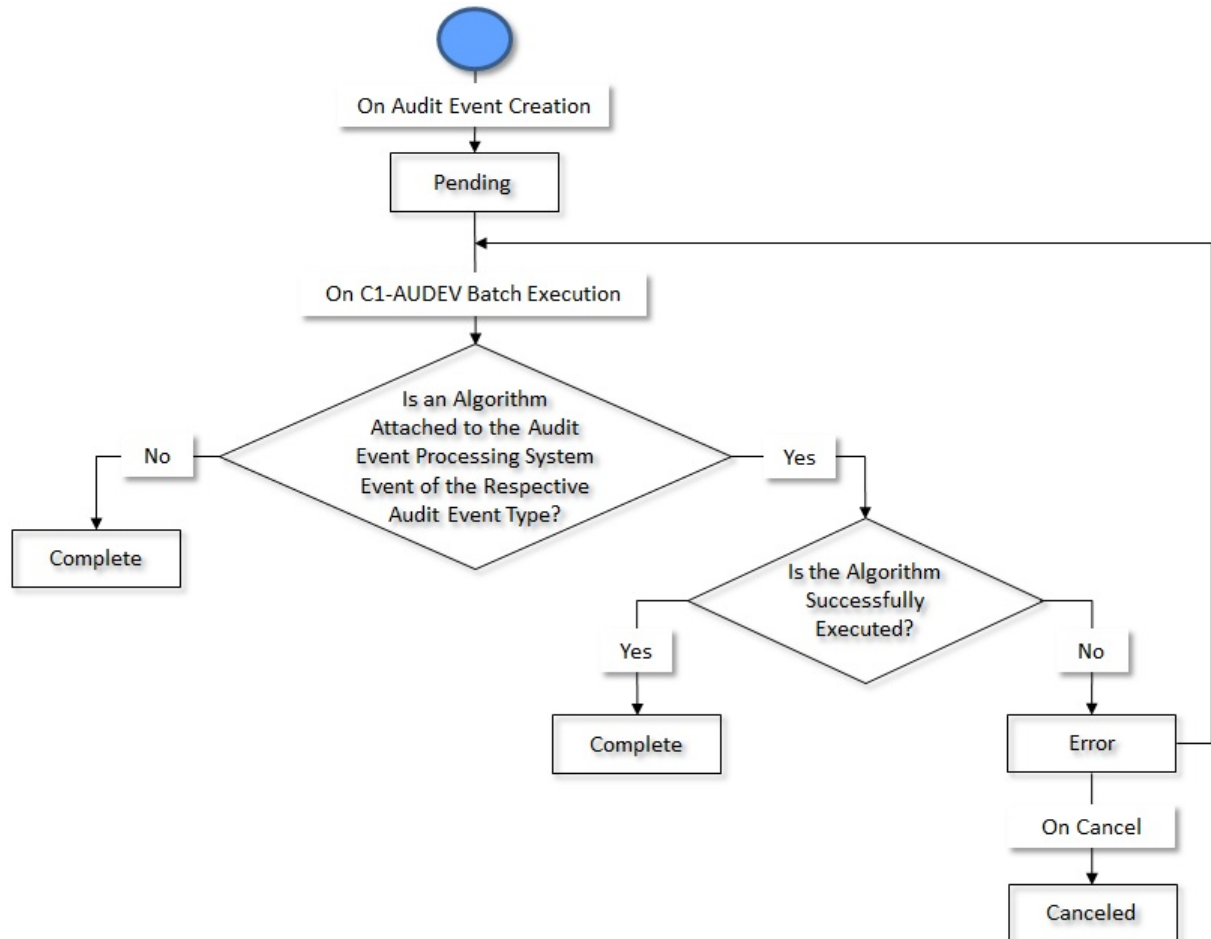

## Prerequisites

To setup the entity audit feature for a business object, you need to do the following:

- Set the **Eligible for Audit Event** option type of the entity business object to **Y**.

**Note:** The **Eligible for Audit Event** option type is available for the entity business object only when the **Valid BO Option Type** option type of the respective maintenance object is set to **C1AT**.

- Attach an algorithm created using the **C1-READEVNT** algorithm type to the **Audit** system event of the entity business object.

**Note:**

At present, this algorithm is designed to work with the following business objects:

- C1-POLICY
- C1-ASOPolicy
- C1-Membership
- C1-PolicyPlan
- C1\_PERSON\_BO
- C1-PricingRuleTierBased
- C1-PricingRuleAgeBased

If you want to use the audit algorithm for the business objects which are not listed above, you need to create a custom audit algorithm.

- Define an active audit event type for the entity business object in the system.
- Define the required algorithm types where the algorithm entity is set to **Audit Event Processing**.
- Create the required algorithms and attach them to the **Audit Event Processing** system event of the audit event type.

**Note:** The **C1-AUDEVMPR** algorithm type is shipped with the product. You must attach an algorithm created using the **C1-AUDEVMPR** algorithm type to the audit event types which are defined for the **C1-PricingRuleTierBased** and **C1-PricingRuleAgeBased** business objects.

- Define the values for the **AUDIT\_USAGE\_FLG** lookup field
- Define the required characteristic types where the characteristic entity is set to **Audit Event Type**.

## Entity Audit Process

---

The entity audit process consists of the following two sub-processes:

- [Audit Event Creation](#) on page 2851
- [Audit Event Processing](#) on page 2852

### Audit Event Creation

If you add, edit, or delete an entity which is created using a business object for which the entity audit feature is enabled, the system checks whether an active audit event type exists for the entity business object. If so, it considers the active audit event type and creates the audit event using the respective audit event type. The system creates the audit event while:

- Defining an entity when the **Add Action** option is selected in the audit event type
- Editing an entity when the **Update All** option is selected in the audit event type or when the updated element is listed in the **Audit Elements for Entity Update** section
- Deleting an entity when the **Delete Action** option is selected in the audit event type

For more information about the audit event type, see [Audit Event Type](#) on page 2853.

The audit event is created in the **Pending** status. Note that the system creates one audit event for the entity irrespective of the number of changes made during the entity update. The entity type and entity ID for which an audit event is created are added corresponding to the audit event in the **C1\_AUDIT\_EVENT** table. For example, if the audit event is created

while adding or updating a pricing rule, then the entity type is set to **Pricing Rule** and entity ID is set to the pricing rule ID. In addition, an effective date is stamped corresponding to the audit event in the **C1\_AUDIT\_EVENT** table. Note that if the entity has a start date, then the effective date is set to the entity's start date. But, if the entity does not have a start date, then the effective date is set to the system date.

At a time, you can have only two audit events for the entity in the **Pending** status — one audit event which is created during the **Add** action and another audit event which is created during the **Update** action.

**Note:** Before creating an audit event, the system checks whether an audit event for the entity ID with the same effective date already exists in the **Pending** or **Error** status for the respective action. If so, the system does not create a new audit event for the entity. Instead, the system adds a new log entry in the existing audit event.

## Audit Event Processing

On executing the **Audit Event Processing (C1-AUDEV)** batch, the system checks whether there are any audit events in the **Pending** status. If there is an audit event in the **Pending** status, the system checks whether an algorithm is attached to the **Audit Event Processing** system event of the respective audit event type. If an algorithm is not attached to the **Audit Event Processing** system event of the respective audit event type, the status of the audit event is set to **Complete**.

However, if an algorithm is attached to the **Audit Event Processing** system event of the respective audit event type, the system executes the algorithm and accordingly changes the status of the audit event to **Complete**. For example, while processing the audit events of the **C1-PricingRuleTierBased** and **C1-PricingRuleAgeBased** business objects, the system checks whether an algorithm is attached to the **Audit Event Processing** system event of the respective audit event type. If the **C1-AUDEVMPR** algorithm is attached to the audit event type, the system identifies the policy plan where the pricing rule is defined. Once the policy plan is identified, it extracts a list of membership defined on the policy plan and the pricing rule type using which the pricing rule is created. Then, the system creates an entry for each membership, pricing rule type, and effective date combination in the **CI\_REPRC\_ENTITY\_DTL** table. The status of these entries is set to **P**. Finally, the status of the audit event is set to **Complete**.

If any error occurs, the status of the audit event is set to **Error**. The system enables you to either reprocess or cancel the audit events which are in the **Error** status. On canceling an audit event, the status of the audit event is changed to **Canceled**.

For more information about the **Audit Event Processing (C1-AUDEV)** batch and its parameters, see *Oracle Revenue Management and Billing Batch Guide*.

## Algorithms Used in the Entity Audit Process

The following table lists the algorithms which are designed to implement the entity audit process:

Algorithm	Algorithm Type	Attached To	System Event	Algorithm Description
C1- REAUDEVNT	C1- REAUDEVNT	Entity Business Object	Audit	Refer to <a href="#">C1-REAUDEVNT</a> on page 2852.
C1- AUDEVMPR	C1- AUDEVMPR	Audit Event Type of the <b>C1-PricingRuleAgeBased</b> and <b>C1-PricingRuleTierBased</b> business objects	Audit Event Processing	Refer to <a href="#">C1-AUDEVMPR</a> on page 2853.

### C1-REAUDEVNT

If this algorithm is attached to the **Audit** system event of a business object, it is invoked whenever you define, edit, or delete the respective entity. It checks whether an active audit event type exists for the entity business object. If so, it considers the active audit event type and creates the audit event using the respective audit event type. The system creates the audit event while:

- Defining an entity when the **Add Action** option is selected in the audit event type
- Editing an entity when the **Update All** option is selected in the audit event type or when the updated element is listed in the **Audit Elements for Entity Update** section
- Deleting an entity when the **Delete Action** option is selected in the audit event type

The entity type and entity ID for which an audit event is created are added corresponding to the audit event in the **C1\_AUDIT\_EVENT** table. In addition, the effective date is stamped corresponding to the audit event in the **C1\_AUDIT\_EVENT** table. Note that if the entity has a start date, then the effective date is set to the entity's start date. But, if the entity does not have a start date, then the effective date is set to the system date.

**Note:** Before creating an audit event, the system checks whether an audit event for the entity ID with the same effective date already exists in the **Pending** or **Error** status for the respective action. If so, the system does not create a new audit event for the entity. Instead, the system adds a new log entry in the existing audit event.

At present, this algorithm is designed to work with the following business objects:

- C1-POLICY
- C1-ASOPolicy
- C1-Membership
- C1-PolicyPlan
- C1\_PERSON\_BO
- C1-PricingRuleTierBased
- C1-PricingRuleAgeBased

If you want to use the audit algorithm for the business objects which are not listed above, you need to create a custom audit algorithm.

It contains the following parameters:

- **Audit Event Business Object** – Used to specify the business object using which you want to create the audit event.
- **Audit Event Pending Status** – Used to specify the status in which you want to create the audit event. This parameter is also used for determining whether an audit event for the entity ID already exists in the system.
- **Audit Event Error Status** – Used to specify the status in which an audit event is transitioned when an error occurs while processing the audit event. This parameter is used for determining whether an audit event for the entity ID already exists in the system.

All the above parameters are mandatory.

## C1-AUDEVMPR

You must attach this algorithm to the **Audit Event Processing** system event while creating an audit event type for the **C1-PricingRuleAgeBased** and **C1-PricingRuleTierBased** business objects.

This algorithm is invoked when the **Audit Event Processing (C1-AUDEV)** batch is executed. If this algorithm is attached to the **Audit Event Processing** system event of the respective audit event type, the system identifies the policy plan where the pricing rule is defined. Once the policy plan is identified, it extracts a list of membership defined on the policy plan and the pricing rule type using which the pricing rule is created. Then, the system creates an entry for each membership, pricing rule type, and effective date combination in the **CI\_REPRC\_ENTITY\_DTL** table. The status of these entries is set to **P** in the **CI\_REPRC\_ENTITY\_DTL** table.

## Audit Event Type

---

Oracle Revenue Management and Billing enables you to define an audit event type for an entity business object. However, at a time, only one audit event type of the entity business object can be in the **Active** status. The system

creates an audit event using the active audit event type whenever you define, edit, or delete the respective entity. The audit event type helps the system to determine:

- **Entity Business Object** – The business object for which you want to define the audit event type.
- **Audit Usage** – The usage indicates the purpose of auditing an entity which is created using the entity business object. For example, membership premium charges might change due to change in pricing and therefore you may want to audit the pricing rules for premium calculation.
- **Audit Actions** – The various options, such as **Add Action**, **Delete Action**, and **Update All** are available while defining an audit event type. The system creates an audit event while defining, editing or deleting an entity depending on whether the respective option is selected in the audit event type. For example, if you create the active audit event types for the following entity business objects where the below listed options are selected:

Audit Event Type	Entity Business Object	Add Action	Update All	Delete Action
AETY1	C1-POLICY	Y	N	N
AETY2	C1-ASOPolicy	Y	Y	Y

Then, the system will create an audit event using the **AETY1** audit event type when you define a fully-insured policy. But, the system will not create an audit event when you edit or delete a fully-insured policy. However, the system will create an audit event using the **AETY2** audit event type when you define, edit, or delete a self-funded policy.

- **Audit Elements During Update** – Alternatively, you can list the elements of the entity business object which should be monitored for the auditing purpose while editing an entity in the audit event type. You can list the elements of the entity business object only when the **Update All** option is not selected. The system enables you to monitor a set of the business object statuses, characteristic types, and fields and accordingly creates an audit event while editing an entity. For example, if you create the audit event types for the following entity business objects:

Audit Event Type	Entity Business Object	Update All	Audit Elements During Update
AETY3	C1_PERSON_BO	Y	Not applicable
AETY4	C1-PricingRuleTierBased	N	Pricing Start Date, Rate Option, Base Fee for a Price Component
AETY5	C1-PricingRuleAgeBased	N	Rate Option, Base Fee for a Price Component

Then, the system will create an audit event using the **AETY3** audit event type when you edit any details of a person. But, the system will create an audit event using the **AETY4** audit event type only when the following fields in a tier based pricing rule are edited:

- Pricing Start Date
- Rate Option
- Base Fee for a Price Component

Similarly, the system will create an audit event using the **AETY5** audit event type only when the following fields in an age based pricing rule are edited:



- Rate Option
- Base Fee for a Price Component

The **Audit Event Type** screen allows you to define, edit, copy, and delete an audit event type. It contains the following zones:

- [Audit Event Type List](#) on page 2855
- [Audit Event Type](#) on page 2856

## Audit Event Type List

The **Audit Event Type List** zone lists the audit event types that are already defined in the system. It contains the following columns:

Column Name	Column Description
Audit Event Type	Displays the audit event type.
Description	Displays the description of the audit event type.
Entity Business Object	Indicates the business object for which the audit event type is created. In addition, this column has a context menu which helps in navigating to other screens in the application.  <b>Note:</b> It has a link. On clicking the link, the <b>Business Object</b> screen appears where you can view the details of the respective business object.
Status	Indicates the status of the audit event type. The valid values are: <ul style="list-style-type: none"> <li>Active</li> <li>Inactive</li> </ul>
Audit Usage	Indicates the purpose of auditing the entity business object. The valid value is: <ul style="list-style-type: none"> <li>Premium Calculation</li> </ul>
Edit	On clicking the <b>Edit</b> (  ) icon, the <b>Audit Event Type</b> screen appears where you can edit the details of the audit event type.  <b>Note:</b> You can edit an audit event type only when an audit event is not yet created using the audit event type. However, if an audit event is created using the audit event type, you can only do the following: <ul style="list-style-type: none"> <li>Change the status from <b>Active</b> to <b>Inactive</b> and vice-versa</li> <li>Attach algorithms (if required) to the audit event type</li> <li>Define, edit, or remove characteristics from the audit event type</li> </ul>
Duplicate	On clicking the <b>Duplicate</b> (  ) icon, the <b>Audit Event Type</b> screen appears where you can define a new audit event type using an existing audit event type.
Delete	On clicking the <b>Delete</b> (  ) icon, you can delete the audit event type.  <b>Note:</b> You can delete an audit event type only when an audit event is not yet created using the audit event type.

**Note:** Pagination is used to display limited number of records in this zone. You can use the navigation links, such as **Previous** and **Next** to navigate between pages.

You can filter the list using various search criteria (such as, **Status** and **Entity Business Object**) available in the **Filter** area. By default, the **Filter** area is hidden. You can view the **Filter** area by clicking the **Filters** () icon in the upper right corner of this zone.

On clicking the **Broadcast** () icon corresponding to an audit event type, the **Audit Event Type** zone appears with the details of the respective audit event type.

**Related Topics**

For more information on...	See...
How to edit an audit event type	<a href="#">Editing an Audit Event Type</a> on page 2866
How to copy an audit event type	<a href="#">Copying an Audit Event Type</a> on page 2868
How to delete an audit event type	<a href="#">Deleting an Audit Event Type</a> on page 2870
How to view the details of an audit event type	<a href="#">Viewing the Audit Event Type Details</a> on page 2871

**Audit Event Type**

The **Audit Event Type** zone displays the details of the audit event type. It contains the following sections:

- **Main** - Displays basic information about the audit event type. It contains the following fields:

Field Name	Field Description
Audit Event Type	Displays the audit event type.
Description	Displays the description of the audit event type.
Detailed Description	Displays additional information about the audit event type.
Status	Indicates the status of the audit event type. The valid values are: <ul style="list-style-type: none"> <li>• Active</li> <li>• Inactive</li> </ul>
Entity Business Object	Indicates the business object for which the audit event type is defined. In addition, this field has a context menu which helps in navigating to other screens in the application. <div style="border: 1px solid black; padding: 5px; margin-top: 10px;"> <p><b>Note:</b> It has a link. On clicking the link, the <b>Business Object</b> screen appears where you can view the details of the respective business object.</p> </div>
Audit Usage	Indicates the purpose of auditing the entity business object. The valid value is: <ul style="list-style-type: none"> <li>• Premium Calculation</li> </ul>
Update All	Indicates whether an audit event must be created whenever any field, characteristic, or status of the entity is updated.
Add Action	Indicates whether an audit event must be created whenever an entity is added.
Delete Action	Indicate whether an audit event must be created whenever an entity is deleted.

- **Algorithms** - Lists the algorithms associated with the audit event type. It contains the following columns:

Column Name	Column Description
System Event	Indicates the system event when the algorithm must be triggered. The valid value is: <ul style="list-style-type: none"> <li>• Audit Event Processing</li> </ul>
Sequence	Indicates the order in which the algorithms with the same system event must be triggered.



Column Name	Column Description
Algorithm	Indicates the algorithm attached to the system event.  <b>Note:</b> It has a link. On clicking the link, the <b>Algorithm</b> screen appears where you can view the details of the respective algorithm.

- **Audit Elements for Entity Update** - Lists the elements which must be monitored for auditing while updating the entity. It contains the following columns:

Column Name	Column Description						
Element Type	Indicates the type of element. The valid values are: <ul style="list-style-type: none"> <li>• Business Object Status</li> <li>• Characteristic</li> <li>• Field</li> </ul>						
Element Name	Displays the element which must be monitored for auditing.  <b>Note:</b> If the element is a part of a group or list, the system displays the element name along with the element group and/or list. For example, if you select the <b>policyPerRole</b> element of the <b>C1-ASOPolicy</b> business object, the system displays the <code>policyPersons/policyPerRole</code> in the <b>Element Name</b> field. Here, the <b>policyPersons</b> is the element list.						
Element Value	The following table lists the element value depending on the element type: <table border="1" data-bbox="643 1026 1463 1274"> <thead> <tr> <th>Element Type</th> <th>Element Value</th> </tr> </thead> <tbody> <tr> <td>Business Object Status</td> <td>Indicates the status of the entity business object which must be monitored for auditing.</td> </tr> <tr> <td>Characteristic</td> <td>Indicates the characteristic type which must be monitored for auditing.</td> </tr> </tbody> </table> <b>Note:</b> The data does not appear in this column when the element type is set to <b>Field</b> .	Element Type	Element Value	Business Object Status	Indicates the status of the entity business object which must be monitored for auditing.	Characteristic	Indicates the characteristic type which must be monitored for auditing.
Element Type	Element Value						
Business Object Status	Indicates the status of the entity business object which must be monitored for auditing.						
Characteristic	Indicates the characteristic type which must be monitored for auditing.						

- **Characteristics** - Lists the characteristics which are defined for the audit event type. It contains the following columns:

Column Name	Column Description
Characteristic Type	Indicates the characteristic type.
Characteristic Value	Displays the value of the characteristic type.

- **Record Actions** - This section contains the following buttons:

Button Name	Button Description
Edit	Used to edit the details of the audit event type.  <b>Note:</b> You can edit an audit event type only when an audit event is not yet created using the audit event type. However, if an audit event is created using the audit event type, you can only do the following: <ul style="list-style-type: none"> <li>• Change the status from <b>Active</b> to <b>Inactive</b> and vice-versa</li> <li>• Attach algorithms (if required) to the audit event type</li> <li>• Define, edit, or remove characteristics from the audit event type</li> </ul>
Delete	Used to delete the audit event type.  <b>Note:</b> You can delete an audit event type only when an audit event is not yet created using the audit event type.
Duplicate	Used to create a new audit event type using an existing audit event type.

- **Record Information** - This section contains the following field:

Field Name	Field Description
Business Object	Indicates the business object using which the audit event type is created. In addition, a context menu appears corresponding to this field which helps in navigating to other screens in the application.  <b>Note:</b> It has a link. On clicking the link, the <b>Business Object</b> screen appears where you can view the details of the respective business object.

By default, the **Audit Event Type** zone does not appear in the **Audit Event Type** screen. It appears only when you click the **Broadcast**  icon corresponding to an audit event type in the **Audit Event Type List** zone.

### Related Topics

For more information on...	See...
How to edit an audit event type	<a href="#">Editing an Audit Event Type</a> on page 2866
How to copy an audit event type	<a href="#">Copying an Audit Event Type</a> on page 2868
How to delete an audit event type	<a href="#">Deleting an Audit Event Type</a> on page 2870
How to view the details of an audit event type	<a href="#">Viewing the Audit Event Type Details</a> on page 2871

## Defining an Audit Event Type

### Prerequisites

To define an audit event type, you should have:

- Entity business objects defined in the application
- The **Eligible for Audit Event** option type of the entity business object (for which you want to define an audit event type) set to **Y**

**Note:** The **Eligible for Audit Event** option type is available for the entity business object only when the **Valid BO Option Type** option type of the respective maintenance object is set to **CIAT**.

- Values defined for the **AUDIT\_USAGE\_FLG** lookup field

### **Procedure**

To define an audit event type:

1. Click the **Admin** link in the **Application** toolbar.  
A list appears.
2. From the **Admin** menu, select **A** and then click **Audit Event Type**.  
A sub-menu appears.
3. Click the **Add** option from the **Audit Event Type** sub-menu.

The **Audit Event Type** screen appears. It contains the following sections:

- **Main** - Used to specify basic information about the audit event type.
- **Algorithms** - Used to associate algorithms with the audit event type.
- **Audit Elements for Entity Update** - Used to list the elements from the entity business object which you want to monitor for auditing while updating the entity.

**Note:** The **Audit Elements for Entity Update** section is enabled only when the **Update All** option is not selected in the **Main** section.

- **Characteristics** - Used to define characteristics for the audit event type.

The **Main** section contains the following fields:

<b>Field Name</b>	<b>Field Description</b>	<b>Mandatory (Yes or No)</b>
Audit Event Type	Used to specify the audit event type.  <b>Note:</b> You cannot specify any special characters except hyphen and underscore in the audit event type.	Yes
Business Object	Indicates the business object using which you are defining the audit event type.	Not applicable
Description	Used to specify the description for the audit event type.	Yes
Detailed Description	Used to specify additional information about the audit event type.	No
Status	Used to indicate the status of the audit event type. The valid values are: <ul style="list-style-type: none"> <li>• Active</li> <li>• Inactive</li> </ul> <b>Note:</b> You can create only one audit event type in the <b>Active</b> status for an entity business object.	Yes

Field Name	Field Description	Mandatory (Yes or No)
Entity Business Object	Used to indicate the business object for which you want to define the audit event type.  <b>Note:</b> The list includes only those business objects where the <b>Eligible for Audit Event</b> option type is set to <b>Y</b> .	Yes
Audit Usage	Used to indicate the purpose of auditing the entity business object. The valid value is: <ul style="list-style-type: none"> <li>Premium Calculation</li> </ul>	Yes
Update All	Used to indicate whether you want to create an audit event whenever any field, characteristic, or status of the entity is updated.	No
Add Action	Used to indicate whether you want to create an audit event whenever the entity is added.	Yes (Conditional)  <b>Note:</b> This field is required when you want to create an audit event while adding the entity.
Delete Action	Used to indicate whether you want to create an audit event whenever the entity is deleted.	Yes (Conditional)  <b>Note:</b> This field is required when you want to create an audit event while deleting the entity.

**Tip:** Alternatively, you can access this screen by clicking the **Add** button in the **Page Title** area of the **Audit Event Type** screen.

- Enter the required details in the **Main** section.
- Associate the required algorithms with the audit event type.
- Add elements (such as, field, characteristic, or status) which you want to monitor for auditing while updating the entity.

**Note:** You can list the elements for auditing only when the **Update All** option is not selected in the **Main** section.

- Define characteristics for the audit event type, if required.
- Click **Save**.

The audit event type is defined.

### **Related Topics**

For more information on...	See...
<b>Audit Event Type</b> screen	<a href="#">Audit Event Type</a> on page 2853
How to associate an algorithm with an audit event type	<a href="#">Associating an Algorithm with an Audit Event Type</a> on page 2861
How to add an element for auditing in an audit event type	<a href="#">Adding an Element for Auditing in an Audit Event Type</a> on page 2862
How to define a characteristic for an audit event type	<a href="#">Defining a Characteristic for an Audit Event Type</a> on page 2865

## Associating an Algorithm with an Audit Event Type

### Prerequisites

To associate an algorithm with an audit event type, you should have:

- Algorithms defined in the application (which are created using an algorithm type where the algorithm entity is set to **Audit Event Processing**)

**Note:** The **C1-AUDEVMPR** algorithm type is shipped with the product. You must attach an algorithm created using the **C1-AUDEVMPR** algorithm type to the audit event types which are defined for the **C1-PricingRuleTierBased** and **C1-PricingRuleAgeBased** business objects.

### Procedure

To associate an algorithm with an audit event type:

- Ensure that the **Algorithms** section is expanded when you are defining, editing, or copying an audit event type.

The **Algorithms** section contains the following fields in a grid:

Field Name	Field Description	Mandatory (Yes or No)
System Event	Used to indicate the system event when you want to trigger the algorithm. The valid value is: <ul style="list-style-type: none"> <li><b>Audit Event Processing</b> - Used when you want to trigger the attached algorithm while executing the <b>Audit Event Process Monitor (C1-AUDEV)</b> batch.</li> </ul>	Yes (Conditional) <div style="border: 1px solid black; padding: 5px; margin-top: 5px;"> <p><b>Note:</b> This field is required when you are associating an algorithm with the audit event type.</p> </div>
Sequence	Used to indicate the order in which the algorithms with the same system event should be triggered.	Yes (Conditional) <div style="border: 1px solid black; padding: 5px; margin-top: 5px;"> <p><b>Note:</b> This field is required when you are associating an algorithm with the audit event type.</p> </div>
Algorithm	Used to indicate the algorithm that you want to attach to the system event. <div style="border: 1px solid black; padding: 5px; margin-top: 5px;"> <p><b>Note:</b></p> <p>Once you select the system event, the <b>Search</b>  icon appears corresponding to the <b>Algorithm</b> field. On clicking the <b>Search</b> icon, the <b>Algorithm Search</b> window appears.</p> <p>On specifying the algorithm, the description of the algorithm appears corresponding to the <b>Algorithm</b> field.</p> </div>	Yes (Conditional) <div style="border: 1px solid black; padding: 5px; margin-top: 5px;"> <p><b>Note:</b> This field is required when you are associating an algorithm with the audit event type.</p> </div>

- Enter the required details in the **Algorithms** section.
- If you want to associate more than one algorithm with the audit event type, click the **Add**  icon, and then repeat step 2.

**Note:** However, if you want to remove an algorithm from the audit event type, click the **Delete**  icon corresponding to the algorithm.

### Related Topics

For more information on...	See...
How to define an audit event type	<a href="#">Defining an Audit Event Type</a> on page 2858
How to edit an audit event type	<a href="#">Editing an Audit Event Type</a> on page 2866
How to copy an audit event type	<a href="#">Copying an Audit Event Type</a> on page 2868

## Adding an Element for Auditing in an Audit Event Type

### Prerequisites

To add an element for auditing in an audit event type, you should have:

- Required elements defined in the entity business object schema
- Required statuses defined in the lifecycle of the entity business object
- Required characteristic types defined in the application (where the characteristic entity is set to the respective entity)

### Procedure



To add an element for auditing in an audit event type:

1. Ensure that the **Audit Elements for Entity Update** section is expanded when you are defining, editing, or copying an audit event type.

The **Audit Elements for Entity Update** section contains the following fields in a grid:

Field Name	Field Description	Mandatory (Yes or No)
Element Type	Used to indicate the type of element. The valid values are: <ul style="list-style-type: none"> <li>• Business Object Status</li> <li>• Characteristic</li> <li>• Field</li> </ul>	Yes (Conditional) <div style="border: 1px solid black; padding: 5px; margin-top: 5px;"> <p><b>Note:</b> This field is required when you want to create an audit event whenever the specified element is updated.</p> </div>

Field Name	Field Description	Mandatory (Yes or No)								
Element Name	<p>Used to specify the element which you want to monitor while updating the entity. The following table lists the elements which you must select for the respective element type:</p> <table border="1" data-bbox="545 359 1182 1226"> <thead> <tr> <th data-bbox="545 359 776 411">Element Type</th> <th data-bbox="776 359 1182 411">Element Name</th> </tr> </thead> <tbody> <tr> <td data-bbox="545 411 776 495">Business Object Status</td> <td data-bbox="776 411 1182 495">boStatus</td> </tr> <tr> <td data-bbox="545 495 776 579">Characteristic</td> <td data-bbox="776 495 1182 579">characteristics/characteristicsList/ characteristicType</td> </tr> <tr> <td data-bbox="545 579 776 1226">Field</td> <td data-bbox="776 579 1182 1226">           Any field from the entity business object schema           <div data-bbox="792 663 1166 1205" style="border: 1px solid black; padding: 5px;"> <p><b>Note:</b> Here, you must not specify an element whose type is set to <b>group</b> or <b>list</b>. If the element is a part of a group or list, the system displays the element name along with the element group and/or list. For example, if you select the <b>policyPerRole</b> element of the <b>C1-ASOPolicy</b> business object, the system displays the <b>policyPersons/policyPerRole</b> in the <b>Element Name</b> field. Here, the <b>policyPersons</b> is the element list.</p> </div> </td> </tr> </tbody> </table>	Element Type	Element Name	Business Object Status	boStatus	Characteristic	characteristics/characteristicsList/ characteristicType	Field	Any field from the entity business object schema <div data-bbox="792 663 1166 1205" style="border: 1px solid black; padding: 5px;"> <p><b>Note:</b> Here, you must not specify an element whose type is set to <b>group</b> or <b>list</b>. If the element is a part of a group or list, the system displays the element name along with the element group and/or list. For example, if you select the <b>policyPerRole</b> element of the <b>C1-ASOPolicy</b> business object, the system displays the <b>policyPersons/policyPerRole</b> in the <b>Element Name</b> field. Here, the <b>policyPersons</b> is the element list.</p> </div>	<p>Yes (Conditional)</p> <div data-bbox="1206 296 1463 470" style="border: 1px solid black; padding: 5px;"> <p><b>Note:</b> This field is required when you want to create an audit event whenever the specified element is updated.</p> </div>
Element Type	Element Name									
Business Object Status	boStatus									
Characteristic	characteristics/characteristicsList/ characteristicType									
Field	Any field from the entity business object schema <div data-bbox="792 663 1166 1205" style="border: 1px solid black; padding: 5px;"> <p><b>Note:</b> Here, you must not specify an element whose type is set to <b>group</b> or <b>list</b>. If the element is a part of a group or list, the system displays the element name along with the element group and/or list. For example, if you select the <b>policyPerRole</b> element of the <b>C1-ASOPolicy</b> business object, the system displays the <b>policyPersons/policyPerRole</b> in the <b>Element Name</b> field. Here, the <b>policyPersons</b> is the element list.</p> </div>									
<div data-bbox="545 1251 1182 1526" style="border: 1px solid black; padding: 5px;"> <p><b>Note:</b></p> <p>The <b>Search</b>  icon appears corresponding to the <b>Element Name</b> field. On clicking the <b>Search</b> icon, the <b>Schema</b> window appears.</p> <p>The <b>Schema</b> window does not appear when the entity business object is not specified in the <b>Main</b> section.</p> </div>										

Field Name	Field Description	Mandatory (Yes or No)						
Element Value	<p>Used to specify the element value depending on the element type. The following table lists the element value that you must specify depending on the element type:</p> <table border="1"> <thead> <tr> <th>Element Type</th> <th>Element Value</th> </tr> </thead> <tbody> <tr> <td>Business Object Status</td> <td>Used to indicate the status of the entity business object which you want to monitor for auditing. The system then creates an audit event whenever the entity is transitioned to the specified status.</td> </tr> <tr> <td>Characteristic</td> <td> <p>Used to indicate the characteristic type which you want to monitor for auditing. Here, you must specify a characteristic type where the characteristic entity is set to the respective entity. The system then creates an audit event whenever the specified characteristic is defined, edited, or removed from the entity.</p> <p><b>Note:</b> The <b>Search</b>  icon appears corresponding to the <b>Element Value</b> field. On clicking the <b>Search</b> icon, the <b>Characteristic Type Search</b> window appears.</p> </td> </tr> </tbody> </table> <p><b>Note:</b> This field does not appear when the <b>Field</b> option is selected from the <b>Element Type</b> list.</p>	Element Type	Element Value	Business Object Status	Used to indicate the status of the entity business object which you want to monitor for auditing. The system then creates an audit event whenever the entity is transitioned to the specified status.	Characteristic	<p>Used to indicate the characteristic type which you want to monitor for auditing. Here, you must specify a characteristic type where the characteristic entity is set to the respective entity. The system then creates an audit event whenever the specified characteristic is defined, edited, or removed from the entity.</p> <p><b>Note:</b> The <b>Search</b>  icon appears corresponding to the <b>Element Value</b> field. On clicking the <b>Search</b> icon, the <b>Characteristic Type Search</b> window appears.</p>	<p>Yes (Conditional)</p> <p><b>Note:</b> This field is required when you want to create an audit event whenever the specified element is updated.</p>
Element Type	Element Value							
Business Object Status	Used to indicate the status of the entity business object which you want to monitor for auditing. The system then creates an audit event whenever the entity is transitioned to the specified status.							
Characteristic	<p>Used to indicate the characteristic type which you want to monitor for auditing. Here, you must specify a characteristic type where the characteristic entity is set to the respective entity. The system then creates an audit event whenever the specified characteristic is defined, edited, or removed from the entity.</p> <p><b>Note:</b> The <b>Search</b>  icon appears corresponding to the <b>Element Value</b> field. On clicking the <b>Search</b> icon, the <b>Characteristic Type Search</b> window appears.</p>							

**Note:** The **Audit Elements for Entity Update** section is enabled only when the **Update All** option is not selected in the **Main** section.

- Enter the required details in the **Audit Elements for Entity Update** section.
- If you want to add more than one element for auditing in the audit event type, click the **Add**  icon and then repeat step 2.

**Note:** However, if you want to remove an element from the audit event type, click the **Delete**  icon corresponding to the element.

### Related Topics

For more information on...	See...
How to define an audit event type	<a href="#">Defining an Audit Event Type</a> on page 2858



For more information on...	See...
How to edit an audit event type	<a href="#">Editing an Audit Event Type</a> on page 2866
How to copy an audit event type	<a href="#">Copying an Audit Event Type</a> on page 2868

## Defining a Characteristic for an Audit Event Type

### Prerequisites

To define a characteristic for an audit event type, you should have:

- Characteristic types defined in the application (where the characteristic entity is set to **Audit Event Type**)

### Procedure

To define a characteristic for an audit event type:

1. Ensure that the **Characteristics** section is expanded when you are defining, editing, or copying an audit event type.

The **Characteristics** section contains the following fields in a grid:

Field Name	Field Description	Mandatory (Yes or No)
Characteristic Type	Used to indicate the characteristic type.  <b>Note:</b> The list includes only those characteristic types where the characteristic entity is set to <b>Audit Event Type</b> .	Yes (Conditional)  <b>Note:</b> This field is required when you are defining a characteristic for the audit event type.
Characteristic Value	Used to specify the value for the characteristic type.  <b>Note:</b> If you select a predefined characteristic type, the <b>Search</b> (🔍) icon appears corresponding to the <b>Characteristic Value</b> field. On clicking the <b>Search</b> icon, the <b>Predefined Characteristic Search</b> window appears where you can search for a predefined characteristic value.  On specifying the value for a predefined characteristic type, the description of the characteristic value appears corresponding to the <b>Characteristic Value</b> field.	Yes (Conditional)  <b>Note:</b> This field is required when you are defining a characteristic for the audit event type.

2. Enter the required details in the **Characteristics** section.
3. If you want to define more than one characteristic for the audit event type, click the **Add** (+) icon, and then repeat step 2.

**Note:** However, if you want to remove a characteristic from the audit event type, click the **Delete** (🗑️) icon corresponding to the characteristic.

### Related Topics

For more information on...	See...
How to define an audit event type	<a href="#">Defining an Audit Event Type</a> on page 2858
How to edit an audit event type	<a href="#">Editing an Audit Event Type</a> on page 2866
How to copy an audit event type	<a href="#">Copying an Audit Event Type</a> on page 2868

## Editing an Audit Event Type

You can edit an audit event type only when an audit event is not yet created using the audit event type. However, if an audit event is created using the audit event type, you can only do the following:

- Change the status from **Active** to **Inactive** and vice-versa
- Attach algorithms (if required) to the audit event type
- Define, edit, or remove characteristics from the audit event type

### Prerequisites

To edit an audit event type, you should have:

- Values defined for the **AUDIT\_USAGE\_FLG** lookup field

### Procedure

To edit an audit event type:

1. Click the **Admin** link in the **Application** toolbar.

A list appears.

2. From the **Admin** menu, select **A** and then click **Audit Event Type**.

A sub-menu appears.

3. Click the **Search** option from the **Audit Event Type** sub-menu.

The **Audit Event Type** screen appears.

4. In the **Audit Event Type List** zone, click the **Edit**  icon in the **Edit** column corresponding to the audit event type whose details you want to edit.

The **Audit Event Type** screen appears. It contains the following sections:

- **Main** - Used to specify basic information about the audit event type.
- **Algorithms** - Used to associate algorithms with the audit event type.
- **Audit Elements for Entity Update** - Used to list the elements from the entity business object which you want to monitor for auditing while updating the entity.

**Note:** The **Audit Elements for Entity Update** section is enabled only when the **Update All** option is not selected in the **Main** section.

- **Characteristics** - Used to define characteristics for the audit event type.

The **Main** section contains the following fields:

Field Name	Field Description	Mandatory (Yes or No)
Audit Event Type	Displays the audit event type.	Not applicable
Business Object	Indicates the business object which is used while defining the audit event type.	Not applicable

Field Name	Field Description	Mandatory (Yes or No)
Description	Used to specify the description for the audit event type.	Yes
Detailed Description	Used to specify additional information about the audit event type.	No
Status	Used to indicate the status of the audit event type. The valid values are: <ul style="list-style-type: none"> <li>Active</li> <li>Inactive</li> </ul> <div style="border: 1px solid black; padding: 2px; margin-top: 5px;"><b>Note:</b> You can create only one audit event type in the <b>Active</b> status for an entity business object.</div>	Yes
Entity Business Object	Indicates the business object for which the audit event type is defined.	Not applicable
Audit Usage	Used to indicate the purpose of auditing the entity business object. The valid value is: <ul style="list-style-type: none"> <li>Premium Calculation</li> </ul>	Yes
Update All	Used to indicate whether you want to create an audit event whenever any field, characteristic, or status of the entity is updated.	No
Add Action	Used to indicate whether you want to create an audit event whenever the entity is added.	Yes (Conditional) <div style="border: 1px solid black; padding: 2px; margin-top: 5px;"><b>Note:</b> This field is required when you want to create an audit event while adding the entity.</div>
Delete Action	Used to indicate whether you want to create an audit event whenever the entity is deleted.	Yes (Conditional) <div style="border: 1px solid black; padding: 2px; margin-top: 5px;"><b>Note:</b> This field is required when you want to create an audit event while deleting the entity.</div>

**Tip:** Alternatively, you can access this screen by clicking the **Edit** button in the **Audit Event Type** zone.

- Modify the required details in the **Main** section.
- Associate or disassociate the required algorithms from the audit event type.

**Note:** If an audit event is created using the audit event type, you cannot edit or remove algorithms from the audit event type. In such case, you can only associate additional algorithms with the audit event type.

- Add, edit, or remove elements from the audit event type, if required.

**Note:**

The **Audit Elements for Entity Update** section is enabled only when the **Update All** option is not selected in the **Main** section.

You cannot add, edit, or remove elements from the **Audit Elements for Entity Update** section when an audit event is already created using the audit event type.

- Define, edit, or remove characteristics from the audit event type, if required.

**Note:** You cannot define, edit, or remove characteristics from the **Characteristics** section when an audit event is already created using the audit event type.

- Click **Save**.

The changes made to the audit event type are saved.

### **Related Topics**

<b>For more information on...</b>	<b>See...</b>
<b>Audit Event Type</b> screen	<a href="#">Audit Event Type</a> on page 2853
<b>Audit Event Type List</b> zone	<a href="#">Audit Event Type List</a> on page 2855
<b>Audit Event Type</b> zone	<a href="#">Audit Event Type</a> on page 2856
How to associate an algorithm with an audit event type	<a href="#">Associating an Algorithm with an Audit Event Type</a> on page 2861
How to add an element for auditing in an audit event type	<a href="#">Adding an Element for Auditing in an Audit Event Type</a> on page 2862
How to define a characteristic for an audit event type	<a href="#">Defining a Characteristic for an Audit Event Type</a> on page 2865

## **Copying an Audit Event Type**

Instead of creating an audit event type from scratch, you can create a new audit event type using an existing audit event type. This is possible through copying an audit event type. On copying an audit event type, the details including the algorithms, audit elements, and characteristics are copied to the new audit event type. You can then edit the details, if required.

### **Prerequisites**

To copy an audit event type, you should have:

- Audit event type (whose copy you want to create) defined in the application
- Entity business objects defined in the application
- The **Eligible for Audit Event** option type of the entity business object (for which you want to define an audit event type) set to **Y**

**Note:** The **Eligible for Audit Event** option type is available for the entity business object only when the **Valid BO Option Type** option type of the respective maintenance object is set to **CIAT**.

- Values defined for the **AUDIT\_USAGE\_FLG** lookup field

### **Procedure**

To copy an audit event type:

- Click the **Admin** link in the **Application** toolbar.  
A list appears.
- From the **Admin** menu, select **A** and then click **Audit Event Type**.  
A sub-menu appears.
- Click the **Search** option from the **Audit Event Type** sub-menu.  
The **Audit Event Type** screen appears.

4. In the **Audit Event Type List** zone, click the **Duplicate** () icon in the **Duplicate** column corresponding to the audit event type whose copy you want to create.

The **Audit Event Type** screen appears. It contains the following sections:

- **Main** - Used to specify basic information about the audit event type.
- **Algorithms** - Used to associate algorithms with the audit event type.
- **Audit Elements for Entity Update** - Used to list the elements from the entity business object which you want to monitor for auditing while updating the entity.

**Note:** The **Audit Elements for Entity Update** section is enabled only when the **Update All** option is not selected in the **Main** section.

- **Characteristics** - Used to define characteristics for the audit event type.

The **Main** section contains the following fields:

Field Name	Field Description	Mandatory (Yes or No)
Audit Event Type	Used to specify the audit event type.  <b>Note:</b> You cannot specify any special characters except hyphen and underscore in the audit event type.	Yes
Business Object	Indicates the business object which is used while defining the audit event type.	Not applicable
Description	Used to specify the description for the audit event type.	Yes
Detailed Description	Used to specify additional information about the audit event type.	No
Status	Used to indicate the status of the audit event type. The valid values are: <ul style="list-style-type: none"> <li>• Active</li> <li>• Inactive</li> </ul> <b>Note:</b> You can create only one audit event type in the <b>Active</b> status for an entity business object.	Yes
Entity Business Object	Used to indicate the business object for which you want to define the audit event type.  <b>Note:</b> The list includes only those business objects where the <b>Eligible for Audit Event</b> option type is set to <b>Y</b> .	Yes
Audit Usage	Used to indicate the purpose of auditing the entity business object. The valid value is: <ul style="list-style-type: none"> <li>• Premium Calculation</li> </ul>	Yes
Update All	Used to indicate whether you want to create an audit event whenever any field, characteristic, or status of the entity is updated.	No

Field Name	Field Description	Mandatory (Yes or No)
Add Action	Used to indicate whether you want to create an audit event whenever the entity is added.	Yes (Conditional) <b>Note:</b> This field is required when you want to create an audit event while adding the entity.
Delete Action	Used to indicate whether you want to create an audit event whenever the entity is deleted.	Yes (Conditional) <b>Note:</b> This field is required when you want to create an audit event while deleting the entity.

**Tip:** Alternatively, you can copy an audit event type by clicking the **Duplicate** button in the **Audit Event Type** zone.

- Enter the required details in the **Main** section.
- Associate or disassociate the required algorithms from the audit event type.
- Add, edit, or remove elements from the audit event type, if required.

**Note:** The **Audit Elements for Entity Update** section is enabled only when the **Update All** option is not selected in the **Main** section.

- Define, edit, or remove characteristics from the audit event type, if required.
- Click **Save**.

The new audit event type is defined.

### Related Topics

For more information on...	See...
<b>Audit Event Type</b> screen	<a href="#">Audit Event Type</a> on page 2853
<b>Audit Event Type List</b> zone	<a href="#">Audit Event Type List</a> on page 2855
<b>Audit Event Type</b> zone	<a href="#">Audit Event Type</a> on page 2856
How to associate an algorithm with an audit event type	<a href="#">Associating an Algorithm with an Audit Event Type</a> on page 2861
How to add an element for auditing in an audit event type	<a href="#">Adding an Element for Auditing in an Audit Event Type</a> on page 2862
How to define a characteristic for an audit event type	<a href="#">Defining a Characteristic for an Audit Event Type</a> on page 2865

## Deleting an Audit Event Type

### Procedure

To delete an audit event type:

- Click the **Admin** link in the **Application** toolbar.  
A list appears.
- From the **Admin** menu, select **A** and then click **Audit Event Type**.

A sub-menu appears.

- Click the **Search** option from the **Audit Event Type** sub-menu.

The **Audit Event Type** screen appears.

- In the **Audit Event Type List** zone, click the **Delete** () icon in the **Delete** column corresponding to the audit event type that you want to delete.

A message appears confirming whether you want to delete the audit event type.

**Note:** You can delete an audit event type only when an audit event is not yet created using the audit event type.

**Tip:** Alternatively, you can delete an audit event type by clicking the **Delete** button in the **Audit Event Type** zone.

- Click **OK**.

The audit event type is deleted.

### Related Topics

For more information on...	See...
<b>Audit Event Type</b> screen	<a href="#">Audit Event Type</a> on page 2853
<b>Audit Event Type List</b> zone	<a href="#">Audit Event Type List</a> on page 2855
<b>Audit Event Type</b> zone	<a href="#">Audit Event Type</a> on page 2856

## Viewing the Audit Event Type Details

### Procedure

To view the details of an audit event type:

- Click the **Admin** link in the **Application** toolbar.

A list appears.

- From the **Admin** menu, select **A** and then click **Audit Event Type**.

A sub-menu appears.

- Click the **Search** option from the **Audit Event Type** sub-menu.

The **Audit Event Type** screen appears.

- In the **Audit Event Type List** zone, click the

**Broadcast** () icon corresponding to the audit event type whose details you want to view.

The **Audit Event Type** zone appears.

- View the details of the audit event type in the **Audit Event Type** zone.

### Related Topics

For more information on...	See...
<b>Audit Event Type</b> screen	<a href="#">Audit Event Type</a> on page 2853
<b>Audit Event Type List</b> zone	<a href="#">Audit Event Type List</a> on page 2855
<b>Audit Event Type</b> zone	<a href="#">Audit Event Type</a> on page 2856

## Audit Event (Used for Searching)

The **Audit Event** screen allows you to search for an audit event using various search criteria. It contains the following zone:

- [Search Audit Event](#) on page 2872

Through this screen, you can navigate to the following screen:

- [Audit Event \(Used for Viewing\)](#) on page 2875

### Related Topics

For more information on...	See...
How to search for an audit event	<a href="#">Searching for an Audit Event</a> on page 2874
How to view the details of an audit event	<a href="#">Viewing the Audit Event Details</a> on page 2875

## Search Audit Event

The **Search Audit Event** zone allows you to search for an audit event using various search criteria. It contains the following two sections:

- **Search Criteria** - The **Search Criteria** section contains the following fields:

Field Name	Field Description	Mandatory (Yes or No)
Search By	Used to indicate whether you want to search for an audit event using the audit event or entity details. The valid values are: <ul style="list-style-type: none"> <li>• Audit Event Details</li> <li>• Entity Details</li> </ul> <div style="border: 1px solid black; padding: 2px; margin-top: 5px;"> <b>Note:</b> By default, the <b>Audit Event Details</b> option is selected.         </div>	Yes
Audit Event ID	Used to search for a particular audit event. <div style="border: 1px solid black; padding: 2px; margin-top: 5px;"> <b>Note:</b> This field appears only when the <b>Audit Event Details</b> option is selected from the <b>Search By</b> list.         </div>	No
Created From	Used to search audit events which are created from a particular date onwards.	No



Field Name	Field Description	Mandatory (Yes or No)
Status	Used to search audit events with a particular status. The valid values are: <ul style="list-style-type: none"> <li>• Canceled</li> <li>• Complete</li> <li>• Error</li> <li>• Pending</li> </ul> <div style="border: 1px solid black; padding: 5px; margin-top: 10px;"> <b>Note:</b> This field appears only when the <b>Audit Event Details</b> option is selected from the <b>Search By</b> list. </div>	No
Created To	Used to search audit events which are created till a particular date.	No
Audit Action	Used to search audit events which are created while adding, updating, or deleting an entity. The valid values are: <ul style="list-style-type: none"> <li>• Add Row</li> <li>• Change Row</li> <li>• Delete Row</li> </ul> <div style="border: 1px solid black; padding: 5px; margin-top: 10px;"> <b>Note:</b> This field appears only when the <b>Audit Event Details</b> option is selected from the <b>Search By</b> list. </div>	No
Entity Business Object	Used to search audit events which are created for a particular entity business object. <div style="border: 1px solid black; padding: 5px; margin-top: 10px;"> <b>Note:</b>  The list includes only those business objects where the <b>Eligible for Audit Event</b> option type is set to <b>Y</b>.   This field appears only when the <b>Entity Details</b> option is selected from the <b>Search By</b> list. </div>	No

**Note:** You must specify at least one search criterion while searching for an audit event.

- **Search Results** - On clicking the **Search** button, the search results appear based on the specified search criteria. The **Search Results** section contains the following columns:

Column Name	Column Description
Creation Date Time	Displays the date and time when the audit event is created.
Audit Event Information	Displays information about the audit event. <div style="border: 1px solid black; padding: 5px; margin-top: 10px;"> <b>Note:</b> It has a link. On clicking the link, the <b>Audit Event</b> screen appears where you can view the details of the respective audit event. </div>

Column Name	Column Description
Status	Indicates the status of the audit event. The valid values are: <ul style="list-style-type: none"> <li>• Canceled</li> <li>• Complete</li> <li>• Error</li> <li>• Pending</li> </ul>
Audit Action	Indicates the action due to which the audit event is created for the entity. The valid values are: <ul style="list-style-type: none"> <li>• Add Row</li> <li>• Change Row</li> <li>• Delete Row</li> </ul>
Maintenance Object	Indicates the maintenance object of the entity business object for which the audit event is created. <div style="border: 1px solid black; padding: 5px; margin-top: 10px;"> <p><b>Note:</b> This column appears only when the <b>Entity Details</b> option is selected from the <b>Search By</b> list.</p> </div>

**Note:** Pagination is used to display limited number of records in the **Search Results** section. You can use the navigation links, such as **Previous** and **Next** to navigate between pages.

### Related Topics

For more information on...	See...
How to search for an audit event	<a href="#">Searching for an Audit Event</a> on page 2874
How to view the details of an audit event	<a href="#">Viewing the Audit Event Details</a> on page 2875

## Searching for an Audit Event

### Prerequisites

To search for an audit event, you should have:

- Entity business objects defined in the application
- The **Eligible for Audit Event** option type of the entity business object set to **Y**

**Note:** The **Eligible for Audit Event** option type is available for the entity business object only when the **Valid BO Option Type** option type of the respective maintenance object is set to **CIAT**.

### Procedure

To search for an audit event:

1. Click the **Menu** link in the **Application** toolbar.  
A list appears.
2. From the **Main** menu, select **Financial** and then click **Audit Event**.  
The **Audit Event** screen appears.
3. Enter the search criteria in the **Search Audit Event** zone.

**Note:** ORMB search engine supports wildcard search, where you can substitute the percentage (%) symbol as a stand in for any word or letter in a search criteria. You can use the ‘%’ wildcard character in all input fields except the date and ID fields. The ‘%’ wildcard character is suffixed automatically at the end of the partial search criteria. Therefore, you may or may not specify the wildcard character at the end of the partial search criteria. However, you have to prefix the wildcard character manually wherever required.

#### 4. Click **Search**.

A list of audit events that meet the search criteria appears in the **Search Results** section.

#### Related Topics

For more information on...	See...
<b>Audit Event</b> screen	<a href="#">Audit Event (Used for Searching)</a> on page 2872
<b>Search Audit Event</b> zone	<a href="#">Search Audit Event</a> on page 2872

## Viewing the Audit Event Details

#### Procedure

To view the details of an audit event:

1. Search for the audit event in the **Audit Event** screen.
2. In the **Search Results** section, click the link in the **Audit Event Information** column corresponding to the audit event whose details you want to view.

The **Audit Event** screen appears.

3. Ensure that the **Main** tab is selected.
4. View the details of the audit event in the **Audit Event** zone.

#### Related Topics

For more information on...	See...
How to search for an audit event	<a href="#">Searching for an Audit Event</a> on page 2874
<b>Audit Event</b> screen	<a href="#">Audit Event (Used for Viewing)</a> on page 2875
<b>Audit Event</b> zone	<a href="#">Audit Event</a> on page 2876

## Audit Event (Used for Viewing)

The **Audit Event** screen allows you to view the details of an audit event. In addition, it allows you to cancel an audit event which is in the **Error** status. It contains the following tabs:

- [Audit Event - Main](#) on page 2876
- [Audit Event - Log](#) on page 2877

#### Related Topics

For more information on...	See...
How to view the details of an audit event	<a href="#">Viewing the Audit Event Details</a> on page 2875

<b>For more information on...</b>	<b>See...</b>
How to cancel an audit event	<a href="#">Canceling an Audit Event</a> on page 2878

## Audit Event - Main

The **Main** tab displays information about the audit event. It contains the following zone:

- [Audit Event](#) on page 2876

### Audit Event

The **Audit Event** zone displays the details of the audit event. It contains the following sections:

- **Main** - Displays basic information about the audit event. It contains the following fields:

Field Name	Field Description
Audit Event Information	Displays information about the audit event.
Audit Event Type	Indicates the audit event type using which the audit event is created.  <b>Note:</b> It has a link. On clicking the link, the <b>Audit Event Type</b> screen appears where you can view the details of the respective audit event type.
Status	Indicates the status of the audit event. The valid values are: <ul style="list-style-type: none"> <li>• Canceled</li> <li>• Complete</li> <li>• Error</li> <li>• Pending</li> </ul>
Effective Date	Displays the effective date which is stamped corresponding to the audit event in the <b>C1_AUDIT_EVENT</b> table.  <b>Note:</b> If the entity has a start date, then the effective date is set to the entity's start date. But, if the entity does not have a start date, then the effective date is set to the system date.
Audit Action	Indicates the action due to which the audit event is created for the entity. The valid values are: <ul style="list-style-type: none"> <li>• Add Row</li> <li>• Change Row</li> <li>• Delete Row</li> </ul>
Maintenance Object	Indicates the maintenance object of the entity business object for which the audit event is created.  <b>Note:</b> It has a link. On clicking the link, the <b>Maintenance Object</b> screen appears where you can view the details of the respective maintenance object.

- **Characteristics** - Lists the characteristics defined for the audit event. It contains the following columns:

Column Name	Column Description
Characteristic Type	Indicates the characteristic type.

Column Name	Column Description
Characteristic Value	Displays the value of the characteristic type.

- **Record Actions** - This section contains the following button:

Button Name	Button Description
Cancel	Used to cancel the audit event.  <b>Note:</b> The <b>Cancel</b> button appears only when the audit event is in the <b>Error</b> status.

- **Record Information** - This section contains the following fields:

Field Name	Field Description
Business Object	Indicates the business object using which the audit event is created. In addition, a context menu appears corresponding to this field which helps in navigating to other screens in the application.  <b>Note:</b> It has a link. On clicking the link, the <b>Business Object</b> screen appears where you can view the details of the respective business object.
Status Date/Time	Displays the date and time when the audit event status is updated.
Create Date/Time	Displays the date and time when the audit event is created.

### **Related Topics**

For more information on...	See...
How to cancel an audit event	<a href="#">Canceling an Audit Event</a> on page 2878

## **Audit Event - Log**

The **Log** tab contains the following zone:

- [Audit Event Log](#) on page 2877

### **Audit Event Log**

The **Audit Event Log** zone lists the complete trail of actions performed on the audit event. It contains the following columns:

Column Name	Column Description
Creation Date Time	Displays the date and time when the action was performed on the audit event.
Details	Displays the details about the action performed on the audit event.
User	Indicates the user who has performed the action on the audit event.
Log type	Indicates the type of the log.
Related Object	Indicates the object or entity which is created when the action is performed on the audit event.  <b>Note:</b> At present, no data appears in this column. The implementation team can build the custom logic to meet the business requirements.

Column Name	Column Description
Status Reason	Indicates the reason why the status of the audit event is changed.  <b>Note:</b> At present, no data appears in this column. The implementation team can build the custom logic to meet the business requirements.

### Related Topics

For more information on...	See...
How to view the log of an audit event	<a href="#">Viewing the Log of an Audit Event</a> on page 2879

## Canceling an Audit Event

There might be situations when an erroneous audit event is created in the system. In such case, the system provides you with an ability to cancel such audit events. However, note that you can cancel an audit event only when the audit event is in the **Error** status.

### Prerequisites

To cancel an audit event, you should have:

- Cancel reasons defined in the application

**Note:** While cancelling an audit event, you need to specify the reason why you want to cancel the audit event. You can select the appropriate cancel reason only when you have defined the reasons for the **Canceled** status of the **C1-AuditEvent** business object in the **Status Reason** screen.

### Procedure

To cancel an audit event:

1. Search for the audit event in the **Audit Event** screen.
2. In the **Search Results** section, click the link in the **Audit Event Information** column corresponding to the audit event which you want to cancel.

The **Audit Event** screen appears.

3. Ensure that the **Main** tab is selected.
4. Click the **Cancel** button in the **Audit Event** zone.

The **Status Reason** window appears. It contains the following field:

Field Name	Field Description	Mandatory (Yes or No)
Status Reason	Used to indicate the reason why you want to cancel the audit event.	Yes

**Note:** The **Cancel** button appears only when the audit event is in the **Error** status.

5. Select the cancel reason from the **Status Reason** list.
6. Click **Save**.

The status of the audit event is changed to **Canceled**.

### Related Topics

For more information on...	See...
How to search for an audit event	<a href="#">Searching for an Audit Event</a> on page 2874
<b>Audit Event</b> screen	<a href="#">Audit Event (Used for Viewing)</a> on page 2875
<b>Audit Event</b> zone	<a href="#">Audit Event</a> on page 2876

## Viewing the Log of an Audit Event

### **Procedure**

To view the log of an audit event:

1. Search for the audit event in the **Audit Event** screen.
2. In the **Search Results** section, click the link in the **Audit Event Information** column corresponding to the audit event whose log you want to view.

The **Audit Event** screen appears.

3. Click the **Log** tab.

The **Log** tab appears.

4. View the complete trail of actions performed on the audit event in the **Audit Event Log** zone.

### **Related Topics**

For more information on...	See...
How to search for an audit event	<a href="#">Searching for an Audit Event</a> on page 2874
<b>Audit Event</b> screen	<a href="#">Audit Event (Used for Viewing)</a> on page 2875
<b>Audit Event Log</b> zone	<a href="#">Audit Event Log</a> on page 2877





---

# Appendix

# A

---

## Most Commonly Used Tasks

---

**Topics:**

- [Changing the Layout](#)

This section lists some of the common tasks that are performed while using various functionality in the application.

## Changing the Layout

---

You can change the layout of the zone by:

- [Removing a Column from the Zone](#) on page 2882
- [Adding a Column to the Zone](#) on page 2882
- [Rearranging Columns in the Zone](#) on page 2882

### Adding a Column to the Zone

Once you have removed the columns from the zone, you can add them back to the zone. To add a column to the zone:

1. Click the **Column Configuration**  icon in the upper right corner of the zone.

A panel appears at the bottom of the zone with a list of column names.

**Note:** The column names with the white background in the panel are currently not displayed in the zone.

2. Drag and drop the column name from the panel to the location where you want to add the column in the zone.  
The white background of the column name in the panel changes to the grey background indicating that the column is currently displayed in the zone.
3. If you want to add another column name from the panel to the zone, repeat the second step. Click the **Refresh** button, data will be displayed to the columns added in the zone.

#### Related Topics

For more information on...	See...
How to change the layout of the zone	<a href="#">Changing the Layout</a> on page 2882

### Rearranging Columns in the Zone

You can change the order in which the columns are displayed in the zone. To change the position of a column in the zone:

1. Click the column name whose position you want to change in the zone.
2. Drag and drop the column name between the columns where you want to place the selected column.

The position of the column changes in the zone.

#### Related Topics

For more information on...	See...
How to change the layout of the zone	<a href="#">Changing the Layout</a> on page 2882

### Removing a Column from the Zone

To remove a column from the zone:

Click the **Delete**  icon corresponding to the column name that you want to remove from the zone.

The column is removed from the zone and is currently displayed with white background in the panel.

**Note:** Alternatively you can remove the column from the zone by clicking the Delete (🗑️) icon corresponding to the column name in the panel.

### **Related Topics**

<b>For more information on...</b>	<b>See...</b>
How to change the layout of the zone	<a href="#">Changing the Layout</a> on page 2882



---

# Appendix

# B

---

## Administration

---

**Topics:**

- [UI Maps](#)
- [Feature Configurations](#)

This section lists some of the administrative tasks.

## UI Maps

---

This section explains how to create the UI maps for viewing and modifying data of the business objects within the approval workflow group.

### Creating Display UI Map for an Approval Workflow Group

The system provides you with the ability to automatically generate a Display UI map, and associate it with the approval workflow group. Alternatively, you can create a Display UI map manually, and attach it to the approval workflow group.

#### **Procedure**

To create a Display UI map manually:

1. Click the **Admin** link in the **Application** toolbar.  
A list appears.
2. From the **Admin** menu, select **U** and then click **UI Map**.  
A sub-menu appears.

3. Click the **Search** option from the **UI Map** sub-menu.  
The **UI Map** screen appears.

4. In the **Main** tab, enter the name and description of the Display UI map.

**Note:** The system uses the CM\_<Approval Workflow Group Code>\_AppTxn\_Display naming convention while automatically generating a Display UI map. Therefore, do not use this naming convention while creating a Display UI map manually.

5. Select **Complete HTML Document** from the **UI Map Type** list.
6. Click the **Schema** tab.  
The **Schema** tab appears.
7. Add the following schema in the **Scheme Editor** zone:

```
<schema>
  <<Business Object Name> type="group">
    <includeBO name="<Business Object Name>" />
  </<Business Object Name>>
</schema>
```

In the above schema, you must replace <Business Object Name> with the name of the business object. For example, if you want to create a Display UI map for account, you must use the following schema:

```
<schema>
  <account type="group">
    <includeBO name="Account" />
  </account>
</schema>
```

8. Click the **Save** link in the **Actions/Navigation** area.  
The **Display Only** and **Input Map** buttons are enabled on the dashboard.
9. Click the **Display Only** button.  
The HTML code is generated in the **HTML Editor** zone.
10. Click the **Save** link in the **Actions/Navigation** area.  
The changes are saved.

**Related Topics**

For more information on...	See...
How to define an approval workflow group	<a href="#">Defining an Approval Workflow Group</a> on page 710
How to edit an approval workflow group	<a href="#">Editing an Approval Workflow Group</a> on page 720

**Creating Input UI Map for an Approval Workflow Group**

The system provides you with the ability to automatically generate an Input UI map, and associate it with the approval workflow group. Alternatively, you can create an Input UI map manually, and attach it to the approval workflow group.

**Procedure**

To create an Input UI map manually:

1. Click the **Admin** link in the **Application** toolbar.  
A list appears.
2. From the **Admin** menu, select **U** and then click **UI Map**.  
A sub-menu appears.
3. Click the **Search** option from the **UI Map** sub-menu.  
The **UI Map** screen appears.
4. In the **Main** tab, enter the name and description of the Input UI map.

**Note:** The system uses the CM\_<Approval Workflow Group Code>\_AppTxn\_Input naming convention while automatically generating an Input UI map. Therefore, do not use this naming convention while creating an Input UI map manually.

5. Select **Complete HTML Document** from the **UI Map Type** list.
6. Click the **Schema** tab.  
The **Schema** tab appears.
7. Add the following schema in the **Scheme Editor** zone:

```
<schema>
  <approvalTransactionId/>
  <action/>
  <<Business Object Name> type="group">
    <includeBO name="<Business Object Name>" />
  </<Business Object Name>>
</schema>
```

In the above schema, you must replace <Business Object Name> with the name of the business object. For example, if you want to create an Input UI map for account, you must use the following schema:

```
<schema>
  <approvalTransactionId/>
  <action/>
  <account type="group">
    <includeBO name="Account" />
  </account>
</schema>
```

The `<approvalTransactionId/>` tag is used in the schema to retrieve the approval transaction ID of the respective business object. The `<action/>` tag is used in the schema to retrieve the action performed by the submitter.

- Click the **Save** link in the **Actions/Navigation** area.

The **Display Only** and **Input Map** buttons are enabled on the dashboard.

- Click the **Input Map** button.

The HTML code is generated in the **HTML Editor** zone.

- Add the following tag in the head tag:

```
<script language="javascript" type="text/javascript" src="code/
approvalWorkflow.js"></script>
```

- Add the text highlighted in bold within the tag as shown below:

```
<td>
<input onClick="performAction('<Approval Workflow Group Code>');"
oraMdLabel="SAVE_BTN_LBL" class="oraButton" type="button">
<input onClick="oraSubmitMap('CANCEL', false);" oraMdLabel="CANCEL_LBL"
class="oraButton" type="button">
</td>
```

In the above HTML code, you must replace `<Approval Workflow Group Code>` with the code of the approval workflow group for which you are creating a UI map.

- Click the **Save** link in the **Actions/Navigation** area.

The changes are saved.

### **Related Topics**

For more information on...	See...
How to define an approval workflow group	<a href="#">Defining an Approval Workflow Group</a> on page 710
How to edit an approval workflow group	<a href="#">Editing an Approval Workflow Group</a> on page 720

## **Feature Configurations**

---

This section explains how to set various feature configurations which are required for implementing various features in the Banking module.

### **Setting the C1\_ACCTINFO Feature Configuration**

#### **Prerequisites**

To set the **C1\_ACCTINFO** feature configuration, you should have:

- Account Type characteristic type defined in the application (where the characteristic entity is set to Account)
- Invoice Group Account characteristic type defined in the application (where the characteristic entity is set to Account)

#### **Procedure**

To set the **C1\_ACCTINFO** feature configuration:

- Click the **Admin** link in the **Application** toolbar.



A list appears.

- From the **Admin** menu, select **F** and then click **Feature Configuration**.

A sub-menu appears.

- Click the **Search** option from the **Feature Configuration** sub-menu.

The **Feature Configuration Search** window appears.

- Enter **C1\_ACCTINFO** in the **Feature Name** field.

- Click the **Search** button corresponding to the **Feature Name** field.

The **Feature Configuration** screen appears. It contains the following option types:

Option Type	Description	Mandatory (Yes or No)
Account Type	Used to specify the characteristic type. This characteristic type is used to define the type of account in the <b>Account</b> screen.  <b>Note:</b> By default, the <b>C1_F_ATY</b> characteristic type is specified. If you want to use account types other than the ones defined in the <b>C1_F_ATY</b> characteristic type, you need to create a new predefined characteristic type and add the required account types as its characteristic values. Then, specify the newly created characteristic type as the value for this option type.	Yes
Invoice Group Account	Used to specify the characteristic type. This characteristic type is used to indicate whether the account is a master or member account in the <b>Account</b> screen.  <b>Note:</b> By default, the <b>C1_F_IGA</b> characteristic type is specified. If you want to use any other characteristic type other than <b>C1_F_IGA</b> , you need to create a new predefined characteristic type and add two characteristic values — Y and N. Then, specify the newly created characteristic type as the value for this option type.	Yes

- Enter the values for the required option types in the **Feature Configuration** screen.

- Click the **Save** button in the **Page Title** area.

The changes made to the feature configuration are saved.

### **Related Topics**

For more information on...	See...
Invoicing Group	<a href="#">Invoicing Group</a>

## **Setting the C1-ASOBLNG Feature Configuration**

The **C1-ASOBLNG** feature configuration enables the system to determine the following:

- Whether the approval transaction should be created while defining, editing, or deleting a self-funded pricing rule
- Various parameters, characteristic types, and extendable lookup business objects which should be used while creating or editing the self-funded or fully-insured pricing rules
- Person relationship type using which the bill group should be related to the parent customer
- Policy person roles using which the parent customer and bill groups should be associated with the self-funded or fully-insured group policies
- Status to which a policy should be transitioned on terminating or reinstating the policy
- Status to which a membership and member person should be transitioned on inactivating the membership and member person, respectively

### **Prerequisites**

To set the **C1-ASOBLLNG** feature configuration, you should have:

- Required policy person roles and person relationship types defined in the application
- Approval workflow settings configured for the **C1PRCANC**, **C1PRCASL**, **C1PRCRLCLM**, **C1PRCDA**, **C1PRFLTFEE**, **C1PRCLVLFN**, **C1PRETCLM**, **C1PRRETENR**, and **C1PRCSSL** approval workflow groups
- Required characteristic types defined in the application
- Values defined for the **C1-ExtLookClaimTemplate**, **C1-ExtLookPricingRuleLineItem**, and **C1-ExtLookRetTypeRateOpt** extendable lookups
- Predefined values defined for the **C1INVTYP** characteristic type
- Required SQIs defined in the application
- Pricing arrangement parameter defined in the application (where the value type is set to **Adhoc**, source entity is set to **Transaction**, and the parameter usage is set to **Price Item**)
- Billable charge line type parameter defined in the application (where the value type is set to **Adhoc**, source entity is set to **Transaction**, and the parameter usage is set to **Price Item**)
- Pricing group rule parameter defined in the application (where the value type is set to **Adhoc**, source entity is set to **Transaction**, and the parameter usage is set to **Price Item**)

### **Procedure**

To set the **C1-ASOBLLNG** feature configuration:

1. Click the **Admin** link in the **Application** toolbar.  
A list appears.
2. From the **Admin** menu, select **F** and then click **Feature Configuration**.  
A sub-menu appears.
3. Click the **Search** option from the **Feature Configuration** sub-menu.  
The **Feature Configuration Search** window appears.
4. Enter **C1-ASOBLLNG** in the **Feature Name** field.
5. Click the **Search** button corresponding to the **Feature Name** field.  
The **Feature Configuration** screen appears. It contains the following option types:

Option Type	Description	Mandatory (Yes or No)
Age Based Parameter	<p>Used to specify the parameter using which you want to define the lower age limit and upper age limit pricing eligibility criteria in an age based pricing.</p> <p><b>Note:</b> The <b>AGEBASED</b> parameter is shipped with the product. By default, the value is set to <b>AGEBASED</b>. You can change the value, if required. However, note that you must specify an adhoc parameter where source entity is set to <b>Algorithm</b>, source type code is set to <b>Calculate membership person's age</b>, and the parameter usage is set to <b>Pricing Eligibility Criteria</b>.</p>	<p>Yes (Conditional)</p> <p><b>Note:</b> This data is required while defining an age based pricing rule.</p>
Approval Workflow Group for Ancillary	<p>Used to specify the approval workflow group for an ancillary pricing rule. It helps the system to determine whether the approval transaction should be created while defining, editing, or deleting an ancillary pricing rule.</p> <p><b>Note:</b> The <b>C1PRCANC</b> approval workflow group for an ancillary pricing rule is shipped with the product. By default, the value is set to <b>C1PRCANC</b>. You can change the value, if required.</p>	<p>Yes (Conditional)</p> <p><b>Note:</b> This data is required while enabling the approval workflow process for an ancillary pricing rule.</p>
Approval Workflow Group for ASL	<p>Used to specify the approval workflow group for an aggregate stop-loss pricing rule. It helps the system to determine whether the approval transaction should be created while defining, editing, or deleting an aggregate stop-loss pricing rule.</p> <p><b>Note:</b> The <b>C1PRCASL</b> approval workflow group for an aggregate stop-loss pricing rule is shipped with the product. By default, the value is set to <b>C1PRCASL</b>. You can change the value, if required.</p>	<p>Yes (Conditional)</p> <p><b>Note:</b> This data is required while enabling the approval workflow process for an aggregate stop-loss pricing rule.</p>

Option Type	Description	Mandatory (Yes or No)
Approval Workflow Group for Claim	<p>Used to specify the approval workflow group for a claim pricing rule. It helps the system to determine whether the approval transaction should be created while defining, editing, or deleting a claim pricing rule.</p> <p><b>Note:</b> The <b>CIPRCRLCLM</b> approval workflow group for a claim pricing rule is shipped with the product. By default, the value is set to <b>CIPRCRLCLM</b>. You can change the value, if required.</p>	<p>Yes (Conditional)</p> <p><b>Note:</b> This data is required while enabling the approval workflow process for a claim pricing rule.</p>
Approval Workflow Group for Discount Arrangement	<p>Used to specify the approval workflow group for the discount share and discount guarantee pricing rules. It helps the system to determine whether the approval transaction should be created while defining, editing, or deleting the discount share and discount guarantee pricing rules.</p> <p><b>Note:</b> The <b>CIPRCDA</b> approval workflow group for the discount share and discount guarantee pricing rules is shipped with the product. By default, the value is set to <b>CIPRCDA</b>. You can change the value, if required.</p>	<p>Yes (Conditional)</p> <p><b>Note:</b> This data is required while enabling the approval workflow process for the discount share and discount guarantee pricing rules.</p>
Approval Workflow Group for Flat Fees	<p>Used to specify the approval workflow group for the one-time and recurring flat fees pricing rules. It helps the system to determine whether the approval transaction should be created while defining, editing, or deleting the one-time and recurring flat fees pricing rules.</p> <p><b>Note:</b> The <b>CIPRFLTFEE</b> approval workflow group for the one-time and recurring flat fees pricing rules is shipped with the product. By default, the value is set to <b>CIPRFLTFEE</b>. You can change the value, if required.</p>	<p>Yes (Conditional)</p> <p><b>Note:</b> This data is required while enabling the approval workflow process for the one-time and recurring flat fees pricing rules.</p>

Option Type	Description	Mandatory (Yes or No)
Approval Workflow Group for Level Funded	<p>Used to specify the approval workflow group for the enrollment based premium and flat rate based premium level funded pricing rules. It helps the system to determine whether the approval transaction should be created while defining, editing, or deleting the enrollment based premium and flat rate based premium level funded pricing rules.</p> <p><b>Note:</b> The <b>C1PRCLVLFN</b> approval workflow group for the enrollment based premium and flat rate based premium level funded pricing rules is shipped with the product. By default, the value is set to <b>C1PRCLVLFN</b>. You can change the value, if required.</p>	<p>Yes (Conditional)</p> <p><b>Note:</b> This data is required while enabling the approval workflow process for the enrollment based premium and flat rate based premium level funded pricing rules.</p>
Approval Workflow Group for Retention Type Claim Based	<p>Used to specify the approval workflow group for a retention type claim based pricing rule. It helps the system to determine whether the approval transaction should be created while defining, editing, or deleting a retention type claim based pricing rule.</p> <p><b>Note:</b> The <b>C1PRETCLM</b> approval workflow group for a retention type claim based pricing rule is shipped with the product. By default, the value is set to <b>C1PRETCLM</b>. You can change the value, if required.</p>	<p>Yes (Conditional)</p> <p><b>Note:</b> This data is required while enabling the approval workflow process for a retention type claim based pricing rule.</p>
Approval Workflow Group for Retention Type Enrollment Based	<p>Used to specify the approval workflow group for a retention type enrollment based pricing rule. It helps the system to determine whether the approval transaction should be created while defining, editing, or deleting a retention type enrollment based pricing rule.</p> <p><b>Note:</b> The <b>C1PRRETENR</b> approval workflow group for a retention type enrollment based pricing rule is shipped with the product. By default, the value is set to <b>C1PRRETENR</b>. You can change the value, if required.</p>	<p>Yes (Conditional)</p> <p><b>Note:</b> This data is required while enabling the approval workflow process for a retention type enrollment based pricing rule.</p>

Option Type	Description	Mandatory (Yes or No)
Approval Workflow Group for SSL	<p>Used to specify the approval workflow group for a specific stop-loss pricing rule. It helps the system to determine whether the approval transaction should be created while defining, editing, or deleting a specific stop-loss pricing rule.</p> <p><b>Note:</b> The <b>CIPRCSSL</b> approval workflow group for a specific stop-loss pricing rule is shipped with the product. By default, the value is set to <b>CIPRCSSL</b>. You can change the value, if required.</p>	<p>Yes (Conditional)</p> <p><b>Note:</b> This data is required while enabling the approval workflow process for a specific stop-loss pricing rule.</p>
Base Fee Price Component Sequence Characteristic	<p>Used to specify the characteristic type where you want to store the sequence number of the eligible base fee's price component. This characteristic is then passed to the rating engine for further processing.</p> <p><b>Note:</b> The <b>CIBSFESE</b> characteristic type is shipped with the product. By default, the value is set to <b>CIBSFESE</b>. You can change the value, if required. However, note that you must specify an adhoc characteristic type where the characteristic entity is set to <b>Rate Component</b>.</p>	<p>Yes (Conditional)</p> <p><b>Note:</b> This data is required while billing fully-insured health care plans.</p>
Bill Group Policy Person Role	<p>Used to specify the policy person role using which a bill group should be associated with a self-funded or fully-insured group policy when the policy information is given for the bill group in an inbound message.</p> <p><b>Note:</b> You must specify a policy person role which is already defined in the system.</p>	<p>Yes</p>
Billable Charge Line Type Parameter	<p>Used to specify the parameter in which you want to store the billable charge line type. This parameter can then be used while defining an ancillary pricing rule type.</p> <p><b>Note:</b> You must specify an adhoc parameter where the source entity is set to <b>Transaction</b> and the parameter usage is set to <b>Price Item</b>.</p>	<p>Yes (Conditional)</p> <p><b>Note:</b> This data is required while defining an ancillary pricing rule type.</p>

Option Type	Description	Mandatory (Yes or No)
Claim Template Extendable Lookup Business Object	<p>Used to specify the claim template extendable lookup business object. The system displays the values of the specified extendable lookup in the <b>Claim Template</b> list while defining or editing a claim pricing rule type.</p> <p><b>Note:</b> The <b>C1-ExtLookClaimTemplate</b> extendable lookup for claim template is shipped with the product. By default, the value is set to <b>C1-ExtLookClaimTemplate</b>. You can change the value, if required.</p>	Yes
Customer Registration ID Characteristic for Inbound Log	<p>Used to specify the characteristic type where you want to store the customer registration ID. This characteristic type is used while creating a log entry for a health care inbound message. The log entry then indicates the customer registration object which is created through the health care inbound message.</p> <p><b>Note:</b> The <b>C1CRLOG</b> characteristic type is shipped with the product. By default, the value is set to <b>C1CRLOG</b>. You can change the value, if required. However, note that you must specify a foreign key characteristic type where the characteristic entity is set to <b>Inbound Message Log</b>.</p>	Yes (Conditional)  <b>Note:</b> This data is required while creating a person, account, policy, and/or policy plan through a health care inbound message.
Default Flat Rate Option	<p>Used to specify the rate option which must be used by default when the rate option is not given and the modifier method is set to either <b>FLAT</b> or <b>NULL</b> in the pricing rule data of a health care inbound message.</p> <p><b>Note:</b> You must specify a rate option where the rate schedule is set to <b>HC_FRTSC</b>.</p>	Yes (Conditional)  <b>Note:</b> This data is required while creating an age based and tier based pricing.
Default Percentage Rate Option	<p>Used to specify the rate option which must be used by default when the rate option is not given and the modifier method is set to either <b>EXPT</b> or <b>INPT</b> in the pricing rule data of a health care inbound message.</p> <p><b>Note:</b> You must specify a rate option where the rate schedule is set to <b>HC_PRTSC</b>.</p>	Yes (Conditional)  <b>Note:</b> This data is required while creating an age based and tier based pricing.

Option Type	Description	Mandatory (Yes or No)
Invoice Type Characteristic Type	<p>Used to specify the characteristic type which indicates the type of account. This characteristic type is defined for the account. The system then uses this characteristic type to determine the account on which the claim, specific stop-loss credits, aggregate stop-loss credits, claim based fee, enrollment based fee, one-time flat fees, recurring flat fees, ancillary, discount, level funded, or membership billable charge should be created in the system. For more information, refer to <a href="#">Bill Group's Account</a> on page 55.</p> <div data-bbox="586 575 1122 898" style="border: 1px solid black; padding: 5px;"> <p><b>Note:</b></p> <p>The <b>CIINVTYP</b> characteristic type is shipped with the product.</p> <p>By default, the value is set to <b>CIINVTYP</b>. You can change the value, if required. However, note that you must specify a predefined characteristic type where the characteristic entity is set to <b>Account</b>.</p> </div>	Yes
Line Item Extendable Lookup Business Object	<p>Used to specify the line item extendable lookup business object. The system displays the values of the specified extendable lookup in the <b>Line Item</b> list while defining, editing, or copying a claim template.</p> <div data-bbox="586 1100 1122 1388" style="border: 1px solid black; padding: 5px;"> <p><b>Note:</b></p> <p>The <b>C1-ExtLookPricingRuleLineItem</b> extendable lookup for line item is shipped with the product.</p> <p>By default, the value is set to <b>C1-ExtLookPricingRuleLineItem</b>. You can change the value, if required.</p> </div>	Yes
Membership Characteristic ID for Billable Charge	<p>Used to specify the characteristic type where you want to store the membership ID. During the fully-insured billable charge creation process, this characteristic is stamped on a billable charge which indicates the membership for which the billable charge is created.</p> <div data-bbox="586 1629 1122 1738" style="border: 1px solid black; padding: 5px;"> <p><b>Note:</b> You must specify a foreign key characteristic type where the characteristic entity is set to <b>Billable Charge</b>.</p> </div>	<p>Yes (Conditional)</p> <div data-bbox="1143 1472 1468 1581" style="border: 1px solid black; padding: 5px;"> <p><b>Note:</b> This data is required while billing fully-insured health care plans.</p> </div>



Option Type	Description	Mandatory (Yes or No)
Membership Characteristic Inbound Log ID for	<p>Used to specify the characteristic type where you want to store the membership ID. This characteristic type is used while creating a log entry for a health care inbound message. The log entry then indicates the membership which is created through the health care inbound message.</p> <p><b>Note:</b> The <b>CIMBRLOG</b> characteristic type is shipped with the product. By default, the value is set to <b>CIMBRLOG</b>. You can change the value, if required. However, note that you must specify a foreign key characteristic type where the characteristic entity is set to <b>Inbound Message Log</b>.</p>	Yes (Conditional)  <p><b>Note:</b> This data is required while creating a membership through a health care inbound message.</p>
Membership Status Inactive	<p>Used to specify the status to which the membership must be transitioned when the main subscriber is inactivated.</p> <p><b>Note:</b> You must specify a status which is defined in the lifecycle of the <b>C1-Membership</b> business object.</p>	Yes (Conditional)  <p><b>Note:</b> This data is required while inactivating a membership.</p>
Membership Inactive Status Person	<p>Used to specify the status to which the member persons must be transitioned when the membership is inactivated.</p> <p><b>Note:</b> You must specify a status which is defined in the <b>MEMBER_PER_STATUS_FLG</b> lookup field.</p>	Yes (Conditional)  <p><b>Note:</b> This data is required while inactivating a membership.</p>
Override Applicability Characteristic Type Proration	<p>Used to specify the characteristic type which indicates whether the proration rule should be overridden for a member person. At present, the override proration feature is used for a new born when the gift days are offered to a new born. This characteristic type can be defined for the membership, policy plan, policy, and state.</p> <p><b>Note:</b> You must specify a characteristic type where the characteristic entity is set to <b>Membership, Policy Plan, Policy, and State</b>. Here, the predefined values for the characteristic type can be <b>Y</b> and <b>N</b>.</p>	Yes (Conditional)  <p><b>Note:</b> This data is required when you want to override the proration rule.</p>

Option Type	Description	Mandatory (Yes or No)
Override Proration Effective Date Characteristic Type	<p>Used to specify the characteristic type where you want to store the date from when the premium should be calculated for the new born. This characteristic is used during the bill segment generation to determine the bill period in which the date falls. The system then accordingly prorates the premium amount for the new born.</p> <p><b>Note:</b> You must specify a characteristic type where the characteristic entity is set to <b>Membership Person</b>.</p>	<p>Yes (Conditional)</p> <p><b>Note:</b> This data is required when you want to override the proration rule.</p>
Override Proration Rule Characteristic Type	<p>Used to specify the characteristic type where you want to store the override SQ rule for a new born. This characteristic type can be defined for the membership, policy plan, policy, and state. If this characteristic is not defined at any level, the system uses the SQ rule of the rate schedule attached to the active contract to prorate the premium amount of a new born child.</p> <p><b>Note:</b> You must specify a characteristic type where the characteristic entity is set to <b>Membership, Policy Plan, Policy, and State</b>.</p>	<p>Yes (Conditional)</p> <p><b>Note:</b> This data is required when you want to override the proration rule.</p>
Parent Customer Policy Person Role	<p>Used to specify the policy person role using which the parent customer should be associated with a self-funded or fully-insured group policy when the policy information is given for the bill group or parent customer in an inbound message.</p> <p><b>Note:</b> You must specify a policy person role which is already defined in the system.</p>	<p>Yes</p>
Person ID Characteristic for Inbound Log	<p>Used to specify the characteristic type where you want to store the person ID. This characteristic type is used while creating a log entry for a health care inbound message. The log entry then indicates the person whose record is created through the health care inbound message.</p> <p><b>Note:</b></p> <p>The <b>CIPERLOG</b> characteristic type is shipped with the product.</p> <p>By default, the value is set to <b>CIPERLOG</b>. You can change the value, if required. However, note that you must specify a foreign key characteristic type where the characteristic entity is set to <b>Inbound Message Log</b>.</p>	<p>Yes (Conditional)</p> <p><b>Note:</b> This data is required while creating a person through a health care inbound message.</p>

Option Type	Description	Mandatory (Yes or No)
Person Relationship Type	<p>Used to indicate how a bill group should be related to a parent customer. The system uses the person relationship type while:</p> <ul style="list-style-type: none"> <li>• Creating a bill group for a parent customer through an inbound message</li> <li>• Viewing the 360° information of a parent customer</li> </ul> <p><b>Note:</b> You must specify a person relationship type which is already defined in the system.</p>	Yes
Policy Status      Reinstatement	<p>Used to specify the status to which the policy must be transitioned when it is reinstated.</p> <p><b>Note:</b> You must specify a status which is defined in the lifecycle of the <b>C1-POLICY</b> business object.</p>	Yes (Conditional)  <b>Note:</b> This data is required while reinstating a fully-insured group policy.
Policy Status      Termination	<p>Used to specify the status to which the policy must be transitioned when it is terminated.</p> <p><b>Note:</b> You must specify a status which is defined in the lifecycle of the <b>C1-POLICY</b> business object.</p>	Yes (Conditional)  <b>Note:</b> This data is required while terminating a fully-insured group policy.
Pricing Parameter      Arrangement	<p>Used to specify the parameter in which you want to store the pricing arrangement. This parameter can then be used while defining an ancillary pricing rule type.</p> <p><b>Note:</b> You must specify an adhoc parameter where the source entity is set to <b>Transaction</b> and the parameter usage is set to <b>Price Item</b>.</p>	Yes (Conditional)  <b>Note:</b> This data is required while defining an ancillary pricing rule type.
Pricing Parameter      Group Rule	<p>Used to specify the parameter in which you want to store the pricing group rule. The system stamps this parameter on the price assignment which is created through a pricing rule using a pricing group. It indicates that the price assignment is created using the respective rule in the pricing group.</p> <p><b>Note:</b> You must specify an adhoc parameter where the source entity is set to <b>Transaction</b> and the parameter usage is set to <b>Price Item</b>.</p>	Yes (Conditional)  <b>Note:</b> This data is required while defining a claim, specific stop-loss, aggregate stop-loss, retention type claim based, or retention type enrollment based pricing rule for a bill group using a pricing group.

Option Type	Description	Mandatory (Yes or No)
Pricing Rule ID Characteristic for Inbound Log	<p>Used to specify the characteristic type where you want to store the pricing rule ID. This characteristic type is used while creating a log entry for a health care inbound message. The log entry then indicates the pricing rule which is created through the health care inbound message.</p> <p><b>Note:</b> The <b>CIPRLOG</b> characteristic type is shipped with the product. By default, the value is set to <b>CIPRLOG</b>. You can change the value, if required. However, note that you must specify a foreign key characteristic type where the characteristic entity is set to <b>Inbound Message Log</b>.</p>	<p>Yes (Conditional)</p> <p><b>Note:</b> This data is required while creating a pricing rule through a health care inbound message.</p>
Pricing Rule Type Category Characteristic	<p>Used to specify the characteristic type which indicates the pricing rule type category. This characteristic type is defined for a billable charge line type. The system uses this characteristic to lists the billable charge line types which are valid while defining a pricing rule type or pricing rule of a particular category.</p> <p><b>Note:</b> The <b>CIPRTCAT</b> characteristic type is shipped with the product. By default, the value is set to <b>CIPRTCAT</b>. You can change the value, if required. However, note that you must specify a foreign key characteristic type where the characteristic entity is set to <b>Billable Charge Line Type</b>.</p>	<p>Yes</p>
Proration SQI	<p>Used to specify the SQI using which you want to create an SQI based billable charge for pre-calculated or calculated premium amount. If the SQ rule of the rate schedule attached to the active contract contains the specified SQI, the system prorates the SQI amount whenever required.</p> <p><b>Note:</b> You must specify an SQI which is already defined in the system.</p>	<p>Yes (Conditional)</p> <p><b>Note:</b> This data is required while billing fully-insured health care plans.</p>

Option Type	Description	Mandatory (Yes or No)
Rate Component Base Fee Characteristic	<p>Used to specify the characteristic type which indicates whether the rate component is a base fee rate component. This characteristic type is defined for the rate component.</p> <p><b>Note:</b> The <b>C1RCBFMA</b> characteristic type is shipped with the product. By default, the value is set to <b>C1RCBFMA</b>.</p>	Yes
Rate Option Extendable Lookup Business Object	<p>Used to specify the rate option extendable lookup business object. The system displays the values of the specified extendable lookup in the <b>Rate Option</b> list while defining, editing, or copying a pricing rule type.</p> <p><b>Note:</b> The <b>C1-ExtLookRetTypeRateOpt</b> extendable lookup for rate option is shipped with the product. By default, the value is set to <b>C1-ExtLookRetTypeRateOpt</b>. You can change the value, if required.</p>	Yes
State of Issue Characteristic Type	<p>Used to specify the characteristic type where you want to store the state for which the membership, policy plan, or policy is issued. This characteristic type can be defined for the membership, policy plan, or policy. This characteristic is used while identifying a list of eligible children in a membership for premium calculation.</p> <p><b>Note:</b> You must specify a characteristic type where the characteristic entity is set to <b>Membership, Policy Plan, and Policy</b>.</p>	Yes (Conditional)  <p><b>Note:</b> This data is required while identifying a list of eligible children for premium calculation.</p>

Option Type	Description	Mandatory (Yes or No)
To Do Role Characteristic Type	<p>Used to specify the characteristic type where you want to store the To Do role. This characteristic type is defined for the parent customer. The system uses this characteristic to determine the users to whom the To Dos created using the <b>C1-REPC1</b>, <b>C1-REPC2</b>, and <b>C1-FIBCR</b> To Do types should be assigned.</p> <p><b>Note:</b> A To Do is created using the <b>C1-REPC1</b> To Do type when an error occurs while creating a repricing request. A To Do is created using the <b>C1-REPC2</b> To Do type when an error occurs while calculating membership premium. And, a To Do is created using the <b>C1-FIBCR</b> To Do type when an error occurs while creating a billable charge for a membership. You must specify an adhoc characteristic type where the characteristic entity is set to <b>Person</b>.</p>	<p>Yes (Conditional)</p> <p><b>Note:</b> This data is required while billing fully-insured health care plans.</p>

6. Enter the values for the required option types in the **Feature Configuration** screen.

7. Click the **Save** button in the **Page Title** area.

The changes made to the feature configuration are saved.

#### Related Topics

For more information on...	See...
<b>Customer 360° Information</b> screen	<a href="#">Customer 360° Information</a> on page 196
ASO Customer Inbound Message	<a href="#">ASO Customer Inbound Message</a> on page 1826
Health Care Inbound Message	<a href="#">Health Care Inbound Message</a> on page 1863

## Setting the C1\_AXENTITY Feature Configuration

### Procedure

To set the **C1\_AXENTITY** feature configuration:

- Click the **Admin** link in the **Application** toolbar.  
A list appears.
- From the **Admin** menu, select **F** and then click **Feature Configuration**.  
A sub-menu appears.
- Click the **Search** option from the **Feature Configuration** sub-menu.  
The **Feature Configuration Search** window appears.
- Enter **C1\_AXENTITY** in the **Feature Name** field.
- Click the **Search** button corresponding to the **Feature Name** field.

The **Feature Configuration** screen appears. It contains the following option types:

Option Type	Description	Mandatory (Yes or No)
Approval Transaction Compare New or Missing Entry Color	Used to indicate the color in which the new additions must be highlighted. This helps in comparing the existing and new data while approving, rejecting, or cancelling approval workflow requests. You must specify hexadecimal value in this option type.	Yes
Approval Transaction Compare Value Changed Color	Used to indicate the color in which the existing data modifications must be highlighted. This helps in comparing the existing and new data while approving, rejecting, or cancelling approval workflow requests. You must specify hexadecimal value in this option type.	Yes
Approval Transaction Entity Access Algorithms	Used to specify the algorithm which controls access to the existing and new maintenance objects based on the access group and division. By default, the C1-APPTXN algorithm is specified. If you create new maintenance objects and want the access control for these new maintenance objects to be based on the access group and division, you have to create a custom algorithm and then attach it to this option type. In such case, you would define this option type twice — one with the default algorithm (that is, C1-APPTXN) and another with the custom algorithm.	Yes
Approval Transaction Fields to be Disabled in Input UI Maps	Used to indicate the fields that you want to disable whenever the input UI maps are regenerated.	Yes
Approval Transaction Resolve To Do Type	Used to indicate the type of To Do that must be created when an approver at any level in the hierarchy rejects a request.	Yes
Display UI XSL	Used to indicate the XSL file that you want to use while regenerating the Display UI maps.	Yes
Input UI XSL	Used to indicate the XSL file that you want to use while regenerating the Input UI maps.	Yes

- Enter the values for the required option types in the **Feature Configuration** screen.
- Click the **Save** button in the **Page Title** area.

The changes made to the feature configuration are saved.

### **Related Topics**

For more information on...	See...
How to set the prerequisites to implement the approval workflow process	<a href="#">Prerequisites</a> on page 655
How to approve price assignment request of an account	<a href="#">Approving a Price Assignment for an Account</a> on page 675
How to approve price assignment request of a person	<a href="#">Approving a Price Assignment for a Person</a> on page 676

For more information on...	See...
How to approve price assignment request of a price list	<a href="#">Approving a Price Assignment for a Price List</a> on page 677
How to reject price assignment request of an account	<a href="#">Rejecting a Price Assignment for an Account</a> on page 678
How to reject price assignment request of a person	<a href="#">Rejecting a Price Assignment for a Person</a> on page 679
How to reject price assignment request of a price list	<a href="#">Rejecting a Price Assignment for a Price List</a> on page 681
How to cancel price assignment request of an account	<a href="#">Canceling a Price Assignment for an Account</a> on page 682
How to cancel price assignment request of a person	<a href="#">Canceling a Price Assignment for a Person</a> on page 683
How to cancel price assignment request of a price list	<a href="#">Canceling a Price Assignment for a Price List</a> on page 685

## Setting the C1-BILLADJSQ Feature Configuration

### Prerequisites

To set the **C1-BILLADJSQ** feature configuration, you should have:

- Service quantity identifiers (SQIs) defined in the application

### Procedure

To set the **C1-BILLADJSQ** feature configuration:

1. Click the **Admin** link in the **Application** toolbar.  
A list appears.
2. From the **Admin** menu, select **F** and then click **Feature Configuration**.  
A sub-menu appears.
3. Click the **Search** option from the **Feature Configuration** sub-menu.  
The **Feature Configuration Search** window appears.
4. Enter **C1-BILLADJSQ** in the **Feature Name** field.
5. Click the **Search** button corresponding to the **Feature Name** field.

The **Feature Configuration** screen appears. It contains the following option types:

Option Type	Description	Mandatory (Yes or No)
Billable Charge SQI	Used to specify the service quantity identifier (SQI) which you want to use while creating a billable charge for the state assessment fee.  <b>Note:</b> You must specify an SQI which is already defined in the system.	Yes (Conditional)  <b>Note:</b> This data is required when you want to create billable charges for the state assessment fee.



Option Type	Description	Mandatory (Yes or No)
Coverage End Date SQI	Used to specify the service quantity identifier (SQI) which you want use to derive the coverage end date from the account's last billed charge. The system uses the derived coverage end date in calculating the future retro adds (debits) for the respective account.  <b>Note:</b> You must specify an SQI which is already defined in the system.	Yes
Premium Amount SQI	Used to specify the service quantity identifier (SQI) based on which you want to calculate the catch up premium for each eligible billable charge. The value derived is finally used to calculate the future retro adds (debits) for the respective account.  <b>Note:</b> You must specify an SQI which is already defined in the system.  The future retro adds (debits) appears in the <b>Billing and Adjustment Summary</b> zone of the <b>Account</b> tab on the <b>Customer 360° Information</b> screen.	Yes

- Enter the values for the required option types in the **Feature Configuration** screen.
- Click the **Save** button in the **Page Title** area.

The changes made to the feature configuration are saved.

#### Related Topics

For more information on...	See...
<b>Billing and Adjustment Summary</b> zone	<a href="#">Billing and Adjustment Summary</a> on page 218

## Setting the C1-BILLCYCLE Feature Configuration

On executing the **Customer Inbound Message Periodic Monitor (C1-CUSIN)** batch, the system validates whether the bill cycle specified in the customer inbound message exists in the **C1-BILLCYCLE** feature configuration. Therefore, you need to ensure that the specified bill cycle exists in the **C1-BILLCYCLE** feature configuration before processing the customer inbound message.

#### Prerequisites

To set the **C1-BILLCYCLE** feature configuration, you should have:

- Values defined for the **C1BC\_OPT\_TYP\_FLG** lookup field

#### Procedure

To set the **C1-BILLCYCLE** feature configuration:

- Click the **Admin** link in the **Application** toolbar.

A list appears.

- From the **Admin** menu, select **F** and then click **Feature Configuration**.

A sub-menu appears.

- Click the **Search** option from the **Feature Configuration** sub-menu.

The **Feature Configuration Search** window appears.

- Enter **C1-BILLCYCLE** in the **Feature Name** field.

- Click the **Search** button corresponding to the **Feature Name** field.

The **Feature Configuration** screen appears. It contains the following option types:

Option Type	Description	Mandatory (Yes or No)
<Value from the <b>C1BC_OPT_TYP_FLG</b> lookup field>	Used to specify the bill cycle. <b>Note:</b> You must specify a bill cycle which is already defined in the system.	Yes

- Enter the values for the required option types in the **Feature Configuration** screen.

- Click the **Save** button in the **Page Title** area.

The changes made to the feature configuration are saved.

### **Related Topics**

For more information on...	See...
Customer Inbound Message XML Format	<a href="#">Customer Inbound Message XML Format</a> on page 1773

## **Setting the C1\_CMO Feature Configuration**

### **Prerequisites**

To set the **C1\_CMO** feature configuration, you should have:

- Contract types defined in the application

### **Procedure**

To set the **C1\_CMO** feature configuration:

- Click the **Admin** link in the **Application** toolbar.

A list appears.

- From the **Admin** menu, select **F** and then click **Feature Configuration**.

A sub-menu appears.

- Click the **Search** option from the **Feature Configuration** sub-menu.

The **Feature Configuration Search** window appears.

- Enter **C1\_CMO** in the **Feature Name** field.

- Click the **Search** button corresponding to the **Feature Name** field.

The **Feature Configuration** screen appears. It contains the following option types:

Option Type	Description	Mandatory (Yes or No)
Administrative Contract Type	Used to specify the contract type. The contracts of the specified contract type are then listed in the <b>Administrative Contracts</b> zone of the <b>Account</b> tab on the <b>Customer 360° Information</b> screen.	Yes
On Account Contract Type	Used to specify the contract type. The excess credit transactions on the contracts of the specified contract type are then listed in the <b>Billed Vs Paid</b> zone of the <b>Account</b> tab on the <b>Customer 360° Information</b> screen.	Yes

- Enter the values for the required option types in the **Feature Configuration** screen.
- Click the **Save** button in the **Page Title** area.

The changes made to the feature configuration are saved.

### Related Topics

For more information on...	See...
<b>Administrative Contracts</b> zone	<a href="#">Administrative Contracts</a> on page 216
<b>Billed Vs Paid</b> zone	<a href="#">Billed Vs Paid</a> on page 220

## Setting the C1\_DIVFUNCT Feature Configuration

### Procedure

To set the **C1\_DIVFUNCT** feature configuration:

- Click the **Admin** link in the **Application** toolbar.  
A list appears.
- From the **Admin** menu, select **F** and then click **Feature Configuration**.  
A sub-menu appears.
- Click the **Search** option from the **Feature Configuration** sub-menu.  
The **Feature Configuration Search** window appears.
- Enter **C1\_DIVFUNCT** in the **Feature Name** field.
- Click the **Search** button corresponding to the **Feature Name** field.

The **Feature Configuration** screen appears. It contains the following option types:

Option Type	Description	Mandatory (Yes or No)
Enforce division-specific validations	Used to indicate whether the division-specific validations must be triggered on the <b>Person</b> , <b>Account</b> and <b>Contract</b> screens. The valid values are: <ul style="list-style-type: none"> <li>• Y</li> <li>• N</li> </ul>	Yes

- Enter the values for the required option types in the **Feature Configuration** screen.
- Click the **Save** button in the **Page Title** area.

The changes made to the feature configuration are saved.

## Setting the C1\_EXCHRATE Feature Configuration

### **Procedure**

To set the **C1\_EXCHRATE** feature configuration:

- Click the **Admin** link in the **Application** toolbar.  
A list appears.
- From the **Admin** menu, select **F** and then click **Feature Configuration**.  
A sub-menu appears.
- Click the **Search** option from the **Feature Configuration** sub-menu.  
The **Feature Configuration Search** window appears.
- Enter **C1\_EXCHRATE** in the **Feature Name** field.
- Click the **Search** button corresponding to the **Feature Name** field.

The **Feature Configuration** screen appears. It contains the following option types:

Option Type	Description	Mandatory (Yes or No)
End Date Required for Division Override	Used to indicate whether the end date is mandatory for a division-specific exchange rate. The valid values are: <ul style="list-style-type: none"> <li>Y</li> <li>N</li> </ul> By default, the value of this option type is set to <b>N</b> .	Yes

- Enter the values for the required option types in the **Feature Configuration** screen.
- Click the **Save** button in the **Page Title** area.

The changes made to the feature configuration are saved.

### **Related Topics**

For more information on...	See...
How to define an exchange rate	<a href="#">Defining an Exchange Rate</a> on page 836
How to edit an exchange rate	<a href="#">Editing an Exchange Rate</a> on page 840

## Setting the C1\_EXP\_OVRD Feature Configuration

### **Procedure**

To set the **C1\_EXP\_OVRD** feature configuration:

1. Click the **Admin** link in the **Application** toolbar.  
A list appears.
2. From the **Admin** menu, select **F** and then click **Feature Configuration**.  
A sub-menu appears.
3. Click the **Search** option from the **Feature Configuration** sub-menu.  
The **Feature Configuration Search** window appears.
4. Enter **C1\_EXP\_OVRD** in the **Feature Name** field.
5. Click the **Search** button corresponding to the **Feature Name** field.

The **Feature Configuration** screen appears. It contains the following option types:

Option Type	Description	Mandatory (Yes or No)
Expire Override Switch	Used to indicate whether you want to automatically expire an agreed pricing when the agreed pricing of a person or an account without end date is overridden. The valid values are: <ul style="list-style-type: none"> <li>• Y</li> <li>• N</li> </ul>	Yes

6. Enter the values for the required option types in the **Feature Configuration** screen.
7. Click the **Save** button in the **Page Title** area.  
The changes made to the feature configuration are saved.

## Setting the C1\_FINTRANOP Feature Configuration

### Procedure

To set the **C1\_FINTRANOP** feature configuration:

1. Click the **Admin** link in the **Application** toolbar.  
A list appears.
2. From the **Admin** menu, select **F** and then click **Feature Configuration**.  
A sub-menu appears.
3. Click the **Search** option from the **Feature Configuration** sub-menu.  
The **Feature Configuration Search** window appears.
4. Enter **C1\_FINTRANOP** in the **Feature Name** field.
5. Click the **Search** button corresponding to the **Feature Name** field.

The **Feature Configuration** screen appears. It contains the following option types:

Option Type	Description	Mandatory (Yes or No)
Bill Segment Regeneration on Freeze	<p>Used to indicate whether you want to regenerate the bill segments before freezing them. The valid value is:</p> <ul style="list-style-type: none"> <li>• Y</li> </ul> <p>If you do not want to regenerate the bill segments before freezing them, you must leave this option type blank.</p> <div style="border: 1px solid black; padding: 5px;"> <p><b>Note:</b> If the <b>Freeze and Complete</b> check box is selected for the bill cycle and the <b>Bill Segment Regeneration on Freeze</b> option type is set to <b>Y</b>, then the bill segments are regenerated and the status of the bill segments is set to <b>Frozen</b>. However, if the <b>Freeze and Complete</b> check box is not selected for the bill cycle, then the bill segments are always regenerated irrespective of whether the <b>Bill Segment Regeneration on Freeze</b> option type is set to <b>Y</b> or not.</p> </div>	No
Billable Charges Date	<p>Used to indicate whether you want to consider the billable charges whose start or end date is earlier than or equal to the cut-off date. The valid values are:</p> <ul style="list-style-type: none"> <li>• <b>S</b> — Used when you want to consider the billable charges whose start date is earlier than or equal to the cut-off date.</li> <li>• <b>E</b> — Used when you want to consider the billable charges whose end date is earlier than or equal to the cut-off date.</li> </ul> <p>If you do not set the value of this option type, by default, the system considers the billable charges whose start date is earlier than or equal to the cut-off date.</p>	No

6. Enter the values for the required option types in the **Feature Configuration** screen.

7. Click the **Save** button in the **Page Title** area.

The changes made to the feature configuration are saved.

## Setting the C1\_FM Feature Configuration

### Procedure

To set the **C1\_FM** feature configuration:

1. Click the **Admin** link in the **Application** toolbar.

A list appears.

2. From the **Admin** menu, select **F** and then click **Feature Configuration**.

A sub-menu appears.

- Click the **Search** option from the **Feature Configuration** sub-menu.

The **Feature Configuration Search** window appears.

- Enter **C1\_FM** in the **Feature Name** field.

- Click the **Search** button corresponding to the **Feature Name** field.

The **Feature Configuration** screen appears. It contains the following option types:

Option Type	Description	Mandatory (Yes or No)
First Batch in Transaction Aggregation Cycle	Used to specify the first mandatory batch that you want to be executed in the transaction aggregation cycle.  <b>Note:</b> At present, the system does not support any value other than <b>C1-TXNIP</b> for this option type.	Yes
Last Batch in Transaction Aggregation Cycle	Used to specify the last mandatory batch that you want to be executed in the transaction aggregation cycle.  <b>Note:</b> At present, the system does not support any value other than <b>C1-TXNCU</b> for this option type.	Yes
Disaggregation - Price Assignment	Used to indicate whether the disaggregation request should be automatically created for a person or account when a price item is assigned to the person or account or the existing price item pricing assigned to the person or account is modified. The valid values are:  <ul style="list-style-type: none"> <li>• true</li> <li>• false</li> </ul> <b>Note:</b> You can use this feature only when an algorithm which is created using the <b>TXNDISAGGPRA</b> algorithm type is attached to the <b>Post-Processing</b> system event of the <b>C1_PRASGN_BO</b> business object.	No

Option Type	Description	Mandatory (Yes or No)
Allow Duplicate Summary ID	<p>Used to indicate whether the transaction legs can have duplicate summary ID while creating an aggregated billable charge using the <b>Service Quantity Calculation (C1-TXNSQ)</b> batch. The valid values are:</p> <ul style="list-style-type: none"> <li>• true</li> <li>• false</li> </ul> <div style="border: 1px solid black; padding: 5px; margin-top: 10px;"> <p><b>Note:</b></p> <p>If you set this option type to <b>false</b>, the system does not create the aggregated billable charge when one or more transaction legs have the same summary ID.</p> <p>If you do not specify the value for this option type, by default, the value is set to <b>false</b>.</p> </div>	No



Option Type	Description	Mandatory (Yes or No)
Parallel Query Degree	<p>Used to specify the degree of parallelism that you want to use while creating chunks (i.e. work units) in various Transaction Feed Management (TFM) batches. The valid values are:</p> <ul style="list-style-type: none"> <li>• 1</li> <li>• 2</li> <li>• 3</li> <li>• 4</li> <li>• 5</li> <li>• 6</li> <li>• 7</li> </ul> <div style="border: 1px solid black; padding: 5px; margin-top: 10px;"> <p><b>Note:</b></p> <p>With the parallel query feature, multiple threads on the database can work together simultaneously to process a single SQL statement which is used to create chunks. This helps to improve the batch performance.</p> <p>The system calculates the number of threads on the database that can be used to execute the SQL statement by setting 2 to the power of the specified parallel query degree. For example, if you set the parallel query degree to 4, the system uses 16 (i.e. 2<sup>4</sup>) threads on the database to create work units.</p> <p>You must set the parallel query degree depending on the infrastructure available on the site. If you do not specify the value for this option type, by default, the parallel query degree is set to 2.</p> </div>	No
Price Item Determination Batch Description	Used to specify the description for the batch which is used for validating the transaction and deriving the price item in the transaction aggregation cycle. For example, <b>Validate Transaction and Derive Price Item</b> . This description appears in the error message when the transaction aggregation batches are not executed in the specified sequence.	Yes

Option Type	Description	Mandatory (Yes or No)
Remove Duplicates from Accumulated Rule Output	<p>Used to indicate whether duplicate transaction legs must be created during the transaction aggregation cycle through the rule output accumulation process. The valid values are:</p> <ul style="list-style-type: none"> <li>• true</li> <li>• false</li> </ul> <p><b>Note:</b> If you do not specify the value for this option type, by default, the value is set to <b>false</b>.</p>	No
Rule Output Accumulation	<p>Used to indicate whether the system should accumulate the output parameters of all rules where the criteria returns <b>Rule Is True</b> irrespective of whether the rule true action is set to <b>Next Dependent</b>, <b>Next Rule by Priority</b>, or <b>Success</b> and then create transaction legs using the accumulated output parameters. The valid values are:</p> <ul style="list-style-type: none"> <li>• true</li> <li>• false</li> </ul> <p><b>Note:</b> If you do not specify the value for this option type, by default, the value is set to <b>false</b>.</p>	No
Show Default Values in Price Item Pricing	<p>Used to indicate whether the default values must appear in the <b>Ignore Transaction</b>, <b>Aggregate Transaction</b>, and <b>Aggregation Schedule</b> fields while defining the price item pricing. The valid values are:</p> <ul style="list-style-type: none"> <li>• Y</li> <li>• N</li> </ul>	Yes
Use Materialized Views	<p>Used to indicate whether the price item pricing information must be cached in the <b>CI_PRC_AGRD</b>, <b>CI_PRC_PL</b>, and <b>CI_PRC_INH_PL</b> tables. The valid values are:</p> <ul style="list-style-type: none"> <li>• true</li> <li>• false</li> </ul>	Yes
Maximum Price Item Parameters Cache Size	<p>Used to indicate the maximum number of price items whose parameter information can be cached in the memory.</p>	Yes
Maximum Price Item Parameter Groups Cache Size	<p>Used to indicate the maximum number of price item parameter groups whose information can be cached in the memory.</p>	Yes

Option Type	Description	Mandatory (Yes or No)
SQ Recalculation Required	<p>Used to indicate whether the SQIs in an aggregated billable charge must be recalculated while executing the <b>CI-TXNCU</b> batch. The valid values are:</p> <ul style="list-style-type: none"> <li>• Y</li> <li>• N</li> </ul> <p><b>Note:</b> If you do not specify the value for this option type or if you set the value to <b>N</b>, the system will not recalculate the SQIs in an aggregated billable charge.</p>	No
Transaction Detail Account Validation	<p>Used to indicate whether the account must be validated during the transaction validation process. The valid values are:</p> <ul style="list-style-type: none"> <li>• Y</li> <li>• N</li> </ul> <p><b>Note:</b></p> <p>If you set this option type to <b>N</b>, the system overrides the transaction's account identifier type, account identifier, and division with the first derived account's account identifier type, account identifier, and division, respectively.</p> <p>If you do not specify the value for this option type, the system will validate the account during the transaction validation process.</p>	No
Populate Summary Table Batch Description	<p>Used to specify the description for the batch which is used for adding a summary record in the <b>CI_TXN_DTL_PRITM_SUMMARY</b> table. For example, <b>Populate CI_TXN_DTL_PRITM_SUMMARY Table</b>. This description appears in the error message when the transaction aggregation batches are not executed in the specified sequence.</p>	<p>Yes (Conditional)</p> <p><b>Note:</b> This data is required when the <b>Use CI-TXNPS During Transaction Aggregation</b> option type is set to <b>true</b>.</p>
Find Price Item Pricing Batch Description	<p>Used to specify the description for the batch which is used for finding the price item pricing for transactions in the transaction aggregation cycle. For example, <b>Price Item Pricing Verification</b>. This description appears in the error message when the transaction aggregation batches are not executed in the specified sequence.</p>	Yes

Option Type	Description	Mandatory (Yes or No)
Update Transaction Status Batch Description	Used to specify the description for the batch which is used for updating the status of the transactions (for which the error has occurred) in the transaction aggregation cycle. For example, <b>Update Status</b> . This description appears in the error message when the transaction aggregation batches are not executed in the specified sequence.	Yes
Service Quantity Calculation Batch Description	Used to specify the description for the batch which is used for creating the billable charges for transactions in the transaction aggregation cycle. For example, <b>Service Quantity Calculation</b> . This description appears in the error message when the transaction aggregation batches are not executed in the specified sequence.	Yes
Transaction Completion Batch Description	Used to specify the description for the batch which is used for updating the status of the transactions in the transaction aggregation cycle. For example, <b>Mark Completion</b> . This description appears in the error message when the transaction aggregation batches are not executed in the specified sequence.	Yes
Cleanup Unwanted Data Batch Description	Used to specify the description for the batch which is used for updating or deleting billable charges created for transactions in the transaction aggregation cycle. For example, <b>Clean Up</b> . This description appears in the error message when the transaction aggregation batches are not executed in the specified sequence.	Yes

Option Type	Description	Mandatory (Yes or No)
Use C1-TXNPS During Transaction Aggregation	<p>Used to indicate whether you want to use an alternative transaction aggregation process when the aggregation ratio is low. The valid values are:</p> <ul style="list-style-type: none"> <li>• true</li> <li>• false</li> </ul> <p><b>Note:</b> If you set this option type to <b>true</b>, you need to execute the following batches in the specified order in the transaction aggregation cycle:</p> <ol style="list-style-type: none"> <li>1. Flush All Caches (F1-FLUSH)</li> <li>2. Refresh Pricing (C1-TXNRP)</li> <li>3. Header Validation (C1-TXNHV)</li> <li>4. Validate Transaction and Derive Price Item (C1-TXNIP)</li> <li>5. Populate CI_TXN_DTL_PRITM_SUMMARY Table (C1-TXNPS)</li> <li>6. Price Item Pricing Verification (C1-TXNVP)</li> <li>7. Update Status (C1-TXNEX)</li> <li>8. Service Quantity Calculation (C1-TXNSQ)</li> <li>9. Mark Completion (C1-TXNCM)</li> <li>10. Clean Up (C1-TXNCU) with the <b>Request Type</b> parameter set to <b>EROR</b></li> </ol>	No

6. Enter the values for the required option types in the **Feature Configuration** screen.
7. Click the **Save** button in the **Page Title** area.

The changes made to the feature configuration are saved.

## Setting the C1-OFFSETREQ Feature Configuration

The **C1-OFFSETREQ** feature configuration enables the system to determine whether the completed debit or credit bills of the effective child persons of the main customer (whose bill is added as the primary bill in the offset request) should be listed when you search for a bill in the offset request.

### Procedure

To set the **C1-OFFSETREQ** feature configuration:

1. Click the **Admin** link in the **Application** toolbar.  
A list appears.
2. From the **Admin** menu, select **F** and then click **Feature Configuration**.  
A sub-menu appears.
3. Click the **Search** option from the **Feature Configuration** sub-menu.  
The **Feature Configuration Search** window appears.
4. Enter **C1-OFFSETREQ** in the **Feature Name** field.
5. Click the **Search** button corresponding to the **Feature Name** field.

The **Feature Configuration** screen appears. It contains the following option types:

Option Type	Description	Mandatory (Yes or No)
Allow Offsetting Across Persons	Used to indicate whether you want to offset bills across main customer's hierarchy. The valid values are: <ul style="list-style-type: none"> <li>• <b>Y</b> - Used when you want to offset one or more bills of the main customer against one or more bills of the same or other accounts of the main customer or against one or more bills of the accounts of its effective child persons.</li> <li>• <b>N</b> - Used when you want to offset one or more bills of the main customer against one or more bills of the same or other accounts of the main customer.</li> </ul>	Yes

6. Enter the values for the required option types in the **Feature Configuration** screen.
7. Click the **Save** button in the **Page Title** area.  
The changes made to the feature configuration are saved.

#### **Related Topics**

For more information on...	See...
How to add a debit or credit bill to an offset request	<a href="#">Adding a Debit or Credit Bill to an Offset Request</a> on page 1298

## **Setting the C1-PAYPORTAL Feature Configuration**

### **Procedure**

To set the **C1-PAYPORTAL** feature configuration:

1. Click the **Admin** link in the **Application** toolbar.  
A list appears.
2. From the **Admin** menu, select **F** and then click **Feature Configuration**.  
A sub-menu appears.
3. Click the **Search** option from the **Feature Configuration** sub-menu.  
The **Feature Configuration Search** window appears.

4. Enter **C1-PAYPORTAL** in the **Feature Name** field.
5. Click the **Search** button corresponding to the **Feature Name** field.

The **Feature Configuration** screen appears. It contains the following option types:

Option Type	Description	Mandatory (Yes or No)
Allow Overpayment	Used to indicate whether you want to allow overpayment against an entity while editing the payment amount. The valid values are: <ul style="list-style-type: none"> <li>• true</li> <li>• false</li> </ul>	Yes
FK Reference for Bill	Used to indicate the foreign key reference which generates the information string for a bill in the <b>Edit Payment Amount</b> screen. <div style="border: 1px solid black; padding: 2px; margin-top: 5px;"> <p><b>Note:</b> The C1-BLACT foreign key reference for bill is shipped with the product. You can also create a custom foreign key reference, if required.</p> </div>	Yes
FK Reference for Bill Segment	Used to indicate the foreign key reference which generates the information string for a bill segment in the <b>Edit Payment Amount</b> screen. <div style="border: 1px solid black; padding: 2px; margin-top: 5px;"> <p><b>Note:</b> The C1-BSEG foreign key reference for bill segment is shipped with the product. You can also create a custom foreign key reference, if required.</p> </div>	Yes
FK Reference for Contract	Used to indicate the foreign key reference which generates the information string for a contract in the <b>Edit Payment Amount</b> screen. <div style="border: 1px solid black; padding: 2px; margin-top: 5px;"> <p><b>Note:</b> The C1_F_SA foreign key reference for contract is shipped with the product. You can also create a custom foreign key reference, if required.</p> </div>	Yes
FK Reference for Settlement	Used to indicate the foreign key reference which generates the information string for a settlement ID in the <b>Edit Payment Amount</b> screen. <div style="border: 1px solid black; padding: 2px; margin-top: 5px;"> <p><b>Note:</b> At present, no foreign key reference for settlement ID is shipped with the product. Only the settlement ID appears in the information string. You can create a foreign key reference for settlement ID and specify it in this field.</p> </div>	No

6. Enter the values for the required option types in the **Feature Configuration** screen.
7. Click the **Save** button in the **Page Title** area.

The changes made to the feature configuration are saved.

### **Related Topics**

<b>For more information on...</b>	<b>See...</b>
How to edit the payment amount against each entity	<a href="#">Editing the Payment Amount</a> on page 1200

## Setting the C1\_PERACCT Feature Configuration

### Procedure

To set the **C1\_PERACCT** feature configuration:

1. Click the **Admin** link in the **Application** toolbar.  
A list appears.
2. From the **Admin** menu, select **F** and then click **Feature Configuration**.  
A sub-menu appears.
3. Click the **Search** option from the **Feature Configuration** sub-menu.  
The **Feature Configuration Search** window appears.
4. Enter **C1\_PERACCT** in the **Feature Name** field.
5. Click the **Search** button corresponding to the **Feature Name** field.

The **Feature Configuration** screen appears. It contains the following option types:

Option Type	Description	Mandatory (Yes or No)
Create Person Account Together	Used to indicate whether you want to create a person and account for that person simultaneously. The valid values are: <ul style="list-style-type: none"> <li>• Y</li> <li>• N</li> </ul>	Yes

6. Enter the values for the required option types in the **Feature Configuration** screen.
7. Click the **Save** button in the **Page Title** area.

The changes made to the feature configuration are saved.

## Setting the C1\_PERSTYPE Feature Configuration

The **C1\_PERSTYPE** feature configuration enables the system to determine whether the entities should be created directly or through a customer registration object whenever a health care inbound message is processed. If the person type specified in the health care inbound message matches the person type specified in the **Bill Group Person Type** or **Parent Person Type** option type of the **C1\_PERSTYPE** feature configuration, the system creates or updates the person, account, policy, policy plan, and address through a customer registration object. Note that the memberships, pass-through billable charges, and pricing rules are created directly and not via customer registration object. However, if the person type specified in the health care inbound message does not match the person type specified in the **Bill Group Person Type** or **Parent Person Type** option type, the system creates or updates the person and its other entities directly and not through a customer registration object.

### Prerequisites

To set the **C1\_PERSTYPE** feature configuration, you should have:



- Values defined for the **PER\_OR\_BUS\_FLG** lookup field

### **Procedure**

To set the **C1\_PERSTYPE** feature configuration:

1. Click the **Admin** link in the **Application** toolbar.  
A list appears.
2. From the **Admin** menu, select **F** and then click **Feature Configuration**.  
A sub-menu appears.
3. Click the **Search** option from the **Feature Configuration** sub-menu.  
The **Feature Configuration Search** window appears.
4. Enter **C1\_PERSTYPE** in the **Feature Name** field.
5. Click the **Search** button corresponding to the **Feature Name** field.

The **Feature Configuration** screen appears. It contains the following option types:

Option Type	Description	Mandatory (Yes or No)
Bill Group Person Type	Used to specify the person type which indicates that the person is a bill group.  <b>Note:</b> You must specify a value which is already defined in the <b>PER_OR_BUS_FLG</b> lookup field. It must be in the <b>Active</b> status.	Yes (Conditional)  <b>Note:</b> This data is required when you want to process a health care inbound message.
Parent Person Type	Used to specify the person type which indicates that the person is a parent customer.  <b>Note:</b> You must specify a value which is already defined in the <b>PER_OR_BUS_FLG</b> lookup field. It must be in the <b>Active</b> status.	Yes (Conditional)  <b>Note:</b> This data is required when you want to process a health care inbound message.

6. Enter the values for the required option types in the **Feature Configuration** screen.
7. Click the **Save** button in the **Page Title** area.  
The changes made to the feature configuration are saved.

### **Related Topics**

For more information on...	See...
Health Care Inbound Message	<a href="#">Health Care Inbound Message</a> on page 1863

## **Setting the C1\_PER\_REL Feature Configuration**

You can define person to person relationship type sequence in the **C1\_PER\_REL** feature configuration. This sequence is used while searching for effective price item pricing at the parent customer level.

### **Procedure**

To set the **C1\_PER\_REL** feature configuration:

1. Click the **Admin** link in the **Application** toolbar.  
A list appears.

- From the **Admin** menu, select **F** and then click **Feature Configuration**.

A sub-menu appears.

- Click the **Search** option from the **Feature Configuration** sub-menu.

The **Feature Configuration Search** window appears.

- Enter **C1\_PER\_REL** in the **Feature Name** field.

- Click the **Search** button corresponding to the **Feature Name** field.

The **Feature Configuration** screen appears. It contains the following option types:

Option Type	Description	Mandatory (Yes or No)
Person to Person Relationship Type	Used to indicate the person to person relationship type.  <b>Note:</b> If you want to define more than one relationship type in the feature configuration, you need to specify the sequence in which the relationship type should be considered while searching effective price item pricing at the parent customer level.	Yes

- Enter the values for the required option types in the **Feature Configuration** screen.

- Click the **Save** button in the **Page Title** area.

The changes made to the feature configuration are saved.

### **Related Topics**

For more information on...	See...
<b>Person to Person Relationship Type Sequence</b> screen	<a href="#">Person to Person Relationship Type Sequence</a> on page 598

## **Setting the C1\_PPARM\_FLG Feature Configuration**

### **Procedure**

To set the **C1\_PPARM\_FLG** feature configuration:

- Click the **Admin** link in the **Application** toolbar.

A list appears.

- From the **Admin** menu, select **F** and then click **Feature Configuration**.

A sub-menu appears.

- Click the **Search** option from the **Feature Configuration** sub-menu.

The **Feature Configuration Search** window appears.

- Enter **C1\_PPARM\_FLG** in the **Feature Name** field.

- Click the **Search** button corresponding to the **Feature Name** field.

The **Feature Configuration** screen appears. It contains the following option types:

Option Type	Description	Mandatory (Yes or No)
Multi Price Parameter	Used to indicate whether you want to use the multi parameter based pricing feature. The valid values are: <ul style="list-style-type: none"> <li>• <b>True</b> — Indicates that you want to enable the multi parameter based pricing feature.</li> <li>• <b>False</b> — Indicates that you want to disable the multi parameter based pricing feature.</li> </ul>	Yes

6. Enter the values for the required option types in the **Feature Configuration** screen.
7. Click the **Save** button in the **Page Title** area.

The changes made to the feature configuration are saved.

### Related Topics

For more information on...	See...
<b>Multi Parameter Based Pricing</b> feature	<a href="#">Multi Parameter Based Pricing</a> on page 273

## Setting the C1\_PRASNORDR Feature Configuration

### Procedure

To set the **C1\_PRASNORDR** feature configuration:

1. Click the **Admin** link in the **Application** toolbar.  
A list appears.
2. From the **Admin** menu, select **F** and then click **Feature Configuration**.  
A sub-menu appears.
3. Click the **Search** option from the **Feature Configuration** sub-menu.  
The **Feature Configuration Search** window appears.
4. Enter **C1\_PRASNORDR** in the **Feature Name** field.
5. Click the **Search** button corresponding to the **Feature Name** field.

The **Feature Configuration** screen appears. It contains the following option types:

Option Type	Description	Mandatory (Yes or No)
Price Assignment Algorithm	Used to specify the algorithm which contains the default search order for global customers. The valid search order values are: <ul style="list-style-type: none"> <li>• AGREED_PRICELIST</li> <li>• AGREED_FIRST</li> </ul> You can change this default search order, whenever required. You can also create a custom search order, if required.	Yes

6. Enter the values for the required option types in the **Feature Configuration** screen.

- Click the **Save** button in the **Page Title** area.

The changes made to the feature configuration are saved.

#### Related Topics

For more information on...	See...
<b>Pricing (Person)</b> screen	<a href="#">Pricing (Person)</a> on page 473

## Setting the C1\_PR\_REC Feature Configuration

### Procedure

To set the **C1\_PR\_REC** feature configuration:

- Click the **Admin** link in the **Application** toolbar.  
A list appears.
- From the **Admin** menu, select **F** and then click **Feature Configuration**.  
A sub-menu appears.
- Click the **Search** option from the **Feature Configuration** sub-menu.  
The **Feature Configuration Search** window appears.
- Enter **C1\_PR\_REC** in the **Feature Name** field.
- Click the **Search** button corresponding to the **Feature Name** field.

The **Feature Configuration** screen appears. It contains the following option types:

Option Type	Description	Mandatory (Yes or No)
Effective Pricing RecordSet Limit	Used to specify the number of records that can be displayed in the <b>Search Results</b> section of the <b>Effective Price Assignment</b> zone. The value must be an integer and not in decimals. The maximum number of records that can be displayed are 5000.  <b>Note:</b> If you enter the value as <b>0</b> or if you do not specify the value for the <b>Effective Pricing RecordSet Limit</b> option type, no records will be displayed in the <b>Search Results</b> section.	Yes

- Enter the values for the required option types in the **Feature Configuration** screen.
- Click the **Save** button in the **Page Title** area.

The changes made to the feature configuration are saved.

#### Related Topics

For more information on...	See...
<b>Effective Price Assignment</b> zone in the <b>Pricing (Account)</b> screen	<a href="#">Effective Price Assignments for Account</a> on page 440
<b>Effective Price Assignment</b> zone in the <b>Pricing (Person)</b> screen	<a href="#">Effective Price Assignments for Person</a> on page 474

## Setting the C1-PYREQSRT Feature Configuration

### Procedure

To set the **C1-PYREQSRT** feature configuration:

1. Click the **Admin** link in the **Application** toolbar.  
A list appears.
2. From the **Admin** menu, select **F** and then click **Feature Configuration**.  
A sub-menu appears.
3. Click the **Search** option from the **Feature Configuration** sub-menu.  
The **Feature Configuration Search** window appears.
4. Enter **C1-PYREQSRT** in the **Feature Name** field.
5. Click the **Search** button corresponding to the **Feature Name** field.

The **Feature Configuration** screen appears. It contains the following option types:

Option Type	Description	Mandatory (Yes or No)
Bill	Used to sort columns by the selected option type. The table fields in CI_BILL table are used to set the values for the option type <b>Bill</b> . It also enables sorting by order. Its valid values are: <ul style="list-style-type: none"> <li>• Ascending</li> <li>• Descending</li> </ul>	No
Bill Segment	Used to sort columns by the selected option type. The table fields in CI_BSEG table are used to set the values for the option type <b>Bill Segment</b> . It also enables sorting by order. Its valid values are: <ul style="list-style-type: none"> <li>• Ascending</li> <li>• Descending</li> </ul>	No
Contract	Used to sort columns by the selected option type. The table fields in CI_SA table are used to set the values for the option type <b>Contract</b> . It also enables sorting by order. Its valid values are: <ul style="list-style-type: none"> <li>• Ascending</li> <li>• Descending</li> </ul>	No

**Note:** Above options types are configured for the **Sort By** field for sorting columns on the **Edit Payment Amount** screen.

6. Enter the values for the required option types in the **Feature Configuration** screen.
7. Click the **Save** button in the **Page Title** area.

The changes made to the feature configuration are saved.

## Setting the C1\_RLENG Feature Configuration

### Procedure

To set the **C1\_RLENG** feature configuration:

1. Click the **Admin** link in the **Application** toolbar.  
A list appears.
2. From the **Admin** menu, select **F** and then click **Feature Configuration**.  
A sub-menu appears.
3. Click the **Search** option from the **Feature Configuration** sub-menu.  
The **Feature Configuration Search** window appears.
4. Enter **C1\_RLENG** in the **Feature Name** field.
5. Click the **Search** button corresponding to the **Feature Name** field.

The **Feature Configuration** screen appears. It contains the following option types:

Option Type	Description	Mandatory (Yes or No)
Logging Rules for Transaction Feed	Used to indicate whether a log should be generated when you execute the <b>Transaction Validation and Initial Product Determination (C1-TXNIP)</b> batch. The valid values are: <ul style="list-style-type: none"> <li>• True</li> <li>• False</li> </ul> <div style="border: 1px solid black; padding: 5px; margin-top: 10px;"> <b>Note:</b> This log indicates the rules that were executed for each transaction and whether each rule passed or failed during the execution. </div>	Yes
Maximum Number of Rules in Cache	Used to indicate the maximum number of rules whose entry should be created in the log file.	Yes

6. Enter the values for the required option types in the **Feature Configuration** screen.
7. Click the **Save** button in the **Page Title** area.

The changes made to the feature configuration are saved.

### Related Topics

For more information on...	See...
Transaction Feed Management	<a href="#">Transaction Feed Management</a> on page 847

## Setting the C1-TXNDMYID Feature Configuration

For manually added transactions, the system can generate header details including the header ID automatically if you set the option types in the **C1-TXNDMYID** feature configuration.

### Procedure

To set the **C1-TXNDMYID** feature configuration:

1. Click the **Admin** link in the **Application** toolbar.  
A list appears.
2. From the **Admin** menu, select **F** and then click **Feature Configuration**.  
A sub-menu appears.
3. Click the **Search** option from the **Feature Configuration** sub-menu.  
The **Feature Configuration Search** window appears.
4. Enter **C1-TXNDMYID** in the **Feature Name** field.
5. Click the **Search** button corresponding to the **Feature Name** field.

The **Feature Configuration** screen appears. It contains the following option types:

Option Type	Description	Mandatory (Yes or No)
Dummy File Name	Used to specify the dummy file name.	Yes
Dummy Header ID	Used to specify the dummy header ID.	Yes
Dummy Transaction Source	Used to specify the dummy transaction source.	Yes
Dummy Header Date	Used to specify the dummy header date.	Yes

6. Enter the values for the required option types in the **Feature Configuration** screen.
7. Click the **Save** button in the **Page Title** area.

The changes made to the feature configuration are saved.

#### **Related Topics**

For more information on...	See...
Transaction Feed Management	<a href="#">Transaction Feed Management</a> on page 847

